

# **Caterpillar Performance Handbook**

**47**

**CATERPILLAR<sup>®</sup>**

# CONTENTS

	<b>Page</b>
Preface . . . . .	4
Environment and Sustainability . . .	4
Operator and Machine Protection . . . . .	5
Operator Training . . . . .	5
Machine Modifications . . . . .	7
Equipment Options . . . . .	7
Machine Protection . . . . .	7
Fire Prevention . . . . .	7
Safety Regulations . . . . .	8
Sound Suppression . . . . .	8
Replacement Parts Warning . .	8
Nomenclature . . . . .	9

<b>ARTICULATED TRUCKS</b>	<b>1</b>
<b>BACKHOE LOADERS</b>	<b>2</b>
<b>DRILLS</b>	<b>3</b>
<b>ENGINES</b>	<b>4</b>
<b>FOREST PRODUCTS</b>	<b>5</b>
<b>HIGHWALL MINING SYSTEM</b>	<b>6</b>
<b>HYDRAULIC EXCAVATORS</b> – Front Shovels • Hydraulic Excavators	<b>7</b>
<b>HYDROMECHANICAL ATTACHMENTS</b>	<b>8</b>
<b>MATERIAL HANDLERS</b>	<b>9</b>
<b>MINING &amp; OFF-HIGHWAY TRUCKS</b>	<b>10</b>
<b>MOTOR GRADERS</b>	<b>11</b>
<b>ON-HIGHWAY TRUCKS</b>	<b>12</b>
<b>PAVING PRODUCTS</b>	<b>13</b>
<b>PIPELAYERS</b>	<b>14</b>
<b>SKID STEER LOADERS • MULTI TERRAIN LOADERS</b> • COMPACT TRACK LOADERS	<b>15</b>
<b>SURFACE MINING EXTRACTION</b> – Draglines • Electric Rope Shovels • Hydraulic Mining Shovels	<b>16</b>
<b>TELESCOPIC HANDLERS</b>	<b>17</b>
<b>TRACK LOADERS</b>	<b>18</b>

# CATERPILLAR PERFORMANCE HANDBOOK

a publication by Caterpillar, Peoria, Illinois, U.S.A.

JANUARY 2017

Performance information in this booklet is intended for estimating purposes only. Because of the many variables peculiar to individual jobs (including material characteristics, operator efficiency, underfoot conditions, altitude, etc.), neither Caterpillar nor its dealers warrant that the machines described will perform as estimated.

**NOTE: Always refer to the appropriate Operation and Maintenance Manual for specific product information.**

Materials and specifications are subject to change without notice.

CAT, CATERPILLAR, SAFETY.CAT.COM, their respective logos, "Caterpillar Yellow" and the "Power Edge" trade dress, as well as corporate and product identity used herein, are trademarks of Caterpillar and may not be used without permission.

<b>TRACK-TYPE TRACTORS</b>	<b>19</b>
<b>UNDERGROUND MINING EQUIPMENT</b> – Hard Rock • Longwall • Room & Pillar	<b>20</b>
<b>WASTE HANDLING</b>	<b>21</b>
<b>WHEEL DOZERS • SOIL COMPACTORS</b>	<b>22</b>
<b>WHEEL LOADERS • INTEGRATED TOOLCARRIERS</b>	<b>23</b>
<b>WHEEL TRACTOR-SCRAPERS</b>	<b>24</b>
<b>ESTIMATING OWNING &amp; OPERATING COSTS</b>	<b>25</b>
<b>FORMER MODELS</b>	<b>26</b>
<b>LAND CLEARING</b>	<b>27</b>
<b>MINING AND EARTHMOVING</b>	<b>28</b>
<b>STOCKPILE COAL HANDLING</b>	<b>29</b>
<b>TABLES</b>	<b>30</b>
<b>TECHNOLOGY PRODUCTS</b>	<b>31</b>
<b>TIRES</b>	<b>32</b>

# PREFACE

Machine performance must ultimately be measured in unit cost of material moved, a measure that includes both production and costs. Factors bearing directly on productivity include such things as weight to horsepower ratio, capacity, type of transmission, speeds and operating costs. The Performance Handbook considers these factors in detail. There are other less direct machine performance factors for which no tables, charts or graphs are possible. Serviceability, parts availability and operator convenience are examples. In comparing machine performance, all factors should be considered. This Handbook is intended as an aid which, when coupled with experience and a good knowledge of local conditions, can assist in estimating true machine performance.

Many sections of the Handbook include tables or curves showing cycle times or hourly production figures for Cat<sup>®</sup> machines under certain conditions. Statements of conditions always accompany or precede the curves or tables. Before using any performance information in this Handbook, a complete understanding of the qualifying conditions is essential. The data is based on field testing, computer analysis, laboratory research and experience; and every effort has been made to assure their correctness.

However, all such data is based upon 100% efficiency in operation — a status which cannot be achieved continuously even under ideal conditions. Thus, in using such performance and production data, it is necessary to correct the results indicated in the handbook tables by appropriate factors. This allows for the anticipated actual job efficiency, operator efficiency, material characteristics, haul road conditions, altitude and other factors which may reduce performance or production on a particular job.

Methods for estimating machine owning and operating costs vary widely, depending on locality, industry practices, owner preferences and other factors. One method is suggested in the Handbook section on Owning and Operating Costs. When used with good judgment, it has provided reasonably accurate estimates in the past. Included in the Owning and Operating Section are guidelines, based on working conditions, to assist in estimating consumption of fuel and lubricants, tire life and repair costs for Cat machines. However, what one Handbook user regards as “excellent” conditions, another may consider “severe” or “average”, depending on his own experience and basis of comparison. Therefore, these guidelines should be considered only approximations.

Caterpillar has made every effort to assure that the information contained in this Handbook is accurate and is a fair statement of the results to be achieved in the circumstances indicated. However, because of the many variables involved in estimating the production or performance of earthmoving machinery, their consumption of fuel and lubricants, tire life and repair costs, and the possibility of inadvertent errors or omissions in assembling this data, Caterpillar cannot and does not imply that all data in this book are complete nor that this level of performance will be achieved on a given job.

Specifications shown in this Handbook were current at time of printing. However, due to Caterpillar's many machine improvement programs, specifications and materials may change without notice. For current specifications relating to a machine's performance, please refer to the most recent Cat product specification sheet.

**Caterpillar**

## ENVIRONMENT AND SUSTAINABILITY

Caterpillar supports environmental responsibility through sustainable development. Our products and services are intended to support sustainable development of global resources and they will meet or exceed applicable regulations and standards wherever they are initially sold. We establish and adhere to environmentally sound policies and practices in product design, engineering, and manufacturing. We educate and encourage

our customers to use the products they purchase from us in environmentally responsible ways. We take effective steps to continually increase the natural resources efficiency and cleanliness of our facilities. When available, the various product groups have included relevant sustainability data with their content updates for inclusion in the Performance Handbook.

# OPERATOR AND MACHINE PROTECTION

A well trained operator, working under suitable conditions, utilizing a modern, properly-equipped machine provides a machine-operator team capable of giving maximum production. These factors, along with appropriate job site rules and communication procedures, are essential to coordinate people and machines working together.

Appropriately protected and maintained machines are less likely to suffer premature component failure or damage, and give operators the confidence and assurance they need to carry out their work. Furthermore, training is not complete until the operator reads, understands and agrees to follow the instructions provided in the Operation and Maintenance Manual included with every Cat machine.

Employers have a duty to provide a safe work place for their employees. The purchaser of a Cat machine has a duty to review his/her particular application and job site for the machine to identify potential hazards inherent to that application or job site. Based on the results of this hazard analysis, the appropriate operator and machine protection configuration can be determined.

Caterpillar designs, builds, and tests its products to ensure the safety of operators, maintenance persons, service persons, and bystanders. That means people in, on and around Cat products. Caterpillar provides as standard equipment the appropriate operator and machine protection for most applications. However, particular applications, including the use of some Work Tools, may require additional operator and/or machine protection. Caterpillar offers related options for most such applications. However, there may be very special applications where the Cat dealer or the Purchaser may want to fabricate, or request Caterpillar to provide, custom or special guarding. Your Cat dealer can help you with this hazard analysis and guarding configuration process.

## I. Operator Training and Protection Practices

*Remember that any kind of machine or mechanical device can be hazardous if not kept in good condition, or if operated by careless or improperly trained operators, or if operated in an irresponsible manner.*

Listed below are some recommended basic steps that can be broadly applied to most work environments:

- Train operators for the job they are assigned to do. The length and type of training must comply with governmental and local regulations wherever they apply. As an example, machine operators in mining activities must be trained in accordance with Mine Safety and Health Administration (MSHA) regulations. Where specific regulations do not apply, no operator should be assigned to a job until he or she meets the following minimum requirements:
  - Completes proper training to operate the assigned machine and understands that seat belts must be worn whenever seated in operator's compartment. **SEAT BELTS SAVE LIVES!**
  - Reads and understands the Operation & Maintenance manual for that machine, and knows that a copy of that manual is stored in the operator's compartment.
  - Reads and understands the AEM (Association of Equipment Manufacturers) Safety Manual, or any other furnished manual related to rules for safe machine operation and identification of hazards. For example, that includes the Work Tool Operation and Maintenance Manual if a Cat Work Tool is involved in the given application.
  - Has appropriate personal protective equipment and knows how to use it. This includes such things as hard hat, gloves, safety glasses, hearing protection, high-visibility vest, and safety shoes.
  - Knows what the job requirements are, what other machines are working in the area, and is aware of any hazardous conditions that may arise.

- Be sure operators are alert and in proper physical and mental condition to perform their work assignments safely. No machine should be operated by a person who is drowsy, under the affect of medicines or drugs, suffers blackouts, or is suffering from any physical or mental distraction that could contribute to unsafe operation.
- Maintain proper job conditions and working procedures. Check the job for possible hazards, both above and below ground level. Look for all possible sources of danger to the operator and others in the area. When operating in hazardous conditions the door and windows must always be closed. Pay particular attention to conditions which may be hazardous or near the operating limits of the machine: e.g., side slopes, steep grades, potential overloads, etc. Examine the work site for restricted traffic patterns, obstructed views, congestion, underground power or gas lines, etc. If the machine is equipped with a Quick Coupler, always make sure the Work Tool is properly attached by conducting an attachment test as directed in the Quick Coupler or Machine Operation and Maintenance Manual. Hazardous work conditions should be corrected wherever possible and adequate warnings should be posted when applicable.
- Provide the correct machine to handle the job and equip it properly for the job to provide the necessary operator protection. Check for compliance with all applicable governmental and local regulations. It is the legal responsibility of the machine owner or employer to see that his equipment complies with, and is operated in accordance with, all such requirements.
- Make sure the machine is properly maintained. The operator at the beginning of each shift should perform a walk-around inspection before the machine is placed in operation. This process is described in the machine and Work Tool Operation and Maintenance Manual. If this inspection reveals any problems that could affect safety, the machine or Work Tool must not be operated until these problems are corrected. Some examples include:
  - Loose, bent or missing grab irons, railings or steps;
  - Worn, cut or missing seat belts (any seat belt over three (3) years old must be replaced regardless of condition);
  - Damaged windows in the operator's compartment;
  - Worn, rubbing or abraded electrical insulation and hydraulic hoses;
  - Material or unwanted debris accumulation;
  - Incompatibility of the component attachments (Quick Couplers);
  - Hydraulic leaks that could impair the lock/secure feature of a Quick Coupler or other securing devices;
  - Any fluid leaks; and
  - Missing or damaged guards.
- Know the limits of your machine and equipment. With certain Work Tool combinations, including Quick Couplers, the Work Tool can hit the cab or the machine. Always check for interference limits when first operating.
- It is the machine owner's or employer's responsibility to ensure the machine is properly maintained. Your Cat dealer will be glad to assist you in selecting and equipping the machine best suited for your job and in providing maintenance for your machines.

## II. Machine Modifications

Modifications must not be made to the machine that:

- Interfere with operator visibility;
- Interfere with ingress or egress from the machine;
- Exceed the rated payload or gross combination weight of the machine resulting in overloading the braking and/or steering system or the roll-over protective structure (ROPS) capacity rating (shown on a plate affixed to the ROPS); or
- Place objects in the cab that intrude into the operator's space or that are not firmly fixed into place.
- Are not authorized by Caterpillar.

## III. Operator-related Equipment Options

Each job presents unique conditions that must be taken into account. Consider direct dangers to the operator as well as all possible sources of distraction that could reduce operator efficiency and increase the chances of costly and dangerous mistakes. Climate-controlled, sound-suppressed cabs, and special exterior lighting are options available from Caterpillar that can address requirements of special working environments.

“Flexible” machines include hydraulic excavators (track-type, wheel-type, and compact), skid-steer loaders, backhoe loaders and integrated tool-carriers can utilize interchangeable “Work Tools” to accomplish specific tasks. Work Tools or any tool used in hazardous applications like demolition, quarry, logging, stump grinding, scrap handling, milling, and scaling, can create a need for special operator guarding. When flying debris from impact, cutting, shearing or sweeping attachments is present, additional protective devices such as a front screen, Falling Object Guarding System (FOGS, includes top & front guarding), thick polycarbonate windshields or a combination of these is recommended by Caterpillar. The failure to provide proper operator/machine guarding in some of these applications can lead to machine damage, personal injury or death. Contact your Cat dealer for operator guarding options on your machine.

## IV. Machine Protection

Check the job for unusually demanding conditions that could cause premature failure or excessive wear of machine components. Additional protective devices such as heavy-duty radiator guards, crankcase guards, engine enclosures, track roller guards and/or brake shields may be needed. Also, consider the use of anti-vandalism devices, such as cap locks and instrument panel guards. The failure to provide proper guarding in some of these applications may lead to machine damage, personal injury or death. Contact your Cat dealer for machine-protection and vandalism-prevention options for your machine.

## V. Fire Prevention

*Remember that most fluids on your machine are flammable!*

To minimize the risk of fire, Caterpillar recommends following these basic steps:

- Always perform the Walk-Around Inspection described in Part I. It can identify many of the fire hazards described below.
- Remove trash (leaves, twigs, papers, etc.) that may accumulate in the engine compartment or around other hot parts on the product.
- Do not operate a machine if leakage of flammable fluids is noticed. Repair leaks before resuming machine operation. Most fluids used in Cat machines should be considered flammable.
- Keep access doors to major machine compartments in working order to permit the use of fire fighting equipment, should a fire occur.
- Avoid attaching electrical wiring to hoses and tubes that contain flammable or combustible fluids. Hydraulic hoses can move during machine operation and abrade wires and other hoses if improperly secured.
- Replace any rubbing, damaged, frayed, kinked or leaking hydraulic hoses or fittings. Use genuine Cat parts or their equivalent, including both pressure and temperature limit capabilities.
- Follow safe fueling practices as described in Cat Operation and Maintenance Manuals, AEM Safety Manuals, and local regulations. Never store flammable fluids in the machine operator's compartment, nor smoke while fueling the machine.
- As an additional safety measure, keep a fire extinguisher on the machine in a location as specified in the Operation and Maintenance Manual.
- Consider installation of an after-market fire-suppression system (FSS) on the equipment if the application and working conditions warrant it.



## VI. Safety Regulations

Regulations vary from country to country and often within country. Your Cat dealer can assist you in properly equipping your machine to meet applicable requirements. **Note: The general summaries given below are not substitutes for Owners or Employers reading and being familiar with the appropriate local laws.**

### (a) United States (US)

With a few exceptions, all machine operations in the United States are covered by federal and/or state regulations. If the machine is used in mining activities, the regulations are administered by the Mine Safety and Health Administration (MSHA). Other activities, including construction, are under regulations administered by the Occupational Safety and Health Administration (OSHA). These agencies require employers to provide a safe working environment for employees. Caterpillar has the same objective.

OSHA and MSHA have adopted criteria for ROPS, Falling Object Protective Structures (FOPS), seat belts, warning horns, back-up alarms, operator sound levels, steering systems, and braking systems. Additional operator's compartment protection may be required for machines engaged in logging, demolition and other special applications.

### (b) European Union (EU)

The EU Machinery Safety Directive applies to Cat machines and most work tools. It requires that the "CE mark" be applied to the product and that a manufacturer's declaration be provided. The "CE mark" indicates that safety issues have been addressed by applying the appropriate safety standards in the design and manufacture of the machine. The objective of the Safety Directive is to protect operators, spectators and maintenance personnel. Caterpillar fully supports this objective.

## VII. Sound Suppression

Different marketing areas have different noise emission requirements. Noise regulations usually specify limits for operators and spectators.

### (a) United States

OSHA and MSHA noise-control regulations set permissible noise-exposure limits for machine operators and employees. Operator protection from machine noise can be achieved by use of factory-built cabs as offered in the Caterpillar Price List. These cabs, when properly maintained and operated with the doors and windows closed, reduce the operator sound level for an eight-hour operating period to meet the OSHA and MSHA noise-exposure limits in effect at the date of manufacture. Variables that may be encountered on the job site, such as other nearby noise sources or noise-reflecting surfaces, may reduce the allowable work hours. If this occurs, hearing protection may be required. This is especially true if a machine is not equipped with a closed cab. For example if the machine has no cab, or is being operated with the doors or windows opened.

### (b) European Union

Operator sound-exposure requirements for machines in Europe are very similar to the OSHA and MSHA regulations mentioned above. In addition to operator sound-exposure requirements, most types of Cat machines are subject to European Commission regulations for exterior sound levels. Caterpillar ensures its products sold in the EU comply with the applicable noise regulations.

## VIII. Replacement Parts for your Cat Machine

### **WARNING**

When replacement parts are required for this product, Caterpillar recommends using Cat replacement parts or parts with equivalent specifications including, but not limited to, physical dimensions, type, strength and material. Failure to heed this warning can lead to premature failures, product damage, personal injury or death of persons on, or around, the product.

# Nomenclature

## THE CAT PRODUCT LINE

### ARTICULATED TRUCKS

Capacity 23.6 to 39.5 metric tons (26 to 43.5 U.S. tons)

\*OEM Solutions Group non-dumper/bare chassis for specialty applications available

725C2\*  
730C2\*

730C2 EJ  
735C\*

740C EJ  
745C\*

### BACKHOE LOADERS

Digging depth 4348 to 6501 mm (14'3" to 21'4")

415F2  
416F2  
420F2/420F2 IT  
422F2

427F2  
428F2  
430F2/430F2 IT  
432F2

434F2  
444F2  
450F

### DRILLS

#### Rotary Drills

MD6290

MD6420C

MD6540C

MD6640

#### Track Drills

MD5075C

MD5150C

### FOREST PRODUCTS

#### Track Harvesters

501HD 541 Series 2  
521B 552 Series 2  
522B

#### Track Feller Bunchers

521B 541 Series 2  
522B 552 Series 2

#### Wheel Feller Bunchers

563D  
573D

#### Felling Heads

HF201B HFW232  
HF221 HFW221  
HFW222SC

#### SATCO Directional Felling Heads

SAT420 SAT630

#### Harvester Heads

HH44 DE

#### SATCO Processor Heads

SAT214 SAT322T SAT323  
SAT318 SAT322T SC SAT323T  
SAT318T SAT422 DB SAT323T SC  
SAT318T SC SAT223 SAT325  
SAT322 SAT223T SAT325T

#### Wheel Skidders

525D 545D  
535D 555D

#### Track Skidders

527 Cable  
527 Grapple

#### Forwarders

564  
574  
584/584HD

#### Forest Machines

320D2 FM 558 LL  
538 568  
538 LL 568 LL  
324D FM

#### Knuckleboom Loaders

529 519 SM  
559C 519 SM/EHC  
579C 569 SM  
569 SM/EHC

#### Wheel Loaders

924K	950H	966H	986H
926M	950K	966K	988K
930K	950M	966M	990K
930M	962H	980H	
938K	962K	980K	
938M	962M	980M	

#### Site Prep

586C

#### Work Tools

Grapples  
Logging Forks  
Couplers  
Buckets and Thumbs  
Woodchip Dozers and Scoops  
Rakes

---

# HIGHWALL MINING SYSTEM

HW300

---

## HYDRAULIC EXCAVATORS

### Front Shovels

Operating Weight 90 080 to 91 700 kg (198,592 to 202,164 lb)

385C FS

### Hydraulic Excavators

Operating Weight 1650 to 90 390 kg (3640 to 199,220 lb)

#### Track Models

##### MINI EXCAVATORS

300.9D  
301.4C  
301.7D  
301.7D CR  
302.2D  
302.4D  
302.7D CR  
303E CR  
303.5E CR  
303.5E2 CR  
304.5E2 XTC  
305E2 CR  
305.5E2 CR  
307E2  
308E2 CR SB  
308E2 VAB

##### SMALL EXCAVATORS

311F L  
312E  
312F GC  
313D2  
313D2 GC  
313D2 L  
313D2 (LGP)  
313F  
313F L  
313F L GC  
314E  
314E L  
315F L  
316E L  
316F L  
318D2 L  
318F L

##### MEDIUM EXCAVATORS

320D2 325F L  
320D2 GC 326D2 L  
320D2 L 326F L  
320E 326F LN  
320E L 330D2 L  
320E LRR 330F L  
320E RR 330F LN  
320F L 335F L  
323D2 L  
323F L  
323F LN

##### LARGE EXCAVATORS

336D2 349D2  
336D2 GC 349D2 L  
336D2 L 349F  
336D2 XE 349F L  
336D2 L XE 349F L XE  
336F 352F  
336F L 352F XE  
336F LN 374F L  
336F XE 390F L  
336F L XE  
336F LN XE  
340D2 L

#### Wheel Models

M315D2  
M314F

M317D2  
M315F

M320D2  
M316F

M322D2  
M317F

M318F

M320F

M322F

---

## HYDROMECHANICAL ATTACHMENTS

### Hydraulic Hammers

H25D H110E s  
H35E/E s H115E s  
H45E/E s H120E s  
H55E/E s H130E s  
H65E/E s H140E s  
H75E s H160E s  
H95E s H180E s

### Mobile Scrap and Demolition Shears

S305 S340B  
S320B S365C  
S325B S385C

### Multi-Processors

MP15 MP318  
MP20 MP324  
MP30  
MP40

### Contractor's Grapples

G107B G130B  
G112B G145B  
G115B G165B  
G120B G185B  
G125B

### Demolition and Sorting Grapples

G305 G315B  
G330 G320B  
G310B G325B

### Orange Peel Grapples

GSH15B  
GSH20B  
GSH22B

---

## MATERIAL HANDLERS

### Wheel Material Handlers

M322D2 MH    M325D MH    MH3022    MH3037    MH3059  
M324D2 MH    M325D LMH    MH3024    MH3049

### Track Material Handlers

385C MH

## MINING & OFF-HIGHWAY TRUCKS

Payload capacity 36 to 363 metric tonnes (40 to 400 tons)

\*OEM Solutions Group non-dumper for special applications available

770G\*                      773G\*                      777G\*                      789D                      793F                      795F AC  
772G\*                      775G\*                      785C                      793D XLWS                      794 AC                      797F  
773E                      777E                      785D\*

## MOTOR GRADERS

Flywheel power 93 to 397 kW (125 to 533 hp)

\*All Wheel Drive.

120K	12M2	140M2	160M2
120K2	12M2 with AWD* option	140M2 with AWD* option	160M2 with AWD* option
120M	12M3	140M3	160M3
120M with AWD* option	12M3 with AWD* option	140M3 with AWD* option	160M3 with AWD* option
120M2	140K	160K	14M3 Global
120M2 with AWD* option	140K2	160M	16M3 Global
12K	140M	160M with AWD* option	18M3 Global
12M	140M with AWD* option		24M Global

## ON-HIGHWAY TRUCKS

Model	Front Axle	Chassis	BBC	BA
CT660S	SBA	6x4	116"	54"
CT660S	SBA	8x6	116"	54"
CT660L	SBA	6x4	122"	54"
CT660L	SBA	4x4	122"	54"
CT660L	SBA	6x6	122"	54"
CT660L	SBA	8x6	122"	54"
CT680	SFA	6x4	124"	30"
CT680	SFA	8x6	124"	30"
CT681	SFA	6x4	114"	28"

SBA = Set Back Axle  
SFA = Set Forward Axle  
BBC = Bumper to Back of Cab (inches)  
BA = Bumper to Front Axle  
L = Long Hood  
S = Short Hood

### Chassis A x B

A = Total Wheel Ends  
B = Powered Wheel Ends

## PAVING PRODUCTS

### Cold Planers

PM102                      PM620                      PM622

### Asphalt Pavers

AP300F                      AP1000F                      AP555F  
AP500F                      AP255E                      AP655F  
AP600F                      AP355F                      AP1055F

### Reclaimer/Soil Stabilizers

Cutting width 2438 mm (8'0")

RM300                      RM500B

### Pneumatic Tire Asphalt Compactors

CW14                      CW16                      CW34                      PS360C

### Vibratory Compactors

#### Single Drum Smooth

Drum width 1270 to 2130 mm  
(4'2" to 7'0")

#### Single Drum, Padded

Drum width 1270 to 2130 mm  
(4'2" to 7'0")

#### Double Drum and Combi

Drum width 1000 to 2130 mm  
(3'3.4" to 7'0")

CS34	CS56B	CS76B	CP34	CP56B	CB14B	CB32B	CB54B
CS423E	CS64B	CS78B	CP44B	CP68B	CB14B XW	CB34B	CD54D
CS44B	CS66B	CS79B	CP533E	CP74B	CB22B	CB36B	CB64B
CS533E	CS68B		CP54B		CB24B	CC34B	CB66B
CS54B	CS74B				CB24B XT	CB44B	CB68B
					CC24B	CB46B	

---

## PIPELAYERS

Lifting capacity 18 145 to 91 625 kg (40,000 to 202,000 lb)

PL61

PL72

PL83

PL87

---

## SKID STEER LOADERS/MULTI TERRAIN LOADERS/COMPACT TRACK LOADERS

Operating Weight 2581 to 5265 kg (5690 to 11,608 lb)

### Skid Steer Loaders

216B3 242D  
226B3 246D  
226D 262D  
232D 272D2  
236D 272D2 XHP

### Multi Terrain Loaders

257D  
277D  
287D  
297D2  
297D2 XHP

### Compact Track Loaders

239D  
249D  
259D  
279D  
289D  
299D2  
299D2 XHP

### Work Tools

#### Augers

A7B  
A14B  
A19B  
A26B

#### Backhoes

BH150  
BH160

#### Brooms

BA18  
BP15B  
BP18B  
BU115  
BU118

#### Brushcutters

BR160  
BR166  
BR172  
BR272  
BR378

#### Cold Planers

PC104B  
PC205B  
PC305B  
PC306B  
PC408B  
PC410B

#### Vibratory

Compactors  
CV16B  
CV18B

#### Mulchers

HM315B  
HM415B

#### Landscape Rakes

LR15B  
LR18B

#### Power Box Rakes

PR172  
PR184  
PR190

#### Wheel Saws

SW345B  
SW360B  
SW380B  
SW460B  
SW480B

#### Snow Blowers

SR117  
SR118  
SR121  
SR318  
SR321

#### Stump Grinder

SG16B  
SG18B

#### Landscape Tillers

LT13B  
LT18B

#### Trenchers

T6B  
T9B  
T15B

---

## SURFACE MINING EXTRACTION

### Draglines

8000  
8200  
8750 — 22.9 m (75'0") Base  
8750 — 25.6 m (84'0") Base

### Electric Rope Shovels

7295 7495 HydraCrowd™  
7395 7495 HF Rope Crowd  
7495 HD 7495 HF HydraCrowd  
7495 Rope Crowd

### Hydraulic Mining Shovels

Operating Weight 140 000 to 980 000 kg (308,650 to 2,610,510 lb)

### Backhoe Configurations

6015B  
6020B  
6030  
6040  
6050  
6060

### Backhoe Configurations with Electric Drive

6030 AC  
6040 AC  
6050 AC  
6060 AC

### Front Shovel Configurations

6030 FS 6050 FS 6090 FS  
6040 FS 6060 FS

### Front Shovel Configurations with Electric Drive

6030 AC FS 6050 AC FS 6090 AC FS  
6040 AC FS 6060 AC FS

---

## TELESCOPIC HANDLERS

### Non-U.S. Versions

TH255C	TH407C	TL642C
TH336C	TH414C	TL943C
TH337C	TH417C	TL1055C
TH406C	TH514C	TL1255C

### U.S. Versions

TH255C	TL642C
TH406C	TL943C
TH407C	TL1055C
TH514C	TL1255C

## TRACK LOADERS

Bucket Capacity (Heaped)\* 1.15 to 3.2 m<sup>3</sup> (1.5 to 4.2 yd<sup>3</sup>)

\*General Purpose Bucket.  
†Waste handling arrangement available.

953D†	953K†	963D†	963K†	973D†
-------	-------	-------	-------	-------

## TRACK-TYPE TRACTORS

Flywheel power 55 to 634 kW (74 to 850 hp)

### \*Waste Handling Arrangements (WHA)

D3K XL	D5K XL	D6K2 XL	D6T*	D7R*	D9R
D3K LGP	D5K LGP	D6K2 LGP	D6T XL*	D7R XR*	D9T*
D3K2 XL	D5K2 XL	D6N XL*	D6T XW*	D7R LGP*	D10T2
D3K2 LGP	D5K2 LGP	D6N LGP*	D6T LGP*	D8R*	D11T
D4K XL	D5R2 XL*	D6R2	D7E*	D8R LGP*	D11T CD
D4K LGP	D5R2 LGP*	D6R2 XL*	D7E LGP*	D8T*	
D4K2 XL	D5T XL*	D6R2 LGP*		D8T LGP*	
D4K2 LGP	D5T LGP*				

## UNDERGROUND MINING EQUIPMENT

### Hard Rock

#### Load-Haul-Dump

Bucket sizes 2.4-11.6 m<sup>3</sup> (3.1-15.2 yd<sup>3</sup>)

R1300G	R2900G
R1600H	R3000H
R1700G	

#### Articulated Trucks

30-60 t (33-66T) capacity

AD30	AD55 Flat Haul
AD45B	AD60

#### Hard Rock Cutting/Conveying

##### Rock Flow System

RF300	RM900
-------	-------

##### Rock Straight System

HRM220	HRC30	HRS1220
--------	-------	---------

### Longwall

#### Roof Supports

#### AFC Systems

##### AFC Line Pans

PF3	PF6
PF4	PF7
PF5	

#### Beam Stage Loaders

##### BSL Line Pans

PF4	PF6
PF5	

##### BSL Crushers

SK0909	SK1218
SK1111	SK1422
SK1118	

##### BSL Drive Frames

SPR3	SPR5
------	------

##### BSL Gearboxes

K10	KP-25/30
-----	----------

##### Boot End

SMB	CMB
-----	-----

#### CST Drive Systems

CST30	CST45 M
CST45	CST65
CST45 V	CST115

#### Automated Plow Systems

RHH800
GH800
GH800B
GH1600

#### Shearers

EL2000	EL4000
EL3000	

#### Programmable

Mining Controls	
PMC-R	PMC-D
PMC-V	MCU2

#### Variable Frequency Drives

VFD-A800/W800
VFD-A1200/W1200

#### Roof Support Carriers

SH640
SH640B
SH660
SH660B
SH620
SH630
SH650
SH680

#### Shield Trailer

SH150
-------

### Room & Pillar

#### Continuous Miners

CM210	CM340
CM220	CM345N
CM230	CM445
CM240	

#### Scoops

SU488 L
SU488
SU488 D (non XP)

#### Load Haul Dumps

CL210
CL210B
CL215

#### Face Haulage

FH120
-------

#### Continuous Haulage

FH330
-------

#### Roof Bolter

RB220
-------

#### Feeder Breaker

FB110
-------

---

## WHEEL DOZERS

Flywheel power 173 to 597 kW (232 to 801 hp)

814F2                      824K                      834K                      844K                      854K

## LANDFILL COMPACTORS

Flywheel power 173 to 349 kW (232 to 468 hp)

816F2                      826K                      836K

## SOIL COMPACTORS

Flywheel power 185 to 264 kW (248 to 354 hp)

815K                      825K

---

## WHEEL LOADERS & INTEGRATED TOOLCARRIERS

Bucket Capacity (Heaped) 0.6 to 30 m<sup>3</sup> (0.78 to 40 yd<sup>3</sup>)

\* High lift arrangement available.

† Waste handling arrangement available.

903C2	924K	950 GC	966M XE	986H*
906K	926M*†	950H*†	972H*†	988K*
906M	930K*	950K*†	972K*†	990K*
907K	930M*†	950L*†	972M*†	992K*
907M	938K*	950M*†	972L*†	993K*
908K	938M*†	962H*†	972M XE	994K*
908M		IT62H†	980H*†	
910K*		962K*†	980K*†	
910M*		962L*†	980L*†	
914K*		962M*†	980M*†	
914M*		966H*†	982M	
918M		966K*†		
		966L*†		
		966M*†		

---

## WHEEL TRACTOR-SCRAPERS

### Standard Models

Heaped capacity 18 to 26 m<sup>3</sup> (24 to 34 yd<sup>3</sup>)

621K                      631K

### Tandem Powered Scrapers

Heaped capacity 18 to 33.6 m<sup>3</sup> (24 to 44 yd<sup>3</sup>)

627K                      637K                      657G

### Elevating Scrapers

Heaped capacity 17.6 m<sup>3</sup> (23 yd<sup>3</sup>)

623K

### Coal Bowl Scrapers

Heaped capacity 38 to 56 m<sup>3</sup> (50 to 73 yd<sup>3</sup>)

637K                      657G

### Push-Pull Scrapers

Heaped capacity 18 to 33.6 m<sup>3</sup> (24 to 44 yd<sup>3</sup>)

627K                      637K                      657G

---

# ARTICULATED TRUCKS

## CONTENTS

Features . . . . .	1-1
Specifications . . . . .	1-2
Ground Pressure . . . . .	1-6
Curves:	
725C2 Rimpull-Speed-Gradeability, Brake/Retarder Performance Curve . . . . .	1-9
730C2 Rimpull-Speed-Gradeability, Brake/Retarder Performance Curve . . . . .	1-13
730C2 EJ Rimpull-Speed-Gradeability, Brake/Retarder Performance Curve . . . . .	1-17
735C Series Rimpull-Speed-Gradeability, Brake/Retarder Performance Curve . . . . .	1-21
740C EJ Series Rimpull-Speed-Gradeability, Brake/Retarder Performance Curve . . . . .	1-25
745C Series Rimpull-Speed-Gradeability, Brake/Retarder Performance Curve . . . . .	1-29

### Features:

- **Cat® engines with ACERT™ Technology** meet U.S. EPA Tier 4 Final/EU Stage IV/Japan 2014 (Tier 4 Final), or Tier 2/Stage II/Japan 2001 (Tier 2) equivalent emission standards. The four core elements of meeting these standards are:
  - I) Common Rail;
  - II) Electronics, ADEM™ A4;
  - III) Fuel delivery, Mechanical-activated Electronic Unit Injection (MEUI™ A-C);
  - IV) Air Management, Wastegate Turbocharging, Air to Air Aftercooling (ATAAC) with the proven technology of a crossflow cylinder head.
- **Cat electronically controlled transmissions** ... Transmissions purpose built and designed for articulated trucks and their applications. Advanced Productivity Electronic Control Strategy (APECS) delivering smooth shifting transmissions with improved acceleration and high productivity. Providing complete integration with the engines for efficient power delivery as well as offering advanced diagnostic and troubleshooting capabilities.

- **Articulating and fully oscillating hitch** ... Links front and rear frames for exceptional maneuverability and traction on uneven terrain while eliminating damaging twisting of the frames. Bolted hitch design allows optimum material choices for the cast hitch head and the hard-wearing tube. Bolted design allows easier rebuild and repair.
- **Three-point front suspension** ... Three-point front suspension with long-stroke, low-pressure suspension cylinders provide unparalleled ride quality for operator comfort and higher average haul speeds. Front and rear suspension together with the hitch provide for excellent traction in all conditions.
- **Wide, long and low dump body design** ... For excellent loadability and high fill factors, excellent machine stability and load retention as well as a good match for other Cat loading systems. Diverging flow design also gives excellent material ejection.
- **Standard ROPS/FOPS, low sound level cab** ... Two man cab common across the range. Large cab with excellent visibility, ergonomic control layout and plentiful storage.
- **High capacity low pressure tires in single formation** ... For superior traction and flotation in poor underfoot conditions.
- **Bare Chassis offerings** ... For certain applications the Caterpillar OEM Solutions Group offers non-dumper/Bare Chassis arrangements.
 

Bare Chassis arrangements applications could include: water, service (fuel and lube), high capacity body (waste, coal, etc.), open body (log, pipe, etc.), container carrier, hook lift, tow, cable reel, etc. Please refer to specific OEM for additional information.



<b>MODEL</b>	<b>725C2</b>		<b>730C2</b>		<b>730C2 EJ</b>	
Gross Power — SAE J1995	239 kW	<b>320 hp</b>	280 kW	<b>375 hp</b>	280 kW	<b>375 hp</b>
Net Power — SAE J1349	234 kW	<b>314 hp</b>	274 kW	<b>367 hp</b>	274 kW	<b>367 hp</b>
Net Power — ISO 14396	236 kW	<b>316 hp</b>	276 kW	<b>370 hp</b>	276 kW	<b>370 hp</b>
Operating Weight (Empty)*	23 040 kg	<b>50,795 lb</b>	23 725 kg	<b>52,305 lb</b>	26 395 kg	<b>57,277 lb</b>
Top Speed (Loaded)	55 km/h	<b>34 mph</b>	55 km/h	<b>34 mph</b>	55 km/h	<b>34 mph</b>
Gross Machine Weight	47 040 kg	<b>103,707 lb</b>	51 725 kg	<b>114,034 lb</b>	54 515 kg	<b>119,270 lb</b>
Distribution Empty:						
Front		<b>63%</b>		<b>62%</b>		<b>59%</b>
Center		<b>19%</b>		<b>19%</b>		<b>21%</b>
Rear		<b>18%</b>		<b>19%</b>		<b>20%</b>
Distribution Loaded:						
Front		<b>36%</b>		<b>34%</b>		<b>30%</b>
Center		<b>32%</b>		<b>33%</b>		<b>35%</b>
Rear		<b>32%</b>		<b>33%</b>		<b>35%</b>
Max. Capacity**	24.0 t	<b>26.5 T</b>	28 t	<b>31 T</b>	28 t	<b>31 T</b>
Struck (SAE)	11 m <sup>3</sup>	<b>14.4 yd<sup>3</sup></b>	13.3 m <sup>3</sup>	<b>17.4 yd<sup>3</sup></b>	13.5 m <sup>3</sup>	<b>17.7 yd<sup>3</sup></b>
Heaped (2:1) (SAE)	15 m <sup>3</sup>	<b>19.6 yd<sup>3</sup></b>	17.5 m <sup>3</sup>	<b>23 yd<sup>3</sup></b>	16.9 m <sup>3</sup>	<b>22.1 yd<sup>3</sup></b>
Tailgate Heaped SAE 2:1	15.6 m <sup>3</sup>	<b>20.4 yd<sup>3</sup></b>	18.8 m <sup>3</sup>	<b>24.6 yd<sup>3</sup></b>	—	—
Tailgate Struck	11.1 m <sup>3</sup>	<b>14.5 yd<sup>3</sup></b>	13.9 m <sup>3</sup>	<b>18.2 yd<sup>3</sup></b>	—	—
Engine Model	<b>C9.3 ACERT</b>		<b>C13 ACERT</b>		<b>C13 ACERT</b>	
No. Cylinders	<b>6</b>		<b>6</b>		<b>6</b>	
Bore	115 mm	<b>4.53"</b>	130 mm	<b>5.12"</b>	130 mm	<b>5.12"</b>
Stroke	149 mm	<b>5.87"</b>	157 mm	<b>6.18"</b>	157 mm	<b>6.18"</b>
Displacement	9.3 L	<b>567 in<sup>3</sup></b>	12.5 L	<b>763 in<sup>3</sup></b>	12.5 L	<b>763 in<sup>3</sup></b>
Tires	<b>23.5R25</b>		<b>23.5R25</b>		<b>750/65/R26</b>	
Clearance Radius	8075 mm	<b>317.9"</b>	8075 mm	<b>317.9"</b>	8075 mm	<b>317.9"</b>
Fuel Tank Refill Capacity	412 L	<b>108.8 U.S. gal</b>	412 L	<b>108.8 U.S. gal</b>	412 L	<b>108.8 U.S. gal</b>
DEF Tank Capacity	20 L	<b>5.3 U.S. gal</b>	20 L	<b>5.3 U.S. gal</b>	20 L	<b>5.3 U.S. gal</b>
<b>General Dimensions (Empty):</b>						
Height to Cab Top	3482 mm	<b>137.1"</b>	3482 mm	<b>137.1"</b>	3461 mm	<b>136"</b>
Overall Length	10 547 mm	<b>415.2"</b>	10 555 mm	<b>415.6"</b>	10 376 mm	<b>408.5"</b>
Loading Height (Empty)	2725 mm	<b>107.3"</b>	2911 mm	<b>114.6"</b>	3025 mm	<b>119.1"</b>
Height at Full Dump	6306 mm	<b>248.3"</b>	6464 mm	<b>254.5"</b>	—	—
Body Length	5696 mm	<b>224.3"</b>	5783 mm	<b>227.7"</b>	5340 mm	<b>210.2"</b>
Width (Operating — Over Mirrors)	3704 mm	<b>145.8"</b>	3704 mm	<b>145.8"</b>	3704 mm	<b>145.8"</b>

\*Includes coolant, lubricant and full fuel tank.

\*\*Rating dependent on optional equipment. Maximum gross weight (empty weight plus payload) should not be exceeded.

MODEL	725C2		730C2		730C2 EJ	
Gross Power — SAE J1995	239 kW	<b>320 hp</b>	280 kW	<b>375 hp</b>	280 kW	<b>375 hp</b>
Net Power — SAE J1349	234 kW	<b>314 hp</b>	274 kW	<b>367 hp</b>	274 kW	<b>367 hp</b>
Net Power — ISO 14396	236 kW	<b>316 hp</b>	276 kW	<b>370 hp</b>	276 kW	<b>370 hp</b>
Operating Weight (Empty)*	22 775 kg	<b>50,211 lb</b>	23 305 kg	<b>51,378 lb</b>	25 980 kg	<b>57,277 lb</b>
Top Speed (Loaded)	55 km/h	<b>34 mph</b>	55 km/h	<b>34 mph</b>	55 km/h	<b>34 mph</b>
Gross Machine Weight	46 775 kg	<b>103,121 lb</b>	51 305 kg	<b>113,107 lb</b>	54 100 kg	<b>119,270 lb</b>
Distribution Empty:						
Front		<b>62%</b>		<b>62%</b>		<b>58%</b>
Center		<b>19%</b>		<b>19%</b>		<b>21%</b>
Rear		<b>19%</b>		<b>19%</b>		<b>21%</b>
Distribution Loaded:						
Front		<b>35%</b>		<b>34%</b>		<b>29%</b>
Center		<b>33%</b>		<b>33%</b>		<b>36%</b>
Rear		<b>32%</b>		<b>33%</b>		<b>35%</b>
Max. Capacity**	24.0 t	<b>26.5 T</b>	28 t	<b>31 T</b>	28 t	<b>31 T</b>
Struck (SAE)	11 m <sup>3</sup>	<b>14.4 yd<sup>3</sup></b>	13.3 m <sup>3</sup>	<b>17.4 yd<sup>3</sup></b>	13.5 m <sup>3</sup>	<b>17.7 yd<sup>3</sup></b>
Heaped (2:1) (SAE)	15 m <sup>3</sup>	<b>19.6 yd<sup>3</sup></b>	17.5 m <sup>3</sup>	<b>23 yd<sup>3</sup></b>	16.9 m <sup>3</sup>	<b>22.1 yd<sup>3</sup></b>
Tailgate Heaped SAE 2:1	15.6 m <sup>3</sup>	<b>20.4 yd<sup>3</sup></b>	18.8 m <sup>3</sup>	<b>24.6 yd<sup>3</sup></b>	—	—
Tailgate Struck	11.1 m <sup>3</sup>	<b>14.5 yd<sup>3</sup></b>	13.9 m <sup>3</sup>	<b>18.2 yd<sup>3</sup></b>	—	—
Engine Model	<b>C9.3 ACERT</b>		<b>C13 ACERT</b>		<b>C13 ACERT</b>	
No. Cylinders	<b>6</b>		<b>6</b>		<b>6</b>	
Bore	115 mm	<b>4.53"</b>	130 mm	<b>5.12"</b>	130 mm	<b>5.12"</b>
Stroke	149 mm	<b>5.87"</b>	157 mm	<b>6.18"</b>	157 mm	<b>6.18"</b>
Displacement	9.3 L	<b>567 in<sup>3</sup></b>	12.5 L	<b>763 in<sup>3</sup></b>	12.5 L	<b>763 in<sup>3</sup></b>
Tires	<b>23.5R25</b>		<b>23.5R25</b>		<b>750/65/R26</b>	
Clearance Radius	8075 mm	<b>317.9"</b>	8075 mm	<b>317.9"</b>	8075 mm	<b>317.9"</b>
Fuel Tank Refill Capacity	412 L	<b>108.8 U.S. gal</b>	412 L	<b>108.8 U.S. gal</b>	412 L	<b>108.8 U.S. gal</b>
<b>General Dimensions (Empty):</b>						
Height to Cab Top	3482 mm	<b>137.1"</b>	3482 mm	<b>137.1"</b>	3461 mm	<b>136"</b>
Overall Length	10 547 mm	<b>415.2"</b>	10 555 mm	<b>415.6"</b>	10 376 mm	<b>408.5"</b>
Loading Height (Empty)	2725 mm	<b>107.3"</b>	2911 mm	<b>114.6"</b>	3025 mm	<b>119.1"</b>
Height at Full Dump	6306 mm	<b>248.3"</b>	6464 mm	<b>254.5"</b>	—	—
Body Length	5696 mm	<b>224.3"</b>	5783 mm	<b>227.7"</b>	5340 mm	<b>210.2"</b>
Width (Operating — Over Mirrors)	3704 mm	<b>145.8"</b>	3704 mm	<b>145.8"</b>	3704 mm	<b>145.8"</b>

\*Includes coolant, lubricant and full fuel tank.

\*\*Rating dependent on optional equipment. Maximum gross weight (empty weight plus payload) should not be exceeded.

<b>MODEL</b>	<b>735C</b>		<b>740C EJ</b>		<b>745C</b>	
Gross Power — SAE J1995	337 kW	<b>452 hp</b>	381 kW	<b>511 hp</b>	381 kW	<b>511 hp</b>
Net Power — SAE J1349	329 kW	<b>441 hp</b>	370 kW	<b>496 hp</b>	370 kW	<b>496 hp</b>
Net Power — ISO 14396	333 kW	<b>447 hp</b>	376 kW	<b>504 hp</b>	376 kW	<b>504 hp</b>
Operating Weight (Empty)*	31 500 kg	<b>69,446 lb</b>	36 000 kg	<b>79,366 lb</b>	33 400 kg	<b>73,634 lb</b>
Top Speed (Loaded)	53.9 km/h	<b>33.5 mph</b>	54.8 km/h	<b>34 mph</b>	54.8 km/h	<b>34 mph</b>
Gross Machine Weight	64 200 kg	<b>141,537 lb</b>	74 000 kg	<b>163,142 lb</b>	74 400 kg	<b>164,024 lb</b>
Distribution Empty:						
Front		<b>60%</b>		<b>57%</b>		<b>58%</b>
Center		<b>19%</b>		<b>22%</b>		<b>21%</b>
Rear		<b>21%</b>		<b>21%</b>		<b>21%</b>
Distribution Loaded:						
Front		<b>34%</b>		<b>30%</b>		<b>35%</b>
Center		<b>33%</b>		<b>35%</b>		<b>33%</b>
Rear		<b>33%</b>		<b>35%</b>		<b>32%</b>
Max. Capacity**	32.7 t	<b>36T</b>	38 t	<b>42T</b>	41 t	<b>45.2T</b>
Struck (SAE)	15 m <sup>3</sup>	<b>19.6 yd<sup>3</sup></b>	18 m <sup>3</sup>	<b>23.5 yd<sup>3</sup></b>	18.5 m <sup>3</sup>	<b>24.2 yd<sup>3</sup></b>
Heaped (2:1) (SAE)	20.5 m <sup>3</sup>	<b>26.8 yd<sup>3</sup></b>	23 m <sup>3</sup>	<b>30.1 yd<sup>3</sup></b>	25 m <sup>3</sup>	<b>32.7 yd<sup>3</sup></b>
Tailgate Heaped SAE 2:1	22 m <sup>3</sup>	<b>28.7 yd<sup>3</sup></b>	—	—	26.5 m <sup>3</sup>	<b>34.7 yd<sup>3</sup></b>
Tailgate Struck	15.5 m <sup>3</sup>	<b>20.3 yd<sup>3</sup></b>	—	—	19.5 m <sup>3</sup>	<b>25.5 yd<sup>3</sup></b>
Engine Model	<b>C15 ACERT</b>		<b>C18 ACERT</b>		<b>C18 ACERT</b>	
No. Cylinders	<b>6</b>		<b>6</b>		<b>6</b>	
Bore	137 mm	<b>5.4"</b>	145 mm	<b>5.7"</b>	145 mm	<b>5.7"</b>
Stroke	171.5 mm	<b>6.75"</b>	183 mm	<b>7.2"</b>	183 mm	<b>7.2"</b>
Displacement	15.2 L	<b>926 in<sup>3</sup></b>	18.1 L	<b>1106 in<sup>3</sup></b>	18.1 L	<b>1106 in<sup>3</sup></b>
Tires	<b>26.5R25</b>		<b>29.5R25</b>		<b>29.5R25</b>	
Clearance Radius	8420 mm	<b>331.5"</b>	9082 mm	<b>357.6"</b>	9082 mm	<b>357.6"</b>
Fuel Tank Refill Capacity	550 L	<b>145.3 U.S. gal</b>	550 L	<b>145.3 U.S. gal</b>	550 L	<b>145.3 U.S. gal</b>
DEF Tank Capacity	25 L	<b>6.6 U.S. gal</b>	25 L	<b>6.6 U.S. gal</b>	25 L	<b>6.6 U.S. gal</b>
<b>General Dimensions (Empty):</b>						
Height to Cab Top	3684 mm	<b>145.0"</b>	3725 mm	<b>146.7"</b>	3725 mm	<b>146.7"</b>
Overall Length	11 061 mm	<b>435.5"</b>	11 776 mm	<b>463.6"</b>	11 429 mm	<b>450.0"</b>
Loading Height (Empty)	2932 mm	<b>115.4"</b>	2987 mm	<b>117.6"</b>	3101 mm	<b>122.1"</b>
Height at Full Dump	6550 mm	<b>257.9"</b>	—	—	7239 mm	<b>285.0"</b>
Body Length	5912 mm	<b>232.8"</b>	6761 mm	<b>266.2"</b>	6447 mm	<b>253.8"</b>
Width (Operating — Over Mirrors)	4166 mm	<b>164.0"</b>	4166 mm	<b>164.0"</b>	4166 mm	<b>164.0"</b>

\*Includes coolant, lubricant and full fuel tank.

\*\*Rating dependent on optional equipment. Maximum gross weight (empty weight plus payload) should not be exceeded.

MODEL	735C		740C EJ		745C	
Gross Power — SAE J1995	336 kW	<b>450 hp</b>	381 kW	<b>511 hp</b>	381 kW	<b>511 hp</b>
Net Power — SAE J1349	329 kW	<b>441 hp</b>	370 kW	<b>496 hp</b>	370 kW	<b>496 hp</b>
Net Power — ISO 14396	333 kW	<b>447 hp</b>	376 kW	<b>484 hp</b>	376 kW	<b>484 hp</b>
Operating Weight (Empty)*	31 200 kg	<b>68,784 lb</b>	35 600 kg	<b>78,484 lb</b>	33 000 kg	<b>72,752 lb</b>
Top Speed (Loaded)	53.9 km/h	<b>33.5 mph</b>	54.8 km/h	<b>34 mph</b>	54.8 km/h	<b>34 mph</b>
Gross Machine Weight	63 900 kg	<b>140,875 lb</b>	73 600 kg	<b>162,260 lb</b>	74 000 kg	<b>163,142 lb</b>
Distribution Empty:						
Front		<b>60%</b>		<b>56%</b>		<b>58%</b>
Center		<b>19%</b>		<b>23%</b>		<b>21%</b>
Rear		<b>21%</b>		<b>21%</b>		<b>21%</b>
Distribution Loaded:						
Front		<b>33%</b>		<b>29%</b>		<b>34%</b>
Center		<b>33%</b>		<b>36%</b>		<b>33%</b>
Rear		<b>34%</b>		<b>35%</b>		<b>33%</b>
Max. Capacity**	32.7 t	<b>36T</b>	38 t	<b>42T</b>	41 t	<b>45.2T</b>
Struck (SAE)	15 m <sup>3</sup>	<b>19.6 yd<sup>3</sup></b>	18 m <sup>3</sup>	<b>23.5 yd<sup>3</sup></b>	18.5 m <sup>3</sup>	<b>24.2 yd<sup>3</sup></b>
Heaped (2:1) (SAE)	20.5 m <sup>3</sup>	<b>26.8 yd<sup>3</sup></b>	23 m <sup>3</sup>	<b>30.1 yd<sup>3</sup></b>	25 m <sup>3</sup>	<b>32.7 yd<sup>3</sup></b>
Tailgate Heaped SAE 2:1	22 m <sup>3</sup>	<b>28.7 yd<sup>3</sup></b>		—	26.5 m <sup>3</sup>	<b>34.7 yd<sup>3</sup></b>
Tailgate Struck	15.5 m <sup>3</sup>	<b>20.3 yd<sup>3</sup></b>		—	19.5 m <sup>3</sup>	<b>25.5 yd<sup>3</sup></b>
Engine Model	<b>C15 ACERT</b>		<b>C18 ACERT</b>		<b>C18 ACERT</b>	
No. Cylinders	<b>6</b>		<b>6</b>		<b>6</b>	
Bore	137 mm	<b>5.4"</b>	145 mm	<b>5.7"</b>	145 mm	<b>5.7"</b>
Stroke	171.5 mm	<b>6.75"</b>	183 mm	<b>7.2"</b>	183 mm	<b>7.2"</b>
Displacement	15.2 L	<b>926 in<sup>3</sup></b>	18.1 L	<b>1106 in<sup>3</sup></b>	18.1 L	<b>1106 in<sup>3</sup></b>
Tires	<b>26.5R25</b>		<b>29.5R25</b>		<b>29.5R25</b>	
Clearance Radius	8420 mm	<b>331.5"</b>	9082 mm	<b>357.6"</b>	9082 mm	<b>357.6"</b>
Fuel Tank Refill Capacity	550 L	<b>145.3 U.S. gal</b>	550 L	<b>145.3 U.S. gal</b>	550 L	<b>145.3 U.S. gal</b>
<b>General Dimensions (Empty):</b>						
Height to Cab Top	3684 mm	<b>145.0"</b>	3725 mm	<b>146.7"</b>	3725 mm	<b>146.7"</b>
Overall Length	11 061 mm	<b>435.5"</b>	11 776 mm	<b>463.6"</b>	11 429 mm	<b>450.0"</b>
Loading Height (Empty)	2932 mm	<b>115.4"</b>	2987 mm	<b>117.6"</b>	3101 mm	<b>122.1"</b>
Height at Full Dump	6550 mm	<b>257.9"</b>		—	7239 mm	<b>285.0"</b>
Body Length	5912 mm	<b>232.8"</b>	6761 mm	<b>266.2"</b>	6447 mm	<b>253.8"</b>
Width (Operating — Over Mirrors)	4166 mm	<b>164.0"</b>	4166 mm	<b>164.0"</b>	4166 mm	<b>164.0"</b>

\*Includes coolant, lubricant and full fuel tank.

\*\*Rating dependent on optional equipment. Maximum gross weight (empty weight plus payload) should not be exceeded.

### Use of Ground Pressure Charts

Articulated trucks are normally equipped with wide base radial tires, for improved flotation in poor underfoot conditions. Ground pressure is a function of tire deflection and is also affected by tire penetration. The charts in this section provide a means to estimate ground pressure for 0 and 76 mm (3") tire penetration, when gross vehicle weight, axle load distribution and tire inflation pressure are known. The ground pressure charts on the following pages are based on Michelin XADN tire characteristics. Results may differ for other tread patterns.

Tire load can be calculated by the following formula:

$$\text{Tire Load} = \frac{\text{Heaviest Axle Load}}{2}$$

#### Example

Find the ground pressure generated by a 725C fully loaded with zero and 76 mm (3") tire penetration. The machine is equipped with standard Michelin 23.5R25 tires, inflated to the recommended pressure.

$$725\text{C Tire Load} = \frac{46\,820 \text{ kg} \times 0.34}{2} = 7959 \text{ kg}$$

$$725\text{C Tire Load} = \frac{103,220 \text{ lb} \times 0.34}{2} = 17,547 \text{ lb}$$

From the tire section in this book, inflation pressure for the 725C is 325 kPa = 3.25 bar (47 psi).

From the ground pressure chart for 23.5R25 tires, Ground pressure = 3.1 kg/cm<sup>2</sup> (44 psi) with zero tire penetration.

Ground pressure = 1.4 kg/cm<sup>2</sup> (21 psi) with 76 mm (3") tire penetration.

See the Wheel Tractor Scraper section for explanation on using:

- Rimpull-Speed-Gradeability Curves
- Retarder Curves

See Mining & Off-Highway Trucks section for Fixed Times for Hauling Units.

### 23.5R25 Tires\*

### 30/65R25 Tires\*

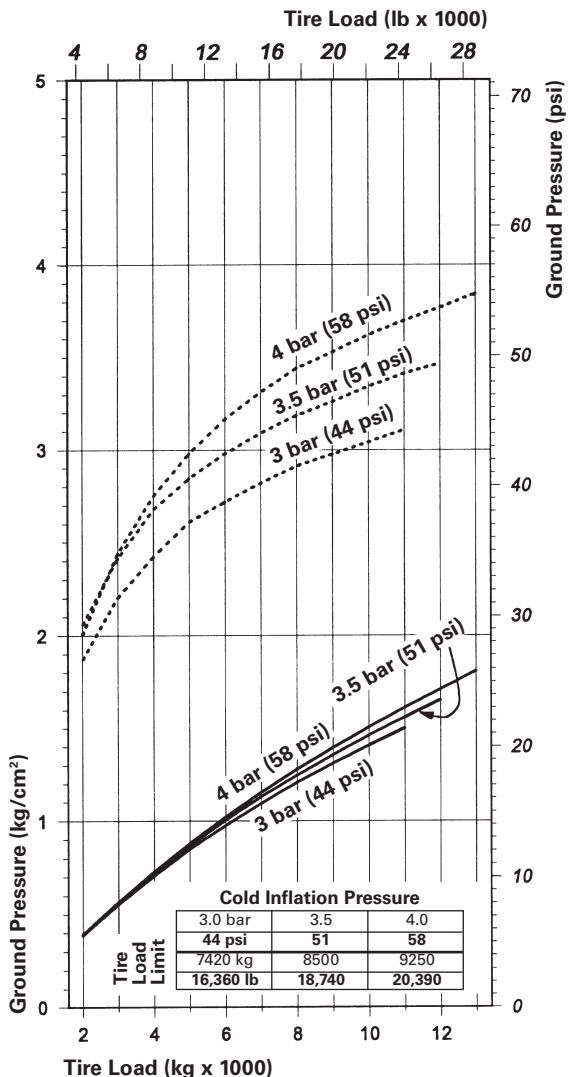
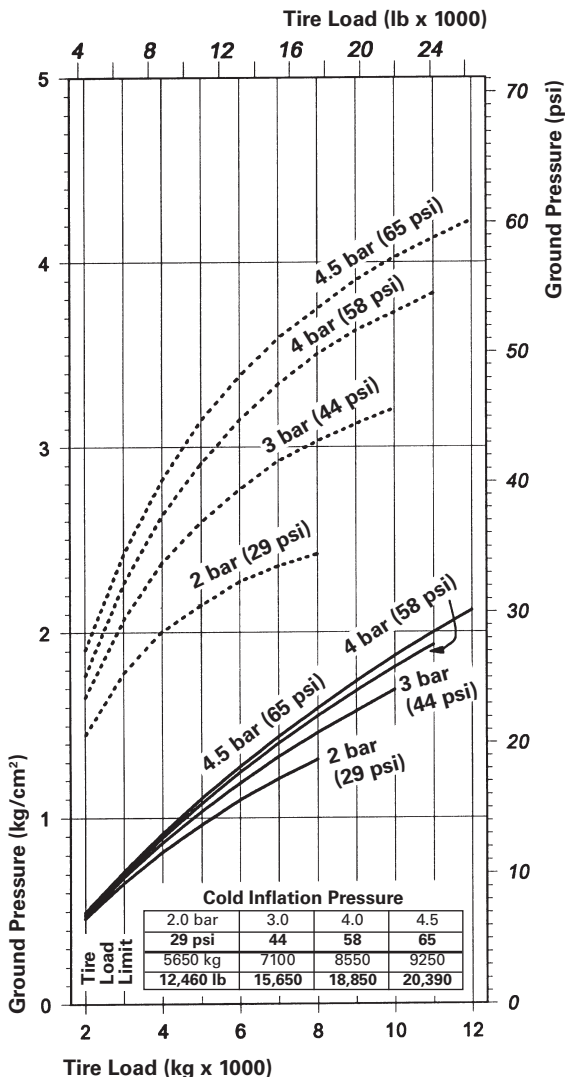

**KEY**

- Zero Penetration (Flat Plate)
- 76 mm (3") Penetration

\*Charts based on Michelin XADN tire characteristics. Results may differ for other tread patterns and/or brands. Charts are to be used to calculate ground pressure. To determine the inflation as a function of load and conditions or when loads exceed tire load limit, contact your tire manufacturer representative.

**26.5R25 Tires\***

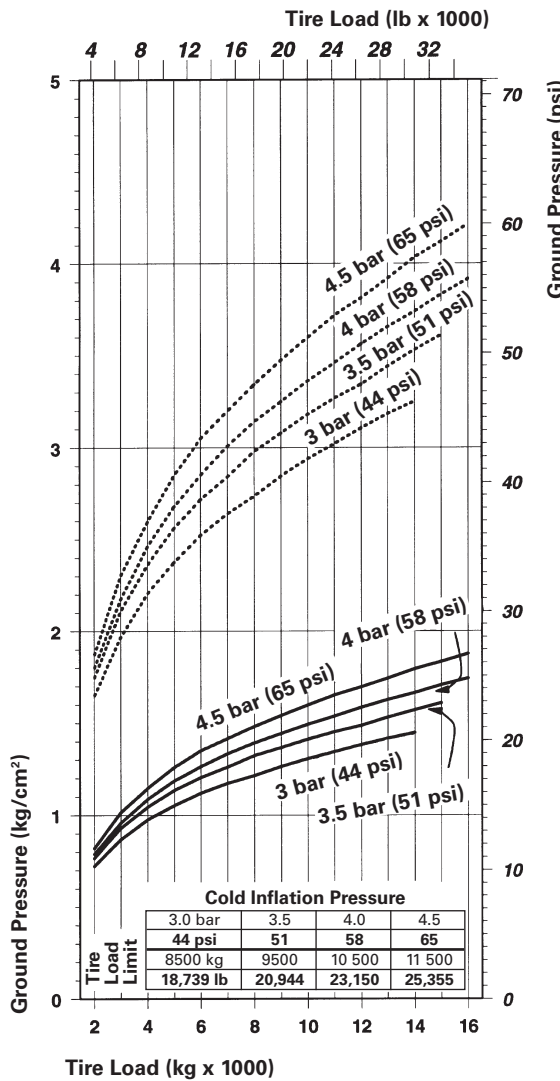

**29.5R25 Tires\***

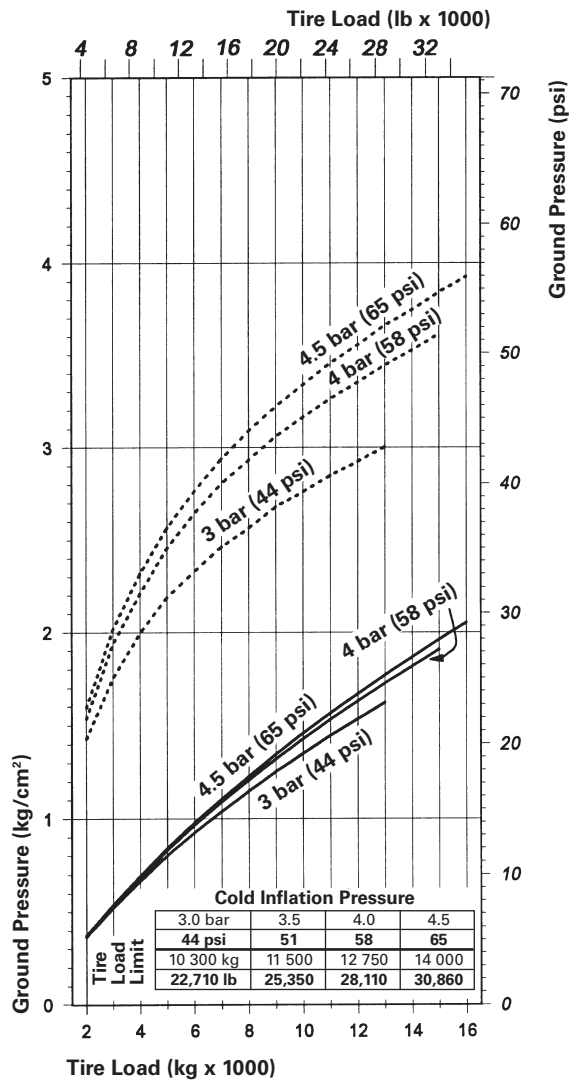

**KEY**

- Zero Penetration (Flat Plate)
- 76 mm (3") Penetration

\*Charts based on Michelin XADN tire characteristics. Results may differ for other tread patterns and/or brands. Charts are to be used to calculate ground pressure. To determine the inflation as a function of load and conditions or when loads exceed tire load limit, contact your tire manufacturer representative.

- 23.5R25 Tires
- Tier 4 Final/Stage IV/Japan 2014 (Tier 4 Final)

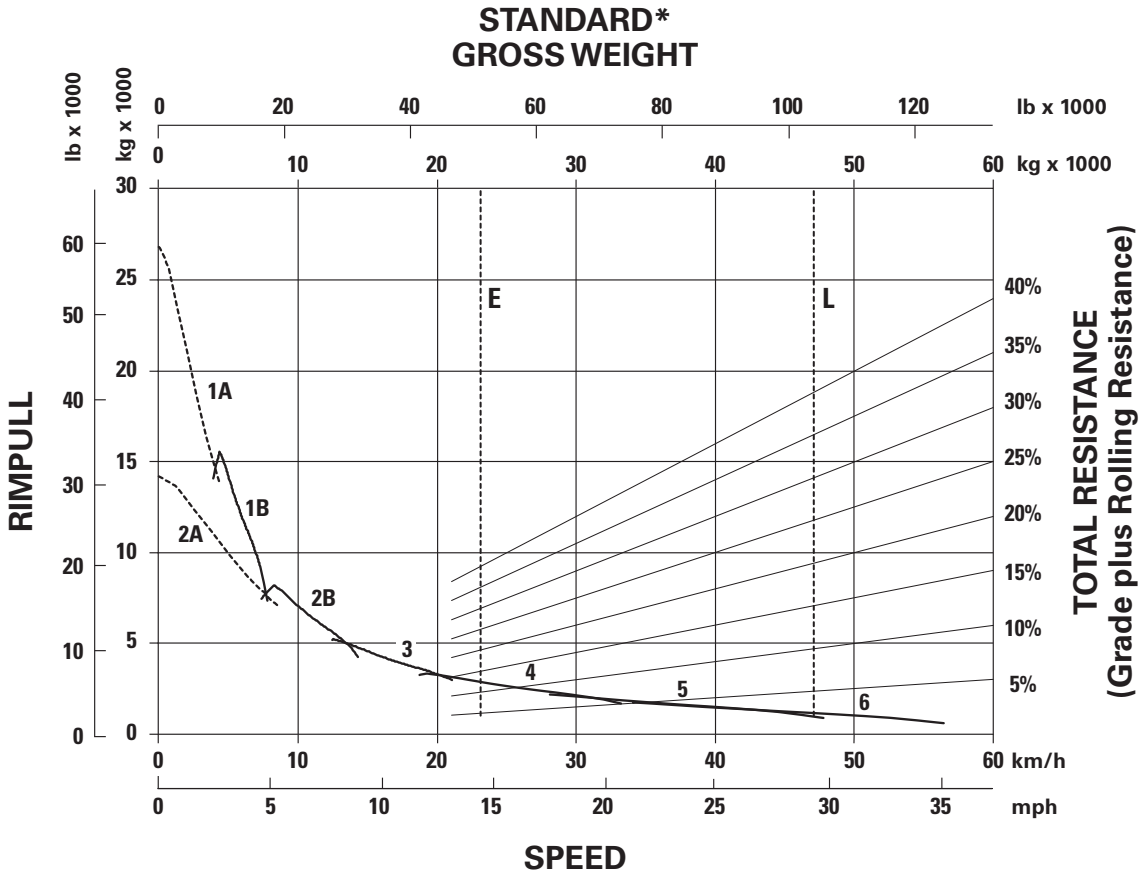

**KEY**

- 1A – 1st Gear (Converter Drive)
- 1B – 1st Gear (Direct Drive)
- 2A – 2nd Gear (Converter Drive)
- 2B – 2nd Gear (Direct Drive)
- 3 – 3rd Gear
- 4 – 4th Gear
- 5 – 5th Gear
- 6 – 6th Gear

**KEY**

- E – Empty 23 040 kg (50,795 lb)
- L – Loaded 47 040 kg (103,707 lb)

\*At sea level.



# Articulated Trucks

## 725C2 Brake/Retarder Performance Curve

- 23.5R25 Tires
- Tier 4 Final/Stage IV/Japan 2014 (Tier 4 Final)

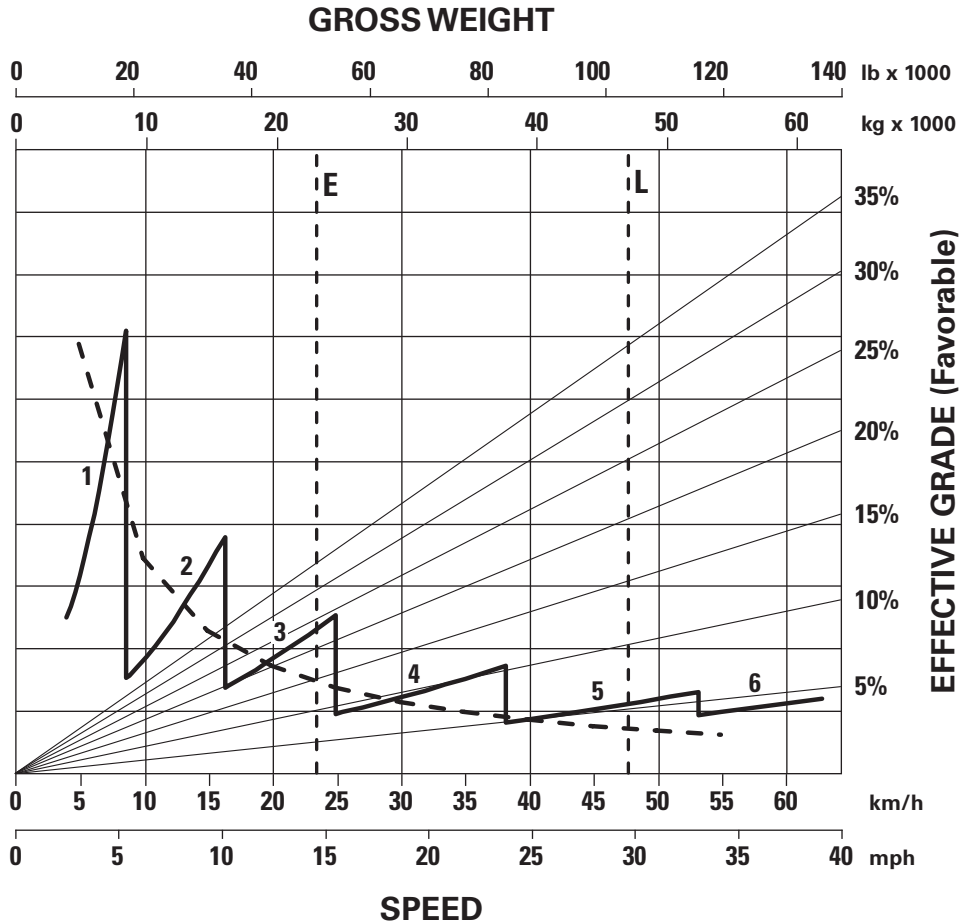

### KEY

- 1 — 1st Gear
- 2 — 2nd Gear
- 3 — 3rd Gear
- 4 — 4th Gear
- 5 — 5th Gear
- 6 — 6th Gear

### KEY

- E — Empty 23 040 kg (50,795 lb)
- L — Loaded 47 040 kg (103,707 lb)

- 23.5R25 Tires
- Tier 2/Stage II/Japan 2001 (Tier 2) equivalent

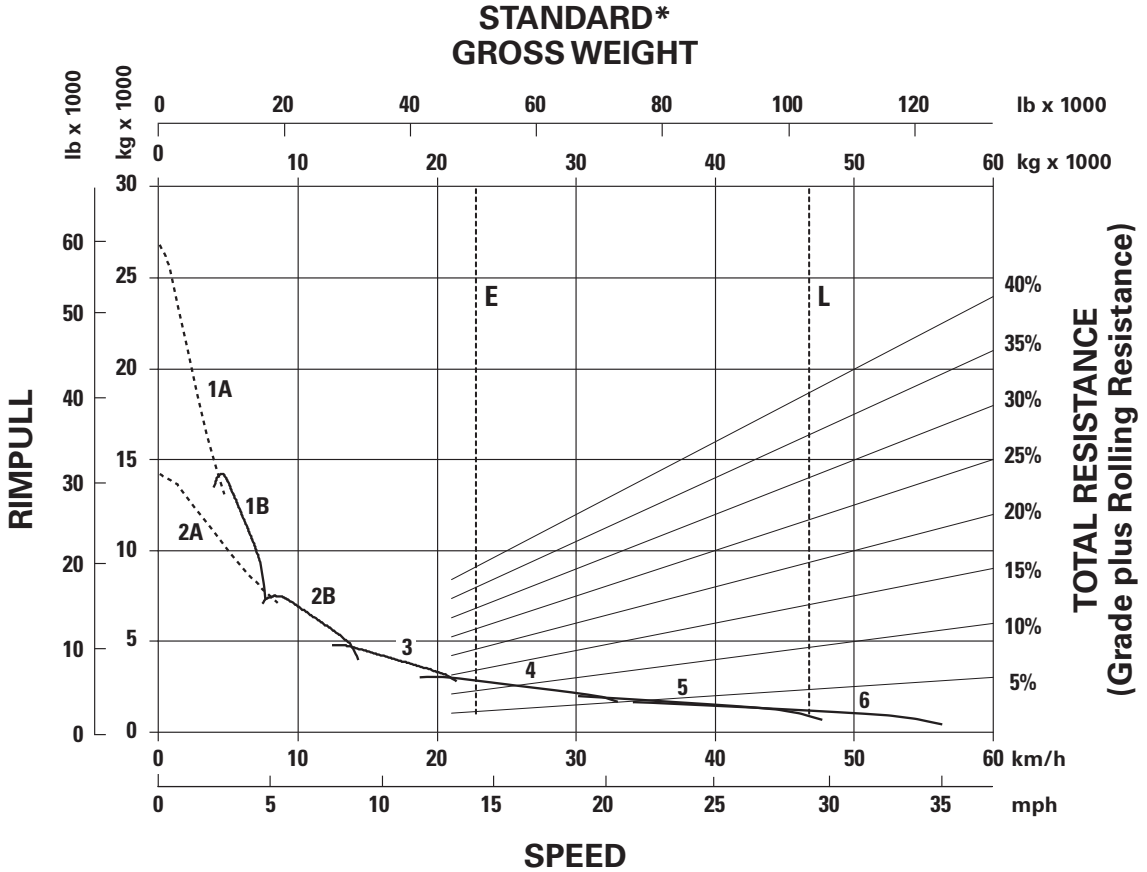

**KEY**

- 1A – 1st Gear (Converter Drive)
- 1B – 1st Gear (Direct Drive)
- 2A – 2nd Gear (Converter Drive)
- 2B – 2nd Gear (Direct Drive)
- 3 – 3rd Gear
- 4 – 4th Gear
- 5 – 5th Gear
- 6 – 6th Gear

**KEY**

- E – Empty 22 775 kg (50,211 lb)
- L – Loaded 46 775 kg (103,121 lb)

\*At sea level.

# Articulated Trucks

## 725C2 Brake/Retarder Performance Curve

- 23.5R25 Tires
- Tier 2/Stage II/Japan 2001 (Tier 2) equivalent

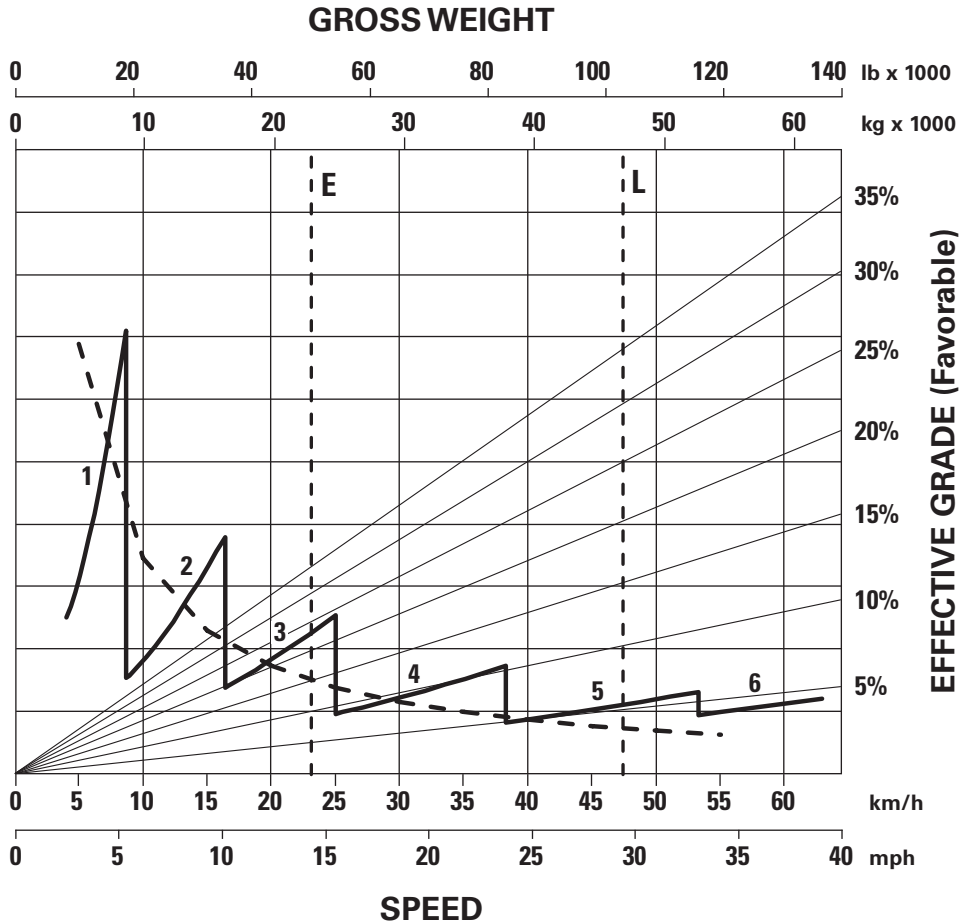

### KEY

- 1 — 1st Gear
- 2 — 2nd Gear
- 3 — 3rd Gear
- 4 — 4th Gear
- 5 — 5th Gear
- 6 — 6th Gear

### KEY

- E — Empty 22 775 kg (50,211 lb)
- L — Loaded 46 775 kg (103,121 lb)

● 23.5R25 Tires

● Tier 4 Final/Stage IV/Japan 2014 (Tier 4 Final)

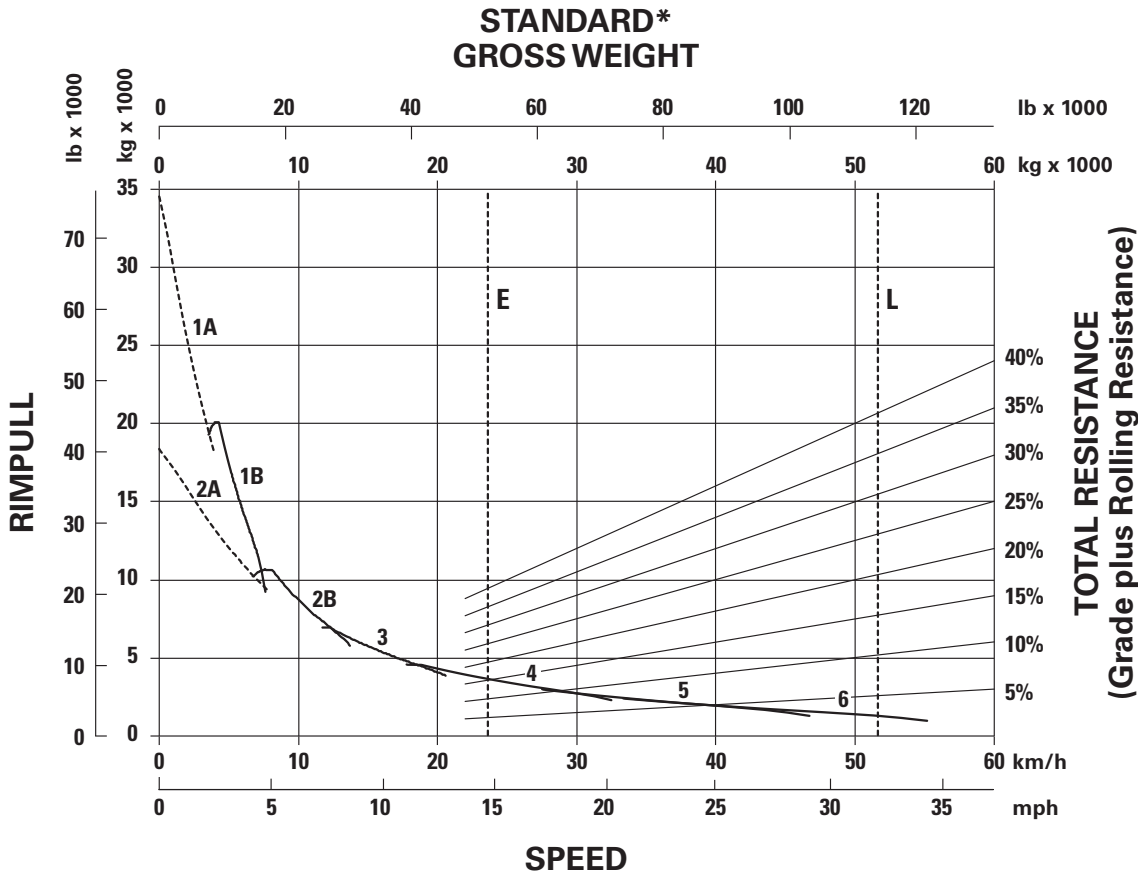

**KEY**

- 1A – 1st Gear (Converter Drive)
- 1B – 1st Gear (Direct Drive)
- 2A – 2nd Gear (Converter Drive)
- 2B – 2nd Gear (Direct Drive)
- 3 – 3rd Gear
- 4 – 4th Gear
- 5 – 5th Gear
- 6 – 6th Gear

**KEY**

- E – Empty 23 725 kg (52,305 lb)
- L – Loaded 51 725 kg (114,034 lb)

\*At sea level.

# Articulated Trucks

## 730C2 Brake/Retarder Performance Curve

- 23.5R25 Tires
- Tier 4 Final/Stage IV/Japan 2014 (Tier 4 Final)

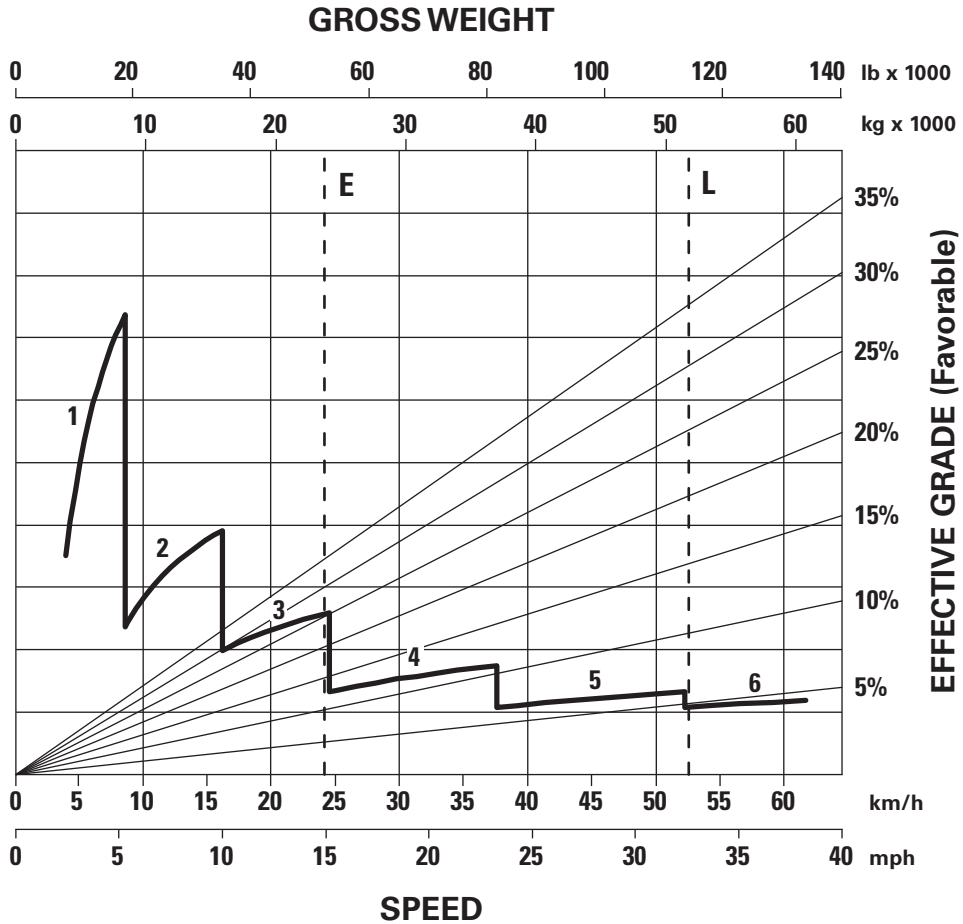

### KEY

- 1 — 1st Gear
- 2 — 2nd Gear
- 3 — 3rd Gear
- 4 — 4th Gear
- 5 — 5th Gear
- 6 — 6th Gear

### KEY

- E — Empty 23 725 kg (52,305 lb)
- L — Loaded 51 725 kg (114,034 lb)

# 730C2 Rimpull-Speed-Gradeability

- 23.5R25 Tires
- Tier 2/Stage II/Japan 2001 (Tier 2) equivalent

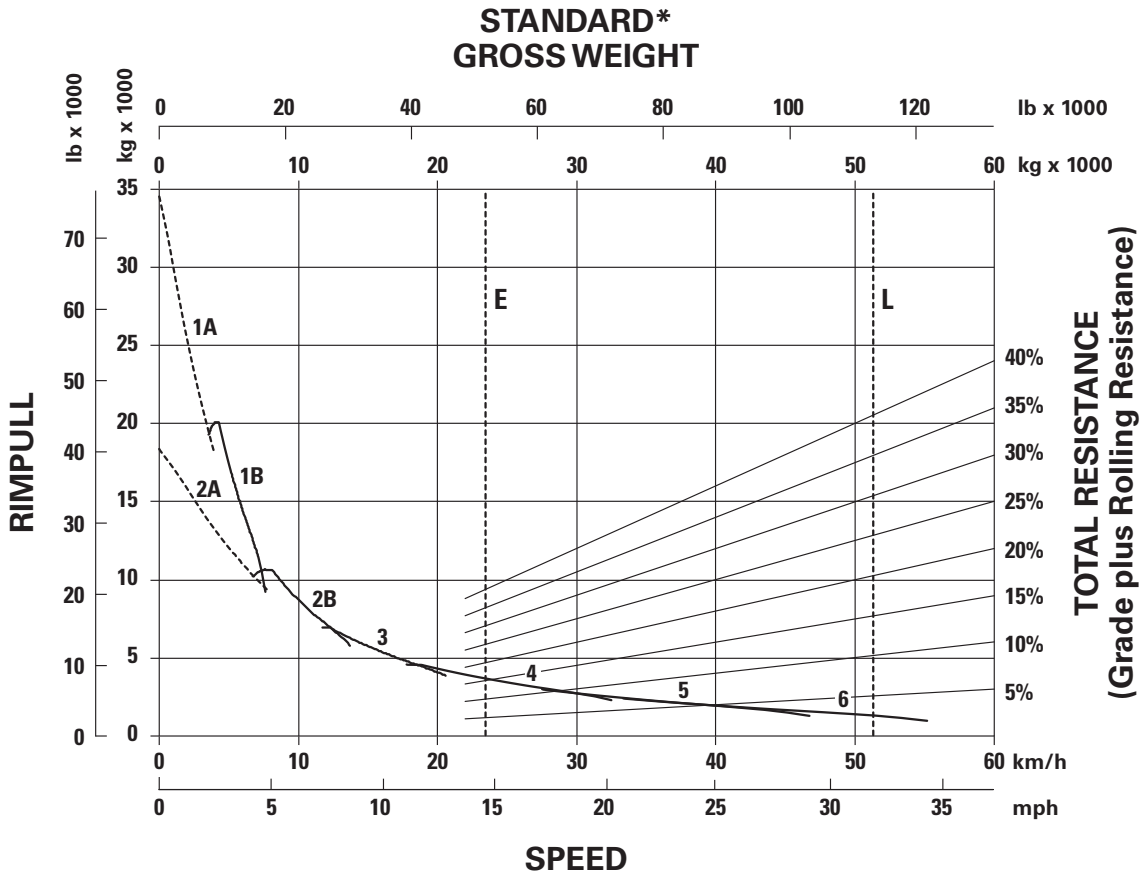

**KEY**

- 1A – 1st Gear (Converter Drive)
- 1B – 1st Gear (Direct Drive)
- 2A – 2nd Gear (Converter Drive)
- 2B – 2nd Gear (Direct Drive)
- 3 – 3rd Gear
- 4 – 4th Gear
- 5 – 5th Gear
- 6 – 6th Gear

**KEY**

- E – Empty 23 505 kg (51,378 lb)
- L – Loaded 51 305 kg (113,107 lb)

\*At sea level.

# Articulated Trucks

## 730C2 Brake/Retarder Performance Curve

- 23.5R25Tires
- Tier 2/Stage II/Japan 2001 (Tier 2) equivalent

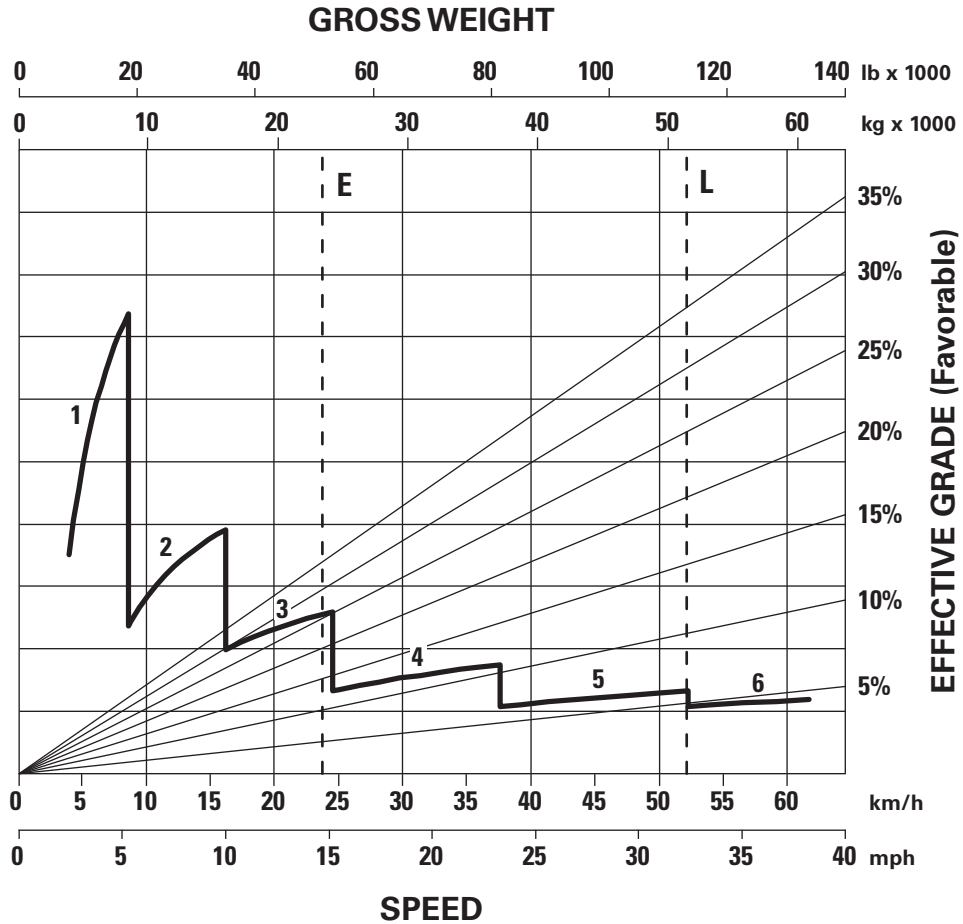

### KEY

- 1 — 1st Gear
- 2 — 2nd Gear
- 3 — 3rd Gear
- 4 — 4th Gear
- 5 — 5th Gear
- 6 — 6th Gear

### KEY

- E — Empty 23 505 kg (51,378 lb)
- L — Loaded 51 305 kg (113,107 lb)

● 750/65/R26 Tires

● Tier 4 Final/Stage IV/Japan 2014 (Tier 4 Final)

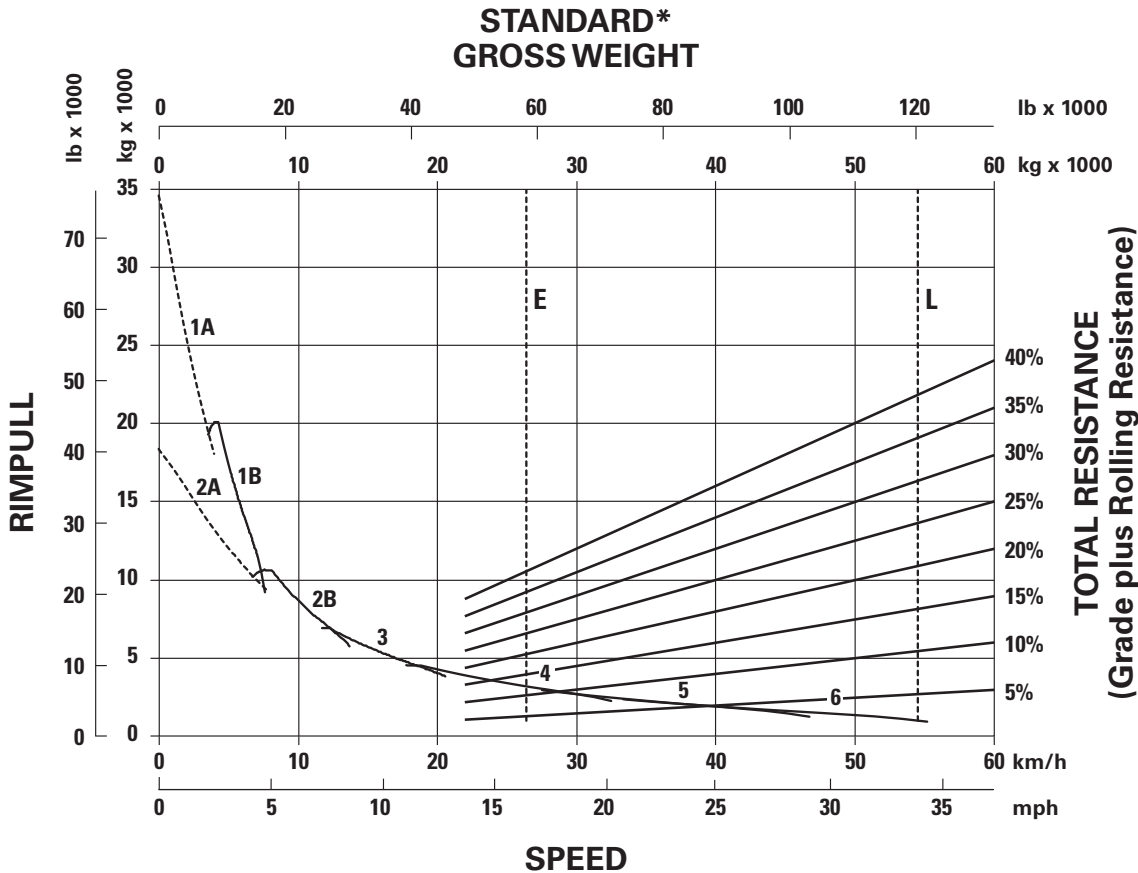

**KEY**

- 1A – 1st Gear (Converter Drive)
- 1B – 1st Gear (Direct Drive)
- 2A – 2nd Gear (Converter Drive)
- 2B – 2nd Gear (Direct Drive)
- 3 – 3rd Gear
- 4 – 4th Gear
- 5 – 5th Gear
- 6 – 6th Gear

**KEY**

- E – Empty 26 395 kg (58,190 lb)
- L – Loaded 54 515 kg (120,186 lb)

\*At sea level.



# Articulated Trucks

## 730C2 EJ Brake/Retarder Performance Curve

- 750/65/R26 Tires
- Tier 4 Final/Stage IV/Japan 2014 (Tier 4 Final)

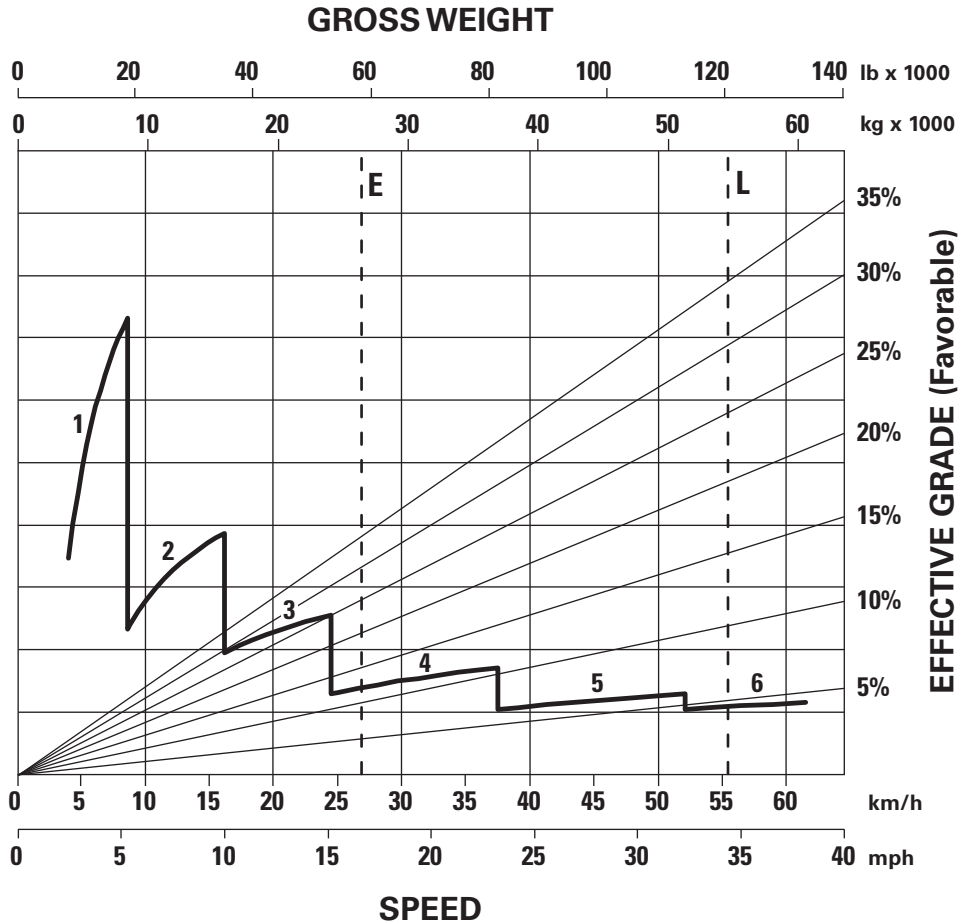

### KEY

- 1 – 1st Gear
- 2 – 2nd Gear
- 3 – 3rd Gear
- 4 – 4th Gear
- 5 – 5th Gear
- 6 – 6th Gear

### KEY

- E – Empty 26 395 kg (58,190 lb)
- L – Loaded 54 515 kg (120,186 lb)

- 750/65/R26 Tires
- Tier 2/Stage II/Japan 2001 (Tier 2) equivalent

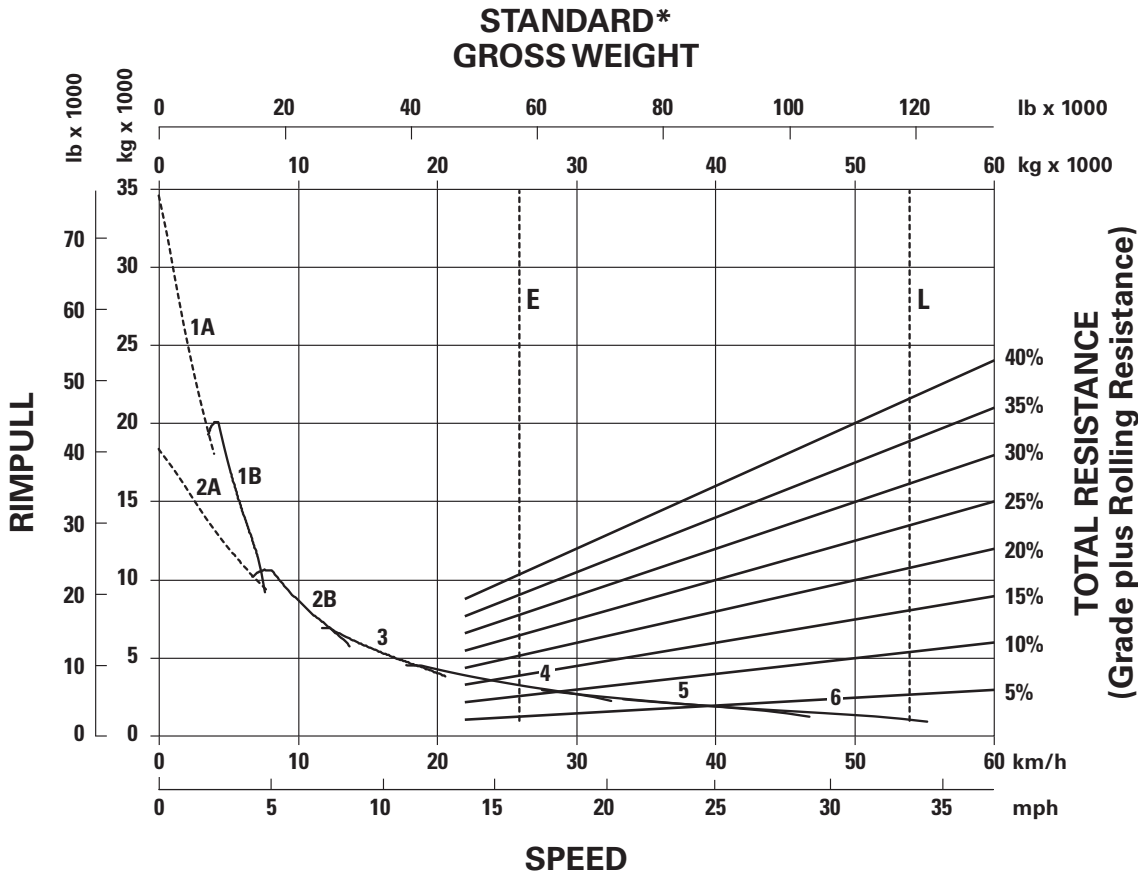

**KEY**

- 1A – 1st Gear (Converter Drive)
- 1B – 1st Gear (Direct Drive)
- 2A – 2nd Gear (Converter Drive)
- 2B – 2nd Gear (Direct Drive)
- 3 – 3rd Gear
- 4 – 4th Gear
- 5 – 5th Gear
- 6 – 6th Gear

**KEY**

- E – Empty 25 980 kg (57,277 lb)
- L – Loaded 54 100 kg (119,270 lb)

\*At sea level.

# Articulated Trucks

## 730C2 EJ Brake/Retarder Performance Curve

- 750/65/R26 Tires
- Tier 2/Stage II/Japan 2001 (Tier 2) equivalent

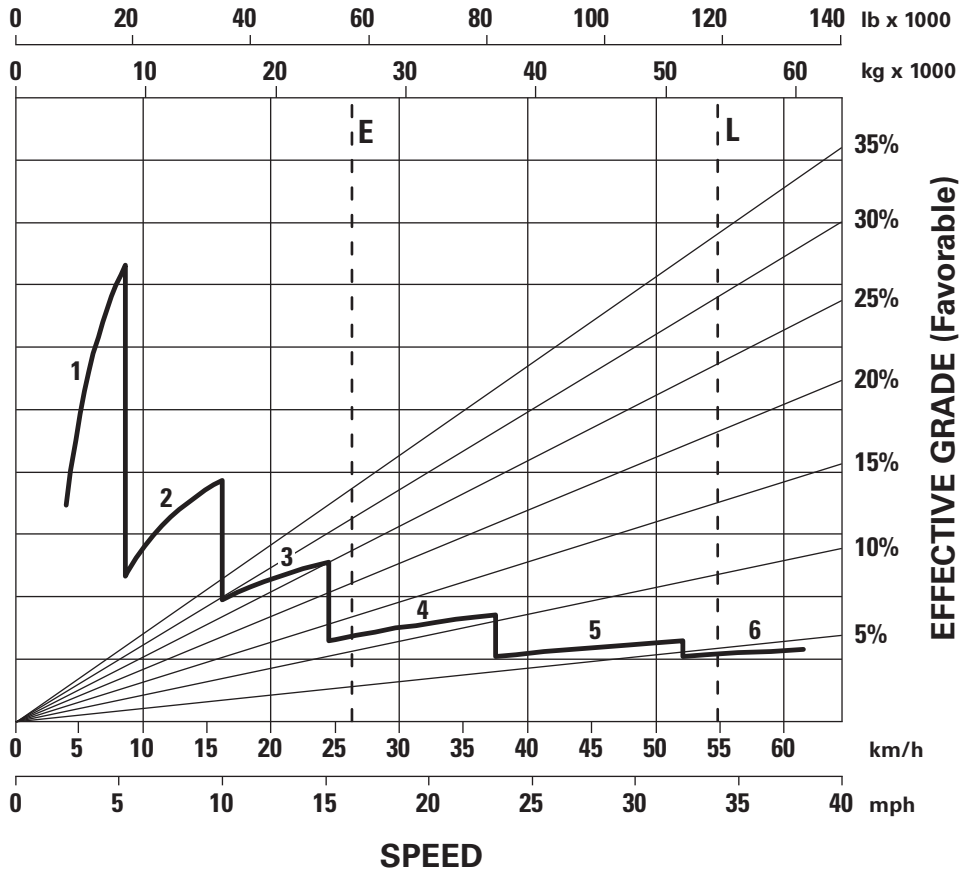

### KEY

- 1 — 1st Gear
- 2 — 2nd Gear
- 3 — 3rd Gear
- 4 — 4th Gear
- 5 — 5th Gear
- 6 — 6th Gear

### KEY

- E — Empty 25 980 kg (57,277 lb)
- L — Loaded 54 100 kg (119,270 lb)

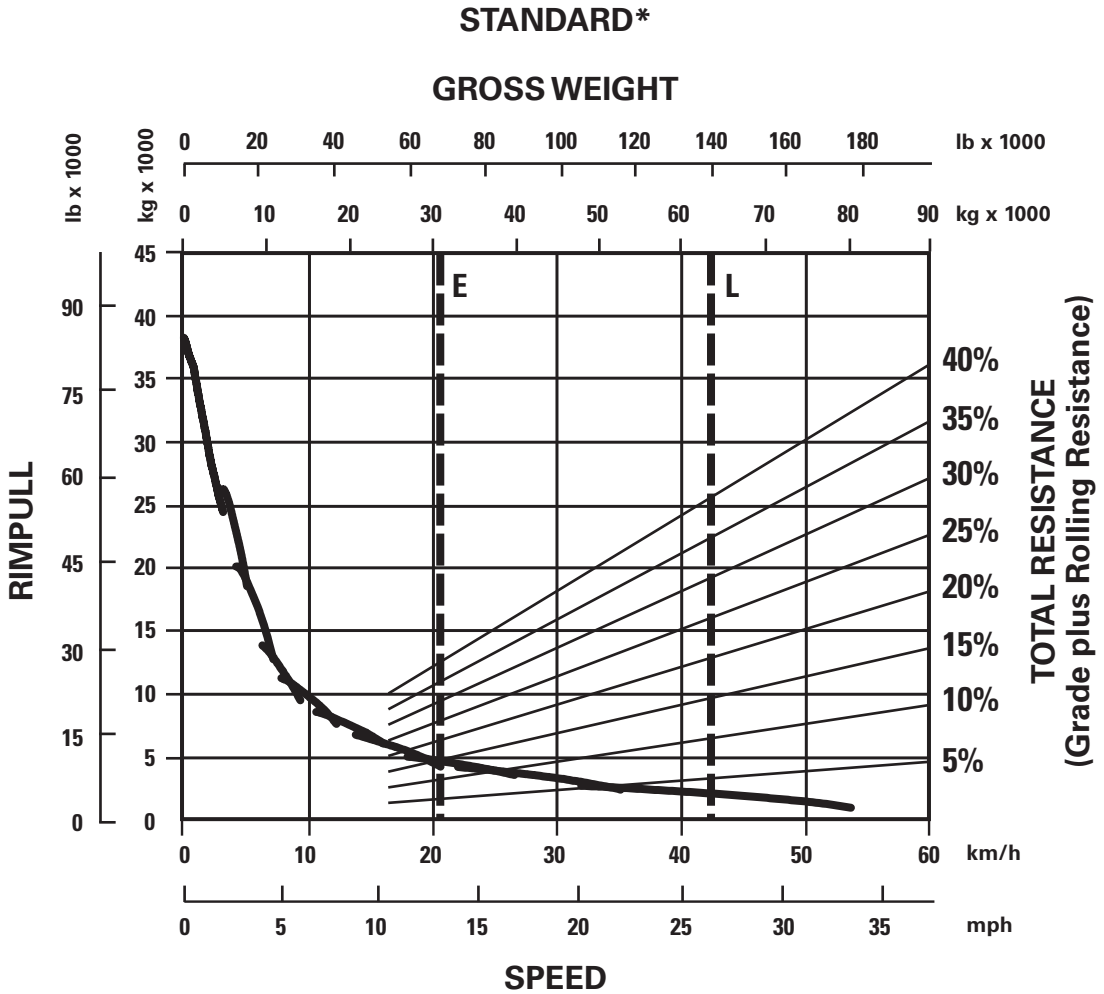

**KEY**

- E — Empty 31 220 kg (68,800 lb)
- L — Loaded 63 920 kg (140,900 lb)

\*At sea level.

# Articulated Trucks

## 735C Series Brake/Retarder Performance Curve

- 26.5R25Tires
- Tier 4 Final/Stage IV/Japan 2014 (Tier 4 Final)

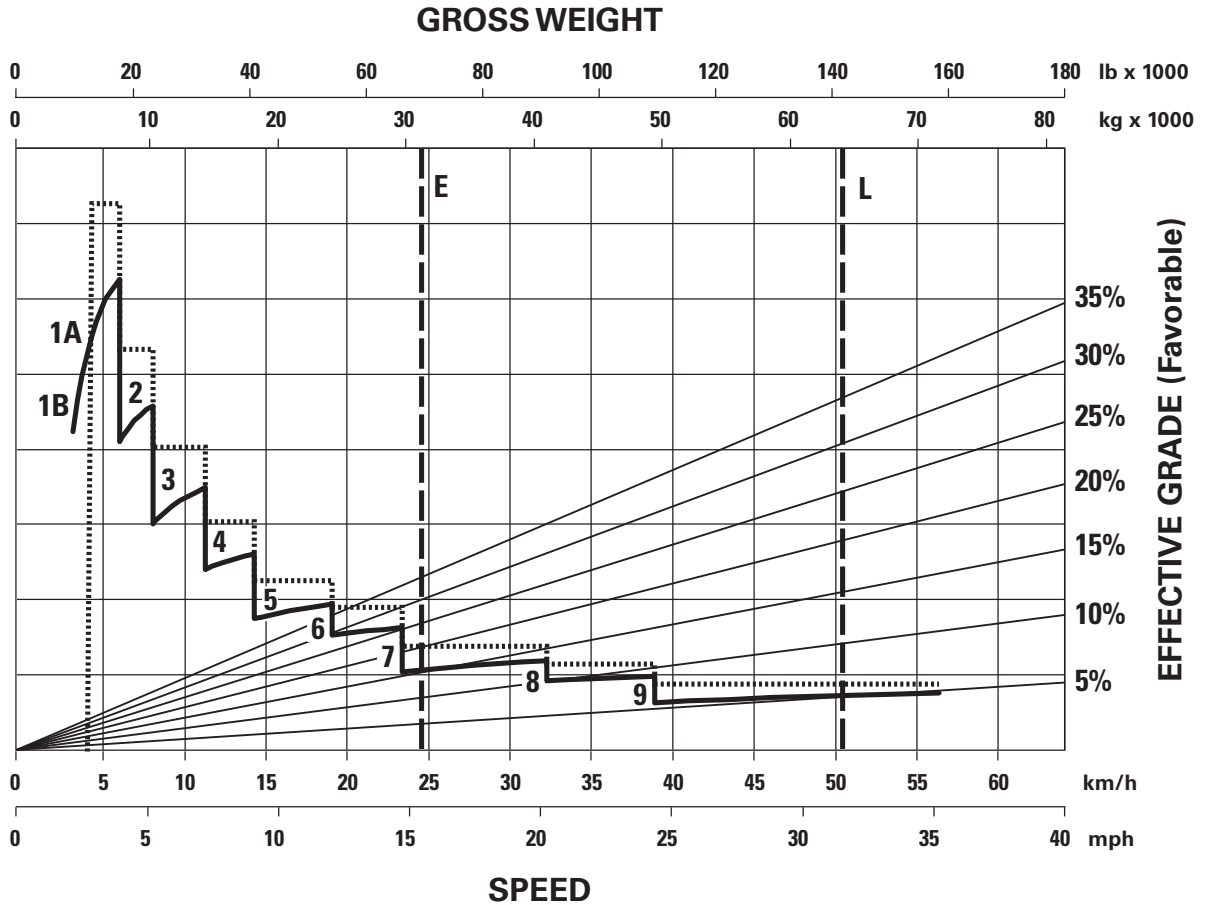

### KEY

- 1A – 1st Gear (Converter Drive)
- 1B – 1st Gear (Direct Drive)
- 2 – 2nd Gear
- 3 – 3rd Gear
- 4 – 4th Gear
- 5 – 5th Gear
- 6 – 6th Gear
- 7 – 7th Gear
- 8 – 8th Gear
- 9 – 9th Gear

### KEY

- E – Empty 31 400 kg (69,225 lb)
- L – Loaded 64 100 kg (141,316 lb)

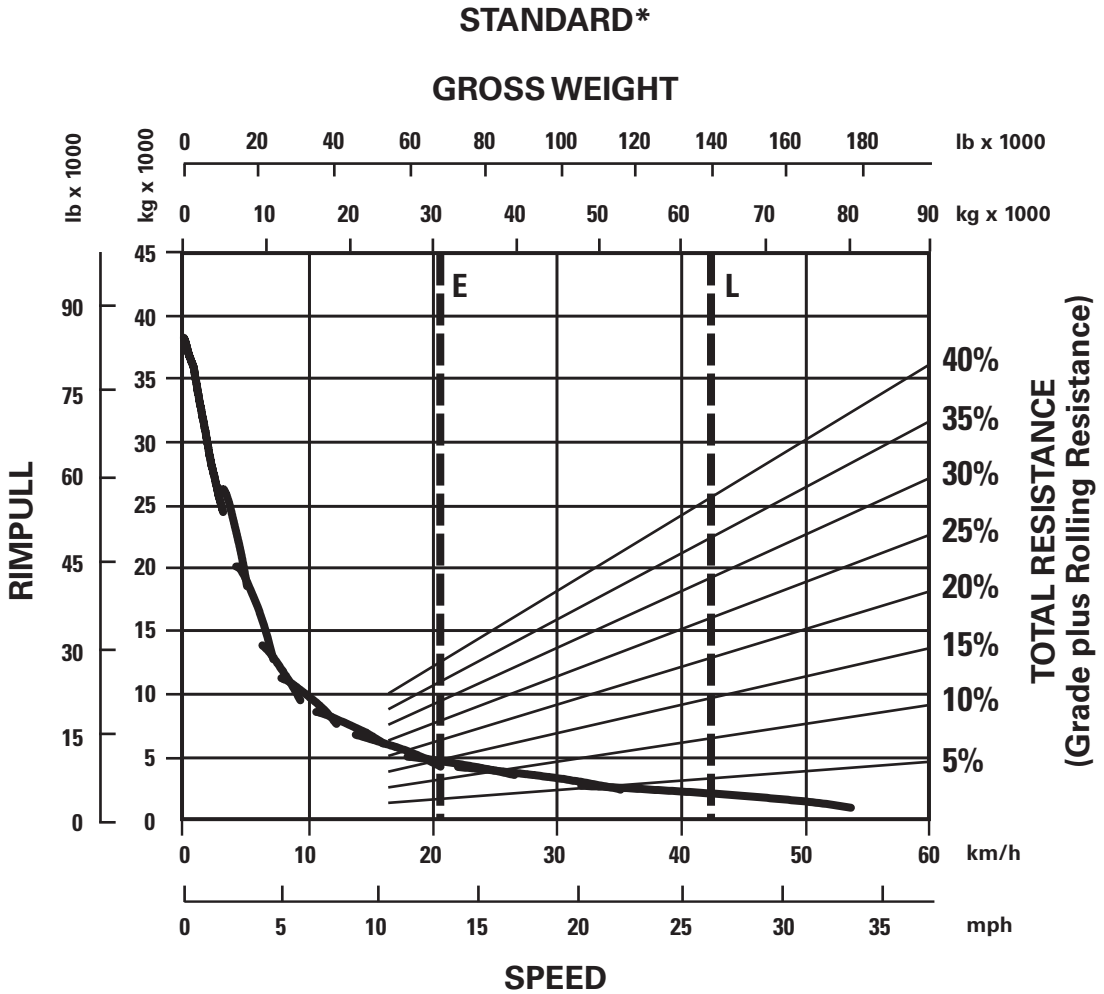

**KEY**

- E — Empty 31 220 kg (68,800 lb)
- L — Loaded 63 920 kg (140,900 lb)

\*At sea level.

# Articulated Trucks

## 735C Series Brake/Retarder Performance Curve

- 26.5R25Tires
- Tier 2/Stage II/Japan 2001 (Tier 2) equivalent

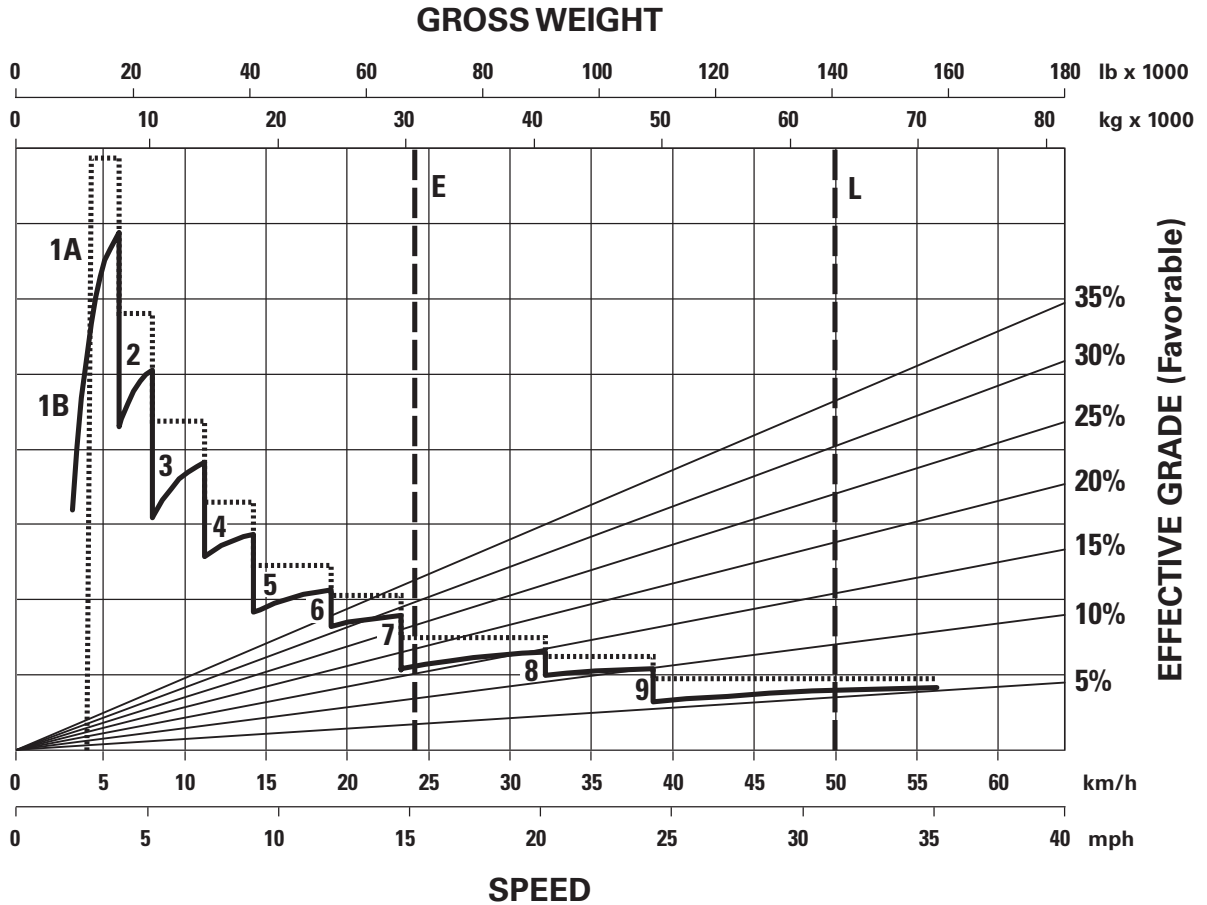

### KEY

- 1A – 1st Gear (Converter Drive)
- 1B – 1st Gear (Direct Drive)
- 2 – 2nd Gear
- 3 – 3rd Gear
- 4 – 4th Gear
- 5 – 5th Gear
- 6 – 6th Gear
- 7 – 7th Gear
- 8 – 8th Gear
- 9 – 9th Gear

### KEY

- E – Empty 30 970 kg (68,277 lb)
- L – Loaded 63 670 kg (140,368 lb)

**STANDARD\***

**GROSS WEIGHT**

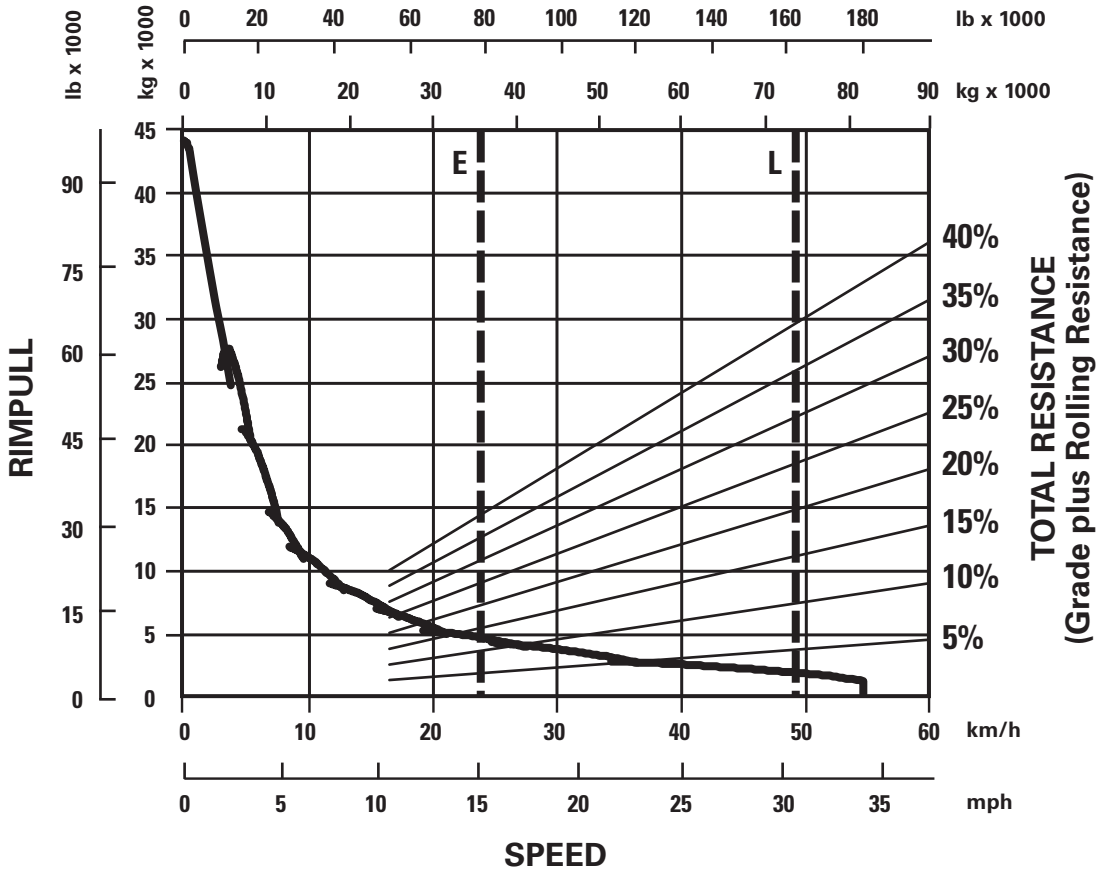

**KEY**

- E — Empty 36 000 kg (79,400 lb)
- L — Loaded 74 000 kg (163,100 lb)

\*At sea level.



# Articulated Trucks

## 740C EJ Series Brake/Retarder Performance Curve

- 29.5R25Tires
- Tier 4 Final/Stage IV/Japan 2014 (Tier 4 Final)

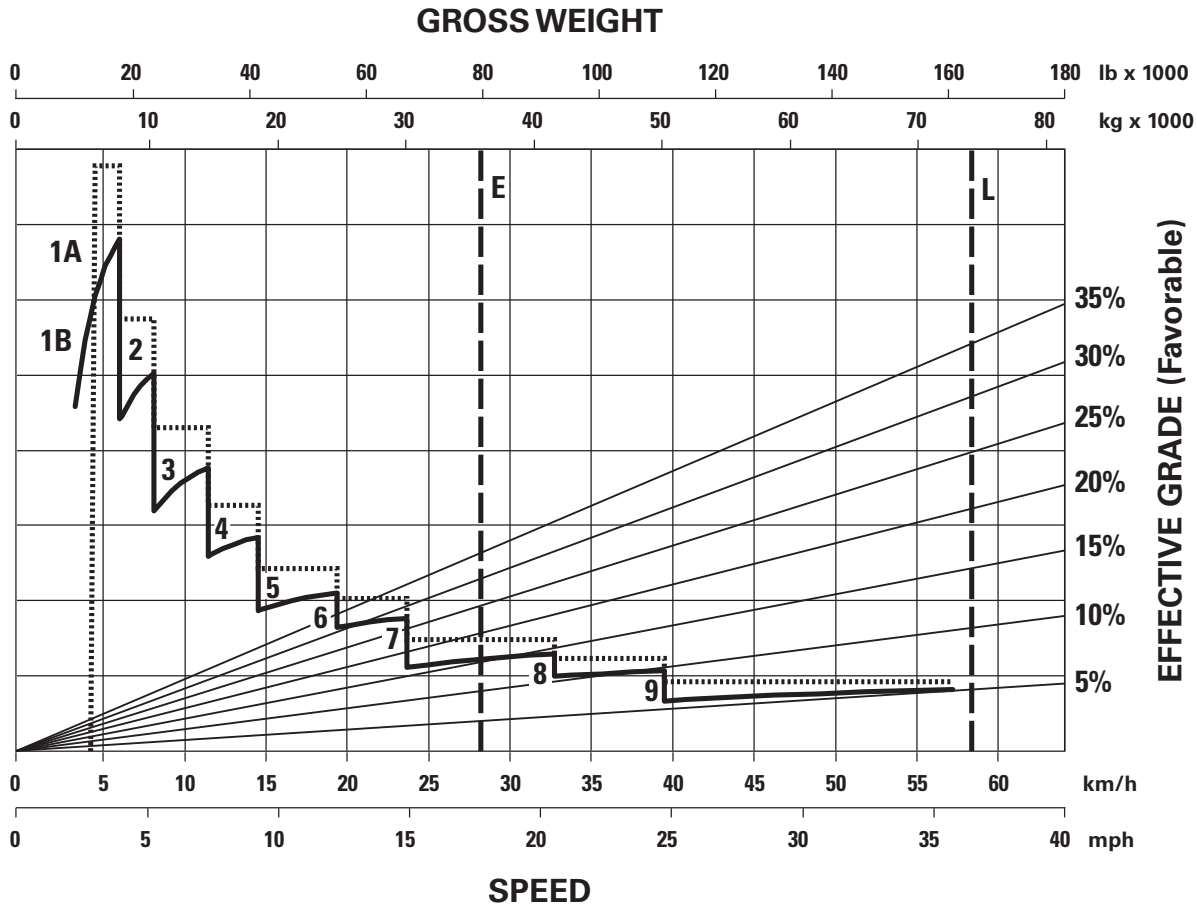

**KEY**

- 1A – 1st Gear (Converter Drive)
- 1B – 1st Gear (Direct Drive)
- 2 – 2nd Gear
- 3 – 3rd Gear
- 4 – 4th Gear
- 5 – 5th Gear
- 6 – 6th Gear
- 7 – 7th Gear
- 8 – 8th Gear
- 9 – 9th Gear

**KEY**

- E – Empty 36 070 kg (79,521 lb)
- L – Loaded 74 070 kg (163,296 lb)

- 29.5R25 Tires
- Tier 2/Stage II/Japan 2001 (Tier 2) equivalent

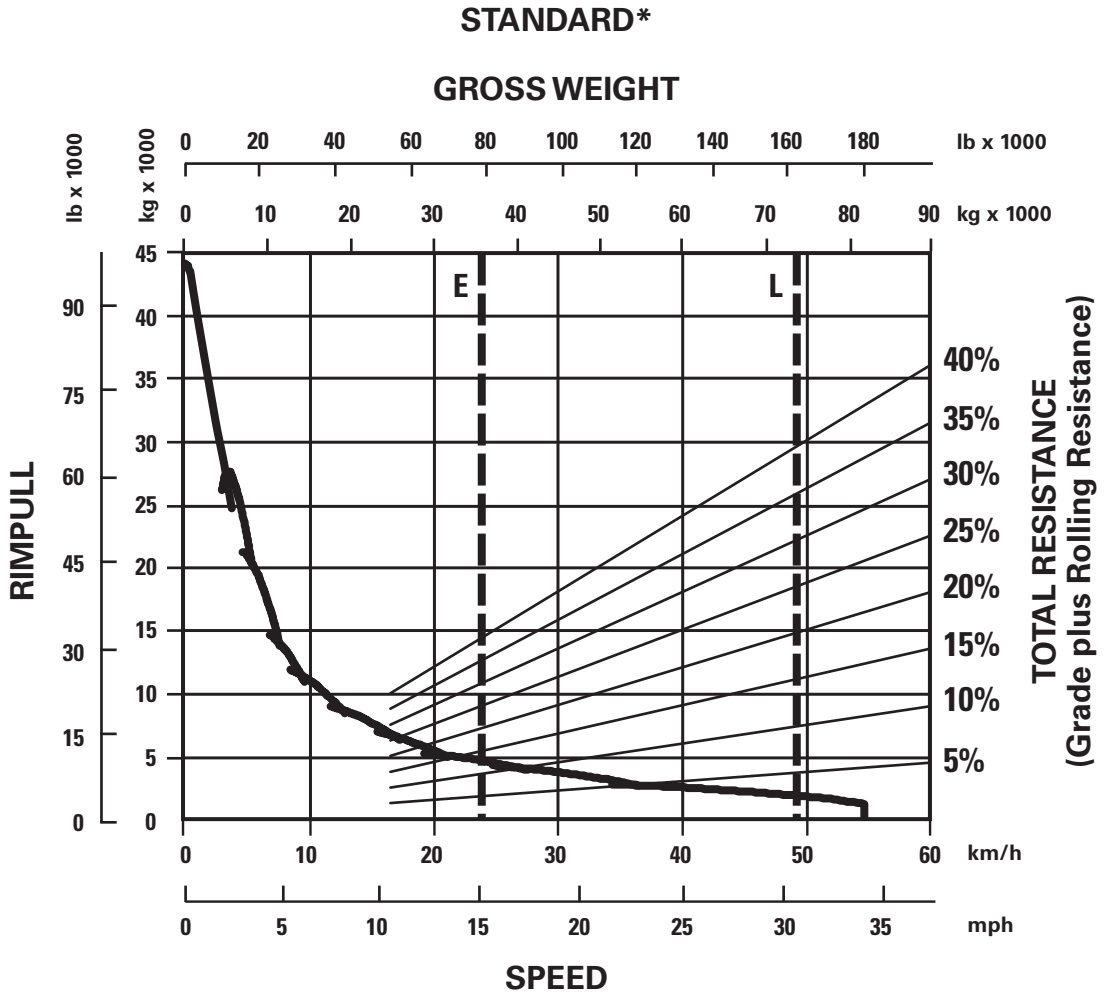

**KEY**

- E — Empty 36 000 kg (79,400 lb)
- L — Loaded 74 000 kg (163,100 lb)

\*At sea level.

# Articulated Trucks

## 740C EJ Series Brake/Retarder Performance Curve

- 29.5R25 Tires
- Tier 2/Stage II/Japan 2001 (Tier 2) equivalent

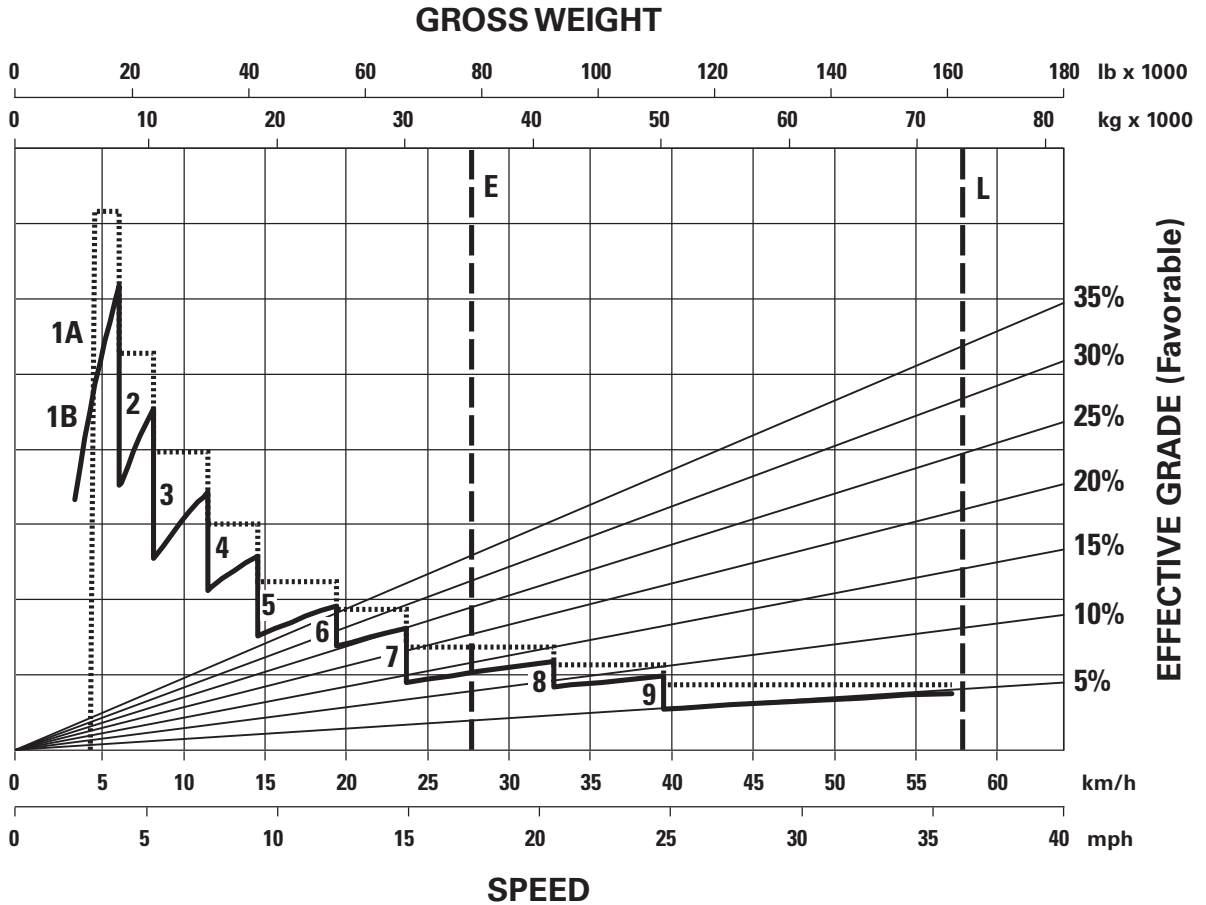

### KEY

- 1A — 1st Gear (Converter Drive)
- 1B — 1st Gear (Direct Drive)
- 2 — 2nd Gear
- 3 — 3rd Gear
- 4 — 4th Gear
- 5 — 5th Gear
- 6 — 6th Gear
- 7 — 7th Gear
- 8 — 8th Gear
- 9 — 9th Gear

### KEY

- E — Empty 35 540 kg (78,352 lb)
- L — Loaded 73 540 kg (162,128 lb)

● 29.5R25 Tires

● Tier 4 Final/Stage IV/Japan 2014 (Tier 4 Final)

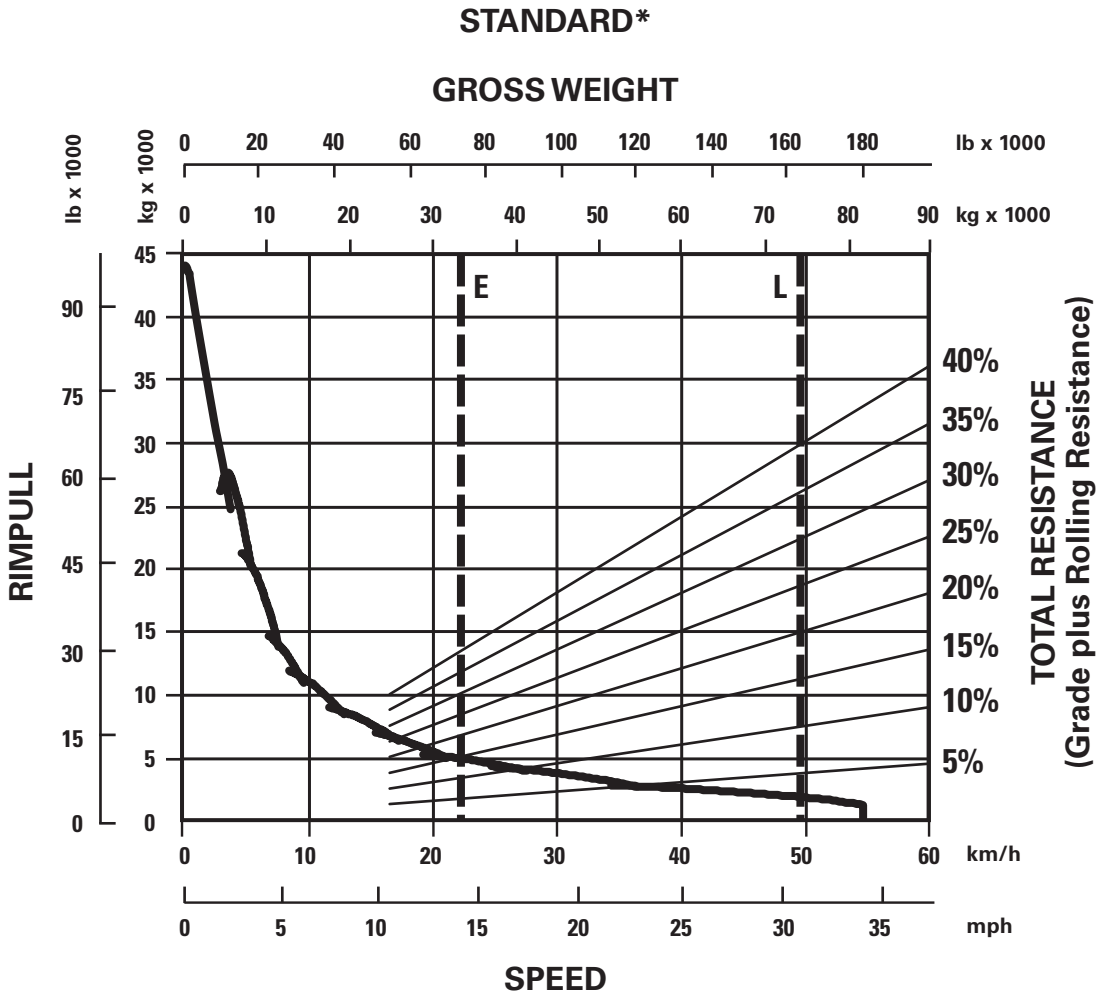

**KEY**

- E — Empty 33 600 kg (74,100 lb)
- L — Loaded 74 600 kg (164,500 lb)

\*At sea level.

# Articulated Trucks

## 745C Series Brake/Retarder Performance Curve

- 29.5R25 Tires
- Tier 4 Final/Stage IV/Japan 2014 (Tier 4 Final)

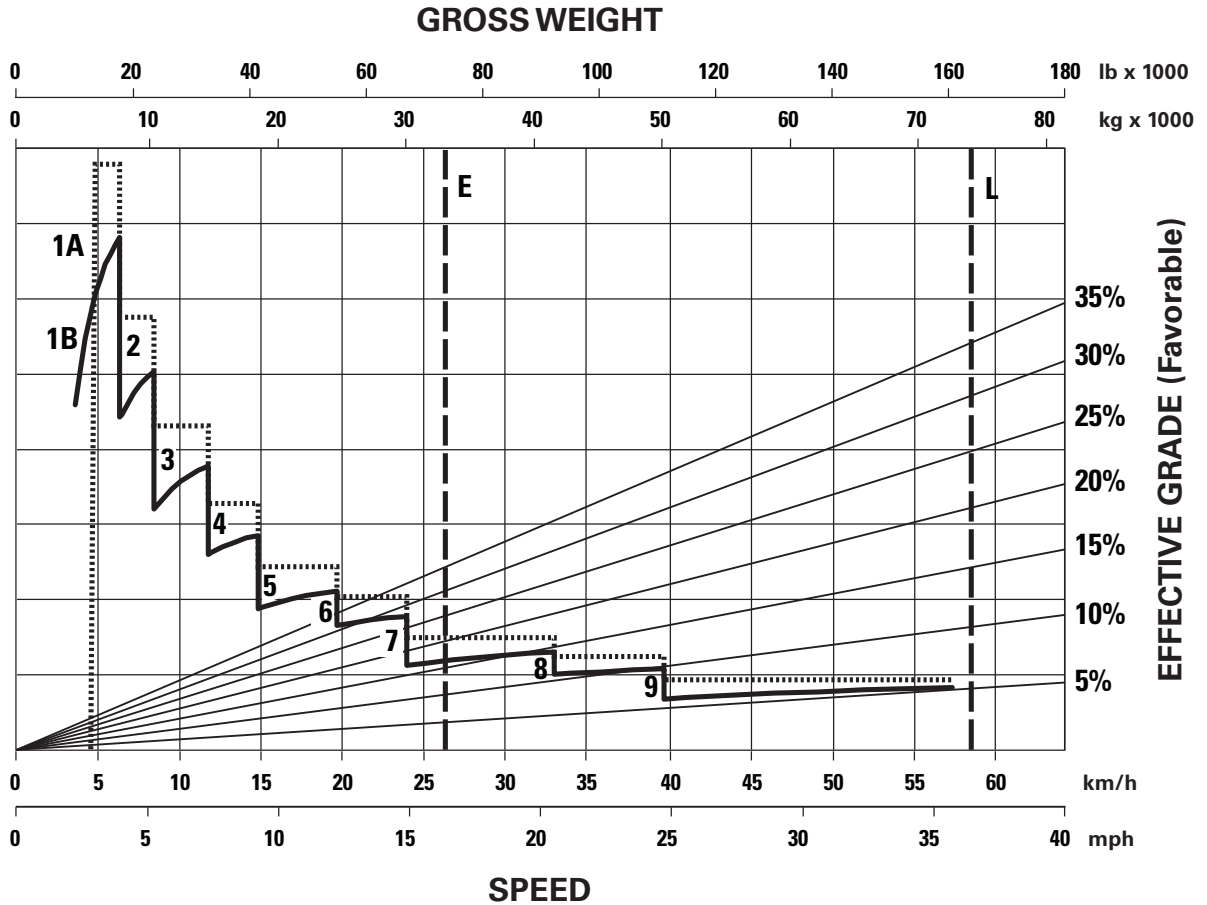

### KEY

- 1A – 1st Gear (Converter Drive)
- 1B – 1st Gear (Direct Drive)
- 2 – 2nd Gear
- 3 – 3rd Gear
- 4 – 4th Gear
- 5 – 5th Gear
- 6 – 6th Gear
- 7 – 7th Gear
- 8 – 8th Gear
- 9 – 9th Gear

### KEY

- E – Empty 33 400 kg (73,635 lb)
- L – Loaded 74 400 kg (164,024 lb)

● 29.5R25 Tires

● Tier 2/Stage II/Japan 2001 (Tier 2) equivalent

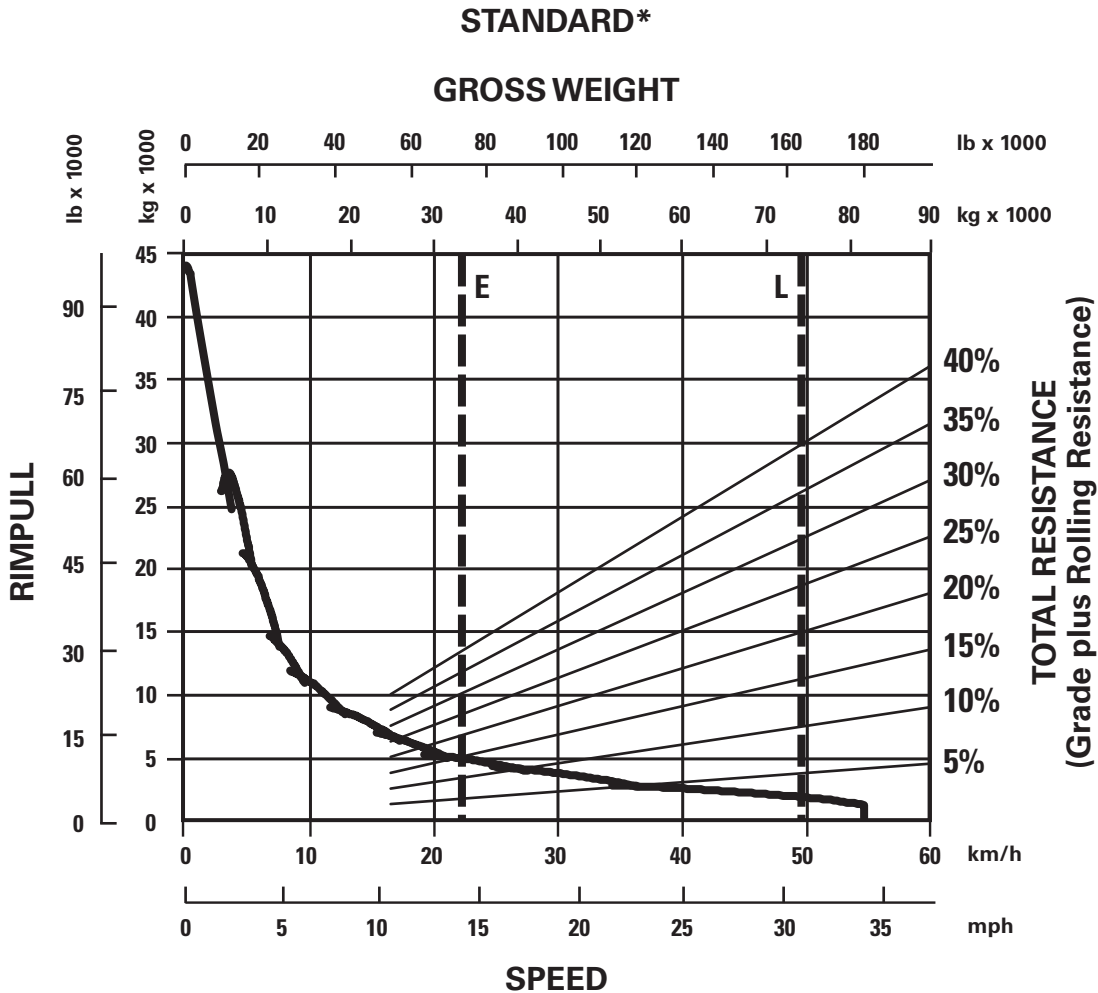

**KEY**

- E — Empty 33 600 kg (74,100 lb)
- L — Loaded 74 600 kg (164,500 lb)

\*At sea level.

# Articulated Trucks

## 745C Series Brake/Retarder Performance Curve

- 29.5R25Tires
- Tier 2/Stage II/Japan 2001 (Tier 2) equivalent

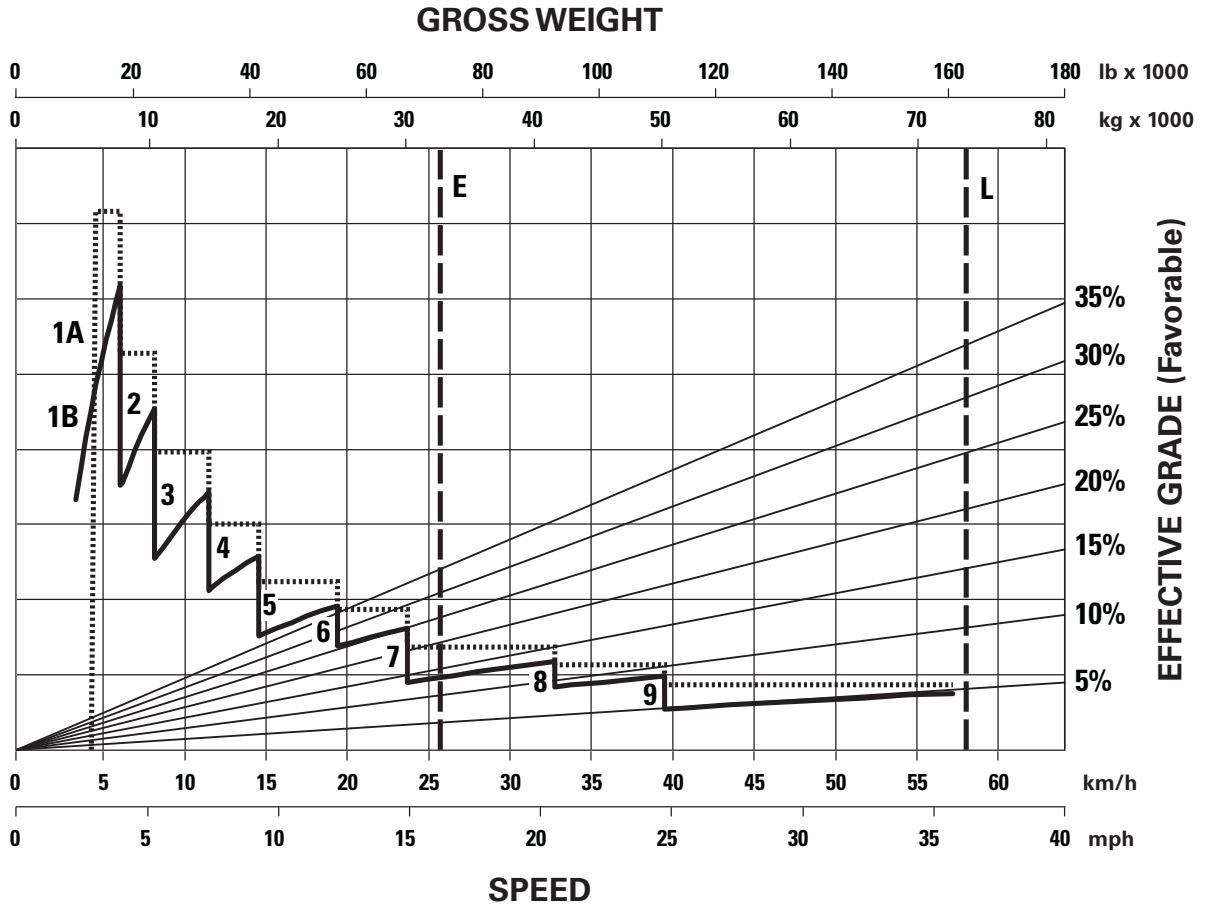

### KEY

- 1A – 1st Gear (Converter Drive)
- 1B – 1st Gear (Direct Drive)
- 2 – 2nd Gear
- 3 – 3rd Gear
- 4 – 4th Gear
- 5 – 5th Gear
- 6 – 6th Gear
- 7 – 7th Gear
- 8 – 8th Gear
- 9 – 9th Gear

### KEY

- E – Empty 32 870 kg (72,466 lb)
- L – Loaded 73 870 kg (162,855 lb)

# BACKHOE LOADERS

## CONTENTS

Features . . . . .	2-1
Specifications . . . . .	2-3
415F2/416F2:	
Performance Data . . . . .	2-7
Lift Capacities . . . . .	2-10
420F2/420F2 IT:	
Performance Data . . . . .	2-13
Lift Capacities . . . . .	2-21
422F2:	
Performance Data . . . . .	2-24
Lift Capacities . . . . .	2-26
427F2/428F2:	
Performance Data . . . . .	2-29
Lift Capacities . . . . .	2-33
430F2/430F2 IT:	
Performance Data . . . . .	2-36
Lift Capacities . . . . .	2-43
432F2:	
Performance Data . . . . .	2-46
Lift Capacities . . . . .	2-50
434F2:	
Performance Data . . . . .	2-55
Lift Capacities . . . . .	2-58
444F2:	
Performance Data . . . . .	2-61
Lift Capacities . . . . .	2-66
450F:	
Performance Data . . . . .	2-71
Lift Capacities . . . . .	2-74
Backhoe Bucket Capacities . . . . .	2-75
Work Tools . . . . .	2-77

## Features:

- **Center pivot backhoe** — 415F2, 416F2, 420F2, 430F2, 450F.
- **Side shift backhoe** — 422F2, 427F2, 428F2, 432F2, 434F2, 444F2.
- **Single-tilt loader** features a narrow loader tower and single bucket tilt cylinder for improved visibility.
- **Integrated toolcarrier (parallel lift) loader** offers maximum lift and breakout forces and parallel lift for efficient loading and material handling.
  - **Hydraulic Quick Coupler** provides versatility and allows quick connection to selected work tools for the Cat family of integrated toolcarriers.
- **Excavator-style backhoe** provides enhanced visibility even with narrow buckets, ability to reach over obstacles, and faster, easier truck loading.
  - **Backhoe Quick Coupler** offerings include a convenient “pin grabber” and versatile “pin puller” for use with D/E/F Series and competitive work tools.
- **Load-sensing hydraulic system** provides full hydraulic torque to implements at all engine speeds, low fuel consumption, smooth control and low lever efforts. An electronic torque limiter automatically optimizes hydraulics.

For product support, sales and marketing support information and business tools to help improve business functions and processes for Cat® dealers, click on the link below. For Backhoe Loaders and other Cat machines select Machines under the Product tab.

*dealer.cat.com*



- **Pilot operated backhoe controls** provide smooth, efficient operation and operator comfort. Not available on 422F2, 427F2, 428F2, 434F2. New thumb roller controllers provide ergonomic function of the extendible stick and/or auxiliary hydraulic circuits. Convenient pattern changer switch is within the cab.
- **Pilot operated stabilizer controls** are standard on 420F2, 430F2, 432F2, 444F2, 450F. Auto-up stabilizers are standard with the deluxe cab.
- **The Cat C3.4 and C4.4 ACERT™ Direct Injection Turbocharged Aftercooled engines** meet U.S. EPA Tier 4 Final/EU Stage IV/Japan 2014 (Tier 4 Final) emission standards. The efficient fuel system delivers reliable engine lug performance. Some models are powered with Cat 3054C DIT engines, which meet Tier 2/Stage II/Japan 2001 (Tier 2) equivalent emission standards.
- **XT™-3 ES hoses** combined with Cat couplings and O-ring face seal fittings provide a dry, reliable machine. The F and F2 Series backhoe circuits incorporate the XT-3 ES ToughGuard™ hoses.
- **Operator station features:** Air-suspension seat is standard on all models. Adjustable tilt steering is standard except on 415F2, 416F2, 422F2. Rear, door and side windows can be fully opened for enhanced ventilation and cab roof is extended to help keep operator dry. Four-post Rollover Protective Structure (ROPS) for increased protection. Fully featured, a Deluxe Cab option will feature pilot operated joystick controls, state-of-the-art control panels with white-faced gauges mounted in a rotating vandal cover, pilot operated stabilizer controls with automatic hold upon lifting, and additional system monitoring including service indicators for engine air cleaner, water-in-fuel, and hydraulic filter.
- **High performance backhoe linkage** offers 205° of bucket rotation with one pin position. Backhoe geometry creates more stick force than previous series, brought closer to the operator to pull spoil through trench. The 450F has a backhoe bucket rotation of 198°.
- **Diagonal Retention System (DRS)** standard on all factory installed buckets with weld-on tooth adapters, excluding the 450F. Bucket teeth are attached with diagonal pins rather than horizontal pins for easy exchange of bucket teeth. 450F buckets remain fitted with J225 size, horizontal fastener pins. All other buckets have bolt-on Uni-teeth.
- **Integrated lift eye** on backhoe linkage. Object handling installation available on 427F2, 428F2, 432F2, 434F2, 444F2 for EU countries.
- **Cat Cushion Swing** system smooths the swing function, improving the return-to-trench controllability.
- **The extendible stick** on 415F2, 416F2, 420F2, 430F2 and 450F offers object clamping while extending. Ser-rated edges secure clamped objects. Wear pad configuration eases adjustment on all four sliding surfaces. Center pivot sticks have thumb mounts.
- **The hydraulic system** uses load sensing, flow sharing valves with anti-drift characteristics. Smooth, multi-function operation with the ability to have maximum lifting and digging forces at any RPM.
- **Ride Control** available as an option on all F and F2 Series machines. The Ride-Control system smooths the ride under all job-site conditions.
- **4F/4R fully synchronized gear box** provides on-the-go shifting in all gears and on-the-go engagement of optional all wheel drive. Maximum travel speed is 40 km/h (25 mph).
- **Auto-Shift transmission** is available as an option on F2 Series and is standard on 444F2 and 450F for operator comfort and efficiency. This transmission is equipped with 6F/3R power shift gear box.
- **Lock-up torque converter** available as an option on 420F2, 430F2, 428F2, 434F2, 434F2 and 444F2 for improved efficiency.
- **Brakes** are oil immersed, multi-disc, self adjusting, and wear surface is made of Kevlar for long service life. Brakes are boosted on all models.
- **All Wheel Drive** is available as an option on all F and F2 Series machines, standard on 430F2, 434F2, 444F2 and 450F. It improves mobility and loader performance in poor traction conditions and can be engaged at any time in any operating condition. Includes 4-wheel braking effect feature.
- **Sloping, flip-open multi-access hood** allows excellent visibility to the loader working area and tilts forward for single location access to all daily service points.
- **Dry-type, radial seal air cleaner** with automatic, integrated dust ejector system provides efficient pre-separation. The two-stage air filter incorporates both air cleaner and pre-cleaner functions into a single unit mounted under the hood.

MODEL	415F2		416F2		420F2/420F2 IT	
Flywheel Power						
Gross — Tier 4 Final/Stage IV/Japan 2014 (Tier 4 Final)	55 kW	<b>74 hp</b>	70 kW	<b>94 hp</b>	74 kW	<b>100 hp</b>
Net — Tier 4 Final/Stage IV/Japan 2014 (Tier 4 Final)	51 kW	<b>68 hp</b>	66 kW	<b>89 hp</b>	70 kW	<b>94 hp</b>
Gross — Tier 3/Stage IIIA/Japan 2006 (Tier 3) equivalent	—	—	70 kW	<b>94 hp</b>	75 kW	<b>101 hp</b>
Net — Tier 3/Stage IIIA/Japan 2006 (Tier 3) equivalent	—	—	65 kW	<b>87 hp</b>	71 kW	<b>95 hp</b>
Gross — Tier 2/Stage II/Japan 2001 (Tier 2) equivalent	—	—	68 kW	<b>92 hp</b>	74 kW	<b>99 hp</b>
Net — Tier 2/Stage II/Japan 2001 (Tier 2) equivalent	—	—	65 kW	<b>87 hp</b>	71 kW	<b>95 hp</b>
Net Torque Rise at 1400 rpm						
Tier 4 Final/Stage IV/Japan 2014 (Tier 4 Final)	<b>88% (@1200 rpm)</b>		<b>56%</b>		<b>46%</b>	
Tier 3/Stage IIIA/Japan 2006 (Tier 3) equivalent	—		<b>37%</b>		<b>32%</b>	
Tier 2/Stage II/Japan 2001 (Tier 2) equivalent	—		<b>38%</b>		<b>31%</b>	
Peak Torque at 1400 rpm						
Tier 4 Final/Stage IV/Japan 2014 (Tier 4 Final)	416 N·m	<b>307 lbf-ft</b>	439 N·m	<b>324 lbf-ft</b>	438 N·m	<b>323 lbf-ft</b>
Tier 3/Stage IIIA/Japan 2006 (Tier 3) equivalent	—		383 N·m	<b>282 lbf-ft</b>	398 N·m	<b>294 lbf-ft</b>
Tier 2/Stage II/Japan 2001 (Tier 2) equivalent	—		384 N·m	<b>283 lbf-ft</b>	397 N·m	<b>293 lbf-ft</b>
Operating Weight	7171 kg	<b>15,809 lb</b>	7487 kg	<b>16,506 lb</b>	7726 kg	<b>17,033 lb</b>
Engine Model	<b>C3.4</b>		<b>C4.4 ACERT 3054C</b>		<b>C4.4 ACERT 3054C</b>	
Rated Engine RPM	<b>2200</b>		<b>2200</b>		<b>2200</b>	
No. of Cylinders	<b>4</b>		<b>4</b>		<b>4</b>	
Bore	99 mm	<b>3.90 in</b>	105 mm	<b>4.13 in</b>	105 mm	<b>4.13 in</b>
Stroke	110 mm	<b>4.33 in</b>	127 mm	<b>5.00 in</b>	127 mm	<b>5.00 in</b>
Displacement	3.4 L	<b>207 in<sup>3</sup></b>	4.4 L	<b>268 in<sup>3</sup></b>	4.4 L	<b>268 in<sup>3</sup></b>
Speeds (Manual)	km/h	<b>mph</b>	km/h	<b>mph</b>	km/h	<b>mph</b>
1st	5	<b>3</b>	5	<b>3</b>	5	<b>3</b>
2nd	9	<b>6</b>	9	<b>6</b>	9	<b>6</b>
3rd	20	<b>13</b>	20	<b>13</b>	21	<b>13</b>
4th	36	<b>23</b>	36	<b>23</b>	38	<b>24</b>
Speeds (Auto-Shift)						
1st	—	—	—	—	6	<b>4</b>
2nd	—	—	—	—	9	<b>6</b>
3rd	—	—	—	—	12	<b>7</b>
4th	—	—	—	—	19	<b>12</b>
5th	—	—	—	—	23	<b>14</b>
5th LUC (if equipped)	—	—	—	—	25	<b>15</b>
6th	—	—	—	—	40	<b>25</b>
6th LUC (if equipped)	—	—	—	—	40	<b>25</b>
Turning Circle, Wall to Wall	11.0 m	<b>36'0"</b>	11.0 m	<b>36'0"</b>	11.0 m	<b>36'0"</b>
Tires						
2WD Bias Front	<b>12-16.5 10 PR F-3</b>		<b>12-16.5 10 PR F-3</b>		<b>12-16.5 10 PR F-3</b>	
2WD Bias Rear	<b>19.5L-24 12 PR R-4</b>		<b>19.5L-24 12 PR R-4</b>		<b>19.5L-24 12 PR R-4</b>	
AWD Bias Front	<b>12.5/80-18 12 PR I-3</b>		<b>12.5/80-18 12 PR I-3</b>		<b>12.5/80-18 12 PR I-3</b>	
AWD Bias Rear	<b>19.5L-24 12 PR R-4</b>		<b>19.5L-24 12 PR R-4</b>		<b>19.5L-24 12 PR R-4</b>	
AWD Bias Front, Flotation	<b>12.5/80-18 12 PR I-3</b>		<b>12.5/80-18 12 PR I-3</b>		<b>12.5/80-18 12 PR I-3</b>	
AWD Bias Rear, Flotation	<b>21L-24 16 PR R-4</b>		<b>21L-24 16 PR R-4</b>		<b>21L-24 16 PR R-4</b>	
AWD Radial Front	<b>340/80R18</b>		<b>340/80R18</b>		<b>340/80R18</b>	
AWD Radial Rear	<b>500/70R24</b>		<b>500/70R24</b>		<b>500/70R24</b>	
AWD Combination Front	<b>340/80R18</b>		<b>340/80R18</b>		<b>340/80R18</b>	
AWD Combination Rear	<b>19.5L-24 12 PR R-4</b>		<b>19.5L-24 12 PR R-4</b>		<b>19.5L-24 12 PR R-4</b>	
Hydraulic System, closed center	<b>Load Sensing, Flow Sharing</b>		<b>Load Sensing, Flow Sharing</b>		<b>Load Sensing, Flow Sharing</b>	
Pump Capacity	125 L/min @ 2200 rpm @ 23 000 kPa	<b>33 gpm @ 2200 rpm @ 3336 psi</b>	125 L/min @ 2200 rpm @ 23 000 kPa	<b>33 gpm @ 2200 rpm @ 3336 psi</b>	150 L/min @ 2200 rpm @ 25 000 kPa	<b>40 gpm @ 2200 rpm @ 3626 psi</b>
Fuel Tank Capacity	160 L	<b>42 U.S. gal</b>	160 L	<b>42 U.S. gal</b>	160 L	<b>42 U.S. gal</b>

MODEL	422F2*		427F2		428F2*	
Flywheel Power						
Gross — Tier 4 Final/Stage IV/Japan 2014 (Tier 4 Final)	—		55 kW	<b>74 hp</b>	70 kW	<b>94 hp</b>
Net — Tier 4 Final/Stage IV/Japan 2014 (Tier 4 Final)	—		51 kW	<b>68 hp</b>	66 kW	<b>88 hp</b>
Gross — Tier 3/Stage IIIA/Japan 2006 (Tier 3) equivalent	—		—		70/75 kW	<b>94/100 hp</b>
Net — Tier 3/Stage IIIA/Japan 2006 (Tier 3) equivalent	—		—		65/70 kW	<b>87/94 hp</b>
Gross — Tier 2/Stage II/Japan 2001 (Tier 2) equivalent	56/68 kW	<b>76/92 hp</b>	—		68/74 kW	<b>92/100 hp</b>
Net — Tier 2/Stage II/Japan 2001 (Tier 2) equivalent	53/65 kW	<b>71/87 hp</b>	—		65/71 kW	<b>87/95 hp</b>
Net Torque Rise at 1400 rpm						
Tier 4 Final/Stage IV/Japan 2014 (Tier 4 Final)	—		<b>88% (@1200 rpm)</b>		<b>56%</b>	
Tier 3/Stage IIIA/Japan 2006 (Tier 3) equivalent	—		—		<b>37/32%</b>	
Tier 2/Stage II/Japan 2001 (Tier 2) equivalent	<b>27/38%</b>		—		<b>38/31%</b>	
Peak Torque at 1400 rpm						
Tier 4 Final/Stage IV/Japan 2014 (Tier 4 Final)	—		416 N·m	<b>307 lbf-ft</b>	439 N·m	<b>324 lbf-ft</b>
Tier 3/Stage IIIA/Japan 2006 (Tier 3) equivalent	—		—		383/398 N·m	<b>282/294 lbf-ft</b>
Tier 2/Stage II/Japan 2001 (Tier 2) equivalent	288/384 N·m	<b>212/283 lbf-ft</b>	—		384/397 N·m	<b>283/293 lbf-ft</b>
Operating Weight	7529 kg	<b>16,601 lb</b>	8108 kg	<b>17,878 lb</b>	8425 kg	<b>18,577 lb</b>
Engine Model	<b>3054C DINA</b>		<b>C3.4</b>		<b>C4.4 ACERT</b>	
	<b>3054C</b>				<b>3054C</b>	
Rated Engine RPM	<b>2200</b>		<b>2200</b>		<b>2200</b>	
No. of Cylinders	<b>4</b>		<b>4</b>		<b>4</b>	
Bore	105 mm	<b>4.13 in</b>	99 mm	<b>3.90 in</b>	105 mm	<b>4.13 in</b>
Stroke	127 mm	<b>5.00 in</b>	110 mm	<b>4.33 in</b>	127 mm	<b>5.00 in</b>
Displacement	4.4 L	<b>268 in<sup>3</sup></b>	3.4 L	<b>207 in<sup>3</sup></b>	4.4 L	<b>268 in<sup>3</sup></b>
Speeds (Manual)	km/h	<b>mph</b>	km/h	<b>mph</b>	km/h	<b>mph</b>
1st	6	<b>3</b>	6	<b>4</b>	6	<b>4</b>
2nd	9	<b>6</b>	9	<b>6</b>	9	<b>6</b>
3rd	21	<b>13</b>	21	<b>13</b>	21	<b>13</b>
4th	37	<b>23</b>	37	<b>23</b>	37	<b>23</b>
Speeds (Auto-Shift)						
1st	—	—	6	<b>4</b>	6	<b>4</b>
2nd	—	—	10	<b>6</b>	10	<b>6</b>
3rd	—	—	12	<b>8</b>	12	<b>8</b>
4th	—	—	20	<b>12</b>	20	<b>12</b>
5th	—	—	24	<b>15</b>	24	<b>15</b>
5th LUC (if equipped)	—	—	25	<b>16</b>	25	<b>16</b>
6th	—	—	40	<b>25</b>	40	<b>25</b>
6th LUC (if equipped)	—	—	40	<b>25</b>	40	<b>25</b>
Turning Circle, Wall to Wall	11.0 m	<b>36'0"</b>	11.0 m	<b>36'0"</b>	11.0 m	<b>36'0"</b>
Tires						
2WD Bias Front	<b>11-16 12 PR F-3</b>		—		—	
2WD Bias Rear	<b>16.9-28 12 PR R-4</b>		—		—	
AWD Bias Front	<b>12.5/80-18 12 PR I-3</b>		<b>12.5/80-18 10 PR I-3</b>		<b>12.5/80-18 10 PR I-3</b>	
AWD Bias Rear	<b>16.9-28 12 PR R-4</b>		<b>16.9-28 12 PR R4</b>		<b>16.9-28 12 PR R4</b>	
AWD Radial Front	<b>340/80R18</b>		<b>340/80R18</b>		<b>340/80R18</b>	
AWD Radial Rear	<b>440/80R28</b>		<b>440/80R28</b>		<b>440/80R28</b>	
Hydraulic System, closed center	<b>Load Sensing, Flow Sharing</b>		<b>Load Sensing, Flow Sharing</b>		<b>Load Sensing, Flow Sharing</b>	
Pump Capacity	125 L/min @ 2200 rpm @ 23 000 kPa	<b>33 gpm @ 2200 rpm @ 3336 psi</b>	150 L/min @ 2200 rpm @ 25 000 kPa	<b>40 gpm @ 2200 rpm @ 3626 psi</b>	150 L/min @ 2200 rpm @ 25 000 kPa	<b>40 gpm @ 2200 rpm @ 3626 psi</b>
Fuel Tank Capacity	160 L	<b>42 U.S. gal</b>	160 L	<b>42 U.S. gal</b>	160 L	<b>42 U.S. gal</b>

\*Multiple engine power ratings available.

MODEL	430F2/430F2 IT		432F2*		434F2*	
Flywheel Power						
Gross — Tier 4 Final/Stage IV/Japan 2014 (Tier 4 Final)	86 kW	<b>115 hp</b>	74/82 kW	<b>100/110 hp</b>	74 kW	<b>100 hp</b>
Net — Tier 4 Final/Stage IV/Japan 2014 (Tier 4 Final)	82 kW	<b>109 hp</b>	70/78 kW	<b>94/104 hp</b>	70 kW	<b>94 hp</b>
Gross — Tier 3/Stage IIIA/Japan 2006 (Tier 3) equivalent	75 kW	<b>100 hp</b>	75 kW	<b>101 hp</b>	75 kW	<b>100 hp</b>
Net — Tier 3/Stage IIIA/Japan 2006 (Tier 3) equivalent	70 kW	<b>94 hp</b>	71 kW	<b>95 hp</b>	70 kW	<b>94 hp</b>
Gross — Tier 2/Stage II/Japan 2001 (Tier 2) equivalent	74 kW	<b>100 hp</b>	74 kW	<b>100 hp</b>	68/74 kW	<b>92/100 hp</b>
Net — Tier 2/Stage II/Japan 2001 (Tier 2) equivalent	71 kW	<b>95 hp</b>	71 kW	<b>95 hp</b>	65/71 kW	<b>87/95 hp</b>
Net Torque Rise at 1400 rpm						
Tier 4 Final/Stage IV/Japan 2014 (Tier 4 Final)		<b>39%</b>		<b>46/32%</b>		<b>46%</b>
Tier 3/Stage IIIA/Japan 2006 (Tier 3) equivalent		<b>32%</b>		<b>32%</b>		<b>32%</b>
Tier 2/Stage II/Japan 2001 (Tier 2) equivalent		<b>31%</b>		<b>31%</b>		<b>38/31%</b>
Peak Torque at 1400 rpm						
Tier 4 Final/Stage IV/Japan 2014 (Tier 4 Final)	488 N·m	<b>360 lbf-ft</b>	438/439 N·m	<b>323/324 lbf-ft</b>	438 N·m	<b>323 lbf-ft</b>
Tier 3/Stage IIIA/Japan 2006 (Tier 3) equivalent	398 N·m	<b>294 lbf-ft</b>	399 N·m	<b>294 lbf-ft</b>	398 N·m	<b>294 lbf-ft</b>
Tier 2/Stage II/Japan 2001 (Tier 2) equivalent	397 N·m	<b>293 lbf-ft</b>	397 N·m	<b>293 lbf-ft</b>	384/397 N·m	<b>283/293 lbf-ft</b>
Operating Weight	8330 kg	<b>18,364 lb</b>	8479 kg	<b>18,696 lb</b>	9257 kg	<b>20,408 lb</b>
Engine Model	<b>C4.4 ACERT 3054C</b>		<b>C4.4 ACERT 3054C</b>		<b>C4.4 ACERT 3054C</b>	
Rated Engine RPM	<b>2200</b>		<b>2200</b>		<b>2200</b>	
No. of Cylinders	<b>4</b>		<b>4</b>		<b>4</b>	
Bore	105 mm	<b>4.13 in</b>	105 mm	<b>4.13 in</b>	105 mm	<b>4.13 in</b>
Stroke	127 mm	<b>5.00 in</b>	127 mm	<b>5.00 in</b>	127 mm	<b>5.00 in</b>
Displacement	4.4 L	<b>268 in<sup>3</sup></b>	4.4 L	<b>268 in<sup>3</sup></b>	4.4 L	<b>268 in<sup>3</sup></b>
Speeds (Manual)	km/h	<b>mph</b>	km/h	<b>mph</b>	km/h	<b>mph</b>
1st	5	<b>3</b>	6	<b>4</b>	6	<b>3</b>
2nd	9	<b>6</b>	9	<b>6</b>	9	<b>6</b>
3rd	21	<b>13</b>	22	<b>13</b>	21	<b>13</b>
4th	38	<b>24</b>	40	<b>25</b>	36	<b>22</b>
Speeds (Auto-Shift)						
1st	6	<b>4</b>	6	<b>4</b>	6	<b>4</b>
2nd	9	<b>6</b>	10	<b>6</b>	10	<b>6</b>
3rd	12	<b>8</b>	13	<b>8</b>	12	<b>8</b>
4th	19	<b>12</b>	20	<b>12</b>	20	<b>12</b>
5th	23	<b>14</b>	24	<b>15</b>	24	<b>15</b>
5th LUC (if equipped)	25	<b>15</b>	26	<b>16</b>	26	<b>16</b>
6th	40	<b>25</b>	40	<b>25</b>	40	<b>25</b>
6th LUC (if equipped)	40	<b>25</b>	40	<b>25</b>	40	<b>25</b>
Turning Circle, Wall to Wall	11.0 m	<b>36'0"</b>	11.0 m	<b>36'0"</b>	12.6 m	<b>41'4"</b>
Tires						
AWD Bias Front	<b>12.5/80-18 12 PR I-3</b>		<b>12.5/80-18 10 PR I-3</b>		—	
AWD Bias Rear	<b>19.5L-24 12 PR R4</b>		<b>16.9-28 12 PR R4</b>		—	
AWD Bias Front, Flotation	<b>12.5/80-18 12 PR I-3</b>		—		—	
AWD Bias Rear, Flotation	<b>21L-24 16 PR</b>		—		—	
AWD Radial Front	<b>340/80R18</b>		<b>340/80R18</b>		<b>440/80R24</b>	
AWD Radial Rear	<b>500/70R24</b>		<b>440/80R28</b>		<b>440/80R24</b>	
AWD Combination Front	<b>340/80R18 XMCL</b>		—		—	
AWD Combination Rear	<b>19.5L-24 12 PR R4</b>		—		—	
Hydraulic System, closed center	<b>Load Sensing, Flow Sharing</b>		<b>Load Sensing, Flow Sharing</b>		<b>Load Sensing, Flow Sharing</b>	
Pump Capacity	150 L/min @ 2200 rpm @ 25 000 kPa	<b>40 gpm @ 2200 rpm @ 3626 psi</b>	150 L/min @ 2200 rpm @ 25 000 kPa	<b>40 gpm @ 2200 rpm @ 3626 psi</b>	150 L/min @ 2200 rpm @ 25 000 kPa	<b>40 gpm @ 2200 rpm @ 3626 psi</b>
Fuel Tank Capacity	160 L	<b>42 U.S. gal</b>	160 L	<b>42 U.S. gal</b>	160 L	<b>42 U.S. gal</b>

\*Multiple engine power ratings available.

MODEL	444F2*		450F	
Flywheel Power				
Gross — Tier 4 Final/Stage IV/Japan 2014 (Tier 4 Final)	74/82 kW	<b>100/110 hp</b>	106 kW**	<b>142 hp**</b>
Net — Tier 4 Final/Stage IV/Japan 2014 (Tier 4 Final)	70/78 kW	<b>94/104 hp</b>	96 kW**	<b>128 hp**</b>
Gross — Tier 3/Stage IIIA/Japan 2006 (Tier 3) equivalent	75 kW	<b>100 hp</b>	—	—
Net — Tier 3/Stage IIIA/Japan 2006 (Tier 3) equivalent	70 kW	<b>94 hp</b>	—	—
Gross — Tier 2/Stage II/Japan 2001 (Tier 2) equivalent	74 kW	<b>100 hp</b>	—	—
Net — Tier 2/Stage II/Japan 2001 (Tier 2) equivalent	71 kW	<b>95 hp</b>	—	—
Net Torque Rise at 1400 rpm				
Tier 4 Final/Stage IV/Japan 2014 (Tier 4 Final)		<b>46/32%</b>		<b>31%**</b>
Tier 3/Stage IIIA/Japan 2006 (Tier 3) equivalent		<b>32%</b>		—
Tier 2/Stage II/Japan 2001 (Tier 2) equivalent		<b>31%</b>		—
Peak Torque at 1400 rpm				
Tier 4 Final/Stage IV/Japan 2014 (Tier 4 Final)	438/439 N·m	<b>323/324 lbf-ft</b>	542 N·m**	<b>413 lbf-ft**</b>
Tier 3/Stage IIIA/Japan 2006 (Tier 3) equivalent	398 N·m	<b>294 lbf-ft</b>	—	—
Tier 2/Stage II/Japan 2001 (Tier 2) equivalent	397 N·m	<b>293 lbf-ft</b>	—	—
Operating Weight	9606 kg	<b>21,178 lb</b>	11 283 kg	<b>24,875 lb</b>
Engine Model	<b>C4.4 ACERT 3054C</b>		<b>C4.4 ACERT**</b>	
Rated Engine RPM	<b>2200</b>		<b>2200</b>	
No. of Cylinders	<b>4</b>		<b>4</b>	
Bore	105 mm	<b>4.13 in</b>	105 mm	<b>4.13 in</b>
Stroke	127 mm	<b>5.00 in</b>	127 mm	<b>5.00 in</b>
Displacement	4.4 L	<b>268 in<sup>3</sup></b>	4.4 L	<b>268 in<sup>3</sup></b>
Speeds (Auto-Shift)	km/h	<b>mph</b>	km/h	<b>mph</b>
1st	6	<b>4</b>	6	<b>4</b>
2nd	10	<b>6</b>	10	<b>6</b>
3rd	12	<b>8</b>	20	<b>12</b>
4th	20	<b>12</b>	27	<b>17</b>
5th	24	<b>15</b>	40	<b>25</b>
5th LUC (if equipped)	25	<b>16</b>	—	—
6th	40	<b>25</b>	—	—
6th LUC (if equipped)	40	<b>25</b>	—	—
Turning Circle, Wall to Wall	12.6 m	<b>41'4"</b>	11.2 m	<b>36'8"</b>
Tires				
AWD Bias Front	—	—	<b>15-19.5 12 PR</b>	—
AWD Bias Rear	—	—	<b>21L-24 18 PR R-4</b>	—
AWD Radial Front	<b>440/80R28</b>	—	—	—
AWD Radial Rear	<b>440/80R28</b>	—	—	—
Hydraulic System, closed center	<b>Load Sensing, Flow Sharing</b>		<b>Load Sensing, Flow Sharing</b>	
Pump Capacity	150 L/min @ 2200 rpm @ 25 000 kPa	<b>40 gpm @ 2200 rpm @ 3626 psi</b>	185 L/min @ 2200 rpm @ 25 000 kPa	<b>48 gpm @ 2200 rpm @ 3626 psi</b>
Fuel Tank Capacity	160 L	<b>42 U.S. gal</b>	160 L	<b>42 U.S. gal</b>

\*Multiple engine power ratings available.  
 \*\*The 450F engine meets U.S. EPA Tier 4 Interim/EU Stage IIIB emission standards only.

Single-Tilt Loader

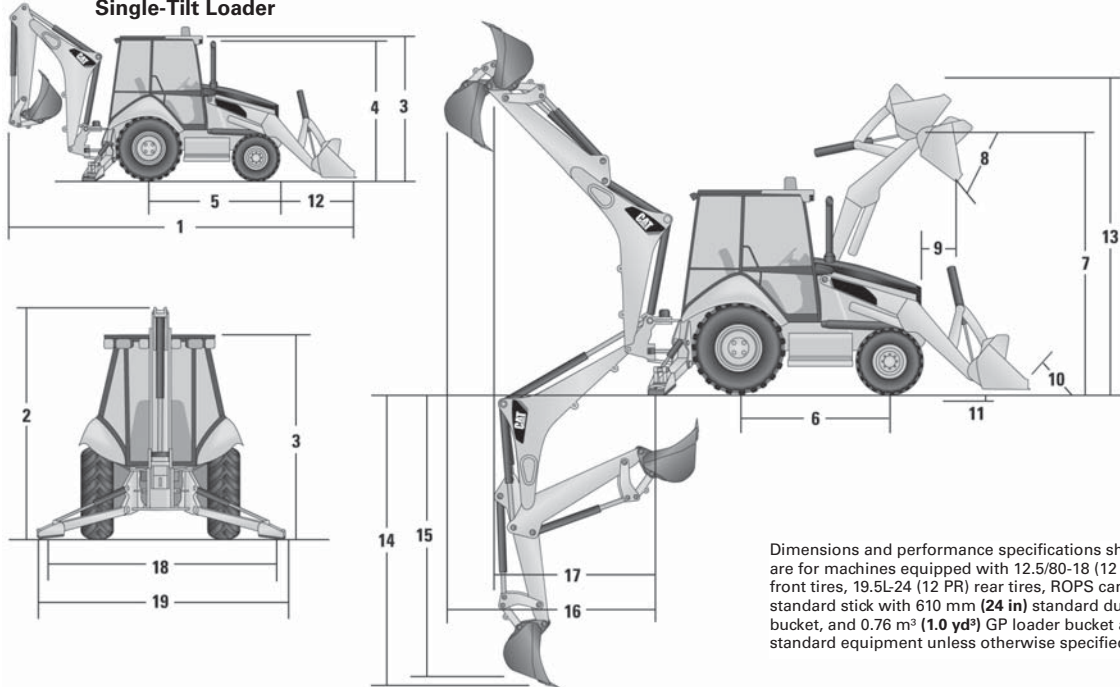

Dimensions and performance specifications shown are for machines equipped with 12.5/80-18 (12 PR) front tires, 19.5L-24 (12 PR) rear tires, ROPS canopy, standard stick with 610 mm (24 in) standard duty bucket, and 0.76 m<sup>3</sup> (1.0 yd<sup>3</sup>) GP loader bucket and standard equipment unless otherwise specified.

MACHINE DIMENSIONS	Single-Tilt Loader							
	General Purpose 0.76 m <sup>3</sup> (1.0 yd <sup>3</sup> )		General Purpose 0.96 m <sup>3</sup> (1.25 yd <sup>3</sup> )		Multi Purpose 1.0 m <sup>3</sup> (1.31 yd <sup>3</sup> )		Multi Purpose with Forks 1.0 m <sup>3</sup> (1.31 yd <sup>3</sup> )	
1) Overall transport length	7085 mm	23'3"	7168 mm	23'6"	7132 mm	23'5"	7132 mm	23'5"
Overall length	7027 mm	23'1"	7140 mm	23'5"	7057 mm	23'2"	7057 mm	23'2"
2) Overall transport height S-stick	3577 mm	11'9"	3577 mm	11'9"	3577 mm	11'9"	3577 mm	11'9"
Overall transport height E-stick	3631 mm	11'11"	3631 mm	11'11"	3631 mm	11'11"	3631 mm	11'11"
Overall width	2322 mm	7'7"	2322 mm	7'7"	2322 mm	7'7"	2322 mm	7'7"
3) Height to top of cab/canopy	2819 mm	9'3"	2819 mm	9'3"	2819 mm	9'3"	2819 mm	9'3"
4) Height to top of exhaust stack	2744 mm	9'0"	2744 mm	9'0"	2744 mm	9'0"	2744 mm	9'0"
Ground clearance (LH step)	294 mm	1'0"	294 mm	1'0"	294 mm	1'0"	294 mm	1'0"
Ground clearance (AWD guard)	294 mm	1'0"	294 mm	1'0"	294 mm	1'0"	294 mm	1'0"
Ground clearance (485 kg/ 1170 lb counterweight)	274 mm	11"	274 mm	11"	274 mm	11"	274 mm	11"
5) Rear axle centerline to front grill	2705 mm	8'10"	2705 mm	8'10"	2705 mm	8'10"	2705 mm	8'10"
Front wheel tread gauge	1895 mm	6'3"	1895 mm	6'3"	1895 mm	6'3"	1895 mm	6'3"
Rear wheel tread gauge	1714 mm	5'7"	1714 mm	5'7"	1714 mm	5'7"	1714 mm	5'7"
6) Wheelbase (2WD/AWD)	2200 mm	7'3"	2200 mm	7'3"	2200 mm	7'3"	2200 mm	7'3"

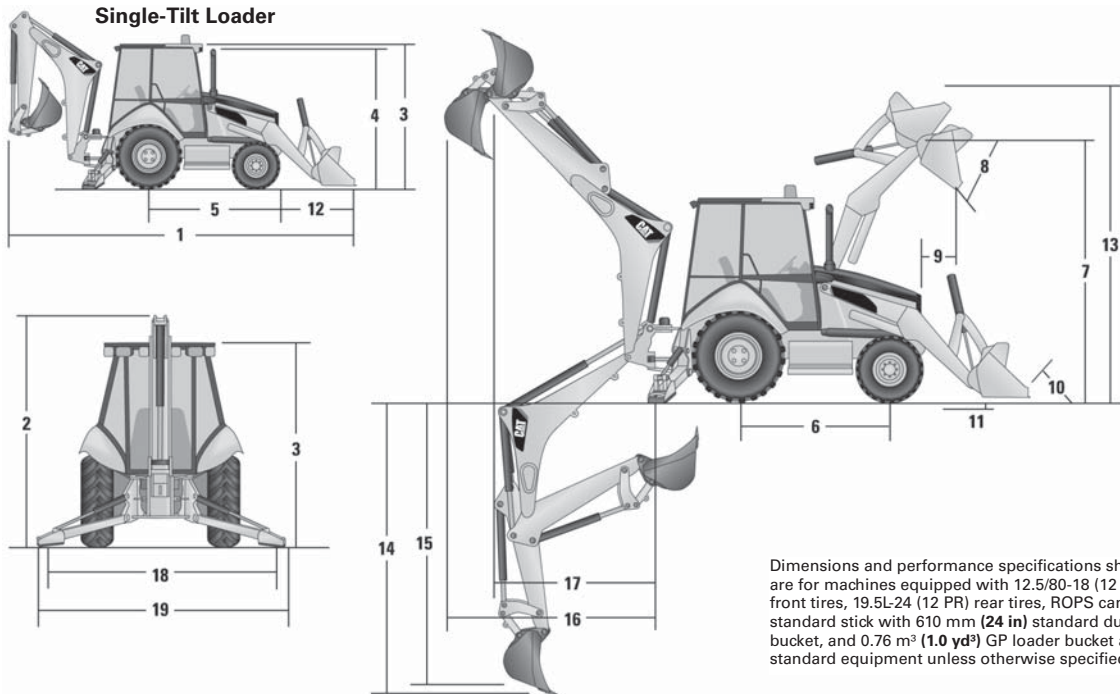

Dimensions and performance specifications shown are for machines equipped with 12.5/80-18 (12 PR) front tires, 19.5L-24 (12 PR) rear tires, ROPS canopy, standard stick with 610 mm (24 in) standard duty bucket, and 0.76 m<sup>3</sup> (1.0 yd<sup>3</sup>) GP loader bucket and standard equipment unless otherwise specified.

LOADER BUCKET DIMENSIONS AND PERFORMANCE	Single-Tilt Loader							
	General Purpose 0.76 m <sup>3</sup> (1.0 yd <sup>3</sup> )		General Purpose 0.96 m <sup>3</sup> (1.25 yd <sup>3</sup> )		Multi Purpose 1.0 m <sup>3</sup> (1.31 yd <sup>3</sup> )		Multi Purpose with Forks 1.0 m <sup>3</sup> (1.31 yd <sup>3</sup> )	
Capacity (SAE) rated	0.76 m <sup>3</sup>	<b>1.0 yd<sup>3</sup></b>	0.96 m <sup>3</sup>	<b>1.25 yd<sup>3</sup></b>	1.0 m <sup>3</sup>	<b>1.31 yd<sup>3</sup></b>	1.0 m <sup>3</sup>	<b>1.31 yd<sup>3</sup></b>
Width	2262 mm	<b>7'5"</b>	2262 mm	<b>7'5"</b>	2279 mm	<b>7'6"</b>	2279 mm	<b>7'6"</b>
Lift capacity at maximum height	3062 kg	<b>6751 lb</b>	2964 kg	<b>6535 lb</b>	2771 kg	<b>6108 lb</b>	2656 kg	<b>5855 lb</b>
Lift breakout force	47.9 kN	<b>10,772 lbf</b>	45.3 kN	<b>10,189 lbf</b>	44.4 kN	<b>9979 lbf</b>	42.9 kN	<b>9645 lbf</b>
Tilt breakout force	54.6 kN	<b>12,281 lbf</b>	46.0 kN	<b>10,339 lbf</b>	52.7 kN	<b>11,841 lbf</b>	51.8 kN	<b>11,636 lbf</b>
7) Maximum hinge pin height	3474 mm	<b>11'5"</b>	3474 mm	<b>11'5"</b>	3474 mm	<b>11'5"</b>	3474 mm	<b>11'5"</b>
8) Dump angle at full height		<b>44°</b>		<b>44°</b>		<b>44°</b>		<b>44°</b>
Dump height at maximum angle	2824 mm	<b>9'3"</b>	2746 mm	<b>9'0"</b>	2798 mm	<b>9'2"</b>	2798 mm	<b>9'2"</b>
9) Dump reach at maximum angle	727 mm	<b>2'5"</b>	808 mm	<b>2'8"</b>	716 mm	<b>2'4"</b>	716 mm	<b>2'4"</b>
10) Maximum bucket rollback at ground level		<b>37°</b>		<b>37°</b>		<b>38°</b>		<b>38°</b>
11) Digging depth	83 mm	<b>3"</b>	83 mm	<b>3"</b>	110 mm	<b>4"</b>	110 mm	<b>4"</b>
Maximum grading angle		<b>116°</b>		<b>112°</b>		<b>116°</b>		<b>116°</b>
Width of dozer cutting edge		<b>N/A</b>		<b>N/A</b>	2262 mm	<b>7'5"</b>	2262 mm	<b>7'5"</b>
12) Grill to bucket cutting edge, carry position	1404 mm	<b>4'7"</b>	1487 mm	<b>4'11"</b>	1451 mm	<b>4'9"</b>	1451 mm	<b>4'9"</b>
13) Maximum operating height	4206 mm	<b>13'10"</b>	4355 mm	<b>14'3"</b>	4404 mm	<b>14'5"</b>	4878 mm	<b>16'0"</b>
Jaw opening maximum		<b>N/A</b>		<b>N/A</b>	790 mm	<b>2'7"</b>	790 mm	<b>2'7"</b>
Bucket jaw clamping force		<b>N/A</b>		<b>N/A</b>	50.6 kN	<b>11,375 lbf</b>	50.6 kN	<b>11,375 lbf</b>
Weight (does not include teeth or forks)	384 kg	<b>847 lb</b>	451 kg	<b>994 lb</b>	745 kg	<b>1642 lb</b>	915 kg	<b>2017 lb</b>

Single-Tilt Loader

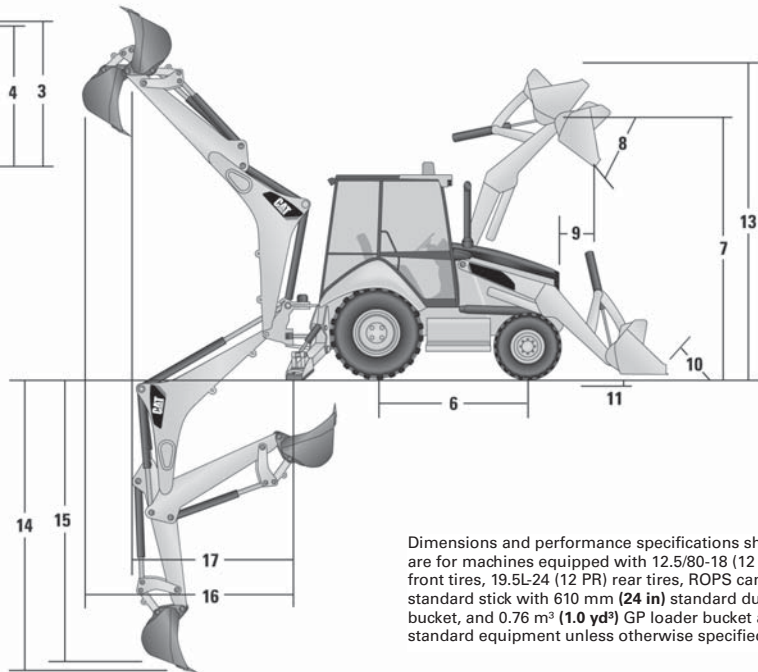
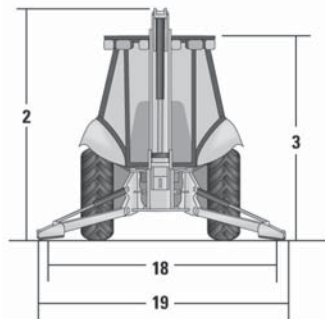
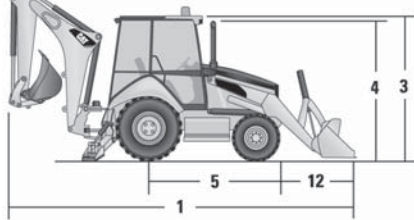

Dimensions and performance specifications shown are for machines equipped with 12.5/80-18 (12 PR) front tires, 19.5L-24 (12 PR) rear tires, ROPS canopy, standard stick with 610 mm (24 in) standard duty bucket, and 0.76 m<sup>3</sup> (1.0 yd<sup>3</sup>) GP loader bucket and standard equipment unless otherwise specified.

BACKHOE DIMENSIONS AND PERFORMANCE	Standard Stick		Extendible Stick Retracted		Extendible Stick Extended	
	14) Digging depth, SAE (maximum)	4348 mm	14'3"	4389 mm	14'5"	5441 mm
15) Digging depth, 610 mm (2'0") flat bottom	4309 mm	14'2"	4350 mm	14'3"	5404 mm	17'9"
Reach from rear axle centerline at ground line	6702 mm	22'0"	6738 mm	22'1"	7742 mm	25'5"
16) Reach from swing pivot at ground line	5612 mm	18'5"	5648 mm	18'6"	6652 mm	21'10"
Maximum operating height	5525 mm	18'2"	5549 mm	18'2"	6286 mm	20'7"
Loading height	3643 mm	11'11"	3600 mm	11'10"	4170 mm	13'8"
17) Loading reach	1838 mm	6'0"	1925 mm	6'4"	2840 mm	9'4"
Swing arc		180°		180°		180°
Bucket rotation		205°		204°		204°
18) Stabilizer spread, operating position (center of pad)	3310 mm	10'10"	3310 mm	10'10"	3310 mm	10'10"
19) Stabilizer spread, operating position (outside edge of pad)	3770 mm	12'4"	3770 mm	12'4"	3770 mm	12'4"
Stabilizer spread, transport position	2322 mm	7'7"	2322 mm	7'7"	2322 mm	7'7"
Bucket dig force	59.1 kN	13,290 lbf	58.3 kN	13,103 lbf	58.3 kN	13,103 lbf
Stick dig force	32.4 kN	7276 lbf	32.4 kN	7286 lbf	23.8 kN	5346 lbf



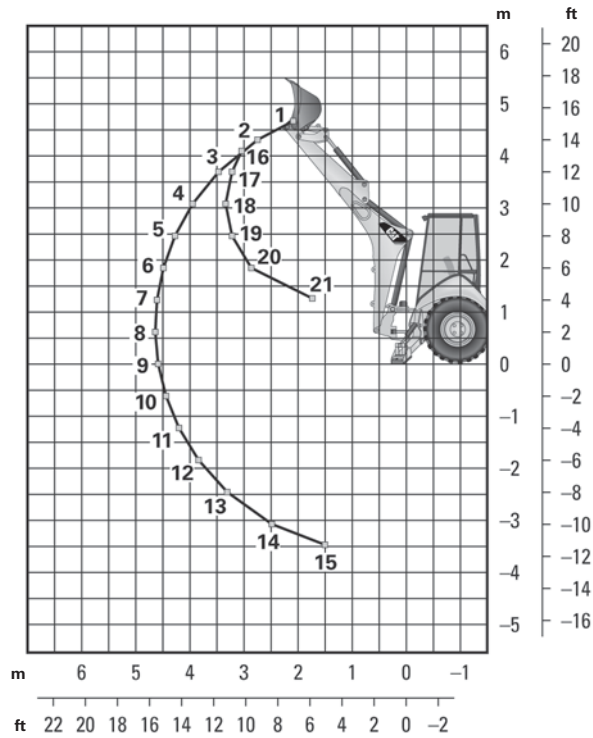

### Standard Stick

#### Boom Lifting

1	1296 kg	<b>2851 lb</b>
2	1410 kg	<b>3101 lb</b>
3	1419 kg	<b>3123 lb</b>
4	1379 kg	<b>3033 lb</b>
5	1326 kg	<b>2917 lb</b>
6	1271 kg	<b>2797 lb</b>
7	1218 kg	<b>2680 lb</b>
8	1168 kg	<b>2569 lb</b>
9	1121 kg	<b>2466 lb</b>
10	1078 kg	<b>2372 lb</b>
11	1039 kg	<b>2286 lb</b>
12	1006 kg	<b>2213 lb</b>
13	981 kg	<b>2157 lb</b>
14	979 kg	<b>2153 lb</b>
15	1073 kg	<b>2361 lb</b>

#### Stick Lifting

16	1312 kg	<b>2885 lb</b>
17	1849 kg	<b>4068 lb</b>
18	2307 kg	<b>5075 lb</b>
19	2400 kg	<b>5280 lb</b>
20	2790 kg	<b>6137 lb</b>
21	5561 kg	<b>12,234 lb</b>

Lift Capacities are over-end values. Machine equipped with AWD, OROPS, 0.76 m<sup>3</sup> (1.0 yd<sup>3</sup>) general purpose bucket, and 115 kg (255 lb) counterweight. Extendible stick includes 460 kg (1015 lb) counterweight.

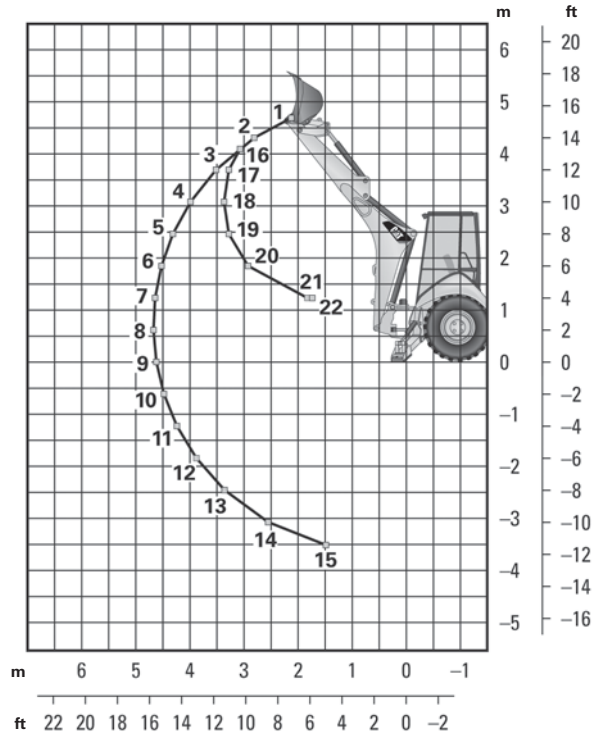

**Extendible Stick Retracted**

Boom Lifting

1	1117 kg	<b>2457 lb</b>
2	1214 kg	<b>2670 lb</b>
3	1212 kg	<b>2665 lb</b>
4	1166 kg	<b>2566 lb</b>
5	1111 kg	<b>2444 lb</b>
6	1054 kg	<b>2319 lb</b>
7	999 kg	<b>2197 lb</b>
8	946 kg	<b>2082 lb</b>
9	897 kg	<b>1974 lb</b>
10	852 kg	<b>1873 lb</b>
11	809 kg	<b>1780 lb</b>
12	771 kg	<b>1696 lb</b>
13	738 kg	<b>1623 lb</b>
14	718 kg	<b>1580 lb</b>
15	767 kg	<b>1687 lb</b>

Stick Lifting

16	1169 kg	<b>2572 lb</b>
17	1694 kg	<b>3726 lb</b>
18	2107 kg	<b>4634 lb</b>
19	2183 kg	<b>4802 lb</b>
20	2533 kg	<b>5573 lb</b>
21	4983 kg	<b>10,963 lb</b>
22	5330 kg	<b>11,725 lb</b>

Lift Capacities are over-end values. Machine equipped with AWD, OROPS, 0.76 m<sup>3</sup> (1.0 yd<sup>3</sup>) general purpose bucket, and 115 kg (255 lb) counterweight. Extendible stick includes 460 kg (1015 lb) counterweight.

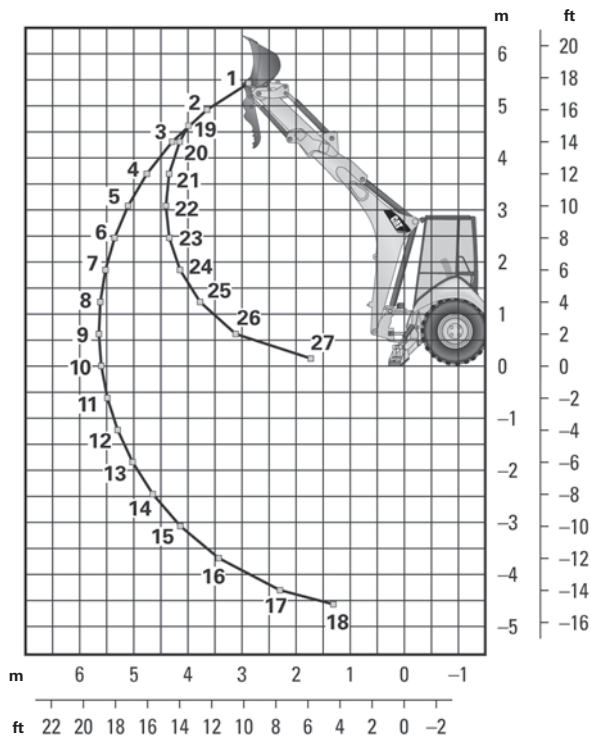

**Extendible Stick Extended**

Boom Lifting

1	617 kg	<b>1357 lb</b>
2	750 kg	<b>1650 lb</b>
3	797 kg	<b>1752 lb</b>
4	802 kg	<b>1765 lb</b>
5	791 kg	<b>1741 lb</b>
6	770 kg	<b>1695 lb</b>
7	750 kg	<b>1649 lb</b>
8	726 kg	<b>1597 lb</b>
9	702 kg	<b>1544 lb</b>
10	679 kg	<b>1493 lb</b>
11	657 kg	<b>1445 lb</b>
12	637 kg	<b>1401 lb</b>
13	620 kg	<b>1363 lb</b>
14	607 kg	<b>1334 lb</b>
15	601 kg	<b>1322 lb</b>
16	612 kg	<b>1347 lb</b>
17	699 kg	<b>1537 lb</b>
18	1030 kg	<b>2267 lb</b>

Stick Lifting

19	552 kg	<b>1214 lb</b>
20	735 kg	<b>1617 lb</b>
21	987 kg	<b>2171 lb</b>
22	1162 kg	<b>2556 lb</b>
23	1307 kg	<b>2876 lb</b>
24	1460 kg	<b>3212 lb</b>
25	1679 kg	<b>3694 lb</b>
26	2192 kg	<b>4823 lb</b>
27	5301 kg	<b>11,662 lb</b>

Lift Capacities are over-end values. Machine equipped with AWD, OROPS, 0.76 m<sup>3</sup> (1.0 yd<sup>3</sup>) general purpose bucket, and 115 kg (255 lb) counterweight. Extendible stick includes 460 kg (1015 lb) counterweight.

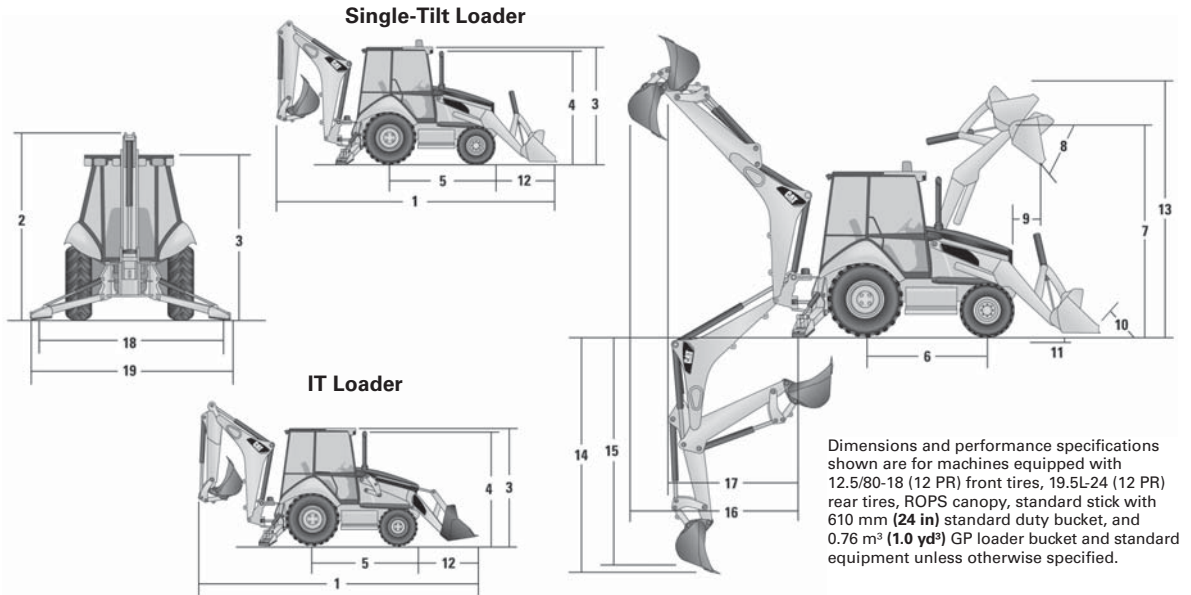

MACHINE DIMENSIONS	Single-Tilt Loader							
	General Purpose 0.96 m <sup>3</sup> (1.25 yd <sup>3</sup> )		General Purpose 1.0 m <sup>3</sup> (1.31 yd <sup>3</sup> )		General Purpose 1.07 m <sup>3</sup> (1.4 yd <sup>3</sup> )		General Purpose 1.15 m <sup>3</sup> (1.5 yd <sup>3</sup> )	
1) Overall transport length	7169 mm	23'6"	7136 mm	23'5"	7208 mm	23'8"	7208 mm	23'8"
Overall length	7141 mm	23'5"	7096 mm	23'3"	7161 mm	23'6"	7161 mm	23'6"
2) Overall transport height S-stick	3577 mm	11'9"	3577 mm	11'9"	3577 mm	11'9"	3577 mm	11'9"
Overall transport height E-stick	3631 mm	11'11"	3631 mm	11'11"	3631 mm	11'11"	3631 mm	11'11"
Overall width	2322 mm	7'7"	2322 mm	7'7"	2322 mm	7'7"	2322 mm	7'7"
3) Height to top of cab/canopy	2819 mm	9'3"	2819 mm	9'3"	2819 mm	9'3"	2819 mm	9'3"
4) Height to top of exhaust stack	2744 mm	9'0"	2744 mm	9'0"	2744 mm	9'0"	2744 mm	9'0"
Ground clearance (LH step)	294 mm	1'0"	294 mm	1'0"	294 mm	1'0"	294 mm	1'0"
Ground clearance (AWD guard)	294 mm	1'0"	294 mm	1'0"	294 mm	1'0"	294 mm	1'0"
Ground clearance (485 kg/ 1170 lb counterweight)	274 mm	11"	274 mm	11"	274 mm	11"	274 mm	11"
5) Rear axle centerline to front grill	2705 mm	8'10"	2705 mm	8'10"	2705 mm	8'10"	2705 mm	8'10"
Front wheel tread gauge	1895 mm	6'3"	1895 mm	6'3"	1895 mm	6'3"	1895 mm	6'3"
Rear wheel tread gauge	1714 mm	5'7"	1714 mm	5'7"	1714 mm	5'7"	1714 mm	5'7"
6) Wheelbase (2WD/AWD)	2200 mm	7'3"	2200 mm	7'3"	2200 mm	7'3"	2200 mm	7'3"

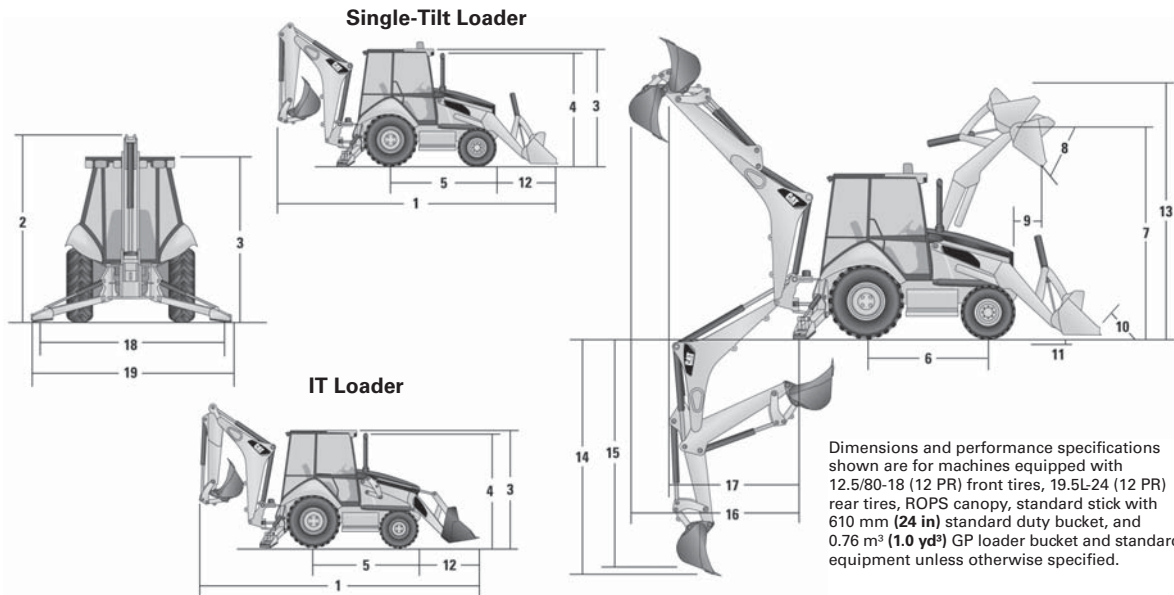

MACHINE DIMENSIONS	Single-Tilt Loader							
	Multi Purpose 1.0 m <sup>3</sup> (1.31 yd <sup>3</sup> )		Multi Purpose 1.07 m <sup>3</sup> (1.4 yd <sup>3</sup> )		Multi Purpose with Forks 1.0 m <sup>3</sup> (1.31 yd <sup>3</sup> )		Multi Purpose with Forks 1.07 m <sup>3</sup> (1.4 yd <sup>3</sup> )	
1) Overall transport length	7133 mm	23'5"	7133 mm	23'5"	7133 mm	23'5"	7133 mm	23'5"
Overall length	7059 mm	23'2"	7059 mm	23'2"	7059 mm	23'2"	7059 mm	23'2"
2) Overall transport height S-stick	3577 mm	11'9"	3577 mm	11'9"	3577 mm	11'9"	3577 mm	11'9"
Overall transport height E-stick	3631 mm	11'11"	3631 mm	11'11"	3631 mm	11'11"	3631 mm	11'11"
Overall width	2322 mm	7'7"	2322 mm	7'7"	2322 mm	7'7"	2322 mm	7'7"
3) Height to top of cab/canopy	2819 mm	9'3"	2819 mm	9'3"	2819 mm	9'3"	2819 mm	9'3"
4) Height to top of exhaust stack	2744 mm	9'0"	2744 mm	9'0"	2744 mm	9'0"	2744 mm	9'0"
Ground clearance (LH step)	294 mm	1'0"	294 mm	1'0"	294 mm	1'0"	294 mm	1'0"
Ground clearance (AWD guard)	294 mm	1'0"	294 mm	1'0"	294 mm	1'0"	294 mm	1'0"
Ground clearance (485 kg/ 1170 lb counterweight)	274 mm	11"	274 mm	11"	274 mm	11"	274 mm	11"
5) Rear axle centerline to front grill	2705 mm	8'10"	2705 mm	8'10"	2705 mm	8'10"	2705 mm	8'10"
Front wheel tread gauge	1895 mm	6'3"	1895 mm	6'3"	1895 mm	6'3"	1895 mm	6'3"
Rear wheel tread gauge	1714 mm	5'7"	1714 mm	5'7"	1714 mm	5'7"	1714 mm	5'7"
6) Wheelbase (2WD/AWD)	2200 mm	7'3"	2200 mm	7'3"	2200 mm	7'3"	2200 mm	7'3"

MACHINE DIMENSIONS	IT Loader with Quick Coupler					
	General Purpose 0.96 m <sup>3</sup> (1.25 yd <sup>3</sup> )		General Purpose 1.0 m <sup>3</sup> (1.31 yd <sup>3</sup> )		General Purpose 1.15 m <sup>3</sup> (1.5 yd <sup>3</sup> )	
1) Overall transport length	7282 mm	23'11"	7250 mm	23'9"	7279 mm	23'11"
Overall length	7289 mm	23'11"	7244 mm	23'9"	7287 mm	23'11"
2) Overall transport height S-stick	3577 mm	11'9"	3577 mm	11'9"	3577 mm	11'9"
Overall transport height E-stick	3631 mm	11'11"	3631 mm	11'11"	3631 mm	11'11"
Overall width	2322 mm	7'7"	2322 mm	7'7"	2322 mm	7'7"
3) Height to top of cab/canopy	2819 mm	9'3"	2819 mm	9'3"	2819 mm	9'3"
4) Height to top of exhaust stack	2744 mm	9'0"	2744 mm	9'0"	2744 mm	9'0"
Ground clearance (LH step)	294 mm	1'0"	294 mm	1'0"	294 mm	1'0"
Ground clearance (AWD guard)	294 mm	1'0"	294 mm	1'0"	294 mm	1'0"
Ground clearance (485 kg/1170 lb counterweight)	274 mm	11"	274 mm	11"	274 mm	11"
5) Rear axle centerline to front grill	2705 mm	8'10"	2705 mm	8'10"	2705 mm	8'10"
Front wheel tread gauge	1895 mm	6'3"	1895 mm	6'3"	1895 mm	6'3"
Rear wheel tread gauge	1714 mm	5'7"	1714 mm	5'7"	1714 mm	5'7"
6) Wheelbase (2WD/AWD)	2200 mm	7'3"	2200 mm	7'3"	2200 mm	7'3"

MACHINE DIMENSIONS	IT Loader with Quick Coupler			
	Multi Purpose 1.0 m <sup>3</sup> (1.31 yd <sup>3</sup> )		Multi Purpose 1.07 m <sup>3</sup> (1.4 yd <sup>3</sup> )	
1) Overall transport length	7211 mm	23'8"	7211 mm	23'8"
Overall length	7197 mm	23'7"	7197 mm	23'7"
2) Overall transport height S-stick	3577 mm	11'9"	3577 mm	11'9"
Overall transport height E-stick	3631 mm	11'11"	3631 mm	11'11"
Overall width	2322 mm	7'7"	2322 mm	7'7"
3) Height to top of cab/canopy	2819 mm	9'3"	2819 mm	9'3"
4) Height to top of exhaust stack	2744 mm	9'0"	2744 mm	9'0"
Ground clearance (LH step)	294 mm	1'0"	294 mm	1'0"
Ground clearance (AWD guard)	294 mm	1'0"	294 mm	1'0"
Ground clearance (485 kg/1170 lb counterweight)	274 mm	11"	274 mm	11"
5) Rear axle centerline to front grill	2705 mm	8'10"	2705 mm	8'10"
Front wheel tread gauge	1895 mm	6'3"	1895 mm	6'3"
Rear wheel tread gauge	1714 mm	5'7"	1714 mm	5'7"
6) Wheelbase (2WD/AWD)	2200 mm	7'3"	2200 mm	7'3"

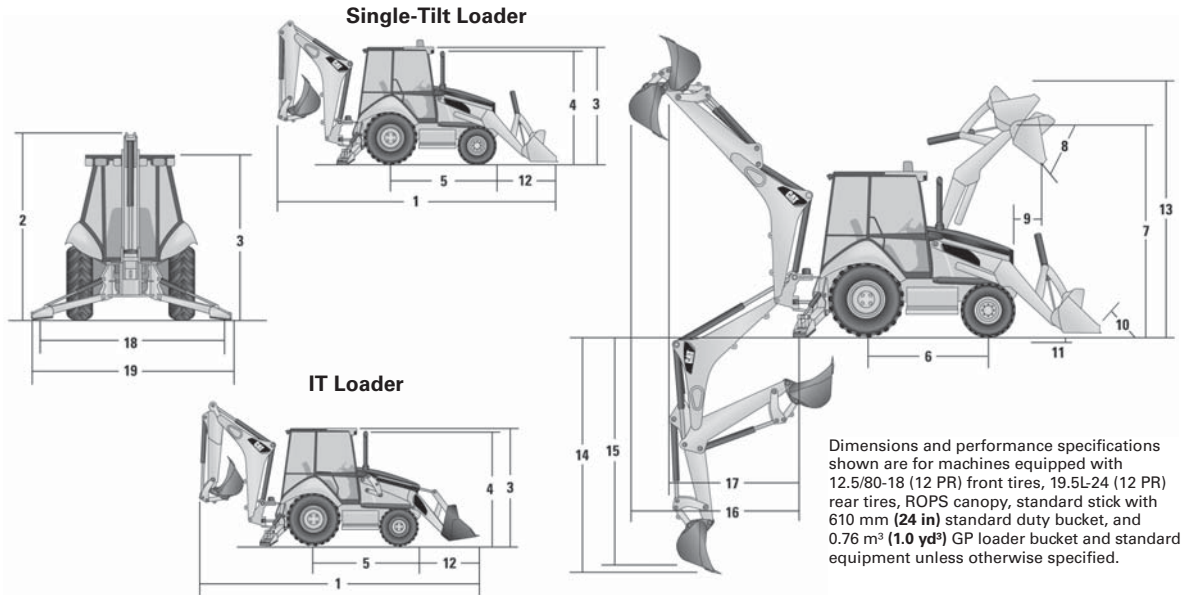

LOADER BUCKET DIMENSIONS AND PERFORMANCE	Single-Tilt Loader							
	General Purpose 0.96 m³ (1.25 yd³)		General Purpose 1.0 m³ (1.31 yd³)		General Purpose 1.07 m³ (1.4 yd³)		General Purpose 1.15 m³ (1.5 yd³)	
Capacity (SAE) rated	0.96 m³	<b>1.25 yd³</b>	1.0 m³	<b>1.31 yd³</b>	1.07 m³	<b>1.4 yd³</b>	1.15 m³	<b>1.5 yd³</b>
Width	2262 mm	<b>89"</b>	2406 mm	<b>95"</b>	2262 mm	<b>89"</b>	2406 mm	<b>95"</b>
Lift capacity at maximum height	3283 kg	<b>7237 lb</b>	3292 kg	<b>7257 lb</b>	3216 kg	<b>7090 lb</b>	3196 kg	<b>7046 lb</b>
Lift breakout force	49.8 kN	<b>11,197 lbf</b>	50.6 kN	<b>11,367 lbf</b>	49.3 kN	<b>11,077 lbf</b>	49.1 kN	<b>11,037 lbf</b>
Tilt breakout force	50.2 kN	<b>11,283 lbf</b>	53.4 kN	<b>11,995 lbf</b>	51.2 kN	<b>11,518 lbf</b>	51.1 kN	<b>11,494 lbf</b>
7) Maximum hinge pin height	3474 mm	<b>11'5"</b>	3474 mm	<b>11'5"</b>	3474 mm	<b>11'5"</b>	3474 mm	<b>11'5"</b>
8) Dump angle at full height		<b>44°</b>		<b>44°</b>		<b>44°</b>		<b>44°</b>
Dump height at maximum angle	2746 mm	<b>9'0"</b>	2777 mm	<b>9'1"</b>	2723 mm	<b>8'11"</b>	2723 mm	<b>8'11"</b>
9) Dump reach at maximum angle	808 mm	<b>2'8"</b>	775 mm	<b>2'7"</b>	773 mm	<b>2'6"</b>	773 mm	<b>2'6"</b>
10) Maximum bucket rollback at ground level		<b>37°</b>		<b>37°</b>		<b>38°</b>		<b>38°</b>
11) Digging depth	83 mm	<b>3"</b>	83 mm	<b>3"</b>	123 mm	<b>5"</b>	123 mm	<b>5"</b>
Maximum grading angle		<b>112°</b>		<b>114°</b>		<b>113°</b>		<b>113°</b>
Width of dozer cutting edge		<b>N/A</b>		<b>N/A</b>		<b>N/A</b>		<b>N/A</b>
12) Grill to bucket cutting edge, carry position	1487 mm	<b>4'11"</b>	1454 mm	<b>4'10"</b>	1525 mm	<b>5'1"</b>	1525 mm	<b>5'1"</b>
13) Maximum operating height	4355 mm	<b>14'3"</b>	4353 mm	<b>13'9"</b>	4395 mm	<b>13'11"</b>	4395 mm	<b>13'11"</b>
Jaw opening maximum		<b>N/A</b>		<b>N/A</b>		<b>N/A</b>		<b>N/A</b>
Bucket jaw clamping force		<b>N/A</b>		<b>N/A</b>		<b>N/A</b>		<b>N/A</b>
Weight (does not include teeth or forks)	451 kg	<b>994 lb</b>	462 kg	<b>1019 lb</b>	473 kg	<b>1043 lb</b>	493 kg	<b>1087 lb</b>

LOADER BUCKET DIMENSIONS AND PERFORMANCE	Single-Tilt Loader							
	Multi Purpose 1.0 m <sup>3</sup> (1.31 yd <sup>3</sup> )		Multi Purpose 1.07 m <sup>3</sup> (1.4 yd <sup>3</sup> )		Multi Purpose with Forks 1.0 m <sup>3</sup> (1.31 yd <sup>3</sup> )		Multi Purpose with Forks 1.07 m <sup>3</sup> (1.4 yd <sup>3</sup> )	
Capacity (SAE) rated	1.0 m <sup>3</sup>	<b>1.31 yd<sup>3</sup></b>	1.07 m <sup>3</sup>	<b>1.4 yd<sup>3</sup></b>	1.0 m <sup>3</sup>	<b>1.31 yd<sup>3</sup></b>	1.07 m <sup>3</sup>	<b>1.4 yd<sup>3</sup></b>
Width	2279 mm	<b>90"</b>	2425 mm	<b>95"</b>	2279 mm	<b>90"</b>	2425 mm	<b>95"</b>
Lift capacity at maximum height	3097 kg	<b>6828 lb</b>	3068 kg	<b>6764 lb</b>	2982 kg	<b>6575 lb</b>	2953 kg	<b>6511 lb</b>
Lift breakout force	49.0 kN	<b>11,020 lbf</b>	48.8 kN	<b>10,964 lbf</b>	47.5 kN	<b>10,685 lbf</b>	47.3 kN	<b>10,629 lbf</b>
Tilt breakout force	57.6 kN	<b>12,938 lbf</b>	57.4 kN	<b>12,905 lbf</b>	56.6 kN	<b>12,733 lbf</b>	56.5 kN	<b>12,700 lbf</b>
7) Maximum hinge pin height	3474 mm	<b>11'5"</b>	3474 mm	<b>11'5"</b>	3474 mm	<b>11'5"</b>	3474 mm	<b>11'5"</b>
8) Dump angle at full height		<b>44°</b>		<b>44°</b>		<b>44°</b>		<b>44°</b>
Dump height at maximum angle	2798 mm	<b>9'2"</b>	2798 mm	<b>9'2"</b>	2798 mm	<b>9'2"</b>	2798 mm	<b>9'2"</b>
9) Dump reach at maximum angle	716 mm	<b>2'4"</b>	716 mm	<b>2'4"</b>	716 mm	<b>2'4"</b>	716 mm	<b>2'4"</b>
10) Maximum bucket rollback at ground level		<b>38°</b>		<b>38°</b>		<b>38°</b>		<b>38°</b>
11) Digging depth	110 mm	<b>4"</b>	110 mm	<b>4"</b>	110 mm	<b>4"</b>	110 mm	<b>4"</b>
Maximum grading angle		<b>116°</b>		<b>116°</b>		<b>116°</b>		<b>116°</b>
Width of dozer cutting edge	2262 mm	<b>7'5"</b>	2406 mm	<b>7'11"</b>	2262 mm	<b>7'5"</b>	2406 mm	<b>7'11"</b>
12) Grill to bucket cutting edge, carry position	1451 mm	<b>4'9"</b>	1451 mm	<b>4'9"</b>	1451 mm	<b>4'9"</b>	1451 mm	<b>4'9"</b>
13) Maximum operating height	4404 mm	<b>14'5"</b>	4404 mm	<b>14'5"</b>	4878 mm	<b>16'0"</b>	4878 mm	<b>16'0"</b>
Jaw opening maximum	790 mm	<b>2'7"</b>	790 mm	<b>2'7"</b>	790 mm	<b>2'7"</b>	790 mm	<b>2'7"</b>
Bucket jaw clamping force	55.7 kN	<b>12,521 lbf</b>	55.7 kN	<b>12,521 lbf</b>	55.7 kN	<b>12,521 lbf</b>	55.7 kN	<b>12,521 lbf</b>
Weight (does not include teeth or forks)	745 kg	<b>1642 lb</b>	774 kg	<b>1706 lb</b>	915 kg	<b>2017 lb</b>	936 kg	<b>2064 lb</b>

LOADER BUCKET DIMENSIONS AND PERFORMANCE	IT Loader with Quick Coupler					
	General Purpose 0.96 m <sup>3</sup> (1.25 yd <sup>3</sup> )		General Purpose 1.0 m <sup>3</sup> (1.31 yd <sup>3</sup> )		General Purpose 1.15 m <sup>3</sup> (1.5 yd <sup>3</sup> )	
Capacity (SAE) rated	0.96 m <sup>3</sup>	<b>1.25 yd<sup>3</sup></b>	1.0 m <sup>3</sup>	<b>1.31 yd<sup>3</sup></b>	1.15 m <sup>3</sup>	<b>1.5 yd<sup>3</sup></b>
Width	2262 mm	<b>89"</b>	2406 mm	<b>95"</b>	2406 mm	<b>95"</b>
Lift capacity at maximum height	3716 kg	<b>8193 lb</b>	3707 kg	<b>8173 lb</b>	3682 kg	<b>8117 lb</b>
Lift breakout force	51.1 kN	<b>11,484 lbf</b>	51.5 kN	<b>11,575 lbf</b>	50.8 kN	<b>11,415 lbf</b>
Tilt breakout force	46.3 kN	<b>10,411 lbf</b>	48.9 kN	<b>10,999 lbf</b>	46.1 kN	<b>10,371 lbf</b>
7) Maximum hinge pin height	3490 mm	<b>11'5"</b>	3490 mm	<b>11'5"</b>	3490 mm	<b>11'5"</b>
8) Dump angle at full height		<b>44°</b>		<b>44°</b>		<b>44°</b>
Dump height at maximum angle	2679 mm	<b>8'9"</b>	2710 mm	<b>8'11"</b>	2680 mm	<b>8'10"</b>
9) Dump reach at maximum angle	869 mm	<b>2'10"</b>	836 mm	<b>2'9"</b>	868 mm	<b>2'10"</b>
10) Maximum bucket rollback at ground level		<b>40°</b>		<b>40°</b>		<b>40°</b>
11) Digging depth	105 mm	<b>4"</b>	105 mm	<b>4"</b>	105 mm	<b>4"</b>
Maximum grading angle		<b>110°</b>		<b>111°</b>		<b>110°</b>
Width of dozer cutting edge		<b>N/A</b>		<b>N/A</b>		<b>N/A</b>
12) Grill to bucket cutting edge, carry position	1600 mm	<b>5'3"</b>	1568 mm	<b>5'2"</b>	1597 mm	<b>5'3"</b>
13) Maximum operating height	4407 mm	<b>14'6"</b>	4407 mm	<b>14'6"</b>	4477 mm	<b>14'8"</b>
Jaw opening maximum		<b>N/A</b>		<b>N/A</b>		<b>N/A</b>
Bucket jaw clamping force		<b>N/A</b>		<b>N/A</b>		<b>N/A</b>
Weight (does not include teeth or forks)	447 kg	<b>985 lb</b>	457 kg	<b>1008 lb</b>	481 kg	<b>1060 lb</b>



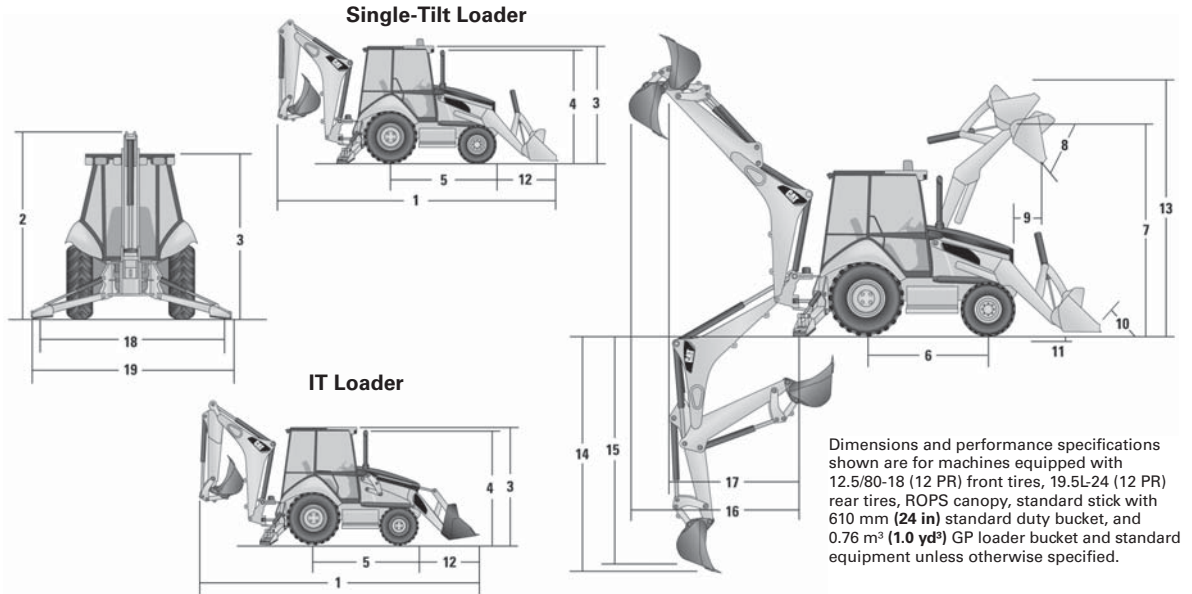

LOADER BUCKET DIMENSIONS AND PERFORMANCE	IT Loader with Quick Coupler			
	Multi Purpose 1.0 m <sup>3</sup> (1.31 yd <sup>3</sup> )		Multi Purpose 1.07 m <sup>3</sup> (1.4 yd <sup>3</sup> )	
Capacity (SAE) rated	1.0 m <sup>3</sup>	<b>1.31 yd<sup>3</sup></b>	1.07 m <sup>3</sup>	<b>1.4 yd<sup>3</sup></b>
Width	2279 mm	<b>90"</b>	2425 mm	<b>95"</b>
Lift capacity at maximum height	3448 kg	<b>7601 lb</b>	3419 kg	<b>7537 lb</b>
Lift breakout force	49.7 kN	<b>11,168 lbf</b>	49.4 kN	<b>11,108 lbf</b>
Tilt breakout force	50.4 kN	<b>11,325 lbf</b>	50.2 kN	<b>11,288 lbf</b>
7) Maximum hinge pin height	3490 mm	<b>11'5"</b>	3490 mm	<b>11'5"</b>
8) Dump angle at full height		<b>44°</b>		<b>44°</b>
Dump height at maximum angle	2745 mm	<b>9'0"</b>	2745 mm	<b>9'0"</b>
9) Dump reach at maximum angle	814 mm	<b>2'8"</b>	814 mm	<b>2'8"</b>
10) Maximum bucket rollback at ground level		<b>39°</b>		<b>39°</b>
11) Digging depth	95 mm	<b>4"</b>	95 mm	<b>4"</b>
Maximum grading angle		<b>112°</b>		<b>112°</b>
Width of dozer cutting edge	2262 mm	<b>7'5"</b>	2406 mm	<b>7'11"</b>
12) Grill to bucket cutting edge, carry position	1529 mm	<b>5'0"</b>	1529 mm	<b>5'0"</b>
13) Maximum operating height	4480 mm	<b>14'8"</b>	4480 mm	<b>14'8"</b>
Jaw opening maximum	790 mm	<b>2'7"</b>	790 mm	<b>2'7"</b>
Bucket jaw clamping force	55.7 kN	<b>12,521 lbf</b>	55.7 kN	<b>12,521 lbf</b>
Weight (does not include teeth or forks)	724 kg	<b>1596 lb</b>	753 kg	<b>1660 lb</b>

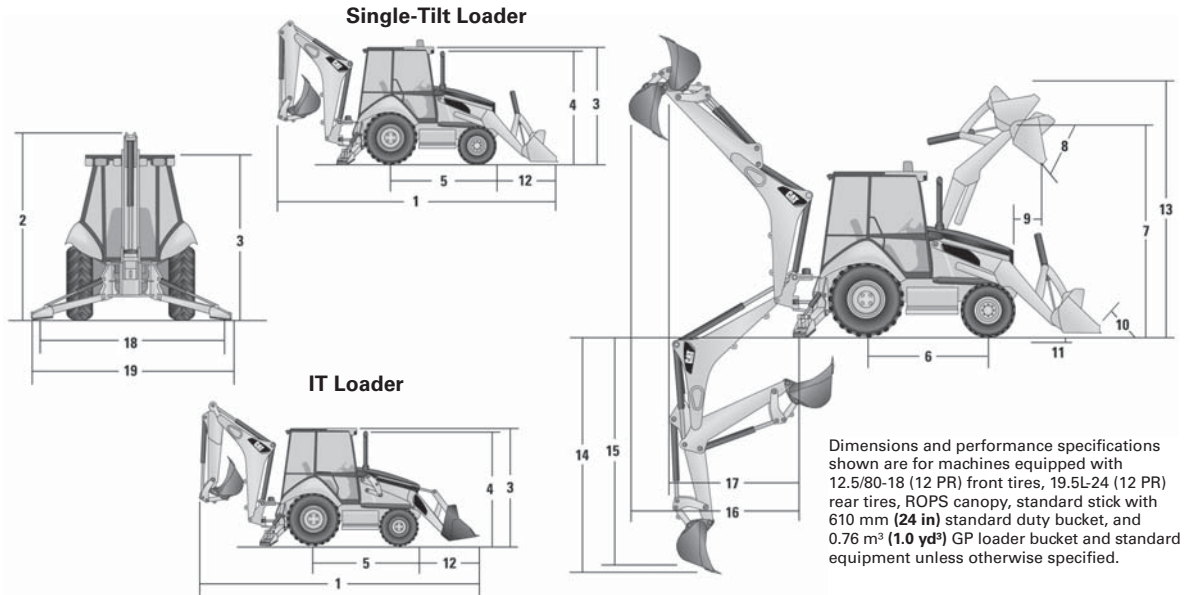

Dimensions and performance specifications shown are for machines equipped with 12.5/80-18 (12 PR) front tires, 19.5L-24 (12 PR) rear tires, ROPS canopy, standard stick with 610 mm (24 in) standard duty bucket, and 0.76 m<sup>3</sup> (1.0 yd<sup>3</sup>) GP loader bucket and standard equipment unless otherwise specified.

BACKHOE DIMENSIONS AND PERFORMANCE	Standard Stick		Extendible Stick Retracted		Extendible Stick Extended	
	14) Digging depth, SAE (maximum)	4350 mm	14'3"	4390 mm	14'5"	5442 mm
15) Digging depth, 610 mm (2'0") flat bottom	4311 mm	14'2"	4351 mm	14'3"	5405 mm	17'9"
Reach from rear axle centerline at ground line	6702 mm	22'0"	6737 mm	22'1"	7742 mm	25'5"
16) Reach from swing pivot at ground line	5612 mm	18'5"	5647 mm	18'6"	6652 mm	21'10"
Maximum operating height	5522 mm	18'1"	5546 mm	18'2"	6282 mm	20'7"
Loading height	3642 mm	11'11"	3599 mm	11'10"	4169 mm	13'8"
17) Loading reach	1842 mm	6'1"	1929 mm	6'4"	2844 mm	9'4"
Swing arc	180°		180°		180°	
Bucket rotation	205°		204°		204°	
18) Stabilizer spread, operating position (center of pad)	3310 mm	10'10"	3310 mm	10'10"	3310 mm	10'10"
19) Stabilizer spread, operating position (outside edge of pad)	3770 mm	12'4"	3770 mm	12'4"	3770 mm	12'4"
Stabilizer spread, transport position	2322 mm	7'7"	2322 mm	7'7"	2322 mm	7'7"
Bucket dig force	64.2 kN	14,431 lbf	63.3 kN	14,228 lbf	63.3 kN	14,228 lbf
Stick dig force	43.5 kN	9781 lbf	43.4 kN	9757 lbf	31.7 kN	7122 lbf

DIMENSIONS WITH FORKS/ MATERIAL-HANDLING ARM	Cat 420F2 IT Operating Specifications with Forks					
	1070 mm (3'6")		1220 mm (4'0")		1370 mm (4'6")	
Fork Tine Length	2340 kg	<b>5159 lb</b>	2263 kg	<b>4990 lb</b>	2191 kg	<b>4829 lb</b>
Operating load (SAE J1197)	535 mm	<b>1'9"</b>	610 mm	<b>2'0"</b>	685 mm	<b>2'3"</b>
SAE load center	2772 kg	<b>6111 lb</b>	2749 kg	<b>6062 lb</b>	2726 kg	<b>6009 lb</b>
Operating load (CEN 474-4)	500 mm	<b>1'8"</b>	500 mm	<b>1'8"</b>	500 mm	<b>1'8"</b>
CEN load center	7681 mm	<b>25'2"</b>	7832 mm	<b>25'8"</b>	7980 mm	<b>26'2"</b>
Overall length (A) (forks on ground)						

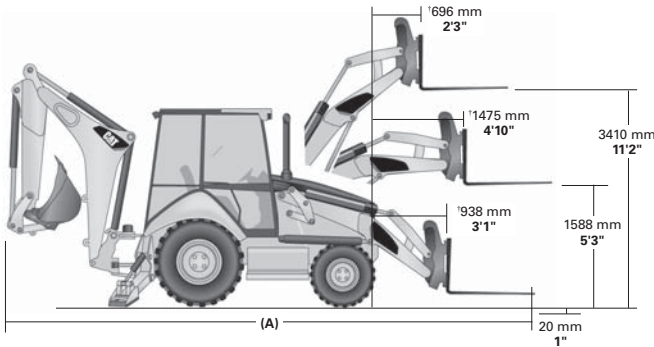

Operating load is hydraulic and tip limited.

*†Measured from nose of machine.*

DIMENSIONS WITH FORKS/ MATERIAL-HANDLING ARM	Cat 420F2 IT Operating Specifications with Material Handling Arm					
	Retracted		Mid-Position		Extended	
Material-Handling Arm Position	1058 kg	<b>2333 lb</b>	674 kg	<b>1487 lb</b>	495 kg	<b>1092 lb</b>
Operating load (SAE J1197 and CEN 474-4)	8867 mm	<b>29'1"</b>	9864 mm	<b>32'4"</b>	10 864 mm	<b>35'8"</b>
Overall length, maximum						

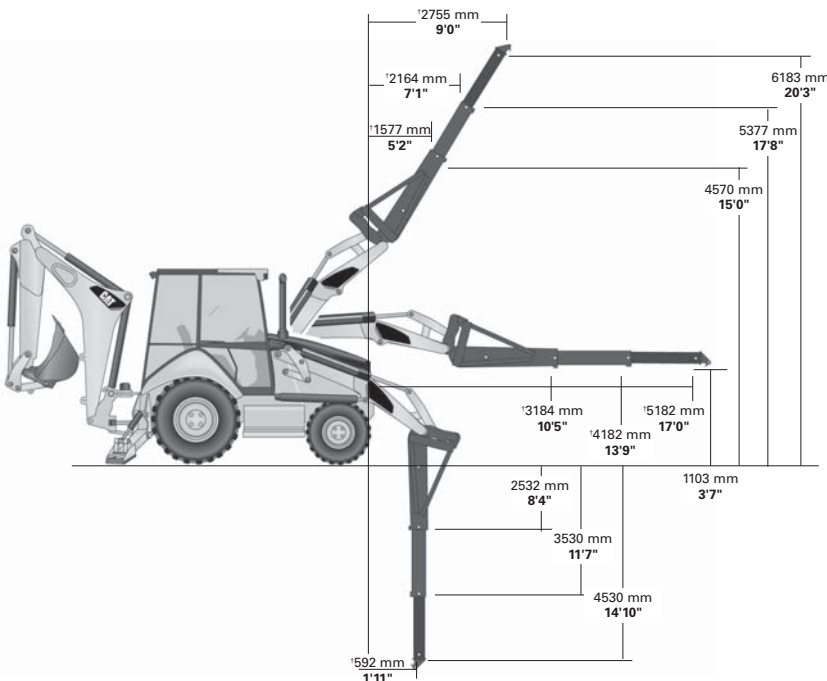

Operating load is hydraulic and tip limited.

Dimensions and performance specifications shown are for 4WD machines equipped with 12.5/80-18 I-3 front tires, 19.5L-24 R-4 ATU rear tires, ROPS canopy, standard stick with 610 mm (24 in) standard duty bucket, and 0.96 m<sup>3</sup> (1.25 yd<sup>3</sup>) loader bucket and standard equipment unless otherwise specified.

*†Measured from nose of machine.*

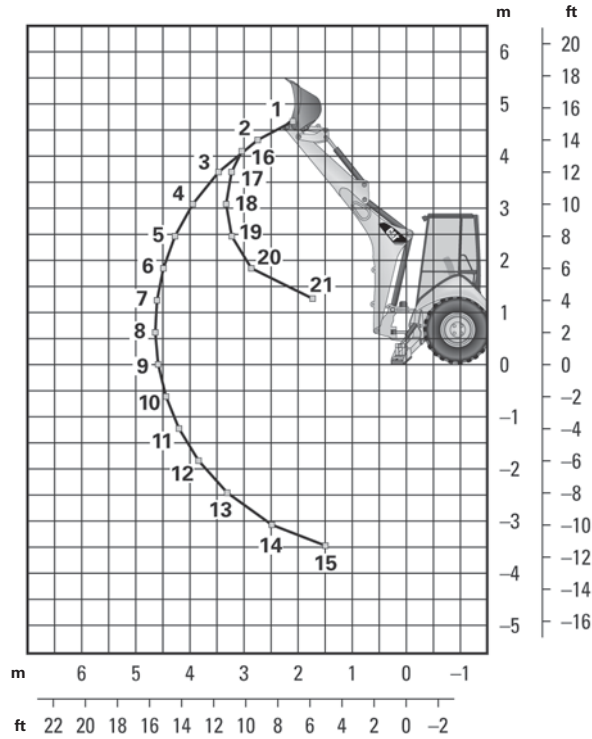

**Standard Stick**

Boom Lifting

1	1621 kg	3573 lb
2	1766 kg	3894 lb
3	1785 kg	3936 lb
4	1740 kg	3835 lb
5	1678 kg	3700 lb
6	1614 kg	3558 lb
7	1551 kg	3420 lb
8	1492 kg	3289 lb
9	1437 kg	3168 lb
10	1387 kg	3058 lb
11	1342 kg	2959 lb
12	1304 kg	2875 lb
13	1278 kg	2817 lb
14	1284 kg	2831 lb
15	1426 kg	3145 lb

Stick Lifting

16	1831 kg	4037 lb
17	2557 kg	5638 lb
18	2608 kg	5749 lb
19	2704 kg	5961 lb
20	3140 kg	6921 lb
21	6232 kg	13,739 lb

Lift Capacities are over-end values. Machine equipped with ST linkage, AWD, OROPS, 0.96 m<sup>3</sup> (1.25 yd<sup>3</sup>) general purpose bucket, and 240 kg (530 lb) counterweight. Extendible stick includes 460 kg (1015 lb) counterweight.

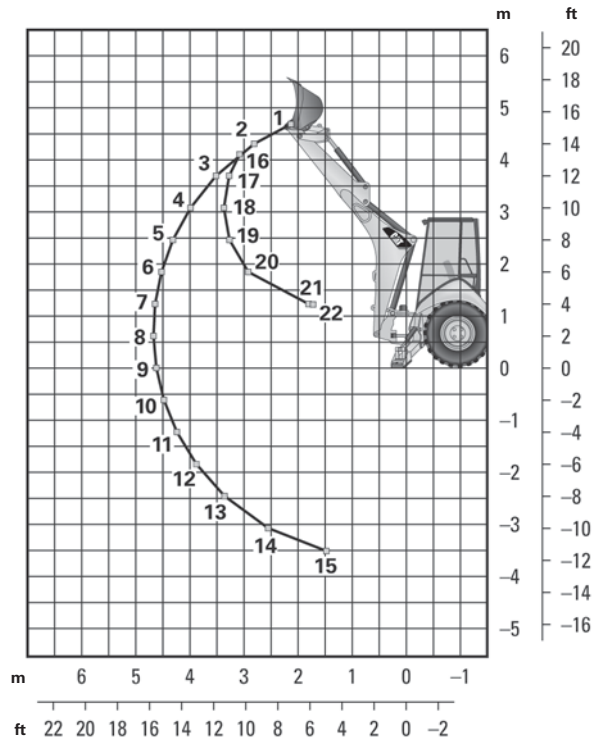

### Extendible Stick Retracted

#### Boom Lifting

1	1439 kg	<b>3173 lb</b>
2	1573 kg	<b>3468 lb</b>
3	1582 kg	<b>3487 lb</b>
4	1533 kg	<b>3380 lb</b>
5	1470 kg	<b>3241 lb</b>
6	1405 kg	<b>3097 lb</b>
7	1341 kg	<b>2957 lb</b>
8	1281 kg	<b>2823 lb</b>
9	1224 kg	<b>2699 lb</b>
10	1172 kg	<b>2584 lb</b>
11	1124 kg	<b>2479 lb</b>
12	1083 kg	<b>2387 lb</b>
13	1050 kg	<b>2314 lb</b>
14	1040 kg	<b>2293 lb</b>
15	1149 kg	<b>2534 lb</b>

#### Stick Lifting

16	1677 kg	<b>3697 lb</b>
17	2387 kg	<b>5262 lb</b>
18	2404 kg	<b>5301 lb</b>
19	2492 kg	<b>5493 lb</b>
20	2886 kg	<b>6362 lb</b>
21	5629 kg	<b>12,409 lb</b>
22	6024 kg	<b>13,281 lb</b>

Lift Capacities are over-end values. Machine equipped with ST linkage, AWD, OROPS, 0.96 m<sup>3</sup> (1.25 yd<sup>3</sup>) general purpose bucket, and 240 kg (530 lb) counterweight. Extendible stick includes 460 kg (1015 lb) counterweight.

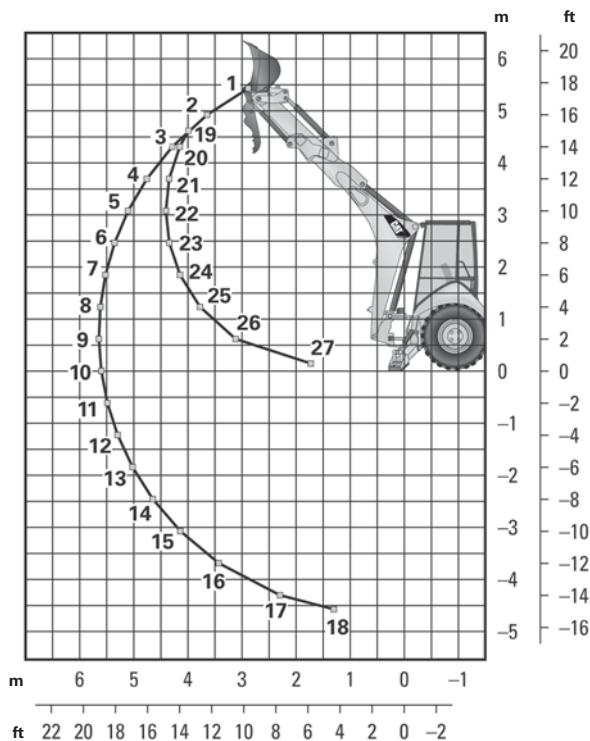

**Extendible Stick Extended**

Boom Lifting

1	838 kg	1849 lb
2	1010 kg	2226 lb
3	1073 kg	2366 lb
4	1085 kg	2392 lb
5	1070 kg	2358 lb
6	1041 kg	2296 lb
7	1030 kg	2271 lb
8	1003 kg	2212 lb
9	976 kg	2153 lb
10	950 kg	2095 lb
11	926 kg	2042 lb
12	905 kg	1994 lb
13	887 kg	1955 lb
14	875 kg	1928 lb
15	873 kg	1924 lb
16	895 kg	1973 lb
17	1023 kg	2255 lb
18	1502 kg	3311 lb

Stick Lifting

19	868 kg	1914 lb
20	1116 kg	2461 lb
21	1457 kg	3212 lb
22	1644 kg	3624 lb
23	1671 kg	3684 lb
24	1777 kg	3918 lb
25	2015 kg	4442 lb
26	2614 kg	5762 lb
27	5992 kg	13,209 lb

Lift Capacities are over-end values. Machine equipped with ST linkage, AWD, OROPS, 0.96 m<sup>3</sup> (1.25 yd<sup>3</sup>) general purpose bucket, and 240 kg (530 lb) counterweight. Extendible stick includes 460 kg (1015 lb) counterweight.

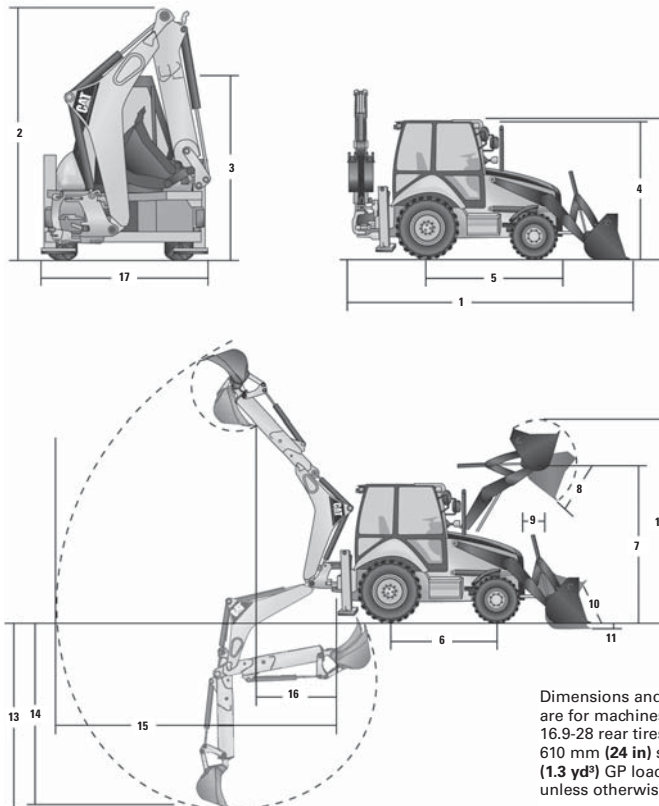

Dimensions and performance specifications shown are for machines equipped with 11L-16 front tires, 16.9-28 rear tires, ROPS canopy, standard stick with 610 mm (24 in) standard duty bucket, and 1.0 m<sup>3</sup> (1.3 yd<sup>3</sup>) GP loader bucket and standard equipment unless otherwise specified.

MACHINE DIMENSIONS	General Purpose 1.0 m <sup>3</sup> (1.31 yd <sup>3</sup> )		Multi Purpose 1.03 m <sup>3</sup> (1.35 yd <sup>3</sup> )		Multi Purpose with Forks 1.03 m <sup>3</sup> (1.35 yd <sup>3</sup> )	
	1) Overall length (loader on ground) Overall transport length	7333 mm 5772 mm	24'1" 18'11"	7327 mm 5728 mm	24'0" 18'10"	7327 mm 5728 mm
2) Overall transport height S-Stick Overall transport height E-Stick Overall width	3810 mm 3799 mm 2280 mm	12'6" 12'6" 7'6"	3810 mm 3799 mm 2280 mm	12'6" 12'6" 7'6"	3810 mm 3799 mm 2280 mm	12'6" 12'6" 7'6"
3) Height to top of cab/canopy	2829 mm	9'3"	2829 mm	9'3"	2829 mm	9'3"
4) Height to top of exhaust stack Height to loader hinge pin (transport) Ground clearance (stabilizer feet) Ground clearance (LH step) Ground clearance (AWD guard) Ground clearance (485 kg/1170 lb counterweight)	2681 mm 349 mm 347 mm 276 mm 263 mm 212 mm	8'10" 1'2" 1'2" 11" 10" 8"	2681 mm 316 mm 347 mm 276 mm 263 mm 212 mm	8'10" 1'0" 1'2" 11" 10" 8"	2681 mm 316 mm 347 mm 276 mm 263 mm 212 mm	8'10" 1'0" 1'2" 11" 10" 8"
5) Rear axle centerline to front grill Front wheel tread gauge Rear wheel tread gauge	2705 mm 1895 mm 1714 mm	8'10" 6'3" 5'7"	2705 mm 1895 mm 1714 mm	8'10" 6'3" 5'7"	2705 mm 1895 mm 1714 mm	8'10" 6'3" 5'7"
6) Wheelbase (AWD)	2200 mm	7'3"	2200 mm	7'3"	2200 mm	7'3"

LOADER BUCKET DIMENSIONS AND PERFORMANCE	General Purpose 1.0 m <sup>3</sup> (1.31 yd <sup>3</sup> )		Multi Purpose 1.03 m <sup>3</sup> (1.35 yd <sup>3</sup> )		Multi Purpose with Forks 1.03 m <sup>3</sup> (1.35 yd <sup>3</sup> )	
	Capacity (SAE) rated	1.0 m <sup>3</sup>	<b>1.31 yd<sup>3</sup></b>	1.03 m <sup>3</sup>	<b>1.34 yd<sup>3</sup></b>	1.03 m <sup>3</sup>
Width	2406 mm	<b>95"</b>	2406 mm	<b>95"</b>	2406 mm	<b>95"</b>
Lift capacity at maximum height	2823 kg	<b>6223 lb</b>	2640 kg	<b>5821 lb</b>	2518 kg	<b>5552 lb</b>
Lift breakout force	46.2 kN	<b>10,375 lbf</b>	44.9 kN	<b>10,085 lbf</b>	43.3 kN	<b>9742 lbf</b>
Tilt breakout force	49.0 kN	<b>11,017 lbf</b>	54.2 kN	<b>12,183 lbf</b>	53.3 kN	<b>11,978 lbf</b>
7) Maximum hinge pin height	3395 mm	<b>11'2"</b>	3395 mm	<b>11'2"</b>	3395 mm	<b>11'2"</b>
8) Dump angle at full height		<b>46°</b>		<b>46°</b>		<b>46°</b>
Dump height at maximum angle	2686 mm	<b>8'10"</b>	2711 mm	<b>8'11"</b>	2711 mm	<b>8'11"</b>
9) Dump reach at maximum angle	783 mm	<b>2'7"</b>	711 mm	<b>2'4"</b>	711 mm	<b>2'4"</b>
10) Maximum bucket rollback at ground level		<b>37°</b>		<b>38°</b>		<b>38°</b>
11) Digging depth	168 mm	<b>7"</b>	201 mm	<b>8"</b>	201 mm	<b>8"</b>
Maximum grading angle		<b>113°</b>		<b>115°</b>		<b>115°</b>
Width of dozer cutting edge		<b>N/A</b>	2406 mm	<b>7'11"</b>	2406 mm	<b>7'11"</b>
Grill to bucket cutting edge, carry position	1477 mm	<b>4'10"</b>	1438 mm	<b>4'9"</b>	1438 mm	<b>4'9"</b>
12) Maximum operating height	4293 mm	<b>14'1"</b>	4324 mm	<b>14'2"</b>	4324 mm	<b>14'2"</b>
Jaw opening maximum		<b>N/A</b>	790 mm	<b>2'7"</b>	790 mm	<b>2'7"</b>
Bucket jaw clamping force		<b>N/A</b>	62.2 kN	<b>13,988 lbf</b>	62.2 kN	<b>13,988 lbf</b>
Weight (does not include teeth or forks)	441 kg	<b>973 lb</b>	680 kg	<b>1499 lb</b>	851 kg	<b>1876 lb</b>

BACKHOE DIMENSIONS AND PERFORMANCE	Standard Stick		Extendible Stick Retracted		Extendible Stick Extended	
	13) Digging depth, manufacturers maximum	4843 mm	<b>15'11"</b>	4848 mm	<b>15'11"</b>	5765 mm
14) Digging depth, 610 mm (2'0") flat bottom	4199 mm	<b>13'9"</b>	4203 mm	<b>13'9"</b>	5202 mm	<b>17'1"</b>
15) Reach from swing pivot at ground line	5645 mm	<b>18'6"</b>	5650 mm	<b>18'6"</b>	6576 mm	<b>21'7"</b>
Loading height	4063 mm	<b>13'4"</b>	4071 mm	<b>13'4"</b>	4691 mm	<b>15'5"</b>
16) Loading reach	1613 mm	<b>5'4"</b>	1561 mm	<b>5'1"</b>	2408 mm	<b>7'11"</b>
Swing arc		<b>180°</b>		<b>180°</b>		<b>180°</b>
Bucket rotation		<b>205°</b>		<b>205°</b>		<b>205°</b>
17) Stabilizer width	2240 mm	<b>7'4"</b>	2240 mm	<b>7'4"</b>	2240 mm	<b>7'4"</b>
Bucket dig force	58.4 kN	<b>13,137 lbf</b>	58.4 kN	<b>13,131 lbf</b>	58.4 kN	<b>13,131 lbf</b>
Stick dig force	33.4 kN	<b>7514 lbf</b>	34.1 kN	<b>7674 lbf</b>	25.0 kN	<b>5625 lbf</b>
Total side shift travel	1096 mm	<b>3'7"</b>	1096 mm	<b>3'7"</b>	1096 mm	<b>3'7"</b>



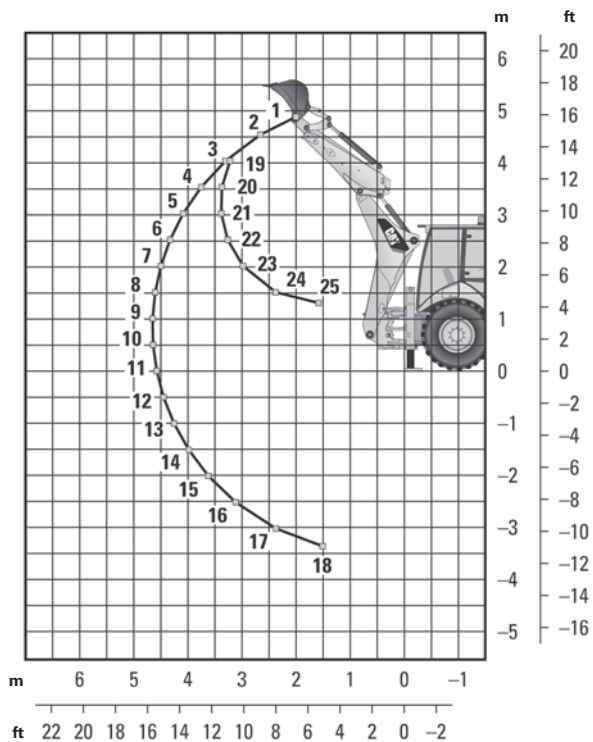

**Standard Stick**

Boom Lifting

1	1275 kg	<b>2806 lb</b>
2	1390 kg	<b>3058 lb</b>
3	1409 kg	<b>3100 lb</b>
4	1386 kg	<b>3048 lb</b>
5	1349 kg	<b>2969 lb</b>
6	1309 kg	<b>2881 lb</b>
7	1269 kg	<b>2792 lb</b>
8	1229 kg	<b>2705 lb</b>
9	1192 kg	<b>2622 lb</b>
10	1156 kg	<b>2543 lb</b>
11	1122 kg	<b>2469 lb</b>
12	1091 kg	<b>2400 lb</b>
13	1062 kg	<b>2336 lb</b>
14	1036 kg	<b>2279 lb</b>
15	1014 kg	<b>2230 lb</b>
16	999 kg	<b>2197 lb</b>
17	1003 kg	<b>2206 lb</b>
18	1077 kg	<b>2370 lb</b>

Stick Lifting

19	1989 kg	<b>4375 lb</b>
20	2186 kg	<b>4808 lb</b>
21	2171 kg	<b>4776 lb</b>
22	2265 kg	<b>4983 lb</b>
23	2532 kg	<b>5570 lb</b>
24	3369 kg	<b>7413 lb</b>
25	5150 kg	<b>11,330 lb</b>

Lift Capacities are over-end values. Machine equipped with 2WD, OROPS, 1.0 m<sup>3</sup> (1.3 yd<sup>3</sup>) general purpose bucket, and 240 kg (530 lb) counterweight.

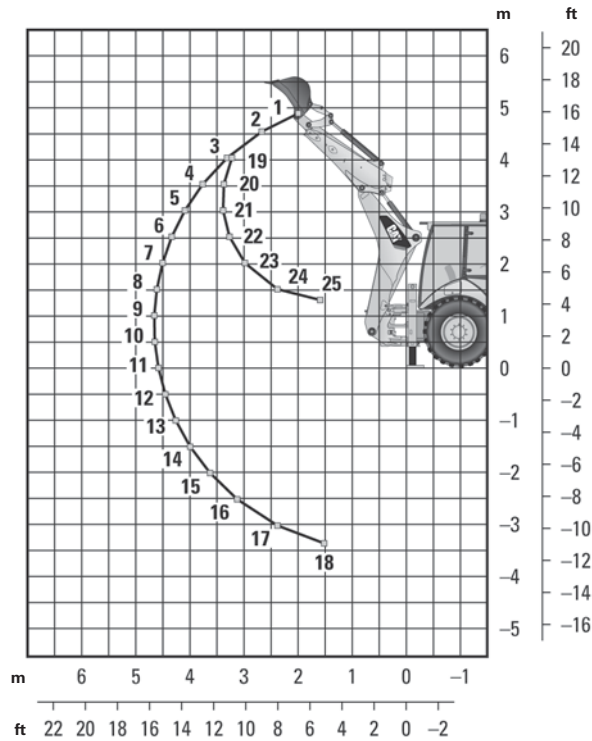

**Extendible Stick Retracted**

Boom Lifting

1	1196 kg	2630 lb
2	1282 kg	2820 lb
3	1282 kg	2821 lb
4	1249 kg	2748 lb
5	1206 kg	2653 lb
6	1161 kg	2554 lb
7	1116 kg	2455 lb
8	1073 kg	2360 lb
9	1031 kg	2269 lb
10	992 kg	2182 lb
11	954 kg	2100 lb
12	919 kg	2022 lb
13	886 kg	1949 lb
14	855 kg	1880 lb
15	826 kg	1816 lb
16	800 kg	1759 lb
17	781 kg	1718 lb
18	795 kg	1749 lb

Stick Lifting

19	1931 kg	4249 lb
20	2059 kg	4530 lb
21	2042 kg	4492 lb
22	2130 kg	4687 lb
23	2387 kg	5251 lb
24	3195 kg	7029 lb
25	4929 kg	10,843 lb

Lift Capacities are over-end values. Machine equipped with 2WD, OROPS, 1.0 m<sup>3</sup> (1.3 yd<sup>3</sup>) general purpose bucket, and 240 kg (530 lb) counterweight.

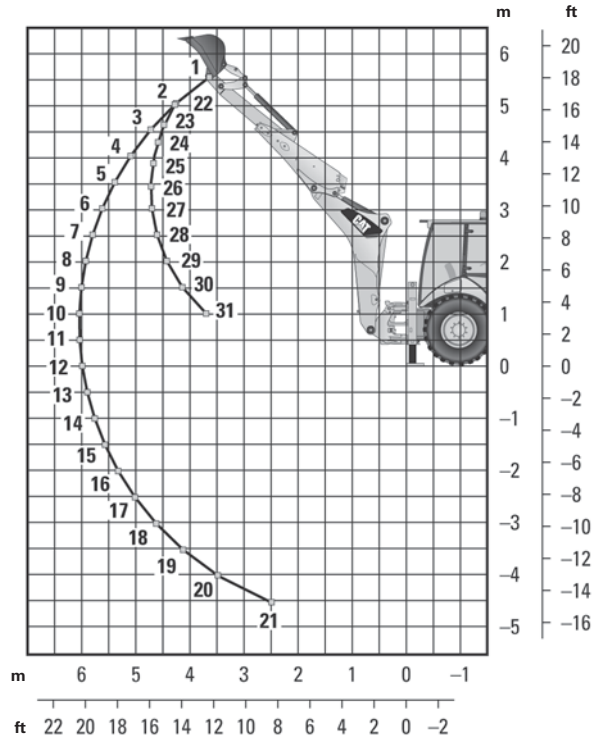

**Extendible Stick Extended**

Boom Lifting

1	683 kg	1503 lb
2	819 kg	1801 lb
3	872 kg	1919 lb
4	890 kg	1959 lb
5	892 kg	1962 lb
6	884 kg	1946 lb
7	872 kg	1919 lb
8	857 kg	1886 lb
9	841 kg	1850 lb
10	824 kg	1814 lb
11	808 kg	1777 lb
12	792 kg	1742 lb
13	776 kg	1708 lb
14	762 kg	1677 lb
15	750 kg	1650 lb
16	741 kg	1629 lb
17	735 kg	1616 lb
18	736 kg	1619 lb
19	752 kg	1654 lb
20	822 kg	1808 lb
21	1259 kg	2769 lb

Stick Lifting

22	1003 kg	2207 lb
23	1211 kg	2665 lb
24	1373 kg	3021 lb
25	1450 kg	3189 lb
26	1479 kg	3254 lb
27	1553 kg	3416 lb
28	1694 kg	3727 lb
29	1971 kg	4336 lb
30	2724 kg	5993 lb
31	5505 kg	12,112 lb

Lift Capacities are over-end values. Machine equipped with 2WD, OROPS, 1.0 m<sup>3</sup> (1.3 yd<sup>3</sup>) general purpose bucket, and 240 kg (530 lb) counterweight.

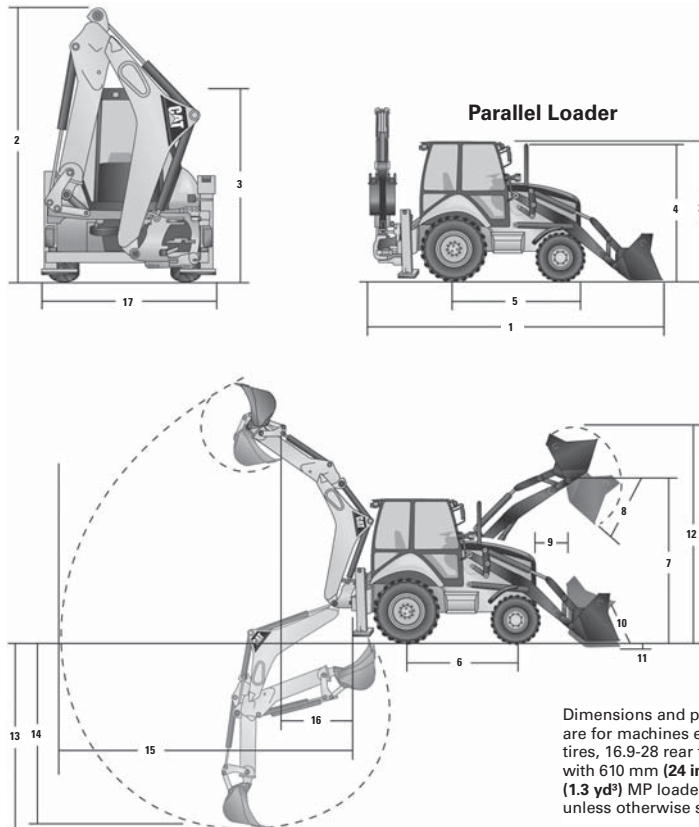

Dimensions and performance specifications shown are for machines equipped with 12.5/80-18 front tires, 16.9-28 rear tires, standard cab, standard stick with 610 mm (24 in) standard duty bucket, and 1.0 m<sup>3</sup> (1.3 yd<sup>3</sup>) MP loader bucket and standard equipment unless otherwise specified.

MACHINE DIMENSIONS	Standard Frame					
	General Purpose 1.0 m <sup>3</sup> (1.31 yd <sup>3</sup> )		Multi Purpose 1.03 m <sup>3</sup> (1.35 yd <sup>3</sup> )		Multi Purpose with Forks 1.03 m <sup>3</sup> (1.35 yd <sup>3</sup> )	
1) Overall length (loader on ground)	7398 mm	24'3"	7353 mm	24'1"	7353 mm	24'1"
Overall transport length	5750 mm	18'10"	5704 mm	18'9"	5704 mm	18'9"
2) Overall transport height S-Stick	3779 mm	12'5"	3791 mm	12'5"	3791 mm	12'5"
Overall transport height E-Stick	3771 mm	12'4"	3771 mm	12'4"	3771 mm	12'4"
Overall width (Standard)	2352 mm	7'9"	2352 mm	7'9"	2352 mm	7'9"
Overall width (Narrow)	2352 mm	7'9"	2352 mm	7'9"	2352 mm	7'9"
3) Height to top of cab/canopy	2897 mm	9'6"	2897 mm	9'6"	2897 mm	9'6"
4) Height to top of exhaust stack	2744 mm	9'0"	2744 mm	9'0"	2744 mm	9'0"
Height to loader hinge pin (transport)	361 mm	1'2"	318 mm	1'1"	318 mm	1'1"
Ground clearance (stabilizer feet)	336 mm	1'1"	336 mm	1'1"	336 mm	1'1"
Ground clearance (LH step)	323 mm	1'1"	323 mm	1'1"	323 mm	1'1"
Ground clearance (AWD guard)	318 mm	1'1"	318 mm	1'1"	318 mm	1'1"
Ground clearance (485 kg/1170 lb counterweight)	287 mm	11"	287 mm	11"	287 mm	11"
5) Rear axle centerline to front grill	2705 mm	8'10"	2705 mm	8'10"	2705 mm	8'10"
Front wheel tread gauge	1895 mm	6'3"	1895 mm	6'3"	1895 mm	6'3"
Rear wheel tread gauge	1714 mm	5'7"	1714 mm	5'7"	1714 mm	5'7"
6) Wheelbase (AWD)	2200 mm	7'3"	2200 mm	7'3"	2200 mm	7'3"

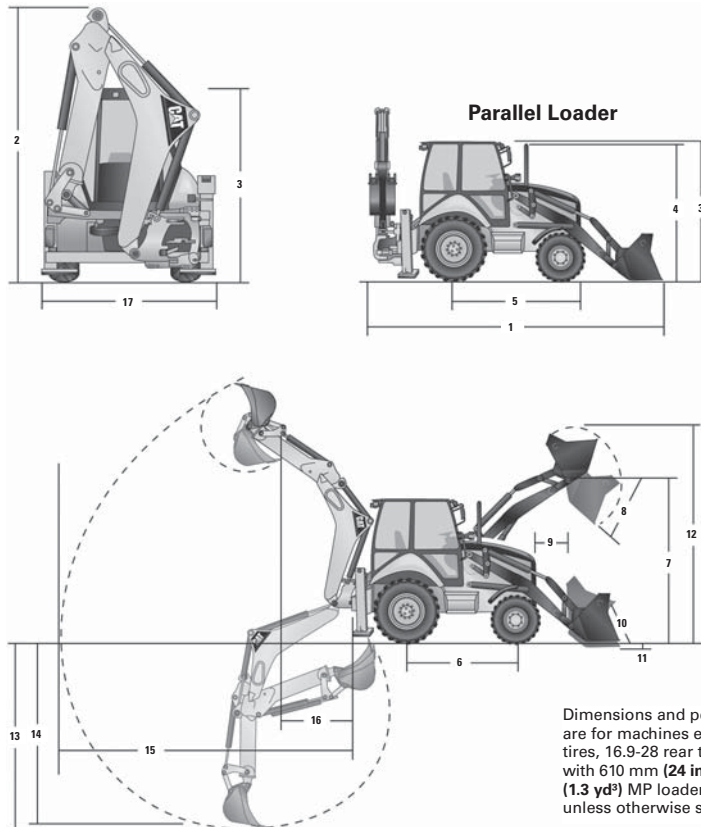

Dimensions and performance specifications shown are for machines equipped with 12.5/80-18 front tires, 16.9-28 rear tires, standard cab, standard stick with 610 mm (24 in) standard duty bucket, and 1.0 m<sup>3</sup> (1.3 yd<sup>3</sup>) MP loader bucket and standard equipment unless otherwise specified.

MACHINE DIMENSIONS	Narrow Frame	
	Multi Purpose 0.96 m <sup>3</sup> (1.25 yd <sup>3</sup> )	
1) Overall length (loader on ground)	7353 mm	24'1"
Overall transport length	5704 mm	18'9"
2) Overall transport height S-Stick	3779 mm	12'5"
Overall transport height E-Stick	3771 mm	12'4"
Overall width (Standard)	2352 mm	7'9"
Overall width (Narrow)	2352 mm	7'9"
3) Height to top of cab/canopy	2897 mm	9'6"
4) Height to top of exhaust stack	2744 mm	9'0"
Height to loader hinge pin (transport)	318 mm	1'1"
Ground clearance (stabilizer feet)	336 mm	1'1"
Ground clearance (LH step)	323 mm	1'1"
Ground clearance (AWD guard)	318 mm	1'1"
Ground clearance (485 kg/1170 lb counterweight)	287 mm	11"
5) Rear axle centerline to front grill	2705 mm	8'10"
Front wheel tread gauge	1895 mm	6'3"
Rear wheel tread gauge	1714 mm	5'7"
6) Wheelbase (AWD)	2200 mm	7'3"

LOADER BUCKET DIMENSIONS AND PERFORMANCE	Standard Frame					
	General Purpose 1.0 m <sup>3</sup> (1.31 yd <sup>3</sup> )		Multi Purpose 1.03 m <sup>3</sup> (1.35 yd <sup>3</sup> )		Multi Purpose with Forks 1.03 m <sup>3</sup> (1.35 yd <sup>3</sup> )	
Capacity (SAE) rated	1.0 m <sup>3</sup>	1.31 yd <sup>3</sup>	1.03 m <sup>3</sup>	1.35 yd <sup>3</sup>	1.03 m <sup>3</sup>	1.35 yd <sup>3</sup>
Width	2406 mm	95"	2406 mm	95"	2406 mm	95"
Lift capacity at maximum height	3817 kg	8415 lb	3580 kg	3402 lb	3402 kg	7500 lb
Lift breakout force	54.8 kN	12,324 lbf	53.3 kN	11,993 lbf	51.7 kN	11,623 lbf
Tilt breakout force	54.8 kN	12,330 lbf	60.3 kN	13,561 lbf	59.4 kN	13,354 lbf
7) Maximum hinge pin height	3497 mm	11'6"	3497 mm	11'6"	3497 mm	11'6"
8) Dump angle at full height		45°		45°		45°
Dump height at maximum angle	2796 mm	9'2"	2823 mm	9'3"	2823 mm	9'3"
9) Dump reach at maximum angle	805 mm	2'8"	731 mm	2'5"	731 mm	2'5"
10) Maximum bucket rollback at ground level		38°		39°		39°
11) Digging depth	61 mm	2"	94 mm	4"	94 mm	4"
Maximum grading angle		114°		116°		116°
Width of dozer cutting edge		N/A		N/A		N/A
Grill to bucket cutting edge, carry position	1467 mm	4'10"	1419 mm	4'8"	1419 mm	4'8"
12) Maximum operating height	4394 mm	14'5"	4427 mm	14'6"	4883 mm	16'0"
Jaw opening maximum		N/A	790 mm	2'7"	790 mm	2'7"
Bucket jaw clamping force		N/A	61 kN	13,699 lbf	61 kN	13,699 lbf
Weight (does not include teeth or forks)	428 kg	942 lb	611 kg	1347 lb	705 kg	1554 lb

LOADER BUCKET DIMENSIONS AND PERFORMANCE	Narrow Frame	
	Multi Purpose 0.96 m <sup>3</sup> (1.25 yd <sup>3</sup> )	
Capacity (SAE) rated	0.96 m <sup>3</sup>	1.25 yd <sup>3</sup>
Width	2262 mm	89"
Lift capacity at maximum height	3592 kg	7919 lb
Lift breakout force	53.5 kN	12,018 lbf
Tilt breakout force	60.4 kN	13,588 lbf
7) Maximum hinge pin height	3497 mm	11'6"
8) Dump angle at full height		45°
Dump height at maximum angle	2823 mm	9'3"
9) Dump reach at maximum angle	731 mm	2'5"
10) Maximum bucket rollback at ground level		39°
11) Digging depth	94 mm	4"
Maximum grading angle		116°
Width of dozer cutting edge		N/A
Grill to bucket cutting edge, carry position	1419 mm	4'8"
12) Maximum operating height	4396 mm	14'5"
Jaw opening maximum	790 mm	2'7"
Bucket jaw clamping force	61 kN	13,699 lbf
Weight (does not include teeth or forks)	842 kg	1856 lb

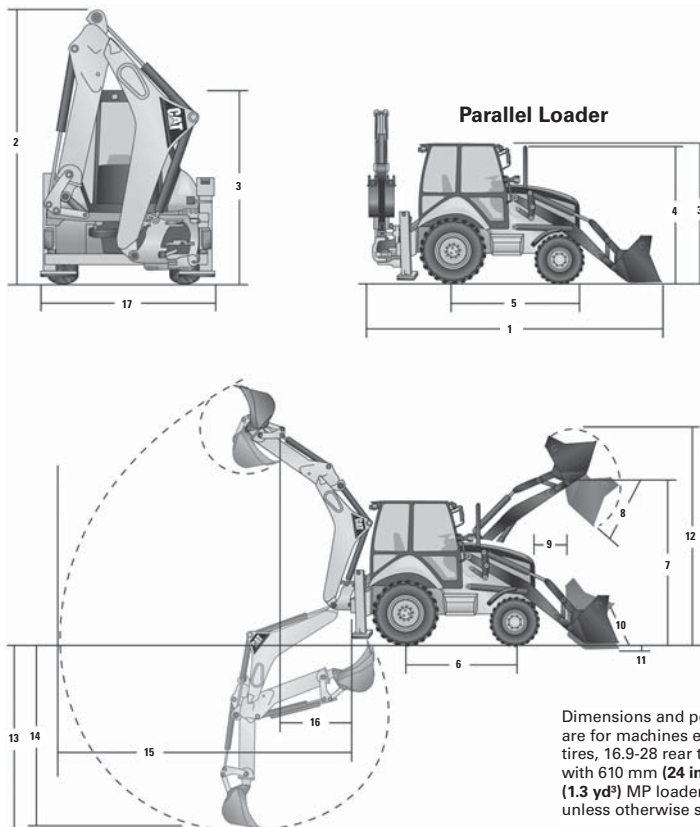

Dimensions and performance specifications shown are for machines equipped with 12.5/80-18 front tires, 16.9-28 rear tires, standard cab, standard stick with 610 mm (24 in) standard duty bucket, and 1.0 m<sup>3</sup> (1.3 yd<sup>3</sup>) MP loader bucket and standard equipment unless otherwise specified.

BACKHOE DIMENSIONS AND PERFORMANCE	Standard Stick		Extendible Stick Retracted		Extendible Stick Extended	
	13) Digging depth, manufacturers maximum	4775 mm	14'8"	4778 mm	15'8"	5696 mm
14) Digging depth, 610 mm (2'0") flat bottom	4235 mm	13'11"	4239 mm	13'11"	5235 mm	17'2"
15) Reach from swing pivot at ground line	5650 mm	18'6"	5655 mm	18'7"	6581 mm	21'7"
Loading height	4016 mm	13'2"	4025 mm	13'2"	4630 mm	15'2"
16) Loading reach	1669 mm	5'6"	1617 mm	5'4"	2475 mm	8'1"
Swing arc	180°		180°		180°	
Bucket rotation	205°		205°		205°	
17) Stabilizer width	2352 mm	7'9"	2352 mm	7'9"	2352 mm	7'9"
Bucket dig force	63.5 kN	14,264 lbf	63.4 kN	14,258 lbf	63.4 kN	14,258 lbf
Stick dig force	36.2 kN	8132 lbf	36.9 kN	8295 lbf	27.0 kN	6066 lbf
Total side shift travel (Standard frame)	1258 mm	4'2"	1258 mm	4'2"	1258 mm	4'2"
Total side shift travel (Narrow frame)	1096 mm	3'7"	1096 mm	3'7"	1096 mm	3'7"

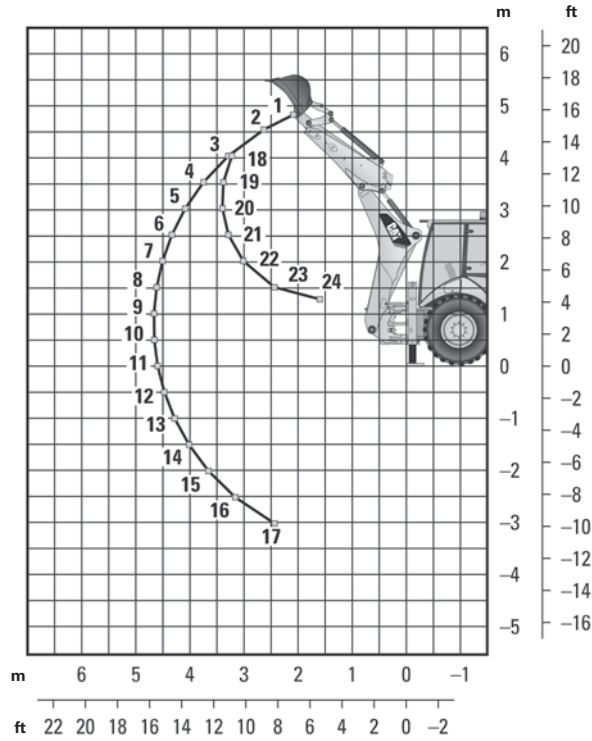

**Standard Stick**

Boom Lifting

1	1317 kg	2897 lb
2	1459 kg	3210 lb
3	1514 kg	3331 lb
4	1506 kg	3313 lb
5	1478 kg	3251 lb
6	1442 kg	3173 lb
7	1404 kg	3089 lb
8	1366 kg	3006 lb
9	1330 kg	2925 lb
10	1295 kg	2849 lb
11	1262 kg	2777 lb
12	1232 kg	2711 lb
13	1205 kg	2652 lb
14	1182 kg	2601 lb
15	1165 kg	2563 lb
16	1158 kg	2549 lb
17	1184 kg	2604 lb

Stick Lifting

18	2150 kg	4730 lb
19	2131 kg	4688 lb
20	2113 kg	4648 lb
21	2200 kg	4839 lb
22	2450 kg	5391 lb
23	3219 kg	7082 lb
24	5708 kg	12,558 lb

Lift Capacities are over-end values. Machine equipped with AWD, standard cab, 1.0 m<sup>3</sup> (1.31 yd<sup>3</sup>) multi-purpose bucket, and no counterweight.



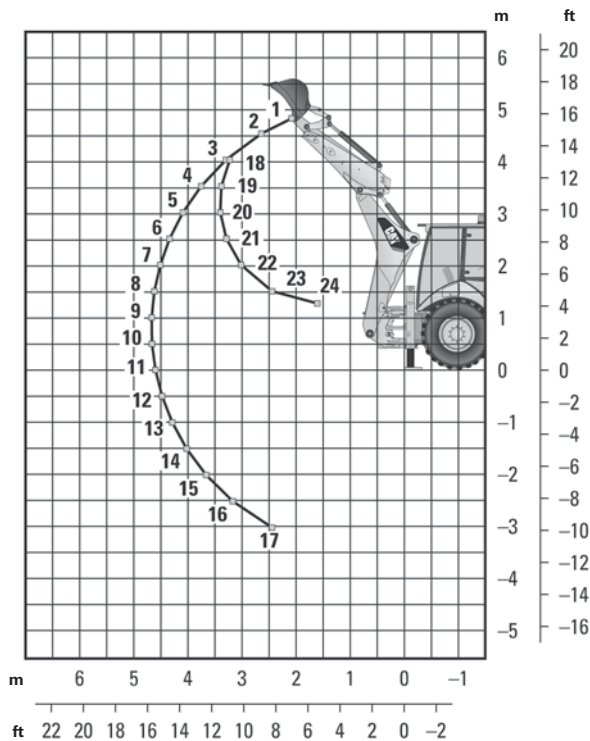

**Extendible Stick Retracted – 4264 mm (14'0")**

Boom Lifting

1	1234 kg	2714 lb
2	1353 kg	2977 lb
3	1388 kg	3054 lb
4	1370 kg	3013 lb
5	1335 kg	2936 lb
6	1294 kg	2846 lb
7	1251 kg	2753 lb
8	1210 kg	2661 lb
9	1169 kg	2572 lb
10	1131 kg	2488 lb
11	1095 kg	2408 lb
12	1061 kg	2333 lb
13	1029 kg	2264 lb
14	1001 kg	2202 lb
15	977 kg	2149 lb
16	959 kg	2111 lb
17	962 kg	2117 lb

Stick Lifting

18	2094 kg	4608 lb
19	2005 kg	4410 lb
20	1984 kg	4364 lb
21	2066 kg	4544 lb
22	2306 kg	5074 lb
23	3047 kg	6704 lb
24	5429 kg	11,945 lb

Lift Capacities are over-end values. Machine equipped with AWD, standard cab, 1.0 m<sup>3</sup> (1.31 yd<sup>3</sup>) multi-purpose bucket, and no counterweight.

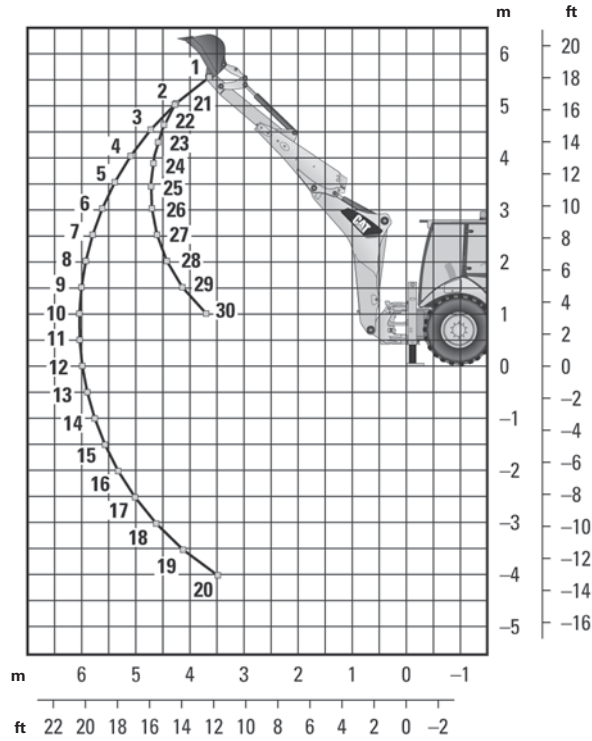

**Extendible Stick Extended – 4264 mm (14'0")**

Boom Lifting

1	720 kg	1585 lb
2	867 kg	1908 lb
3	944 kg	2077 lb
4	975 kg	2146 lb
5	985 kg	2168 lb
6	984 kg	2164 lb
7	976 kg	2147 lb
8	964 kg	2121 lb
9	950 kg	2091 lb
10	936 kg	2059 lb
11	921 kg	2026 lb
12	907 kg	1994 lb
13	893 kg	1965 lb
14	881 kg	1939 lb
15	872 kg	1917 lb
16	865 kg	1903 lb
17	864 kg	1900 lb
18	872 kg	1918 lb
19	900 kg	1979 lb
20	998 kg	2195 lb

Stick Lifting

21	1109 kg	2440 lb
22	1328 kg	2922 lb
23	1417 kg	3118 lb
24	1409 kg	3101 lb
25	1437 kg	3161 lb
26	1507 kg	3315 lb
27	1641 kg	3611 lb
28	1905 kg	4190 lb
29	2603 kg	5727 lb
30	6145 kg	13,519 lb

Lift Capacities are over-end values. Machine equipped with AWD, standard cab, 1.0 m<sup>3</sup> (1.31 yd<sup>3</sup>) multi-purpose bucket, and no counterweight.

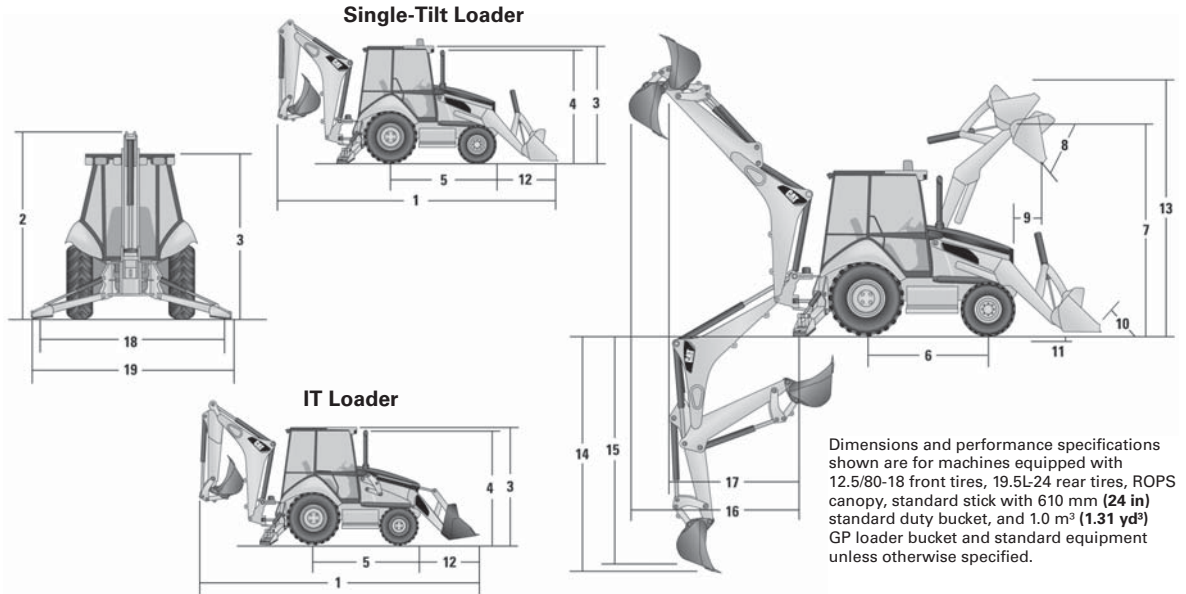

MACHINE DIMENSIONS	Single-Tilt Loader							
	General Purpose 0.96 m <sup>3</sup> (1.25 yd <sup>3</sup> )		General Purpose 1.0 m <sup>3</sup> (1.31 yd <sup>3</sup> )		General Purpose 1.07 m <sup>3</sup> (1.4 yd <sup>3</sup> )		General Purpose 1.15 m <sup>3</sup> (1.5 yd <sup>3</sup> )	
1) Overall transport length	7310 mm	24'0"	7277 mm	23'10"	7349 mm	24'1"	7349 mm	24'1"
Overall length	7282 mm	23'11"	7237 mm	23'9"	7302 mm	23'11"	7302 mm	23'11"
2) Overall transport height S-stick	3577 mm	11'9"	3577 mm	11'9"	3577 mm	11'9"	3577 mm	11'9"
Overall transport height E-stick	3631 mm	11'11"	3631 mm	11'11"	3631 mm	11'11"	3631 mm	11'11"
Overall width	2322 mm	7'7"	2322 mm	7'7"	2322 mm	7'7"	2322 mm	7'7"
3) Height to top of cab/canopy	2819 mm	9'3"	2819 mm	9'3"	2819 mm	9'3"	2819 mm	9'3"
4) Height to top of exhaust stack	2744 mm	9'0"	2744 mm	9'0"	2744 mm	9'0"	2744 mm	9'0"
Ground clearance (LH step)	294 mm	1'0"	294 mm	1'0"	294 mm	1'0"	294 mm	1'0"
Ground clearance (AWD guard)	294 mm	1'0"	294 mm	1'0"	294 mm	1'0"	294 mm	1'0"
Ground clearance (485 kg/ 1170 lb counterweight)	274 mm	11"	274 mm	11"	274 mm	11"	274 mm	11"
5) Rear axle centerline to front grill	2705 mm	8'10"	2705 mm	8'10"	2705 mm	8'10"	2705 mm	8'10"
Front wheel tread gauge	1895 mm	6'3"	1895 mm	6'3"	1895 mm	6'3"	1895 mm	6'3"
Rear wheel tread gauge	1714 mm	5'7"	1714 mm	5'7"	1714 mm	5'7"	1714 mm	5'7"
6) Wheelbase (2WD/AWD)	2200 mm	7'3"	2200 mm	7'3"	2200 mm	7'3"	2200 mm	7'3"

MACHINE DIMENSIONS	Single-Tilt Loader							
	Multi Purpose 1.0 m <sup>3</sup> (1.31 yd <sup>3</sup> )		Multi Purpose 1.07 m <sup>3</sup> (1.4 yd <sup>3</sup> )		Multi Purpose with Forks 1.0 m <sup>3</sup> (1.31 yd <sup>3</sup> )		Multi Purpose with Forks 1.07 m <sup>3</sup> (1.4 yd <sup>3</sup> )	
1) Overall transport length	7274 mm	23'10"	7274 mm	23'10"	7274 mm	23'10"	7274 mm	23'10"
Overall length	7200 mm	23'7"	7200 mm	23'7"	7200 mm	23'7"	7200 mm	23'7"
2) Overall transport height S-stick	3577 mm	11'9"	3577 mm	11'9"	3577 mm	11'9"	3577 mm	11'9"
Overall transport height E-stick	3631 mm	11'11"	3631 mm	11'11"	3631 mm	11'11"	3631 mm	11'11"
Overall width	2322 mm	7'7"	2322 mm	7'7"	2322 mm	7'7"	2322 mm	7'7"
3) Height to top of cab/canopy	2819 mm	9'3"	2819 mm	9'3"	2819 mm	9'3"	2819 mm	9'3"
4) Height to top of exhaust stack	2744 mm	9'0"	2744 mm	9'0"	2744 mm	9'0"	2744 mm	9'0"
Ground clearance (LH step)	294 mm	1'0"	294 mm	1'0"	294 mm	1'0"	294 mm	1'0"
Ground clearance (AWD guard)	294 mm	1'0"	294 mm	1'0"	294 mm	1'0"	294 mm	1'0"
Ground clearance (485 kg/ 1170 lb counterweight)	274 mm	11"	274 mm	11"	274 mm	11"	274 mm	11"
5) Rear axle centerline to front grill	2705 mm	8'10"	2705 mm	8'10"	2705 mm	8'10"	2705 mm	8'10"
Front wheel tread gauge	1895 mm	6'3"	1895 mm	6'3"	1895 mm	6'3"	1895 mm	6'3"
Rear wheel tread gauge	1714 mm	5'7"	1714 mm	5'7"	1714 mm	5'7"	1714 mm	5'7"
6) Wheelbase (2WD/AWD)	2200 mm	7'3"	2200 mm	7'3"	2200 mm	7'3"	2200 mm	7'3"

MACHINE DIMENSIONS	IT Loader with Quick Coupler					
	General Purpose 0.96 m <sup>3</sup> (1.25 yd <sup>3</sup> )		General Purpose 1.0 m <sup>3</sup> (1.31 yd <sup>3</sup> )		General Purpose 1.15 m <sup>3</sup> (1.5 yd <sup>3</sup> )	
1) Overall transport length	7423 mm	24'4"	7391 mm	24'3"	7420 mm	24'4"
Overall length	7430 mm	24'5"	7385 mm	24'3"	7428 mm	24'4"
2) Overall transport height S-stick	3577 mm	11'9"	3577 mm	11'9"	3577 mm	11'9"
Overall transport height E-stick	3631 mm	11'11"	3631 mm	11'11"	3631 mm	11'11"
Overall width	2322 mm	7'7"	2322 mm	7'7"	2322 mm	7'7"
3) Height to top of cab/canopy	2819 mm	9'3"	2819 mm	9'3"	2819 mm	9'3"
4) Height to top of exhaust stack	2744 mm	9'0"	2744 mm	9'0"	2744 mm	9'0"
Ground clearance (LH step)	294 mm	1'0"	294 mm	1'0"	294 mm	1'0"
Ground clearance (AWD guard)	294 mm	1'0"	294 mm	1'0"	294 mm	1'0"
Ground clearance (485 kg/ 1170 lb counterweight)	274 mm	11"	274 mm	11"	274 mm	11"
5) Rear axle centerline to front grill	2705 mm	8'10"	2705 mm	8'10"	2705 mm	8'10"
Front wheel tread gauge	1895 mm	6'3"	1895 mm	6'3"	1895 mm	6'3"
Rear wheel tread gauge	1714 mm	5'7"	1714 mm	5'7"	1714 mm	5'7"
6) Wheelbase (2WD/AWD)	2200 mm	7'3"	2200 mm	7'3"	2200 mm	7'3"

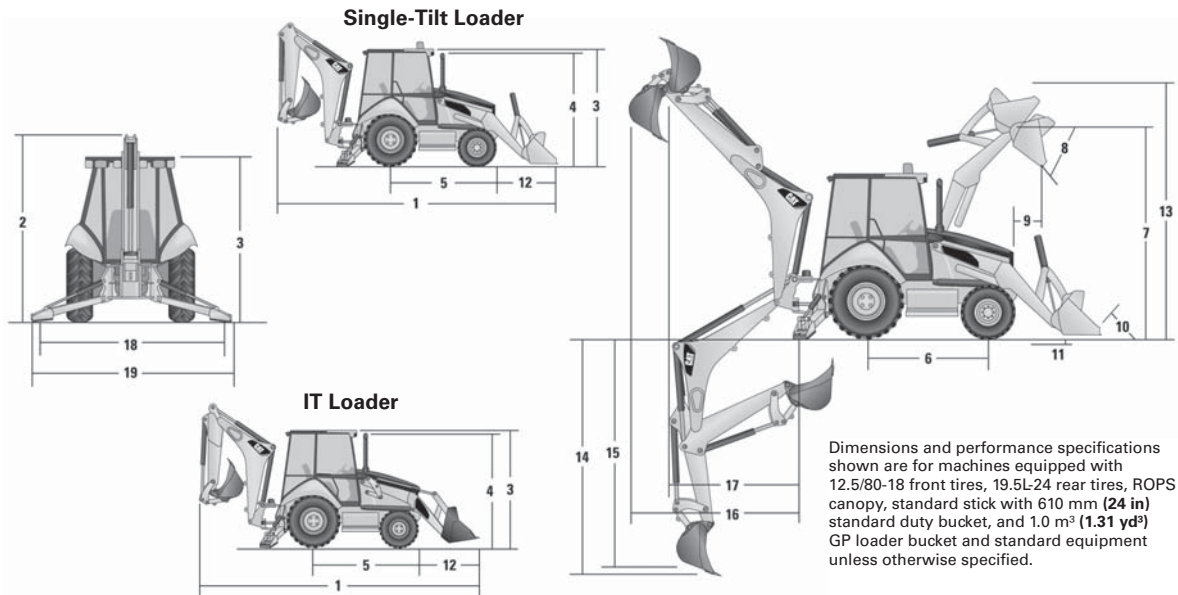

Dimensions and performance specifications shown are for machines equipped with 12.5/80-18 front tires, 19.5L-24 rear tires, ROPS canopy, standard stick with 610 mm (24 in) standard duty bucket, and 1.0 m<sup>3</sup> (1.31 yd<sup>3</sup>) GP loader bucket and standard equipment unless otherwise specified.

MACHINE DIMENSIONS	IT Loader with Quick Coupler			
	Multi Purpose 0.96 m <sup>3</sup> (1.25 yd <sup>3</sup> )		Multi Purpose 1.03 m <sup>3</sup> (1.35 yd <sup>3</sup> )	
	mm	ft"	mm	ft"
1) Overall transport length	7352 mm	24'1"	7352 mm	24'1"
Overall length	7338 mm	24'1"	7338 mm	24'1"
2) Overall transport height S-stick	3577 mm	11'9"	3577 mm	11'9"
Overall transport height E-stick	3631 mm	11'11"	3631 mm	11'11"
Overall width	2322 mm	7'7"	2322 mm	7'7"
3) Height to top of cab/canopy	2819 mm	9'3"	2819 mm	9'3"
4) Height to top of exhaust stack	2744 mm	9'0"	2744 mm	9'0"
Ground clearance (LH step)	294 mm	1'0"	294 mm	1'0"
Ground clearance (AWD guard)	294 mm	1'0"	294 mm	1'0"
Ground clearance (485 kg/ 1170 lb counterweight)	274 mm	11"	274 mm	11"
5) Rear axle centerline to front grill	2705 mm	8'10"	2705 mm	8'10"
Front wheel tread gauge	1895 mm	6'3"	1895 mm	6'3"
Rear wheel tread gauge	1714 mm	5'7"	1714 mm	5'7"
6) Wheelbase (2WD/AWD)	2200 mm	7'3"	2200 mm	7'3"

LOADER BUCKET DIMENSIONS AND PERFORMANCE	Single-Tilt Loader							
	General Purpose 0.96 m <sup>3</sup> (1.25 yd <sup>3</sup> )		General Purpose 1.0 m <sup>3</sup> (1.31 yd <sup>3</sup> )		General Purpose 1.07 m <sup>3</sup> (1.4 yd <sup>3</sup> )		General Purpose 1.15 m <sup>3</sup> (1.5 yd <sup>3</sup> )	
Capacity (SAE) rated	0.96 m <sup>3</sup>	<b>1.25 yd<sup>3</sup></b>	1.0 m <sup>3</sup>	<b>1.31 yd<sup>3</sup></b>	1.07 m <sup>3</sup>	<b>1.4 yd<sup>3</sup></b>	1.15 m <sup>3</sup>	<b>1.5 yd<sup>3</sup></b>
Width	2262 mm	<b>89"</b>	2406 mm	<b>95"</b>	2262 mm	<b>89"</b>	2406 mm	<b>95"</b>
Lift capacity at maximum height	3283 kg	<b>7237 lb</b>	3292 kg	<b>7257 lb</b>	3216 kg	<b>7090 lb</b>	3196 kg	<b>7046 lb</b>
Lift breakout force	49.8 kN	<b>11,197 lbf</b>	50.6 kN	<b>11,367 lbf</b>	49.3 kN	<b>11,077 lbf</b>	49.1 kN	<b>11,037 lbf</b>
Tilt breakout force	50.2 kN	<b>11,283 lbf</b>	53.4 kN	<b>11,995 lbf</b>	51.2 kN	<b>11,518 lbf</b>	51.1 kN	<b>11,494 lbf</b>
7) Maximum hinge pin height	3474 mm	<b>11'5"</b>	3474 mm	<b>11'5"</b>	3474 mm	<b>11'5"</b>	3474 mm	<b>11'5"</b>
8) Dump angle at full height		<b>44°</b>		<b>44°</b>		<b>44°</b>		<b>44°</b>
Dump height at maximum angle	2746 mm	<b>9'0"</b>	2777 mm	<b>9'1"</b>	2723 mm	<b>8'11"</b>	2723 mm	<b>8'11"</b>
9) Dump reach at maximum angle	808 mm	<b>2'8"</b>	775 mm	<b>2'7"</b>	773 mm	<b>2'6"</b>	773 mm	<b>2'6"</b>
10) Maximum bucket rollback at ground level		<b>37°</b>		<b>37°</b>		<b>38°</b>		<b>39°</b>
11) Digging depth	83 mm	<b>3"</b>	83 mm	<b>3"</b>	123 mm	<b>5"</b>	123 mm	<b>5"</b>
Maximum grading angle		<b>112°</b>		<b>114°</b>		<b>113°</b>		<b>113°</b>
Width of dozer cutting edge		<b>N/A</b>		<b>N/A</b>		<b>N/A</b>		<b>N/A</b>
12) Grill to bucket cutting edge, carry position	1487 mm	<b>4'11"</b>	1454 mm	<b>4'9"</b>	1525 mm	<b>5'0"</b>	1525 mm	<b>5'0"</b>
13) Maximum operating height	4355 mm	<b>14'3"</b>	4353 mm	<b>14'3"</b>	4395 mm	<b>14'5"</b>	4395 mm	<b>14'5"</b>
Jaw opening maximum		<b>N/A</b>		<b>N/A</b>		<b>N/A</b>		<b>N/A</b>
Bucket jaw clamping force		<b>N/A</b>		<b>N/A</b>		<b>N/A</b>		<b>N/A</b>
Weight (does not include teeth or forks)	451 kg	<b>994 lb</b>	462 kg	<b>1019 lb</b>	473 kg	<b>1043 lb</b>	493 kg	<b>1087 lb</b>

LOADER BUCKET DIMENSIONS AND PERFORMANCE	Single-Tilt Loader							
	Multi Purpose 1.0 m <sup>3</sup> (1.31 yd <sup>3</sup> )		Multi Purpose 1.07 m <sup>3</sup> (1.4 yd <sup>3</sup> )		Multi Purpose with Forks 1.0 m <sup>3</sup> (1.31 yd <sup>3</sup> )		Multi Purpose with Forks 1.07 m <sup>3</sup> (1.4 yd <sup>3</sup> )	
Capacity (SAE) rated	1.0 m <sup>3</sup>	<b>1.31 yd<sup>3</sup></b>	1.07 m <sup>3</sup>	<b>1.4 yd<sup>3</sup></b>	1.0 m <sup>3</sup>	<b>1.31 yd<sup>3</sup></b>	1.07 m <sup>3</sup>	<b>1.4 yd<sup>3</sup></b>
Width	2279 mm	<b>90"</b>	2425 mm	<b>95"</b>	2279 mm	<b>90"</b>	2425 mm	<b>95"</b>
Lift capacity at maximum height	3097 kg	<b>6828 lb</b>	3068 kg	<b>6764 lb</b>	2982 kg	<b>6575 lb</b>	2953 kg	<b>6511 lb</b>
Lift breakout force	49.0 kN	<b>11,020 lbf</b>	48.8 kN	<b>10,964 lbf</b>	47.5 kN	<b>10,685 lbf</b>	47.3 kN	<b>10,629 lbf</b>
Tilt breakout force	57.6 kN	<b>12,938 lbf</b>	57.4 kN	<b>12,905 lbf</b>	56.6 kN	<b>12,733 lbf</b>	56.5 kN	<b>12,700 lbf</b>
7) Maximum hinge pin height	3474 mm	<b>11'5"</b>	3474 mm	<b>11'5"</b>	3474 mm	<b>11'5"</b>	3474 mm	<b>11'5"</b>
8) Dump angle at full height		<b>44°</b>		<b>44°</b>		<b>44°</b>		<b>44°</b>
Dump height at maximum angle	2798 mm	<b>9'2"</b>	2798 mm	<b>9'2"</b>	2798 mm	<b>9'2"</b>	2798 mm	<b>9'2"</b>
9) Dump reach at maximum angle	716 mm	<b>2'4"</b>	716 mm	<b>2'4"</b>	716 mm	<b>2'4"</b>	716 mm	<b>2'4"</b>
10) Maximum bucket rollback at ground level		<b>38°</b>		<b>38°</b>		<b>38°</b>		<b>38°</b>
11) Digging depth	110 mm	<b>4"</b>	110 mm	<b>4"</b>	110 mm	<b>4"</b>	110 mm	<b>4"</b>
Maximum grading angle		<b>116°</b>		<b>116°</b>		<b>116°</b>		<b>116°</b>
Width of dozer cutting edge	2262 mm	<b>7'5"</b>	2406 mm	<b>7'11"</b>	2262 mm	<b>7'5"</b>	2406 mm	<b>7'11"</b>
12) Grill to bucket cutting edge, carry position	1451 mm	<b>4'9"</b>	1451 mm	<b>4'9"</b>	1451 mm	<b>4'9"</b>	1451 mm	<b>4'9"</b>
13) Maximum operating height	4404 mm	<b>14'5"</b>	4404 mm	<b>14'5"</b>	4878 mm	<b>16'0"</b>	4878 mm	<b>16'0"</b>
Jaw opening maximum	790 mm	<b>2'7"</b>	790 mm	<b>2'7"</b>	790 mm	<b>2'7"</b>	790 mm	<b>2'7"</b>
Bucket jaw clamping force	55.7 kN	<b>12,521 lbf</b>	55.7 kN	<b>12,521 lbf</b>	55.7 kN	<b>12,521 lbf</b>	55.7 kN	<b>12,521 lbf</b>
Weight (does not include teeth or forks)	745 kg	<b>1642 lb</b>	774 kg	<b>1706 lb</b>	915 kg	<b>2017 lb</b>	936 kg	<b>2064 lb</b>

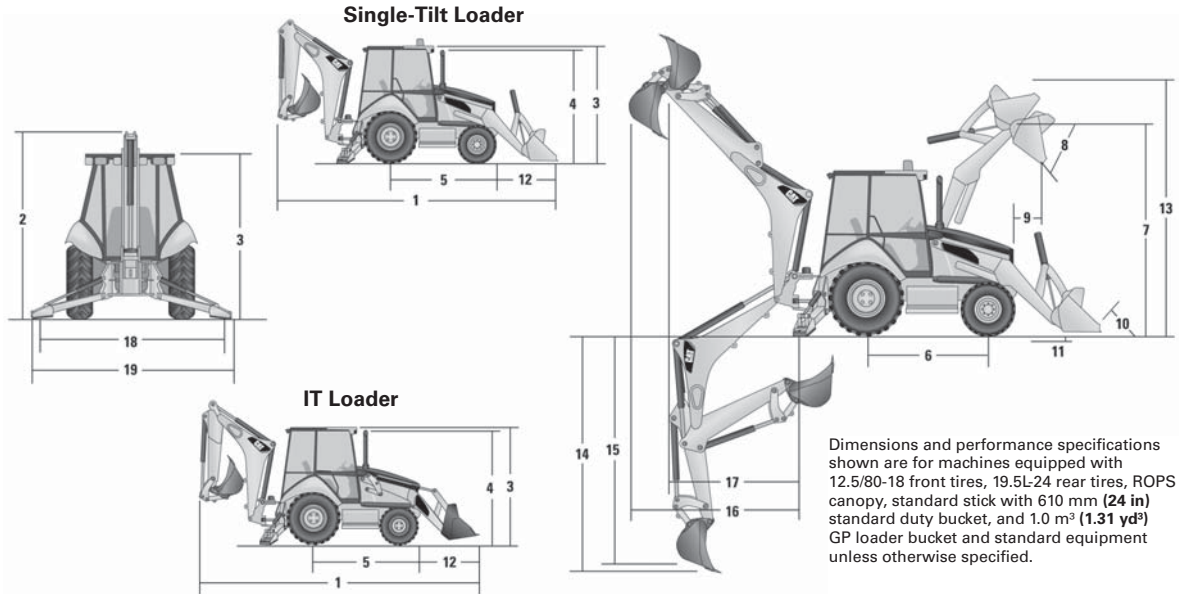

Dimensions and performance specifications shown are for machines equipped with 12.5/80-18 front tires, 19.5L-24 rear tires, ROPS canopy, standard stick with 610 mm (24 in) standard duty bucket, and 1.0 m<sup>3</sup> (1.31 yd<sup>3</sup>) GP loader bucket and standard equipment unless otherwise specified.

LOADER BUCKET DIMENSIONS AND PERFORMANCE	IT Loader with Quick Coupler					
	General Purpose 0.96 m <sup>3</sup> (1.25 yd <sup>3</sup> )		General Purpose 1.0 m <sup>3</sup> (1.31 yd <sup>3</sup> )		General Purpose 1.15 m <sup>3</sup> (1.5 yd <sup>3</sup> )	
Capacity (SAE) rated	0.96 m <sup>3</sup>	<b>1.25 yd<sup>3</sup></b>	1.0 m <sup>3</sup>	<b>1.31 yd<sup>3</sup></b>	1.15 m <sup>3</sup>	<b>1.5 yd<sup>3</sup></b>
Width	2262 mm	<b>89"</b>	2406 mm	<b>95"</b>	2406 mm	<b>95"</b>
Lift capacity at maximum height	3716 kg	<b>8193 lb</b>	3707 kg	<b>8173 lb</b>	3682 kg	<b>8117 lb</b>
Lift breakout force	51.1 kN	<b>11,484 lbf</b>	51.5 kN	<b>11,575 lbf</b>	50.8 kN	<b>11,415 lbf</b>
Tilt breakout force	46.3 kN	<b>10,411 lbf</b>	48.9 kN	<b>10,999 lbf</b>	46.1 kN	<b>10,371 lbf</b>
7) Maximum hinge pin height	3490 mm	<b>11'5"</b>	3490 mm	<b>11'5"</b>	3490 mm	<b>11'5"</b>
8) Dump angle at full height		<b>44°</b>		<b>44°</b>		<b>44°</b>
Dump height at maximum angle	2679 mm	<b>8'9"</b>	2710 mm	<b>8'11"</b>	2680 mm	<b>8'10"</b>
9) Dump reach at maximum angle	869 mm	<b>2'10"</b>	836 mm	<b>2'9"</b>	868 mm	<b>2'10"</b>
10) Maximum bucket rollback at ground level		<b>40°</b>		<b>40°</b>		<b>40°</b>
11) Digging depth	105 mm	<b>4"</b>	105 mm	<b>4"</b>	105 mm	<b>4"</b>
Maximum grading angle		<b>110°</b>		<b>111°</b>		<b>110°</b>
Width of dozer cutting edge		<b>N/A</b>		<b>N/A</b>		<b>N/A</b>
12) Grill to bucket cutting edge, carry position	1600 mm	<b>5'3"</b>	1568 mm	<b>5'2"</b>	1597 mm	<b>5'3"</b>
13) Maximum operating height	4407 mm	<b>14'6"</b>	4407 mm	<b>14'6"</b>	4477 mm	<b>14'8"</b>
Jaw opening maximum		<b>N/A</b>		<b>N/A</b>		<b>N/A</b>
Bucket jaw clamping force		<b>N/A</b>		<b>N/A</b>		<b>N/A</b>
Weight (does not include teeth or forks)	447 kg	<b>985 lb</b>	457 kg	<b>1008 lb</b>	481 kg	<b>1060 lb</b>

LOADER BUCKET DIMENSIONS AND PERFORMANCE	IT Loader with Quick Coupler			
	Multi Purpose 1.0 m <sup>3</sup> (1.31 yd <sup>3</sup> )		Multi Purpose 1.07 m <sup>3</sup> (1.4 yd <sup>3</sup> )	
Capacity (SAE) rated	1.0 m <sup>3</sup>	<b>1.31 yd<sup>3</sup></b>	1.07 m <sup>3</sup>	<b>1.4 yd<sup>3</sup></b>
Width	2279 mm	<b>90"</b>	2425 mm	<b>95"</b>
Lift capacity at maximum height	3448 kg	<b>7601 lb</b>	3419 kg	<b>7537 lb</b>
Lift breakout force	49.7 kN	<b>11,168 lbf</b>	49.4 kN	<b>11,108 lbf</b>
Tilt breakout force	50.4 kN	<b>11,325 lbf</b>	50.2 kN	<b>11,288 lbf</b>
7) Maximum hinge pin height	3490 mm	<b>11'5"</b>	3490 mm	<b>11'5"</b>
8) Dump angle at full height		<b>44°</b>		<b>44°</b>
Dump height at maximum angle	2745 mm	<b>9'0"</b>	2745 mm	<b>9'0"</b>
9) Dump reach at maximum angle	814 mm	<b>2'8"</b>	814 mm	<b>2'8"</b>
10) Maximum bucket rollback at ground level		<b>39°</b>		<b>39°</b>
11) Digging depth	95 mm	<b>4"</b>	95 mm	<b>4"</b>
Maximum grading angle		<b>112°</b>		<b>112°</b>
Width of dozer cutting edge	2262 mm	<b>7'5"</b>	2406 mm	<b>7'11"</b>
12) Grill to bucket cutting edge, carry position	1529 mm	<b>5'0"</b>	1529 mm	<b>5'0"</b>
13) Maximum operating height	4480 mm	<b>14'8"</b>	4480 mm	<b>14'8"</b>
Jaw opening maximum	790 mm	<b>2'7"</b>	790 mm	<b>2'7"</b>
Bucket jaw clamping force	55.7 kN	<b>12,521 lbf</b>	55.7 kN	<b>12,521 lbf</b>
Weight (does not include teeth or forks)	724 kg	<b>1596 lb</b>	753 kg	<b>1660 lb</b>

BACKHOE DIMENSIONS AND PERFORMANCE	Standard Stick		Extendible Stick Retracted		Extendible Stick Extended	
14) Digging depth, SAE (maximum)	4686 mm	<b>15'4"</b>	4795 mm	<b>15'9"</b>	5935 mm	<b>19'6"</b>
15) Digging depth, 610 mm (2'0") flat bottom	4660 mm	<b>15'3"</b>	4766 mm	<b>15'8"</b>	5906 mm	<b>19'5"</b>
Reach from rear axle centerline at ground line	7133 mm	<b>23'5"</b>	7227 mm	<b>23'9"</b>	8316 mm	<b>27'3"</b>
16) Reach from swing pivot at ground line	6043 mm	<b>19'10"</b>	6137 mm	<b>20'2"</b>	7226 mm	<b>23'8"</b>
Maximum operating height	6007 mm	<b>19'9"</b>	6075 mm	<b>19'11"</b>	6958 mm	<b>22'10"</b>
Loading height	3961 mm	<b>13'0"</b>	3921 mm	<b>12'10"</b>	4533 mm	<b>14'10"</b>
17) Loading reach	1855 mm	<b>6'1"</b>	2022 mm	<b>6'8"</b>	3003 mm	<b>9'10"</b>
Swing arc		<b>180°</b>		<b>180°</b>		<b>180°</b>
Bucket rotation		<b>205°</b>		<b>204°</b>		<b>204°</b>
18) Stabilizer spread, operating position (center of pad)	3310 mm	<b>10'10"</b>	3310 mm	<b>10'10"</b>	3310 mm	<b>10'10"</b>
19) Stabilizer spread, operating position (outside edge of pad)	3770 mm	<b>12'4"</b>	3770 mm	<b>12'4"</b>	3770 mm	<b>12'4"</b>
Stabilizer spread, transport position	2322 mm	<b>7'7"</b>	2322 mm	<b>7'7"</b>	2322 mm	<b>7'7"</b>
Bucket dig force	71.9 kN	<b>16,156 lbf</b>	70.9 kN	<b>15,932 lbf</b>	70.9 kN	<b>15,932 lbf</b>
Stick dig force	44.8 kN	<b>10,067 lbf</b>	43.8 kN	<b>9856 lbf</b>	32.4 kN	<b>7287 lbf</b>



DIMENSIONS WITH FORKS/ MATERIAL-HANDLING ARM	Cat 430F2 IT Operating Specifications with Forks					
Fork Tine Length	1070 mm (3'6")		1220 mm (4'0")		1370 mm (4'6")	
Operating load (SAE J1197)	2448 kg	<b>5397 lb</b>	2368 kg	<b>5220 lb</b>	2292 kg	<b>5054 lb</b>
SAE load center	535 mm	<b>1'9"</b>	610 mm	<b>2'0"</b>	685 mm	<b>2'3"</b>
Operating load (CEN 474-4)	2772 kg	<b>6111 lb</b>	2749 kg	<b>6062 lb</b>	2726 kg	<b>6009 lb</b>
CEN load center	500 mm	<b>1'8"</b>	500 mm	<b>1'8"</b>	500 mm	<b>1'8"</b>
Overall length (A) (forks on ground)	7822 mm	<b>25'8"</b>	7973 mm	<b>26'2"</b>	8121 mm	<b>26'8"</b>

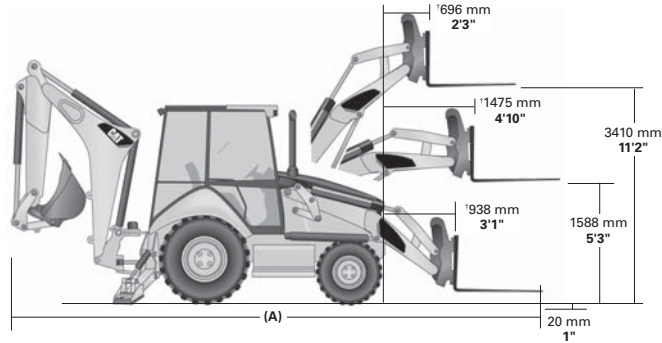

Operating load is hydraulic and tip limited.

*†Measured from nose of machine.*

DIMENSIONS WITH FORKS/ MATERIAL-HANDLING ARM	Cat 430F IT Operating Specifications with Material-Handling Arm					
Material-Handling Arm Position	Retracted		Mid-Position		Extended	
Operating load (SAE J1197 and CEN 474-4)	1058 kg	<b>2333 lb</b>	674 kg	<b>1487 lb</b>	495 kg	<b>1092 lb</b>
Overall length, maximum	9008 mm	<b>29'7"</b>	10 005 mm	<b>32'10"</b>	11 005 mm	<b>36'1"</b>

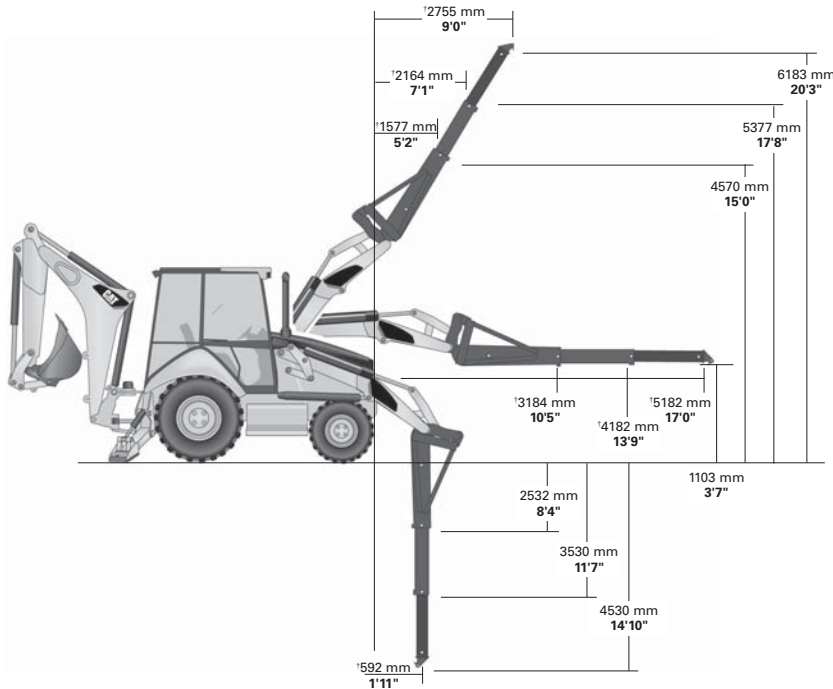

Operating load is hydraulic and tip limited.

Dimensions and performance specifications shown are for 4WD machines equipped with 12.5/80-18 I-3 front tires, 19.5L-24 R-4 ATU rear tires, ROPS canopy, standard stick with 610 mm (24 in) standard duty bucket, and 1.00 m<sup>3</sup> (1.31 yd<sup>3</sup>) loader bucket and standard equipment unless otherwise specified.

*†Measured from nose of machine.*

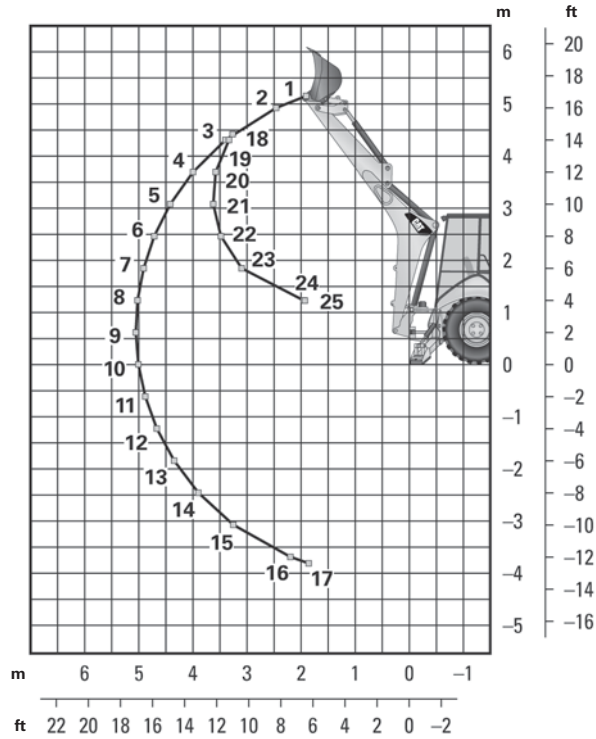

**Standard Stick**

Boom Lifting

1	1508 kg	<b>3318 lb</b>
2	1782 kg	<b>3921 lb</b>
3	1936 kg	<b>4258 lb</b>
4	1925 kg	<b>4236 lb</b>
5	1878 kg	<b>4131 lb</b>
6	1819 kg	<b>4001 lb</b>
7	1757 kg	<b>3866 lb</b>
8	1698 kg	<b>3735 lb</b>
9	1641 kg	<b>3610 lb</b>
10	1588 kg	<b>3493 lb</b>
11	1539 kg	<b>3387 lb</b>
12	1496 kg	<b>3291 lb</b>
13	1459 kg	<b>3211 lb</b>
14	1432 kg	<b>3151 lb</b>
15	1425 kg	<b>3136 lb</b>
16	1503 kg	<b>3307 lb</b>
17	1573 kg	<b>3461 lb</b>

Stick Lifting

18	2453 kg	<b>5397 lb</b>
19	2636 kg	<b>5800 lb</b>
20	2830 kg	<b>6226 lb</b>
21	2773 kg	<b>6100 lb</b>
22	2906 kg	<b>6394 lb</b>
23	3367 kg	<b>7408 lb</b>
24	6152 kg	<b>13,535 lb</b>
25	6240 kg	<b>13,728 lb</b>

Lift Capacities are over-end values. Machine equipped with AWD, OROPS, 1.0 m<sup>3</sup> (1.31 yd<sup>3</sup>) general purpose bucket, and 460 kg (1015 lb) counterweight.

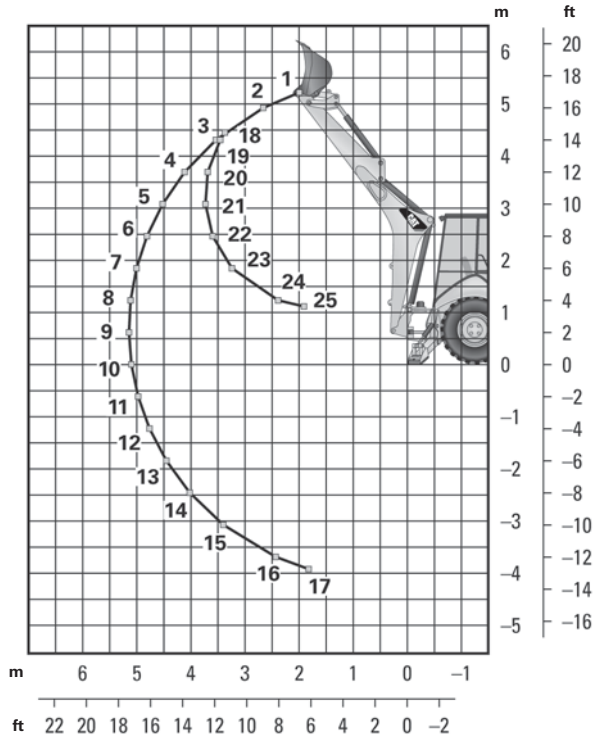

**Extendible Stick Retracted**

Boom Lifting

1	1250 kg	<b>2751 lb</b>
2	1541 kg	<b>3391 lb</b>
3	1663 kg	<b>3659 lb</b>
4	1654 kg	<b>3639 lb</b>
5	1610 kg	<b>3542 lb</b>
6	1555 kg	<b>3421 lb</b>
7	1497 kg	<b>3294 lb</b>
8	1441 kg	<b>3169 lb</b>
9	1386 kg	<b>3049 lb</b>
10	1335 kg	<b>2936 lb</b>
11	1287 kg	<b>2832 lb</b>
12	1244 kg	<b>2738 lb</b>
13	1207 kg	<b>2656 lb</b>
14	1178 kg	<b>2593 lb</b>
15	1166 kg	<b>2565 lb</b>
16	1211 kg	<b>2665 lb</b>
17	1316 kg	<b>2896 lb</b>

Stick Lifting

18	2158 kg	<b>4747 lb</b>
19	2367 kg	<b>5208 lb</b>
20	2538 kg	<b>5583 lb</b>
21	2486 kg	<b>5469 lb</b>
22	2599 kg	<b>5719 lb</b>
23	2979 kg	<b>6553 lb</b>
24	4516 kg	<b>9934 lb</b>
25	6083 kg	<b>13,382 lb</b>

Lift Capacities are over-end values. Machine equipped with AWD, OROPS, 1.0 m<sup>3</sup> (1.31 yd<sup>3</sup>) general purpose bucket, and 460 kg (1015 lb) counterweight.

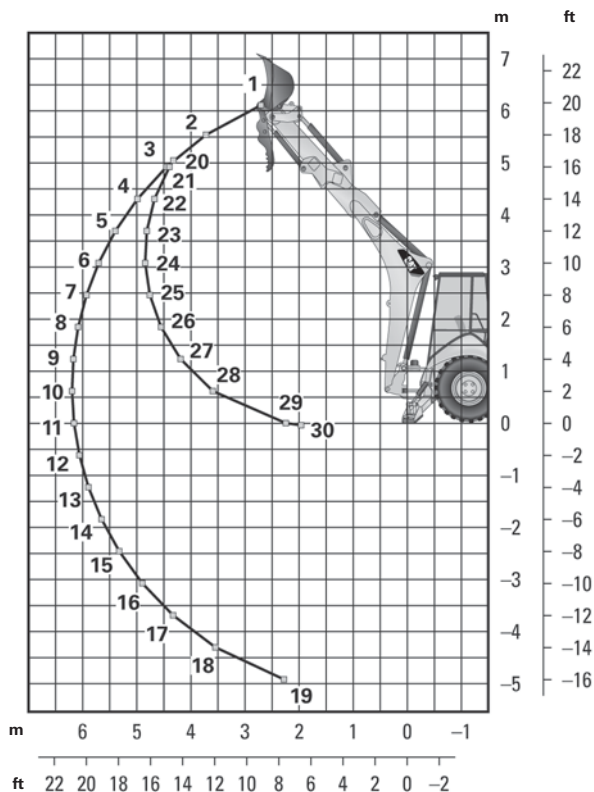

**Extendible Stick Extended**

Boom Lifting

1	679 kg	1493 lb
2	1017 kg	2237 lb
3	1124 kg	2474 lb
4	1158 kg	2547 lb
5	1161 kg	2553 lb
6	1149 kg	2527 lb
7	1129 kg	2484 lb
8	1106 kg	2433 lb
9	1081 kg	2378 lb
10	1056 kg	2323 lb
11	1032 kg	2270 lb
12	1009 kg	2220 lb
13	989 kg	2176 lb
14	972 kg	2138 lb
15	959 kg	2111 lb
16	954 kg	2100 lb
17	963 kg	2119 lb
18	1005 kg	2210 lb
19	1211 kg	2663 lb

Stick Lifting

20	1197 kg	2633 lb
21	1277 kg	2810 lb
22	1565 kg	3444 lb
23	1735 kg	3817 lb
24	1715 kg	3774 lb
25	1753 kg	3856 lb
26	1860 kg	4092 lb
27	2079 kg	4575 lb
28	2563 kg	5638 lb
29	4910 kg	10,802 lb
30	5883 kg	12,943 lb

Lift Capacities are over-end values. Machine equipped with AWD, OROPS, 1.0 m<sup>3</sup> (1.31 yd<sup>3</sup>) general purpose bucket, and 460 kg (1015 lb) counterweight.

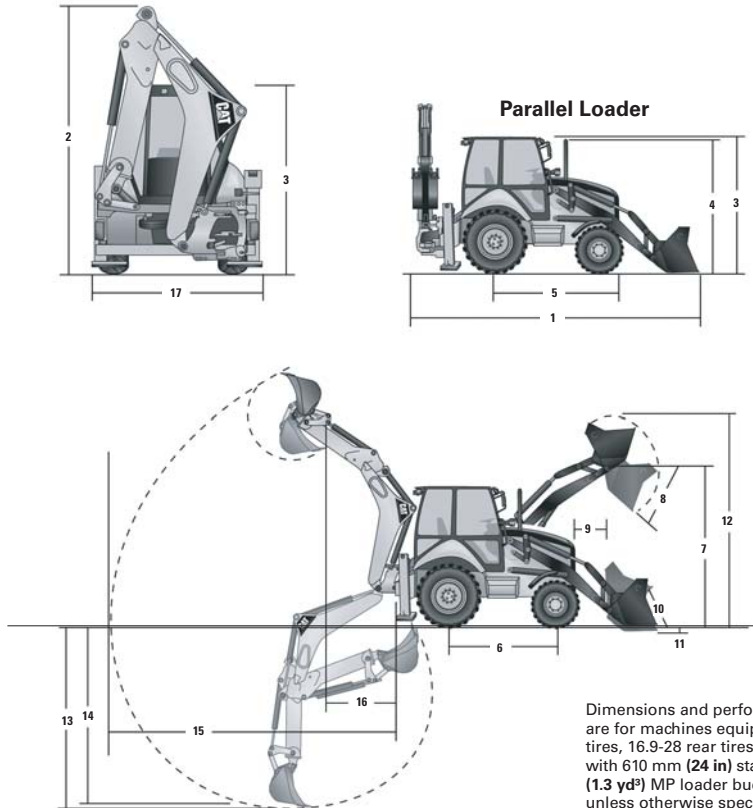

Dimensions and performance specifications shown are for machines equipped with 12.5/80-18 front tires, 16.9-28 rear tires, standard cab, standard stick with 610 mm (24 in) standard duty bucket, and 1.0 m<sup>3</sup> (1.3 yd<sup>3</sup>) MP loader bucket and standard equipment unless otherwise specified.

MACHINE DIMENSIONS	Standard Frame					
	General Purpose 1.0 m <sup>3</sup> (1.31 yd <sup>3</sup> )		Multi Purpose 1.03 m <sup>3</sup> (1.35 yd <sup>3</sup> )		Multi Purpose with Forks 1.03 m <sup>3</sup> (1.35 yd <sup>3</sup> )	
1) Overall length (loader on ground)	7398 mm	24'3"	7353 mm	24'1"	7353 mm	24'1"
Overall transport length	5750 mm	18'10"	5704 mm	18'9"	5704 mm	18'9"
2) Overall transport height S-Stick	3779 mm	12'5"	3779 mm	12'5"	3779 mm	12'5"
Overall transport height E-Stick	3771 mm	12'4"	3771 mm	12'4"	3771 mm	12'4"
Overall width (Standard)	2352 mm	7'9"	2352 mm	7'9"	2352 mm	7'9"
Overall width (Narrow)	2352 mm	7'9"	2352 mm	7'9"	2352 mm	7'9"
3) Height to top of cab/canopy	2897 mm	9'6"	2897 mm	9'6"	2897 mm	9'6"
4) Height to top of exhaust stack	2744 mm	9'0"	2744 mm	9'0"	2744 mm	9'0"
Height to loader hinge pin (transport)	361 mm	1'2"	318 mm	1'1"	318 mm	1'1"
Ground clearance (stabilizer feet)	333 mm	1'1"	333 mm	1'1"	333 mm	1'1"
Ground clearance (LH step)	323 mm	1'1"	323 mm	1'1"	323 mm	1'1"
Ground clearance (AWD guard)	318 mm	1'1"	318 mm	1'1"	318 mm	1'1"
Ground clearance (485 kg/1170 lb counterweight)	287 mm	11"	287 mm	11"	287 mm	11"
5) Rear axle centerline to front grill	2705 mm	8'10"	2705 mm	8'10"	2705 mm	8'10"
Front wheel tread gauge	1895 mm	6'3"	1895 mm	6'3"	1895 mm	6'3"
Rear wheel tread gauge	1714 mm	5'7"	1714 mm	5'7"	1714 mm	5'7"
6) Wheelbase (AWD)	2200 mm	7'3"	2200 mm	7'3"	2200 mm	7'3"

MACHINE DIMENSIONS	Narrow Frame		Quick Coupler			
	Multi Purpose 0.96 m <sup>3</sup> (1.25 yd <sup>3</sup> )		General Purpose 1.03 m <sup>3</sup> (1.35 yd <sup>3</sup> )		Multi Purpose 1.03 m <sup>3</sup> (1.35 yd <sup>3</sup> )	
1) Overall length (loader on ground)	7353 mm	24'1"	7507 mm	24'8"	7402 mm	24'3"
Overall transport length	5704 mm	18'10"	5859 mm	19'3"	5754 mm	18'11"
2) Overall transport height S-Stick	3779 mm	12'5"	3779 mm	12'5"	3779 mm	12'5"
Overall transport height E-Stick	3771 mm	12'4"	3771 mm	12'4"	3771 mm	12'4"
Overall width (Standard)	2352 mm	7'9"	2352 mm	7'9"	2352 mm	7'9"
Overall width (Narrow)	2352 mm	7'9"	2352 mm	7'9"	2352 mm	7'9"
3) Height to top of cab/canopy	2897 mm	9'6"	2897 mm	9'6"	2897 mm	9'6"
4) Height to top of exhaust stack	2744 mm	9'0"	2744 mm	9'0"	2744 mm	9'0"
Height to loader hinge pin (transport)	318 mm	1'1"	354 mm	1'2"	276 mm	1'1"
Ground clearance (stabilizer feet)	333 mm	1'1"	333 mm	1'1"	333 mm	1'1"
Ground clearance (LH step)	323 mm	1'1"	323 mm	1'1"	323 mm	1'1"
Ground clearance (AWD guard)	318 mm	1'1"	318 mm	1'1"	318 mm	1'1"
Ground clearance (485 kg/1170 lb counterweight)	287 mm	1'1"	287 mm	1'1"	287 mm	1'1"
5) Rear axle centerline to front grill	2705 mm	8'10"	2705 mm	8'10"	2705 mm	8'10"
Front wheel tread gauge	1895 mm	6'3"	1895 mm	6'3"	1895 mm	6'3"
Rear wheel tread gauge	1714 mm	5'7"	1714 mm	5'7"	1714 mm	5'7"
6) Wheelbase (AWD)	2200 mm	7'3"	2200 mm	7'3"	2200 mm	7'3"

LOADER BUCKET DIMENSIONS AND PERFORMANCE	Standard Frame					
	General Purpose 1.0 m <sup>3</sup> (1.31 yd <sup>3</sup> )		Multi Purpose 1.03 m <sup>3</sup> (1.35 yd <sup>3</sup> )		Multi Purpose with Forks 1.03 m <sup>3</sup> (1.35 yd <sup>3</sup> )	
Capacity (SAE) rated	1.0 m <sup>3</sup>	1.31 yd <sup>3</sup>	1.03 m <sup>3</sup>	1.35 yd <sup>3</sup>	1.03 m <sup>3</sup>	1.35 yd <sup>3</sup>
Width	2406 mm	95"	2406 mm	95"	2406 mm	95"
Lift capacity at maximum height	3817 kg	8415 lb	3580 kg	7893 lb	3402 kg	7500 lb
Lift breakout force	54.8 kN	12,324 lbf	53.3 kN	11,993 lbf	51.7 kN	11,623 lbf
Tilt breakout force	54.8 kN	12,330 lbf	60.3 kN	13,561 lbf	59.4 kN	13,354 lbf
7) Maximum hinge pin height	3497 mm	11'6"	3497 mm	11'6"	3497 mm	11'6"
8) Dump angle at full height		45°		45°		45°
Dump height at maximum angle	2796 mm	9'2"	2823 mm	9'3"	2823 mm	9'3"
9) Dump reach at maximum angle	805 mm	2'8"	731 mm	2'5"	731 mm	2'5"
10) Maximum bucket rollback at ground level		38°		39°		39°
11) Digging depth	61 mm	2"	94 mm	4"	94 mm	4"
Maximum grading angle		114°		116°		116°
Width of dozer cutting edge		N/A	2406 mm	7'11"	2406 mm	7'11"
Grill to bucket cutting edge, carry position	1467 mm	4'10"	1419 mm	4'8"	1419 mm	4'8"
12) Maximum operating height	4394 mm	14'5"	4427 mm	14'6"	4883 mm	16'0"
Jaw opening maximum		N/A	790 mm	2'7"	790 mm	2'7"
Bucket jaw clamping force		N/A	61 kN	13,699 lbf	61 kN	13,699 lbf
Weight (does not include teeth or forks)	428 kg	942 lb	611 kg	1347 lb	705 kg	1554 lb

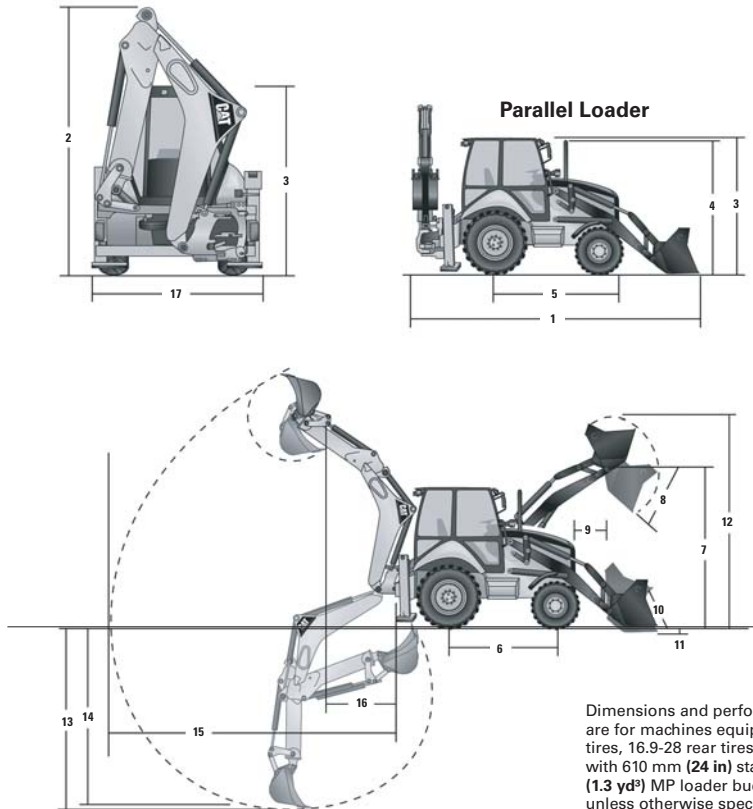

Dimensions and performance specifications shown are for machines equipped with 12.5/80-18 front tires, 16.9-28 rear tires, standard cab, standard stick with 610 mm (24 in) standard duty bucket, and 1.0 m<sup>3</sup> (1.3 yd<sup>3</sup>) MP loader bucket and standard equipment unless otherwise specified.

LOADER BUCKET DIMENSIONS AND PERFORMANCE	Narrow Frame		Quick Coupler			
	Multi Purpose 0.96 m <sup>3</sup> (1.25 yd <sup>3</sup> )		General Purpose 1.03 m <sup>3</sup> (1.35 yd <sup>3</sup> )		Multi Purpose 1.03 m <sup>3</sup> (1.35 yd <sup>3</sup> )	
Capacity (SAE) rated	0.96 m <sup>3</sup>	<b>1.25 yd<sup>3</sup></b>	1.03 m <sup>3</sup>	<b>1.35 yd<sup>3</sup></b>	1.03 m <sup>3</sup>	<b>1.35 yd<sup>3</sup></b>
Width	2262 mm	<b>89"</b>	2406 mm	<b>95"</b>	2406 mm	<b>95"</b>
Lift capacity at maximum height	3592 kg	<b>7989 lb</b>	3611 kg	<b>7961 lb</b>	3234 mm	<b>10'7"</b>
Lift breakout force	53.5 kN	<b>12,018 lbf</b>	51.8 kN	<b>11,650 lbf</b>	49.8 kN	<b>11,188 lbf</b>
Tilt breakout force	60.4 kN	<b>13,588 lbf</b>	48.8 kN	<b>10,963 lbf</b>	53.7 kN	<b>12,075 lbf</b>
7) Maximum hinge pin height	3497 mm	<b>11'6"</b>	3497 mm	<b>11'6"</b>	3497 mm	<b>11'6"</b>
8) Dump angle at full height		<b>45°</b>		<b>45°</b>		<b>45°</b>
Dump height at maximum angle	2823 mm	<b>9'3"</b>	2711 mm	<b>8'11"</b>	2789 mm	<b>9'2"</b>
9) Dump reach at maximum angle	731 mm	<b>2'5"</b>	837 mm	<b>2'9"</b>	783 mm	<b>2'7"</b>
10) Maximum bucket rollback at ground level		<b>39°</b>		<b>39°</b>		<b>39°</b>
11) Digging depth	94 mm	<b>4"</b>	100 mm	<b>4"</b>	81 mm	<b>3"</b>
Maximum grading angle		<b>116°</b>		<b>112°</b>		<b>114°</b>
Width of dozer cutting edge	2406 mm	<b>7'11"</b>		<b>N/A</b>	2406 mm	<b>7'11"</b>
Grill to bucket cutting edge, carry position	1419 mm	<b>4'8"</b>	1550 mm	<b>5'1"</b>	1435 mm	<b>4'9"</b>
12) Maximum operating height	4396 mm	<b>14'5"</b>	4396 mm	<b>14'5"</b>	4442 mm	<b>14'7"</b>
Jaw opening maximum		<b>N/A</b>	790 mm	<b>2'7"</b>	790 mm	<b>2'7"</b>
Bucket jaw clamping force		<b>N/A</b>	61 kN	<b>13,699 lbf</b>	61 kN	<b>13,699 lbf</b>
Weight (does not include teeth or forks)	842 kg	<b>1856 lb</b>	459 kg	<b>1012 lb</b>	697 kg	<b>1537 lb</b>

BACKHOE DIMENSIONS AND PERFORMANCE	Standard Stick		Extendible Stick Retracted 4264 mm (14'0")		Extendible Stick Extended 4264 mm (14'0")	
	13) Digging depth, manufacturers maximum	4775 mm	15'8"	4778 mm	15'8"	5696 mm
14) Digging depth, 610 mm (2'0") flat bottom	4235 mm	18'10"	4239 mm	13'11"	5235 mm	17'2"
15) Reach from swing pivot at ground line	5650 mm	18'6"	5655 mm	18'7"	6583 mm	21'7"
Loading height	4016 mm	13'2"	4025 mm	13'2"	4630 mm	15'2"
16) Loading reach	1669 mm	5'6"	1617 mm	5'4"	2475 mm	8'1"
Swing arc	180°		180°		180°	
Bucket rotation	205°		205°		205°	
17) Stabilizer width	2352 mm	7'9"	2352 mm	7'9"	2352 mm	7'9"
Bucket dig force	63.5 kN	14,264 lbf	63.4 kN	14,258 lbf	63.4 kN	14,258 lbf
Stick dig force	42.8 kN	9617 lbf	43.6 kN	9790 lbf	31.7 kN	7137 lbf
Total side shift travel (Standard frame)	1258 mm	4'2"	1258 mm	4'2"	1258 mm	4'2"
Total side shift travel (Narrow frame)	1096 mm	3'7"	1096 mm	3'7"	1096 mm	3'7"

BACKHOE DIMENSIONS AND PERFORMANCE	Extendible Stick Retracted 4872 mm (16'0")		Extendible Stick Extended 4872 mm (16'0")	
	13) Digging depth, manufacturers maximum	5196 mm	17'1"	6164 mm
14) Digging depth, 610 mm (2'0") flat bottom	4589 mm	15'1"	5611 mm	18'5"
15) Reach from swing pivot at ground line	6127 mm	20'1"	7078 mm	23'3"
Loading height	4579 mm	15'0"	5309 mm	17'5"
16) Loading reach	1535 mm	5'0"	2289 mm	7'6"
Swing arc	180°		180°	
Bucket rotation	205°		205°	
17) Stabilizer width	2352 mm	7'9"	2352 mm	7'9"
Bucket dig force	63.4 kN	14,260 lbf	63.4 kN	14,260 lbf
Stick dig force	47.3 kN	10,633 lbf	35.2 kN	7913 lbf
Total side shift travel (Standard frame)	1258 mm	4'2"	1258 mm	4'2"
Total side shift travel (Narrow frame)	1096 mm	3'7"	1096 mm	3'7"



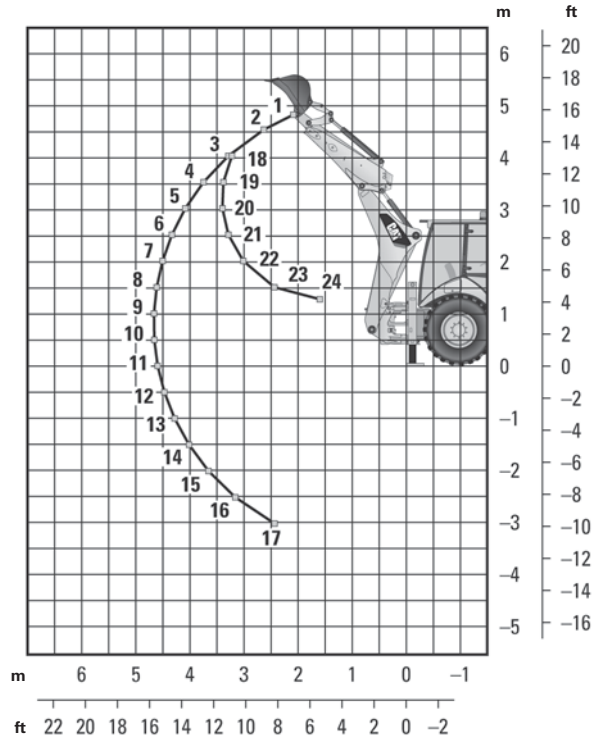

**Standard Stick**

Boom Lifting

1	1596 kg	<b>3511 lb</b>
2	1781 kg	<b>3918 lb</b>
3	1857 kg	<b>4086 lb</b>
4	1853 kg	<b>4077 lb</b>
5	1824 kg	<b>4012 lb</b>
6	1784 kg	<b>3926 lb</b>
7	1742 kg	<b>3832 lb</b>
8	1699 kg	<b>3738 lb</b>
9	1657 kg	<b>3646 lb</b>
10	1618 kg	<b>3559 lb</b>
11	1581 kg	<b>3479 lb</b>
12	1548 kg	<b>3405 lb</b>
13	1518 kg	<b>3340 lb</b>
14	1494 kg	<b>3287 lb</b>
15	1478 kg	<b>3251 lb</b>
16	1477 kg	<b>3249 lb</b>
17	1521 kg	<b>3346 lb</b>

Stick Lifting

18	2599 kg	<b>5717 lb</b>
19	2594 kg	<b>5706 lb</b>
20	2572 kg	<b>5659 lb</b>
21	2678 kg	<b>5892 lb</b>
22	2981 kg	<b>6558 lb</b>
23	3908 kg	<b>8598 lb</b>
24	5795 kg	<b>12,750 lb</b>

Lift Capacities are over-end values. Machine equipped with AWD, standard cab, 1.0 m<sup>3</sup> (1.31 yd<sup>3</sup>) multi-purpose bucket, and no counterweight. Extendible stick includes 115 kg (225 lb) counterweight.

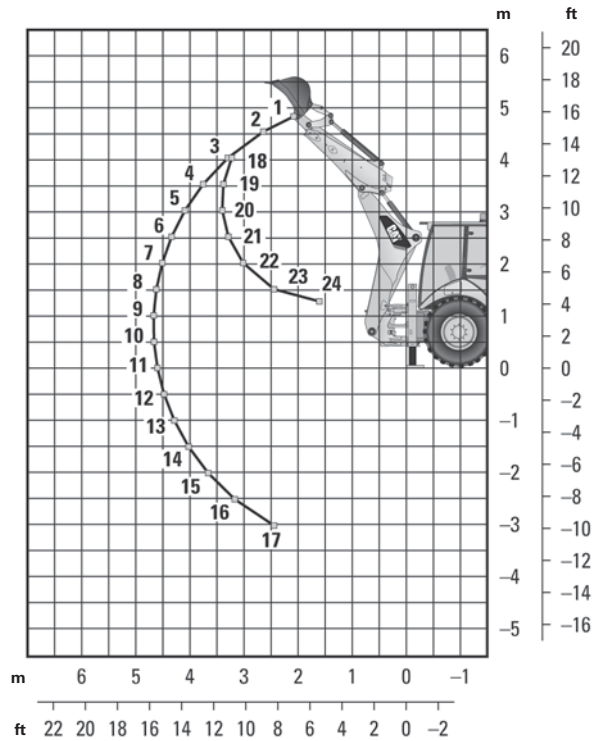

**Extendible Stick Retracted – 4264 mm (14'0")**

Boom Lifting

1	1514 kg	<b>3330 lb</b>
2	1676 kg	<b>3688 lb</b>
3	1732 kg	<b>3811 lb</b>
4	1717 kg	<b>3778 lb</b>
5	1681 kg	<b>3697 lb</b>
6	1636 kg	<b>3599 lb</b>
7	1589 kg	<b>3495 lb</b>
8	1542 kg	<b>3392 lb</b>
9	1496 kg	<b>3292 lb</b>
10	1453 kg	<b>3197 lb</b>
11	1413 kg	<b>3108 lb</b>
12	1375 kg	<b>3026 lb</b>
13	1342 kg	<b>2951 lb</b>
14	1312 kg	<b>2886 lb</b>
15	1289 kg	<b>2835 lb</b>
16	1277 kg	<b>2809 lb</b>
17	1298 kg	<b>2855 lb</b>

Stick Lifting

18	2546 kg	<b>5601 lb</b>
19	2467 kg	<b>5428 lb</b>
20	2443 kg	<b>5375 lb</b>
21	2544 kg	<b>5596 lb</b>
22	2836 kg	<b>6240 lb</b>
23	3735 kg	<b>8218 lb</b>
24	5740 kg	<b>12,629 lb</b>

Lift Capacities are over-end values. Machine equipped with AWD, standard cab, 1.0 m<sup>3</sup> (1.31 yd<sup>3</sup>) multi-purpose bucket, and no counterweight. Extendible stick includes 115 kg (225 lb) counterweight.

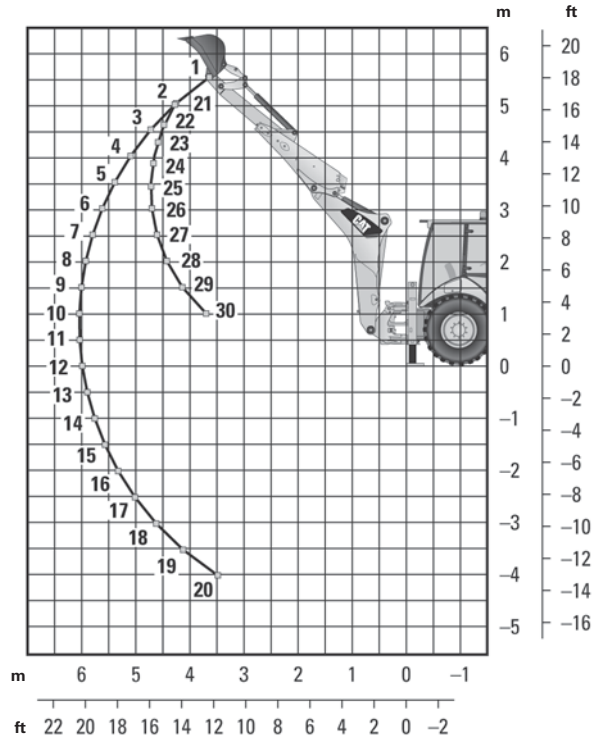

**Extendible Stick Extended – 4264 mm (14'0")**

Boom Lifting

1	904 kg	1989 lb
2	1092 kg	2403 lb
3	1193 kg	2624 lb
4	1236 kg	2719 lb
5	1252 kg	2754 lb
6	1253 kg	2757 lb
7	1247 kg	2743 lb
8	1235 kg	2718 lb
9	1221 kg	2687 lb
10	1206 kg	2654 lb
11	1191 kg	2620 lb
12	1176 kg	2588 lb
13	1163 kg	2558 lb
14	1151 kg	2533 lb
15	1143 kg	2514 lb
16	1139 kg	2505 lb
17	1142 kg	2511 lb
18	1157 kg	2546 lb
19	1200 kg	2641 lb
20	1340 kg	2948 lb

Stick Lifting

21	1371 kg	3016 lb
22	1634 kg	3595 lb
23	1760 kg	3872 lb
24	1751 kg	3852 lb
25	1785 kg	3926 lb
26	1870 kg	4114 lb
27	2033 kg	4473 lb
28	2352 kg	5175 lb
29	3199 kg	7037 lb
30	6409 kg	14,100 lb

Lift Capacities are over-end values. Machine equipped with AWD, standard cab, 1.0 m<sup>3</sup> (1.31 yd<sup>3</sup>) multi-purpose bucket, and no counterweight. Extendible stick includes 115 kg (225 lb) counterweight.

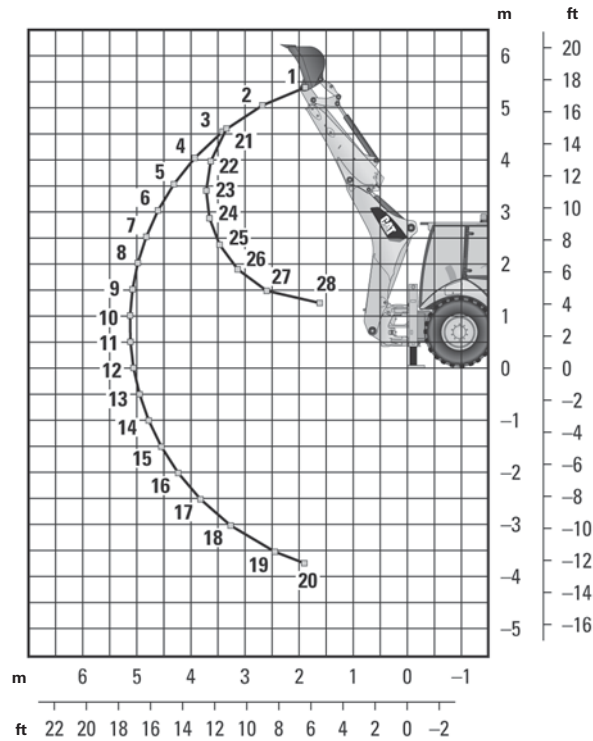

**Extendible Stick Retracted – 4872 mm (16'0")**

Boom Lifting

1	1660 kg	<b>3651 lb</b>
2	1997 kg	<b>4394 lb</b>
3	2079 kg	<b>4574 lb</b>
4	2068 kg	<b>4549 lb</b>
5	1996 kg	<b>4391 lb</b>
6	1833 kg	<b>4033 lb</b>
7	1721 kg	<b>3787 lb</b>
8	1644 kg	<b>3617 lb</b>
9	1593 kg	<b>3505 lb</b>
10	1565 kg	<b>3442 lb</b>
11	1556 kg	<b>3423 lb</b>
12	1567 kg	<b>3448 lb</b>
13	1601 kg	<b>3521 lb</b>
14	1602 kg	<b>3523 lb</b>
15	1568 kg	<b>3450 lb</b>
16	1540 kg	<b>3387 lb</b>
17	1519 kg	<b>3342 lb</b>
18	1514 kg	<b>3330 lb</b>
19	1556 kg	<b>3424 lb</b>
20	1638 kg	<b>3604 lb</b>

Stick Lifting

21	2712 kg	<b>5967 lb</b>
22	2488 kg	<b>5473 lb</b>
23	2427 kg	<b>5340 lb</b>
24	2461 kg	<b>5414 lb</b>
25	2591 kg	<b>5700 lb</b>
26	2864 kg	<b>6300 lb</b>
27	3442 kg	<b>7572 lb</b>
28	5357 kg	<b>11,785 lb</b>

Lift Capacities are over-end values. Machine equipped with AWD, standard cab, 1.0 m<sup>3</sup> (1.31 yd<sup>3</sup>) multi-purpose bucket, and no counterweight. Extendible stick includes 115 kg (225 lb) counterweight.

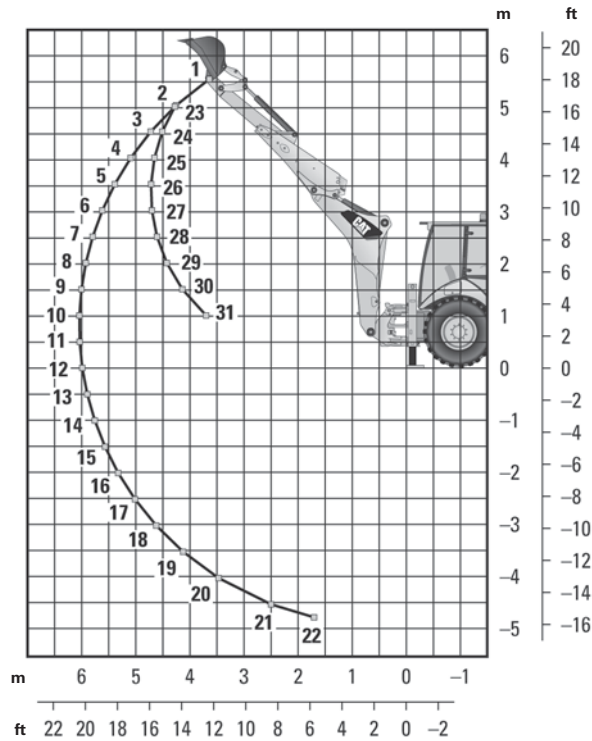

**Extendible Stick Extended – 4872 mm (16'0")**

Boom Lifting

1	1385 kg	<b>3046 lb</b>
2	1491 kg	<b>3280 lb</b>
3	1533 kg	<b>3373 lb</b>
4	1546 kg	<b>3401 lb</b>
5	1543 kg	<b>3394 lb</b>
6	1477 kg	<b>3250 lb</b>
7	1412 kg	<b>3105 lb</b>
8	1364 kg	<b>3000 lb</b>
9	1331 kg	<b>2927 lb</b>
10	1311 kg	<b>2883 lb</b>
11	1303 kg	<b>2866 lb</b>
12	1307 kg	<b>2875 lb</b>
13	1324 kg	<b>2912 lb</b>
14	1355 kg	<b>2981 lb</b>
15	1365 kg	<b>3002 lb</b>
16	1354 kg	<b>2980 lb</b>
17	1350 kg	<b>2969 lb</b>
18	1353 kg	<b>2977 lb</b>
19	1371 kg	<b>3016 lb</b>
20	1422 kg	<b>3127 lb</b>
21	1592 kg	<b>3503 lb</b>
22	1949 kg	<b>4288 lb</b>

Stick Lifting

23	1664 kg	<b>3661 lb</b>
24	1921 kg	<b>4225 lb</b>
25	1918 kg	<b>4220 lb</b>
26	1889 kg	<b>4157 lb</b>
27	1894 kg	<b>4167 lb</b>
28	1933 kg	<b>4253 lb</b>
29	2015 kg	<b>4433 lb</b>
30	2160 kg	<b>4752 lb</b>
31	2424 kg	<b>5333 lb</b>

Lift Capacities are over-end values. Machine equipped with AWD, standard cab, 1.0 m<sup>3</sup> (1.31 yd<sup>3</sup>) multi-purpose bucket, and no counterweight. Extendible stick includes 115 kg (225 lb) counterweight.

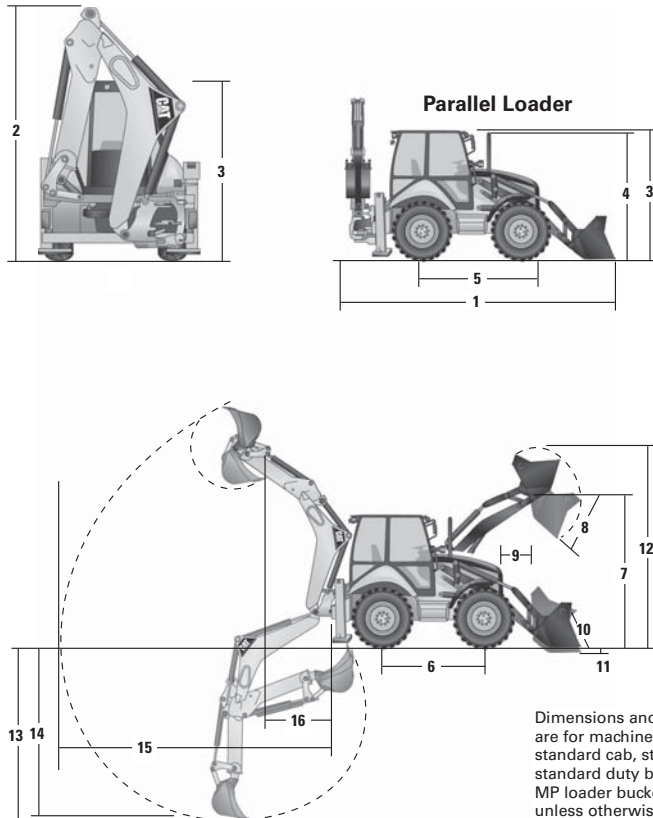

Dimensions and performance specifications shown are for machines equipped with 440/80R24 tires, standard cab, standard stick with 610 mm (24 in) standard duty bucket, and 1.15 m<sup>3</sup> (1.5 yd<sup>3</sup>) MP loader bucket and standard equipment unless otherwise specified.

MACHINE DIMENSIONS	General Purpose 1.15 m <sup>3</sup> (1.5 yd <sup>3</sup> )		Multi Purpose 1.15 m <sup>3</sup> (1.5 yd <sup>3</sup> )		Multi Purpose with Forks 1.15 m <sup>3</sup> (1.5 yd <sup>3</sup> )	
	mm	ft"	mm	ft"	mm	ft"
1) Overall length (loader on ground)	7574 mm	24'10"	7553 mm	24'9"	7533 mm	24'9"
Overall transport length	5921 mm	19'5"	5900 mm	19'4"	5900 mm	19'4"
2) Overall transport height S-Stick	3780 mm	12'5"	3780 mm	12'5"	3780 mm	12'5"
Overall transport height E-Stick	3769 mm	12'4"	3769 mm	12'4"	3769 mm	12'4"
Overall width	2322 mm	7'7"	2322 mm	7'7"	2322 mm	7'7"
3) Height to top of cab/canopy	2889 mm	9'6"	2889 mm	9'6"	2889 mm	9'6"
4) Height to top of exhaust stack	2754 mm	9'0"	2754 mm	9'0"	2754 mm	9'0"
Height to loader hinge pin (transport)	365 mm	1'2"	362 mm	1'2"	369 mm	1'3"
Ground clearance (stabilizer feet)	395 mm	1'4"	395 mm	1'4"	395 mm	1'4"
Ground clearance (LH step)	300 mm	1'0"	300 mm	1'0"	300 mm	1'0"
Ground clearance (AWD guard)	353 mm	1'2"	353 mm	1'2"	353 mm	1'2"
5) Rear axle centerline to front grill	2795 mm	9'2"	2795 mm	9'2"	2795 mm	9'2"
Front wheel tread gauge	1826 mm	6'0"	1826 mm	6'0"	1826 mm	6'0"
Rear wheel tread gauge	1707 mm	5'7"	1707 mm	5'7"	1707 mm	5'7"
6) Wheelbase (AWD)	2235 mm	7'4"	2235 mm	7'4"	2235 mm	7'4"

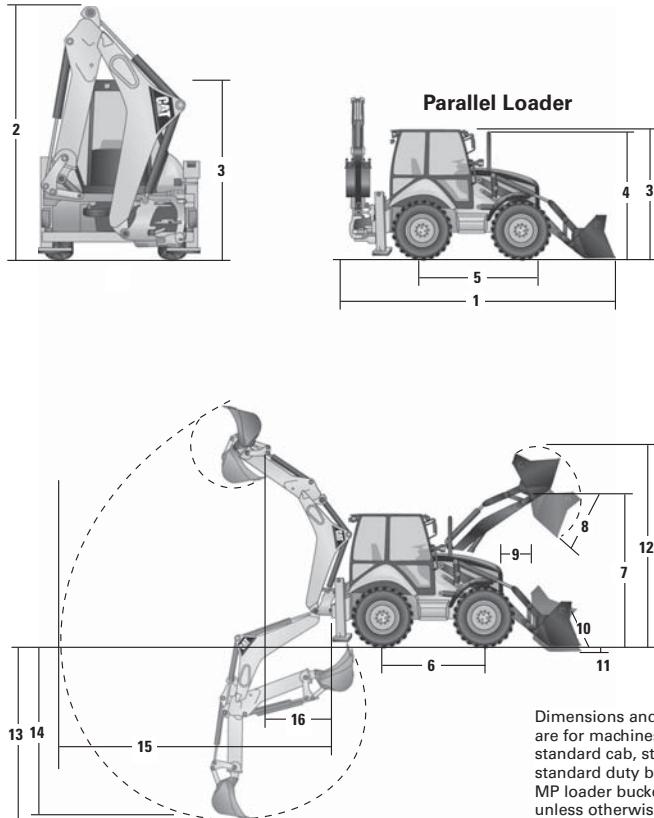

Dimensions and performance specifications shown are for machines equipped with 440/80R24 tires, standard cab, standard stick with 610 mm (24 in) standard duty bucket, and 1.15 m<sup>3</sup> (1.5 yd<sup>3</sup>) MP loader bucket and standard equipment unless otherwise specified.

LOADER BUCKET DIMENSIONS AND PERFORMANCE	General Purpose 1.15 m <sup>3</sup> (1.5 yd <sup>3</sup> )		Multi Purpose 1.15 m <sup>3</sup> (1.5 yd <sup>3</sup> )		Multi Purpose with Forks 1.15 m <sup>3</sup> (1.5 yd <sup>3</sup> )	
	Capacity (SAE) rated	1.15 m <sup>3</sup>	1.5 yd <sup>3</sup>	1.15 m <sup>3</sup>	1.5 yd <sup>3</sup>	1.15 m <sup>3</sup>
Width	2434 mm	96"	2434 mm	96"	2434 mm	96"
Lift capacity at maximum height	4661 kg	10,276 lb	4329 kg	9544 lb	4150 kg	9150 lb
Lift breakout force	61.3 kN	13,770 lbf	58.5 kN	13,156 lbf	56.6 kN	12,715 lbf
Tilt breakout force	63.4 kN	14,252 lbf	63.6 kN	14,306 lbf	62.3 kN	14,008 lbf
7) Maximum hinge pin height	3518 mm	11'7"	3518 mm	11'7"	3518 mm	11'7"
8) Dump angle at full height		45°		45°		45°
Dump height at maximum angle	2745 mm	9'0"	2760 mm	9'1"	2760 mm	9'1"
9) Dump reach at maximum angle	923 mm	3'0"	908 mm	3'0"	908 mm	3'0"
10) Maximum bucket rollback at ground level		44°		44°		44°
11) Digging depth	154 mm	6"	154 mm	6"	154 mm	6"
Maximum grading angle		109°		110°		110°
Width of dozer cutting edge		N/A	2434 mm	8'0"	2434 mm	8'0"
Grill to bucket cutting edge, carry position	1494 mm	4'11"	1479 mm	4'10"	1482 mm	4'10"
12) Maximum operating height	4386 mm	14'5"	4463 mm	14'8"	4341 mm	14'3"
Jaw opening maximum		N/A	790 mm	2'7"	790 mm	2'7"
Bucket jaw clamping force		N/A	62.2 kN	13,988 lbf	62.2 kN	13,988 lbf
Weight (does not include teeth or forks)	438 kg	966 lb	752 kg	1658 lb	927 kg	2044 lb

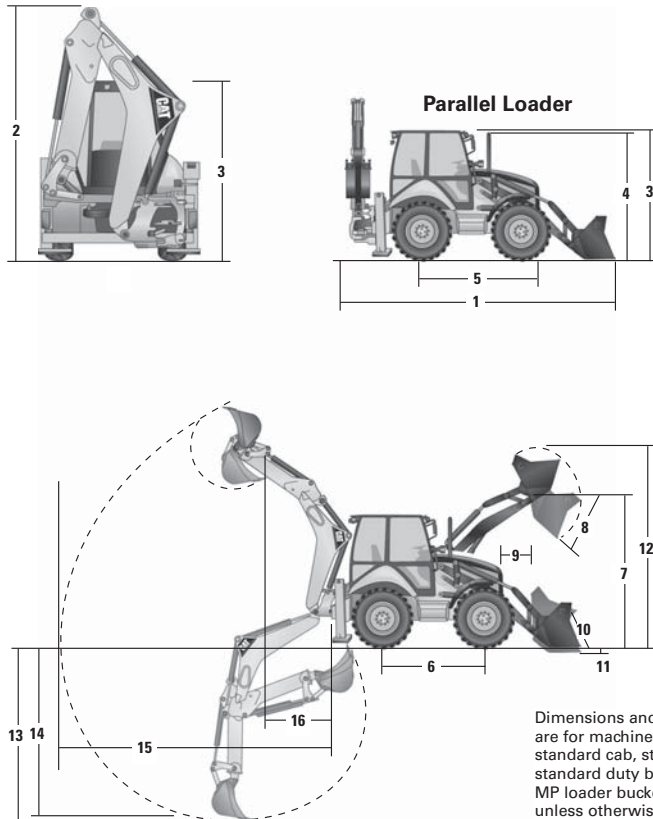

Dimensions and performance specifications shown are for machines equipped with 440/80R24 tires, standard cab, standard stick with 610 mm (24 in) standard duty bucket, and 1.15 m<sup>3</sup> (1.5 yd<sup>3</sup>) MP loader bucket and standard equipment unless otherwise specified.

BACKHOE DIMENSIONS AND PERFORMANCE	Standard Stick		Extendible Stick Retracted 4264 mm (14'0")		Extendible Stick Extended 4264 mm (14'0")	
	13) Digging depth, manufacturers maximum	4827 mm	15'10"	4832 mm	15'10"	5748 mm
14) Digging depth, 610 mm (2'0") flat bottom	4306 mm	14'2"	4309 mm	14'2"	5296 mm	17'5"
15) Reach from swing pivot at ground line	5655 mm	18'7"	5660 mm	18'7"	6586 mm	21'7"
Loading height	3909 mm	12'10"	3920 mm	12'10"	4487 mm	14'9"
16) Loading reach	1808 mm	5'11"	1758 mm	5'9"	2642 mm	8'8"
Swing arc	180°		180°		180°	
Bucket rotation	205°		205°		205°	
Bucket dig force	63.4 kN	14,260 lbf	63.4 kN	14,254 lbf	63.4 kN	14,254 lbf
Stick dig force	36.1 kN	8115 lbf	36.8 kN	8265 lbf	26.9 kN	6041 lbf
Total side shift travel	1258 mm	4'2"	1258 mm	4'2"	1258 mm	4'2"



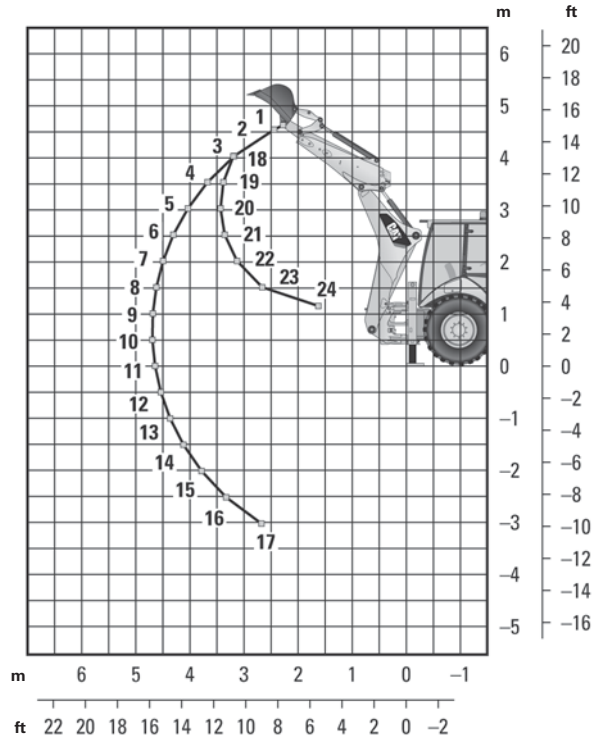

**Standard Stick**

Boom Lifting

1	1155 kg	<b>2541 lb</b>
2	1281 kg	<b>2818 lb</b>
3	1410 kg	<b>3103 lb</b>
4	1439 kg	<b>3167 lb</b>
5	1435 kg	<b>3157 lb</b>
6	1416 kg	<b>3115 lb</b>
7	1391 kg	<b>3060 lb</b>
8	1363 kg	<b>2999 lb</b>
9	1335 kg	<b>2937 lb</b>
10	1308 kg	<b>2878 lb</b>
11	1282 kg	<b>2821 lb</b>
12	1260 kg	<b>2771 lb</b>
13	1240 kg	<b>2728 lb</b>
14	1226 kg	<b>2697 lb</b>
15	1220 kg	<b>2683 lb</b>
16	1229 kg	<b>2705 lb</b>
17	1286 kg	<b>2830 lb</b>

Stick Lifting

18	2111 kg	<b>4644 lb</b>
19	1985 kg	<b>4367 lb</b>
20	1961 kg	<b>4315 lb</b>
21	2035 kg	<b>4477 lb</b>
22	2255 kg	<b>4961 lb</b>
23	2906 kg	<b>6394 lb</b>
24	5317 kg	<b>11,696 lb</b>

Lift Capacities are over-end values. Machine equipped with AWD, standard cab, 1.15 m<sup>3</sup> (1.5 yd<sup>3</sup>) multi-purpose bucket, 440/80R24 tires and 0 kg (0 lb) counterweight.

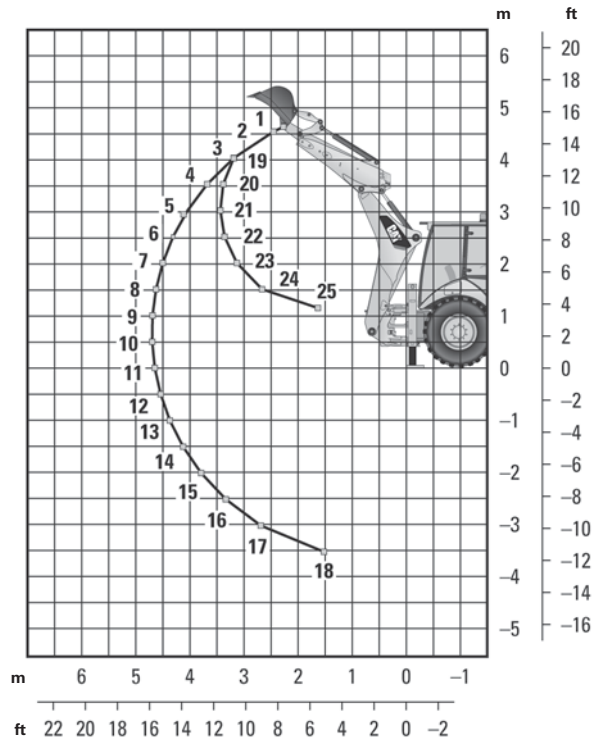

**Extendible Stick Retracted – 4264 mm (14'0")**

Boom Lifting

1	1062 kg	2337 lb
2	1179 kg	2593 lb
3	1286 kg	2830 lb
4	1304 kg	2870 lb
5	1293 kg	2844 lb
6	1268 kg	2790 lb
7	1238 kg	2725 lb
8	1207 kg	2655 lb
9	1175 kg	2585 lb
10	1144 kg	2517 lb
11	1115 kg	2453 lb
12	1088 kg	2394 lb
13	1064 kg	2342 lb
14	1045 kg	2299 lb
15	1032 kg	2270 lb
16	1031 kg	2269 lb
17	1067 kg	2347 lb
18	1401 kg	3083 lb

Stick Lifting

19	1991 kg	4380 lb
20	1859 kg	4089 lb
21	1833 kg	4032 lb
22	1902 kg	4183 lb
23	2112 kg	4646 lb
24	2739 kg	6025 lb
25	5041 kg	11,090 lb

Lift Capacities are over-end values. Machine equipped with AWD, standard cab, 1.15 m<sup>3</sup> (1.5 yd<sup>3</sup>) multi-purpose bucket, 440/80R24 tires and 0 kg (0 lb) counterweight.

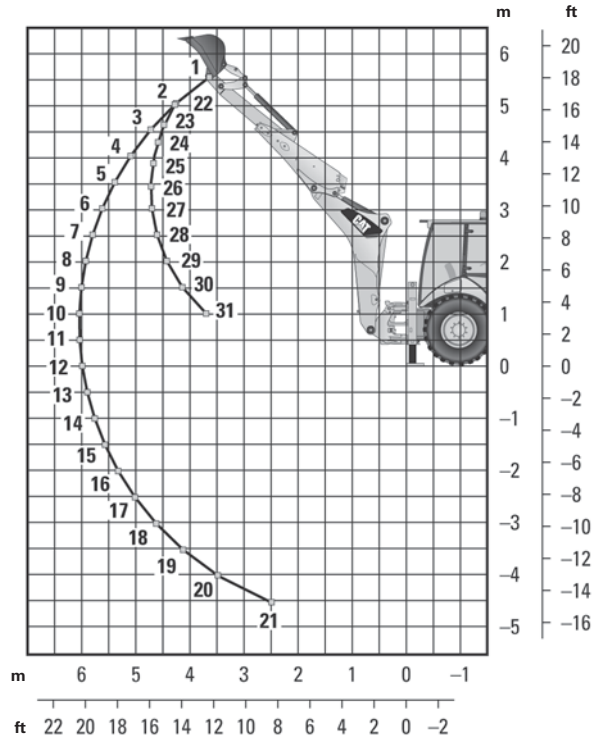

**Extendible Stick Extended – 4264 mm (14'0")**

Boom Lifting

1	629 kg	1383 lb
2	740 kg	1628 lb
3	855 kg	1881 lb
4	910 kg	2003 lb
5	937 kg	2062 lb
6	949 kg	2088 lb
7	951 kg	2093 lb
8	948 kg	2086 lb
9	942 kg	2072 lb
10	933 kg	2053 lb
11	924 kg	2034 lb
12	915 kg	2014 lb
13	907 kg	1996 lb
14	901 kg	1981 lb
15	896 kg	1972 lb
16	896 kg	1971 lb
17	902 kg	1985 lb
18	920 kg	2023 lb
19	962 kg	2117 lb
20	1088 kg	2395 lb
21	2846 kg	6260 lb

Stick Lifting

22	1109 kg	2440 lb
23	1315 kg	2893 lb
24	1308 kg	2877 lb
25	1298 kg	2855 lb
26	1321 kg	2906 lb
27	1383 kg	3043 lb
28	1503 kg	3307 lb
29	1737 kg	3821 lb
30	2333 kg	5132 lb
31	6090 kg	13,397 lb

Lift Capacities are over-end values. Machine equipped with AWD, standard cab, 1.15 m<sup>3</sup> (1.5 yd<sup>3</sup>) multi-purpose bucket, 440/80R24 tires and 0 kg (0 lb) counterweight.

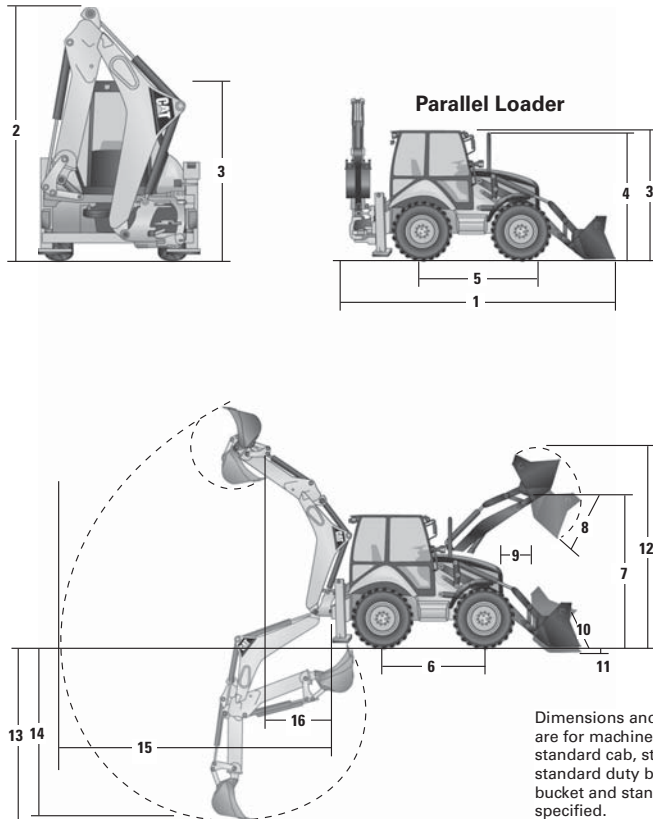

Dimensions and performance specifications shown are for machines equipped with 440/80R28 tires, standard cab, standard stick with 610 mm (24 in) standard duty bucket, and 1.3 m<sup>3</sup> (1.7 yd<sup>3</sup>) MP loader bucket and standard equipment unless otherwise specified.

MACHINE DIMENSIONS	Parallel Loader					
	General Purpose 1.3 m <sup>3</sup> (1.7 yd <sup>3</sup> )		Multi Purpose 1.3 m <sup>3</sup> (1.7 yd <sup>3</sup> )		Multi Purpose with Forks 1.3 m <sup>3</sup> (1.7 yd <sup>3</sup> )	
1) Overall length (loader on ground)	7548 mm	24'9"	7577 mm	24'10"	7577 mm	24'10"
Overall transport length	5892 mm	19'4"	5921 mm	19'5"	5921 mm	19'5"
2) Overall transport height S-Stick	3829 mm	12'7"	3829 mm	12'7"	3829 mm	12'7"
Overall transport height E-Stick	3818 mm	12'6"	3818 mm	12'6"	3818 mm	12'6"
Overall transport height E-Stick 4872 mm (16'0")	4008 mm	13'2"	4008 mm	13'2"	4008 mm	13'2"
Overall width	2322 mm	7'7"	2322 mm	7'7"	2322 mm	7'7"
3) Height to top of cab/canopy	2897 mm	9'6"	2897 mm	9'6"	2897 mm	9'6"
4) Height to top of exhaust stack	2754 mm	9'0"	2754 mm	9'0"	2754 mm	9'0"
Height to loader hinge pin (transport)	400 mm	1'4"	386 mm	1'3"	379 mm	1'3"
Ground clearance (stabilizer feet)	444 mm	1'4"	444 mm	1'5"	444 mm	1'5"
Ground clearance (LH step)	349 mm	1'2"	349 mm	1'2"	349 mm	1'2"
Ground clearance (AWD guard)	402 mm	1'4"	402 mm	1'4"	402 mm	1'4"
5) Rear axle centerline to front grill	2795 mm	9'2"	2795 mm	9'2"	2795 mm	9'2"
Front wheel tread gauge	1826 mm	6'0"	1826 mm	6'0"	1826 mm	6'0"
Rear wheel tread gauge	1707 mm	5'7"	1707 mm	5'7"	1707 mm	5'7"
6) Wheelbase (AWD)	2235 mm	7'4"	2235 mm	7'4"	2235 mm	7'4"

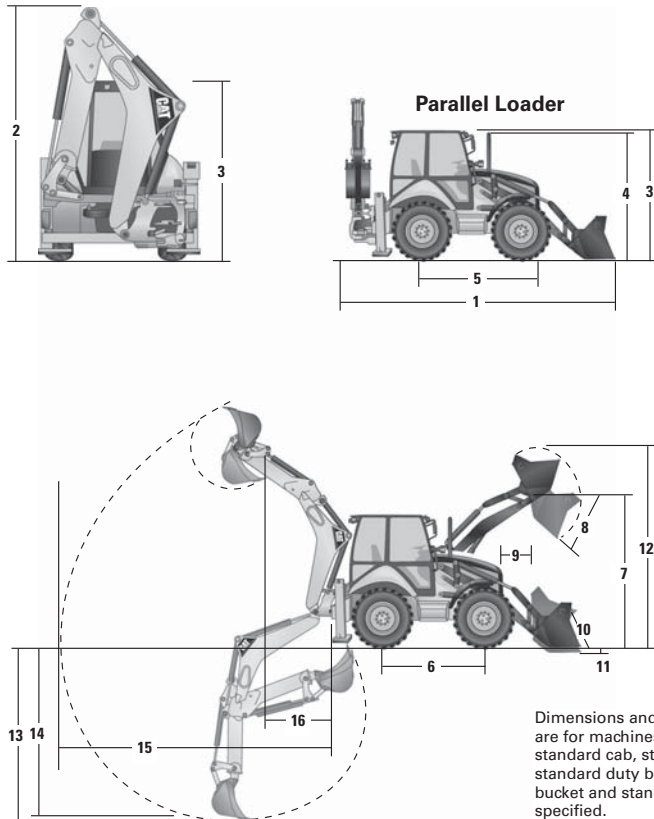

Dimensions and performance specifications shown are for machines equipped with 440/80R28 tires, standard cab, standard stick with 610 mm (24 in) standard duty bucket, and 1.3 m<sup>3</sup> (1.7 yd<sup>3</sup>) MP loader bucket and standard equipment unless otherwise specified.

MACHINE DIMENSIONS	Parallel Loader with Quick Coupler			
	General Purpose 1.3 m <sup>3</sup> (1.7 yd <sup>3</sup> )		Multi Purpose 1.3 m <sup>3</sup> (1.7 yd <sup>3</sup> )	
1) Overall length (loader on ground)	7621 mm	25'0"	7665 mm	25'2"
Overall transport length	5965 mm	19'7"	6010 mm	19'9"
2) Overall transport height S-Stick	3829 mm	12'7"	3829 mm	12'7"
Overall transport height E-Stick	3818 mm	12'6"	3818 mm	12'6"
Overall transport height E-Stick 4872 mm (16'0")	4008 mm	13'2"	4008 mm	13'2"
Overall width	2322 mm	7'7"	2322 mm	7'7"
3) Height to top of cab/canopy	2897 mm	9'6"	2897 mm	9'6"
4) Height to top of exhaust stack	2754 mm	9'0"	2754 mm	9'0"
Height to loader hinge pin (transport)	347 mm	1'2"	327 mm	1'1"
Ground clearance (stabilizer feet)	444 mm	1'5"	444 mm	1'5"
Ground clearance (LH step)	349 mm	1'2"	349 mm	1'2"
Ground clearance (AWD guard)	402 mm	1'4"	402 mm	1'4"
5) Rear axle centerline to front grill	2795 mm	9'2"	2795 mm	9'2"
Front wheel tread gauge	1826 mm	6'0"	1826 mm	6'0"
Rear wheel tread gauge	1707 mm	5'7"	1707 mm	5'7"
6) Wheelbase (2WD/AWD)	2235 mm	7'4"	2235 mm	7'4"

LOADER BUCKET DIMENSIONS AND PERFORMANCE	Parallel Loader					
	General Purpose 1.3 m <sup>3</sup> (1.7 yd <sup>3</sup> )		Multi Purpose 1.3 m <sup>3</sup> (1.7 yd <sup>3</sup> )		Multi Purpose with Forks 1.3 m <sup>3</sup> (1.7 yd <sup>3</sup> )	
Capacity (SAE) rated	1.3 m <sup>3</sup>	1.7 yd <sup>3</sup>	1.3 m <sup>3</sup>	1.7 yd <sup>3</sup>	1.3 m <sup>3</sup>	1.7 yd <sup>3</sup>
Width	2434 mm	96"	2434 mm	96"	2434 mm	96"
Lift capacity at maximum height	4638 kg	10,225 lb	4283 kg	9442 lb	4055 kg	8940 lb
Lift breakout force	61 249 N	13,769 lbf	57 718 N	12,975 lbf	55 582 N	12,495 lbf
Tilt breakout force	62 900 N	14,140 lbf	58 983 N	13,259 lbf	58 075 N	13,055 lbf
7) Maximum hinge pin height	3567 mm	11'8"	3567 mm	11'8"	3567 mm	11'8"
8) Dump angle at full height		45°		45°		45°
Dump height at maximum angle	2794 mm	9'2"	2773 mm	9'1"	2773 mm	9'1"
9) Dump reach at maximum angle	923 mm	3'0"	944 mm	3'1"	944 mm	3'1"
10) Maximum bucket rollback at ground level		43°		43°		43°
11) Digging depth	105 mm	4"	105 mm	4"	105 mm	4"
Maximum grading angle		111°		110°		110°
Width of dozer cutting edge		N/A		N/A		N/A
Grill to bucket cutting edge, carry position	1489 mm	4'11"	1503 mm	4'11"	1500 mm	4'11"
12) Maximum operating height	4570 mm	15'0"	4402 mm	14'5"	4402 mm	14'5"
Jaw opening maximum		N/A		N/A		N/A
Bucket jaw clamping force		N/A		N/A		N/A
Weight (does not include teeth or forks)	460 kg	1014 lb	798 kg	1759 lb	811 kg	1788 lb

LOADER BUCKET DIMENSIONS AND PERFORMANCE	Parallel Loader with Quick Coupler			
	General Purpose 1.3 m <sup>3</sup> (1.7 yd <sup>3</sup> )		Multi Purpose 1.3 m <sup>3</sup> (1.7 yd <sup>3</sup> )	
Capacity (SAE) rated	1.3 m <sup>3</sup>	1.7 yd <sup>3</sup>	1.3 m <sup>3</sup>	1.7 yd <sup>3</sup>
Width	2434 mm	96"	2434 mm	96"
Lift capacity at maximum height	4452 kg	9815 lb	4093 kg	9023 lb
Lift breakout force	58 946 N	13,251 lbf	55 213 N	12,412 lbf
Tilt breakout force	56 746 N	12,756 lbf	51 802 N	11,645 lbf
7) Maximum hinge pin height	3567 mm	11'8"	3567 mm	11'8"
8) Dump angle at full height		45°		45°
Dump height at maximum angle	2741 mm	9'0"	2710 mm	8'11"
9) Dump reach at maximum angle	972 mm	3'2"	1008 mm	3'4"
10) Maximum bucket rollback at ground level		43°		43°
11) Digging depth	108 mm	4"	104 mm	4"
Maximum grading angle		109°		110°
Width of dozer cutting edge		N/A		N/A
Grill to bucket cutting edge, carry position	1519 mm	5'0"	1541 mm	5'1"
12) Maximum operating height	4616 mm	15'2"	4637 mm	15'3"
Jaw opening maximum		N/A		N/A
Bucket jaw clamping force		N/A		N/A
Weight (does not include teeth or forks)	637 kg	1404 lb	989 kg	2180 lb

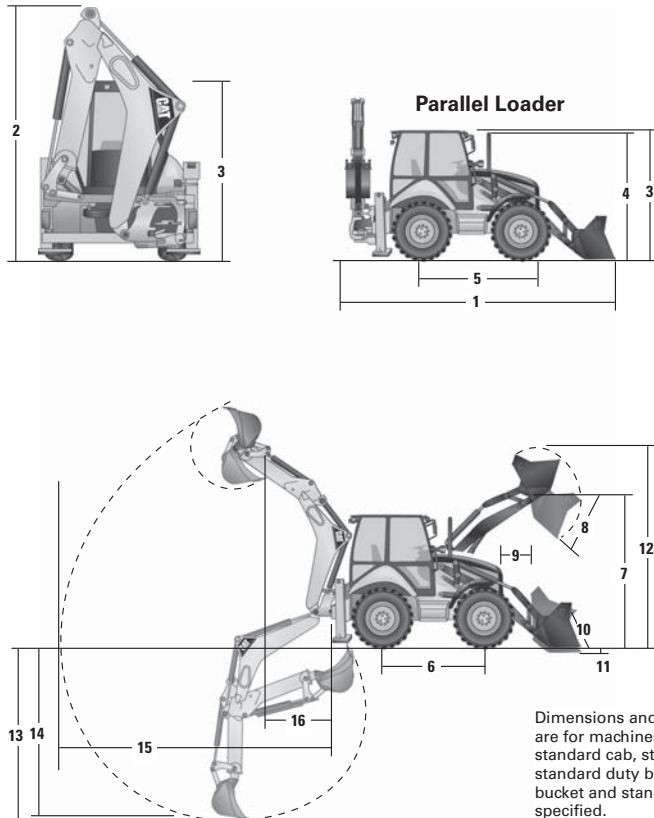

Dimensions and performance specifications shown are for machines equipped with 440/80R28 tires, standard cab, standard stick with 610 mm (24 in) standard duty bucket, and 1.3 m<sup>3</sup> (1.7 yd<sup>3</sup>) MP loader bucket and standard equipment unless otherwise specified.

BACKHOE DIMENSIONS AND PERFORMANCE	Standard Stick		Extendible Stick Retracted 4264 mm (14'0")		Extendible Stick Extended 4264 mm (14'0")	
	13) Digging depth, manufacturers maximum	4738 mm	15'7"	4743 mm	15'7"	5660 mm
14) Digging depth, 610 mm (2'0") flat bottom	4288 mm	14'1"	4291 mm	14'1"	5278 mm	17'4"
15) Reach from swing pivot at ground line	5655 mm	18'7"	5660 mm	18'7"	6586 mm	21'7"
Loading height	3927 mm	12'11"	3938 mm	12'11"	4505 mm	14'9"
16) Loading reach	1808 mm	5'11"	1758 mm	5'9"	2642 mm	8'8"
Swing arc	180°		180°		180°	
Bucket rotation	205°		205°		205°	
Bucket dig force	63.4 kN	14,260 lbf	63.4 kN	14,254 lbf	63.4 kN	14,254 lbf
Stick dig force	42.7 kN	9600 lbf	43.5 kN	9769 lbf	31.6 kN	7112 lbf
Total side shift travel	1258 mm	4'2"	1258 mm	4'2"	1258 mm	4'2"

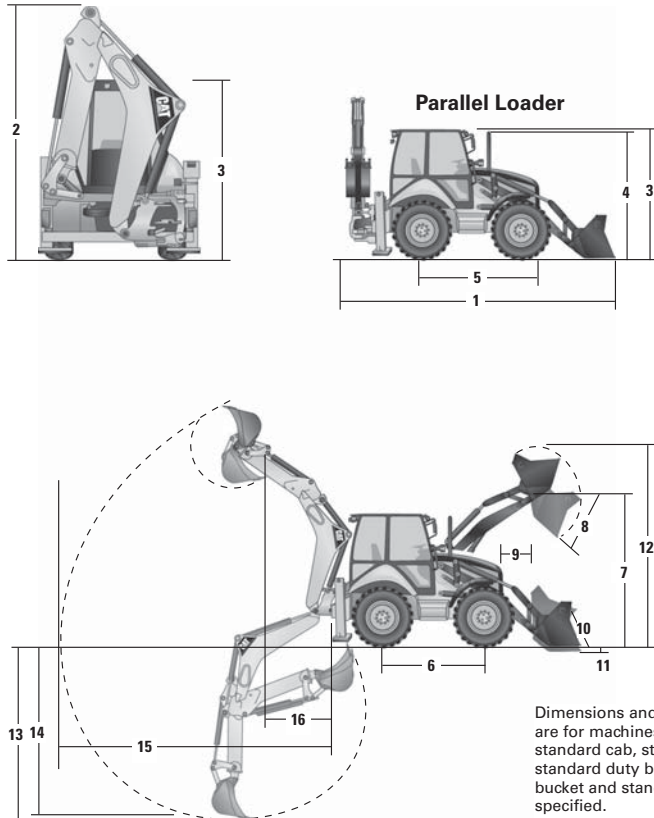

Dimensions and performance specifications shown are for machines equipped with 440/80R28 tires, standard cab, standard stick with 610 mm (24 in) standard duty bucket, and 1.3 m<sup>3</sup> (1.7 yd<sup>3</sup>) MP loader bucket and standard equipment unless otherwise specified.

BACKHOE DIMENSIONS AND PERFORMANCE	Extendible Stick Retracted 4872 mm (16'0")		Extendible Stick Extended 4872 mm (16'0")	
	13) Digging depth, manufacturers maximum	5168 mm	16'11"	6129 mm
14) Digging depth, 610 mm (2'0") flat bottom	4654 mm	15'3"	5671 mm	18'7"
15) Reach from swing pivot at ground line	6132 mm	20'1"	7083 mm	23'3"
Loading height	4495 mm	14'9"	5192 mm	17'0"
16) Loading reach	1696 mm	5'7"	2482 mm	8'2"
Swing arc	180°		180°	
Bucket rotation	205°		205°	
Bucket dig force	63.4 kN	14,256 lbf	63.4 kN	14,256 lbf
Stick dig force	47.2 kN	10,605 lbf	35.1 kN	7887 lbf
Total side shift travel	1258 mm	4'2"	1258 mm	4'2"



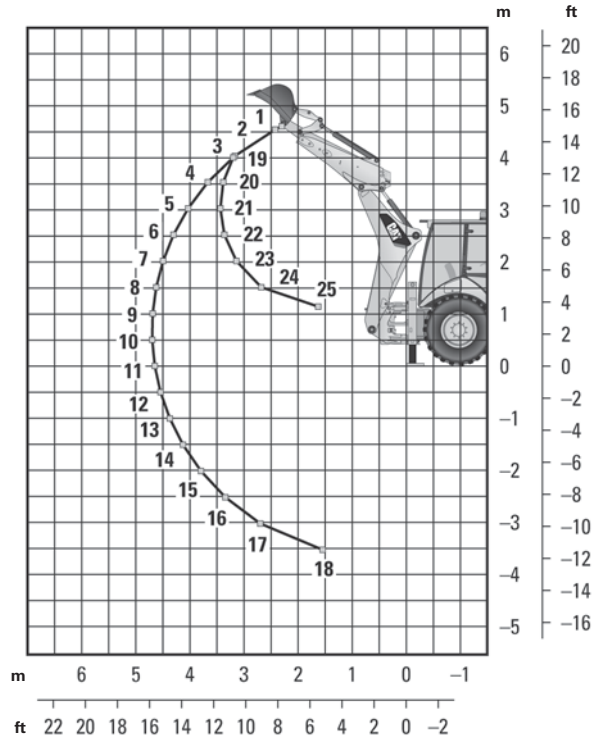

**Standard Stick**

Boom Lifting

1	1407 kg	<b>3096 lb</b>
2	1577 kg	<b>3470 lb</b>
3	1735 kg	<b>3818 lb</b>
4	1774 kg	<b>3903 lb</b>
5	1772 kg	<b>3898 lb</b>
6	1752 kg	<b>3854 lb</b>
7	1724 kg	<b>3794 lb</b>
8	1694 kg	<b>3726 lb</b>
9	1663 kg	<b>3658 lb</b>
10	1632 kg	<b>3591 lb</b>
11	1604 kg	<b>3529 lb</b>
12	1579 kg	<b>3475 lb</b>
13	1559 kg	<b>3430 lb</b>
14	1546 kg	<b>3401 lb</b>
15	1543 kg	<b>3395 lb</b>
16	1563 kg	<b>3438 lb</b>
17	1648 kg	<b>3626 lb</b>
18	2240 kg	<b>4928 lb</b>

Stick Lifting

19	2568 kg	<b>5650 lb</b>
20	2416 kg	<b>5315 lb</b>
21	2392 kg	<b>5263 lb</b>
22	2487 kg	<b>5471 lb</b>
23	2762 kg	<b>6076 lb</b>
24	3591 kg	<b>7899 lb</b>
25	6441 kg	<b>14,169 lb</b>

Lift Capacities are over-end values. Machine equipped with AWD, standard cab, 1.3 m<sup>3</sup> (1.7 yd<sup>3</sup>) multi-purpose bucket, 440/80R28 tires and 0 kg (0 lb) counterweight.

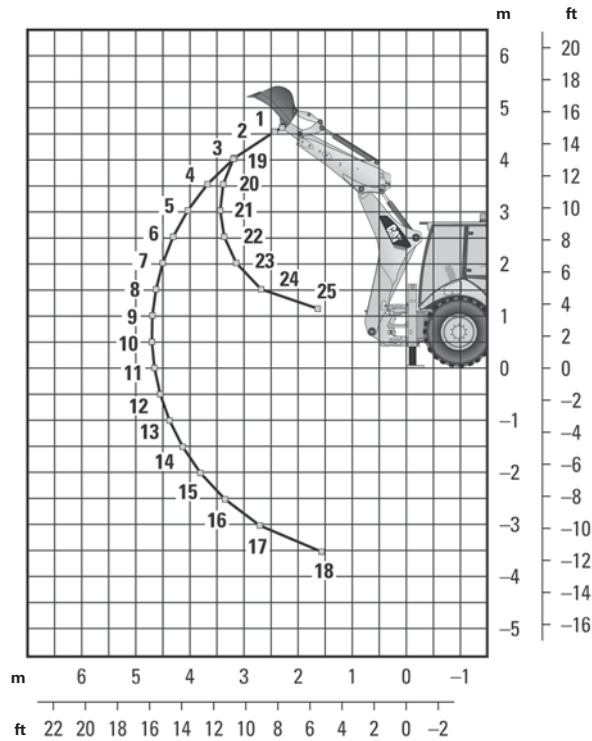

**Extendible Stick Retracted – 4264 mm (14'0")**

Boom Lifting

1	1315 kg	2894 lb
2	1475 kg	3246 lb
3	1612 kg	3546 lb
4	1639 kg	3606 lb
5	1629 kg	3584 lb
6	1604 kg	3529 lb
7	1572 kg	3458 lb
8	1537 kg	3381 lb
9	1502 kg	3304 lb
10	1468 kg	3230 lb
11	1436 kg	3160 lb
12	1407 kg	3096 lb
13	1383 kg	3042 lb
14	1364 kg	3000 lb
15	1354 kg	2979 lb
16	1363 kg	2998 lb
17	1425 kg	3136 lb
18	1904 kg	4189 lb

Stick Lifting

19	2442 kg	5372 lb
20	2289 kg	5037 lb
21	2263 kg	4980 lb
22	2353 kg	5176 lb
23	2618 kg	5759 lb
24	3420 kg	7524 lb
25	6156 kg	13,543 lb

Lift Capacities are over-end values. Machine equipped with AWD, standard cab, 1.3 m<sup>3</sup> (1.7 yd<sup>3</sup>) multi-purpose bucket, 440/80R28 tires and 0 kg (0 lb) counterweight.

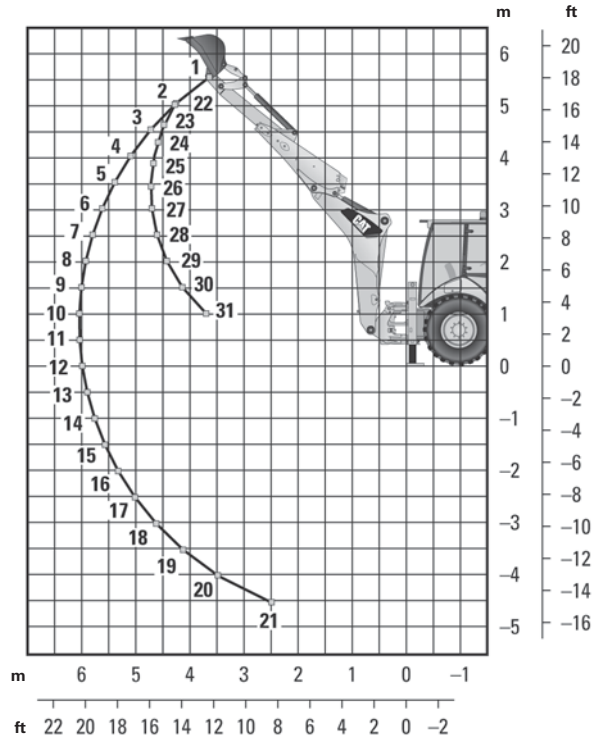

**Extendible Stick Extended – 4264 mm (14'0")**

Boom Lifting

1	799 kg	1757 lb
2	947 kg	2083 lb
3	1089 kg	2396 lb
4	1159 kg	2551 lb
5	1195 kg	2629 lb
6	1212 kg	2666 lb
7	1217 kg	2678 lb
8	1216 kg	2675 lb
9	1211 kg	2663 lb
10	1203 kg	2647 lb
11	1195 kg	2628 lb
12	1186 kg	2610 lb
13	1179 kg	2594 lb
14	1174 kg	2583 lb
15	1172 kg	2579 lb
16	1176 kg	2586 lb
17	1188 kg	2613 lb
18	1216 kg	2674 lb
19	1278 kg	2811 lb
20	1459 kg	3209 lb
21	3786 kg	8329 lb

Stick Lifting

22	1371 kg	3016 lb
23	1627 kg	3579 lb
24	1627 kg	3580 lb
25	1618 kg	3559 lb
26	1648 kg	3625 lb
27	1725 kg	3796 lb
28	1875 kg	4124 lb
29	2166 kg	4765 lb
30	2924 kg	6433 lb
31	7224 kg	15,894 lb

Lift Capacities are over-end values. Machine equipped with AWD, standard cab, 1.3 m<sup>3</sup> (1.7 yd<sup>3</sup>) multi-purpose bucket, 440/80R28 tires and 0 kg (0 lb) counterweight.

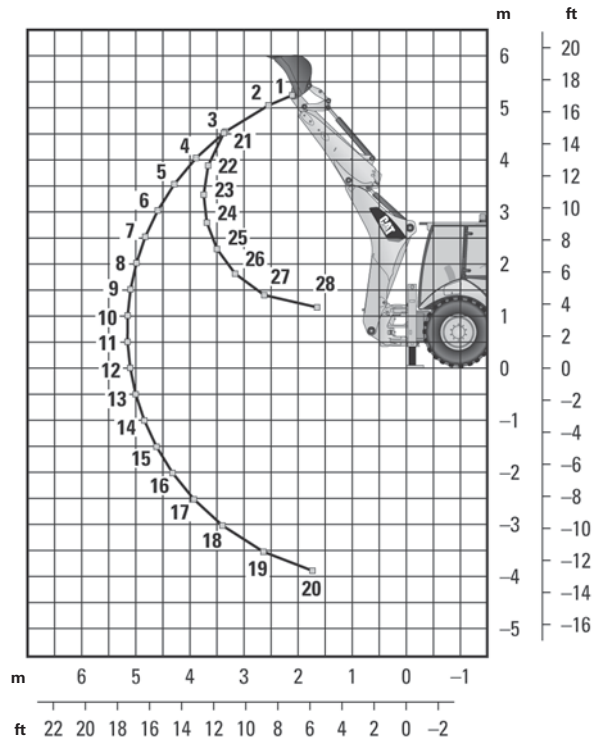

**Extendible Stick Retracted – 4872 mm (16'0")**

Boom Lifting

1	1381 kg	<b>3039 lb</b>
2	1729 kg	<b>3804 lb</b>
3	1920 kg	<b>4224 lb</b>
4	1963 kg	<b>4318 lb</b>
5	1957 kg	<b>4306 lb</b>
6	1932 kg	<b>4250 lb</b>
7	1897 kg	<b>4174 lb</b>
8	1859 kg	<b>4089 lb</b>
9	1819 kg	<b>4002 lb</b>
10	1780 kg	<b>3916 lb</b>
11	1742 kg	<b>3833 lb</b>
12	1707 kg	<b>3756 lb</b>
13	1675 kg	<b>3686 lb</b>
14	1647 kg	<b>3624 lb</b>
15	1624 kg	<b>3573 lb</b>
16	1608 kg	<b>3538 lb</b>
17	1605 kg	<b>3530 lb</b>
18	1625 kg	<b>3576 lb</b>
19	1726 kg	<b>3797 lb</b>
20	1983 kg	<b>4363 lb</b>

Stick Lifting

21	2742 kg	<b>6032 lb</b>
22	2679 kg	<b>5895 lb</b>
23	2598 kg	<b>5716 lb</b>
24	2643 kg	<b>5814 lb</b>
25	2818 kg	<b>6199 lb</b>
26	3200 kg	<b>7040 lb</b>
27	4079 kg	<b>8974 lb</b>
28	6309 kg	<b>13,881 lb</b>

Lift Capacities are over-end values. Machine equipped with AWD, standard cab, 1.3 m<sup>3</sup> (1.7 yd<sup>3</sup>) multi-purpose bucket, 440/80R28 tires and 0 kg (0 lb) counterweight.

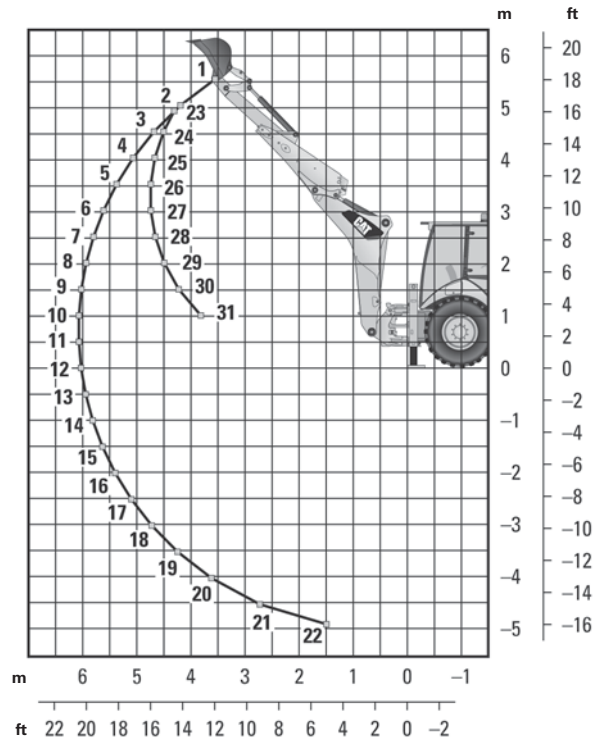

#### Extendible Stick Extended – 4872 mm (16'0")

Boom Lifting

1	1203 kg	2646 lb
2	1362 kg	2997 lb
3	1438 kg	3164 lb
4	1474 kg	3244 lb
5	1490 kg	3277 lb
6	1492 kg	3283 lb
7	1488 kg	3273 lb
8	1478 kg	3252 lb
9	1466 kg	3226 lb
10	1453 kg	3197 lb
11	1440 kg	3168 lb
12	1427 kg	3139 lb
13	1415 kg	3113 lb
14	1406 kg	3092 lb
15	1399 kg	3078 lb
16	1396 kg	3072 lb
17	1401 kg	3081 lb
18	1415 kg	3113 lb
19	1448 kg	3185 lb
20	1523 kg	3350 lb
21	1748 kg	3845 lb
22	2539 kg	5586 lb

Stick Lifting

23	1664 kg	3661 lb
24	1914 kg	4211 lb
25	1953 kg	4297 lb
26	1916 kg	4215 lb
27	1920 kg	4224 lb
28	1966 kg	4325 lb
29	2064 kg	4540 lb
30	2242 kg	4932 lb
31	2577 kg	5669 lb

Lift Capacities are over-end values. Machine equipped with AWD, standard cab, 1.3 m<sup>3</sup> (1.7 yd<sup>3</sup>) multi-purpose bucket, 440/80R28 tires and 0 kg (0 lb) counterweight.

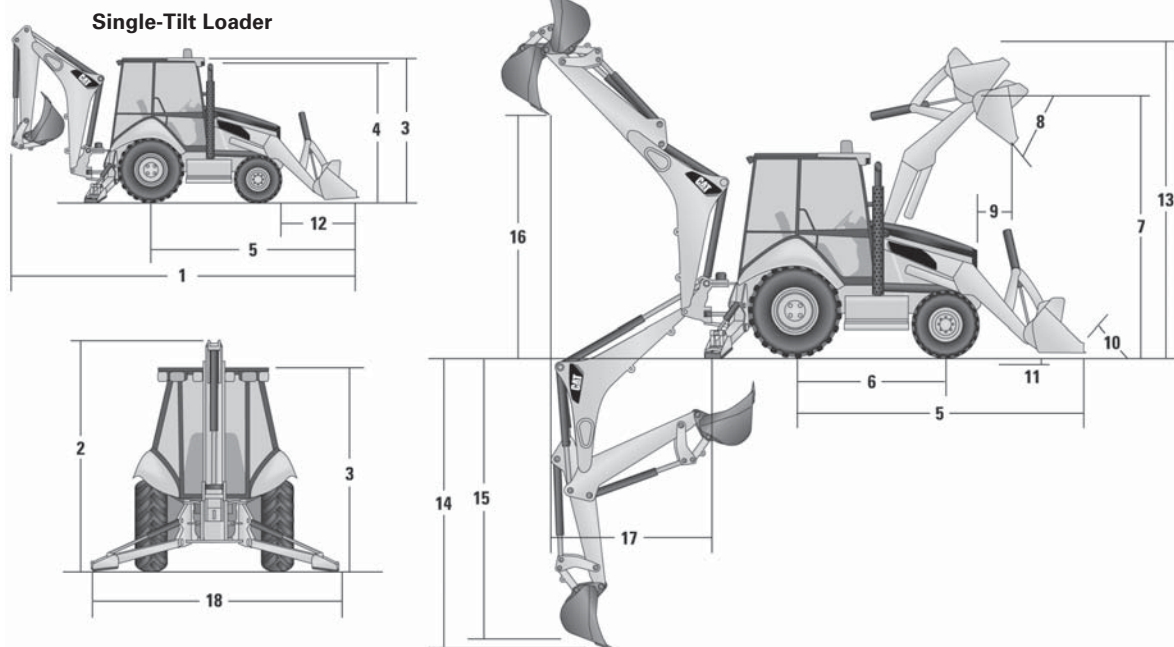

Dimensions and performance specifications shown are for machines equipped with 15-19.5 (12 PR) front tires, 21L-24 (18 PR) rear tires, ROPS canopy, standard stick with 610 mm (24 in) heavy-duty bucket, and 1.3 m<sup>3</sup> (1.7 yd<sup>3</sup>) loader bucket and standard equipment unless otherwise specified.

MACHINE DIMENSIONS	Single-Tilt Loader					
	General Purpose 1.3 m <sup>3</sup> (1.7 yd <sup>3</sup> )		Multi Purpose 1.15 m <sup>3</sup> (1.5 yd <sup>3</sup> )		Multi Purpose with Forks 1.15 m <sup>3</sup> (1.5 yd <sup>3</sup> )	
1) Overall length, loader on ground, standard stick	7913 mm	26'0"	7786 mm	25'7"	7786 mm	25'7"
Overall length, loader on ground, extendible stick	7913 mm	26'0"	7786 mm	25'7"	7786 mm	25'7"
Overall transport length, standard stick	7916 mm	26'0"	7826 mm	25'8"	7826 mm	25'8"
Overall transport length, extendible stick	7916 mm	26'0"	7826 mm	25'8"	7826 mm	25'8"
2) Overall transport height, standard stick	4143 mm	13'7"	4143 mm	13'7"	4143 mm	13'7"
Overall transport height, extendible stick	4159 mm	13'8"	4159 mm	13'8"	4159 mm	13'8"
Overall width	2436 mm	8'0"	2436 mm	8'0"	2436 mm	8'0"
3) Height to top of cab/canopy	2874 mm	9'5"	2874 mm	9'5"	2874 mm	9'5"
4) Height to top of exhaust stack	2845 mm	9'4"	2845 mm	9'4"	2845 mm	9'4"
Rear axle centerline to front grill	2832 mm	9'4"	2832 mm	9'4"	2832 mm	9'4"
Height to loader hinge pin (transport)	469 mm	1'6"	481 mm	1'7"	481 mm	1'7"
Ground clearance (minimum)	322 mm	1'1"	322 mm	1'1"	322 mm	1'1"
5) Rear axle to loader bucket on ground	4494 mm	14'9"	4367 mm	14'4"	4367 mm	14'4"
Front wheel tread gauge	2016 mm	6'7"	2016 mm	6'7"	2016 mm	6'7"
Rear wheel tread gauge	1814 mm	5'11"	1814 mm	5'11"	1814 mm	5'11"
6) Wheelbase	2200 mm	7'3"	2200 mm	7'3"	2200 mm	7'3"

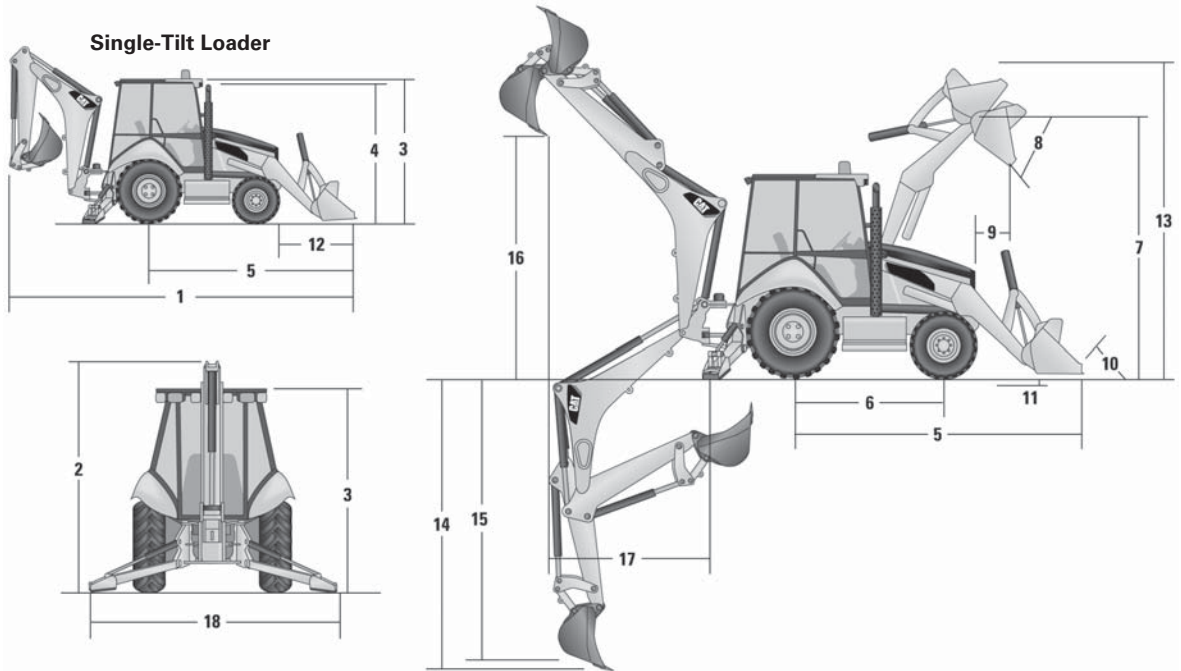

Dimensions and performance specifications shown are for machines equipped with 15-19.5 (12 PR) front tires, 21L-24 (18 PR) rear tires, ROPS canopy, standard stick with 610 mm (24 in) heavy-duty bucket, and 1.3 m<sup>3</sup> (1.7 yd<sup>3</sup>) loader bucket and standard equipment unless otherwise specified.

LOADER BUCKET DIMENSIONS AND PERFORMANCE	Single-Tilt Loader					
	General Purpose 1.3 m <sup>3</sup> (1.7 yd <sup>3</sup> )		Multi Purpose 1.15 m <sup>3</sup> (1.5 yd <sup>3</sup> )		Multi Purpose with Forks 1.15 m <sup>3</sup> (1.5 yd <sup>3</sup> )	
Capacity (SAE) rated	1.3 m <sup>3</sup>	1.7 yd <sup>3</sup>	1.15 m <sup>3</sup>	1.5 yd <sup>3</sup>	1.15 m <sup>3</sup>	1.5 yd <sup>3</sup>
Width	2434 mm	8'0"	2425 mm	7'11"	2425 mm	7'11"
Lift capacity at maximum height	3632 kg	8008 lb	3907 kg	8613 lb	3772 kg	8316 lb
Breakout force	50.7 kN	11,397 lbf	60.9 kN	13,688 lbf	60 kN	13,488 lbf
Tipping load at breakout point	8376 kg	18,466 lb	8160 kg	17,990 lb	8006 kg	17,650 lb
7) Maximum hinge pin height	3501 mm	11'6"	3501 mm	11'6"	3501 mm	11'6"
8) Dump angle at full height		43°		43°		43°
Dump height at maximum angle	2666 mm	8'9"	2759 mm	9'1"	2759 mm	9'1"
9) Dump reach at maximum angle	845 mm	2'9"	774 mm	2'6"	774 mm	2'6"
10) Maximum bucket rollback at ground level		40°		40°		40°
11) Digging depth	146 mm	6"	127 mm	5"	127 mm	5"
Maximum grading angle		106°		109°		109°
Width of dozer cutting edge		N/A	2425 mm	7'11"	2425 mm	7'11"
12) Grill to bucket cutting edge, carry position	1664 mm	5'6"	1571 mm	5'2"	1571 mm	5'2"
13) Maximum operating height	4528 mm	14'10"	4561 mm	15'0"	4881 mm	16'0"
Jaw opening maximum		N/A	864 mm	2'10"	864 mm	2'10"
Bucket jaw clamping force		N/A	39.8 kN	8947 lbf	39.8 kN	8947 lbf
Weight	1132 kg	2495 lb	957 kg	2111 lb	1148 kg	2530 lb

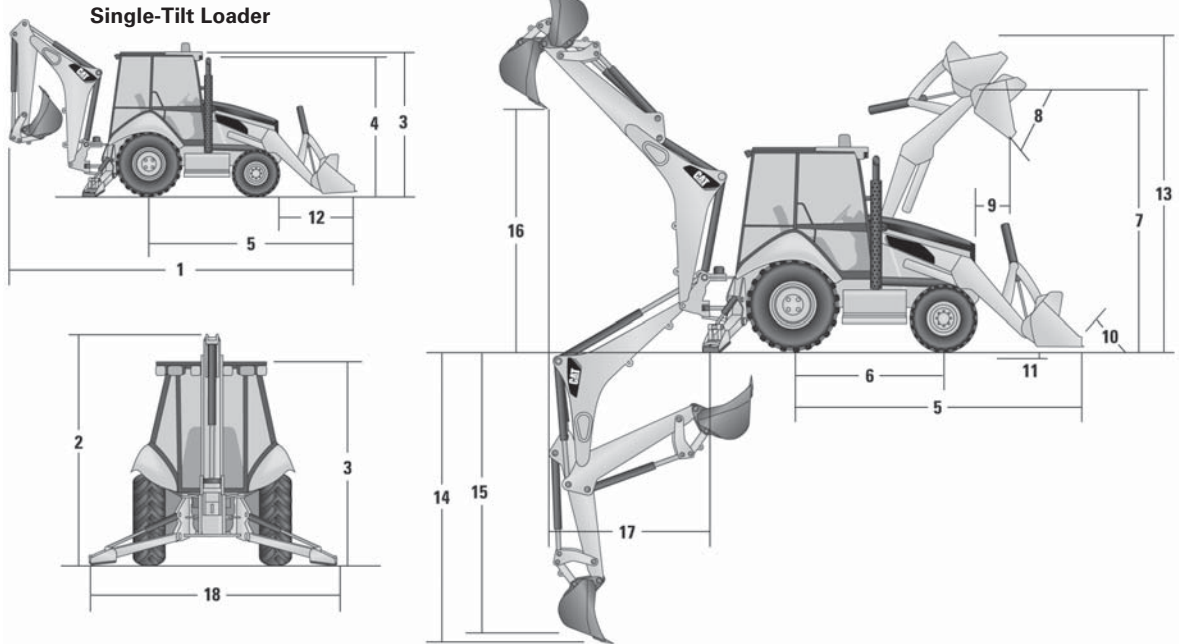

Dimensions and performance specifications shown are for machines equipped with 15-19.5 (12 PR) front tires, 21L-24 (18 PR) rear tires, ROPS canopy, standard stick with 610 mm (24 in) heavy-duty bucket, and 1.3 m<sup>3</sup> (1.7 yd<sup>3</sup>) loader bucket and standard equipment unless otherwise specified.

BACKHOE DIMENSIONS AND PERFORMANCE	Standard Stick		Extendible Stick Retracted		Extendible Stick Extended	
	<b>14)</b> Digging depth, SAE (maximum) Digging depth, 2438 mm (8'0") flat bottom	5260 mm	17'3"	5260 mm	17'3"	6501 mm
<b>15)</b> Digging depth, 610 mm (2'0") flat bottom Reach from rear axle centerline at ground line	4926 mm	16'2"	4926 mm	16'2"	6231 mm	20'5"
<b>16)</b> Reach from swing pivot at ground line Overall operating height Loading height	7949 mm	26'1"	7949 mm	26'1"	9130 mm	29'11"
<b>17)</b> Loading reach Swing arc Bucket rotation	6708 mm	22'0"	6708 mm	22'0"	7890 mm	25'11"
<b>18)</b> Stabilizer spread, operating position (center of pad)	6531 mm	21'5"	6531 mm	21'5"	7375 mm	24'2"
<b>19)</b> Stabilizer spread — operating position (outside edge of pad) Stabilizer spread, transport position Bucket dig force Stick dig force Leveling angle (maximum slope on which machine will make a vertical cut)	4440 mm	14'7"	4440 mm	14'7"	5194 mm	17'0"
	2175 mm	7'2"	2175 mm	7'2"	3200 mm	10'6"
		175°		175°		175°
		198°		198°		198°
	3614 mm	11'10"	3614 mm	11'10"	3614 mm	11'10"
	4055 mm	13'4"	4055 mm	13'4"	4055 mm	13'4"
	2451 mm	8'0"	2451 mm	8'0"	2451 mm	8'0"
	78.9 kN	17,746 lbf	78.9 kN	17,746 lbf	78.9 kN	17,746 lbf
	52.4 kN	11,780 lbf	53.1 kN	11,939 lbf	40.1 kN	9009 lbf
		13°		13°		13°



KEY

- A — Boom lift kg lb
- B — Stick lift kg lb

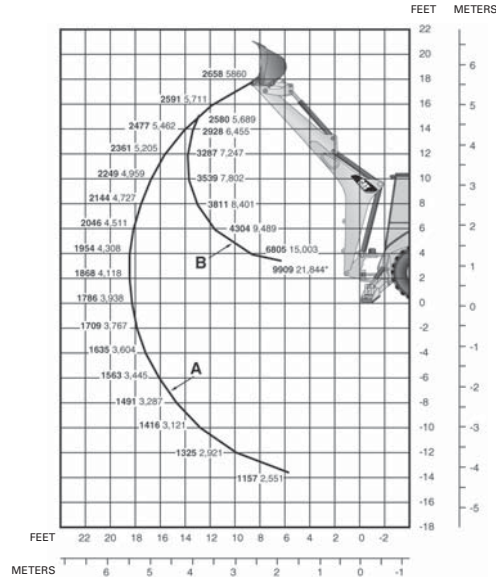

Standard Stick

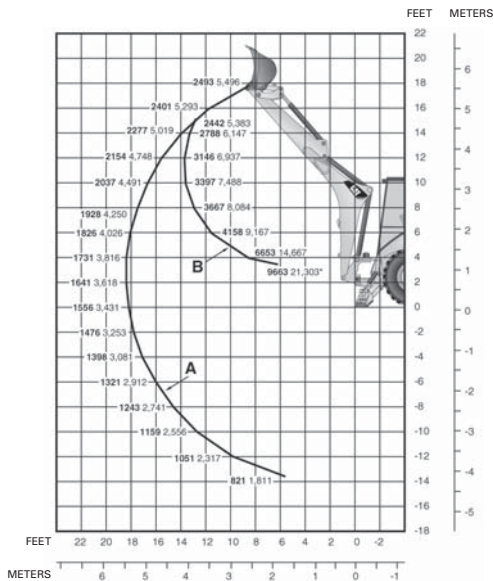

Extendible Stick — Retracted

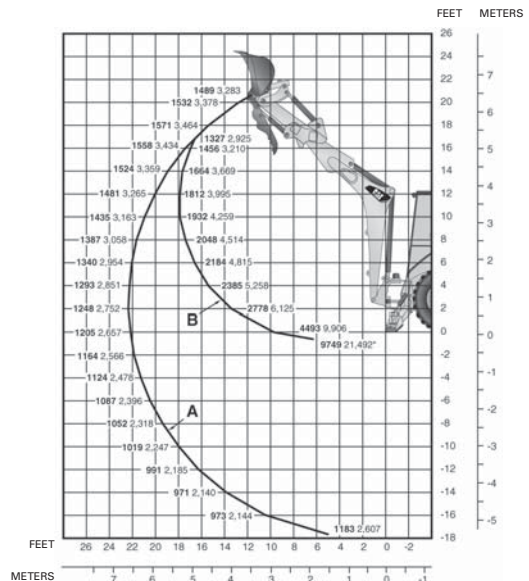

Extendible Stick — Extended

Lift capacities are over-end values per SAE J31; machine equipped with 4WD, OROPS, 1.3 m<sup>3</sup> (1.7 yd<sup>3</sup>) general-purpose loader bucket, 610 mm (24 in) heavy duty backhoe bucket and 985 kg (2200 lb) counterweight.

\*Indicates lift capacity is stability limited.

**Coral Buckets, Pin-on****415F2, 416F2, 420F2, 430F2****(Americas North, Americas South)**

Width		SAE Capacity		Weight		No. of Teeth
mm	in	L	ft <sup>3</sup>	kg	lb	
305	12	65	2.3	123	271	4
457	18	96	3.4	147	324	6
610	24	142	5.0	174	384	8
762	30	190	6.7	200	441	10

**Cribbing Buckets, Pin-on****422F2, 427F2, 428F2, 432F2, 434F2, 444F2****(EAME, APD, Americas South)**

Width		SAE Capacity		Weight		No. of Teeth
mm	in	L	ft <sup>3</sup>	kg	lb	
230	9	60	2.1	145	320	N/A

**Extreme Service Buckets (ES), Pin-on****422F2, 427F2, 428F2, 432F2, 434F2, 444F2****(EAME, APD, Americas South)**

Width		SAE Capacity		Weight		No. of Teeth
mm	in	L	ft <sup>3</sup>	kg	lb	
457	18	130	4.6	138	304	4
610	24	200	7.1	173	381	4

**Ditch Cleaning Buckets, Pin-on****415F2, 416F2, 420F2, 430F2****(Americas North, Americas South)**

Width		SAE Capacity		Weight		No. of Teeth
mm	in	L	ft <sup>3</sup>	kg	lb	
1219	48	368	13.0	205	453	N/A
1372	54	425	15.0	223	491	N/A
1524	60	481	17.0	240	530	N/A

**Ditch Cleaning Buckets****422F2, 427F2, 428F2, 432F2, 434F2, 444F2****(EAME, APD, Americas South)**

Width		SAE Capacity		Weight		No. of Teeth
mm	in	L	ft <sup>3</sup>	kg	lb	
1200	48	200	7.8	123	271	N/A
1400	54	260	9.2	137	302	N/A
1500	60	290	10.2	145	320	N/A
1600	63	310	10.9	152	335	N/A
1800	70	350	12.4	166	366	N/A

**Heavy Duty Buckets (HD), Pin Lock****415F2, 416F2, 420F2, 430F2****(Americas North, Americas South)**

Width		SAE Capacity		Weight		No. of Teeth
mm	in	L	ft <sup>3</sup>	kg	lb	
305	12	96	3.4	113	249	3
406	16	122	4.3	131	288	3
457	18	139	4.9	138	304	4
610	24	207	7.3	168	370	5
762	30	275	9.7	194	428	5
914	36	345	12.2	224	494	6

**Heavy Duty Buckets (HD), Pin-on****415F2, 416F2, 420F2, 422F2, 427F2,****428F2, 430F2, 432F2, 434F2, 444F2****(Americas North, Americas South, EAME, APD)**

Width		SAE Capacity		Weight		No. of Teeth
mm	in	L	ft <sup>3</sup>	kg	lb	
305	12	79	2.8	108	238	3
406	16	105	3.7	127	280	3
457	18	119	4.2	129	284	4
610	24	176	6.2	151	333	5
762	30	232	8.2	167	368	5
914	36	292	10.3	189	417	6

\*Bolt-on teeth available.

**Heavy Duty Buckets (HD), Pin-on  
450F  
(Americas North, Americas South)**

Width		SAE Capacity		Weight		No. of Teeth
mm	in	L	ft <sup>3</sup>	kg	lb	
457	18	178	6.3	207	456	3
610	24	269	9.5	246	542	4
762	30	351	12.4	277	611	4
914	36	439	15.5	319	703	6

**Heavy Duty Rock Buckets (HDR), Pin-on  
415F2, 416F2, 420F2, 430F2  
(Americas North, Americas South)**

Width		SAE Capacity		Weight		No. of Teeth
mm	in	L	ft <sup>3</sup>	kg	lb	
305	12	71	2.5	113	250	3
457	18	130	4.6	138	304	4
610	24	200	7.0	173	381	5
762	30	269	9.5	180	396	5
914	36	326	11.5	205	451	6

**High Capacity Buckets, Pin Lock  
415F2, 416F2, 420F2, 430F2  
(Americas North, Americas South)**

Width		SAE Capacity		Weight		No. of Teeth
mm	in	L	ft <sup>3</sup>	kg	lb	
305	12	130	4.6	130	287	3
406	16	159	5.6	148	327	3
457	18	184	6.5	157	346	4
610	24	272	9.6	188	414	5
762	30	365	12.9	215	475	5
914	36	459	16.2	246	543	6

**High Capacity Buckets, Pin-on  
415F2, 416F2, 420F2, 430F2  
(Americas North, Americas South)**

Width		SAE Capacity		Weight		No. of Teeth
mm	in	L	ft <sup>3</sup>	kg	lb	
457	18	181	6.4	146	322	4
914	36	379	13.4	214	472	6

**Soil Excavation Buckets (SE), Pin-on  
415F2, 416F2, 420F2, 430F2  
(Americas North, Americas South)**

Width		SAE Capacity		Weight		No. of Teeth
mm	in	L	ft <sup>3</sup>	kg	lb	
457	18	181	6.4	152	336	4
610	24	241	8.5	179	395	5
762	30	320	11.3	197	434	5
914	36	379	13.4	223	491	6

**Standard Duty Buckets (SD), Pin-on  
415F2, 416F2, 420F2, 422F2, 427F2,  
428F2, 430F2, 432F2, 434F2, 444F2  
(Americas North, Americas South, EAME, APD)**

Width		SAE Capacity		Weight		No. of Teeth
mm	in	L	ft <sup>3</sup>	kg	lb	
305	12	78	2.8	97	214	3
457	18	118	4.2	115	254	4
610	24	175	6.2	132	291	5
762	30	233	8.2	147	324	5
914	36	292	10.3	165	364	6

Teeth Options: Penetration  
Soil  
Sharp  
Twin Sharp  
Chisel  
Wide  
Long

**Work tools for Cat backhoe loaders are divided into two groups.**  
**For technical questions relating to all work tools inside the U.S.: (800) 282-5384.**  
**Europe, Africa, Middle East: 31 73 63 996 00.**

- **Caterpillar Factory Work Tools:** Cat work tools installed on machines or shipped separately from Caterpillar Distribution Services. Includes the most popular work tools such as buckets, forks and material-handling arms. *Order from Machine Orders Division.*
- **Caterpillar Work Tools America Asia Pacific (AAP):** Cat work tools specifically designed for the Cat backhoe loader by the Caterpillar Work Tool division. *Orders inside U.S.: (800) 255-2372. Outside U.S.: 00 1 (785) 456-2224.*

<b>Loader Work Tools</b>	<b>Auxiliary Hydraulics required</b>
1. IT Angle Blade	Multi-Purpose Hydraulics included with IT not required
2. IT Asphalt Cutter	not required
3. IT Bale Spear	Multi-Purpose Hydraulics included with IT not required
4. IT Broom: Angle and Pick-up*	Multi-Purpose Hydraulics included with IT not required
5. IT Bucket, General Purpose	Multi-Purpose Hydraulics included with IT
6. IT Bucket, Multi-Purpose	Multi-Purpose Hydraulics included with IT
7. IT Bucket, Side-Dump	Multi-Purpose Hydraulics included with IT not required
8. IT Forks, Pallet	not required
9. IT Material Handling Arm	not required
10. IT Rake	not required
11. Quick Coupler, IT Hydraulic	Multi-Purpose Hydraulics not required
12. Single Tilt Bucket, General Purpose	Multi-Purpose Hydraulics includes coupling hydraulics only; can add Multi-Purpose Hydraulics
13. Single Tilt Bucket, Multi-Purpose with or without Fold-Over Forks	
14. Single Tilt Hydraulic Quick Coupler	

\*Requires the IT Auxiliary Attachments Control (electrical wiring harness).

<b>Backhoe Work Tools</b>	<b>Auxiliary Hydraulics required</b>
1. Auger	Combined Function Hydraulics not required
2. Bucket, Cemetery	not required
3. Bucket, Coral	not required
4. Bucket, Ditch Cleaning	not required
5. Bucket, Extreme Service	not required
6. Bucket, Heavy Duty	not required
7. Bucket, Heavy Duty Rock	not required
8. Bucket, High Capacity	not required
9. Bucket, Soil Excavation	not required
10. Bucket, Standard Duty	not required
11. Compactor, Vibratory Plate	One Way or Combined Function Hydraulics
12. Hammer, Hydraulic	One Way or Combined Function Hydraulics not required
13. Quick Coupler, Mechanical Pin-Puller for Cat or Case tools	not required
14. Quick Coupler, Mechanical Pin-Grabber	not required
15. Quick Coupler, Mechanical Pin-Puller for Cat or Deere tools	not required
16. Quick Coupler, Pin Lock	not required
17. Quick Coupler, Side-Tilting Pin Lock	Combined Function Hydraulics not required
18. Ripper	Combined Function Hydraulics not required
19. Thumb, Hydraulic	Combined Function Hydraulics not required
20. Thumb, Mechanical	not required



## CONTENTS

### ROTARY DRILLS

- Product Line Description . . . . .3-2
- Applications/Industries Served . . . . .3-2
- Product Line Chart . . . . .3-3
- Features . . . . .3-4
- Key Specifications . . . . .3-5

### TRACK DRILLS

- Product Line Description . . . . .3-7
- Applications/Industries Served . . . . .3-7
- Product Line Chart . . . . .3-7
- Features . . . . .3-8
- Key Specifications . . . . .3-9
- Shipping Dimensions . . . . .3-10

Throughout this document, references to Tier 4 Interim/Stage IIIB/Japan 2011 (Tier 4 Interim) include U.S. EPA Tier 4 Interim, EU Stage IIIB, and Japan 2011 (Tier 4 Interim) equivalent emission standards. References to Tier 4 Final/Stage IV/Japan 2014 (Tier 4 Final) include U.S. EPA Tier 4 Final, EU Stage IV, and Japan 2014 (Tier 4 Final) emission standards.

Throughout this document, references to Tier 1/Stage I include U.S. EPA Tier 1 and EU Stage I equivalent emission standards. References to Tier 2/Stage II/Japan 2001 (Tier 2) equivalent include U.S. EPA Tier 2, EU Stage II, and Japan 2001 (Tier 2) equivalent emission standards. References to Tier 3/Stage IIIA/Japan 2006 (Tier 3) equivalent include U.S. EPA Tier 3, EU Stage IIIA, and Japan 2006 (Tier 3) equivalent emission standards.

**PRODUCT LINE DESCRIPTION**

Cat® Rotary Drills are available in four models, with a maximum bit load range of up to 63 975 kg (141,000 lb), to suit a wide variety of applications. They’re proven to deliver efficiency, high productivity and low cost, as well as provide a comfortable environment for the operator.

A synergy of robust structures, long-lasting systems and innovative technology, the Cat line of rotary drills have demonstrated their effectiveness and longevity in a variety of mining environments, including both soft- and hard-rock applications, as well as extreme temperature and high-altitude locations.

Equipped to power rotary tricone or claw drill bits of various sizes and configurations, the MD6290 and MD6420C can also be configured with high pressure compressors for DTH (down-the-hole) hammer drilling or even a special (hammer/tricone carousel pipe rack) that accommodates both rotary and DTH drill strings. Caterpillar has the drill that delivers the optimal combination of bit load, rotary torque and onboard air to ensure maximum productivity in a wide range of applications.

**PRIMARY APPLICATIONS FOR ROTARY BLASTHOLE DRILLS**

<b>MODEL</b>	<b>Bench Drilling</b>	<b>Cast Blast Drilling</b>	<b>Presplit Drilling</b>	<b>Grade Control Drilling</b>	<b>Over Burden Drilling</b>
<b>MD6290</b>	x	x	x	x	x
<b>MD6420C</b>	x	x	x	x	x
<b>MD6540C</b>	x	x	x		x
<b>MD6640</b>	x	x			x

MODEL	Hole Diameter	Hole Depth	Air Compressor	Engine
<b>MD6290</b> 8 m 10 m 11 m	• Up to 251 mm <b>(9.875 in)</b>	<ul style="list-style-type: none"> <li>• Depth single-pass (8 m mast) — Up to 8.6 m <b>(28 ft 2 in)</b></li> <li>• Depth multi-pass — Up to 45.1 m <b>(148 ft)</b></li> <li>• Depth single-pass (10 m mast) — Up to 10.1 m <b>(33 ft 2 in)</b></li> <li>• Depth multi-pass — Up to 52.7 m <b>(173 ft)</b></li> <li>• Depth single-pass (11 m mast) — Up to 11 m <b>(36 ft)</b></li> <li>• Depth multi-pass — Up to 32.3 m <b>(106 ft)</b></li> </ul>	<ul style="list-style-type: none"> <li>• 30 m<sup>3</sup>/min <b>(1050 ft<sup>3</sup>/min)</b> 8.6 bar <b>(125 psi)</b></li> <li>• 35.4 m<sup>3</sup>/min <b>(1250 ft<sup>3</sup>/min)</b> @ 8.6 bar <b>(125 psi)</b></li> <li>• 48 m<sup>3</sup>/min <b>(1700 ft<sup>3</sup>/min)</b> 8.6 bar <b>(125 psi)</b></li> <li>• 33 m<sup>3</sup>/min <b>(1150 ft<sup>3</sup>/min)</b> 10.3/24.1 bar <b>(150/350 psi)</b></li> <li>• 38 m<sup>3</sup>/min <b>(1350 ft<sup>3</sup>/min)</b> 10.3/24.1 bar <b>(150/350 psi)</b></li> <li>• 43 m<sup>3</sup>/min <b>(1500 ft<sup>3</sup>/min)</b> 10.3/24.1 bar <b>(150/350 psi)</b></li> </ul>	<ul style="list-style-type: none"> <li>• C15 ACERT™ ** 403 kW <b>(540 hp)</b> at 2100 RPM</li> <li>• C27 ACERT* 597 kW <b>(800 hp)</b> at 2100 RPM</li> <li>• C27 ACERT* 652 kW <b>(875 hp)</b> at 2100 RPM</li> </ul>
<b>MD6420C</b> 10 m 13 m 16 m	• Up to 279 mm <b>(11 in)</b>	<ul style="list-style-type: none"> <li>• Depth single pass (10 m mast) — Up to 10.29 m <b>(33 ft 9 in)</b></li> <li>• Depth multi-pass — Up to 63.40 m <b>(208 ft)</b></li> <li>• Depth single pass (13 m mast) — Up to 13.4 m <b>(44 ft)</b></li> <li>• Depth multi-pass — Up to 74.4 m <b>(244 ft)</b></li> <li>• Depth single pass (16 m mast) — Up to 16.46 m <b>(54 ft)</b></li> <li>• Depth multi-pass — Up to 65.2 m <b>(214 ft)</b></li> </ul>	<ul style="list-style-type: none"> <li>• 56.6 m<sup>3</sup>/min <b>(2000 ft<sup>3</sup>/min)</b> 6.9 bar <b>(100 psi)</b></li> <li>• 73.6 m<sup>3</sup>/min <b>(2600 ft<sup>3</sup>/min)</b> 6.9 bar <b>(100 psi)</b></li> <li>• 42.5 m<sup>3</sup>/min <b>(1500 ft<sup>3</sup>/min)</b> 34.4 bar <b>(500 psi)</b></li> </ul>	<ul style="list-style-type: none"> <li>• C32 Tier 2 680 kW <b>(912 hp)</b> at 1800 RPM</li> <li>• C32* 775 kW <b>(1039 hp)</b> at 1800 RPM</li> </ul>
<b>MD6540C</b> 16 m 20 m	• Up to 349 mm <b>(13.75 in)</b>	<ul style="list-style-type: none"> <li>• Depth single-pass (16 m mast) — Up to 16.15 m <b>(53 ft)</b></li> <li>• Depth multi-pass — Up to 84.91 m <b>(275.3 ft)</b></li> <li>• Depth single pass (20 m mast)</li> <li>• Depth multi-pass — Up to 65.7 m <b>(215.6 ft)</b></li> </ul>	<ul style="list-style-type: none"> <li>• 102 m<sup>3</sup>/min <b>(3600 ft<sup>3</sup>/min)</b> 6.9 bar <b>(100 psi)</b></li> </ul>	<ul style="list-style-type: none"> <li>• Cat 3512* 956.7 kW <b>(1283 hp)</b> at 1800 RPM</li> </ul>
<b>MD6640</b> 19 m 21 m	• Up to 406 mm <b>(16 in)</b>	<ul style="list-style-type: none"> <li>• Depth single-pass — 19.81 m <b>(65 ft)</b></li> <li>• Depth multi-pass — Up to 39.6 m <b>(130 ft)</b></li> <li>• Depth single-pass — 21.3 m <b>(70 ft)</b></li> <li>• Depth multi-pass — Up to 42.7 m <b>(140 ft)</b></li> </ul>	<ul style="list-style-type: none"> <li>• 85 m<sup>3</sup>/min <b>(3000 ft<sup>3</sup>/min)</b> 4.5 bar <b>(65 psi)</b></li> <li>• 107.6 m<sup>3</sup>/min <b>(3800 ft<sup>3</sup>/min)</b> 4.5 bar <b>(65 psi)</b></li> </ul>	<ul style="list-style-type: none"> <li>• AC Induction Motor</li> <li>• Dual Shaft</li> <li>• 447 kW <b>(600 hp)</b></li> <li>• 597 kW <b>(800 hp)</b></li> <li>• 4160V/7200V — 60 Hz</li> <li>• 6600/7200V — 60 Hz</li> <li>• 5500V — 50 Hz</li> <li>• 6600/7200V — 50 Hz</li> <li>• 7200V — 50 Hz</li> </ul>

\*This product meets Tier 2 equivalent emission standards.

\*\*This product meets Tier 3, Stage IIIA, and Japan 2006 (Tier 3) equivalent emission standards.



## CAT ROTARY DRILL FEATURES

### Solid Structures

Heavy-duty structural tubing and box section frames provide exceptional durability.

Caterpillar undercarriages with three-point oscillating suspension, GLT (grease lubricated tracks, double post upper carrier rollers).

### Sturdy Mast

Each model can be configured with various mast lengths to suit specific application requirements for single pass or multi pass drilling.

Designed with double-cut lacing in high stress areas to assure long life, mast structures are made of rectangular ASTM 500 Grade B steel tubing for all main chords, cross members and lacing.

This design ensures a torsionally strong mast structure and reduces deflection and material fatigue.

### Four Jack System

Jack casing assemblies are integrally welded to the main frame providing structural strength and durability and reduce torsional flexing of the main frame.

The four leveling jacks are positioned to provide excellent stability and weight over the hole plus assure four points of contact at all times while drilling.

### HOBO Wrench

The Hydraulically Operated Break Out wrench is part of a highly efficient breakout system that increases speed of pipe changing operations, consequently increasing productivity.

The hydraulic break out wrench is operated from the cab thus protecting the operator.

It also reduces impact loading to the mast and rotary head during pipe changes, further increasing drill mechanical availability.

**NOTE:** MD6640 does not store complete drill string in pipe racks.

### Power Group

Fast cycle times are achieved through top of class bit load, rotary head horsepower, bailing air and a multitude of time-saving systems for maximum efficiency.

### Carousel Pipe Rack Option

All Cat drills are equipped with a pipe rack system.

The carousel pipe rack allows rapid pipe changes safely and efficiently and completely controlled from inside of operator's cab.

On the MD6290 or MD6420C, an optional hammer/tricone carousel allows the operator to rack a complete drill string (with either DTH hammer and bit, or tricone bit) in the carousel.

This flexibility allows the operator to change drilling method as quickly as removing or adding a standard drill pipe.

### Ergonomic Cab

The FOPS certified operator's cab features well organized controls, ergonomic operators seat and climate control.

The cab is sound and thermally insulated keeping noise levels low and the operator safe and comfortable.

### Dust Control System

Part of the stationary rear drill deck, the dust chamber with heavy duty rubber dust curtains and optional hydraulic lifters front and rear, assures (no visible emission) dust containment.

Dust chambers are designed with ample space for deep hole drilling to capture material flushing from the hole and build the resulting cuttings pile.

MODEL	MD6290	MD6420C
Hole Diameter	<ul style="list-style-type: none"> <li>Up to 244 mm (<b>9.625 in</b>)</li> </ul>	<ul style="list-style-type: none"> <li>Up to 279.4 mm (<b>11 in</b>)</li> </ul>
Hole Depth	<ul style="list-style-type: none"> <li>Depth single-pass (8 m mast) – Up to 8.6 m (<b>28 ft 2 in</b>)</li> <li>Depth multi-pass – Up to 45.1 m (<b>148 ft</b>)</li> <li>Depth single-pass (10 m mast) – Up to 10.1 m (<b>33 ft 2 in</b>)</li> <li>Depth multi-pass – Up to 52.7 m (<b>173 ft</b>)</li> <li>Depth single-pass (11 m mast) – Up to 11 m (<b>36 ft</b>)</li> <li>Depth multi-pass – Up to 32.3 m (<b>106 ft</b>)</li> </ul>	<ul style="list-style-type: none"> <li>Depth single pass (10 m mast) – Up to 10.29 m (<b>33 ft 9 in</b>)</li> <li>Depth multi-pass – Up to 63.40 m (<b>208 ft</b>)</li> <li>Depth single pass (13 m mast) – Up to 13.4 m (<b>44 ft</b>)</li> <li>Depth multi-pass – Up to 74.4 m (<b>244 ft</b>)</li> <li>Depth single pass (16 m mast) – Up to 16.46 m (<b>54 ft</b>)</li> <li>Depth multi-pass – Up to 46.9 m (<b>154 ft</b>)</li> </ul>
Compressor	<ul style="list-style-type: none"> <li>30 m<sup>3</sup>/min (<b>1050 ft<sup>3</sup>/min</b>) 8.6 bar (<b>125 psi</b>)</li> <li>35 m<sup>3</sup>/min (<b>1250 ft<sup>3</sup>/min</b>) 8.6 bar (<b>125 psi</b>)</li> <li>48 m<sup>3</sup>/min (<b>1700 ft<sup>3</sup>/min</b>) 8.6 bar (<b>125 psi</b>)</li> <li>33 m<sup>3</sup>/min (<b>1150 ft<sup>3</sup>/min</b>) 10.3/24.1 bar (<b>150/350 psi</b>)</li> <li>38 m<sup>3</sup>/min (<b>1350 ft<sup>3</sup>/min</b>) 10.3/24.1 bar (<b>150/350 psi</b>)</li> <li>43 m<sup>3</sup>/min (<b>1500 ft<sup>3</sup>/min</b>) 10.3/24.1 bar (<b>150/350 psi</b>)</li> </ul>	<ul style="list-style-type: none"> <li>56.6 m<sup>3</sup>/min (<b>2000 ft<sup>3</sup>/min</b>) 6.9 bar (<b>100 psi</b>)</li> <li>73.6 m<sup>3</sup>/min (<b>2600 ft<sup>3</sup>/min</b>) 6.9 bar (<b>100 psi</b>)</li> <li>42.5 m<sup>3</sup>/min (<b>1500 ft<sup>3</sup>/min</b>) 10.3/24.1/34.4 bar (<b>150/350/500 psi</b>)</li> </ul>
Cooler (ambient rating)	<ul style="list-style-type: none"> <li>52° C (<b>125° F</b>)</li> </ul>	<ul style="list-style-type: none"> <li>52° C (<b>125° F</b>)</li> </ul>
Engine	<ul style="list-style-type: none"> <li>C15 ACERT** <ul style="list-style-type: none"> <li>– 403 kW (<b>540 hp</b>) at 2100 RPM</li> </ul> </li> <li>C27 ACERT* <ul style="list-style-type: none"> <li>– 597 kW (<b>800 hp</b>) at 2100 RPM</li> </ul> </li> <li>C27 ACERT* <ul style="list-style-type: none"> <li>– 652 kW (<b>875 hp</b>) at 2100 RPM</li> </ul> </li> </ul>	<ul style="list-style-type: none"> <li>C32 Tier 2 <ul style="list-style-type: none"> <li>– 680 kW (<b>912 hp</b>) at 1800 RPM</li> </ul> </li> <li>C32* <ul style="list-style-type: none"> <li>– 775 kW (<b>1039 hp</b>) at 1800 RPM</li> </ul> </li> </ul>
Cab	<ul style="list-style-type: none"> <li>FOPS</li> </ul>	<ul style="list-style-type: none"> <li>FOPS</li> </ul>
Fuel Tank	<ul style="list-style-type: none"> <li>2461 L (<b>650 U.S. gal</b>)</li> </ul>	<ul style="list-style-type: none"> <li>3217 L (<b>850 U.S. gal</b>)</li> </ul>
Hydraulic Tank	<ul style="list-style-type: none"> <li>644 L (<b>170 U.S. gal</b>)</li> </ul>	<ul style="list-style-type: none"> <li>1208 L (<b>319 U.S. gal</b>)</li> </ul>
Pipe Rack	<ul style="list-style-type: none"> <li>Outside Mast Carousel, with stationary breaker plates</li> </ul>	<ul style="list-style-type: none"> <li>Inside Mast Carousel, with stationary pods and breaker plates</li> </ul>
Drill Pipe Capacity	<ul style="list-style-type: none"> <li>Diameter 114 to 178 mm (<b>4.5 to 7 in</b>)</li> <li>8 m mast <ul style="list-style-type: none"> <li>4 pods: <ul style="list-style-type: none"> <li>– 9.14 m (<b>30 ft</b>) pipe</li> </ul> </li> </ul> </li> <li>10 m mast <ul style="list-style-type: none"> <li>4 pods: <ul style="list-style-type: none"> <li>– 10.67 m (<b>35 ft</b>) pipe</li> </ul> </li> </ul> </li> <li>11 m mast <ul style="list-style-type: none"> <li>2 pods: <ul style="list-style-type: none"> <li>– 9.14 m (<b>30 ft</b>) or</li> <li>– 10.67 m (<b>35 ft</b>) pipe</li> </ul> </li> </ul> </li> </ul>	<ul style="list-style-type: none"> <li>10 m configuration <ul style="list-style-type: none"> <li>5 pipes: <ul style="list-style-type: none"> <li>– 10.67 m (<b>35 ft</b>) pipe</li> <li>– 194 mm (<b>7.625 in</b>) OD</li> </ul> </li> </ul> </li> <li>13 m configuration <ul style="list-style-type: none"> <li>5 pipes: <ul style="list-style-type: none"> <li>– 12.19 m (<b>40 ft</b>) pipe</li> <li>– 194 mm (<b>7.625 in</b>) OD</li> </ul> </li> </ul> </li> <li>16 m configuration <ul style="list-style-type: none"> <li>4 pipes: <ul style="list-style-type: none"> <li>– 7.62 m (<b>25 ft</b>) pipe</li> <li>– 219 mm (<b>8.625 in</b>) OD</li> </ul> </li> </ul> </li> </ul>
Tram Speed Maximum	<ul style="list-style-type: none"> <li>3.14 km/h (<b>1.95 mph</b>)</li> </ul>	<ul style="list-style-type: none"> <li>2.27 km/h (<b>1.41 mph</b>)</li> </ul>
Angle Hole Drilling	<ul style="list-style-type: none"> <li>Up to 25 degree off vertical, in 5 degree increments</li> </ul>	<ul style="list-style-type: none"> <li>Up to 30 degree off vertical, in 5 degree increments</li> </ul>

\*This product meets Tier 2 equivalent emission standards.

\*\*This product meets Tier 3, Stage IIIA, and Japan 2006 (Tier 3) equivalent emission standards.

MODEL	MD6540C	MD6640
Hole Diameter	• Up to 349 mm ( <b>13.75 in</b> )	• Up to 406 mm ( <b>16 in</b> )
Hole Depth	<ul style="list-style-type: none"> <li>• Depth single-pass (16 m mast) – Up to 16.15 m (<b>53 ft</b>)</li> <li>• Depth multi-pass – Up to 84.91 m (<b>275.3 ft</b>)</li> <li>• Depth single pass (20 m mast) – Up to 19.8 m (<b>65 ft</b>)</li> <li>• Depth multi-pass – Up to 65.5 m (<b>215 ft</b>)</li> </ul>	<ul style="list-style-type: none"> <li>• Depth single-pass 19.81 m (<b>65 ft</b>)</li> <li>• Depth multi-pass up to 39.6 m (<b>130 ft</b>)</li> <li>• Depth dingle-pass 21.3 m (<b>70 ft</b>)</li> <li>• Depth multi-pass up to 42.7 m (<b>140 ft</b>)</li> </ul>
Compressor	• 102 m <sup>3</sup> /min ( <b>3600 ft<sup>3</sup>/min</b> ) 6.9 bar ( <b>100 psi</b> )	<ul style="list-style-type: none"> <li>• 85 m<sup>3</sup>/min (<b>3000 ft<sup>3</sup>/min</b>) 4.5 bar (<b>65 psi</b>)</li> <li>• 107.6 m<sup>3</sup>/min (<b>3800 ft<sup>3</sup>/min</b>) 4.5 bar (<b>65 psi</b>)</li> </ul>
Cooler (ambient rating)	• 52° C ( <b>125° F</b> )	• 50° C ( <b>122° F</b> )
Engine	• Cat 3512* – 956.7 kW ( <b>1283 hp</b> ) at 1800 RPM	–
Main Motor	–	<ul style="list-style-type: none"> <li>• AC Induction Motor</li> <li>• Dual Shaft</li> <li>• 447 kW (<b>600 hp</b>) or 597 kW (<b>800 hp</b>)</li> <li>• 4160/6600/7200V – 60 Hz</li> <li>• 5500/6600/7200V – 50 Hz</li> </ul>
Cab	• FOPS	• FOPS
Fuel Tank	• Total 3289 L ( <b>869 U.S. gal</b> )	• Not applicable
Hydraulic Tank	• 1389 L ( <b>367 U.S. gal</b> )	• 507 L ( <b>134 U.S. gal</b> )
Pipe Rack	• Inside Mast Carousel, with stationary pods and breaker plates	• Single Rack; or Dual pipe rack available. Both located inside of mast and swing out in line with drill string
Drill Pipe Capacity	<ul style="list-style-type: none"> <li>• 16 m mast: <ul style="list-style-type: none"> <li>– 13.7 m (<b>45 ft</b>) pipe</li> <li>– 219 mm (<b>8.625 in</b>) through 273 mm (<b>10.75 in</b>) OD (5 each)</li> </ul> </li> <li>• 20 m mast: <ul style="list-style-type: none"> <li>9.1 m (<b>30 ft</b>) pipe</li> <li>– 219 mm (<b>8.625 in</b>) and 273 mm (<b>10.75 in</b>) OD (4 each)</li> </ul> </li> </ul> <p><b>NOTE:</b> 219 mm (<b>8.625 in</b>) and 235 mm (<b>9.25 in</b>) 5 pod pipe rack. 273 mm (<b>10.75 in</b>) has 4 pod pipe rack.</p>	<ul style="list-style-type: none"> <li>• 19.81 m (<b>65 ft</b>) mast 2 pods: – 9.90 m (<b>32.5 ft</b>) pipe (2 pipes per pod)</li> <li>or</li> <li>• 21.3 m (<b>70 ft</b>) mast 2 pods: – 10.66 m (<b>35 ft</b>) pipe (2 pipes per pod)</li> <li>• 235 to 340 mm (<b>9.25 to 13.375 in</b>) OD pipe</li> <li>• Single or double pipe racks</li> </ul>
Tram Speed Maximum	• 2.09 km/h ( <b>1.03 mph</b> )	• 1.77 km/h ( <b>1.1 mph</b> )
Angle Hole Drilling	• Up to 30 degree off vertical, in 5 degree increments	• Up to 25 degree off vertical, in 5 degree increments

\*This product meets Tier 2 equivalent emission standards.

## PRODUCT LINE DESCRIPTION

Cat Track Drills are designed for optimum performance and serviceability, while maintaining the ruggedness and reliability our customers have come to expect. With an industry-leading rock drill that can be serviced right on the feed, our customers can enjoy higher uptime and lower maintenance cost as a result of owning Cat Track Drills. Track drills are for use in mining, construction and quarry applications.

## PRIMARY APPLICATIONS FOR TRACK DRILLS IN MINING, QUARRIES AND CONSTRUCTION

MODEL	Pipeline	Pioneering	Basements	Tie Bolting	Trenching	Site Prep	Highway Road Cut	Hydro Electric	Wind Farm	Prod Drill – Small Q & M	Prod Drill – Medium Q & M	Prod Drill – Large Q & M	Wall Control	Presplit
MD5075C						x	x	x	x	x	x		x	x
MD5150C							x	x	x	x	x	x	x	x

## PRODUCT LINE CHART

MODEL	Hole Diameter	Hole Depth	Air Compressor	Rock Drill	Engine
MD5075C	• Up to 114.3 mm (4.5 in)	• Up to 31.2 m (102.5 ft)	• 9.9 m <sup>3</sup> /min @ 10.2 bar (350 ft <sup>3</sup> /min @ 150 psi)	• HPR5123 23 kW (31 hp)	• Cat C9 ACERT* 224 kW (300 hp) at 1800 RPM
MD5150C	• Up to 152 mm (6 in)	• Up to 31.2 m (102.5 ft)	• 15.1 m <sup>3</sup> /min @ 9.6 bar (534 ft <sup>3</sup> /min @ 140 psi)	• HPR5128 28 kW (37 hp)	• Cat C11 ACERT* 287 kW (385 hp) at 1800 RPM

\*This product meets Tier 3, Stage IIIA, and Japan 2006 (Tier 3) equivalent emission standards.

## CAT TRACK DRILL FEATURES

Used in construction, quarry, and mining applications providing effective drilling capabilities and high productivity.

### Industry-leading Rock Drill

The top sales features: Cat Rock Drills are powered matched to application, simple and durable, they have long service intervals, short service hours, 25k hour life cycle and are 100 percent serviceable on the feed. With three times the lifespan and less than one half the parts cost of competitive rock drills, you cannot overlook the value of the Cat Rock Drill for reaching maximum uptime at low total cost of ownership.

### Robust Extension Boom

The sturdy boom and feed support the Carousel Rod Changer for thousands of hours of trouble-free operation. The 2.7 m (9 ft) boom extends an additional 0.9 m (3 ft) for larger pattern coverage with fewer set ups.

### Carousel Rod Changer is Fast and Electronics-free

Cat Carousel Rod Changers are fast with a reliable mechanical design with no sensitive electronic sensors that cause excessive downtime.

Cat Track Drills' carousel rod-handling system is 100 percent electronics-free. Everything is mechanical for maximum uptime and easier troubleshooting.

### Ergonomic Cab Design

Cat Track Drills have cabs with rollover and falling object protection, excellent visibility, and responsive controls that minimize fatigue. Some cabs are designed for front window push-out, which offers a second exit for the operator in case of emergency. The cab is also equipped with an emergency stop for immediate shutdown.

### Sturdy Frame

You can rely on a maintenance free and long lasting frame for your drill.

- High quality steel
- Welds are magnetic particle inspected
- Vibratory stress tested
- Designed to our best-built standards

### Cat Rock Drill Advantage

Cat Rock Drills are power matched to the application for energy-efficient drilling. They are simple and durable, with extended service intervals, and service on the feed is quick. Major components are designed to last the life of the machine, and Caterpillar is the only manufacturer that offers rock drills that can be serviced on-site. With triple the lifespan and less than one-half of the parts costs of competitive rock drills, you cannot overlook the value of a Cat Rock Drill for reaching maximum uptime and low costs.

### Rock Drills That Are Owner Serviceable

Owner-serviceable rock drills yield a significant cost savings as others require downtime for round trip transportation to a clean room environment for service. With Cat Rock Drills, stocking multiple or back up rock drills is not required and all maintenance can be done in your shop and even on the feed including, and up to, a major rebuild.

### Rock Drill Service Cost Advantage

Cat Rock Drills require 3.5 times less service hours per year because they are robust and require fewer service intervals. Each service takes only half of the time of other rock drills due to simplistic design with four housings and only half of the internal parts of other brands. Overall the Cat Rock Drills service cost is 60 percent less than competitive models year over year.

MODEL	MD5075C	MD5150C
Hole Diameter	• Up to 114.3 mm (4.5 in)	• Up to 152.4 mm (6.0 in)
Hole Depth	• Up to 31.2 m (102.5 ft)	• Up to 31 m (102.5 ft)
Rock Drill Power*	• 23 kW (31 hp)	• 28 kW (38 hp)
Compressor	• 9.9 m <sup>3</sup> /min (350 ft <sup>3</sup> /min)	• 15.1 m <sup>3</sup> /min (534 ft <sup>3</sup> /min)
Cooler	• 52° C (125° F)	• 52° C (125° F)
Engine	• Cat C9 ACERT,** electronically controlled, 6-cylinder inline turbocharged, water-cooled, 224 kW (300 bhp) at 1800 RPM	• Cat C11 ACERT,** electronically controlled, 6-cylinder inline turbocharged, water-cooled, 287 kW (385 bhp) at 1800 RPM
Cab	• ROPS/FOPS	• ROPS/FOPS
Fuel Tank	• 492 L (130 U.S. gal)	• 618 L (163.3 U.S. gal)
Hydraulic Tank	• 405 L (107 U.S. gal)	• 416 L (110 U.S. gal)
Boom Length	• 3.81 m (12.5 ft) with 1.5 m (5.0 ft) telescopic extension	• 2.7 m (9 ft) with 0.9 m (3 ft) telescopic extension
Rod Changer	• Carousel with 6 rods × 3.66 m (12 ft) or 6 rods × 4.27 m (14 ft)	• Carousel with 6 rods × 3.66 m (12 ft) or 6 rods × 4.27 m (14 ft)
Drill Steel Diameter	• 45 or 51 mm (1.75 or 2 in) steel	• 51, 60 or 68 mm (2, 2.34 or 2.68 in) steel
Ground Clearance	• 380 mm (15 in)	• 406 mm (16 in)
Tram Speed Max.	• 4 km/h (2.5 mph)	• 4.02 km/h (2.5 mph)
Track Oscillation	• ±10°	• ±11°

\*Each model can take multiple sizes of rock drills and drill steel. Standard is listed.

\*\*This product meets Tier 3, Stage IIIA, and Japan 2006 (Tier 3) equivalent emission standards.

**SHIPPING DIMENSIONS**

<b>MODEL</b>	<b>MD5075C</b>		<b>MD5150C</b>	
Length	12.3 m	<b>40.4 ft</b>	10.66 m	<b>35 ft</b>
Width	2.6 m	<b>8.6 ft</b>	2.64 m	<b>8 ft 6.55 in</b>
Height	3.4 m	<b>11.3 ft</b>	3.5 m	<b>11 ft 7.33 in</b>
Weight	19 504 kg	<b>43,000 lb</b>	22 680 kg	<b>50,000 lb</b>

## CONTENTS

Design Data . . . . .	4-2
Rating Explanations . . . . .	4-2
Basic Specifications . . . . .	4-3
MaK™ Marine Propulsion Engines . . . . .	4-5
Rental Generator Sets . . . . .	4-8
Cat® Generator Sets . . . . .	4-9, 4-13
MaK Marine Generator Sets . . . . .	4-11
Cat Marine Engines . . . . .	4-17
Cat Industrial Diesel Applications . . . . .	4-21
Cat Oil and Gas Engines . . . . .	4-31
Cat Railway Power . . . . .	4-39

**Asia**  
**Caterpillar Asia Pte., Ltd.**  
 Jurong, Singapore  
 Tel: 65-6828-7118  
 Fax: 65-6828-7414

**Australia**  
**Caterpillar of Australia Pty. Ltd.**  
 Victoria, Australia  
 Tel: 61-3-9953-9301  
 Fax: 61-3-9338-9021

**China**  
**Caterpillar China Ltd.**  
 Beijing, China  
 Tel: 86-10-5921-0339  
 Fax: 86-10-5921-0022

**Eastern Europe Commonwealth of Independent States**  
**Caterpillar Overseas S.A.**  
 Moscow, Russia  
 Tel: 7-095-755-8161  
 Fax: 7-095-785-5688

**Europe, Africa, Middle East**  
**Caterpillar S.A.R.L.**  
 Geneva, Switzerland  
 Tel: 41-22-849-4444  
 Fax: 41-22-849-4139

**Japan**  
**Caterpillar Power Systems, Inc.**  
 Tokyo, Japan  
 Tel: 81-3-5786-3800  
 Fax: 81-3-5786-3809





**Mexico, The Caribbean, South America Latin America Commercial Division**  
 Miami, Florida, U.S.A.  
 Tel: 305-476-6800  
 Fax: 305-476-6850

**North America**  
**Caterpillar Inc.**  
 Peoria, Illinois, U.S.A.  
 Tel: 309-578-6298  
 Fax: 309-578-2559

**E Mail:**  
 Cat\_Power@Cat.com

**Web Site/Dealer Locator**  
[www.Cat-engines.com](http://www.Cat-engines.com)

For more information contact your local Cat dealer, or visit the Cat engine and generator set website on [www.cat-engines.com](http://www.cat-engines.com).

	TYPE	NO. OF MODELS	RANGE
	<b>INDUSTRIAL Diesel</b>	54	8.2 to 4920 kW 11.0 to 6598 hp
	<b>Gaseous Fueled</b>	14	71 to 6100 kW 95 to 8180 hp
	<b>GENERATOR SETS Diesel High Speed Area</b>		50 Hz kVA w/fan Prime 6.8-3600 Standby 7.5-4000 60 Hz ekW w/fan Prime 6.8-3600 Standby 7.5-4000
	<b>Gaseous Fueled</b>		50 Hz ekW w/o fan Continuous 66-9700 60 Hz ekW w/o fan Continuous 235-9700
	<b>MARINE Propulsion</b>	23	93 to 5650 kW 125 to 7577 bhp
	<b>Generator Sets</b>	16	50 Hz kVA 10.0 to 6500 Prime 60 Hz kW 12.0 to 4840 Prime
	<b>POWER AND PRODUCTION Generator Sets</b>	28	50 Hz 1140 to 18 000 kW Prime 1529 to 24,138 hp Prime 60 Hz 1020 to 18 000 kW 1368 to 24,138 hp
	<b>Pump Application</b>	11	1140 to 6100 kW 1529 to 8180 hp

**NOTE:** For specific emission standards per model and rating, please see pages 4-21 through 4-22.



**DESIGN DATA\*****Diesel Engines**

*Bearings* — Precision-type steel-backed aluminum alloy with lead-tin overlay copper bonded to bearing surface. High load carrying ability and exceptional fatigue strength.

*Block* — Cast from high tensile strength grey iron. Internal ribbing provides added strength.

*Cooling* — Built-in, gear driven centrifugal pump circulates jacket water through engine at all times. Water temperature is thermostatically controlled. Heat exchangers and radiators are available.

*Crankshaft* — Forged steel, dynamically balanced, heat treated and superfinished.

*Cylinder Liners* — Internal surface induction hardened (1.7 L, 3300, 3400, 3500 and 3600 Families) for excellent wear life. Full-length watercooled for efficient heat transfer.

*Fuel System* — Adjustment free for reduced engine maintenance, individual fuel injection pumps have built-in calibration — no adjustment required after fuel nozzle replacement (1.7 L, 1.9 L, 3406E, 3456, 3500 and 3600 families have unit injectors). 3126, 3408E and 3412E use the Cat HEUI™ system.

*Governor* — Hydra-mechanical (Woodward 3161 on 3500 and 3600 Families) for reliability, good response and smooth, stable load changes. Electronically controlled engines use Caterpillar proprietary software and hardware.

*Lubrication* — Positive displacement gear pump maintains continuous flow of lubricant under pressure to all moving parts. Full-flow filtration is provided by replaceable cellulose filters. Watercooled oil cooler maintains proper oil temperature.

*Pistons* — Three-ring design (two-ring on 3208) reduces friction, provides excellent oil control, and increases engine efficiency.

*Starting* — Electric and air starting systems are offered for most models.

*Valves* — Hardened steel alloy. Valves rotate 3° each time they lift to seat in a new position and allow even heat distribution (except for 3116).

\*Except for MaK and CM engines.

**Gaseous Fueled Engines**

*Combustion System* — The piston design and compression ratios available provide the ability to utilize a wide variety of gaseous fuels as well as provide low emission output (below 2.0 grams/bhp-hr No<sub>x</sub>).

*Fuel System* — Heavy-duty, industrial-type carburetors designed to maintain optimum air-fuel ratio at all loads and speeds.

*Ignition System* — Cat Gaseous Fueled Engines employ a low tension magneto, together with an ignition transformer (one at each cylinder), to provide up to 34 kV to spark plugs. The Cat Electronic Ignition system is also available on certain engines.

**RATING EXPLANATIONS**

All engine ratings listed include such standard accessories as air cleaner and fuel, lube, and jacket water pumps. Power required for auxiliaries such as cooling fans, air compressors, charging alternators, special pumps, etc., must be deducted to arrive at the net power available to drive the load (except as noted). Other ratings are available for specific application and customer requirements, i.e., locomotive, oil field, fire pump, irrigation, etc. Consult your Cat dealer.

**Rating Conditions**

Performance is based on SAE J1995 standard conditions of 100 kPa (29.61 in Hg) and 25° C (77° F). Performance also applies at ISO 3046-1 (except for Spark Ignited Engines), DIN 6271 and BS 5514 standard conditions of 100 kPa (29.61 in Hg), 27° C (81° F) and 60% relative humidity.

Fuel consumption is based on fuel oil having an LHV of 42 780 kJ/kg (18,390 Btu/lb) and weighing 838.9 g/liter (7.001 lb/U.S. gal). All ratings are based on distillate fuel.

**Altitude and Temperature Capabilities**

*Industrial Diesel Engines* — Most intermittent and continuous ratings are applicable to at least 1320 m (5000 ft) elevation without derating. Consult factory for specific applications.

*Gaseous Fueled Engines* — Ratings for turbocharged and aftercooled engines are generally applicable to 1500 m (5000 ft). Naturally aspirated engines are applicable to 150 m (500 ft).

*Diesel Truck Engines* — Refer to specification sheets for altitude capability of individual truck engine ratings.

## Basic Specifications

Model	Displacement		Config.	Bore x Stroke		Fuel System	Power Range				
	L	in <sup>3</sup>		mm	in		Marine	Industrial	Elec. Power Gen.	Oil/ Gas	Rail Power
<b>C0.5</b>	0.5	<b>31</b>	I2	67x72	<b>2.6x2.8</b>	PC	See our listings for Marine Engines for complete information.	See our listings for Diesel Industrial for complete information.	See our listings for Generator Sets and Power Modules for complete information.	See our listings for Oil and Gas Engines for complete information.	See our listings for Railway Power for complete information.
<b>C0.7</b>	0.7	<b>46.4</b>	I3	67x72	<b>2.6x2.8</b>	PC					
<b>C1.1</b>	1.1	<b>69</b>	I3	77x81	<b>3.0x3.2</b>	PC					
<b>C1.5*</b>	1.5	<b>91</b>	I3	84x90	<b>3.3x3.5</b>	PC					
<b>C1.5</b>	1.5	<b>91</b>	I3	84x90	<b>3.3x3.5</b>	PC or Common Rail					
<b>C1.6</b>	1.5	<b>92</b>	I4	77x81	<b>3.0x3.2</b>	PC					
<b>C1.7</b>	1.66	<b>101</b>	I3	84x100	<b>3.3x3.9</b>	PC					
<b>C2.2*</b>	2.2	<b>135</b>	I4	84x100	<b>3.3x3.9</b>	PC					
<b>C2.2</b>	2.2	<b>135</b>	I4	84x100	<b>3.3x3.9</b>	Common Rail					
<b>C2.8</b>	2.8	<b>170.8</b>	I-4	90x110	<b>3.5x4.3</b>						
<b>C2.8*</b>	2.8	<b>170.8</b>	I-4	90x110	<b>3.5x4.3</b>						
<b>C3.4B</b>	3.4	<b>207.5</b>	I4	99x110	<b>3.9x4.3</b>	Common Rail					
<b>C3.6</b>	3.6	<b>219.6</b>	I-4	98x120	<b>3.9x4.7</b>						
<b>C3.6*</b>	3.6	<b>219.6</b>	I-4	98x120	<b>3.9x4.7</b>						
<b>3054C*</b>	4.4	<b>269</b>	I4	105x127	<b>4.1x5.0</b>						
<b>C4.4*</b>	4.4	<b>269</b>	I4	105x127	<b>4.1x5.0</b>	Common Rail					
<b>C4.4 ACERT™*</b>	4.4	<b>269</b>	I4	105x127	<b>4.1x5.0</b>	Common Rail					
<b>C4.4 ACERT</b>	4.4	<b>269</b>	I4	105x127	<b>4.1x5.0</b>	Common Rail					
<b>C6.6 ACERT*</b>	6.6	<b>402.8</b>	I6	105x127	<b>4.1x5.0</b>	Common Rail					
<b>C6.6 ACERT*</b>	6.6	<b>402.8</b>	I6	105x127	<b>4.1x5.0</b>	Common Rail					
<b>3056</b>	6	<b>365</b>	I6	100x127	<b>3.94x5.0</b>	MEUI™					
<b>C7</b>	7.24	<b>442</b>	I6	110x127	<b>4.33x5.0</b>	HEUI					
<b>C7 ACERT*</b>	7.2	<b>442</b>	I6	110x127	<b>4.33x5.0</b>	HEUI					
<b>C7.1*</b>	7	<b>427.7</b>	I6	105x135	<b>4.13x5.3</b>	Common Rail					
<b>C7.1 ACERT*</b>	7	<b>427.7</b>	I6	105x135	<b>4.13x5.3</b>	Common Rail					
<b>C7.1 ACERT</b>	7	<b>427.7</b>	I6	105x135	<b>4.13x5.3</b>	Common Rail					
<b>C9 ACERT*</b>	8.8	<b>537</b>	I6	112x149	<b>4.41x5.87</b>	Common Rail					
<b>C9.3 ACERT</b>	9.3	<b>567.5</b>	I6	115x149	<b>4.53x5.87</b>	Common Rail					
<b>C9.3B</b>	9.3	<b>567.5</b>	I-6	115x149	<b>4.53x5.87</b>	Common Rail					
<b>C11 ACERT*</b>	11.1	<b>677</b>	I6	130x140	<b>5.12x5.51</b>	MEUI					
<b>C11 ACERT</b>	11.1	<b>677</b>	I6	130x140	<b>5.12x5.51</b>	MEUI					
<b>C12</b>	12	<b>732</b>	I6	130x150	<b>5.1x5.9</b>	MEUI					
<b>C12 ACERT</b>	12	<b>732</b>	I6	130x150	<b>5.1x5.9</b>	MEUI					
<b>C13 ACERT*</b>	12.5	<b>763</b>	I6	130x157	<b>5.1x6.2</b>	MEUI					
<b>C13 ACERT</b>	12.5	<b>762.8</b>	I6	130x157	<b>5.1x6.2</b>	MEUI					

PC — Precombustion Chamber

MEUI — Mechanical Unit Injection

HEUI — Hydraulically Actuated Electronically Controlled

**NOTE:** Industrial models meet current U.S. EPA Tier 4 Final, EU Stage IIIA, IIIB, or IV emission standards, unless otherwise noted with an \*.

Models with an \* are available for other global regulated and non-regulated areas.

## Basic Specifications

Model	Displacement		Config.	Bore x Stroke		Fuel System	Power Range				
	L	in <sup>3</sup>		mm	in		Marine	Diesel Industrial	Elec. Power Gen.	Oil/Gas	Rail Power
<b>3406C*</b>	14.6	<b>893</b>	I6	137x165	<b>5.4x6.5</b>	MEUI	See our listings for Marine Engines for complete information.	See our listings for Diesel Industrial for complete information.	See our listings for Generator Sets and Power Modules for complete information.	See our listings for Oil and Gas Engines for complete information.	See our listings for Railway Power for complete information.
<b>C15 ACERT*</b>	15.2	<b>927.6</b>	I6	137.2x171.4	<b>5.4x6.75</b>						
<b>C15 ACERT C16</b>	15.2	<b>927.6</b>	I6	137x171	<b>5.4x6.73</b>						
<b>C16</b>	15.8	<b>964</b>	I6	140x171	<b>5.5x6.75</b>						
<b>C18 ACERT*</b>	18.1	<b>1104.5</b>	I6	145x183	<b>5.7x7.2</b>						
<b>C18 ACERT</b>	18.1	<b>1104.5</b>	I6	145x183	<b>5.7x7.2</b>						
<b>C18 ACERT</b>	18.1	<b>1106</b>	I6	145x183	<b>5.7x7.2</b>						
<b>C27 ACERT*</b>	27	<b>1648</b>	V12	137.2x152.4	<b>5.4x6.0</b>						
<b>C27 ACERT</b>	27	<b>1649.5</b>	V12	137.2x152.4	<b>5.4x6.0</b>						
<b>C32 ACERT*</b>	32.1	<b>1959</b>	V12	145x162	<b>5.7x6.4</b>						
<b>C32 ACERT</b>	32.1	<b>1959</b>	V12	145x162	<b>5.7x6.4</b>						
<b>3508*</b>	34.5	<b>2105</b>	V8	170x190	<b>6.7x7.5</b>						
<b>3508B*</b>	34.5	<b>2105</b>	V8	170x190	<b>6.7x7.5</b>						
<b>3508C</b>	34.5	<b>2107</b>	V8	170x190	<b>6.7x7.5</b>						
<b>3512*</b>	51.8	<b>3158</b>	V12	170x190	<b>6.7x7.5</b>						
<b>3512B*</b>	51.8	<b>3158</b>	V12	170x190	<b>6.7x7.5</b>						
<b>3512B HD</b>	58.6	<b>3576</b>	V12	170x215	<b>6.7x8.5</b>						
<b>3512C</b>	51.8	<b>3161</b>	V12	170x190	<b>6.69x7.48</b>						
<b>3512C HD</b>	58.6	<b>3574</b>	V12	170x215	<b>6.69x8.46</b>						
<b>3516*</b>	69	<b>4210</b>	V16	170x190	<b>6.7x7.5</b>						
<b>3516B*</b>	69	<b>4210</b>	V16	170x190	<b>6.7x7.5</b>						
<b>3516B HD</b>	78	<b>4766</b>	V16	170x215	<b>6.7x8.5</b>						
<b>3516C</b>	69	<b>4211</b>	V16	170x190	<b>6.69x7.48</b>						
<b>3516C HD</b>	78	<b>4765</b>	V16	170x215	<b>6.69x8.46</b>						
<b>C175-16</b>	84.67	<b>5167</b>	V16	175x220	<b>6.88x8.66</b>	Common Rail					
<b>C280-6</b>	111	<b>6773</b>	I6	280x300	<b>11.0x11.8</b>	MEUI					
<b>C280-8</b>	148	<b>9031</b>	I8	280x300	<b>11.0x11.8</b>	MEUI					
<b>C280-12</b>	222	<b>13,546</b>	V12	280x300	<b>11.0x11.8</b>	MEUI					
<b>C280-16</b>	296	<b>18,062</b>	V16	280x300	<b>11.0x11.8</b>	MEUI					

MEUI – Mechanical Unit Injection

**NOTE:** Industrial models meet current U.S. EPA Tier 4 Final, EU Stage IIIA, IIIB, or IV emission standards, unless otherwise noted with an \*. Models with an \* are available for other global regulated and non-regulated areas.

Basic Specifications – MaK Marine Propulsion Engines

MaK Model	Output Range		Speed	Mean Eff. Pressure	Mean Piston Speed	Bore	Stroke	Swept Volume	Dimensions						Weight
									Length	Width	Height 1 Dry/Wet Sump	Height 2	RCLTD*	RCLLD**	
	kW	mhp	rpm	bar	m/s	mm	mm	L	mm	mm	mm	mm	mm	mm	t
6 M 20 C	1020	1390	900	24.1	9.0	200	300	57	4049	1591	630/941	1714	1910	2085	10.9
	1080	1469	900	25.5	9.0	200	300	57	4049	1591	630/941	1714	1910	2085	10.9
	1140	1550	1000	24.2	10.0	200	300	57	4049	1591	630/941	1714	1910	2085	10.9
	1200	1632	1000	25.5	10.0	200	300	57	4049	1591	630/941	1714	1910	2085	10.9
8 M 20 C	1360	1850	900	24.1	9.0	200	300	75	4846	1727	630/941	1856	1910	2085	13.8
	1440	1958	900	25.5	9.0	200	300	75	4846	1727	630/941	1856	1910	2085	13.8
	1520	2070	1000	24.2	10.0	200	300	75	4846	1727	630/941	1856	1910	2085	13.8
	1600	2176	1000	25.5	10.0	200	300	75	4846	1727	630/941	1856	1910	2085	13.8
9 M 20 C	1530	2082	900	24.1	9.0	200	300	85	5176	1727	630/941	1856	1910	2085	15.0
	1620	2203	900	25.5	9.0	200	300	85	5176	1727	630/941	1856	1910	2085	15.0
	1710	2326	1000	24.2	10.0	200	300	85	5176	1727	630/941	1856	1910	2085	15.0
	1800	2448	1000	25.5	10.0	200	300	85	5176	1727	630/941	1856	1910	2085	15.0
6 M 25 C	1740	2370	720	23.7	9.6	255	400	123	5345	2237	861/1191	2526	2510	2735	23.5
	1800	2450	750	23.5	10.0	255	400	123	5345	2237	861/1191	2526	2510	2735	23.5
	2000	2720	720	27.2	9.6	255	400	123	5345	2237	861/1191	2526	2510	2735	23.5
	2000	2720	750	26.1	10.0	255	400	123	5345	2237	861/1191	2526	2510	2735	23.5
8 M 25 C	2320	3160	720	23.7	9.6	255	400	163	6289	2291	861/1191	2578	2510	2735	30.0
	2400	3260	750	23.5	10.0	255	400	163	6289	2291	861/1191	2578	2510	2735	30.0
	2666	3630	720	27.2	9.6	255	400	163	6289	2291	861/1191	2578	2510	2735	30.0
	2666	3630	750	26.1	10.0	255	400	163	6289	2291	861/1191	2578	2510	2735	30.0
9 M 25 C	2610	3550	720	23.7	9.6	255	400	184	6719	2291	861/1191	2578	2510	2735	32.0
	2700	3670	750	23.5	10.0	255	400	184	6719	2291	861/1191	2578	2510	2735	32.0
	3000	4080	720	27.2	9.6	255	400	184	6719	2291	861/1191	2578	2510	2735	32.0
	3000	4080	750	26.1	10.0	255	400	184	6719	2291	861/1191	2578	2510	2735	32.0
6 M 32 C	3000	4080	600	25.9	9.6	320	480	232	5936	2368	1052/1387	2784	3040	3405	39.5
8 M 32 C	4000	5440	600	25.9	9.6	320	480	309	7293	2128	1052/1387	2969	3040	3405	49.0
9 M 32 C	4500	6120	600	25.9	9.6	320	480	347	7823	2128	1052/1387	2969	3040	3405	52.0
6 M 25 E	2100	2856	720	28.5	9.6	255	400	123	4840	2080	861/1191	2525	2510	2735	23.5
	2100	2856	750	27.4	10.0	255	400	123	4840	2080	861/1191	2525	2510	2735	23.5
8 M 25 E	2800	3808	720	28.5	9.6	255	400	163	5700	2230	861/1191	2670	2510	2735	30.0
	2800	3808	750	27.4	10.0	255	400	163	5700	2230	861/1191	2670	2510	2735	30.0
9 M 25 E	3150	4284	720	28.5	9.6	255	400	184	6130	2230	861/1191	2670	2510	2735	32.0
	3150	4284	750	27.4	10.0	255	400	184	6130	2230	861/1191	2670	2510	2735	32.0
6 M 27 DF	1875	2550	720	21.9	9.6	275	400	143	5345	2261	861/1191	2526	2510	2735	23.5
	1875	2550	750	21.0	10.0	275	400	143	5345	2261	861/1191	2526	2510	2735	23.5
8 M 27 DF	2500	3400	720	21.9	9.6	275	400	190	6289	2316	861/1191	2578	2510	2735	30.0
	2500	3400	750	21.0	10.0	275	400	190	6289	2316	861/1191	2578	2510	2735	30.0
9 M 27 DF	2812	3825	720	21.9	9.6	275	400	214	6719	2316	861/1191	2578	2510	2735	32.0
	2812	3825	750	21.0	10.0	275	400	214	6719	2316	861/1191	2578	2510	2735	32.0

General definition of engine ratings: ISO 3046-1 – (IACS)  
 Meets IMO MARPOL Annex VI NO<sub>x</sub> requirements  
 Reference Conditions: Air Temperature: 25° C Air Pressure: 1 bar  
 Cooling water temperature at charge air cooler inlet: mean 30° C, max. 38° C

\*Removal of Cylinder Liner in Transverse Direction.  
 \*\*Removal of Cylinder Liner in Longitudinal Direction.

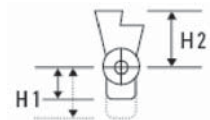

Dimensions of engine length for turbocharger at driving end, dimensions for turbocharger at free end on request.

## Basic Specifications – MaK Marine Propulsion Engines

MaK Model	Output Range		Speed	Mean Eff. Pressure	Mean Piston Speed	Bore	Stroke	Swept Volume	Dimensions						Weight
									Length	Width	Height 1 Dry/Wet Sump	Height 2	RCLTD*	RCLLD**	
	kW	mhp	rpm	bar	m/s	mm	mm	L	mm	mm	mm	mm	mm	mm	t
6 M 32 E	3300	4488	720	24.8	11.0	320	460	222	6055	2195	1052/1387	2810	3040	3400	37.5
	3300	4488	750	23.8	11.5	320	460	222	6055	2195	1052/1387	2810	3040	3400	37.5
8 M 32 E	4400	5984	720	24.8	11.0	320	460	296	7320	2195	1052/1387	3014	3040	3400	46.4
	4400	5984	750	23.8	11.5	320	460	296	7320	2195	1052/1387	3014	3040	3400	46.4
9 M 32 E	4950	6732	720	24.8	11.0	320	460	333	7850	2195	1052/1387	3014	3040	3400	49.4
	4950	6732	750	23.8	11.5	320	460	333	7850	2195	1052/1387	3014	3040	3400	49.4
12 M 32 C	6000	8160	720	22.5	11.0	320	460	444	6956	2985	1205/—	2319	2836	—	65.0
	6000	8160	750	21.6	11.5	320	460	444	6956	2985	1205/—	2319	2836	—	65.0
16 M 32 C	8000	10,880	720	22.5	11.0	320	460	592	8328	2985	1205/—	2319	2836	—	82.0
	8000	10,880	750	21.6	11.5	320	460	592	8328	2985	1205/—	2319	2836	—	82.0
12 M 32 E	6360	8650	720	23.9	11.0	320	460	444	6956	2985	1205/—	2319	2836	—	65.0
	6360	8650	750	22.9	11.5	320	460	444	6956	2985	1205/—	2319	2836	—	65.0
	6720	9139	720	25.2	11.0	320	460	444	6956	2985	1205/—	2319	2836	—	65.0
	6720	9139	750	24.2	11.5	320	460	444	6956	2985	1205/—	2319	2836	—	65.0
16 M 32 E	8480	11,533	720	23.9	11.0	320	460	592	8328	2985	1205/—	2319	2836	—	82.0
	8480	11,533	750	22.9	11.5	320	460	592	8328	2985	1205/—	2319	2836	—	82.0
	8960	12,186	720	25.2	11.0	320	460	592	8328	2985	1205/—	2319	2836	—	82.0
	8960	12,186	750	24.2	11.5	320	460	592	8328	2985	1205/—	2319	2836	—	82.0
6 M 34 DF	3060	4162	720	20.3	11.0	340	460	250	6109	2291	1052/1387	2817	3040	3400	39.5
	3180	4325	750	20.2	11.5	340	460	250	6109	2291	1052/1387	2817	3040	3400	39.5
8 M 34 DF	4080	5549	720	20.3	11.0	340	460	334	7325	2291	1052/1387	2995	3040	3400	49.0
	4240	5766	750	20.2	11.5	340	460	334	7325	2291	1052/1387	2995	3040	3400	49.0
9 M 34 DF	4590	6242	720	20.3	11.0	340	460	376	7855	2291	1052/1387	2995	3040	3400	52.0
	4770	6487	750	20.2	11.5	340	460	376	7855	2291	1052/1387	2995	3040	3400	52.0
6 M 43 C	6000	8160	500	27.1	10.2	430	610	531	8271	2878	1396/—	3734	4165	4610	94.0
	6000	8160	514	26.4	10.5	430	610	531	8271	2878	1396/—	3734	4165	4610	94.0
	6300	8568	500	28.4	10.2	430	610	531	8271	2878	1396/—	3734	4165	4610	94.0
	6300	8568	514	27.7	10.5	430	610	531	8271	2878	1396/—	3734	4165	4610	94.0
7 M 43 C	7000	9520	500	27.1	10.2	430	610	620	9068	2878	1396/—	4105	4165	4610	107.0
	7000	9520	514	26.4	10.5	430	610	620	9068	2878	1396/—	4105	4165	4610	107.0
	7350	9996	500	28.4	10.2	430	610	620	9068	2878	1396/—	4105	4165	4610	107.0
	7350	9996	514	27.7	10.5	430	610	620	9068	2878	1396/—	4105	4165	4610	107.0
8 M 43 C	8000	10,880	500	27.1	10.2	430	610	709	9798	2878	1396/—	4105	4165	4610	114.0
	8000	10,880	514	26.4	10.5	430	610	709	9798	2878	1396/—	4105	4165	4610	114.0
	8400	11,424	500	28.4	10.2	430	610	709	9798	2878	1396/—	4105	4165	4610	114.0
	8400	11,424	514	27.7	10.5	430	610	709	9798	2878	1396/—	4105	4165	4610	114.0

General definition of engine ratings: ISO 3046-1 — (IACS)

Meets IMO MARPOL Annex VI NO<sub>x</sub> requirements

Reference Conditions: Air Temperature: 25° C Air Pressure: 1 bar

Cooling water temperature at charge air cooler inlet: mean 30° C, max. 38° C

\*Removal of Cylinder Liner in Transverse Direction.

\*\*Removal of Cylinder Liner in Longitudinal Direction.

Dimensions of engine length for turbocharger at driving end, dimensions for turbocharger at free end on request.

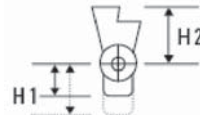

Basic Specifications – MaK Marine Propulsion Engines

MaK Model	Output Range		Speed	Mean Eff. Pressure	Mean Piston Speed	Bore	Stroke	Swept Volume	Dimensions						Weight
									Length	Width	Height 1 Dry/Wet Sump	Height 2	RCLTD*	RCLLD**	
	kW	mhp	rpm	bar	m/s	mm	mm	L	mm	mm	mm	mm	mm	mm	t
9 M 43 C	9000	12,240	500	27.1	10.2	430	610	797	10 528	2878	1396/—	4105	4165	4610	127.0
	9000	12,240	514	26.4	10.5	430	610	797	10 528	2878	1396/—	4105	4165	4610	127.0
	9450	12,852	500	28.4	10.2	430	610	797	10 528	2878	1396/—	4105	4165	4610	127.0
	9450	12,852	514	27.7	10.5	430	610	797	10 528	2878	1396/—	4105	4165	4610	127.0
12 M 43 C	12 000	16,320	500	27.1	10.2	430	610	1063	9842	3890	1625/—	3497	3700	—	160.0
	12 000	16,320	514	26.4	10.5	430	610	1063	9842	3890	1625/—	3497	3700	—	160.0
	12 600	17,136	500	28.4	10.2	430	610	1063	9842	3890	1625/—	3497	3700	—	160.0
	12 600	17,136	514	27.7	10.5	430	610	1063	9842	3890	1625/—	3497	3700	—	160.0
16 M 43 C	16 000	21,760	500	27.1	10.2	430	610	1417	11 943	4027	1625/—	3473	3700	—	220.0
	16 000	21,760	514	26.4	10.5	430	610	1417	11 943	4027	1625/—	3473	3700	—	220.0
	16 800	22,848	500	28.4	10.2	430	610	1417	11 943	4027	1625/—	3473	3700	—	220.0
	16 800	22,848	514	27.7	10.5	430	610	1417	11 943	4027	1625/—	3473	3700	—	220.0
6 M 46 DF	5400	7344	500	21.3	10.2	460	610	608	8330	2961	1396/—	3734	4165	4610	94.0
	5400	7344	514	20.7	10.5	460	610	608	8330	2961	1396/—	3734	4165	4610	94.0
	5790†	7874	500	22.8	10.2	460	610	608	8330	2961	1396/—	3734	4165	4610	94.0
	5790†	7874	514	22.2	10.5	460	610	608	8330	2961	1396/—	3734	4165	4610	94.0
7 M 46 DF	6300	8568	500	21.3	10.2	460	610	709	9068	2961	1396/—	4105	4165	4610	107.0
	6300	8568	514	20.7	10.5	460	610	709	9068	2961	1396/—	4105	4165	4610	107.0
	6755†	9187	500	22.8	10.2	460	610	709	9068	2961	1396/—	4105	4165	4610	107.0
	6755†	9187	514	22.2	10.5	460	610	709	9068	2961	1396/—	4105	4165	4610	107.0
8 M 46 DF	7200	9792	500	21.3	10.2	460	610	811	9798	2961	1396/—	4105	4165	4610	114.0
	7200	9792	514	20.7	10.5	460	610	811	9798	2961	1396/—	4105	4165	4610	114.0
	7720†	10,499	500	22.8	10.2	460	610	811	9798	2961	1396/—	4105	4165	4610	114.0
	7720†	10,499	514	22.2	10.5	460	610	811	9798	2961	1396/—	4105	4165	4610	114.0
9 M 46 DF	8100	11,016	500	21.3	10.2	460	610	912	10 768	2961	1396/—	4105	4165	4610	127.0
	8100	11,016	514	20.7	10.5	460	610	912	10 768	2961	1396/—	4105	4165	4610	127.0
	8685†	11,812	500	22.8	10.2	460	610	912	10 768	2961	1396/—	4105	4165	4610	127.0
	8685†	11,812	514	22.2	10.5	460	610	912	10 768	2961	1396/—	4105	4165	4610	127.0
12 M 46 DF	10 800	14,688	500	21.3	10.2	460	610	1216	9847	3890	1625/—	3497	3700	—	160.0
	10 800	14,688	514	20.7	10.5	460	610	1216	9847	3890	1625/—	3497	3700	—	160.0
	11 580†	15,749	500	22.8	10.2	460	610	1216	9847	3890	1625/—	3497	3700	—	160.0
	11 580†	15,749	514	22.2	10.5	460	610	1216	9847	3890	1625/—	3497	3700	—	160.0
16 M 46 DF	14 400	19,584	500	21.3	10.2	460	610	1621	11 943	4027	1625/—	3473	3700	—	220.0
	14 400	19,584	514	20.7	10.5	460	610	1621	11 943	4027	1625/—	3473	3700	—	220.0
	15 440†	20,998	500	22.8	10.2	460	610	1621	11 943	4027	1625/—	3473	3700	—	220.0
	15 440†	20,998	514	22.2	10.5	460	610	1621	11 943	4027	1625/—	3473	3700	—	220.0

General definition of engine ratings: ISO 3046-1 — (IACS)  
 Meets IMO MARPOL Annex VI NO<sub>x</sub> requirements  
 Reference Conditions: Air Temperature: 25° C Air Pressure: 1 bar  
 Cooling water temperature at charge air cooler inlet: mean 30° C, max. 38° C

\*Removal of Cylinder Liner in Transverse Direction.  
 \*\*Removal of Cylinder Liner in Longitudinal Direction.  
 †MDO only.

Dimensions of engine length for turbocharger at driving end, dimensions for turbocharger at free end on request.

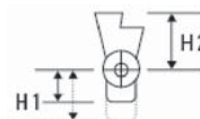

# Engines

## Rental Generator Sets

- Diesel Ratings
- Gas Ratings

### Rental Generator Sets\*

#### Diesel Ratings

50 Hz				
Model	rpm	Standby	Prime	Continuous
		kVA		
<b>3-Phase Output</b>				
XQE20	1500	—	20	—
XQE30	1500	—	30	—
XQE60	1500	—	60	—
XQE80	1500	—	80	—
XQE100	1500	—	100	—
XQP150	1500	—	150	—
XQP275	1500	—	275	—
XQP300	1500	—	300	—
XQP500	1500	—	500	—
XQC1200	1500	—	—	1438
XQC1600	1500	—	—	1893
XQ2000 DGB	1500	—	2000	1750

60 Hz				
Model	rpm	Standby	Prime	Continuous
		ekW		
XQ200**	1800	200	182	—
XQC1200	1800	—	—	1260
XQC1600	1800	—	—	1705

kVA				
Model	rpm	Standby	Prime	Continuous
XQ35	1800	38	34	—
XQ60	1800	—	60	—
XQ425	1800	469	425	—
XQ570	1800	625	568	—

\*Price list only products.

\*\*Subject to availability "Flex."

#### Gas Ratings

60 Hz				
Model	rpm	Standby	Prime	Continuous
		ekW		
<b>3-Phase Output</b>				
XG135	1800	—	—	135
XG400	1800	—	—	400

50/60 Hz				
Model	rpm	Standby	Prime	Continuous
		ekW		
XQ1475	1500/1800	—	—	1475

## Cat® Generator Sets

### Gas Ratings

60 Hz		
Model	Standby	Continuous
	ekW	
1800 rpm		
G3306	—	76
G3306	—	87
G3306	—	104
G3406	215	137
G3306	—	143
G3406	—	155
G3406	—	192
G3412	—	194
G3406	—	217
G3412C	375	253
CG132-8	—	400
G3412	—	403
G3412C	500	453
CG132-12	—	600
G3512	—	615
CG132-16	—	800
G3516	1000	—
G3516C	1500	—
G3516C	—	1663
G3520C	—	2077

60 Hz		
Model	Standby	Continuous
	ekW	
1500 rpm		
CG170-12	—	1200
CG170-16	—	1550
G3520C	—	1936
CG170-20	—	2000
G3516H	—	2005
G3520E	—	2026
G3520H	—	2500
1200 rpm		
G3516	—	779
G3516	—	824
G3516	—	1015
G3516B	—	1312
G3520C	—	1626
900 rpm		
CG260-12	—	3000
CG260-16	—	3370
CG260-16	—	4000
720 rpm		
G16CM34	—	6520
G20CM34	—	9700

#### Rating Definitions:

**Standby** — These ratings are applicable for supplying continuous electrical power (at variable load) in the event of a utility power failure. No overload is permitted on these ratings. Natural gas ratings have been established on natural gas with net calorific Low Heat Value (LHV) of approximately 36.2 mJ/m<sup>3</sup> (920 Btu/ft<sup>3</sup>).

**Continuous** — Output available without varying load for an unlimited time. Continuous power in accordance with ISO 8528, ISO 3046-1, AS2789, DIN6271, and BS5514. Natural gas ratings have been established on natural gas with net calorific Low Heat Value (LHV) of approximately 36.2 mJ/m<sup>3</sup> (920 Btu/ft<sup>3</sup>).



## Cat Generator Sets

## Gas Ratings

50 Hz	
Model	Continuous ekW
1500 rpm	
G3306	66
G3306	86
G3406	107
G3306	115
G3406	126
G3406	166
G3412	174
G3412	282
G3412C	374
G3412C	400
CG132-12	600
CG132-16	800
G3516	983
G3512E	1017
G3516	1041
G3516	1088
G3516	1105
CG170-12	1200
G3512E	1211
CG170-16	1560
G3516E	1603
G3516C	1605
G3520C	1982
CG170-20	2000
G3520C	2010
G3516H	2027
G3520H	2519

50 Hz	
Model	Continuous ekW
1000 rpm	
CG260-12	3333
G3616	3440
CG260-16	3770
CG260-16	4500
750 rpm	
G16CM34	6520
G20CM34	9700

**Rating Definitions:**

**Standby** — These ratings are applicable for supplying continuous electrical power (at variable load) in the event of a utility power failure. No overload is permitted on these ratings. Natural gas ratings have been established on natural gas with net calorific Low Heat Value (LHV) of approximately 36.2 mJ/m<sup>3</sup> (**920 Btu/ft<sup>3</sup>**).

**Continuous** — Output available without varying load for an unlimited time. Continuous power in accordance with ISO 8528, ISO 3046-1, AS2789, DIN6271, and BS5514. Natural gas ratings have been established on natural gas with net calorific Low Heat Value (LHV) of approximately 36.2 mJ/m<sup>3</sup> (**920 Btu/ft<sup>3</sup>**).

**MaK Marine Generator Sets**

**Medium Speed Ratings**

MaK Model	Output Range			Frequency	Speed	Bore	Stroke	Dimensions*			Weight*
								Single Length	Single Width	Single Height	
	kW	kWe	kVA	Hz	rpm	mm	mm	mm	mm	mm	t
<b>6 M 20 C</b>	1020	979	1224	60	900	200	300	6073	1680	2833	18.8
	1080	1036	1296	60	900	200	300	6073	1680	2833	18.8
	1140	1094	1368	50	1000	200	300	6073	1680	2833	18.8
	1200	1151	1440	50	1000	200	300	6073	1680	2833	18.8
<b>8 M 20 C</b>	1360	1306	1632	60	900	200	300	6798	1816	3010	23.1
	1440	1381	1728	60	900	200	300	6798	1816	3010	23.1
	1520	1459	1824	50	1000	200	300	6798	1816	3010	23.1
	1600	1534	1920	50	1000	200	300	6798	1816	3010	23.1
<b>9 M 20 C</b>	1530	1468	1836	60	900	200	300	7125	1816	3010	30.0
	1620	1553	1944	60	900	200	300	7125	1816	3010	30.0
	1710	1641	2052	50	1000	200	300	7125	1816	3010	30.0
	1800	1726	2160	50	1000	200	300	7125	1816	3010	30.0
<b>6 M 25 C</b>	1740	1669	2088	60	720	255	400	8070	2479	3911	43.0
	1800	1726	2160	50	750	255	400	8070	2479	3911	43.0
	2000	1918	2400	60	720	255	400	8070	2479	3911	43.0
	2000	1918	2400	50	750	255	400	8070	2479	3911	43.0
<b>8 M 25 C</b>	2320	2225	2784	60	720	255	400	9130	2534	3963	53.0
	2400	2302	2880	50	750	255	400	9130	2534	3963	53.0
	2666	2557	3199	60	720	255	400	9130	2534	3963	53.0
	2666	2557	3199	50	750	255	400	9130	2534	3963	53.0
<b>9 M 25 C</b>	2610	2503	3132	60	720	255	400	9516	2534	3963	56.0
	2700	2589	3240	50	750	255	400	9516	2534	3963	56.0
	3000	2877	3600	60	720	255	400	9516	2534	3963	56.0
	3000	2877	3600	50	750	255	400	9516	2534	3963	56.0
<b>6 M 32 C</b>	3000	2877	3600	50/60	600	320	480	9302	2639	4801	73.0
<b>8 M 32 C</b>	4000	3836	4800	50/60	600	320	480	10 886	2600	4869	92.0
<b>9 M 32 C</b>	4500	4316	5400	50/60	600	320	480	11 419	2600	4869	98.0
<b>6 M 25 E</b>	2100	2014	2520	60	720	255	400	7717	2357	4066	43.0
	2100	2014	2520	50	750	255	400	7717	2357	4066	43.0
<b>8 M 25 E</b>	2800	2685	3360	60	720	255	400	8283	2357	4066	53.0
	2800	2685	3360	50	750	255	400	8283	2357	4066	53.0
<b>9 M 25 E</b>	3150	3021	3780	60	720	255	400	8713	2357	4066	56.0
	3150	3021	3780	50	750	255	400	8713	2357	4066	56.0
<b>6 M 27 DF</b>	1875	1800	2250	60	720	275	400	8070	2479	3911	43.0
	1875	1800	2250	50	750	275	400	8070	2479	3911	43.0
<b>8 M 27 DF</b>	2500	2400	3000	60	720	275	400	9130	2534	3963	53.0
	2500	2400	3000	50	750	275	400	9130	2534	3963	53.0
<b>9 M 27 DF</b>	2812	2700	3375	60	720	275	400	9516	2534	3963	56.0
	2812	2700	3375	50	750	275	400	9516	2534	3963	56.0
<b>6 M 32 E</b>	3300	3165	3960	60	720	320	460	9566	2600	4567	71.0
	3300	3165	3960	50	750	320	460	9566	2600	4567	71.0
<b>8 M 32 E</b>	4400	4220	5280	60	720	320	460	10 625	2600	4770	89.4
	4400	4220	5280	50	750	320	460	10 625	2600	4770	89.4
<b>9 M 32 E</b>	4950	4747	5940	60	720	320	460	11 156	2600	4808	95.4
	4950	4747	5940	50	750	320	460	11 156	2600	4808	95.4

\*Weights and measures depend on generator make/type.

Generator efficiency: 0.96, cos φ 0.8

Specific lubricating oil consumption 0.6 g/kWh, ± 0.3 g/kWh

LCV = 42 700 kJ/kg, without engine-driven pumps, tolerance 5%

## MaK Marine Generator Sets

### Medium Speed Ratings

MaK Model	Output Range			Frequency	Speed	Bore	Stroke	Dimensions*			Weight*
								Single Length	Single Width	Single Height	
	kW	kWe	kVA	Hz	rpm	mm	mm	mm	mm	mm	t
12 M 32 C	6000	5754	7200	60	720	320	460	10 703	3526	4639	120.0
	6000	5754	7200	50	750	320	460	10 703	3526	4639	120.0
16 M 32 C	8000	7672	9600	60	720	320	460	12 149	3526	4639	140.0
	8000	7672	9600	50	750	320	460	12 149	3526	4639	140.0
12 M 32 E	6360	6099	7632	60	720	320	460	10 703	3526	4639	120.0
	6360	6099	7632	50	750	320	460	10 703	3526	4639	120.0
	6720	6444	8064	60	720	320	460	10 703	3526	4639	120.0
	6720	6444	8064	50	750	320	460	10 703	3526	4639	120.0
16 M 32 E	8480	8132	10 176	60	720	320	460	12 149	3526	4639	140.0
	8480	8132	10 176	50	750	320	460	12 149	3526	4639	140.0
	8960	8593	10 752	60	720	320	460	12 149	3526	4639	140.0
	8960	8593	10 752	50	750	320	460	12 149	3526	4639	140.0
6 M 34 DF	3060	2934	3672	60	720	340	460	9566	2600	4567	73.0
	3180	3050	3816	50	750	340	460	9566	2600	4567	73.0
8 M 34 DF	4080	3913	4896	60	720	340	460	10 625	2600	4770	92.0
	4240	4066	5088	50	750	340	460	10 625	2600	4770	92.0
9 M 34 DF	4590	4401	5508	60	720	340	460	11 156	2600	4770	98.0
	4770	4547	5724	50	750	340	460	11 156	2600	4770	98.0
6 M 43 C	5400	5179	6480	50/60	500/514	430	610	12 202	3400	6278	178.0
	6000	5754	7200	50/60	500/514	430	610	12 202	3400	6278	178.0
	6300	6042	7560	50/60	500/514	430	610	12 202	3400	6278	178.0
7 M 43 C	6300	6042	7560	50/60	500/514	430	610	12 999	3400	6649	195.0
	7000	6713	8400	50/60	500/514	430	610	12 999	3400	6649	195.0
	7350	7049	8820	50/60	500/514	430	610	12 999	3400	6649	195.0
8 M 43 C	7200	6905	8640	50/60	500/514	430	610	13 729	3400	6649	210.0
	8000	7672	9600	50/60	500/514	430	610	13 729	3400	6649	210.0
	8400	8056	10 080	50/60	500/514	430	610	13 729	3400	6649	210.0
9 M 43 C	8100	7768	9720	50/60	500/514	430	610	14 459	3400	6649	240.0
	9000	8631	10 800	50/60	500/514	430	610	14 459	3400	6649	240.0
	9450	9063	11 340	50/60	500/514	430	610	14 459	3400	6649	240.0
12 M 43 C	10 800	10 357	12 960	50/60	500/514	430	610	9482	3890	5122	160.0
	12 000	11 508	14 400	50/60	500/514	430	610	9482	3890	5122	160.0
	12 600	12 083	15 120	50/60	500/514	430	610	9482	3890	5122	160.0
16 M 43 C	14 400	13 810	17 280	50/60	500/514	430	610	11 943	4027	5098	220.0
	16 000	15 344	19 200	50/60	500/514	430	610	11 943	4027	5098	220.0
	16 800	16 111	20 160	50/60	500/514	430	610	11 943	4027	5098	220.0
	5400	5179	6480	50/60	500/514	460	610	12 202	3400	6278	178.0
6 M 46 DF	5790	5553	6948	50/60	500/514	460	610	12 202	3400	6278	178.0
	6300	6042	7560	50/60	500/514	460	610	12 999	3400	6649	195.0
7 M 46 DF	6755	6478	8106	50/60	500/514	460	610	12 999	3400	6649	195.0
	7200	6905	8640	50/60	500/514	460	610	13 729	3400	6649	210.0
8 M 46 DF	7720	7403	9264	50/60	500/514	460	610	13 729	3400	6649	210.0
	8100	7768	9720	50/60	500/514	460	610	14 459	3400	6649	240.0
9 M 46 DF	8685	8329	10 422	50/60	500/514	460	610	14 459	3400	6649	240.0
	10 800	10 357	12 960	50/60	500/514	460	610	9847	3890	5122	160.0
12 M 46 DF	11 580	11 105	13 896	50/60	500/514	460	610	9847	3890	5122	160.0
	14 400	13 810	17 280	50/60	500/514	460	610	11 943	4027	5098	220.0
	15 440	14 807	18 528	50/60	500/514	460	610	11 943	4027	5098	220.0

\*Weights and measures depend on generator make/type.

Generator efficiency: 0.96,  $\cos \varphi$  0.8

Specific lubricating oil consumption 0.6 g/kWh,  $\pm$  0.3 g/kWh

LCV = 42 700 kJ/kg, without engine-driven pumps, tolerance 5%

## Cat Generator Sets

### Diesel Ratings

60 Hz			
Model	rpm	Standby	Prime
		ekW	
<b>3-Phase Output*</b>			
D40	1800	40	36
D50	1800	50	45
D60	1800	60	55
D80	1800	80	72
D100	1800	100	90
D125	1800	125	114
D150	1800	150	136
D175	1800	175	158
D200	1800	200	—
<b>Single Phase Output**</b>			
D40S	1800	40	36
D50S	1800	50	45
D60S	1800	60	55
D80S	1800	80	72
D100S	1800	100	90

\*All ratings at 0.8 pf.  
\*\*All ratings at 1.0 pf.

60 Hz			
Model	Standby	Prime	Continuous
			ekW
<b>1800 rpm</b>			
C9	200	180	—
C9	250	225	—
C9	300	275	—
3406C	300	275	—
C15	350	320	—
C13	350	320	—
C13	400	350	—
C15	400	365	—
C15	450	410	—
C15	500	455	—
C18	550	500	—
C18	600	545	—
3412C	650	591	—
3412C	700	635	—
C27	750	680	—
3412C	750	680	—
C27	800	725	—
3412C	800	725	—
C32	1000	910	830
3512	1100	1000	890
3512	1250	1135	1010
3512B	1400	1275	—
3512B	1500	1360	1230
3512C	1500	1360	1230
3516	1750	1600	1450
3516B	2000	1825	1640
3516C	2000	1825	1650
3516B	2250	—	—
3516C-HD	2500	2250	2050
C175-16	3000	2725	2500
C175-16	3100	2825	2600
C175-20	4000	3600	3250

#### Rating Definitions:

**Standby Power Rating** — Output available with varying load for the duration of the interruption of the normal source power. Average power output is 70% of the standby power rating. Typical operation is 200 hours per year, with maximum expected usage of 500 hours per year.

**Prime Power Rating** — Output available with varying load for an unlimited time. Average power output is 70% of the prime power rating. Typical peak demand is 100% of prime rated kW with 10% overload capability for emergency use for a maximum of 1 hour in 12. Overload operation cannot exceed 25 hours per year.

**Continuous Power Rating** — Output available with non-varying load for an unlimited time. Average power output is 70-100% of the continuous power rating. Typical peak demand is 100% of continuous rated kW for 100% of operating hours.

**Applicable Codes and Standards:** AS1359, CSAC22.2 No100-04, UL142, UL489, UL869, UL2200, NFPA37, NFPA70, NFPA99, NFPA110, IBC, IEC60034-1, ISO 3046, ISO 8528, NEMA MG 1-22, NEMA MG 1-33, 2006/95/EC for Low Voltage, 2006/42/EC for Machinery, 2004/108/EC.

**Fuel rates** are based on fuel oil of 35° API [16° C (60° F)] gravity having an LHV of 42 780 kJ/kg (18,390 Btu/lb) when used at 29° C (85° F) and weighing 838.9 g/liter (7,001 lb/U.S. gal). Additional ratings may be available for specific customer requirements, contact your Caterpillar representative for details. For information regarding Low Sulfur fuel and Biodiesel capability, please consult your Cat dealer.

## Cat Generator Sets

## Diesel Ratings

60 Hz			
Model	Standby	Prime	Continuous
ekW			
900 rpm			
6CM20C	1037	979	979
8CM20C	1382	1306	1306
9CM20C	1555	1469	1469
3606	2000	1820	1650
3608	2660	2420	2200
3612	4000	3640	3300
3616	5320	4840	4400
720 rpm			
3606	1680	1525	1375
6CM25C	1920	1728	1728
3608	2200	2020	1830
8CM25C	2559	2304	2304
9CM25C	2880	2592	2592
3612	3360	3050	2750
3616	4400	4040	3660
12CM32C	6169	5820	5820
16CM32C	8226	7760	7760
600 rpm			
6CM32C	2880	2765	2765
8CM32C	3840	3686	3686
9CM32C	4320	4147	4147
514 rpm			
6CM43C	6111	5471	5471
7CM43C	7130	6383	6383
8CM43C	8148	7294	7294
9CM43C	9167	8206	8206
12CM43C	12 222	10 942	10 942
16CM43C	16 296	14 589	14 589

NOTE: All CM engines for land based application rated in accordance with WBII.

## Rating Definitions:

**Standby Power Rating** — Output available with varying load for the duration of the interruption of the normal source power. Average power output is 70% of the standby power rating. Typical operation is 200 hours per year, with maximum expected usage of 500 hours per year.

**Prime Power Rating** — Output available with varying load for an unlimited time. Average power output is 70% of the prime power rating. Typical peak demand is 100% of prime rated kW with 10% overload capability for emergency use for a maximum of 1 hour in 12. Overload operation cannot exceed 25 hours per year.

**Continuous Power Rating** — Output available with non-varying load for an unlimited time. Average power output is 70-100% of the continuous power rating. Typical peak demand is 100% of continuous rated kW for 100% of operating hours.

**Applicable Codes and Standards:** AS1359, CSAC22.2 No100-04, UL142, UL489, UL869, UL2200, NFPA37, NFPA70, NFPA99, NFPA110, IBC, IEC60034-1, ISO 3046, ISO 8528, NEMA MG 1-22, NEMA MG 1-33, 2006/95/EC for Low Voltage, 2006/42/EC for Machinery, 2004/108/EC.

**Fuel rates** are based on fuel oil of 35° API [16° C (60° F)] gravity having an LHV of 42 780 kJ/kg (18,390 Btu/lb) when used at 29° C (85° F) and weighing 838.9 g/liter (7.001 lb/U.S. gal). Additional ratings may be available for specific customer requirements, contact your Caterpillar representative for details. For information regarding Low Sulfur fuel and Biodiesel capability, please consult your Cat dealer.

## Cat Generator Sets

### Diesel Ratings

50 Hz			
Model	rpm	Standby	Prime
		kVA	
<b>3-Phase Output*</b>			
DE9.5E3	1500	9.5	8.5
DE13.5E3	1500	13.5	12.5
DE18E3	1500	18	16.5
DE22E3	1500	22	20
DE33E0	1500	33	30
DE33E3	1500	33	30
DE50E0	1500	50	45
DE55E2	1500	55	50
DE65E0	1500	65	60
DE65E3	1500	65	60
DE88E0	1500	88	80
DE88E3	1500	88	80
DE110E2	1500	110	100
DE110E3	1500	110	100
DE165E0	1500	165	150
DE200E0	1500	200	180
DE220E0	1500	218	200
<b>Single Phase Output**</b>			
DE7.5E3S	1500	7.5	6.8
DE11E3S	1500	11	10
DE14E3S	1500	14	13
DE16E3S	1500	16.5	15
DE26E0S	1500	26	24
DE26E3S	1500	26	24
DE40E0S	1500	40	36
DE40E2S	1500	40	36
DE50E0S	1500	50	45
DE55E3S	1500	55	50
DE90E2S	1500	90	82
DE90E3S	1500	90	82

\*All ratings at 0.8 pf.

\*\*All ratings at 1.0 pf.

50 Hz			
Model	rpm	Standby	Prime
		kVA	
<b>1500 rpm</b>			
3406C	300	275	—
3406C	350	320	—
C13	400	350	—
C13	450	400	—
C15 ACERT	500	455	—
C15 ACERT	550	500	—
C18 ACERT	605	550	—
C18 ACERT	660	600	—
C18 ACERT	700	635	—
3412C	750	680	—
3412C	800	725	—
3412C	900	810	—
C32 ACERT	1100	1000	910
C32 ACERT	1250	1150	—
3512	1250	1150	1000
3512	1400	1275	1206
3512B	1500	1360	—
3512B	1600	1500	1320
3512B-HD	1750	1600	—
3512B-HD	1875	1700	1500
3516	2000	1825	1600
3516B	2250	2000	1750
3516B-HD	2500	2275	2000
3516C	2750	2500	—
C175-16	3000	2725	2500
C175-16	3100*	2825*	2600*
C175-20	4000	3600	3250

\*Rating does not include package mounted radiator.

#### Rating Definitions:

**Standby Power Rating** — Output available with varying load for the duration of the interruption of the normal source power. Average power output is 70% of the standby power rating. Typical operation is 200 hours per year, with maximum expected usage of 500 hours per year.

**Prime Power Rating** — Output available with varying load for an unlimited time. Average power output is 70% of the prime power rating. Typical peak demand is 100% of prime rated kW with 10% overload capability for emergency use for a maximum of 1 hour in 12. Overload operation cannot exceed 25 hours per year.

**Continuous Power Rating** — Output available with non-varying load for an unlimited time. Average power output is 70-100% of the continuous power rating. Typical peak demand is 100% of continuous rated kW for 100% of operating hours.

**Applicable Codes and Standards:** AS1359, CSACC2.2 No100-04, UL142, UL489, UL869, UL2200, NFPA37, NFPA70, NFPA99, NFPA110, IBC, IEC60034-1, ISO 3046, ISO 8528, NEMA MG 1-22, NEMA MG 1-33, 2006/95/EC for Low Voltage, 2006/42/EC for Machinery, 2004/108/EC.

**Fuel rates** are based on fuel oil of 35° API [16° C (60° F)] gravity having an LHV of 42 780 kJ/kg (18,390 Btu/lb) when used at 29° C (85° F) and weighing 838.9 g/liter (7.001 lb/U.S. gal). Additional ratings may be available for specific customer requirements, contact your Caterpillar representative for details. For information regarding Low Sulfur fuel and Biodiesel capability, please consult your Cat dealer.

## Cat Generator Sets

## Diesel Ratings

50 Hz			
Model	Standby	Prime	Continuous
kVA			
1000 rpm			
6CM20C	1440	1368	1368
8CM20C	1920	1824	1824
9CM20C	2160	2052	2052
3606	2688	2425	2200
3608	3575	3250	2938
3612	5375	4850	4400
3616	7150	6500	5875
750 rpm			
3606	2163	1963	1775
6CM25C	2400	2160	2160
3608	2863	2600	2363
8CM25C	3199	2880	2880
9CM25C	3600	3240	3240
3612	4325	3925	3550
3616	5725	5200	4725
12CM32C	7712	7275	7275
16CM32C	10 282	9700	9700
600 rpm			
6CM32C	3600	3456	3456
8CM32C	4800	4608	4608
9CM32C	5400	5184	5184
500 rpm			
6CM43C	7639	6839	6839
7CM43C	8912	7978	7978
8CM43C	10 185	9118	9118
9CM43C	11 458	10 258	10 258
12CM43C	15 278	13 677	13 677
16CM43C	20 370	18 236	18 236

NOTE: All CM engines for land based application rated in accordance with WBII.

## Rating Definitions:

**Standby Power Rating** — Output available with varying load for the duration of the interruption of the normal source power. Average power output is 70% of the standby power rating. Typical operation is 200 hours per year, with maximum expected usage of 500 hours per year.

**Prime Power Rating** — Output available with varying load for an unlimited time. Average power output is 70% of the prime power rating. Typical peak demand is 100% of prime rated kW with 10% overload capability for emergency use for a maximum of 1 hour in 12. Overload operation cannot exceed 25 hours per year.

**Continuous Power Rating** — Output available with non-varying load for an unlimited time. Average power output is 70-100% of the continuous power rating. Typical peak demand is 100% of continuous rated kW for 100% of operating hours.

**Applicable Codes and Standards:** AS1359, CSAC22.2 No100-04, UL142, UL489, UL869, UL2200, NFPA37, NFPA70, NFPA99, NFPA110, IBC, IEC60034-1, ISO 3046, ISO 8528, NEMA MG 1-22, NEMA MG 1-33, 2006/95/EC for Low Voltage, 2006/42/EC for Machinery, 2004/108/EC.

**Fuel rates** are based on fuel oil of 35° API [16° C (60° F)] gravity having an LHV of 42 780 kJ/kg (18,390 Btu/lb) when used at 29° C (85° F) and weighing 838.9 g/liter (7.001 lb/U.S. gal). Additional ratings may be available for specific customer requirements, contact your Caterpillar representative for details. For information regarding Low Sulfur fuel and Biodiesel capability, please consult your Cat dealer.

Propulsion	Basic Information					Power Range		
	Displacement		Config.	Bore x Stroke		Rating	kW	bhp
	L	in <sup>3</sup>		mm	in			
C8.7	8.7	531	6	117 x 135	4.6 x 5.3	Recreational U.S. EPA Tier 3/IMO II Commercial IMO II/EU Stage IIIA		
						E	478	641
C9.3	9.3	568	6	115 x 149	4.53 x 5.87	U.S. EPA Tier 3 and IMO Tier II		
						B	280	376
						C	310	416
						D	355	476
C12	12	732	6	130 x 150	5.1 x 5.9	IMO Tier II		
						A	254	340
						B	287	385
						C	339-366	454-490
						D	425	570
						E	448	600
C12 ACERT	12	732	6	130 x 150	5.1 x 5.9	IMO Tier II		
						E	492-526	660-705
C12.9	12.9	787	6	135 x 150	5.31 x 5.9	Recreational U.S. EPA Tier 3/IMO II Commercial IMO II/EU Stage IIIA		
						E	625-735	838-985
3406C	14.6	891	6	137.2 x 165.1	5.4 x 6.5	IMO Tier II		
						A	272	365
						B	298	400
C18 ACERT	18.1	1106	6	145 x 183	5.7 x 7.2	IMO Tier II		
						A	339-447	454-600
						B	412-500	553-670
						C	533	715
						D	651	873
						U.S. EPA Tier 3 and IMO Tier II		
						A	350-447	469-600
						B	500	670
						C	533	715
						D	599	803
E	747-847	1001-1136						
C32 ACERT	32.1	1959	V12	145 x 162	5.71 x 6.38	IMO Tier II		
						A	492-746	660-1000
						B	895-970	1200-1300
						C	970-1081	1300-1450
						D	1193	1600
						U.S. EPA Tier 3 and IMO Tier II		
						A	559-746	750-1000
						B	895	1200
						C	970-1081	1300-1450
						D	1193	1600
E	1268-1417	1700-1900						

**For more information on IMO regulations and compliance contact:**

- For IMO and U.S. EPA requirements see [www3.epa.gov/otaq/marine.htm](http://www3.epa.gov/otaq/marine.htm)
- For IMO and Canada compliance see regulation 108 at [laws-lois.justice.gc.ca/eng/regulations/SOR-2012-69/index.html](http://laws-lois.justice.gc.ca/eng/regulations/SOR-2012-69/index.html)
- ABS guide "Notes on Prevention of Air Pollution from Ships," or call ABS, Texas, phone: (281) 877-6306

For information on Cat Marine engines, please visit us at [www.cat.com/marine](http://www.cat.com/marine) or contact your local dealer.



Propulsion	Basic Information					Power Range		
	Displacement		Config.	Bore x Stroke		Rating	b kW	bhp
	L	in <sup>3</sup>		mm	in			
<b>3508C</b>	34.5	<b>2107</b>	V8	170 x 190	<b>6.7 x 7.5</b>	IMO Tier II		
						A	578-746	<b>775-1000</b>
						B	634-783	<b>850-1050</b>
						C	671-820	<b>900-1100</b>
<b>3512C</b>	51.8	<b>3161</b>	V12	170 x 190	<b>6.69 x 7.48</b>	IMO Tier II		
	58.6	<b>3574</b>	V12	170 x 215	<b>6.69 x 8.46</b>	A	955-1350	<b>1280-1810</b>
						B	1014-1678	<b>1359-2250</b>
						C	1051-1765	<b>1409-2365</b>
						D	1902	<b>2551</b>
						U.S. EPA Tier 3 and IMO Tier II		
						A	1000-1350	<b>1340-1810</b>
						B	1175-1678	<b>1575-2249</b>
						C	1230-1765	<b>1649-2366</b>
						U.S. EPA Tier 4 Final and IMO Tier III (Preliminary)		
						A	1000-1678	<b>1341-2250</b>
						B	1175-1771	<b>1576-2375</b>
						C	1230-1901	<b>1650-2549</b>
<b>3516C</b>	69	<b>4211</b>	V16	170 x 190	<b>6.69 x 7.48</b>	IMO Tier II		
	78	<b>4765</b>	V16	170 x 215	<b>6.69 x 8.46</b>	A	1230-1825	<b>1650-2448</b>
						B	1305-2240	<b>1750-3004</b>
						C	1379-2350	<b>1850-3151</b>
						D	2100-2525	<b>2816-3386</b>
						U.S. EPA Tier 3 and IMO Tier II		
						A	1590-1825	<b>2131-2446</b>
						B	1670-1920	<b>2239-2574</b>
						C	1750-1995	<b>2346-2675</b>
<b>3516E</b>	78	<b>4765</b>	V16	170 x 215	<b>6.69 x 8.46</b>	U.S. EPA Tier 4 Final and IMO Tier III (Preliminary)		
						A	1865-2240	<b>2501-3004</b>
						B	2100-2350	<b>2816-3151</b>
						C	2200-2525	<b>2950-3386</b>
<b>C175-16</b>	84.57	<b>5167</b>	V16	175 x 220	<b>6.88 x 8.66</b>	IMO Tier II		
						A	2001-2428	<b>2683-3256</b>
						B	2168-2550	<b>2907-3420</b>
<b>C280-6</b>	111	<b>6773</b>	6	280 x 300	<b>11.0 x 11.8</b>	IMO Tier II		
						CS	1730-1850	<b>2320-2481</b>
						MC	1900-2030	<b>2548-2722</b>
<b>C280-8</b>	148	<b>9031</b>	8	280 x 300	<b>11.0 x 11.8</b>	IMO Tier II		
						CS	2300-2460	<b>3084-3299</b>
						MC	2530-2710	<b>3393-3634</b>
<b>C280-12</b>	222	<b>13,546</b>	12	280 x 300	<b>11.0 x 11.8</b>	IMO Tier II		
						CS	3460-3700	<b>4640-4962</b>
						MC	3800-4060	<b>5096-5444</b>

**For more information on IMO regulations and compliance contact:**

- For IMO and U.S. EPA requirements see [www3.epa.gov/otaq/marine.htm](http://www3.epa.gov/otaq/marine.htm)
- For IMO and Canada compliance see regulation 108 at [laws-lois.justice.gc.ca/eng/regulations/SOR-2012-69/index.html](http://laws-lois.justice.gc.ca/eng/regulations/SOR-2012-69/index.html)
- ABS guide "Notes on Prevention of Air Pollution from Ships," or call ABS, Texas, phone: (281) 877-6306

For information on Cat Marine engines, please visit us at [www.cat.com/marine](http://www.cat.com/marine) or contact your local dealer.

Generator Sets Model	Basic Information					Power Range		
	Displacement		Config.	Bore x Stroke		Frequency	Speed	Output
	L	in <sup>3</sup>		mm	in	Hz	rpm	ekW
C1.5	1.5	91	3	84 x 90	3.31 x 3.5	U.S. EPA Tier 3 and NST		
						60	1800	12.0-13.0
C2.2	2.2	135	4	84 x 100	3.31 x 3.94	U.S. EPA Tier 3 and NST		
						50	1500	10.0-11.0
C4.4	4.4	269	4	105 x 127	4.13 x 5.0	NST, CC2 (50 Hz)		
						60	1800	19.0-19.5
C4.4 ACERT	4.4	269	4	105 x 127	4.13 x 5.0	NST, CC2 (50 Hz)		
						50	1500	16.0-22.5
C4.4 ACERT	4.4	269	4	105 x 127	4.13 x 5.0	U.S. EPA Tier 3 and NST and CC2		
						60	1800	42.0-99.0
C7.1 ACERT	7.01	433.3	6	105 x 135	4.13 x 5.3	U.S. EPA Tier 3 and NST and IMO Tier II and CC2		
						50	1500	36.0-86.0
C9.3	9.3	568	6	105 x 135	4.13 x 5.31	U.S. EPA Tier 3 and IMO Tier II and CC2		
						60	1800	51-118
C18	18.1	1106	6	145 x 183	5.7 x 7.2	IMO Tier II and EU IW		
						50	1500	124-300
C32 ACERT	32.1	1959	V12	145 x 162	5.7 x 6.4	U.S. EPA Tier 3 and IMO Tier II and EU IW		
						60	1800	185-250
C280-6	111	6773	6	280 x 300	11.0 x 11.8	IMO Tier II		
						60	1800	345-395
C280-8	148	9031	8	280 x 300	11.0 x 11.8	IMO Tier II		
						50	1500	280-445
C280-12	222	13,546	V12	280 x 300	11.0 x 11.8	U.S. EPA Tier 3 and IMO Tier II		
						60	1800	430-530
C280-16	296	18,062	V16	280 x 300	11.0 x 11.8	IMO Tier II		
						60	1800	730-940
C280-6	111	6773	6	280 x 300	11.0 x 11.8	IMO Tier II		
						50	1500	550-830
C280-8	148	9031	8	280 x 300	11.0 x 11.8	U.S. EPA Tier 3 and IMO Tier II		
						60	1800	730-940
C280-12	222	13,546	V12	280 x 300	11.0 x 11.8	IMO Tier II		
						60	900	1650-1820
C280-16	296	18,062	V16	280 x 300	11.0 x 11.8	IMO Tier II		
						50	1000	1760-1940
C280-6	111	6773	6	280 x 300	11.0 x 11.8	IMO Tier II		
						60	900	2200-2420
C280-8	148	9031	8	280 x 300	11.0 x 11.8	IMO Tier II		
						50	1000	2350-2600
C280-12	222	13,546	V12	280 x 300	11.0 x 11.8	IMO Tier II		
						60	900	3300-3640
C280-16	296	18,062	V16	280 x 300	11.0 x 11.8	IMO Tier II		
						50	1000	3520-3880
C280-6	111	6773	6	280 x 300	11.0 x 11.8	IMO Tier II		
						60	900	4400-4840
C280-8	148	9031	8	280 x 300	11.0 x 11.8	IMO Tier II		
						50	1000	4700-5200

**For more information on IMO regulations and compliance contact:**

- For IMO and U.S. EPA requirements see [www3.epa.gov/otaq/marine.htm](http://www3.epa.gov/otaq/marine.htm)
- For IMO and Canada compliance see regulation 108 at [laws-lois.justice.gc.ca/eng/regulations/SOR-2012-69/index.html](http://laws-lois.justice.gc.ca/eng/regulations/SOR-2012-69/index.html)
- ABS guide "Notes on Prevention of Air Pollution from Ships," or call ABS, Texas, phone: (281) 877-6306

For information on Cat Marine engines, please visit us at [www.cat.com/marine](http://www.cat.com/marine) or contact your local dealer.

Auxiliary	Basic Information					Power Range		
	Displacement		Config.	Bore x Stroke		Speed	Output	
Model	L	in <sup>3</sup>		mm	in	rpm	bkW	
C9.3 GenSet/Aux Variable Speed	9.3	568	6	115 x 149	4.53 x 5.87	U.S. EPA Tier 3 and IMO Tier II and CC2		
						1800	275-325	
C15 Variable Speed/Aux	15.2	928	6	137 x 171	5.4 x 6.7	U.S. EPA Tier 3 and IMO Tier II		
						1800-2000	400-403	
C18 GenSet/Aux	18.1	1106	6	145 x 183	5.7 x 7.2	IMO Tier II and EU IW		
						1800	372-465	
						1500	301-492	
						U.S. EPA Tier 3 and IMO Tier II and EU IW		
C32 GenSet/Aux	32.1	1959	V12	145 x 162	5.7 x 6.4	IMO Tier II		
						1800	683-994	
						1500	590-874	
						U.S. EPA Tier 3 and IMO Tier II		
3500 Series Aux/DEP						IMO Tier II		
						1800	1432-2350	
						1500	1257-1940	
						U.S. EPA Tier 4 Final and IMO Tier III		
3500 E Series GenSet/Aux Preliminary	34.5	2107	V12	170 x 190	6.7 x 7.5	U.S. EPA Tier 4 Final and IMO Tier III		
	51.8	3161	V12	170 x 190	6.7 x 7.5	1800	1632-2368	
C280 Series Aux		111	6773	6	280 x 300	11.0 x 11.8	IMO Tier II	
		148	9031	8	280 x 300	11.0 x 11.8	900	1730-5060
		222	13,546	12	280 x 300	11.0 x 11.8	1000	1850-5420
		296	18,062	16	280 x 300	11.0 x 11.8		

**For more information on IMO regulations and compliance contact:**

- For IMO and U.S. EPA requirements see [www3.epa.gov/otaq/marine.htm](http://www3.epa.gov/otaq/marine.htm)
- For IMO and Canada compliance see regulation 108 at [laws-lois.justice.gc.ca/eng/regulations/SOR-2012-69/index.html](http://laws-lois.justice.gc.ca/eng/regulations/SOR-2012-69/index.html)
- ABS guide "Notes on Prevention of Air Pollution from Ships," or call ABS, Texas, phone: (281) 877-6306

For information on Cat Marine engines, please visit us at [www.cat.com/marine](http://www.cat.com/marine) or contact your local dealer.

**Cat Industrial Diesel Applications**

Meets U.S. EPA Tier 4 Final, EU Stage IIIB or Stage IV emission standards

Model	Type	"IND A"			"IND B"			"IND C"			"IND D"			"IND E"		
		bkW	bhp	rpm	bkW	bhp	rpm	bkW	bhp	rpm	bkW	bhp	rpm	bkW	bhp	rpm
C0.5	NA	—	—	—	—	—	—	8.2	11.0	2800*	—	—	—	—	—	—
		—	—	—	—	—	—	8.8	11.8	3000*	—	—	—	—	—	—
		—	—	—	—	—	—	10.2	13.7	3600*	—	—	—	—	—	—
C0.7	NA	—	—	—	—	—	—	12.2	16.4	2800*	—	—	—	—	—	—
		—	—	—	—	—	—	13.2	17.7	3000*	—	—	—	—	—	—
		—	—	—	—	—	—	15.3	20.5	3600*	—	—	—	—	—	—
C1.1	NA	—	—	—	—	—	—	13.7	18.4	2200*	—	—	—	—	—	—
		—	—	—	—	—	—	14.7	19.7	2200*	—	—	—	—	—	—
		—	—	—	—	—	—	16.1	21.6	2400*	—	—	—	—	—	—
		—	—	—	—	—	—	16.8	22.5	2800*	—	—	—	—	—	—
		—	—	—	—	—	—	17.2	23.0	2600*	—	—	—	—	—	—
		—	—	—	—	—	—	17.7	23.7	3000*	—	—	—	—	—	—
		—	—	—	—	—	—	18.4	24.7	2800	—	—	—	—	—	—
		—	—	—	—	—	—	19.7	26.4	3000*	—	—	—	—	—	—
C1.5	NA	—	—	—	—	—	—	21.0	28.2	3400*	—	—	—	—	—	—
		—	—	—	—	—	—	18.4	24.7	2100	—	—	—	—	—	—
		—	—	—	—	—	—	20.7	27.8	2200*	—	—	—	—	—	—
		—	—	—	—	—	—	23.4	31.4	2600*	—	—	—	—	—	—
C1.5	T	—	—	—	—	—	—	24.4	32.7	2800*	—	—	—	—	—	—
		—	—	—	—	—	—	25.1	33.7	3000*	—	—	—	—	—	—
		—	—	—	—	—	—	23.1	31.0	2200*	—	—	—	—	—	—
		—	—	—	—	—	—	25.2	33.8	2400	—	—	—	—	—	—
		—	—	—	—	—	—	27.0	36.2	2800	—	—	—	—	—	—
C1.5	T	—	—	—	—	—	—	27.3	36.6	2600*	—	—	—	—	—	—
		—	—	—	—	—	—	27.6	37.0	3000	—	—	—	—	—	—
		—	—	—	—	—	—	29.4	39.4	2800*	—	—	—	—	—	—
		—	—	—	—	—	—	30.0	40.2	3000*	—	—	—	—	—	—
		—	—	—	—	—	—	30.0	40.2	3000*	—	—	—	—	—	—

**Rating Conditions:**

**Diesel Engines — up to 7.1 liter**

All rating conditions are based on ISO/TR14396, inlet air standard conditions with a total barometric pressure of 100 kPa (29.5 in Hg), with a vapor pressure of 1 kPa (0.295 in Hg), and 25° C (77° F). Performance measured using fuel to EPA specifications in 40 CFR Part 1065 and EU specifications in Directive 97/68/EC with a density of 0.845-0.850 kg/L @ 15° C (59° F) and fuel inlet temperature 40° C (104° F).

**Diesel Engines — greater than 7.1 liter**

All rating conditions are based on SAE J1995, inlet air standard conditions of 99 kPa (29.31 in Hg) dry barometer and 25° C (77° F) temperature. Performance measured using a standard fuel with fuel gravity of 35° API having a lower heating value of 42 780 kJ/kg (18,390 btu/lb) when used at 29° C (84.2° F) with a density of 838.9 g/L

**Diesel Engine Rating Definitions**

**Explanation of Ratings A, B, C, D, and E:**

- For an exact determination of the appropriate rating, contact your local Cat dealer. Engine rating obtained and presented in accordance with ISO 3046/1.

**IND-A (Continuous)**

- Continuous heavy-duty service where the engine is operated at maximum power and speed up to 100% of the time without interruption or load cycling.

**IND-B**

- For service where power and/or speed are cyclic (time at full load not to exceed 80%).

**IND-C (Intermittent)**

- Intermittent service where maximum power and/or speed are cyclic (time at full load not to exceed 50%).

**IND-D**

- For service where maximum power is required for periodic overloads (time at full load not to exceed 10% of the duty cycle).

**IND-E**

- For service where maximum power is required for a short time for initial starting or sudden overload. For emergency service where standard power is unavailable (time at full load not to exceed 5% of the duty cycle).

NA — Naturally Aspirated  
bhp — Brake horsepower  
bkW — Brake kilowatts

\*Denotes rating is available in EU and other global regulated and non-regulated areas (Non-U.S.).

## Cat Industrial Diesel Applications

Meets U.S. EPA Tier 4 Final, EU Stage IIIB or Stage IV emission standards

Model Type	"IND A"			"IND B"			"IND C"			"IND D"			"IND E"		
	bkW	bhp	rpm	bkW	bhp	rpm	bkW	bhp	rpm	bkW	bhp	rpm	bkW	bhp	rpm
C1.6 NA	—	—	—	—	—	—	24.6	33.0	2800*	—	—	—	—	—	—
	—	—	—	—	—	—	26.5	35.5	3000*	—	—	—	—	—	—
C1.7 NA	—	—	—	—	—	—	23.6	31.6	2400*	—	—	—	—	—	—
	—	—	—	—	—	—	26.1	35.0	2600*	—	—	—	—	—	—
C2.2 T	—	—	—	—	—	—	30.0	40.2	2800	—	—	—	—	—	—
	—	—	—	—	—	—	36.4	48.8	2800	—	—	—	—	—	—
C2.2 TA	—	—	—	—	—	—	36.4	48.8	2800	—	—	—	—	—	—
	—	—	—	—	—	—	50.0	67.05	2800	—	—	—	—	—	—
C2.8 T, TA	—	—	—	—	—	—	45.0	60.0	2500	—	—	—	—	—	—
	—	—	—	—	—	—	55.0	74.0	2500	—	—	—	—	—	—
C3.4B T	—	—	—	—	—	—	45.0	60.3	2200	—	—	—	—	—	—
	—	—	—	—	—	—	47.0	63.0	2500	—	—	—	—	—	—
	—	—	—	—	—	—	50.0	67.0	2200	—	—	—	—	—	—
	—	—	—	—	—	—	55.4	74.3	2200 & 2500	—	—	—	—	—	—
C3.4B TA	—	—	—	—	—	—	63.0	84.5	2200	—	—	—	—	—	—
	—	—	—	—	—	—	66.0	88.5	2200 & 2500	—	—	—	—	—	—
	—	—	—	—	—	—	70.0	94.0	2200	—	—	—	—	—	—
	—	—	—	—	—	—	75.0	100.6	2200 & 2500	—	—	—	—	—	—
	—	—	—	—	—	—	—	—	—	83.0	111.3	2200	—	—	—
	—	—	—	—	—	—	—	—	—	86.0	115.3	2500	—	—	—
—	—	—	—	—	—	—	—	—	90.0	120.7	2200	—	—	—	

## Rating Conditions:

## Diesel Engines — up to 7.1 liter

All rating conditions are based on ISO/TR14396, inlet air standard conditions with a total barometric pressure of 100 kPa (29.5 in Hg), with a vapor pressure of 1 kPa (0.295 in Hg), and 25° C (77° F).

Performance measured using fuel to EPA specifications in 40 CFR Part 1065 and EU specifications in Directive 97/68/EC with a density of 0.845-0.850 kg/L @ 15° C (59° F) and fuel inlet temperature 40° C (104° F).

## Diesel Engines — greater than 7.1 liter

All rating conditions are based on SAE J1995, inlet air standard conditions of 99 kPa (29.31 in Hg) dry barometer and 25° C (77° F) temperature. Performance measured using a standard fuel with fuel gravity of 35° API having a lower heating value of 42 780 kJ/kg (18,390 btu/lb) when used at 29° C (84.2° F) with a density of 838.9 g/L.

## Diesel Engine Rating Definitions

## Explanation of Ratings A, B, C, D, and E:

- For an exact determination of the appropriate rating, contact your local Cat dealer. Engine rating obtained and presented in accordance with ISO 3046/1.

## IND-A (Continuous)

- Continuous heavy-duty service where the engine is operated at maximum power and speed up to 100% of the time without interruption or load cycling.

## IND-B

- For service where power and/or speed are cyclic (time at full load not to exceed 80%).

## IND-C (Intermittent)

- Intermittent service where maximum power and/or speed are cyclic (time at full load not to exceed 50%).

## IND-D

- For service where maximum power is required for periodic overloads (time at full load not to exceed 10% of the duty cycle).

## IND-E

- For service where maximum power is required for a short time for initial starting or sudden overload. For emergency service where standard power is unavailable (time at full load not to exceed 5% of the duty cycle).

T — Turbocharged

NA — Naturally Aspirated

bhp — Brake horsepower

bkW — Brake kilowatts

\*Denotes rating is available in EU and other global regulated and non-regulated areas (Non-U.S.).

## Cat Industrial Diesel Applications

Meets U.S. EPA Tier 4 Final, EU Stage IIIB or Stage IV emission standards

Model	Type	"IND A"			"IND B"			"IND C"			"IND D"			"IND E"				
		bkW	bhp	rpm	bkW	bhp	rpm	bkW	bhp	rpm	bkW	bhp	rpm	bkW	bhp	rpm		
C3.6	TA	—	—	—	—	—	—	—	55.0	<b>74.0</b>	2000-2400	—	—	—	—	—	—	
		—	—	—	—	—	—	—	100.0	<b>134.0</b>	2000-2400	—	—	—	—	—	—	
C4.4 ACERT	TA	—	—	—	85.9	<b>115.2</b>	2200	70.0	<b>93.9</b>	2200	—	—	—	—	—	—	—	
		—	—	—	91.0	<b>122.0</b>	2200	74.4	<b>99.8</b>	2200	—	—	—	—	—	—	—	
		—	—	—	92.6	<b>124.2</b>	2200	82.0	<b>109.9</b>	2200	—	—	—	—	—	—	—	
		—	—	—	—	—	—	85.9	<b>115.2</b>	2200	—	—	—	—	—	—	—	
		—	—	—	—	—	—	91.0	<b>122.0</b>	2200	—	—	—	—	—	—	—	
		—	—	—	—	—	—	92.6	<b>124.2</b>	2200	—	—	—	—	—	—	—	
		—	—	—	—	—	—	—	97.9	<b>131.3</b>	2200	—	—	—	—	—	—	—
		—	—	—	—	—	—	—	102.1	<b>136.9</b>	2200	—	—	—	—	—	—	—
		—	—	—	—	—	—	—	106.0	<b>142.1</b>	2200	—	—	—	—	—	—	—
C4.4 ACERT	TTA	—	—	—	105.0	<b>140.8</b>	2200	—	—	—	—	—	—	—	—	—	—	
		—	—	—	112.0	<b>150.0</b>	2200	—	—	—	—	—	—	—	—	—	—	
		—	—	—	—	—	—	117.0	<b>156.9</b>	2200	—	—	—	—	—	—	—	
C7.1 ACERT	TA	—	—	—	116	<b>156</b>	2200	—	—	—	—	—	—	—	—	—	—	
		—	—	—	129	<b>173</b>	2200	—	—	—	—	—	—	—	—	—	—	
C7.1 ACERT	TTA	—	—	—	—	—	—	151.0	<b>202.0</b>	2200	—	—	—	—	—	—	—	
		—	—	—	151	<b>202</b>	2200	—	—	—	—	—	—	—	—	—	—	
		—	—	—	168	<b>225</b>	2200	—	—	—	—	—	—	—	—	—	—	
C7.1 ACERT	TTA	—	—	—	—	—	—	186.0	<b>249.0</b>	2200	—	—	—	—	—	—	—	
		—	—	—	—	—	—	205.0	<b>275.0</b>	2200	—	—	—	—	—	—	—	
		—	—	—	—	—	—	225.0	<b>302.0</b>	2200	—	—	—	—	—	—	—	

### Rating Conditions:

#### Diesel Engines — up to 7.1 liter

All rating conditions are based on ISO/TR14396, inlet air standard conditions with a total barometric pressure of 100 kPa (**29.5 in Hg**), with a vapor pressure of 1 kPa (**0.295 in Hg**), and 25° C (**77° F**). Performance measured using fuel to EPA specifications in 40 CFR Part 1065 and EU specifications in Directive 97/68/EC with a density of 0.845-0.850 kg/L @ 15° C (**59° F**) and fuel inlet temperature 40° C (**104° F**).

#### Diesel Engines — greater than 7.1 liter

All rating conditions are based on SAE J1995, inlet air standard conditions of 99 kPa (**29.31 in Hg**) dry barometer and 25° C (**77° F**) temperature. Performance measured using a standard fuel with fuel gravity of 35° API having a lower heating value of 42 780 kJ/kg (**18,390 btu/lb**) when used at 29° C (**84.2° F**) with a density of 838.9 g/L.

### Diesel Engine Rating Definitions

#### Explanation of Ratings A, B, C, D, and E:

- For an exact determination of the appropriate rating, contact your local Cat dealer. Engine rating obtained and presented in accordance with ISO 3046/1.

#### IND-A (Continuous)

- Continuous heavy-duty service where the engine is operated at maximum power and speed up to 100% of the time without interruption or load cycling.

#### IND-B

- For service where power and/or speed are cyclic (time at full load not to exceed 80%).

#### IND-C (Intermittent)

- Intermittent service where maximum power and/or speed are cyclic (time at full load not to exceed 50%).

#### IND-D

- For service where maximum power is required for periodic overloads (time at full load not to exceed 10% of the duty cycle).

#### IND-E

- For service where maximum power is required for a short time for initial starting or sudden overload. For emergency service where standard power is unavailable (time at full load not to exceed 5% of the duty cycle).

TA — Turbo Aftercooled  
 TTA — Twin or Series Turbo Aftercooled  
 bhp — Brake horsepower  
 kW — Brake kilowatts

## Cat Industrial Diesel Applications

Meets U.S. EPA Tier 4 Final, EU Stage IIIB or Stage IV emission standards

Model	Type	"IND A"			"IND B"			"IND C"			"IND D"			"IND E"		
		bkW	bhp	rpm	bkW	bhp	rpm	bkW	bhp	rpm	bkW	bhp	rpm	bkW	bhp	rpm
C9.3 ACERT	TA	224	<b>300</b>	1800-2200	242	<b>325</b>	1800-2200	261	<b>350</b>	1800-2200	290	<b>389</b>	1800-2200	—	—	—
		—	—	—	—	—	—	—	—	—	298	<b>400</b>	2000	—	—	—
C13 ACERT	TA	287	<b>385</b>	1800-2100	309	<b>415</b>	1800-2100	328	<b>440</b>	1800-2100	354	<b>475</b>	1800-2100	388	<b>520</b>	1800-2100
C15 ACERT	TA	354	<b>475</b>	1800-2100	354	<b>475</b>	1800-2100	403	<b>540</b>	1800-2100	433	<b>580</b>	1800-2100	—	—	—
C18 ACERT	TA	429	<b>575</b>	1800-2000	447	<b>600</b>	1800-2000	470	<b>630</b>	1800-2000	—	—	—	—	—	—
C18 ACERT	TTA	—	—	—	—	—	—	563	<b>755</b>	1800	597	<b>800</b>	1800	—	—	—
C27 ACERT	TA	597	<b>800</b>	1800	653	<b>875</b>	1800	709	<b>950</b>	1800	783	<b>1050</b>	1800	—	—	—
C32 ACERT	TA	—	—	—	746	<b>1000</b>	1800	839	<b>1125</b>	1800	895	<b>1200</b>	1800	—	—	—

### Rating Conditions:

#### Diesel Engines — up to 7.1 liter

All rating conditions are based on ISO/TR14396, inlet air standard conditions with a total barometric pressure of 100 kPa (**29.5 in Hg**), with a vapor pressure of 1 kPa (**0.295 in Hg**), and 25° C (**77° F**). Performance measured using fuel to EPA specifications in 40 CFR Part 1065 and EU specifications in Directive 97/68/EC with a density of 0.845-0.850 kg/L @ 15° C (**59° F**) and fuel inlet temperature 40° C (**104° F**).

#### Diesel Engines — greater than 7.1 liter

All rating conditions are based on SAE J1995, inlet air standard conditions of 99 kPa (**29.31 in Hg**) dry barometer and 25° C (**77° F**) temperature. Performance measured using a standard fuel with fuel gravity of 35° API having a lower heating value of 42 780 kJ/kg (**18,390 btu/lb**) when used at 29° C (**84.2° F**) with a density of 838.9 g/L.

### Diesel Engine Rating Definitions

#### Explanation of Ratings A, B, C, D, and E:

- For an exact determination of the appropriate rating, contact your local Cat dealer. Engine rating obtained and presented in accordance with ISO 3046/1.

#### IND-A (Continuous)

- Continuous heavy-duty service where the engine is operated at maximum power and speed up to 100% of the time without interruption or load cycling.

#### IND-B

- For service where power and/or speed are cyclic (time at full load not to exceed 80%).

#### IND-C (Intermittent)

- Intermittent service where maximum power and/or speed are cyclic (time at full load not to exceed 50%).

#### IND-D

- For service where maximum power is required for periodic overloads (time at full load not to exceed 10% of the duty cycle).

#### IND-E

- For service where maximum power is required for a short time for initial starting or sudden overload. For emergency service where standard power is unavailable (time at full load not to exceed 5% of the duty cycle).

TA — Turbo Aftercooled  
TTA — Twin or Series Turbo Aftercooled  
bhp — Brake horsepower  
bkW — Brake kilowatts

## Cat Industrial Diesel Applications

### Other Global Regulated and Non-Regulated Areas or with U.S. EPA/EU Transitional Provisions

Model	Type	"IND A"			"IND B"			"IND C"			"IND D"			"IND E"		
		bkW	bhp	rpm	bkW	bhp	rpm	bkW	bhp	rpm	bkW	bhp	rpm	bkW	bhp	rpm
C0.5	NA	—	—	—	—	—	—	8.2	11.0	2800	—	—	—	—	—	—
		—	—	—	—	—	—	8.8	11.8	3000	—	—	—	—	—	—
		—	—	—	—	—	—	10.2	13.7	3600	—	—	—	—	—	—
C0.7	NA	—	—	—	—	—	—	12.2	16.4	2800	—	—	—	—	—	—
		—	—	—	—	—	—	13.2	17.7	3000	—	—	—	—	—	—
		—	—	—	—	—	—	15.3	20.5	3600	—	—	—	—	—	—
C1.1	NA	—	—	—	—	—	—	13.7	18.4	2200	—	—	—	—	—	—
		—	—	—	—	—	—	14.7	19.7	2200	—	—	—	—	—	—
		—	—	—	—	—	—	16.1	21.6	2600	—	—	—	—	—	—
		—	—	—	—	—	—	16.8	22.5	2800	—	—	—	—	—	—
		—	—	—	—	—	—	17.2	23.0	2600	—	—	—	—	—	—
		—	—	—	—	—	—	17.7	23.7	3000	—	—	—	—	—	—
		—	—	—	—	—	—	18.5	24.8	2800	—	—	—	—	—	—
		—	—	—	—	—	—	19.7	26.4	3000	—	—	—	—	—	—
C1.5	NA	—	—	—	—	—	—	21.0	28.2	3400	—	—	—	—	—	—
		—	—	—	—	—	—	20.7	27.8	2200	—	—	—	—	—	—
		—	—	—	—	—	—	22.3	29.9	2400	—	—	—	—	—	—
		—	—	—	—	—	—	23.4	31.4	2600	—	—	—	—	—	—
		—	—	—	—	—	—	24.4	32.7	2800	—	—	—	—	—	—
C1.5	T	—	—	—	—	—	—	25.1	33.7	3000	—	—	—	—	—	—
		—	—	—	—	—	—	23.1	31.0	2200	—	—	—	—	—	—
		—	—	—	—	—	—	25.2	33.8	2400	—	—	—	—	—	—
		—	—	—	—	—	—	27.3	36.6	2600	—	—	—	—	—	—
		—	—	—	—	—	—	29.4	39.4	2800	—	—	—	—	—	—
C1.6	NA	—	—	—	—	—	—	30.0	40.2	3000	—	—	—	—	—	—
		—	—	—	—	—	—	24.6	33.0	2800	—	—	—	—	—	—
		—	—	—	—	—	—	26.5	35.5	3000	—	—	—	—	—	—
C1.7	NA	—	—	—	—	—	—	23.6	31.6	2400	—	—	—	—	—	—
		—	—	—	—	—	—	26.1	35.0	2600	—	—	—	—	—	—

#### Rating Conditions:

##### Diesel Engines — up to 7.1 liter

All rating conditions are based on ISO/TR14396, inlet air standard conditions with a total barometric pressure of 100 kPa (29.5 in Hg), with a vapor pressure of 1 kPa (0.295 in Hg), and 25° C (77° F). Performance measured using fuel to EPA specifications in 40 CFR Part 1065 and EU specifications in Directive 97/68/EC with a density of 0.845-0.850 kg/L @ 15° C (59° F) and fuel inlet temperature 40° C (104° F).

##### Diesel Engines — greater than 7.1 liter

All rating conditions are based on SAE J1995, inlet air standard conditions of 99 kPa (29.31 in Hg) dry barometer and 25° C (77° F) temperature. Performance measured using a standard fuel with fuel gravity of 35° API having a lower heating value of 42 780 kJ/kg (18,390 btu/lb) when used at 29° C (84.2° F) with a density of 838.9 g/L.

#### Diesel Engine Rating Definitions

##### Explanation of Ratings A, B, C, D, and E:

- For an exact determination of the appropriate rating, contact your local Cat dealer. Engine rating obtained and presented in accordance with ISO 3046/1.

##### IND-A (Continuous)

- Continuous heavy-duty service where the engine is operated at maximum power and speed up to 100% of the time without interruption or load cycling.

##### IND-B

- For service where power and/or speed are cyclic (time at full load not to exceed 80%).

##### IND-C (Intermittent)

- Intermittent service where maximum power and/or speed are cyclic (time at full load not to exceed 50%).

##### IND-D

- For service where maximum power is required for periodic overloads (time at full load not to exceed 10% of the duty cycle).

##### IND-E

- For service where maximum power is required for a short time for initial starting or sudden overload. For emergency service where standard power is unavailable (time at full load not to exceed 5% of the duty cycle).

NA — Naturally Aspirated  
 T — Turbocharged  
 bhp — Brake horsepower  
 bkW — Brake kilowatts



## Cat Industrial Diesel Applications

### Other Global Regulated and Non-Regulated Areas, or U.S. EPA/EU Transitional Provisions

Model	Type	"IND A"			"IND B"			"IND C"			"IND D"			"IND E"		
		bkW	bhp	rpm	bkW	bhp	rpm	bkW	bhp	rpm	bkW	bhp	rpm	bkW	bhp	rpm
C2.2	NA	—	—	—	—	—	—	31.0	41.6	2200	—	—	—	—	—	—
		—	—	—	—	—	—	31.4	42.1	2600	—	—	—	—	—	—
		—	—	—	—	—	—	34.1	45.7	2400	—	—	—	—	—	—
		—	—	—	—	—	—	35.7	47.9	2600	—	—	—	—	—	—
		—	—	—	—	—	—	36.4	48.8	2800 & 3000	—	—	—	—	—	—
C2.2	T	—	—	—	—	—	—	36.3	48.7	2800	—	—	—	—	—	—
		—	—	—	—	—	—	40.0	53.3	2800	—	—	—	—	—	—
		—	—	—	—	—	—	43.0	57.7	2600	—	—	—	—	—	—
		—	—	—	—	—	—	44.7	60.0	2800	—	—	—	—	—	—
		—	—	—	—	—	—	45.5	61.0	3000	—	—	—	—	—	—
C2.2	TA	—	—	—	—	—	49.3	66.1	2800	—	—	—	—	—	—	
C2.8	T, TA	—	—	—	—	—	55.0	74.0	2200-2500	—	—	—	—	—	—	
3054C	NA	—	—	—	—	—	—	52.0-64.0	69.7-85.8	2000-2400	—	—	—	—	—	—
		—	—	—	—	—	—	62.0-74.5	83.0-99.9	2000-2400	—	—	—	—	—	—
3054C	TA	—	—	—	—	—	—	78.0-97.0	104.5-130	2000-2300	—	—	—	—	—	—
		—	—	—	—	—	—	55.0	74.0	2200-2400	—	—	—	—	—	—
C3.6	TA	—	—	—	—	—	—	100	134	2200-2400	—	—	—	—	—	—
		—	—	—	—	—	—	—	—	—	—	—	—	—	—	—

#### Rating Conditions:

##### Diesel Engines — up to 7.1 liter

All rating conditions are based on ISO/TR14396, inlet air standard conditions with a total barometric pressure of 100 kPa (29.5 in Hg), with a vapor pressure of 1 kPa (0.295 in Hg), and 25° C (77° F). Performance measured using fuel to EPA specifications in 40 CFR Part 1065 and EU specifications in Directive 97/68/EC with a density of 0.845-0.850 kg/L @ 15° C (59° F) and fuel inlet temperature 40° C (104° F).

##### Diesel Engines — greater than 7.1 liter

All rating conditions are based on SAE J1995, inlet air standard conditions of 99 kPa (29.31 in Hg) dry barometer and 25° C (77° F) temperature. Performance measured using a standard fuel with fuel gravity of 35° API having a lower heating value of 42 780 kJ/kg (18,390 btu/lb) when used at 29° C (84.2° F) with a density of 838.9 g/L.

#### Diesel Engine Rating Definitions

##### Explanation of Ratings A, B, C, D, and E:

- For an exact determination of the appropriate rating, contact your local Cat dealer. Engine rating obtained and presented in accordance with ISO 3046/1.

##### IND-A (Continuous)

- Continuous heavy-duty service where the engine is operated at maximum power and speed up to 100% of the time without interruption or load cycling.

##### IND-B

- For service where power and/or speed are cyclic (time at full load not to exceed 80%).

##### IND-C (Intermittent)

- Intermittent service where maximum power and/or speed are cyclic (time at full load not to exceed 50%).

##### IND-D

- For service where maximum power is required for periodic overloads (time at full load not to exceed 10% of the duty cycle).

##### IND-E

- For service where maximum power is required for a short time for initial starting or sudden overload. For emergency service where standard power is unavailable (time at full load not to exceed 5% of the duty cycle).

NA — Naturally Aspirated  
T — Turbocharged  
TA — Turbo Aftercooled  
bhp — Brake horsepower  
bkW — Brake kilowatts

## Cat Industrial Diesel Applications

### Other Global Regulated and Non-Regulated Areas, or U.S. EPA/EU Transitional Provisions

Model	Type	"IND A"			"IND B"			"IND C"			"IND D"			"IND E"		
		bkW	bhp	rpm	bkW	bhp	rpm	bkW	bhp	rpm	bkW	bhp	rpm	bkW	bhp	rpm
C4.4	NA	—	—	—	—	—	—	54.0	72.4	2200	—	—	—	—	—	—
		—	—	—	—	—	—	56.0	75.0	2200	—	—	—	—	—	—
C4.4	T	—	—	—	—	—	—	55.5-74.5	74.4-99.9	2200-2400	—	—	—	—	—	—
C4.4	TA	—	—	—	—	—	—	68.0-83.0	91.2-111.3	2200-2400	—	—	—	—	—	—
C4.4 ACERT	T	—	—	—	—	—	—	68.0-74.5	91.2-99.0	2200	—	—	—	—	—	—
C4.4 ACERT	TA	—	—	—	—	—	—	74.5-106	99.5-142	2200	—	—	—	—	—	—
C7 ACERT	TA	—	—	—	168	225	1800-2200	186	250	1800-2200	224	300	2100-2200	—	—	—
		—	—	—	—	—	—	205	275	1800-2200	—	—	—	—	—	—
C7.1	TA	—	—	—	—	—	—	112	150	2200	—	—	—	—	—	—
		—	—	—	—	—	—	129	172	2000	—	—	—	—	—	—
		—	—	—	—	—	—	118	158	2000	—	—	—	—	—	—
		—	—	—	—	—	—	145	194	2200	—	—	—	—	—	—
C7.1 ACERT	TA	—	—	—	—	—	—	162	220	2200	—	—	—	—	—	—
		—	—	—	—	—	—	116	156	2200	—	—	—	—	—	—
		—	—	—	—	—	—	129	173	2200-2500	—	—	—	—	—	—
		—	—	—	—	—	—	151	202	2200	—	—	—	—	—	—
		—	—	—	—	—	—	168	225	2200	—	—	—	—	—	—
—	—	—	—	—	—	186	250	2200	—	—	—	—	—	—		
—	—	—	—	—	—	205	275	2200	—	—	—	—	—	—		

#### Rating Conditions:

##### Diesel Engines — up to 7.1 liter

All rating conditions are based on ISO/TR14396, inlet air standard conditions with a total barometric pressure of 100 kPa (29.5 in Hg), with a vapor pressure of 1 kPa (0.295 in Hg), and 25° C (77° F). Performance measured using fuel to EPA specifications in 40 CFR Part 1065 and EU specifications in Directive 97/68/EC with a density of 0.845-0.850 kg/L @ 15° C (59° F) and fuel inlet temperature 40° C (104° F).

##### Diesel Engines — greater than 7.1 liter

All rating conditions are based on SAE J1995, inlet air standard conditions of 99 kPa (29.31 in Hg) dry barometer and 25° C (77° F) temperature. Performance measured using a standard fuel with fuel gravity of 35° API having a lower heating value of 42 780 kJ/kg (18,390 btu/lb) when used at 29° C (84.2° F) with a density of 838.9 g/L.

#### Diesel Engine Rating Definitions

##### Explanation of Ratings A, B, C, D, and E:

- For an exact determination of the appropriate rating, contact your local Cat dealer. Engine rating obtained and presented in accordance with ISO 3046/1.

##### IND-A (Continuous)

- Continuous heavy-duty service where the engine is operated at maximum power and speed up to 100% of the time without interruption or load cycling.

##### IND-B

- For service where power and/or speed are cyclic (time at full load not to exceed 80%).

##### IND-C (Intermittent)

- Intermittent service where maximum power and/or speed are cyclic (time at full load not to exceed 50%).

##### IND-D

- For service where maximum power is required for periodic overloads (time at full load not to exceed 10% of the duty cycle).

##### IND-E

- For service where maximum power is required for a short time for initial starting or sudden overload. For emergency service where standard power is unavailable (time at full load not to exceed 5% of the duty cycle).

TA — Turbo Aftercooled  
bhp — Brake horsepower  
bkW — Brake kilowatts

## Cat Industrial Diesel Applications

## Other Global Regulated and Non-Regulated Areas

Model	Type	"IND A"			"IND B"			"IND C"			"IND D"			"IND E"		
		bkW	bhp	rpm	bkW	bhp	rpm	bkW	bhp	rpm	bkW	bhp	rpm	bkW	bhp	rpm
C9 ACERT	TA	205	275	1800-2200	223	300	1800-2200	242	325	1800-2200	280	375	1800-2200	—	—	—
		—	—	—	—	—	—	261	350	1800-2200	—	—	—	—	—	—
C11 ACERT	TA	242	325	1800-2100	261	350	1800-2100	287	385	1800-2100	313	420	1800-2100	336	450	1800-2100
3406C	TA	—	—	—	—	—	—	298	400	1800-2100	347	465	1800-2100	—	—	—
		—	—	—	—	—	—	343	460	2100	—	—	—	—	—	—
C13 ACERT	TA	287	385	1800-2100	310.0	415	1800-2100	328	440	1800-2100	354	475	1800-2100	388	520	1800-2100
C15 ACERT	TA	328	440	1800-2100	354.0	475	1800-2100	403	540	1800-2100	433	580	1800-2100	444	595	1800-2100
C18 ACERT	TA	429	575	1800-2100	447.5	600	1800-2100	470	630	1800-2100	—	—	—	—	—	—
		447	600	1800-1900	—	—	—	—	—	—	—	—	—	—	—	—
C18 ACERT	TTA	—	—	—	—	—	—	522	700	1800-2100	571	765	1800-2100	597	800	1800-2100
		—	—	—	—	—	—	563	755	1800-1900	597	800	1800-1900	—	—	—
C27 ACERT	TA	597	800	1800-2100	653.0	875	1800-2100	708	950	1800-2100	783	1050	1800-2100	858	1150	1800-2100
C32 ACERT	TA	—	—	—	708.0	950	1800-2100	839	1125	1800-2100	895	1200	1800-2100	1007	1350	1800-2100

## Rating Conditions:

## Diesel Engines — up to 7.1 liter

All rating conditions are based on ISO/TR14396, inlet air standard conditions with a total barometric pressure of 100 kPa (29.5 in Hg), with a vapor pressure of 1 kPa (0.295 in Hg), and 25° C (77° F). Performance measured using fuel to EPA specifications in 40 CFR Part 1065 and EU specifications in Directive 97/68/EC with a density of 0.845-0.850 kg/L @ 15° C (59° F) and fuel inlet temperature 40° C (104° F).

## Diesel Engines — greater than 7.1 liter

All rating conditions are based on SAE J1995, inlet air standard conditions of 99 kPa (29.31 in Hg) dry barometer and 25° C (77° F) temperature. Performance measured using a standard fuel with fuel gravity of 35° API having a lower heating value of 42 780 kJ/kg (18,390 btu/lb) when used at 29° C (84.2° F) with a density of 838.9 g/L.

## Diesel Engine Rating Definitions

## Explanation of Ratings A, B, C, D, and E:

- For an exact determination of the appropriate rating, contact your local Cat dealer. Engine rating obtained and presented in accordance with ISO 3046/1.

## IND-A (Continuous)

- Continuous heavy-duty service where the engine is operated at maximum power and speed up to 100% of the time without interruption or load cycling.

## IND-B

- For service where power and/or speed are cyclic (time at full load not to exceed 80%).

## IND-C (Intermittent)

- Intermittent service where maximum power and/or speed are cyclic (time at full load not to exceed 50%).

## IND-D

- For service where maximum power is required for periodic overloads (time at full load not to exceed 10% of the duty cycle).

## IND-E

- For service where maximum power is required for a short time for initial starting or sudden overload. For emergency service where standard power is unavailable (time at full load not to exceed 5% of the duty cycle).

TA — Turbo Aftercooled  
TTA — Twin or Series Turbo Aftercooled  
bhp — Brake horsepower  
bkW — Brake kilowatts

## Cat Industrial Diesel Applications

### Other Global Regulated and Non-Regulated Areas

Model	Type	"IND A"			"IND B"			"IND C"			"IND D"			"IND E"		
		bkW	bhp	rpm	bkW	bhp	rpm	bkW	bhp	rpm	bkW	bhp	rpm	bkW	bhp	rpm
3508	TA	507	680	1200	—	—	—	612	820	1300	—	—	—	—	—	—
		578	775	1800	—	—	—	634	850	1800	—	—	—	—	—	—
		638	855	1800	—	—	—	746	1000	1800	—	—	—	—	—	—
3508B	TA	746	1000	1800	783	1050	1800	820	1100	1800	—	—	—	—	—	—
3512	TA	761	1020	1200	—	—	—	858	1150	1300	—	—	—	—	—	—
		955	1280	1800	—	—	—	1119	1500	1800	—	—	—	—	—	—
3512B	TA	1119	1500	1800	1174	1575	1800	1231	1650	1800	—	—	—	—	—	—
3512C	TA	1120	1500	1800	—	—	—	—	—	—	—	—	—	—	—	—
3516	TA	1011	1355	1200	—	—	—	1242	1665	1300	—	—	—	—	—	—
		1275	1710	1800	—	—	—	1492	2000	1800	—	—	—	—	—	—
3516B	TA	1492	2000	1800	1566	2100	1800	1640	2200	1800	—	—	—	—	—	—
		1490	1998	750	—	—	—	—	—	—	—	—	—	—	—	—
		1560	2092	800	—	—	—	—	—	—	—	—	—	—	—	—
		1730	2319	900	—	—	—	—	—	—	—	—	—	—	—	—
3606	TA	1850	2481	1000	—	—	—	—	—	—	—	—	—	—	—	—
		2080	2787	800	—	—	—	—	—	—	—	—	—	—	—	—
		2300	3080	900	—	—	—	—	—	—	—	—	—	—	—	—
		2460	3300	1000	—	—	—	—	—	—	—	—	—	—	—	—
3608	TA	2980	3996	750	—	—	—	—	—	—	—	—	—	—	—	—
		3120	4184	800	—	—	—	—	—	—	—	—	—	—	—	—
		3460	4640	900	—	—	—	—	—	—	—	—	—	—	—	—
		3700	4962	1000	—	—	—	—	—	—	—	—	—	—	—	—
3612	TA	2980	3996	750	—	—	—	—	—	—	—	—	—	—	—	—
		3120	4184	800	—	—	—	—	—	—	—	—	—	—	—	—
		3460	4640	900	—	—	—	—	—	—	—	—	—	—	—	—
3616	TA	3700	4962	1000	—	—	—	—	—	—	—	—	—	—	—	—
		4160	5579	800	—	—	—	—	—	—	—	—	—	—	—	—
		4600	6169	900	—	—	—	—	—	—	—	—	—	—	—	—
3616B	TA	4920	6598	1000	—	—	—	—	—	—	—	—	—	—	—	—
		4920	6598	1000	—	—	—	—	—	—	—	—	—	—	—	—

#### Rating Conditions:

##### Diesel Engines — up to 7.1 liter

All rating conditions are based on ISO/TR14396, inlet air standard conditions with a total barometric pressure of 100 kPa (29.5 in Hg), with a vapor pressure of 1 kPa (0.295 in Hg), and 25° C (77° F). Performance measured using fuel to EPA specifications in 40 CFR Part 1065 and EU specifications in Directive 97/68/EC with a density of 0.845-0.850 kg/L @ 15° C (59° F) and fuel inlet temperature 40° C (104° F).

##### Diesel Engines — greater than 7.1 liter

All rating conditions are based on SAE J1995, inlet air standard conditions of 99 kPa (29.31 in Hg) dry barometer and 25° C (77° F) temperature. Performance measured using a standard fuel with fuel gravity of 35° API having a lower heating value of 42 780 kJ/kg (18,390 btu/lb) when used at 29° C (84.2° F) with a density of 838.9 g/L.

#### Diesel Engine Rating Definitions

##### Explanation of Ratings A, B, C, D, and E:

- For an exact determination of the appropriate rating, contact your local Cat dealer. Engine rating obtained and presented in accordance with ISO 3046/1.

##### IND-A (Continuous)

- Continuous heavy-duty service where the engine is operated at maximum power and speed up to 100% of the time without interruption or load cycling.

##### IND-B

- For service where power and/or speed are cyclic (time at full load not to exceed 80%).

##### IND-C (Intermittent)

- Intermittent service where maximum power and/or speed are cyclic (time at full load not to exceed 50%).

##### IND-D

- For service where maximum power is required for periodic overloads (time at full load not to exceed 10% of the duty cycle).

##### IND-E

- For service where maximum power is required for a short time for initial starting or sudden overload. For emergency service where standard power is unavailable (time at full load not to exceed 5% of the duty cycle).

TA — Turbo Aftercooled  
bhp — Brake horsepower  
bkW — Brake kilowatts

## Cat Industrial Diesel Applications

### Cat Diesel Engines for Fire Pump Packages

Model	No. of Cylinders	1460 rpm		1500 rpm		1750 rpm		1900 rpm		2100 rpm		2200 rpm		2300 rpm	
		bkW	bhp	bkW	bhp	bkW	bhp	bkW	bhp	bkW	bhp	bkW	bhp	bkW	bhp
<b>C18 ACERT*</b> TA	6	—	—	—	—	597	<b>800</b>	597	<b>800</b>	597	<b>800</b>	—	—	—	—
<b>C18 ACERT**</b> TA	6	—	—	—	—	522	<b>700</b>	522	<b>700</b>	522	<b>700</b>	—	—	—	—
<b>C18 ACERT***</b> TA	6	—	—	—	—	447	<b>600</b>	447	<b>600</b>	447	<b>600</b>	—	—	—	—
<b>3406C***</b> TA	6	—	—	522	<b>700</b>	—	—	—	—	—	—	—	—	—	—
<b>3406C Wet Manifolds***</b> TA	6	—	—	—	—	276	<b>370</b>	—	—	359	<b>482</b>	—	—	339	<b>455</b>
		—	—	—	—	343	<b>460</b>	—	—	—	—	—	—	—	—
		—	—	—	—	218	<b>292</b>	—	—	321	<b>430</b>	—	—	—	—
		—	—	—	—	313	<b>420</b>	—	—	—	—	—	—	—	—
<b>3412C Wet Manifolds****</b> TA	12	—	—	—	—	476	<b>638</b>	551	<b>739</b>	551	<b>739</b>	—	—	—	—
<b>3508****</b> TA	8	709	<b>950</b>	—	—	794	<b>1065</b>	—	—	—	—	—	—	—	—
<b>3512****</b> TA	12	1066	<b>1430</b>	—	—	1193	<b>1600</b>	—	—	—	—	—	—	—	—
<b>3516****</b> TA	16	1417	<b>1900</b>	—	—	1480	<b>1985</b>	—	—	—	—	—	—	—	—

\*U.S. EPA Tier 2 Equivalent, FM Approved, UL Listed

\*\*U.S. EPA Tier 3 Equivalent, FM Approved, UL Listed

\*\*\*Non-EPA Certified, FM Approved, UL Listed

\*\*\*\*Non-EPA Certified, Not FM Approved, Not UL Listed

TA — Turbo Aftercooled

#### Rating Definition:

**Standby:** Fire pump engine ratings represent the output which may be utilized to drive stationary fire pumps where the pumping equipment has been sized according to ULI and FM procedures.

## Cat Oil and Gas Engines

### Gas Industrial Ratings

Model	900 rpm		1000 rpm		1200 rpm		1400 rpm		1500 rpm		1600 rpm		1800 rpm		
	bkW	bhp	bkW	bhp	bkW	bhp	bkW	bhp	bkW	bhp	bkW	bhp	bkW	bhp	
G3304 NA	—	—	—	—	—	—	—	—	—	—	—	—	—	71	95
G3306 NA	—	—	—	—	—	—	—	—	—	—	—	—	—	108	145
G3306 TAA	—	—	—	—	—	—	—	—	—	—	—	—	—	157	211
G3306 TAA <sup>1</sup>	—	—	—	—	—	—	—	—	—	—	—	—	—	157	211
G3306 T	—	—	—	—	—	—	—	—	—	—	—	—	—	112	150
G3306 TA <sup>1</sup>	—	—	—	—	—	—	—	—	—	—	—	—	—	151	203
G3306 TA <sup>1</sup>	—	—	—	—	—	—	—	—	—	—	—	—	—	164	220
G3306B NA	—	—	—	—	—	—	—	—	—	—	—	—	—	108	145
G3306B TA <sup>1</sup>	—	—	—	—	—	—	—	—	—	—	—	—	—	153	205
G3406 NA	—	—	—	—	—	—	—	—	—	—	—	—	—	160	215
G3406 TA <sup>1</sup>	—	—	—	—	—	—	—	—	—	—	—	—	—	206	276
G3406 TA <sup>1</sup>	—	—	—	—	—	—	—	—	—	—	—	—	—	242	325
G3408 NA	—	—	—	—	—	—	—	—	—	—	—	—	—	190	255
G3408 TA <sup>1</sup>	—	—	—	—	—	—	—	—	—	249	332	—	—	—	—
G3408 TA <sup>1</sup>	—	—	—	—	—	—	—	—	—	—	—	—	—	298	400
G3408C LE <sup>1</sup>	—	—	—	—	—	—	—	—	—	—	—	—	—	317	425
G3412 TA <sup>1</sup>	—	—	—	—	—	—	—	—	—	373	500	—	—	—	—
G3412 TA <sup>1</sup>	—	—	—	—	—	—	—	—	—	—	—	—	—	448	600
G3412C LE <sup>1</sup>	—	—	—	—	—	—	—	—	—	—	—	—	—	475	637

<sup>1</sup> 54° C (130° F) water to aftercooler.

Ratings listed are for 25° C (77° F) ambient temperature, 152 m (500 ft) altitude, and pipeline quality gas.

- NA — Naturally Aspirated
- T — Turbocharged
- TA — Turbo Aftercooled
- TAA — Twin or Series Turbo Aftercooled
- LE — Low Emissions
- bhp — Brake horsepower
- bkW — Brake kilowatts

#### Rating Definition:

**Continuous:** Output available without varying load for an unlimited time. Continuous power in accordance with ISO 8528, ISO 3046-1, AS2789, DIN6271, and BS5514.

## Cat Oil and Gas Engines

## Gas Industrial Ratings

Model	720 rpm		750 rpm		1000 rpm		1200 rpm		1400 rpm		1800 rpm	
	bkW	bhp	bkW	bhp	bkW	bhp	bkW	bhp	bkW	bhp	bkW	bhp
CG137-8	—	—	—	—	—	—	—	—	—	—	298	400
CG137-12	—	—	—	—	—	—	—	—	—	—	447	600
G3508 TA <sup>1</sup>	—	—	—	—	—	—	391	524	—	—	—	—
G3508 LE <sup>1</sup>	—	—	—	—	—	—	—	—	500	670	—	—
G3508B LE <sup>1,2,3</sup>	—	—	—	—	—	—	—	—	515	690	—	—
G3512 TA <sup>1</sup>	—	—	—	—	—	—	589	790	—	—	—	—
G3512 LE <sup>1</sup>	—	—	—	—	—	—	642	860	—	—	—	—
G3512 LE <sup>1</sup>	—	—	—	—	—	—	—	—	749	1004	—	—
G3512B LE <sup>1,2,3</sup>	—	—	—	—	—	—	—	—	772	1035	—	—
G3516 NA	—	—	—	—	—	—	492	660	—	—	—	—
G3516 TA <sup>1</sup>	—	—	—	—	—	—	783	1050	—	—	—	—
G3516 LE <sup>1</sup>	—	—	—	—	—	—	858	1150	—	—	—	—
G3516 LE <sup>1</sup>	—	—	—	—	—	—	—	—	1000	1340	—	—
G3516B LE <sup>1,2,3</sup>	—	—	—	—	—	—	—	—	1029	1380	—	—
G3520B LE <sup>1,2,3</sup>	—	—	—	—	—	—	1104	1480	—	—	—	—
G3520B LE <sup>1,2,3</sup>	—	—	—	—	—	—	—	—	1286	1725	—	—
G3606 LE <sup>1,2,4</sup>	—	—	—	—	1324	1775	—	—	—	—	—	—
G3606 LE <sup>4,6</sup>	—	—	—	—	1368	1835	—	—	—	—	—	—
G3606 LE <sup>4,5</sup>	—	—	—	—	1413	1895	—	—	—	—	—	—
G3606 A4	—	—	—	—	1398-1499	1875-2010	—	—	—	—	—	—
G3608 LE <sup>1,2,4</sup>	—	—	—	—	1767	2370	—	—	—	—	—	—
G3608 LE <sup>4,6</sup>	—	—	—	—	1823	2445	—	—	—	—	—	—
G3608 LE <sup>4,5</sup>	—	—	—	—	1879	2520	—	—	—	—	—	—
G3608 A4	—	—	—	—	1864-1995	2500-2675	—	—	—	—	—	—
G3612 LE <sup>1,2,4</sup>	—	—	—	—	2647	3550	—	—	—	—	—	—
G3612 LE <sup>4,6</sup>	—	—	—	—	2733	3665	—	—	—	—	—	—
G3612 LE <sup>4,5</sup>	—	—	—	—	2822	3785	—	—	—	—	—	—
G3612 A4	—	—	—	—	2796-2983	3750-4000	—	—	—	—	—	—
G3616 LE <sup>1,2,4</sup>	—	—	—	—	3531	4735	—	—	—	—	—	—
G3616 LE <sup>4,6</sup>	—	—	—	—	3647	4890	—	—	—	—	—	—
G3616 LE <sup>4,5</sup>	—	—	—	—	3762	5045	—	—	—	—	—	—
G3616 A4	—	—	—	—	3729-3990	5000-5350	—	—	—	—	—	—
G12CM34 TA	5040	6759	5040	6759	—	—	—	—	—	—	—	—
G16CM34 TA	6720	9012	6720	9012	—	—	—	—	—	—	—	—
G20CM34 TA	10 000	13,410	10 000	13,410	—	—	—	—	—	—	—	—

<sup>1</sup> 54° C (130° F) water to aftercooler.<sup>2</sup> 250 mg/N·m<sup>3</sup> dry No<sub>x</sub> NTE emissions (corrected to 5% O<sub>2</sub>).<sup>3</sup> 500 mg/N·m<sup>3</sup> dry No<sub>x</sub> NTE emissions (corrected to 5% O<sub>2</sub>).<sup>4</sup> 350 mg/N·m<sup>3</sup> dry No<sub>x</sub> NTE emissions (corrected to 5% O<sub>2</sub>).<sup>5</sup> 32° C (90° F) aftercooler water and 88° C (190° F) jacket water.<sup>6</sup> 43° C (109° F) aftercooler water and 88° C (190° F) jacket water.

Ratings listed are for 25° C (77° F) ambient temperature, 152 m (500 ft) altitude, and pipeline quality gas.

NA — Naturally Aspirated

TA — Turbo Aftercooled

LE — Low Emissions

bhp — Brake horsepower

bkW — Brake kilowatts

**Rating Definition:****Continuous:** Output available without varying load for an unlimited time. Continuous power in accordance with ISO 8528, ISO 3046-1, AS2789, DIN6271, and BS5514.

## CM Power Generation Onshore

### Emissions according to WB2

CM Model	Fuel Type	Output Range		Speed	Frequency	Bore x Stroke		Fuel Efficiency		Crude Oil/ Heavy Fuel Operation at COP
		kW	hp	rpm		mm	in	g/kWh	MJ/kWh	
6CM20C	Diesel	1020	1368	900	60	200 x 300	7.9 x 11.8	189	8.07	x
6CM20C	Diesel	1140	1529	1000	50	200 x 300	7.9 x 11.8	190	8.11	x
8CM20C	Diesel	1360	1824	900	60	200 x 300	7.9 x 11.8	189	8.07	x
8CM20C	Diesel	1520	2038	1000	50	200 x 300	7.9 x 11.8	190	8.11	x
9CM20C	Diesel	1530	2052	900	60	200 x 300	7.9 x 11.8	189	8.07	x
9CM20C	Diesel	1710	2293	1000	50	200 x 300	7.9 x 11.8	190	8.11	x
6CM25C	Diesel	1800	2414	720	60	255 x 400	10 x 15.7	185	7.90	x
6CM25C	Diesel	1800	2414	750	50	255 x 400	10 x 15.7	185	7.90	x
8CM25C	Diesel	2400	3218	720	60	255 x 400	10 x 15.7	185	7.90	x
8CM25C	Diesel	2400	3218	750	50	255 x 400	10 x 15.7	185	7.90	x
9CM25C	Diesel	2700	3621	720	60	255 x 400	10 x 15.7	185	7.90	x
9CM25C	Diesel	2700	3621	750	50	255 x 400	10 x 15.7	185	7.90	x
6CM32E	Diesel	3000	4023	720	60	320 x 480	12.6 x 18.9	179	7.64	x
6CM32E	Diesel	3000	4023	750	50	320 x 480	12.6 x 18.9	179	7.64	x
8CM32E	Diesel	4000	5364	720	60	320 x 480	12.6 x 18.9	179	7.64	x
8CM32E	Diesel	4000	5364	750	50	320 x 480	12.6 x 18.9	179	7.64	x
9CM32E	Diesel	4500	6035	720	60	320 x 480	12.6 x 18.9	179	7.64	x
9CM32E	Diesel	4500	6035	750	50	320 x 480	12.6 x 18.9	179	7.64	x
12CM32C	Diesel	6000	8046	720	60	320 x 460	12.6 x 18.1	177	7.56	x
12CM32C	Diesel	6000	8046	750	50	320 x 460	12.6 x 18.1	178	7.60	x
16CM32C	Diesel	8000	10,728	720	60	320 x 460	12.6 x 18.1	177	7.56	x
16CM32C	Diesel	8000	10,728	750	50	320 x 460	12.6 x 18.1	178	7.60	x
6CM34DF	Dual Fuel	3000	4023	720	60	340 x 460	13.4 x 18.1	188	7.71*	x
6CM34DF	Dual Fuel	3000	4023	750	50	340 x 460	13.4 x 18.1	188	7.71*	x
8CM34DF	Dual Fuel	4000	5364	720	60	340 x 460	13.4 x 18.1	188	7.71*	x
8CM34DF	Dual Fuel	4000	5364	750	50	340 x 460	13.4 x 18.1	188	7.71*	x
9CM34DF	Dual Fuel	4500	6035	720	60	340 x 460	13.4 x 18.1	188	7.71*	x
9CM34DF	Dual Fuel	4500	6035	750	50	340 x 460	13.4 x 18.1	188	7.71*	x
6CM43C	Diesel	5640	7563	514	60	430 x 610	16.9 x 24	174	7.43	x
6CM43C	Diesel	5640	7563	500	50	430 x 610	16.9 x 24	174	7.43	x
7CM43C	Diesel	6580	8824	514	60	430 x 610	16.9 x 24	174	7.43	x
7CM43C	Diesel	6580	8824	500	50	430 x 610	16.9 x 24	174	7.43	x

\*Heat rate (MJ/kWh) for gaseous fuel.

#### NOTES:

- Ratings: Continuous power based on ISO 3046-1 standard reference conditions.
- Power output: May require adjustment for values other than ISO 3046-1 standard reference conditions.
- Fuel as specified per ISO 8217. Limiting Caterpillar specification for fuel is VD8738 for crude oil operation at continuous power operation (COP).
- Fuel consumption: Based on ISO 3046-1 standard reference conditions of 25° C (77° F) and 100 kPa (29.61 in Hg), including one engine-driven lube oil pump, with 5% tolerance and LCV = 42 700 kJ/kg (18,358 Btu/lb).
- Dual Fuel (DF) engines: Specific fuel consumption (g/kWh) for liquid fuel; heat rate MJ/kWh for gaseous fuel.
- Generator efficiency: Efficiency of 97.0% (96.0% for complete CM20 and CM25 model range, and for 6CM32, 8CM32, 9CM32) based on power factor 0.8 with medium voltage class generator; actual efficiency will depend on generator selection.
- Crude oil operation only at continuous power generation.



## CM Power Generation Onshore

## Emissions according to WB2

CM Model	Fuel Type	Output Range		Speed	Frequency	Bore x Stroke		Fuel Efficiency		Crude Oil/ Heavy Fuel Operation at COP
		kW	hp	rpm		mm	in	g/kWh	MJ/kWh	
8CM43C	Diesel	7520	<b>10,084</b>	514	60	430 x 610	<b>16.9 x 24</b>	174	7.43	x
8CM43C	Diesel	7520	<b>10,084</b>	500	50	430 x 610	<b>16.9 x 24</b>	174	7.43	x
9CM43C	Diesel	8460	<b>11,345</b>	514	60	430 x 610	<b>16.9 x 24</b>	174	7.43	x
9CM43C	Diesel	8460	<b>11,345</b>	500	50	430 x 610	<b>16.9 x 24</b>	174	7.43	x
12CM43C	Diesel	11 280	<b>15,127</b>	514	60	430 x 610	<b>16.9 x 24</b>	173	7.39	x
12CM43C	Diesel	11 280	<b>15,127</b>	500	50	430 x 610	<b>16.9 x 24</b>	173	7.39	x
16CM43C	Diesel	15 040	<b>20,169</b>	514	60	430 x 610	<b>16.9 x 24</b>	173	7.39	x
16CM43C	Diesel	15 040	<b>20,169</b>	500	50	430 x 610	<b>16.9 x 24</b>	173	7.39	x
6CM46DF	Dual Fuel	5400	<b>7241</b>	514	60	460 x 610	<b>18.1 x 24</b>	186	7.27*	x
6CM46DF	Dual Fuel	5400	<b>7241</b>	500	50	460 x 610	<b>18.1 x 24</b>	186	7.27*	x
7CM46DF	Dual Fuel	6300	<b>8448</b>	514	60	460 x 610	<b>18.1 x 24</b>	186	7.27*	x
7CM46DF	Dual Fuel	6300	<b>8448</b>	500	50	460 x 610	<b>18.1 x 24</b>	186	7.27*	x
8CM46DF	Dual Fuel	7200	<b>9655</b>	514	60	460 x 610	<b>18.1 x 24</b>	186	7.27*	x
8CM46DF	Dual Fuel	7200	<b>9655</b>	500	50	460 x 610	<b>18.1 x 24</b>	186	7.27*	x
9CM46DF	Dual Fuel	8100	<b>10,862</b>	514	60	460 x 610	<b>18.1 x 24</b>	186	7.27*	x
9CM46DF	Dual Fuel	8100	<b>10,862</b>	500	50	460 x 610	<b>18.1 x 24</b>	186	7.27*	x
12CM46DF	Dual Fuel	10 800	<b>14,483</b>	514	60	460 x 610	<b>18.1 x 24</b>	184	7.27*	x
12CM46DF	Dual Fuel	10 800	<b>14,483</b>	500	50	460 x 610	<b>18.1 x 24</b>	184	7.27*	x
16CM46DF	Dual Fuel	14 400	<b>19,310</b>	514	60	460 x 610	<b>18.1 x 24</b>	184	7.27*	x
16CM46DF	Dual Fuel	14 400	<b>19,310</b>	500	50	460 x 610	<b>18.1 x 24</b>	184	7.27*	x

## Onshore only:

G16CM34	Natural Gas	6720	<b>9012</b>	720	60	340 x 420	<b>13.4 x 16.5</b>	N/A	7.53	
G16CM34	Natural Gas	6720	<b>9012</b>	750	50	340 x 420	<b>13.4 x 16.5</b>	N/A	7.83	
G20CM34	Natural Gas	10 000	<b>13,410</b>	720	60	340 x 420	<b>13.4 x 16.5</b>	N/A	7.22	
G20CM34	Natural Gas	10 000	<b>13,410</b>	750	50	340 x 420	<b>13.4 x 16.5</b>	N/A	7.26	

\*Heat rate (MJ/kWh) for gaseous fuel.

## NOTES:

- Ratings: Continuous power based on ISO 3046-1 standard reference conditions.
- Power output: May require adjustment for values other than ISO 3046-1 standard reference conditions.
- Fuel as specified per ISO 8217. Limiting Caterpillar specification for fuel is VD8738 for crude oil operation at continuous power operation (COP).
- Fuel consumption: Based on ISO 3046-1 standard reference conditions of 25° C (77° F) and 100 kPa (29.61 in Hg), including one engine-driven lube oil pump, with 5% tolerance and LCV = 42 700 kJ/kg (18,358 Btu/lb).
- Dual Fuel (DF) engines: Specific fuel consumption (g/kWh) for liquid fuel; heat rate MJ/kWh for gaseous fuel.
- Generator efficiency: Efficiency of 97.0% (96.0% for complete CM20 and CM25 model range, and for 6CM32, 8CM32, 9CM32) based on power factor 0.8 with medium voltage class generator; actual efficiency will depend on generator selection.
- Crude oil operation only at continuous power generation.

## CM Pump Application

### Emissions according to WB2

CM Model	Fuel Type	Output Range		Speed	Minimum Speed	Bore x Stroke		Fuel Efficiency		Crude Oil/ Heavy Fuel Operation at COP
		kW	hp	rpm	rpm	mm	in	g/kWh	MJ/kWh	
6CM20C	Diesel	1140	<b>1529</b>	1000	300	200 x 300	<b>7.9 x 11.8</b>	190	8.11	x
8CM20C	Diesel	1520	<b>2038</b>	1000	300	200 x 300	<b>7.9 x 11.8</b>	190	8.11	x
9CM20C	Diesel	1710	<b>2293</b>	1000	300	200 x 300	<b>7.9 x 11.8</b>	190	8.11	x
6CM25C	Diesel	1800	<b>2414</b>	750	250	250 x 400	<b>9.8 x 15.7</b>	185	7.90	x
8CM25C	Diesel	2400	<b>3218</b>	750	240	250 x 400	<b>9.8 x 15.7</b>	185	7.90	x
9CM25C	Diesel	2700	<b>3621</b>	750	250	250 x 400	<b>9.8 x 15.7</b>	185	7.90	x
6CM32C	Diesel	2700	<b>3621</b>	600	360	320 x 480	<b>12.6 x 18.9</b>	185	7.90	x
8CM32C	Diesel	3600	<b>4828</b>	600	360	320 x 480	<b>12.6 x 18.9</b>	185	7.90	x
9CM32C	Diesel	4050	<b>5431</b>	600	360	320 x 480	<b>12.6 x 18.9</b>	185	7.90	x

### Gas Engines:

G12CM34	Natural gas	4575	<b>6135</b>	750	450	340 x 420	<b>13.4 x 16.5</b>	N/A	7.92	
G16CM34	Natural gas	6100	<b>8180</b>	750	450	340 x 420	<b>13.4 x 16.5</b>	N/A	7.94	

\*Heat rate (MJ/kWh) for gaseous fuel.

#### NOTES:

- Ratings: Continuous power based on ISO 3046-1 standard reference conditions.
- Power output: May require adjustment for values other than ISO 3046-1 standard reference conditions.
- Fuel as specified per ISO 8217. Limiting Caterpillar specification for fuel is VD8738 for crude oil operation at continuous power operation (COP).
- Fuel consumption: Based on ISO 3046-1 standard reference conditions of 25° C (77° F) and 100 kPa (29.61 in Hg), including one engine-driven lube oil pump, with 5% tolerance and LCV = 42 700 kJ/kg (18,358 Btu/lb).
- Dual Fuel (DF) engines: Specific fuel consumption (g/kWh) for liquid fuel; heat rate MJ/kWh for gaseous fuel.
- Generator efficiency: Efficiency of 97.0% (96.0% for complete CM20 and CM25 model range, and for 6CM32, 8CM32, 9CM32) based on power factor 0.8 with medium voltage class generator; actual efficiency will depend on generator selection.
- Crude oil operation only at continuous power generation.

## Engines

### Cat Oil and Gas Engines

- Offshore Power Module Ratings
- Land Rig Power Module Ratings

## Cat Oil and Gas Engines

### Offshore Power Module Ratings

Model	L with Base		W of Base		H with Base		Approximate Weight with Base	
	m	ft	mm	in	mm	in	kg	lb
3508B	4.03	13'3"	1784	70	2048	80	12 475	27,503
3512B	4.84	15'11"	1988	78	2207	86	14 975	33,014
3512C	5.45	17'11"	1827	71	2315	91	14 975	33,300
3516B	6.09	20'6"	2474	84	2214	87	18 000	41,400

### Land Rig Power Module Ratings

Model	L Bases Available*		W of Base		Radiator Height with Base		Approximate Weight with Base	
	m	ft	mm	in	mm	in	kg	lb
3508	7.85	25'9"	2385	94	2779	109.0	14 443	31,843
3508B	4.99	16'4"	2319	91	2596	102.0	15 352	33,846
3512	7.85	25'9"	2385	94	2936	116.0	15 714	34,644
3512B	6.05	19'10"	2318	91	2659	104.7	14 000	30,864
3512C	6.05	19'10"	2318	91	2659	104.7	14 453	31,864
3516	7.85	25'9"	2385	94	2497	98.3	18 340	40,433
3516B	7.85	25'9"	2385	94	2520	99.0	18 810	41,469

\*9.37 m (30'9") and 12.4 m (40'9") bases also available for all models except 3508B.

**Cat Oil and Gas Engines**

**Electric Drive Engine Ratings for SCR and DC Powered Rigs**

Model	No. Cyl.	60 Hz								50 Hz					
		720 rpm		900 rpm		1200 rpm		1800 rpm		750 rpm		1000 rpm		1500 rpm	
		bkW	bhp	bkW	bhp	bkW	bhp	bkW	bhp	bkW	bhp	bkW	bhp	bkW	bhp
<b>3508</b>	V-8	—	—	—	—	641	<b>860</b>	—	—	—	—	—	—	—	—
<b>3508B</b>	V-8	—	—	—	—	682	<b>915</b>	—	—	—	—	—	—	880	<b>1180</b>
<b>3508C</b>	V-8	—	—	—	—	682	<b>915</b>	—	—	—	—	—	—	—	—
<b>3512</b>	V-12	—	—	—	—	708-1070	<b>950-1435</b>	—	—	—	—	830-890	<b>1113-1194</b>	1090	<b>1462</b>
<b>3512B</b>		—	—	—	—	1102	<b>1478</b>	—	—	—	—	933	<b>1251</b>	1257-1310	<b>1686-1757</b>
<b>3512C</b>	V-12	—	—	—	—	1102	<b>1478</b>	—	—	—	—	—	—	—	—
<b>3512C HD</b>	V-12	—	—	—	—	1305	<b>1750</b>	—	—	—	—	—	—	1310	<b>1757</b>
<b>3516</b>	V-16	—	—	—	—	1345	<b>1804</b>	—	—	—	—	1200	<b>1609</b>	—	—
<b>3516B</b>	V-16	—	—	—	—	1383-1717	<b>1855-2303</b>	—	—	—	—	—	—	—	—
<b>3516B HD</b>	V-16	—	—	—	—	1603	<b>2150</b>	—	—	—	—	—	—	—	—
<b>3516C HD</b>	V-16	—	—	—	—	1383	<b>1855</b>	—	—	—	—	—	—	—	—
<b>3516C HD</b>	V-16	—	—	—	—	1603	<b>2150</b>	—	—	—	—	—	—	—	—
<b>C175-16</b>	V-16	—	—	—	—	1930	<b>2586</b>	—	—	—	—	—	—	—	—

4

bhp — Brake horsepower  
 bkW — Brake kilowatts

Requires Separate Circuit Aftercooling (SCAC), without fan power, when emissions compliant.

**NOTE:** For specific emission standards per model and rating, please see pages 4-21 through 4-22.

## Engines

### Cat Oil and Gas Engines

- Mechanical Drill Rig Ratings
- Fracturing/Acidizing/Cementing Ratings

## Cat Oil and Gas Engines

### Mechanical Drill Rig Ratings

Model	Pumping and Drilling Ratings (B Level)			
	No. Cyl.	rpm	bkW	bhp
<b>C15 ACERT</b>	I-6	1800-2100	354	<b>475</b>
<b>C18 ACERT</b>	I-6	2100	447	<b>600</b>
<b>C27 ACERT</b>	V-12	1800-2100	652	<b>875</b>
<b>C32 ACERT</b>	V-12	1800-2100	708	<b>950</b>
<b>3508</b>	V-8	1200	567	<b>760</b>
<b>3508B</b>	V-8	1200	671	<b>900</b>
<b>3508B</b>	V-8	1200	567	<b>760</b>
<b>3512</b>	V-12	1200	932	<b>1250</b>
<b>3512C HD</b>	V-12	1200	1100	<b>1475</b>

bhp — Brake horsepower  
 bkW — Brake kilowatts

### Fracturing/Acidizing/Cementing Ratings

Dry Manifolds (E Level)			
Model	bkW	bhp	rpm
<b>C11 ACERT</b>	336	<b>450</b>	2100
<b>C13 ACERT</b>	388	<b>520</b>	2100
<b>C15 ACERT</b>	444	<b>595</b>	2100
<b>C18 ACERT</b>	597	<b>800</b>	2100
<b>C32 ACERT</b>	913-1119	<b>1225-1500</b>	2100
<b>3512B</b>	1491	<b>2000</b>	1900
<b>3512B</b>	1603	<b>2150</b>	1900
<b>3512B</b>	1678	<b>2250</b>	1900
<b>3512C HD</b>	1603	<b>2150</b>	1900
<b>3512C HD</b>	1678	<b>2250</b>	1900
<b>3512C HD</b>	1752	<b>2350</b>	1900
<b>3512C HD</b>	1864	<b>2500</b>	1900
<b>3512E</b>	1678	<b>2250</b>	1800
<b>3512E</b>	1864	<b>2500</b>	1800
<b>3516C HD</b>	2237	<b>3000</b>	1900
<b>3516C HD</b>	2349	<b>3150</b>	1900
<b>3516C HD</b>	2461	<b>3300</b>	1900

Water Cooled Manifolds (E Level)			
Model	bkW	bhp	rpm
<b>C32 ACERT</b>	913	<b>1225</b>	2100

bhp — Brake horsepower  
 bkW — Brake kilowatts

E Rating Level — fracturing.

#### Rating Definitions:

The horsepower and speed capability of the engine which can be used to power high pressure well servicing equipment.

**NOTE:** For a transmission match, consult your transmission supplier.

- Locomotive Traction Engine Ratings
- Auxiliary Electric (Head End) Power Engine Ratings
- Maintenance of Way Engine Ratings

## Cat Railway Power

### Locomotive Traction Engine Ratings

Model	Low Rating		High Rating		Rated Speed	Emissions
	bkW	bhp	bkW	bhp	rpm	Standards
<b>C9.3 ACERT</b>	205	<b>275</b>	280	<b>375</b>	1800-2200	U.S. EPA Tier 4***, EU Stage IIIB
<b>C13 ACERT</b>	287	<b>385</b>	388	<b>520</b>	1800-2100	U.S. EPA Tier 4***, EU Stage IIIB
<b>C15 ACERT</b>	328	<b>440</b>	444	<b>595</b>	1800-2100	U.S. EPA Tier 4***, EU Stage IIIB
<b>C18 ACERT</b>	429	<b>575</b>	600	<b>805</b>	1800-2100	U.S. EPA Tier 4***, EU Stage IIIB
<b>C27 ACERT</b>	597	<b>800</b>	858	<b>1150</b>	1800-2100	U.S. EPA Tier 2, Tier 4***, EU Stage IIIB
<b>C32 ACERT</b>	708	<b>950</b>	1007	<b>1350</b>	1800-2100	U.S. EPA Tier 2, Tier 4***, EU Stage IIIB
<b>3508</b>	503	<b>675</b>	1000	<b>1341</b>	1300-1800	U.S. EPA Tier 2, UIC2, EU Stage IIIA
<b>3512*</b>	746	<b>1000</b>	1800	<b>2414</b>	1300-1800	U.S. EPA Tier 3, UIC2, EU Stage IIIA, EU Stage IIIB
<b>3516</b>	1200	<b>1600</b>	2240	<b>3004</b>	1300-1800	U.S. EPA Tier 2, UIC2, EU Stage IIIB
<b>G3516B**</b>	895	<b>1200</b>	1104	<b>1480</b>	1500	—
<b>C175-16 ACERT*</b>	2800	<b>3755</b>	3000	<b>4023</b>	1800	EU Stage IIIA, IIIB

\*For EU Stage IIIB Equivalent availability contact your Cat dealer.

\*\*For gas engine product offerings contact your Cat dealer.

\*\*\*Meets U.S. EPA Tier 4 Interim Equivalent or U.S. EPA Tier 4 Final emission standards.

### Auxiliary Electric (Head End) Power Engine Ratings

Model	Rating	Power	Emissions
	Hz	ekW	Standards
<b>C15 ACERT</b>	50	292	EU Stage II
<b>C15 ACERT</b>	50	328	EU Stage II
<b>C15 ACERT</b>	50	364	EU Stage II
<b>C15 ACERT</b>	50	400	EU Stage II
<b>C15 ACERT</b>	60	320	U.S. EPA Tier 3
<b>C15 ACERT</b>	60	365	U.S. EPA Tier 3
<b>C15 ACERT</b>	60	410	U.S. EPA Tier 3
<b>C15 ACERT</b>	60	455	U.S. EPA Tier 2 and Tier 4*
<b>C18 ACERT</b>	50	400	EU Stage II
<b>C18 ACERT</b>	50	436	EU Stage II
<b>C18 ACERT</b>	50	508	EU Stage II
<b>C18 ACERT</b>	50	573	EU Stage II
<b>C18 ACERT</b>	60	500	U.S. EPA Tier 2
<b>C18 ACERT</b>	60	545	U.S. EPA Tier 2
<b>C27 ACERT</b>	60	590	U.S. EPA Tier 2
<b>C27 ACERT</b>	60	635	U.S. EPA Tier 2
<b>C27 ACERT</b>	60	680	U.S. EPA Tier 2
<b>C27 ACERT</b>	60	725	U.S. EPA Tier 2 and Tier 4*

\*Meets U.S. EPA Tier 4 Interim Equivalent or U.S. EPA Tier 4 Final emission standards.

All 60 Hz ratings are U.S. EPA emission certified (non-road mobile standards).

All 50 Hz ratings are EU emission certified (non-road mobile standards).

### Maintenance of Way Engine Ratings

Please refer to Cat Railway Engine Ratings Guide for all Cat Railway Power Maintenance of Way Engine applications.



# FOREST PRODUCTS

## CONTENTS

### HARVESTING

Track Harvesters	
Sustainability . . . . .	5-3
Features . . . . .	5-3
Specifications . . . . .	5-5
Dimensions . . . . .	5-7
Shipping Dimensions . . . . .	5-8
Range Diagrams . . . . .	5-10
Track Feller Bunchers	
Features . . . . .	5-13
Specifications . . . . .	5-14
Shipping Dimensions . . . . .	5-16
Range Diagrams . . . . .	5-19
Wheel Feller Bunchers	
Features . . . . .	5-21
Specifications . . . . .	5-21
Dimensions . . . . .	5-22
Felling Heads	
Specifications . . . . .	5-24
SATCO Directional Felling Heads	
Features . . . . .	5-25
Specifications . . . . .	5-26
Harvester Heads	
Application . . . . .	5-27
Features . . . . .	5-27
Specifications . . . . .	5-27
Dimensions . . . . .	5-28
SATCO Processing Heads	
Features . . . . .	5-29
Specifications . . . . .	5-30

### WOOD EXTRACTION

Wheel Skidders	
Features . . . . .	5-37
Specifications . . . . .	5-38
Dimensions . . . . .	5-41
Lift Charts . . . . .	5-42
Grapple Dimensions . . . . .	5-44
Track Skidders	
Introduction . . . . .	5-45
Features . . . . .	5-45
Specifications . . . . .	5-46
Shoe Selection and Ground Pressure . . . . .	5-47
Winch Specifications . . . . .	5-47
Dimensions . . . . .	5-48
Drawbar Pull . . . . .	5-50
Grapple Specifications . . . . .	5-51
Forwarders	
Sustainability . . . . .	5-53
Features . . . . .	5-53
Specifications . . . . .	5-53
Dimensions . . . . .	5-55
Lift Capacities . . . . .	5-56

### PROCESSING/LOADING

Forest Machines	
Introduction . . . . .	5-57
Features . . . . .	5-57
Specifications . . . . .	5-60
Working Ranges . . . . .	5-66
Shipping Dimensions . . . . .	5-74
Trailer Mount Knuckleboom Loaders	
Features . . . . .	5-84
Specifications . . . . .	5-84
Dimensions . . . . .	5-85
Lift and Range Diagrams . . . . .	5-86



**MILLYARDS**

Stationary Mount Knuckleboom Loaders	
Features . . . . .	5-89
Specifications . . . . .	5-89
Dimensions . . . . .	5-90
Lift and Range Diagrams . . . . .	5-91
Wheel Loaders	
Forestry Features . . . . .	5-95
Forestry Specifications . . . . .	5-95
Load Capacity Curves . . . . .	5-96

**SITE PREP**

586C Site Prep Tractor	
Features . . . . .	5-120
Specifications . . . . .	5-121
Dimensions . . . . .	5-122

**WORKTOOLS**

Grapples for Heel Boom Log Loaders	
Features . . . . .	5-127
Dimensions . . . . .	5-128
Logging Forks	
Features . . . . .	5-129
Specifications . . . . .	5-129
Couplers	
Features . . . . .	5-134
Buckets and Thumbs	
Features . . . . .	5-134
Woodchip Dozers and Scoops	
Features . . . . .	5-135
Specifications . . . . .	5-135
Rakes	
Features . . . . .	5-136

**TABLES**

Log Volume Tables . . . . .	5-137
Weights of Commercially Important Woods . . . . .	5-139
Estimating Number of Trees . . . . .	5-142
Comparison of Log Rules . . . . .	5-142
Measurement Definitions . . . . .	5-143
Cubic Feet of Solid Wood per Cord . . . . .	5-143
Rule of Thumb Conversions . . . . .	5-143

**Sustainability:**

- **Major structures and components** are built to be rebuilt, reducing waste and replacement costs.
- **ACERT™ Technology** reduces engine emissions at point of combustion with less moving parts for lower operating costs.

**501 HD — Track Harvester Features:**

- **Cat® C6.6 ACERT Technology** provides excellent fuel economy and the engines meet U.S. EPA Tier 3/ EU Stage IIIA/Japan 2006 (Tier 3) equivalent emission standards. Flex engines are available for HRC regions.
- **Optional 8.2 m (27 ft) telescopic boom** provides additional reach.
- **Unique front entry cab** allows for easy entry and exit.
- **Tilt cab** provides easy service.
- **Proven x-design carbody and large track system** provide strength and durability.
- **Large heavy-duty swing bearing and swing torque** enhance productivity.
- **Exceptional operator visibility.**
- **IQAN computer based control system** provides precise control of machine and attachment functions.

**521B/522B —****Zero Tail Swing Track Harvester Features:**

- **Cat C9 ACERT Tier 3/Stage IIIA/Japan 2006 (Tier 3) equivalent high torque engine** provides excellent power, fuel economy, serviceability and durability.
- **The most robust tilt mechanism** in the industry, the tilting model (522B) has a patented 3-cylinder tilt mechanism with simultaneous tilting forward and side-to-side.
- **Proven rugged undercarriage** designed for the toughest harvesting conditions ranging from wet bottomlands to steep rocky slopes.
- **Hydraulically actuated clam-shell service door** provides full access and reduces maintenance down time.
- **Comfortable, purpose built forestry cab** with heavy duty guarding meets FOPS/ROPS/OPS or OR/OSHA requirements.
- **Flexaire fan (standard)** allows the cooling fan to purge debris from the radiator area minimizing cooling system maintenance.
- **Hydraulic system** is easily adaptable to both harvesting and directional felling heads.
- **IQAN display** allows the operator to continuously monitor the machine and get early warning for potential problems.
- **Ergonomically located pedals with side-by-side foot rests** provide maximum operator comfort when the machine is traveling.
- **Serviceability** has been improved with vertical mounted main hydraulic control valves and increased hood enclosure area. A larger standard fuel tank allows more run time between re-fueling stops.

### 541 Series 2/552 Series 2 — Full Tail Swing Track Harvester Features:

- **Cat C9 ACERT Tier 3/Stage IIIA/Japan 2006 (Tier 3) equivalent high torque engine** provides excellent power, fuel economy, serviceability and durability.
- **The most robust tilt mechanism** in the industry, the tilting model (552 Series 2) has a patented 3-cylinder tilt mechanism with simultaneous tilting forward and side-to-side.
- **Proven rugged undercarriage** designed for the toughest harvesting conditions ranging from wet bottomlands to steep rocky slopes.
- **Hydraulically actuated dual service door** provides engine/hydraulic access direct from the cab.
- **Walk through service access** minimizes service time and down time costs.
- **Comfortable, purpose built forestry cab** with heavy duty guarding meets FOPS/ROPS/OPS and OR/OSHA requirements.
- **Flexaire fan (standard)** allows the cooling fan to purge debris from the radiator area minimizing cooling system maintenance.
- **Hydraulic system** is easily adaptable to both harvesting and directional felling heads.
- **IQAN display** allows the operator to continuously monitor the machine and get early warning for potential problems.
- **Ergonomically located pedals with side-by-side foot rests** provide maximum operator comfort when the machine is traveling.

**Track Harvesters**

<b>MODEL</b>	<b>501 HD</b>	
Gross Power (ISO 14396)	122 kW	163 hp
Operating Weight (without attachment)	18 000 kg	40,000 lb
Engine Model	<b>C6.6 ACERT</b>	
Emission Standards	<b>Tier 3/Stage IIIA/Japan 2006 (Tier 3) equivalent</b>	
Tractive Effort	19 686 kg	43,400 lb
Undercarriage:	<b>D5</b>	
Size		
Pitch	190.5 mm	7.5"
Maximum Reach (with head)	8200 mm	27'0"
Minimum Reach (with head)	3658 mm	12'0"
Fuel Capacity	378 L	100 U.S. gal
Hydraulic System	545 bar	5000 psi
Hydraulic Oil Flow	307 L/min	81 gpm
Hydraulic Oil Reservoir	230 L	60 U.S. gal
General Dimensions:		
Height (with standard pads)	3429 mm	11'3"
Width (with 610 mm/24" pads)	2845 mm	9'4"

5

**ZTS (Zero Tail Swing)**

<b>MODEL</b>	<b>521B</b>		<b>522B</b>	
Gross Power (ISO 14396) @ 1800 RPM	226 kW	<b>303 hp</b>	226 kW	<b>303 hp</b>
Operating Weight (without head)	26 966 kg	<b>59,450 lb</b>	31 993 kg	<b>70,532 lb</b>
Engine Model	<b>C9 ACERT</b>		<b>C9 ACERT</b>	
Emission Standards	<b>Tier 3/Stage IIIA/ Japan 2006 (Tier 3) equivalent</b>		<b>Tier 3/Stage IIIA/ Japan 2006 (Tier 3) equivalent</b>	
Displacement	8.8 L	<b>537 in<sup>3</sup></b>	8.8 L	<b>537 in<sup>3</sup></b>
Tractive Effort — Standard	314 kN	<b>70,500 lbf</b>	336 kN	<b>75,500 lbf</b>
— Optional	—		378 kN	<b>85,000 lbf</b>
Undercarriage:	<b>330 EX</b>		<b>330 EX</b>	
Size				
Pitch	215.9 mm	<b>8.5"</b>	215.9 mm	<b>8.5"</b>
Track Gauge	2591 mm	<b>102"</b>	2591-2870 mm	<b>102-113"</b>
Track Length	4855 mm	<b>191"</b>	4855 mm	<b>191"</b>
Swing Torque	87.5 kN·m	<b>64,500 lb-ft</b>	87.5 kN·m	<b>64,500 lb-ft</b>
Swing Speed	<b>6.8 RPM</b>		<b>6.8 RPM</b>	
Maximum Reach (with head)	9.9 m	<b>32'6"</b>	9.9 m	<b>32'6"</b>
Bare Pin Lift @ Maximum Reach (without head)*	4000 kg @ 9.8 m	<b>8800 lb @ 32'6"</b>	4000 kg @ 9.8 m	<b>8800 lb @ 32'6"</b>
Fuel Capacity	856 L	<b>226 U.S. gal</b>	856 L	<b>226 U.S. gal</b>
Hydraulic System:	<b>Electric</b>		<b>Electric</b>	
Oil Fill Pump	<b>Electric</b>		<b>Electric</b>	
Variable Displacement Pumps:				
Travel and Tilt Functions (552 only)	416 L	<b>110 gpm</b>	416 L	<b>110 gpm</b>
Boom and Implement Functions	416 L	<b>110 gpm</b>	416 L	<b>110 gpm</b>
General Dimensions:				
Ground Clearance	889 mm	<b>35"</b>	889 mm	<b>35"</b>
Width (with 610 mm/24" Track Shoe)	3200 mm	<b>126"</b>	3200 mm	<b>126"</b>
Adjustable to	—		3480 mm	<b>137"</b>
Height (to top of cab with standard skylight)	3761 mm	<b>148"</b>	4011 mm	<b>158"</b>
Tail Swing (with Counterweight)	1929 mm	<b>6'4"</b>	1929 mm	<b>6'4"</b>

\*Lift over front of tracks.

### FTS (Full Tail Swing) MODEL

	541 Series 2		552 Series 2	
Gross Power (ISO 14396) @ 1800 RPM	226 kW	<b>303 hp</b>	226 kW	<b>303 hp</b>
Operating Weight (without head):				
Standard Harvester Linkage	31 135 kg	<b>68,640 lb</b>	36 124 kg	<b>79,639 lb</b>
Long Harvester Linkage	31 147 kg	<b>68,667 lb</b>	36 151 kg	<b>79,700 lb</b>
Engine Model	<b>C9 ACERT</b>		<b>C9 ACERT</b>	
Emission Standards	<b>Tier 3/Stage IIIA/ Japan 2006 (Tier 3) equivalent</b>		<b>Tier 3/Stage IIIA/ Japan 2006 (Tier 3) equivalent</b>	
Displacement	8.8 L	<b>537 in<sup>3</sup></b>	8.8 L	<b>537 in<sup>3</sup></b>
Tractive Effort	336 kN	<b>75,500 lbf</b>	463 kN	<b>104,000 lbf</b>
Undercarriage:				
Size	<b>330 EX</b>		<b>345 EX</b>	
Pitch	215.9 mm	<b>8.5"</b>	215.9 mm	<b>8.5"</b>
Track Gauge	2591-2870 mm	<b>102-113"</b>	2591-2870 mm	<b>102-113"</b>
Track Length	4893 mm	<b>192.6"</b>	4903 mm	<b>193"</b>
Swing Torque	97.6 kN-m	<b>72,000 lb-ft</b>	97.6 kN-m	<b>72,000 lb-ft</b>
Swing Speed	<b>6.8 RPM</b>		<b>6.8 RPM</b>	
Maximum Reach (long linkage with head)	10.7 m	<b>35'0"</b>	10.7 m	<b>35'0"</b>
Bare Pin Lift @ Maximum Reach (without head):*				
Standard Harvester Linkage	6400 kg @ 8.2 m	<b>14,100 lb @ 27'0"</b>	7700 kg @ 8.2 m	<b>16,900 lb @ 27'0"</b>
Long Harvester Linkage	4300 kg @ 10.7 m	<b>9480 lb @ 35'0"</b>	5700 kg @ 10.7 m	<b>12,500 lb @ 35'0"</b>
Fuel Capacity	1181 L	<b>312 U.S. gal</b>	1181 L	<b>312 U.S. gal</b>
Hydraulic System:				
Oil Fill Pump	<b>Electric</b>		<b>Electric</b>	
Variable Displacement Pumps:				
Travel and Implement Functions (x2)	416 L	<b>110 gpm</b>	416 L	<b>110 gpm</b>
General Dimensions:				
Ground Clearance	889 mm	<b>35"</b>	889 mm	<b>35"</b>
Width (with 710 mm/28" Track Shoe)	3327 mm	<b>131"</b>	3327 mm	<b>131"</b>
Adjustable to	3607 mm	<b>142"</b>	3607 mm	<b>142"</b>
Height (to top of cab with standard skylight)	3556 mm	<b>140"</b>	3962 mm	<b>156"</b>
Tail Swing	2743 mm	<b>9'0"</b>	2743 mm	<b>9'0"</b>

\*Lift over front of tracks.

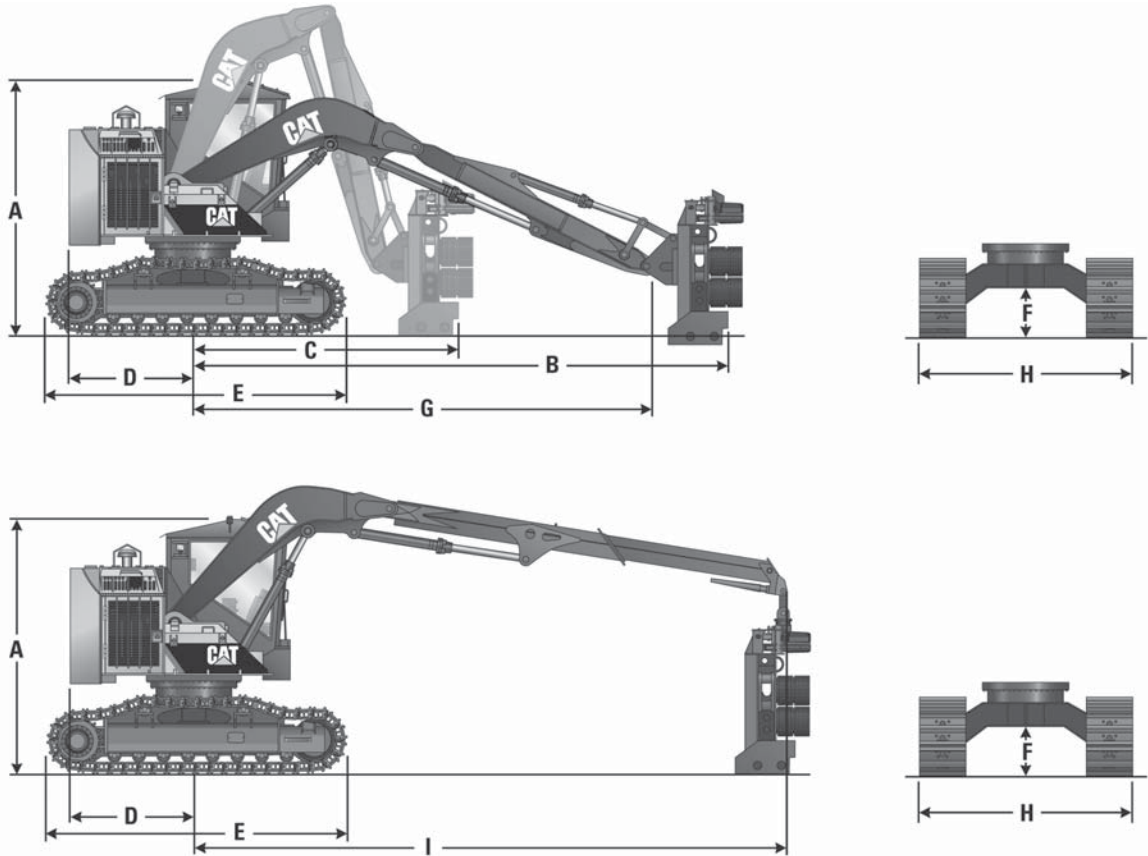

**MODEL**

**501 HD**

<b>A</b> Height with Standard Pads	3429 mm	11'3"
<b>B</b> Maximum Reach with Prentice PF-48 Processor	7087 mm	23'3"
<b>C</b> Minimum Reach with Prentice PF-48 Processor	3658 mm	12'0"
<b>D</b> Swing Center to Rear of Counterweight	1645 mm	64.75"
<b>E</b> Undercarriage Length	3962 mm	13'0"
<b>F</b> Ground Clearance	660 mm	26"
<b>G</b> Reach to Stick Boom Pin with Standard Boom	6045 mm	19'10"
<b>H</b> Width – with 610 mm (24 in) Pads	2845 mm	9'4"
<b>I</b> Reach to Stick Boom Pin with Telescopic Boom Extended	7930 mm	26'0"

These illustrations and values are ESTIMATED for TRUCK SHIPMENT ONLY FROM THE FACTORY. These are subject to change based on attachments, configurations, add-ons, etc.

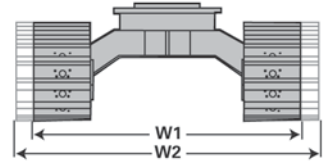

### 521B (Non-Tilter) ZTS Track Harvesters

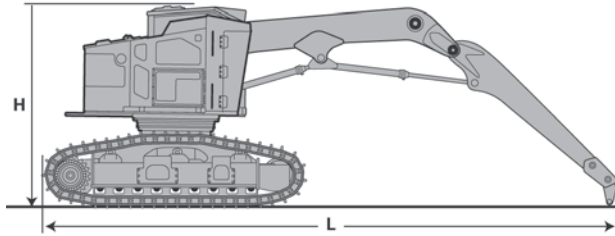

### 522B (Tilter) ZTS Track Harvesters

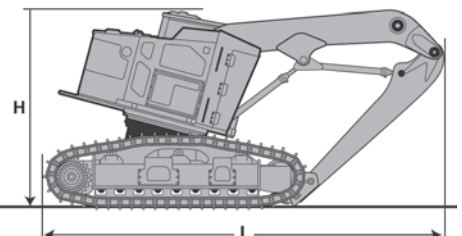

### ZTS Track Harvesters Shipping Dimensions

MODEL	Length		Height*		Width 1+		Width 2++		Weight	
<b>521B</b>	12 151 mm	<b>478"</b>	3761 mm	<b>148"</b>	3200 mm	<b>126"</b>	—		26 966 kg	<b>59,450 lb</b>
<b>522B**</b>	8222 mm	<b>324"</b>	4011 mm	<b>158"</b>	3200 mm	<b>126"</b>	3480 mm	<b>137"</b>	31 993 kg	<b>70,532 lb</b>

Length, Height and Width 1 assume 610 mm (24") Single Grouser shoes.

\*Height to the highest point on machine.

\*\*Boom tucked.

+Width 1 is minimum width with 610 mm (24") Single Grouser shoes.

++Width 2 is maximum width when undercarriage is set wide.

These illustrations and values are ESTIMATED for TRUCK SHIPMENT ONLY FROM THE FACTORY. These are subject to change based on attachments, configurations, add-ons, etc.

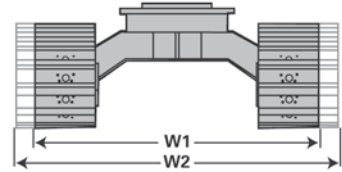

**541 Series 2 (Non-Tilter) FTS Track Harvesters**

**552 Series 2 (Tilter) FTS Track Harvesters**

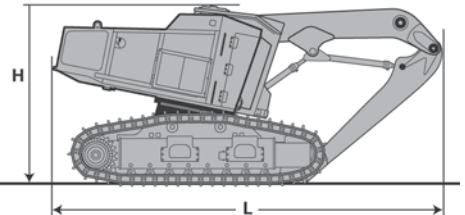
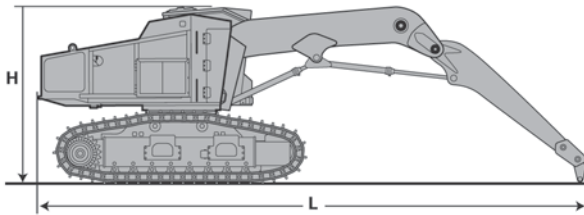

**FTS Track Harvesters Shipping Dimensions**

MODEL	Length		Height*		Width 1+		Width 2++		Weight	
<b>541 Series 2</b>										
Standard Harvester Linkage	11 074 mm	<b>436"</b>	3556 mm	<b>140"</b>	3327 mm	<b>131"</b>	3607 mm	<b>142"</b>	31 135 kg	<b>68,640 lb</b>
Long Harvester Linkage	13 614 mm	<b>536"</b>	3556 mm	<b>140"</b>	3327 mm	<b>131"</b>	3607 mm	<b>142"</b>	31 147 kg	<b>68,667 lb</b>
<b>552 Series 2**</b>										
Standard Harvester Linkage	11 024 mm	<b>434"</b>	3962 mm	<b>156"</b>	3327 mm	<b>131"</b>	3607 mm	<b>142"</b>	36 124 kg	<b>79,639 lb</b>
Long Harvester Linkage	7010 mm	<b>276"</b>	3962 mm	<b>156"</b>	3327 mm	<b>131"</b>	3607 mm	<b>142"</b>	36 151 kg	<b>79,700 lb</b>

Length, Height and Width assume 711 mm (28") Single Grouser shoes.

\*Height to the highest point on machine.

\*\*Boom tucked.

+Width 1 is minimum width with 711 mm (28") Single Grouser shoes.

++Width 2 is maximum width when undercarriage is set wide.



**Lift Range Information —  
501HD Fixed Head Boom Sweep**

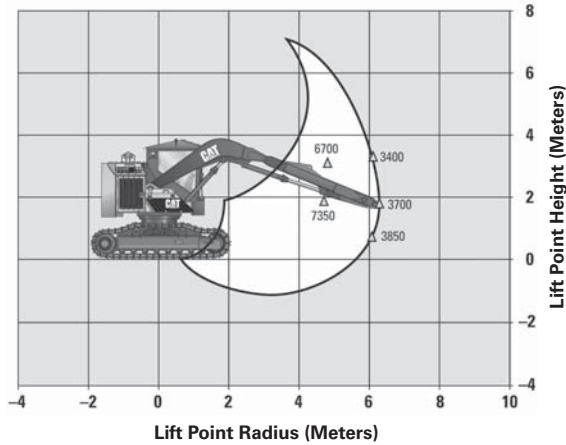

— SWEEP    Δ Lift (kg)

**Lift Range Information —  
501HD Telescopic Boom Sweep**

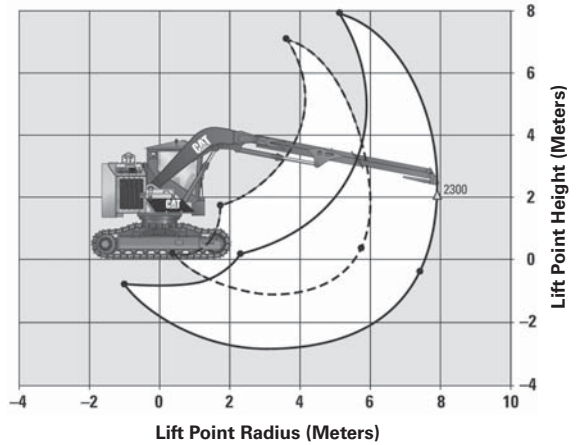

— ARM EXTENDED    - - - - ARM RETRACTED    Δ Lift (kg)

**Lift Range Information —  
501HD Fixed Head Boom Sweep**

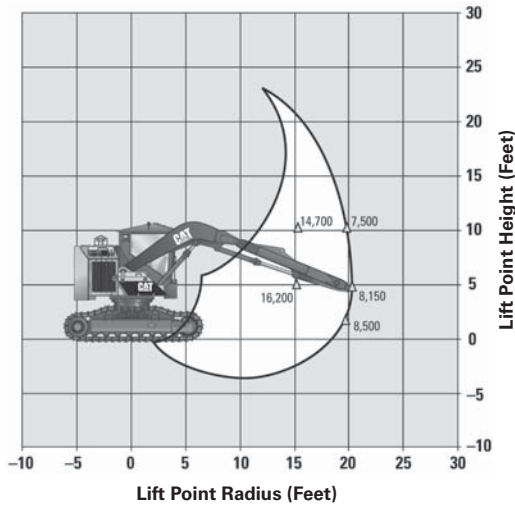

— SWEEP    Δ Lift (lb)

**Lift Range Information —  
501HD Telescopic Boom Sweep**

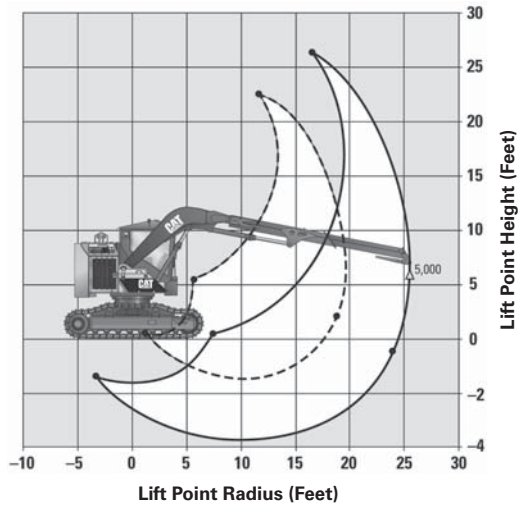

— ARM EXTENDED    - - - - ARM RETRACTED    Δ Lift (kg)

**Lift Range Information –  
Harvester Linkage  
521B/522B – ZTS**

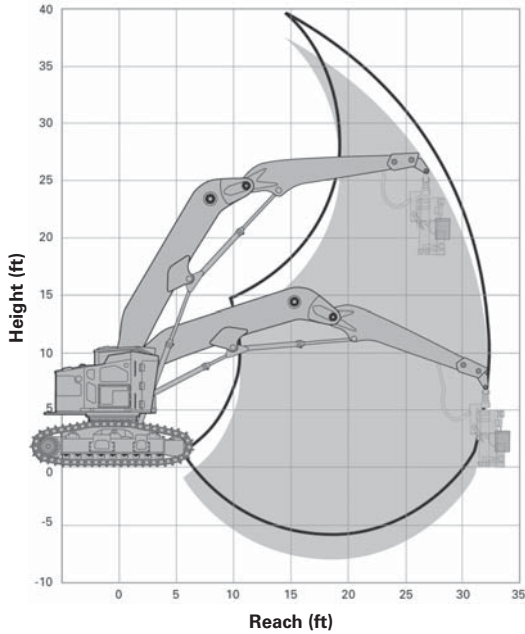

NOTE: \_\_\_\_ Line represents Tilter Model.

**Lift Over Front of Tracks**

MODEL	521B		522B	
Reach	Lift Capacity		Lift Capacity	
3.6 m (12'0")	10 500 kg	<b>23,000 lb</b>	10 500 kg	<b>23,000 lb</b>
6.1 m (20'0")	7700 kg	<b>17,000 lb</b>	7700 kg	<b>17,000 lb</b>
9.8 m (32'2")	4000 kg	<b>8800 lb</b>	4150 kg	<b>9100 lb</b>

**Lift Over Side of Tracks**

MODEL	521B		522B	
Reach	Lift Capacity		Lift Capacity	
3.6 m (12'0")	10 500 kg	<b>23,000 lb</b>	10 500 kg	<b>23,000 lb</b>
6.1 m (20'0")	7700 kg	<b>17,000 lb</b>	7700 kg	<b>17,000 lb</b>
9.8 m (32'2")	3630 kg	<b>8000 lb</b>	4150 kg	<b>9100 lb</b>

NOTE: Lift Capacity shown without attachment.  
Additional reach and attachment weight will reduce lift capacity.

### Lift Range Information – Standard Harvester Linkage 541 Series 2/552 Series 2 – FTS

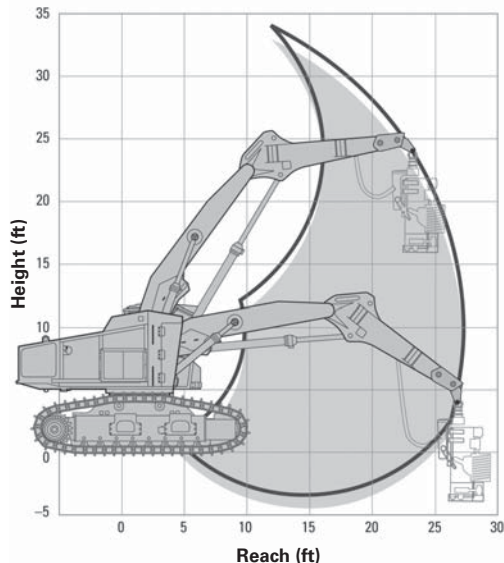

### Lift Range Information – Long Harvester Linkage 541 Series 2/552 Series 2 – FTS

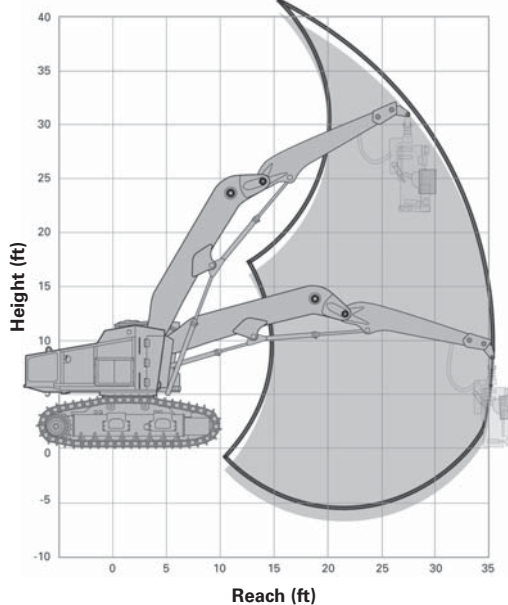

NOTE: \_\_\_\_ Line represents Tilter Model.

### Lift Over Front of Tracks

MODEL	541 Series 2	552 Series 2
<b>Reach</b>	<b>Lift Capacity</b>	<b>Lift Capacity</b>
<b>Linkage</b>	<b>Standard Harvester</b>	<b>Standard Harvester</b>
3.0 m (10'0")	20 800 kg <b>45,900 lb</b>	21 800 kg <b>48,000 lb</b>
6.1 m (20'0")	10 400 kg <b>22,900 lb</b>	10 900 kg <b>24,000 lb</b>
8.2 m (27'0")	6400 kg <b>14,100 lb</b>	7700 kg <b>16,900 lb</b>
<b>Reach</b>	<b>Lift Capacity</b>	<b>Lift Capacity</b>
<b>Linkage</b>	<b>Long Harvester</b>	<b>Long Harvester</b>
4.5 m (15'0")	9100 kg <b>20,000 lb</b>	9100 kg <b>20,000 lb</b>
7.6 m (25'0")	7100 kg <b>15,700 lb</b>	9400 kg <b>20,700 lb</b>
10.7 m (35'0")	4300 kg <b>9500 lb</b>	5700 kg <b>12,500 lb</b>

### Lift Over Side of Tracks

MODEL	541 Series 2	552 Series 2
<b>Reach</b>	<b>Lift Capacity</b>	<b>Lift Capacity</b>
<b>Linkage</b>	<b>Standard Harvester</b>	<b>Standard Harvester</b>
3.0 m (10'0")	20 800 kg <b>45,900 lb</b>	21 800 kg <b>48,000 lb</b>
6.1 m (20'0")	6600 kg <b>14,500 lb</b>	9300 kg <b>20,500 lb</b>
8.2 m (27'0")	4100 kg <b>9000 lb</b>	6000 kg <b>13,200 lb</b>
<b>Reach</b>	<b>Lift Capacity</b>	<b>Lift Capacity</b>
<b>Linkage</b>	<b>Long Harvester</b>	<b>Long Harvester</b>
4.5 m (15'0")	9100 kg <b>20,000 lb</b>	9100 kg <b>20,000 lb</b>
7.6 m (25'0")	4500 kg <b>9900 lb</b>	6500 kg <b>14,300 lb</b>
10.7 m (35'0")	2700 kg <b>5900 lb</b>	4000 kg <b>8800 lb</b>

NOTE: Lift Capacity shown without attachment.  
Additional reach and attachment weight will reduce lift capacity.

**521B/522B —****Zero Tail Swing Track Feller Buncher Features:**

- **Cat C9 ACERT Tier 3/Stage IIIA/Japan 2006 (Tier 3) equivalent high torque engine** provides excellent power, fuel economy, serviceability and durability.
- **A robust tilt mechanism**, the tilting model (522B) has a patented 3-cylinder tilt mechanism with simultaneous tilting forward and side-to-side.
- **Proven rugged undercarriage** designed for the toughest harvesting conditions ranging from wet bottomlands to steep rocky slopes.
- **Hydraulically actuated clam-shell service door** provides full service and reduces maintenance down time.
- **Comfortable, purpose built forestry cab** with heavy duty guarding meets FOPS/ROPS/OPS and OR/OSHA requirements.
- **Flexaire fan (standard)** allows the cooling fan to purge debris from the radiator area minimizing cooling system maintenance.
- **Felling heads** utilize high pressure hydraulics and proven components to meet your application requirements.
- **IQAN display** allows the operator to continuously monitor the machine and get early warning for potential problems.
- **Ergonomically located pedals with side-by-side foot rests** provide maximum operator comfort when the machine is traveling.
- **Serviceability** has been improved with vertical mounted main hydraulic control valves and increased hood enclosure area. A larger standard fuel tank allows more run time between re-fueling stops.
- **Hydraulic performance** has been enhanced with new compensator spools, improving implement and travel multi-functioning, and better hydraulic flow sharing between functions.

**541 Series 2/552 Series 2 —****Full Tail Swing Track Feller Buncher Features:**

- **Cat C9 ACERT Tier 3/Stage IIIA/Japan 2006 (Tier 3) equivalent high torque engine** provides excellent power, fuel economy, serviceability and durability.
- **The most robust tilt mechanism** in the industry, the tilting model (552 Series 2) have a patented 3-cylinder tilt mechanism with simultaneous tilting forward and side-to-side.
- **Proven rugged undercarriage** designed for the toughest harvesting conditions ranging from wet bottomlands to steep rocky slopes.
- **Hydraulically actuated dual service door** provides engine/hydraulic access direct from the cab.
- **Walk through service access** minimizes service time and down time costs.
- **Comfortable, purpose built forestry cab** with heavy duty guarding meets FOPS/ROPS/OPS and OR/OSHA requirements.
- **Optional hydraulic packages** are available for operation with an intermittent saw or a high speed disc saw.
- **Felling heads** utilize high pressure hydraulics and proven components to meet your application requirements.
- **IQAN display** allows the operator to continuously monitor the machine and get early warning for potential problems.
- **Ergonomically located pedals with side-by-side foot rests** provide maximum operator comfort when the machine is traveling.
- **Flexaire fan (standard)** allows the cooling fan to purge debris from the radiator area minimizing cooling system maintenance.
- **Hydraulic performance** has been enhanced with new compensator spools, improving implement and travel multi-functioning, and better hydraulic flow sharing between functions.

### ZTS (Zero Tail Swing) MODEL

	<b>521B</b>		<b>522B</b>	
Gross Power (ISO 14396) @ 1800 RPM	226 kW	<b>303 hp</b>	226 kW	<b>303 hp</b>
Operating Weight (without head)	27 501 kg	<b>60,629 lb</b>	32 528 kg	<b>71,711 lb</b>
Engine Model	<b>C9 ACERT</b>		<b>C9 ACERT</b>	
Emission Standards	<b>Tier 3/Stage IIIA/ Japan 2006 (Tier 3) equivalent</b>		<b>Tier 3/Stage IIIA/ Japan 2006 (Tier 3) equivalent</b>	
Displacement	8.8 L	<b>537 in<sup>3</sup></b>	8.8 L	<b>537 in<sup>3</sup></b>
Tractive Effort:				
Standard	314 kN	<b>70,500 lbf</b>	336 kN	<b>75,500 lbf</b>
Optional	—		378 kN	<b>85,000 lbf</b>
Undercarriage:				
Size	<b>330 EX</b>		<b>330 EX</b>	
Pitch	215.9 mm	<b>8.5"</b>	215.9 mm	<b>8.5"</b>
Track Gauge	2591 mm	<b>102"</b>	2591-2870 mm	<b>102-113"</b>
Track Length	4855 mm	<b>191.1"</b>	4855 mm	<b>191.1"</b>
Swing Torque	87.5 kN·m	<b>64,500 lb-ft</b>	87.5 kN·m	<b>64,500 lb-ft</b>
Swing Speed	<b>6.8 RPM</b>		<b>6.8 RPM</b>	
Maximum Reach (with head)	8.1 m	<b>26'6"</b>	8.1 m	<b>26'6"</b>
Bare Pin Lift @ Maximum Reach (without head)*	6100 kg @ 6.2 m	<b>13,500 lb @ 20'6"</b>	6100 kg @ 6.2 m	<b>13,500 lb @ 20'6"</b>
Fuel Capacity	856 L	<b>226 U.S. gal</b>	856 L	<b>226 U.S. gal</b>
Hydraulic System:				
Oil Fill Pump	<b>Electric</b>		<b>Electric</b>	
Variable Displacement Pumps:				
Travel and Tilt Functions (552 Only)	416 L	<b>110 gpm</b>	416 L	<b>110 gpm</b>
Boom and Implement Functions	416 L	<b>110 gpm</b>	416 L	<b>110 gpm</b>
Saw Pump	114 L	<b>30 gpm</b>	114 L	<b>30 gpm</b>
General Dimensions:				
Ground Clearance	889 mm	<b>35"</b>	889 mm	<b>35"</b>
Width (with 610 mm/24" Track Shoe)	3200 mm	<b>126"</b>	3200 mm	<b>126"</b>
Adjustable to	—		3480 mm	<b>137"</b>
Height (to top of cab with standard skylight)	3556 mm	<b>140"</b>	3901 mm	<b>154"</b>
Tail Swing (with Counterweight)	1929 mm	<b>6'4"</b>	1929 mm	<b>6'4"</b>

\*Lift over front of tracks.

**FTS (Full Tail Swing)  
MODEL**

	<b>541 Series 2</b>		<b>552 Series 2</b>	
Gross Power (ISO 14396) @ 1800 RPM	226 kW	<b>303 hp</b>	226 kW	<b>303 hp</b>
Operating Weight (without head):				
Standard Linkage	30 826 kg	<b>67,960 lb</b>	35 816 kg	<b>78,960 lb</b>
Long Felling Linkage	31 135 kg	<b>68,640 lb</b>	36 124 kg	<b>79,639 lb</b>
Engine Model	<b>C9 ACERT</b>		<b>C9 ACERT</b>	
Emission Standards	<b>Tier 3/Stage IIIA/ Japan 2006 (Tier 3) equivalent</b>		<b>Tier 3/Stage IIIA/ Japan 2006 (Tier 3) equivalent</b>	
Displacement	8.8 L	<b>537 in<sup>3</sup></b>	8.8 L	<b>537 in<sup>3</sup></b>
Tractive Effort	336 kN	<b>75,500 lbf</b>	463 kN	<b>104,000 lbf</b>
Undercarriage:				
Size	<b>330 EX</b>		<b>345 EX</b>	
Pitch	215.9 mm	<b>8.5"</b>	215.9 mm	<b>8.5"</b>
Track Gauge	2591-2870 mm	<b>102-113"</b>	2591-2870 mm	<b>102-113"</b>
Track Length	4893 mm	<b>192.6"</b>	4903 mm	<b>193"</b>
Swing Torque	97.6 kN·m	<b>72,000 lb-ft</b>	97.6 kN·m	<b>72,000 lb-ft</b>
Swing Speed	<b>6.8 RPM</b>		<b>6.8 RPM</b>	
Maximum Reach (with head)	8.6 m	<b>28'2"</b>	8.6 m	<b>28'2"</b>
Bare Pin Lift @ Maximum Reach (without head)*	9400 kg @ 6.6 m	<b>20,700 lb @ 21'8"</b>	9400 kg @ 6.6 m	<b>20,700 lb @ 21'8"</b>
Bare Pin Lift @ Maximum Reach (without head)**	6400 kg @ 8.2 m	<b>14,100 lb @ 27'0"</b>	7700 kg @ 8.2 m	<b>16,900 lb @ 27'0"</b>
Fuel Capacity	1181 L	<b>312 U.S. gal</b>	1181 L	<b>312 U.S. gal</b>
Hydraulic System:				
Oil Fill Pump	<b>Electric</b>		<b>Electric</b>	
Variable Displacement Pumps:				
Travel and Implement Functions (x2)	416 L	<b>110 gpm</b>	416 L	<b>110 gpm</b>
Saw Pump	114 L	<b>30 gpm</b>	114 L	<b>30 gpm</b>
General Dimensions:				
Ground Clearance	889 mm	<b>35"</b>	889 mm	<b>35"</b>
Width (with 711 mm/28" Track Shoe)	3327 mm	<b>131"</b>	3327 mm	<b>131"</b>
Adjustable to	3607 mm	<b>142"</b>	3607 mm	<b>142"</b>
Height (to top of cab with standard skylight)	3556 mm	<b>140"</b>	3962 mm	<b>156"</b>
Tail Swing	2743 mm	<b>9'0"</b>	2743 mm	<b>9'0"</b>

\*Standard linkage – Lift over front of tracks.

\*\*Long felling linkage – Lift over front of tracks.

These illustrations and values are ESTIMATED for TRUCK SHIPMENT ONLY FROM THE FACTORY. These are subject to change based on attachments, configurations, add-ons, etc.

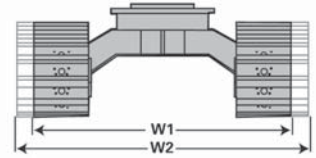

### 521B/522B ZTS Track Feller Bunchers

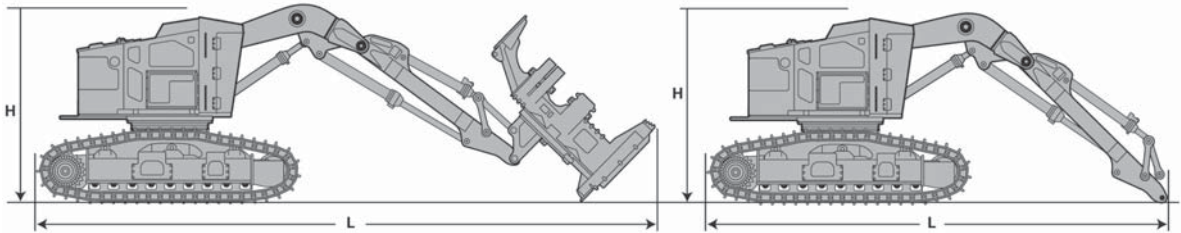

### ZTS Track Feller Bunchers Shipping Dimensions

MODEL	Length		Height**		Width 1+		Width 2++		Weight	
<b>521B</b>	8352 mm	<b>329"</b>	3550 mm	<b>140"</b>	3200 mm	<b>126"</b>	—		27 501 kg	<b>60,629 lb</b>
<b>521B*</b>	10 708 mm	<b>422"</b>	3587 mm	<b>141"</b>	3200 mm	<b>126"</b>	—		30 701 kg	<b>67,684 lb</b>
<b>522B</b>	7700 mm	<b>303"</b>	3901 mm	<b>154"</b>	3200 mm	<b>126"</b>	3480 mm	<b>137"</b>	32 528 kg	<b>71,711 lb</b>
<b>522B*</b>	10 543 mm	<b>415"</b>	3901 mm	<b>154"</b>	3200 mm	<b>126"</b>	3480 mm	<b>137"</b>	35 728 kg	<b>78,767 lb</b>

Length, Height and Width assume 610 mm (24") Single Grouser shoes.

\*With HF201B Partial Tilt Felling Head, tilted back and lifted (assumes an estimated additional head weight of 3200 kg (7054 lb)).

\*\*Height is to the highest point on machine.

+Width 1 is minimum width with 610 mm (24") Single Grouser shoes.

++Width 2 is maximum width when undercarriage is set wide.

These illustrations and values are ESTIMATED for TRUCK SHIPMENT ONLY FROM THE FACTORY.  
These are subject to change based on attachments, configurations, add-ons, etc.

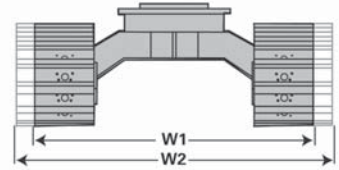

### 541 Series 2 (Non-Tilter) FTS Track Feller Bunchers Standard Linkage

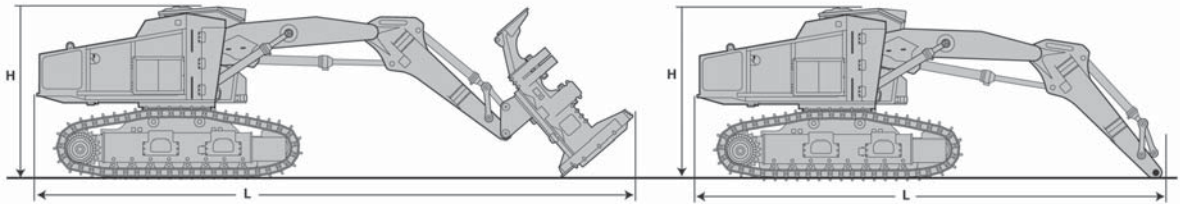

5

### 552 Series 2 (Tilter) FTS Track Feller Bunchers Standard Linkage

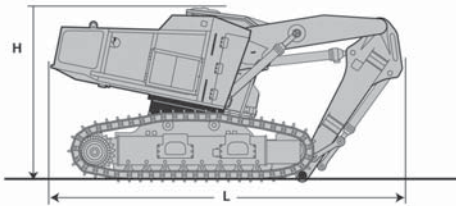

### FTS Track Feller Bunchers Shipping Dimensions

MODEL	Length		Height**		Width 1+		Width 2++		Weight	
<b>541 Series 2</b>	9423 mm	<b>371"</b>	3556 mm	<b>140"</b>	3327 mm	<b>131"</b>	3607 mm	<b>142"</b>	30 826 kg	<b>67,960 lb</b>
<b>541 Series 2*</b>	11 709 mm	<b>461"</b>	3556 mm	<b>140"</b>	3327 mm	<b>131"</b>	3607 mm	<b>142"</b>	34 609 kg	<b>76,300 lb</b>
<b>552 Series 2</b>	9423 mm	<b>371"</b>	3962 mm	<b>156"</b>	3327 mm	<b>131"</b>	3607 mm	<b>142"</b>	35 816 kg	<b>78,960 lb</b>
<b>552 Series 2*</b>	11 709 mm	<b>461"</b>	3962 mm	<b>156"</b>	3327 mm	<b>131"</b>	3607 mm	<b>142"</b>	39 600 kg	<b>87,300 lb</b>

Length, Height and Width assume 711 mm (28") Single Grouser shoes.

\*With HF221 Partial Tilt Felling Head, tilted back and lifted (assumes an estimated additional head weight of 3783 kg (8340 lb).

\*\*Height is to the highest point on machine.

+Width 1 is minimum width with 711 mm (28") Single Grouser shoes.

++Width 2 is maximum width when undercarriage is set wide.



These illustrations and values are ESTIMATED for TRUCK SHIPMENT ONLY FROM THE FACTORY. These are subject to change based on attachments, configurations, add-ons, etc.

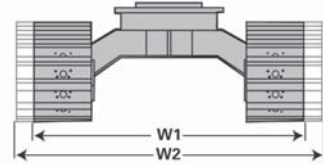

## 541 Series 2 (Non-Tilter) 552 Series 2 (Tilter) FTS Track Feller Bunchers Long Felling Linkage

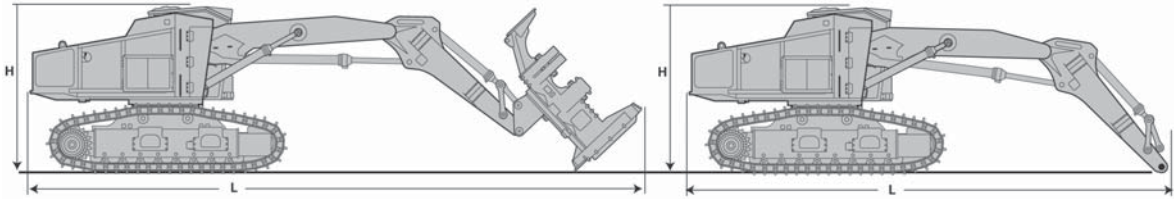

## FTS Track Feller Bunchers Shipping Dimensions

MODEL	Length		Height**		Width 1+		Width 2++		Weight	
<b>541 Series 2</b>	11 074 mm	<b>436"</b>	3556 mm	<b>140"</b>	3327 mm	<b>131"</b>	3607 mm	<b>142"</b>	31 135 kg	<b>68,640 lb</b>
<b>541 Series 2*</b>	13 360 mm	<b>526"</b>	3556 mm	<b>140"</b>	3327 mm	<b>131"</b>	3607 mm	<b>142"</b>	34 335 kg	<b>75,696 lb</b>
<b>552 Series 2</b>	11 024 mm	<b>434"</b>	3962 mm	<b>156"</b>	3327 mm	<b>131"</b>	3607 mm	<b>142"</b>	36 124 kg	<b>79,639 lb</b>
<b>552 Series 2*</b>	13 310 mm	<b>524"</b>	3962 mm	<b>156"</b>	3327 mm	<b>131"</b>	3607 mm	<b>142"</b>	39 324 kg	<b>86,694 lb</b>

Length, Height and Width assume 711 mm (28") Single Grouser shoes.

\*With HF201B Partial Tilt Felling Head, tilted back and lifted (assumes an estimated additional head weight of 3200 kg (7054 lb)).

\*\*Height is to the highest point on machine.

+Width 1 is minimum width with 711 mm (28") Single Grouser shoes.

++Width 2 is maximum width when undercarriage is set wide.

**Lift Range Information – Felling Linkage**  
**521B/522B – ZTS**

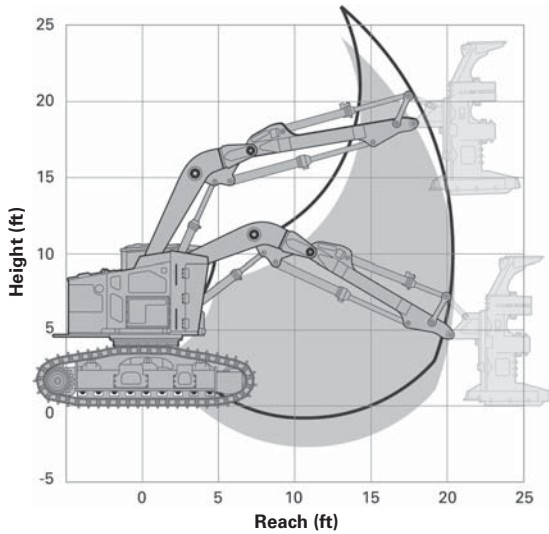

NOTE: \_\_\_\_ Line represents Tilter Model.

**Lift Over Front of Tracks**

MODEL	521B		522B	
Reach	Lift Capacity		Lift Capacity	
2.4 m (8'0")	15 450 kg	34,000 lb	16 180 kg	35,600 lb
4.5 m (15'0")	8410 kg	18,500 lb	8545 kg	18,800 lb
6.2 m (20'4")	6100 kg	13,500 lb	6100 kg	13,500 lb

**Lift Over Side of Tracks**

MODEL	521B		522B	
Reach	Lift Capacity		Lift Capacity	
2.4 m (8'0")	15 450 kg	34,000 lb	16 180 kg	35,600 lb
4.5 m (15'0")	8410 kg	18,500 lb	8545 kg	18,800 lb
6.2 m (20'4")	6100 kg	13,500 lb	6100 kg	13,500 lb

NOTE: Lift Capacity shown without attachment.  
Additional reach and attachment weight will reduce lift capacity.

### Lift Range Information — Standard Felling Linkage 541 Series 2/552 Series 2 — FTS

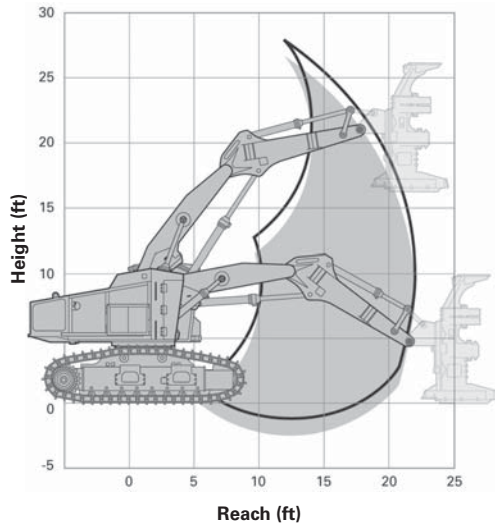

### Lift Range Information — Long Felling Linkage 541 Series 2/552 Series 2 — FTS

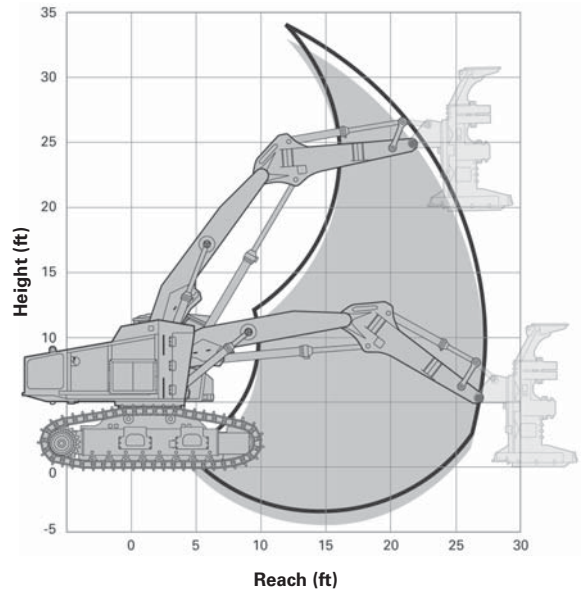

NOTE: \_\_\_\_ Line represents Tilter Model.

### Lift Over Front of Tracks

MODEL	541 Series 2		552 Series 2	
<b>Reach</b>	<b>Lift Capacity</b>		<b>Lift Capacity</b>	
<b>Linkage</b>	<b>Standard Felling</b>		<b>Standard Felling</b>	
3.2 m (10'6")	21 600 kg	47,600 lb	22 200 kg	48,900 lb
4.5 m (15'0")	15 200 kg	33,500 lb	15 500 kg	34,200 lb
6.6 m (21'8")	9888 kg	21,800 lb	9888 kg	21,800 lb
<b>Reach</b>	<b>Lift Capacity</b>		<b>Lift Capacity</b>	
<b>Linkage</b>	<b>Long Felling</b>		<b>Long Felling</b>	
3.0 m (10'0")	20 800 kg	45,900 lb	21 800 kg	48,000 lb
6.1 m (20'0")	10 400 kg	22,900 lb	10 900 kg	24,000 lb
8.2 m (27'0")	6400 kg	14,100 lb	7700 kg	16,900 lb

### Lift Over Side of Tracks

MODEL	541 Series 2		552 Series 2	
<b>Reach</b>	<b>Lift Capacity</b>		<b>Lift Capacity</b>	
<b>Linkage</b>	<b>Standard Felling</b>		<b>Standard Felling</b>	
3.2 m (10'6")	19 400 kg	42,800 lb	22 200 kg	48,900 lb
4.5 m (15'0")	10 600 kg	23,400 lb	14 900 kg	32,800 lb
6.6 m (21'8")	6100 kg	13,400 lb	8600 kg	19,000 lb
<b>Reach</b>	<b>Lift Capacity</b>		<b>Lift Capacity</b>	
<b>Linkage</b>	<b>Long Felling</b>		<b>Long Felling</b>	
3.0 m (10'0")	20 800 kg	45,900 lb	21 800 kg	48,000 lb
6.1 m (20'0")	6600 kg	14,500 lb	9300 kg	20,500 lb
8.2 m (27'0")	4100 kg	9000 lb	6000 kg	13,200 lb

NOTE: Lift Capacity shown without attachment.  
Additional reach and attachment weight will reduce lift capacity.

**563D/573D Wheel Feller Buncher Features:**

- The D Series has been designed for **maximum performance and versatility** to meet multiple customer applications.
- Durable C7.1 ACERT Engine with ACERT Technology meets the demanding power requirements of wheel feller buncher applications while meeting Tier 4 Final/Stage IV/Japan 2014 (Tier 4 Final) emission standards.
- The **high capacity cooling system**, with a hydraulic on-demand reversing fan is designed to operate in high ambient air temperatures and high debris applications while improving component life.
- The **load sense hydraulic systems** provide power on demand and multi-functioning capabilities to all functions of the machine while minimizing fuel consumption.
- A **robust drivetrain** includes a proven hydrostatic drive system and robust Cat axles capable of operating dual tire or wide tire configurations increasing versatility and durability.
- **Heavy duty structures** utilize stream line box section design features, field proven dual taper roller bearing hitch design, integrated steering cylinder mounts, parent plate steering cylinder mounts and oversized chrome plated pins to provide increased life.

- The **transverse mounted engine** provides superior machine stability while providing ground level, single side engine service, ground level fuel and diesel exhaust fluid (DEF) fill, hinged service panels, and pressurized engine/hydraulic and Cat emissions module compartments minimizing potential debris accumulation.
- **Serviceability** has been improved by the transverse mounted engine and other standard features like an electric hydraulic oil fill pump, tilting cab, strategic bulkheads and routings to improve hose and wire harness life and serviceability, and machine fault codes displayed as a text message on the machine monitor to minimize downtime for daily checks, preventative maintenance, and emergency service.
- The **refined operator's station** is positioned evenly between the axles to provide excellent ride quality along with the standard air suspension Cat Comfort seat, high capacity HVAC system, rearview camera, simplified control adjustments and ergonomic controls to reduce operator fatigue.
- **PowerDirect Plus system** optimizes the machine's performance by monitoring operator and attachment demand and delivering power where and when it is needed.

MODEL	563D		573D	
	152 kW	203 hp	180 kW	241 hp
Gross Power				
Engine Model	<b>C7.1 ACERT</b>		<b>C7.1 ACERT</b>	
Engine Speed	<b>1880 RPM</b>		<b>1880 RPM</b>	
Travel Speed (Low Range with 28L x 26 tires)	0-7.2 km/h	<b>0-4.5 mph</b>	0-7.2 km/h	<b>0-4.5 mph</b>
Travel Speed (High Range with 28L x 26 tires)	0-19.8 km/h	<b>0-12.3 mph</b>	0-19.8 km/h	<b>0-12.3 mph</b>
Hydrostatic Pump (Variable displacement piston pump)	242 L/min @ 37 370 kPa	<b>64 gpm @ 5420 si</b>	242 L/min @ 37 370 kPa	<b>64 gpm @ 5420 psi</b>
Primary Hydraulic Pump (Variable displacement piston pump)	155 L/min @ 27 579 kPa	<b>41 gpm @ 4000 psi</b>	155 L/min @ 27 579 kPa	<b>41 gpm @ 4000 psi</b>
Attachment Pump (Variable displacement piston pump)	155 L/min @ 27 579 kPa	<b>41 gpm @ 4000 psi</b>	155 L/min @ 27 579 kPa	<b>41 gpm @ 4000 psi</b>
Fuel Capacity	306 L	<b>81 U.S. gal</b>	306 L	<b>81 U.S. gal</b>

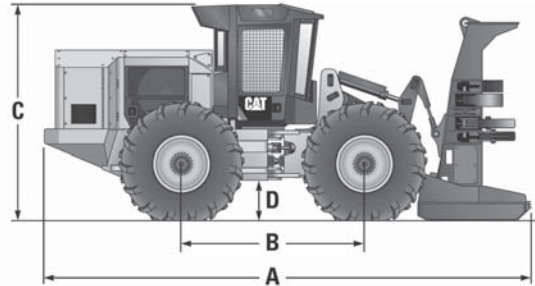
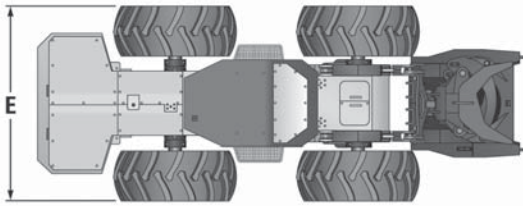

MODEL	563D		573D	
<b>A</b> Overall Length				
Length (with HFW232 High Capacity Saw)	7713 mm	<b>303.7"</b>	7841 mm	<b>308.7"</b>
Length (with HFW221 Felling Saw)	7546 mm	<b>297.1"</b>	7673 mm	<b>302.1"</b>
Length (with HFW222SC Felling Saw)	7509 mm	<b>295.6"</b>	7635 mm	<b>300.6"</b>
<b>B</b> Wheelbase	2794 mm	<b>110.0"</b>	2921 mm	<b>115.0"</b>
<b>C</b> Overall Height				
24.5L x 32	3306 mm	<b>130.2"</b>	3306 mm	<b>130.2"</b>
28L x 26 NOAW	3223 mm	<b>126.9"</b>	3223 mm	<b>126.9"</b>
28L x 26	3223 mm	<b>126.9"</b>	3223 mm	<b>126.9"</b>
30.5L x 32 NOAW	3324 mm	<b>130.9"</b>	3324 mm	<b>130.9"</b>
30.5L x 32	3324 mm	<b>130.9"</b>	3324 mm	<b>130.9"</b>
30.5L x 32 Dual Inner	3324 mm	<b>130.9"</b>	3324 mm	<b>130.9"</b>
67 x 34	3251 mm	<b>128.0"</b>	3251 mm	<b>128.0"</b>
<b>D</b> Ground Clearance				
24.5L x 32 NOAW Offset	610.2 mm	<b>24.0"</b>	610.2 mm	<b>24.0"</b>
28L x 26 NOAW Offset	527.2 mm	<b>20.8"</b>	527.2 mm	<b>20.8"</b>
28L x 26 Standard Offset	527.2 mm	<b>20.8"</b>	527.2 mm	<b>20.8"</b>
30.5L x 32 NOAW Offset	628.2 mm	<b>24.7"</b>	628.2 mm	<b>24.7"</b>
30.5L x 32 Standard Offset	628.2 mm	<b>24.7"</b>	628.2 mm	<b>24.7"</b>
30.5L x 32 Dual Inner	628.2 mm	<b>24.7"</b>	628.2 mm	<b>24.7"</b>
67 x 34 Standard Offset	555.2 mm	<b>21.9"</b>	555.2 mm	<b>21.9"</b>
<b>E</b> Overall Width				
24.5L x 32	2801 mm	<b>110.3"</b>	2801 mm	<b>110.3"</b>
28L x 26 NOAW	2793 mm	<b>110.0"</b>	2793 mm	<b>110.0"</b>
28L x 26	2920 mm	<b>115.0"</b>	2920 mm	<b>115.0"</b>
30.5L x 32 NOAW	2980 mm	<b>117.3"</b>	2980 mm	<b>117.3"</b>
30.5L x 32	3140 mm	<b>123.6"</b>	3140 mm	<b>123.6"</b>
30.5L x 32 Dual Inner	2966 mm	<b>116.8"</b>	2966 mm	<b>116.8"</b>
67 x 34	3222 mm	<b>126.9"</b>	3222 mm	<b>126.9"</b>

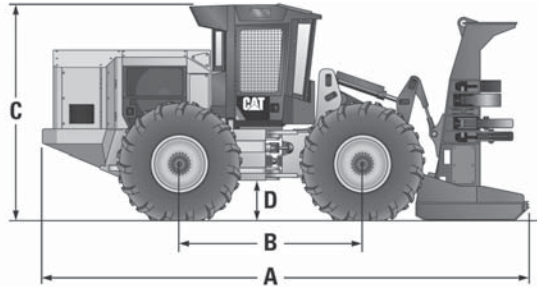
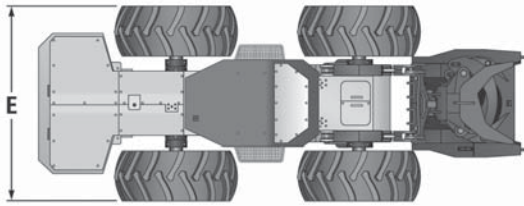

MODEL	563D		573D	
<b>F</b> Articulation Angle				
24.5L x 32		40°		45°
28L x 26 NOAW		45°		45°
28L x 26		45°		45°
30.5L x 32 NOAW		37°		40°
30.5L x 32		35°		45°
30.5L x 32 Dual Inner		37°		40°
67 x 34		37°		42°
<b>G</b> Turning Radius				
24.5L x 32	5323 mm	209.6"	5043 mm	198.6"
28L x 26 NOAW	4845 mm	190.7"	5022 mm	197.7"
28L x 26	4883 mm	192.2"	5085 mm	200.2"
30.5L x 32 NOAW	5731 mm	225.6"	5595 mm	220.3"
30.5L x 32	6062 mm	238.7"	5674 mm	223.4"
30.5L x 32 Dual Inner	5728 mm	225.5"	5595 mm	220.3"
67 x 34	5858 mm	230.6"	5528 mm	217.6"
<b>H</b> Weight, less Attachment				
24.5L x 32	14 560 kg	32,100 lb	14 914 kg	32,880 lb
28L x 26 NOAW	14 578 kg	32,140 lb	14 932 kg	32,920 lb
28L x 26	14 578 kg	32,140 lb	14 932 kg	32,920 lb
30.5L x 32 NOAW	15 358 kg	33,860 lb	15 712 kg	34,640 lb
30.5L x 32	15 358 kg	33,860 lb	15 712 kg	34,640 lb
30.5L x 32 Dual Inner	15 739 kg	34,700 lb	16 093 kg	35,480 lb
67 x 34	15 358 kg	33,860 lb	15 712 kg	34,640 lb

**Track Feller Buncher Heads (Available with Partial Lateral and Full Lateral Tilt)**

<b>MODEL</b>	<b>HF201B</b>	
Accumulation Area	0.46 m <sup>2</sup>	<b>5.0 ft<sup>2</sup></b>
Maximum Cut	572 mm	<b>22.5"</b>
Width	1702 mm	<b>67"</b>
Height (including skids)	2910 mm	<b>114.5"</b>
Weight (PLT)	3200 kg	<b>7054 lb</b>
Weight (FLT)	3669 kg	<b>8090 lb</b>

**Wheel Feller Buncher Heads**

<b>MODEL</b>	<b>HFV232</b>		<b>HFV221</b>		<b>HFV222SC</b>	
Accumulation Area	0.80 m <sup>2</sup>	<b>8.6 ft<sup>2</sup></b>	0.47 m <sup>2</sup>	<b>5.1 ft<sup>2</sup></b>	0.37 m <sup>2</sup>	<b>4.0 ft<sup>2</sup></b>
Maximum Single Cut	573 mm	<b>22.6"</b>	576 mm	<b>22.7"</b>	560 mm	<b>22.0"</b>
Directional Felling Capacity	<b>N/A</b>		<b>N/A</b>		762 mm	<b>30.0"</b>
Width	1734 mm	<b>68.3"</b>	1615 mm	<b>63.6"</b>	1727 mm	<b>68.0"</b>
Height	2763 mm	<b>108.8"</b>	3023 mm	<b>119.0"</b>	2413 mm	<b>95.0"</b>
Weight	2847 kg	<b>6277 lb</b>	3220 kg	<b>7100 lb</b>	2973 kg	<b>6554 lb</b>

**Features:****Structures:**

- Leveraging a chassis design that has accumulated more than 40,000 hours in demanding felling applications, the SATCO Directional Felling Heads have a strong reputation of being one of the most reliable and efficient directional felling heads on the market.

**Hydraulics:**

- The directional felling heads are 100% hydraulic and do not have any electronics on the head. SATCO's "HOSE THROUGH CENTER" connection to the carrier allows the hoses to travel through the center line of the attaching pins. This prevents the hoses from over bending and causing premature failure. It also protects the hoses from damage when falling trees in dense forests. In addition, the 360 degree continuous rotation rotator allows felling in any possible direction in relation to the carrier without being limited by a rotation stop and without the possibility to damage hoses from over rotation of the head.

**Saw Systems:**

- The saw units are supported by a large 30 cm (12 in) diameter slew bearing making them a very robust saw unit especially designed for falling large diameter trees. The saw tensioning adjuster is a heavy duty manual adjuster with  $\frac{3}{4}$ " pitch chain. The heads also use a unique locking system for the saw sprocket to prevent broken drive shaft keys and damaged saw motor shafts.

**Applications:**

- The SAT420 is ideally matched with a Cat 320D FM harvester for efficient felling. The head is most effective when single felling trees between 305–508 mm (12–20 in). The shorter tilt frame and chassis and the smaller jaw opening provide quick motion to reset the felling head for the next cut compared to a SAT630.
- The SAT630 is ideally matched with a Cat 324D FM Harvester or Cat 522B leveling track harvester. The head provides the most benefit when single felling trees between 457–762 mm (18–30 in). However the SAT630 becomes more effective than the SAT420 when the majority of the trees being felled exceed 500 mm (20 in).

**Owning & Operating Costs:**

- Both directional felling heads provide low owning and operating costs when compared to traditional high speed disc felling heads. Not only do the directional felling heads require less horsepower, consume less fuel, the heads also provide less stress on carrier components such as pins, bushings, stick, and boom joints due to the floating motion of the head once the trees are felled.



# Harvesting SATCO Directional Felling Heads

## Specifications

<b>MODEL</b>	<b>SAT420</b>		<b>SAT630</b>	
Weight	1450 kg	<b>3100 lb</b>	2000 kg	<b>4400 lb</b>
Height to Link Pin	2114 mm	<b>83"</b>	2405 mm	<b>95"</b>
Maximum Jaw Open	965 mm	<b>38"</b>	1400 mm	<b>55"</b>
Minimum Jaw Close	100 mm	<b>4"</b>	120 mm	<b>5"</b>
Optimal Capacity	305-508 mm	<b>12-20"</b>	457-762 mm	<b>18-30"</b>
Saw System:				
Chain Tensioning	<b>Manual</b>		<b>Manual</b>	
Chain Pitch	$\frac{3}{4}$ "		$\frac{3}{4}$ "	
Saw Bearing Diameter	305 mm	<b>12"</b>	305 mm	<b>12"</b>
Maximum Cut Diameter	635 mm	<b>25"</b>	950 mm	<b>38"</b>

<b>Directional Felling Heads</b>	<b>Forest Machines</b>	<b>Track Harvesters</b>
<b>SAT420</b>	320D FM/324D FM/325D FM	521B/522B/501HD
<b>SAT630</b>	324D FM/325D FM	521B/522B/541 II/552 II

**Application:**

- This product is specifically designed for applications, which require removal of the bark. The HH44 DE cannot be used in a standard harvesting application.

**Features:**

**Operator Station:**

- Utilizes a mobile purpose built Microsoft Windows based computer system.
- Equipped with: color touch screen, heavy-duty processor housing, and mini space saving keyboard with integral track ball mouse.

**Structures:**

- Use of a chassis design that has proven effective in Eucalyptus, improvements were made to the structure to provide a durable frame for high cycle debarking applications.

**Hydraulics:**

- Heavy Duty double-hinged self-aligning covers allow for superior access and easier serviceability to the hydraulic valve.
- Mono-block valve decreases maintenance repairs and gives users easier control of all harvester head functions.

**Measuring Devices:**

- New length and diameter measuring systems increase reliability and reduces maintenance.
- Wide temperature range ensures accurate measurements.

**Hoses:**

- Cat XT™ ES (Enhanced Spiral) ToughGuard hoses are designed to have exceptional abrasion resistance and increased flexibility superior to standard hoses.

MODEL	HH44 DE	
Knives	2 fixed, 4 moveable	
Maximum Roller Opening	620 mm	24.4"
Maximum Opening Upper Knives	603 mm	23.7"
Maximum Opening Lower Knives	703 mm	27.7"
Feed Force	0-22.6 kN @ 25 MPa	0-5076 lb @ 3625 psi
Feed Speed	0-5.7 m/sec	0-18.8 ft/sec
Weight	1542 kg	3400 lb
Main Saw:		
Bar Pitch/Type	10 mm	0.404"
Bar Length	750 mm	29.5"
Maximum Diameter Cut	650 mm	25.5"
Maximum Chain Speed	40 m/sec	130 ft/sec
Hydraulic Pressure Requirement Maximum	25 MPa	3620 psi
Hydraulic Flow Requirement Minimum	184 L/min	48 gpm

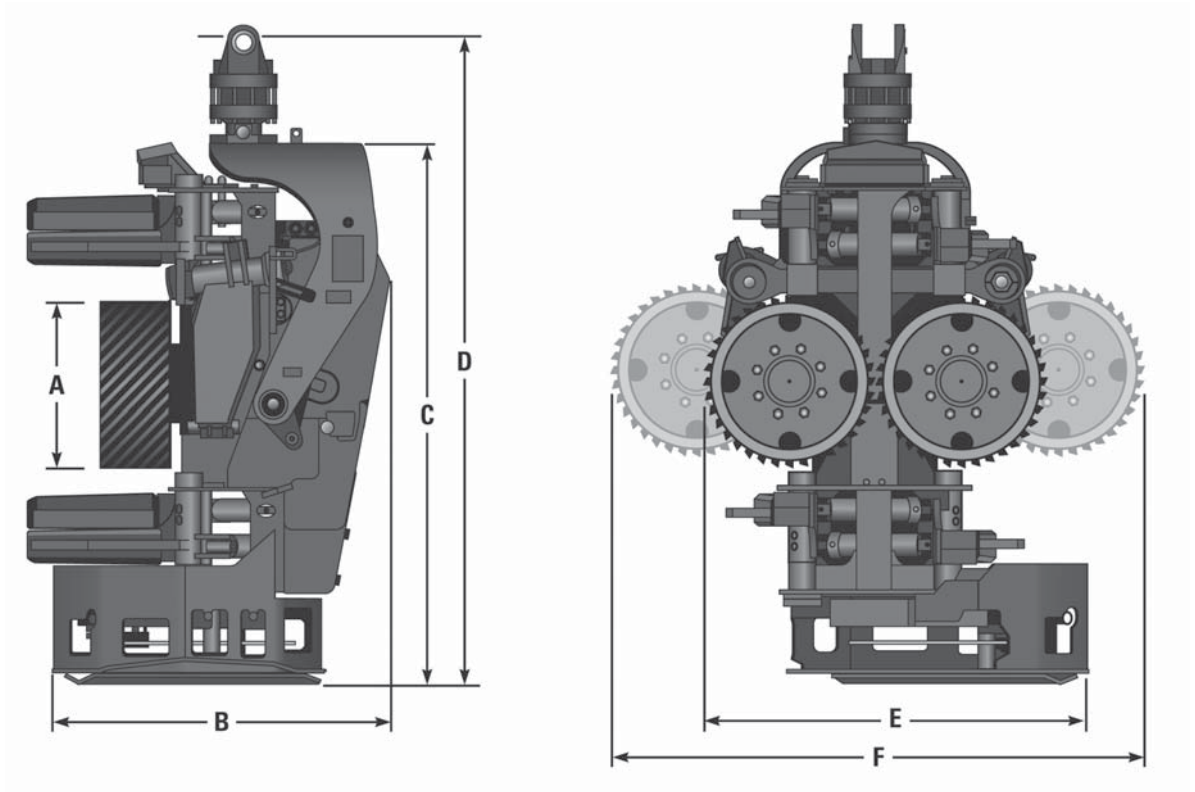

	<b>A</b>	<b>B</b>	<b>C</b>	<b>D</b>	<b>E</b>	<b>F</b>
<b>mm</b>	550	1080	1726	2057	1272	1772
<b>in</b>	21.7	42.5	68.0	81.0	50.0	69.8

**Features:****Structures:**

- SATCO processing heads are designed with high tensile strength materials and utilize large pins for durability. The roller arm and knife pins on the heads are retained using SATCO's "DEAD-LOCK" pin retention system utilizing the pin for added strength in the chassis. The "DEAD-LOCK" pin retention system also prevents the pin from moving in all three axis improving bushing life and extending service intervals.

**Hydraulics:**

- A Rex Roth main valve is used on all SATCO processing heads and is rated at 420 bar (6100 psi) eliminating the need for carrier pressure reduction. SATCO's "HOSE THROUGH CENTER" connection to the carrier allows the hoses to travel through the center line of the attaching pins preventing the hoses from over bending and causing premature failure. It also protects the hoses from damage when falling trees in dense forests.

**Saw Systems:**

- SATCO processing heads utilize two different main saw systems depending on the head model. Most heads come equipped with SATCO's designed ¾" manual tension main saw system. The main saw units are supported by a large 30 cm (12 in) diameter slew bearing making them a very robust saw unit. The saw tensioning adjuster is a heavy duty manual adjuster with ¾" pitch chain. The heads also use a unique locking system for the saw sprocket to prevent broken drive shaft keys and damaged saw motor shafts.
- The SAT214, SAT318T SC, SAT322T SC, and SAT323T SC all utilize the Hultins SuperCut 100. The SC100 features 0.404" automatic chain tensioning and an integrated lubrication system.
- The SuperCut 100 is also used on most of the heads denoted by a "T" as a topping saw. This feature provides added versatility to the operator when processing. The one exception is the SAT325T which is equipped with the same SATCO designed ¾" saw system for both the main and topping saws.

**Applications:**

- The SAT214 is designed for pine thinning and select cutting smaller mixed stands. This head performs well in pine plantations and mixed natural stands.
- The SAT318/SAT318T/SAT318T SC are equipped with TMVW drive motors designed for lighter weight timber and perfect for feeding down to small diameters.
- The SAT322/SAT322T/SAT322T SC are equipped with HD hubs on the drive motors and work perfectly for larger heavy timber while still maintaining the ability to install on a 320D FM or a 521B/522B track harvester.
- The SAT323/SAT323T/SAT323T SC are equipped with MS11 drive motors providing increased torque. These heads paired with the 324D FM/325D FM machines have the capacity to consistently process large timber.
- The "SC" versions of the 18, 22, 23 inch heads works well for softwood applications and provides faster cutting cycles.
- Debarking is the specialty of the SAT422 DB and can handle a wide range of eucalyptus and acacia trees.
- The SAT223/SAT223T are best suited for processing short wood (6 m [20 ft]) or less. It is equipped with four knives and provides optimal delimiting of large limby wood.
- The largest offering is the SAT325/SAT325T and is designed for our largest FM the 568 FM. These heads work with the largest timber our machines can handle and stand up to the toughest applications.

**Control System:**

- SATCO heads have two control system options the Plus-1 and d5 Bucking Prio designed to suit many markets around the Globe.
- The Plus-1 system provides diameter based priority cut selection, simple length and diameter calibrations, metric or imperial display units as well as multiple languages. The Plus-1 measuring and control system is simple to use and does not require a PC in the cab. The system is ideal for customers who do not require sophisticated measuring systems.

- The d5 Bucking Prio control system is focused on simplicity, ease of operation, and provides priority bucking by prioritizing length and diameter calculations. The system also has the ability for production reporting and adding additional applications such as GPS\* and Operational Monitoring\*.

\*Optional.

<b>MODEL</b>	<b>SAT214</b>	
Knives	<b>1 Upper Fixed 4 Moveable/4 Cutting Edges</b>	
Weight	1370 kg	<b>3020 lb</b>
Capacity	30-350 mm	<b>1.25-14"</b>
Close Minimum	30 mm	<b>1.25"</b>
Maximum Top Knives Open	600 mm	<b>24"</b>
Maximum Bottom Knives Open	600 mm	<b>24"</b>
Maximum Rollers Open	600 mm	<b>24"</b>
Maximum Feed Force:		
2 × TMVW 500 cc	18 kN	<b>4046 lbf</b>
2 × TMVW 630 cc	21 kN	<b>4721 lbf</b>
Maximum Feed Speed:		
2 × TMVW 500 cc	6 m/sec	<b>19.7 ft/sec</b>
2 × TMVW 630 cc	4.8 m/sec	<b>15.7 ft/sec</b>
Main Saw:		
Bar Pitch/Type	<b>0.404" 18HX</b>	
Bar Length	750 mm	<b>29.5"</b>
Maximum Diameter Cut	640 mm	<b>25"</b>
Chain/Bar Oil Capacity	17 L	<b>4.5 U.S. gal</b>
Recommended Hydraulic Pressure	300 bar	<b>4351 psi</b>
Recommended Hydraulic Flow	160 L/min	<b>42 gpm</b>
<b>Dimensions:</b>		
Roller Diameter	390 mm	<b>15"</b>
Depth	1080 mm	<b>42.5"</b>
Height to Rotator Pin	1950 mm	<b>77"</b>
Width Rollers Closed	1140 mm	<b>45"</b>
Width Rollers Open	1380 mm	<b>54.5"</b>

MODEL	SAT318		SAT318T		SAT318T SC	
Knives — Single and Single	<b>1 Upper Floating 2 Moveable/ 2 Cutting Edges</b>		<b>1 Upper Floating 2 Moveable/ 2 Cutting Edges</b>		<b>1 Upper Floating 2 Moveable/ 2 Cutting Edges</b>	
Weight	2486 kg	<b>5481 lb</b>	—	—	—	—
Weight with Topping Saw	—	—	2752 kg	<b>6067 lb</b>	2782 kg	<b>6133 lb</b>
TMVW Motors:						
Capacity	50-457 mm	<b>2-18"</b>	50-457 mm	<b>2-18"</b>	50-457 mm	<b>2-18"</b>
Close Minimum	50 mm	<b>2"</b>	50 mm	<b>2"</b>	50 mm	<b>2"</b>
Maximum Knives Open	690 mm	<b>27"</b>	690 mm	<b>27"</b>	690 mm	<b>27"</b>
Maximum Rollers Open	800 mm	<b>31.5"</b>	800 mm	<b>31.5"</b>	800 mm	<b>31.5"</b>
Maximum Feed Force:						
4 × 630 cc Motors	40 kN	<b>9000 lbf</b>	40 kN	<b>9000 lbf</b>	40 kN	<b>9000 lbf</b>
Maximum Feed Speed:						
4 × 630 cc Motors	4.8 m/sec	<b>16 ft/sec</b>	4.8 m/sec	<b>16 ft/sec</b>	4.8 m/sec	<b>16 ft/sec</b>
Main Saw:						
Bar Pitch/Type	<b>¾"/11BC</b>		<b>¾"/11BC</b>		<b>0.404"/18HX</b>	
Bar Length	914 mm	<b>36"</b>	914 mm	<b>36"</b>	902 mm	<b>35"</b>
Maximum Diameter Cut	730 mm	<b>29"</b>	730 mm	<b>29"</b>	730 mm	<b>29"</b>
Topping Saw Option:						
Bar Pitch/Type	—	—	<b>0.404"/18HX</b>		<b>0.404"/18HX</b>	
Bar Length	—	—	672 mm	<b>26"</b>	672 mm	<b>26"</b>
Maximum Diameter Cut	—	—	460 mm	<b>18"</b>	460 mm	<b>18"</b>
Chain/Bar Oil Capacity	17 L	<b>4.5 U.S. gal</b>	15 L	<b>4.0 U.S. gal</b>	15 L	<b>4.0 U.S. gal</b>
Recommended Hydraulic Pressure	300 bar	<b>4351 psi</b>	300 bar	<b>4351 psi</b>	300 bar	<b>4351 psi</b>
Recommended Hydraulic Flow	300 L/min	<b>79 gpm</b>	300 L/min	<b>79 gpm</b>	300 L/min	<b>79 gpm</b>
<b>Dimensions:</b>						
Roller Diameter — Thumbnail	390 mm	<b>15"</b>	390 mm	<b>15"</b>	390 mm	<b>15"</b>
Depth	1370 mm	<b>54"</b>	1370 mm	<b>54"</b>	1450 mm	<b>54"</b>
Height to Rotator Pin	1950 mm	<b>77"</b>	2210 mm	<b>87"</b>	2140 mm	<b>84"</b>
Width Rollers Closed	1720 mm	<b>68"</b>	1720 mm	<b>68"</b>	1680 mm	<b>66"</b>
Width Rollers Open	1910 mm	<b>75"</b>	1900 mm	<b>75"</b>	1900 mm	<b>75"</b>

<b>MODEL</b>	<b>SAT322</b>		<b>SAT322T</b>		<b>SAT322T SC</b>	
Knives — Single and Single	<b>1 Upper Floating 2 Moveable/ 2 Cutting Edges</b>		<b>1 Upper Floating 2 Moveable/ 2 Cutting Edges</b>		<b>1 Upper Floating 2 Moveable/ 2 Cutting Edges</b>	
Weight	2486 kg	<b>5481 lb</b>	—	—	—	—
Weight with Topping Saw	—	—	2752 kg	<b>6067 lb</b>	2782 kg	<b>6133 lb</b>
HD Hubs — OMV Drive Motors:						
Capacity	75-560 mm	<b>3-22"</b>	75-560 mm	<b>3-22"</b>	75-560 mm	<b>3-22"</b>
Close Minimum	75 mm	<b>3"</b>	75 mm	<b>3"</b>	75 mm	<b>3"</b>
Maximum Knives Open	690 mm	<b>27"</b>	690 mm	<b>27"</b>	690 mm	<b>27"</b>
Maximum Rollers Open	800 mm	<b>31.5"</b>	800 mm	<b>31.5"</b>	800 mm	<b>31.5"</b>
Maximum Feed Force:						
Debarking Configuration Only	30 kN	<b>6745 lbf</b>	—	—	—	—
4 x 630 cc Motors	40 kN	<b>9000 lbf</b>	40 kN	<b>9000 lbf</b>	40 kN	<b>9000 lbf</b>
Maximum Feed Speed:						
Debarking Configuration Only	5.8 m/sec	<b>19 ft/sec</b>	—	—	—	—
4 x 630 cc Motors	4.8 m/sec	<b>16 ft/sec</b>	4.8 m/sec	<b>16 ft/sec</b>	4.8 m/sec	<b>16 ft/sec</b>
Main Saw:						
Bar Pitch/Type	<b>¾"/11BC</b>		<b>¾"/11BC</b>		<b>0.404"/18HX</b>	
Bar Length	914 mm	<b>36"</b>	914 mm	<b>36"</b>	902 mm	<b>35"</b>
Maximum Diameter Cut	730 mm	<b>29"</b>	730 mm	<b>29"</b>	730 mm	<b>29"</b>
Topping Saw Option:						
Bar Pitch/Type	—	—	<b>0.404"/18HX</b>		<b>0.404"/18HX</b>	
Bar Length	—	—	672 mm	<b>26"</b>	672 mm	<b>26"</b>
Maximum Diameter Cut	—	—	460 mm	<b>18"</b>	460 mm	<b>18"</b>
Chain/Bar Oil Capacity	17 L	<b>4.5 U.S. gal</b>	15 L	<b>4.0 U.S. gal</b>	15 L	<b>4.0 U.S. gal</b>
Recommended Hydraulic Pressure	300 bar	<b>4351 psi</b>	300 bar	<b>4351 psi</b>	300 bar	<b>4351 psi</b>
Recommended Hydraulic Flow	300 L/min	<b>79 gpm</b>	300 L/min	<b>79 gpm</b>	300 L/min	<b>79 gpm</b>
<b>Dimensions:</b>						
Roller Diameter — Thumbnail	390 mm	<b>15"</b>	390 mm	<b>15"</b>	390 mm	<b>15"</b>
Roller Diameter — Debarking	480 mm	<b>19"</b>	480 mm	<b>19"</b>	480 mm	<b>19"</b>
Depth	1370 mm	<b>54"</b>	1370 mm	<b>54"</b>	1450 mm	<b>54"</b>
Height to Rotator Pin	1950 mm	<b>77"</b>	2210 mm	<b>87"</b>	2140 mm	<b>84"</b>
Width Rollers Closed	1720 mm	<b>68"</b>	1720 mm	<b>68"</b>	1680 mm	<b>66"</b>
Width Rollers Open	1900 mm	<b>75"</b>	1900 mm	<b>75"</b>	1900 mm	<b>75"</b>

**MODEL****SAT422 DB**

<b>MODEL</b>	<b>SAT422 DB</b>	
Knives	<b>1 Upper Fixed 2 Moveable/2 Cutting Edges</b>	
Weight	2808 kg	<b>6191 lb</b>
Capacity	50-560 mm	<b>2-22"</b>
Close Minimum	50 mm	<b>2"</b>
Maximum Knives Open	800 mm	<b>32"</b>
Maximum Rollers Open	740 mm	<b>29"</b>
Maximum Feed Force: 4 × Danfoss 500 cc	28 kN	<b>6300 lbf</b>
Maximum Feed Speed: 4 × Danfoss 500 cc	5.8 m/sec	<b>19 ft/sec</b>
Main Saw:		
Bar Pitch/Type	<b>¾"/11BC</b>	
Bar Length	915 mm	<b>36"</b>
Maximum Diameter Cut	630 mm	<b>25"</b>
Chain/Bar Oil Capacity	15 L	<b>4 U.S. gal</b>
Recommended Hydraulic Pressure	300 bar	<b>4351 psi</b>
Recommended Hydraulic Flow	300 L/min	<b>79 gpm</b>
<b>Dimensions:</b>		
Roller Diameter	380 mm	<b>15"</b>
Depth	1430 mm	<b>56.5"</b>
Height to Rotator Pin	2280 mm	<b>90"</b>
Width Rollers Closed	1600 mm	<b>63"</b>
Width Rollers Open	1760 mm	<b>69"</b>



<b>MODEL</b>	<b>SAT323</b>		<b>SAT323T</b>		<b>SAT323T SC</b>	
Knives – “TRI-KNIFE” System	<b>1 Upper Floating 2 Moveable/ 3 Cutting Edges</b>		<b>1 Upper Floating 2 Moveable/ 3 Cutting Edges</b>		<b>1 Upper Floating 2 Moveable/ 3 Cutting Edges</b>	
Weight	2530 kg	<b>5578 lb</b>	—	—	—	—
Weight with Topping Saw	—	—	2790 kg	<b>6151 lb</b>	2810 kg	<b>6203 lb</b>
MS11 Motors:						
Capacity	50-590 mm	<b>2-23"</b>	50-590 mm	<b>2-23"</b>	50-590 mm	<b>2-23"</b>
Close Minimum	50 mm	<b>2"</b>	50 mm	<b>2"</b>	50 mm	<b>2"</b>
Maximum Knives Open	690 mm	<b>27"</b>	690 mm	<b>27"</b>	690 mm	<b>27"</b>
Maximum Rollers Open	800 mm	<b>31.5"</b>	800 mm	<b>31.5"</b>	800 mm	<b>31.5"</b>
Maximum Feed Force:						
2 × 630 cc, 2 × 837 cc Motors	42 kN	<b>9445 lbf</b>	42 kN	<b>9445 lbf</b>	42 kN	<b>9445 lbf</b>
Maximum Feed Speed:						
2 × 630 cc, 2 × 837 cc MS 11 Motors	5.5 m/sec	<b>18 ft/sec</b>	5.5 m/sec	<b>18 ft/sec</b>	5.5 m/sec	<b>18 ft/sec</b>
Main Saw:						
Bar Pitch/Type	<b>¾"/11BC</b>		<b>¾"/11BC</b>		<b>0.404in/18HX</b>	
Bar Length	914 mm	<b>36"</b>	914 mm	<b>36"</b>	902 mm	<b>35"</b>
Maximum Diameter Cut	730 mm	<b>29"</b>	730 mm	<b>29"</b>	730 mm	<b>29"</b>
Topping Saw Option:						
Bar Pitch/Type	—	—	<b>0.404"/18HX</b>		<b>0.404"/18HX</b>	
Bar Length	—	—	672 mm	<b>26"</b>	672 mm	<b>26"</b>
Maximum Diameter Cut	—	—	460 mm	<b>18"</b>	460 mm	<b>18"</b>
Chain/Bar Oil Capacity	17 L	<b>4.5 U.S. gal</b>	15 L	<b>4.0 U.S. gal</b>	15 L	<b>4.0 U.S. gal</b>
Recommended Hydraulic Pressure	300 bar	<b>4351 psi</b>	300 bar	<b>4351 psi</b>	300 bar	<b>4351 psi</b>
Recommended Hydraulic Flow	300 L/min	<b>79 gpm</b>	300 L/min	<b>79 gpm</b>	300 L/min	<b>79 gpm</b>
<b>Dimensions:</b>						
Roller Diameter – Thumbnail	515 mm	<b>20"</b>	515 mm	<b>20"</b>	515 mm	<b>20"</b>
Depth	1370 mm	<b>54"</b>	1370 mm	<b>54"</b>	1450 mm	<b>54"</b>
Height to Rotator Pin	1950 mm	<b>77"</b>	2210 mm	<b>87"</b>	2140 mm	<b>84"</b>
Width Rollers Closed	1720 mm	<b>68"</b>	1720 mm	<b>68"</b>	1680 mm	<b>66"</b>
Width Rollers Open	1900 mm	<b>75"</b>	1900 mm	<b>75"</b>	1900 mm	<b>75"</b>

<b>MODEL</b>	<b>SAT223</b>		<b>SAT223T</b>	
Knives	<b>1 Upper Floating 4 Moveable/4 Cutting Edges</b>		<b>1 Upper Floating 4 Moveable/4 Cutting Edges</b>	
Weight	3340 kg	<b>7363 lb</b>	3600 kg	<b>7937 lb</b>
Weight with Topping Saw	—		3545 kg	<b>7800 lb</b>
Capacity	60-590 mm	<b>2-23"</b>	60-590 mm	<b>2-23"</b>
Close Minimum	60 mm	<b>2.4"</b>	60 mm	<b>2.4"</b>
Maximum Top Knives Open	850 mm	<b>33.5"</b>	850 mm	<b>33.5"</b>
Maximum Bottom Knives Open	750 mm	<b>29.5"</b>	750 mm	<b>29.5"</b>
Maximum Rollers Open	800 mm	<b>31.5"</b>	800 mm	<b>31.5"</b>
Maximum Feed Force: 2 × MS11 1048 cc	45 kN	<b>10,125 lbf</b>	45 kN	<b>10,125 lbf</b>
Maximum Feed Speed: 2 × MS11 1048 cc	4.8 m/sec	<b>15.7 ft/sec</b>	4.8 m/sec	<b>15.7 ft/sec</b>
Main Saw:				
Bar Pitch/Type	<b>¾"/11BC</b>		<b>¾"/11BC</b>	
Bar Length	914 mm	<b>36"</b>	914 mm	<b>36"</b>
Maximum Diameter Cut	750 mm	<b>29.5"</b>	750 mm	<b>29.5"</b>
Topping Saw Option:				
Bar Pitch/Type	—		<b>0.404"/18HX</b>	
Bar Length	—		750 mm	<b>29.5"</b>
Maximum Diameter Cut	—		400 mm	<b>15.5"</b>
Chain/Bar Oil Capacity	15 L	<b>4 U.S. gal</b>	15 L	<b>4 U.S. gal</b>
Recommended Hydraulic Pressure	350 bar	<b>5076 psi</b>	350 bar	<b>5076 psi</b>
Recommended Hydraulic Flow	380 L/min	<b>100 gpm</b>	380 L/min	<b>100 gpm</b>
<b>Dimensions:</b>				
Roller Diameter — Thumbnail	550 mm	<b>21.5"</b>	550 mm	<b>21.5"</b>
Depth	1390 mm	<b>55"</b>	1390 mm	<b>55"</b>
Height to Rotator Pin	2400 mm	<b>95"</b>	2400 mm	<b>95"</b>
Width Rollers Closed	1580 mm	<b>62"</b>	1580 mm	<b>62"</b>
Width Rollers Open	1890 mm	<b>74.5"</b>	1890 mm	<b>74.5"</b>

<b>MODEL</b>	<b>SAT325</b>		<b>SAT325T</b>	
Knives – Tri-Knife System	<b>1 Upper Floating 2 Moveable/3 Cutting Edges</b>		<b>1 Upper Floating 2 Moveable/3 Cutting Edges</b>	
Weight	3580 kg	<b>7893 lb</b>	4108 kg	<b>9057 lb</b>
Capacity	75-660 mm	<b>3-26"</b>	75-660 mm	<b>3-26"</b>
Close Minimum	75 mm	<b>3"</b>	75 mm	<b>3"</b>
Maximum Top Knives Open	1000 mm	<b>40"</b>	1000 mm	<b>40"</b>
Maximum Bottom Knives Open	<b>N/A</b>		<b>N/A</b>	
Maximum Rollers Open	1000 mm	<b>40"</b>	1000 mm	<b>40"</b>
Maximum Feed Force:				
2 × Poclairn 837 cc and 2 × Danfoss 500cc	48 kN	<b>10,790 lbf</b>	48 kN	<b>10,790 lbf</b>
2 × Poclairn 1048 cc and 2 × Danfoss 630cc	55 kN	<b>12,365 lbf</b>	55 kN	<b>12,365 lbf</b>
Maximum Feed Speed:				
2 × Poclairn 837 cc and 2 × Danfoss 500cc	5.1 m/sec	<b>17 ft/sec</b>	5.1 m/sec	<b>17 ft/sec</b>
2 × Poclairn 1048 cc and 2 × Danfoss 630cc	4.1 m/sec	<b>13.5 ft/sec</b>	4.1 m/sec	<b>13.5 ft/sec</b>
Main Saw:				
Bar Pitch/Type	<b>¾"/11BC</b>		<b>¾"/11BC</b>	
Bar Length	1092 mm	<b>43"</b>	1092 mm	<b>43"</b>
Maximum Diameter Cut	800 mm	<b>31.5"</b>	800 mm	<b>31.5"</b>
Topping Saw Option:				
Bar Pitch/Type	—		<b>¾"/11BC</b>	
Bar Length	—		1092 mm	<b>43"</b>
Maximum Diameter Cut	—		690 mm	<b>27"</b>
Chain/Bar Oil Capacity	17 L	<b>4.5 U.S. gal</b>	17 L	<b>4.5 U.S. gal</b>
Recommended Hydraulic Pressure	350 bar	<b>5076 psi</b>	350 bar	<b>5076 psi</b>
Recommended Hydraulic Flow	380 L/min	<b>100 gpm</b>	380 L/min	<b>100 gpm</b>
<b>Dimensions:</b>				
Roller Diameter – Pine and Alpine	445 mm	<b>17.5"</b>	445 mm	<b>17.5"</b>
Depth	1440 mm	<b>57"</b>	1440 mm	<b>57"</b>
Height to Rotator Pin	2580 mm	<b>101"</b>	2850 mm	<b>112"</b>
Width Rollers Closed	1880 mm	<b>74"</b>	1880 mm	<b>74"</b>
Width Rollers Open	1970 mm	<b>77.5"</b>	1970 mm	<b>77.5"</b>

**525D/535D/545D/555D Wheel Skidder Features:**

- The Cat C7.1 ACERT engine is designed to deliver more power than ever before, while still achieving the highest levels of total fluid efficiency, reliability and durability.
- The **high capacity cooling system** and on-demand hydraulically driven reversing fan keep the machine running at the proper operating temperature, optimizing performance, durability and fuel efficiency. The system, designed to meet the cooling requirements of the 555D, is common to all models, boosting fuel efficiency and capacity in the smaller models.
- Power to the ground is an advantage of the Cat D Series **power train**. The axles are designed specifically for the skidder application and the gear ratios cause the power to be generated in the axles reducing torque in the transmission and drivelines extending their life. Both drawbar performance and durability are improved.
- The **high performance hydraulic system** provides more speed, increased multifunctioning capability and greater lift capacity. This efficient load sense system with variable displacement pump continually monitors hydraulic power requirements and provides power based on demand to save fuel.
- **Rock solid stability** through improved weight distribution and a longer wheelbase keep the skidder solid, even in turns. Robust frames provide a solid foundation for a machine designed to provide long life. Every structure was engineered for durability and verified through lab and field tests.
- Logging and retrieval **winches** are available as options. Both are hydraulically driven, have the same pulling power and feature friction style clutches for increased durability and functionality.
- The **refined operator's station** is positioned evenly between the axles to provide excellent ride quality along with the high back air suspension seat, high capacity HVAC system, and ergonomic controls to reduce operator fatigue.
- **Serviceability** of the D Series is significantly improved with the tilting cab, redesigned grapple head and improved hose routings. The cross flow configuration and compartmentalization reduce debris collection around the engine, so less time is needed for cleaning.
- **Integrated technologies** like the machine troubleshooting feature which allows the operator to drill down and pinpoint the root cause of a problem, reducing the need for service calls and holding down costs. Product Link™ is also integrated to collect and deliver valuable information which is important with logging sites in remote areas.

<b>MODEL</b>	<b>525D</b>		<b>535D</b>	
<b>Engine:</b>	<b>C7.1 ACERT</b>		<b>C7.1 ACERT</b>	
Engine Model				
Gross Power	151 kW	<b>203 hp</b>	168 kW	<b>225 hp</b>
Displacement	7.0 L	<b>428 in<sup>3</sup></b>	7.0 L	<b>428 in<sup>3</sup></b>
Bore	105 mm	<b>4.13"</b>	105 mm	<b>4.13"</b>
Stroke	135 mm	<b>5.31"</b>	135 mm	<b>5.31"</b>
Number of Cylinders	<b>6</b>		<b>6</b>	
Maximum Torque @ 1400 rpm	922 N·m	<b>680 lb-ft</b>	1028 N·m	<b>758 lb-ft</b>
Derating Altitude	3000 m	<b>9843 ft</b>	3000 m	<b>9843 ft</b>
Electrical System	<b>24V</b>		<b>24V</b>	
Battery – Quantity	<b>2</b>		<b>2</b>	
Battery – Volts	<b>12V</b>		<b>12V</b>	
Battery – Capacity	<b>950 CCA</b>		<b>950 CCA</b>	
<b>Power Train:</b>	<b>Countershaft Powershift</b>		<b>Countershaft Powershift</b>	
Transmission	<b>Water to Oil</b>		<b>Water to Oil</b>	
Transmission Cooler Type				
Travel Speed – Fwd 1st	5.6 km/h	<b>3.5 mph</b>	5.6 km/h	<b>3.5 mph</b>
Travel Speed – Fwd 2nd	7.6 km/h	<b>4.7 mph</b>	7.6 km/h	<b>4.7 mph</b>
Travel Speed – Fwd 3rd	10.4 km/h	<b>6.5 mph</b>	10.4 km/h	<b>6.5 mph</b>
Travel Speed – Fwd 4th	14.1 km/h	<b>8.8 mph</b>	14.1 km/h	<b>8.8 mph</b>
Travel Speed – Fwd 5th	18.9 km/h	<b>11.8 mph</b>	18.9 km/h	<b>11.8 mph</b>
Travel Speed – Fwd 6th	20.0 km/h	<b>12.4 mph</b>	20.0 km/h	<b>12.4 mph</b>
Travel Speed – Rev 1st	5.6 km/h	<b>3.5 mph</b>	5.6 km/h	<b>3.5 mph</b>
Travel Speed – Rev 2nd	10.4 km/h	<b>6.5 mph</b>	10.4 km/h	<b>6.5 mph</b>
Travel Speed – Rev 3rd	18.9 km/h	<b>11.8 mph</b>	18.9 km/h	<b>11.8 mph</b>
<b>Brakes:</b>	<b>Enclosed wet single disc</b>		<b>Enclosed wet single disc</b>	
Service	<b>Spring applied, hydraulically released</b>		<b>Spring applied, hydraulically released</b>	
Transmission Cooler Type				
<b>Hydraulic System:</b>	<b>Load sense, closed center</b>		<b>Load sense, closed center</b>	
Type	<b>Variable displacement piston pump</b>		<b>Variable displacement piston pump</b>	
Pump Type				
Pump Output	220 L/min	<b>58 gpm</b>	220 L/min	<b>58 gpm</b>
<b>Service Refill:</b>				
Fuel Tank	315 L	<b>83.2 U.S. gal</b>	378 L	<b>99.8 U.S. gal</b>
DEF Tank*	19 L	<b>5.0 U.S. gal</b>	19 L	<b>5.0 U.S. gal</b>
Engine Oil	27 L	<b>7.1 U.S. gal</b>	27 L	<b>7.1 U.S. gal</b>
Cooling System	57 L	<b>15.1 U.S. gal</b>	57 L	<b>15.1 U.S. gal</b>
Transmission, Torque Converter	54 L	<b>14.3 U.S. gal</b>	54 L	<b>14.3 U.S. gal</b>
Parking Brake	425 mL	<b>14.4 oz</b>	425 mL	<b>14.4 oz</b>
Differential, Final Drive:				
Front	52 L	<b>13.7 U.S. gal</b>	52 L	<b>13.7 U.S. gal</b>
Rear	52 L	<b>13.7 U.S. gal</b>	52 L	<b>13.7 U.S. gal</b>
Hydraulic System:				
Tank	65 L	<b>17.2 U.S. gal</b>	65 L	<b>17.2 U.S. gal</b>
Total	123 L	<b>32.5 U.S. gal</b>	123 L	<b>32.5 U.S. gal</b>

\*Tier 4 Final/Stage IV/Japan 2014 (Tier 4 Final) equipped machines only.

<b>MODEL</b>	<b>545D</b>		<b>555D</b>	
<b>Engine:</b>	<b>C7.1 ACERT</b>		<b>C7.1 ACERT</b>	
Engine Model	186 kW	<b>250 hp</b>	205 kW	<b>275 hp</b>
Gross Power	7.0 L	<b>428 in<sup>3</sup></b>	7.0 L	<b>428 in<sup>3</sup></b>
Displacement	105 mm	<b>4.13"</b>	105 mm	<b>4.13"</b>
Bore	135 mm	<b>5.31"</b>	135 mm	<b>5.31"</b>
Stroke		<b>6</b>		<b>6</b>
Number of Cylinders	1142 N·m	<b>842 lb-ft</b>	1257 N·m	<b>927 lb-ft</b>
Maximum Torque @ 1400 rpm	3000 m	<b>9843 ft</b>	3000 m	<b>9843 ft</b>
Derating Altitude		<b>24V</b>		<b>24V</b>
Electrical System		<b>2</b>		<b>2</b>
Battery — Quantity		<b>12V</b>		<b>12V</b>
Battery — Volts		<b>950 CCA</b>		<b>950 CCA</b>
Battery — Capacity	<b>Countershaft Powershift</b>		<b>Countershaft Powershift</b>	
<b>Power Train:</b>	<b>Water to Oil</b>		<b>Water to Oil</b>	
Transmission	5.6 km/h	<b>3.5 mph</b>	5.6 km/h	<b>3.5 mph</b>
Transmission Cooler Type	7.6 km/h	<b>4.7 mph</b>	7.6 km/h	<b>4.7 mph</b>
Travel Speed — Fwd 1st	10.4 km/h	<b>6.5 mph</b>	10.4 km/h	<b>6.5 mph</b>
Travel Speed — Fwd 2nd	14.1 km/h	<b>8.8 mph</b>	14.1 km/h	<b>8.8 mph</b>
Travel Speed — Fwd 3rd	18.9 km/h	<b>11.8 mph</b>	18.9 km/h	<b>11.8 mph</b>
Travel Speed — Fwd 4th	20.0 km/h	<b>12.4 mph</b>	20.0 km/h	<b>12.4 mph</b>
Travel Speed — Fwd 5th	5.6 km/h	<b>3.5 mph</b>	5.6 km/h	<b>3.5 mph</b>
Travel Speed — Fwd 6th	10.4 km/h	<b>6.5 mph</b>	10.4 km/h	<b>6.5 mph</b>
Travel Speed — Rev 1st	18.9 km/h	<b>11.8 mph</b>	18.9 km/h	<b>11.8 mph</b>
Travel Speed — Rev 2nd				
Travel Speed — Rev 3rd	<b>Enclosed wet single disc</b>		<b>Enclosed wet single disc</b>	
<b>Brakes:</b>	<b>Spring applied, hydraulically released</b>		<b>Spring applied, hydraulically released</b>	
Service	<b>Load sense, closed center</b>		<b>Load sense, closed center</b>	
Transmission Cooler Type	<b>Variable displacement piston pump</b>		<b>Variable displacement piston pump</b>	
<b>Hydraulic System:</b>	220 L/min	<b>58 gpm</b>	220 L/min	<b>58 gpm</b>
Type	<b>Service Refill:</b>		<b>Service Refill:</b>	
Pump Type	378 L	<b>99.8 U.S. gal</b>	378 L	<b>99.8 U.S. gal</b>
Pump Output	19 L	<b>5.0 U.S. gal</b>	19 L	<b>5.0 U.S. gal</b>
<b>Service Refill:</b>	27 L	<b>7.1 U.S. gal</b>	27 L	<b>7.1 U.S. gal</b>
Fuel Tank	57 L	<b>15.1 U.S. gal</b>	57 L	<b>15.1 U.S. gal</b>
DEF Tank*	54 L	<b>14.3 U.S. gal</b>	54 L	<b>14.3 U.S. gal</b>
Engine Oil	425 mL	<b>14.4 oz</b>	425 mL	<b>14.4 oz</b>
Cooling System	<b>Differential, Final Drive:</b>		<b>Differential, Final Drive:</b>	
Transmission, Torque Converter	Front	<b>52 L</b>	52 L	<b>13.7 U.S. gal</b>
Parking Brake	Rear	<b>52 L</b>	52 L	<b>13.7 U.S. gal</b>
Differential, Final Drive:	<b>Hydraulic System:</b>		<b>Hydraulic System:</b>	
Front	Tank	<b>65 L</b>	65 L	<b>17.2 U.S. gal</b>
Rear	Total	<b>123 L</b>	123 L	<b>32.5 U.S. gal</b>
Hydraulic System:				
Tank				
Total				

\*Tier 4 Final/Stage IV/Japan 2014 (Tier 4 Final) equipped machines only.

<b>MODEL</b>	<b>525D</b>		<b>535D</b>	
<b>Winch — Retrieval Winch:</b>				
Type	<b>Hydraulically driven</b>		<b>Hydraulically driven</b>	
Maximum Line Pull — Bare Drum	178 kN	<b>40,016 lbf</b>	178 kN	<b>40,016 lbf</b>
Maximum Line Speed	41 m/min	<b>134 ft/min</b>	41 m/min	<b>134 ft/min</b>
Drum Diameter	229 mm	<b>9"</b>	229 mm	<b>9"</b>
Drum Width	254 mm	<b>10"</b>	254 mm	<b>10"</b>
Drum Capacity:				
19.0 mm ( <b>¾ in</b> )	59 m	<b>195'0"</b>	59 m	<b>195'0"</b>
25.4 mm ( <b>1 in</b> )	26 m	<b>85'0"</b>	26 m	<b>85'0"</b>
<b>Winch — Logging Winch:</b>				
Type	<b>Hydraulically driven</b>		<b>Hydraulically driven</b>	
Maximum Line Pull — Bare Drum	178 kN	<b>40,016 lbf</b>	178 kN	<b>40,016 lbf</b>
Maximum Line Speed	85.3 m/min	<b>280 ft/min</b>	85.3 m/min	<b>280 ft/min</b>
Drum Diameter	229 mm	<b>9"</b>	229 mm	<b>9"</b>
Drum Width	254 mm	<b>10"</b>	254 mm	<b>10"</b>
Drum Capacity:				
19.0 mm ( <b>¾ in</b> )	59 m	<b>195'0"</b>	59 m	<b>195'0"</b>
25.4 mm ( <b>1 in</b> )	26 m	<b>85'0"</b>	26 m	<b>85'0"</b>
<b>MODEL</b>	<b>545D</b>		<b>555D</b>	
<b>Winch — Retrieval Winch:</b>				
Type	<b>Hydraulically driven</b>		<b>Hydraulically driven</b>	
Maximum Line Pull — Bare Drum	178 kN	<b>40,016 lbf</b>	178 kN	<b>40,016 lbf</b>
Maximum Line Speed	41 m/min	<b>134 ft/min</b>	41 m/min	<b>134 ft/min</b>
Drum Diameter	229 mm	<b>9"</b>	229 mm	<b>9"</b>
Drum Width	254 mm	<b>10"</b>	254 mm	<b>10"</b>
Drum Capacity:				
19.0 mm ( <b>¾ in</b> )	59 m	<b>195'0"</b>	59 m	<b>195'0"</b>
25.4 mm ( <b>1 in</b> )	26 m	<b>85'0"</b>	26 m	<b>85'0"</b>
<b>Winch — Logging Winch:</b>				
Type	<b>Hydraulically driven</b>		<b>Hydraulically driven</b>	
Maximum Line Pull — Bare Drum	178 kN	<b>40,016 lbf</b>	178 kN	<b>40,016 lbf</b>
Maximum Line Speed	85.3 m/min	<b>280 ft/min</b>	85.3 m/min	<b>280 ft/min</b>
Drum Diameter	229 mm	<b>9"</b>	229 mm	<b>9"</b>
Drum Width	254 mm	<b>10"</b>	254 mm	<b>10"</b>
Drum Capacity:				
19.0 mm ( <b>¾ in</b> )	59 m	<b>195'0"</b>	59 m	<b>195'0"</b>
25.4 mm ( <b>1 in</b> )	26 m	<b>85'0"</b>	26 m	<b>85'0"</b>

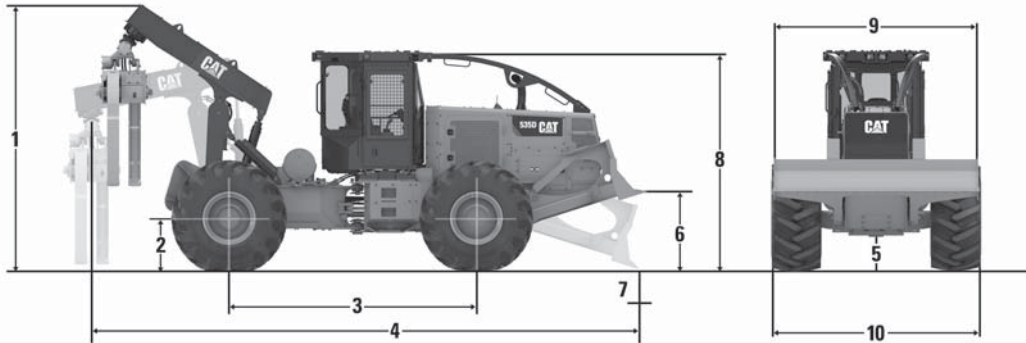

MODEL	525D	535D	545D	555D
<b>1</b> Ground Level to Top Arch/Boom*				
Cable	2785 mm <b>109.6"</b>	2785 mm <b>109.6"</b>	2785 mm <b>109.6"</b>	N/A
Single Function	3702 mm <b>145.8"</b>	3702 mm <b>145.8"</b>	N/A	N/A
Dual Function	4136 mm <b>162.8"</b>	4136 mm <b>162.8"</b>	4517 mm <b>177.8"</b>	4517 mm <b>177.8"</b>
<b>2</b> Ground Level to Axle Center Line*	843 mm <b>33.2"</b>	843 mm <b>33.2"</b>	843 mm <b>33.2"</b>	843 mm <b>33.2"</b>
<b>3</b> Wheelbase	3652 mm <b>143.8"</b>	3796 mm <b>149.4"</b>	3940 mm <b>155.1"</b>	4083 mm <b>160.7"</b>
<b>4</b> Overall Length				
Cable	7297 mm <b>287.3"</b>	7441 mm <b>292.9"</b>	7585 mm <b>298.6"</b>	N/A
Single Function	9051 mm <b>356.3"</b>	9195 mm <b>361.9"</b>	N/A	N/A
Dual Function	8322 mm <b>327.6"</b>	8465 mm <b>333.3"</b>	8827 mm <b>347.5"</b>	9007 mm <b>354.6"</b>
<b>5</b> Ground Clearance*	550 mm <b>21.7"</b>	550 mm <b>21.7"</b>	550 mm <b>21.7"</b>	550 mm <b>21.7"</b>
<b>6</b> Blade Lift Height*	1426 mm <b>56.1"</b>	1426 mm <b>56.1"</b>	1426 mm <b>56.1"</b>	1426 mm <b>56.1"</b>
<b>7</b> Blade Dig Depth*	529 mm <b>20.8"</b>	529 mm <b>20.8"</b>	529 mm <b>20.8"</b>	529 mm <b>20.8"</b>
<b>8</b> Height to Top of Cab*	3386 mm <b>133.3"</b>	3386 mm <b>133.3"</b>	3386 mm <b>133.3"</b>	3386 mm <b>133.3"</b>
<b>9</b> Blade Width				
Standard	2678 mm <b>105.4"</b>	2678 mm <b>105.4"</b>	2678 mm <b>105.4"</b>	2678 mm <b>105.4"</b>
Wide	3138 mm <b>123.5"</b>	3138 mm <b>123.5"</b>	3138 mm <b>123.5"</b>	3138 mm <b>123.5"</b>
<b>10</b> Overall Width				
30.5L-32 NOAW	3216 mm <b>126.6"</b>	3216 mm <b>126.6"</b>	3216 mm <b>126.6"</b>	3216 mm <b>126.6"</b>
30.5L-32 2X Ring	3216 mm <b>126.6"</b>	3216 mm <b>126.6"</b>	3216 mm <b>126.6"</b>	3216 mm <b>126.6"</b>
30.5L-32	3386 mm <b>133.3"</b>	3386 mm <b>133.3"</b>	3386 mm <b>133.3"</b>	3386 mm <b>133.3"</b>
35.5L-32 NOAW	3533 mm <b>139.1"</b>	3533 mm <b>139.1"</b>	3533 mm <b>139.1"</b>	3533 mm <b>139.1"</b>
35.5L-32	3703 mm <b>145.8"</b>	3703 mm <b>145.8"</b>	3703 mm <b>145.8"</b>	3703 mm <b>145.8"</b>
<b>11</b> Weight**				
Cable	18 935 kg <b>41,745 lb</b>	19 095 kg <b>42,097 lb</b>	19 352 kg <b>42,665 lb</b>	N/A
Single Function	20 065 kg <b>44,235 lb</b>	20 305 kg <b>44,766 lb</b>	N/A	N/A
Dual Function	20 525 kg <b>45,249 lb</b>	20 766 kg <b>45,780 lb</b>	21 190 kg <b>46,717 lb</b>	21 540 kg <b>47,488 lb</b>

\*All heights based on 30.5L-32 tire, add 61 mm (2.4") for 35.5L-32 tires for dimensions 1, 2, 5, 6, and 8, subtract 61 mm (2.4") for 35.5L-32 tires for dimension 7.  
 \*\*Base Weight: 30.5L-32 20PR tires, grapple fenders, retrieval winch, water tank, wide blade.  
 Deduct 227 kg (500 lb) for machines equipped with the Tier 3/Stage IIIA/Japan 2006 (Tier 3) equivalent Cat C7.1 ACERT™ engine.  
 Deduct 2808 kg (6191 lb) for no tires; add 49 kg (108 lb) for 30.5L-32 26 PLY tires (required for 555D), 296 kg (653 lb) for 30.5L-32 2X ring, 628 kg (1385 lb) for 35.5L-32 20 PLY tires, 733 kg (1616 lb) for 35.5L-32 24 PLY tires.  
 Deduct 97 kg (215 lb) for standard width blade.  
 Deduct 239 kg (526 lb) for no grapple fenders (not applicable for cable configuration).  
 Deduct 786 kg (1733 lb) for no retrieval winch; add 66 kg (146 lb) for logging winch (not applicable for cable configuration).



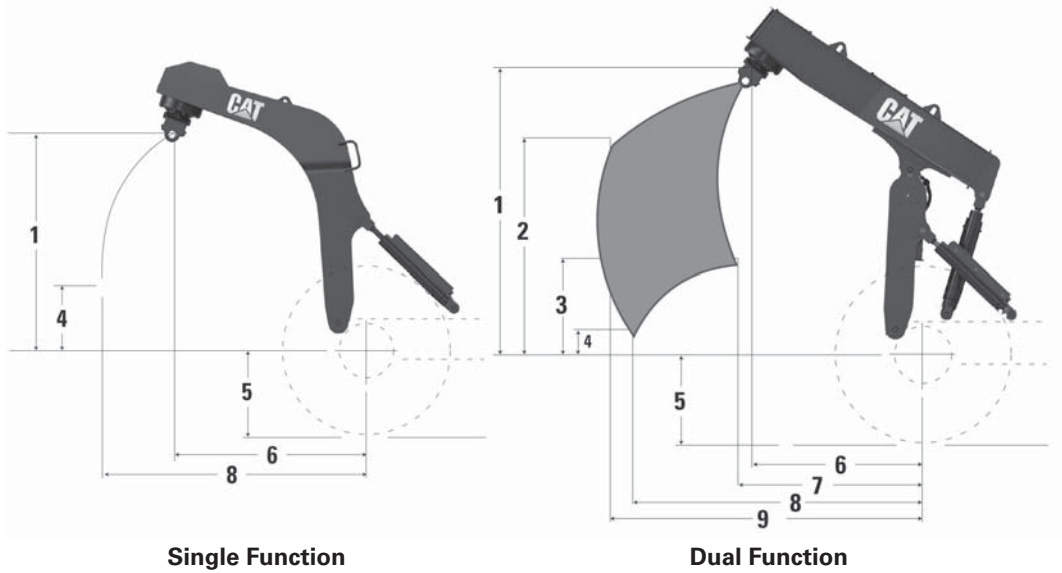

**Single Function**

**Dual Function**

MODEL	525D				535D			
	Single Function		Dual Function		Single Function		Dual Function	
<b>1</b> Lift Height, Retracted	2208 mm	<b>86.9"</b>	2652 mm	<b>104.4"</b>	2208 mm	<b>86.9"</b>	2652 mm	<b>104.4"</b>
<b>2</b> Lift Height, Furthest	N/A		1928 mm	<b>75.9"</b>	N/A		1928 mm	<b>75.9"</b>
<b>3</b> Lift Lowest, Retracted	N/A		918 mm	<b>36.1"</b>	N/A		918 mm	<b>36.1"</b>
<b>4</b> Lift Lowest, Furthest	596 mm	<b>23.5"</b>	280 mm	<b>11.0"</b>	596 mm	<b>23.5"</b>	280 mm	<b>11.0"</b>
<b>5</b> Ground Level to Axle Center Line*	843 mm	<b>33.2"</b>	843 mm	<b>33.2"</b>	843 mm	<b>33.2"</b>	843 mm	<b>33.2"</b>
<b>6</b> Reach Highest, Retracted	1786 mm	<b>70.3"</b>	1643 mm	<b>64.7"</b>	1786 mm	<b>70.3"</b>	1643 mm	<b>64.7"</b>
<b>7</b> Reach Lowest, Retracted	N/A		1541 mm	<b>60.7"</b>	N/A		1541 mm	<b>60.7"</b>
<b>8</b> Reach Lowest, Furthest	2668 mm	<b>105.0"</b>	2518 mm	<b>99.1"</b>	2668 mm	<b>105.0"</b>	2518 mm	<b>99.1"</b>
<b>9</b> Reach Highest, Furthest	N/A		2917 mm	<b>114.8"</b>	N/A		2917 mm	<b>114.8"</b>

\*Add 61 mm (2.4") for 35.5-32 tires.

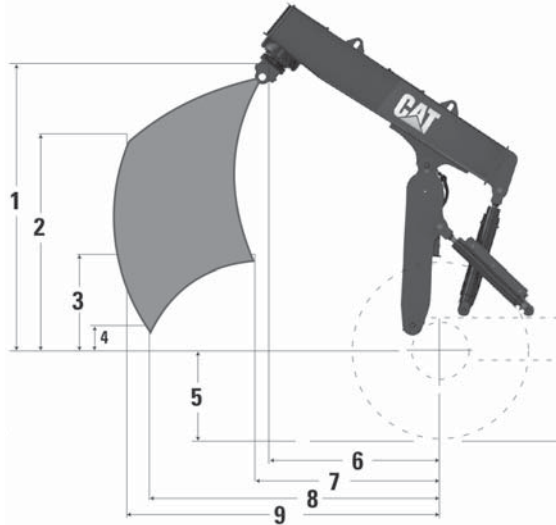

Dual Function

MODEL	545D		555D	
	Dual Function		Dual Function	
<b>1</b> Lift Height, Retracted	3005 mm	<b>118.3"</b>	3005 mm	<b>118.3"</b>
<b>2</b> Lift Height, Furthest	2200 mm	<b>86.6"</b>	2200 mm	<b>86.6"</b>
<b>3</b> Lift Lowest, Retracted	1125 mm	<b>44.3"</b>	1125 mm	<b>44.3"</b>
<b>4</b> Lift Lowest, Furthest	379 mm	<b>14.9"</b>	379 mm	<b>14.9"</b>
<b>5</b> Ground Level to Axle Center Line*	843 mm	<b>33.2"</b>	843 mm	<b>33.2"</b>
<b>6</b> Reach Highest, Retracted	1626 mm	<b>64.0"</b>	1626 mm	<b>64.0"</b>
<b>7</b> Reach Lowest, Retracted	1883 mm	<b>74.1"</b>	1883 mm	<b>74.1"</b>
<b>8</b> Reach Lowest, Furthest	2863 mm	<b>112.7"</b>	2863 mm	<b>112.7"</b>
<b>9</b> Reach Highest, Furthest	3007 mm	<b>118.4"</b>	3007 mm	<b>118.4"</b>

\*Add 61 mm (2.4") for 35.5-32 tires.

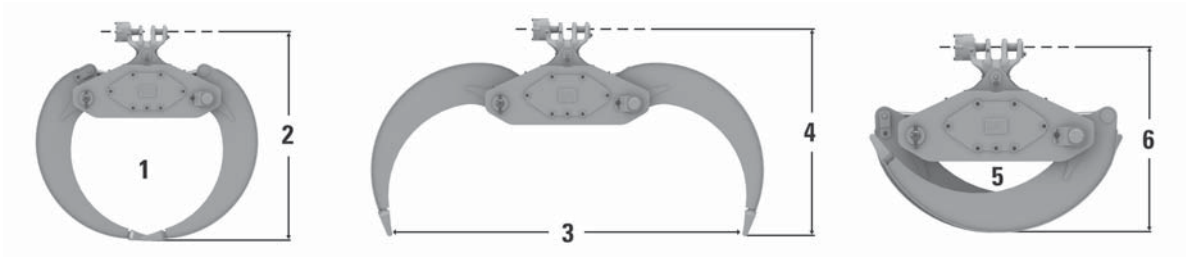

MODEL	525D		535D		545D		555D	
<b>1</b> Grapple Capacity	1.34 m <sup>2</sup>	<b>14.4 ft<sup>2</sup></b>	1.54 m <sup>2</sup>	<b>16.6 ft<sup>2</sup></b>	1.77 m <sup>2</sup>	<b>19.0 ft<sup>2</sup></b>	2.04 m <sup>2</sup>	<b>22.0 ft<sup>2</sup></b>
<b>2</b> Tip to Tip Height	2083 mm	<b>82.0"</b>	2108 mm	<b>83.0"</b>	2159 mm	<b>85.0"</b>	2367 mm	<b>93.19"</b>
<b>3</b> Tong Opening	3205 mm	<b>126.2"</b>	3226 mm	<b>127.0"</b>	3429 mm	<b>135.0"</b>	3652 mm	<b>143.78"</b>
<b>4</b> Fully Open Height	1811 mm	<b>71.3"</b>	1905 mm	<b>75.0"</b>	1880 mm	<b>74.0"</b>	1998 mm	<b>78.66"</b>
<b>5</b> Minimum Stem Diameter	176 mm	<b>6.9"</b>	183 mm	<b>7.2"</b>	241 mm	<b>9.5"</b>	305 mm	<b>12.01"</b>
<b>6</b> Fully Closed Height	1382 mm	<b>54.4"</b>	1371 mm	<b>54.0"</b>	1473 mm	<b>58.0"</b>	1577 mm	<b>62.09"</b>

## Introduction

The Cat 527 Skidder is designed and built specifically for log skidding applications. The 527's extended track roller frame and weight-forward bias make it well suited for mountainous and soft underfoot logging operations. The skidder's ergonomic and spacious operator's environment allow for increased comfort and production. The 527's standard forestry guarding and undercarriage design ensure the durability required in logging applications. Both Cable and Swing-boom Grapple configurations are provided to suit a wide range of skidding applications.

## Features 527:

- **Field proven Cat 3304 diesel engine** sets the industry standard for reliability and durability, delivering high horsepower for more drawbar pull, improved skidding performance and ease of operation.
- **Large, heavy duty torque converter**, reduces the tendency for track-to-ground slip, reduces the need for up and downshifting and protects power train components contributing to longer component life.
- **3 speed planetary powershift transmission** works best in high-pull applications and is well suited for large load and steep terrain skidding.
- **Heavy-duty track roller frame** extended to the rear significantly improves traction capability under heavy loads and uphill skidding applications.
- **Wide gauge and long track roller frames** provide outstanding sidehill stability.
- **Improved flotation** — More track on the ground distributes tractor weight and propulsion forces over a much larger area than conventional track skidders. This improves flotation capabilities, gradeability and significantly reduces soil impact.
- **Load sensing hydraulic system** — Variable displacement pressure compensating hydraulic system provides reduced power requirements when there is not hydraulic demand, significantly reduced heat generation, and improving fuel efficiency.
- **Auto-grab feature** — provides constant grapple tong pressure without continuous hydraulic pump demand.
- **Superior component durability** — Final drives are raised above the work area, isolating the power train from ground impact shock and abrasive materials.
- **Excellent ground clearance** — no diagonal braces allow the skidder to pass over stumps and debris, reduces maneuvering for reduced cycle times and minimizes soil impact.
- **Smooth belly pans** — Less likely to hang up in mud and debris in soft ground or swamp logging applications.
- **Easy and comfortable operating environment** — The seat is angled and controls are easily reached to reduce operator fatigue and increase productivity. Optional enclosed ROPS/FOPS cab allows excellent front and rear viewing, and is pressurized for sound level reduction.
- **Single lever** grapple control and blade control.
- **Less service time** — Major components are made as modules and most can be removed without removing others, and ground-level access provides convenient servicing to most filters and lube points.
- **Cable and Swing Boom** configurations provide the versatility needed to match the skidder to a wide variety of skidding applications.

<b>MODEL</b>	<b>527 Cable</b>		<b>527 Grapple</b>	
Gross Power (ISO 14396)	124 kW	<b>166 hp</b>	124 kW	<b>166 hp</b>
Operating Weight*	18 720 kg	<b>41,270 lb</b>	21 900 kg	<b>48,281 lb</b>
Engine Model	<b>3304 DIT</b>		<b>3304 DIT</b>	
Rated Engine RPM	<b>2200</b>		<b>2200</b>	
Bore	120.65 mm	<b>4.75"</b>	120.65 mm	<b>4.75"</b>
Stroke	152.4 mm	<b>6"</b>	152.4 mm	<b>6"</b>
Displacement	7 L	<b>425 in<sup>3</sup></b>	7 L	<b>425 in<sup>3</sup></b>
No. of Cylinders	<b>4</b>		<b>4</b>	
Speeds Forward:				
1st	3.7 km/h	<b>2.3 mph</b>	3.7 km/h	<b>2.3 mph</b>
2nd	6.6 km/h	<b>4.1 mph</b>	6.6 km/h	<b>4.1 mph</b>
3rd	11.5 km/h	<b>7.1 mph</b>	11.5 km/h	<b>7.1 mph</b>
Speeds Reverse:				
1st	4.6 km/h	<b>2.8 mph</b>	4.6 km/h	<b>2.8 mph</b>
2nd	8.3 km/h	<b>5.1 mph</b>	8.3 km/h	<b>5.1 mph</b>
3rd	14.6 km/h	<b>9.0 mph</b>	14.6 km/h	<b>9.0 mph</b>
Track Roller Frame	<b>7</b>		<b>8</b>	
Width of Standard Track Shoe	560 mm	<b>22"</b>	760 mm	<b>30"</b>
Track Gauge	2160 mm	<b>85"</b>	2160 mm	<b>85"</b>
General Dimensions:				
Height (To Top of ROPS)	3298 mm	<b>129.8"</b>	3298 mm	<b>129.8"</b>
Overall Length:				
With Blade and Winch	5224 mm	<b>205.67"</b>	—	
With Blade and Maximum Boom Reach	—		8166 mm	<b>321.5"</b>
With Blade and Minimum Boom Reach	—		6137 mm	<b>241.6"</b>
Width (without Trunnion)	2720 mm	<b>107"</b>	2720 mm	<b>107"</b>
Ground Clearance	711.2 mm	<b>28"</b>	711.2 mm	<b>28"</b>
Capacity:				
Fuel Tank	284 L	<b>75 U.S. gal</b>	284 L	<b>75 U.S. gal</b>

\*All models include coolant, lubricants, full fuel tank, and operator.

527 Cable includes lubricants, coolant, ROPS canopy, 100% fuel, operator, 5P blade, open cab, and towing winch.

527 Grapple includes lubricants, coolant, ROPS canopy, 100% fuel, operator, 5P blade, track roller guard, 760 mm (30") tri-link track, swing grapple, 2.54 m (100") sorting head, and enclosed cab.

\*\*With 22 mm (0.88") cable.

## Shoe Selection and Ground Pressure

MODEL	527 (7-roller track frame)		527 (8-roller track frame)	
	Number of Shoes (each side)	41		43
Width of Shoes	560 mm	22"	—	
	610 mm	24"	—	
	760 mm	30"	760 mm	30"
Length of Track on Ground	2846 mm	112"	3061 mm	121"
Track Gauge	2160 mm	85"	2160 mm	85"
Ground Contact Area with:				
560 mm (22") Shoes	3.18 m <sup>2</sup>	4928 in <sup>2</sup>	—	
610 mm (24") Shoes	3.47 m <sup>2</sup>	5376 in <sup>2</sup>	—	
760 mm (30") Tri-link	4.33 m <sup>2</sup>	6705 in <sup>2</sup>	4.65 m <sup>2</sup>	7208 in <sup>2</sup>
Ground Pressure (Grapple):				
760 mm (30") Tri-link	—		0.47 kg/cm <sup>2</sup>	6.70 psi
Ground Pressure (Cable):				
560 mm (22") Shoes	0.59 kg/cm <sup>2</sup>	8.37 psi	—	
610 mm (24") Shoes	0.54 kg/cm <sup>2</sup>	7.74 psi	—	
760 mm (30") Shoes	0.46 kg/cm <sup>2</sup>	6.74 psi	—	

5

## Winch Specifications

MODEL	527 Cable	
Maximum Line Pull	93 822 N·m	69,200 lb
Maximum Line Speed	43.6 m/min	143 fpm
Drum Capacity:		
Recommended	122 m	400'0"
Cable Size:		
Recommended	19 mm	0.75"
Drum Diameter	254 mm	10.0"
Drum Width	330 mm	13.0"
Weight	1497 kg	3300 lb

## Blade Specifications

MODEL	5P-PAT		527 PAT	
Blade Width — Straight	3272 mm	128.82"	3460 mm	136.22"
Blade Height	1200 mm	47.24"	922 mm	36.30"
Blade Capacity*	3.77 m <sup>3</sup>	4.93 yd <sup>3</sup>	2.35 m <sup>3</sup>	3.07 yd <sup>3</sup>

\*Blade capacity calculated per ISO 9246 Engineering Standard for Determination of Dozer Volume Capacity.

**MACHINE DIMENSIONS** (All dimensions are approximate.)

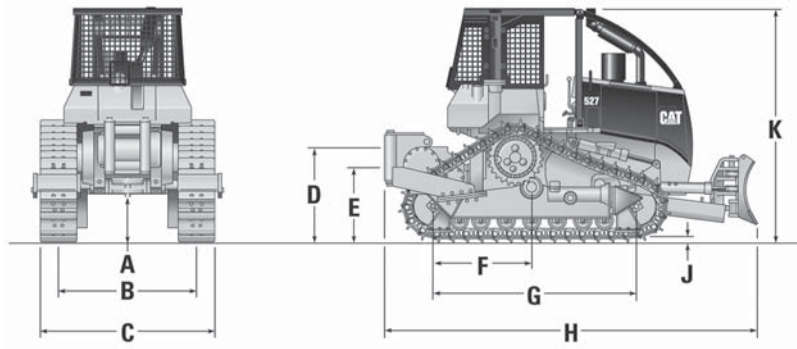

**MODEL**

**527 Cable**

MODEL	527 Cable	
<b>A</b> Ground Clearance	712 mm	28"
<b>B</b> Track Gauge	2160 mm	85"
<b>C</b> Shipping Width*	2720 mm	107"
<b>D</b> Height to Top of Drum	1339 mm	53"
<b>E</b> Height to Center of Drum	1048 mm	41"
<b>F</b> Pivot Shaft to Rear Idler**	1380 mm	54"
<b>G</b> Length of Track on Ground**	2846 mm	112"
<b>H</b> Shipping Length	5224 mm	205.67"
<b>J</b> Grouser Height	65 mm	2.6"
<b>K</b> Shipping Height	3298 mm	129.8"

\*With 560 mm (22") Track Shoes.

\*\*With 7-Roller Track Frame.

**MACHINE DIMENSIONS** (All dimensions are approximate.)

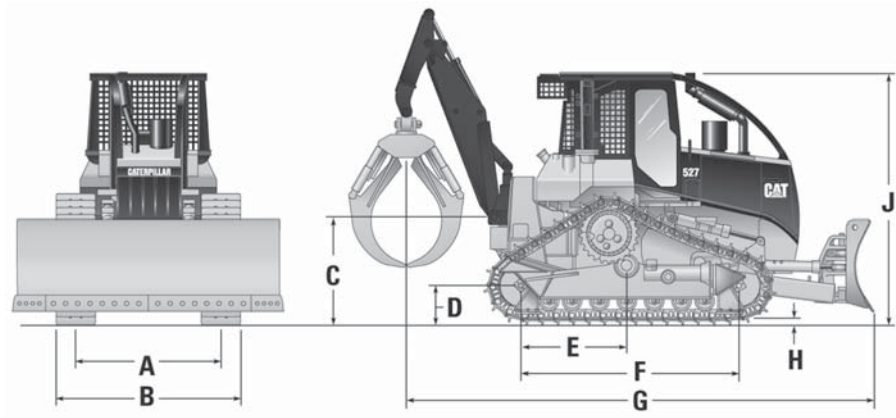

**MODEL**

**527 Swing Boom**

<b>A</b> Track Gauge	2160 mm	85"
<b>B</b> Shipping Width*	3020 mm	118.9"
<b>C</b> Height to Swing Boom Pivot Pin	1408 mm	55"
<b>D</b> Height to Center of Idlers	452 mm	18"
<b>E</b> Pivot Shaft to Rear Idler**	1595 mm	62.8"
<b>F</b> Length of Track on Ground**	3061 mm	121"
<b>G</b> Overall Length — Boom Retracted	6137 mm	241.6"
Overall Length — Boom Extended (not shown)	8166 mm	321.5"
<b>H</b> Grouser Height	65 mm	2.6"
<b>J</b> Shipping Height	3298 mm	129.8"

\*With 760 mm (30") Track Shoes.

\*\*With 8-Roller Track Frame.



527 SKIDDER

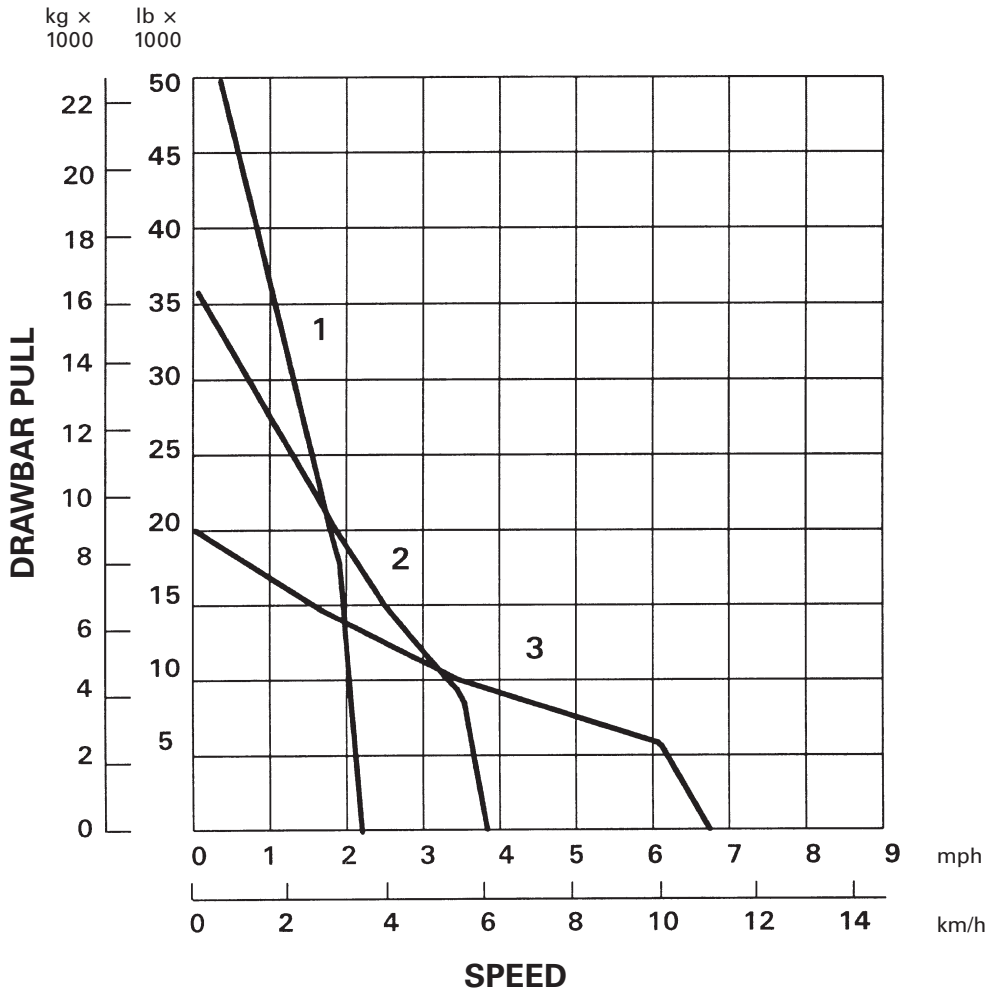

- KEY
- 1 – 1st Gear
  - 2 – 2nd Gear
  - 3 – 3rd Gear

**NOTE:** Usable pull will depend upon weight and traction of equipped tractor.

**BOOM AND GRAPPLES**

The following contains information on some of the available models, which are presented here to suggest a range of grapple possibilities.

**Reach (A, B)** — The horizontal distance from the vertical center of the rear idler to the vertical center of the grapple fore and aft pivot.

- A) With the grapple in its lowest fully extended position.
- B) With the grapple in its highest fully retracted position.

**Lift (C, D, E)** — The vertical distance from the ground to the center of the grapple fore and aft pivot.

- C) With the grapple in its highest fully extended position.
- D) With the grapple in its highest fully retracted position.
- E) With the grapple in its lowest fully extended position.

**Maximum Grapple Opening (K)** — The horizontal distance between the tips of the grapple arms when grapple is fully open.

**Area of Opening (L)** — The available area with grapple in tips together position.

**Minimum Log Size (M)** — The smallest diameter which the grapple can close.

**Grapple Length (N, O, P)** — The distance from the grapple fore and aft pivot to tips of grapple arms.

- N) With grapple fully open.
- O) With grapple in tips together position.
- P) With grapple fully closed.

**Bunching Grapple**

- Used for 305 mm (12") or smaller diameter trees.
- Designed to gather bundle of stems and maximize grapple loads.

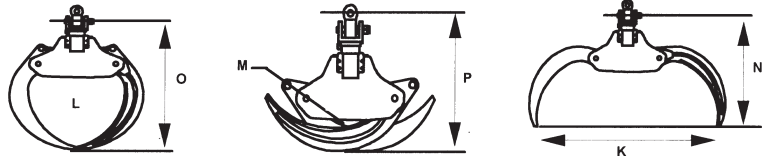

Grapples for 527	K	L	M	N	O	P
2.79 m (110") Bunching	2794 mm 110"	0.93 m <sup>2</sup> 10 ft <sup>2</sup>	76 mm 3"	1780 mm 70"	2020 mm 79.5"	1360 mm 53.5"

**Swing-boom**

- Ability to reach and lift over the side to collect scattered logs.
- Has decking and loading capability.
- Excellent reach to the rear and side for maximum skidder versatility.
- Suitable for hard to reach timber on steep slopes, soft ground, or selection harvest and thinning.
- Reduces cycle times by reducing the amount of maneuvering of the skidder to reach logs.

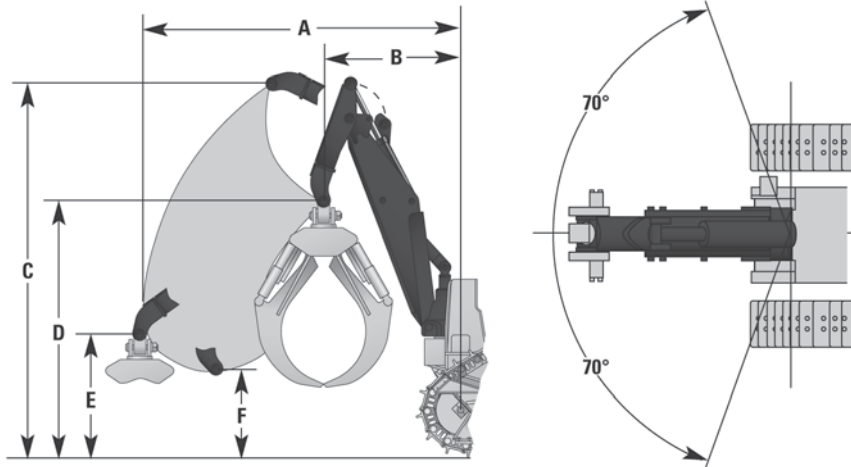

<b>Swing-boom</b>		<b>A</b>	<b>B</b>	<b>C</b>	<b>D</b>	<b>E</b>	<b>F</b>
527	mm	3329	1301	4084	2792	1358	933.5
	in	131.1	51.2	160.8	109.9	53.5	36.8

**Sustainability:**

- **Major structures and components** are built to be rebuilt, reducing waste and replacement costs.
- **ACERT Technology** reduces engine emissions at point of combustion with less moving parts for lower operating costs.

**564/574 Features:**

- **Field-proven Cat engines with ACERT Technology**, along with a torque converter power shift transmission. The engines meet Tier 3/Stage IIIA/Japan 2006 (Tier 3) equivalent emission standards. Flex engines are available for HRC regions.
- **Large high visibility cab** with scratch resistant 1.27 cm (0.5 in) tinted polycarbonate windows and side windows with escape.

- **Hydraulic tilt** gives complete under cab service access.
- **Extra heavy frame** with full 40 degree articulation for tight turning.
- **Purpose-built blade** with wear resistant front cutting edge.
- **Rear mounted loader** with durable rack and pinion swing system.
- **Full load high reach boom.**
- **250 degree rotation.**
- **European style butt-bypass clam** built with high strength steel dampener.

MODEL	564 (6-wheel)		574 (8-wheel)	
Gross Power (ISO 14396)	129 kW	173 hp	129 kW	173 hp
Operating Weight	16 330 kg	36,000 lb	17 237 kg	38,000 lb
Engine Model	C6.6 ACERT		C6.6 ACERT	
Emission Standards	Tier 3/Stage IIIA/ Japan 2006 (Tier 3) equivalent		Tier 3/Stage IIIA/ Japan 2006 (Tier 3) equivalent	
Maximum Forward Speed	23.3 km/h	14.5 mph	23.3 km/h	14.5 mph
Loader Reach	6.9 m	22'9"	6.9 m	22'9"
Load Capacity	13 608 kg	30,000 lb	14 525 kg	32,000 lb
Fuel Capacity	178 L	47 U.S. gal	178 L	47 U.S. gal
Transmission	Electric Powershift		Electric Powershift	
General Dimensions:				
Wheelbase	5334 mm	210"	5334 mm	210"
Ground Clearance	579 mm	22.8"	579 mm	22.8"

**Sustainability:**

- **Major structures and components** are built to be rebuilt, reducing waste and replacement costs.
- **ACERT Technology** reduces engine emissions at point of combustion with less moving parts for lower operating costs.
- **Speed modulated hydraulically driven cooling fan** for decreased power requirements resulting in reduced fuel consumption.
- **1800 RPM engine** for reduced engine speeds to provide increased fuel economy.

**584/584HD Features:**

- **Cat C7 ACERT engine** with 1800 RPM rating and excellent torque in the 1400 to 1600 RPM range for increased fuel efficiency. The engines meet Tier 3/ Stage IIIA/Japan 2006 (Tier 3) equivalent emission standards suitable for LRC regions.
- **Enlarged hydraulic cooling capacity** to provide high heat rejection capability for extended component life.
- **Hydraulic driven cooling fan** with speed modulation for reduced fuel consumption and maintaining optimal system temperatures for better component performance.

- **Hydrostatic drive system** for infinitely variable speed at peak power and dynamic braking for steep terrain.
- **8.5C drive line components** provide superior strength and service life for reduced maintenance costs.
- **Robust front and rear frame structures** provide the ability to rebuild/relife to reduce overall ownership costs and increase resale values.
- **Heavy duty cast articulation and large oscillation bearing** designed to provide a long service life.
- **Ergonomic cab** with automatic temperature control, air suspension seat, storage compartments, and low effort joy stick controls.
- **Drop down side window** design for enhanced visibility to the work area close to the machine and in front of all wheels.
- **Front entry door** provides easy access off of a hydraulic lift stairway and platform.
- **Forward tilting engine hood and hydraulic tilt cab** for easy service access.

<b>MODEL</b>	<b>584 (6-wheel)</b>		<b>584HD (8-wheel)</b>	
Gross Power (ISO 14396)	204 kW	<b>274 hp</b>	204 kW	<b>274 hp</b>
Operating Weight	20 230 kg	<b>44,600 lb</b>	23 088 kg	<b>50,900 lb</b>
Engine Model	<b>C7 ACERT</b>		<b>C7 ACERT</b>	
Emission Standards	<b>Tier 3/Stage IIIA/ Japan 2006 (Tier 3) equivalent</b>		<b>Tier 3/Stage IIIA/ Japan 2006 (Tier 3) equivalent</b>	
Maximum Tractive Force	210 kN	<b>47,169 lb-f</b>	226 kN	<b>50,864 lb-f</b>
Maximum Speed	22.5 km/h	<b>14.0 mph</b>	20.9 km/h	<b>13.0 mph</b>
STD Loader Reach	8.0 m	<b>26.25 ft</b>	8.0 m	<b>26.25 ft</b>
Loader Lifting Torque (gross)	159 kN·m	<b>111,975 lb-ft</b>	159 kN·m	<b>111,975 lb-ft</b>
Load Capacity	18 000 kg	<b>39,683 lb</b>	20 000 kg	<b>44,092 lb</b>
Fuel Capacity	255 L	<b>67.3 U.S. gal</b>	255 L	<b>67.3 U.S. gal</b>
Transmission	<b>2 speed hydrostatic</b>		<b>2 speed hydrostatic</b>	
General Dimensions:				
Wheelbase	6096 mm	<b>240"</b>	6096 mm	<b>240"</b>
Bogie Spread (center to center)	1690 mm	<b>66.5"</b>	1690 mm	<b>66.5"</b>
Ground Clearance	692 mm	<b>27.3"</b>	692 mm	<b>27.3"</b>

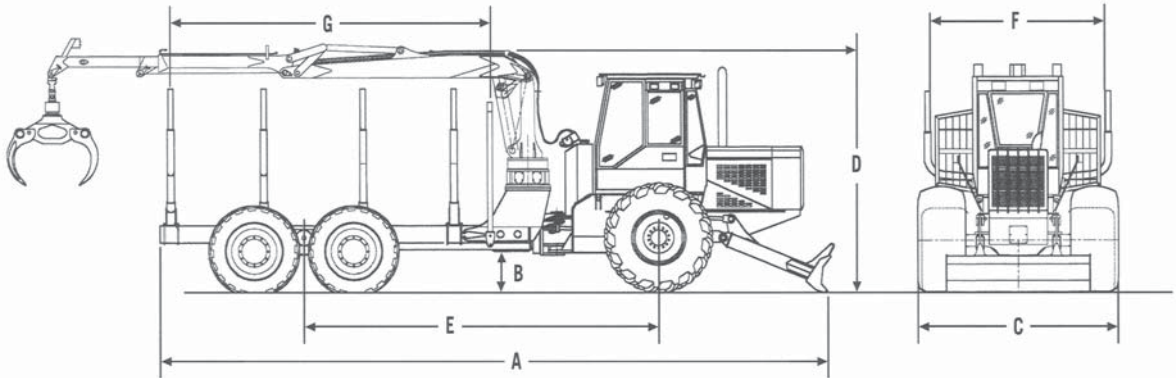

**MODEL**

**564 (6-wheel)**

**574 (8-wheel)**

MODEL	564 (6-wheel)		574 (8-wheel)	
<b>A</b> Length with:				
4.88 m (16') Load Deck	10 210 mm	402"	10 210 mm	402"
5.64 m (18.5') Load Deck	10 970 mm	432"	10 970 mm	432"
<b>B</b> Ground Clearance	579 mm	22.8"	579 mm	22.8"
<b>C</b> Width with Standard Tires	2997 mm	118"	3048 mm	120"
<b>D</b> Transport Height	3581 mm	141"	3581 mm	141"
<b>E</b> Wheelbase with:				
4.88 m (16') Load Deck	5334 mm	210"	5334 mm	210"
5.64 m (18.5') Load Deck	5715 mm	225"	5715 mm	225"
<b>F</b> Load Stake Width (Inside)	2591 mm	102"	2591 mm	102"
<b>G</b> Length of Standard Wood Bunk	4880 mm	16'	4880 mm	16'
Optional Length 1	5640 mm	18.5'	5640 mm	18.5'
Optional Length 2		—		—

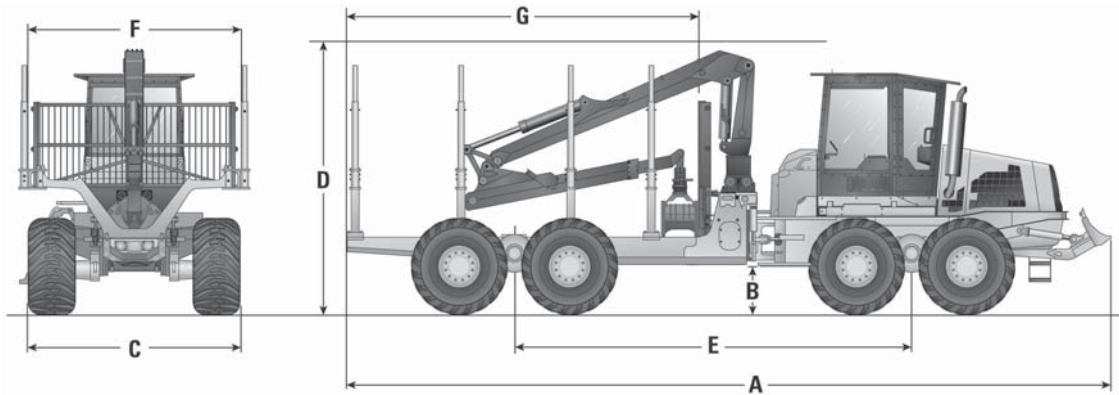

<b>MODEL</b>	<b>584 (6-wheel)</b>		<b>584HD (8-wheel)</b>	
<b>A</b> Length with Blade	11 755 mm	<b>463"</b>	11 755 mm	<b>463"</b>
<b>B</b> Ground Clearance	692 mm	<b>27.3"</b>	692 mm	<b>27.3"</b>
<b>C</b> Width with Standard Tires	3180 mm	<b>125.2"</b>	3180 mm	<b>125.2"</b>
<b>D</b> Transport Height	4163 mm	<b>163.9"</b>	4163 mm	<b>163.9"</b>
<b>E</b> Wheelbase	6096 mm	<b>240"</b>	6096 mm	<b>240"</b>
<b>F</b> Load Stake Width (Inside) with:				
Standard Bunk	2769 mm	<b>109"</b>	2769 mm	<b>109"</b>
Optional Bunk	3264 mm	<b>128.5"</b>	3264 mm	<b>128.5"</b>
<b>G</b> Length of Wood Bunk	5410 mm	<b>213"</b>	5410 mm	<b>213"</b>

**Lift Capacities**

	3700	2770	2210	1840	1570	1360	kg
	8157	6107	4872	4057	3461	2998	lb
	3	4	5	6	7	8	m
	9'10"	13'1"	16'5"	19'8"	23'0"	26'3"	ft/in

## Introduction

Cat forestry machines are specifically designed for tough forest work. Each model uses purpose built booms, sticks and grapples designed by Caterpillar for maximum performance and durability.

The following information provides features, specifications, dimensions, working ranges and major component weights for the forest machines.

## Features

### 320D Series 2 FM/320D Series 2 FM LL

- **Cat C7.1 ACERT engine** provides power, low emissions, outstanding reliability, and maximizes fuel economy. Meets Tier 3/Stage IIIA/Japan 2006 (Tier 3) equivalent emission standards.
- **Various configurations** for demanding applications including harvester, log loader, slasher, road builder, thumb, grapple saw, AEM delimeter carrier and processor.
- **Rugged undercarriage design and proven structural components** provide outstanding durability.
- **Track roller frames** are robot-welded and pressed formed, pentagonal units to deliver exceptional strength and service life.
- **Undercarriage** — Forestry machine configuration options allow you to choose the right machine for your application.
- **Operator station** — Redesigned interior layout maximizes operator space, provides exceptional comfort and reduces operator fatigue.
- **Serviceability** — Longer service intervals and easier maintenance result in better machine availability and lower costs.

### 538/538 LL

- **Cat C7.1 ACERT engine** provides exceptional fuel efficiency while delivering maximum power for this machine side class and meeting Tier 4 Final/Stage IV/Japan 2014 (Tier 4 Final) emission standards.
- **Optimized hydraulics** minimize losses due to inefficiencies through component design, component layout and finely tuned machine and work tool parameters.
- **Performance** is enhanced by 18% more swing torque than previous model that helps maximize work site efficiency.
- **Rugged frame designs** are purpose built for forest applications; these include reinforcements to the upper frame, heavy duty doors and guarding, rugged swing bearing, reinforced carbody and roller frames that help protect your investment.
- **Undercarriage** updates include 203 mm (8 in) wider undercarriage than previous model and 203 mm (8 in) pitch 329 HEX PPR2 track; roller frames include eight rollers total.
- **Engineered reliability** is provided through the use of proven Cat components and increased cooling capacity.
- **Diverse machine configurations** are available to meet the many applications of today's forest machines; these include front omission, road builder, rotate grapple, processor, under/under, over/under, powerclam, and material handler options.
- **Operator station** consists of updated seat with heated and ventilated functionality along with a new improved LCD display that is 40% larger and includes four times the screen resolution; LED lights are standard on the machine.
- **Diverse work tool options** include integrated SATCO processing heads and GLL grapples; both deliver high performance and reliability in severe logging applications.



### 324D FM/324D FM LL/325D FM/325D FM LL

- **Cat C7 ACERT engine** provides exceptional power and fuel efficiency. Meets Tier 3/Stage IIIA/Japan 2006 (Tier 3) equivalent emission standards.
- **Attachments** — Factory installed log loader fronts with live heel and Cat grapples; harvester, road builder and butt-n-top fronts; AEM delimeter carrier options help meet diverse forest applications.
- **Cat GLL forestry grapples**, built with high-grade steel throughout the grapple, matched with Cat Forest Machines provide high performance and reliability in logging applications.
- **Rugged main frame design** is purpose-built for forest applications with reinforced carbody, rugged swing bearing, heavy doors and extra guarding.
- **Undercarriage** — Both 324D FM and 325D FM feature new lowers with heavier undercarriage components, 9 roller track frames, and improved machine stability.
- **Operator station** — Interior layout maximizes operator space and provides exceptional comfort. Cab has excellent sightlines to the work area.
- **Serviceability** — Simplified service and maintenance, and electronic diagnostics help save time, money and increase productivity.

### 558 LL

- **Cat C7.1 ACERT engine** provides exceptional fuel efficiency while delivering maximum power for this machine side class and meeting Tier 4 Final/Stage IV/Japan 2014 (Tier 4 Final) emission standards.
- **Optimized hydraulics** minimize losses due to inefficiencies through component design, component layout and finely tuned machine and work tool parameters.
- **Performance** is enhanced by 25% more swing torque than previous model that helps maximize work site efficiency.
- **Rugged frame designs** are purpose built for forest applications; these include reinforcements to the upper frame, heavy duty doors and guarding, rugged swing bearing, reinforced carbody and roller frames that help protect your investment.
- **Undercarriage** includes roller frames that deliver nine rollers for needed stability and to minimize point loading; 216 mm (8.5 in) pitch 349 HEX track are used for durability.
- **Engineered reliability** is provided through the use of proven Cat components and increased cooling capacity.
- **Diverse machine configurations** are available to meet the many applications of todays forest machines; these include under/under, over/under, processor, power-clam, and material handler options.
- **Operator station** consists of updated seat with heated and ventilated functionality along with a new improved LCD display that is 40% larger and includes four times the screen resolution; LED lights are standard on the machine.
- **Diverse work tool options** include integrated SATCO processing heads and GLL grapples; both deliver high performance and reliability in severe logging applications.

**568/568 LL**

- **Cat C9.3 ACERT engine** provides exceptional power and fuel efficiency, meeting Tier 4 Interim/Stage IIIB/ Japan 2011 (Tier 4 Interim) equivalent emission standards.
- **Attachments** — Factory installed log loader fronts with live heel and Cat grapples; harvester, road builder and butt-n-top fronts; help meet diverse forestry applications.
- **Cat GLL forestry grapples**, built with high-grade steel throughout the grapple, matched with Cat Forest Machines provide high performance and reliability in logging applications.
- **Reinforced carbody design** stands up to the most demanding forest applications, assuring outstanding durability and service life.
- **Undercarriage** — Heavy-duty link assemblies provide toughness and durability, maximizing undercarriage life and minimizing operating costs. Long 10 roller track frames provide excellent machine stability and maneuverability on steep slopes.
- **Guarding** — Purpose designed guarding helps extend service life, reduces downtime and helps protect your forestry machine investment.
- **Operator station** — Spacious, quiet, automatically climate controlled cab has excellent sightlines to the work area. Cat offers a premium rear entry cab for those regions or operations that require this functionality.
- **Serviceability** — Simplified service and maintenance, and electronic diagnostics help save time, money and increase productivity.

<b>MODEL</b>	<b>320D Series 2 General Forestry</b>		<b>320D Series 2 Log Loader</b>		<b>320D Series 2 Feller Buncher</b>	
Gross Power	118 kW	<b>158 hp</b>	122 kW	<b>164 hp</b>	118 kW	<b>158 hp</b>
Operating Weight (with front linkage without bucket or grapple)	27 330 kg	<b>60,252 lb</b>	25 200 kg	<b>55,556 lb</b>	28 410 kg	<b>62,633 lb</b>
Swing Mechanism:						
Torque	73.2 kN-m	<b>54,000 lb-ft</b>	73.2 kN-m	<b>54,000 lb-ft</b>	73.2 kN-m	<b>54,000 lb-ft</b>
Speed		<b>11 RPM</b>		<b>11 RPM</b>		<b>11 RPM</b>
Engine Model	<b>C7.1 ACERT</b>		<b>C7.1 ACERT</b>		<b>C7.1 ACERT</b>	
Emission Standards	<b>Tier 3/Stage IIIA/ Japan 2006 (Tier 3) equivalent</b>		<b>Tier 3/Stage IIIA/ Japan 2006 (Tier 3) equivalent</b>		<b>Tier 3/Stage IIIA/ Japan 2006 (Tier 3) equivalent</b>	
No. of Cylinders	<b>6</b>		<b>6</b>		<b>6</b>	
Bore	105 mm	<b>4.1"</b>	105 mm	<b>4.1"</b>	105 mm	<b>4.1"</b>
Stroke	135 mm	<b>5.3"</b>	135 mm	<b>5.3"</b>	135 mm	<b>5.3"</b>
Displacement	7.01 L	<b>427.8 in<sup>3</sup></b>	7.01 L	<b>427.8 in<sup>3</sup></b>	7.01 L	<b>427.8 in<sup>3</sup></b>
Hydraulic System:						
Main Implement System — Maximum Flow (2x)	214 L/min	<b>56.5 gpm</b>	214 L/min	<b>56.5 gpm</b>	214 L/min	<b>56.5 gpm</b>
Relief Valve Settings:						
Implement Circuits	35 000 kPa	<b>5076 psi</b>	35 000 kPa	<b>5076 psi</b>	35 000 kPa	<b>5076 psi</b>
Travel Circuits	35 000 kPa	<b>5076 psi</b>	35 000 kPa	<b>5076 psi</b>	35 000 kPa	<b>5076 psi</b>
Swing Circuits	25 000 kPa	<b>3625 psi</b>	25 000 kPa	<b>3625 psi</b>	25 000 kPa	<b>3625 psi</b>
Pilot Circuits	3920 kPa	<b>569 psi</b>	3920 kPa	<b>569 psi</b>	3920 kPa	<b>569 psi</b>
Drive:						
Maximum Drawbar Pull — GF	248 kN	<b>55,700 lb</b>	—	—	272 kN	<b>61,193 lb</b>
Maximum Travel Speed — GF	4.3 km/h	<b>2.6 mph</b>	—	—	4.3 km/h	<b>2.7 mph</b>
Maximum Drawbar Pull — LL	—	—	188 kN	<b>42,264 lb</b>	—	—
Maximum Travel Speed — LL	—	—	5.6 km/h	<b>3.5 mph</b>	—	—
General Forestry Linkage:						
Bucket Cylinder — Bore	120 mm	<b>4.7"</b>	—	—	—	—
Bucket Cylinder — Stroke	1104 mm	<b>43.5"</b>	—	—	—	—
Feller Buncher Cylinder — Bore	135 mm	<b>5.3"</b>	—	—	—	—
Feller Buncher Cylinder — Stroke	1156 mm	<b>45.5"</b>	—	—	—	—
Log Loader Linkage:						
Boom Cylinder — Bore	—	—	120 mm	<b>4.7"</b>	—	—
Boom Cylinder — Stroke	—	—	1260 mm	<b>49.6"</b>	—	—
Stick Cylinder — Bore	—	—	140 mm	<b>5.5"</b>	—	—
Stick Cylinder — Stroke	—	—	1504 mm	<b>59.2"</b>	—	—
Track:						
Type of Track	<b>D5H</b>		<b>320 HEX</b>		<b>D5H</b>	
Pitch	191 mm	<b>7.5"</b>	191 mm	<b>7.5"</b>	191 mm	<b>7.5"</b>
Number of Rollers	<b>8</b>		<b>8</b>		<b>8</b>	
Overall Track Length	2790 mm	<b>109.8"</b>	2790 mm	<b>109.8"</b>	2790 mm	<b>109.8"</b>
Ground Clearance	659.5 mm	<b>26"</b>	659.5 mm	<b>26"</b>	659.5 mm	<b>26"</b>
Track Gauge	2790 mm	<b>109.8"</b>	2790 mm	<b>109.8"</b>	2790 mm	<b>109.8"</b>
Capacity:						
Fuel Tank (standard)	410 L	<b>108.3 U.S. gal</b>	410 L	<b>108.3 U.S. gal</b>	410 L	<b>108.3 U.S. gal</b>
Fuel Tank (optional auxiliary right front)	410 L	<b>108.3 U.S. gal</b>	410 L	<b>108.3 U.S. gal</b>	410 L	<b>108.3 U.S. gal</b>
Cooling System	25 L	<b>6.6 U.S. gal</b>	25 L	<b>6.6 U.S. gal</b>	25 L	<b>6.6 U.S. gal</b>
Engine Oil	30 L	<b>7.9 U.S. gal</b>	30 L	<b>7.9 U.S. gal</b>	30 L	<b>7.9 U.S. gal</b>
Swing Drive	8 L	<b>2.1 U.S. gal</b>	8 L	<b>2.1 U.S. gal</b>	8 L	<b>2.1 U.S. gal</b>
Hydraulic System — Total	260 L	<b>68.7 U.S. gal</b>	260 L	<b>68.7 U.S. gal</b>	260 L	<b>68.7 U.S. gal</b>
Hydraulic System — Tank	138 L	<b>36.5 U.S. gal</b>	138 L	<b>36.5 U.S. gal</b>	138 L	<b>36.5 U.S. gal</b>
Final Drive (General Forestry)	13 L	<b>3.4 U.S. gal</b>	—	—	13 L	<b>3.4 U.S. gal</b>
Final Drive (Log Loader)	—	—	10 L	<b>2.6 U.S. gal</b>	—	—

MODEL	538		538 LL Under/Under		538 with trial Over/Under	
Gross Power	122 kW	<b>164 hp</b>	122 kW	<b>164 hp</b>	122 kW	<b>164 hp</b>
Operating Weight (with front linkage, without bucket or grapple)	30 227 kg	<b>66,640 lb</b>	31 558 kg	<b>69,574 lb</b>	31 480 kg	<b>69,401 lb</b>
Swing Mechanism:						
Torque	80 kN·m	<b>59,300 lb-ft</b>	80 kN·m	<b>59,300 lb-ft</b>	80 kN·m	<b>59,300 lb-ft</b>
Speed	<b>11 RPM</b>		<b>11 RPM</b>		<b>11 RPM</b>	
Engine Model	<b>C7.1 ACERT</b>		<b>C7.1 ACERT</b>		<b>C7.1 ACERT</b>	
Emission Standards	<b>Tier 4 Final/Stage IV/ Japan 2014 (Tier 4 Final)</b>		<b>Tier 4 Final/Stage IV/ Japan 2014 (Tier 4 Final)</b>		<b>Tier 4 Final/Stage IV/ Japan 2014 (Tier 4 Final)</b>	
No. of Cylinders	<b>6</b>		<b>6</b>		<b>6</b>	
Bore	105 mm	<b>4.1"</b>	105 mm	<b>4.1"</b>	105 mm	<b>4.1"</b>
Stroke	135 mm	<b>5.3"</b>	135 mm	<b>5.3"</b>	135 mm	<b>5.3"</b>
Displacement	7.01 L	<b>427.8 in<sup>3</sup></b>	7.01 L	<b>427.8 in<sup>3</sup></b>	7.01 L	<b>427.8 in<sup>3</sup></b>
Hydraulic System:						
Main Implement System — Maximum Flow (2x)	212 L/min	<b>56 gpm</b>	212 L/min	<b>56 gpm</b>	212 L/min	<b>56 gpm</b>
Relief Valve Settings:						
Implement Circuits	35 000 kPa	<b>5076 psi</b>	35 000 kPa	<b>5076 psi</b>	35 000 kPa	<b>5076 psi</b>
Travel Circuits	35 000 kPa	<b>5076 psi</b>	35 000 kPa	<b>5076 psi</b>	35 000 kPa	<b>5076 psi</b>
Swing Circuits	31 000 kPa	<b>4496 psi</b>	31 000 kPa	<b>4496 psi</b>	31 000 kPa	<b>4496 psi</b>
Drive:						
Maximum Drawbar Pull	272 kN	<b>61,193 lb</b>	272 kN	<b>61,193 lb</b>	272 kN	<b>61,193 lb</b>
Maximum Travel Speed (Rabbit)	4.3 km/h	<b>2.7 mph</b>	4.3 km/h	<b>2.7 mph</b>	4.3 km/h	<b>2.7 mph</b>
Maximum Travel Speed (Turtle)	2.6 km/h	<b>1.6 mph</b>	2.6 km/h	<b>1.6 mph</b>	2.6 km/h	<b>1.6 mph</b>
General Forestry Linkage:						
Boom Cylinder — Bore	120 mm	<b>4.7"</b>	—	—	—	—
Boom Cylinder — Stroke	1260 mm	<b>49.6"</b>	—	—	—	—
Stick Cylinder — Bore	140 mm	<b>5.5"</b>	—	—	—	—
Stick Cylinder — Stroke	1504 mm	<b>59.2"</b>	—	—	—	—
Bucket Cylinder — Bore	120 mm	<b>4.7"</b>	—	—	—	—
Bucket Cylinder — Stroke	1104 mm	<b>43.5"</b>	—	—	—	—
Log Loader Linkage:						
Boom Cylinder — Bore	—	—	140 mm	<b>5.5"</b>	140 mm	<b>5.5"</b>
Boom Cylinder — Stroke	—	—	1160 mm	<b>45.7"</b>	1160 mm	<b>45.7"</b>
Stick Cylinder — Bore	—	—	150 mm	<b>5.9"</b>	150 mm	<b>5.9"</b>
Stick Cylinder — Stroke	—	—	1470 mm	<b>57.9"</b>	1470 mm	<b>57.9"</b>
Heel Cylinder — Bore	—	—	130 mm	<b>5.1"</b>	130 mm	<b>5.1"</b>
Heel Cylinder — Stroke	—	—	1156 mm	<b>45.5"</b>	1156 mm	<b>45.5"</b>
Track:						
Type of Track	<b>329E HEX</b>		<b>329E HEX</b>		<b>329E HEX</b>	
Pitch	202.8 mm	<b>8"</b>	202.8 mm	<b>8"</b>	202.8 mm	<b>8"</b>
Number of Rollers	<b>8</b>		<b>8</b>		<b>8</b>	
Overall Track Length	2790 mm	<b>109.8"</b>	2790 mm	<b>109.8"</b>	2790 mm	<b>109.8"</b>
Ground Clearance	659.5 mm	<b>26"</b>	659.5 mm	<b>26"</b>	659.5 mm	<b>26"</b>
Track Gauge	2790 mm	<b>109.8"</b>	2790 mm	<b>109.8"</b>	2790 mm	<b>109.8"</b>
Capacity:						
Fuel Tank (standard)	410 L	<b>108.3 U.S. gal</b>	410 L	<b>108.3 U.S. gal</b>	410 L	<b>108.3 U.S. gal</b>
Cooling System	29.8 L	<b>7.9 U.S. gal</b>	29.8 L	<b>7.9 U.S. gal</b>	29.8 L	<b>7.9 U.S. gal</b>
Engine Oil	25 L	<b>6.6 U.S. gal</b>	25 L	<b>6.6 U.S. gal</b>	25 L	<b>6.6 U.S. gal</b>
Swing Drive	8 L	<b>2.1 U.S. gal</b>	8 L	<b>2.1 U.S. gal</b>	8 L	<b>2.1 U.S. gal</b>
Hydraulic System — Total	159.0 L	<b>42.0 U.S. gal</b>	159.0 L	<b>42.0 U.S. gal</b>	159.0 L	<b>42.0 U.S. gal</b>
Hydraulic System — Tank	143.0 L	<b>37.8 U.S. gal</b>	143.0 L	<b>37.8 U.S. gal</b>	143.0 L	<b>37.8 U.S. gal</b>
Final Drive (each)	8.0 L	<b>2.1 U.S. gal</b>	8.0 L	<b>2.1 U.S. gal</b>	8.0 L	<b>2.1 U.S. gal</b>

<b>MODEL</b>	<b>324D FM General Forestry (HW)</b>		<b>324D FM Log Loader (U/U)</b>		<b>324D FM Log Loader (O/U)</b>	
Net Flywheel Power (SAE J1349)	140 kW	<b>188 hp</b>	140 kW	<b>188 hp</b>	140 kW	<b>188 hp</b>
Operating Weight (with front linkage, without bucket or grapple)	32 105 kg	<b>70,631 lb</b>	34 975 kg	<b>76,945 lb</b>	35 115 kg	<b>77,253 lb</b>
Swing Mechanism:						
Torque	84.5 kN·m	<b>62,300 lb-ft</b>	84.5 kN·m	<b>62,300 lb-ft</b>	84.5 kN·m	<b>62,300 lb-ft</b>
Speed	<b>10 RPM</b>		<b>10 RPM</b>		<b>10 RPM</b>	
Engine Model	<b>C7 ACERT</b>		<b>C7 ACERT</b>		<b>C7 ACERT</b>	
Emission Standards	<b>Tier 3/Stage IIIA/ Japan 2006 (Tier 3) equivalent</b>		<b>Tier 3/Stage IIIA/ Japan 2006 (Tier 3) equivalent</b>		<b>Tier 3/Stage IIIA/ Japan 2006 (Tier 3) equivalent</b>	
No. of Cylinders	<b>6</b>		<b>6</b>		<b>6</b>	
Bore	110 mm	<b>4.3"</b>	110 mm	<b>4.3"</b>	110 mm	<b>4.3"</b>
Stroke	127 mm	<b>5"</b>	127 mm	<b>5"</b>	127 mm	<b>5"</b>
Displacement	7.2 L	<b>440 in<sup>3</sup></b>	7.2 L	<b>440 in<sup>3</sup></b>	7.2 L	<b>440 in<sup>3</sup></b>
Hydraulic System:						
Main Implement System — Maximum Flow (2x)	220 L/min	<b>58.1 gpm</b>	220 L/min	<b>58.1 gpm</b>	220 L/min	<b>58.1 gpm</b>
Relief Valve Settings:						
Implement Circuits	35 000 kPa	<b>5075 psi</b>	35 000 kPa	<b>5075 psi</b>	35 000 kPa	<b>5075 psi</b>
Travel Circuits	35 000 kPa	<b>5075 psi</b>	35 000 kPa	<b>5075 psi</b>	35 000 kPa	<b>5075 psi</b>
Swing Circuits	24 500 kPa	<b>3553 psi</b>	24 500 kPa	<b>3553 psi</b>	24 500 kPa	<b>3553 psi</b>
Pilot Circuits	3920 kPa	<b>568 psi</b>	3920 kPa	<b>568 psi</b>	3920 kPa	<b>568 psi</b>
Drive:						
Maximum Drawbar Pull	259 kN	<b>58,226 lb</b>	259 kN	<b>58,226 lb</b>	259 kN	<b>58,226 lb</b>
Maximum Travel Speed	5.7 km/h	<b>3.5 mph</b>	5.7 km/h	<b>3.5 mph</b>	5.7 km/h	<b>3.5 mph</b>
Log Loader Linkage:						
Boom Cylinder — Bore	140 mm	<b>5.5"</b>	140 mm	<b>5.5"</b>	140 mm	<b>5.5"</b>
Boom Cylinder — Stroke	1185 mm	<b>46.7"</b>	1185 mm	<b>46.7"</b>	1185 mm	<b>46.7"</b>
Stick Cylinder — Bore	170 mm	<b>6.7"</b>	170 mm	<b>6.7"</b>	170 mm	<b>6.7"</b>
Stick Cylinder — Stroke	1680 mm	<b>66.1"</b>	1680 mm	<b>66.1"</b>	1680 mm	<b>66.1"</b>
Under/Under Heel Cylinder — Bore	—		130 mm	<b>5.1"</b>	—	
Under/Under Heel Cylinder — Stroke	—		1156 mm	<b>45.5"</b>	—	
Over/Under Heel Cylinder — Bore	—		—		150 mm	<b>5.9"</b>
Over/Under Heel Cylinder — Stroke	—		—		1470 mm	<b>57.9"</b>
Track:						
Standard (HD double grouser)	700 mm	<b>28"</b>	700 mm	<b>28"</b>	700 mm	<b>28"</b>
Optional (double grouser)	600 mm	<b>24"</b>	600 mm	<b>24"</b>	600 mm	<b>24"</b>
Optional (HD triple grouser)	850 mm	<b>34"</b>	850 mm	<b>34"</b>	850 mm	<b>34"</b>
Overall Track Length	4967 mm	<b>16'4"</b>	4967 mm	<b>16'4"</b>	4967 mm	<b>16'4"</b>
Ground Clearance	743 mm	<b>2'5"</b>	743 mm	<b>2'5"</b>	743 mm	<b>2'5"</b>
Track Gauge	2920 mm	<b>9'7"</b>	2920 mm	<b>9'7"</b>	2920 mm	<b>9'7"</b>
Capacity:						
Fuel Tank (standard)	520 L	<b>137.4 U.S. gal</b>	520 L	<b>137.4 U.S. gal</b>	520 L	<b>137.4 U.S. gal</b>
Fuel Tank (optional auxiliary right front)	410 L	<b>108.3 U.S. gal</b>	410 L	<b>108.3 U.S. gal</b>	410 L	<b>108.3 U.S. gal</b>
Cooling System	30 L	<b>7.9 U.S. gal</b>	30 L	<b>7.9 U.S. gal</b>	30 L	<b>7.9 U.S. gal</b>
Engine Oil	34 L	<b>9.0 U.S. gal</b>	34 L	<b>9.0 U.S. gal</b>	34 L	<b>9.0 U.S. gal</b>
Swing Drive	8 L	<b>2.1 U.S. gal</b>	8 L	<b>2.1 U.S. gal</b>	8 L	<b>2.1 U.S. gal</b>
Hydraulic System — Total	245 L	<b>64.7 U.S. gal</b>	245 L	<b>64.7 U.S. gal</b>	245 L	<b>64.7 U.S. gal</b>
Hydraulic System — Tank	145 L	<b>38.3 U.S. gal</b>	145 L	<b>38.3 U.S. gal</b>	145 L	<b>38.3 U.S. gal</b>
Final Drive (each)	8 L	<b>2.1 U.S. gal</b>	8 L	<b>2.1 U.S. gal</b>	8 L	<b>2.1 U.S. gal</b>

MODEL	325D FM General Forestry (HW)		325D FM Log Loader (U/U)		325D FM Log Loader (O/U)	
	152 kW	204 hp	152 kW	204 hp	152 kW	204 hp
Net Flywheel Power (SAE J1349)	152 kW	204 hp	152 kW	204 hp	152 kW	204 hp
Operating Weight (with front linkage, without bucket or grapple)	36 951 kg	81,466 lb	41 430 kg	91,338 lb	41 834 kg	92,229 lb
Swing Mechanism:						
Torque	99.3 kN·m	73,213 lb-ft	99.3 kN·m	73,213 lb-ft	99.3 kN·m	73,213 lb-ft
Speed	10 RPM		10 RPM		10 RPM	
Engine Model	C7 ACERT		C7 ACERT		C7 ACERT	
Emission Standards	Tier 3/Stage IIIA/ Japan 2006 (Tier 3) equivalent		Tier 3/Stage IIIA/ Japan 2006 (Tier 3) equivalent		Tier 3/Stage IIIA/ Japan 2006 (Tier 3) equivalent	
No. of Cylinders	6		6		6	
Bore	110 mm	4.3"	110 mm	4.3"	110 mm	4.3"
Stroke	127 mm	5"	127 mm	5"	127 mm	5"
Displacement	7.2 L	440 in <sup>3</sup>	7.2 L	440 in <sup>3</sup>	7.2 L	440 in <sup>3</sup>
Hydraulic System:						
Main Implement System — Maximum Flow (2x)	235 L/min	62.1 gpm	235 L/min	62.1 gpm	235 L/min	62.1 gpm
Relief Valve Settings:						
Implement Circuits	35 000 kPa	5075 psi	35 000 kPa	5075 psi	35 000 kPa	5075 psi
Travel Circuits	35 000 kPa	5075 psi	35 000 kPa	5075 psi	35 000 kPa	5075 psi
Swing Circuits	27 500 kPa	3988 psi	27 500 kPa	3988 psi	27 500 kPa	3988 psi
Pilot Circuits	4120 kPa	597 psi	4120 kPa	597 psi	4120 kPa	597 psi
Drive:						
Maximum Drawbar Pull	317 kN	71,264 lb	317 kN	71,264 lb	317 kN	71,264 lb
Maximum Travel Speed	4.8 km/h	3 mph	4.8 km/h	3 mph	4.8 km/h	3 mph
Log Loader Linkage:						
Boom Cylinder — Bore	150 mm	5.9"	150 mm	5.9"	150 mm	5.9"
Boom Cylinder — Stroke	1400 mm	55.1"	1400 mm	55.1"	1400 mm	55.1"
Stick Cylinder — Bore	180 mm	7.1"	180 mm	7.1"	180 mm	7.1"
Stick Cylinder — Stroke	1650 mm	65"	1650 mm	65"	1650 mm	65"
Under/Under Heel Cylinder — Bore	—		150 mm	5.9"	—	
Under/Under Heel Cylinder — Stroke	—		1155 mm	45.5"	—	
Over/Under Heel Cylinder — Bore	—		—		160 mm	6.3"
Over/Under Heel Cylinder — Stroke	—		—		1465 mm	57.7"
Track:						
Standard (HD double grouser)	700 mm	28"	700 mm	28"	700 mm	28"
Optional (HD triple grouser)	850 mm	34"	850 mm	34"	850 mm	34"
Overall Track Length	5060 mm	16'7"	5060 mm	16'7"	5060 mm	16'7"
Ground Clearance	760 mm	2'6"	760 mm	2'6"	760 mm	2'6"
Track Gauge	2920 mm	9'7"	2920 mm	9'7"	2920 mm	9'7"
Capacity:						
Fuel Tank (standard)	520 L	137.4 U.S. gal	520 L	137.4 U.S. gal	520 L	137.4 U.S. gal
Fuel Tank — Optional Auxiliary Right Front	410 L	108.3 U.S. gal	410 L	108.3 U.S. gal	410 L	108.3 U.S. gal
Cooling System	30 L	7.9 U.S. gal	30 L	7.9 U.S. gal	30 L	7.9 U.S. gal
Engine Oil	34 L	9.0 U.S. gal	34 L	9.0 U.S. gal	34 L	9.0 U.S. gal
Swing Drive	10 L	2.6 U.S. gal	10 L	2.6 U.S. gal	10 L	2.6 U.S. gal
Hydraulic System — Total	260 L	68.7 U.S. gal	260 L	68.7 U.S. gal	260 L	68.7 U.S. gal
Hydraulic System — Tank	145 L	38.3 U.S. gal	145 L	38.3 U.S. gal	145 L	38.3 U.S. gal
Final Drive (each)	8 L	2.1 U.S. gal	8 L	2.1 U.S. gal	8 L	2.1 U.S. gal

<b>MODEL</b>	<b>558 LL Under/Under</b>		<b>558 LL Over/Under</b>	
Gross Power	178 kW	<b>239 hp</b>	178 kW	<b>239 hp</b>
Operating Weight (with front linkage, without bucket or grapple)	42 264 kg	<b>93,176 lb</b>	42 186 kg	<b>93,004 lb</b>
Swing Mechanism:				
Torque	117 kN·m	<b>86,000 lb-ft</b>	117 kN·m	<b>86,000 lb-ft</b>
Speed	<b>7.5 RPM</b>		<b>7.5 RPM</b>	
Engine Model	<b>C7.1 ACERT</b>		<b>C7.1 ACERT</b>	
Emission Standards	<b>Tier 4 Final/Stage IV/ Japan 2014 (Tier 4 Final)</b>		<b>Tier 4 Final/Stage IV/ Japan 2014 (Tier 4 Final)</b>	
No. of Cylinders	<b>6</b>		<b>—</b>	
Bore	105 mm	<b>4.1"</b>	105 mm	<b>4.1"</b>
Stroke	135 mm	<b>5.3"</b>	135 mm	<b>5.3"</b>
Displacement	7.01 L	<b>427.8 in<sup>3</sup></b>	7.01 L	<b>427.8 in<sup>3</sup></b>
Hydraulic System:				
Main Implement System — Maximum Flow (2x)	240 L/min	<b>63 gpm</b>	240 L/min	<b>63 gpm</b>
Relief Valve Settings:				
Implement Circuits	35 000 kPa	<b>5076 psi</b>	35 000 kPa	<b>5076 psi</b>
Travel Circuits	35 000 kPa	<b>5076 psi</b>	35 000 kPa	<b>5076 psi</b>
Swing Circuits	32 000 kPa	<b>4641 psi</b>	32 000 kPa	<b>4641 psi</b>
Drive:				
Maximum Drawbar Pull	321 kN	<b>72,230 lb</b>	321 kN	<b>72,230 lb</b>
Maximum Travel Speed (Rabbit)	3.7 km/h	<b>2.3 mph</b>	3.7 km/h	<b>2.3 mph</b>
Maximum Travel Speed (Turtle)	2.4 km/h	<b>1.5 mph</b>	2.4 km/h	<b>1.5 mph</b>
Log Loader Linkage:				
Boom Cylinder — Bore	150 mm	<b>5.9"</b>	150 mm	<b>5.9"</b>
Boom Cylinder — Stroke	1400 mm	<b>4.1"</b>	1400 mm	<b>4.1"</b>
Stick Cylinder — Bore	180 mm	<b>7.1"</b>	180 mm	<b>7.1"</b>
Stick Cylinder — Stroke	1651 mm	<b>65.0"</b>	1651 mm	<b>65.0"</b>
Heel Cylinder — Bore	150 mm	<b>5.9"</b>	150 mm	<b>5.9"</b>
Heel Cylinder — Stroke	1156 mm	<b>45.5"</b>	1156 mm	<b>45.5"</b>
Track:				
Type of Track	<b>349 HEX</b>		<b>349 HEX</b>	
Pitch	215.9 mm	<b>8.5"</b>	215.9 mm	<b>8.5"</b>
Number of Rollers	<b>8</b>		<b>8</b>	
Overall Track Length	5072 mm	<b>199.7"</b>	5072 mm	<b>199.7"</b>
Ground Clearance	749 mm	<b>29.5"</b>	749 mm	<b>29.5"</b>
Track Gauge	2921 mm	<b>115"</b>	2921 mm	<b>115"</b>
Capacity:				
Fuel Tank (standard — counterweight)	998.6 L	<b>263.8 U.S. gal</b>	998.6 L	<b>263.8 U.S. gal</b>
Cooling System	30 L	<b>7.9 U.S. gal</b>	30 L	<b>7.9 U.S. gal</b>
Engine Oil	24 L	<b>6.3 U.S. gal</b>	24 L	<b>6.3 U.S. gal</b>
Swing Drive	11 L	<b>2.9 U.S. gal</b>	11 L	<b>2.9 U.S. gal</b>
Hydraulic System — Total	310 L	<b>81.9 U.S. gal</b>	310 L	<b>81.9 U.S. gal</b>
Hydraulic System — Tank	175 L	<b>46.2 U.S. gal</b>	175 L	<b>46.2 U.S. gal</b>
Final Drive (each)	11 L	<b>2.9 U.S. gal</b>	11 L	<b>2.9 U.S. gal</b>

MODEL	568 FM General Forestry (HW)		568 FM Log Loader (U/U)		568 FM Log Loader (O/U)	
	221 kW	296 hp	221 kW	296 hp	221 kW	296 hp
Net Flywheel Power (SAE J1349)	221 kW	296 hp	221 kW	296 hp	221 kW	296 hp
Operating Weight (with front linkage, without bucket or grapple)	43 462 kg	95,616 lb	48 694 kg	107,128 lb	48 853 kg	107,478 lb
Swing Mechanism:						
Torque	113.9 kN·m	84,024 lb-ft	148.5 kN·m	109,560 lb-ft	148.5 kN·m	109,560 lb-ft
Speed	10 RPM		6.3 RPM		6.3 RPM	
Engine Model	C9.3 ACERT		C9.3 ACERT		C9.3 ACERT	
Emission Standards	Tier 4 Interim/Stage IIIB/ Japan 2011 (Tier 4 Interim) equivalent		Tier 4 Interim/Stage IIIB/ Japan 2011 (Tier 4 Interim) equivalent		Tier 4 Interim/Stage IIIB/ Japan 2011 (Tier 4 Interim) equivalent	
No. of Cylinders	6		6		6	
Bore	115 mm	4.53"	115 mm	4.53"	115 mm	4.53"
Stroke	149 mm	5.87"	149 mm	5.87"	149 mm	5.87"
Displacement	9.3 L	567.5 in <sup>3</sup>	9.3 L	567.5 in <sup>3</sup>	9.3 L	567.5 in <sup>3</sup>
Hydraulic System:						
Main Implement System — Maximum Flow (2x)	26 L/min	6.87 gpm	26 L/min	6.87 gpm	26 L/min	6.87 gpm
Relief Valve Settings:						
Implement Circuits	35 000 kPa	5076 psi	35 000 kPa	5076 psi	35 000 kPa	5076 psi
Maximum Pressure — Swing (single)	28 000 kPa	4061 psi	28 000 kPa	4061 psi	28 000 kPa	4061 psi
Maximum Pressure — Swing (dual)	31 400 kPa	4550 psi	31 400 kPa	4550 psi	31 400 kPa	4550 psi
Drive:						
Maximum Drawbar Pull	317 kN	71,264 lb-ft	317 kN	71,264 lb-ft	317 kN	71,264 lb-ft
Maximum Travel Speed	4.8 km/h	3 mph	4.8 km/h	3 mph	4.8 km/h	3 mph
Log Loader Linkage:						
Boom Cylinder — Bore	170 mm	6.7"	170 mm	6.7"	170 mm	6.7"
Boom Cylinder — Stroke	1340 mm	52.8"	1340 mm	52.8"	1340 mm	52.8"
Stick Cylinder — Bore	180 mm	7.1"	180 mm	7.1"	180 mm	7.1"
Stick Cylinder — Stroke	1661 mm	65.4"	1661 mm	65.4"	1661 mm	65.4"
Under/Under Heel Cylinder — Bore	150 mm	5.9"	150 mm	5.9"	150 mm	5.9"
Under/Under Heel Cylinder — Stroke	1155 mm	45.5"	1155 mm	45.5"	1155 mm	45.5"
Over/Under Heel Cylinder — Bore	160 mm	6.3"	160 mm	6.3"	160 mm	6.3"
Over/Under Heel Cylinder — Stroke	1465 mm	57.7"	1465 mm	57.7"	1465 mm	57.7"
Track:						
Standard (HD double grouser)	700 mm	28"	700 mm	28"	700 mm	28"
Optional (HD triple grouser)	850 mm	34"	850 mm	34"	850 mm	34"
Overall Track Length	5390 mm	212"	5390 mm	212"	5390 mm	212"
Ground Clearance	760 mm	30"	760 mm	30"	760 mm	30"
Track Gauge	2920 mm	115"	2920 mm	115"	2920 mm	115"
Capacity:						
Fuel Tank (standard)	1200 L	317 U.S. gal	1200 L	317 U.S. gal	1200 L	317 U.S. gal
Cooling System	56 L	14.8 U.S. gal	56 L	14.8 U.S. gal	56 L	14.8 U.S. gal
Engine Oil	30.5 L	8.1 U.S. gal	30.5 L	8.1 U.S. gal	30.5 L	8.1 U.S. gal
Swing Drive (each)	19 L	5 U.S. gal	20 L	5.3 U.S. gal	20 L	5.3 U.S. gal
Hydraulic System — Total	380 L	100.4 U.S. gal	380 L	100.4 U.S. gal	380 L	100.4 U.S. gal
Hydraulic System — Tank	175 L	46.2 U.S. gal	175 L	46.2 U.S. gal	175 L	46.2 U.S. gal
Final Drive (each)	8 L	2.1 U.S. gal	8 L	2.1 U.S. gal	8 L	2.1 U.S. gal



**General Forestry  
Harvester**

**5.7 m (18'8") Straight Boom with Processor  
2.9 m (9'6") Stick**

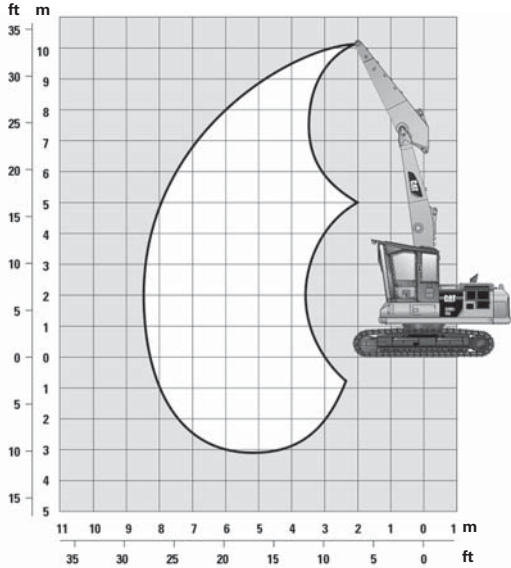

**General Forestry  
Harvester**

**5.7 m (18'8") Curved Boom with Processor  
2.9 m (9'6") Stick**

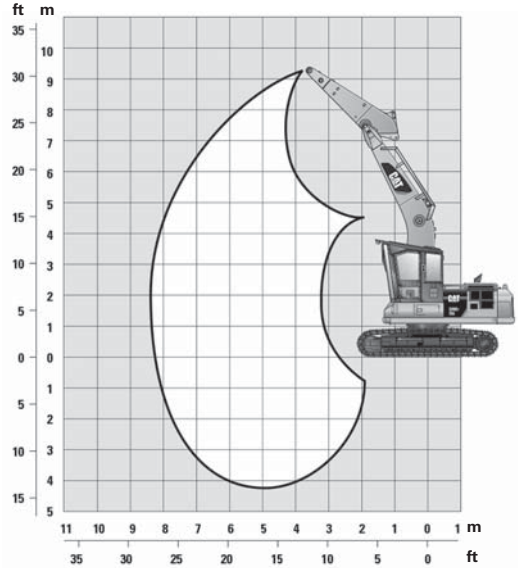

**General Forestry  
Feller Buncher**

**5.2 m (17'1") Boom with 2.4 m (7'10") Stick**

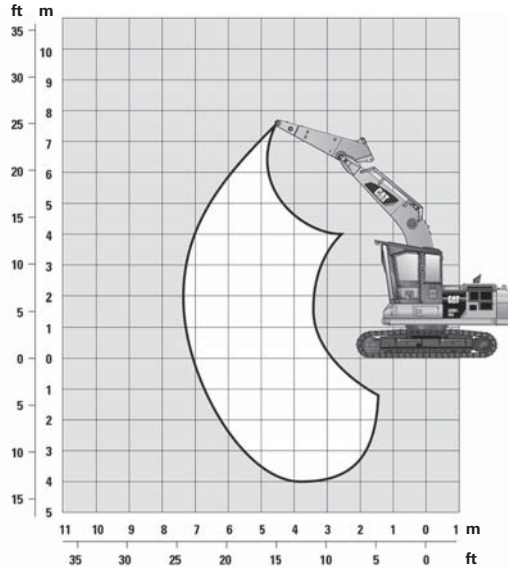

**Log Loader  
 HD/LC  
 5.7 m (18'8") HD R Curved Boom  
 with R2.9B1 (9'6") Stick**

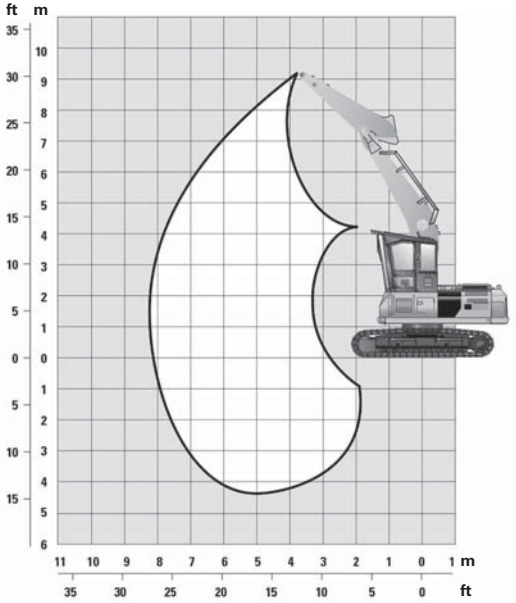

**Log Loader  
 HD/LC  
 5.7 m (18'8") Straight Boom  
 with R2.9B1 (9'6") Stick**

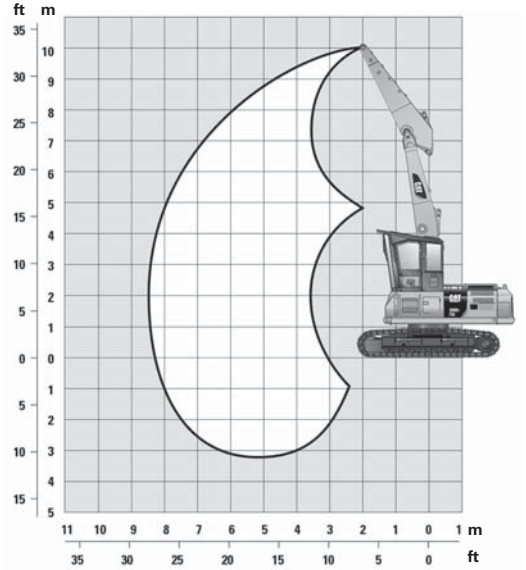

General Forestry  
Harvester Stick

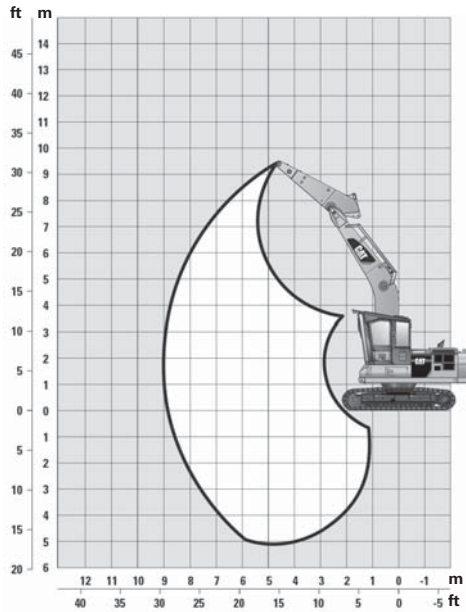

General Forestry  
2.9 m (9'6") Stick

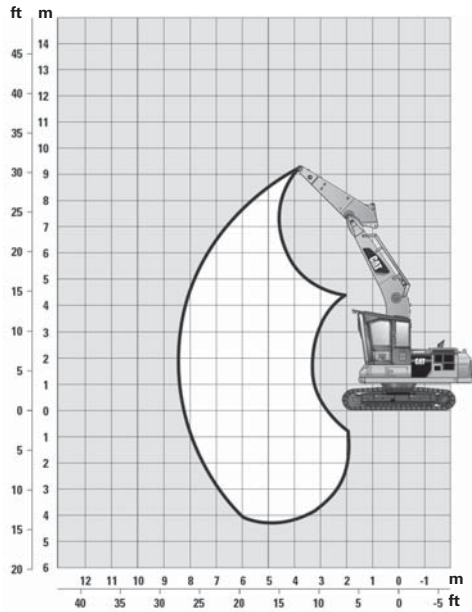

Under/Under

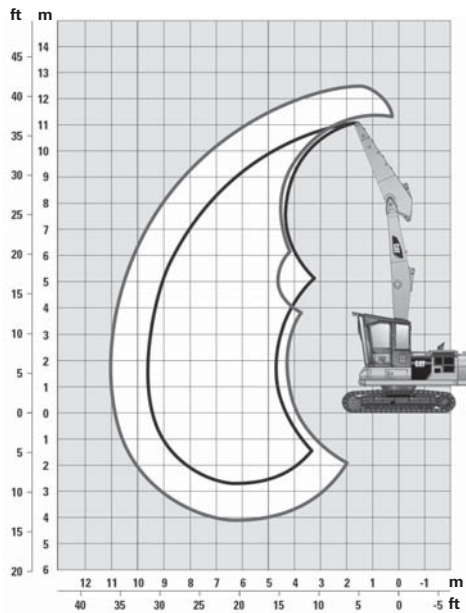

### Over/Under

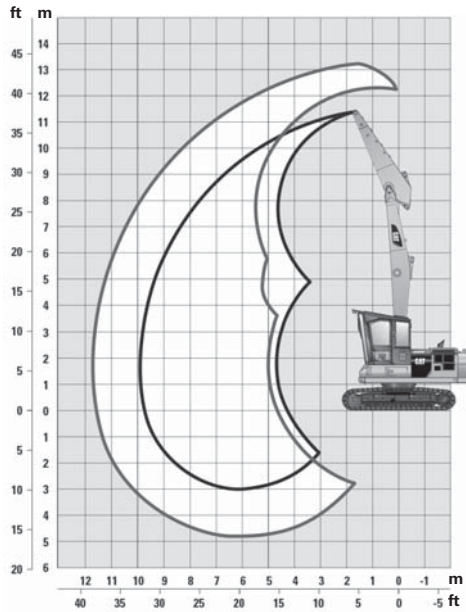

### Powerclam

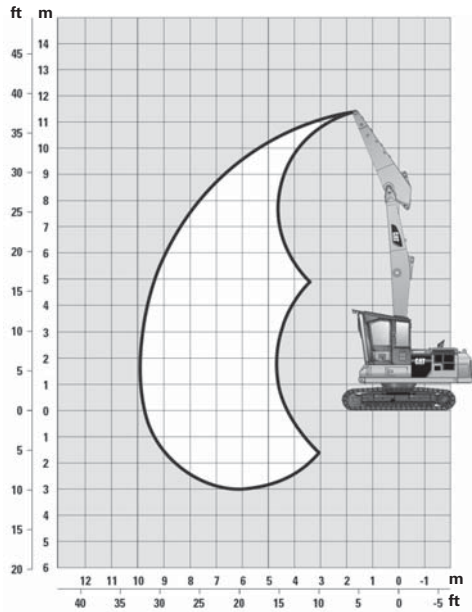

5

### Material Handler

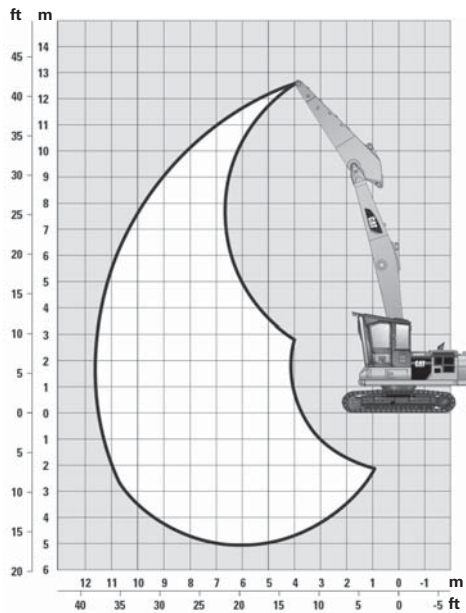

**Heel Boom  
Under/Under**

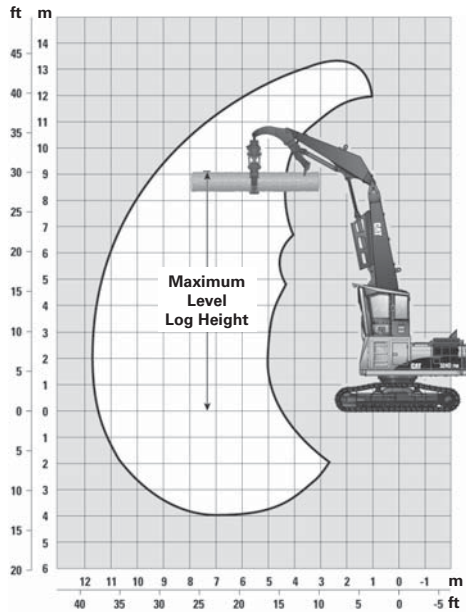

**Heel Boom  
Over/Under**

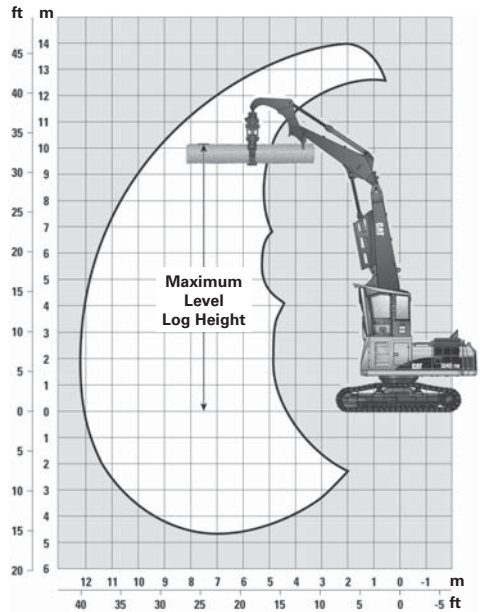

**General Forestry  
HW U/C, 5.9 m (19'4") Boom  
with 2.95S Stick**

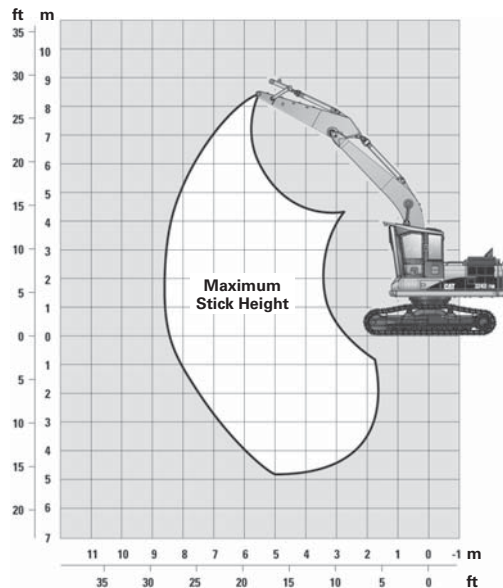

**Heel Boom  
Under/Under**

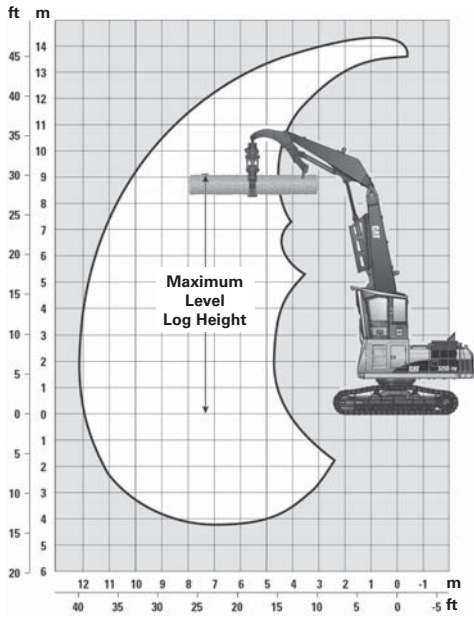

**Heel Boom  
Over/Under**

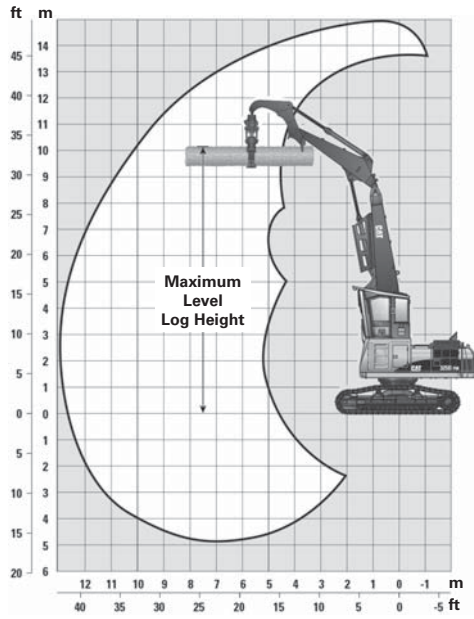

5

**Log Loader  
(Butt-n-Top)**

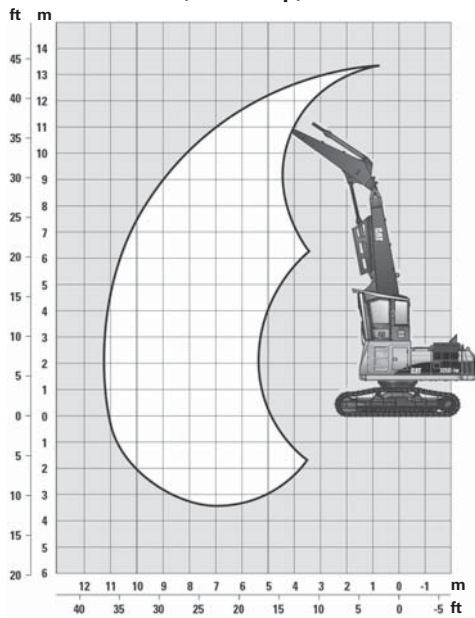

**General Forestry**  
Mass Boom 5.5 m (18'2")  
Stick 3.2 m (10'2")

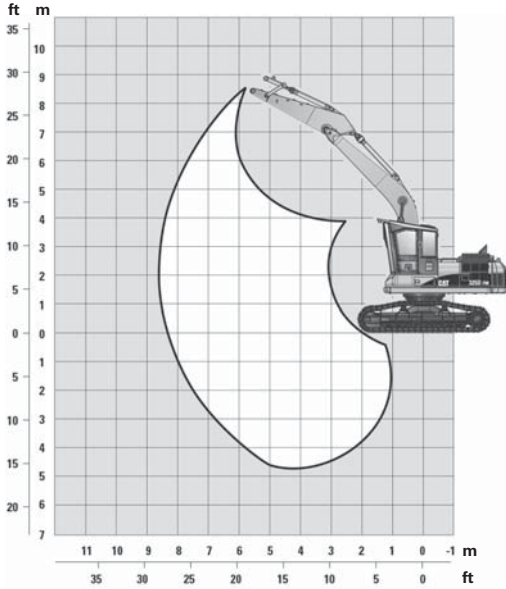

**General Forestry**  
Reach Boom 6.2 m (20'2")  
Stick 3.2 m (10'2")

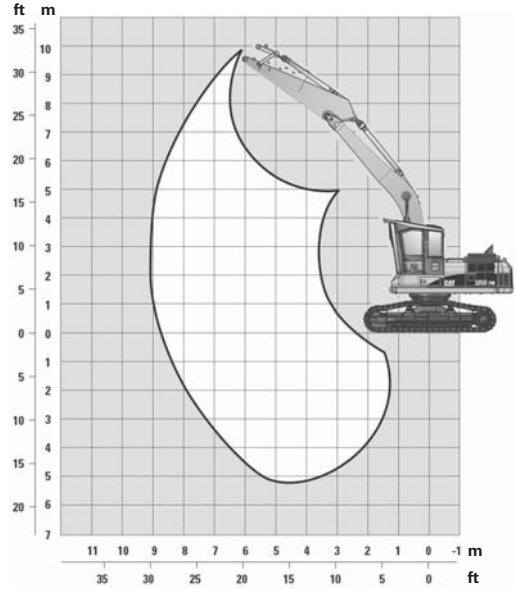

**Heel Boom  
Under/Under**

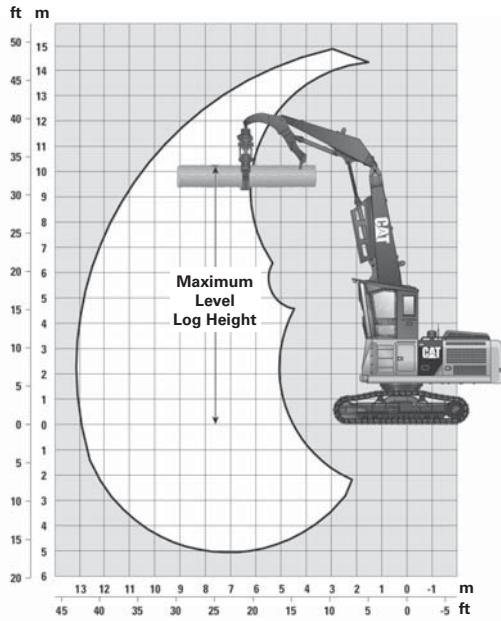

**Heel Boom  
Over/Under**

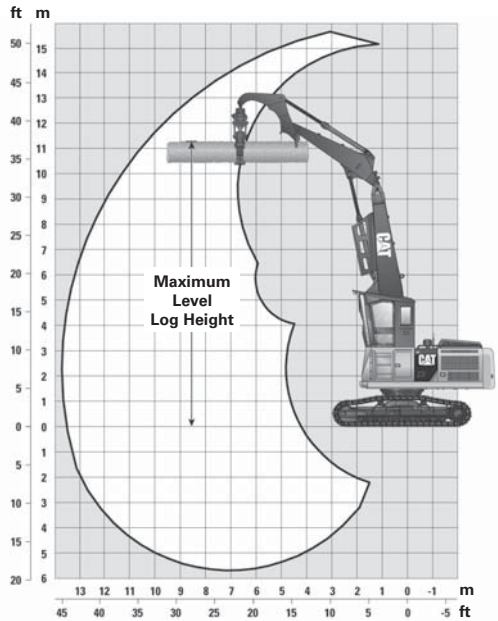

5

**General Forestry  
3.9 m (12'10") Reach Boom**

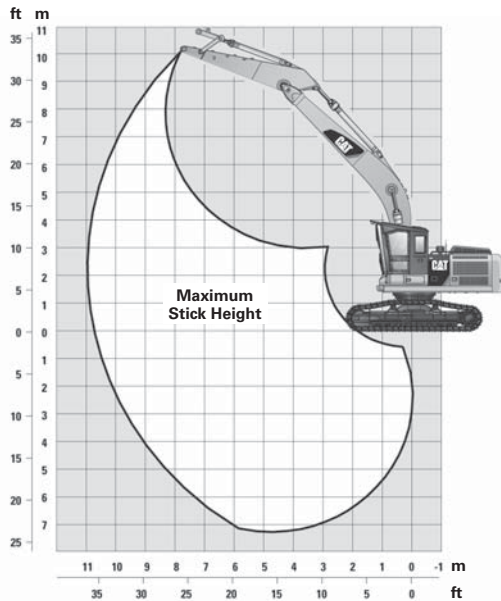

**General Forestry  
3.5 m (11'6") Reach Boom**

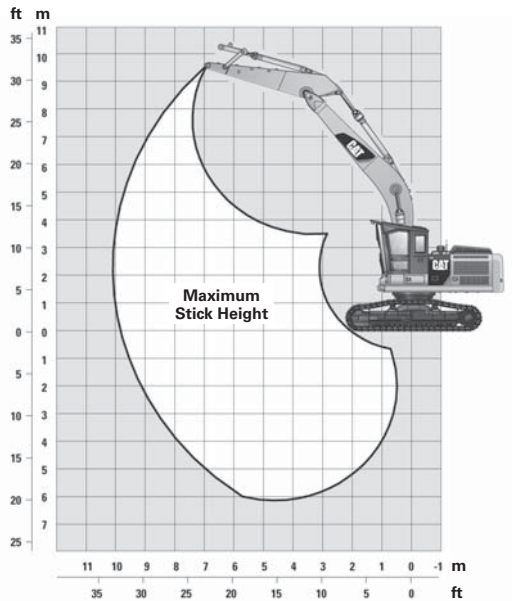



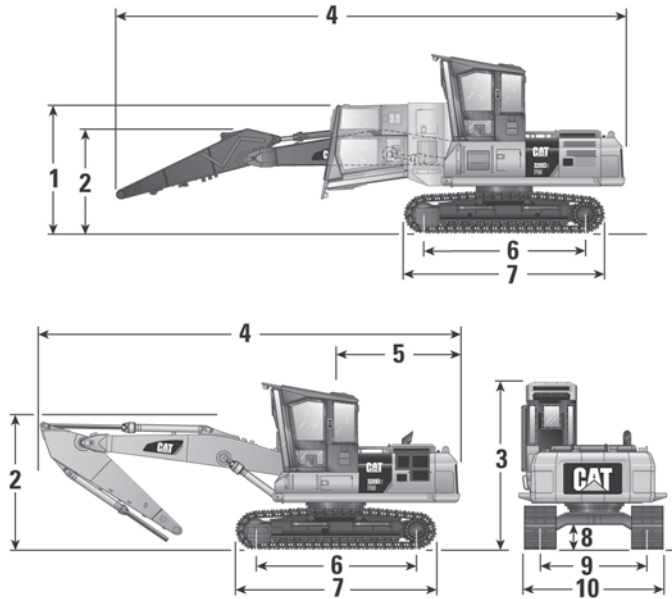

**320D2 FM**

	Log Loader*		General Forestry**	
<b>1</b> Shipping height (All risers with cab tilted)	3203 mm	<b>10'6"</b>	3226 mm	<b>10'7"</b>
<b>2</b> Boom height	3040 mm	<b>10'0"</b>	3060 mm	<b>10'0"</b>
<b>3</b> Overall height	4093 mm	<b>13'5"</b>	3842 mm	<b>12'7"</b>
<b>4</b> Shipping length	9460 mm	<b>31'0"</b>	9460 mm	<b>31'0"</b>
<b>5</b> Tail swing radius	2721 mm	<b>8'11"</b>	2721 mm	<b>8'11"</b>
<b>6</b> Length to centers of rollers	3650 mm	<b>12'0"</b>	3715 mm	<b>12'2"</b>
<b>7</b> Track length	4475 mm	<b>14'8"</b>	4555 mm	<b>14'11"</b>
<b>8</b> Ground clearance	479 mm	<b>1'7"</b>	600 mm	<b>2'0"</b>
<b>9</b> Track gauge	2380 mm	<b>7'10"</b>	2380 mm	<b>7'10"</b>
<b>10</b> Transport width to outside of walkways	3256 mm	<b>10'8"</b>	3256 mm	<b>10'8"</b>

\*Excavator HDLC Undercarriage and 0.8 m (32") Riser.

\*\*Heavy-Duty High Forestry Undercarriage and 0.46 m (18") Riser.

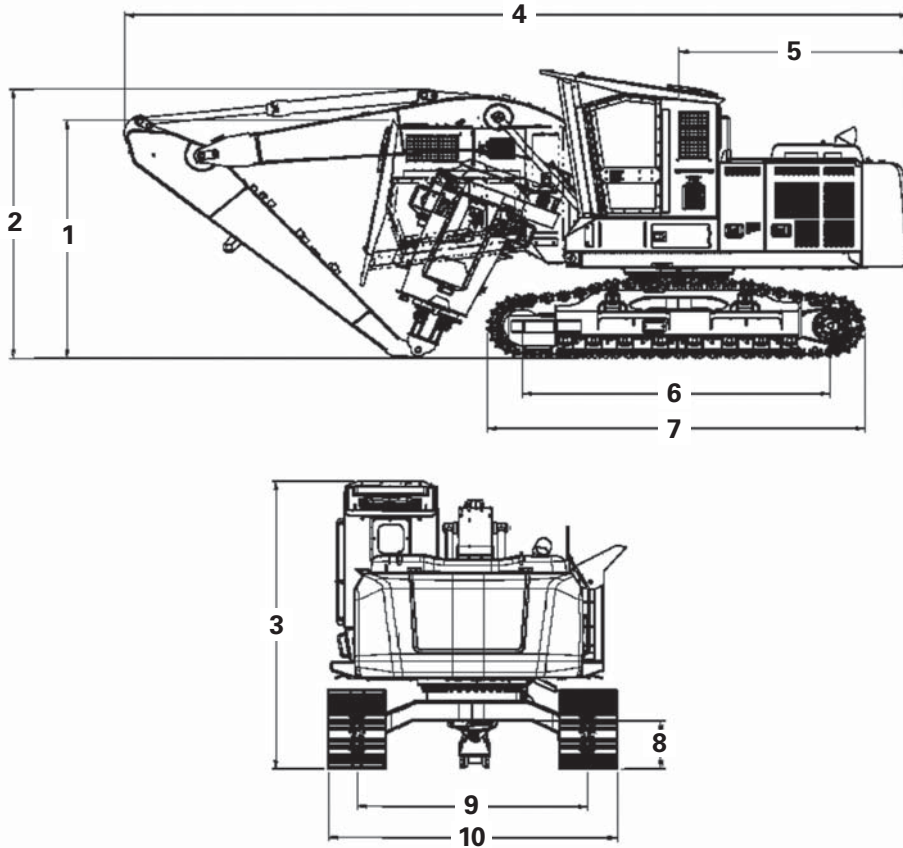

5

**538 General Forestry**

<b>1</b> Height – general forestry – cab tilted	3225 mm	<b>127.0"</b>
<b>2</b> Boom height – general forestry – shipping	3223 mm	<b>126.9"</b>
<b>3</b> Height – general forestry (overall)	3901 mm	<b>153.6"</b>
<b>4</b> Shipping length – general forestry (harvester)	9492 mm	<b>373.7"</b>
<b>5</b> Tail swing radius	2789 mm	<b>109.8"</b>
<b>6</b> Length to centers of rollers	3725 mm	<b>146.7"</b>
<b>7</b> Track length	4576 mm	<b>180.2"</b>
<b>8</b> Ground clearance	660 mm	<b>26.0"</b>
<b>9</b> Track gauge	2790 mm	<b>109.8"</b>
<b>10</b> Width – 700 mm (27.5") shoes	3490 mm	<b>137.4"</b>

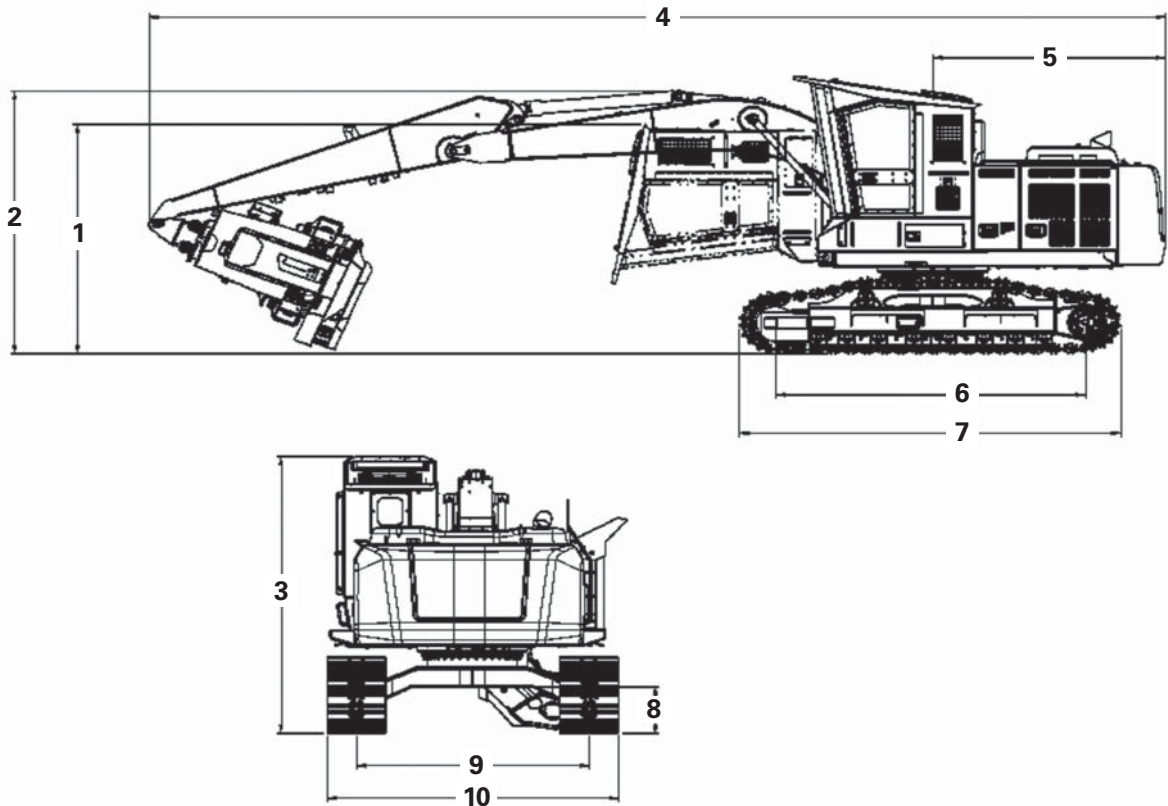

### 538 General Forestry

1	Height – general forestry – cab tilted	3225 mm	127.0"
2	Boom height – general forestry – shipping	3697 mm	145.6"
3	Height – general forestry (overall)	3901 mm	153.6"
4	Shipping length – general forestry (harvester)	12 192 mm	480.0"
5	Tail swing radius	2789 mm	109.8"
6	Length to centers of rollers	3725 mm	146.7"
7	Track length	4576 mm	180.2"
8	Ground clearance	660 mm	26.0"
9	Track gauge	2790 mm	109.8"
10	Width – 700 mm (27.5") shoes	3490 mm	137.4"

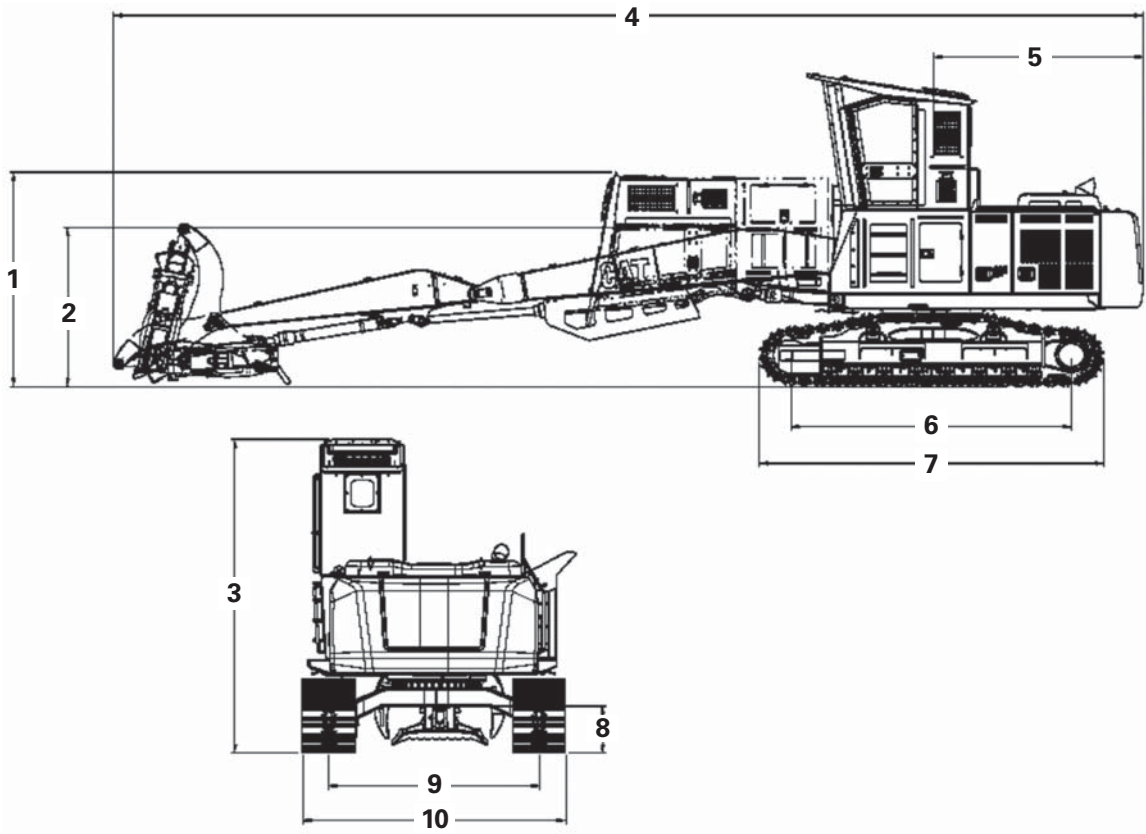

**538 Log Loader**

<b>1</b> Height – log loader – cab tilted	3142 mm	<b>123.7"</b>
<b>2</b> Boom height – log loader – shipping	2323 mm	<b>91.5"</b>
<b>3</b> Height – log loader (overall)	4578 mm	<b>180.2"</b>
<b>4</b> Shipping length – log loader (U/U)	13 485 mm	<b>530.9"</b>
<b>5</b> Tail swing radius	2789 mm	<b>109.8"</b>
<b>6</b> Length to centers of rollers	3725 mm	<b>146.7"</b>
<b>7</b> Track length	4576 mm	<b>180.2"</b>
<b>8</b> Ground clearance	660 mm	<b>26.0"</b>
<b>9</b> Track gauge	2790 mm	<b>109.8"</b>
<b>10</b> Width – 700 mm (27.5") shoes	3490 mm	<b>137.4"</b>

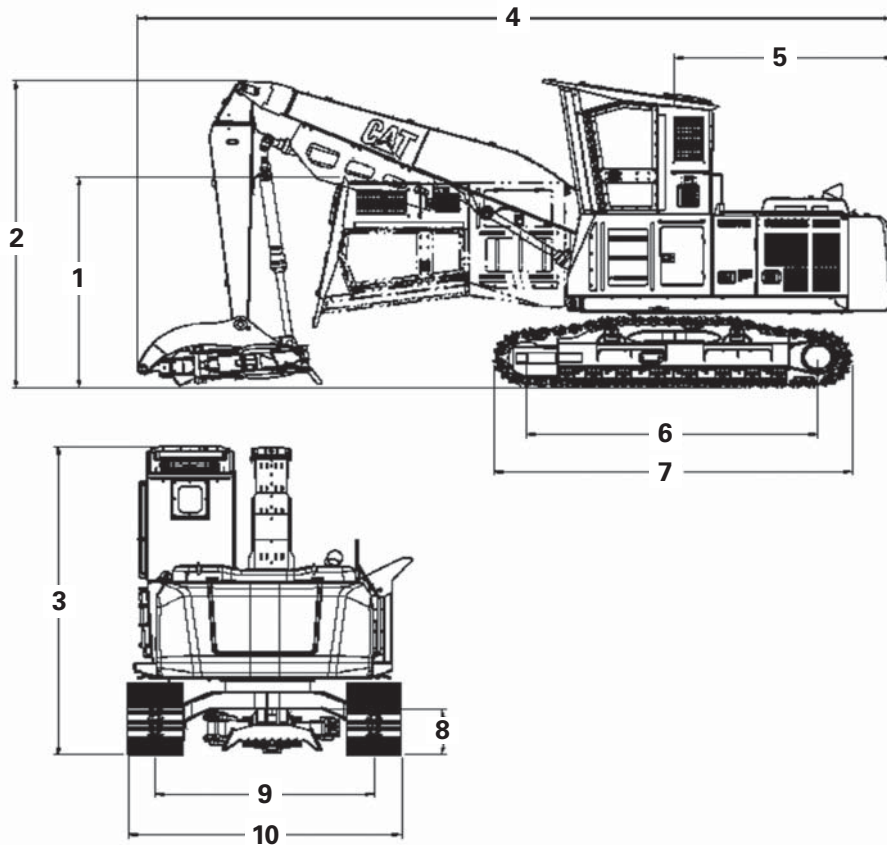

**538 Log Loader**

<b>1</b> Height — log loader — cab tilted	3142 mm	<b>123.7"</b>
<b>2</b> Boom height — log loader — shipping	4558 mm	<b>179.4"</b>
<b>3</b> Height — log loader (overall)	4578 mm	<b>180.2"</b>
<b>4</b> Shipping length — log loader (U/U)	9643 mm	<b>379.6"</b>
<b>5</b> Tail swing radius	2789 mm	<b>109.8"</b>
<b>6</b> Length to centers of rollers	3725 mm	<b>146.7"</b>
<b>7</b> Track length	4576 mm	<b>180.2"</b>
<b>8</b> Ground clearance	660 mm	<b>26.0"</b>
<b>9</b> Track gauge	2790 mm	<b>109.8"</b>
<b>10</b> Width — 700 mm (27.5") shoes	3490 mm	<b>137.4"</b>

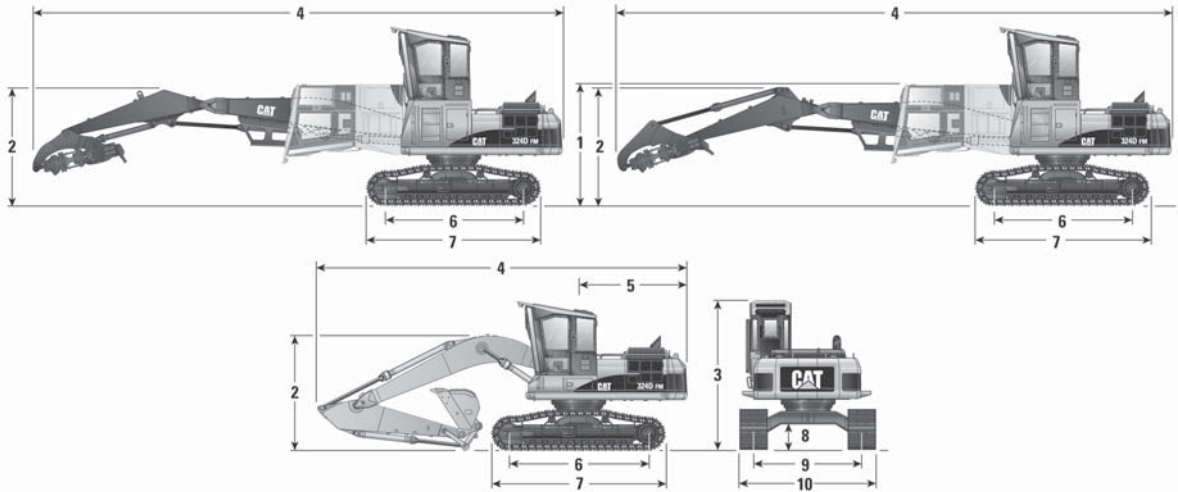

**324D FM General Forestry**

HW GF

<b>1</b> Shipping height (All risers with cab tilted)	3310 mm	<b>10'10"</b>
<b>2</b> Boom height	3170 mm	<b>10'5"</b>
<b>3</b> Overall height	4020 mm	<b>13'2"</b>
<b>4</b> Shipping length	9880 mm	<b>32'5"</b>
<b>5</b> Tail swing radius	2940 mm	<b>9'8"</b>
<b>6</b> Track length — idler to sprocket	4052 mm	<b>13'4"</b>
<b>7</b> Track length — total	4967 mm	<b>16'4"</b>
<b>8</b> Ground clearance	743 mm	<b>2'5"</b>
<b>9</b> Track gauge	2920 mm	<b>9'7"</b>
<b>10</b> Transport width with 700 mm (27.5") shoes (DG)	3620 mm	<b>11'11"</b>

**324D FM Log Loaders**

Under/Under

Over/Under

	Under/Under		Over/Under	
<b>1</b> Shipping height (All risers with cab tilted)	3310 mm	<b>10'10"</b>	3310 mm	<b>10'10"</b>
<b>2</b> Boom height	2780 mm	<b>9'1"</b>	2760 mm	<b>9'1"</b>
<b>3</b> Overall height	4790 mm	<b>15'9"</b>	4790 mm	<b>15'9"</b>
<b>4</b> Shipping length	14 080 mm	<b>46'2"</b>	14 990 mm	<b>49'2"</b>
<b>5</b> Tail swing radius	2940 mm	<b>9'8"</b>	2940 mm	<b>9'8"</b>
<b>6</b> Track length — idler to sprocket	4052 mm	<b>13'4"</b>	4052 mm	<b>13'4"</b>
<b>7</b> Track length — total	4967 mm	<b>16'4"</b>	4967 mm	<b>16'4"</b>
<b>8</b> Ground clearance	743 mm	<b>2'5"</b>	743 mm	<b>2'5"</b>
<b>9</b> Track gauge	2920 mm	<b>9'7"</b>	2920 mm	<b>9'7"</b>
<b>10</b> Transport width to steps with 700 mm (27.5") shoes (DG)	3620 mm	<b>11'11"</b>	3620 mm	<b>11'11"</b>

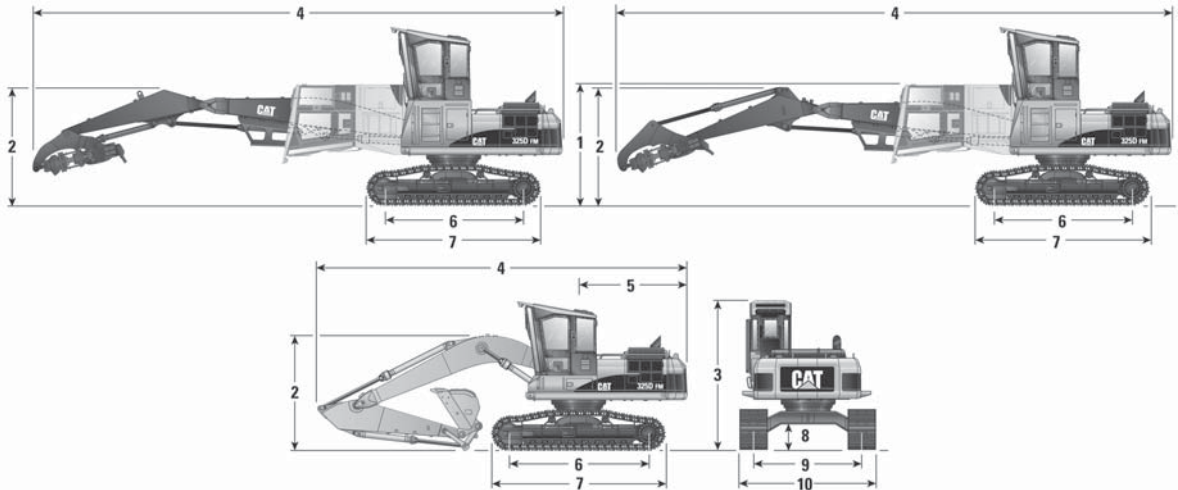

**325D FM General Forestry**

HW GF

<b>1</b> Shipping height (All risers with cab tilted)	3535 mm	<b>11'7"</b>
<b>2</b> Boom height	3310 mm	<b>10'10"</b>
<b>3</b> Overall height	4155 mm	<b>13'8"</b>
<b>4</b> Shipping length	10 260 mm	<b>33'8"</b>
<b>5</b> Tail swing radius	3020 mm	<b>9'11"</b>
<b>6</b> Track length — idler to sprocket	4020 mm	<b>13'2"</b>
<b>7</b> Track length — total	5060 mm	<b>16'7"</b>
<b>8</b> Ground clearance	767 mm	<b>2'6"</b>
<b>9</b> Track gauge	2920 mm	<b>9'7"</b>
<b>10</b> Transport width with 700 mm (27.5") shoes (DG)	3650 mm to steps	<b>12'0" to steps</b>

**325D FM Log Loaders**

Under/Under

Over/Under

<b>1</b> Shipping height (All risers with cab tilted)	3535 mm	<b>11'7"</b>	3535 mm	<b>11'7"</b>
<b>2</b> Boom height	2760 mm	<b>9'1"</b>	2740 mm	<b>9'0"</b>
<b>3</b> Overall height	4910 mm	<b>16'1"</b>	4910 mm	<b>16'1"</b>
<b>4</b> Shipping length	15 290 mm	<b>50'2"</b>	14 640 mm	<b>48'0"</b>
<b>5</b> Tail swing radius	3020 mm	<b>9'11"</b>	3020 mm	<b>9'11"</b>
<b>6</b> Track length — idler to sprocket	4020 mm	<b>13'2"</b>	4020 mm	<b>13'2"</b>
<b>7</b> Track length — total	5060 mm	<b>16'7"</b>	5060 mm	<b>16'7"</b>
<b>8</b> Ground clearance	767 mm	<b>2'6"</b>	767 mm	<b>2'6"</b>
<b>9</b> Track gauge	2920 mm	<b>9'7"</b>	2920 mm	<b>9'7"</b>
<b>10</b> Transport width with 700 mm (27.5") shoes (DG)	3650 mm to steps	<b>12'0" to steps</b>	3650 mm to steps	<b>12'0" to steps</b>

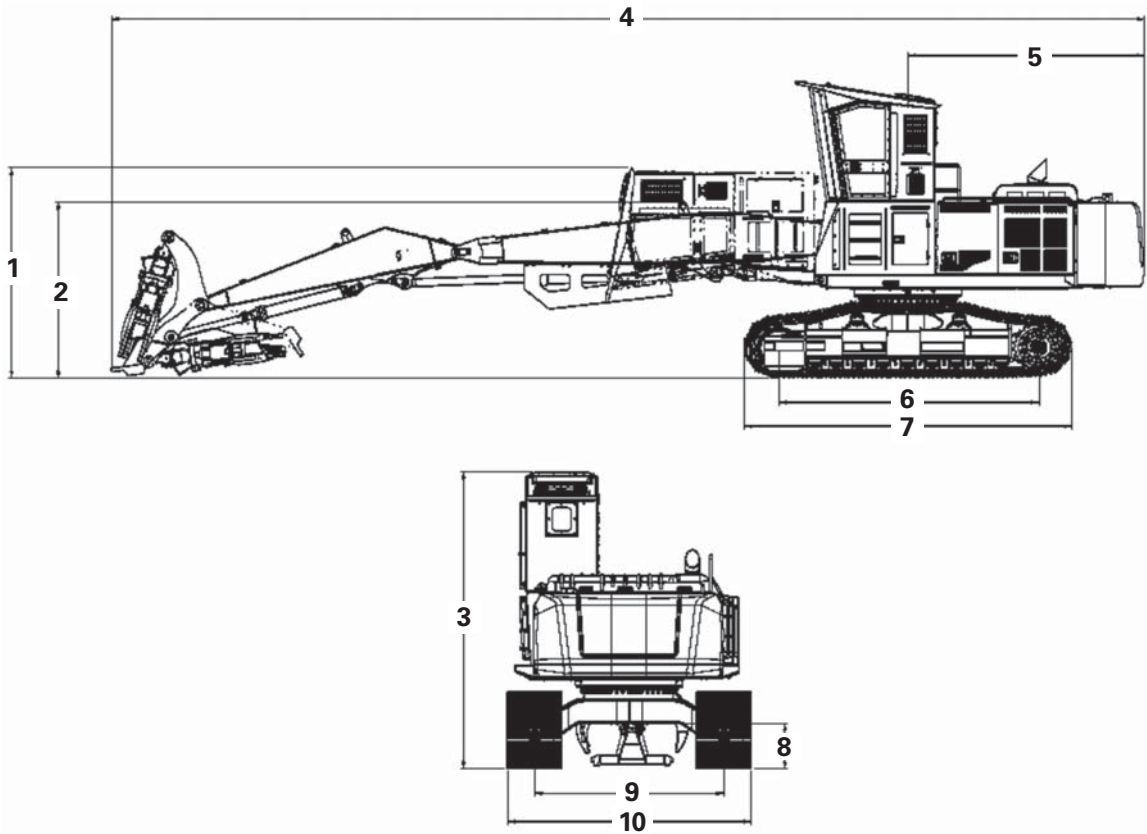

5

### 558 Log Loader

1 Height — log loader — cab tilted	3498 mm	137.7"
2 Boom height — log loader — shipping	2921 mm	115.0"
3 Height — log loader (overall)	4932 mm	194.2"
4 Shipping length — log loader (U/U)	15 967 mm	628.6"
5 Tail swing radius	3653 mm	143.8"
6 Length to centers of rollers	4019 mm	158.2"
7 Track length	5072 mm	199.7"
8 Ground clearance	749 mm	29.5"
9 Track gauge	2921 mm	115.0"
10 Width — 700 mm (27.5") shoes	3621 mm	142.6"



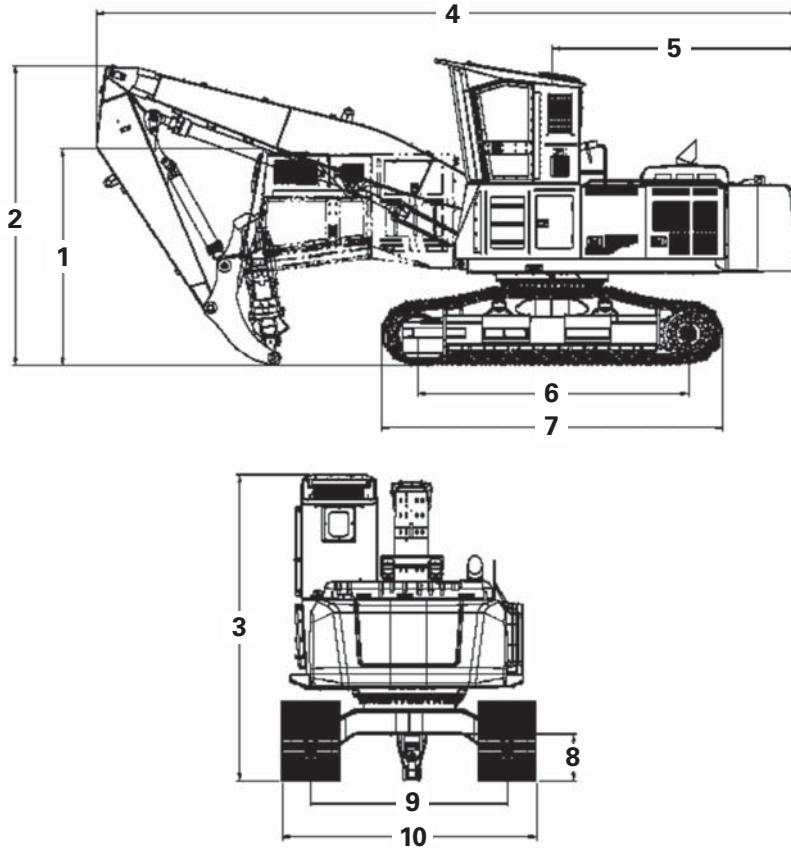

**558 Log Loader**

<b>1</b> Height — log loader — cab tilted	3498 mm	<b>137.7"</b>
<b>2</b> Boom height — log loader — shipping	4829 mm	<b>190.1"</b>
<b>3</b> Height — log loader (overall)	4932 mm	<b>194.2"</b>
<b>4</b> Shipping length — log loader (U/U)	10 423 mm	<b>410.4"</b>
<b>5</b> Tail swing radius	3653 mm	<b>143.8"</b>
<b>6</b> Length to centers of rollers	4019 mm	<b>158.2"</b>
<b>7</b> Track length	5072 mm	<b>199.7"</b>
<b>8</b> Ground clearance	749 mm	<b>29.5"</b>
<b>9</b> Track gauge	2921 mm	<b>115.0"</b>
<b>10</b> Width — 700 mm (27.5") shoes	3621 mm	<b>142.6"</b>

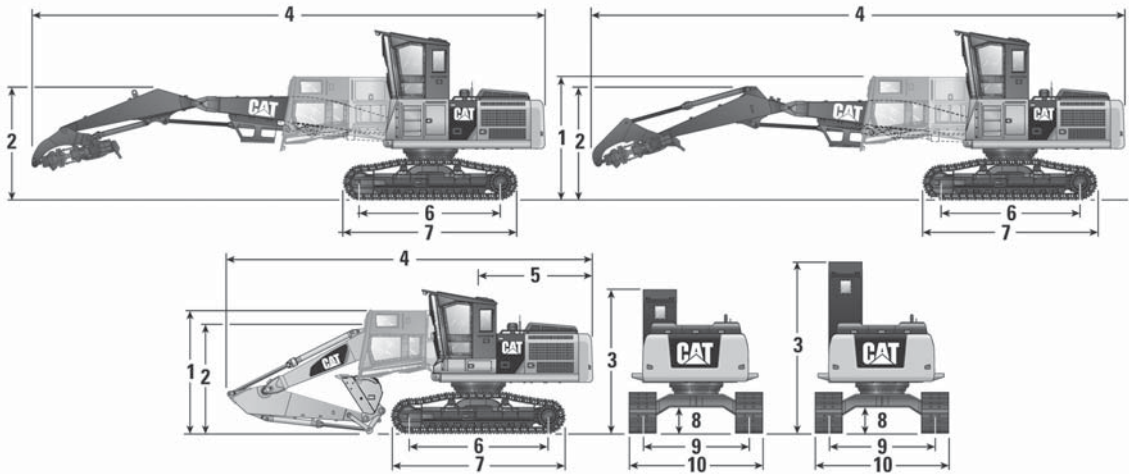

**568 FM General Forestry**

**HW GF**

<b>1</b> Shipping height (All risers with cab tilted)	3520 mm	<b>11'7"</b>
<b>2</b> Boom height	3520 mm	<b>11'7"</b>
<b>3</b> Overall height	4190 mm	<b>13'9"</b>
<b>4</b> Shipping length	10 780 mm	<b>35'5"</b>
<b>5</b> Tail swing radius	3460 mm	<b>11'4"</b>
<b>6</b> Track length — idler to sprocket	4356 mm	<b>14'3"</b>
<b>7</b> Track length — total	5390 mm	<b>17'7"</b>
<b>8</b> Ground clearance	760 mm	<b>2'6"</b>
<b>9</b> Track gauge	2920 mm	<b>9'7"</b>
<b>10</b> Transport width with 700 mm (27.5") shoes (DG)	3650 mm to steps	<b>12'0" to steps</b>

**568 FM Log Loaders**

**Under/Under**

**Over/Under**

<b>1</b> Shipping height (All risers with cab tilted)	3520 mm	<b>11'6"</b>	3520 mm	<b>11'6"</b>
<b>2</b> Boom height	3074 mm	<b>10'1"</b>	3074 mm	<b>10'1"</b>
<b>3</b> Overall height	4954 mm	<b>16'3"</b>	4954 mm	<b>16'3"</b>
<b>4</b> Shipping length	16 610 mm	<b>54'5"</b>	17 080 mm	<b>56'0"</b>
<b>5</b> Tail swing radius	3460 mm	<b>11'4"</b>	3460 mm	<b>11'4"</b>
<b>6</b> Track length — idler to sprocket	4356 mm	<b>14'3"</b>	4356 mm	<b>14'3"</b>
<b>7</b> Track length — total	5390 mm	<b>17'7"</b>	5390 mm	<b>17'7"</b>
<b>8</b> Ground clearance	760 mm	<b>2'6"</b>	760 mm	<b>2'6"</b>
<b>9</b> Track gauge	2920 mm	<b>9'7"</b>	2920 mm	<b>9'7"</b>
<b>10</b> Transport width with 700 mm (27.5") shoes (DG)	3650 mm to steps	<b>12'0" to steps</b>	3650 mm to steps	<b>12'0" to steps</b>

# Processing/Loading Trailer Mount Knuckleboom Loaders

## Features Specifications

### 529/559C/579C Features:

- **Advanced boom design technology** built tough with welded high-strength steel.
- **Booms** are engineered to withstand high production pull-through delimiting and loading.
- **Boom reach** ranges from 8.8 m (29 ft) on the 529 up to 10.9 m (36 ft) on the 579C.
- **Smooth and responsive joystick controls.**
- **Swing torque ratings** up to nearly 100 kN·m (73,700 lb-ft), combined with swing speeds up to 11 RPM.
- **Continuous rotation grapples** are constructed of wear resistant, high tensile steel with heavy-duty rotators designed for strenuous pull-through delimiting applications.

- **Heavy-duty sub-frames** are engineered for high reliability and stability.
- **Heavy duty off road axles** provide trouble free operation in the harsh woods environment.
- **Quiet, comfortable cabs** with excellent visibility.

Loaders offered with a factory matched performance package — The “DS” package is a complete factory installed timber merchandising system consisting of a knuckleboom loader and grapple, trailer with trailer mounted delimitter.

MODEL	529		559C		579C	
Gross Power	116.3 kW	<b>156 hp</b>	129.3 kW	<b>173 hp</b>	129.3 kW	<b>173 hp</b>
Engine	<b>C6.6 ACERT</b>		<b>C6.6 ACERT</b>		<b>C6.6 ACERT</b>	
Engine RPM	<b>2200</b>		<b>1800</b>		<b>1800</b>	
Operating Weight (with standard boom, less options, carrier & grapple)	12 655 kg	<b>27,900 lb</b>	15 558 kg	<b>34,300 lb</b>	16 674 kg	<b>36,760 lb</b>
Hydraulic System:						
System Pressure	18 960 kPa	<b>2750 psi</b>	24 131 kPa	<b>3500 psi</b>	24 131 kPa	<b>3500 psi</b>
Swing Pressure	18 271 kPa	<b>2650 psi</b>	24 131 kPa	<b>3500 psi</b>	24 131 kPa	<b>3500 psi</b>
Swing Speed	<b>8 RPM</b>		<b>11 RPM</b>		<b>9 RPM</b>	
Capacities:						
Fuel Capacity	276.3 L	<b>73 U.S. gal</b>	378.5 L	<b>100 U.S. gal</b>	378.5 L	<b>100 U.S. gal</b>
Hydraulic Capacity	295.3 L	<b>78 U.S. gal</b>	302.8 L	<b>80 U.S. gal</b>	302.9 L	<b>80 U.S. gal</b>
Counterweight	1496.8 kg	<b>3300 lb</b>	0 kg	<b>0 lb</b>	653.2 kg	<b>1440 lb</b>
Tailswing (with counterweight)	248.9 cm	<b>98"</b>	297.7 cm	<b>117.2"</b>	299.5 cm	<b>117.9"</b>
Knuckleboom Length	8.8 m	<b>29'0"</b>	9.75 m	<b>32'0"</b>	9.75 m	<b>32'0"</b>

**Basic Dimensions for 529, 559C and 579C**

(Loader trailer shown for dimensional reference only. Trailer is not included with loader.)

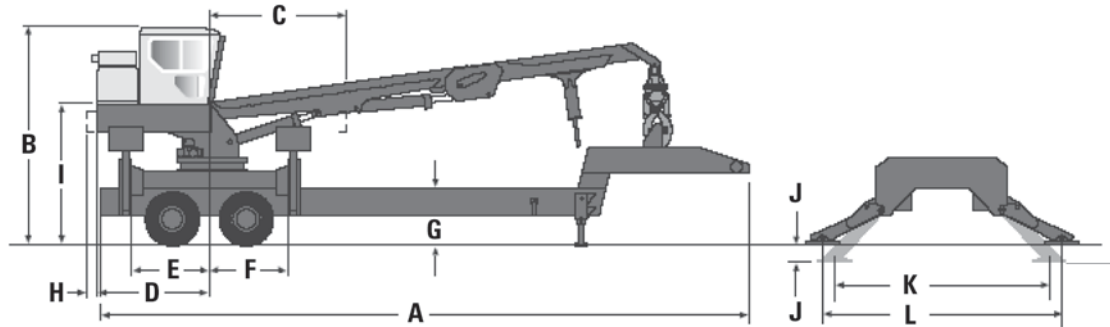

MODEL	529		559C		579C	
<b>A</b>	1219.2 cm	<b>480.00"</b>	1526.2 cm	<b>600.9"</b>	1526.2 cm	<b>600.9"</b>
<b>B</b>	404.5 cm	<b>159.25"</b>	400.2 cm	<b>157.6"</b>	400.2 cm	<b>157.6"</b>
<b>C*</b>	248.9 cm	<b>98.00"</b>	297.6 cm	<b>117.2"</b>	299.4 cm	<b>117.9"</b>
<b>D</b>	232.0 cm	<b>91.34"</b>	269.2 cm	<b>106.0"</b>	269.2 cm	<b>106.0"</b>
<b>E</b>	152.4 cm	<b>60.00"</b>	166.9 cm	<b>65.7"</b>	166.9 cm	<b>65.7"</b>
<b>F</b>	152.4 cm	<b>60.00"</b>	166.9 cm	<b>65.7"</b>	166.9 cm	<b>65.7"</b>
<b>G</b>	99.1 cm	<b>39.00"</b>	99.1 cm	<b>39.0"</b>	99.1 cm	<b>39.0"</b>
<b>H**</b>	24.1 cm	<b>9.50"</b>	0 cm	<b>0"</b>	5.7 cm	<b>2.3"</b>
<b>I</b>	246.4 cm	<b>97.00"</b>	246.8 cm	<b>97.2"</b>	246.8 cm	<b>97.2"</b>
<b>J</b>	36.0 cm	<b>14.18"</b>	43.3 cm	<b>17.0"</b>	43.3 cm	<b>17.0"</b>
<b>K</b>	392.0 cm	<b>154.35"</b>	423.7 cm	<b>166.8"</b>	423.7 cm	<b>166.8"</b>
<b>L</b>	447.0 cm	<b>176.00"</b>	475.3 cm	<b>187.3"</b>	475.8 cm	<b>187.3"</b>

\*Maximum tailswing.  
\*\*Add for counterweight.

# Processing/Loading Trailer Mount Knuckleboom Loaders

## Lift and Range Diagram ● 529 Knuckleboom Loader

### 529 Knuckleboom Loader 8.8 m (29'0") Boom

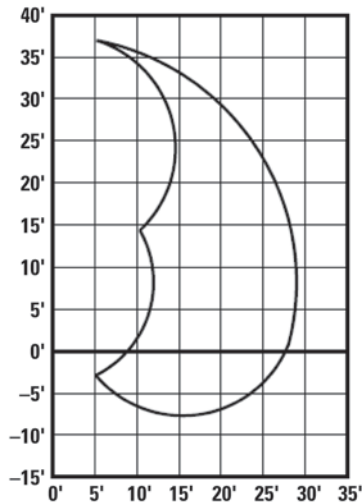

#### NOTES:

Do not attempt to lift or hold any load that is greater than the rated values over the end or side. The weight of the grapple and all lifting accessories must be deducted from lift capacities shown.

1. The over end capacities and over side capacities do not exceed 87% of hydraulic limited capacity or 75% of stability limited capacity.  
– Stability limited capacities are indicated with an asterisk (\*).
2. The lift point is located at the grapple knuckle pin.
3. Lift capacities are based on the machine standing on firm, uniform supporting surface. User must make allowances for job site conditions.
4. Operator should be fully acquainted with the Operator's Manual and all safety instructions furnished by Caterpillar Inc. prior to operating the machine.
5. Lift capacities are in compliance with SAE J2417, "Lift Capacity Calculation Method – Knuckleboom Log Loaders and Certain Forestry Equipment."

	3 m/10'0"		4.6 m/15'0"		6.1 m/20'0"		7.6 m/25'0"		Maximum Reach		
	kg	lb	kg	lb	kg	lb	kg	lb	kg	lb	
9.1 m (30'0")			5591.9 4864.8 4864.8	<b>12,328</b> <b>10,725</b> <b>10,725</b>							100% Hydraulics Over End Over Side
7.6 m (25'0")			5854.1 5093.1 5093.1	<b>12,906</b> <b>11,228</b> <b>11,228</b>	5136.6 4468.8 4468.8	<b>11,324</b> <b>9,852</b> <b>9,852</b>					100% Hydraulics Over End Over Side
6.1 m (20'0")			5896.7 5130.2 5130.2	<b>13,000</b> <b>11,310</b> <b>11,310</b>	5481.7 4769.2 4769.2	<b>12,085</b> <b>10,514</b> <b>10,514</b>	4159.5 3618.8 3618.8	<b>9,170</b> <b>7,978</b> <b>7,978</b>			100% Hydraulics Over End Over Side
4.6 m (15'0")			6384.8 5554.7 5554.7	<b>14,076</b> <b>12,246</b> <b>12,246</b>	5641.8 4908.4 4908.4	<b>12,438</b> <b>10,821</b> <b>10,821</b>	4650.8 4046.1 4046.1	<b>10,253</b> <b>8,920</b> <b>8,920</b>	2379.5 2070.2 2070.2	<b>5,246</b> <b>4,564</b> <b>4,564</b>	100% Hydraulics Over End Over Side
3.0 m (10'0")			7557.4 6574.8 6574.8	<b>16,661</b> <b>14,495</b> <b>14,495</b>	6542.2 5691.7 5691.7	<b>14,423</b> <b>12,548</b> <b>12,548</b>	5072.6 4413.1 4413.1	<b>11,183</b> <b>9,729</b> <b>9,729</b>	2344.2 2039.4 2039.4	<b>5,168</b> <b>4,496</b> <b>4,496</b>	100% Hydraulics Over End Over Side
1.5 m (5'0")			8857.8 7706.2 7706.2	<b>19,528</b> <b>16,989</b> <b>16,989</b>	6573.1 5718.5 5718.5	<b>14,491</b> <b>12,607</b> <b>12,607</b>	4963.7 4318.2 4318.2	<b>10,943</b> <b>9,520</b> <b>9,520</b>	2355.9 2049.8 2049.8	<b>5,194</b> <b>4,519</b> <b>4,519</b>	100% Hydraulics Over End Over Side
0 m (0'0")	6924.5 6024.2 6024.2	<b>15,266</b> <b>13,281</b> <b>13,281</b>	8425.6 7330.2 7330.2	<b>18,575</b> <b>16,160</b> <b>16,160</b>	6101.3 5308.1 5308.1	<b>13,451</b> <b>11,702</b> <b>11,702</b>	4259.8 3705.9 3705.9	<b>9,391</b> <b>8,170</b> <b>8,170</b>			100% Hydraulics Over End Over Side
-1.5 m (-5'0")	7980.1 6942.8 6942.8	<b>17,593</b> <b>15,306</b> <b>15,306</b>	6807.2 5922.2 5922.2	<b>15,007</b> <b>13,056</b> <b>13,056</b>	4782.3 4160.4 4160.4	<b>10,543</b> <b>9,172</b> <b>9,172</b>					100% Hydraulics Over End Over Side

# Lift and Range Diagram ● 559C Knuckleboom Loader

# Processing/Loading Trailer Mount Knuckleboom Loaders

## 559C Knuckleboom Loader 9.8 m (32'0") Boom

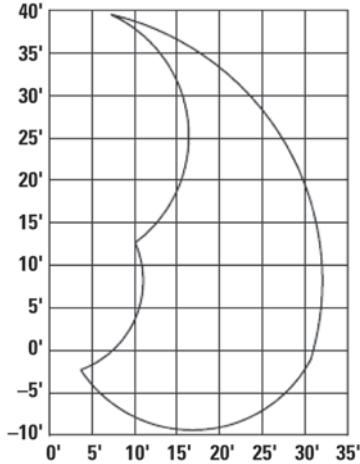

### NOTES:

Do not attempt to lift or hold any load that is greater than the rated values over the end or side. The weight of the grapple and all lifting accessories must be deducted from lift capacities shown.

1. The over end capacities and over side capacities do not exceed 87% of hydraulic limited capacity or 75% of stability limited capacity.  
– Stability limited capacities are indicated with an asterisk (\*).
2. The lift point is located at the grapple knuckle pin.
3. Lift capacities are based on the machine standing on firm, uniform supporting surface. User must make allowances for job site conditions.
4. Operator should be fully acquainted with the Operator's Manual and all safety instructions furnished by Caterpillar Inc. prior to operating the machine.
5. Lift capacities are in compliance with SAE J2417, "Lift Capacity Calculation Method – Knuckleboom Log Loaders and Certain Forestry Equipment."

	3 m/10'0"		4.6 m/15'0"		6.1 m/20'0"		7.6 m/25'0"		9.1 m/30'0"		Maximum Reach		
	kg	lb	kg	lb	kg	lb	kg	lb	kg	lb	kg	lb	
10.6 m (35'0")			6253.7 5441.0 5441.0	<b>13,805.0</b> <b>12,011.0</b> <b>12,011.0</b>									100% Hydraulics Over End Over Side
9.1 m (30'0")					5898.5 5131.6 5131.6	<b>13,021</b> <b>11,328</b> <b>11,328</b>							100% Hydraulics Over End Over Side
7.6 m (25'0")					6089.7 5298.3 5298.3	<b>13,443</b> <b>11,696</b> <b>11,696</b>	5588.7 4569.0 4569.0	<b>12,337</b> <b>10,086</b> <b>10,086</b>					100% Hydraulics Over End Over Side
6.1 m (20'0")					6235.5 5425.1 5425.1	<b>13,765</b> <b>11,976</b> <b>11,976</b>	5751.3 4862.0 4862.0	<b>12,696</b> <b>10,733</b> <b>10,733</b>					100% Hydraulics Over End Over Side
4.6 m (15'0")			7849.6 6829.0 6829.0	<b>17,328</b> <b>15,075</b> <b>15,075</b>	6658.6 5793.0 5793.0	<b>14,699</b> <b>12,788</b> <b>12,788</b>	6541.8 5003.8 5003.8	<b>14,441</b> <b>11,046</b> <b>11,046</b>	4809.0 4183.9 3665.6*	<b>10,616</b> <b>9236</b> <b>8092*</b>			100% Hydraulics Over End Over Side
3.0 m (10'0")			9117.5 7932.0 7932.0	<b>20,127</b> <b>17,510</b> <b>17,510</b>	7891.7 6865.7 6865.7	<b>17,421</b> <b>15,156</b> <b>15,156</b>	6660.0 5691.0 5017.9*	<b>14,702</b> <b>12,563</b> <b>11,077*</b>	4922.8 4282.7 3606.8*	<b>10,867</b> <b>9454</b> <b>7962*</b>	3578.7 3113.5 3113.5	<b>7900</b> <b>6873</b> <b>6873</b>	100% Hydraulics Over End Over Side
1.5 m (5'0")			11152.4 9702.8 9702.8	<b>24,619</b> <b>21,419</b> <b>21,419</b>	8385.0 7295.1 7235.3*	<b>18,510</b> <b>16,104</b> <b>15,972*</b>	6660.0 5794.3 4852.5	<b>14,702</b> <b>12,791</b> <b>10,712*</b>	4749.3 4131.8 3538.4	<b>10,484</b> <b>9121</b> <b>7811*</b>			100% Hydraulics Over End Over Side
0 m (0'0")	9419.2 8194.8 8194.8	<b>20,793</b> <b>18,090</b> <b>18,090</b>	11478.1 9985.9 9985.9	<b>25,338</b> <b>22,044</b> <b>22,044</b>	8419.9 7325.5 6951.3	<b>18,587</b> <b>16,171</b> <b>15,345*</b>	6439.4 5602.3 4719.4	<b>14,215</b> <b>12,367</b> <b>10,418*</b>	4231.9 3681.5 3494.9	<b>9342</b> <b>8127</b> <b>7715*</b>			100% Hydraulics Over End Over Side
-1.5 m (-5'0")	8938.1 7776.2 7776.2	<b>19,731</b> <b>17,166</b> <b>17,166</b>	10516.8 9149.7 9149.7	<b>23,216</b> <b>20,198</b> <b>20,198</b>	7672.5 6675.0 6511.9*	<b>16,937</b> <b>14,735</b> <b>14,375*</b>	5566.0 4842.6 4657.3*	<b>12,287</b> <b>10,690</b> <b>10,281*</b>					100% Hydraulics Over End Over Side

# Processing/Loading Trailer Mount Knuckleboom Loaders

## Lift and Range Diagram ● 579C Knuckleboom Loader

### 579C Knuckleboom Loader 9.9 m (32'6") Boom

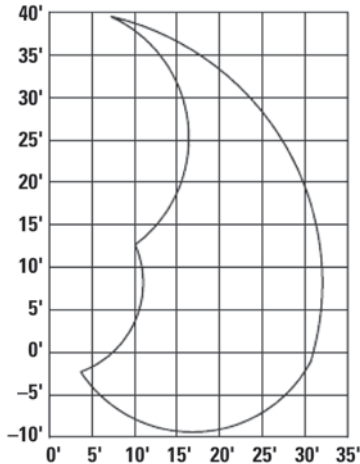

#### NOTES:

Do not attempt to lift or hold any load that is greater than the rated values over the end or side. The weight of the grapple and all lifting accessories must be deducted from lift capacities shown.

1. The over end capacities and over side capacities do not exceed 87% of hydraulic limited capacity or 75% of stability limited capacity.  
– Stability limited capacities are indicated with an asterisk (\*).
2. The lift point is located at the grapple knuckle pin.
3. Lift capacities are based on the machine standing on firm, uniform supporting surface. User must make allowances for job site conditions.
4. Operator should be fully acquainted with the Operator's Manual and all safety instructions furnished by Caterpillar Inc. prior to operating the machine.
5. Lift capacities are in compliance with SAE J2417, "Lift Capacity Calculation Method – Knuckleboom Log Loaders and Certain Forestry Equipment."

	3 m/10'0"		4.6 m/15'0"		6.1 m/20'0"		7.6 m/25'0"		9.1 m/30'0"		Maximum Reach		
	kg	lb	kg	lb	kg	lb	kg	lb	kg	lb	kg	lb	
10.6 m (35'0")			7455.0 6485.6 6485.6	16,457.0 14,317.0 14,317.0									100% Hydraulics Over End Over Side
9.1 m (30'0")					7039.2 6124.1 6124.1	15,539 13,519 13,519							100% Hydraulics Over End Over Side
7.6 m (25'0")					7233.5 6293.1 6293.1	15,968 13,892 13,892	6280.8 5464.5 5464.5	13,865 12,063 12,063					100% Hydraulics Over End Over Side
6.1 m (20'0")					7412.0 6448.5 6448.5	16,362 14,235 14,235	6695.8 5845.5 5845.5	14,781 12,860 12,860					100% Hydraulics Over End Over Side
4.6 m (15'0")			9268.8 8063.9 8063.9	20,461 17,801 17,801	7929.3 6898.7 6898.7	17,504 15,229 15,229	6898.3 6001.3 5748.2*	15,228 13,248 12,646*	5761.7 5012.9 4108.6*	12,719 11,066 9039*			100% Hydraulics Over End Over Side
3.0 m (10'0")			10 887.4 9471.8 9471.8	24,034 20,909 20,909	9338.1 8124.1 8124.1	20,614 17,934 17,934	7782.5 6771.0 5592.3*	17,180 14,947 12,303*	5958.8 5184.1 4049.1*	13,154 11,444 8908*	4318.0 3756.7 3609.1*	9532 8293 7940*	100% Hydraulics Over End Over Side
1.5 m (5'0")			13 174.1 11 461.4 11 461.4	29,082 25,301 25,301	9947.4 8654.6 8045.0*	21,959 19,105 17,699*	7940.6 6908.3 5424.1*	17,529 15,250 11,933*	5767.1 5017.4 3980*	12,731 11,076 8756*			100% Hydraulics Over End Over Side
0 m (0'0")	12 569.8 10 935.4 10 935.4	27,748 24,140 24,140	13 608.6 11 839.2 11 839.2	30,041 26,135 26,135	10 020.4 8717.5 7757.3*	22,120 19,244 17,066*	7702.8 6701.7 5289.5*	17,004 14,794 11,637*	5118.9 4453.4 3935.5*	11,300 9831 8658*			100% Hydraulics Over End Over Side
-1.5 m (-5'0")	11 940.2 10 387.7 10 387.7	26,358 22,931 22,931	12 527.3 10 898.7 10 898.7	27,654 24,059 24,059	9174.6 7981.9 7601.4*	20,253 17,620 16,723*	6702.6 5831.5 5226.8*	14,796 12,873 11,499*					100% Hydraulics Over End Over Side

**519/569 Features:**

- **Heavy-duty boom options** range in length from 8.2 m (27 ft) to 10.90 m (36 ft) for handling a variety of tree lengths.
- **Weatherproof electric service panels** include starters, controls, transformers, circuit breakers and fuse blocks.
- **Electric motors** are rated for severe duty.
- **Resilient Pad Mounting System** includes a set of special rubber isolators on each mounting fastener that absorbs stress in two directions.
- **Hydraulic pilot joystick controls and rocker swing pedal** are ergonomically designed for ease of operation and maximum loader control.

MODEL	519 SM		519 SM/EHC		569 SM		569 SM/EHC	
Electric Power Supply (standard)	460 Volt: 60 Hz		460 Volt: 60 Hz		460 Volt: 60 Hz		460 Volt: 60 Hz	
Electric Power Supply (optional)*	575 Volt: 60 Hz		575 Volt: 60 Hz		575 Volt: 60 Hz		575 Volt: 60 Hz	
Electric Motor @ 1800 RPM	56 kW	75 hp	56 kW	75 hp	74 kW	100 hp	74 kW	100 hp
Operating Weight	7218.9 kg	15,915 lb	6946.7 kg	15,315 lb	8593.3 kg	18,945 lb	8321.1 kg	18,345 lb
Hydraulic System:								
System Pressure	15 168 kPa	2200 psi	15 168 kPa	2200 psi	17 237 kPa	2500 psi	17 237 kPa	2500 psi
Swing Pressure	16 547 kPa	2400 psi	16 547 kPa	2400 psi	17 237 kPa	2500 psi	17 237 kPa	2500 psi
Swing Speed	8 RPM		8 RPM		7 RPM		7 RPM	
Knuckleboom Length (standard)	8.2 m	27'0"	8.2 m	27'0"	9.9 m	32'6"	9.9 m	32'6"
Knuckleboom Length (optional)	9.1 m	30'0"	9.1 m	30'0"	11.0 m	36'0"	11.0 m	36'0"

\*NOTE: Other Electric Power options available by special quote.

**Electrical Code Requirements:**

Cat Electric Stationary Mount Loaders are designed to meet National Electrical Code (NEC) requirements in the United States. However, the Dealer/Customer is responsible to investigate local Electrical Code requirements that may exist and make updates as required to the machine to meet additional local requirements.

**Incoming Supply Power Requirements for the Stationary Mount Loaders:**

Incoming supply power specification for all stationary mount loaders must be within  $\pm 5\%$  of nominal for proper operation/reliability of the machine. A customer/dealer supplied transformer must be installed to accommodate the incoming power requirements if needed.



# Millyards Stationary Mount Knuckleboom Loaders

## Dimensions

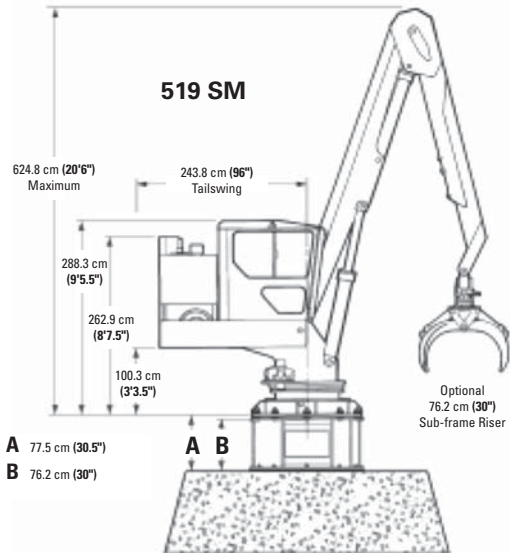

**NOTE:** Overall height dimension to 8.2 m (27'0") boom articulation point is taken with main boom cylinder fully extended. Add 76.2 cm (30") to this dimension for 9.1 m (30'0") knuckleboom.

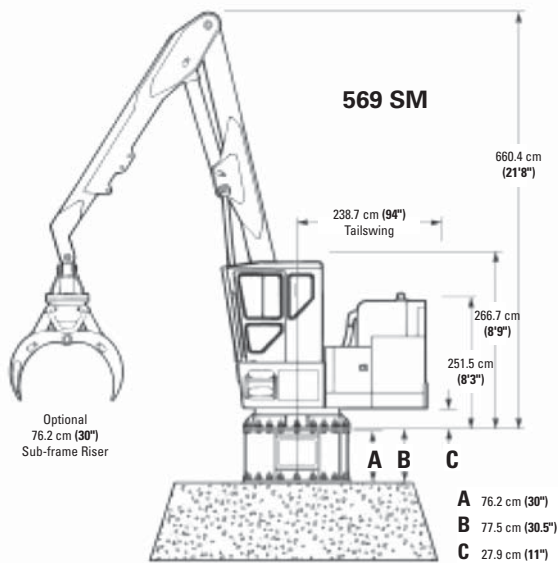

**NOTE:** Overall height dimension to 9.1 m (30'0") boom articulation point is taken with main boom cylinder fully extended. Add 106.9 cm (42") to this dimension for 10.9 m (36'0") knuckleboom.

## Resilient Pad System

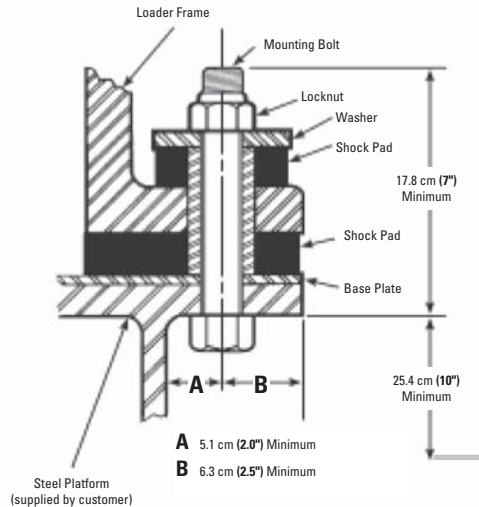

- Operator's cab is not present on EHC models.
- EHC models available with Remote Power Packs.
- Installations on concrete include "J" Bolts in lieu of Mounting Bolt.
- Continuous rotation units require 76.2 cm (30") minimum working clearance beneath subframe or collector ring and wiring maintenance.
- The customer is responsible for the design and engineering of all mounting systems and Caterpillar Forest Products recommends that the customer employs an engineer to perform this work.
- For additional installation guidelines refer to the Steel or Concrete information drawing for the stationary mount loader being installed. These information drawings along with engineering data to assist in the design of the support structure for the stationary mount loader are available from Caterpillar Forest Products upon request by the authorized dealer.

Lift and Range Diagram  
 ● 519 SM Knuckleboom Loader  
 ● 519 SM/EHC Knuckleboom Loader

**Millyards  
 Stationary Mount  
 Knuckleboom Loaders**

**519 SM/519 SM/EHC  
 8.2 m (27'0") Boom**

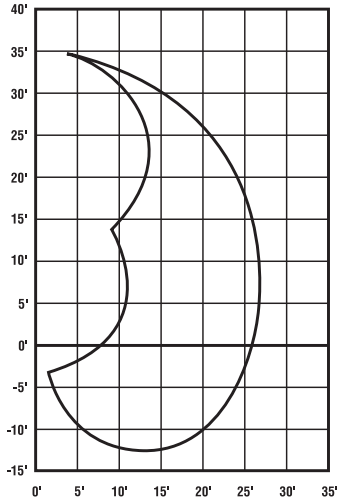

**NOTES:**

Do not attempt to lift or hold any load that is greater than the rated values over the end or side at their specified lift point and height. The weight of the grapple and all lifting accessories must be deducted from lift capacities shown.

1. All figures shown in these charts represent rated lift capacities.
2. Capacities shown in *italic* are 100% of hydraulic capacity; other capacities shown are 87% of hydraulic capability.
3. The lift point is located at the boom/grapple pivot pin.
4. Manufacturer assumes no responsibility for the proper fit or structural integrity of the mounting pedestal and/or platform supplied by the customer.
5. Operator should be fully acquainted with the Operator's Manual and all safety instructions furnished prior to operating the machine.
6. Lift capacities are in compliance with SAE J2417, "Lift Capacity Calculation Method – Knuckleboom Log Loaders and Certain Forestry Equipment."

	1.5 m/5'0"		3 m/10'0"		4.6 m/15'0"		6.1 m/20'0"		7.6 m/25'0"	
	kg	lb	kg	lb	kg	lb	kg	lb	kg	lb
7.6 m (25'0")					5021 4368	<i>11,060</i> <i>9,622</i>				
6.1 m (20'0")					5177 4504	<i>11,402</i> <i>9,920</i>	4486 3903	<i>9,882</i> <i>8,597</i>		
4.6 m (15'0")					5311 4620	<i>11,698</i> <i>10,177</i>	4634 4032	<i>10,207</i> <i>8,880</i>		
3.0 m (10'0")			3788 3295	<i>8,343</i> <i>7,258</i>	5854 5093	<i>12,894</i> <i>11,218</i>	4799 4175	<i>10,571</i> <i>9,197</i>	3962 3447	<i>8,728</i> <i>7,593</i>
1.5 m (5'0")					7229 6289	<i>15,923</i> <i>13,853</i>	5951 5177	<i>13,107</i> <i>11,403</i>	3890 3384	<i>8,568</i> <i>7,454</i>
0 m (0'0")					8730 6603	<i>19,229</i> <i>16,729</i>	6469 5628	<i>14,249</i> <i>12,397</i>	4061 3533	<i>8,946</i> <i>7,783</i>
-1.5 m (-5'0")			4764 4145	<i>10,494</i> <i>9,130</i>	8057 7010	<i>17,747</i> <i>15,440</i>	5811 5056	<i>12,800</i> <i>11,136</i>	3040 2645	<i>6,697</i> <i>5,826</i>
-3.0 m (-10'0")	3050 2654	<i>6,718</i> <i>5,845</i>	6276 5460	<i>13,824</i> <i>12,027</i>	6152 5353	<i>13,552</i> <i>11,790</i>	4083 3552	<i>8,993</i> <i>7,824</i>		
-4.6 m (-15'0")			3494 3040	<i>7,697</i> <i>6,696</i>	2564 2231	<i>5,648</i> <i>4,914</i>				

# Millyards Stationary Mount Knuckleboom Loaders

- ## Lift and Range Diagram
- 519 SM Knuckleboom Loader
  - 519 SM/EHC Knuckleboom Loader

### 519 SM/519 SM/EHC 9.1 m (30'0") Boom

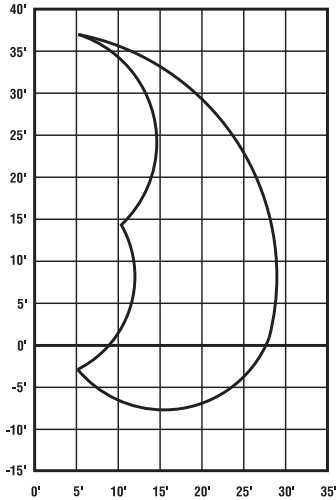

#### NOTES:

Do not attempt to lift or hold any load that is greater than the rated values over the end or side at their specified lift point and height. The weight of the grapple and all lifting accessories must be deducted from lift capacities shown.

1. All figures shown in these charts represent rated lift capacities.
2. Capacities shown in *italic* are 100% of hydraulic capacity; other capacities shown are 87% of hydraulic capability.
3. The lift point is located at the boom/grapple pivot pin.
4. Manufacturer assumes no responsibility for the proper fit or structural integrity of the mounting pedestal and/or platform supplied by the customer.
5. Operator should be fully acquainted with the Operator's Manual and all safety instructions furnished prior to operating the machine.
6. Lift capacities are in compliance with SAE J2417, "Lift Capacity Calculation Method – Knuckleboom Log Loaders and Certain Forestry Equipment."

	1.5 m/5'0"		3 m/10'0"		4.6 m/15'0"		6.1 m/20'0"		7.6 m/25'0"		9.1 m/30'0"	
	kg	lb	kg	lb	kg	lb	kg	lb	kg	lb	kg	lb
9.1 m (30'0")					4206 3659	<i>9,264</i> <i>8,060</i>						
7.6 m (25'0")					4714 4101	<i>10,384</i> <i>9,034</i>	3940 3428	<i>8,679</i> <i>7,551</i>				
6.1 m (20'0")							4179 3636	<i>9,206</i> <i>8,009</i>	3088 2687	<i>6,802</i> <i>5,918</i>		
4.6 m (15'0")					4419 3845	<i>9,734</i> <i>8,469</i>	4267 3712	<i>9,398</i> <i>8,176</i>	3713 3230	<i>8,178</i> <i>7,115</i>		
3.0 m (10'0")					4942 4300	<i>10,886</i> <i>9,471</i>	4488 3904	<i>9,885</i> <i>8,600</i>	3769 3279	<i>8,301</i> <i>7,222</i>		
1.5 m (5'0")					6380 5551	<i>14,053</i> <i>12,226</i>	5670 4933	<i>12,490</i> <i>10,866</i>	4407 3834	<i>9,707</i> <i>8,445</i>	1996 1737	<i>4,397</i> <i>3,825</i>
0 m (0'0")					8448 7350	<i>18,608</i> <i>16,189</i>	6299 5480	<i>13,874</i> <i>12,070</i>	4873 4239	<i>10,733</i> <i>9,338</i>		
-1.5 m (-5'0")			2892 2516	<i>6,369</i> <i>5,541</i>	7983 6945	<i>17,583</i> <i>15,297</i>	5894 5128	<i>12,983</i> <i>11,295</i>	4320 3758	<i>9,515</i> <i>8,278</i>		
-3.0 m (-10'0")	2039 1774	<i>4,492</i> <i>3,908</i>	4532 3943	<i>9,983</i> <i>8,685</i>	6538 5688	<i>14,401</i> <i>12,529</i>	4775 4154	<i>10,517</i> <i>9,150</i>	2937 2556	<i>6,470</i> <i>5,629</i>		
-4.6 m (-15'0")			4942 4299	<i>10,885</i> <i>9,470</i>	3981 3463	<i>8,768</i> <i>7,628</i>	2518 2191	<i>5,547</i> <i>4,826</i>				

- 569 SM Knuckleboom Loader
- 569 SM/EHC Knuckleboom Loader

## Millyards Stationary Mount Knuckleboom Loaders

### 569 SM/569 SM/EHC 9.6 m (32'6") Boom

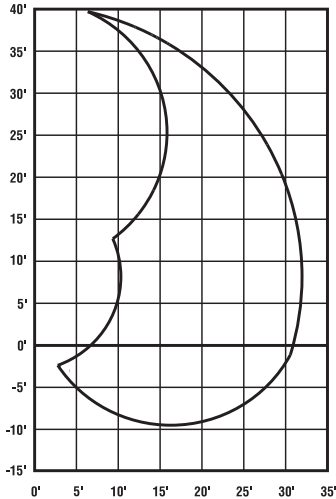

#### NOTES:

Do not attempt to lift or hold any load that is greater than the rated values over the end or side at their specified lift point and height. The weight of the grapple and all lifting accessories must be deducted from lift capacities shown.

1. All figures shown in these charts represent rated lift capacities.
2. Capacities shown in *italic* are 100% of hydraulic capacity; other capacities shown are 87% of hydraulic capability.
3. The lift point is located at the boom/grapple pivot pin.
4. Manufacturer assumes no responsibility for the proper fit or structural integrity of the mounting pedestal and/or platform supplied by the customer.
5. Operator should be fully acquainted with the Operator's Manual and all safety instructions furnished prior to operating the machine.
6. Lift capacities are in compliance with SAE J2417, "Lift Capacity Calculation Method – Knuckleboom Log Loaders and Certain Forestry Equipment."

5

	1.5 m/5'0"		3 m/10'0"		4.6 m/15'0"		6.1 m/20'0"		7.6 m/25'0"		9.1 m/30'0"	
	kg	lb	kg	lb	kg	lb	kg	lb	kg	lb	kg	lb
9.1 m (30'0")												
7.6 m (25'0")							5118 4453	<i>11,274</i> <i>9,808</i>				
6.1 m (20'0")							5850 5089	<i>12,885</i> <i>11,210</i>	4577 3982	<i>10,082</i> <i>8,771</i>		
4.6 m (15'0")							6422 5587	<i>14,145</i> <i>12,306</i>	5560 4837	<i>12,247</i> <i>10,655</i>	2997 2607	<i>6,601</i> <i>5,743</i>
3.0 m (10'0")					7558 6575	<i>16,647</i> <i>14,483</i>	7002 6091	<i>15,422</i> <i>13,417</i>	6115 5320	<i>13,470</i> <i>11,719</i>	4093 3561	<i>9,016</i> <i>7,844</i>
1.5 m (5'0")					10 730 9335	<i>23,634</i> <i>20,562</i>	8567 7453	<i>18,870</i> <i>16,417</i>	7127 6200	<i>15,698</i> <i>13,657</i>	4740 4124	<i>10,441</i> <i>9,084</i>
0 m (0'0")			18 803 16 359	<i>41,417</i> <i>36,033</i>	12 247 10 654	<i>26,975</i> <i>23,468</i>	9179 7985	<i>20,217</i> <i>17,589</i>	7305 6355	<i>16,090</i> <i>13,998</i>	4939 4297	<i>10,878</i> <i>9,464</i>
-1.5 m (-5'0")			9850 8569	<i>21,695</i> <i>18,875</i>	12 595 10 957	<i>27,741</i> <i>24,135</i>	9205 8008	<i>20,275</i> <i>17,639</i>	7026 6112	<i>15,475</i> <i>13,463</i>		
-3.0 m (-10'0")	3712 3230	<i>8,177</i> <i>7,114</i>	9507 8271	<i>20,940</i> <i>18,218</i>	11 367 9889	<i>25,037</i> <i>21,782</i>	8250 7178	<i>18,172</i> <i>15,810</i>	5897 5131	<i>12,990</i> <i>11,301</i>		

# Millyards Stationary Mount Knuckleboom Loaders

## Lift and Range Diagram ● 569 SM Knuckleboom Loader ● 569 SM/EHC Knuckleboom Loader

### 569 SM/569 SM/EHC 10.9 m (36'0") Boom

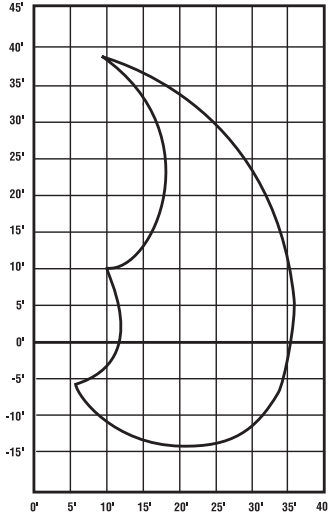

#### NOTES:

Do not attempt to lift or hold any load that is greater than the rated values over the end or side at their specified lift point and height. The weight of the grapple and all lifting accessories must be deducted from lift capacities shown.

1. All figures shown in these charts represent rated lift capacities.
2. Capacities shown in *italic* are 100% of hydraulic capacity; other capacities shown are 87% of hydraulic capability.
3. The lift point is located at the boom/grapple pivot pin.
4. Manufacturer assumes no responsibility for the proper fit or structural integrity of the mounting pedestal and/or platform supplied by the customer.
5. Operator should be fully acquainted with the Operator's Manual and all safety instructions furnished prior to operating the machine.
6. Lift capacities are in compliance with SAE J2417, "Lift Capacity Calculation Method – Knuckleboom Log Loaders and Certain Forestry Equipment."

	3 m/10'0"		4.6 m/15'0"		6.1 m/20'0"		7.6 m/25'0"		9.1 m/30'0"		10.6 m/35'0"	
	kg	lb	kg	lb	kg	lb	kg	lb	kg	lb	kg	lb
10.6 m (35'0")			<i>5110</i> 4446	<i>11,255</i> 9,792								
9.1 m (30'0")					4985 4337	<i>10,979</i> <i>9,552</i>						
7.6 m (25'0")					5744 4998	<i>12,653</i> <i>11,008</i>	4697 4086	<i>10,345</i> <i>9,000</i>				
6.1 m (20'0")					6087 5295	<i>13,407</i> <i>11,664</i>	5508 4792	<i>12,132</i> <i>10,555</i>	3943 3430	<i>8,685</i> <i>7,556</i>		
4.6 m (15'0")					6629 5767	<i>14,601</i> <i>12,703</i>	5997 5218	<i>13,210</i> <i>11,493</i>	5037 4382	<i>11,094</i> <i>9,652</i>		
3.0 m (10'0")			8808 7663	<i>19,400</i> <i>16,878</i>	7924 6894	<i>17,454</i> <i>15,185</i>	6701 5830	<i>14,761</i> <i>12,842</i>	5444 4737	<i>11,992</i> <i>10,433</i>	2748 2391	<i>6,053</i> <i>5,266</i>
1.5 m (5'0")			11 401 9919	<i>25,113</i> <i>21,848</i>	8652 7527	<i>19,057</i> <i>16,580</i>	7024 6111	<i>15,472</i> <i>13,461</i>	5873 5109	<i>12,936</i> <i>11,254</i>	3306 2877	<i>7,283</i> <i>6,336</i>
0 m (0'0")			12 364 10 757	<i>27,233</i> <i>23,693</i>	9096 7914	<i>20,036</i> <i>17,431</i>	7171 6239	<i>15,795</i> <i>13,742</i>	5804 5049	<i>12,784</i> <i>11,122</i>	3200 2784	<i>7,048</i> <i>6,132</i>
-1.5 m (-5'0")	4876 4242	<i>10,740</i> <i>9,344</i>	12 156 10 575	<i>26,775</i> <i>23,294</i>	8973 7806	<i>19,763</i> <i>17,194</i>	6956 6051	<i>15,321</i> <i>13,329</i>	5420 4716	<i>11,939</i> <i>10,387</i>		
-3.0 m (-10'0")	5803 5049	<i>12,783</i> <i>11,121</i>	10 713 9321	<i>23,598</i> <i>20,530</i>	8081 7030	<i>17,799</i> <i>15,485</i>	6170 5368	<i>13,591</i> <i>11,824</i>	4454 3875	<i>9,810</i> <i>8,535</i>		

**Wheel Loader Forestry Features:**

**988K** — Logging Arrangement equips the 988K with larger lift and tilt cylinders, additional counterweight, and 3V hydraulics. Heavy-duty tires (42PR or \*\*) are required for the strength and durability required in millyard applications. Work tool attachments, such as logging forks are designed for heavy-duty applications; loading and unloading trucks, sorting, decking and feeding the mill.

**990H** — The 990H Millyard Arrangement equips the machine with larger lift and tilt cylinders, extra counterweight, and 3V hydraulics for top clamp control. The larger machine is recommended for millyards which may have uneven terrain where more stability is required.

**980M/980K/980H** — Forest Machine Arrangement equips the 980M, 980K, and 980H with an extreme service transmission, heavy-duty tilt cylinders and additional counterweight for the strength and durability required to be productive in this tough application. Logging, millyard and wood pallet forks, woodchip and clean-up buckets can be added to equip the machines for forestry applications.

**966M/966K/966H** — Forest Machine Arrangements on the 966M, 966K, and 966H provide ride control, heavy-duty tilt cylinders and an additional counterweights for use in forestry and logging applications. Specially designed work tools for forestry applications can be factory-installed.

**950M/962M/950K/962K/950H** — Forest Machine Arrangements on the 950M, 962M, 950K, 962K and 950H provide ride control, heavy-duty tilt cylinders and an additional counterweights for use in forestry and logging applications. Specially designed work tools for forestry applications can be factory-installed.

<b>MODEL</b>	<b>988K</b>	
Operating Weight	61 241 kg	<b>135,014 lb</b>
Engine Model	<b>C18 ACERT</b>	
Full Turn Static Tipping Load (Logging Forks)	31 079 kg	<b>68,517 lb</b>
	<b>@ 37 degree articulation</b>	

**926M\* with Fusion Coupler — Cat 1829 mm (72") Log and Lumber Fork**

Tine Length	1829 mm	72.0"
Load Center	914 mm	36.0"
Static Tipping Load — Straight (Forks Level)	5991 kg	13,204 lb
Static Tipping Load — Articulated (Forks Level)	5134 kg	11,315 lb
Rated Load (SAE J1197 — 50% FTSTL)	2567 kg	5658 lb
Rated Load (CEN EN 474-3 Rough Terrain — 60% FTSTL)	3080 kg	6789 lb
Rated Load (CEN EN 474-3 Firm and Level Ground — 80% FTSTL)	4107 kg	9052 lb
Reach with Arms Horizontal and Forks Level	1590 mm	62.6"
Reach with Fork at Maximum Height	788 mm	31.0"
Ground to Top of Tine with Arms Horizontal and Fork Level	1755 mm	69.1"
Ground to Top of Tine at Maximum Height and Fork Level	3656 mm	143.9"
Operating Weight	13 615 kg	30,007 lb

\*Meets Tier 4 Final/Stage IV/Japan 2014 (Tier 4 Final) emission standards.

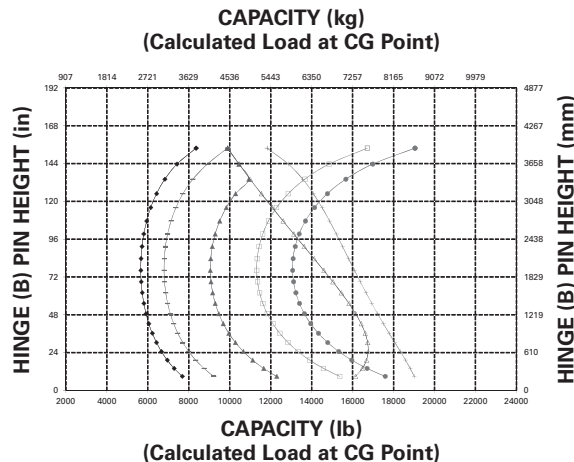

**KEY**

- ◆ Payload (SAE J1197)
- Payload (CEN EN 474-3 Rough Terrain)
- ▲ Payload (CEN EN 474-3 Firm and Level)
- ◻ Static Tipping Load — Articulated
- Static Tipping Load — Straight
- △ Hydraulic Tilt Capacity (Level Tool)
- + Hydraulic Lift Capacity (Level Tool)

Curves based on machine with Michelin 20.5R25 XHA2 tires, logger counterweight, additional guarding, 80 kg (176 lb) operator, full fuel tank, and 399-0708 log and lumber fork with 1829 mm (72") tines.

**930M\* with Fusion Coupler — Cat 1829 mm (72") Log and Lumber Fork**

Tine Length	1829 mm	72.0"
Load Center	914 mm	36.0"
Static Tipping Load — Straight (Forks Level)	6822 kg	15,036 lb
Static Tipping Load — Articulated (Forks Level)	5827 kg	12,843 lb
Rated Load (SAE J1197 — 50% FTSTL)	2914 kg	6421 lb
Rated Load (CEN EN 474-3 Rough Terrain — 60% FTSTL)	3496 kg	7706 lb
Rated Load (CEN EN 474-3 Firm and Level Ground — 80% FTSTL)	4662 kg	10,274 lb
Reach with Arms Horizontal and Forks Level	1590 mm	62.6"
Reach with Fork at Maximum Height	788 mm	31.0"
Ground to Top of Tine with Arms Horizontal and Fork Level	1755 mm	69.1"
Ground to Top of Tine at Maximum Height and Fork Level	3656 mm	143.9"
Operating Weight	14 527 kg	32,018 lb

\*Meets Tier 4 Final/Stage IV/Japan 2014 (Tier 4 Final) emission standards.

5

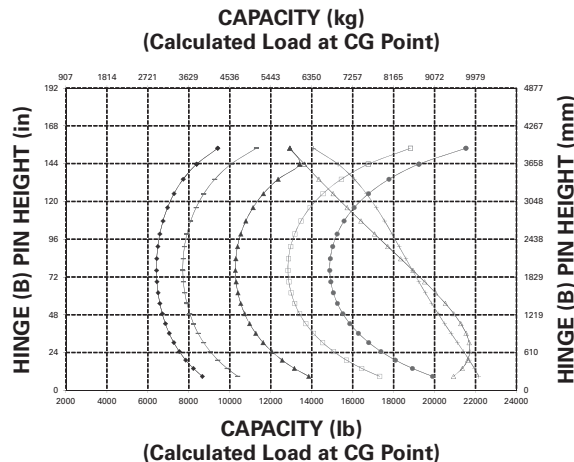

**KEY**

- ◆ Payload (SAE J1197)
- Payload (CEN EN 474-3 Rough Terrain)
- ▲ Payload (CEN EN 474-3 Firm and Level)
- ◻ Static Tipping Load — Articulated
- Static Tipping Load — Straight
- △ Hydraulic Tilt Capacity (Level Tool)
- + Hydraulic Lift Capacity (Level Tool)

Curves based on machine with Michelin 20.5R25 XHA2 tires, logger counterweight, additional guarding, 80 kg (176 lb) operator, full fuel tank, and 399-0708 log and lumber fork with 1829 mm (72") tines.



**938M\* with Fusion Coupler — Cat 1829 mm (72") Log and Lumber Fork**

Tine Length	1829 mm	72.0"
Load Center	914 mm	36.0"
Static Tipping Load — Straight (Forks Level)	8207 kg	18,088 lb
Static Tipping Load — Articulated (Forks Level)	7005 kg	15,439 lb
Rated Load (SAE J1197 — 50% FTSTL)	3503 kg	7720 lb
Rated Load (CEN EN 474-3 Rough Terrain — 60% FTSTL)	4203 kg	9263 lb
Rated Load (CEN EN 474-3 Firm and Level Ground — 80% FTSTL)	5604 kg	12,351 lb
Reach with Arms Horizontal and Forks Level	1638 mm	64.5"
Reach with Fork at Maximum Height	835 mm	32.9"
Ground to Top of Tine with Arms Horizontal and Fork Level	1791 mm	70.5"
Ground to Top of Tine at Maximum Height and Fork Level	3718 mm	146.4"
Operating Weight	16 739 kg	36,893 lb

\*Meets Tier 4 Final/Stage IV/Japan 2014 (Tier 4 Final) emission standards.

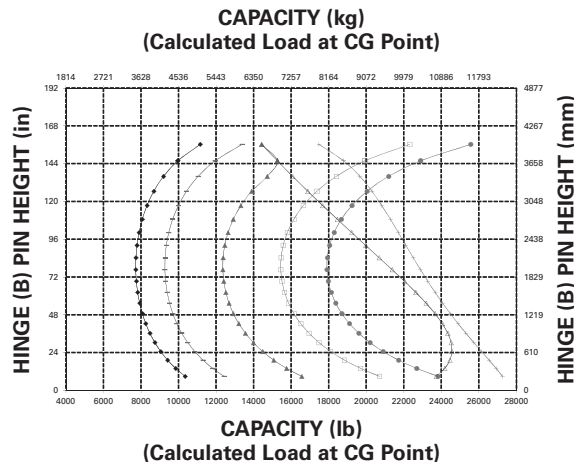

**KEY**

- ◆ Payload (SAE J1197)
- Payload (CEN EN 474-3 Rough Terrain)
- ▲ Payload (CEN EN 474-3 Firm and Level)
- ◻ Static Tipping Load — Articulated
- Static Tipping Load — Straight
- △ Hydraulic Tilt Capacity (Level Tool)
- + Hydraulic Lift Capacity (Level Tool)

Curves based on machine with Michelin 20.5R25 XHA2 tires, logger counterweight, additional guarding, 80 kg (176 lb) operator, full fuel tank, and 399-0708 log and lumber fork with 1829 mm (72") tines.

**924K with Fusion Coupler — Cat 1829 mm (72") Log and Lumber Fork**

Tine Length	1829 mm	72.0"
Load Center	914 mm	36.0"
Static Tipping Load — Straight (Forks Level)	5993 kg	13,209 lb
Static Tipping Load — Articulated (Forks Level)	5132 kg	11,311 lb
Rated Load (SAE J1197 — 50% FTSTL)	2566 kg	5655 lb
Rated Load (CEN EN 474-3 Rough Terrain — 60% FTSTL)	3079 kg	6787 lb
Rated Load (CEN EN 474-3 Firm and Level Ground — 80% FTSTL)	4106 kg	9049 lb
Reach with Arms Horizontal and Forks Level	1543 mm	60.7"
Reach with Fork at Maximum Height	745 mm	29.3"
Ground to Top of Tine with Arms Horizontal and Fork Level	1725 mm	67.9"
Ground to Top of Tine at Maximum Height and Fork Level	3602 mm	141.8"
Operating Weight	13 151 kg	28,985 lb

5

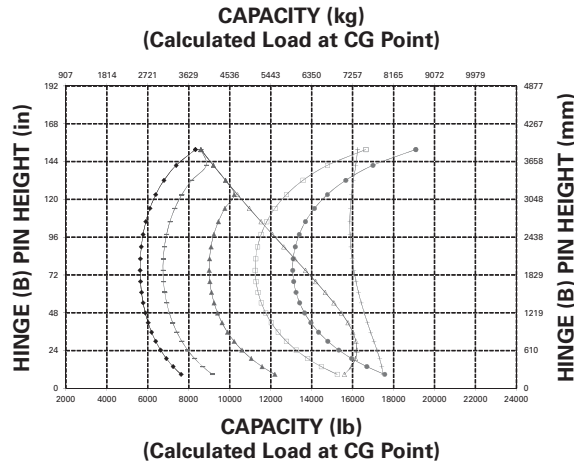

**KEY**

- ◆ Payload (SAE J1197)
- Payload (CEN EN 474-3 Rough Terrain)
- ▲ Payload (CEN EN 474-3 Firm and Level)
- ◻ Static Tipping Load — Articulated
- Static Tipping Load — Straight
- △ Hydraulic Tilt Capacity (Level Tool)
- + Hydraulic Lift Capacity (Level Tool)

Curves based on machine with Michelin 20.5R25 XHA2 tires, logger counterweight, additional guarding, 80 kg (176 lb) operator, full fuel tank, and 399-0708 log and lumber fork with 1829 mm (72") tines.

**930K with Fusion Coupler — Cat 1829 mm (72") Log and Lumber Fork**

Tine Length	1829 mm	72.0"
Load Center	914 mm	36.0"
Static Tipping Load — Straight (Forks Level)	6644 kg	14,643 lb
Static Tipping Load — Articulated (Forks Level)	5683 kg	12,525 lb
Rated Load (SAE J1197 — 50% FTSTL)	2842 kg	6263 lb
Rated Load (CEN EN 474-3 Rough Terrain — 60% FTSTL)	3410 kg	7515 lb
Rated Load (CEN EN 474-3 Firm and Level Ground — 80% FTSTL)	4546 kg	10,020 lb
Reach with Arms Horizontal and Forks Level	1590 mm	62.6"
Reach with Fork at Maximum Height	788 mm	31.0"
Ground to Top of Tine with Arms Horizontal and Fork Level	1755 mm	69.1"
Ground to Top of Tine at Maximum Height and Fork Level	3656 mm	143.9"
Operating Weight	14 263 kg	31,436 lb

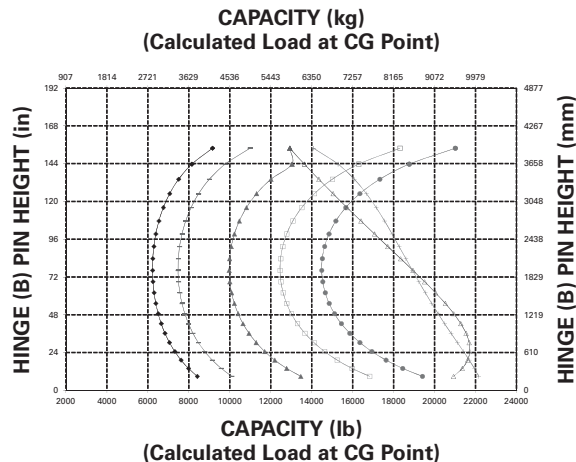

**KEY**

- ◆ Payload (SAE J1197)
- Payload (CEN EN 474-3 Rough Terrain)
- ▲ Payload (CEN EN 474-3 Firm and Level)
- ◻ Static Tipping Load — Articulated
- Static Tipping Load — Straight
- △ Hydraulic Tilt Capacity (Level Tool)
- + Hydraulic Lift Capacity (Level Tool)

Curves based on machine with Michelin 20.5R25 XHA2 tires, logger counterweight, additional guarding, 80 kg (176 lb) operator, full fuel tank, and 399-0708 log and lumber fork with 1829 mm (72") tines.

**938K with Fusion Coupler — Cat 1829 mm (72") Log and Lumber Fork**

Tine Length	1829 mm	72.0"
Load Center	914 mm	36.0"
Static Tipping Load — Straight (Forks Level)	8018 kg	17,672 lb
Static Tipping Load — Articulated (Forks Level)	6851 kg	15,100 lb
Rated Load (SAE J1197 — 50% FTSTL)	3426 kg	7550 lb
Rated Load (CEN EN 474-3 Rough Terrain — 60% FTSTL)	4111 kg	9060 lb
Rated Load (CEN EN 474-3 Firm and Level Ground — 80% FTSTL)	5481 kg	12,080 lb
Reach with Arms Horizontal and Forks Level	1638 mm	64.5"
Reach with Fork at Maximum Height	835 mm	32.9"
Ground to Top of Tine with Arms Horizontal and Fork Level	1791 mm	70.5"
Ground to Top of Tine at Maximum Height and Fork Level	3718 mm	146.4"
Operating Weight	16 458 kg	36,273 lb

5

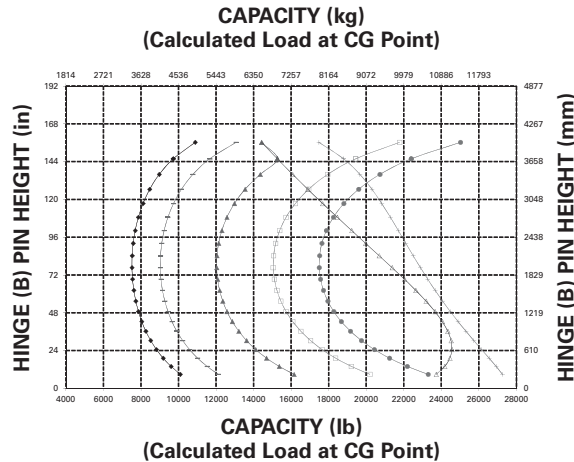

**KEY**

- ◆ Payload (SAE J1197)
- Payload (CEN EN 474-3 Rough Terrain)
- ▲ Payload (CEN EN 474-3 Firm and Level)
- ◻ Static Tipping Load — Articulated
- Static Tipping Load — Straight
- △ Hydraulic Tilt Capacity (Level Tool)
- + Hydraulic Lift Capacity (Level Tool)

Curves based on machine with Michelin 20.5R25 XHA2 tires, logger counterweight, additional guarding, 80 kg (176 lb) operator, full fuel tank, and 399-0708 log and lumber fork with 1829 mm (72") tines.

**926M\* with Fusion Coupler — Cat 2438 mm (96") Log and Lumber Fork**

Tine Length	2438 mm	96.0"
Load Center	1219 mm	48.0"
Static Tipping Load — Straight (Forks Level)	5358 kg	11,809 lb
Static Tipping Load — Articulated (Forks Level)	4578 kg	10,090 lb
Rated Load (SAE J1197 — 50% FTSTL)	2289 kg	5045 lb
Rated Load (CEN EN 474-3 Rough Terrain — 60% FTSTL)	2747 kg	6054 lb
Rated Load (CEN EN 474-3 Firm and Level Ground — 80% FTSTL)	3662 kg	8072 lb
Reach with Arms Horizontal and Forks Level	1590 mm	62.6"
Reach with Fork at Maximum Height	788 mm	31.0"
Ground to Top of Tine with Arms Horizontal and Fork Level	1755 mm	69.1"
Ground to Top of Tine at Maximum Height and Fork Level	3656 mm	143.9"
Operating Weight	13 710 kg	30,217 lb

\*Meets Tier 4 Final/Stage IV/Japan 2014 (Tier 4 Final) emission standards.

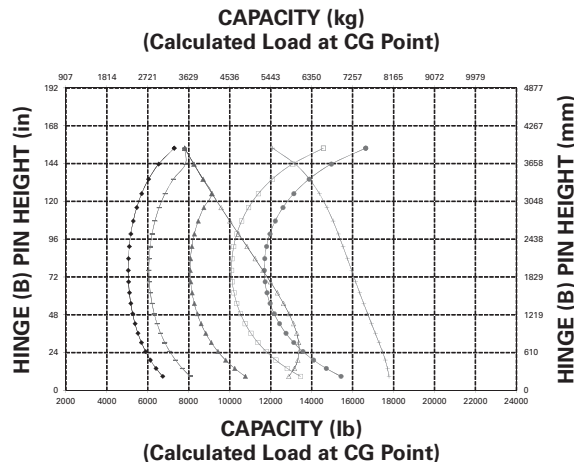

**KEY**

- ◆ Payload (SAE J1197)
- Payload (CEN EN 474-3 Rough Terrain)
- ▲ Payload (CEN EN 474-3 Firm and Level)
- ◻ Static Tipping Load — Articulated
- Static Tipping Load — Straight
- △ Hydraulic Tilt Capacity (Level Tool)
- + Hydraulic Lift Capacity (Level Tool)

Curves based on machine with Michelin 20.5R25 XHA2 tires, logger counterweight, additional guarding, 80 kg (176 lb) operator, full fuel tank, and 464-8153 log and lumber fork with 2438 mm (96") tines.

**930M\* with Fusion Coupler — Cat 2438 mm (96") Log and Lumber Fork**

Tine Length	2438 mm	96.0"
Load Center	1219 mm	48.0"
Static Tipping Load — Straight (Forks Level)	6115 kg	13,477 lb
Static Tipping Load — Articulated (Forks Level)	5209 kg	11,481 lb
Rated Load (SAE J1197 — 50% FTSTL)	2605 kg	5740 lb
Rated Load (CEN EN 474-3 Rough Terrain — 60% FTSTL)	3125 kg	6888 lb
Rated Load (CEN EN 474-3 Firm and Level Ground — 80% FTSTL)	4167 kg	9185 lb
Reach with Arms Horizontal and Forks Level	1590 mm	62.6"
Reach with Fork at Maximum Height	788 mm	31.0"
Ground to Top of Tine with Arms Horizontal and Fork Level	1755 mm	69.1"
Ground to Top of Tine at Maximum Height and Fork Level	3656 mm	143.9"
Operating Weight	14 622 kg	32,227 lb

\*Meets Tier 4 Final/Stage IV/Japan 2014 (Tier 4 Final) emission standards.

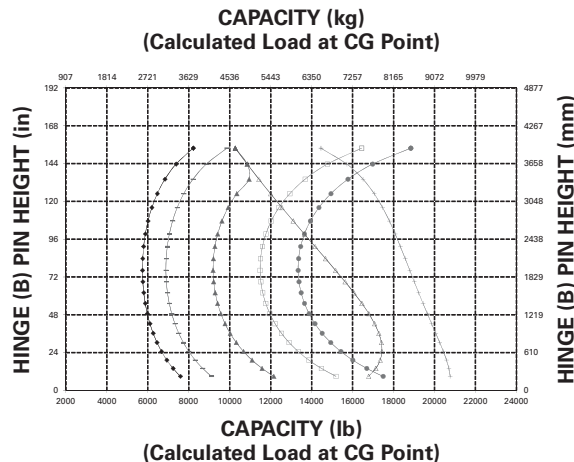

**KEY**

- ◆ Payload (SAE J1197)
- Payload (CEN EN 474-3 Rough Terrain)
- ▲ Payload (CEN EN 474-3 Firm and Level)
- ◻ Static Tipping Load — Articulated
- Static Tipping Load — Straight
- △ Hydraulic Tilt Capacity (Level Tool)
- + Hydraulic Lift Capacity (Level Tool)

Curves based on machine with Michelin 20.5R25 XHA2 tires, logger counterweight, additional guarding, 80 kg (176 lb) operator, full fuel tank, and 464-8153 log and lumber fork with 2438 mm (96") tines.

**938M\* with Fusion Coupler — Cat 2438 mm (96") Log and Lumber Fork**

Tine Length	2438 mm	96.0"
Load Center	1219 mm	48.0"
Static Tipping Load — Straight (Forks Level)	7388 kg	16,283 lb
Static Tipping Load — Articulated (Forks Level)	6292 kg	13,868 lb
Rated Load (SAE J1197 — 50% FTSTL)	3146 kg	6934 lb
Rated Load (CEN EN 474-3 Rough Terrain — 60% FTSTL)	3775 kg	8321 lb
Rated Load (CEN EN 474-3 Firm and Level Ground — 80% FTSTL)	5034 kg	11,094 lb
Reach with Arms Horizontal and Forks Level	1638 mm	64.5"
Reach with Fork at Maximum Height	835 mm	32.9"
Ground to Top of Tine with Arms Horizontal and Fork Level	1791 mm	70.5"
Ground to Top of Tine at Maximum Height and Fork Level	3718 mm	146.4"
Operating Weight	16 834 kg	37,102 lb

\*Meets Tier 4 Final/Stage IV/Japan 2014 (Tier 4 Final) emission standards.

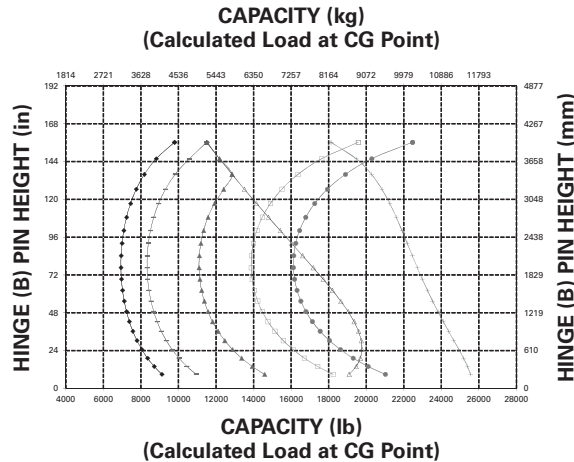

**KEY**

- ◆ Payload (SAE J1197)
- Payload (CEN EN 474-3 Rough Terrain)
- ▲ Payload (CEN EN 474-3 Firm and Level)
- ◻ Static Tipping Load — Articulated
- Static Tipping Load — Straight
- △ Hydraulic Tilt Capacity (Level Tool)
- + Hydraulic Lift Capacity (Level Tool)

Curves based on machine with Michelin 20.5R25 XHA2 tires, logger counterweight, additional guarding, 80 kg (176 lb) operator, full fuel tank, and 464-8153 log and lumber fork with 2438 mm (96") tines.

**926M\* with Fusion Coupler — Cat 1524 mm (60") Millyard Fork**

Tine Length	1524 mm	60.0"
Load Center	762 mm	30.0"
Static Tipping Load — Straight (Forks Level)	5645 kg	12,442 lb
Static Tipping Load — Articulated (Forks Level)	4740 kg	10,447 lb
Rated Load (SAE J1197 — 50% FTSTL)	2370 kg	5223 lb
Rated Load (CEN EN 474-3 Rough Terrain — 60% FTSTL)	2844 kg	6268 lb
Rated Load (CEN EN 474-3 Firm and Level Ground — 80% FTSTL)	3792 kg	8358 lb
Reach with Arms Horizontal and Forks Level	1667 mm	65.6"
Reach with Fork at Maximum Height	865 mm	34.1"
Ground to Top of Tine with Arms Horizontal and Fork Level	1747 mm	68.8"
Ground to Top of Tine at Maximum Height and Fork Level	3648 mm	143.6"
Operating Weight	14 533 kg	32,031 lb

\*Meets Tier 4 Final/Stage IV/Japan 2014 (Tier 4 Final) emission standards.

5

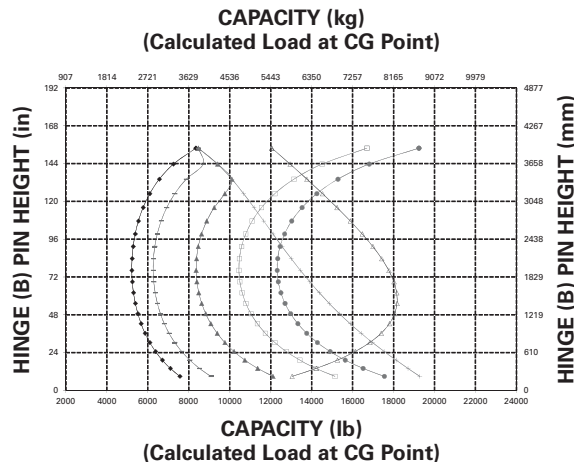

**KEY**

- ◆ Payload (SAE J1197)
- Payload (CEN EN 474-3 Rough Terrain)
- ▲ Payload (CEN EN 474-3 Firm and Level)
- ◻ Static Tipping Load — Articulated
- Static Tipping Load — Straight
- △ Hydraulic Tilt Capacity (Level Tool)
- + Hydraulic Lift Capacity (Level Tool)

Curves based on machine with Michelin 20.5R25 XHA2 tires, logger counterweight, additional guarding, 80 kg (176 lb) operator, full fuel tank, and 415-4023 millyard fork with 1524 mm (60") tines.



**930M\* with Fusion Coupler — Cat 1524 mm (60") Millyard Fork**

Tine Length	1524 mm	60.0"
Load Center	762 mm	30.0"
Static Tipping Load — Straight (Forks Level)	6531 kg	14,394 lb
Static Tipping Load — Articulated (Forks Level)	5479 kg	12,076 lb
Rated Load (SAE J1197 — 50% FTSTL)	2740 kg	6038 lb
Rated Load (CEN EN 474-3 Rough Terrain — 60% FTSTL)	3287 kg	7245 lb
Rated Load (CEN EN 474-3 Firm and Level Ground — 80% FTSTL)	4383 kg	9661 lb
Reach with Arms Horizontal and Forks Level	1667 mm	65.6"
Reach with Fork at Maximum Height	865 mm	34.1"
Ground to Top of Tine with Arms Horizontal and Fork Level	1747 mm	68.8"
Ground to Top of Tine at Maximum Height and Fork Level	3648 mm	143.6"
Operating Weight	15 445 kg	34,041 lb

\*Meets Tier 4 Final/Stage IV/Japan 2014 (Tier 4 Final) emission standards.

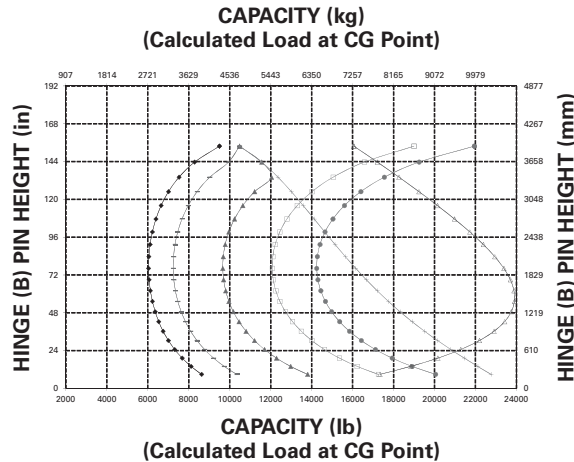

**KEY**

- ◆ Payload (SAE J1197)
- Payload (CEN EN 474-3 Rough Terrain)
- ▲ Payload (CEN EN 474-3 Firm and Level)
- ◻ Static Tipping Load — Articulated
- Static Tipping Load — Straight
- △ Hydraulic Tilt Capacity (Level Tool)
- + Hydraulic Lift Capacity (Level Tool)

Curves based on machine with Michelin 20.5R25 XHA2 tires, logger counterweight, additional guarding, 80 kg (176 lb) operator, full fuel tank, and 415-4023 millyard fork with 1524 mm (60") tines.

**938M\* with Fusion Coupler — Cat 1524 mm (60") Millyard Fork**

Tine Length	1524 mm	60.0"
Load Center	762 mm	30.0"
Static Tipping Load — Straight (Forks Level)	8000 kg	17,632 lb
Static Tipping Load — Articulated (Forks Level)	6728 kg	14,829 lb
Rated Load (SAE J1197 — 50% FTSTL)	3364 kg	7414 lb
Rated Load (CEN EN 474-3 Rough Terrain — 60% FTSTL)	4037 kg	8897 lb
Rated Load (CEN EN 474-3 Firm and Level Ground — 80% FTSTL)	5382 kg	11,863 lb
Reach with Arms Horizontal and Forks Level	1715 mm	67.5"
Reach with Fork at Maximum Height	912 mm	35.9"
Ground to Top of Tine with Arms Horizontal and Fork Level	1785 mm	70.3"
Ground to Top of Tine at Maximum Height and Fork Level	3713 mm	146.2"
Operating Weight	17 657 kg	38,916 lb

\*Meets Tier 4 Final/Stage IV/Japan 2014 (Tier 4 Final) emission standards.

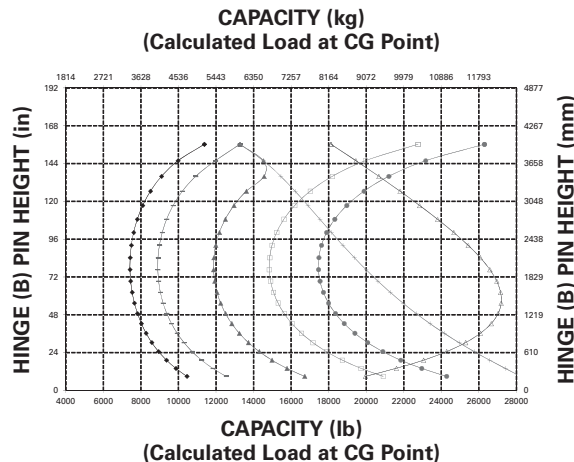

**KEY**

- ◆ Payload (SAE J1197)
- Payload (CEN EN 474-3 Rough Terrain)
- ▲ Payload (CEN EN 474-3 Firm and Level)
- ◻ Static Tipping Load — Articulated
- Static Tipping Load — Straight
- △ Hydraulic Tilt Capacity (Level Tool)
- + Hydraulic Lift Capacity (Level Tool)

Curves based on machine with Michelin 20.5R25 XHA2 tires, logger counterweight, additional guarding, 80 kg (176 lb) operator, full fuel tank, and 415-4023 millyard fork with 1524 mm (60") tines.

**930M\* with Fusion Coupler — Cat 1.9 m<sup>2</sup> (20.4 ft<sup>2</sup>) Sorting Grapple**

End Area	1.9 m <sup>2</sup>	20.4 ft <sup>2</sup>
Load Center	610 mm	24.0"
Static Tipping Load — Straight (Forks Level)	6526 kg	14,383 lb
Static Tipping Load — Articulated (Forks Level)	5488 kg	12,096 lb
Rated Load (SAE J1197 — 50% FTSTL)	2744 kg	6048 lb
Rated Load (CEN EN 474-3 Rough Terrain — 60% FTSTL)	3293 kg	7257 lb
Rated Load (CEN EN 474-3 Firm and Level Ground — 80% FTSTL)	4390 kg	9676 lb
Reach with Arms Horizontal and Forks Level	1561 mm	61.5"
Reach with Fork at Maximum Height	760 mm	29.9"
Ground to Top of Tine with Arms Horizontal and Fork Level	1684 mm	66.3"
Ground to Top of Tine at Maximum Height and Fork Level	3586 mm	141.2"
Operating Weight	15 132 kg	33,351 lb

\*Meets Tier 4 Final/Stage IV/Japan 2014 (Tier 4 Final) emission standards.

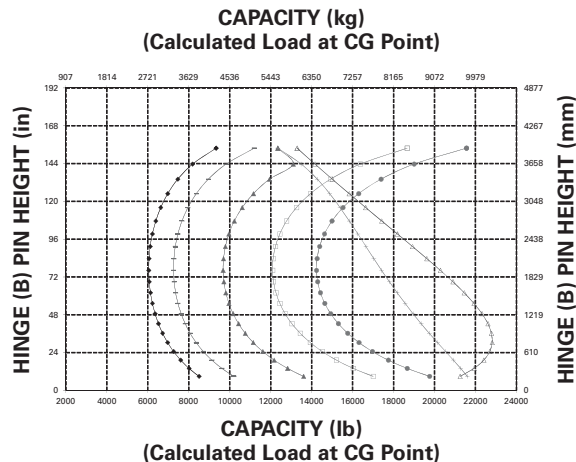

**KEY**

- ◆ Payload (SAE J1197)
- Payload (CEN EN 474-3 Rough Terrain)
- ▲ Payload (CEN EN 474-3 Firm and Level)
- ◻ Static Tipping Load — Articulated
- Static Tipping Load — Straight
- △ Hydraulic Tilt Capacity (Level Tool)
- + Hydraulic Lift Capacity (Level Tool)

Curves based on machine with Michelin 20.5R25 XHA2 tires, logger counterweight, additional guarding, 80 kg (176 lb) operator, full fuel tank, and 458-3462 1.9 m<sup>2</sup> (20.4 ft<sup>2</sup>) sorting grapple with 1219 mm (48") tines.

**938M\* with Fusion Coupler — Cat 1.9 m<sup>2</sup> (20.4 ft<sup>2</sup>) Sorting Grapple**

End Area	1.9 m <sup>2</sup>	20.4 ft <sup>2</sup>
Load Center	610 mm	24.0"
Static Tipping Load — Straight (Forks Level)	7978 kg	17,584 lb
Static Tipping Load — Articulated (Forks Level)	6722 kg	14,815 lb
Rated Load (SAE J1197 — 50% FTSTL)	3361 kg	7408 lb
Rated Load (CEN EN 474-3 Rough Terrain — 60% FTSTL)	4033 kg	8889 lb
Rated Load (CEN EN 474-3 Firm and Level Ground — 80% FTSTL)	5378 kg	11,852 lb
Reach with Arms Horizontal and Forks Level	1610 mm	63.4"
Reach with Fork at Maximum Height	807 mm	31.8"
Ground to Top of Tine with Arms Horizontal and Fork Level	1720 mm	67.7"
Ground to Top of Tine at Maximum Height and Fork Level	3648 mm	143.6"
Operating Weight	17 344 kg	38,226 lb

\*Meets Tier 4 Final/Stage IV/Japan 2014 (Tier 4 Final) emission standards.

5

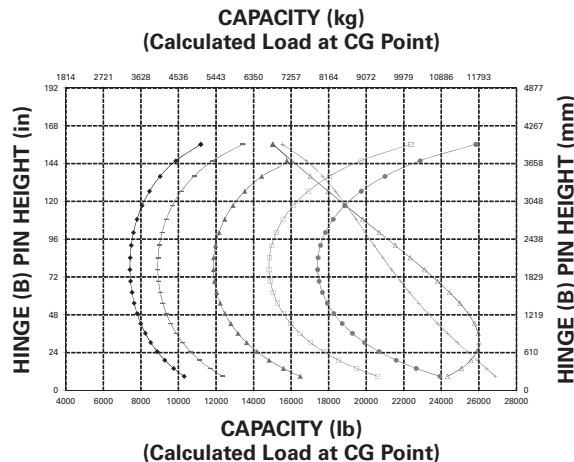

**KEY**

- ◆ Payload (SAE J1197)
- Payload (CEN EN 474-3 Rough Terrain)
- ▲ Payload (CEN EN 474-3 Firm and Level)
- ◻ Static Tipping Load — Articulated
- Static Tipping Load — Straight
- △ Hydraulic Tilt Capacity (Level Tool)
- + Hydraulic Lift Capacity (Level Tool)

Curves based on machine with Michelin 20.5R25 XHA2 tires, logger counterweight, additional guarding, 80 kg (176 lb) operator, full fuel tank, and 458-3462 1.9 m<sup>2</sup> (20.4 ft<sup>2</sup>) sorting grapple with 1219 mm (48") tines.

**950M LOG  
Millyard Fork, Pin-On**

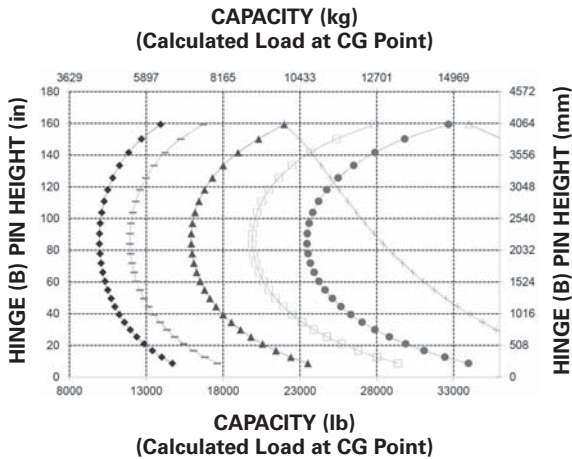

**950M LOG  
Millyard Pole Fork, Fusion**

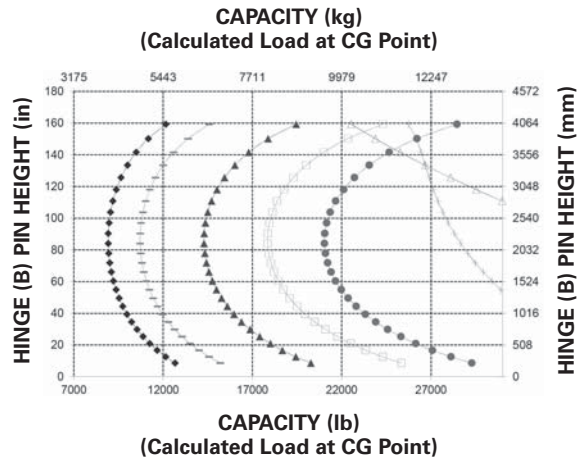

**KEY**

- ◆ Payload (SAE J1197)
- Payload (CEN EN 474-3 Rough Terrain)
- ▲ Payload (CEN EN 474-3 Firm and Level)
- ⊕ Static Tipping Load — Articulated
- Static Tipping Load — Straight
- △ Hydraulic Tilt Capacity
- ⊕ Hydraulic Lift Capacity

**NOTE:** Static tipping loads and operating weight are based on the following loader configuration: L3 Michelin XHA Tires, Air Conditioning, Ride Control, Power Train Guard, Full Fluids, Fuel Tank, Coolant, Lubricants, and Operator.

Specifications and ratings conform to the following standards: SAE\* J1197, SAE J732, CEN\*\* EN 474-3.

The rated operating load for a loader equipped with a pallet fork is determined by:

- SAE J1197: 50% of full turn static tipping load or hydraulic limit.
- CEN EN 474-3: 60% of full turn static tipping load on rough terrain or hydraulic limit.
- CEN EN 474-3: 80% of full turn static tipping load on firm and level ground or hydraulic limit.

\*SAE — Society of Automotive Engineers

\*\*CEN — European Committee for Standardization

950M LOG  
Grapple Fork, Pin-On

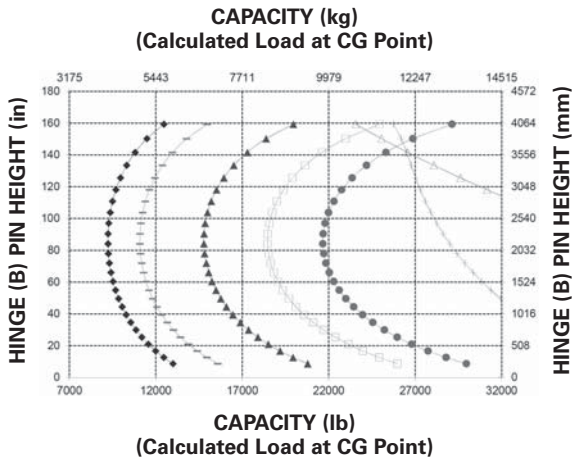

950M LOG  
UFO Grapple Fork, Fusion

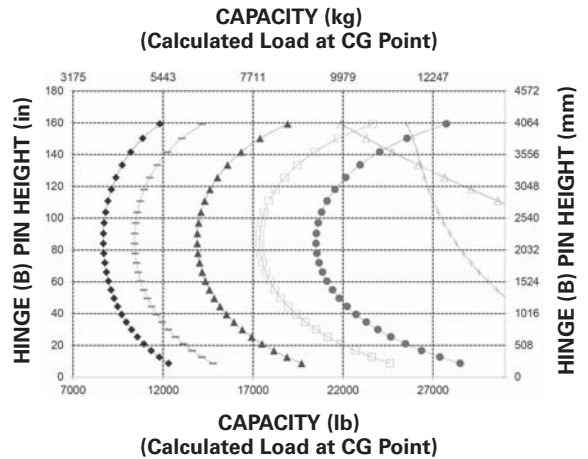

5

KEY

- ◆ Payload (SAE J1197)
- Payload (CEN EN 474-3 Rough Terrain)
- ▲ Payload (CEN EN 474-3 Firm and Level)
- ⊕ Static Tipping Load — Articulated
- Static Tipping Load — Straight
- △ Hydraulic Tilt Capacity
- ⊕ Hydraulic Lift Capacity

**NOTE:** Static tipping loads and operating weight are based on the following loader configuration: L3 Michelin XHA Tires, Air Conditioning, Ride Control, Power Train Guard, Full Fluids, Fuel Tank, Coolant, Lubricants, and Operator.

Specifications and ratings conform to the following standards: SAE\* J1197, SAE J732, CEN\*\* EN 474-3.

The rated operating load for a loader equipped with a pallet fork is determined by:

- SAE J1197: 50% of full turn static tipping load or hydraulic limit.
- CEN EN 474-3: 60% of full turn static tipping load on rough terrain or hydraulic limit.
- CEN EN 474-3: 80% of full turn static tipping load on firm and level ground or hydraulic limit.

\*SAE — Society of Automotive Engineers

\*\*CEN — European Committee for Standardization

- 950M
- 962M

**950M LOG**

**UFO Grapple Fork, Volvo Comp QC**

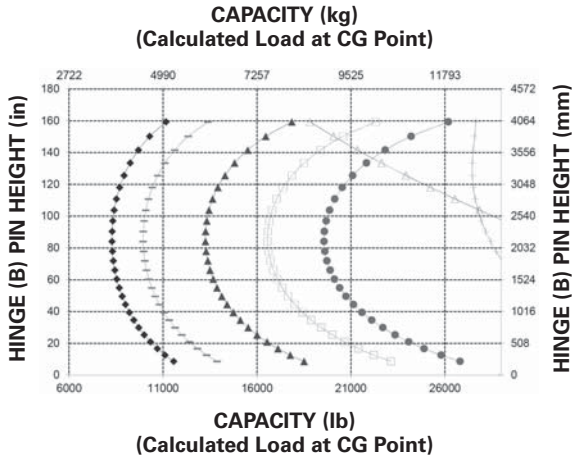

**962M LOG**

**Millyard Pole Fork, Fusion**

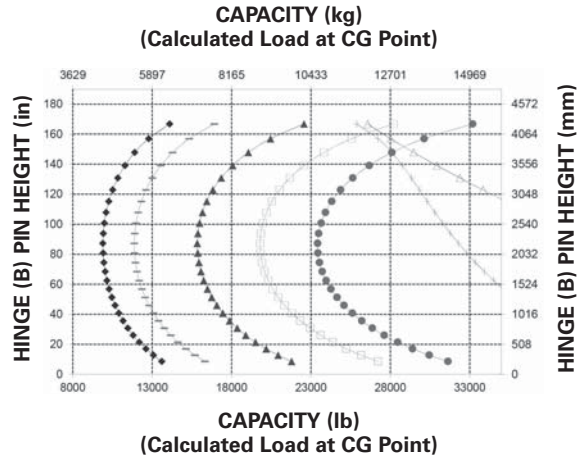

**KEY**

- ◆ Payload (SAE J1197)
- Payload (CEN EN 474-3 Rough Terrain)
- ▲ Payload (CEN EN 474-3 Firm and Level)
- ⊕ Static Tipping Load — Articulated
- Static Tipping Load — Straight
- △ Hydraulic Tilt Capacity
- ⊕ Hydraulic Lift Capacity

**NOTE:** Static tipping loads and operating weight are based on the following loader configuration: L3 Michelin XHA Tires, Air Conditioning, Ride Control, Power Train Guard, Full Fluids, Fuel Tank, Coolant, Lubricants, and Operator.

Specifications and ratings conform to the following standards: SAE\* J1197, SAE J732, CEN\*\* EN 474-3.

The rated operating load for a loader equipped with a pallet fork is determined by:

- SAE J1197: 50% of full turn static tipping load or hydraulic limit.
- CEN EN 474-3: 60% of full turn static tipping load on rough terrain or hydraulic limit.
- CEN EN 474-3: 80% of full turn static tipping load on firm and level ground or hydraulic limit.

\*SAE — Society of Automotive Engineers

\*\*CEN — European Committee for Standardization

962M LOG  
UFO Grapple Fork, Fusion

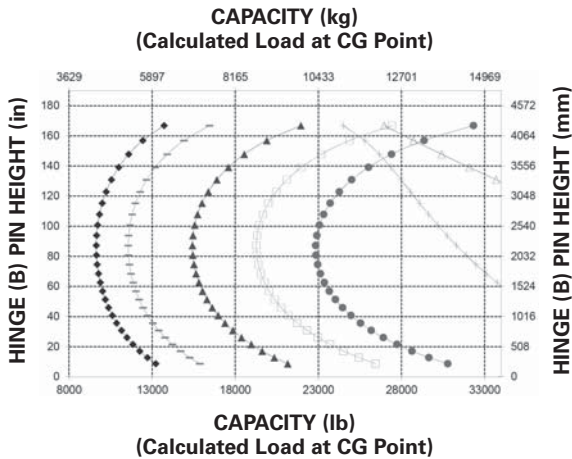

962M LOG  
UFO Grapple Fork, Volvo Comp QC

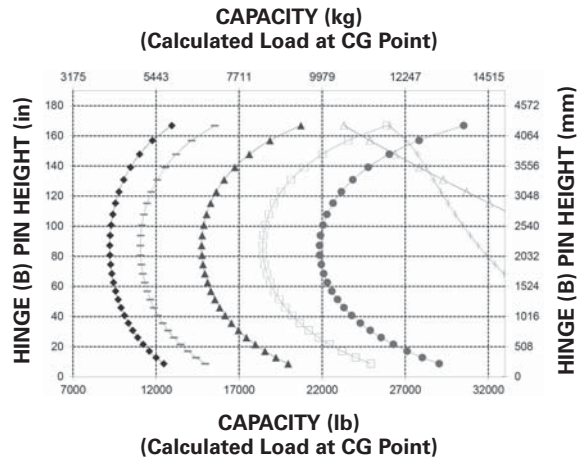

5

KEY

- ◆ Payload (SAE J1197)
- Payload (CEN EN 474-3 Rough Terrain)
- ▲ Payload (CEN EN 474-3 Firm and Level)
- ⊕ Static Tipping Load — Articulated
- Static Tipping Load — Straight
- △ Hydraulic Tilt Capacity
- + Hydraulic Lift Capacity

**NOTE:** Static tipping loads and operating weight are based on the following loader configuration: L3 Michelin XHA Tires, Air Conditioning, Ride Control, Power Train Guard, Full Fluids, Fuel Tank, Coolant, Lubricants, and Operator.

Specifications and ratings conform to the following standards: SAE\* J1197, SAE J732, CEN\*\* EN 474-3.

The rated operating load for a loader equipped with a pallet fork is determined by:

- SAE J1197: 50% of full turn static tipping load or hydraulic limit.
- CEN EN 474-3: 60% of full turn static tipping load on rough terrain or hydraulic limit.
- CEN EN 474-3: 80% of full turn static tipping load on firm and level ground or hydraulic limit.

\*SAE — Society of Automotive Engineers

\*\*CEN — European Committee for Standardization



**966M LOG**  
Millyard Fork, Fusion

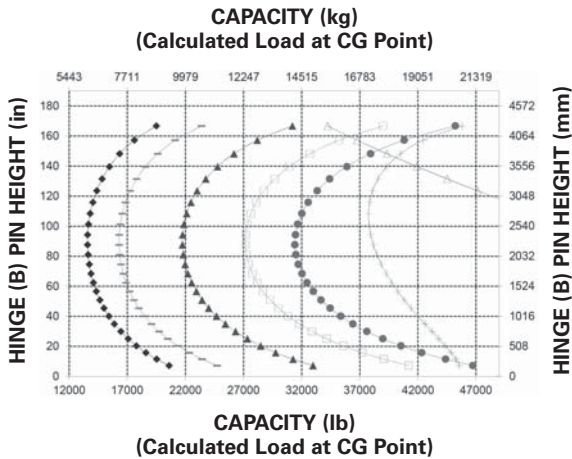

**966M LOG**  
Millyard Pole Fork, Pin-On

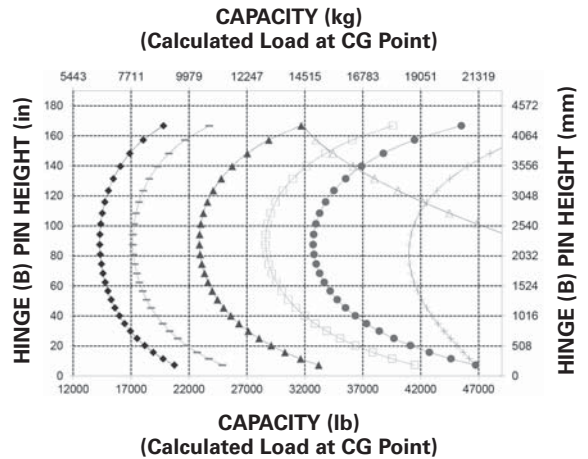

**KEY**

- ◆ Payload (SAE J1197)
- Payload (CEN EN 474-3 Rough Terrain)
- ▲ Payload (CEN EN 474-3 Firm and Level)
- ⊕ Static Tipping Load — Articulated
- Static Tipping Load — Straight
- △ Hydraulic Tilt Capacity
- ⊕ Hydraulic Lift Capacity

**NOTE:** Static tipping loads and operating weight are based on the following loader configuration: L3 Michelin XHA Tires, Air Conditioning, Ride Control, Power Train Guard, Full Fluids, Fuel Tank, Coolant, Lubricants, and Operator.

Specifications and ratings conform to the following standards: SAE\* J1197, SAE J732, CEN\*\* EN 474-3.

The rated operating load for a loader equipped with a pallet fork is determined by:

- SAE J1197: 50% of full turn static tipping load or hydraulic limit.
- CEN EN 474-3: 60% of full turn static tipping load on rough terrain or hydraulic limit.
- CEN EN 474-3: 80% of full turn static tipping load on firm and level ground or hydraulic limit.

\*SAE — Society of Automotive Engineers

\*\*CEN — European Committee for Standardization

**966M LOG**  
**Grapple Fork, Pin-On**

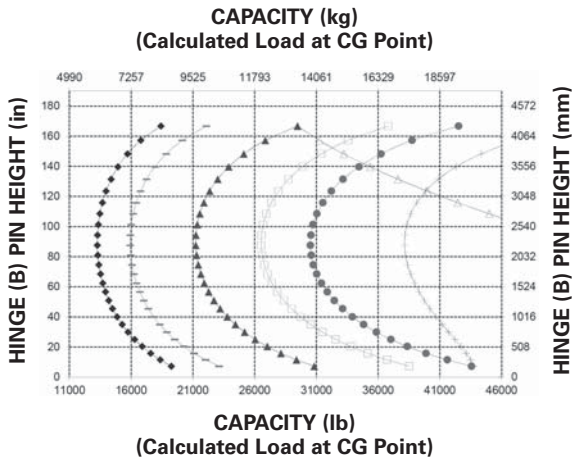

**980M LOG**  
**Millyard, Pin-On**

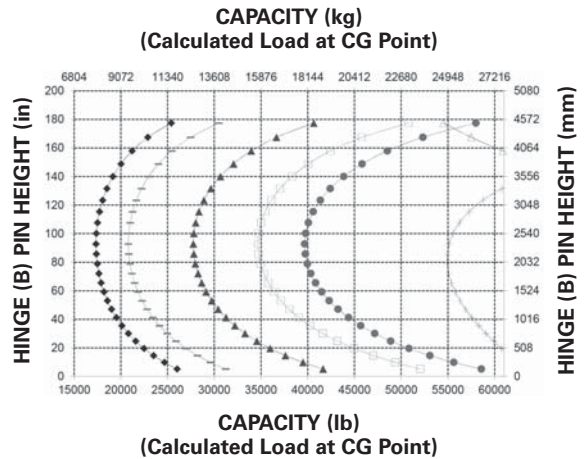

5

**KEY**

- ◆ Payload (SAE J1197)
- Payload (CEN EN 474-3 Rough Terrain)
- ▲ Payload (CEN EN 474-3 Firm and Level)
- ⊞ Static Tipping Load — Articulated
- Static Tipping Load — Straight
- △ Hydraulic Tilt Capacity
- ⊕ Hydraulic Lift Capacity

**NOTE:** Static tipping loads and operating weight are based on the following loader configuration: L3 Michelin XHATires, Air Conditioning, Ride Control, Power Train Guard, Full Fluids, Fuel Tank, Coolant, Lubricants, and Operator.

Specifications and ratings conform to the following standards: SAE\* J1197, SAE J732, CEN\*\* EN 474-3.

The rated operating load for a loader equipped with a pallet fork is determined by:

- SAE J1197: 50% of full turn static tipping load or hydraulic limit.
- CEN EN 474-3: 60% of full turn static tipping load on rough terrain or hydraulic limit.
- CEN EN 474-3: 80% of full turn static tipping load on firm and level ground or hydraulic limit.

\*SAE — Society of Automotive Engineers

\*\*CEN — European Committee for Standardization

- 966K
- 950H

**966K LOG  
Logging Fork, Pin-On**

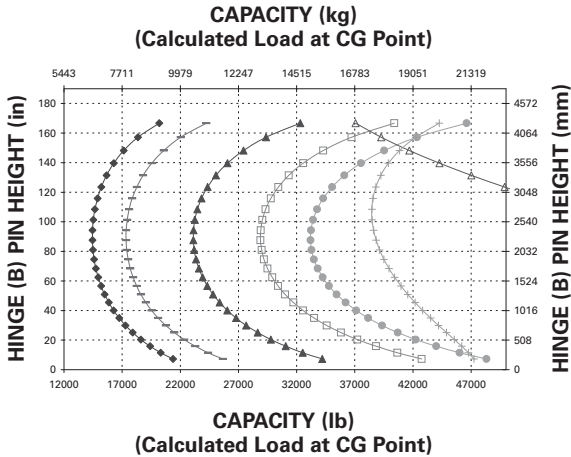

**950H LOG  
Millyard Fork, Pin-On**

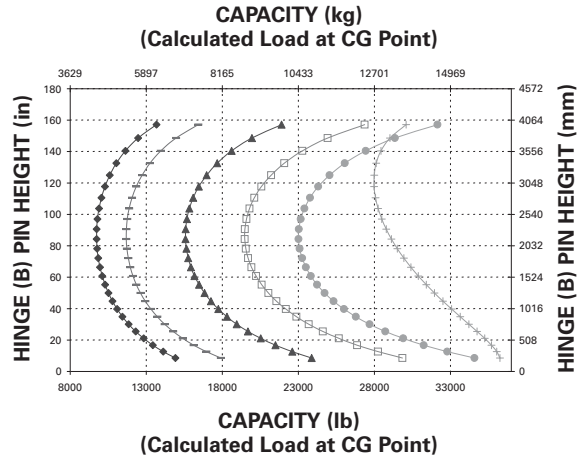

**KEY**

- ◆ Payload (SAE J1197)
- Payload (CEN EN 474-3 Rough Terrain)
- ▲ Payload (CEN EN 474-3 Firm and Level)
- Static Tipping Load – Articulated
- Static Tipping Load – Straight
- △ Hydraulic Tilt Capacity
- + Hydraulic Lift Capacity

**NOTE:** Static tipping loads and operating weight are based on the following loader configuration: L3 Michelin XHATires, Air Conditioning, Ride Control, Power Train Guard, Full Fluids, Fuel Tank, Coolant, Lubricants, and Operator.

Specifications and ratings conform to the following standards: SAE\* J1197, SAE J732, CEN\*\* EN 474-3.

The rated operating load for a loader equipped with a pallet fork is determined by:

- SAE J1197: 50% of full turn static tipping load or hydraulic limit.
- CEN EN 474-3: 60% of full turn static tipping load on rough terrain or hydraulic limit.
- CEN EN 474-3: 80% of full turn static tipping load on firm and level ground or hydraulic limit.

\*SAE – Society of Automotive Engineers

\*\*CEN – European Committee for Standardization

The 966K and 950H are not available in all regions. Contact your local Cat dealer for product availability.

966H LOG  
Millyard Fork, Pin-On

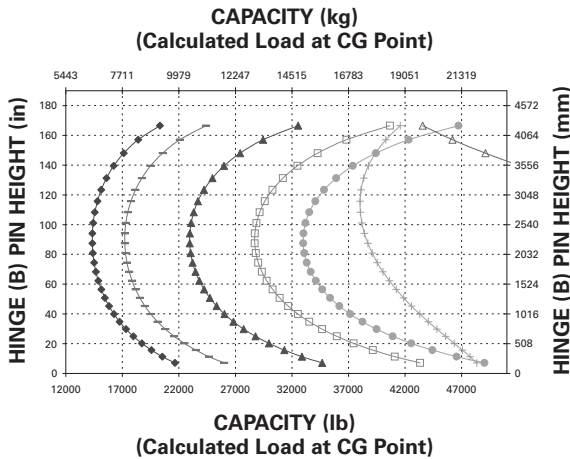

966H LOG  
Grapple Fork, Pin-On

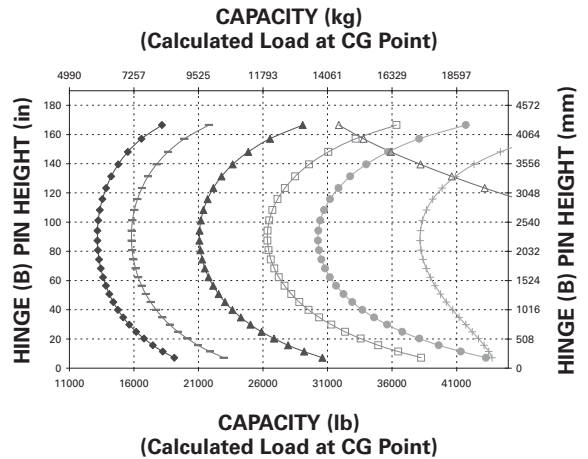

KEY

- ◆ Payload (SAE J1197)
- Payload (CEN EN 474-3 Rough Terrain)
- ▲ Payload (CEN EN 474-3 Firm and Level)
- Static Tipping Load – Articulated
- Static Tipping Load – Straight
- △ Hydraulic Tilt Capacity
- + Hydraulic Lift Capacity

**NOTE:** Static tipping loads and operating weight are based on the following loader configuration: L3 Michelin XHA Tires, Air Conditioning, Ride Control, Power Train Guard, Full Fluids, Fuel Tank, Coolant, Lubricants, and Operator.

Specifications and ratings conform to the following standards: SAE\* J1197, SAE J732, CEN\*\* EN 474-3.

The rated operating load for a loader equipped with a pallet fork is determined by:

- SAE J1197: 50% of full turn static tipping load or hydraulic limit.
- CEN EN 474-3: 60% of full turn static tipping load on rough terrain or hydraulic limit.
- CEN EN 474-3: 80% of full turn static tipping load on firm and level ground or hydraulic limit.

\*SAE — Society of Automotive Engineers

\*\*CEN — European Committee for Standardization

The 966H is not available in all regions. Contact your local Cat dealer for product availability.

**980H LOG  
Millyard Fork, Pin-On**

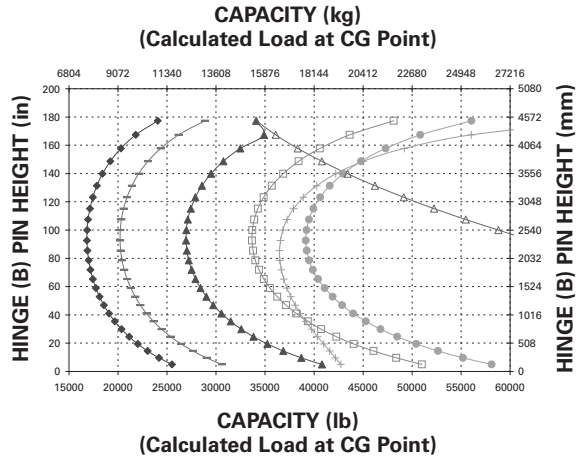

**KEY**

- ◆ Payload (SAE J1197)
- Payload (CEN EN 474-3 Rough Terrain)
- ▲ Payload (CEN EN 474-3 Firm and Level)
- ◻ Static Tipping Load – Articulated
- Static Tipping Load – Straight
- △ Hydraulic Tilt Capacity
- + Hydraulic Lift Capacity

**NOTE:** Static tipping loads and operating weight are based on the following loader configuration: L3 Michelin XHA Tires, Air Conditioning, Ride Control, Power Train Guard, Full Fluids, Fuel Tank, Coolant, Lubricants, and Operator.

Specifications and ratings conform to the following standards: SAE\* J1197, SAE J732, CEN\*\* EN 474-3.

The rated operating load for a loader equipped with a pallet fork is determined by:

- SAE J1197: 50% of full turn static tipping load or hydraulic limit.
- CEN EN 474-3: 60% of full turn static tipping load on rough terrain or hydraulic limit.
- CEN EN 474-3: 80% of full turn static tipping load on firm and level ground or hydraulic limit.

\*SAE — Society of Automotive Engineers

\*\*CEN — European Committee for Standardization

The 980H is not available in all regions. Contact your local Cat dealer for product availability.

**988K with Pin-On  
Cat Logging Fork**

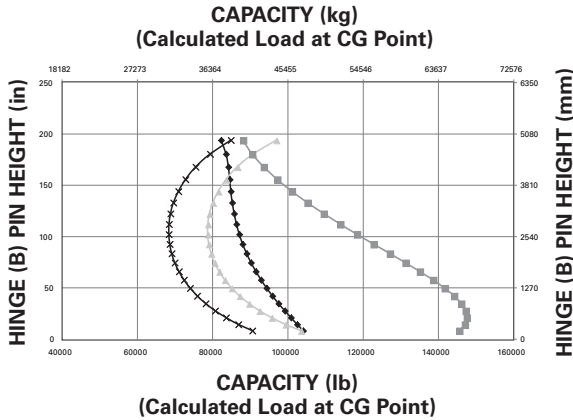

**990H with Pin-On  
Cat Logging Fork**

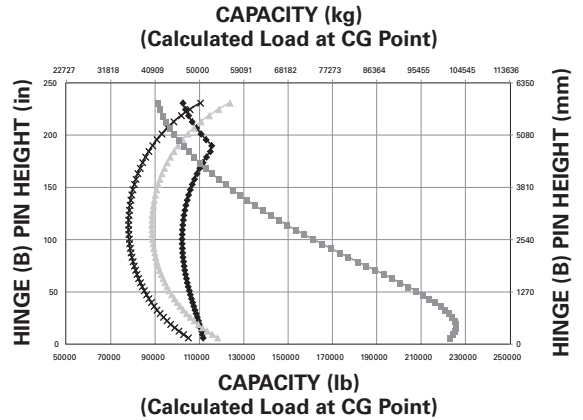

5

**KEY**

- ◆ Lift Capacity — Level Fork (988K)
- ▲ Straight Tipping — Level Fork (988K)
- ✕ 37° Tipping — Level Fork (988K)
- Tilt Capacity — Level Fork (988K)

Curves based on machine with full fuel tank, operator, ROPS cab, 35/65R33 \*\* (L-4) tires. Extra counterweight as supplied with Millyard Arrangement and 431-6176 double top clamp log fork. Total operating weight 63 600 kg (139,920 lb).

**KEY**

- ◆ Lift Capacity
- ✕ Articulated Tipping
- ▲ Straight Tipping
- Tilt Capacity

Curves based on machine with full fuel tank, operator, ROPS cab, 45/65R39 tires. Extra counterweight as supplied by Millyard Arrangement. 315-0458 millyard forks. Total operating weight 89 963 kg (197,919 lb).

**NOTE:** Static tipping load and operating weight are based on machine configuration with standard tires, full fuel tank, coolant, lubricants, and operator.

Specifications and ratings conform to all applicable standards recommended by the Society of Automotive Engineers (SAE). SAE Standards J732 JUN92 and J742 FEB85 govern loader ratings.

The rated operating load for a machine with fork is: SAE J1197; 50% of full turn static tipping load, or hydraulic/structural limit. CEN 474-3: 60% of full turn tipping load on rough terrain; 80% of full turn tipping load on firm and level ground, or hydraulic structural limit.

**586C Site Prep Tractor Features:**

- The C Series has been designed for **maximum performance and increased model versatility** to meet multi-customer applications.
- Durable Cat C9 and C9.3 Engines with ACERT Technology meet the demanding power requirements of site prep tractor applications while meeting Tier 4 Interim/Stage IIIB/Japan 2011 (Tier 4 Interim) or Tier 3/Stage IIIA/Japan 2006 (Tier 3) equivalent emission standards.
- The **high capacity cooling system**, with a hydraulic on-demand reversing fan, is designed to operate in high ambient air temperatures and extremely high debris applications while improving component life.
- The **load sense hydraulic systems** provide power on demand and multi-functioning capabilities to all functions of the machine while minimizing fuel consumption. **Cold weather system protections** have been designed into the system to maximize component durability.
- **PowerDirect Plus** optimizes the machine's performance, including the **high performance attachment hydraulic system**, by monitoring operator and attachment demand and delivering power where and when it is needed.
- A **robust drivetrain** includes a proven hydrostatic drive system, robust Cat axles, and **propel creep control** with on the fly adjustability to infinitely adjust ground speed for the application.
- **Heavy duty structures** utilize stream line box section design features, field proven dual taper roller bearing hitch design, integrated steering cylinder mounts, parent plate steering cylinder mounts and oversized chrome plated pins to provide increased life.
- The **transverse mounted engine** provides superior machine stability and ride quality while providing superior engine service, ground level fuel fill, hinged service panels, and pressurized engine/hydraulic and Cat emissions module compartments minimizing potential debris accumulation.
- **Serviceability** has been improved by the transverse mounted engine and other standard features like an electric hydraulic oil fill pump, tilting cab, strategic bulk heads and routings to improve hose and wire harness life and serviceability, and machine fault codes displayed as a text message on the machine monitor to minimize downtime for daily checks, preventative maintenance, and emergency service.
- The **refined operator's station** is positioned between the axles to provide excellent ride quality along with the standard air suspension seat, high capacity HVAC system, and ergonomic controls to reduce operator fatigue. The **attachment float control** option also reduces operator fatigue and improves performance.

<b>MODEL</b>	<b>586C HRC</b>		<b>586C LRC</b>	
Gross Power (ISO 14396)	261 kW	<b>350 hp</b>	261 kW	<b>350 hp</b>
Engine Model	<b>C9.3 ACERT</b>		<b>C9 ACERT</b>	
Engine Speed	<b>1880 RPM</b>		<b>1880 RPM</b>	
Travel Speed:				
Low Range with 30.5L-32 Tires	0-8.4 km/h	<b>0-5.2 mph</b>	0-8.4 km/h	<b>0-5.2 mph</b>
High Range with 30.5L-32 Tires	0-20.0 km/h	<b>0-12.4 mph</b>	0-20.0 km/h	<b>0-12.4 mph</b>
Hydrostatic Drive Pump (variable displacement piston pump)	242 L/min @ 37 370 kPa	<b>64 gpm @ 5420 psi</b>	242 L/min @ 37 370 kPa	<b>64 gpm @ 5420 psi</b>
Primary Hydraulic Pump (variable displacement piston pump)	155 L/min @ 27 579 kPa	<b>41 gpm @ 4000 psi</b>	155 L/min @ 27 579 kPa	<b>41 gpm @ 4000 psi</b>
Attachment Pump (variable displacement piston pump)	378 L/min @ 37 921 kPa	<b>100 gpm @ 5500 psi</b>	378 L/min @ 37 921 kPa	<b>100 gpm @ 5500 psi</b>
Fuel Capacity	494 L	<b>130.5 U.S. gal</b>	494 L	<b>130.5 U.S. gal</b>
Weight*	17 440 kg	<b>38,450 lb</b>	17 214 kg	<b>37,950 lb</b>

\*Weight includes Quick Coupler, Retrieval Assist Winch with Cable, and Full Fluids. Subtract 164 kg (362 lb) for 28L-26Tires and add 40 kg (88 lb) for 67-34Tires.



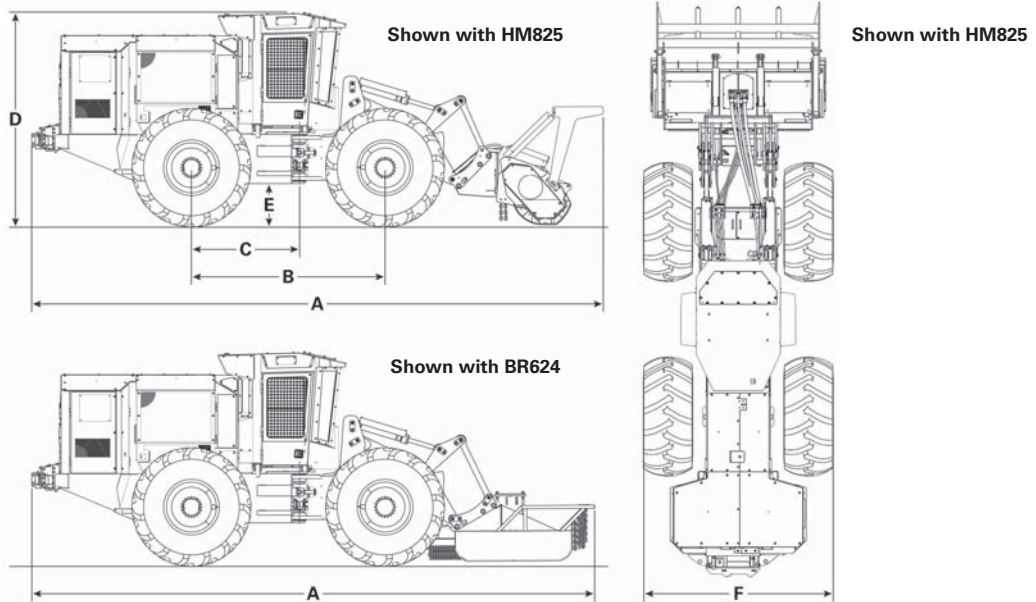

<b>MODEL</b>	<b>586C HRC</b>		<b>586C LRC</b>	
<b>A Overall Length*:</b>				
Length (with HM825)	9000 mm	<b>354.3"</b>	9000 mm	<b>354.3"</b>
Length (with BR624)	8855 mm	<b>348.6"</b>	8855 mm	<b>348.6"</b>
<b>B Wheelbase</b>	3048 mm	<b>120"</b>	3048 mm	<b>120"</b>
<b>C Rear Axle Center Line to Hitch Pin</b>	1702 mm	<b>67"</b>	1702 mm	<b>67"</b>
<b>D Overall Height**:</b>				
28L-26, NOAW	3223 mm	<b>126.9"</b>	3223 mm	<b>126.9"</b>
28L-26, STD	3223 mm	<b>126.9"</b>	3223 mm	<b>126.9"</b>
30.5L-32, NOAW	3324 mm	<b>130.9"</b>	3324 mm	<b>130.9"</b>
30.5L-32, STD	3324 mm	<b>130.9"</b>	3324 mm	<b>130.9"</b>
67-34, STD	3251 mm	<b>128.0"</b>	3251 mm	<b>128.0"</b>
<b>E Ground Clearance:</b>				
28L-26, NOAW	527.2 mm	<b>20.8"</b>	527.2 mm	<b>20.8"</b>
28L-26, STD	527.2 mm	<b>20.8"</b>	527.2 mm	<b>20.8"</b>
30.5L-32, NOAW	628.2 mm	<b>24.7"</b>	628.2 mm	<b>24.7"</b>
30.5L-32, STD	628.2 mm	<b>24.7"</b>	628.2 mm	<b>24.7"</b>
67-34, STD	555.2 mm	<b>21.9"</b>	555.2 mm	<b>21.9"</b>
<b>F Overall Width:</b>				
28L-26, NOAW	2793 mm	<b>110.0"</b>	2793 mm	<b>110.0"</b>
28L-26, STD	2920 mm	<b>115.0"</b>	2920 mm	<b>115.0"</b>
30.5L-32, NOAW	2980 mm	<b>117.3"</b>	2980 mm	<b>117.3"</b>
30.5L-32, STD	3140 mm	<b>123.6"</b>	3140 mm	<b>123.6"</b>
67-34, STD	3222 mm	<b>126.9"</b>	3222 mm	<b>126.9"</b>

\*Subtract 214 mm (8.4") for Tow Hooks in lieu of Retrieval Assist Winch.  
 \*\*Add 211 mm (8.3") for Road Ready Light Package.

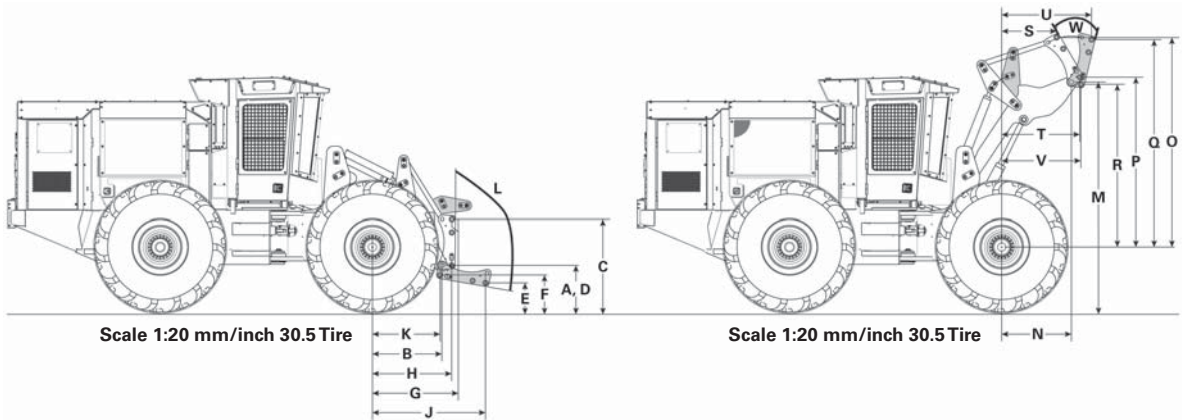

**Dimensions shown represent machine with 30.5L-32 Tires and Quick Coupler**

MODEL	586C HRC		586C LRC	
Lift Arm Lowered Position — Hinge Pin Location:				
<b>A</b> Hinge Pin Height*	591 mm	23.3"	591 mm	23.3"
<b>B</b> Hinge Pin Reach	997 mm	39.3"	997 mm	39.3"
Lift Arm Lowered Position — Quick Coupler Pin Locations:				
<b>C</b> Retracted Upper Pin Height*	1250 mm	49.2"	1250 mm	49.2"
<b>D</b> Retracted Lower Pin Height*	591 mm	23.3"	591 mm	23.3"
<b>E</b> Extended Upper Pin Height*	338 mm	13.3"	338 mm	13.3"
<b>F</b> Extended Lower Pin Height*	452 mm	17.8"	452 mm	17.8"
<b>G</b> Retracted Upper Pin Reach	1141 mm	44.9"	1141 mm	44.9"
<b>H</b> Retracted Lower Pin Reach	1121 mm	44.1"	1121 mm	44.1"
<b>J</b> Extended Upper Pin Reach	1624 mm	63.9"	1624 mm	63.9"
<b>K</b> Extended Lower Pin Reach	913 mm	35.9"	913 mm	35.9"
<b>L</b> Quick Coupler Range of Motion	99.6°		99.6°	
Lift Arm Raised Position — Hinge Pin Location:				
<b>M</b> Hinge Pin Height*	3217 mm	126.7"	3217 mm	126.7"
<b>N</b> Hinge Pin Reach	1001 mm	39.4"	1001 mm	39.4"
Lift Arm Raised Position — Quick Coupler Pin Locations:				
<b>O</b> Retracted Upper Pin Height*	3005 mm	118.3"	3005 mm	118.3"
<b>P</b> Retracted Lower Pin Height*	2435 mm	95.9"	2435 mm	95.9"
<b>Q</b> Extended Upper Pin Height*	2975 mm	117.1"	2975 mm	117.1"
<b>R</b> Extended Lower Pin Height*	2332 mm	91.8"	2332 mm	91.8"
<b>S</b> Retracted Upper Pin Reach	789 mm	31.0"	789 mm	31.0"
<b>T</b> Retracted Lower Pin Reach	1122 mm	44.2"	1122 mm	44.2"
<b>U</b> Extended Upper Pin Reach	1290 mm	50.7"	1290 mm	50.7"
<b>V</b> Extended Lower Pin Reach	1137 mm	44.8"	1137 mm	44.8"
<b>W</b> Quick Coupler Range of Motion	43.6°		43.6°	

\*Subtract 101 mm (4.0") for 28L-26Tires and 73 mm (2.9") for 67-34Tires.

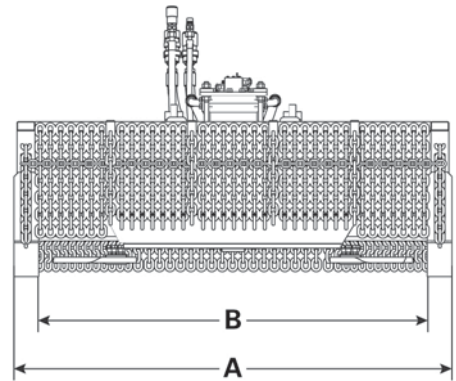
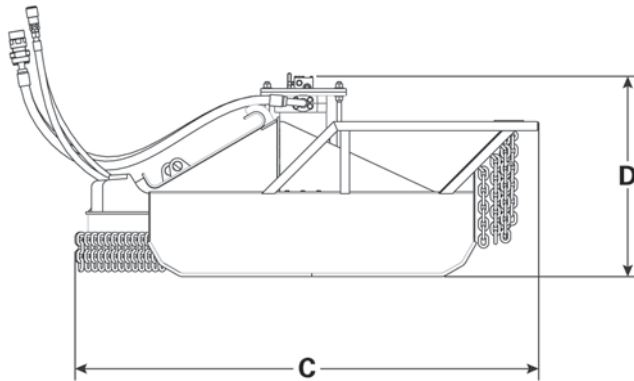

**MODEL**

**BR624**

<b>A</b> Overall Width	2474 mm	<b>97.4"</b>
<b>B</b> Working Width	2193 mm	<b>86.3"</b>
<b>C</b> Length	2618 mm	<b>103.1"</b>
<b>D</b> Height	873 mm	<b>44.4"</b>
Weight	2631 kg	<b>5800 lb</b>
Drive Method	<b>Direct Mount Rotor Bar</b>	
Hydraulic Motor Type	<b>Single Speed Axial Piston</b>	
Optimum Hydraulic Flow Range	246 L/min	<b>65 gpm</b>
Optimum Hydraulic Pressure Range	37 921 kPa	<b>5500 psi</b>
Optimum Speed	<b>950 RPM</b>	
Number of Blades	<b>2</b>	
Maximum Diameter of Material to be Cut	203 mm	<b>8"</b>

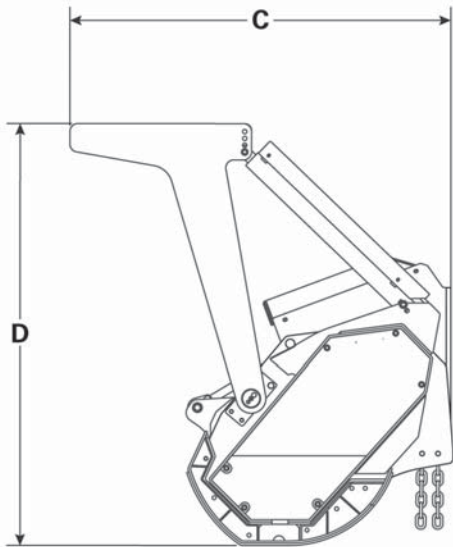
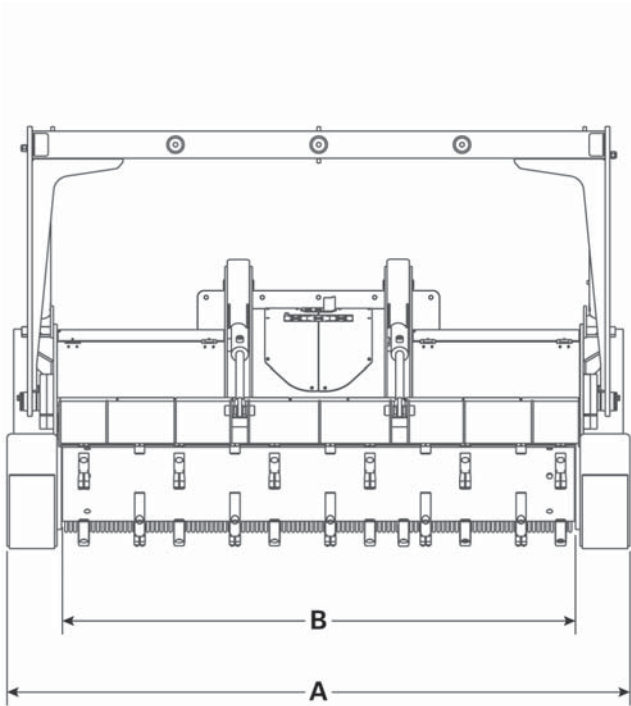

5

**MODEL**

**HM825**

<b>A</b> Overall Width	2900 mm	114.2"
<b>B</b> Working Width	2540 mm	100.0"
<b>C</b> Length	1677 mm	66.0"
<b>D</b> Height	1859 mm	73.2"
Weight	3697 kg	8150 lb
Drive Method	<b>Polychain Belt</b>	
Hydraulic Motor Type	<b>Dual Speed Axial Piston</b>	
Optimum Hydraulic Flow Range	378 L/min	100 gpm
Optimum Hydraulic Pressure Range	37 921 kPa	5500 psi
Optimum Drum Speed	<b>1200-1800 RPM</b>	
Number of Teeth	<b>58</b>	
Maximum Diameter of Material to be Cut	406 mm	16"



**WORK TOOLS**

Grapples for Heel Boom Log Loaders  
    Features ..... 5-127  
    Dimensions ..... 5-128

Logging Forks  
    Features ..... 5-129  
    Specifications ..... 5-129

Couplers  
    Features ..... 5-134

Buckets and Thumbs  
    Features ..... 5-134

Woodchip Dozers and Scoops  
    Features ..... 5-135  
    Specifications ..... 5-135

Rakes  
    Features ..... 5-136

**Features:**

- **Full 360° continuous rotation.**
- **Paddle style tines** are made of high strength steel, and use abrasion resistant material on tips for longer life.
- **Induction hardened** pins and bushings.
- **Heavy duty hydraulic cylinders** with built in check valves, and protective hose guarding for more uptime.

**Dimensions for Log Loading Grapples**

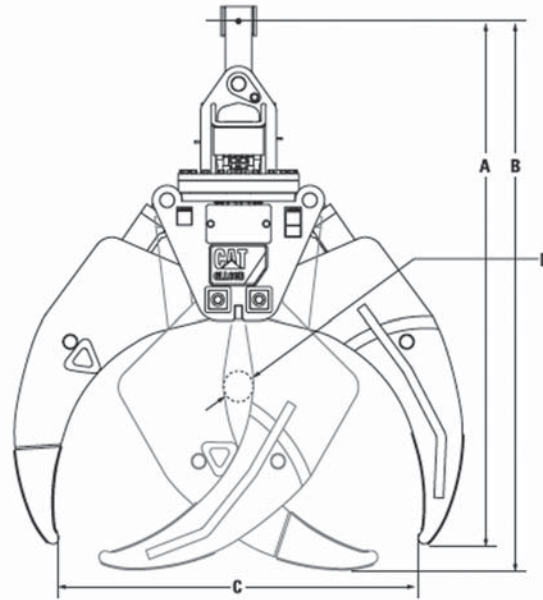

Part Number	GLL52B		GLL55B		GLL60B	
	271-1533		271-1534		271-1535	
Weight	1255 kg	<b>2767 lb</b>	1291 kg	<b>2840 lb</b>	1344 kg	<b>2965 lb</b>
Width	673 mm	<b>26.5"</b>	673 mm	<b>26.5"</b>	673 mm	<b>26.5"</b>
<b>A</b> Height, Open	2134 mm	<b>84"</b>	2184 mm	<b>86"</b>	2261 mm	<b>89"</b>
<b>B</b> Height, Closed	2159 mm	<b>85"</b>	2210 mm	<b>87"</b>	2286 mm	<b>90"</b>
<b>C</b> Maximum Opening	1321 mm	<b>52"</b>	1397 mm	<b>55"</b>	1524 mm	<b>60"</b>
<b>D</b> Minimum Opening	127 mm	<b>5"</b>	127 mm	<b>5"</b>	127 mm	<b>5"</b>
Rotation, Continuous	<b>360°</b>		<b>360°</b>		<b>360°</b>	
Rotation, Torque @ 8273 kPa ( <b>1200 psi</b> )	1153 N·m	<b>850 ft-lb</b>	1153 N·m	<b>850 lb-ft</b>	1153 N·m	<b>850 lb-ft</b>

**Features:**

**Loader Fork**

- Few work tool lines can match the range and utility of Cat Forks. Forks transform loaders into high performance material handling platforms capable of sorting, stacking and working wherever product, palletized material or lumber is at hand.

**Millyard and Logging Forks**

- Cat Millyard and double top clamp forks are performance-matched to Cat Wheel Loaders for unmatched on-the-job performance. The design features of fork and loader complement each other to make the ideal total system solution for log handling applications. Both forks are ideally suited for heavy-duty applications: loading and unloading trucks, sorting, decking, and feeding the mill.

**Log and Lumber Forks**

- Handle logs or finished lumber with equal ease. The top clamp holds loose loads securely, and the pallet-style forks make short palletized material. This versatility makes them suitable for a wide range of jobs including loading trucks, decking and sorting lumber or logs.

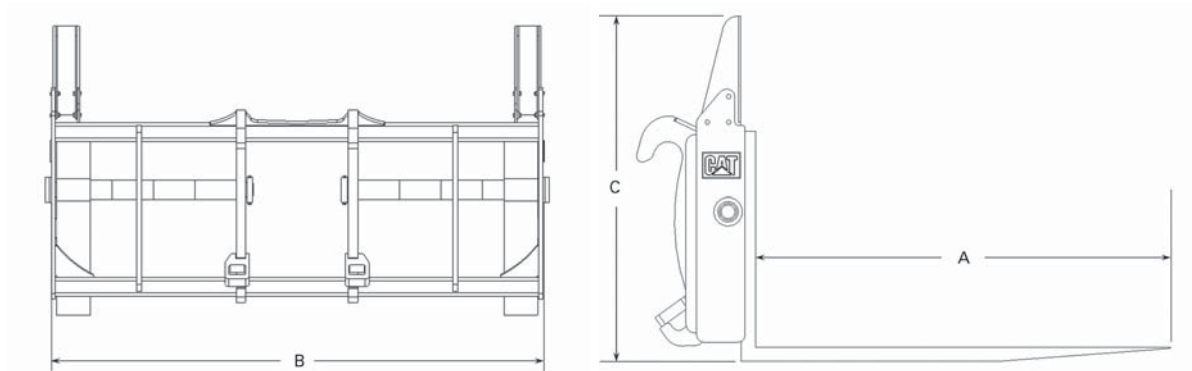

MODEL	924K/926M/930K/938M	
Model	Log & Lumber Fork	
Group Number	399-0708	
Logging Arrangement	399-0708	
Linkage Arrangement	(Fusion Coupler)	
A – Tine Length	1829 mm	6'0"
B – Overall Width	2591 mm	8'6"
C – Back Height	1526 mm	5'0"
Weight, Approximate	1181 kg	2604 lb



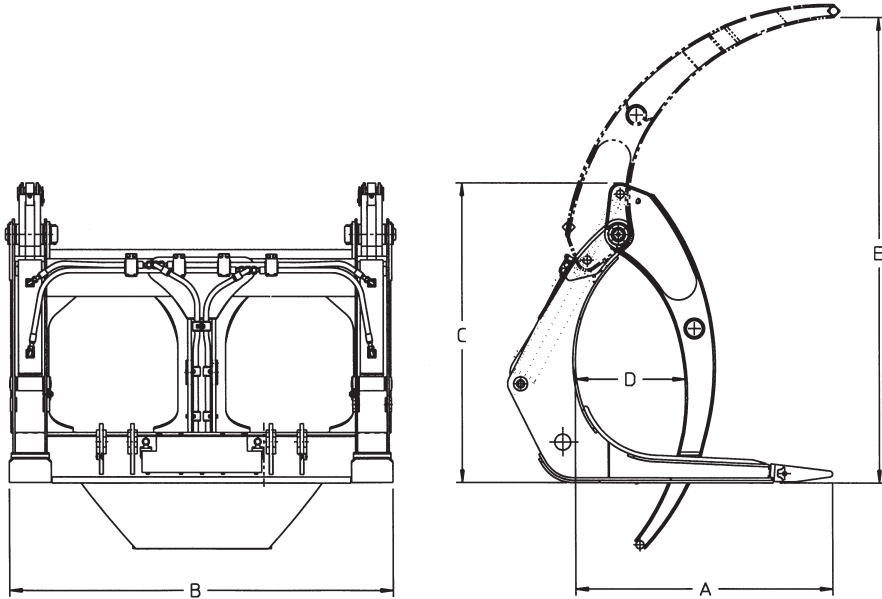

MODEL	924K/926M/930K/938M		950H/962H		950H/962H	
Model	Millyard Fork		Millyard Fork		Logging Fork	
Group Number	415-4023		256-7361		257-1959	
Logging Arrangement	(Fusion Coupler)		(Pin-On)		(Pin-On)	
Linkage Arrangement						
A – Tine Length	1524 mm	60"	1618 mm	5'4"	1626 mm	5'4"
B – Overall Width	2204 mm	7'3"	2724 mm	8'11"	2261 mm	7'5"
C – Back Height	1492 mm	4'11"	1919 mm	6'3"	1895 mm	6'2"
D – Minimum Opening	487 mm	19.2"	–	–	1535 mm	5'0"
E – Maximum Clamp Opening	2883 mm	9'6"	–	–	2520 mm	8'4"
Weight, Approximate	2099 kg	4628 lb	2515 kg	5545 lb	2200 kg	4860 lb

**NOTE:** Third valve required. Counterweight recommended.  
Logging forks with millyard style clamps are available where logging application requires clamp to close between tines.

The 950H and 962H are not available in all regions. Contact your local Cat dealer for product availability.

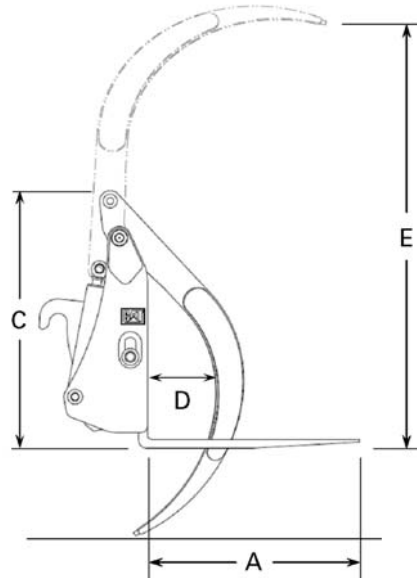
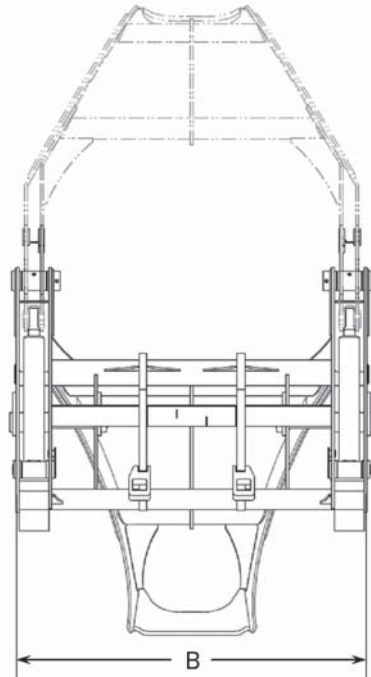

**MODEL 924K/926M/930K/938M**

<b>Model</b>	<b>Millyard Pole Fork</b>	
<b>Group Number</b>		
<b>Logging Arrangement</b>	<b>396-1370</b>	
<b>Linkage Arrangement</b>	<b>(Fusion Coupler)</b>	
<b>A – Tine Length</b>	1371 mm	<b>54"</b>
<b>B – Overall Width</b>	2264 mm	<b>7'5"</b>
<b>C – Back Height</b>	1629 mm	<b>5'4"</b>
<b>D – Minimum Opening</b>	166 mm	<b>6'5"</b>
<b>E – Maximum Clamp Opening</b>	2707 mm	<b>8'11"</b>
<b>Weight, Approximate</b>	1720 kg	<b>3790 lb</b>

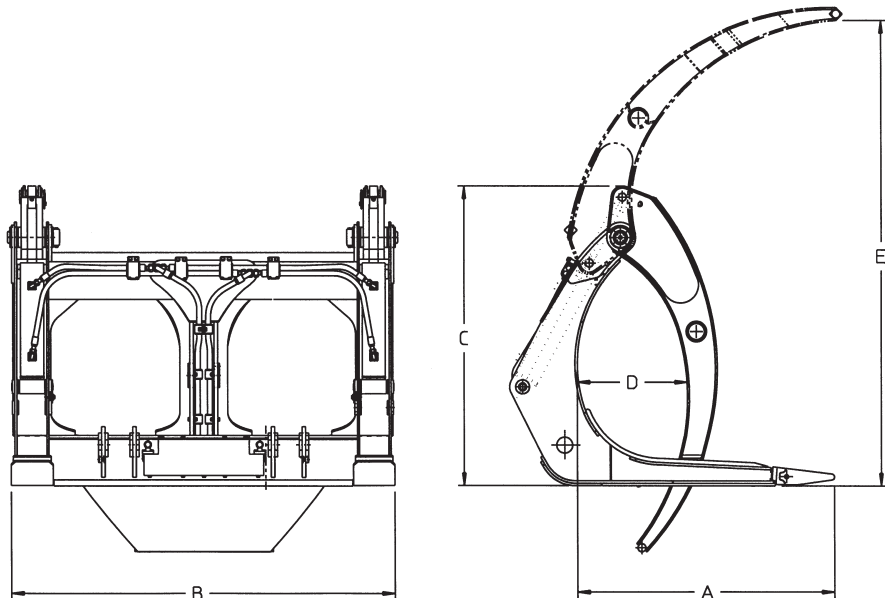

<b>MODEL</b>	<b>950H/962H</b>		<b>966H/972K/972M</b>		<b>966H</b>	
<b>Model</b>	<b>Logging Fork</b>		<b>Millyard</b>		<b>Logging</b>	
<b>Group Number</b>						
<b>Logging Arrangement</b>	<b>257-1960</b>		<b>253-7320</b>		<b>255-7333</b>	
<b>Linkage Arrangement</b>	<b>(Coupler)</b>		<b>—</b>		<b>—</b>	
<b>A — Tine Length</b>	1626 mm	<b>5'4"</b>	1618 mm	<b>5'4"</b>	1618 mm	<b>5'4"</b>
<b>B — Overall Width</b>	2261 mm	<b>7'5"</b>	2416 mm	<b>7'11"</b>	2416 mm	<b>7'11"</b>
<b>C — Back Height</b>	1895 mm	<b>6'2"</b>	1905 mm	<b>6'3"</b>	1897 mm	<b>6'3"</b>
<b>D — Minimum Opening</b>	1535 mm	<b>5'0"</b>	697 mm	<b>2'3"</b>	1603 mm	<b>5'3"</b>
<b>E — Maximum Clamp Opening</b>	2520 mm	<b>8'4"</b>	2927 mm	<b>9'7"</b>	2563 mm	<b>8'5"</b>
<b>Weight, Approximate</b>	2200 kg	<b>4860 lb</b>	2681 kg	<b>5911 lb</b>	2300 kg	<b>5065 lb</b>

<b>MODEL</b>	<b>966H</b>		<b>980H</b>		<b>980H</b>	
<b>Model</b>	<b>Log and Lumber W/TC</b>		<b>Double Top Clamp</b>		<b>Millyard Fork</b>	
<b>Group Number</b>						
<b>Logging Arrangement</b>	<b>143-7209</b>		<b>190-3982</b>		<b>192-7656</b>	
<b>A — Tine Length</b>	1524 mm	<b>5'0"</b>	1829 mm	<b>6'0"</b>	1830 mm	<b>6'0"</b>
<b>B — Overall Width</b>	2502 mm	<b>8'3"</b>	2756 mm	<b>9'2"</b>	2880 mm	<b>9'5"</b>
<b>C — Back Height</b>	1726 mm	<b>5'8"</b>	1556 mm	<b>5'1"</b>	—	
<b>D — Minimum Opening</b>	1506 mm	<b>4'11"</b>	1828 mm	<b>5'11.95"</b>	694 mm	<b>2'3"</b>
<b>E — Maximum Clamp Opening</b>	2794 mm	<b>9'2"</b>	2990 mm	<b>9'9"</b>	3073 mm	<b>10'1"</b>
<b>Weight, Approximate</b>	1585 kg	<b>3491 lb</b>	3175 kg	<b>7000 lb</b>	3262 kg	<b>7191 lb</b>

**NOTE:** Third valve required. Counterweight recommended.

Logging forks with millyard style clamps are available where logging application requires clamp to close between tines.

The 950H, 962H and 966H are not available in all regions. Contact your local Cat dealer for product availability.

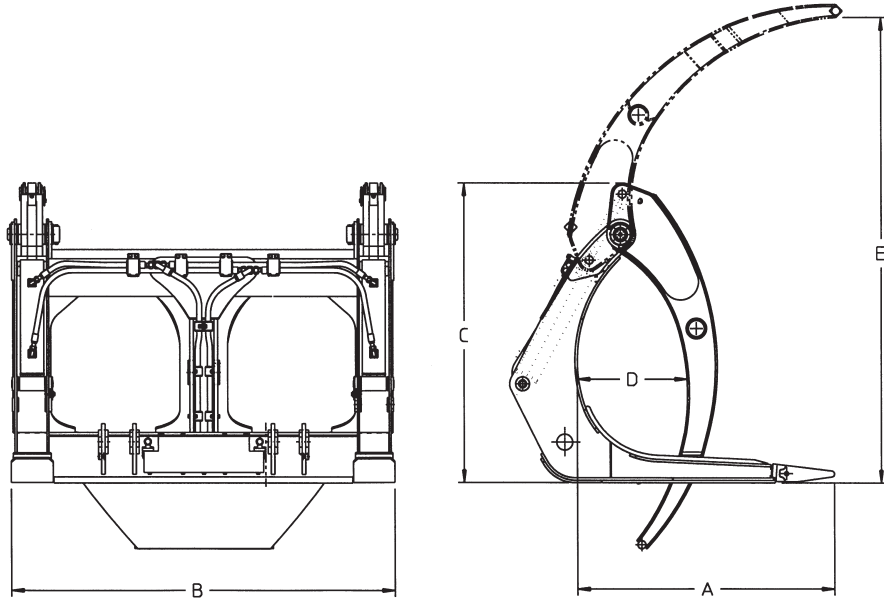

MODEL	950M/962M		950K/950M		962K/962M		966K/966M	
Model	Millyard Fork		Unloading Grapple Fork		Unloading Grapple Fork		Millyard Fork	
Group Number	374-7148		377-0722		352-7339		253-7320	
Logging Arrangement	374-7148		377-0722		352-7339		253-7320	
A – Tine Length	1609 mm	64"	762 mm	2'6"	917 mm	3'0"	1618 mm	5'4"
B – Overall Width	2324 mm	92"	1832 mm	6'0"	1850 mm	6'1"	2419 mm	8'0"
C – Back Height	–		–		–		–	
D – Minimum Opening	427 mm	17"	1336 mm	4'5"	1450 mm	4'9"	656 mm	2'2"
E – Maximum Clamp Opening	2709 mm	107"	2785 mm	9'2"	3123 mm	10'3"	2923 mm	9'7"
Weight, Approximate	2660 kg	5865 lb	1929 kg	4253 lb	2144 kg	4727 lb	2683 kg	5913 lb

MODEL	980K/980M		988K		988K	
Model	Millyard Fork		Double Top Clamp		Millyard Top Clamp	
Group Number	384-7540		210-9208		273-3209	
Logging Arrangement	384-7540		210-9208		273-3209	
A – Tine Length	1829 mm	6'0"	2509 mm	8'3"	2508 mm	8'2"
B – Overall Width	2761 mm	9'1"	2774 mm	9'1"	2870 mm	9'5"
C – Back Height	–		2783 mm	9'2"	–	
D – Minimum Opening	582 mm	1'11"	–		998 mm	3'3"
E – Maximum Clamp Opening	2951 mm	9'8"	3997 mm	13'1"	3911 mm	12'9"
Weight, Approximate	3958 kg	8726 lb	6696 kg	14,760 lb	7428 kg	16,376 lb

NOTE: Third valve required. Counterweight recommended.  
Logging forks with millyard style clamps are available where logging application requires clamp to close between tines.

The 980H is not available in all regions. Contact your local Cat dealer for product availability.

## **Features — Couplers**

### **Fusion Couplers**

- Fusion Quick Couplers provide unmatched versatility to any loader. Change tools in seconds without leaving the cab. Any work tool backed by coupler hooks can be picked up; allowing the loader to fit whatever application is at hand.

### **Center-Lock™ Pin Grabber Couplers**

- The Cat Center-Lock Pin Grabber Coupler allows buckets and other standard work tools to be used without any modification. Exchanging work tools in seconds improves overall production and increases machine versatility. The Coupler is pinned on in place of the bucket with standard pins, and can be easily removed should the need arise to mount a tool directly to the stick.
- The Center-Lock Coupler offers new possibilities. Buckets can be turned around and used in front shovel mode for final trench clean up. An integral lift eye on the coupler body allows lifting without the weight of the bucket, increasing both machine capacity and visibility from the cab.

## **Features — Buckets and Thumbs**

### **Cat Bucket Thumbs for Hydraulic Excavators**

- Multiply the performance of a Cat Excavator by adding a Cat Bucket Thumb. This highly versatile work tool acts in conjunction with the bucket to allow the excavator to grab irregularly shaped items and load loose materials and debris.

### **Mini Bucket Thumbs**

- Cat Bucket Thumbs are matched to Hydraulic Excavator Buckets for increased on-the-job performance. A thumb works with the bucket to grab, pick and sort debris, brush, trash and rock, opening up new production opportunities for your Cat Mini Excavator. Thumbs are an ideal complement to excavators working in demolition, land clearing, landscaping, material handling and construction jobs.

### **Clamshell Buckets**

- Cat Clamshell Buckets are the premier tools for cleanup, demolition, ground clearing and forestry work. Built of heavy T1 steel, these buckets are tough and durable for long service life in the most difficult applications. Clamshell buckets feature continuous 360° rotation, powered by a high-torque hydraulic motor.

**Features:****Buckets, U-blades, Bowldozers, Chip Scoops**

- The high-capacity, high-efficiency design of these tools makes them high-production workhorses. They are matched to specific machines and material densities for optimum performance. The extra capacity and load retention capabilities ensure maximum usage and productivity.

<b>WHEEL TRACTOR MODEL</b>	<b>824H</b>		<b>834H</b>	
Blade:				
Capacity	24 m <sup>3</sup>	<b>31.4 yd<sup>3</sup></b>	29.8 m <sup>3</sup>	<b>39 yd<sup>3</sup></b>
Length (cutting width)	4.78 m	<b>15'7"</b>	6.09 m	<b>20'0"</b>
Height	2.24 m	<b>7'4"</b>	2.24 m	<b>7'4"</b>
Wing angle		<b>30°</b>		<b>30°</b>
Weight, Installed (without hydraulics)				
BD (S) Dozer	3630 kg	<b>8000 lb</b>	4627 kg	<b>9470 lb</b>

<b>WHEEL TRACTOR MODEL</b>	<b>814F Series II</b>		<b>824H</b>		<b>834H</b>	
Chip Scoop:						
Lift and Carrying Capacity	15.3 m <sup>3</sup>	<b>20 yd<sup>3</sup></b>	20.6 m <sup>3</sup>	<b>27 yd<sup>3</sup></b>	34.4 m <sup>3</sup>	<b>39.5 yd<sup>3</sup></b>
Dozing Capacity	30.4 m <sup>3</sup>	<b>40 yd<sup>3</sup></b>	41.3 m <sup>3</sup>	<b>54 yd<sup>3</sup></b>	49.4 m <sup>3</sup>	<b>65 yd<sup>3</sup></b>
Width	3.73 m	<b>12'3"</b>	4.03 m	<b>13'3"</b>	4.83 m	<b>15'10"</b>
Height	2.29 m	<b>7'6"</b>	2.79 m	<b>9'2"</b>	2.25 m	<b>7'4"</b>
Depth	2.46 m	<b>8'1"</b>	2.95 m	<b>9'8"</b>	3.02 m	<b>9'11"</b>
Weight	5390 kg	<b>11,880 lb</b>	11 420 kg	<b>19,125 lb</b>	11 105 kg	<b>24,480 lb</b>

**NOTE:** For specifications of Woodchip Dozers used on track-type tractors, see the Bulldozer section in this handbook.

**Features — Rakes**

**Loader, Clearing and Clamp and Blade Rakes**

- Rakes are durable, high-capacity tools that will increase production for land clearing, site cleanup and site preparation. Available in quick coupler and pin-on models, rakes pile brush, stack and carry debris and load trucks. Features include thick, fabricated teeth, a heavy-duty push bar and serrated tree pusher. A high brush rack retains the load, prevents back spillage and increases carrying capacity.

## USE OF LOG VOLUME TABLES

The tabulated volumes on these pages were calculated with no taper in log diameter from base to top. Therefore each value listed in the table represents the volume of a true cylinder. In practice this may occur only in short sections of large diameter trees. To obtain the volume of solid wood logs, excluding bark:

1. Establish the base diameter of the log inside the bark and above the butt flare (extreme end taper).
2. Repeat the procedure for the top (small end) of log.
3. Enter log volume table at each of the two established diameters. Move horizontally to the vertical column closest to the length of the log being measured.
4. Establish the volume figures for each end of the log, add the two together and divide by two to obtain average log volume.

**METRIC LOG VOLUMES (in Cubic Meters)**

Log Diameter (cm)	LOG LENGTH (METERS)														
	2	4	6	8	10	12	14	16	18	20	22	24	26	28	30
10	0.016	0.031	0.047	0.063	0.078	0.094	0.12	0.13	0.14	0.16	0.17	0.19	0.20	0.22	0.24
15	0.035	0.071	0.11	0.14	0.18	0.21	0.25	0.28	0.32	0.35	0.39	0.42	0.46	0.49	0.53
20	0.06	0.13	0.19	0.25	0.31	0.38	0.44	0.50	0.57	0.63	0.69	0.75	0.82	0.86	0.94
25	0.10	0.20	0.30	0.39	0.49	0.59	0.69	0.79	0.88	0.98	1.08	1.18	1.28	1.37	1.47
30	0.14	0.28	0.42	0.57	0.71	0.85	0.99	1.13	1.27	1.42	1.56	1.70	1.84	1.98	2.12
35	0.19	0.38	0.58	0.7	0.96	1.15	1.35	1.54	1.73	1.93	2.12	2.31	2.50	2.69	2.89
40	0.25	0.50	0.75	1.01	1.26	1.51	1.77	2.02	2.27	2.52	2.78	3.02	3.27	3.51	3.77
45	0.32	0.64	0.95	1.27	1.59	1.91	2.22	2.54	2.86	3.18	3.50	3.82	4.13	4.45	4.77
50	0.39	0.79	1.18	1.57	1.96	2.36	2.76	3.16	3.54	3.94	4.34	4.71	5.10	5.49	5.89
55	0.48	0.95	1.43	1.90	2.38	2.85	3.33	3.80	4.28	4.75	5.23	5.70	6.18	6.65	7.12
60	0.57	1.13	1.70	2.26	2.83	3.39	3.96	4.52	5.09	5.65	6.22	6.78	7.35	7.92	8.48
65	0.66	1.33	1.99	2.65	3.32	3.98	4.65	5.31	5.98	6.64	7.30	7.96	8.62	9.29	9.95
70	0.77	1.54	2.31	3.08	3.85	4.62	5.40	6.15	6.93	7.70	8.48	9.23	10.0	10.77	11.54
75	0.88	1.77	2.65	3.53	4.42	5.30	6.19	7.06	7.95	8.84	9.72	10.60	11.49	12.37	13.25
80	1.01	2.01	3.02	4.02	5.03	6.03	7.05	8.06	9.07	10.08	11.09	12.10	13.10	14.10	15.10
85	1.13	2.27	3.40	4.54	5.67	6.81	7.94	9.08	10.20	11.32	12.47	13.62	14.75	15.89	17.02
90	1.27	2.54	3.82	5.09	6.36	7.63	8.90	10.17	11.43	12.71	13.99	15.27	16.54	17.81	19.10
95	1.42	2.84	4.26	5.67	7.09	8.51	9.92	11.33	12.76	14.18	15.60	17.01	18.43	19.85	21.26
100	1.57	3.14	4.71	6.28	7.85	9.42	11.0	12.58	14.16	15.72	17.30	18.85	20.42	22.0	23.56
125	2.45	4.90	7.36	9.82	12.27	14.73	17.18	19.6	22.1	24.5	27.0	29.5	32.0	34.4	36.8
150	3.53	7.1	10.6	14.1	17.7	21.2	24.7	28.3	31.8	35.3	38.8	42.4	45.9	49.5	53.0
175	4.8	9.6	14.5	19.2	24.0	28.9	33.7	38.5	43.3	48.1	53.0	57.7	62.6	67.3	72.2
200	6.3	12.6	18.8	25.1	31.4	37.7	44.0	50.3	56.5	62.8	69.1	75.4	81.7	88.0	94.2



**ENGLISH MEASURE LOG VOLUMES (in Cubic Feet)**

Log Diameter (inches)	LOG LENGTH (FEET)																	
	8	12	16	20	24	28	32	36	40	44	48	52	56	60	70	80	90	100
4	0.7	1	1.4	1.7	2.1	2.4	2.8	3.1	3.5	3.8	4.2	4.5	4.9	5.2	6.1	7	7.8	8.7
6	1.6	2.4	3.1	3.9	4.7	5.5	6.3	7.1	7.8	8.6	9.4	10	11	12	13	16	18	20
8	2.8	4.2	5.6	7	8.4	9.8	11	13	14	15	17	18	19	21	24	28	31	35
10	4.4	6.5	8.7	11	13	15	17	20	22	24	26	28	31	33	38	44	49	55
12	6.3	9.4	13	16	19	22	25	28	31	35	38	41	44	47	55	63	71	79
14	8.5	13	17	21	26	30	34	39	43	47	51	56	60	64	74	86	96	101
16	11	17	22	28	34	39	45	50	56	61	67	73	78	84	98	112	126	140
18	14	21	28	35	42	49	57	64	71	78	85	92	99	106	124	141	159	177
20	17	26	35	44	52	61	70	79	87	96	105	113	122	131	153	175	196	218
22	21	32	42	53	63	74	85	95	106	116	127	137	148	158	185	211	238	264
24	25	38	50	63	75	88	101	113	126	138	151	163	176	189	220	251	283	314
26	29	44	59	74	89	103	118	133	147	162	177	192	207	221	258	295	332	369
28	34	51	68	86	103	120	137	154	171	188	205	222	240	256	299	342	385	428
30	39	59	79	98	118	137	157	177	196	216	236	255	275	295	344	393	442	491
32	45	67	89	118	134	156	179	201	223	246	268	290	313	335	391	447	503	559
34	50	76	101	126	151	177	202	227	252	277	303	328	353	378	441	504	567	631
36	57	85	113	141	170	198	226	255	282	311	339	368	396	424	495	566	637	707
38	63	95	126	158	189	220	252	284	315	347	378	410	441	473	551	630	709	788
40	70	105	140	175	210	244	279	314	349	384	419	454	489	524	611	698	785	873
50	109	164	218	273	327	382	436	491	545	600	645	709	764	818	955	1091	1227	1364
60	157	234	314	393	471	550	628	707	785	864	943	1021	1100	1178	1374	1571	1767	1964
70	214	321	428	535	642	748	855	962	1069	1176	1283	1389	1497	1604	1871	2138	2405	2673
80	279	420	559	698	838	977	1117	1257	1396	1536	1676	1815	1955	2095	2441	2293	3142	3491

**WEIGHTS OF COMMERCIALLY IMPORTANT WOODS**

Species	kg/m <sup>3</sup> (Green)	lb/ft <sup>3</sup> (Green)	Species	kg/m <sup>3</sup> (Green)	lb/ft <sup>3</sup> (Green)
<b>A. Temperate Zone*</b>			Maple, Big Leaf . . . . .	753	47
Alder, Red . . . . .	737	46	Black . . . . .	865	54
Ash, White . . . . .	769	48	Red . . . . .	801	50
Aspen . . . . .	689	43	Silver . . . . .	721	45
Baldcypress . . . . .	817	51	Sugar . . . . .	897	56
Basswood . . . . .	673	42	Oak, Black . . . . .	1009	63
Beech . . . . .	865	54	Chestnut . . . . .	977	61
Birch, Paper . . . . .	801	50	Red . . . . .	1009	63
Yellow . . . . .	929	58	Red, Swamp . . . . .	1073	67
Cedar, Alaska . . . . .	577	36	Swamp Chestnut . . . . .	1041	65
Incense . . . . .	721	45	White . . . . .	993	62
Northern, White . . . . .	449	28	White, Swamp . . . . .	1105	69
Port-Orford . . . . .	897	56	Pine, Jack . . . . .	801	50
Western Red . . . . .	433	27	Loblolly . . . . .	993	62
Cherry, Black . . . . .	721	45	Lodgepole . . . . .	625	39
Cottonwood, Eastern . . . . .	785	49	Long Leaf . . . . .	993	62
Douglas Fir, (Coast) . . . . .	881	55	Norway (Red) . . . . .	673	42
(Inland Empire) . . . . .	577	36	Short Leaf . . . . .	993	62
Elm, American . . . . .	865	54	Slash . . . . .	993	62
Fir, Alpine . . . . .	449	28	Sugar . . . . .	817	51
Balsam . . . . .	721	45	Western Yellow, (Ponderosa) . . . . .	721	45
Nobel . . . . .	481	30	White (Western) . . . . .	561	35
Red . . . . .	769	48	White (Eastern) . . . . .	577	36
Silver . . . . .	577	36	Poplar, Yellow . . . . .	609	38
White . . . . .	753	47	Redwood . . . . .	801	50
Gum, Black . . . . .	721	45	Spruce, Black . . . . .	513	32
Blue . . . . .	1121	70	Engleman . . . . .	625	39
Red . . . . .	801	50	Red . . . . .	545	34
Tupelo . . . . .	897	56	Sitka . . . . .	529	33
Hemlock, Eastern . . . . .	801	50	White . . . . .	545	34
Western . . . . .	961	60	Sweetgum . . . . .	801	50
Hickory, Pecan . . . . .	993	62	Sycamore . . . . .	833	52
True . . . . .	1009	62	Tamarack . . . . .	753	47
Larch, Western . . . . .	769	48	Walnut, Black . . . . .	929	58
Locust, Black . . . . .	929	58	Willow, Black . . . . .	801	50
Magnolia, Cucumber . . . . .	785	49			

\*NOTE: Weights taken from U.S. Dept. of Agriculture handbook No. 72, Wood Handbook.

- Southeast Asia
- West Africa

Species	kg/m <sup>3</sup> (Green)	lb/ft <sup>3</sup> (Green)
<b>B. Southeast Asia</b>		
Apitong .....	961	<b>60</b>
Bintangor.....	865	<b>54</b>
Chumprak .....	929	<b>58</b>
Ebony.....	1746	<b>109</b>
Geronggang .....	721	<b>45</b>
Jelutong.....	641	<b>40</b>
Kapur (Borneo Camphorwood)....	1073	<b>67</b>
Keruing .....	1121	<b>70</b>
Krabak .....	817	<b>51</b>
Kruen .....	1121	<b>70</b>
Lumbayau .....	929	<b>58</b>
Mahogany, Philippine.....		
(Red Luan).....	753	<b>47</b>
(White Luan) .....	769	<b>48</b>
(Yellow Luan) .....	769	<b>48</b>
Mahoni .....	913	<b>57</b>
Alayan Kauri (Damar Minyak) .....	817	<b>51</b>
Melantai.....	705	<b>44</b>
Melapi .....	849	<b>53</b>
Mangkulang .....	929	<b>58</b>
Meranti Bakau.....	849	<b>53</b>
Meranti, Dark Red.....	753	<b>47</b>
White.....	769	<b>48</b>
Yellow .....	769	<b>48</b>
Mersawa .....	817	<b>51</b>
Nyatoh.....	897	<b>56</b>
Palosapis .....	817	<b>51</b>
Pulai .....	545	<b>34</b>
Ramin.....	1073	<b>67</b>
Rosewood (Sonokelina).....	1314	<b>82</b>
Seraya, Dark Red.....	753	<b>47</b>
Yellow.....	769	<b>48</b>
White .....	769	<b>48</b>
Teak .....	1073	<b>67</b>

Species	kg/m <sup>3</sup> (Green)	lb/ft <sup>3</sup> (Green)
<b>C. West Africa</b>		
Abura.....	850	<b>53.06</b>
Ako.....	800	<b>49.94</b>
Azobe .....	1300	<b>81.16</b>
Aniegre (Mukali) .....	950	<b>59.31</b>
Bete .....	900	<b>56.19</b>
Bosse .....	900	<b>56.19</b>
Bubinga .....	1000	<b>62.43</b>
Dibetau .....	750	<b>46.82</b>
Douka (Makore).....	950	<b>59.31</b>
Doussie .....	1200	<b>74.91</b>
Framire .....	850	<b>53.06</b>
Fromager.....	550	<b>34.34</b>
Iloba .....	750	<b>46.82</b>
Iroko.....	1200	<b>74.91</b>
Kokrodua (Afromosia).....	1000	<b>62.43</b>
Kosipo .....	900	<b>56.19</b>
Limba.....	750	<b>46.82</b>
Mahogany .....	750	<b>46.82</b>
Moabi.....	1100	<b>68.67</b>
Niangon.....	900	<b>56.19</b>
Okoume.....	650	<b>40.57</b>
Ozigo .....	900	<b>56.19</b>
Padouk.....	1000	<b>62.43</b>
Samba (Obeche).....	650	<b>40.58</b>
Sapelli .....	900	<b>56.19</b>
Sipo .....	800	<b>49.94</b>
Tchitola .....	850	<b>53.06</b>
Tiaba .....	900	<b>56.19</b>
Tola.....	850	<b>53.06</b>

# Weights of Commercially Important Woods

- Australia
- New Zealand
- Papua New Guinea

# Forest Products Tables

Species	kg/m <sup>3</sup> (Green)	lb/ft <sup>3</sup> (Green)
<b>D. Australia</b>		
Ash Alpine . . . . .	1041	65
Mountain . . . . .	1009	63
Silvertop . . . . .	1330	83
Black Butt . . . . .	1121	70
Box Long Leaf . . . . .	993	62
Yellow . . . . .	1105	69
Black . . . . .	1105	69
Brownbarrel . . . . .	1073	67
Candle Bark . . . . .	657	41
Gum Grey . . . . .	1217	76
Manna . . . . .	1121	70
Mountain . . . . .	1169	73
Mountain Grey . . . . .	1057	66
River Red . . . . .	1137	71
Forest Red . . . . .	1201	75
Southern Blue . . . . .	1217	76
Spotted . . . . .	1201	75
Sydney Blue . . . . .	1153	72
Iron Bark Gray . . . . .	1330	83
Narrowleaved . . . . .	1330	83
Red . . . . .	1330	83
Jarrah . . . . .	1169	73
Karri . . . . .	1169	73
Mahogany Red . . . . .	1153	72
White . . . . .	1282	80
Myrtle . . . . .	1169	73
Peppermint . . . . .	1120	70
Pine Radiata . . . . .	865	54
Monerey . . . . .	865	54
Celerytop . . . . .	1057	66
Stringy Bark Brown . . . . .	1233	77
Messmate . . . . .	1169	73
Yellow . . . . .	1217	76
White . . . . .	1121	70
Tallowwood . . . . .	1201	75
Wandoo . . . . .	1282	80

Species	kg/m <sup>3</sup> (Green)	lb/ft <sup>3</sup> (Green)
<b>E. New Zealand</b>		
Exotic Softwoods . . . . .		
Radiata Pine . . . . .	1000	62
Douglas Fir . . . . .	734	45
Corsican Pine . . . . .	985	61
Redwood . . . . .	1016	63
Larch . . . . .	960	60
Indigenous Softwoods . . . . .		
Mati . . . . .	1120	70
Rimu . . . . .	1130	70
Exotic Hardwoods . . . . .		
Eucaliptus Botryoides . . . . .	893	56
Eucaliptus Saligna . . . . .	1200	75
Indigenous Hardwoods . . . . .		
Beech — Silver . . . . .	920	57
Beech — Red . . . . .	1200	75
Tawa . . . . .	1022	64

Species	kg/m <sup>3</sup> (Green)	lb/ft <sup>3</sup> (Green)
<b>F. Papua New Guinea</b>		
Pine, Hoop . . . . .	520	32
Kauri . . . . .	480	30
Klinki . . . . .	510	31
Kwila . . . . .	800	50
Erima . . . . .	390	24
Taun . . . . .	680	42
Walnut, PNG . . . . .	560	35
Cedar, Pencil . . . . .	720	50
Mersawa . . . . .	650	40
Celtis, Hard . . . . .	780	48
Rosewood, PNG . . . . .	600	37
Beech, PNG . . . . .	830	51
Oak, PNG . . . . .	650	40
Ebony, PNG Black . . . . .	1115	69
PNG White . . . . .	720	50
Hardwood, Yellow . . . . .	780	48
Hopea, Heavy . . . . .	960	60
Light . . . . .	710	44
Podocarp, Black . . . . .	410	25
Terminalia, Brown . . . . .	450	28

**ESTIMATING NUMBER OF TREES PER HECTARE**

Spacing (Meters)	Spacing (Meters)							
	1	2	3	4	5	6	7	8
1	10 000	5000	3333	2500	2000	1667	1428	1250
2	5000	2500	1667	1250	1000	834	714	625
3	3333	1667	1111	834	667	556	477	417
4	2500	1250	834	625	500	417	357	313
5	2000	1000	667	500	400	330	286	250
6	1667	834	556	417	333	278	238	208
7	1428	714	477	357	286	238	204	179
8	1250	625	417	313	250	208	179	156

**ESTIMATING NUMBER OF TREES PER ACRE**

Spacing (Feet)	Spacing (Feet)							
	5	6	7	8	9	10	11	12
5	1742	1452	1244	1089	968	871	792	726
6	1452	1210	1037	907	806	726	660	605
7	1244	1037	888	777	691	622	565	518
8	1089	907	777	680	605	544	495	453
9	968	806	691	605	537	484	440	403
10	871	726	622	544	484	435	396	363
11	792	660	565	495	440	396	360	330
12	726	605	518	453	403	363	330	302
13	671	558	478	418	372	335	304	279
14	622	518	444	390	346	311	283	259
15	580	484	415	363	323	290	264	242

**COMPARISON OF LOG RULES ● Board Foot Values for 16-Foot Logs**

Diameter at Small End, Inside Bark, Inches	International 1/4 Inch	Scribner	Scribner Decimal	Spaulding	Doyle
4	5	10	10	—	—
6	20	18	20	—	4
8	40	32	30	—	16
10	65	54	60	50	36
12	95	79	80	77	64
14	135	114	110	114	100
16	180	159	160	161	144
18	230	213	210	216	196
20	290	280	280	276	256
22	355	334	330	341	324
24	425	404	400	412	400
26	500	500	500	488	484
28	585	582	580	569	576
30	675	657	660	656	676
32	770	736	740	748	784
34	875	800	800	845	900
36	980	923	920	950	1024
38	1095	1068	1070	1064	1156
40	1220	1204	1200	1185	1296

**UNIT OF MEASUREMENT DEFINITIONS**

1 board foot	= 1/12 ft <sup>3</sup> of solid wood (1' × 1' × 1")
1000 board feet	= 83.33 ft <sup>3</sup> of solid wood
1 c. unit of wood	= 100 solid ft <sup>3</sup> = 1200 board feet = 2.83 <sup>3</sup>
1 cord of wood	= 128 ft <sup>3</sup> of stacked logs = 3.62 m <sup>3</sup>
1 unit of wood	= 200 ft <sup>3</sup> of loose chips = 5.66 m <sup>3</sup>
1 cord of wood	= 0.85 units
1 Hoppus Ton	= 50 ft <sup>3</sup> (assumed) = 63.65 ft <sup>3</sup> (actual) = 600 board feet = 763.8 BF Brereton = 1.8 m <sup>3</sup> actual = 1.4 m <sup>3</sup> assumed
1 cubic meter	= 35.32 ft <sup>3</sup> = 424 board feet = 333 board feet Hoppus tons = 0.555 Hoppus Tons
1 MBF Brereton	= 2.36 m <sup>3</sup> = 785.4 board feet Hoppus
1 MBF Hoppus	= 1273 board feet-Brereton
MBF	= Thousand board feet
1 Super Foot	= 1 board foot
100 Super Feet	= 1000 board foot = 0.236 m <sup>3</sup>
600 Super Feet	= 50 ft <sup>3</sup>
1 lb/ft <sup>3</sup>	= 16.0185 kg/m <sup>3</sup>

**CUBIC FEET OF SOLID WOOD PER CORD**

Length of Sticks-Ft.	Diameter at Small End		
	1"-2.5"	2.5"-5.5"	Over 5.5"
2	65	84	91
4	64	82	89
8	59	77	84
12	54	71	78

**RULE OF THUMB CONVERSIONS**

1 c. unit of wood	= 1.117 cords = 1.25 units of chips = 250 ft <sup>3</sup> of chips = 7.08 m <sup>3</sup>
1 cord of wood	= 85 ft <sup>3</sup> of solid wood = 1.06 units of chips = 2.41 m <sup>3</sup>
1 unit of chips	= 80 ft <sup>3</sup> of solid wood = 2.27 m <sup>3</sup>
1 cord of wood	= 500 board feet = 1.18 m <sup>3</sup>
2000 pounds of chips	= 500 pounds of pulp
1 cord	= 212 ft <sup>3</sup> of chips = 6 m <sup>3</sup>



# HIGHWALL MINING SYSTEM

## CONTENTS

### HW300

Product Line Description . . . . .	6-1
Features . . . . .	6-1
Highwall Mining Method . . . . .	6-2
Highwall Miner Applications . . . . .	6-2
Cutter Module . . . . .	6-3
Power Head . . . . .	6-3
Mobility . . . . .	6-3
Operator Comfort . . . . .	6-3
Push Beams . . . . .	6-4
Reel and Chain . . . . .	6-4
Control System . . . . .	6-4
Anchoring System . . . . .	6-4
Equipment Relocation . . . . .	6-5
Safety . . . . .	6-5
Support . . . . .	6-5
Specifications . . . . .	6-6
Dimensions . . . . .	6-9
Optional Equipment . . . . .	6-10



## PRODUCT LINE DESCRIPTION

Linking underground and surface mining operations, the Cat® Highwall Mining System is a low cost solution for mining coal. The HW300 offers a safe and innovative method for extracting coal from exposed seams in a multitude of applications.

## HW300 FEATURES

- **Maximum Extraction** — Low cost coal to traditional mining methods.
- **Safe Operation** — The entire mining cycle is completed by a three- or four-man crew, with no personnel going underground at any time.
- **Excellent Mobility** — The highwall miner trams easily from entry to entry and discharges coal in tight spaces.
- **Operator Comfort** — The air-conditioned cab offers an ergonomic workplace where all controls are within the operator's reach.
- **Easy Equipment Relocation** — The highwall mining system can be taken apart in modules — sized for transport using regular public roads.
- **Cutter Module Choices** — Caterpillar offers four different cutter modules for the Highwall Miner: extra low seam, low seam, mid seam and high seam.

**NOTE:** The low and extra low seam cutter modules are not available in some regions.



## HIGHWALL MINING METHOD

### Feasibility Determination

Highwall mining can produce exceptionally low cost coal if conditions are right. Having the right geology and environmental conditions is the key to success. Caterpillar and its dealers can assist you with an in depth evaluation of the site. For a very high-level evaluation, you can start by going to the Highwall Miner page on [www.cat.com](http://www.cat.com) and use the on-line site evaluation tool.

### Extracting Coal Affordably and Safely

Highwall mining is a proven and versatile primary method for mining coal from exposed seams.

The Cat HW300 highwall miner stands on the pit floor or on a bench, directly in front of the exposed seam and makes long parallel rectangular drives into the coal seam. Pillars of material are left in place between the entries to support the over burden.

A remote-operated cutter module is pushed up to 300 m (1000 ft) into the seam by a string of push beams (unmanned coal-conveying elements) that transport the mined coal back to the entry of the drive onto a stockpile. The whole mining cycle is completed by a three- or four-man crew, with no personnel going underground at any time.

The self-contained and self propelled Cat highwall mining system offers an innovative method for extracting coal from exposed seams in a multitude of applications.

Whether you're operating a trench, open cast or contour mine, the Cat highwall mining system can extract coal affordably and safely:

- **Open Cast** — Highwall mining is used to mine coal from underneath the final highwall, when the strip limit is reached due to economic reasons or surface conditions.
- **Trench Mining** — The unit mines coal from both sides of a purpose-prepared trench; this mining method is used when an open pit is not an option.
- **Contour Mining** — In a mountainous area, the Cat highwall mining system can follow a coal seam along the side of the hill.

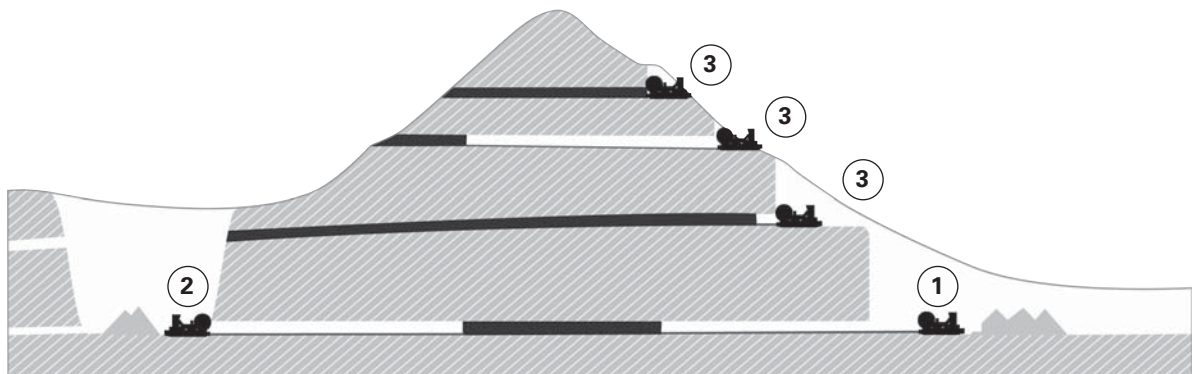

### HIGHWALL MINER APPLICATIONS

- ① **Open Cast Pit Mining**
- ② **Trench Mining (mining seams on both sides)**
- ③ **Contour Mining**

## CUTTER MODULE

### Proven Cutter Module

Caterpillar offers four separate cutter modules for the HW300: extra low seam, low seam, mid seam and high seam.

### Recommended Seam Heights

Extra Low Seam	711 to 1549.4 mm	<b>28 to 61 in</b>
Low Seam	762 to 1500 mm	<b>30 to 59 in</b>
Mid Seam	1200 to 3050 mm	<b>47.2 to 120 in</b>
High Seam	2400 to 4500 mm	<b>94.5 to 177 in</b>

The cutter modules are interchangeable and quickly attach to the power head assembly. The cutting cycle is fully automated, yet allows the operator to manually adjust the machine function using an ampere reading as the coal seam varies. This proven technology allows the cutter module to accurately follow the coal seam and produce a cleaner product.

### Advanced Technology

For even more accurate directional mining operation, Caterpillar offers an optional solid-state, fiber-optic, gyro-based navigation and steering system. This provides operators with very precise cutter module location data in real time for enhanced cutter module steering and pillar width control.

An optional Gamma Detection system can be used to guide the cutter module through the coal seam, leaving predetermined amounts of coal in the roof and floor. This system also allows the mining of coal in soft roof and/or soft floor situations.

## POWER HEAD

### Heavy Duty Power Head Assembly

The power head drives the cutter module and push beam string forward using two hydraulically-powered sump cylinders with a 6.86 m (22.5 ft) stroke.

The pushing force of 133 tonnes (147 tons) propels the cutter module to a depth of 300 m (1000 ft) and the pulling force of 275 tonnes (303 tons) retracts it safely.

The new standard sump cylinders have higher sump- and retract forces.\*

\*Applies to international customers only. Not available in the USA.

## MOBILITY

### Improved Maneuverability in Tight Spaces

The Cat highwall mining system is an agile, self-propelled machine that operates on contour benches as narrow as 18 m (59 ft). It trams easily from entry to entry and discharges coal in tight spaces. An optional right-angle conveyor system discharges coal on the right or left side on narrow benches. It can also discharge onto a stacking conveyor system, where coal is moved to the center of the bench for stockpiling large volumes.

Four heavy-duty, hydraulically-powered tracks articulate independently in two operating modes — mine mode and tram mode — and can rotate the machine 360°, which improves maneuverability in congested areas. Mine mode is used for moving parallel to the highwall, while tram mode is used when moving from pit to pit.

## OPERATOR COMFORT

### Ergonomic Design for Comfort, Control and Productivity

The Cat highwall mining system is equipped with a comfortable, climate controlled, pressurized cab that offers a full view of the mining operation and the highwall. A full suspension seat and two adjustable touchscreen displays provide an ergonomic environment, placing machine controls and system information at the operator's fingertips.

### PUSH BEAMS

#### Backbone of the Highwall Mining System

Cat push beams are 6 m (20 ft) long, rectangular, reinforced steel box structures joined together to form a string, which connects the highwall mining system to the cutter module.

The push beam string is the backbone of the machine; pushing and pulling the cutter module in and out of the coal seam.

The push beam conveys mined coal inside. The enclosed beam protects the coal from contamination and supports the hose chain that supplies control and power to the cutter module.

Other Cat push beam advantages include:

- A strong method of attachment that is secured and disengaged quickly
- A push beam connection that allows the string and cutter module to navigate through coal seam rolls and undulations
- A simple design free of electrical and hydraulic connections
- Push beams that can be stacked six high reducing storage area in narrow work sites, even under tough pushing and pulling conditions.

### REEL AND CHAIN

#### Storage and Protection of Cables and Hoses

A steel-armored hose chain stores and protects all electric power cables, hydraulic and coolant lines, and the control cable to the cutter module. The hose chain is automatically unrolled and retracted on a reel during mining.

### CONTROL SYSTEM

#### Control System with Diagnostics

The Cat highwall mining system's operation is controlled by a Programmable Logic Controller, which provides reliable performance for greater uptime. A comprehensive diagnostics system, including troubleshooting assistance, streamlines maintenance procedures.

#### Electric Controls

Motor Control Circuits (MCC) for the cutter module motors are housed on the surface in the Electrical Control Module (ECM). Underground electrical components are housed in flame-proof enclosures.

### ANCHORING SYSTEM

#### Maximum Stabilization even under Toughest Conditions

Two drills mounted on the front of the machine are used to drill into the pit floor up to 2.4 m (8 ft). High-strength pins are then inserted through the base frame into the pit floor to help stabilize the machine and to maintain its accurate position, even under tough pushing and pulling conditions.

## EQUIPMENT RELOCATION

### Convenient Modularity for Quick Assembly

For quick relocation over long distances, the Cat highwall mining system can be taken apart in modules. Rapid disassembly and reassembly is facilitated by convenient hydraulic and electrical connectors, and all modules are sized for transport using regular public roads.

Depending on local conditions, the system can also be transported between sites and without disassembly by heavy haul trucks.

## SAFETY

### Designed with Safety as the First Priority

The Cat highwall mining system is engineered and equipped with a priority on safe operation; safety features include:

- **Elevated Cab with Cameras** — For a complete view of the highwall mining system and mining operation, the FOPS certified operator cabin is elevated on the machine and three magnetic base cameras are provided whose positions can be easily and quickly adjusted.
- **Above-ground Operation** — Operation of the system is performed entirely on the surface with no crew members working underground.
- **Small-crew Size** — The highwall mining system only requires a three- to four-person crew for full operation.
- **Remote Operation** — In an emergency, the machine can be operated remotely using a laptop from as far away as 61 m (200 ft).
- **Anchoring System** — Two drills mounted on the front of the machine are used to drill into the pit floor up to 2.4 m (8 ft). High-strength pins are then inserted through the base frame into the pit floor to help stabilize the machine and to maintain its accurate position, even under tough pushing and pulling conditions.

- **Methane Sensor** — A methane sensor is mounted near the cutter drum. When the methane content in the air reaches the warning level, an automatic warning signal attends the crew. When the methane level reaches a pre-set maximum level, a warning signal attends the crew, and all electric power to the cutter module is automatically disconnected (Except to the methane sensor itself). Settings depend on local regulations.
- **Working safely at night** is enhanced by a number of LED Flood lights, as well as LED platform and interior lights. The platform and interior lights are backed-up by a battery system to stay on for up to 10 minutes after a power outage.
- **Hydraulic Controls** — Underground hydraulic valves are provided with flame proof solenoids.

## SUPPORT

### Product Support

Parts and service support for the HW300 are never far away with the global Cat Dealer Network. You can count on our dealers' skill and knowledge for quality maintenance and high parts availability. Since the machine will be serviced on site, this requires a trained crew with a dedicated maintenance truck, stocked with essential spares and consumables for the machine. Your dealer is happy to discuss this and other support services options.

### Training

Caterpillar can arrange operational and technical training which covers every aspect of the HW300 Highwall Miner.

### Support Equipment

The highwall miner has the following support equipment needs:

1. Two wheel loaders; one to load push beams during mining, one to manage the coal stock pile.
2. A stacker belt is recommended for managing the coal as it comes off the machine.
3. Equipment requirements for keeping the seam exposed will depend on the application.

**HW300 HIGHWALL MINING SYSTEM SPECIFICATIONS**

**Environmental and Operational Conditions**

The Cat HW300 is designed for the following environmental and operating conditions:

Mine Application	<ul style="list-style-type: none"> <li>• Trench Application</li> <li>• Open Pit Mining</li> <li>• Contour Mining</li> </ul>
Ambient Temperature	<ul style="list-style-type: none"> <li>• Standard Package (includes Tropical environment) –30° to +50° C (<b>-22° to +122° F</b>)</li> <li>• Arctic Package –40° to +50° C (<b>-40° to +122° F</b>) (change of hydraulic fluid required between seasons)</li> </ul>
Pit Floor Gradient	• 8 degrees nominal in any direction, 10 degrees maximum in any direction for traveling
Maximum Seam Gradient	• 8 degrees down dip relative to horizontal (level side-to-side, pit floor prepared at 2 degrees)

**Power and Consumption**

Electric Power (Installed) 995/460 VAC, 50/90 Hz Mid/High Seam Cutter Module and Right Angle Discharge

Function	Qty	Volts	Power (ea)		Power (Total)	
			kW	hp	kW	hp
Cutting Motors 60 Hz	2	995	179	<b>240</b>	358	<b>480</b>
Cutting Motors 50 Hz	2	995	149	<b>200</b>	298	<b>400</b>
Gathering Motors 60 Hz	2	995	34	<b>45</b>	67	<b>90</b>
Gathering Motors 50 Hz	2	995	41	<b>55</b>	82	<b>110</b>
Power Head Auger Motors	2	995	373	<b>500</b>	746	<b>1000</b>
Hydraulic Pump Motor	1	995	224	<b>300</b>	224	<b>300</b>
Base Frame Conveyor Motor	1	995	75	<b>100</b>	75	<b>100</b>
Right Angle Conveyor Motor	1	995	75	<b>100</b>	75	<b>100</b>
Stacking Conveyor Motor (Max) (Customer Equipment)	1	995	75	<b>100</b>	75	<b>100</b>
Cooling Fan Motors	6	460	1.5	<b>2</b>	9	<b>12</b>
Water Circulating Pump Motor	1	460	7	<b>10</b>	7	<b>10</b>
Hydraulic Oil Circulating Pump Motor	1	460	11	<b>15</b>	11	<b>15</b>
Water Spray Pump Motor	1	460	6	<b>8</b>	6	<b>8</b>
<b>Total Connected Power 60 Hz</b>	19				1651	<b>2215</b>
<b>Total Connected Power 50 Hz</b>	19				1607	<b>2155</b>

**Power for the Miner**

The miner can be powered from a utility grid or if being operated in remote areas, using a Cat generator set available from any Cat dealer.

The machine is provided with our 2250 kVA “Global Transformer,” which accepts the following standard power supply voltages (+ and – 5%):

60 Hz: 7.2 or 4.16 kV

50 Hz: 6.6 or 3.3 kV

**Water Consumption**

Water consumption for surface dust suppression during the mining operation is an average of 1000 L (**264 gal**) per hour (estimate).

## HW300 HIGHWALL MINING SYSTEM SPECIFICATIONS

### General Specifications

All dimensions and weights are approximate and depending on final specification.

Machine Dimensions while Mining	<ul style="list-style-type: none"> <li>• Width: 11.7 m <b>(38.5 ft)</b></li> <li>• Height: 8.7 m <b>(28.7 ft)</b></li> <li>• Length: LPCM: 20.3 m <b>(66.5 ft)</b> Mid Seam CM: 21.3 m <b>(70 ft)</b></li> </ul>
Machine Dimensions while Tramming	<ul style="list-style-type: none"> <li>• Width: 7.7 m <b>(25.3 ft)</b> Track Width</li> <li>• Height: 9.1 m <b>(30 ft)</b></li> <li>• Length: LPCM: 20.3 m <b>(66.5 ft)</b> Mid Seam CM: 21.3 m <b>(70 ft)</b></li> <li>• Minimum road width for overhanging structure: 9.2 m <b>(30.1 ft)</b> with right-angle conveyor removed.</li> </ul>
Weight	<ul style="list-style-type: none"> <li>• HWM without cutter head: 225 000 kg <b>(495,665 lb)</b></li> <li>• Push Beam Weight: 5330 kg <b>(11,750 lb)</b> — 54 pieces (54 push beams are standard for a system)</li> </ul>

6

### Extra Low Seam Cutter Modules

The extra low seam cutter module is specifically designed to work with the Cat HW300

Cutter Drum Diameter	• 65 cm <b>(25.5 in)</b>
Cutting Width	• 294 cm <b>(116 in)</b>
Drum Drive	• (2) 123 kW <b>(165 hp)</b> /995 VAC/60 Hz Electric Motors
Maximum Cutting Height	• 154 cm <b>(61 in)</b>
(2) Hydraulic cylinders with integrated liner transducers to measure cutting height.	
Gathering System	• Coal gathered by augers

### Low Seam Cutter Modules

The low profile cutter module is specifically designed to work with the Cat HW300

Cutter Drum Diameter	• 65 cm <b>(25.5 in)</b>
Cutting Width	• 2.95 m <b>(116 in)</b>
Drum Drive	• (2) 123 kW <b>(165 hp)</b> /995 VAC/60 Hz Electric Motors
Maximum Cutting Height	• 1.6 m <b>(63 in)</b>
(2) Hydraulic cylinders with integrated liner transducers to measure cutting height.	
Gathering System	• Coal gathered by augers

**Mid Seam Cutter Modules**

The mid cutter module is a Cat design that employs a CM235 Cutting Boom and gathering pan assembly.

Cutter Drum Diameter	• 965 mm <b>(38 in)</b>
Drum Width	• 3.5 m <b>(11 ft 6 in)</b>
Drum Drive	• (2) 175 kW <b>(235 hp)</b> /995 VAC/60 Hz
Gathering System	• CLA System

**High Seam Cutter Modules**

Cutter Drum Diameter	• 966 mm <b>(38 in)</b>
Cutting Width	• 3505 mm <b>(138 in)</b>
Minimum Recommended Seam Height	• 2400 mm <b>(94.5 in)</b>

**Optional**

Navigation and Steering*	<ul style="list-style-type: none"> <li>• An internal navigation device can be mounted in the cutter module for accurate heading and tracking of the position of the cutter module. The cutter head direction is automatically controlled by two steering arms (1 x L, 1 x R).</li> <li>*Steering not available on extra low or low seam cutter modules.</li> </ul>
Natural Gamma Sensor	<ul style="list-style-type: none"> <li>• Natural gamma sensors can be mounted to the top and/or the bottom of the cutter module. These sensors enables the operator to leave coal on the roof and/or floor to improve the coal quality or to enhance roof support in weak strata conditions.</li> </ul>

**DIMENSIONS** (All dimensions are approximate.)

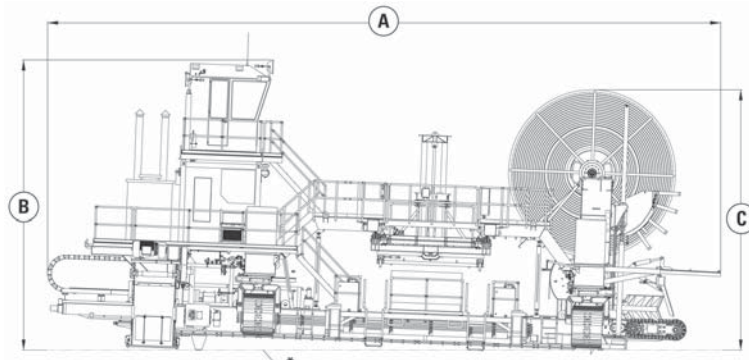

\*Ground Level

**Right Side View**

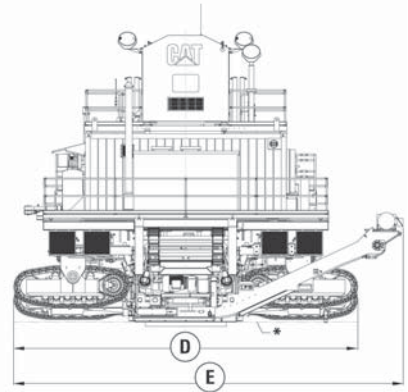

**Rear View**

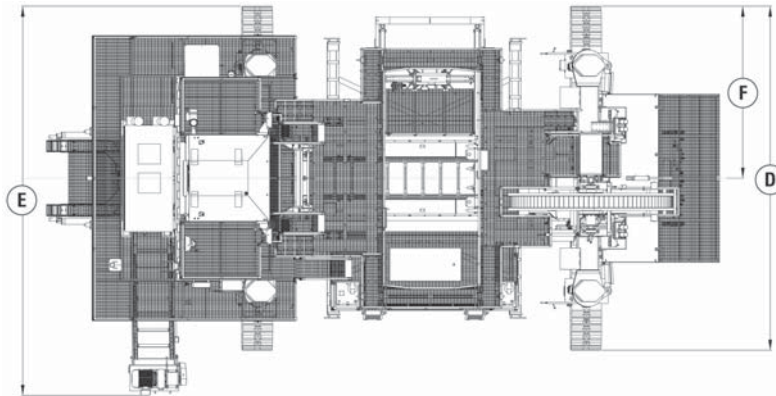

**Top View**

**MODEL**

**HW300**

MODEL	HW300	
<b>A</b> Overall Length	20 278 mm	<b>66.5 ft</b>
<b>B</b> Overall Height	8743 mm	<b>28.7 ft</b>
<b>C</b> Hose Reel Height	7844 mm	<b>25.7 ft</b>
<b>D</b> Track Width	10 369 mm	<b>34.0 ft</b>
<b>E</b> Overall Width	11 730 mm	<b>38.5 ft</b>
<b>F</b> Half Track Width	5185 mm	<b>17.0 ft</b>



**HW300 OPTIONAL EQUIPMENT**

Optional equipment may vary.  
Consult your Cat dealer for details.

**Right-Angle Discharge**

- This feature discharges coal to the right or left of the machine.

**Cat Push Beam Grapple**

- For the 966H/K/M with Fusion coupler, the following packages are available:

**489-5931 FORK, PUSH BEAM HANDLING (QC)**

This is the push beam grapple. A fork with fixed tines and double hydraulic clamps to transport 1 push beam at a time. With Fusion coupler hooks.

**314-3189 BUCKET-COAL, 3405 mm 6.70 m<sup>3</sup> (134 in 8.75 yd<sup>3</sup>) (QC)** Standard 6.7 m<sup>3</sup> (8.75 yd<sup>3</sup>) coal bucket. With Fusion coupler hooks. Requires: Edge group 109-9213 to be ordered separately.

**362-9276 BUCKET-GP, 3201 mm 4.20 m<sup>3</sup> (126 in 5.5 yd<sup>3</sup>) (QC)** Standard 4.2 m<sup>3</sup> (5.5 yd<sup>3</sup>) GP bucket. With Fusion coupler hooks. Requires: Edge group 100-6669, or adapter group 229-6942, tip group 217-4896 (8×) and segment group 100-6667 to be ordered separately.

**388-1946, 378-9993, 379-0000, 336-4973 or 379-0014 FORK, PALLET (QC)** Standard Fusion pallet fork. Which tine length is to be decided by the customer.

**Generator Set**

- The Caterpillar Mining Power Module is a self contained power plant with on board diesel fuel tank for up to 8 hours of operation, built to ISO 12.2 m (40 ft) dimensions for ease of shipping.

# HYDRAULIC EXCAVATORS

## Front Shovels

### Hydraulic Excavators

#### CONTENTS

##### FRONT SHOVELS

Specifications . . . . .	7-3
Digging Envelopes . . . . .	7-4
General Dimensions . . . . .	7-5

**HYDRAULIC EXCAVATORS**

Specifications . . . . .	7-8	Equipping Excavators:	
Shipping Dimensions . . . . .	7-41	Long Reach . . . . .	7-209
Major Component Weights . . . . .	7-76	Long Reach Excavation . . . . .	7-211
Range Dimensions:		Super Long Reach . . . . .	7-214
One-piece Boom . . . . .	7-96	Short Reach . . . . .	7-216
Hydraulically Adjustable Boom . . . . .	7-117	Machine Selection (tracks vs. wheels) . . . . .	7-218
Lifting Capacity (definition) . . . . .	7-122	Shoe Selection and Ground Pressure . . . . .	7-219
Lifting Capacity at Ground Level (charts) . . . . .	7-124	Quick Coupler Systems . . . . .	7-224
Buckets . . . . .	7-176	Ripping & Loading in Quarries . . . . .	7-230
Bucket Capacity (definition) . . . . .	7-185	Major Attachment Summary . . . . .	7-233
Curl and Crowd Forces . . . . .	7-185	Work Tools . . . . .	7-245
Bucket Specifications . . . . .	7-197	Cycle Time Estimating Charts . . . . .	7-246
New Nomenclature for		Machine Operation . . . . .	7-249
Hydraulic Excavator Buckets . . . . .	7-199	Maximizing Production	
Bucket Types . . . . .	7-201	with a Mass Excavator . . . . .	7-249
Bucket Sales Support . . . . .	7-205	Selecting a Mass Excavator . . . . .	7-250
Working Weights (bucket & payload) . . . . .	7-206	Earthmoving Production . . . . .	7-252
		Production Estimating Tables . . . . .	7-254
		Trenching Production . . . . .	7-256

# FRONT SHOVELS

## CONTENTS

### FRONT SHOVELS

Specifications . . . . .	7-3
Digging Envelopes . . . . .	7-4
General Dimensions . . . . .	7-5

MODEL	385C FS	
Region Offerings	<b>CIS, Europe, South America, Asia Pacific</b>	
Engine Power — ISO 9249	390 kW	530 hp
Operating Weight*	90 080-91 700 kg	198,592-202,164 lb
Bucket Capacity Range (heaped)	5.7 m <sup>3</sup>	7.4 yd <sup>3</sup>
Engine Model	<b>C18 ACERT™</b>	
Rated Engine RPM	<b>1800</b>	
No. of Cylinders	<b>6</b>	
Displacement	18.1 L	1105 in <sup>3</sup>
Max. Hydraulic Pump Output at Rated RPM	2 × 490 L/min	2 × 129 gpm
Relief Valve Settings:		
Implement Circuits	32 000 kPa	4640 psi
Swing	35 000 kPa	5075 psi
Travel Circuits	26 000 kPa	3770 psi
Pilot Circuits	4100 kPa	595 psi
Maximum Drawbar Pull	592 kN	133,200 lb
Maximum Travel Speed at Rated RPM	<b>Two Speed</b>	
Low	2.8 km/h	1.7 mph
High	4.5 km/h	2.8 mph
Overall Track Length**	5.84 m	19'2"
Track Gauge	2.75 m	9'0"
Extended	3.51 m	11'6"
Track Shoe Widths	650 mm	26"
Ground Contact Area with Standard Shoe	6.54 m <sup>2</sup>	70.4 ft <sup>2</sup>
Ground Pressures	138 kPa	20.0 psi
Fuel Tank Refill Capacity	1240 L	328 U.S. gal
Hydraulic System (includes tank)	995 L	263 U.S. gal
Hydraulic System	810 L	214 U.S. gal

\*Operating weight includes counterweight and full fuel.

\*\*Track length measured from center of idler to center of sprocket.

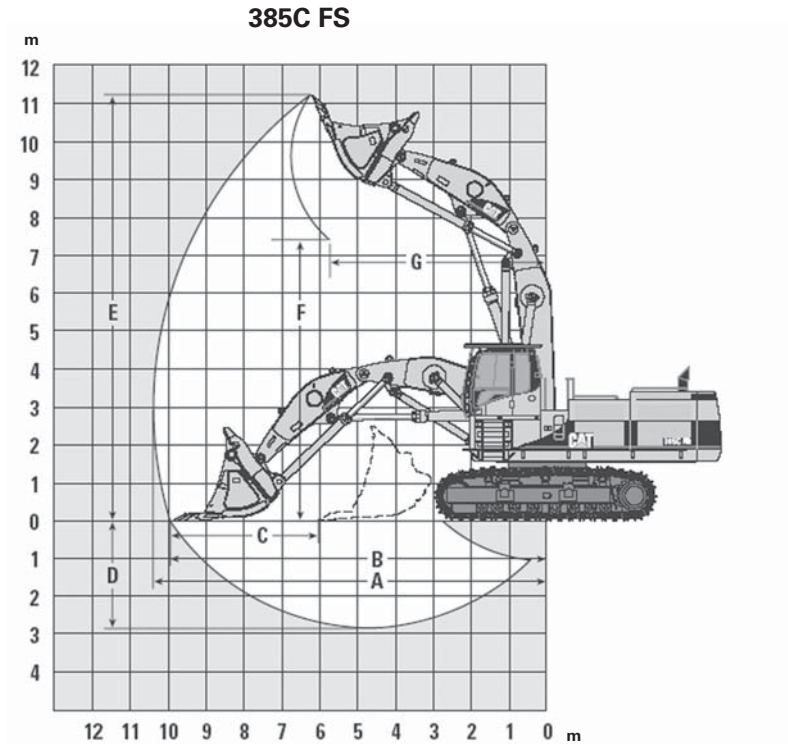

**385C FS**

Stick Length	3480 mm	11'5"
Boom Length	4600 mm	15'1"
Rock Bucket	5.2 m	17'1"
<b>A</b> Maximum Reach	10 350 mm	33'11"
<b>B</b> Maximum Reach at Ground Level	9900 mm	32'6"
<b>C</b> Maximum Level Crowd Distance	3920 mm	12'10"
<b>D</b> Maximum Digging Depth	2840 mm	9'4"
<b>E</b> Maximum Digging Height	11 260 mm	36'11"
<b>F</b> Maximum Dump Height	7430 mm	24'5"
<b>G</b> Reach at Maximum Dump Height	5690 mm	18'8"
Bucket Breakout Force (ISO)	538 kN	121,050 lb
Stick Breakout Force (ISO)	429 kN	96,530 lb

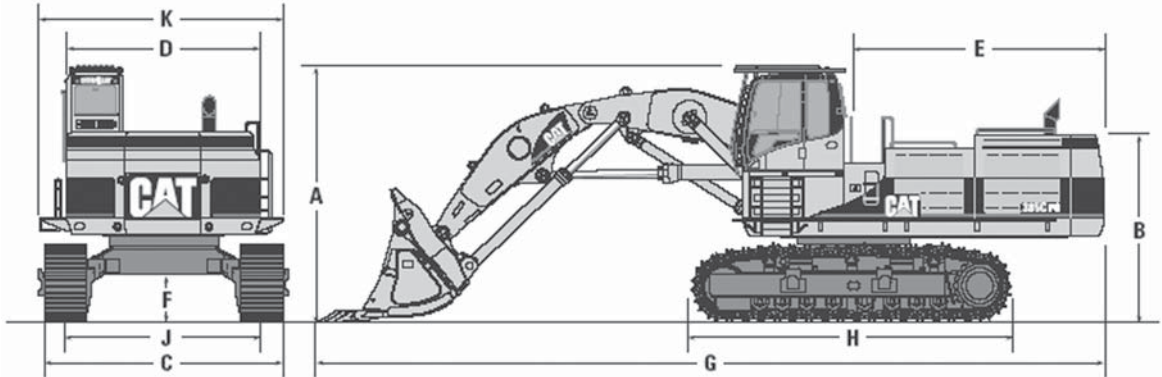

**385C FS**

Boom	4600 mm	15'1"
Stick	3480 mm	11'5"
<b>A</b> Boom Top Height	4500 mm	14'9"
Cab Top Height with FOPS	4660 mm	15'3"
Cab Top Height without FOPS	4520 mm	14'10"
<b>B</b> Engine Hood Height without Handrail	3460 mm	11'4"
<b>C</b> Overall Width		
650 mm (26") Shoes (retracted)	3400 mm	11'2"
750 mm (30") Shoes (retracted)	3500 mm	11'6"
650 mm (26") Shoes (extended)	4160 mm	13'8"
750 mm (30") Shoes (extended)	4260 mm	14'0"
<b>D</b> Upperstructure Width	3470 mm	11'5"
<b>E</b> Tail swing Radius	4590 mm	15'1"
<b>F</b> Minimum Ground Clearance	850 mm	2'9"
<b>G</b> Overall Length	14 250 mm	46'9"
<b>H</b> Track Length	5840 mm	19'2"
<b>J</b> Track Gauge Width		
Extended Position	3510 mm	11'6"
Retracted Position	2750 mm	9'0"



# HYDRAULIC EXCAVATORS

## CONTENTS

### HYDRAULIC EXCAVATORS

Specifications . . . . .	7-8	Equipping Excavators:	
Shipping Dimensions . . . . .	7-41	Long Reach . . . . .	7-209
Major Component Weights . . . . .	7-76	Long Reach Excavation . . . . .	7-211
Range Dimensions:		Super Long Reach . . . . .	7-214
One-piece Boom . . . . .	7-96	Short Reach . . . . .	7-216
Hydraulically Adjustable Boom . . . . .	7-117	Machine Selection (tracks vs. wheels) . . . . .	7-218
Lifting Capacity (definition) . . . . .	7-122	Shoe Selection and Ground Pressure . . . . .	7-219
Lifting Capacity at Ground Level (charts) . . . . .	7-124	Quick Coupler Systems . . . . .	7-224
Buckets . . . . .	7-176	Ripping & Loading in Quarries . . . . .	7-230
Bucket Capacity (definition) . . . . .	7-185	Major Attachment Summary . . . . .	7-233
Curl and Crowd Forces . . . . .	7-185	Work Tools . . . . .	7-245
Bucket Specifications . . . . .	7-197	Cycle Time Estimating Charts . . . . .	7-246
New Nomenclature for		Machine Operation . . . . .	7-249
Hydraulic Excavator Buckets . . . . .	7-199	Maximizing Production	
Bucket Types . . . . .	7-201	with a Mass Excavator . . . . .	7-249
Bucket Sales Support . . . . .	7-205	Selecting a Mass Excavator . . . . .	7-250
Working Weights (bucket & payload) . . . . .	7-206	Earthmoving Production . . . . .	7-252
		Production Estimating Tables . . . . .	7-254
		Trenching Production . . . . .	7-256



<b>MODEL</b>	<b>300.9D</b>		<b>301.4C Fixed Undercarriage</b>		<b>301.4C Extending Undercarriage</b>	
Region Offerings	<b>North America, South America, Canada, Australia, New Zealand, Europe, Africa, Middle East</b>		<b>North America, Canada, Australia, New Zealand, Europe, Africa, Middle East</b>		<b>North America, Canada, Australia, New Zealand, Europe, Africa, Middle East</b>	
Flywheel Power	13.7 kW	<b>18.4 hp</b>	13.2 kW	<b>18 hp</b>	13.2 kW	<b>18 hp</b>
Operating Weight*	985 kg	<b>2170 lb</b>	1470 kg	<b>3241 lb</b>	1558 kg	<b>3435 lb</b>
Bucket Capacity Range (heaped)	0.014- 0.018 m <sup>3</sup>	<b>0.027- 0.023 yd<sup>3</sup></b>	0.018- 0.056 m <sup>3</sup>	<b>0.023- 0.073 yd<sup>3</sup></b>	0.018- 0.056 m <sup>3</sup>	<b>0.023- 0.073 yd<sup>3</sup></b>
Engine Model	<b>Yanmar 31NV70</b>		<b>Yanmar 3TNV76</b>		<b>Yanmar 3TNV76</b>	
Emission Standards	<b>U.S. EPA Tier 4 Final/ EU Stage IIIB</b>		<b>Tier 4 Final/Stage IIIB</b>		<b>Tier 4 Final/Stage IIIB</b>	
Rated Engine RPM	<b>2100</b>		<b>2200</b>		<b>2200</b>	
No. of Cylinders	<b>3</b>		<b>3</b>		<b>3</b>	
Bore	70 mm	<b>2.8"</b>	—	—	—	—
Stroke	74 mm	<b>2.9"</b>	—	—	—	—
Displacement	854 cm <sup>3</sup>	<b>52 in<sup>3</sup></b>	1116 cm <sup>3</sup>	<b>68.1 in<sup>3</sup></b>	1116 cm <sup>3</sup>	<b>68.1 in<sup>3</sup></b>
Relief Valve Settings:						
Implement Circuits	17 MPa	<b>2465 psi</b>	20 MPa	<b>2901 psi</b>	20 MPa	<b>2901 psi</b>
Travel Circuits	17 MPa	<b>2465 psi</b>	20 MPa	<b>2901 psi</b>	20 MPa	<b>2901 psi</b>
Swing Circuits	17 MPa	<b>2465 psi</b>	15 MPa	<b>2176 psi</b>	15 MPa	<b>2176 psi</b>
Maximum Travel Speed at Rated RPM	1.8 km/h	<b>1.12 mph</b>	2.5 km/h	<b>1.55 mph</b>	2.5 km/h	<b>1.55 mph</b>
Width of Standard Track Shoe	180 mm	<b>7"</b>	230 mm	<b>9"</b>	230 mm	<b>9"</b>
Overall Track Length	1220 mm	<b>4'0"</b>	1460 mm	<b>4'9"</b>	1460 mm	<b>4'9"</b>
Track Gauge	531-864 mm	<b>21-27"</b>	760 mm	<b>30"</b>	1070 mm	<b>42"</b>
Fuel Tank Refill Capacity	10 L	<b>2.64 U.S. gal</b>	24 L	<b>6.3 U.S. gal</b>	24 L	<b>6.3 U.S. gal</b>
Hydraulic System (includes tank)	14 L	<b>3.7 U.S. gal</b>	20 L	<b>5.3 U.S. gal</b>	20 L	<b>5.3 U.S. gal</b>

\*Operating weight includes coolant, lubricants, full fuel tank, cab, standard shoes, bucket, medium stick, and operator 75 kg (165 lb).

**NOTE:** Certain models may not be available in all Sales areas.

Specifications also vary by Sales area.  
Contact your Cat® dealer for details.

<b>MODEL</b>	<b>301.7D Fixed Undercarriage</b>		<b>301.7D Extending Undercarriage</b>		<b>301.7D CR Extending Undercarriage</b>	
Region Offerings	North America, South America, Canada, Australia, New Zealand, Europe, Africa, Middle East		North America, South America, Canada, Australia, New Zealand, Europe, Africa, Middle East		North America, Canada, Australia, New Zealand, Europe, Africa, Middle East	
Flywheel Power	13.2 kW	<b>18 hp</b>	13.2 kW	<b>18 hp</b>	13.2 kW	<b>18 hp</b>
Operating Weight*	1720 kg	<b>3792 lb</b>	1845 kg	<b>4068 lb</b>	1690 kg	<b>3726 lb</b>
With Additional Counterweight	—		—		1740 kg	<b>3836 lb</b>
Bucket Capacity Range (heaped)	0.018- 0.056 m <sup>3</sup>	<b>0.023- 0.073 yd<sup>3</sup></b>	0.018- 0.056 m <sup>3</sup>	<b>0.023- 0.073 yd<sup>3</sup></b>	0.018- 0.056 m <sup>3</sup>	<b>0.023- 0.073 yd<sup>3</sup></b>
Engine Model	<b>Yanmar 3TNV76</b>		<b>Yanmar 3TNV76</b>		<b>Yanmar 3TNV76</b>	
Emission Standards	<b>Tier 4 Final/Stage IIIB</b>		<b>Tier 4 Final/Stage IIIB</b>		<b>Tier 4 Final/Stage IIIB</b>	
Rated Engine RPM	<b>2200</b>		<b>2200</b>		<b>2200</b>	
No. of Cylinders	<b>3</b>		<b>3</b>		<b>3</b>	
Displacement	1116 cm <sup>3</sup>	<b>68.1 in<sup>3</sup></b>	1116 cm <sup>3</sup>	<b>68.1 in<sup>3</sup></b>	1116 cm <sup>3</sup>	<b>68.1 in<sup>3</sup></b>
Max. Implement Hydraulic Pump Output at Rated RPM	23.8 + 23.8 + 19 + 6.4 L/min	<b>6.29 + 6.29 + 5 + 1.7 gpm</b>	23.8 + 23.8 + 19 + 6.4 L/min	<b>6.29 + 6.29 + 5 + 1.7 gpm</b>	39.6 L/min	<b>10.5 gpm</b>
Relief Valve Settings:						
Implement Circuits	20 MPa	<b>2901 psi</b>	20 MPa	<b>2901 psi</b>	24 MPa	<b>3481 psi</b>
Travel Circuits	20 MPa	<b>2901 psi</b>	20 MPa	<b>2901 psi</b>	24 MPa	<b>3481 psi</b>
Swing Circuits	12.5 MPa	<b>1813 psi</b>	12.5 MPa	<b>1813 psi</b>	18 MPa	<b>2610 psi</b>
	<b>Two Speed Travel</b>		<b>Two Speed Travel</b>		<b>Two Speed Travel</b>	
Maximum Travel Speed at Rated RPM	Lo: 2.8 km/h	<b>1.74 mph</b>	Lo: 2.8 km/h	<b>1.74 mph</b>	Lo: 2.8 km/h	<b>1.74 mph</b>
	Hi: 5.6 km/h	<b>3.48 mph</b>	Hi: 5.6 km/h	<b>3.48 mph</b>	Hi: 5.6 km/h	<b>3.48 mph</b>
Width of Standard Track Shoe	230 mm	<b>9"</b>	230 mm	<b>9"</b>	230 mm	<b>9"</b>
Overall Track Length	1445 mm	<b>4'9"</b>	1605 mm	<b>5'3"</b>	1607 mm	<b>5'3"</b>
Track Gauge	760 mm	<b>30"</b>	1070 mm	<b>42"</b>	1070 mm	<b>42"</b>
Fuel Tank Refill Capacity	24 L	<b>6.3 U.S. gal</b>	24 L	<b>6.3 U.S. gal</b>	19 L	<b>5 U.S. gal</b>
Hydraulic System (includes tank)	21 L	<b>5.5 U.S. gal</b>	21 L	<b>5.5 U.S. gal</b>	20 L	<b>5.3 U.S. gal</b>

\*Operating weight includes coolant, lubricants, full fuel tank, cab, standard shoes, bucket, medium stick, and operator 75 kg (165 lb).

**NOTE:** Certain models may not be available in all Sales areas.

Specifications also vary by Sales area.  
Contact your Cat dealer for details.

MODEL	302.2D		302.4D		302.7D CR	
Region Offerings	Europe, Africa, Middle East		North America, South America, Canada, Australia, New Zealand, Europe, Africa, Middle East		North America, South America, Canada, Australia, New Zealand, Europe, Africa, Middle East	
Flywheel Power	13.2 kW	<b>18 hp</b>	13.2 kW	<b>18 hp</b>	15.2 kW	<b>20.7 hp</b>
Operating Weight*	2135 kg	<b>4707 lb</b>	2320 kg	<b>5115 lb</b>	2670 kg	<b>5885 lb</b>
Bucket Capacity Range (heaped)	0.035-0.092 m <sup>3</sup>	<b>0.046-0.12 yd<sup>3</sup></b>	0.035-0.092 m <sup>3</sup>	<b>0.046-0.12 yd<sup>3</sup></b>	0.035-0.092 m <sup>3</sup>	<b>0.046-0.12 yd<sup>3</sup></b>
Engine Model	Yanmar 3TNV76		Yanmar 3TNV76		Yanmar 3TNV76	
Emission Standards	Stage IIIB		Tier 4 Final/Stage IIIB		Tier 4 Final/Stage IIIB	
Rated Engine RPM	2200		2200		2200	
No. of Cylinders	3		3		3	
Displacement	1116 cm <sup>3</sup>	<b>68.1 in<sup>3</sup></b>	1116 cm <sup>3</sup>	<b>68.1 in<sup>3</sup></b>	1115 cm <sup>3</sup>	<b>68 in<sup>3</sup></b>
Max. Implement Hydraulic Pump Output at Rated RPM	23.8 + 19 + 6.4 L/min	<b>6.29 + 5 + 1.7 gpm</b>	26.1 + 19.4 + 6.4 L/min	<b>6.9 + 5.1 + 1.7 gpm</b>	2 x 30.5/21.2 + 7.2 L/min	<b>2 x 8.1/5.6 + 1.9 gpm</b>
Relief Valve Settings:						
Implement Circuits	30 L/min @ 170 bar	<b>8 gpm @ 2465 psi</b>	24 MPa	<b>3480 psi</b>	22.5 MPa	<b>3263 psi</b>
Travel Circuits	—	—	24 MPa	<b>3480 psi</b>	22.5 MPa	<b>3263 psi</b>
Swing Circuits	17 L/min @ 200 bar	<b>4.5 gpm @ 2900 psi</b>	15 MPa	<b>2176 psi</b>	20.6 MPa	<b>2987 psi</b>
	<b>Two Speed Travel</b>		<b>Two Speed Travel</b>		<b>Two Speed Travel</b>	
Maximum Travel Speed at Rated RPM	Lo: 2.8 km/h Hi: 5.6 km/h	<b>1.74 mph 3.48 mph</b>	Lo: 2.5 km/h Hi: 4.0 km/h	<b>1.55 mph 2.5 mph</b>	Lo: 2.1 km/h Hi: 3.8 km/h	<b>1.3 mph 2.4 mph</b>
Width of Standard Track Shoe	250 mm	<b>10"</b>	250 mm	<b>10"</b>	300 mm	<b>12"</b>
Overall Track Length	1710 mm	<b>5'7"</b>	1840 mm	<b>6'0"</b>	2006 mm	<b>79"</b>
Track Gauge:						
Standard Undercarriage	—	—	1150 mm	<b>44"</b>	1270 mm	<b>50"</b>
Variable Width Undercarriage	740-1050 mm	<b>2'5"-3'5"</b>	—	—	—	—
Fuel Tank Refill Capacity	24 L	<b>6.3 U.S. gal</b>	24 L	<b>6.3 U.S. gal</b>	35.2 L	<b>9.3 U.S. gal</b>
Hydraulic System (includes tank)	21 L	<b>5.5 U.S. gal</b>	21 L	<b>5.5 U.S. gal</b>	26.5 L	<b>7.0 U.S. gal</b>

\*Operating weight includes coolant, lubricants, full fuel tank, cab, standard shoes, bucket, medium stick, and operator 75 kg (165 lb).

**NOTE:** Certain models may not be available in all Sales areas.

Specifications also vary by Sales area.

Contact your Cat dealer for details.

MODEL	303E CR		303.5E CR		303.5E2 CR	
Region Offerings	North America, South America, Canada, Australia, New Zealand		North America, South America, Canada, Australia, New Zealand, Europe, Africa, Middle East		North America**, South America***, Canada***, Australia***, New Zealand***, Africa***, Middle East***	
Flywheel Power	17.5 kW	<b>23.5 hp</b>	23.6 kW	<b>31.6 hp</b>	17.5 kW	<b>23.5 hp</b>
Operating Weight*	3530 kg	<b>7782 lb</b>	3692 kg	<b>8139 lb</b>	3860 kg	<b>8511 lb</b>
Bucket Capacity Range (heaped)	0.05-0.20 m <sup>3</sup>	<b>0.06-0.26 yd<sup>3</sup></b>	0.05-0.16 m <sup>3</sup>	<b>0.06-0.21 yd<sup>3</sup></b>	0.05-0.16 m <sup>3</sup>	<b>0.06-0.21 yd<sup>3</sup></b>
Engine Model	<b>Cat® C1.3</b>		<b>Cat C1.8</b>		<b>Cat C1.7</b>	
Emission Standards	<b>Tier 4 Final/Stage IIIB</b>		<b>Tier 4 Interim/ Stage IIIB Equivalent</b>		<b>Tier 4 Final/Stage IIIB** OR Tier 4 Interim/ Stage IIIB Equivalent***</b>	
Rated Engine RPM	<b>2400</b>		<b>2400</b>		<b>2200</b>	
No. of Cylinders	<b>3</b>		<b>3</b>		<b>3</b>	
Bore	78 mm	<b>3.1"</b>	87 mm	<b>3.4"</b>	87 mm	<b>3.4"</b>
Stroke	88 mm	<b>3.5"</b>	102.4 mm	<b>4"</b>	92.4 mm	<b>3.6"</b>
Displacement	1.261 L	<b>77 in<sup>3</sup></b>	1.8 L	<b>110 in<sup>3</sup></b>	1.7 L	<b>104 in<sup>3</sup></b>
Max. Implement Hydraulic Pump Output at Rated RPM	87.6 L/min	<b>23.14 gpm</b>	87.6 L/min	<b>23.14 gpm</b>	100 L/min	<b>26.4 gpm</b>
Relief Valve Settings:						
Implement Circuits	24.5 MPa	<b>3553 psi</b>	24.5 MPa	<b>3553 psi</b>	24.5 MPa	<b>3553 psi</b>
Travel Circuits	24.5 MPa	<b>3553 psi</b>	24.5 MPa	<b>3553 psi</b>	24.5 MPa	<b>3553 psi</b>
Swing Circuits	18.1 MPa	<b>2625 psi</b>	18.1 MPa	<b>2625 psi</b>	21.6 MPa	<b>3132 psi</b>
Maximum Drawbar Pull	30.9 kN	<b>6947 lbf</b>	31.0 kN	<b>6969 lbf</b>	31.1 kN	<b>6992 lbf</b>
	<b>Two Speed Travel</b>		<b>Two Speed Travel</b>		<b>Two Speed Travel</b>	
Maximum Travel Speed at Rated RPM	Lo: 2.42 km/h	<b>1.5 mph</b>	Lo: 2.6 km/h	<b>1.6 mph</b>	Lo: 3.2 km/h	<b>2.0 mph</b>
	Hi: 4.51 km/h	<b>2.8 mph</b>	Hi: 4.6 km/h	<b>2.8 mph</b>	Hi: 4.6 km/h	<b>2.9 mph</b>
Width of Standard Track Shoe	300 mm	<b>12"</b>	300 mm	<b>12"</b>	300 mm	<b>1'0"</b>
Overall Track Length	2210 mm	<b>7'3"</b>	2220 mm	<b>7'3"</b>	2220 mm	<b>7'3"</b>
Ground Contact Area with Std. Shoe	1.1 m <sup>2</sup>	<b>1705 in<sup>2</sup></b>	1.19 m <sup>2</sup>	<b>1845 in<sup>2</sup></b>	1.19 m <sup>2</sup>	<b>1845 in<sup>2</sup></b>
Track Gauge	1250 mm	<b>48"</b>	1480 mm	<b>58"</b>	1480 mm	<b>58"</b>
Fuel Tank Refill Capacity	45 L	<b>11.9 U.S. gal</b>	46 L	<b>12.2 U.S. gal</b>	46 L	<b>12.2 U.S. gal</b>
Hydraulic System (includes tank)	65 L	<b>17.2 U.S. gal</b>	65 L	<b>17.2 U.S. gal</b>	65 L	<b>17.2 U.S. gal</b>

\*Operating weight includes coolant, lubricants, full fuel tank, cab, standard shoes, bucket, medium stick, and operator 75 kg (165 lb).

\*\*Meets Tier 4 Final/Stage IIIB emission standards.

\*\*\*Meets Tier 4 Interim/Stage IIIB Equivalent emission standards.

NOTE: Certain models may not be available in all Sales areas.

Specifications also vary by Sales area.  
Contact your Cat dealer for details.

MODEL	304E2 CR		304.5E2 XTC		305E2 CR	
Region Offerings	North America**, South America***, Canada***, Australia***, New Zealand***, Europe***, Africa***, Middle East***		North America, Canada, Europe		North America**, South America***, Canada***, Australia***, New Zealand***, Europe***, Africa***, Middle East***	
Flywheel Power	30.0 kW	<b>40.2 hp</b>	30.0 kW	<b>40.2 hp</b>	30.0 kW	<b>40.2 hp</b>
Operating Weight*	4050 kg	<b>8930 lb</b>	4050 kg	<b>8930 lb</b>	5140 kg	<b>11,334 lb</b>
Bucket Capacity Range (heaped)	0.05-0.16 m <sup>3</sup>	<b>0.06-0.21 yd<sup>3</sup></b>	0.05-0.16 m <sup>3</sup>	<b>0.06-0.21 yd<sup>3</sup></b>	0.05-0.28 m <sup>3</sup>	<b>0.07-0.37 yd<sup>3</sup></b>
Engine Model	<b>Cat C2.4</b>		<b>Cat C2.4</b>		<b>Cat C2.4</b>	
Emission Standards	<b>Tier 4 Final/Stage IIIB** OR Tier 4 Interim/ Stage IIIB Equivalent***</b>		<b>Tier 4 Final/Stage IIIB** OR Tier 4 Interim/ Stage IIIB Equivalent***</b>		<b>Tier 4 Final/Stage IIIB** OR Tier 4 Interim/ Stage IIIB Equivalent***</b>	
Rated Engine RPM	<b>2200</b>		<b>2200</b>		<b>2200</b>	
No. of Cylinders	<b>4</b>		<b>4</b>		<b>4</b>	
Bore	87 mm	<b>3.4"</b>	87 mm	<b>3.4"</b>	87 mm	<b>3.4"</b>
Stroke	102.4 mm	<b>4.0"</b>	102.4 mm	<b>4.0"</b>	102.4 mm	<b>4.0"</b>
Displacement	2.4 L	<b>146 in<sup>3</sup></b>	2.4 L	<b>146 in<sup>3</sup></b>	2.4 L	<b>146 in<sup>3</sup></b>
Max. Implement Hydraulic Pump Output at Rated RPM	100 L/min	<b>26.4 gpm</b>	100 L/min	<b>26.4 gpm</b>	150 L/min	<b>39.6 gpm</b>
Relief Valve Settings:						
Implement Circuits	24.5 MPa	<b>3553 psi</b>	24.5 MPa	<b>3553 psi</b>	24.5 MPa	<b>3553 psi</b>
Travel Circuits	24.5 MPa	<b>3553 psi</b>	24.5 MPa	<b>3553 psi</b>	24.5 MPa	<b>3553 psi</b>
Swing Circuits	21.6 MPa	<b>3132 psi</b>	21.6 MPa	<b>3132 psi</b>	21.6 MPa	<b>3132 psi</b>
Maximum Drawbar Pull	31.0 kN	<b>6969 lbf</b>	31.0 kN	<b>6969 lbf</b>	45.2 kN	<b>10,161 lbf</b>
	<b>Two Speed Travel</b>		<b>Two Speed Travel</b>		<b>Two Speed Travel</b>	
Maximum Travel Speed at Rated RPM	Lo: 3.3 km/h	<b>2.1 mph</b>	Lo: 3.1 km/h	<b>1.9 mph</b>	Lo: 2.8 km/h	<b>1.7 mph</b>
	Hi: 5.1 km/h	<b>3.2 mph</b>	Hi: 5.1 km/h	<b>3.2 mph</b>	Hi: 4.4 km/h	<b>2.7 mph</b>
Width of Standard Track Shoe	350 mm	<b>1'2"</b>	350 mm	<b>1'2"</b>	400 mm	<b>1'4"</b>
Overall Track Length	2220 mm	<b>7'3"</b>	2220 mm	<b>7'3"</b>	2580 mm	<b>8'6"</b>
Ground Contact Area with Std. Shoe	1.19 m <sup>2</sup>	<b>1845 in<sup>2</sup></b>	1.19 m <sup>2</sup>	<b>1845 in<sup>2</sup></b>	1.8 m <sup>2</sup>	<b>2796 in<sup>2</sup></b>
Track Gauge	1600 mm	<b>63"</b>	1580 mm	<b>62"</b>	1580 mm	<b>62"</b>
Fuel Tank Refill Capacity	46 L	<b>12.2 U.S. gal</b>	57 L	<b>15.1 U.S. gal</b>	63 L	<b>16.6 U.S. gal</b>
Hydraulic System (includes tank)	65 L	<b>17.2 U.S. gal</b>	58 L	<b>15.3 U.S. gal</b>	78 L	<b>20.6 U.S. gal</b>

\*Operating weight includes coolant, lubricants, full fuel tank, cab, standard shoes, bucket, medium stick, and operator 75 kg (165 lb).

\*\*Meets Tier 4 Final/Stage IIIB emission standards.

\*\*\*Meets Tier 4 Interim/Stage IIIB Equivalent emission standards.

**NOTE:** Certain models may not be available in all Sales areas.

Specifications also vary by Sales area.

Contact your Cat dealer for details.

MODEL	305.5E2 CR		307E2	
Region Offerings	North America**, South America**, Canada**, Australia**, New Zealand**, Europe**, Africa**, Middle East**		North America, Canada, Europe	
Flywheel Power	32.9 kW	44.1 hp	37.7 kW	50.6 hp
Operating Weight*				
with Standard Counterweight	5380 kg	11,863 lb	7270 kg	16,030 lb
with Additional Counterweight	5545 kg	12,227 lb	—	—
Bucket Capacity Range (heaped)	0.05-0.28 m <sup>3</sup>	0.07-0.37 yd <sup>3</sup>	0.1-0.37 m <sup>3</sup>	0.13-0.48 yd <sup>3</sup>
Engine Model	Cat C2.4		Cat C2.4	
Emission Standards	Tier 4 Final/Stage IIIB** OR Tier 4 Interim/Stage IIIB Equivalent***		Tier 4 Final/Stage IIIB	
Rated Engine RPM	2400		2200	
No. of Cylinders	4		4	
Bore	87 mm	3.4"	87 mm	3.4"
Stroke	102.4 mm	4.0"	102.4 mm	4.0"
Displacement	2.4 L	146 in <sup>3</sup>	2.4 L	146 in <sup>3</sup>
Max. Implement Hydraulic Pump Output at Rated RPM	150 L/min	39.6 gpm	154 L/min	40.9 gpm
Relief Valve Settings:				
Implement Circuits	24.5 MPa	3553 psi	28 MPa	4061 psi
Travel Circuits	24.5 MPa	3553 psi	28 MPa	4061 psi
Swing Circuits	21.6 MPa	3132 psi	28 MPa	4061 psi
Maximum Drawbar Pull	47.8 kN	10,746 lbf	59.3 kN	13,331 lbf
	Two Speed Travel		Two Speed Travel	
Maximum Travel Speed at Rated RPM	Lo: 2.8 km/h	1.7 mph	Lo: 3.2 km/h	2.0 mph
	Hi: 4.4 km/h	2.7 mph	Hi: 5.1 km/h	3.2 mph
Width of Standard Track Shoe	400 mm	1'4"	450 mm	1'6"
Overall Track Length	2580 mm	8'6"	2760 mm	9'1"
Ground Contact Area with Std. Shoe	1.8 m <sup>2</sup>	2796 in <sup>2</sup>	2.11 m <sup>2</sup>	3270 in <sup>2</sup>
Track Gauge	1580 mm	62"	1750 mm	69"
Fuel Tank Refill Capacity	63 L	16.6 U.S. gal	135 L	35.7 U.S. gal
Hydraulic System (includes tank)	78 L	20.6 U.S. gal	78 L	20.6 U.S. gal

\*Operating weight includes coolant, lubricants, full fuel tank, cab, standard shoes, bucket, medium stick, and operator 75 kg (165 lb).

\*\*Meets Tier 4 Final/Stage IIIB emission standards.

\*\*\*Meets Tier 4 Interim/Stage IIIB Equivalent emission standards.

NOTE: Certain models may not be available in all Sales areas.

Specifications also vary by Sales area.

Contact your Cat dealer for details.

<b>MODEL</b>	<b>308E2 CR SB</b>		<b>308 E2 VAB</b>	
Region Offerings	<b>North America, Canada, Australia, New Zealand, Europe</b>		<b>North America, Canada, Europe</b>	
Flywheel Power	48.5 kW	<b>65 hp</b>	48.5 kW	<b>65 hp</b>
Operating Weight*				
with Standard Counterweight	8400 kg	<b>18,522 lb</b>	8700 kg	<b>19,184 lb</b>
with Additional Counterweight	8650 kg	<b>19,073 lb</b>	—	
Bucket Capacity Range (heaped)	0.1-0.37 m <sup>3</sup>	<b>0.13-0.48 yd<sup>3</sup></b>	0.1-0.37 m <sup>3</sup>	<b>0.13-0.48 yd<sup>3</sup></b>
Engine Model	<b>Cat C3.3B</b>		<b>Cat C3.3B</b>	
Emission Standards	<b>Tier 4 Final/Stage IIIB</b>		<b>Tier 4 Final/Stage IIIB</b>	
Rated Engine RPM	<b>2400</b>		<b>2400</b>	
No. of Cylinders	<b>4</b>		<b>4</b>	
Bore	94 mm	<b>3.7"</b>	94 mm	<b>3.7"</b>
Stroke	120 mm	<b>4.7"</b>	120 mm	<b>4.7"</b>
Displacement	3.3 L	<b>203 in<sup>3</sup></b>	3.3 L	<b>203 in<sup>3</sup></b>
Max. Implement Hydraulic Pump Output at Rated RPM	150 L/min	<b>39.6 gpm</b>	150 L/min	<b>39.6 gpm</b>
Relief Valve Settings:				
Implement Circuits	28 MPa	<b>4061 psi</b>	28 MPa	<b>4061 psi</b>
Travel Circuits	28 MPa	<b>4061 psi</b>	28 MPa	<b>4061 psi</b>
Swing Circuits	28 MPa	<b>4061 psi</b>	28 MPa	<b>4061 psi</b>
Maximum Drawbar Pull	66.1 kN	<b>14,860 lbf</b>	66.1 kN	<b>14,860 lbf</b>
	<b>Two Speed Travel</b>		<b>Two Speed Travel</b>	
Maximum Travel Speed at Rated RPM	Lo: 3.3 km/h	<b>2.1 mph</b>	Lo: 3.3 km/h	<b>2.1 mph</b>
	Hi: 5.3 km/h	<b>3.3 mph</b>	Hi: 5.3 km/h	<b>3.3 mph</b>
Width of Standard Track Shoe	450 mm	<b>1'6"</b>	450 mm	<b>1'6"</b>
Overall Track Length	2903 mm	<b>9'6"</b>	2903 mm	<b>9'6"</b>
Ground Contact Area with Std. Shoe	3 m <sup>2</sup>	<b>4650 in<sup>2</sup></b>	3 m <sup>2</sup>	<b>4650 in<sup>2</sup></b>
Track Gauge	1870 mm	<b>73"</b>	1870 mm	<b>73"</b>
Fuel Tank Refill Capacity	125 L	<b>33 U.S. gal</b>	125 L	<b>33 U.S. gal</b>
Hydraulic System (includes tank)	94 L	<b>24.8 U.S. gal</b>	94 L	<b>24.8 U.S. gal</b>

\*Operating weight includes coolant, lubricants, full fuel tank, cab, standard shoes, bucket, medium stick, and operator 75 kg (165 lb).

**NOTE:** Certain models may not be available in all Sales areas.

Specifications also vary by Sales area.

Contact your Cat dealer for details.

MODEL	311F L RR		312D2		312D2 GC	
Region Offerings	North America, Europe, Australia, New Zealand and Polynesia, Japan		Asia Pacific		China	
Engine Power:						
ISO 9249	52 kW	70 hp	67 kW	90 hp	56 kW	75 hp
SAE J1349	52 kW	70 hp	67 kW	90 hp	56 kW	75 hp
Operating Weight*	12 400-13 900 kg	27,300-30,600 lb	12 900-13 600 kg	28,440-29,980 lb	12 500 kg	27,560 lb
Bucket Capacity Range (heaped)	0.20-0.76 m <sup>3</sup>	0.27-1.0 yd <sup>3</sup>	0.31-0.76 m <sup>3</sup>	0.4-1.0 yd <sup>3</sup>	0.53 m <sup>3</sup>	0.69 yd <sup>3</sup>
Engine Model	C3.4B		3054C		3054C	
Emission Standards	Tier 4 Final/Stage IIIB/Japan 2014 (Tier 4 Final)		Tier 2/Stage II Equivalent		China Nonroad Stage II Equivalent	
Rated Engine RPM	1800		1800		1800	
No. of Cylinders	4		4		4	
Bore	99 mm	3.90"	105 mm	4.13"	105 mm	4.13"
Stroke	110 mm	4.33"	127 mm	5.00"	127 mm	5.00"
Displacement	3.4 L	207 in <sup>3</sup>	4.4 L	269 in <sup>3</sup>	4.4 L	269 in <sup>3</sup>
Max. Implement Hydraulic Pump Output at Rated RPM	2 × 125 L/min	2 × 33 gpm	2 × 127 L/min	2 × 34 gpm	2 × 127 L/min	2 × 34 gpm
Relief Valve Settings:						
Implement Circuits	30 500 kPa	4424 psi	30 500 kPa	4424 psi	30 500 kPa	4424 psi
Travel Circuits	35 000 kPa	5076 psi	35 000 kPa	5080 psi	35 000 kPa	5076 psi
Swing Circuits	23 000 kPa	3336 psi	23 000 kPa	3340 psi	23 000 kPa	3336 psi
Pilot Circuits	4120 kPa	598 psi	4100 kPa	600 psi	4120 kPa	598 psi
Maximum Drawbar Pull	114.3 kN	25,696 lb	114 kN	25,630 lbf	114 kN	25,628 lbf
	<b>Two Speed Travel</b>		<b>Two Speed Travel</b>		<b>Two Speed Travel</b>	
Maximum Travel Speed at Rated RPM	Lo: 3.6 km/h	2.2 mph	Lo: 3.8 km/h	2.4 mph	Lo: 3.5 km/h	2.2 mph
	Hi: 5.4 km/h	3.4 mph	Hi: 5.6 km/h	3.5 mph	Hi: 5.1 km/h	3.2 mph
Width of Standard Track Shoe	500 mm	1'8"	500 mm	1'8"	500 mm	20"
Overall Track Length	3490 mm	11'5"	3490 mm	11'5"	3490 mm	11'5"
Ground Contact Area with Std. Shoe	3.03 m <sup>2</sup>	4700 in <sup>2</sup>	3.03 m <sup>2</sup>	4700 in <sup>2</sup>	3.03 m <sup>2</sup>	4700 in <sup>2</sup>
Track Gauge	1990 mm	6'6"	1990 mm	6'6"	1990 mm	6'6"
Fuel Tank Refill Capacity	210 L	55.5 U.S. gal	250 L	66 U.S. gal	250 L	66 U.S. gal
Hydraulic System (includes tank)	160 L	42.3 U.S. gal	104 L	27.5 U.S. gal	150 L	39.6 U.S. gal

\*Operating weight includes coolant, lubricants, full fuel tank, cab, standard shoes, bucket, medium stick, and operator 75 kg (165 lb).

NOTE: Certain models may not be available in all Sales areas.

Specifications also vary by Sales area.

Contact your Cat dealer for details.



MODEL	312D2 L		312E		312E L	
Region Offerings	<b>Middle East, Africa, CIS, Asia Pacific, South America</b>		<b>Europe, Australia, New Zealand and Polynesia, Japan</b>		<b>North America, Europe, Australia, New Zealand and Polynesia</b>	
Engine Power:						
ISO 9249	67 kW	<b>90 hp</b>	68 kW	<b>91 hp</b>	68 kW	<b>91 hp</b>
SAE J1349	<b>N/A</b>		68 kW	<b>91 hp</b>	68 kW	<b>91 hp</b>
Operating Weight*	13 200- 13 900 kg	<b>29,100- 30,640 lb</b>	13 200- 15 700 kg	<b>29,100- 34,620 lb</b>	13 200- 15 700 kg	<b>29,100- 34,620 lb</b>
Bucket Capacity Range (heaped)	0.31-0.76 m <sup>3</sup>	<b>0.4-1.0 yd<sup>3</sup></b>	0.20-0.76 m <sup>3</sup>	<b>0.27-0.99 yd<sup>3</sup></b>	0.20-0.76 m <sup>3</sup>	<b>0.27-1.0 yd<sup>3</sup></b>
Engine Model	<b>3054C</b>		<b>C4.4 ACERT</b>		<b>C4.4 ACERT</b>	
Emission Standards	<b>Tier 2/Stage II Equivalent</b>		<b>Tier 4 Interim/Stage IIIB/ Japan 2011 (Tier 4 Interim) Equivalent</b>		<b>Tier 4 Interim/ Stage IIIB Equivalent</b>	
Rated Engine RPM	<b>2200</b>		<b>1800</b>		<b>1800</b>	
No. of Cylinders	<b>4</b>		<b>4</b>		<b>4</b>	
Bore	105 mm	<b>4.13"</b>	105 mm	<b>4.13"</b>	105 mm	<b>4.13"</b>
Stroke	127 mm	<b>5.00"</b>	127 mm	<b>5.00"</b>	127 mm	<b>5.00"</b>
Displacement	4.4 L	<b>269 in<sup>3</sup></b>	4.4 L	<b>269 in<sup>3</sup></b>	4.4 L	<b>269 in<sup>3</sup></b>
Max. Implement Hydraulic Pump Output at Rated RPM	2 x 127 L/min	<b>2 x 34 gpm</b>	2 x 127 L/min	<b>2 x 34 gpm</b>	2 x 127 L/min	<b>2 x 34 gpm</b>
Relief Valve Settings:						
Implement Circuits	30 500 kPa	<b>4424 psi</b>	30 500 kPa	<b>4424 psi</b>	30 500 kPa	<b>4424 psi</b>
Travel Circuits	35 000 kPa	<b>5080 psi</b>	35 000 kPa	<b>5076 psi</b>	35 000 kPa	<b>5076 psi</b>
Swing Circuits	23 000 kPa	<b>3340 psi</b>	23 000 kPa	<b>3336 psi</b>	23 000 kPa	<b>3336 psi</b>
Pilot Circuits	4100 kPa	<b>600 psi</b>	4120 kPa	<b>598 psi</b>	4120 kPa	<b>598 psi</b>
Maximum Drawbar Pull	114 kN	<b>25,630 lbf</b>	114 kN	<b>25,628 lbf</b>	114 kN	<b>25,628 lbf</b>
	<b>Two Speed Travel</b>					
Maximum Travel Speed at Rated RPM	Lo: 3.8 km/h	<b>2.4 mph</b>	5.5 km/h	<b>3.4 mph</b>	5.5 km/h	<b>3.4 mph</b>
	Hi: 5.6 km/h	<b>3.5 mph</b>				
Width of Standard Track Shoe	500 mm	<b>1'8"</b>	700 mm	<b>28"</b>	700 mm	<b>28"</b>
Overall Track Length	3750 mm	<b>12'4"</b>	3750 mm	<b>12'4"</b>	3750 mm	<b>12'4"</b>
Ground Contact Area with Std. Shoe	3.29 m <sup>2</sup>	<b>5100 in<sup>2</sup></b>	4.2 m <sup>2</sup>	<b>6600 in<sup>2</sup></b>	4.6 m <sup>2</sup>	<b>7150 in<sup>2</sup></b>
Track Gauge	1990 mm	<b>6'6"</b>	1990 mm	<b>6'6"</b>	1990 mm	<b>6'6"</b>
Fuel Tank Refill Capacity	250 L	<b>66 U.S. gal</b>	250 L	<b>66.04 U.S. gal</b>	250 L	<b>66.04 U.S. gal</b>
Hydraulic System (includes tank)	104 L	<b>27.5 U.S. gal</b>	162 L	<b>42.8 U.S. gal</b>	162 L	<b>42.8 U.S. gal</b>

\*Operating weight includes coolant, lubricants, full fuel tank, standard shoes, bucket, medium stick, and operator 75 kg (165 lb).

**NOTE:** Certain models may not be available in all Sales areas.

Specifications also vary by Sales area.

Contact your Cat dealer for details.

MODEL	312F GC		313D2		313D2 LGP	
Region Offerings	Japan		China, Asia Pacific		Asia Pacific	
Engine Power:						
ISO 9249	55 kW	<b>74 hp</b>	67 kW	<b>90 hp</b>	67 kW	<b>90 hp</b>
SAE J1349	54 kW	<b>72 hp</b>	67 kW	<b>90 hp</b>	67 kW	<b>90 hp</b>
Operating Weight*	12 500- 13 900 kg	<b>27,600- 30,600 lb</b>	13 400 kg	<b>29,550 lb</b>	16 000 kg	<b>35,300 lb</b>
Bucket Capacity Range (heaped)	0.20-0.76 m <sup>3</sup>	<b>0.27-1.0 yd<sup>3</sup></b>	0.65 m <sup>3</sup>	<b>0.85 yd<sup>3</sup></b>	0.65 m <sup>3</sup>	<b>0.84 yd<sup>3</sup></b>
Engine Model	<b>C3.4B</b>		<b>3054C</b>		<b>3054C</b>	
Emission Standards	<b>Tier 4 Final/Stage IIIB/ Japan 2014 (Tier 4 Final)</b>		<b>China Nonroad Stage II Equivalent</b>		<b>Tier 2/Stage II Equivalent</b>	
Rated Engine RPM	<b>1700</b>		<b>1800</b>		<b>1800</b>	
No. of Cylinders	<b>4</b>		<b>4</b>		<b>4</b>	
Bore	99 mm	<b>3.9"</b>	105 mm	<b>4.13"</b>	105 mm	<b>4.13"</b>
Stroke	110 mm	<b>4.33"</b>	127 mm	<b>5.00"</b>	127 mm	<b>5.00"</b>
Displacement	3.4 L	<b>207 in<sup>3</sup></b>	4.4 L	<b>269 in<sup>3</sup></b>	4.4 L	<b>269 in<sup>3</sup></b>
Max. Implement Hydraulic Pump Output at Rated RPM	2 x 127 L/min	<b>2 x 33.6 gpm</b>	2 x 127 L/min	<b>2 x 34 gpm</b>	2 x 127 L/min	<b>2 x 34 gpm</b>
Relief Valve Settings:						
Implement Circuits	30 500 kPa	<b>5076 psi</b>	30 500 kPa	<b>4424 psi</b>	30.5 MPa	<b>4430 psi</b>
Travel Circuits	35 000 kPa	<b>5076 psi</b>	35 000 kPa	<b>5076 psi</b>	35 MPa	<b>5080 psi</b>
Swing Circuits	23 000 kPa	<b>3336 psi</b>	23 000 kPa	<b>3336 psi</b>	23 MPa	<b>3340 psi</b>
Pilot Circuits	4120 kPa	<b>598 psi</b>	4120 kPa	<b>598 psi</b>	4120 kPa	<b>598 psi</b>
Maximum Drawbar Pull	109.9 kN	<b>24,706 lb</b>	114 kN	<b>25,628 lbf</b>	156 kN	<b>34,980 lbf</b>
	<b>Two Speed Travel</b>		<b>Two Speed Travel</b>		<b>Two Speed Travel</b>	
Maximum Travel Speed at Rated RPM	Lo: 3.6 km/h	<b>2.2 mph</b>	Lo: 3.8 km/h	<b>2.4 mph</b>	Lo: 2.8 km/h	<b>1.7 mph</b>
	Hi: 5.5 km/h	<b>3.4 mph</b>	Hi: 5.6 km/h	<b>3.5 mph</b>	Hi: 4.6 km/h	<b>2.9 mph</b>
Width of Standard Track Shoe	500 mm	<b>1'8"</b>	500 mm	<b>1'11"</b>	960 mm	<b>3'2"</b>
Overall Track Length	3490 mm	<b>11'5"</b>	3490 mm	<b>11'5"</b>	4020 mm	<b>13'2"</b>
Ground Contact Area with Std. Shoe	3.03 m <sup>2</sup>	<b>4700 in<sup>2</sup></b>	3.03 m <sup>2</sup>	<b>4700 in<sup>2</sup></b>	6.6 m <sup>2</sup>	<b>10,230 in<sup>2</sup></b>
Track Gauge	1990 mm	<b>6'6"</b>	1990 mm	<b>6'6"</b>	2080 mm	<b>6'10"</b>
Fuel Tank Refill Capacity	250 L	<b>66 U.S. gal</b>	250 L	<b>66 U.S. gal</b>	250 L	<b>66 U.S. gal</b>
Hydraulic System (includes tank)	164 L	<b>43.3 U.S. gal</b>	104 L	<b>27.5 U.S. gal</b>	164 L	<b>43.32 U.S. gal</b>

\*Operating weight includes coolant, lubricants, full fuel tank, standard shoes, bucket, medium stick, and operator 75 kg (165 lb).

**NOTE:** Certain models may not be available in all Sales areas.

Specifications also vary by Sales area.

Contact your Cat dealer for details.

MODEL	313F L GC		314E CR		314E LCR	
Region Offerings	North America, Europe, Turkey		Australia, New Zealand and Polynesia, Japan		North America, Europe, Australia, New Zealand and Polynesia, Japan	
Engine Power:						
ISO 9249	55 kW	<b>74 hp</b>	67 kW	<b>89 hp</b>	67 kW	<b>89 hp</b>
SAE J1349	54 kW	<b>72 hp</b>	67 kW	<b>89 hp</b>	67 kW	<b>89 hp</b>
Operating Weight*	13 200-14 600 kg	<b>29,100-32,200 lb</b>	13 300-15 200 kg	<b>29,300-33,500 lb</b>	14 500-17 100 kg	<b>31,970-37,710 lb</b>
Bucket Capacity Range (heaped)	0.20-0.76 m <sup>3</sup>	<b>0.27-1.0 yd<sup>3</sup></b>	0.20-0.76 m <sup>3</sup>	<b>0.76-1.00 yd<sup>3</sup></b>	0.20-0.76 m <sup>3</sup>	<b>0.76-1.00 yd<sup>3</sup></b>
Engine Model	<b>C3.4B</b>		<b>C4.4 ACERT</b>		<b>C4.4 ACERT</b>	
Emission Standards	<b>Tier 4 Final/Stage IIIB/ Japan 2014 (Tier 4 Final)</b>		<b>Tier 4 Interim/Stage IIIB/ Japan 2011 (Tier 4 Interim) Equivalent</b>		<b>Tier 4 Interim/Stage IIIB/ Japan 2011 (Tier 4 Interim) Equivalent</b>	
Rated Engine RPM	<b>1700</b>		<b>1800</b>		<b>1800</b>	
No. of Cylinders	<b>4</b>		<b>4</b>		<b>4</b>	
Bore	99 mm	<b>3.9"</b>	105 mm	<b>4.1"</b>	105 mm	<b>4.1"</b>
Stroke	110 mm	<b>4.33"</b>	127 mm	<b>5.00"</b>	127 mm	<b>5.00"</b>
Displacement	3.4 L	<b>207 in<sup>3</sup></b>	4.4 L	<b>270 in<sup>3</sup></b>	4.4 L	<b>270 in<sup>3</sup></b>
Max. Implement Hydraulic Pump Output at Rated RPM	2 x 127 L/min	<b>2 x 33.6 gpm</b>	2 x 119 L/min	<b>2 x 32 gpm</b>	2 x 127 L/min	<b>2 x 34 gpm</b>
Relief Valve Settings:						
Implement Circuits	30 500 kPa	<b>5076 psi</b>	30 500 kPa	<b>4420 psi</b>	30 500 kPa	<b>4420 psi</b>
Travel Circuits	35 000 kPa	<b>5076 psi</b>	35 000 kPa	<b>5080 psi</b>	35 000 kPa	<b>5080 psi</b>
Swing Circuits	23 000 kPa	<b>3336 psi</b>	23 000 kPa	<b>3340 psi</b>	23 000 kPa	<b>3340 psi</b>
Pilot Circuits	4120 kPa	<b>598 psi</b>	4120 kPa	<b>600 psi</b>	4120 kPa	<b>600 psi</b>
Maximum Drawbar Pull	109.9 kN	<b>24,706 lb</b>	113 kN	<b>25,400 lbf</b>	113 kN	<b>25,400 lbf</b>
	<b>Two Speed Travel</b>					
Maximum Travel Speed at Rated RPM	Lo: 3.6 km/h	<b>2.2 mph</b>	5.4 km/h	<b>3.4 mph</b>	5.4 km/h	<b>3.4 mph</b>
	Hi: 5.4 km/h	<b>3.4 mph</b>				
Width of Standard Track Shoe	500 mm	<b>1'8"</b>	500 mm	<b>1'11"</b>	500 mm	<b>1'11"</b>
Overall Track Length	3740 mm	<b>12'3"</b>	3490 mm	<b>11'5"</b>	3750 mm	<b>11'5"</b>
Ground Contact Area with Std. Shoe	3.03 m <sup>2</sup>	<b>4700 in<sup>2</sup></b>	3.03 m <sup>2</sup>	<b>4700 in<sup>2</sup></b>	3.29 m <sup>2</sup>	<b>5100 in<sup>2</sup></b>
Track Gauge	1990 mm	<b>6'6"</b>	1990 mm	<b>6'6"</b>	1990 mm	<b>6'6"</b>
Fuel Tank Refill Capacity	250 L	<b>66 U.S. gal</b>	178 L	<b>47 U.S. gal</b>	178 L	<b>47 U.S. gal</b>
Hydraulic System (includes tank)	164 L	<b>43.3 U.S. gal</b>	160 L	<b>42.3 U.S. gal</b>	162 L	<b>42.8 U.S. gal</b>

\*Operating weight includes coolant, lubricants, full fuel tank, standard shoes, bucket, medium stick, and operator 75 kg (165 lb).

**NOTE:** Certain models may not be available in all Sales areas.

Specifications also vary by Sales area.  
Contact your Cat dealer for details.

MODEL	316E L		318D2 L		318E L	
Region Offerings	North America, Europe, Australia, New Zealand and Polynesia, Japan		Middle East, Africa, CIS, South America, Asia Pacific, China		North America, Europe, Australia, New Zealand and Polynesia	
Engine Power:						
ISO 9249	85 kW	<b>113 hp</b>	82 kW	<b>110 hp</b>	85 kW	<b>113 hp</b>
SAE J1349	85 kW	<b>113 hp</b>	82 kW	<b>110 hp</b>	85 kW	<b>113 hp</b>
Operating Weight*	17 200- 18 700 kg	<b>37,920- 41,230 lb</b>	17 000- 17 800 kg	<b>37,490- 39,250 lb</b>	18 600-19 500 kg	<b>41,010- 43,000 lb</b>
Bucket Capacity Range (heaped)	0.35-1.09 m <sup>3</sup> <b>0.46-1.43 yd<sup>3</sup></b>		0.73-1.09 m <sup>3</sup> <b>0.96-1.43 yd<sup>3</sup></b>		0.35-0.91 m <sup>3</sup> <b>0.46-1.19 yd<sup>3</sup></b>	
Engine Model	<b>C4.4 ACERT</b>		<b>3054CA</b>		<b>C4.4 ACERT</b>	
Emission Standards	<b>Tier 4 Interim/Stage IIIB/ Japan 2011 (Tier 4 Interim) Equivalent</b>		<b>Tier 2/Stage II/ China Nonroad Stage II Equivalent</b>		<b>Tier 4 Interim/Stage IIIB Equivalent</b>	
Rated Engine RPM	<b>1950</b>		<b>1950</b>		<b>1950</b>	
No. of Cylinders	<b>4</b>		<b>4</b>		<b>4</b>	
Bore	105 mm	<b>4.13"</b>	105 mm	<b>4.13"</b>	105 mm	<b>4.13"</b>
Stroke	127 mm	<b>5.00"</b>	127 mm	<b>5.00"</b>	127 mm	<b>5.00"</b>
Displacement	4.4 L	<b>269 in<sup>3</sup></b>	4.4 L	<b>269 in<sup>3</sup></b>	4.4 L	<b>269 in<sup>3</sup></b>
Max. Implement Hydraulic Pump Output at Rated RPM	2 × 150 L/min	<b>2 × 40 gpm</b>	2 × 136 L/min	<b>2 × 36 gpm</b>	2 × 150 L/min	<b>2 × 40 gpm</b>
Relief Valve Settings:						
Implement Circuits	35 000 kPa	<b>5076 psi</b>	35 000 kPa	<b>5080 psi</b>	35 000 kPa	<b>5076 psi</b>
Travel Circuits	35 000 kPa	<b>5076 psi</b>	36 300 kPa	<b>5265 psi</b>	35 000 kPa	<b>5076 psi</b>
Swing Circuits	22 600 kPa	<b>3278 psi</b>	22 600 kPa	<b>3280 psi</b>	23 000 kPa	<b>3336 psi</b>
Pilot Circuits	4120 kPa	<b>598 psi</b>	4120 kPa	<b>600 psi</b>	4120 kPa	<b>598 psi</b>
Maximum Drawbar Pull	156.2 kN	<b>35,115 lbf</b>	156 kN	<b>35,070 lbf</b>	206.9 kN	<b>46,513 lbf</b>
Maximum Travel Speed at Rated RPM	5.2 km/h	<b>3.2 mph</b>	4.8 km/h	<b>3.0 mph</b>	3.9 km/h	<b>2.4 mph</b>
Width of Standard Track Shoe	700 mm	<b>28"</b>	600 mm	<b>24"</b>	600 mm	<b>24"</b>
Overall Track Length	3970 mm	<b>13'0"</b>	3970 mm	<b>13'0"</b>	4075 mm	<b>13'4"</b>
Ground Contact Area with Std. Shoe	4.8 m <sup>2</sup>	<b>6400 in<sup>2</sup></b>	4.1 m <sup>2</sup>	<b>6400 in<sup>2</sup></b>	4.3 m <sup>2</sup>	<b>6600 in<sup>2</sup></b>
Track Gauge	1990 mm	<b>6'6"</b>	1990 mm	<b>6'6"</b>	1990 mm	<b>6'6"</b>
Fuel Tank Refill Capacity	290 L	<b>76.61 U.S. gal</b>	300 L	<b>79.3 U.S. gal</b>	290 L	<b>79.61 U.S. gal</b>
Hydraulic System (includes tank)	190 L	<b>50.19 U.S. gal</b>	121 L	<b>32 U.S. gal</b>	190 L	<b>50.19 U.S. gal</b>

\*Operating weight includes coolant, lubricants, full fuel tank, cab, standard shoes, bucket, medium stick, and operator 75 kg (165 lb).

**NOTE:** Certain models may not be available in all Sales areas.

Specifications also vary by Sales area.

Contact your Cat dealer for details.

MODEL	M313D†		M313D†		M315D†	
Region Offerings	North America, Australia, New Zealand		Europe		North America, Australia, New Zealand	
Engine Power:						
ISO 9249	95 kW	<b>127 hp</b>	95 kW	<b>127 hp</b>	101 kW	<b>135 hp</b>
ISO 14396	102 kW	<b>137 hp</b>	102 kW	<b>137 hp</b>	108 kW	<b>145 hp</b>
Operating Weight*	14 000- 16 200 kg	<b>30,870- 35,721 lb</b>	14 000- 16 200 kg	<b>30,870- 35,721 lb</b>	16 100- 18 300 kg	<b>35,501- 40,352 lb</b>
Bucket Capacity Range (heaped)	0.18-0.92 m <sup>3</sup>	<b>0.24-1.2 yd<sup>3</sup></b>	0.18-0.92 m <sup>3</sup>	<b>0.24-1.2 yd<sup>3</sup></b>	0.38-1.26 m <sup>3</sup>	<b>0.5-1.65 yd<sup>3</sup></b>
Engine Model	<b>C4.4 ACERT</b>		<b>C4.4 ACERT</b>		<b>C4.4 ACERT</b>	
Emission Standards	<b>Tier 3/Stage IIIA/ UN/ECE R96 Stage IIIA</b>		<b>Stage IIIB</b>		<b>Tier 3/Stage IIIA/ UN/ECE R96 Stage IIIA</b>	
Rated Engine RPM	<b>2000</b>		<b>2000</b>		<b>2000</b>	
No. of Cylinders	<b>4</b>		<b>4</b>		<b>4</b>	
Bore	105 mm	<b>4.1"</b>	105 mm	<b>4.1"</b>	105 mm	<b>4.1"</b>
Stroke	127 mm	<b>5"</b>	127 mm	<b>5"</b>	127 mm	<b>5"</b>
Displacement	4.4 L	<b>269 in<sup>3</sup></b>	4.4 L	<b>269 in<sup>3</sup></b>	4.4 L	<b>269 in<sup>3</sup></b>
Max. Implement Hydraulic Pump Output at Rated RPM	190+80 L/min	<b>50+21 gpm</b>	190+80 L/min	<b>50+21 gpm</b>	220+80 L/min	<b>58+21 gpm</b>
Tires — standard	<b>10.00-20 dual pneumatic</b>		<b>10.00-20 dual pneumatic</b>		<b>10.00-20 dual pneumatic</b>	
— optional	<b>11.00-20 dual pneumatic 445/70 R19.5 TL XF</b>		<b>11.00-20 dual pneumatic 445/70 R19.5 TL XF</b>		<b>10.00-20 dual solid rubber 445/70 R19.5 TL XF</b>	
	<b>10.00-20 (dual solid rubber)</b>		<b>10.00-20 (dual solid rubber)</b>		<b>11.00-20 dual pneumatic</b>	
Maximum Drawbar Pull	71 kN	<b>15,961 lbf</b>	71 kN	<b>15,961 lbf</b>	102 kN	<b>22,931 lbf</b>
Maximum Travel Speed	37 km/h	<b>23 mph</b>	37 km/h	<b>23 mph</b>	34 km/h	<b>21 mph</b>
Wheel Base	2500 mm	<b>8'2"</b>	2500 mm	<b>8'2"</b>	2550 mm	<b>8'4"</b>
Width Over Tires**	2550 mm	<b>8'4"</b>	2550 mm	<b>8'4"</b>	2550 mm	<b>8'4"</b>
Ground Clearance**	370 mm	<b>14.7"</b>	370 mm	<b>14.7"</b>	370 mm	<b>14.7"</b>
Fuel Tank Refill Capacity	235 L	<b>62 U.S. gal</b>	235 L	<b>62 U.S. gal</b>	235 L	<b>62 U.S. gal</b>
Hydraulic System (includes tank)	180 L	<b>48 U.S. gal</b>	180 L	<b>48 U.S. gal</b>	220 L	<b>58 U.S. gal</b>

\*Machine weight with medium stick, heavy counterweight, bucket, full fuel tank, and 75 kg (165 lb) operator.

\*\*Tire pressure is 750 kPa (100 psi) with standard tires.

†This product has been discontinued.

**NOTE:** Specifications also vary by Sales area.  
Contact your Cat dealer for details.

MODEL	M315D†		M315D2		M316D†	
Region Offerings	Europe		Africa, Middle East, CIS, China, Asia Pacific, South America		North America, Australia, New Zealand	
Engine Power:						
ISO 9249	101 kW	<b>135 hp</b>	95 kW	<b>129 hp</b>	118 kW	<b>158 hp</b>
ISO 14396	108 kW	<b>145 hp</b>	102 kW	<b>137 hp</b>	123.5 kW	<b>166 hp</b>
Operating Weight*	16 100- 18 300 kg	<b>35,501- 40,352 lb</b>	14 000- 16 200 kg	<b>30,870- 35,721 lb</b>	17 000- 19 200 kg	<b>37,478- 42,329 lb</b>
Bucket Capacity Range (heaped)	0.38-1.26 m <sup>3</sup>	<b>0.5-1.65 yd<sup>3</sup></b>	0.18-0.92 m <sup>3</sup>	<b>0.24-1.2 yd<sup>3</sup></b>	0.35-1.09 m <sup>3</sup>	<b>0.46-1.43 yd<sup>3</sup></b>
Engine Model	<b>C4.4 ACERT</b>		<b>C4.4 ACERT</b>		<b>C6.6 ACERT</b>	
Emission Standards	<b>Stage IIIB</b>		<b>Tier 3/Stage IIIA Equivalent UN/ECE R96 Stage IIIA/ China Nonroad Stage III</b>		<b>Tier 3/Stage IIIA/ UN/ECE R96 Stage IIIA</b>	
Rated Engine RPM	<b>2000</b>		<b>2000</b>		<b>1800</b>	
No. of Cylinders	<b>4</b>		<b>4</b>		<b>6</b>	
Bore	105 mm	<b>4.1"</b>	105 mm	<b>4.1"</b>	105 mm	<b>4.1"</b>
Stroke	127 mm	<b>5"</b>	127 mm	<b>5"</b>	127 mm	<b>5"</b>
Displacement	4.4 L	<b>269 in<sup>3</sup></b>	4.4 L	<b>269 in<sup>3</sup></b>	6.6 L	<b>403 in<sup>3</sup></b>
Max. Implement Hydraulic Pump Output at Rated RPM	220+80 L/min	<b>58+21 gpm</b>	190+80 L/min	<b>50+21 gpm</b>	250+80 L/min	<b>66+21 gpm</b>
Tires — standard	<b>10.00-20 dual pneumatic</b>		<b>10.00-20 dual pneumatic</b>		<b>10.00-20 dual pneumatic</b>	
— optional	<b>10.00-20 dual solid rubber 445/70 R19.5 TL XF 11.00-20 dual pneumatic</b>		<b>10.00-20 dual solid rubber 11.00-20 dual pneumatic 445/70/R19.5 TL XF single pneumatic</b>		<b>10.00-20 dual solid rubber 445/70 R19.5 TL XF 11.00-20 dual pneumatic</b>	
Maximum Drawbar Pull	102 kN	<b>22,931 lbf</b>	71 kN	<b>15,961 lbf</b>	103 kN	<b>23,155 lbf</b>
Maximum Travel Speed	34 km/h	<b>21 mph</b>	37 km/h	<b>23 mph</b>	37 km/h	<b>23 mph</b>
Wheel Base	2550 mm	<b>8'4"</b>	2500 mm	<b>8'2"</b>	2600 mm	<b>8'6"</b>
Width Over Tires**	2550 mm	<b>8'4"</b>	2550 mm	<b>8'4"</b>	2550 mm	<b>8'4"</b>
Ground Clearance**	370 mm	<b>14.7"</b>	370 mm	<b>14.7"</b>	370 mm	<b>14.7"</b>
Fuel Tank Refill Capacity	235 L	<b>62 U.S. gal</b>	235 L	<b>62 U.S. gal</b>	310 L	<b>82 U.S. gal</b>
Hydraulic System (includes tank)	220 L	<b>58 U.S. gal</b>	180 L	<b>48 U.S. gal</b>	230 L	<b>61 U.S. gal</b>

\*Machine weight with medium stick, heavy counterweight, bucket, full fuel tank, and 75 kg (165 lb) operator.

\*\*Tire pressure is 750 kPa (100 psi) with standard tires.

†This product has been discontinued.

**NOTE:** Specifications also vary by Sales area.  
Contact your Cat dealer for details.

MODEL	M317D2		M318D†		M320D2	
Region Offerings	Africa, Middle East, CIS, China, Asia Pacific, South America		Turkey, Australia, New Zealand		Africa, Middle East, CIS, China, Asia Pacific, South America	
Engine Power:						
ISO 9249	101 kW	<b>135 hp</b>	124 kW	<b>166 hp</b>	124 kW	<b>166 hp</b>
ISO 14396	108 kW	<b>145 hp</b>	129.5 kW	<b>174 hp</b>	129 kW	<b>173 hp</b>
Operating Weight*	16 100- 18 300 kg	<b>35,501- 40,352 lb</b>	18 200-20 100 kg	<b>40,124- 44,312 lb</b>	18 200- 20 100 kg	<b>40,124- 44,312 lb</b>
Bucket Capacity Range (heaped)	0.35-1.09 m <sup>3</sup> <b>0.46-1.43 yd<sup>3</sup></b>		0.35-1.18 m <sup>3</sup> <b>0.46-1.54 yd<sup>3</sup></b>		0.35-1.18 m <sup>3</sup> <b>0.46-1.54 yd<sup>3</sup></b>	
Engine Model	<b>C4.4 ACERT</b>		<b>C6.6 ACERT</b>		<b>C7.1 ACERT</b>	
Emission Standards	<b>Tier 3/Stage IIIA Equivalent UN/ECE R96 Stage IIIA/ China Nonroad Stage III</b>		<b>Tier 3/Stage IIIA/ UN/ECE R96 Stage IIIA</b>		<b>Tier 3/Stage IIIA Equivalent UN/ECE R96 Stage IIIA/ China Nonroad Stage III</b>	
Rated Engine RPM	<b>2000</b>		<b>1800</b>		<b>2000</b>	
No. of Cylinders	<b>4</b>		<b>6</b>		<b>6</b>	
Bore	105 mm	<b>4.1"</b>	105 mm	<b>4.1"</b>	105 mm	<b>4.1"</b>
Stroke	127 mm	<b>5"</b>	127 mm	<b>5"</b>	135 mm	<b>5.3"</b>
Displacement	4.4 L	<b>269 in<sup>3</sup></b>	6.6 L	<b>403 in<sup>3</sup></b>	7.01 L	<b>428 in<sup>3</sup></b>
Max. Implement Hydraulic Pump Output at Rated RPM	220+80 L/min	<b>58+21 gpm</b>	290+112 L/min	<b>76+29 gpm</b>	290+112 L/min	<b>76+29 gpm</b>
Tires — standard	<b>10.00-20 dual pneumatic</b>		<b>10.00-20 dual pneumatic</b>		<b>10.00-20 dual pneumatic</b>	
— optional	<b>10.00-20 dual solid rubber</b>		<b>10.00-20 dual solid rubber</b>		<b>10.00-20 dual solid rubber</b>	
	<b>11.00-20 dual pneumatic</b>		<b>445/70 R19.5 TL XF</b>		<b>11.00-20 dual pneumatic</b>	
	<b>445/70/R19.5 TL XF single pneumatic</b>		<b>11.00-20 dual pneumatic</b>		<b>445/70/R19.5 TL XF single pneumatic</b>	
Maximum Drawbar Pull	102 kN	<b>22,931 lbf</b>	103 kN	<b>23,155 lbf</b>	103 kN	<b>23,155 lbf</b>
Maximum Travel Speed	34 km/h	<b>21 mph</b>	37 km/h	<b>23 mph</b>	37 km/h	<b>23 mph</b>
Wheel Base	2550 mm	<b>8'4"</b>	2600 mm	<b>8'6"</b>	2600 mm	<b>8'6"</b>
Width Over Tires**	2550 mm	<b>8'4"</b>	2550 mm	<b>8'4"</b>	2550 mm	<b>8'4"</b>
Ground Clearance**	370 mm	<b>14.7"</b>	370 mm	<b>1'3"</b>	370 mm	<b>14.7"</b>
Fuel Tank Refill Capacity	235 L	<b>62 U.S. gal</b>	385 L	<b>102 U.S. gal</b>	385 L	<b>102 U.S. gal</b>
Hydraulic System (includes tank)	220 L	<b>58 U.S. gal</b>	255 L	<b>67 U.S. gal</b>	255 L	<b>67 U.S. gal</b>

\*Machine weight with medium stick, heavy counterweight, bucket, full fuel tank, and 75 kg (165 lb) operator.

\*\*Tire pressure is 750 kPa (100 psi) with standard tires.

†This product has been discontinued.

**NOTE:** Specifications also vary by Sales area.  
Contact your Cat dealer for details.

MODEL	M322D†		M322D2	
Region Offerings	North America, Australia, New Zealand		Africa, Middle East, CIS, China, Asia Pacific, South America	
Engine Power:				
ISO 9249	123 kW	<b>165 hp</b>	123 kW	<b>165 hp</b>
ISO 14396	129 kW	<b>173 hp</b>	129 kW	<b>173 hp</b>
Operating Weight*	20 500-22 500 kg	<b>45,195-49,604 lb</b>	20 500-22 500 kg	<b>45,195-49,604 lb</b>
Bucket Capacity Range (heaped)	0.44-1.57 m <sup>3</sup>	<b>0.58-2.05 yd<sup>3</sup></b>	0.44-1.57 m <sup>3</sup>	<b>0.58-2.05 yd<sup>3</sup></b>
Engine Model	<b>C6.6 ACERT</b>		<b>C7.1 ACERT</b>	
Emission Standards	<b>Tier 3/Stage IIIA/UN/ECE R96 Stage IIIA</b>		<b>Tier 3/Stage IIIA Equivalent UN/ECE R96 Stage IIIA/China Nonroad Stage III</b>	
Rated Engine RPM	<b>2000</b>		<b>2000</b>	
No. of Cylinders	<b>6</b>		<b>6</b>	
Bore	105 mm	<b>4.1"</b>	105 mm	<b>4.1"</b>
Stroke	127 mm	<b>5"</b>	135 mm	<b>5.3"</b>
Displacement	6.6 L	<b>403 in<sup>3</sup></b>	7.01 L	<b>428 in<sup>3</sup></b>
Max. Implement Hydraulic Pump Output at Rated RPM	350+112 L/min	<b>92+29 gpm</b>	350+112 L/min	<b>92+29 gpm</b>
Tires — standard	<b>11.00-20 dual pneumatic</b>		<b>11.00-20 dual pneumatic</b>	
— optional	<b>11.00-20 dual solid rubber</b>		<b>11.00-20 dual solid rubber</b>	
Maximum Drawbar Pull	127 kN	<b>28,551 lbf</b>	127 kN	<b>28,551 lbf</b>
Maximum Travel Speed	25 km/h	<b>15 mph</b>	25 km/h	<b>15 mph</b>
Wheel Base	2750 mm	<b>9'0"</b>	2750 mm	<b>9'0"</b>
Width Over Tires**	2750 mm	<b>9'0"</b>	2750 mm	<b>9'0"</b>
Ground Clearance**	380 mm	<b>15"</b>	380 mm	<b>15"</b>
Fuel Tank Refill Capacity	385 L	<b>102 U.S. gal</b>	385 L	<b>102 U.S. gal</b>
Hydraulic System (includes tank)	350 L	<b>92.5 U.S. gal</b>	350 L	<b>92 U.S. gal</b>

\*Machine weight with medium stick, heavy counterweight, bucket, full fuel tank, and 75 kg (165 lb) operator.

\*\*Tire pressure is 750 kPa (100 psi) with standard tires.

†This product has been discontinued.

**NOTE:** Specifications also vary by Sales area.  
Contact your Cat dealer for details.



MODEL	M314F		M316F		M318F	
Region Offerings	Europe, North America, Australia, New Zealand		Europe, North America, Australia, New Zealand		Europe, North America, Australia, New Zealand	
Engine Power:						
ISO 9249	105 kW	<b>141 hp</b>	105 kW	<b>141 hp</b>	126 kW	<b>169 hp</b>
ISO 14396	110 kW	<b>148 hp</b>	110 kW	<b>148 hp</b>	129.4 kW	<b>174 hp</b>
Operating Weight*	14 200- 16 400 kg	<b>31,306- 36,156 lb</b>	16 100- 18 500 kg	<b>35,494- 40,785 lb</b>	16 900- 36 817 kg	<b>19,700- 42,549 lb</b>
Bucket Capacity Range (heaped)	0.18-0.92 m <sup>3</sup> <b>0.24-1.2 yd<sup>3</sup></b>		0.38-1.26 m <sup>3</sup> <b>0.5-1.65 yd<sup>3</sup></b>		0.35-1.09 m <sup>3</sup> <b>0.46-1.43 yd<sup>3</sup></b>	
Engine Model	<b>C4.4 ACERT</b>		<b>C4.4 ACERT</b>		<b>C7.1 ACERT</b>	
Emission Standards	<b>Tier 4 Final/Stage IV/ Japan 2014 (Tier 4 Final)</b>		<b>Tier 4 Final/Stage IV/ Japan 2014 (Tier 4 Final)</b>		<b>Tier 4 Final/Stage IV/ Japan 2014 (Tier 4 Final)</b>	
Rated Engine RPM	<b>2000</b>		<b>2000</b>		<b>1750</b>	
No. of Cylinders	<b>4</b>		<b>4</b>		<b>6</b>	
Bore	105 mm	<b>4.1"</b>	105 mm	<b>4.1"</b>	105 mm	<b>4.1"</b>
Stroke	127 mm	<b>5.0"</b>	127 mm	<b>5.0"</b>	135 mm	<b>5.3"</b>
Displacement	4.40 L	<b>269 in<sup>3</sup></b>	4.40 L	<b>269 in<sup>3</sup></b>	7.01 L	<b>428 in<sup>3</sup></b>
Max. Implement Hydraulic Pump Output at Rated RPM	190+80 L/min	<b>50+21 gpm</b>	220+80 L/min	<b>58+21 gpm</b>	252+85 L/min	<b>67+22 gpm</b>
Tires — standard	<b>10.00-20 dual pneumatic</b>		<b>10.00-20 dual pneumatic</b>		<b>10.00-20 dual pneumatic</b>	
— optional	<b>11.00-20 dual pneumatic 445/70/R19.5 TL XF single pneumatic</b>		<b>11.00-20 dual pneumatic 445/70/R19.5 TL XF single pneumatic</b>		<b>10.00-20 dual solid rubber 11.00-20 dual pneumatic 445/70/R19.5 TL XF single pneumatic</b>	
Maximum Drawbar Pull	71 kN	<b>15,961 lbf</b>	102 kN	<b>22,931 lbf</b>	103 kN	<b>23,155 lbf</b>
Maximum Travel Speed	37 km/h	<b>23 mph</b>	34 km/h	<b>21 mph</b>	35 km/h	<b>22 mph</b>
Wheel Base	2500 mm	<b>8'2"</b>	2550 mm	<b>8'4"</b>	2600 mm	<b>8'6"</b>
Width Over Tires**	2550 mm	<b>8'4"</b>	2550 mm	<b>8'4"</b>	2550 mm	<b>8'4"</b>
Ground Clearance**	370 mm	<b>14.7"</b>	370 mm	<b>14.7"</b>	370 mm	<b>14.7"</b>
Fuel Tank Refill Capacity	275 L	<b>73 U.S. gal</b>	325 L	<b>86 U.S. gal</b>	325 L	<b>86 U.S. gal</b>
DEF Tank Refill Capacity	19 L	<b>5 U.S. gal</b>	19 L	<b>5 U.S. gal</b>	35 L	<b>9.2 U.S. gal</b>
Hydraulic System (includes tank)	149 L	<b>39 U.S. gal</b>	199 L	<b>53 U.S. gal</b>	210 L	<b>56 U.S. gal</b>

\*Machine weight with medium stick, heavy counterweight, bucket, full fuel tank, and 75 kg (165 lb) operator.

\*\*Tire pressure is 750 kPa (100 psi) with standard tires.

**NOTE:** Specifications also vary by Sales area.  
Contact your Cat dealer for details.

MODEL	M320F		M322F	
Region Offerings	Europe, North America, Australia, New Zealand		Europe, North America, Australia, New Zealand	
Engine Power:				
ISO 9249	126 kW	<b>169 hp</b>	126 kW	<b>169 hp</b>
ISO 14396	129.4 kW	<b>174 hp</b>	129.4 kW	<b>174 hp</b>
Operating Weight*	18 500-20 650 kg	<b>40,785-46,385 lb</b>	20 700-24 100 kg	<b>45,635-53,131 lb</b>
Bucket Capacity Range (heaped)	0.35-1.18 m <sup>3</sup>	<b>0.46-1.54 yd<sup>3</sup></b>	0.44-1.57 m <sup>3</sup>	<b>0.58-2.05 yd<sup>3</sup></b>
Engine Model	<b>C7.1 ACERT</b>		<b>C7.1 ACERT</b>	
Emission Standards	<b>Tier 4 Final/Stage IV/ Japan 2014 (Tier 4 Final)</b>		<b>Tier 4 Final/Stage IV/ Japan 2014 (Tier 4 Final)</b>	
Rated Engine RPM	<b>1550</b>		<b>1700</b>	
No. of Cylinders	<b>6</b>		<b>6</b>	
Bore	105 mm	<b>4.1"</b>	105 mm	<b>4.1"</b>
Stroke	135 mm	<b>5.3"</b>	135 mm	<b>5.3"</b>
Displacement	7.01 L	<b>428 in<sup>3</sup></b>	7.01 L	<b>428 in<sup>3</sup></b>
Max. Implement Hydraulic Pump Output at Rated RPM	294+110 L/min	<b>78+29 gpm</b>	357+120 L/min	<b>94+32 gpm</b>
Tires — standard	<b>10.00-20 dual pneumatic</b>		<b>11.00-20 dual pneumatic</b>	
— optional	<b>10.00-20 dual solid rubber</b>		<b>11.00-20 dual solid rubber</b>	
	<b>11.00-20 dual pneumatic</b>			
	<b>445/70/R19.5TL XF single pneumatic</b>			
Maximum Drawbar Pull	103 kN	<b>23,155 lbf</b>	127 kN	<b>28,551 lbf</b>
Maximum Travel Speed	35 km/h	<b>22 mph</b>	30 km/h	<b>19 mph</b>
Wheel Base	2600 mm	<b>8'6"</b>	2750 mm	<b>9'0"</b>
Width Over Tires**	2550 mm	<b>8'4"</b>	2750 mm	<b>9'0"</b>
Ground Clearance**	370 mm	<b>14.7"</b>	380 mm	<b>15"</b>
Fuel Tank Refill Capacity	415 L	<b>110 U.S. gal</b>	415 L	<b>110 U.S. gal</b>
DEF Tank Refill Capacity	35 L	<b>9.2 U.S. gal</b>	35 L	<b>9.2 U.S. gal</b>
Hydraulic System (includes tank)	240 L	<b>63 U.S. gal</b>	352 L	<b>93 U.S. gal</b>

\*Machine weight with medium stick, heavy counterweight, bucket, full fuel tank, and 75 kg (165 lb) operator.

\*\*Tire pressure is 750 kPa (100 psi) with standard tires.

**NOTE:** Specifications also vary by Sales area.

Contact your Cat dealer for details.

MODEL	320D2		320D2 GC		320D2 L	
Region Offerings	Asia Pacific, China, Latin America		Africa, Middle East, CIS Asia Pacific, China, Latin America		Africa, Middle East, CIS Asia Pacific, China, Latin America	
Engine Power:	N/A		N/A		N/A	
ISO 9249	N/A		N/A		N/A	
SAE J1349	109 kW	<b>146 hp</b>	80 kW	<b>107 hp</b>	109 kW	<b>146 hp</b>
Operating Weight*	20 900- 21 700 kg	<b>46,100- 49,200 lb</b>	20 000- 20 600 kg	<b>44,100- 45,400 lb</b>	21 400- 22 300 kg	<b>47,200- 49,200 lb</b>
Bucket Capacity Range (heaped)	1.0-1.56 m <sup>3</sup>	<b>1.3-2.04 yd<sup>3</sup></b>	0.9 m <sup>3</sup>	<b>1.17 yd<sup>3</sup></b>	1.0-1.56 m <sup>3</sup>	<b>1.3-2.04 yd<sup>3</sup></b>
Engine Model	<b>C7.1</b>		<b>C4.4</b>		<b>C7.1 ACERT</b>	
Emission Standards	<b>Tier 3/Stage III Equivalent/ China Nonroad Stage III</b>		<b>Tier 3/Stage III Equivalent/ China Nonroad Stage III</b>		<b>Tier 3/Stage III Equivalent/ China Nonroad Stage III</b>	
Rated Engine RPM	<b>1800</b>		<b>1800</b>		<b>1800</b>	
No. of Cylinders	<b>6</b>		<b>4</b>		<b>6</b>	
Bore	105 mm	<b>4.1"</b>	105 mm	<b>4.13"</b>	105 mm	<b>4.1"</b>
Stroke	135 mm	<b>5.3"</b>	127 mm	<b>5.00"</b>	135 mm	<b>5.3"</b>
Displacement	7.01 L	<b>428 in<sup>3</sup></b>	4.4 L	<b>269 in<sup>3</sup></b>	7.01 L	<b>428 in<sup>3</sup></b>
Max. Implement Hydraulic Pump Output at Rated RPM	2 × 202 L/min	<b>2 × 53.36 gpm</b>	2 × 214 L/min	<b>2 × 56.55 gpm</b>	2 × 202 L/min	<b>2 × 53.36 gpm</b>
Relief Valve Settings:						
Implement Circuits	35 000 kPa	<b>5076 psi</b>	35 000 kPa	<b>5076 psi</b>	35 000 kPa	<b>5076 psi</b>
Travel Circuits	35 000 kPa	<b>5076 psi</b>	35 000 kPa	<b>5076 psi</b>	—	
Swing Circuits	25 000 kPa	<b>3626 psi</b>	25 000 kPa	<b>3626 psi</b>	35 000 kPa	<b>5076 psi</b>
Pilot Circuits	3900 kPa	<b>566 psi</b>	3900 kPa	<b>566 psi</b>	25 000 kPa	<b>3626 psi</b>
Maximum Drawbar Pull	205 kN	<b>46,086 lbf</b>	206 kN	<b>46,311 lbf</b>	3900 kPa	<b>566 psi</b>
					205 kN	<b>46,086 lbf</b>
Maximum Travel Speed at Rated RPM	5.4 km/h	<b>3.3 mph</b>	5.8 km/h	<b>3.6 mph</b>	5.4 km/h	<b>3.3 mph</b>
Width of Standard Track Shoe	600 mm	<b>2'0"</b>	600 mm	<b>2'0"</b>	600 mm	<b>2'0"</b>
Overall Track Length	4080 mm	<b>13'5"</b>	4080 mm	<b>13'5"</b>	4460 mm	<b>14'8"</b>
Ground Contact Area with Std. Shoe	4.3 m <sup>2</sup>	<b>6600 in<sup>2</sup></b>	4.3 m <sup>2</sup>	<b>6600 in<sup>2</sup></b>	4.7 m <sup>2</sup>	<b>7285 in<sup>2</sup></b>
Track Gauge	2200 mm	<b>7'3"</b>	2200 mm	<b>7'3"</b>	2380 mm	<b>7'10"</b>
Fuel Tank Refill Capacity	410 L	<b>108.3 U.S. gal</b>	410 L	<b>108.3 U.S. gal</b>	410 L	<b>108.3 U.S. gal</b>
Hydraulic System (includes tank)	260 L	<b>68.7 U.S. gal</b>	260 L	<b>68.7 U.S. gal</b>	260 L	<b>68.7 U.S. gal</b>

\*Operating weight includes coolant, lubricants, full fuel tank, standard shoes, bucket and operator 75 kg (165 lb).

**NOTE:** Certain models may not be available in all Sales areas.

Specifications also vary by Sales area.

Contact your Cat dealer for details.

MODEL	320E		320E L		320E LRR	
Region Offerings	Japan		Japan		North America	
Engine Power:						
ISO 9249	114 kW	<b>153 hp</b>	114 kW	<b>153 hp</b>	N/A	
SAE J1349	107 kW	<b>144 hp</b>	107 kW	<b>144 hp</b>	114 kW	<b>153 hp</b>
Operating Weight*	21 700- 24 700 kg	<b>47,840- 54,500 lb</b>	21 700- 23 500 kg	<b>47,840- 51,800 lb</b>	23 700- 25 600 kg	<b>52,250- 56,440 lb</b>
Bucket Capacity Range (heaped)	0.8-1.0 m <sup>3</sup>	<b>1.05-1.31 yd<sup>3</sup></b>	0.46-1.43 m <sup>3</sup>	<b>0.6-1.87 yd<sup>3</sup></b>	0.55-1.59 m <sup>3</sup>	<b>0.72-2.08 yd<sup>3</sup></b>
Engine Model	<b>C6.6 ACERT</b>		<b>C6.6 ACERT</b>		<b>C6.6 ACERT</b>	
Emission Standards	<b>Japan 2011 (Tier 4 Interim) Equivalent</b>		<b>Japan 2011 (Tier 4 Interim) Equivalent</b>		<b>Tier 4 Interim Equivalent</b>	
Rated Engine RPM	<b>1800</b>		<b>1800</b>		<b>1800</b>	
No. of Cylinders	<b>6</b>		<b>6</b>		<b>6</b>	
Bore	105 mm	<b>4.1"</b>	105 mm	<b>4.1"</b>	105 mm	<b>4.1"</b>
Stroke	127 mm	<b>5.0"</b>	127 mm	<b>5.0"</b>	127 mm	<b>5.0"</b>
Displacement	6.6 L	<b>403 in<sup>3</sup></b>	6.6 L	<b>403 in<sup>3</sup></b>	6.6 L	<b>403 in<sup>3</sup></b>
Max. Implement Hydraulic Pump Output at Rated RPM	428 L/min	<b>113.1 gpm</b>	428 L/min	<b>113.1 gpm</b>	428 L/min	<b>113.1 gpm</b>
Relief Valve Settings:						
Implement Circuits	35 000 kPa	<b>5076 psi</b>	35 000 kPa	<b>5076 psi</b>	35 000 kPa	<b>5076 psi</b>
Heavy Lift	38 000 kPa	<b>5511 psi</b>	38 000 kPa	<b>5511 psi</b>	38 000 kPa	<b>5511 psi</b>
Travel Circuits	35 000 kPa	<b>5076 psi</b>	35 000 kPa	<b>5076 psi</b>	35 000 kPa	<b>5076 psi</b>
Swing Circuits	25 000 kPa	<b>3626 psi</b>	25 000 kPa	<b>3626 psi</b>	25 000 kPa	<b>3626 psi</b>
Pilot Circuits	3920 kPa	<b>569 psi</b>	3920 kPa	<b>569 psi</b>	3920 kPa	<b>569 psi</b>
Maximum Drawbar Pull	205 kN	<b>46,086 lbf</b>	205 kN	<b>46,086 lbf</b>	205 kN	<b>46,086 lbf</b>
Maximum Travel Speed at Rated RPM	5.6 km/h	<b>3.5 mph</b>	5.6 km/h	<b>3.5 mph</b>	5.6 km/h	<b>3.5 mph</b>
Width of Standard Track Shoe	600 mm	<b>24"</b>	600 mm	<b>24"</b>	790 mm	<b>31"</b>
Overall Track Length	4075 mm	<b>14'7"</b>	4460 mm	<b>14'6"</b>	4460 mm	<b>14'7"</b>
Ground Contact Area with Std. Shoe	4.3 m <sup>2</sup>	<b>6600 in<sup>2</sup></b>	4.7 m <sup>2</sup>	<b>7300 in<sup>2</sup></b>	6.2 m <sup>2</sup>	<b>9600 in<sup>2</sup></b>
Track Gauge	2200 mm	<b>7'3"</b>	2380 mm	<b>7'10"</b>	2380 mm	<b>7'10"</b>
Fuel Tank Refill Capacity	410 L	<b>108.3 U.S. gal</b>	410 L	<b>108.3 U.S. gal</b>	290 L	<b>76.6 U.S. gal</b>
Hydraulic System (includes tank)	260 L	<b>68.7 U.S. gal</b>	260 L	<b>68.7 U.S. gal</b>	205 L	<b>54.2 U.S. gal</b>

\*Operating weight includes coolant, lubricants, full fuel tank, standard shoes, bucket and operator 75 kg (165 lb).

**NOTE:** Certain models may not be available in all Sales areas.

Specifications also vary by Sales area.  
Contact your Cat dealer for details.

MODEL	320F L		323D2 L		323F L	
Region Offerings	North America, Europe, Australia, New Zealand		Africa, Middle East, China, Latin America		North America, Europe, Australia, New Zealand	
Engine Power:	N/A		110 kW	149 hp	120 kW	161 hp
ISO 9249			N/A		120 kW	161 hp
SAE J1349	120 kW	161 hp			120 kW	161 hp
Operating Weight*	21 600- 22 300 kg	47,600- 49,200 lb	21 990- 23 300 kg	48,480- 51,370 lb	23 100 kg	50,900 lb
Bucket Capacity Range (heaped)	0.55-1.59 m <sup>3</sup>	0.72-2.08 yd <sup>3</sup>	1.0-1.76 m <sup>3</sup>	1.3-2.3 yd <sup>3</sup>	0.55-1.59 m <sup>3</sup>	0.72-2.08 yd <sup>3</sup>
Engine Model	C4.4 ACERT		C7.1 ACERT		C7.1 ACERT	
Emission Standards	Tier 4 Final/Stage IV		Tier 2/Stage II/ China Nonroad Stage II Equivalent OR Tier 3/Stage IIIA Equivalent/ China Nonroad Stage III		Tier 4 Final/Stage IV	
Rated Engine RPM	1800		1800		1800	
No. of Cylinders	4		6		6	
Bore	105 mm	4.13"	105 mm	4.13"	105 mm	4.1"
Stroke	127 mm	5.00"	135 mm	5.31"	135 mm	5.3"
Displacement	4.4 L	269 in <sup>3</sup>	7.01 L	428 in <sup>3</sup>	7.1 L	433 in <sup>3</sup>
Max. Implement Hydraulic Pump Output at Rated RPM	2 × 214 L/min	2 × 111.3 gpm	2 × 214 L/min	2 × 56.5 gpm	2 × 212 L/min	2 × 56 gpm
Relief Valve Settings:						
Implement Circuits	35 000 kPa	5076 psi	35 000 kPa	5076 psi	35 000 kPa	5076 psi
Heavy Lift	—		—		38 000 kPa	5511 psi
Travel Circuits	35 000 kPa	5076 psi	35 000 kPa	5076 psi	35 000 kPa	5076 psi
Swing Circuits	25 000 kPa	3626 psi	25 000 kPa	3626 psi	25 500 kPa	3698 psi
Pilot Circuits	3920 kPa	569 psi	3920 kPa	569 psi	3920 kPa	569 psi
Maximum Drawbar Pull	205 kN	46,086 lbf	205 kN	46,086 lbf	205 kN	46,060 lbf
			Two Speed Travel			
Maximum Travel Speed at Rated RPM	5.6 km/h	3.5 mph	Lo: 3.5 km/h Hi: 5.6 km/h	2.1 mph 3.5 mph	5.5 km/h	3.4 mph
Width of Standard Track Shoe	790 mm	31"	600 mm	2'0"	790 mm	31"
Overall Track Length	4460 mm	14'8"	4455mm	14'7"	4460 mm	14'8"
Ground Contact Area with Std. Shoe	6.2 m <sup>2</sup>	9600 in <sup>2</sup>	4.7 m <sup>2</sup>	7300 in <sup>2</sup>	6.2 m <sup>2</sup>	9600 in <sup>2</sup>
Track Gauge	2380 mm	7'10"	2380 mm	7'1"	2380 mm	7'10"
Fuel Tank Refill Capacity	410 L	108.3 U.S. gal	410 L	108 U.S. gal	410 L	108.3 U.S. gal
Hydraulic System (includes tank)	260 L	68.7 U.S. gal	260 L	68.7 U.S. gal	159 L	42 U.S. gal

\*Operating weight includes coolant, lubricants, full fuel tank, standard shoes, bucket and operator 75 kg (165 lb).

NOTE: Certain models may not be available in all Sales areas.

Specifications also vary by Sales area.

Contact your Cat dealer for details.

MODEL	323F LN		325F L		326D2 L	
Region Offerings	Europe		North America, Europe, Australia, New Zealand, Japan, Hong Kong, Taiwan		South America, Middle East, Africa, CIS, Asia Pacific, China	
Engine Power:	N/A		120 kW	161 hp	141 kW	189 hp
ISO 9249	N/A		120 kW	161 hp	N/A	
SAE J1349	120 kW	161 hp	120 kW	161 hp	N/A	
Operating Weight*	22 300- 23 600 kg	49,200- 52,000 lb	25 349- 26 364 kg	55,885- 58,123 lb	24 815- 26 345 kg	54,710- 58,080 lb
Bucket Capacity Range (heaped)	0.8-1.7 m <sup>3</sup>	1.05-2.2 yd <sup>3</sup>	0.8-1.7 m <sup>3</sup>	1.05-2.2 yd <sup>3</sup>	0.5-2.3 m <sup>3</sup>	0.65-3.01 yd <sup>3</sup>
Engine Model	C4.4 ACERT		C4.4 ACERT		C7.1 ACERT	
Emission Standards	Stage IV		Tier 4 Final/Stage IV/ Japan 2014 (Tier 4 Final)		Tier 2/Stage II/ China Nonroad Stage II Equivalent OR Tier 3/Stage IIIA Equivalent/ China Nonroad Stage III	
Rated Engine RPM	1800		1800		1800	
No. of Cylinders	4		4		6	
Bore	105 mm	4"	105 mm	4"	—	
Stroke	127 mm	5"	127 mm	5"	—	
Displacement	4.4 L	269 in <sup>3</sup>	4.4 L	269 in <sup>3</sup>	7.01 L	428 in <sup>3</sup>
Max. Implement Hydraulic Pump Output at Rated RPM	2 × 214.4 L/min	2 × 56.6 gpm	2 × 214.4 L/min	2 × 56.6 gpm	2 × 247 L/min	2 × 65.2 gpm
Relief Valve Settings:						
Implement Circuits	35 000 kPa	5075 psi	35 000 kPa	5075 psi	35 MPa	5076.4 psi
Travel Circuits	35 000 kPa	5075 psi	35 000 kPa	5075 psi	35 MPa	5076.4 psi
Swing Circuits	25 500 kPa	3698 psi	25 500 kPa	3698 psi	24.5 MPa	3555.9 psi
Pilot Circuits	4100 kPa	595 psi	4100 kPa	595 psi	3920 kPa	586.6 psi
Maximum Drawbar Pull	205 kN	46,090 lbf	203 kN	45,591 lbf	227 kN	51,032 lbf
Maximum Travel Speed at Rated RPM	5.6 km/h	3.5 mph	Two Speed Travel Lo: 3.5 km/h 2.2 mph Hi: 5.6 km/h 3.5 mph		5.8 km/h	3.6 mph
Width of Standard Track Shoe	500 mm	20"	790 mm	31"	790 mm	31"
Overall Track Length	4450 mm	14'8"	4460 mm	14'8"	4630 mm	15'2"
Ground Contact Area with Std. Shoe	3.92 m <sup>2</sup>	6090 in <sup>2</sup>	6.21 m <sup>2</sup>	9623 in <sup>2</sup>	6.5 m <sup>2</sup>	10,100 in <sup>2</sup>
Track Gauge	2000 mm	6'7"	3170 mm	10'5"	2590 mm	8'6"
Fuel Tank Refill Capacity	310 L	81.9 U.S. gal	310 L	81.9 U.S. gal	520 L	137.4 U.S. gal
Hydraulic System (includes tank)	260 L	68.7 U.S. gal	280 L	74.0 U.S. gal	285 L	75.3 U.S. gal

\*Operating weight includes coolant, lubricants, full fuel tank, standard shoes, bucket and operator 75 kg (165 lb).

NOTE: Certain models may not be available in all Sales areas.

Specifications also vary by Sales area.

Contact your Cat dealer for details.

MODEL	326F L		326F LN		330D2 L	
Region Offerings	Japan, Europe, North America, Australia, New Zealand		Europe		South America, Middle East, Africa, CIS, Asia Pacific, China	
Engine Power:						
ISO 9249	149 kW	<b>203 hp</b>	149 kW	<b>203 hp</b>	151 kW	<b>203 hp</b>
SAE J1349	149 kW	<b>203 hp</b>	149 kW	<b>203 hp</b>	N/A	
Operating Weight*	24 878- 29 407 kg	<b>54,847- 64,831 lb</b>	24 784- 29 702 kg	<b>54,637- 65,479 lb</b>	27 835- 30 115 kg	<b>61,370- 66,390 lb</b>
Bucket Capacity Range (heaped)	1.3-2.12 m <sup>3</sup>	<b>1.7-2.8 yd<sup>3</sup></b>	1.3-2.12 m <sup>3</sup>	<b>1.7-2.8 yd<sup>3</sup></b>	0.57-2.35 m <sup>3</sup>	<b>0.78-3.08 yd<sup>3</sup></b>
Engine Model	<b>C7.1 ACERT</b>		<b>C7.1 ACERT</b>		<b>C7.1 ACERT</b>	
Emission Standards	<b>Tier 4 Final/Stage IV/ Japan 2014 (Tier 4 Final)</b>		<b>Stage IV</b>		<b>Tier 2/Stage II/ China Nonroad Stage II Equivalent OR Tier 3/Stage IIIA Equivalent/ China Nonroad Stage III</b>	
Rated Engine RPM	<b>1800</b>		<b>1800</b>		<b>1800</b>	
No. of Cylinders	<b>6</b>		<b>6</b>		<b>6</b>	
Displacement	7.01 L	<b>428 in<sup>3</sup></b>	7.01 L	<b>428 in<sup>3</sup></b>	7.01 L	<b>428 in<sup>3</sup></b>
Max. Implement Hydraulic Pump Output at Rated RPM	2 x 253.5 L/min	<b>2 x 67 gpm</b>	2 x 254 L/min	<b>2 x 67 gpm</b>	2 x 254 L/min	<b>2 x 67.1 gpm</b>
Relief Valve Settings:						
Implement Circuits	35 000 kPa	<b>5076 psi</b>	35 000 kPa	<b>5076 psi</b>	35 000 kPa	<b>5076.4 psi</b>
Travel Circuits	37 000 kPa	<b>5366 psi</b>	35 000 kPa	<b>5076 psi</b>	35 000 kPa	<b>5076.4 psi</b>
Swing Circuits	27 400 kPa	<b>3973 psi</b>	27 400 kPa	<b>3974 psi</b>	27 500 kPa	<b>3982.7 psi</b>
Pilot Circuits	4100 kPa	<b>595 psi</b>	2500 kPa	<b>363 psi</b>	3920 kPa	<b>568.6 psi</b>
Maximum Drawbar Pull	226 kN	<b>50,807 lbf</b>	226 kN	<b>50,807 lbf</b>	248 kN	<b>55,752.6 lbf</b>
Maximum Travel Speed at Rated RPM	5.3 km/h	<b>3.3 mph</b>	5.3 km/h	<b>3.3 mph</b>	5.3 km/h	<b>3.4 mph</b>
Width of Standard Track Shoe	600 mm	<b>2'0"</b>	790 mm	<b>31"</b>	600 mm	<b>24"</b>
Overall Track Length	4641 mm	<b>15'3"</b>	4641 mm	<b>15'3"</b>	4860 mm	<b>15'11"</b>
Ground Contact Area with Std. Shoe	4.5 m <sup>2</sup>	<b>6950 in<sup>2</sup></b>	6.5 m <sup>2</sup>	<b>10,100 in<sup>2</sup></b>	5.2 m <sup>2</sup>	<b>8000 in<sup>2</sup></b>
Track Gauge	2590 mm	<b>8'6"</b>	2390 mm	<b>7'10"</b>	2590 mm	<b>8'6"</b>
Fuel Tank Refill Capacity	520 L	<b>137.4 U.S. gal</b>	520 L	<b>137 U.S. gal</b>	520 L	<b>137.4 U.S. gal</b>
Hydraulic System (includes tank)	285 L	<b>75.3 U.S. gal</b>	285 L	<b>75.3 U.S. gal</b>	310 L	<b>81.9 U.S. gal</b>

\*Operating weight includes coolant, lubricants, full fuel tank, standard shoes, bucket and operator 75 kg (165 lb).

**NOTE:** Certain models may not be available in all Sales areas.

Specifications also vary by Sales area.

Contact your Cat dealer for details.

MODEL	330F L		330F LN	
Region Offerings	Japan, Europe, North America, Australia, New Zealand, South Korea		Europe	
Engine Power:				
ISO 9249	175 kW	239 hp	173 kW	235 hp
SAE J1349	N/A		N/A	
Operating Weight*	28 577-30 939 kg	63,002-68,209 lb	28 293-31 299 kg	62,372-68,999 lb
Bucket Capacity Range (heaped)	0.45-2.12 m <sup>3</sup>	0.6-2.8 yd <sup>3</sup>	1.5-2.12 m <sup>3</sup>	2.0-2.8 yd <sup>3</sup>
Engine Model	C7.1 ACERT		C7.1 ACERT	
Emission Standards	Tier 4 Final/Stage IV/Korea Tier 4/ Japan 2014 (Tier 4 Final)		Stage IV	
Rated Engine RPM	1800		1800	
No. of Cylinders	6		6	
Displacement	7.01 L	428 in <sup>3</sup>	7.01 L	428 in <sup>3</sup>
Max. Implement Hydraulic Pump Output at Rated RPM	2 x 246.5 L/min	2 x 65 gpm	2 x 246.6 L/min	2 x 65.1 gpm
Relief Valve Settings:				
Implement Circuits	35 000 kPa	5076 psi	35 000 kPa	5076 psi
Travel Circuits	37 000 kPa	5366 psi	37 000 kPa	5366 psi
Swing Circuits	27 400 kPa	3974 psi	27 400 kPa	3974 psi
Pilot Circuits	4100 kPa	595 psi	2500 kPa	363 psi
Maximum Drawbar Pull	247 kN	55,528 lbf	247 kN	55,528 lbf
Maximum Travel Speed at Rated RPM	5.1 km/h	3.2 mph	5.1 km/h	3.2 mph
Width of Standard Track Shoe	800 mm	3'2"	600 mm	24"
Overall Track Length	4860 mm	15'11"	4855 mm	15'11"
Ground Contact Area with Std. Shoe	6.88 m <sup>2</sup>	10,664 in <sup>2</sup>	5.16 m <sup>2</sup>	7998 in <sup>2</sup>
Track Gauge	2590 mm	8'6"	2390 mm	7'10"
Fuel Tank Refill Capacity	520 L	137.4 U.S. gal	520 L	137.4 U.S. gal
Hydraulic System (includes tank)	310 L	81.9 U.S. gal	310 L	82 U.S. gal

\*Operating weight includes coolant, lubricants, full fuel tank, standard shoes, bucket and operator 75 kg (165 lb).

**NOTE:** Certain models may not be available in all Sales areas.

Specifications also vary by Sales area.  
Contact your Cat dealer for details.



MODEL	335F L		336D2	
Region Offerings	Europe, North America, Australia, New Zealand, Hong Kong, Taiwan		Asia Pacific	
Engine Power:				
ISO 9249	149 kW	200 hp	200 kW	268 hp
SAE J1349	N/A		N/A	
Operating Weight*	34 735-37 967 kg	76,578-83,703 lb	34 489-37 086 kg	76,035-81,761 lb
Bucket Capacity Range (heaped)	0.52-2.15 m <sup>3</sup>	0.68-2.81 yd <sup>3</sup>	1.4-2.0 m <sup>3</sup>	1.83-2.49 yd <sup>3</sup>
Engine Model	C7.1 ACERT		C9 ACERT	
Emission Standards	Tier 4 Final/Stage IV		Tier 2/Stage II Equivalent	
Rated Engine RPM	1800		1800	
No. of Cylinders	6		6	
Displacement	7.01 L	428 in <sup>3</sup>	8.8 L	537 in <sup>3</sup>
Max. Implement Hydraulic Pump Output at Rated RPM	2 × 246.6 L/min	2 × 65.1 gpm	2 × 265 L/min	2 × 70 gpm
Relief Valve Settings:				
Implement Circuits	35 000 kPa	5076 psi	35 000 kPa	5076 psi
Travel Circuits	37 000 kPa	5366 psi	35 000 kPa	5076 psi
Swing Circuits	27 400 kPa	3974 psi	28 000 kPa	4061 psi
Pilot Circuits	4100 kPa	595 psi	4000 kPa	580.2 psi
Maximum Drawbar Pull	295 kN	66,319 lbf	300.5 kN	67,555 lbf
Maximum Travel Speed at Rated RPM	4.2 km/h	2.6 mph	4.85 km/h	3.0 mph
Width of Standard Track Shoe	850 mm	33"	600 mm	24"
Overall Track Length	5020 mm	16'6"	4590 mm	15'1"
Ground Contact Area with Std. Shoe	7.46 m <sup>2</sup>	11,560 in <sup>2</sup>	4.7 m <sup>2</sup>	7350 in <sup>2</sup>
Track Gauge	2590 mm	8'6"	2590 mm	8'6"
Fuel Tank Refill Capacity	385 L	101.7 U.S. gal	620 L	163.79 U.S. gal
DEF Tank Refill Capacity	154 L	40.7 U.S. gal	—	—
Hydraulic System (includes tank)	290 L	76.6 U.S. gal	410 L	108.31 U.S. gal

\*Operating weight includes coolant, lubricants, full fuel tank, standard shoes, bucket and operator 75 kg (165 lb).

NOTE: Certain models may not be available in all Sales areas.

Specifications also vary by Sales area.  
Contact your Cat dealer for details.

MODEL	336D2 GC		336D2 L		336D2 L	
Region Offerings	China		Asia Pacific, South America		Middle East, Africa	
Engine Power:						
ISO 9249	201 kW	<b>270 hp</b>	200 kW	<b>268 hp</b>	200 kW	<b>268 hp</b>
SAE J1349	201 kW	<b>270 hp</b>	N/A		N/A	
Operating Weight*	32 900 kg	<b>72,500 lb</b>	34 489- 37 086 kg	<b>76,035- 81,761 lb</b>	34 489- 37 086 kg	<b>76,035- 81,761 lb</b>
Bucket Capacity Range (heaped)	1.64 m <sup>3</sup>	<b>2.14 yd<sup>3</sup></b>	0.7-2.2 m <sup>3</sup>	<b>0.9-3.0 yd<sup>3</sup></b>	1.11-2.4 m <sup>3</sup>	<b>1.45-3.14 yd<sup>3</sup></b>
Engine Model	<b>C9 ACERT</b>		<b>C9 ACERT</b>		<b>C9 ACERT</b>	
Emission Standards	<b>China Nonroad Stage III</b>		<b>Tier 2/Stage II Equivalent</b>		<b>Tier 2/Stage II Equivalent</b>	
Rated Engine RPM	<b>1800</b>		<b>1800</b>		<b>1800</b>	
No. of Cylinders	<b>6</b>		<b>6</b>		<b>6</b>	
Bore	112 mm	<b>4.41"</b>	—		—	
Stroke	149 mm	<b>5.87"</b>	—		—	
Displacement	8.8 L	<b>537 in<sup>3</sup></b>	8.8 L	<b>537 in<sup>3</sup></b>	8.8 L	<b>537 in<sup>3</sup></b>
Max. Implement Hydraulic Pump Output at Rated RPM	562 L/min	<b>148 gpm</b>	2 x 265 L/min	<b>2 x 70 gpm</b>	2 x 265 L/min	<b>2 x 70 gpm</b>
Relief Valve Settings:						
Implement Circuits	35 000 kPa	<b>5076 psi</b>	35 000 kPa	<b>5076 psi</b>	35 000 kPa	<b>5076 psi</b>
Travel Circuits	35 000 kPa	<b>5076 psi</b>	35 000 kPa	<b>5076 psi</b>	35 000 kPa	<b>5076 psi</b>
Swing Circuits	28 000 kPa	<b>4061 psi</b>	28 000 kPa	<b>4061 psi</b>	28 000 kPa	<b>4061 psi</b>
Pilot Circuits	4000 kPa	<b>580 psi</b>	4000 kPa	<b>580.2 psi</b>	4000 kPa	<b>580.2 psi</b>
Maximum Drawbar Pull	302 kN	<b>67,780 lbf</b>	300.5 kN	<b>67,555 lbf</b>	300.5 kN	<b>67,555 lbf</b>
	<b>Two Speed Travel</b>					
Maximum Travel Speed at Rated RPM	Lo: 2.9 km/h	<b>1.8 mph</b>	4.85 km/h	<b>3.0 mph</b>	4.85 km/h	<b>3.0 mph</b>
	Hi: 4.6 km/h	<b>2.9 mph</b>				
Width of Standard Track Shoe	600 mm	<b>24"</b>	700 mm	<b>28"</b>	700 mm	<b>28"</b>
Overall Track Length	4590 mm	<b>15'1"</b>	5020 mm	<b>16'6"</b>	5020 mm	<b>16'6"</b>
Ground Contact Area with Std. Shoe	4.7 m <sup>2</sup>	<b>7350 in<sup>2</sup></b>	6.1 m <sup>2</sup>	<b>9500 in<sup>2</sup></b>	6.1 m <sup>2</sup>	<b>9500 in<sup>2</sup></b>
Track Gauge	2590 mm	<b>8'6"</b>	2590 mm	<b>8'6"</b>	2590 mm	<b>8'6"</b>
Fuel Tank Refill Capacity	620 L	<b>164 U.S. gal</b>	620 L	<b>163.79 U.S. gal</b>	620 L	<b>163.79 U.S. gal</b>
Hydraulic System (includes tank)	410 L	<b>108 U.S. gal</b>	410 L	<b>108.31 U.S. gal</b>	410 L	<b>108.31 U.S. gal</b>

\*Operating weight includes coolant, lubricants, full fuel tank, standard shoes, bucket and operator 75 kg (165 lb).

**NOTE:** Certain models may not be available in all Sales areas.

Specifications also vary by Sales area.

Contact your Cat dealer for details.

MODEL	336D2 XE		336D2 L XE		336E	
Region Offerings	China, S.E. Asia		S.E. Asia, South America, Africa, Middle East, CIS		Japan	
Engine Power:						
ISO 9249	208 kW	<b>279 hp</b>	208 kW	<b>279 hp</b>	224 kW	<b>300 hp</b>
SAE J1349	208 kW	<b>279 hp</b>	208 kW	<b>279 hp</b>	N/A	
Operating Weight*	37 000 kg	<b>81,600 lb</b>	37 000 kg	<b>81,600 lb</b>	34 500-37 200 kg	<b>76,059-82,012 lb</b>
Bucket Capacity Range (heaped)	0.73-2.78 m <sup>3</sup>	<b>0.95-3.64 yd<sup>3</sup></b>	0.73-2.78 m <sup>3</sup>	<b>0.95-3.64 yd<sup>3</sup></b>	1.4-2.0 m <sup>3</sup>	<b>1.8-2.6 yd<sup>3</sup></b>
Engine Model	C9 ACERT		C9 ACERT		C9.3 ACERT	
Emission Standards	Tier 3/Stage IIIA/Japan 2006 (Tier 3) Equivalent/China Nonroad Stage III		Tier 3/Stage IIIA/Japan 2006 (Tier 3) Equivalent		Japan 2011 (Tier 4 Interim) Equivalent	
Rated Engine RPM	1800		1800		1800	
No. of Cylinders	6		6		6	
Bore	112 mm	<b>4.41"</b>	112 mm	<b>4.41"</b>	—	
Stroke	149 mm	<b>5.87"</b>	149 mm	<b>5.87"</b>	—	
Displacement	8.8 L	<b>537 in<sup>3</sup></b>	8.8 L	<b>537 in<sup>3</sup></b>	9.3 L	<b>568 in<sup>3</sup></b>
Max. Implement Hydraulic Pump Output at Rated RPM	562 L/min	<b>148 gpm</b>	562 L/min	<b>148 gpm</b>	2 x 289 L/min	<b>2 x 76.5 gpm</b>
Relief Valve Settings:						
Implement Circuits	35 000 kPa	<b>5076 psi</b>	35 000 kPa	<b>5076 psi</b>	35 000 kPa	<b>5076 psi</b>
Travel Circuits	35 000 kPa	<b>5076 psi</b>	35 000 kPa	<b>5076 psi</b>	35 000 kPa	<b>5076 psi</b>
Swing Circuits	28 000 kPa	<b>4061 psi</b>	28 000 kPa	<b>4061 psi</b>	28 000 kPa	<b>4061 psi</b>
Pilot Circuits	4100 kPa	<b>595 psi</b>	4100 kPa	<b>595 psi</b>	4100 kPa	<b>595 psi</b>
Maximum Drawbar Pull	300 kN	<b>67,398 lbf</b>	300 kN	<b>67,398 lbf</b>	295 kN	<b>66,319 lbf</b>
	<b>Two Speed Travel</b>		<b>Two Speed Travel</b>			
Maximum Travel Speed at Rated RPM	Lo: 2.9 km/h	<b>1.8 mph</b>	Lo: 2.9 km/h	<b>1.8 mph</b>	5.0 km/h	<b>3.0 mph</b>
	Hi: 4.6 km/h	<b>2.9 mph</b>	Hi: 4.6 km/h	<b>2.9 mph</b>		
Width of Standard Track Shoe	600 mm	<b>24"</b>	700 mm	<b>28"</b>	700 mm	<b>2'4"</b>
Overall Track Length	4590 mm	<b>15'1"</b>	5020 mm	<b>16'6"</b>	4590 mm	<b>15'1"</b>
Ground Contact Area with Std. Shoe	4.74 m <sup>2</sup>	<b>7350 in<sup>2</sup></b>	6.14 m <sup>2</sup>	<b>9520 in<sup>2</sup></b>	5.53 m <sup>2</sup>	<b>8572 in<sup>2</sup></b>
Track Gauge	2590 mm	<b>8'6"</b>	2590 mm	<b>8'6"</b>	2590 mm	<b>8'6"</b>
Fuel Tank Refill Capacity	620 L	<b>164 U.S. gal</b>	620 L	<b>164 U.S. gal</b>	620 L	<b>163.8 U.S. gal</b>
Hydraulic System (includes tank)	410 L	<b>108 U.S. gal</b>	410 L	<b>108 U.S. gal</b>	380 L	<b>100.4 U.S. gal</b>
Hydraulic Tank	—		—		194 L	<b>51.2 U.S. gal</b>

\*Operating weight includes coolant, lubricants, full fuel tank, standard shoes, bucket and operator 75 kg (165 lb).

**NOTE:** Certain models may not be available in all Sales areas.

Specifications also vary by Sales area.

Contact your Cat dealer for details.

MODEL	336E L		336E LN		336E L H	
Region Offerings	North America, Europe, Japan		Europe		North America, Europe, Japan	
Engine Power:						
ISO 9249	224 kW	<b>300 hp</b>	224 kW	<b>300 hp</b>	230 kW	<b>308 hp</b>
SAE J1349	224 kW	<b>300 hp</b>	N/A		230 kW	<b>308 hp</b>
Operating Weight*	36 144- 38 686 kg	<b>79,682- 85,286 lb</b>	36 144- 38 686 kg	<b>79,682- 85,286 lb</b>	36 570- 39 370 kg	<b>80,617- 86,796 lb</b>
Bucket Capacity Range (heaped)	0.74-3.16 m <sup>3</sup> <b>1.0-4.13 yd<sup>3</sup></b>		1.18-2.41 m <sup>3</sup> <b>1.54-3.15 yd<sup>3</sup></b>		0.74-3.16 m <sup>3</sup> <b>1.0-4.13 yd<sup>3</sup></b>	
Engine Model	<b>C9.3 ACERT</b>		<b>C9.3 ACERT</b>		<b>C9.3 ACERT</b>	
Emission Standards	<b>Tier 4 Interim/Stage IIIB/ Japan 2011 (Tier 4 Interim) Equivalent</b>		<b>Stage IIIB Equivalent</b>		<b>Tier 4 Interim/Stage IIIB/ Japan 2011 (Tier 4 Interim) Equivalent</b>	
Rated Engine RPM	<b>1800</b>		<b>1800</b>		<b>1800</b>	
No. of Cylinders	<b>6</b>		<b>6</b>		<b>6</b>	
Displacement	9.3 L	<b>568 in<sup>3</sup></b>	9.3 L	<b>568 in<sup>3</sup></b>	9.3 L	<b>568 in<sup>3</sup></b>
Max. Implement Hydraulic Pump Output at Rated RPM	2 × 289 L/min	<b>2 × 76.5 gpm</b>	2 × 289 L/min	<b>2 × 76.5 gpm</b>	2 × 285 L/min	<b>2 × 75.3 gpm</b>
Relief Valve Settings:						
Implement Circuits	35 000 kPa	<b>5076 psi</b>	35 000 kPa	<b>5076 psi</b>	35 000 kPa	<b>5076 psi</b>
Travel Circuits	35 000 kPa	<b>5076 psi</b>	35 000 kPa	<b>5076 psi</b>	35 000 kPa	<b>5076 psi</b>
Swing Circuits	28 000 kPa	<b>4061 psi</b>	28 000 kPa	<b>4061 psi</b>	31 500 kPa	<b>4569 psi</b>
Pilot Circuits	4100 kPa	<b>595 psi</b>	4100 kPa	<b>595 psi</b>	4100 kPa	<b>595 psi</b>
Maximum Drawbar Pull	295 kN	<b>66,319 lbf</b>	295 kN	<b>66,319 lbf</b>	295 kN	<b>66,319 lbf</b>
Maximum Travel Speed at Rated RPM	4.9 km/h	<b>3.0 mph</b>	4.9 km/h	<b>3.0 mph</b>	4.9 km/h	<b>3.0 mph</b>
Width of Standard Track Shoe	850 mm	<b>2'10"</b>	600 mm	<b>2'0"</b>	850 mm	<b>2'10"</b>
Overall Track Length	5020 mm	<b>16'6"</b>	5020 mm	<b>16'6"</b>	5020 mm	<b>16'6"</b>
Ground Contact Area with Std. Shoe	7.46 m <sup>2</sup>	<b>11,563 in<sup>2</sup></b>	5.26 m <sup>2</sup>	<b>8153 in<sup>2</sup></b>	7.46 m <sup>2</sup>	<b>11,563 in<sup>2</sup></b>
Track Gauge	2590 mm	<b>8'6"</b>	2390 mm	<b>7'10"</b>	2590 mm	<b>8'6"</b>
Fuel Tank Refill Capacity	620 L	<b>163.8 U.S. gal</b>	620 L	<b>163.8 U.S. gal</b>	620 L	<b>163.8 U.S. gal</b>
Hydraulic System (includes tank)	380 L	<b>100.4 U.S. gal</b>	380 L	<b>100.4 U.S. gal</b>	380 L	<b>100.4 U.S. gal</b>
Hydraulic Tank	194 L	<b>51.2 U.S. gal</b>	194 L	<b>51.2 U.S. gal</b>	175 L	<b>44.9 U.S. gal</b>

\*Operating weight includes coolant, lubricants, full fuel tank, standard shoes, bucket and operator 75 kg (165 lb).

**NOTE:** Certain models may not be available in all Sales areas.

Specifications also vary by Sales area.  
Contact your Cat dealer for details.

MODEL	336E LN H		336F L		336F LN	
Region Offerings	Europe		North America		Europe	
Engine Power:						
ISO 9249	230 kW	<b>308 hp</b>	226 kW	<b>303 hp</b>	226 kW	<b>303 hp</b>
SAE J1349	N/A		N/A		226 kW	<b>303 hp</b>
Operating Weight*	35 400- 37 000 kg	<b>78,042- 81,569 lb</b>	36 500- 40 100 kg	<b>80,500- 88,400 lb</b>	38 900 kg	<b>85,800 lb</b>
Bucket Capacity Range (heaped)	1.18-2.41 m <sup>3</sup>	<b>1.54-3.15 yd<sup>3</sup></b>	0.74-3.16 m <sup>3</sup>	<b>1.0-4.13 yd<sup>3</sup></b>	0.73-2.55 m <sup>3</sup>	<b>0.95-3.33 yd<sup>3</sup></b>
Engine Model	C9.3 ACERT		C9.3 ACERT		C9.3 ACERT	
Emission Standards	Stage IIIB Equivalent		Tier 4 Final		Stage IV	
Rated Engine RPM	1800		1800		1800	
No. of Cylinders	6		6		6	
Bore	—		—		115 mm	<b>4.53"</b>
Stroke	—		—		149 mm	<b>5.87"</b>
Displacement	9.3 L	<b>568 in<sup>3</sup></b>	9.3 L	<b>568 in<sup>3</sup></b>	9.3 L	<b>567 in<sup>3</sup></b>
Max. Implement Hydraulic Pump Output at Rated RPM	2 x 285 L/min	<b>2 x 75.3 gpm</b>	2 x 289 L/min	<b>2 x 76.5 gpm</b>	570 L/min	<b>151 gpm</b>
Relief Valve Settings:						
Implement Circuits	35 000 kPa	<b>5076 psi</b>	35 000 kPa	<b>5076 psi</b>	35 000 kPa	<b>5076 psi</b>
Travel Circuits	35 000 kPa	<b>5076 psi</b>	35 000 kPa	<b>5076 psi</b>	35 000 kPa	<b>5076 psi</b>
Swing Circuits	31 500 kPa	<b>4569 psi</b>	28 000 kPa	<b>4061 psi</b>	28 000 kPa	<b>4061 psi</b>
Pilot Circuits	4100 kPa	<b>595 psi</b>	4100 kPa	<b>595 psi</b>	4100 kPa	<b>595 psi</b>
Maximum Drawbar Pull	295 kN	<b>66,319 lbf</b>	294 kN	<b>66,139 lbf</b>	294 kN	<b>66,139 lbf</b>
					<b>Two Speed Travel</b>	
Maximum Travel Speed at Rated RPM	4.9 km/h	<b>3.0 mph</b>	4.8 km/h	<b>3.0 mph</b>	Lo: 3.0 km/h	<b>1.9 mph</b>
					Hi: 4.8 km/h	<b>3.0 mph</b>
Width of Standard Track Shoe	600 mm	<b>2'0"</b>	850 mm	<b>2'10"</b>	600 mm	<b>24"</b>
Overall Track Length	5020 mm	<b>16'6"</b>	5030 mm	<b>16'6"</b>	5030 mm	<b>16'6"</b>
Ground Contact Area with Std. Shoe	5.26 m <sup>2</sup>	<b>8153 in<sup>2</sup></b>	7.46 m <sup>2</sup>	<b>11,563 in<sup>2</sup></b>	5.26 m <sup>2</sup>	<b>8150 in<sup>2</sup></b>
Track Gauge	2390 mm	<b>7'10"</b>	2590 mm	<b>8'6"</b>	2390 mm	<b>7'10"</b>
Fuel Tank Refill Capacity	620 L	<b>163.8 U.S. gal</b>	620 L	<b>164 U.S. gal</b>	620 L	<b>164 U.S. gal</b>
Hydraulic System (includes tank)	380 L	<b>100.4 U.S. gal</b>	380 L	<b>100 U.S. gal</b>	380 L	<b>100 U.S. gal</b>
Hydraulic Tank	175 L	<b>44.9 U.S. gal</b>	175 L	<b>46 U.S. gal</b>	—	

\*Operating weight includes coolant, lubricants, full fuel tank, standard shoes, bucket and operator 75 kg (165 lb).

**NOTE:** Certain models may not be available in all Sales areas.

Specifications also vary by Sales area.

Contact your Cat dealer for details.

MODEL	336F L XE		336F LN XE		340D2 L	
Region Offerings	North America, Europe		Europe		China, S.E. Asia, South America except Brazil, Africa, Middle East, CIS	
Engine Power:						
ISO 9249	226 kW	<b>303 hp</b>	226 kW	<b>303 hp</b>	208 kW	<b>279 hp</b>
SAE J1349	226 kW	<b>303 hp</b>	226 kW	<b>303 hp</b>	208 kW	<b>279 hp</b>
Operating Weight*	40 300 kg	<b>88,800 lb</b>	40 300 kg	<b>88,800 lb</b>	41 200 kg	<b>90,800 lb</b>
Bucket Capacity Range (heaped)	0.73-2.55 m <sup>3</sup>	<b>0.95-3.33 yd<sup>3</sup></b>	0.73-2.55 m <sup>3</sup>	<b>0.95-3.33 yd<sup>3</sup></b>	0.73-2.78 m <sup>3</sup>	<b>0.95-3.64 yd<sup>3</sup></b>
Engine Model	<b>C9.3 ACERT</b>		<b>C9.3 ACERT</b>		<b>C9 ACERT</b>	
Emission Standards	<b>Tier 4 Final/Stage IV</b>		<b>Stage IV</b>		<b>Tier 3/Stage IIIA/Japan 2006 (Tier 3) Equivalent/ China Nonroad Stage III</b>	
Rated Engine RPM	<b>1800</b>		<b>1800</b>		<b>1800</b>	
No. of Cylinders	<b>6</b>		<b>6</b>		<b>6</b>	
Bore	115 mm	<b>4.53"</b>	115 mm	<b>4.53"</b>	112 mm	<b>4.41"</b>
Stroke	149 mm	<b>5.87"</b>	149 mm	<b>5.87"</b>	149 mm	<b>5.87"</b>
Displacement	9.3 L	<b>567 in<sup>3</sup></b>	9.3 L	<b>567 in<sup>3</sup></b>	8.8 L	<b>537 in<sup>3</sup></b>
Max. Implement Hydraulic Pump Output at Rated RPM	570 L/min	<b>151 gpm</b>	570 L/min	<b>151 gpm</b>	562 L/min	<b>148 gpm</b>
Relief Valve Settings:						
Implement Circuits	35 000 kPa	<b>5076 psi</b>	35 000 kPa	<b>5076 psi</b>	35 000 kPa	<b>5076 psi</b>
Travel Circuits	35 000 kPa	<b>5076 psi</b>	35 000 kPa	<b>5076 psi</b>	35 000 kPa	<b>5076 psi</b>
Swing Circuits	31 500 kPa	<b>4569 psi</b>	31 500 kPa	<b>4569 psi</b>	28 000 kPa	<b>4061 psi</b>
Pilot Circuits	4100 kPa	<b>595 psi</b>	4100 kPa	<b>595 psi</b>	4100 kPa	<b>595 psi</b>
Maximum Drawbar Pull	294 kN	<b>66,139 lbf</b>	294 kN	<b>66,139 lbf</b>	300 kN	<b>67,398 lbf</b>
	<b>Two Speed Travel</b>		<b>Two Speed Travel</b>		<b>Two Speed Travel</b>	
Maximum Travel Speed at Rated RPM	Lo: 3.0 km/h	<b>1.9 mph</b>	Lo: 3.0 km/h	<b>1.9 mph</b>	Lo: 2.9 km/h	<b>1.8 mph</b>
	Hi: 4.8 km/h	<b>3.0 mph</b>	Hi: 4.8 km/h	<b>3.0 mph</b>	Hi: 4.6 km/h	<b>2.9 mph</b>
Width of Standard Track Shoe	850 mm	<b>33"</b>	600 mm	<b>24"</b>	600 mm	<b>24"</b>
Overall Track Length	5030 mm	<b>16'6"</b>	5030 mm	<b>16'6"</b>	5060 mm	<b>16'7"</b>
Ground Contact Area with Std. Shoe	7.46 m <sup>2</sup>	<b>11,560 in<sup>2</sup></b>	5.26 m <sup>2</sup>	<b>8150 in<sup>2</sup></b>	5.26 m <sup>2</sup>	<b>8150 in<sup>2</sup></b>
Track Gauge	2590 mm	<b>8'6"</b>	2390 mm	<b>7'10"</b>	2920 mm	<b>9'7"</b>
Fuel Tank Refill Capacity	620 L	<b>164 U.S. gal</b>	620 L	<b>164 U.S. gal</b>	620 L	<b>164 U.S. gal</b>
Hydraulic System (includes tank)	380 L	<b>100 U.S. gal</b>	380 L	<b>100 U.S. gal</b>	410 L	<b>108 U.S. gal</b>

\*Operating weight includes coolant, lubricants, full fuel tank, standard shoes, bucket and operator 75 kg (165 lb).

**NOTE:** Certain models may not be available in all Sales areas.

Specifications also vary by Sales area.  
Contact your Cat dealer for details.

MODEL	340F L		349D2		349D2 L	
Region Offerings	Europe		China, Asia Pacific, CIS		South America, China, Asia Pacific, Middle East, Africa, CIS	
Engine Power:						
ISO 9249	228 kW	<b>306 hp</b>	289 kW	<b>387 hp</b>	289 kW	<b>387 hp</b>
SAE J1349	228 kW	<b>306 hp</b>	N/A		N/A	
Operating Weight*	43 600 kg	<b>96,100 lb</b>	43 570- 46 580 kg	<b>96,055- 102,691 lb</b>	45 382- 47 919 kg	<b>100,100- 105,600 lb</b>
Bucket Capacity Range (heaped)	1.64-2.41 m <sup>3</sup>	<b>2.14-3.16 yd<sup>3</sup></b>	1.0-3.1 m <sup>3</sup>	<b>1.3-4.03 yd<sup>3</sup></b>	1.0-3.1 m <sup>3</sup>	<b>1.3-4.03 yd<sup>3</sup></b>
Engine Model	<b>C9.3 ACERT</b>		<b>C13 ACERT</b>		<b>C13 ACERT</b>	
Emission Standards	<b>Stage IV</b>		<b>Tier 2/Stage II Equivalent OR China Nonroad Stage III</b>		<b>Tier 2/Stage II Equivalent OR Tier 3/Stage IIIA Equivalent/ China Nonroad Stage III</b>	
Rated Engine RPM	<b>1800</b>		<b>1800</b>		<b>1800</b>	
No. of Cylinders	<b>6</b>		<b>6</b>		<b>6</b>	
Bore	115 mm	<b>4.53"</b>	—		—	
Stroke	149 mm	<b>5.87"</b>	—		—	
Displacement	9.3 L	<b>567 in<sup>3</sup></b>	12.5 L	<b>762 in<sup>3</sup></b>	12.5 L	<b>762 in<sup>3</sup></b>
Max. Implement Hydraulic Pump Output at Rated RPM	570 L/min	<b>151 gpm</b>	2 x 367 L/min	<b>2 x 97 gpm</b>	2 x 367 L/min	<b>2 x 97 gpm</b>
Relief Valve Settings:						
Implement Circuits	35 000 kPa	<b>5076 psi</b>	35 000 kPa	<b>5076 psi</b>	35 000 kPa	<b>5076 psi</b>
Travel Circuits	35 000 kPa	<b>5076 psi</b>	35 000 kPa	<b>5076 psi</b>	35 000 kPa	<b>5076 psi</b>
Swing Circuits	28 000 kPa	<b>4061 psi</b>	31 400 kPa	<b>4554 psi</b>	31 400 kPa	<b>4554 psi</b>
Pilot Circuits	4100 kPa	<b>595 psi</b>	4110 kPa	<b>596 psi</b>	4110 kPa	<b>596 psi</b>
Maximum Drawbar Pull	291 kN	<b>66,139 lbf</b>	338 kN	<b>75,985 lbf</b>	338 kN	<b>75,985 lbf</b>
	<b>Two Speed Travel</b>		<b>Two Speed Travel</b>		<b>Two Speed Travel</b>	
Maximum Travel Speed at Rated RPM	Lo: 3.0 km/h	<b>1.9 mph</b>	4.5 km/h	<b>2.7 mph</b>	Lo: 3.5 km/h	<b>2.2 mph</b>
	Hi: 4.8 km/h	<b>3.0 mph</b>			Hi: 4.5 km/h	<b>2.7 mph</b>
Width of Standard Track Shoe	600 mm	<b>24"</b>	750 mm	<b>2'6"</b>	600 mm	<b>24"</b>
Overall Track Length	5020 mm	<b>16'6"</b>	5070 mm	<b>16'8"</b>	5360 mm	<b>17'7"</b>
Ground Contact Area with Std. Shoe	5.26 m <sup>2</sup>	<b>8150 in<sup>2</sup></b>	6.6 m <sup>2</sup>	<b>10,200 in<sup>2</sup></b>	5.7 m <sup>2</sup>	<b>8800 in<sup>2</sup></b>
Track Gauge	2920 mm	<b>9'7"</b>	2740 mm	<b>9'0"</b>	2740 mm	<b>9'0"</b>
Fuel Tank Refill Capacity	620 L	<b>164 U.S. gal</b>	705 L	<b>186 U.S. gal</b>	705 L	<b>186 U.S. gal</b>
Hydraulic System (includes tank)	380 L	<b>100 U.S. gal</b>	570 L	<b>150 U.S. gal</b>	570 L	<b>150 U.S. gal</b>
Hydraulic Tank	—		243 L	<b>64 U.S. gal</b>	—	

\*Operating weight includes coolant, lubricants, full fuel tank, standard shoes, bucket and operator 75 kg (165 lb).

**NOTE:** Certain models may not be available in all Sales areas.

Specifications also vary by Sales area.

Contact your Cat dealer for details.

MODEL	349F L		349F L XE		352F	
Region Offerings	North America, Japan, Australia, New Zealand, South Korea		North America, Australia, New Zealand		North America, Europe, Japan	
Engine Power:						
ISO 9249	295 kW	396 hp	304 kW	408 hp	295 kW	396 hp
SAE J1349	N/A		304 kW	408 hp	N/A	
Operating Weight*	48 650-53 300 kg	107,200-117,500 lb	51 700 kg	114,000 lb	50 900-53 300 kg	112,200-117,500 lb
Bucket Capacity Range (heaped)	0.88-3.82 m <sup>3</sup>	1.15-5.0 yd <sup>3</sup>	0.88-3.82 m <sup>3</sup>	1.15-5.00 yd <sup>3</sup>	0.88-3.82 m <sup>3</sup>	1.15-5.0 yd <sup>3</sup>
Engine Model	C13 ACERT		C13 ACERT		C13 ACERT	
Emission Standards	Tier 4 Final/Stage IV/ Korea Tier 4/ Japan 2014 (Tier 4 Final)		Tier 4 Final/Stage IV		Tier 4 Final/Stage IV/ Japan 2014 (Tier 4 Final)	
Rated Engine RPM	1800		1800		1800	
No. of Cylinders	6		6		6	
Bore	—		130 mm	5.1"	—	
Stroke	—		157 mm	6.2"	—	
Displacement	12.5 L	763 in <sup>3</sup>	12.5 L	763 in <sup>3</sup>	12.5 L	763 in <sup>3</sup>
Max. Implement Hydraulic Pump Output at Rated RPM	2 x 385 L/min	2 x 102 gpm	750 L/min	198 gpm	2 x 385 L/min	2 x 102 gpm
Relief Valve Settings:						
Implement Circuits	35 000 kPa	5076 psi	35 000 kPa	5080 psi	35 000 kPa	5076 psi
Travel Circuits	35 000 kPa	5076 psi	35 000 kPa	5080 psi	35 000 kPa	5076 psi
Swing Circuits	27 500 kPa	3989 psi	27 500 kPa	3990 psi	27 500 kPa	3989 psi
Pilot Circuits	4120 kPa	598 psi	4120 kPa	598 psi	4120 kPa	598 psi
Maximum Drawbar Pull	335 kN	75,300 lbf	335 kN	75,300 lbf	335 kN	75,300 lbf
	<b>Two Speed Travel</b>		<b>Two Speed Travel</b>		<b>Two Speed Travel</b>	
Maximum Travel Speed at Rated RPM	Lo: 3.7 km/h	2.3 mph	Lo: 2.9 km/h	1.8 mph	Lo: 3.7 km/h	2.3 mph
	Hi: 4.7 km/h	2.9 mph	Hi: 4.7 km/h	2.9 mph	Hi: 4.7 km/h	2.9 mph
Width of Standard Track Shoe	900 mm	2'9"	900 mm	35"	900 mm	2'9"
Overall Track Length	5370 mm	17'7"	5370 mm	17'7"	5380 mm	17'8"
Ground Contact Area with Std. Shoe	8.48 m <sup>2</sup>	13,140 in <sup>2</sup>	7.89 m <sup>2</sup>	12,230 in <sup>2</sup>	8.45 m <sup>2</sup>	13,100 in <sup>2</sup>
Track Gauge	2740 mm	9'0"	2740 mm	9'0"	2890 mm	9'6"
Fuel Tank Refill Capacity	720 L	190 U.S. gal	720 L	190 U.S. gal	720 L	190 U.S. gal
Hydraulic System (includes tank)	570 L	150.6 U.S. gal	570 L	151 U.S. gal	570 L	150.6 U.S. gal
Hydraulic Tank	407 L	107.5 U.S. gal	—		407 L	107.5 U.S. gal

\*Operating weight includes coolant, lubricants, full fuel tank, standard shoes, bucket and operator 75 kg (165 lb).

NOTE: Certain models may not be available in all Sales areas.

Specifications also vary by Sales area.  
Contact your Cat dealer for details.



MODEL	352F XE		374F L		390F L	
Region Offerings	Europe		World Wide		World Wide	
Engine Power:						
ISO 9249	304 kW	<b>408 hp</b>	352 kW	<b>472 hp</b>	391 kW	<b>524 hp</b>
SAE J1349	304 kW	<b>408 hp</b>	352 kW	<b>472 hp</b>	391 kW	<b>524 hp</b>
Operating Weight*	54 600 kg	<b>120,400 lb</b>	70 973- 75 167 kg	<b>156,469- 165,714 lb</b>	86 033- 92 022 kg	<b>189,670- 202,874 lb</b>
Bucket Capacity Range (heaped)	0.88-3.82 m <sup>3</sup> <b>1.15-5.00 yd<sup>3</sup></b>		—		—	
Engine Model	<b>C13 ACERT</b>		<b>C15 ACERT</b>		<b>C18 ACERT</b>	
Emission Standards	<b>Stage IV</b>		<b>Tier 4 Final/Stage IV/ Japan 2014 (Tier 4 Final)</b> OR <b>Tier 3/Stage IIIA Equivalent/ China Nonroad Stage III</b> OR <b>Tier 2/Stage II Equivalent</b>		<b>Tier 4 Final/Stage IV/ Japan 2014 (Tier 4 Final)</b> OR <b>Tier 3/Stage IIIA Equivalent/ China Nonroad Stage III</b> OR <b>Tier 2/Stage II Equivalent</b>	
Rated Engine RPM	<b>1800</b>		<b>1600 (Operation) 1700 (Travel)</b>		<b>1700 (Operation) 1900 (Travel)</b>	
No. of Cylinders	<b>6</b>		<b>6</b>		<b>6</b>	
Bore	130 mm	<b>5.1"</b>	—		—	
Stroke	157 mm	<b>6.2"</b>	—		—	
Displacement	12.5 L	<b>763 in<sup>3</sup></b>	15.2 L	<b>928 in<sup>3</sup></b>	18.1 L	<b>1104.5 in<sup>3</sup></b>
Max. Implement Hydraulic Pump Output at Rated RPM	750 L/min	<b>198 gpm</b>	—		—	
Implement Travel	—	—	2 x 448 L/min	<b>2 x 118 gpm</b>	2 x 476 L/min	<b>2 x 133 gpm</b>
Relief Valve Settings:	—	—	2 x 476 L/min	<b>2 x 126 gpm</b>	2 x 532 L/min	<b>2 x 141 gpm</b>
Implement Circuits	35 000 kPa	<b>5080 psi</b>	37 000 kPa	<b>5366 psi</b>	35 000 kPa	<b>5076 psi</b>
Travel Circuits	35 000 kPa	<b>5080 psi</b>	35 000 kPa	<b>5076 psi</b>	35 000 kPa	<b>5076 psi</b>
Swing Circuits	27 500 kPa	<b>3990 psi</b>	35 000 kPa	<b>5076 psi</b>	35 000 kPa	<b>5076 psi</b>
Pilot Circuits	4120 kPa	<b>598 psi</b>	4.0-4.4 MPa	<b>580-638 psi</b>	4.0-4.4 MPa	<b>580-638 psi</b>
Maximum Drawbar Pull	335 kN	<b>75,300 lbf</b>	492 kN	<b>110,718 lbf</b>	590 kN	<b>132,637 lbf</b>
	<b>Two Speed Travel</b>		<b>Two Speed Travel</b>		<b>Two Speed Travel</b>	
Maximum Travel Speed at Rated RPM	Lo: 2.9 km/h	<b>1.8 mph</b>	Lo: 4.1 km/h	<b>2.6 mph</b>	Lo: 4.5 km/h	<b>2.8 mph</b>
	Hi: 4.7 km/h	<b>2.9 mph</b>	Hi: 4.1 km/h	<b>2.6 mph</b>	Hi: 4.5 km/h	<b>2.8 mph</b>
Width of Standard Track Shoe	600 mm	<b>24"</b>	650 mm	<b>2'1"</b>	650 mm	<b>2'1"</b>
Overall Track Length	5370 mm	<b>17'7"</b>	5870 mm	<b>19'3"</b>	6358 mm	<b>20'10"</b>
Ground Contact Area with Std. Shoe	5.26 m <sup>2</sup>	<b>8150 in<sup>2</sup></b>	6.65 m <sup>2</sup>	<b>10,300 in<sup>2</sup></b>	7.22 m <sup>2</sup>	<b>11,191 in<sup>2</sup></b>
Track Gauge (shipping)	2740 mm	<b>9'0"</b>	2750 mm	<b>9'0"</b>	2750 mm	<b>9'0"</b>
Extended (working position)	—	—	3400 mm	<b>11'2"</b>	3510 mm	<b>11.52'</b>
Fuel Tank Refill Capacity	720 L	<b>190 U.S. gal</b>	935 L	<b>247 U.S. gal</b>	1240 L	<b>328 U.S. gal</b>
Hydraulic System (includes tank)	570 L	<b>151 U.S. gal</b>	729 L	<b>193 U.S. gal</b>	997 L	<b>263 U.S. gal</b>
Hydraulic Tank	—	—	—	—	—	—

\*Operating weight includes coolant, lubricants, full fuel tank, boom, stick, bucket, operator 75 kg (**165 lb**) and standard shoes.

**NOTE:** Certain models may not be available in all Sales areas.

Specifications also vary by Sales area.  
Contact your Cat dealer for details.

## SHIPPING DIMENSIONS KEYS

### 300.9 through 390F L

---

- A Cab height
  - B House width, without mirrors
  - C Track width, standard shoe
  - D Ground clearance, frame
  - E Ground clearance, counterweight
  - F Tail swing radius
  - G Overall track length  
(grouser bar to grouser bar)
  - H Overall transport length
  - J Shipping height
  - K Length of track on ground
  - L Track gauge
- 

### M313D through M322F

---

- A Cab height
  - B Transport width
  - C Overall tire width
  - D Ground clearance, frame
  - E Transport length without boom
  - F Overall transport length
  - G Transport height
  - H Ground clearance, counterweight
  - J Tail swing radius
  - K Wheelbase length
  - L Overall width  
(outrigger to outrigger)
-

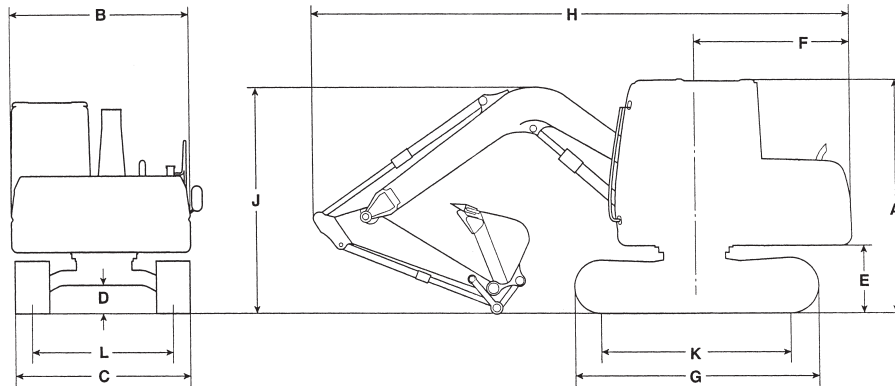

	<b>300.9D</b>		<b>301.4 C</b>		<b>301.7D</b>		<b>301.7D CR</b>		<b>302.2D</b>	
<b>Region Offerings</b>	North America, South America, Canada, Australia, New Zealand, Europe, Africa, Middle East		North America, Canada, Australia, New Zealand, Europe, Africa, Middle East		North America, South America, Canada, Australia, New Zealand, Europe, Africa, Middle East		North America, Canada, Australia, New Zealand, Europe, Africa, Middle East		Europe, Africa, Middle East	
	mm	ft	mm	ft	mm	ft	mm	ft	mm	ft
<b>A</b>	2276	7'6"	2276	7'6"	2290	7'5"	2362	7'9"	2295	7'6"
<b>B</b>	730	2'5"	990	3'2"	990	3'3"	730	2'5"	990	3'3"
<b>C</b>	711-864	2'4"-2'8"	990-1300	3'3"-4'3"	990-1300	3'3"-4'3"	990-1300	3'3"-4'3"	990-1300	3'3"-4'3"
<b>D</b>	—	—	—	—	—	—	—	—	—	—
<b>E</b>	—	—	—	—	—	—	—	—	—	—
<b>F</b>	747	2'5"	1075	3'5"	1169	3'10"	660	2'2"	1169	3'10"
<b>G</b>	1220	4'0"	1460	4'9"	1440	4'9"	1607	5'3"	1710	5'7"
<b>H*</b>	2746	9'0"	—	—	3810	12'8"	3584	11'9"	4027	13'3"
<b>J*</b>	—	—	—	—	2290	7'5"	2362	7'9"	2295	7'6"
<b>K</b>	—	—	—	—	—	—	—	—	—	—
<b>L</b>	531-864	1'9"-2'3"	760-1070	2'6"-3'6"	760-1070	2'6"-3'6"	760-1070	2'6"-3'6"	740-1050	2'5"-3'2"

\*Varies with stick length.

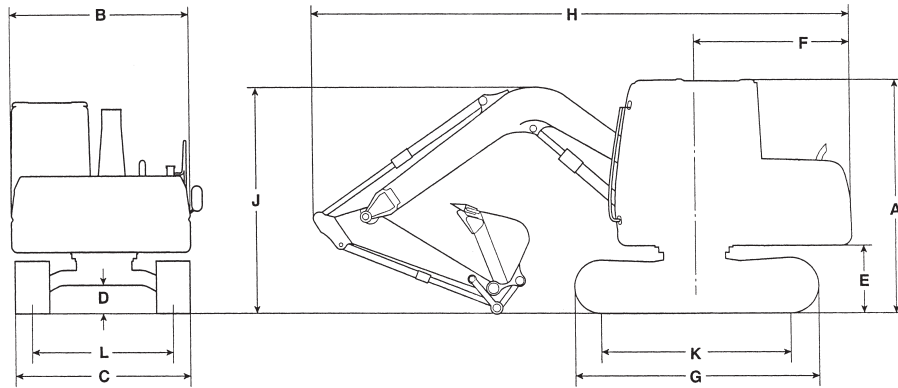

	<b>302.4D</b>		<b>302.7D CR</b>		<b>303E CR</b>		<b>303.5E CR</b>	
<b>Region Offerings</b>	North America, South America, Canada, Australia, New Zealand, Europe, Africa, Middle East		North America, South America, Canada, Australia, New Zealand, Europe, Africa, Middle East		North America, South America, Canada, Australia, New Zealand, Africa, Middle East		North America, South America, Canada, Australia, New Zealand, Africa, Middle East	
	mm	ft	mm	ft	mm	ft	mm	ft
<b>A</b>	2390	7'10"	2408	7'9"	2500	8'2"	2500	8'2"
<b>B</b>	1400	4'6"	1570	5'2"	1550	5'0"	1780	5'10"
<b>C</b>	1400	4'6"	1570	5'2"	1550	5'0"	1780	5'10"
<b>D</b>		—		—	317	1'0"	315	1'1"
<b>E</b>		—		—	575	1'10"	565	1'10"
<b>F</b>	1169	3'10"	760	2'5"	890	2'11"	890	2'11"
<b>G</b>	1840	6'0"	2006	6'6"	2210	7'3"	2220	7'3"
<b>H*</b>	4027	13'3"	4255	13'9"	4470	14'7"	4730	15'6"
<b>J*</b>	2390	7'10"	2408	7'9"	1590	5'3"	1420	4'8"
<b>K</b>		—		—	1640	5'4"	1760	5'10"
<b>L</b>	1150	3'8"	1270	4'2"	1250	4'0"	1480	4'10"

\*Varies with stick length.

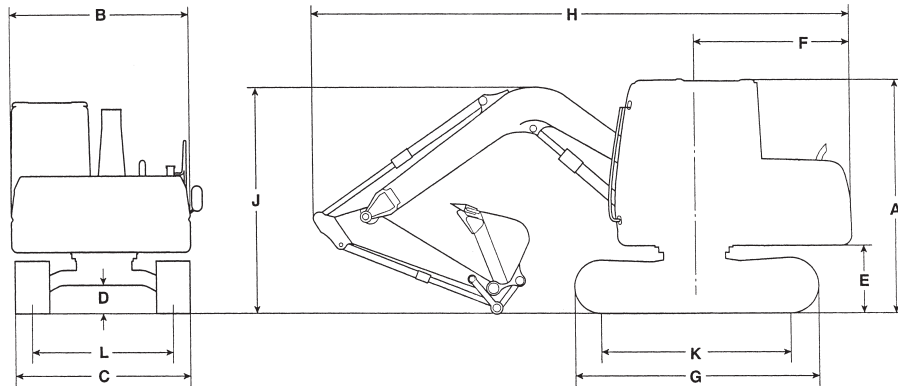

Region Offerings	303.5E2 CR		304E2 CR		304.5E2 XTC		305E2 CR	
	North America, South America, Canada, Australia, New Zealand, Europe, Africa, Middle East		North America, South America, Canada, Australia, New Zealand, Europe, Africa, Middle East		North America, Canada, Europe		North America, South America, Canada, Australia, New Zealand, Europe, Africa, Middle East	
	mm	ft	mm	ft	mm	ft	mm	ft
<b>A</b>	2500	8'2"	2500	8'2"	2500	8'2"	2550	8'4"
<b>B</b>	1780	5'10"	1950	6'5"	1950	6'5"	1980	6'6"
<b>C</b>	1780	5'10"	1950	6'5"	1950	6'5"	1980	6'6"
<b>D</b>	315	1'1"	310	1'0"	310	1'0"	340	1'1"
<b>E</b>	565	1'10"	565	1'10"	565	1'10"	615	2'0"
<b>F</b>	890	2'11"	975	3'2"	975	3'2"	1100	3'7"
<b>G</b>	2220	7'3"	2220	7'3"	2220	7'3"	2580	8'6"
<b>H*</b>	4730	15'6"	4820	15'10"	4820	15'10"	5180	17'0"
<b>J*</b>	1420	4'8"	1480	4'10"	1480	4'10"	1750	5'9"
<b>K</b>	1760	5'10"	1760	5'10"	1760	5'10"	2065	6'11"
<b>L</b>	1480	4'10"	1600	5'3"	1600	5'3"	1580	5'2"

\*Varies with stick length.

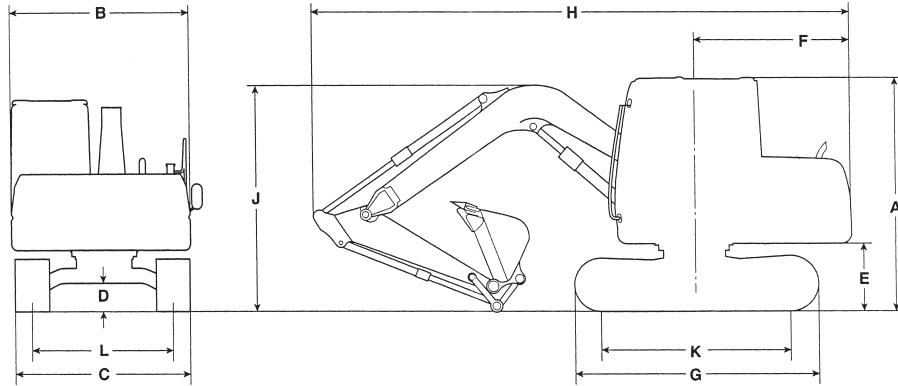

Region Offerings	305.5E2 CR		307E2		308E2 CR SB		308E2 VAB	
	North America, South America, Canada, Australia, New Zealand, Europe, Africa, Middle East		North America, Canada, Europe		North America, Canada, Australia, New Zealand, Europe		North America, Canada, Europe	
	mm	ft	mm	ft	mm	ft	mm	ft
<b>A</b>	2550	8'4"	2630	8'8"	2550	8'4"	2550	8'4"
<b>B</b>	1980	6'6"	2200	7'3"	2280	7'6"	2280	7'6"
<b>C</b>	1980	6'6"	2200	7'3"	2320	7'7"	2320	7'7"
<b>D</b>	340	1'1"	370	1'3"	384	1'3"	384	1'3"
<b>E</b>	615	2'0"	775	2'7"	735	2'5"	735	2'5"
<b>F</b>	1130	3'8"	1750	5'9"	1450	4'9"	1450	4'9"
<b>G</b>	2580	8'6"	2760	9'1"	2903	9'6"	2903	9'6"
<b>H*</b>	5330	17'6"	6080	19'11"	6380	20'11"	7010	23'0"
<b>J*</b>	1750	5'9"	2630	8'8"	2280	7'6"	2280	7'6"
<b>K</b>	2065	6'11"	2125	7'0"	2280	7'6"	2280	7'6"
<b>L</b>	1580	5'2"	1750	5'9"	1870	6'1"	1870	6'1"

\*Varies with stick length.

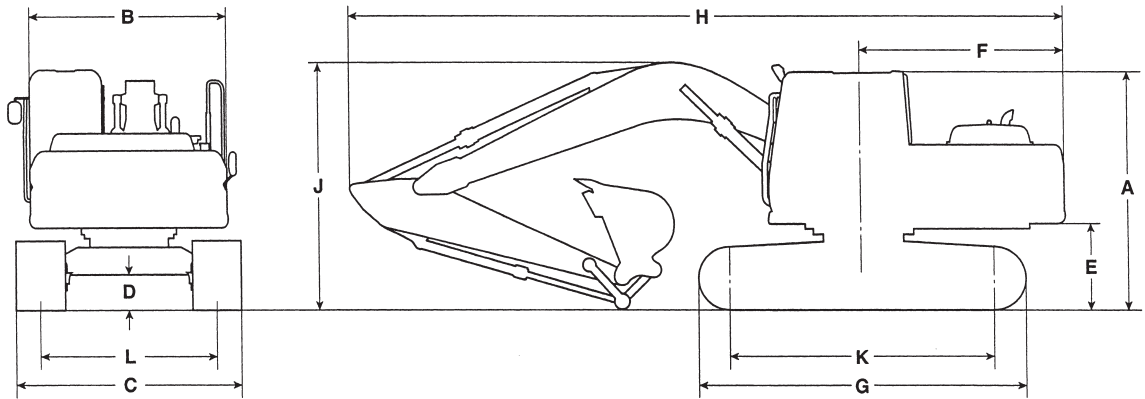

Region Offerings	311F L RR		312D2		312D2 GC		312D2 L	
	North America, Europe, Australia, New Zealand and Polynesia, Japan		Asia Pacific		China		Middle East, Africa, CIS, Asia Pacific, South America	
	mm	ft	mm	ft	mm	ft	mm	ft
<b>A</b>	2760	9'1"	2760	9'1"	2760	9'1"	2760	9'1"
<b>B</b>	2490	8'2"	2490	8'2"	2490	8'2"	2490	8'2"
<b>C</b>	2490	8'2"	2490	8'2"	2490	8'2"	2490	8'2"
<b>D</b>	440	17"	440	17"	440	17"	440	17"
<b>E</b>	910	3'0"	900	3'0"	900	3'0"	900	3'0"
<b>F</b>	1750	5'9"	2140	7'0"	2140	7'0"	2140	7'0"
<b>G</b>	3490	11'5"	3490	11'5"	3490	11'5"	3750	12'4"
<b>H*</b>	6910	22'8"	7610	25'0"	7610	25'0"	7610	25'0"
<b>J*</b>	2820	9'3"	2830	9'3"	2830	9'3"	2830	9'3"
<b>K</b>	2780	9'1"	2780	9'1"	2780	9'1"	3040	10'0"
<b>L</b>	1990	6'6"	1990	6'6"	1990	6'6"	1990	6'6"

\*Varies with stick length.

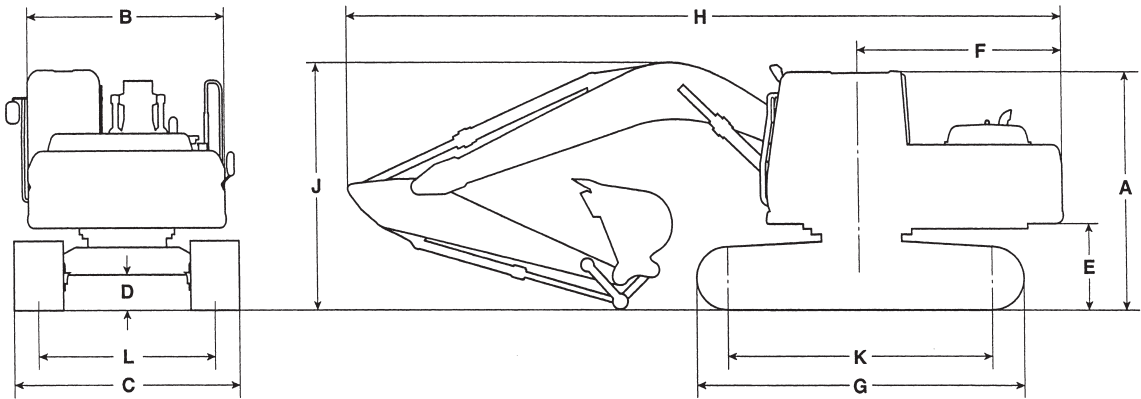

Region Offerings	312E		312E L		312E VA		312F GC		313D2	
	Europe, Australia, New Zealand and Polynesia, Japan		North America, Europe, Australia, New Zealand and Polynesia		Europe		Japan		China, Asia Pacific	
	mm	ft	mm	ft	mm	ft	mm	ft	mm	ft
<b>A</b>	2770	9'1"	2770	9'1"	2770	9'1"	2760	9'1"	2670	8'9"
<b>B</b>	2500	8'3"	2500	8'3"	2500	8'3"	2490	8'2"	2490	8'2"
<b>C</b>	2590	8'6"	2590	8'6"	2590	8'6"	2490	8'2"	2490	8'2"
<b>D</b>	440	17"	440	17"	440	17"	440	1'5"	440	17"
<b>E</b>	890	2'11"	890	2'11"	890	2'11"	900	2'11"	900	3'0"
<b>F</b>	2160	7'11"	2160	7'11"	2160	7'11"	2180	7'1"	2140	7'0"
<b>G</b>	3490	11'5"	3750	12'4"	3750	12'4"	3490	11'5"	3490	11'5"
<b>H*</b>	7680	25'2"	7670	25'2"	7730	25'4"	7680	25'2"	7610	25'0"
<b>J*</b>	2980	9'9"	2980	9'9"	2980	9'9"	2830	9'3"	2830	9'3"
<b>K</b>	2780	9'1"	3040	10'0"	3040	10'0"	2780	9'1"	2780	9'1"
<b>L</b>	1990	6'6"	1990	6'6"	1990	6'6"	1990	6'6"	1990	6'6"

\*Varies with stick length.



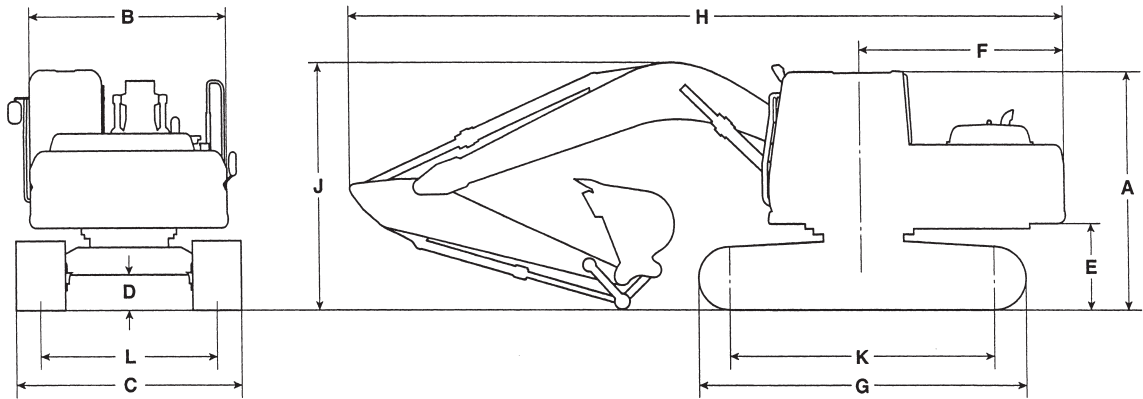

Region Offerings	313D2 LGP		313F L GC		314E CR		314E LCR		314E LCR VAB	
	Asia Pacific		North America, Europe, Turkey		Australia, New Zealand and Polynesia, Japan		North America, Europe, Australia, New Zealand and Polynesia, Japan		Europe	
	mm	ft	mm	ft	mm	ft	mm	ft	mm	ft
<b>A</b>	3150	10'4"	2760	9'1"	2810	9'3"	2810	9'3"	2810	9'3"
<b>B</b>	2490	8'2"	2490	8'2"	2490	8'2"	2490	8'2"	2490	8'2"
<b>C</b>	3040	10'0"	2490	8'2"	2490	8'2"	2490	8'2"	2490	8'2"
<b>D</b>	650	2'2"	440	1'5"	440	1'7"	440	1'7"	440	1'7"
<b>E</b>	1250	4'1"	900	2'11"	860	2'10"	860	2'10"	860	2'10"
<b>F</b>	2090	6'10"	2180	7'1"	1490	4'11"	1490	4'11"	1490	4'11"
<b>G</b>	4020	13'2"	3740	12'3"	3490	11'5"	3750	12'4"	3750	12'4"
<b>H*</b>	7600	24'11"	7700	25'3"	7610	25'0"	7610	25'0"	7580	24'10"
<b>J*</b>	3220	10'7"	2830	9'3"	3000	9'10"	3000	9'10"	3000	9'10"
<b>K</b>	3130	10'3"	3040	10'0"	2780	9'1"	3040	11'5"	3040	11'5"
<b>L</b>	2080	6'10"	1990	6'6"	1990	6'6"	1990	6'6"	1990	6'6"

\*Varies with stick length.

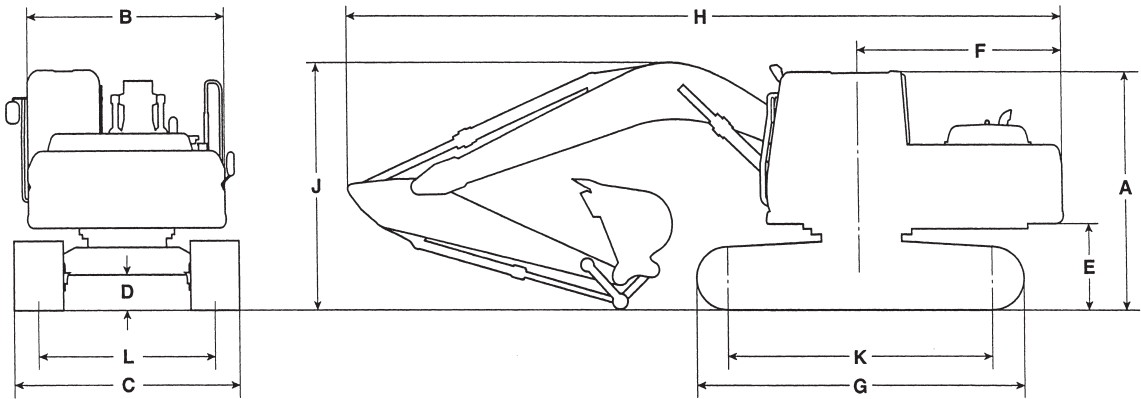

7

Region Offerings	316E L		316E L VA		318D2 L		318E L		318E L VA	
	North America, Europe, Australia, New Zealand and Polynesia, Japan		Europe		Middle East, Africa, CIS, South America, Asia Pacific, China		North America, Europe, Australia, New Zealand and Polynesia		Europe	
	mm	ft	mm	ft	mm	ft	mm	ft	mm	ft
<b>A</b>	2890	9'6"	2890	9'6"	2870	9'5"	2890	9'6"	2890	9'6"
<b>B</b>	2520	8'3"	2520	8'3"	2490	8'2"	2520	8'3"	2520	8'3"
<b>C</b>	2590	8'6"	2590	8'6"	2590	8'6"	2590	8'6"	2590	8'6"
<b>D</b>	440	1'5"	440	1'5"	460	1'6"	440	1'5"	440	1'5"
<b>E</b>	1010	3'4"	1010	3'4"	1000	3'3"	1010	3'4"	1010	3'4"
<b>F</b>	2500	8'2"	2500	8'2"	2500	8'2"	2500	8'2"	2500	8'2"
<b>G</b>	3970	13'0"	3970	13'0"	3970	13'0"	4075	13'4"	4075	13'4"
<b>H*</b>	8570	28'1"	8630	28'4"	8540	28'0"	8580	28'2"	8630	28'4"
<b>J*</b>	2980	9'9"	2980	9'9"	3030	9'11"	2980	9'9"	2980	9'9"
<b>K</b>	3170	10'5"	3170	10'5"	3170	10'5"	3265	10'9"	3265	10'9"
<b>L</b>	1990	6'6"	1990	6'6"	1990	6'6"	1990	6'6"	1990	6'6"

\*Varies with stick length.

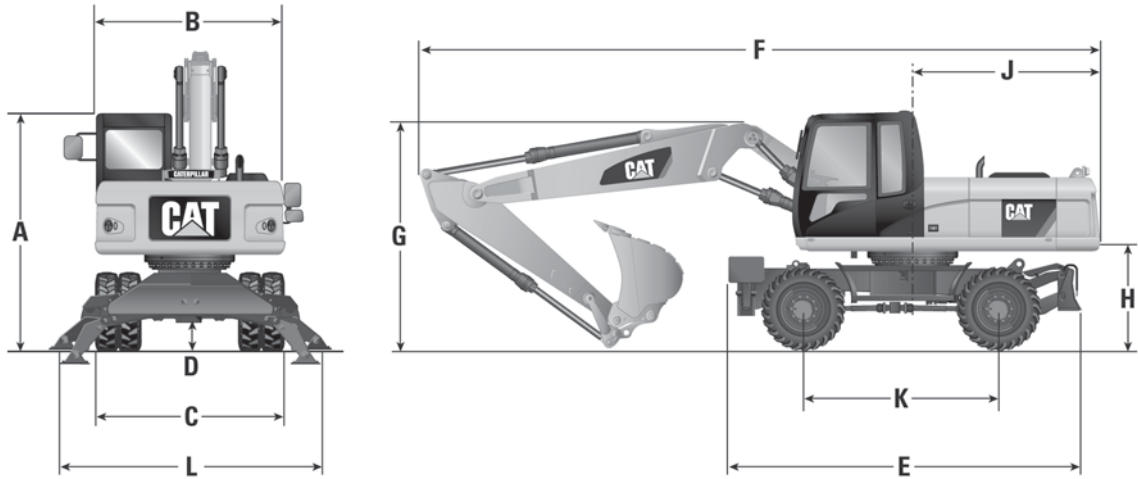

	<b>M313D†</b>		<b>M315D†</b>		<b>M315D2</b>		<b>M316D†</b>	
	<b>mm</b>	<b>ft</b>	<b>mm</b>	<b>ft</b>	<b>mm</b>	<b>ft</b>	<b>mm</b>	<b>ft</b>
<b>A</b>	3120	10'3"	3150	10'4"	3120	10'3"	3170	10'5"
<b>B</b>	2540	8'4"	2540	8'4"	2540	8'4"	2540	8'4"
<b>C*</b>	2550	8'4"	2550	8'4"	2550	8'4"	2550	8'4"
<b>Dozer width</b>	2540	8'4"	2550	8'4"	2540	8'4"	2550	8'4"
<b>D</b>	370	1'3"	370	1'3"	370	1'3"	370	1'3"
<b>E<sup>1</sup></b>	4755	15'7"	4805	15'9"	4755	15'7"	4825	15'10"
<b>E<sup>2</sup></b>	4965	16'3"	5015	16'5"	4965	16'3"	4860	15'11"
<b>E<sup>3</sup></b>	4355	14'3"	4405	14'5"	4355	14'3"	4330	14'2"
<b>F</b>	8080	26'6"	8330	27'4"	8080	26'6"	8400	27'7"
<b>G</b>	3120	10'3"	3150	10'4"	3120	10'3"	3170	10'5"
<b>H</b>	1240	4'1"	1260	4'2"	1240	4'1"	1280	4'2"
<b>J</b>	2076	6'10"	2215	7'3"	2076	6'10"	2290	7'6"
<b>K</b>	2500	8'2"	2550	8'4"	2500	8'2"	2600	8'6"
<b>L</b>	3645	12'0"	3645	12'0"	3645	12'0"	3675	12'1"

E<sup>1</sup> 2 Sets Outriggers.

E<sup>2</sup> Outriggers/Dozer.

E<sup>3</sup> Dozer only.

\*With standard tires 10.00-20 dual pneumatic.

†This product has been discontinued.

**NOTE:** Shipping dimensions above are for standard machine equipped with one-piece boom and medium stick.

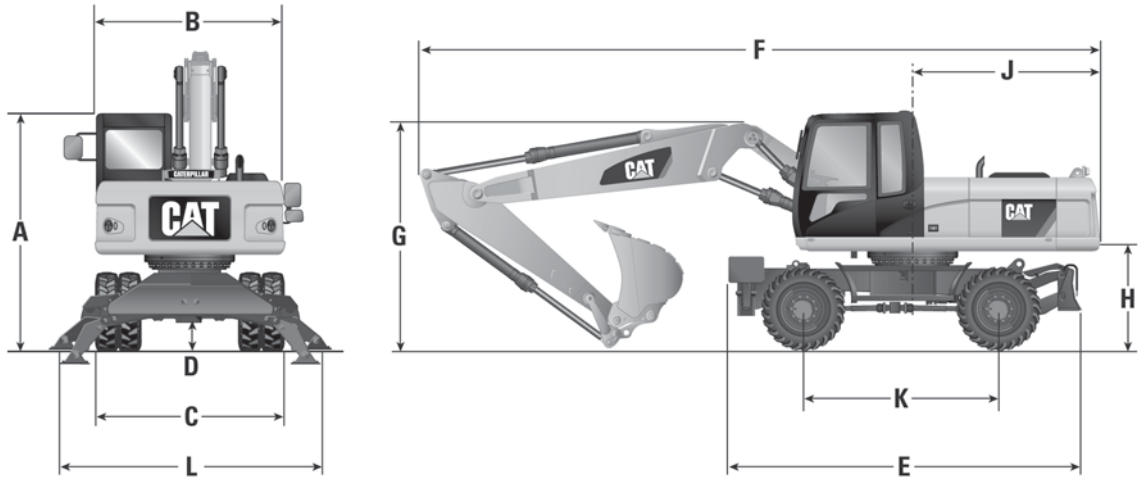

7

	M317D2		M318D†		M320D2		M322D†/M322D2	
	mm	ft	mm	ft	mm	ft	mm	ft
<b>A</b>	3150	10'4"	3170	10'5"	3170	10'5"	3200	10'6"
<b>B</b>	2540	8'4"	2540	8'4"	2540	8'4"	2670	8'9"
<b>C*</b>	2550	8'4"	2550	8'4"	2550	8'4"	2750	9'0"
<b>Dozer width</b>	2550	8'4"	2550	8'4"	2550	8'4"	2750	9'0"
<b>D</b>	370	1'3"	370	1'3"	370	1'3"	380	1'3"
<b>E<sup>1</sup></b>	4805	15'9"	4855	15'11"	4855	15'11"	5025	16'6"
<b>E<sup>2</sup></b>	5015	16'5"	4925	16'2"	4925	16'2"	5060	16'7"
<b>E<sup>3</sup></b>	4405	14'5"	4285	14'1"	4285	14'1"	4410	14'6"
<b>F</b>	8330	27'4"	8960	29'5"	8960	29'5"	9640	31'7"
<b>G</b>	3150	10'4"	3210	10'6"	3210	10'6"	3250	10'8"
<b>H</b>	1260	4'4"	1280	4'2"	1280	4'2"	1310	4'4"
<b>J</b>	2215	7'3"	2565	8'5"	2565	8'5"	2821	9'3"
<b>K</b>	2550	8'4"	2600	8'6"	2600	8'6"	2750	9'0"
<b>L</b>	3645	12'0"	3676	12'1"	3676	12'1"	3940	12'11"

E<sup>1</sup> 2 Sets Outriggers.  
 E<sup>2</sup> Outriggers/Dozer.  
 E<sup>3</sup> Dozer only.

\*With standard tires 10.00-20 dual pneumatic.

†This product has been discontinued.

**NOTE:** Shipping dimensions above are for standard machine equipped with one-piece boom and medium stick.

# Hydraulic Excavators

## Shipping Dimensions

● M314F ● M316F ● M318F ● M320F ● M322F

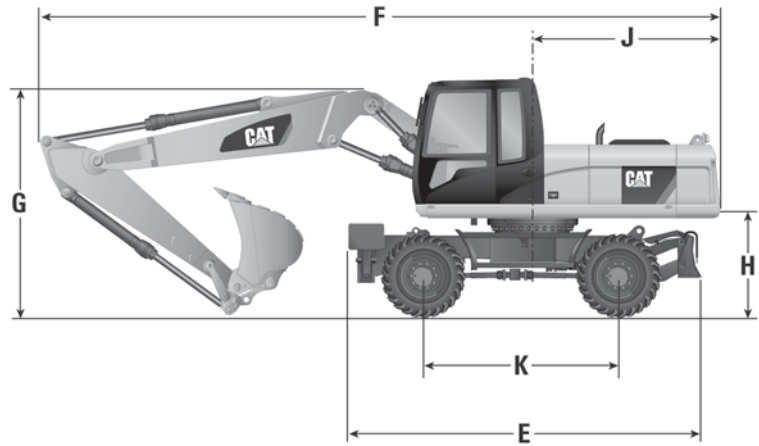
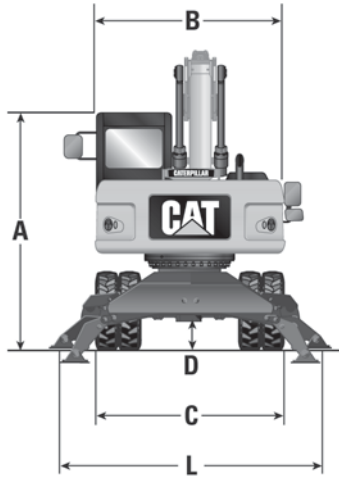

Linkage	M314F		M316F		M318F		M320F		M322F	
	mm	ft	mm	ft	mm	ft	mm	ft	mm	ft
<b>Hydraulically Adjustable Boom, Medium Stick</b>										
<b>A</b>	3150	10'4"	3170	10'5"	3190	10'6"	3190	10'6"	3220	10'7"
<b>B</b>	2540	8'4"	2540	8'4"	2540	8'4"	2540	8'4"	2670	8'9"
<b>C*</b>	2550	8'4"	2550	8'4"	2550	8'4"	2550	8'4"	2750	9'0"
<b>Dozer width</b>	2540	8'4"	2540	8'4"	2550	8'4"	2550	8'4"	2750	9'0"
<b>D</b>	370	1'3"	370	1'3"	370	1'3"	370	1'3"	380	1'3"
<b>E<sup>1</sup></b>	4710	15'5"	4805	15'9"	4855	15'11"	4855	15'11"	5040	16'6"
<b>E<sup>2</sup></b>	4920	16'2"	4970	16'4"	4950	16'3"	4950	16'3"	5190	17'0"
<b>E<sup>3</sup></b>	4310	14'2"	4360	14'4"	4380	14'4"	4380	14'4"	4500	14'9"
<b>F</b>	8455	27'9"	8640	28'4"	8610	28'3"	8850	29'0"	9555	31'4"
<b>G</b>	3150	10'4"	3170	10'5"	3190	10'6"	3190	10'6"	3220	10'7"
<b>H</b>	1240	4'1"	1260	4'2"	1280	4'2"	1280	4'2"	1310	4'4"
<b>J</b>	2090	6'10"	2220	7'3"	2300	7'7"	2570	8'5"	2825	9'3"
<b>K</b>	2500	8'2"	2550	8'4"	2600	8'6"	2600	8'6"	2750	9'0"
<b>L</b>	3645	11'11"	3645	11'11"	3680	12'1"	3680	12'1"	3930	12'11"

E<sup>1</sup> 2 Sets Outriggers.

E<sup>2</sup> Outriggers/Dozer.

E<sup>3</sup> Dozer only.

\*With standard tires 10.00-20 dual pneumatic.

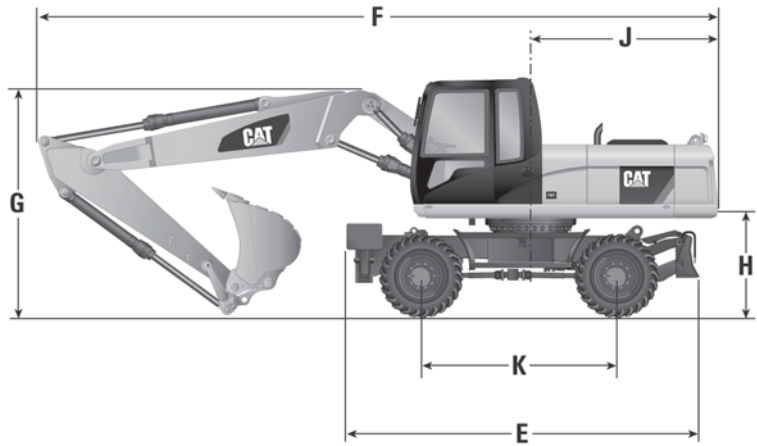
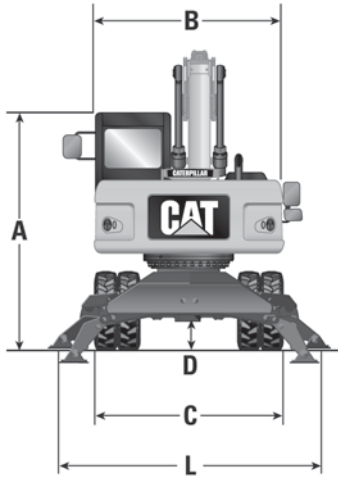

7

Linkage	M314F		M316F		M318F		M320F		M322F	
	mm	ft	mm	ft	mm	ft	mm	ft	mm	ft
	<b>One-piece Boom, Medium Stick</b>									
<b>A</b>	3150	10'4"	3170	10'5"	3190	10'6"	3190	10'6"	3220	10'7"
<b>B</b>	2540	8'4"	2540	8'4"	2540	8'4"	2540	8'4"	2670	8'9"
<b>C*</b>	2550	8'4"	2550	8'4"	2550	8'4"	2550	8'4"	2750	9'0"
<b>Dozer width</b>	2540	8'4"	2540	8'4"	2550	8'4"	2550	8'4"	2750	9'0"
<b>D</b>	370	1'3"	370	1'3"	370	1'3"	370	1'3"	380	1'3"
<b>E<sup>1</sup></b>	4710	15'5"	4805	15'9"	4855	15'11"	4855	15'11"	5040	16'6"
<b>E<sup>2</sup></b>	4920	16'2"	4970	16'4"	4950	16'3"	4950	16'3"	5190	17'0"
<b>E<sup>3</sup></b>	4310	14'2"	4360	14'4"	4380	14'4"	4380	14'4"	4500	14'9"
<b>F</b>	8250	27'1"	8490	27'10"	8460	27'9"	8960	29'5"	9710	31'10"
<b>G</b>	3150	10'4"	3170	10'5"	3190	10'6"	3190	10'6"	3220	10'7"
<b>H</b>	1240	4'1"	1260	4'2"	1280	4'2"	1280	4'2"	1310	4'4"
<b>J</b>	2090	6'10"	2220	7'3"	2300	7'7"	2570	8'5"	2825	9'3"
<b>K</b>	2500	8'2"	2550	8'4"	2600	8'6"	2600	8'6"	2750	9'0"
<b>L</b>	3645	11'11"	3645	11'11"	3680	12'1"	3680	12'1"	3930	12'11"

E<sup>1</sup> 2 Sets Outriggers.

E<sup>2</sup> Outriggers/Dozer.

E<sup>3</sup> Dozer only.

\*With standard tires 10.00-20 dual pneumatic.

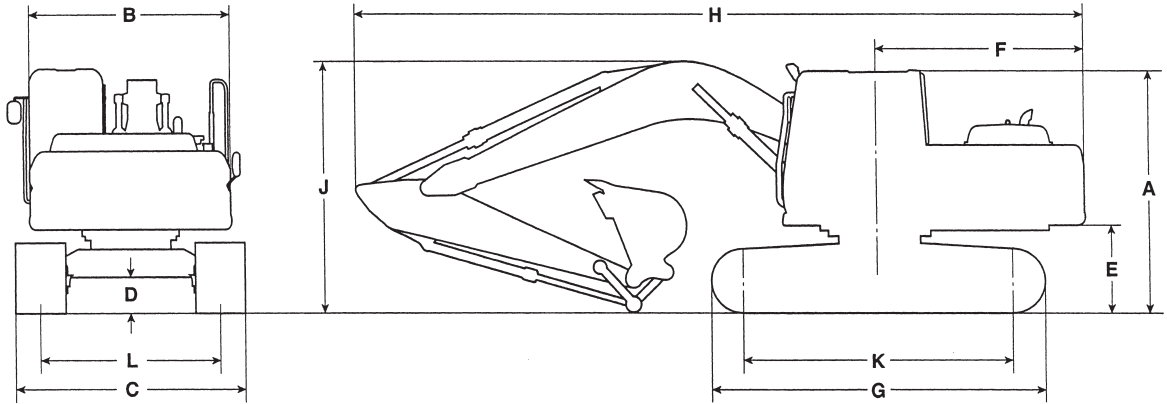

Region Offerings	320D2 Reach		320D2 GC Reach		320D2 L Reach		320E		320E L	
	Asia Pacific, China, Latin America		Africa, Middle East, CIS, Asia Pacific, China, Latin America		Africa, Middle East, Asia Pacific, China, Latin America		Japan		Japan	
	mm	ft	mm	ft	mm	ft	mm	ft	mm	ft
<b>A</b>	2950	9'8"	2950	9'8"	2950	9'8"	3150	10'3"	3150	10'3"
<b>B</b>	2740	9'0"	2740	9'0"	2740	9'0"	2770	9'1"	2770	9'1"
<b>C</b>	2990	9'10"	2800	9'2"	3170	10'5"	2800	9'2"	3170	10'5"
<b>D</b>	450	1'6"	450	1'6"	450	1'6"	450	1'6"	450	1'6"
<b>E</b>	1020	3'4"	1020	3'4"	1020	3'4"	1020	3'4"	1020	3'4"
<b>F</b>	2750	9'0"	2750	9'0"	2750	9'0"	2830	9'3"	2830	9'3"
<b>G</b>	4080	13'5"	4080	13'5"	4460	14'8"	4080	13'4"	4460	14'6"
<b>H*</b>	9460	31'0"	9460	31'0"	9460	31'0"	9530	31'3"	9340	30'8"
<b>J*</b>	3030	9'11"	3030	9'11"	3030	9'11"	3020	9'9"	3740	12'3"
<b>K</b>	3270	10'9"	3270	10'9"	3650	12'0"	3270	10'7"	3650	12'0"
<b>L</b>	2200	7'3"	2200	7'3"	2380	7'10"	2200	7'2"	2380	7'10"

\*Varies with stick length.

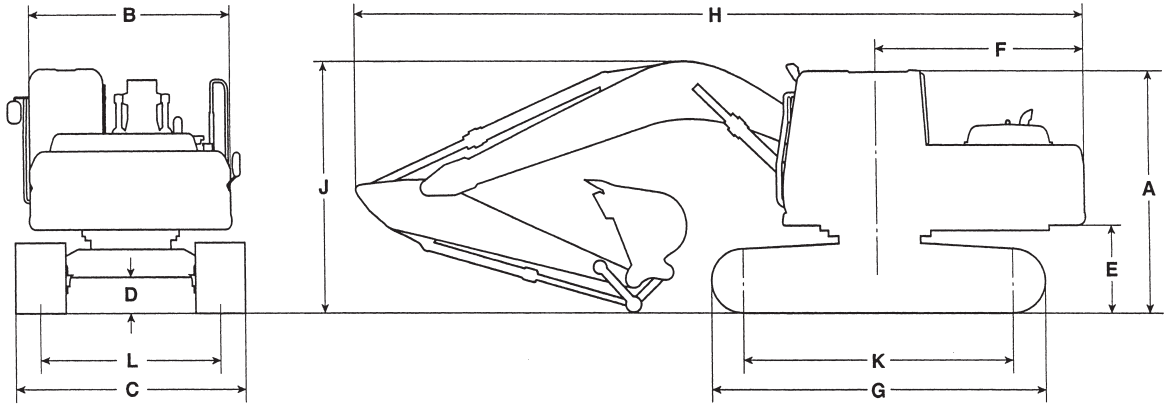

Region Offerings	320E L SLR		320E RR		320E LRR		320F L		320F L VA	
	Japan		Japan		North America		North America, Europe, Australia, New Zealand		Europe	
	mm	ft	mm	ft	mm	ft	mm	ft	mm	ft
<b>A</b>	3150	10'3"	3150	10'3"	3152	10'4"	3130	10'3"	3010	9'11"
<b>B</b>	2770	9'1"	2820	9'1"	2820	9'1"	2770	9'1"	2770	9'1"
<b>C</b>	3170	10'5"	3170	10'5"	3170	10'5"	3170	10'5"	3170	10'5"
<b>D</b>	450	1'6"	450	1'6"	450	1'6"	450	1'6"	450	1'6"
<b>E</b>	1020	3'4"	1000	3'3"	1000	3'3"	1020	3'4"	1020	3'4"
<b>F</b>	2830	9'3"	2080	6'8"	2080	6'8"	2830	7'10"	2830	9'3"
<b>G</b>	4460	14'6"	4455	14'7"	4455	14'7"	4460	14'8"	4450	14'7"
<b>H</b>	12 750	41'10"	8970	29'5"	8970	29'5"	9540	31'4"	9780	32'1"
<b>J*</b>	3180	10'4"	3150	10'4"	3150	10'4"	3130	10'3"	3010	9'11"
<b>K</b>	3650	12'0"	3270	10'7"	3650	12'0"	3650	12'0"	3650	12'0"
<b>L</b>	2380	7'10"	2200	7'2"	2380	7'10"	2380	7'10"	2380	7'10"

\*Varies with stick length.



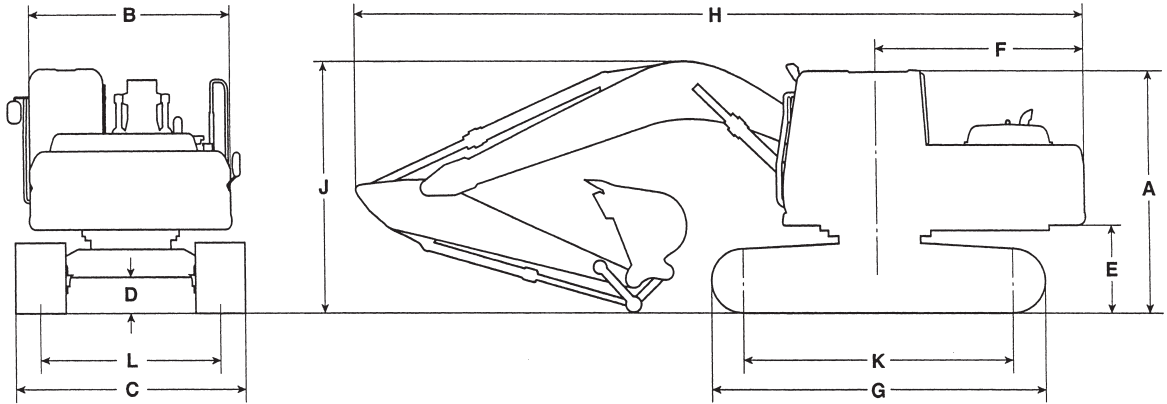

Region Offerings	323D2 L		323F L Reach		323F L VA		323F LN Reach		323F LN VA	
	Africa, Middle East, China, Latin America		North America, Europe, Australia, New Zealand		Europe		Europe		Europe	
	mm	ft	mm	ft	mm	ft	mm	ft	mm	ft
<b>A</b>	2950	9'8"	3010	9'11"	3010	9'11"	3020	9'11"	3000	9'10"
<b>B</b>	2490	8'2"	2770	9'1"	2770	9'1"	2540	8'4"	2540	8'4"
<b>C</b>	3170	10'5"	3170	10'5"	3170	10'5"	2500	8'2"	2500	8'2"
<b>D</b>	450	1'6"	450	1'6"	450	1'6"	450	1'6"	450	1'6"
<b>E</b>	1020	3'4"	1020	3'4"	1020	3'4"	1020	3'4"	1020	3'4"
<b>F</b>	2750	9'0"	2830	9'3"	2830	9'3"	2830	9'3"	2830	9'3"
<b>G</b>	4455	14'7"	4460	14'6"	4450	14'7"	4450	14'7"	4450	14'7"
<b>H*</b>	9460	31'0"	9540	31'4"	9780	32'1"	9560	31'4"	9820	32'3"
<b>J*</b>	3030	9'11"	3130	10'3"	3010	9'11"	3010	9'11"	3010	9'11"
<b>K</b>	3650	12'0"	3650	12'0"	3650	12'0"	3650	12'0"	3650	12'0"
<b>L</b>	2380	7'10"	2380	7'10"	2380	7'10"	2000	6'7"	2000	6'7"

\*Varies with stick length.

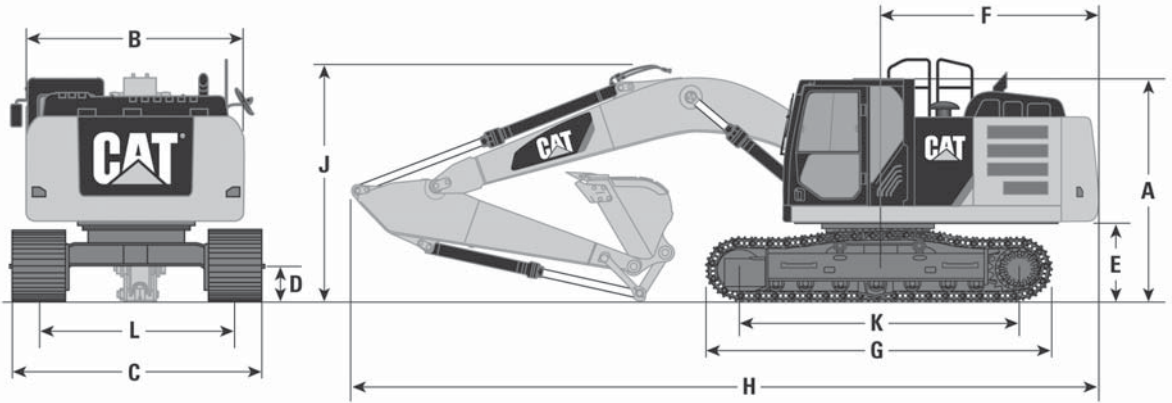

7

**325F L Reach**

**325F L VA**

Region Offerings	North America, Europe, Australia, New Zealand, Japan, Hong Kong, Taiwan		Europe	
	mm	ft	mm	ft
<b>A</b>	3060	10'0"	3060	10'0"
<b>B</b>	2980	9'9"	2980	9'9"
<b>C</b>	3170	10'5"	3170	10'5"
<b>D</b>	450	1'6"	450	1'6"
<b>E</b>	960	3'2"	960	3'2"
<b>F</b>	1720	5'8"	1720	5'8"
<b>G</b>	4460	14'8"	4460	14'8"
<b>H*</b>	8920	29'3"	9180	30'1"
<b>J*</b>	3180	10'5"	3140	10'4"
<b>K</b>	3650	12'0"	3650	12'0"
<b>L</b>	2380	7'10"	2380	7'10"

\*Varies with stick length.

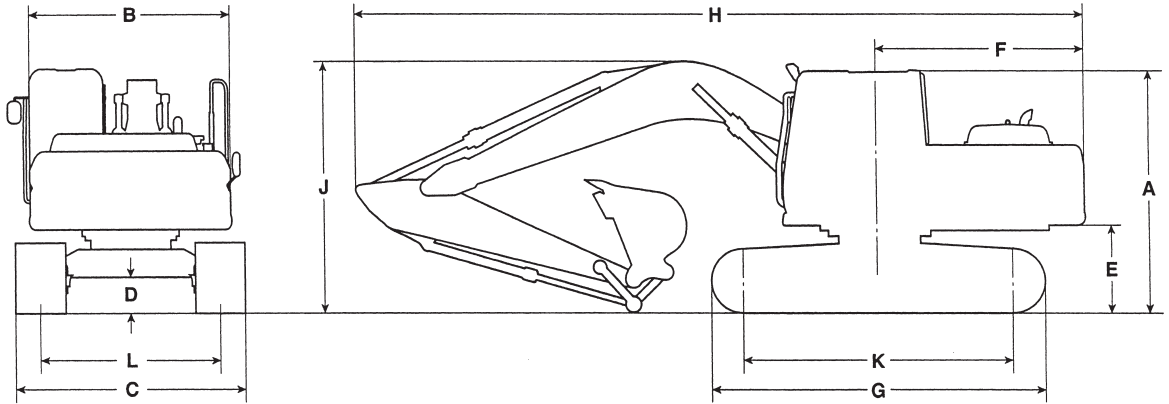

**326D2 L Reach**

Region Offerings	South America, Middle East, Africa, CIS, Asia Pacific, China	
	mm	ft
<b>A</b>	2980	9'9"
<b>B</b>	2900	9'6"
<b>C</b>	3380	11'1"
<b>D</b>	440	1'5"
<b>E</b>	1060	3'6"
<b>F</b>	3000	9'10"
<b>G</b>	4630	15'2"
<b>H*</b>	10 050	33'0"
<b>J*</b>	3170	10'5"
<b>K</b>	3830	12'7"
<b>L</b>	2590	8'6"

\*Varies with stick length.

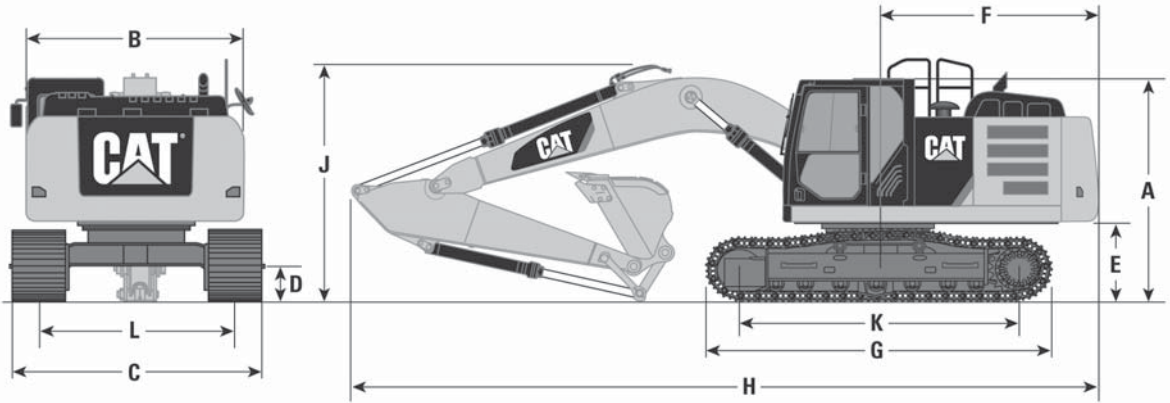

Region Offerings	326F L Reach		326F L VA		326F L SLR		326F LN Reach	
	Japan, North America, Europe, Australia, New Zealand		Europe		Japan, North America, Europe, Australia, New Zealand		Europe	
	mm	ft	mm	ft	mm	ft	mm	ft
<b>A</b>	2996	9'10"	2996	9'10"	2996	9'10"	2996	9'10"
<b>B</b>	2934	9'8"	2934	9'8"	2934	9'8"	2934	9'8"
<b>C</b>	3380	11'1"	3380	11'1"	3380	11'1"	2990	9'10"
<b>D</b>	440	1'5"	440	1'5"	440	1'5"	440	1'5"
<b>E</b>	1088	3'7"	1088	3'7"	1088	3'7"	1088	3'7"
<b>F</b>	2947	9'8"	2947	9'8"	2947	9'8"	2947	9'8"
<b>G</b>	4640	15'3"	4640	15'3"	4640	15'3"	4640	15'3"
<b>H*</b>	10 063	33'0"	10 200	33'6"	14 350	47'1"	10 063	33'0"
<b>J*</b>	3221	10'7"	3120	10'3"	3230	10'7"	3221	10'7"
<b>K</b>	3830	12'7"	3830	12'7"	3830	12'7"	3830	12'7"
<b>L</b>	2590	8'6"	2590	8'6"	2590	8'6"	2390	7'10"

\*Varies with stick length.

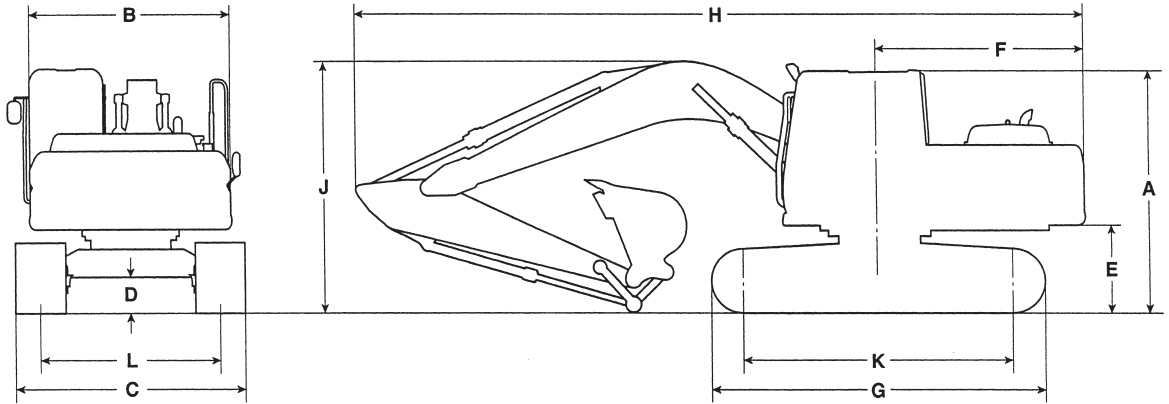

**330D2 L Reach**

Region Offerings	South America, Middle East, Africa, CIS, Asia Pacific, China	
	mm	ft
<b>A</b>	3040	10'0"
<b>B</b>	2900	9'6"
<b>C</b>	3390	11'1"
<b>D</b>	490	1'7"
<b>E</b>	1110	3'8"
<b>F</b>	3080	10'1"
<b>G</b>	4860	15'11"
<b>H*</b>	10 410	34'2"
<b>J*</b>	3180	10'5"
<b>K</b>	3990	13'1"
<b>L</b>	2590	8'6"

\*Varies with stick length.

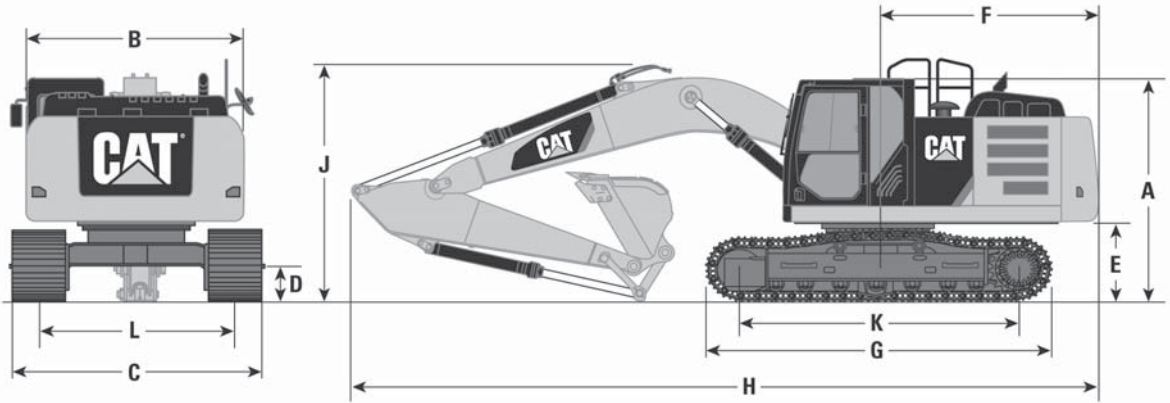

Region Offerings	330F L Reach		330F L SLR		330F LN Reach		335F L Reach**	
	Japan, North America, Europe, Australia, New Zealand, South Korea		North America		Europe		North America, Europe, Australia, New Zealand, Hong Kong, Taiwan	
	mm	ft	mm	ft	mm	ft	mm	ft
<b>A</b>	3044	10'0"	3044	10'0"	3044	10'0"	3260	10'8"
<b>B</b>	2934	9'8"	2934	9'8"	2930	9'8"	3540	11'7"
<b>C</b>	3190	10'6"	3190	10'6"	2990	9'10"	3440	11'3"
<b>D</b>	490	1'7"	490	1'7"	480	1'7"	480	1'7"
<b>E</b>	1134	3'9"	1134	3'9"	1134	3'9"	1200	3'11"
<b>F</b>	3044	10'0"	3044	10'0"	3044	10'0"	1900	6'3"
<b>G</b>	4860	15'11"	4860	15'11"	4855	15'11"	5020	16'6"
<b>H*</b>	10 386	34'1"	14 440	47'5"	10 386	34'1"	9820	32'3"
<b>J*</b>	3372	11'1"	3230	10'7"	3372	11'1"	3540	11'7"
<b>K</b>	3990	13'1"	3990	13'1"	3994	13'1"	4040	13'3"
<b>L</b>	2590	8'6"	2590	8'6"	2390	7'10"	2590	1'7"

\*Varies with stick length.

\*\*HD R3.2CB2 (10'6") stick and 850 mm (33") shoes.

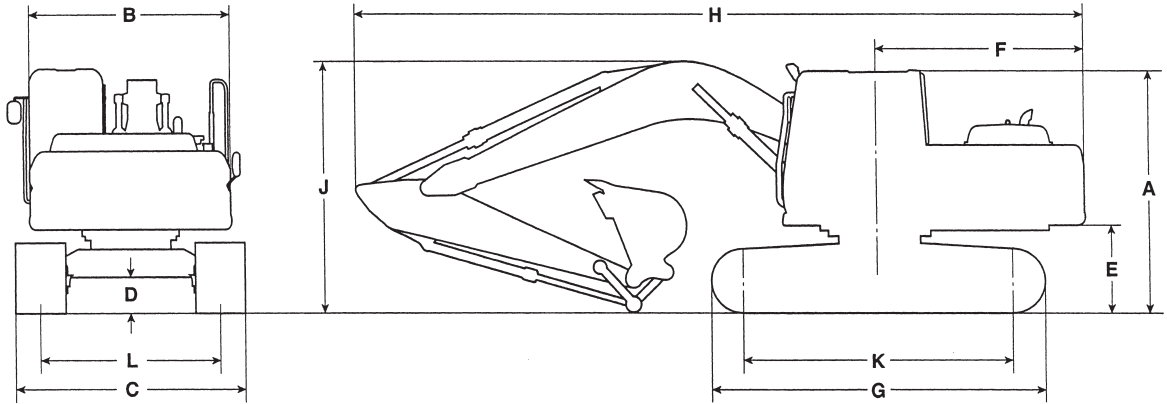

Region Offerings	336D2 Reach**		336D2 Mass**		336D2 L Reach		336D2 L Mass	
	Asia Pacific		Asia Pacific		Asia Pacific, South America, Middle East, Africa		Asia Pacific, South America, Middle East, Africa	
	mm	ft	mm	ft	mm	ft	mm	ft
<b>A</b>	3140	10'4"	3140	10'4"	3140	10'4"	3140	10'4"
<b>B</b>	2960	9'9"	2960	9'9"	2960	9'9"	2960	9'9"
<b>C</b>	3190	10'6"	3190	10'6"	3390	11'1"	3390	11'1"
<b>D</b>	450	1'6"	450	1'6"	450	1'6"	450	1'6"
<b>E</b>	1220	4'0"	1220	4'0"	1220	4'0"	1220	4'0"
<b>F</b>	3500	11'6"	3500	11'6"	3500	11'6"	3500	11'6"
<b>G</b>	4590	15'1"	4590	15'1"	5020	16'6"	5020	16'6"
<b>H*</b>	11 200	36'9"	10 910	35'10"	11 200	36'9"	10 910	35'10"
<b>J*</b>	3700	12'2"	3650	12'0"	3700	12'2"	3650	12'0"
<b>K</b>	3610	11'10"	3610	11'10"	4040	13'3"	4040	13'3"
<b>L</b>	2590	8'6"	2590	8'6"	2590	8'6"	2590	8'6"

\*Varies with stick length.

\*\*600 mm (24") shoes.

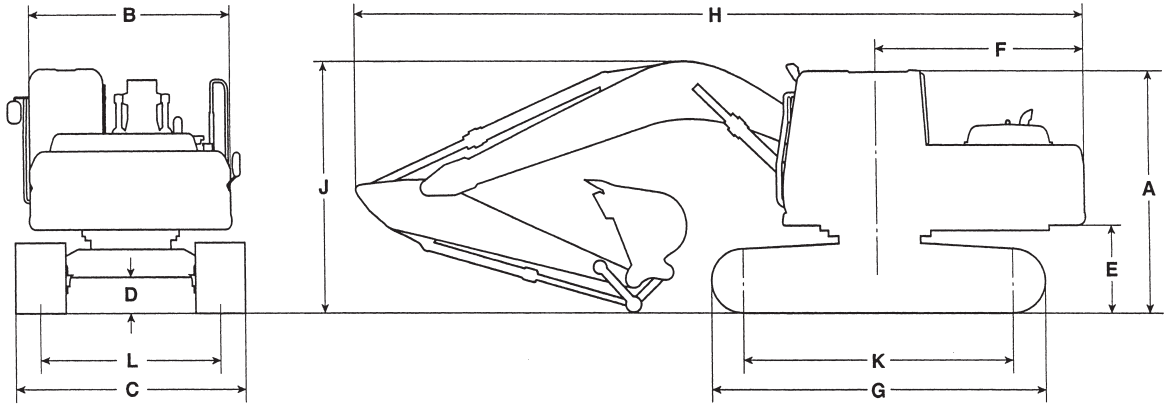

Region Offerings	336D2 GC**		336D2 XE**		336D2 L XE***	
	China		China, S.E. Asia		S.E. Asia, South America, Africa, Middle East, CIS	
	mm	ft	mm	ft	mm	ft
<b>A</b>	3140	10'4"	3140	10'4"	3140	10'4"
<b>B</b>	2960	9'6"	2960	9'6"	2960	9'6"
<b>C</b>	3190	10'6"	3190	10'6"	3290	10'10"
<b>D</b>	480	1'7"	480	1'7"	480	1'7"
<b>E</b>	1220	4'0"	1220	4'0"	1220	4'0"
<b>F</b>	3500	11'6"	3500	11'6"	3500	11'6"
<b>G</b>	4590	15'1"	4590	15'1"	5020	16'6"
<b>H*</b>	11 230	36'10"	10 890	35'9"	10 890	35'9"
<b>J*</b>	3640	11'11"	3600	11'10"	3600	11'10"
<b>K</b>	3610	11'10"	3610	11'10"	4040	13'3"
<b>L</b>	2590	8'6"	2590	8'6"	2590	8'6"

\*Varies with stick length.

\*\*R2.8 (9'2") stick and 600 mm (24") shoes.

\*\*\*M2.55 (8'4") stick and 700 mm (28") shoes.



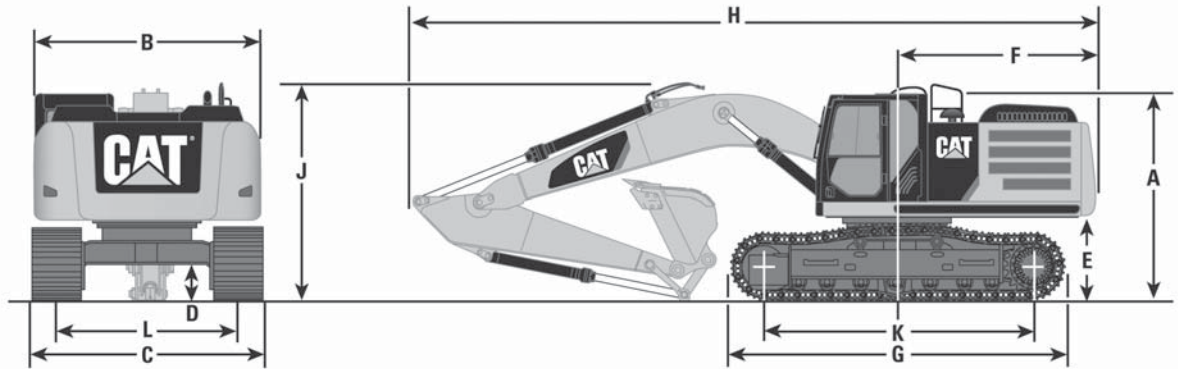

Region Offerings	336E Reach**		336E Mass***		336E L Reach****		336E L Mass*****	
	Japan		Japan		North America		North America	
	mm	ft	mm	ft	mm	ft	mm	ft
<b>A</b>	3360	11'0"	3360	11'0"	3360	11'0"	3360	11'0"
<b>B</b>	2982	9'8"	2982	9'8"	2982	9'8"	2982	9'8"
<b>C</b>	3190	10'6"	3190	10'6"	3440	11'3"	3440	11'3"
<b>D</b>	480	1'7"	480	1'7"	480	1'7"	480	1'7"
<b>E</b>	1220	4'0"	1220	4'0"	1220	4'0"	1220	4'0"
<b>F</b>	3460	11'4"	3460	11'4"	3460	11'4"	3460	11'4"
<b>G</b>	4590	15'1"	4590	15'1"	5020	16'6"	5020	16'6"
<b>H*</b>	11 160	36'7"	10 890	35'9"	11 170	36'8"	10 890	35'9"
<b>J*</b>	3510	11'6"	3600	11'10"	3660	12'0"	3600	11'10"
<b>K</b>	3605	11'10"	3605	11'10"	4040	13'3"	4040	13'3"
<b>L</b>	2590	8'6"	2590	8'6"	2590	8'6"	2590	8'6"

\*Varies with stick length.

\*\*R3.2 (10'6") stick and 600 mm (24") shoes.

\*\*\*M2.55 (8'4") stick and 600 mm (24") shoes.

\*\*\*\*R3.9 (12'10") stick and 850 mm (34") shoes.

\*\*\*\*\*M2.55 (8'4") stick and 850 mm (34") shoes.

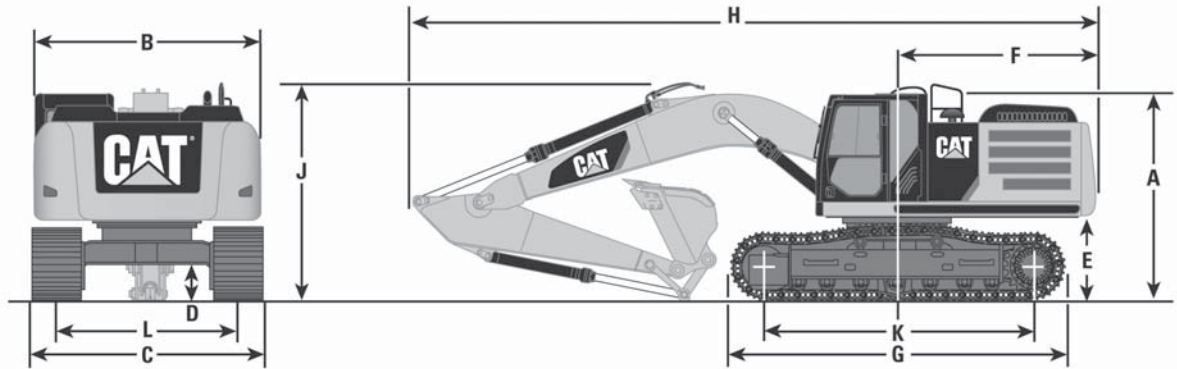

Region Offerings	336E L Reach**		336E L Mass***		336E LN Reach****		336E LN Mass*****	
	Europe		Europe		Europe		Europe	
	mm	ft	mm	ft	mm	ft	mm	ft
<b>A</b>	3360	11'0"	3360	11'0"	3360	11'0"	3360	11'0"
<b>B</b>	2982	9'8"	2982	9'8"	2982	9'8"	2982	9'8"
<b>C</b>	3290	10'10"	3290	10'10"	2990	9'10"	2990	9'10"
<b>D</b>	480	1'7"	480	1'7"	480	1'7"	480	1'7"
<b>E</b>	1220	4'0"	1220	4'0"	1220	4'0"	1220	4'0"
<b>F</b>	3460	11'4"	3460	11'4"	3460	11'4"	3460	11'4"
<b>G</b>	5020	16'6"	5020	16'6"	5020	16'6"	5020	16'6"
<b>H*</b>	11 160	36'7"	10 890	35'9"	11 160	36'7"	10 890	35'9"
<b>J*</b>	3510	11'6"	3600	11'10"	3510	11'6"	3600	11'10"
<b>K</b>	4040	13'3"	4040	13'3"	4040	13'3"	4040	13'3"
<b>L</b>	2590	8'6"	2590	8'6"	2390	7'10"	2390	7'10"

\*Varies with stick length.  
 \*\*R3.2 (10'6") stick and 700 mm (28") shoes.  
 \*\*\*M2.55 (8'4") stick and 700 mm (28") shoes.  
 \*\*\*\*R3.2 (10'6") stick and 600 mm (24") shoes.  
 \*\*\*\*\*M2.55 (8'4") stick and 600 mm (24") shoes.

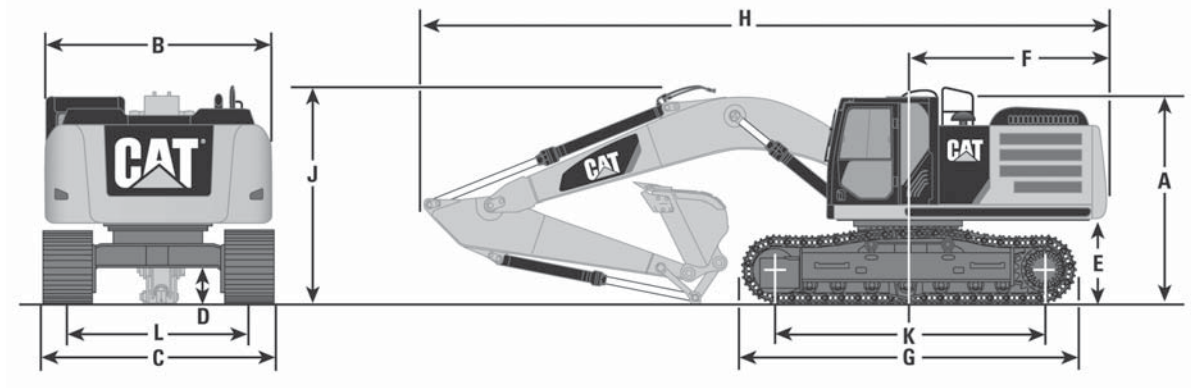

Region Offerings	336E L H Reach**		336E L H Reach***		336E LN H Reach****	
	North America		Europe, Japan		Europe	
	mm	ft	mm	ft	mm	ft
<b>A</b>	3360	11'0"	3360	11'0"	3360	11'0"
<b>B</b>	2982	9'8"	2982	9'8"	2982	9'8"
<b>C</b>	3440	11'3"	3290	10'10"	2990	9'10"
<b>D</b>	480	1'7"	480	1'7"	480	1'7"
<b>E</b>	1220	4'0"	1220	4'0"	1220	4'0"
<b>F</b>	3490	11'5"	3490	11'5"	3490	11'5"
<b>G</b>	5020	16'6"	5020	16'6"	5020	16'6"
<b>H*</b>	11 170	36'8"	11 160	36'7"	11 160	36'7"
<b>J*</b>	3660	12'0"	3510	11'6"	3510	11'6"
<b>K</b>	4040	13'3"	4040	13'3"	4040	13'3"
<b>L</b>	2590	8'6"	2590	8'6"	2390	7'10"

\*Varies with stick length.

\*\*R3.9 (12'10") stick and 850 mm (34") shoes.

\*\*\*R3.2 (10'6") stick and 700 mm (28") shoes.

\*\*\*\*R3.2 (10'6") stick and 600 mm (24") shoes.

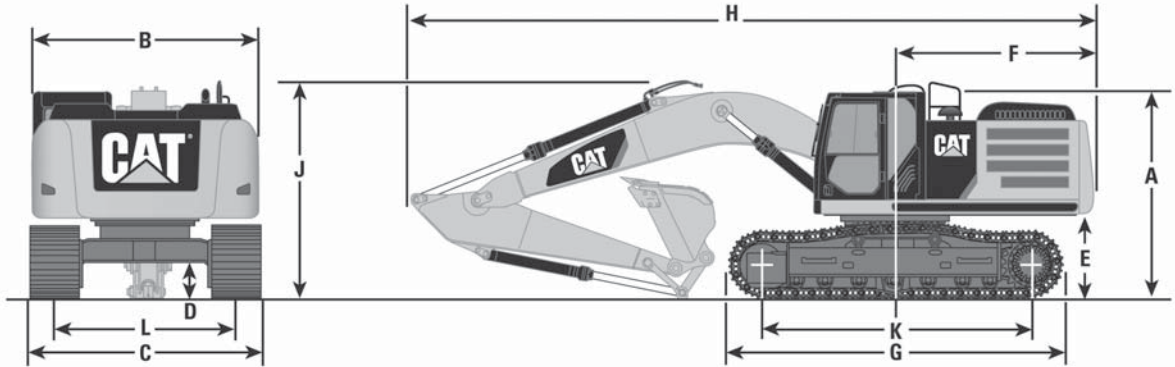

Region Offerings	336F L**		336F LN***		336F L XE**		336F LN XE***	
	North America		Europe		North America, Europe		Europe	
	mm	ft	mm	ft	mm	ft	mm	ft
<b>A</b>	3150	10'4"	3150	10'4"	3150	10'4"	3150	10'4"
<b>B</b>	2990	9'10"	2990	9'10"	2990	9'10"	2990	9'10"
<b>C</b>	3440	11'3"	2990	9'10"	3440	11'3"	2990	9'10"
<b>D</b>	480	1'7"	480	1'7"	480	1'7"	480	1'7"
<b>E</b>	1220	4'0"	1220	4'0"	1220	4'0"	1220	4'0"
<b>F</b>	3470	11'5"	3470	11'5"	3470	11'5"	3470	11'5"
<b>G</b>	5030	16'6"	5030	16'6"	5030	16'6"	5030	16'6"
<b>H*</b>	11 170	36'8"	11 160	36'7"	11 170	36'8"	11 160	36'7"
<b>J*</b>	3660	12'0"	3510	11'6"	3660	12'0"	3510	11'6"
<b>K</b>	4040	13'3"	4040	13'3"	4040	13'3"	4040	13'3"
<b>L</b>	2590	8'6"	2390	7'10"	2590	8'6"	2390	7'10"

\*Varies with stick length.  
 \*\*R3.9 (12'10") stick and 850 mm (33") shoes.  
 \*\*\*R3.2 (10'6") stick and 600 mm (24") shoes.

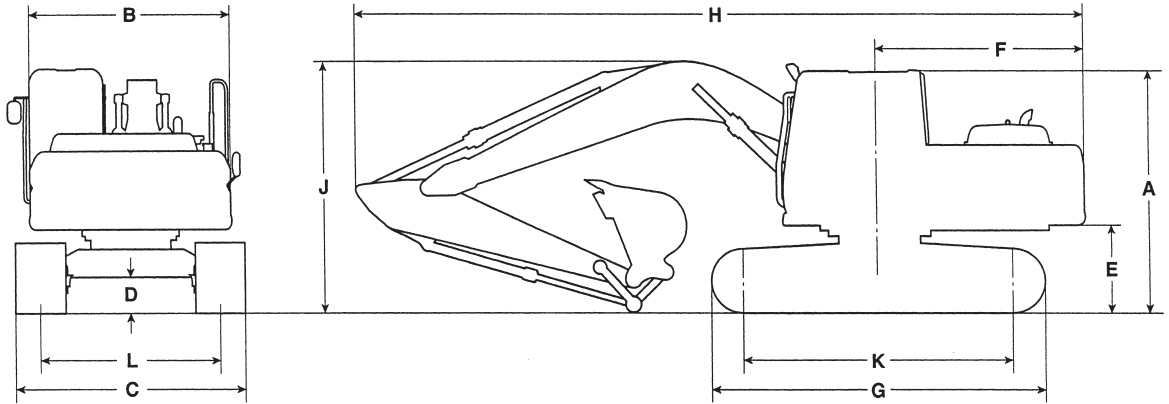

**340D2 L\*\***

Region Offerings	China, S.E. Asia, South America except Brazil, Africa, Middle East, CIS	
	mm	ft
<b>A</b>	3360	11'0"
<b>B</b>	2960	9'6"
<b>C</b>	3190	10'6"
<b>D</b>	690	2'3"
<b>E</b>	1450	4'9"
<b>F</b>	3490	11'5"
<b>G</b>	5060	16'7"
<b>H*</b>	10 900	35'9"
<b>J*</b>	3780	12'5"
<b>K</b>	4040	13'3"
<b>L</b>	2920	9'7"

\*Varies with stick length.

\*\*M2.55 (8'4") stick and 600 mm (24") shoes.

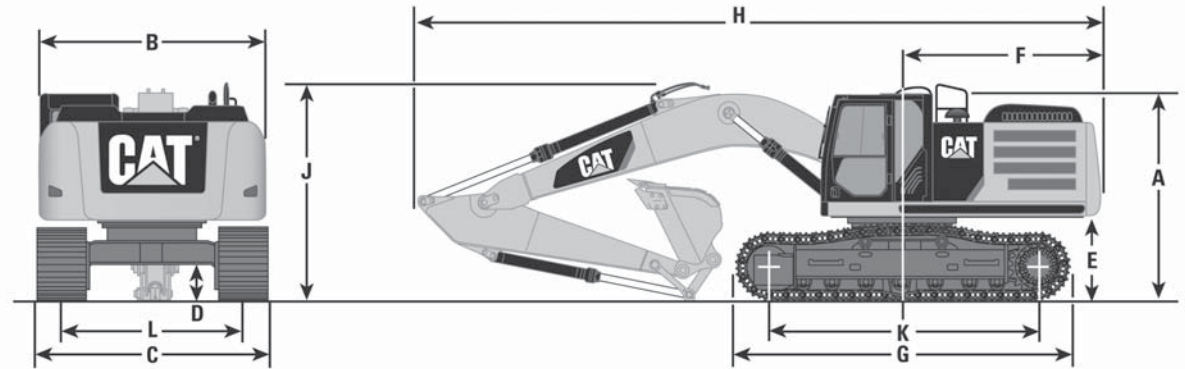

**340F L\*\***

Region Offerings	Europe	
	mm	ft
A	3390	11'1"
B	2990	9'10"
C	3520	11'7"
D	720	2'4"
E	1450	4'9"
F	3470	11'5"
G	5020	16'6"
H*	11 080	36'4"
J*	3450	11'4"
K	4040	13'3"
L	2920	9'7"

\*Varies with stick length.

\*\*R3.2 (10'6") stick and 600 mm (24") shoes.

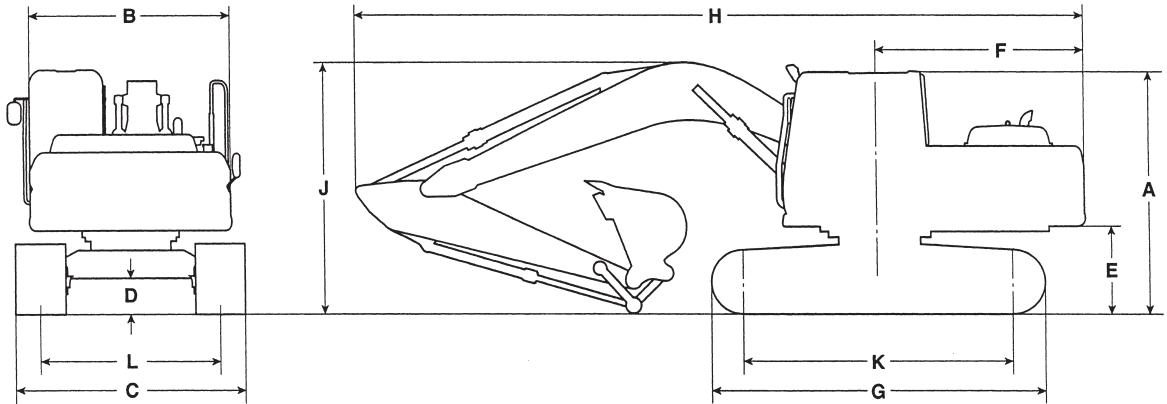

**349D2 Reach**

**349D2 L Mass**

Region Offerings	Asia Pacific, CIS		South America, Asia Pacific, Middle East, Africa, CIS, New Zealand, Australia	
	mm	ft	mm	ft
<b>A***</b>	3210	10'6"	3210	10'6"
<b>B****</b>	2962	9'8"	2962	9'8"
<b>C**</b>	3640	11'11"	3640	11'11"
<b>D</b>	510	1'8"	510	1'8"
<b>E</b>	1320	4'4"	1320	4'4"
<b>F</b>	3770	12'4"	3770	12'4"
<b>G</b>	5070	16'8"	5360	17'7"
<b>H*</b>	11 950	39'2"	11 710	38'5"
<b>J*</b>	3660	12'0"	3960	13'0"
<b>K</b>	4030	13'3"	4360	14'4"
<b>L</b>	2740	9'0"	2740	9'0"

\*Varies with stick length.

\*\*Transport position — 900 mm (36") track shoes.

\*\*\*Without Falling Object Guard (FOG).

\*\*\*\*No mirror or handrail.

Medium stick is available all models.

Undercarriage is retracted.

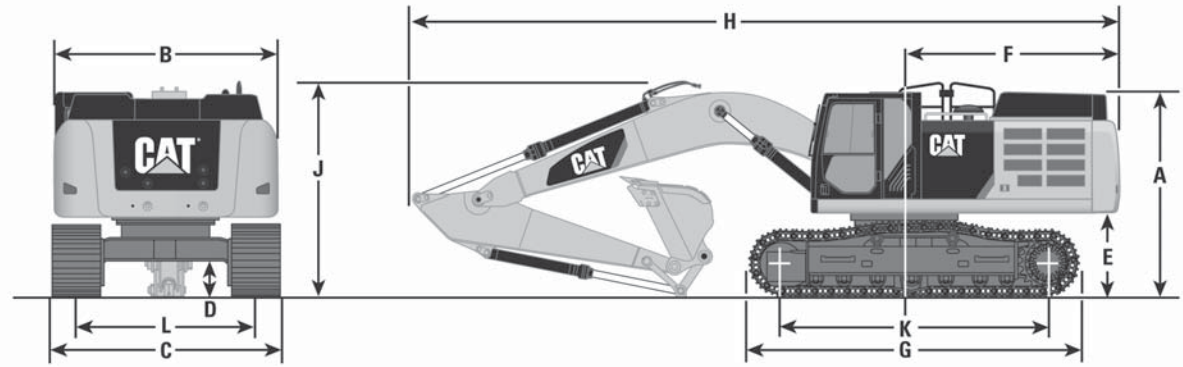

Region Offerings	349F L**		349F L***		349F L XE***	
	North America, Japan, New Zealand, Australia, South Korea		North America, Japan, New Zealand, Australia, South Korea		North America, New Zealand, Australia	
	mm	ft	mm	ft	mm	ft
A	3220	10'7"	3220	10'7"	3220	10'7"
B	2990	9'10"	3000	9'10"	2990	9'10"
C	3490	11'5"	3640	11'11"	3790	12'5"
D	480	1'7"	510	1'8"	480	1'7"
E	1280	4'2"	1280	4'2"	1280	4'2"
F	3760	12'4"	3760	12'4"	3760	12'4"
G	5370	17'7"	5370	17'7"	5370	17'7"
H*	11 920	39'1"	11 930	39'2"	11 930	39'2"
J*	3730	12'3"	3670	12'0"	3670	12'
K	4360	14'4"	4360	14'4"	4360	14'4"
L	2740	9'0"	2740	9'0"	2740	9'0"

\*Varies with stick length.

\*\*R3.35 (11'0") stick and 600 mm (24") shoes.

\*\*\*R3.9 (12'10") stick and 900 mm (35") shoes.



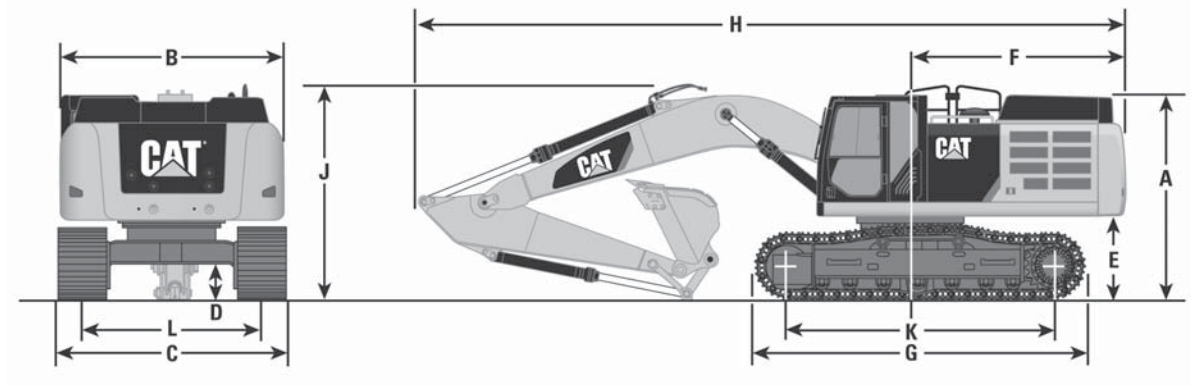

Region Offerings	352F**		352F***		352F XE****	
	North America, Europe, Japan		North America, Europe, Japan		Europe	
	mm	ft	mm	ft	mm	ft
<b>A</b>	3370	11'1"	3370	11'1"	3370	11'1"
<b>B</b>	2990	9'10"	3000	9'10"	2990	9'10"
<b>C</b>	3490	11'5"	3790	12'5"	3490	11'5"
<b>D</b>	710	2'4"	740	2'5"	710	2'4"
<b>E</b>	1430	4'8"	1430	4'8"	1430	4'8"
<b>F</b>	3760	12'4"	3760	12'4"	3760	12'4"
<b>G</b>	5380	12'8"	5380	17'8"	5380	12'8"
<b>H*</b>	11 820	38'9"	11 890	39'0"	11 640	38'2"
<b>J*</b>	3550	11'8"	3650	12'0"	4010	13'2"
<b>K</b>	4340	14'3"	4340	14'3"	4340	14'3"
<b>L</b>	2890	9'6"	2890	9'6"	2740	9'0"

\*Varies with stick length.

\*\*R3.35 (11'0") stick and 600 mm (24") shoes.

\*\*\*R3.9 (12'10") stick and 900 mm (35") shoes.

\*\*\*\*M2.5 (8'2") stick and 600 mm (24") shoes.

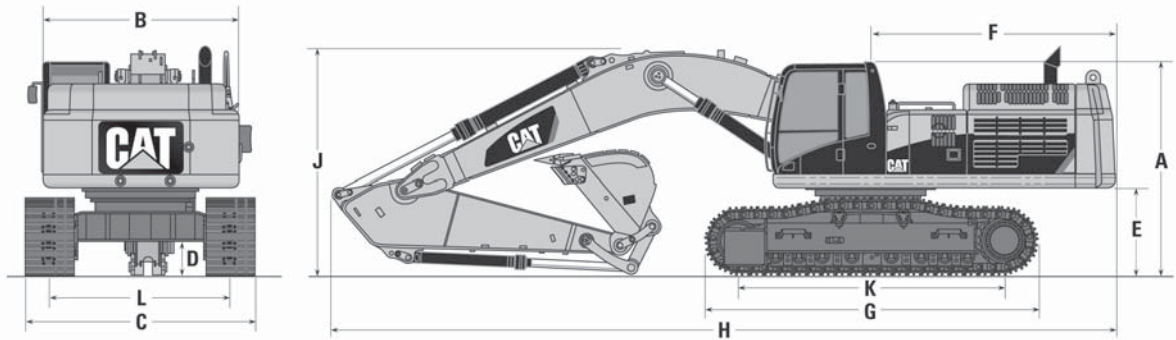

Region Offerings	374F L Reach**		374F L Reach***		374F L Reach****		374F L Reach*****		374F L Mass*****		374F L Mass*****	
	World Wide		World Wide		World Wide		World Wide		World Wide		World Wide	
	mm	ft	mm	ft	mm	ft	mm	ft	mm	ft	mm	ft
<b>A</b>	3970	13'0"	3970	13'0"	3970	13'0"	3970	13'0"	3970	13'0"	3970	13'0"
<b>B</b>	3450	11'4"	3450	11'4"	3450	11'4"	3450	11'4"	3450	11'4"	3450	11'4"
<b>C</b>	4340	14'3"	4340	14'3"	4340	14'3"	4340	14'3"	4340	14'3"	4340	14'3"
<b>D</b>	840	2'9"	840	2'9"	840	2'9"	840	2'9"	840	2'9"	840	2'9"
<b>E</b>	1540	5'1"	1540	5'1"	1540	5'1"	1540	5'1"	1540	5'1"	1540	5'1"
<b>F</b>	4015	13'2"	4015	13'2"	4015	13'2"	4015	13'2"	4015	13'2"	4015	13'2"
<b>G</b>	5870	19'3"	5870	19'3"	5870	19'3"	5870	19'3"	5870	19'3"	5870	19'3"
<b>H*</b>	13 230	43'5"	13 310	43'8"	13 330	43'9"	13 430	44'1"	12 620	41'5"	12 660	41'6"
<b>J*</b>	4990	16'5"	4650	15'3"	4520	14'10"	4300	14'1"	4720	15'6"	4630	15'2"
<b>K</b>	4705	15'5"	4705	15'5"	4705	15'5"	4705	15'5"	4705	15'5"	4705	15'5"
<b>L</b>	3410	11'2"	3410	11'2"	3410	11'2"	3410	11'2"	3410	11'2"	3410	11'2"

\*Varies with stick length.

\*\*R4.67 (15'4") stick and 900 mm (35") shoe with 3.8 m<sup>3</sup> (5.0 yd<sup>3</sup>) bucket.

\*\*\*R4.15 (13'7") stick and 900 mm (35") shoe with 3.8 m<sup>3</sup> (5.0 yd<sup>3</sup>) bucket.

\*\*\*\*R3.6 (11'10") stick and 900 mm (35") shoe with 3.8 m<sup>3</sup> (5.0 yd<sup>3</sup>) bucket.

\*\*\*\*\*R2.84 (9'4") stick and 900 mm (35") shoe with 3.8 m<sup>3</sup> (5.0 yd<sup>3</sup>) bucket.

\*\*\*\*\*M3.00 (9'10") stick and 650 mm (26") shoe with 4.6 m<sup>3</sup> (6.0 yd<sup>3</sup>) bucket.

\*\*\*\*\*M2.57 (8'5") stick and 650 mm (26") shoe with 4.6 m<sup>3</sup> (6.0 yd<sup>3</sup>) bucket.

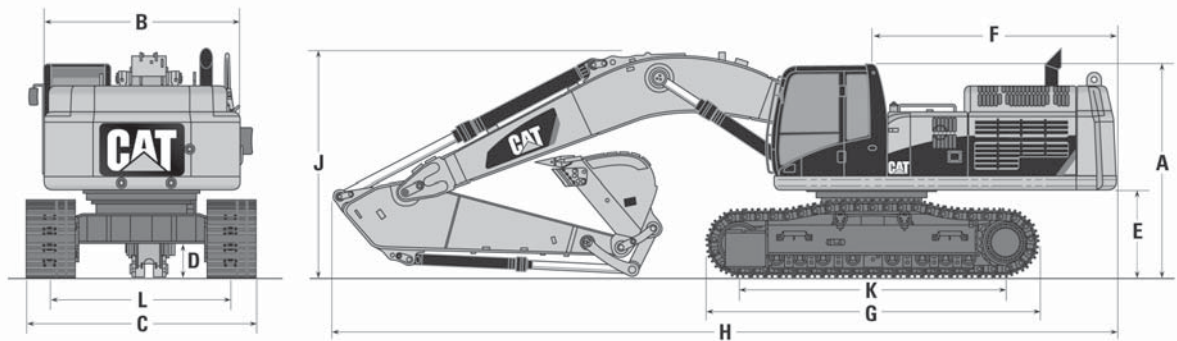

Region Offerings	390F L Reach**		390F L Reach***		390F L GP****		390F L GP*****		390F L GP*****	
	World Wide		World Wide		World Wide		World Wide		Japan	
	mm	ft	mm	ft	mm	ft	mm	ft	mm	ft
<b>A</b>	3830	12'7"	3830	12'7"	3830	12'7"	3830	12'7"	3830	12'7"
<b>B</b>	3470	11'5"	3470	11'5"	3470	11'5"	3470	11'5"	3470	11'5"
<b>C</b>	4260	14'0"	4260	14'0"	4260	14'0"	4260	14'0"	4260	14'0"
<b>D</b>	900	2'11"	900	2'11"	900	2'11"	900	2'11"	900	2'11"
<b>E</b>	1640	5'5"	1640	5'5"	1640	5'5"	1640	5'5"	1640	5'5"
<b>F</b>	4700	15'5"	4700	15'5"	4700	15'5"	4700	15'5"	4700	15'5"
<b>G</b>	6360	20'10"	6360	20'10"	6360	20'10"	6360	20'10"	6360	20'10"
<b>H*</b>	16 290	53'5"	16 330	53'7"	14 500	47'7"	14 690	48'2"	14 710	48'3"
<b>J*</b>	5490	18'0"	5070	16'8"	5840	19'2"	5290	17'4"	5080	16'8"
<b>K</b>	5120	16'10"	5120	16'10"	5120	16'10"	5120	16'10"	5120	16'10"
<b>L</b>	3510	11'6"	3510	11'6"	3510	11'6"	3510	11'6"	3510	11'6"

\*Varies with stick length.

\*\*R5.5 (18'1") stick and 750 mm (30") shoe with 3.9 m<sup>3</sup> (5.1 yd<sup>3</sup>) bucket.

\*\*\*R4.4 (14'5") stick and 750 mm (30") shoe with 3.9 m<sup>3</sup> (5.1 yd<sup>3</sup>) bucket.

\*\*\*\*R5.5 (18'1") stick and 750 mm (30") shoe with 4.6 m<sup>3</sup> (6.0 yd<sup>3</sup>) bucket.

\*\*\*\*\*R4.4 (14'5") stick and 750 mm (30") shoe with 4.6 m<sup>3</sup> (6.0 yd<sup>3</sup>) bucket.

\*\*\*\*\*GP3.7 (12'2") stick and 750 mm (30") shoe with 4.6 m<sup>3</sup> (6.0 yd<sup>3</sup>) bucket.

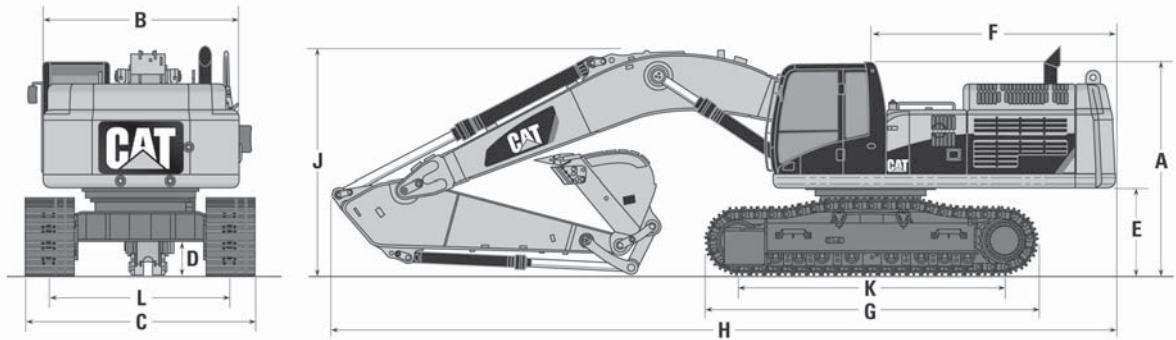

Region Offerings	390F L GP**		390F L GP***		390F L Mass****		390F L Mass*****	
	World Wide		World Wide		World Wide		World Wide	
	mm	ft	mm	ft	mm	ft	mm	ft
<b>A</b>	3830	12'7"	3830	12'7"	3830	12'7"	3830	12'7"
<b>B</b>	3470	11'5"	3470	11'5"	3470	11'5"	3470	11'5"
<b>C</b>	4260	14'0"	4260	14'0"	4260	14'0"	4260	14'0"
<b>D</b>	900	2'11"	900	2'11"	900	2'11"	900	2'11"
<b>E</b>	1640	5'5"	1640	5'5"	1640	5'5"	1640	5'5"
<b>F</b>	4700	15'5"	4700	15'5"	4700	15'5"	4700	15'5"
<b>G</b>	6360	20'10"	6360	20'10"	6360	20'10"	6360	20'10"
<b>H*</b>	14 720	48'4"	14 930	49'0"	13 550	44'6"	13 690	44'11"
<b>J*</b>	5160	16'11"	5000	16'5"	5310	17'5"	4890	16'1"
<b>K</b>	5120	16'10"	5120	16'10"	5120	16'10"	5120	16'10"
<b>L</b>	3510	11'6"	3510	11'6"	3510	11'6"	3510	11'6"

\*Varies with stick length.

\*\*GP3.4 (11'2") stick and 750 mm (30") shoe with 4.6 m<sup>3</sup> (6.0 yd<sup>3</sup>) bucket.

\*\*\*GP2.92 (9'7") stick and 750 mm (30") shoe with 4.6 m<sup>3</sup> (6.0 yd<sup>3</sup>) bucket.

\*\*\*\*M3.4 (11'2") stick and 750 mm (30") shoe with 6.0 m<sup>3</sup> (7.84 yd<sup>3</sup>) bucket.

\*\*\*\*\*M2.92 (9'7") stick and 750 mm (30") shoe with 6.0 m<sup>3</sup> (7.84 yd<sup>3</sup>) bucket.

# Hydraulic Excavators

## Major Component Weights

- 300.9D ● 301.4C ● 301.7D ● 302.2D
- 302.4D ● 302.7D CR ● 303E CR ● 303.5E CR

	<b>300.9D</b>		<b>301.4C</b>		<b>301.7D</b>		<b>302.2D</b>	
<b>Region Offerings</b>	North America, South America, Canada, Australia, New Zealand, Europe, Africa, Middle East		North America, Canada, Australia, New Zealand, Europe, Africa, Middle East		North America, South America, Canada, Australia, New Zealand, Europe, Africa, Middle East		Europe, Africa, Middle East	
<b>Buckets:</b> (see data in bucket section)	kg	lb	kg	lb	kg	lb	kg	lb
<b>Booms:**</b>								
One-piece	—		—		—		—	
<b>Sticks:**</b>								
Medium Stick	—		—		—		—	
Long Stick	—		—		—		—	
<b>Other:</b>								
Upperstructure (complete w/o ctwt)	—		—		—		—	
Standard Undercarriage (std shoe)	—		—		—		—	
Counterweight — Standard	—		—		—		—	
Extra Counterweight	—		—		—		—	

\*Boom weights include boom, boom lines, boom cylinders and rod end pins, stick cylinder, head end pin and stick lines.

\*\*Stick weights include stick, stick lines, bucket cylinder, bucket cylinder pins and bucket linkage.

	<b>302.4D</b>		<b>302.7D CR</b>		<b>303E CR</b>		<b>303.5E CR</b>	
<b>Region Offerings</b>	North America, South America, Canada, Australia, New Zealand, Europe, Africa, Middle East		North America, South America, Canada, Australia, New Zealand, Europe, Africa, Middle East		North America, South America, Canada, Australia, New Zealand		North America, South America, Canada, Australia, New Zealand, Europe, Africa, Middle East	
<b>Buckets:</b> (see data in bucket section)	kg	lb	kg	lb	kg	lb	kg	lb
<b>Booms:**</b>								
One-piece	—		—		104	229	285	630
<b>Sticks:**</b>								
Medium Stick	—		—		53	117	58	130
Long Stick	—		—		60	132	77	170
<b>Other:</b>								
Upperstructure (complete w/o ctwt)	—		—		1837	4051	1057	2330
Standard Undercarriage (std shoe)	—		—		1039	2291	1046	2310
Counterweight — Standard	—		—		—		450	1101
Extra Counterweight	—		112	247	—		—	

\*Boom weights include boom, boom lines, boom cylinders and rod end pins, stick cylinder, head end pin and stick lines.

\*\*Stick weights include stick, stick lines, bucket cylinder, bucket cylinder pins and bucket linkage.

- Major Component Weights
- 303.5E2 CR
  - 304E2 CR
  - 304.5E2 XTC
  - 305E2 CR
  - 305.5E2 CR
  - 307E2
  - 308E2 CR SB
  - 308E2 VAB

## Hydraulic Excavators

	<b>303.5E2 CR</b>		<b>304E2 CR</b>		<b>304.5E2 XTC</b>		<b>305E2 CR</b>	
<b>Region Offerings</b>	North America, South America, Canada, Australia, New Zealand, Africa, Middle East		North America, South America, Canada, Australia, New Zealand, Europe, Africa, Middle East		North America, Canada, Europe		North America, South America, Canada, Australia, New Zealand, Europe, Africa, Middle East	
<b>Buckets:</b> (see data in bucket section)	kg	lb	kg	lb	kg	lb	kg	lb
<b>Booms:*</b>								
One-piece	285	630	195	430	195	430	200	441
<b>Sticks:**</b>								
Medium Stick	58	130	95	210	95	210	90	198
Long Stick	88	194	127	280	127	280	135	298
<b>Other:</b>								
Upperstructure (complete w/o ctwt)	1057	2330	1342	2970	1342	2970	2890	6372
Standard Undercarriage (std shoe)	1046	2310	1059	2330	—	—	1650	3638
Counterweight — Standard	478	1054	505	1113	505	1113	673	1484
Extra Counterweight	—	—	—	—	—	—	—	—

\*Boom weights include boom, boom lines, boom cylinders and rod end pins, stick cylinder, head end pin and stick lines.

\*\*Stick weights include stick, stick lines, bucket cylinder, bucket cylinder pins and bucket linkage.

	<b>305.5E2 CR</b>		<b>307E2</b>		<b>308E2 CR SB</b>		<b>308E2 VAB</b>	
<b>Region Offerings</b>	North America, South America, Canada, Australia, New Zealand, Europe, Africa, Middle East		North America, Canada, Europe		North America, Canada, Australia, New Zealand, Europe		North America, Canada, Europe	
<b>Buckets:</b> (see data in bucket section)	kg	lb	kg	lb	kg	lb	kg	lb
<b>Booms:*</b>								
One-piece	215	474	545	1202	507	1115	—	—
<b>Sticks:**</b>								
Medium Stick	100	221	221	487	285	627	285	627
Long Stick	140	309	—	—	343	755	—	—
<b>Other:</b>								
Upperstructure (complete w/o ctwt)	3115	6869	2205	4861	3480	7656	3480	7656
Standard Undercarriage (std shoe)	1650	3638	2919	6435	2780	6116	2780	6116
Counterweight — Standard	896	1975	900	1984	880	1936	880	1936
Extra Counterweight	165	364	—	—	251	553	251	553

\*Boom weights include boom, boom lines, boom cylinders and rod end pins, stick cylinder, head end pin and stick lines.

\*\*Stick weights include stick, stick lines, bucket cylinder, bucket cylinder pins and bucket linkage.

# Hydraulic Excavators

## Major Component Weights

- 311F L RR ● 312D2 ● 312D2 GC ● 312D2 L
- 312E ● 312E L ● 312F GC ● 313D2

	<b>311F L RR</b>		<b>312D2</b>		<b>312D2 GC</b>		<b>312D2 L</b>	
<b>Region Offerings</b>	<b>North America, Europe, Australia, New Zealand and Polynesia, Japan</b>		<b>Asia Pacific</b>		<b>China</b>		<b>Africa, CIS, Asia Pacific, South America</b>	
<b>Buckets: (see data in bucket section)</b>	<b>kg</b>	<b>lb</b>	<b>kg</b>	<b>lb</b>	<b>kg</b>	<b>lb</b>	<b>kg</b>	<b>lb</b>
<b>Booms:*</b>								
One-piece Reach	930	<b>2050</b>	1030	<b>2270</b>	1030	<b>2270</b>	1030	<b>2270</b>
<b>Sticks:**</b>								
Medium Stick	530	<b>1170</b>	570	<b>1260</b>	570	<b>1260</b>	570	<b>1260</b>
Long Stick	610	<b>1350</b>	—	—	—	—	—	—
Extra Long Stick	—	—	650	<b>1430</b>	—	—	650	<b>1430</b>
<b>Other:</b>								
Upperstructure (complete w/o ctwt)	4050	<b>8930</b>	4490	<b>9900</b>	4490	<b>9900</b>	4490	<b>9900</b>
Standard Undercarriage (std shoe)	—	—	(500 mm/20 in) 3860	<b>8510</b>	(500 mm/20 in) 3860	<b>8510</b>	—	—
Long Undercarriage (std shoe)	(500 mm/20 in) 3890	<b>8580</b>	—	—	—	—	(500 mm/20 in) 4150	<b>9150</b>
Counterweight:								
Standard	2150	<b>4740</b>	2450	<b>5400</b>	2100	<b>4630</b>	2450	<b>5400</b>
Heavy	2450	<b>5400</b>	2650	<b>5840</b>	—	—	2650	<b>5840</b>

\*Boom weights include boom, boom lines, boom cylinders and rod end pins, stick cylinder, head end pin and stick lines.

\*\*Stick weights include stick, stick lines, bucket cylinder, bucket cylinder pins and bucket linkage.

	<b>312E</b>		<b>312E L</b>		<b>312F GC</b>		<b>313D2</b>	
<b>Region Offerings</b>	<b>Europe, Australia, New Zealand and Polynesia, Japan</b>		<b>North America, Europe, Australia, New Zealand and Polynesia</b>		<b>Japan</b>		<b>China, Asia Pacific</b>	
<b>Buckets: (see data in bucket section)</b>	<b>kg</b>	<b>lb</b>	<b>kg</b>	<b>lb</b>	<b>kg</b>	<b>lb</b>	<b>kg</b>	<b>lb</b>
<b>Booms:*</b>								
One-piece Reach	1010	<b>2230</b>	1010	<b>2230</b>	1030	<b>2270</b>	1220	<b>2690</b>
VA Boom	1740	<b>3836</b>	1740	<b>3836</b>	—	—	—	—
<b>Sticks:**</b>								
Short Stick	490	<b>1080</b>	490	<b>1080</b>	—	—	—	—
Medium Stick	480	<b>1060</b>	480	<b>1060</b>	570	<b>1260</b>	640	<b>1410</b>
Intermediate Stick	530	<b>1170</b>	—	—	—	—	—	—
Long Stick	560	<b>1230</b>	560	<b>1230</b>	650	<b>1430</b>	—	—
Extra Long Stick	—	—	—	—	—	—	—	—
<b>Other:</b>								
Upperstructure (complete w/o ctwt)	5120	<b>11,290</b>	5120	<b>11,290</b>	4420	<b>9750</b>	4490	<b>9900</b>
Standard Undercarriage (std shoe)	3840	<b>8470</b>	—	—	(500 mm/20 in) 2500	<b>5510</b>	(500 mm/20 in) 4020	<b>8860</b>
Long Undercarriage (std shoe)	—	—	4160	<b>9170</b>	—	—	—	—
Counterweight — Standard	2200	<b>4850</b>	2200	<b>4850</b>	2100	<b>4630</b>	2450	<b>5400</b>

\*Boom weights include boom, boom lines, boom cylinders and rod end pins, stick cylinder, head end pin and stick lines.

\*\*Stick weights include stick, stick lines, bucket cylinder, bucket cylinder pins, bucket linkage and stick nose pin.

Major Component Weights  
 ● 313D2 LGP ● 313F L GC ● 314E CR ● 314E LCR  
 ● 316E L ● 318D2 L ● 318E L

**Hydraulic  
Excavators**

Region Offerings	313D2 LGP		313F L GC		314E CR		314E LCR	
	Asia Pacific		North America, Europe, Turkey		Australia, New Zealand and Polynesia, Japan		North America, Europe, Australia, New Zealand and Polynesia, Japan	
Buckets: (see data in bucket section)	kg	lb	kg	lb	kg	lb	kg	lb
<b>Booms:*</b>								
One-piece Reach	1220	2690	1030	2270	1040	2290	1040	2290
Offset Boom	—	—	—	—	1730	3810	1730	3810
VA Boom	—	—	—	—	1800	3970	1800	3970
<b>Sticks:**</b>								
Medium Stick	640	1410	570	1260	570	1260	570	1260
Long Stick	—	—	650	1430	620	1370	620	1370
Extra Long Stick	650	1430	—	—	650	1430	650	1430
<b>Other:</b>								
Upperstructure (complete w/o ctwt)	4660	10,280	4420	9750	5040	11,110	5040	11,110
Standard Undercarriage (std shoe)	(960 mm/38 in)	—	—	—	(500 mm/20 in)	—	—	—
	7770	17,130	—	—	3900	8600	—	—
Long Undercarriage (std shoe)	—	—	(700 mm/28 in)	—	—	—	(500 mm/20 in)	—
	—	—	2650	5840	—	—	4230	9330
Counterweight:								
Light	—	—	—	—	2190	4830	—	—
Standard	1100	2430	—	—	—	—	3060	6750
Heavy	—	—	2450	5400	—	—	3560	7850

\*Boom weights include boom, boom lines, boom cylinders and rod end pins, stick cylinder and head end pin.

\*\*Stick weights include stick, stick lines, bucket cylinder, bucket cylinder pins, bucket linkage and stick nose pin.

Region Offerings	316E L		318D2 L		318E L	
	North America, Europe, Australia, New Zealand and Polynesia, Japan		Middle East, Africa, CIS, South America, Asia Pacific, China		North America, Europe, Australia, New Zealand and Polynesia	
Buckets: (see data in bucket section)	kg	lb	kg	lb	kg	lb
<b>Booms:*</b>						
One-piece Reach	1320	2910	1270	2800	1500	3310
HD Boom	—	—	1530	3370	—	—
VA Boom (France sourced only†)	1850	4080	—	—	1900	4190
<b>Sticks:**</b>						
Short Stick	810	1790	—	—	880	1940
Medium Stick	840	1850	780	1720	910	2010
Intermediate Stick	910	2010	—	—	—	—
HD Stick	—	—	880	1940	—	—
Long Stick	930	2050	850	1870	970	2140
Extra Long Stick	—	—	—	—	1000	2210
<b>Other:</b>						
Upperstructure (complete w/o ctwt)	5720	12,610	5330	11,750	5900	12,860
Long Undercarriage (std shoe)	5960	13,140	(600 mm/24 in)	—	6410	14,140
	—	—	6090	13,430	—	—
Counterweight — Standard	2800	6170	3170	6990	3400	7500

\*Boom weights include boom, boom lines, boom cylinders and rod end pins, stick cylinder and head end pin.

\*\*Stick weights include stick, stick lines, bucket cylinder, bucket cylinder pins, bucket linkage and stick nose pin.



# Hydraulic Excavators

## Major Component Weights

- M313D ● M315D ● M315D2 ● M316D ● M317D2
- M318D ● M320D2 ● M322D ● M322D2

	M313D†		M315D†		M315D2		M316D†		M317D2	
	kg	lb	kg	lb	kg	lb	kg	lb	kg	lb
<b>Buckets:</b> (see data in bucket section)										
<b>Booms:*</b>										
One-piece Boom	1250	<b>2756</b>	1530	<b>3374</b>	1250	<b>2756</b>	1560	<b>3440</b>	1530	<b>3374</b>
Hydraulically Adjustable Boom	1695	<b>3737</b>	2020	<b>4454</b>	1695	<b>3737</b>	2050	<b>4520</b>	2020	<b>4454</b>
<b>Sticks:**</b>										
Short Stick	370	<b>816</b>	470	<b>1036</b>	370	<b>816</b>	470	<b>1036</b>	470	<b>1036</b>
Medium Stick	390	<b>860</b>	514	<b>1133</b>	390	<b>860</b>	514	<b>1133</b>	514	<b>1133</b>
Long Stick	440	<b>970</b>	530	<b>1169</b>	440	<b>970</b>	530	<b>1169</b>	530	<b>1169</b>
<b>Other:</b>										
Upperstructure (with swing bearing, no boom)	7065	<b>15,578</b>	8126	<b>17,918</b>	7065	<b>15,578</b>	9296	<b>20,498</b>	8126	<b>17,918</b>
Undercarriage (with standard tires)	3500	<b>7718</b>	3890	<b>8577</b>	3500	<b>7718</b>	4200	<b>9261</b>	3890	<b>8577</b>
Dozer Blade (front)	750	<b>1654</b>	750	<b>1654</b>	750	<b>1654</b>	740	<b>1632</b>	750	<b>1654</b>
Dozer Blade (rear)	650	<b>1433</b>	650	<b>1433</b>	650	<b>1433</b>	770	<b>1698</b>	650	<b>1433</b>
Outriggers (front)	960	<b>2117</b>	960	<b>2117</b>	960	<b>2117</b>	1030	<b>2271</b>	960	<b>2117</b>
Outriggers (rear)	950	<b>2095</b>	950	<b>2095</b>	950	<b>2095</b>	1010	<b>2227</b>	950	<b>2095</b>

\*Boom weight includes boom, boom lines, boom cylinders, boom cylinder rod end pin, stick cylinder, stick cylinder head end pin and boom nose pin.

\*\*Stick weight includes stick, stick lines and bucket cylinder pins.

†This product has been discontinued.

	M318D†		M320D2		M322D†		M322D2	
	kg	lb	kg	lb	kg	lb	kg	lb
<b>Buckets:</b> (see data in bucket section)								
<b>Booms:*</b>								
One-piece Boom	1930	<b>4256</b>	1930	<b>4256</b>	2350	<b>5182</b>	2350	<b>5182</b>
Hydraulically Adjustable Boom	2230	<b>4917</b>	2230	<b>4917</b>	2830	<b>6240</b>	2830	<b>6240</b>
<b>Sticks:**</b>								
Short Stick	550	<b>1213</b>	550	<b>1213</b>	650	<b>1433</b>	650	<b>1433</b>
Medium Stick	580	<b>1279</b>	580	<b>1279</b>	700	<b>1544</b>	700	<b>1544</b>
Long Stick	600	<b>1323</b>	600	<b>1323</b>	780	<b>1720</b>	780	<b>1720</b>
<b>Other:</b>								
Upperstructure (with swing bearing, no boom)	10 050	<b>22,160</b>	10 050	<b>22,160</b>	10 245	<b>22,590</b>	10 245	<b>22,590</b>
Undercarriage (with standard tires)	4200	<b>9261</b>	4200	<b>9261</b>	4900	<b>10,805</b>	4900	<b>10,805</b>
Dozer Blade (front)	740	<b>1632</b>	740	<b>1632</b>	—	—	—	—
Dozer Blade (rear)	770	<b>1698</b>	770	<b>1698</b>	920	<b>2029</b>	920	<b>2029</b>
Outriggers (front)	1030	<b>2271</b>	1030	<b>2271</b>	1260	<b>2778</b>	1260	<b>2778</b>
Outriggers (rear)	1010	<b>2227</b>	1010	<b>2227</b>	1220	<b>2690</b>	1220	<b>2690</b>

\*Boom weight includes boom, boom lines, boom cylinders, boom cylinder rod end pin, stick cylinder, stick cylinder head end pin and boom nose pin.

\*\*Stick weight includes stick, stick lines and bucket cylinder pins.

†This product has been discontinued.

	<b>M314F</b>		<b>M316F</b>		<b>M318F</b>		<b>M320F</b>		<b>M322F</b>	
	<b>kg</b>	<b>lb</b>	<b>kg</b>	<b>lb</b>	<b>kg</b>	<b>lb</b>	<b>kg</b>	<b>lb</b>	<b>kg</b>	<b>lb</b>
<b>Buckets:</b> (see data in bucket section)										
<b>Booms:*</b>										
One-piece Boom	1250	<b>2756</b>	1530	<b>3374</b>	1560	<b>3440</b>	1930	<b>4256</b>	2350	<b>5182</b>
Hydraulically Adjustable Boom	1695	<b>3737</b>	2020	<b>4454</b>	2050	<b>4520</b>	2230	<b>4917</b>	2830	<b>6240</b>
<b>Sticks:**</b>										
Short Stick	370	<b>816</b>	470	<b>1036</b>	470	<b>1036</b>	550	<b>1213</b>	650	<b>1433</b>
Medium Stick	390	<b>860</b>	514	<b>1133</b>	514	<b>1133</b>	580	<b>1279</b>	700	<b>1544</b>
Long Stick	440	<b>970</b>	530	<b>1169</b>	530	<b>1169</b>	600	<b>1323</b>	780	<b>1720</b>
<b>Other:</b>										
Upperstructure (with swing bearing, no boom)	7510	<b>16,557</b>	8330	<b>18,365</b>	9565	<b>21,087</b>	10 315	<b>22,740</b>	10 045	<b>22,145</b>
Undercarriage (with standard tires)	3500	<b>7718</b>	3890	<b>8577</b>	4200	<b>9261</b>	4200	<b>9261</b>	4900	<b>10,805</b>
Dozer Blade (front)	750	<b>1654</b>	750	<b>1654</b>	740	<b>1632</b>	740	<b>1632</b>	—	
Dozer Blade (rear)	650	<b>1433</b>	650	<b>1433</b>	770	<b>1698</b>	770	<b>1698</b>	920	<b>2029</b>
Outriggers (front)	960	<b>2117</b>	960	<b>2117</b>	1030	<b>2271</b>	1030	<b>2271</b>	1260	<b>2778</b>
Outriggers (rear)	950	<b>2095</b>	950	<b>2095</b>	1010	<b>2227</b>	1010	<b>2227</b>	1220	<b>2690</b>

\*Boom weight includes boom, boom lines, boom cylinders, boom cylinder rod end pin, stick cylinder, stick cylinder head end pin and boom nose pin.

\*\*Stick weight includes stick, stick lines and bucket cylinder pins.

Region Offerings	320D2/320D2 L		320D2 GC	
	Africa, Middle East, Asia Pacific, China, Latin America		Africa, Middle East, CIS, Asia Pacific, China, Latin America	
Buckets: (see data in bucket section)	kg	lb	kg	lb
<b>Booms:*</b>				
One-piece Reach	2150	4750	2000	4410
One-piece Reach HD	2510	5540	—	—
<b>Sticks:** (for Reach Boom)</b>				
Short Stick	950	2090	—	—
Short Stick HD	1070	2360	—	—
Medium Stick	970	2140	980	2160
Medium Stick HD	1140	2510	—	—
Long Stick	1220	2690	—	—
Long Stick HD	1000	2200	—	—
<b>Booms:*</b>				
One-piece Mass	2180	4810	—	—
<b>Sticks:** (for Mass Boom)</b>				
Mass Stick	1020	2250	—	—
<b>Other:</b>				
Upperstructure (complete w/o cwtw)	6300	14,300	5930	13,080
Undercarriage				
( ) Shoe Width — Standard	(600 mm/24 in)		(600 mm/24 in)	
	6660	14,680	6250	13,780
	(700 mm/28 in)		(790 mm/31 in)	
	7000	15,430	7040	15,520
	(790 mm/31 in)		—	—
	7240	15,960	—	—
( ) Shoe Width — Long	(600 mm/24 in)		—	—
	7190	15,850	—	—
	(700 mm/28 in)		—	—
	7560	16,670	—	—
	(790 mm/31 in)		—	—
	7830	17,260	—	—
Counterweight — Standard	3700	8160	3700	8160

\*Boom weights include boom, boom lines, boom cylinders and rod end pins, stick cylinder and head end pin.

\*\*Stick weights include stick and stick lines.

Region Offerings	320E		320E LRR		320F L	
	Japan		North America		North America, Europe, Australia, New Zealand	
Buckets: (see data in bucket section)	kg	lb	kg	lb	kg	lb
<b>Booms:*</b>						
Boom HD	1720	<b>3790</b>	1720	<b>3790</b>	1740	<b>3240</b>
Boom ES	2010	<b>4430</b>	2010	<b>4430</b>	—	—
Boom HD for CGC	1730	<b>3810</b>	1730	<b>3810</b>	—	—
Boom ES for CGC	2020	<b>4450</b>	2020	<b>4450</b>	—	—
Super Long Reach	2400	<b>5290</b>	—	—	—	—
<b>Sticks:**</b>						
Medium Stick HD	680	<b>1510</b>	680	<b>1510</b>	680	<b>1500</b>
Medium Stick ES	840	<b>1850</b>	840	<b>1850</b>	—	—
Medium Stick HD for CGC	690	<b>1530</b>	690	<b>1530</b>	—	—
Medium Stick ES for CGC	850	<b>1870</b>	850	<b>1880</b>	—	—
Super Long Reach Stick	1240	<b>2740</b>	—	—	—	—
<b>Other:</b>						
Upperstructure (complete w/o ctwt)	11 300	<b>24,920</b>	6500	<b>14,330</b>	7000	<b>15,440</b>
Standard Undercarriage (std shoe)	6620	<b>14,590</b>	—	—	—	—
Long Undercarriage (std shoe)	7850	<b>17,300</b>	7850	<b>17,300</b>	7830	<b>17,270</b>
Counterweight — Standard	3550	<b>7830</b>	6200	<b>13,670</b>	3700	<b>8160</b>
— Super Long Reach	4600	<b>10,140</b>	—	—	—	—
— Heavy	5400	<b>11,910</b>	6900	<b>15,210</b>	—	—

\*Boom weights include boom, boom lines, boom cylinders and rod end pins, stick cylinder and head end pin.

\*\*Stick weights include stick and stick lines.

**323D2 L**

<b>Region Offerings</b>	<b>Africa, Middle East, China, Latin America</b>	
<b>Buckets: (see data in bucket section)</b>	<b>kg</b>	<b>lb</b>
<b>Booms:*</b>		
One-piece Reach HD	2410	<b>5310</b>
<b>Sticks:** (for Reach Boom)</b>		
Short Stick HD	1130	<b>2490</b>
Long Stick HD	1100	<b>2430</b>
<b>Booms:*</b>		
One-piece Mass	2080	<b>4590</b>
<b>Sticks:** (for Mass Boom)</b>		
Short Stick	1170	<b>2580</b>
<b>Other:</b>		
Upperstructure (complete w/o ctwt)	6480	<b>14,290</b>
Undercarriage		
( ) Shoe Width — Long		
	7190	(600 mm/24 in) <b>15,850</b>
	7570	(700 mm/28 in) <b>16,690</b>
	7840	(790 mm/31 in) <b>17,280</b>
Counterweight — Standard	4260	<b>9390</b>

\*Boom weights include boom, boom lines, boom cylinders and rod end pins, stick cylinder and head end pin.  
\*\*Stick weights include stick and stick lines.

Region Offerings	323F L		323F LN	
	North America, Europe, Australia, New Zealand		Europe	
Buckets: (see data in bucket section)	kg	lb	kg	lb
<b>Booms:*</b>				
One Piece Reach	1680	<b>3704</b>	1740	<b>3840</b>
One Piece Reach HD	1726	<b>3805</b>	—	
One Piece Reach ES	2016	<b>4445</b>	—	
Super Long Reach	2397	<b>5284</b>	—	
<b>Sticks:**</b>				
Medium Stick	—		970	<b>2140</b>
Medium Stick (CGC)	970	<b>2138</b>	—	
Medium Stick ES (CGC)	1143	<b>2520</b>	—	
Medium Stick Thumb Ready ES (CGC)	1265	<b>2789</b>	—	
Intermediate Stick	—		970	<b>2140</b>
Long Stick	1228	<b>2707</b>	—	
Super Long Reach	1328	<b>2928</b>	—	
<b>Other:</b>				
Upperstructure (complete w/o ctwt)	11 220	<b>24,736</b>	7230	<b>15,940</b>
Undercarriage (std shoe)				
Long	7850	<b>17,306</b>	—	
( ) Shoe Width — Long Narrow		—	(500 mm/20 in)	
		—	6880	<b>15,170</b>
Counterweight — Standard	4100	<b>9040</b>	4550	<b>10,030</b>
— Heavy	5350	<b>11,790</b>	—	
— Super Long Reach	4700	<b>10,360</b>	—	

\*Boom weights include boom, boom lines, boom cylinders and rod end pins, stick cylinder and head end pin.

\*\*Stick weights include stick and stick lines.

Region Offerings	325F L		326D2 L	
	North America, Europe, Australia, New Zealand, Japan, Hong Kong, Taiwan		South America, Middle East, Africa, CIS, Asia Pacific, China	
Buckets: (see data in bucket section)	kg	lb	kg	lb
<b>Booms:*</b>				
One-piece Reach	1740	<b>3840</b>	2040	<b>4500</b>
VA Boom	2783	<b>6140</b>	—	
<b>Sticks:** (for Reach Boom)</b>				
Short Stick		—	1170	<b>2580</b>
Medium Stick	975	<b>2150</b>	1220	<b>2690</b>
<b>Booms:*</b>				
One-piece Mass		—	2150	<b>4740</b>
<b>Sticks:** (for Mass Boom)</b>				
Short Stick		—	1500	<b>3310</b>
<b>Other:</b>				
Upperstructure (complete w/o ctwt)	7028	<b>15,500</b>	7220	<b>15,920</b>
Undercarriage				
( ) Shoe Width — Long		(790 mm/31 in)		(600 mm/24 in)
	7878	<b>17,370</b>	8660	<b>19,090</b>
		—		(DG 600 mm/24 in)
		—	8970	<b>19,770</b>
		—		(790 mm/31 in)
		—	9240	<b>20,370</b>
Counterweight — Standard	6800	<b>14,990</b>	4750	<b>10,470</b>
— L		—	6780	<b>14,950</b>

\*Boom weights include boom, boom lines, boom cylinders and rod end pins, stick cylinder and head end pin.

\*\*Stick weights include stick and stick lines.

Region Offerings	326F L		326F LN	
	Japan, North America, Europe, Australia, New Zealand		Europe	
Buckets: (see data in bucket section)	kg	lb	kg	lb
<b>Booms:*</b>				
One-piece Reach	1740	3836	1740	3836
<b>Sticks:** (for Reach Boom)</b>				
Short Stick	780	1720	780	1720
Medium Stick	840	1852	840	1852
<b>Booms:*</b>				
One-piece Mass	1850	4079	1850	4079
<b>Sticks:** (for Mass Boom)</b>				
Short Stick	970	2139	970	2139
<b>Other:</b>				
Upperstructure (complete w/o ctwt)	8930	19,690	8930	19,690
Undercarriage				
( ) Shoe Width — Long		(600 mm/24 in)	—	
	8535	18,816	—	
		(790 mm/31 in)	—	
	9239	20,369	—	
( ) Shoe Width — Long Narrow		—	(600 mm/24 in)	
		—	8441	18,609
		—	(790 mm/31 in)	
		—	9145	20,161
Counterweight — Standard	4000	8819	4000	8819
— Heavy	6750	14,881	6750	14,881

7

\*Boom weights include boom, boom lines, boom cylinders and rod end pins, stick cylinder and head end pin.  
 \*\*Stick weights include stick and stick lines.



Region Offerings	330D2 L		330F L	
	South America, Middle East, Africa, CIS, Asia Pacific, China		Japan, North America, Europe, Australia, New Zealand, South Korea	
Buckets: (see data in bucket section)	kg	lb	kg	lb
<b>Booms:*</b>				
One-piece Reach	2270	<b>5000</b>	—	
One-piece Reach HD	—		1950	<b>4300</b>
<b>Sticks:** (for Reach Boom)</b>				
Short Stick	1270	<b>2800</b>	830	<b>1830</b>
Medium Stick	1440	<b>3170</b>	980	<b>2160</b>
Long Stick	—		1160	<b>2558</b>
<b>Booms:*</b>				
One-piece Mass	2390	<b>5270</b>	2020	<b>4450</b>
<b>Sticks:** (for Mass Boom)</b>				
Short Stick	1550	<b>3420</b>	1020	<b>2250</b>
<b>Other:</b>				
Upperstructure (complete w/o ctwt)	7290	<b>16,070</b>	9150	<b>20,160</b>
Undercarriage				
( ) Shoe Width — Long				
(600 mm/24 in)			(600 mm/24 in)	
10 210		<b>22,510</b>	9580	<b>21,120</b>
(HD 600 mm/24 in)			(700 mm/28 in)	
10 750		<b>23,700</b>	9910	<b>21,850</b>
(DG 600 mm/24 in)			(800 mm/32 in)	
10 630		<b>23,440</b>	10 540	<b>23,240</b>
(700 mm/28 in)			—	
10 540		<b>23,240</b>	—	
(800 mm/32 in)			—	
11 170		<b>24,630</b>	—	
Counterweight — Standard	5860	<b>12,920</b>	5400	<b>11,900</b>
— Heavy	6750	<b>14,880</b>	5800	<b>12,878</b>
— SLR	—		6750	<b>14,880</b>

\*Boom weights include boom, boom lines, boom cylinders and rod end pins, stick cylinder and head end pin.

\*\*Stick weights include stick and stick lines.

Region Offerings	330F LN		335F L		336D/ 336D L	
	Europe		North America, Europe, Australia, New Zealand, Hong Kong, Taiwan		Asia Pacific, South America	
Buckets: (see data in bucket section)	kg	lb	kg	lb	kg	lb
<b>Booms:*</b>						
One-piece Reach HD	1950	4300	1950	4299	3495	7706
<b>Sticks:** (for Reach Boom)</b>						
Short Stick	830	1830	700	1543	1890	4170
•	—	—	—	—	2012	4436
Medium Stick	980	2160	980	2161	—	—
Long Stick	1160	2558	1160	2557	—	—
<b>Booms:*</b>						
One-piece Mass	2020	4450	—	—	3283	7238
<b>Sticks:** (for Mass Boom)</b>						
Short Stick	1020	2250	970	2138	—	—
<b>Sticks:** (for Mass Boom &amp; VA Boom)</b>						
Short Stick	—	—	—	—	2079	4583
<b>Other:</b>						
Upperstructure (complete w/o cwt)	9150	20,160	9669	21,317	8160	17,990
Undercarriage						
( ) Shoe Width — Standard	—	—	—	—	(600 mm/24 in)	—
	—	—	—	—	11 980	26,411
	—	—	—	—	(700 mm/28 in)	—
	—	—	—	—	12 278	27,068
	—	—	—	—	(800 mm/32 in)	—
	—	—	—	—	12 906	28,453
( ) Shoe Width — Long	—	—	(600 mm/24 in)	—	(600 mm/24 in)	—
	—	—	4066	8964	12 884	28,404
	—	—	(700 mm/28 in)	—	(700 mm/28 in)	—
	—	—	4391	9681	13 210	29,123
	—	—	(800 mm/32 in)	—	(800 mm/32 in)	—
	—	—	5365	11,828	13 894	30,631
( ) Shoe Width — Long Narrow	(600 mm/24 in)	—	—	—	—	—
	9570	21,090	—	—	—	—
	(700 mm/28 in)	—	—	—	—	—
	9900	21,830	—	—	—	—
	(800 mm/32 in)	—	—	—	—	—
	10 530	23,210	—	—	—	—
Counterweight — Standard	—	—	7700	16,976	6020	13,272
— Heavy	5800	12,878	—	—	—	—

\*Boom weights include boom, boom lines, boom cylinders and rod end pins, stick cylinder and head end pin.

\*\*Stick weights include stick and stick lines.

	<b>336D L/ 336D LN</b>		<b>336D2 GC</b>		<b>336D2 XE 336D2 L XE</b>	
<b>Region Offerings</b>	<b>Middle East, Africa</b>		—		—	
<b>Buckets: (see data in bucket section)</b>	<b>kg</b>	<b>lb</b>	<b>kg</b>	<b>lb</b>	<b>kg</b>	<b>lb</b>
<b>Booms:*</b>						
One-piece Reach	—	—	3900	<b>8600</b>	—	—
One-piece Reach HD	3255	<b>7176</b>	—	—	4200	<b>9300</b>
<b>Sticks:** (for Reach Boom)</b>						
Short Stick	1867	<b>4116</b>	1700	<b>3700</b>	—	—
Short Stick HD	—	—	—	—	1900	<b>4200</b>
Medium Stick	2012	<b>4436</b>	—	—	1800	<b>4000</b>
Medium Stick HD	—	—	—	—	2000	<b>4400</b>
Long Stick	2180	<b>4807</b>	—	—	2100	<b>4600</b>
Long Stick HD	2305	<b>5083</b>	—	—	—	—
<b>Booms:*</b>						
One-piece Mass	3283	<b>7238</b>	—	—	4000	<b>8800</b>
VA Boom	4433	<b>9775</b>	—	—	—	—
<b>Sticks:** (for Mass Boom)</b>						
Short Stick	2079	<b>4583</b>	—	—	1900	<b>4200</b>
Medium Stick	—	—	—	—	2000	<b>4400</b>
<b>Other:</b>						
Upperstructure (complete w/o ctwt)	8160	<b>17,990</b>	8200	<b>18,100</b>	9700	<b>21,400</b>
Undercarriage						
( ) Shoe Width — Standard	—	—	(TG 600 mm/24 in)	—	(600 mm/24 in)	—
	—	—	11 760	<b>25,800</b>	11 900	<b>26,300</b>
( ) Shoe Width — Long	—	—	—	—	(TG 600 mm/24 in)	—
	—	—	—	—	12 400	<b>27,400</b>
	—	—	—	—	(TG 700 mm/28 in)	—
	—	—	—	—	12 700	<b>28,000</b>
Undercarriage — L	12 278	<b>27,068</b>	—	—	—	—
— LN	11 980	<b>26,411</b>	—	—	—	—
— ES	15 020	<b>33,119</b>	—	—	—	—
Counterweight — Standard	—	—	5200	<b>11,500</b>	5200	<b>11,500</b>
— L	6260	<b>13,803</b>	—	—	—	—
— LN	6260	<b>13,803</b>	—	—	—	—
— Heavy	—	—	—	—	5400	<b>11,900</b>

\*Boom weights include boom, boom lines, boom cylinders and rod end pins, stick cylinder and head end pin.

\*\*Stick weights include stick and stick lines.

Region Offerings	336E/ 336E L/ 336E LN		336E L H/ 336E LN H		336F L	
	North America, Japan, Europe		North America, Japan, Europe		North America, Japan, Europe	
Buckets: (see data in bucket section)	kg	lb	kg	lb	kg	lb
<b>Booms:**</b>						
One-piece Reach HD	3915	<b>8631</b>	3915	<b>8631</b>	3915	<b>8631</b>
<b>Sticks:** (for Reach Boom)</b>						
Medium Stick	1881	<b>4147</b>	1881	<b>4147</b>	1881	<b>4147</b>
Long HD Stick	2045	<b>4508</b>	2045	<b>4508</b>	2045	<b>4508</b>
Long ES Stick	2336	<b>5150</b>		—	2336	<b>5150</b>
<b>Sticks:** (for Mass Boom)</b>						
Medium Stick	2216	<b>4885</b>		—	2216	<b>4885</b>
<b>Other:</b>						
Upperstructure (complete w/o ctwt)	9677	<b>21,312</b>	10 000	<b>22,000</b>	9677	<b>21,312</b>
Undercarriage						
( ) Shoe Width — Long						
	(600 mm/24 in)		(600 mm/24 in)		(600 mm/24 in)	
	8160	<b>17,990</b>	8160	<b>17,990</b>	8160	<b>17,990</b>
	(700 mm/28 in)		(700 mm/28 in)		(700 mm/28 in)	
	8812	<b>10,428</b>	8812	<b>10,428</b>	8812	<b>10,428</b>
	(800 mm/32 in)		(800 mm/32 in)		(800 mm/32 in)	
	10 180	<b>22,444</b>	10 180	<b>22,444</b>	10 180	<b>22,444</b>
Counterweight — Standard	6000	<b>13,228</b>	4900	<b>10,800</b>	6000	<b>13,200</b>

\*Boom weights include boom, boom lines, boom cylinders and rod end pins, stick cylinder and head end pin.

\*\*Stick weights include stick and stick lines.

# Hydraulic Excavators

## Major Component Weights

- 336F ● 336F L ● 336F LN ● 336F L XE
- 336F LN XE ● 340D2 L ● 340F L

Region Offerings	336F/ 336F L 336F LN		336F L XE 336F LN XE		340D2 L		340F L	
	North America, Europe		North America, Europe		China, S.E. Asia, South America except Brazil, Africa, Middle East, CIS		Europe	
Buckets: (see data in bucket section)	kg	lb	kg	lb	kg	lb	kg	lb
<b>Booms:*</b>								
One-piece Reach	—		—		—		4400	9700
One-piece Reach HD	4100	9000	4100	9000	4200	9300	—	
One-piece Reach ES	4300	9500	4300	9500	—		—	
<b>Sticks:** (for Reach Boom)</b>								
Short Stick	—		—		1900	4200	1800	4000
Short Stick HD	1800	4000	1800	4000	2000	4400	1900	4200
Medium Stick HD	1800	4000	1800	4000	—		—	
Medium Stick ES	1900	4200	1900	4200	—		—	
Long Stick HD	1900	4200	1900	4200	—		—	
Long Stick ES	2100	4600	2100	4600	—		—	
<b>Booms:*</b>								
One-piece Mass	4200	9300	4200	9300	4000	8800	4400	9700
<b>Sticks:** (for Mass Boom)</b>								
Short Stick	—		—		1900	4200	—	
Medium Stick	2100	4600	2100	4600	2000	4400	2100	4600
<b>Other:</b>								
Upperstructure (complete w/o cwtwt)	9900 10 000	21,800 22,000	10 700 11 200	23,600 24,700	8200	18,100	10 000	22,000
Undercarriage								
( ) Shoe Width — Standard	(TG 700 mm/28 in)		—		—		—	
	12 100	26,700	—		—		—	
( ) Shoe Width — Long	(TG 600 mm/24 in)		(TG 600 mm/24 in)		(DG 600 mm/24 in)		(DG 600 mm/24 in)	
	13 600	30,000	13 600	30,000	16 200	35,700	15 700	34,600
	(TG 850 mm/33 in)		(TG 850 mm/33 in)		—		(TG 600 mm/24 in)	
	14 300	31,500	14 300	31,500	—		14 900	32,800
( ) Shoe Width — Long Narrow	(TG 600 mm/24 in)		(TG 600 mm/24 in)		—		—	
	13 500	29,800	13 500	29,800	—		—	
Counterweight — Standard	6000	13,200	5100	11,200	6300	13,900	7000	15,400
— Heavy	7000	15,400	6100	13,400	8500	18,700	—	

\*Boom weights include boom, boom lines, boom cylinders and rod end pins, stick cylinder and head end pin.

\*\*Stick weights include stick and stick lines.

Region Offerings	349D2/ 349D2 L		349D2 L		349F L	
	Africa, Middle East, Asia Pasific, CIS, South America except Brazil		Turkey, Hong Kong, Brazil		North America, Japan, New Zealand, Australia, South Korea	
Buckets: (see data in bucket section)	kg	lb	kg	lb	kg	lb
<b>Booms:*</b>						
One-piece Reach	5135	<b>11,323</b>	5135	<b>11,323</b>	4630	<b>10,200</b>
One-piece Long Reach	—		—		5190	<b>11,400</b>
<b>Sticks:** (for Reach Boom)</b>						
Short Stick	1670	<b>3680</b>	1670	<b>3680</b>	—	
Medium Stick	1690	<b>3730</b>	1690	<b>3730</b>	2540	<b>5600</b>
Long Stick	1850	<b>3980</b>	1850	<b>3980</b>	2750	<b>6060</b>
Long Reach Stick	—		—		2990	<b>6600</b>
<b>Booms:*</b>						
One-piece Mass	5474	<b>12,068</b>	5474	<b>12,068</b>	4860	<b>10,700</b>
<b>Sticks:** (for Mass Boom)</b>						
Short Stick	1765	<b>3890</b>	1765	<b>3890</b>	2930	<b>6460</b>
Long Stick	1945	<b>4290</b>	1945	<b>4290</b>	3140	<b>6900</b>
<b>Other:</b>						
Upperstructure (complete w/o ctwt)						
Standard	10 800	<b>23,810</b>	—		—	
Long (FIX)	10 800	<b>23,810</b>	10 800	<b>23,810</b>	24 800	<b>54,700</b>
Undercarriage						
( ) Shoe Width — Standard		(750 mm/30 in)	—		—	
	15 950	<b>35,160</b>	—		—	
( ) Shoe Width — Long (FIX)		(750 mm/30 in)		(750 mm/30 in)		(900 mm/35 in)
	16 560	<b>36,510</b>	16 560	<b>36,510</b>	6640	<b>14,600</b>
Counterweight — Standard	9000	<b>19,800</b>	9000	<b>19,800</b>	9000	<b>19,800</b>

\*Boom weights include: boom, boom lines, cylinders, rod end pins, stick cylinder and head end pin.

\*\*Stick weights include stick, stick lines, bucket linkage and bucket cylinder.

NOTE: Heavy duty track shoes available.

Region Offerings	349F L XE		352F		352F XE	
	North America, New Zealand, Australia		Europe, North America, Japan		Europe	
Buckets: (see data in bucket section)	kg	lb	kg	lb	kg	lb
<b>Booms:*</b>						
One-piece Reach HD	4630	<b>10,200</b>	4630	<b>10,200</b>	4630	<b>10,200</b>
<b>Sticks:** (for Reach Boom)</b>						
Short Stick HD	2400	<b>5300</b>	2400	<b>5300</b>	2400	<b>5300</b>
Medium Stick HD	2540	<b>5600</b>	2540	<b>5600</b>	2540	<b>5600</b>
Long Stick HD	2760	<b>6100</b>	2760	<b>6100</b>	2760	<b>6100</b>
<b>Booms:*</b>						
One-piece Mass	4860	<b>10,700</b>	4860	<b>10,700</b>	4860	<b>10,700</b>
<b>Sticks:** (for Mass Boom)</b>						
Short Stick	3140	<b>6900</b>	3140	<b>6900</b>	3140	<b>6900</b>
Medium Stick	2930	<b>6500</b>	2930	<b>6500</b>	2930	<b>6500</b>
<b>Other:</b>						
Upperstructure (complete w/o cwt)	24 800	<b>54,700</b>	27 000	<b>59,500</b>	27 000	<b>59,500</b>
Undercarriage						
( ) Shoe Width — Long (FIX)	(TG 900 mm/35 in)		—		—	
	16 900	<b>37,300</b>	—		—	
	—		(DG 600 mm/24 in)		(DG 600 mm/24 in)	
	—		18 000	<b>39,700</b>	18 000	<b>39,700</b>
( ) Shoe Width — Long (VG)	—		(TG 900 mm/35 in)		(TG 750 mm/30 in)	
	—		19 400	<b>42,800</b>	19 400	<b>42,800</b>
Counterweight — Standard	8600	<b>19,000</b>	8600	<b>19,000</b>	8600	<b>19,000</b>
— Heavy	9000	<b>19,800</b>	9000	<b>19,800</b>	9000	<b>19,800</b>

\*Boom weights include: boom, boom lines, cylinders, rod end pins, stick cylinder and head end pin.

\*\*Stick weights include stick, stick lines, bucket linkage and bucket cylinder.

**NOTE:** Heavy duty track shoes available.

Region Offerings	374F L		390F L	
	World Wide		World Wide	
Buckets: (see data in bucket section)	kg	lb	kg	lb
<b>Booms:*</b>				
One-piece Reach	6717	<b>14,808</b>	9839	<b>21,691</b>
<b>Sticks:** (for Reach Boom)</b>				
Short Stick	3487	<b>7688</b>	4922	<b>10,851</b>
•	3674	<b>8100</b>	—	
•	3816	<b>8413</b>	—	
Long Stick	4025	<b>8874</b>	5430	<b>11,971</b>
<b>Booms:*</b>				
One-piece General Purpose	—		8392	<b>18,501</b>
<b>Sticks:** (for General Purpose Boom)</b>				
Short Stick	—		4883	<b>10,765</b>
Medium Stick	—		5186	<b>11,433</b>
Long Stick	—		4680	<b>10,318</b>
<b>Booms:*</b>				
One-piece Mass	7037	<b>15,514</b>	8437	<b>18,600</b>
<b>Sticks:** (for Mass Boom)</b>				
Short Stick	4019	<b>8860</b>	5189	<b>11,440</b>
Long Stick	4228	<b>9321</b>	5447	<b>12,009</b>
<b>Other:</b>				
Upperstructure (complete w/o ctwt)	17 905	<b>39,474</b>	21 336	<b>47,038</b>
Undercarriage				
( ) Shoe Width — Long	(900 mm/35 in)		(900 mm/35 in)	
	28 218	<b>62,210</b>	34 924	<b>76,994</b>
	(750 mm/30 in)		(750 mm/30 in)	
	27 205	<b>59,977</b>	33 877	<b>74,686</b>
	(650 mm/26 in)		(650 mm/26 in)	
	26 530	<b>58,489</b>	33 003	<b>72,759</b>
Counterweight — Standard	11 000	<b>24,251</b>	12 400	<b>27,337</b>
— Removal	10 300	<b>22,708</b>	12 400	<b>27,337</b>

\*Boom weights include: boom, boom lines, cylinders, rod end pins, stick cylinder and head end pin.

\*\*Stick weights include stick and stick lines.

NOTE: Heavy duty track shoes available.



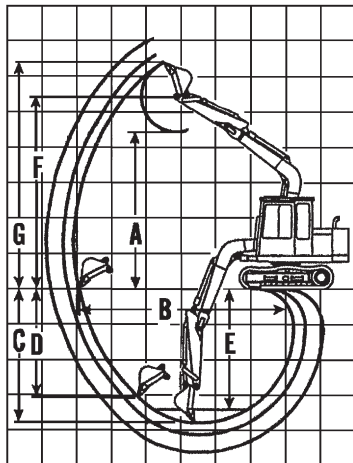

**One-Piece Boom  
Digging Envelope**

- Standard shoes and undercarriage
- Lug height not included

**KEY:**

- 
- A** Maximum loading height of bucket with teeth
  - B** Maximum reach at ground level
  - C** Maximum digging depth
  - D** Maximum vertical wall
  - E** Maximum depth of cut for 2.44 m (8'0") level bottom (straight clean up)
  - F** Maximum bucket hinge pin height
  - G** Maximum height, to bucket teeth at highest arc
- 

Stick	300.9D		1.10 m		301.4C		3'6"		1100 mm		3'7"		980 mm		3'3"		1180 mm		3'10"		
	mm	ft	mm	ft	mm	ft	mm	ft	mm	ft	mm	ft	mm	ft	mm	ft	mm	ft	mm	ft	
<b>A</b>	2035	6'8"	2403	7'9"	2517	8'3"	2502	8'3"	2613	8'7"											
<b>B</b>	3023	9'11"	3650	11'9"	3791	12'4"	3700	12'2"	3894	12'9"											
<b>C</b>	1731	5'8"	2210	7'2"	2370	7'7"	2201	7'3"	2401	7'11"											
<b>D</b>	1349	4'5"	1482	4'8"	1626	5'3"	1431	4'8"	1616	5'4"											
<b>E</b>	—	—	—	—	—	—	—	—	—	—											
<b>F</b>	—	—	—	—	—	—	—	—	—	—											
<b>G</b>	2863	9'5"	3390	11'1"	3507	11'5"	3484	11'5"	3594	11'9"											

Stick	301.7D CR		1100 mm		3'7"		1050 mm		3'5"		1250 mm		4'1"	
	mm	ft	mm	ft	mm	ft	mm	ft	mm	ft	mm	ft	mm	ft
<b>A</b>	2441	8'0"	2555	8'5"	2720	8'11"	2810	9'2"						
<b>B</b>	3842	12'7"	3995	13'1"	4130	13'6"	4330	14'2"						
<b>C</b>	2321	7'7"	2481	8'2"	2490	8'2"	2690	8'10"						
<b>D</b>	1578	5'2"	1718	5'7"	1670	5'6"	1850	6'0"						
<b>E</b>	—	—	—	—	—	—	—	—						
<b>F</b>	—	—	—	—	—	—	—	—						
<b>G</b>	3434	11'3"	3548	11'8"	3840	12'6"	3930	12'10"						

- 302.4D
- 302.7D CR
- 303E CR
- 303.5E CR
- 303.5E2 CR

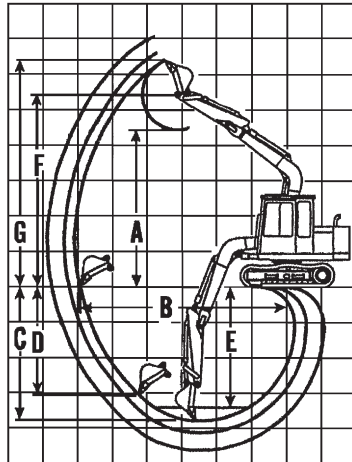

**One-Piece Boom  
Digging Envelope**

- Standard shoes and undercarriage
- Lug height not included

**KEY:**

- A** Maximum loading height of bucket with teeth
- B** Maximum reach at ground level
- C** Maximum digging depth
- D** Maximum vertical wall
- E** Maximum depth of cut for 2.44 m (8'0") level bottom (straight clean up)
- F** Maximum bucket hinge pin height
- G** Maximum height, to bucket teeth at highest arc

Stick	302.4D				302.7D CR				303E CR			
	1050 mm	3'5"	1250 mm	4'1"	1.05 m	3'5"	1.25 m	4'2"	1.26 m	4'2"		
	mm	ft	mm	ft	mm	ft	mm	ft	mm	ft		
<b>A</b>	2747	9'0"	2870	9'5"	2840	9'3"	2970	9'7"	3150	10'4"		
<b>B</b>	4021	13'2"	4216	13'10"	4481	14'7"	4681	15'4"	4810	15'9"		
<b>C</b>	2402	7'11"	2602	8'6"	2544	8'3"	2744	9'0"	2750	9'0"		
<b>D</b>	1567	5'2"	1752	5'9"	1962	6'4"	2152	7'1"	1960	6'5"		
<b>E</b>	—	—	—	—	—	—	—	—	2220	7'3"		
<b>F</b>	—	—	—	—	—	—	—	—	3870	12'8"		
<b>G</b>	3949	12'11"	4071	13'4"	4170	13'7"	4300	14'1"	4530	14'10"		

Stick	303.5E CR				303.5E2 CR			
	1.26 m	4'2"	1.56 m	5'1"	1.26 m	4'2"	1.56 m	5'1"
	mm	ft	mm	ft	mm	ft	mm	ft
<b>A</b>	3520	11'6"	3640	11'11"	3520	11'6"	3640	11'11"
<b>B</b>	5060	16'8"	5320	17'6"	5060	16'8"	5320	17'6"
<b>C</b>	2880	9'6"	3180	10'4"	2880	9'6"	3180	10'4"
<b>D</b>	2320	7'8"	2470	8'2"	2320	7'8"	2470	8'1"
<b>E</b>	2380	7'10"	2720	8'11"	2380	7'10"	2720	8'11"
<b>F</b>	4230	13'11"	4350	14'3"	4230	13'11"	4350	14'3"
<b>G</b>	4920	16'2"	5030	16'6"	4920	16'2"	5030	16'6"

## Range Dimensions

- 304E2 CR ● 304.5 E2 XTC ● 305E2 CR
- 305.5E2 CR ● 307E2 ● 308E2 CR SB ● 308E2 VAB

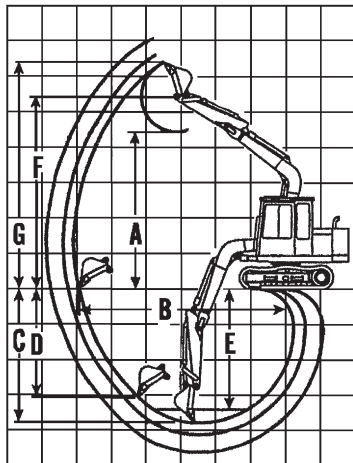

### One-Piece Boom Digging Envelope

- Standard shoes and undercarriage
- Lug height not included

#### KEY:

- A** Maximum loading height of bucket with teeth
- B** Maximum reach at ground level
- C** Maximum digging depth
- D** Maximum vertical wall
- E** Maximum depth of cut for 2.44 m (8'0") level bottom (straight clean up)
- F** Maximum bucket hinge pin height
- G** Maximum height, to bucket teeth at highest arc

Stick	304E2 CR				304.5 E2 XTC				305E2 CR			
	1.32 m	4'4"	1.62 m	5'4"	1.32 m	4'4"	1.62 m	5'4"	1.35 m	4'4"	1.75 m	5'7"
	mm	ft	mm	ft	mm	ft	mm	ft	mm	ft	mm	ft
<b>A</b>	3590	11'9"	3690	12'1"	3590	11'9"	3690	12'1"	3720	12'2"	3920	12'10"
<b>B</b>	5220	17'2"	5470	18'0"	5220	17'2"	5470	18'0"	5330	17'6"	5810	19'1"
<b>C</b>	3130	10'3"	3430	11'3"	3130	10'3"	3430	11'3"	3280	10'9"	3670	12'0"
<b>D</b>	2420	7'11"	2560	8'5"	2420	7'11"	2560	8'5"	2320	7'7"	2630	8'8"
<b>E</b>	2650	8'8"	2980	9'9"	2650	8'8"	2980	9'9"	2850	9'4"	3290	10'9"
<b>F</b>	4300	14'1"	4400	14'5"	4300	14'1"	4400	14'5"	4500	14'9"	4710	15'4"
<b>G</b>	4980	16'4"	5070	16'8"	4980	16'4"	5070	16'8"	5250	17'3"	5440	17'10"

Stick	305.5E2 CR				307E2		308E2 CR SB		308E2 VAB			
	1.42 m	4'7"	1.82 m	5'10"	1.67 m	5'6"	1.67 m	5'6"	2.21 m	7'3"	1.67 m	5'6"
	mm	ft	mm	ft	mm	ft	m	ft	m	ft	mm	in
<b>A</b>	3820	12'6"	4080	13'5"	5190	17'0"	4.67	15'4"	5.01	16'5"	6080	239
<b>B</b>	5630	18'6"	6020	19'9"	6160	20'3"	6.82	22'9"	7.35	24'1"	7632	300
<b>C</b>	3470	11'5"	3870	12'8"	4070	13'4"	4.15	13'7"	4.69	15'5"	4290	169
<b>D</b>	2330	7'8"	2730	8'11"	3630	11'11"	2.98	9'9"	3.55	11'8"	3820	150
<b>E</b>	3040	9'11"	3490	11'5"	3740	12'3"	3.76	12'4"	4.34	14'3"	—	—
<b>F</b>	4610	15'1"	4860	15'11"	6220	20'5"	5.69	18'8"	6.03	19'9"	—	—
<b>G</b>	5330	17'6"	5590	18'4"	7240	23'9"	6.64	21'9"	6.99	22'11"	8000	315

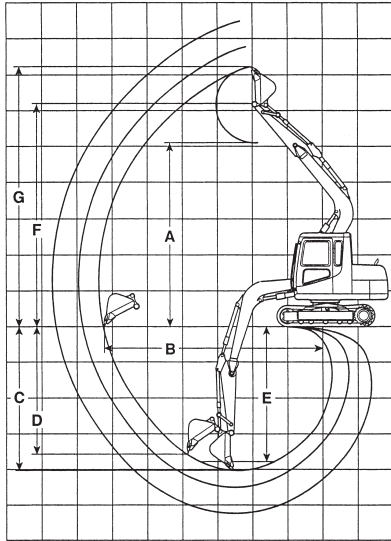

**One-Piece and VA Booms Digging Envelope**

- Standard shoes and undercarriage
- Lug height not included

**KEY:**

- A** Maximum loading height of bucket with teeth
- B** Maximum reach at ground level
- C** Maximum digging depth
- D** Maximum vertical wall
- E** Maximum depth of cut for 2.44 m (8'0") level bottom (straight clean up)
- F** Maximum bucket hinge pin height
- G** Maximum height, to bucket teeth at highest arc

**311F L RR Reach Boom**

**312D2, 312D2 L**

Stick	2.25 m		2.8 m		2.5 m		3.0 m	
	m	ft	m	ft	m	ft	m	ft
<b>A</b>	5.44	17'1"	5.77	18'11"	6.10	20'0"	6.33	20'9"
<b>B</b>	7.57	24'10"	8.1	26'7"	8.18	26'10"	8.63	28'4"
<b>C</b>	5.04	16'6"	5.59	18'4"	5.54	18'2"	6.04	19'10"
<b>D</b>	4.36	14'4"	4.88	16'0"	4.64	15'3"	4.99	16'4"
<b>E</b>	4.33	14'2"	4.99	16'4"	5.33	17'6"	5.86	19'3"
<b>F</b>	—	—	—	—	—	—	—	—
<b>G</b>	7.82	25'8"	8.14	26'8"	8.49	27'10"	8.71	28'7"

**312E Reach Boom**

**312E VA**

Stick	2.1 m		2.5 m		2.8 m		3.0 m		2.1 m		2.5 m	
	mm	ft	mm	ft	mm	ft	mm	ft	mm	ft	mm	ft
<b>A</b>	5850	19'2"	6100	20'0"	6210	20'4"	6330	20'9"	6810	22'4"	7160	23'6"
<b>B</b>	7790	25'7"	8170	26'10"	8430	27'8"	8620	28'3"	7920	26'0"	8310	27'3"
<b>C</b>	5140	16'10"	5540	18'2"	5840	19'2"	6040	19'10"	4820	15'10"	5210	17'1"
<b>D</b>	4380	14'5"	4840	15'11"	5070	16'8"	5200	17'1"	3840	12'7"	4260	14'0"
<b>E</b>	4900	16'1"	5330	17'6"	5650	18'6"	5860	19'3"	4860	15'11"	5090	16'8"
<b>F</b>	—	—	—	—	—	—	—	—	—	—	—	—
<b>G</b>	8230	27'0"	8490	27'10"	8590	28'2"	8710	28'7"	9250	30'4"	9610	31'6"

# Hydraulic Excavators

## Range Dimensions

- 312D2 GC ● 312F GC ● 313D2 ● 313D2 LGP
- 313F L GC ● 314E CR ● 314E LCR

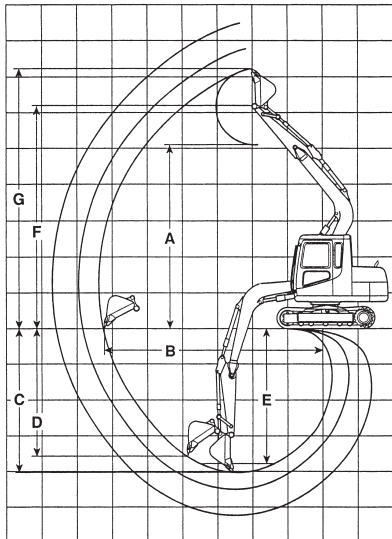

## One-Piece and VA Booms Digging Envelope

- Standard shoes and undercarriage
- Lug height not included

### KEY:

- A** Maximum loading height of bucket with teeth
- B** Maximum reach at ground level
- C** Maximum digging depth
- D** Maximum vertical wall
- E** Maximum depth of cut for 2.44 m (8'0\") level bottom (straight clean up)
- F** Maximum bucket hinge pin height
- G** Maximum height, to bucket teeth at highest arc

Stick	312D2 GC		312F GC		313D2		313D2 LGP		313F L GC*		313F L GC*			
	2.5 m	8'2"	2.5 m	8'2"	2.5 m	8'2"	2.5 m	8'2"	3.0 m	9'10"	2.5 m	8'2"	3.0 m	9'10"
	m	ft	m	ft	m	ft	m	ft	m	ft	m	ft	m	ft
<b>A</b>	6.10	20'0"	6.10	20'0"	6.06	19'11"	6.45	21'2"	6.69	21'11"	6.10	20'0"	6.33	20'9"
<b>B</b>	8.18	26'10"	8.17	26'10"	8.21	26'11"	8.11	26'7"	8.56	28'1"	8.17	26'10"	8.62	28'3"
<b>C</b>	5.54	18'2"	5.54	18'2"	5.58	18'4"	5.19	17'0"	5.69	18'8"	5.54	18'2"	6.04	19'9"
<b>D</b>	4.91	16'1"	4.84	15'1"	5.05	16'7"	4.59	15'1"	4.96	16'3"	4.84	15'1"	5.20	17'0"
<b>E</b>	5.34	17'6"	5.33	17'6"	5.37	17'7"	4.98	16'4"	5.51	18'1"	5.33	17'6"	5.86	19'2"
<b>F</b>	—	—	—	—	—	—	—	—	—	—	—	—	—	—
<b>G</b>	8.49	27'10"	8.49	27'8"	8.51	27'11"	8.85	29'0"	9.07	29'9"	8.49	27'8"	8.71	28'6"

\*With 4.65 m (15'3") Reach Boom.

Stick	314E CR, 314E LCR				314E LCR VA				314E CR POB, 314E LCR POB			
	2.5 m	8'2"	2.8 m	9'2"	3.0 m	9'10"	2.1 m	6'10"	2.5 m	8'2"	2.13 m	6'11"
	m	ft	m	ft	m	ft	m	ft	m	ft	m	ft
<b>A</b>	6.86	22'6"	7.03	23'1"	7.19	23'7"	7.01	23'0"	7.40	24'3"	6.02	19'9"
<b>B</b>	8.23	27'0"	8.49	27'10"	8.68	28'6"	7.98	26'2"	8.36	27'5"	7.27	23'10"
<b>C</b>	5.45	17'11"	5.75	18'10"	5.95	19'6"	4.81	15'9"	5.21	17'1"	4.84	15'11"
<b>D</b>	4.88	16'0"	5.09	16'8"	5.28	17'4"	3.92	12'10"	4.34	14'3"	3.55	11'8"
<b>E</b>	5.16	16'11"	5.46	17'11"	5.66	18'7"	4.68	15'4"	5.09	16'8"	4.45	14'7"
<b>F</b>	—	—	—	—	—	—	—	—	—	—	—	—
<b>G</b>	9.31	30'7"	9.48	31'1"	9.64	31'8"	9.43	30'11"	9.81	32'2"	8.45	27'9"

POB = Parallel Offset Boom

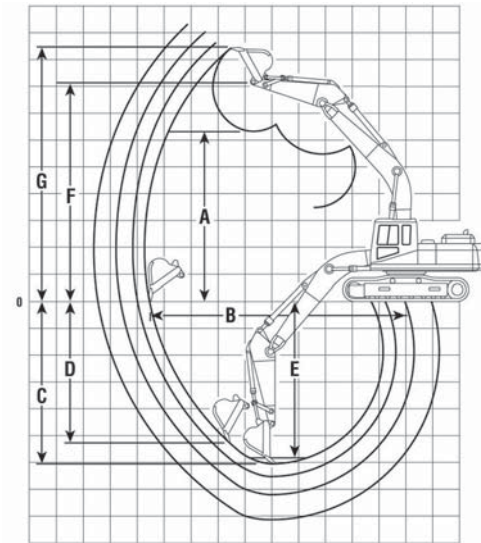

**One-Piece and VA Booms  
 Digging Envelope**

- Standard shoes and undercarriage

**KEY:**

- A** Maximum loading height of bucket with teeth
- B** Maximum reach at ground level
- C** Maximum digging depth
- D** Maximum vertical wall
- E** Maximum depth of cut for 2.44 m (8'0") level bottom (straight clean up)
- F** Maximum bucket hinge pin height
- G** Maximum height, to bucket teeth at highest arc

**316E L Reach Boom**

Stick	2.25 m	7'4"	2.6 m	8'6"	2.9 m	9'6"	3.1 m	10'2"
	mm	ft	mm	ft	mm	ft	mm	ft
<b>A</b>	6110	20'1"	6280	20'7"	6270	20'7"	6570	21'7"
<b>B</b>	8460	27'9"	8780	28'10"	8990	29'6"	9260	30'5"
<b>C</b>	5740	18'11"	6090	20'0"	6390	21'10"	6590	21'7"
<b>D</b>	4490	14'8"	4930	16'2"	4910	16'1"	5400	17'9"
<b>E</b>	5500	18'0"	5870	19'3"	6160	20'3"	6400	21'0"
<b>F</b>	—	—	—	—	—	—	—	—
<b>G</b>	8740	28'8"	8920	29'3"	8880	29'2"	9210	30'3"

**316E L VA Boom**

**318D2 L**

Stick	2.25 m	7'6"	2.6 m	8'6"	2.9 m	8'6"	2.6 m	9'6"
	mm	ft	mm	ft	m	ft	m	ft
<b>A</b>	7550	24'9"	7870	25'10"	6.27	20'7"	6.28	20'7"
<b>B</b>	8640	28'4"	8970	29'5"	8.99	29'6"	8.78	28'10"
<b>C</b>	5170	17'0"	5510	18'1"	6.39	21'0"	6.09	20'0"
<b>D</b>	4100	13'5"	4480	14'8"	4.91	16'1"	4.93	16'3"
<b>E</b>	5030	16'6"	5390	17'8"	6.16	20'3"	5.87	19'3"
<b>F</b>	—	—	—	—	—	—	—	—
<b>G</b>	10 250	33'8"	10 560	34'8"	8.88	29'2"	8.92	29'3"

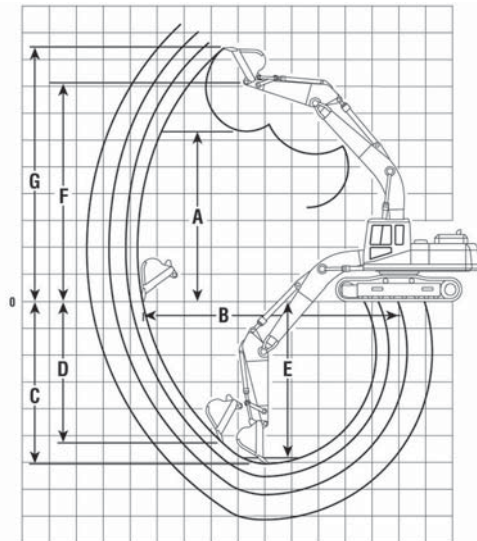

**One-Piece and VA Booms  
Digging Envelope**

- Standard shoes and undercarriage

**KEY:**

- A** Maximum loading height of bucket with teeth
- B** Maximum reach at ground level
- C** Maximum digging depth
- D** Maximum vertical wall
- E** Maximum depth of cut for 2.44 m (8'0") level bottom (straight clean up)
- F** Maximum bucket hinge pin height
- G** Maximum height, to bucket teeth at highest arc

**318E L Reach Boom**

**318E L VA Boom**

Stick	2.25 m		2.6 m		2.9 m		3.1 m		2.25 m		2.6 m	
	mm	ft	mm	ft	mm	ft	mm	ft	mm	ft	mm	ft
<b>A</b>	6120	20'1"	6280	20'7"	6280	20'7"	6570	21'7"	7550	24'9"	7870	25'10"
<b>B</b>	8460	27'9"	8780	28'10"	8990	29'6"	9260	30'5"	8630	28'4"	8970	29'5"
<b>C</b>	5740	18'11"	6090	20'0"	6390	21'10"	6590	21'7"	5160	16'11"	5510	18'1"
<b>D</b>	4480	14'8"	4920	16'2"	4900	16'1"	5390	17'9"	4090	13'5"	4480	14'8"
<b>E</b>	5490	18'0"	5860	19'3"	6150	20'3"	6400	21'0"	5020	16'6"	5380	17'8"
<b>F</b>	—	—	—	—	—	—	—	—	—	—	—	—
<b>G</b>	8750	28'8"	8930	29'3"	8880	29'2"	9220	30'3"	10 260	33'8"	10 560	34'8"

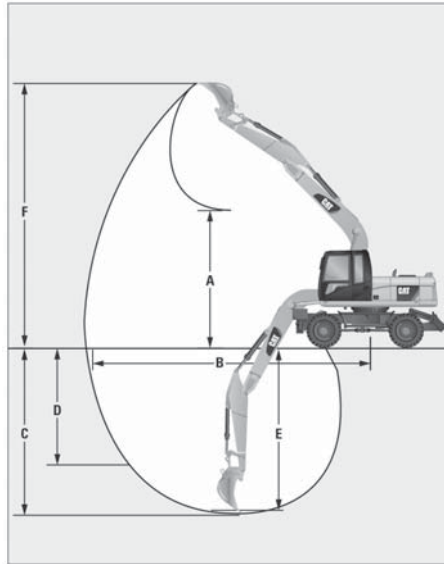

**One-Piece Boom  
Digging Envelope**

- Standard dual 10.00-20 tires and undercarriage
- General purpose bucket

**KEY:**

- A** Maximum loading height of bucket with teeth
- B** Maximum reach at ground level
- C** Maximum digging depth
- D** Maximum vertical wall
- E** Maximum depth of cut for 2.5 m (8'2") level bottom (straight clean up)
- F** Maximum height, to bucket teeth at highest arc

**M313D†**

**M315D†**

Stick	2 m 6'7"		2.3 m 7'7"		2.6 m 8'6"		2.1 m 6'11"		2.4 m 7'10"		2.6 m 8'6"	
	0.715 m <sup>3</sup> 0.94 yd <sup>3</sup>		0.64 m <sup>3</sup> 0.84 yd <sup>3</sup>		0.64 m <sup>3</sup> 0.84 yd <sup>3</sup>		0.815 m <sup>3</sup> 1.07 yd <sup>3</sup>		0.7 m <sup>3</sup> 0.92 yd <sup>3</sup>		0.7 m <sup>3</sup> 0.92 yd <sup>3</sup>	
Bucket	m	ft	m	ft	m	ft	m	ft	m	ft	m	ft
<b>A</b>	5.91	19'5"	5.97	19'7"	6.14	20'2"	6.00	19'8"	6.11	20'0"	6.23	20'5"
<b>B</b>	8.23	27'0"	8.48	27'10"	8.77	28'10"	8.71	28'7"	8.97	29'5"	9.17	30'1"
<b>C</b>	4.99	16'4"	5.29	17'4"	5.59	18'4"	5.39	17'8"	5.69	18'8"	5.89	19'4"
<b>D</b>	3.41	11'2"	3.37	11'1"	3.67	12'0"	3.51	11'6"	3.65	12'0"	3.82	12'6"
<b>E</b>	4.75	15'7"	5.07	16'8"	5.39	17'8"	5.17	16'11"	5.49	18'0"	5.70	18'8"
<b>F</b>	8.60	28'2"	8.62	28'3"	8.79	28'10"	8.98	29'5"	9.07	29'9"	9.19	30'2"

†This product has been discontinued.

**M315D2**

**M316D†**

Stick	2 m 6'7"		2.3 m 7'7"		2.6 m 8'6"		2.1 m 6'11"		2.4 m 7'10"		2.6 m 8'6"	
	0.7 m <sup>3</sup> 0.92 yd <sup>3</sup>		0.7 m <sup>3</sup> 0.92 yd <sup>3</sup>		0.7 m <sup>3</sup> 0.92 yd <sup>3</sup>		0.815 m <sup>3</sup> 1.07 yd <sup>3</sup>		0.815 m <sup>3</sup> 1.07 yd <sup>3</sup>		0.7 m <sup>3</sup> 0.92 yd <sup>3</sup>	
Bucket	mm	ft	mm	ft	mm	ft	m	ft	m	ft	m	ft
<b>A</b>	6060	19'11"	6120	20'1"	6300	20'8"	6.02	19'9"	6.13	20'1"	6.25	20'6"
<b>B</b>	8080	26'6"	8320	27'4"	8610	28'3"	8.71	28'7"	8.97	29'5"	9.17	30'1"
<b>C</b>	4840	15'11"	5140	16'10"	5440	17'10"	5.37	17'7"	5.67	18'7"	5.87	19'3"
<b>D</b>	3750	12'4"	3740	12'3"	4040	13'3"	3.49	11'5"	3.63	11'11"	3.80	12'6"
<b>E</b>	4590	15'1"	4910	16'1"	5230	17'2"	5.15	16'11"	5.47	17'11"	5.68	18'8"
<b>F</b>	8480	27'10"	8510	27'11"	8690	28'6"	9.00	29'6"	9.09	29'10"	9.21	30'3"

†This product has been discontinued.



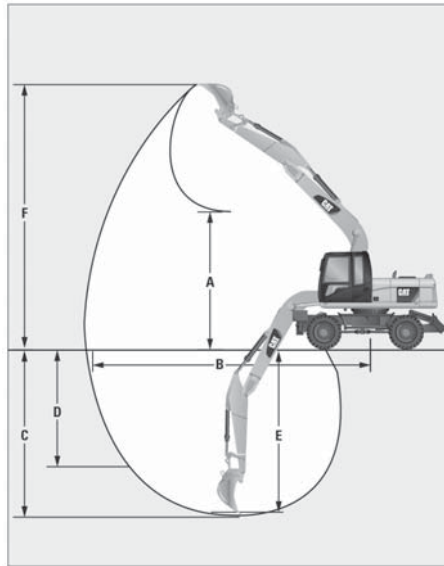

**One-Piece Boom  
Digging Envelope**

- Standard dual 10.00-20 tires and undercarriage for M317D2, M318D and M320D2
- Standard dual 11.00-20 tires and undercarriage for M322D
- General purpose bucket

**KEY:**

- A** Maximum loading height of bucket with teeth
- B** Maximum reach at ground level
- C** Maximum digging depth
- D** Maximum vertical wall
- E** Maximum depth of cut for 2.5 m (8'2") level bottom (straight clean up)
- F** Maximum height, to bucket teeth at highest arc

**M317D2**

**M318D†**

Stick	2.1 m	6'11"	2.4 m	7'10"	2.6 m	8'6"	2.2 m	7'3"	2.5 m	8'2"	2.8 m	9'2"
Bucket	0.8 m <sup>3</sup>	1.05 yd <sup>3</sup>	0.8 m <sup>3</sup>	1.05 yd <sup>3</sup>	0.8 m <sup>3</sup>	1.05 yd <sup>3</sup>	0.91 m <sup>3</sup>	1.19 yd <sup>3</sup>	0.91 m <sup>3</sup>	1.19 yd <sup>3</sup>	0.7 m <sup>3</sup>	0.92 yd <sup>3</sup>
	mm	ft	mm	ft	mm	ft	m	ft	m	ft	m	ft
<b>A</b>	6150	20'2"	6260	20'6"	6370	20'11"	5.90	19'4"	6.11	20'0"	6.27	20'7"
<b>B</b>	8560	28'1"	8830	29'0"	9020	29'7"	9.00	29'6"	9.32	30'7"	9.60	31'6"
<b>C</b>	5240	17'2"	5540	18'2"	5740	18'10"	5.70	18'8"	6.00	19'8"	6.30	20'8"
<b>D</b>	4080	13'5"	4240	13'11"	4410	14'6"	2.88	9'5"	3.34	10'11"	3.62	11'10"
<b>E</b>	5010	16'5"	5330	17'6"	5540	18'2"	5.49	18'0"	5.81	19'0"	6.12	20'1"
<b>F</b>	8880	29'2"	8970	29'5"	9090	29'10"	8.76	28'9"	9.01	29'7"	9.17	30'1"

†This product has been discontinued.

**M320D2**

**M322D†**

Stick	2.2 m	7'3"	2.5 m	8'2"	2.8 m	9'2"	2.2 m	7'3"	2.5 m	8'2"	2.9 m	9'6"
Bucket	0.9 m <sup>3</sup>	1.18 yd <sup>3</sup>	0.9 m <sup>3</sup>	1.18 yd <sup>3</sup>	0.7 m <sup>3</sup>	0.92 yd <sup>3</sup>	1.04 m <sup>3</sup>	1.36 yd <sup>3</sup>	0.805 m <sup>3</sup>	1.05 yd <sup>3</sup>	0.805 m <sup>3</sup>	1.05 yd <sup>3</sup>
	mm	ft	mm	ft	mm	ft	m	ft	m	ft	m	ft
<b>A</b>	6050	19'10"	6270	20'7"	6420	21'1"	6.30	20'8"	6.23	20'5"	6.45	21'2"
<b>B</b>	8850	29'0"	9160	30'1"	9450	31'0"	9.72	31'11"	9.93	32'7"	10.32	33'10"
<b>C</b>	5550	18'3"	5850	19'2"	6150	20'2"	5.77	18'11"	6.07	19'11"	6.47	21'3"
<b>D</b>	3660	12'0"	4120	13'6"	4420	14'6"	4.48	14'8"	4.78	15'8"	5.16	16'11"
<b>E</b>	5340	17'6"	5650	18'6"	5960	19'7"	5.57	18'3"	5.88	19'3"	6.30	20'8"
<b>F</b>	8660	28'5"	8910	29'3"	9060	29'9"	9.67	31'9"	9.54	31'3"	9.76	32'0"

†This product has been discontinued.

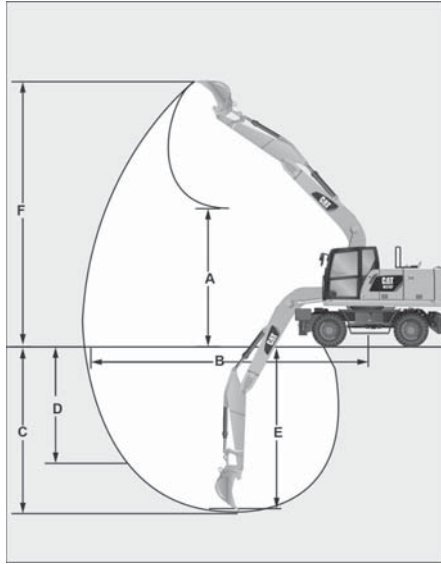

**One-Piece Boom  
Digging Envelope**

- Standard dual 10.00-20 tires and undercarriage
- General purpose bucket

**KEY:**

- A** Maximum loading height of bucket with teeth
- B** Maximum reach at ground level
- C** Maximum digging depth
- D** Maximum vertical wall
- E** Maximum depth of cut for 2.5 m (8'2'') level bottom (straight clean up)
- F** Maximum height, to bucket teeth at highest arc

**M314F**

**M316F**

Stick	2.0 m 6'7"		2.3 m 7'7"		2.6 m 8'6"		2.1 m 6'11"		2.4 m 7'10"		2.6 m 8'6"	
	0.68 m <sup>3</sup>	0.89 yd <sup>3</sup>	0.68 m <sup>3</sup>	0.89 yd <sup>3</sup>	0.68 m <sup>3</sup>	0.89 yd <sup>3</sup>	0.8 m <sup>3</sup>	1.05 yd <sup>3</sup>	0.8 m <sup>3</sup>	1.05 yd <sup>3</sup>	0.8 m <sup>3</sup>	1.05 yd <sup>3</sup>
Bucket	mm	ft	mm	ft	mm	ft	mm	ft	mm	ft	mm	ft
<b>A</b>	2800	9'2"	2485	8'2"	2185	7'2"	2760	9'1"	2450	8'0"	2250	7'5"
<b>B</b>	8080	26'6"	8325	27'4"	8615	28'3"	8560	28'1"	8820	28'11"	9020	29'7"
<b>C</b>	4840	15'11"	5140	16'10"	5440	17'10"	5240	17'2"	5540	18'2"	5740	18'10"
<b>D</b>	3900	12'10"	3885	12'9"	4190	13'9"	4300	14'1"	4470	14'8"	4640	15'3"
<b>E</b>	4590	15'1"	4900	16'1"	5230	17'2"	5010	16'5"	5330	17'6"	5540	18'2"
<b>F</b>	8420	27'7"	8435	27'8"	8615	28'3"	8820	28'11"	8910	29'3"	9030	29'8"

**M318F**

**M320F**

Stick	2.1 m 6'11"		2.4 m 7'10"		2.6 m 8'6"		2.5 m 8'2"		2.8 m 9'2"	
	0.8 m <sup>3</sup>	1.05 yd <sup>3</sup>	0.8 m <sup>3</sup>	1.05 yd <sup>3</sup>	0.8 m <sup>3</sup>	1.05 yd <sup>3</sup>	0.9 m <sup>3</sup>	1.18 yd <sup>3</sup>	0.7 m <sup>3</sup>	0.92 yd <sup>3</sup>
Bucket	mm	ft	mm	ft	mm	ft	mm	ft	mm	ft
<b>A</b>	6170	20'3"	6280	20'7"	6400	21'0"	6140	20'2"	6290	20'8"
<b>B</b>	8560	28'1"	8820	28'11"	9020	29'7"	9220	30'3"	9505	31'2"
<b>C</b>	5220	17'2"	5520	18'1"	5720	18'9"	5910	19'5"	6210	20'4"
<b>D</b>	4280	14'1"	4450	14'7"	4620	15'2"	4360	14'4"	4660	15'3"
<b>E</b>	4990	16'4"	5310	17'5"	5520	18'1"	5675	18'7"	5995	19'8"
<b>F</b>	8840	29'0"	8930	29'4"	9050	29'8"	8890	29'2"	9040	29'8"

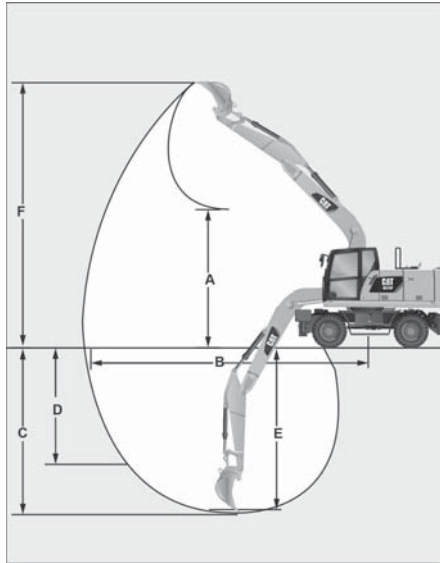

**One-Piece Boom  
Digging Envelope**

- Standard dual 11.00-20 tires and undercarriage
- General purpose bucket

**KEY:**

- 
- A** Maximum loading height of bucket with teeth
  - B** Maximum reach at ground level
  - C** Maximum digging depth
  - D** Maximum vertical wall
  - E** Maximum depth of cut for 2.5 m (8'2") level bottom (straight clean up)
  - F** Maximum height, to bucket teeth at highest arc
- 

**M322F**

	2.2 m		2.5 m		2.9 m	
	7'3"	7'3"	8'2"	8'2"	9'6"	9'6"
Stick	2.2 m	7'3"	2.5 m	8'2"	2.9 m	9'6"
Bucket	1.19 m <sup>3</sup>	1.56 yd <sup>3</sup>	1.19 m <sup>3</sup>	1.56 yd <sup>3</sup>	1.19 m <sup>3</sup>	1.56 yd <sup>3</sup>
	mm	ft	mm	ft	mm	ft
A	2810	9'3"	2520	8'3"	2120	6'11"
B	9550	31'4"	9770	32'1"	10 160	33'4"
C	5615	18'5"	5915	19'5"	6315	20'9"
D	5095	16'9"	4840	15'11"	5225	17'2"
E	5400	17'9"	5715	18'9"	6135	20'2"
F	9415	30'11"	9255	30'4"	9480	31'1"

- 320E
- 320E L
- 320E RR
- 320E LRR
- 320F L
- 323D2 L
- 320D2
- 320D2 L
- 320D2 GC

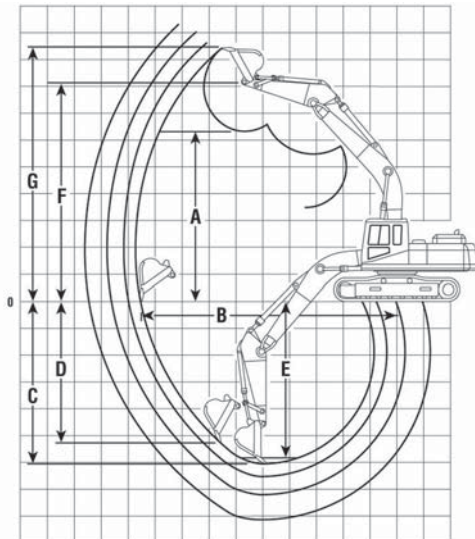

### One-Piece Boom Digging Envelope

- Standard shoes and undercarriage

#### KEY:

- A** Maximum loading height of bucket with teeth
- B** Maximum reach at ground level
- C** Maximum digging depth
- D** Maximum vertical wall
- E** Maximum depth of cut for 2.44 m (8'0") level bottom (straight clean up)
- F** Maximum bucket hinge pin height
- G** Maximum height, to bucket teeth at highest arc

Stick	320D2, 320D2 L with Reach Boom				320D2 GC with Reach Boom		320E, 320E L, 320E RR, 320E LRR with Reach Boom			
	2.5 m	8'2"	2.9 m	9'6"	2.9 m	9'6"	2.9 m	9'6"	2.5 m	7'6"
	m	ft	m	ft	m	ft	mm	ft	mm	ft
<b>A</b>	6.36	20'10"	6.56	21'6"	6.57	21'7"	6490	21'4"	6300	20'8"
<b>B</b>	9.40	30'1"	9.79	32'1"	9.78	32'1"	9860	30'9"	9450	31'0"
<b>C</b>	6.24	20'6"	6.66	21'1"	6.64	21'9"	6720	22'1"	6290	20'8"
<b>D</b>	5.60	18'4"	6.01	19'7"	6.01	19'9"	5060	16'7"	5210	17'1"
<b>E</b>	6.04	19'1"	6.48	21'3"	6.47	21'3"	6550	21'6"	6100	20'0"
<b>F</b>	7.87	25'9"	8.06	26'5"	—	—	—	—	—	—
<b>G</b>	9.24	30'4"	9.45	31'0"	9.44	31'0"	9370	30'7"	9240	30'4"

Stick	320E L with Super Long Reach		320F L with Reach Boom		323D2 L with Reach Boom		323D2 L with Mass Boom	
	6.28 m	20'6"	2.9 m	9'6"	2.5 m	8'2"	2.9 m	9'6"
	mm	ft	m	ft	m	ft	m	ft
<b>A</b>	11 290	37'0"	6.49	21'4"	6.29	20'8"	6.49	21'4"
<b>B</b>	15 720	51'6"	9.86	32'4"	9.63	31'7"	9.86	32'4"
<b>C</b>	11 690	38'4"	6.72	22'1"	6.30	20'8"	6.72	22'1"
<b>D</b>	10 670	35'0"	5.06	16'7"	5.65	18'6"	5.69	18'8"
<b>E</b>	11 590	38'0"	6.55	21'6"	5.96	19'7"	6.38	20'11"
<b>F</b>	—	—	—	—	—	—	—	—
<b>G</b>	13 590	44'6"	9.37	30'9"	9.29	30'6"	9.49	31'0"

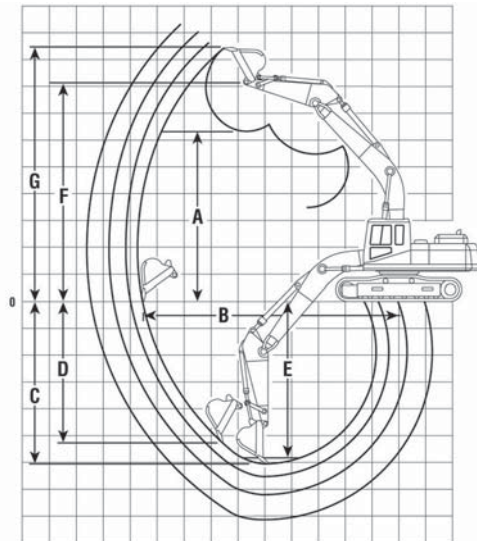

**One-Piece and VA Booms  
Digging Envelope**

- Standard shoes and undercarriage

**KEY:**

- A** Maximum loading height of bucket with teeth
- B** Maximum reach at ground level
- C** Maximum digging depth
- D** Maximum vertical wall
- E** Maximum depth of cut for 2.44 m (8'0") level bottom (straight clean up)
- F** Maximum bucket hinge pin height
- G** Maximum height, to bucket teeth at highest arc

**323F L  
with Reach Boom**

**323F L  
with VA Boom**

Stick	3.9 m		2.9 m		2.5 m		2.9 m		2.5 m	
	mm	ft	mm	ft	mm	ft	mm	ft	mm	ft
<b>A</b>	7030	23'1"	6490	21'4"	6300	20'8"	8410	27'7"	8070	26'6"
<b>B</b>	10 680	35'0"	9860	32'4"	9450	31'0"	10 200	33'6"	9800	32'2"
<b>C</b>	7580	24'10"	6720	22'1"	6290	20'8"	6680	21'11"	6270	20'7"
<b>D</b>	6910	22'8"	5060	16'7"	5210	17'1"	5290	17'4"	4890	16'1"
<b>E</b>	7440	24'5"	6550	21'6"	6100	20'0"	6580	21'7"	6170	20'3"
<b>F</b>	—	—	—	—	—	—	—	—	—	—
<b>G</b>	9890	32'5"	9370	30'9"	9240	30'4"	11 520	37'10"	11 180	36'8"

**323F L with  
Super Long Reach**

**323F LN  
with Reach Boom**

**323F LN  
with VA Boom**

Stick	6.28 m		2.9 m		2.5 m		2.9 m		2.5 m	
	mm	ft	m	ft	m	ft	m	ft	m	ft
<b>A</b>	11 290	37'0"	6.50	21'4"	6.30	20'8"	8.41	27'7"	8.07	26'6"
<b>B</b>	15 720	51'7"	9.85	32'4"	9.45	31'0"	10.20	33'6"	9.80	32'2"
<b>C</b>	11 690	38'4"	6.71	22'0"	6.29	20'8"	6.68	21'11"	6.27	20'7"
<b>D</b>	10 670	35'0"	5.69	18'8"	5.29	17'4"	5.34	17'6"	4.94	16'2"
<b>E</b>	11 280	37'0"	6.54	21'5"	6.10	20'0"	6.58	21'7"	6.17	20'3"
<b>F</b>	—	—	—	—	—	—	—	—	—	—
<b>G</b>	13 590	44'7"	9.45	31'0"	9.24	30'3"	11.52	37'10"	11.18	36'8"

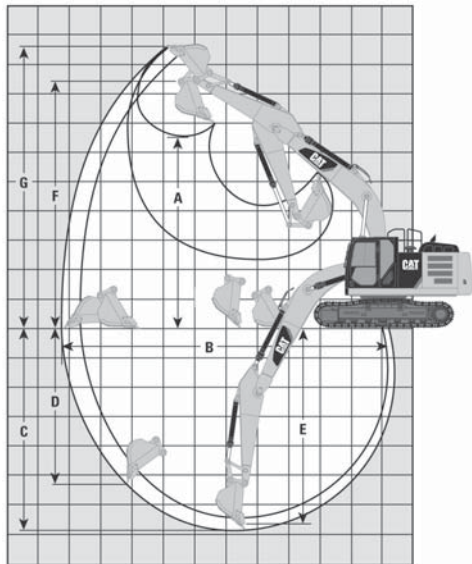

**One-Piece and VA Booms  
Digging Envelope**

- Standard shoes and undercarriage

**KEY:**

- A** Maximum loading height of bucket with teeth
- B** Maximum reach at ground level
- C** Maximum digging depth
- D** Maximum vertical wall
- E** Maximum depth of cut for 2.44 m (8'0") level bottom (straight clean up)
- F** Maximum bucket hinge pin height
- G** Maximum height, to bucket teeth at highest arc

**325F L  
with 5.7 m (18'8")  
Reach Boom**

**325F L with VA Boom  
[2.8 m (9'2") Stub +  
3.3 m (10'10") Fore]**

**326D2 L  
with Reach Boom**

Stick	2.9 m		9'6"		2.9 m		9'6"		2.5 m		8'2"		2.95 m		9'8"	
	m	ft	m	ft	m	ft	m	ft	m	ft	m	ft	m	ft	m	ft
<b>A</b>	7.89	25'11"	8.54	28'0"	6.39	21'0"	6.59	21'7"								
<b>B</b>	9.79	32'1"	10.13	33'3"	9.74	31'11"	10.15	33'4"								
<b>C</b>	6.71	22'0"	6.51	21'4"	6.40	21'0"	6.85	22'6"								
<b>D</b>	5.00	16'5"	5.17	17'0"	4.98	16'4"	5.41	17'9"								
<b>E</b>	6.54	21'5"	6.42	21'1"	6.20	20'4"	6.67	21'11"								
<b>F</b>	—	—	—	—	—	—	—	—								
<b>G</b>	10.96	35'11"	11.65	38'3"	9.50	32'2"	9.70	31'1"								

**326F L, 326F LN  
with 5.9 m (19'4") Reach Boom**

**326F L, 326F LN  
with 5.6 m (18'4") VA Boom**

Stick	2.5 m		8'2"		2.95 m		9'8"		2.95 m		9'8"	
	m	ft	m	ft	m	ft	m	ft	m	ft	m	ft
<b>A</b>	6.44	21'2"	7.45	24'5"	8.32	27'4"						
<b>B</b>	9.69	31'9"	10.11	33'2"	10.34	33'11"						
<b>C</b>	6.36	20'10"	6.81	22'4"	6.69	21'11"						
<b>D</b>	4.87	16'0"	5.30	17'5"	5.10	16'9"						
<b>E</b>	6.16	20'3"	6.64	21'9"	6.59	21'7"						
<b>F</b>	9.617	31'7"	9.956	32'8"	9.97	32'9"						
<b>G</b>	9.49	31'2"	9.69	31'9"	11.60	38'1"						

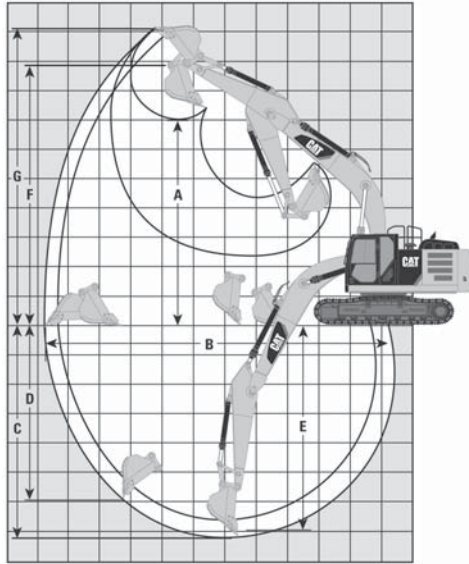

**One-Piece Boom  
Digging Envelope**

- Standard shoes and undercarriage

**KEY:**

- A** Maximum loading height of bucket with teeth
- B** Maximum reach at ground level
- C** Maximum digging depth
- D** Maximum vertical wall
- E** Maximum depth of cut for 2.44 m (8'0") level bottom (straight clean up)
- F** Maximum bucket hinge pin height
- G** Maximum height, to bucket teeth at highest arc

**330F L, 330F LN  
with 6.15 m (20'2")  
Reach Boom**

**335F L  
with 6.15 m (20'3")  
Reach Boom**

Stick	2.65 m		3.2 m		3.75 m		2.65 m		3.2 m	
	mm	ft	mm	ft	mm	ft	m	ft	m	ft
<b>A</b>	6800	22'4"	6950	22'10"	7140	23'4"	7.75	25'5"	7.97	26'2"
<b>B</b>	10 200	33'6"	10 680	35'0"	11 180	36'7"	10.16	33'4"	10.64	34'11"
<b>C</b>	6700	22'0"	7250	23'9"	7800	25'6"	6.44	21'2"	6.99	22'11"
<b>D</b>	5680	18'8"	5980	19'7"	6420	21'1"	5.46	17'11"	5.77	18'11"
<b>E</b>	6520	21'5"	7090	23'3"	7660	25'1"	6.26	20'6"	6.83	22'5"
<b>F</b>	8450	27'9"	8600	28'3"	8790	28'10"	—	—	—	—
<b>G</b>	9900	32'6"	10 010	32'10"	10 190	33'4"	10.95	35'11"	11.15	36'7"

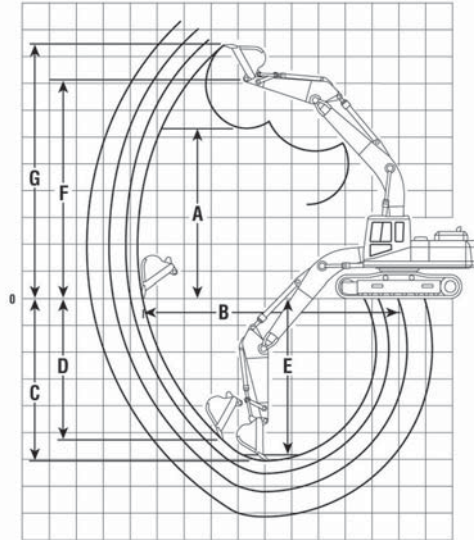

**One-Piece Boom  
Digging Envelope**

- Standard shoes and undercarriage

**KEY:**

- A** Maximum loading height of bucket with teeth
- B** Maximum reach at ground level
- C** Maximum digging depth
- D** Maximum vertical wall
- E** Maximum depth of cut for 2.44 m (8'0") level bottom (straight clean up)
- F** Maximum bucket hinge pin height
- G** Maximum height, to bucket teeth at highest arc

**336D, 336D L  
with Reach Boom**

**336D, 336D L  
with Mass Boom**

Stick	2.15 m		3.2 m		3.9 m		2.15 m		2.55 m	
	m	ft	m	ft	m	ft	m	ft	m	ft
<b>A</b>	6.53	21'5"	7.20	23'7"	7.64	25'1"	6.41	21'0"	6.69	21'11"
<b>B</b>	10.07	33'0"	10.92	35'10"	11.64	38'2"	9.76	32'0"	10.18	33'5"
<b>C</b>	6.50	21'4"	7.39	24'3"	8.09	26'7"	6.17	20'3"	6.57	21'7"
<b>D</b>	4.80	15'9"	5.83	19'2"	6.70	13'0"	4.71	15'5"	5.34	17'6"
<b>E</b>	6.28	20'7"	7.23	23'9"	7.96	26'1"	5.97	19'7"	6.40	21'0"
<b>F</b>	8.35	27'5"	—	—	—	—	8.23	27'0"	—	—
<b>G</b>	9.82	32'3"	10.71	33'7"	10.71	35'22"	9.74	31'11"	10.07	33'0"

**336D2 GC with  
Reach Boom**

**336D2 XE, 336D2 L XE  
with Reach Boom**

**336D2 XE, 336D2 L XE  
with Mass Boom**

Stick	2.8 m		2.8 m		3.2 m		3.9 m		2.15 m		2.55 m	
	m	ft	m	ft	m	ft	m	ft	m	ft	m	ft
<b>A</b>	7.08	23'3"	7.08	23'3"	7.08	23'3"	7.51	24'8"	6.31	20'8"	6.60	21'8"
<b>B</b>	10.75	35'3"	10.75	35'3"	11.05	36'3"	11.76	38'7"	9.85	32'4"	10.28	33'9"
<b>C</b>	7.11	23'4"	7.11	23'4"	7.51	24'8"	8.21	26'1"	6.27	20'7"	6.67	21'1"
<b>D</b>	5.40	17'9"	5.40	17'9"	5.42	17'9"	6.29	20'8"	4.06	13'4"	4.70	15'5"
<b>E</b>	6.95	22'1"	6.95	22'1"	7.36	24'2"	8.08	26'6"	6.06	19'1"	6.49	21'4"
<b>F</b>	—	—	—	—	—	—	—	—	—	—	—	—
<b>G</b>	10.32	33'1"	10.32	33'1"	10.25	33'8"	10.73	35'2"	9.64	31'8"	9.99	32'9"



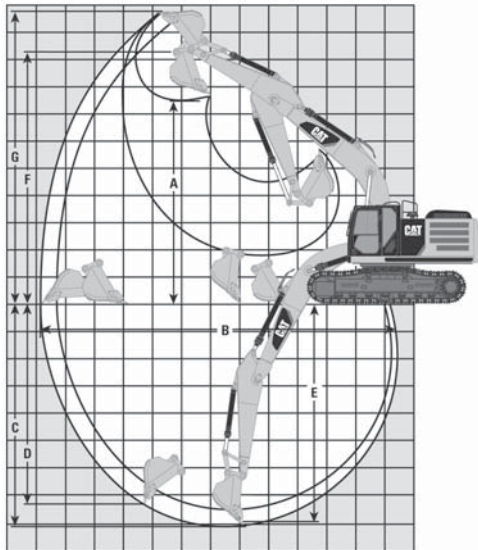

**One-Piece Boom  
Digging Envelope**

- Standard shoes and undercarriage

**KEY:**

- 
- A** Maximum loading height of bucket with teeth
  - B** Maximum reach at ground level
  - C** Maximum digging depth
  - D** Maximum vertical wall
  - E** Maximum depth of cut for 2.44 m (8'0") level bottom (straight clean up)
  - F** Maximum bucket hinge pin height
  - G** Maximum height, to bucket teeth at highest arc
- 

**336E L, 336E LN, 336E L H, 336E LN H  
with Reach Boom**

**336E L, 336E LN  
with Mass Boom**

Stick	2.8 m		3.2 m		3.9 m		2.15 m		2.55 m	
	m	ft	m	ft	m	ft	m	ft	m	ft
<b>A</b>	7.11	23'4"	7.11	23'4"	7.50	24'7"	6.34	20'10"	6.62	21'9"
<b>B</b>	10.71	35'2"	11.02	36'2"	11.72	38'5"	9.83	32'3"	10.26	33'8"
<b>C</b>	7.09	23'3"	7.49	24'7"	8.19	26'10"	6.25	20'6"	6.65	21'10"
<b>D</b>	5.47	17'11"	5.50	18'1"	6.31	20'8"	3.81	13'6"	4.45	14'7"
<b>E</b>	6.39	21'0"	6.82	22'5"	7.61	25'0"	5.28	17'4"	5.81	19'1"
<b>F</b>	8.89	29'2"	8.90	29'2"	9.29	30'5"	8.26	27'1"	8.54	28'1"
<b>G</b>	10.37	34'0"	10.32	33'10"	10.74	35'3"	9.63	31'7"	9.97	32'9"

**336F L  
with Reach Boom**

**336F L  
with Mass Boom**

Stick	2.8 m		3.2 m		3.9 m		2.15 m		2.55 m	
	m	ft	m	ft	m	ft	m	ft	m	ft
<b>A</b>	7.11	23'4"	7.11	23'4"	7.50	24'7"	6.34	20'10"	6.62	21'9"
<b>B</b>	10.71	35'2"	11.02	36'2"	11.70	38'5"	9.83	32'3"	10.26	33'8"
<b>C</b>	7.09	23'3"	7.49	24'7"	8.19	26'10"	6.25	20'6"	6.65	21'10"
<b>D</b>	5.47	17'11"	5.50	18'1"	6.31	20'8"	3.81	13'6"	4.45	14'7"
<b>E</b>	6.39	21'0"	6.82	22'5"	7.61	25'0"	5.28	17'4"	5.81	19'1"
<b>F</b>	8.89	29'2"	8.90	29'2"	9.29	30'5"	8.26	27'1"	8.54	28'1"
<b>G</b>	10.37	34'0"	10.32	33'10"	10.74	35'3"	9.63	31'7"	9.97	32'9"

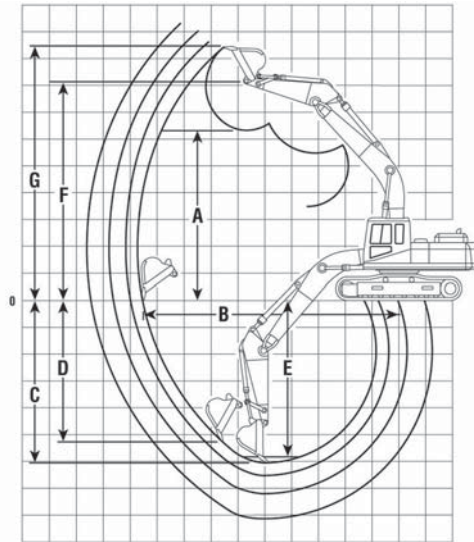

**One-Piece Boom Digging Envelope**

- Standard shoes and undercarriage

**KEY:**

- A** Maximum loading height of bucket with teeth
- B** Maximum reach at ground level
- C** Maximum digging depth
- D** Maximum vertical wall
- E** Maximum depth of cut for 2.44 m (8'0") level bottom (straight clean up)
- F** Maximum bucket hinge pin height
- G** Maximum height, to bucket teeth at highest arc

Stick	340D2 L with Reach Boom				340D2 L with Mass Boom				340F L with Reach Boom			
	2.8 m	9'2"	3.2 m	10'6"	2.15 m	7'1"	2.55 m	8'4"	2.8 m	9'2"	3.2 m	10'6"
	m	ft	m	ft	m	ft	m	ft	m	ft	m	ft
<b>A</b>	7.00	23'0"	7.00	23'0"	6.27	20'7"	6.55	21'6"	7.34	24'1"	7.34	24'1"
<b>B</b>	10.83	35'6"	11.13	36'6"	9.89	32'5"	10.32	33'1"	10.67	35'0"	10.97	36'0"
<b>C</b>	7.19	23'7"	7.59	24'1"	6.31	20'8"	6.71	22'0"	6.86	22'6"	7.26	23'1"
<b>D</b>	5.46	17'1"	5.48	18'0"	4.06	13'4"	4.70	15'5"	5.24	17'2"	5.27	17'3"
<b>E</b>	6.37	20'1"	6.79	22'3"	5.27	17'3"	5.80	19'0"	6.16	20'3"	6.59	21'7"
<b>F</b>	—	—	—	—	—	—	—	—	—	—	—	—
<b>G</b>	10.33	33'1"	10.25	33'8"	9.63	31'7"	9.98	32'9"	10.60	34'9"	10.55	34'7"

Stick	340F L with Mass Boom		349D2 L with Reach Boom		349D2 L with Mass Boom		3 m		9'10"	
	2.8 m	9'2"	3.35 m	11'0"	3.9 m	12'10"	2.5 m	8'2"	m	ft
	m	ft	m	ft	m	ft	m	ft	m	ft
<b>A</b>	6.85	22'6"	7.47	24'6"	7.45	24'5"	6.62	21'9"	6.81	22'4"
<b>B</b>	10.21	33'6"	11.66	38'3"	12.08	39'8"	10.71	35'2"	11.18	36'8"
<b>C</b>	6.42	21'1"	7.60	24'11"	8.15	26'9"	6.72	22'1"	7.22	23'8"
<b>D</b>	4.22	13'1"	6.30	20'8"	6.46	21'2"	4.92	16'2"	5.38	17'8"
<b>E</b>	5.58	18'4"	7.46	24'6"	8.02	26'4"	6.55	21'6"	7.07	23'2"
<b>F</b>	—	—	9.29	30'6"	9.28	30'5"	8.64	28'4"	8.83	29'0"
<b>G</b>	10.20	33'6"	10.80	35'5"	10.71	35'2"	10.23	33'7"	10.42	34'2"

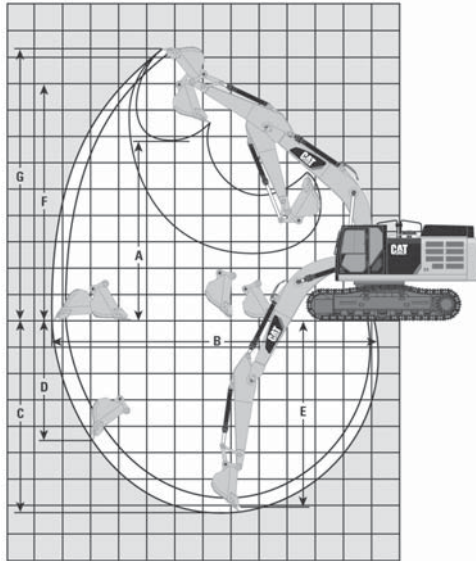

**One-Piece Booms  
Digging Envelope**

- Standard shoes and undercarriage

**KEY:**

- A** Maximum loading height of bucket with teeth
- B** Maximum reach at ground level
- C** Maximum digging depth
- D** Maximum vertical wall
- E** Maximum depth of cut for 2.44 m (8'0") level bottom (straight clean up)
- F** Maximum bucket hinge pin height
- G** Maximum height, to bucket teeth at highest arc

Stick	349F L with Long Reach Boom		349F L with Reach Boom		349F L with Mass Boom		349F L with Long Reach Boom		349F L with Mass Boom	
	4.3 m mm	14'1" ft	3.9 m mm	12'10" ft	3.35 m mm	11'0" ft	3 m mm	9'10" ft	2.5 m mm	8'2" ft
<b>A</b>	7870	25'10"	7420	24'4"	7430	24'5"	6740	22'1"	6550	21'6"
<b>B</b>	12 960	42'6"	12 150	39'10"	11 730	38'6"	11 270	37'0"	10 810	35'6"
<b>C</b>	8940	29'4"	8210	26'11"	7660	25'2"	7310	24'0"	6810	22'4"
<b>D</b>	6560	21'6"	5960	19'7"	5830	19'2"	4430	14'6"	4000	13'1"
<b>E</b>	8810	28'11"	8080	26'6"	7520	24'8"	7160	23'6"	6640	21'9"
<b>F</b>	—	—	—	—	—	—	—	—	—	—
<b>G</b>	11 170	36'8"	10 730	35'2"	10 820	35'6"	10 290	33'9"	10 090	33'1"

Stick	352F with Long Reach Boom		352F with Reach Boom		352F with Mass Boom		352F with Long Reach Boom		352F with Mass Boom	
	4.3 m mm	14'1" ft	3.9 m mm	12'10" ft	3.35 m mm	11'0" ft	3 m mm	9'10" ft	2.5 m mm	8'2" ft
<b>A</b>	8020	26'4"	7570	24'10"	7580	24'10"	6900	22'8"	6700	22'0"
<b>B</b>	12 940	42'5"	12 120	39'9"	11 710	38'5"	11 240	36'11"	10 770	35'4"
<b>C</b>	8790	28'10"	8060	26'5"	7510	24'8"	7150	23'5"	6650	21'10"
<b>D</b>	6400	21'0"	5810	19'1"	5680	18'8"	4280	14'1"	3850	12'8"
<b>E</b>	8660	28'5"	7920	26'0"	7360	24'2"	7010	23'0"	6490	21'4"
<b>F</b>	—	—	—	—	—	—	—	—	—	—
<b>G</b>	11 320	37'2"	10 880	35'8"	10 970	36'0"	10 440	34'3"	10 250	33'8"

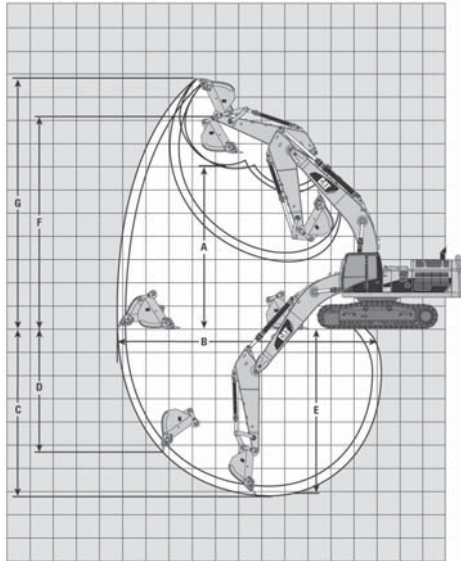

**One-Piece Boom  
Digging Envelope**

- Standard shoes and undercarriage
- Lug height not included

**KEY:**

- A** Maximum loading height of bucket with teeth
- B** Maximum reach at ground level
- C** Maximum digging depth
- D** Maximum vertical wall
- E** Maximum depth of cut for 2.44 m (8'0") level bottom (straight clean up)
- F** Maximum bucket hinge pin height
- G** Maximum height, to bucket teeth at highest arc

**374F L with Reach Boom**

Stick	2.84 m	9'4"	3.6 m	11'10"	4.15 m	13'7"	4.67 m	15'4"
Bucket	GD3.8 m <sup>3</sup>	5.0 yd <sup>3</sup>	GD3.8 m <sup>3</sup>	5.0 yd <sup>3</sup>	GD3.8 m <sup>3</sup>	5.0 yd <sup>3</sup>	GD3.8 m <sup>3</sup>	5.0 yd <sup>3</sup>
	m	ft	m	ft	m	ft	m	ft
<b>A</b>	8.24	27'0"	8.41	27'7"	8.64	28'4"	9.00	29'6"
<b>B</b>	12.53	41'1"	13.17	43'2"	13.69	44'11"	14.23	46'8"
<b>C</b>	7.83	25'8"	8.59	28'2"	9.13	29'11"	9.65	31'8"
<b>D</b>	6.66	21'10"	7.13	23'5"	7.84	25'9"	8.53	28'0"
<b>E</b>	7.68	25'2"	8.46	27'9"	9.02	29'7"	9.55	31'4"
<b>F</b>	10.50	34'5"	10.66	35'0"	10.89	35'9"	11.25	36'11"
<b>G</b>	12.45	40'10"	12.44	40'10"	12.82	42'1"	13.21	43'4"

**374F L with Mass Boom**

Stick	2.57 m	8'5"	3 m	9'10"
Bucket	SDV4.6 m <sup>3</sup>	6.0 yd <sup>3</sup>	SDV4.6 m <sup>3</sup>	6.0 yd <sup>3</sup>
	m	ft	m	ft
<b>A</b>	7.07	23'2"	7.24	23'9"
<b>B</b>	11.46	37'7"	11.85	38'11"
<b>C</b>	7.23	23'9"	7.65	25'1"
<b>D</b>	4.04	13'3"	4.41	14'6"
<b>E</b>	7.07	23'2"	7.51	24'8"
<b>F</b>	9.37	30'9"	9.53	31'3"
<b>G</b>	11.01	36'2"	11.18	36'8"

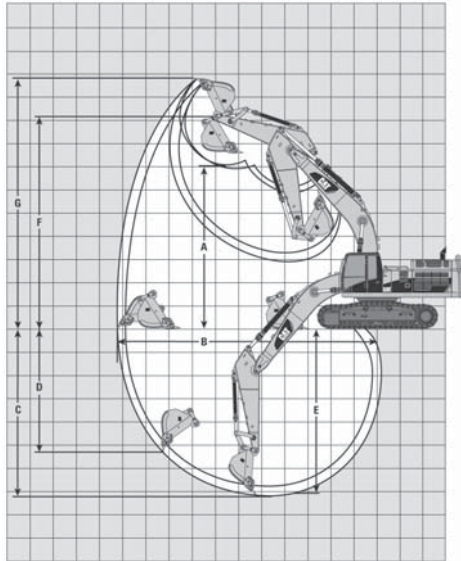

**One-Piece Boom  
Digging Envelope**

- Standard shoes and undercarriage
- Lug height not included

**KEY:**

- 
- A** Maximum loading height of bucket with teeth
  - B** Maximum reach at ground level
  - C** Maximum digging depth
  - D** Maximum vertical wall
  - E** Maximum depth of cut for 2.44 m (8'0") level bottom (straight clean up)
  - F** Maximum bucket hinge pin height
  - G** Maximum height, to bucket teeth at highest arc
- 

**390F L with  
Reach Boom**

**390F L with  
General Purpose Boom**

Stick	4.4 m	14'5"	5.5 m	18'1"	2.92 m	9'7"	3.4 m	11'2"	3.7 m	12'2"
Bucket	GD3.9 m <sup>3</sup>	5.1 yd <sup>3</sup>	GD3.9 m <sup>3</sup>	5.1 yd <sup>3</sup>	SD4.6 m <sup>3</sup>	6.0 yd <sup>3</sup>	SD4.6 m <sup>3</sup>	6.0 yd <sup>3</sup>	SD4.6 m <sup>3</sup>	6.0 yd <sup>3</sup>
	m	ft	m	ft	mm	ft	m	ft	m	ft
<b>A</b>	10.53	34'7"	10.96	36'0"	8.92	29'3"	9.10	29'10"	8.99	29'6"
<b>B</b>	16.23	53'3"	17.25	56'7"	13.48	44'3"	13.91	45'8"	14.04	46'1"
<b>C</b>	10.70	35'1"	11.80	39'9"	8.21	26'11"	8.68	28'6"	8.95	29'4"
<b>D</b>	7.38	24'3"	8.38	27'6"	5.95	19'6"	6.18	20'3"	5.93	19'6"
<b>E</b>	10.59	34'9"	11.70	38'5"	8.07	26'6"	8.55	28'1"	8.83	29'0"
<b>F</b>	12.94	42'5"	13.37	43'10"	—	—	11.54	37'10"	11.40	37'5"
<b>G</b>	14.74	48'4"	15.17	49'9"	—	—	13.46	44'2"	13.19	43'3"

**390F L with  
General Purpose Boom**

**390F L with  
Mass Boom**

Stick	4.4 m	14'5"	5.5 m	18'1"	2.92 m	9'7"	3.4 m	11'2"
Bucket	GD4.6 m <sup>3</sup>	6.0 yd <sup>3</sup>	GD4.6 m <sup>3</sup>	6.0 yd <sup>3</sup>	SDV6.0 m <sup>3</sup>	7.8 yd <sup>3</sup>	SDV6.0 m <sup>3</sup>	7.8 yd <sup>3</sup>
	m	ft	m	ft	m	ft	m	ft
<b>A</b>	9.28	30'5"	9.73	31'11"	7.99	26'3"	8.21	26'11"
<b>B</b>	14.69	48'2"	15.73	51'7"	12.24	40'2"	12.69	41'8"
<b>C</b>	9.65	31'8"	10.75	35'3"	7.16	23'6"	7.64	25'1"
<b>D</b>	6.85	22'6"	7.86	25'9"	4.69	15'5"	5.09	16'8"
<b>E</b>	9.54	31'4"	10.65	34'11"	7.02	23'0"	7.51	24'8"
<b>F</b>	11.69	38'4"	12.15	39'10"	10.48	34'5"	10.70	35'1"
<b>G</b>	13.53	44'5"	13.99	45'11"	12.35	40'6"	12.57	41'3"

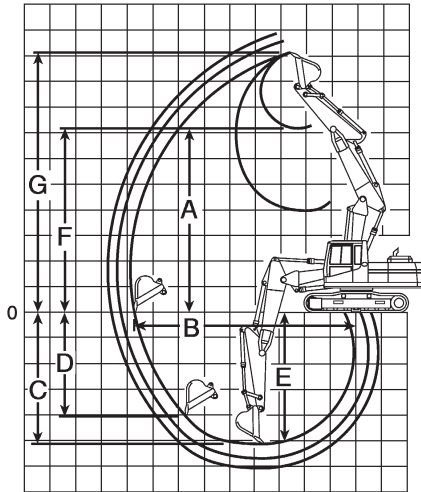

**Hydraulically Adjustable Boom  
Digging Envelope**

**KEY:**

- A** Maximum loading height of bucket with teeth
- B** Maximum reach at ground level
- C** Maximum digging depth
- D** Maximum vertical wall
- E** Maximum depth of cut for 2.44 m (8'0") level bottom (straight clean up)
- F** Maximum bucket hinge pin height
- G** Maximum height, to bucket teeth at highest arc

**312D, 312D L**

Stick	2.1 m		6'11"		2.5 m		8'2"		3 m		9'10"	
	m	ft	m	ft	m	ft	m	ft	m	ft	m	ft
<b>A</b>	6.91	22'8"	7.27	23'10"	7.65	25'1"						
<b>B</b>	7.84	25'8"	8.22	27'0"	8.68	28'6"						
<b>C</b>	4.73	15'6"	5.13	16'10"	5.61	18'5"						
<b>D</b>	2.84	9'4"	3.16	10'5"	3.64	11'11"						
<b>E</b>	4.54	14'11"	4.9	16'1"	5.34	17'6"						
<b>F</b>	8.03	26'4"	8.36	27'5"	8.77	28'10"						
<b>G</b>	9.14	30'0"	9.49	31'1"	9.89	32'5"						

**315D L**

Stick	1.85 m		6'1"		2.25 m		7'5"		2.6 m		8'6"		3.1 m		10'2"	
	m	ft	m	ft	m	ft	m	ft	m	ft	m	ft	m	ft	m	ft
<b>A</b>	6.92	22'8"	7.26	23'10"	7.45	24'5"	7.81	25'7"								
<b>B</b>	7.97	26'2"	8.36	27'5"	8.68	28'6"	9.10	29'10"								
<b>C</b>	4.65	15'4"	5.06	16'7"	5.40	17'8"	5.85	19'2"								
<b>D</b>	3.12	10'2"	3.52	11'7"	3.88	12'8"	4.36	14'4"								
<b>E</b>	4.59	15'0"	4.99	16'5"	5.34	17'6"	5.81	19'1"								
<b>F</b>	8.21	26'11"	8.54	28'0"	8.77	28'10"	9.10	29'11"								
<b>G</b>	9.49	31'1"	9.82	32'2"	10.09	33'1"	10.40	34'1"								

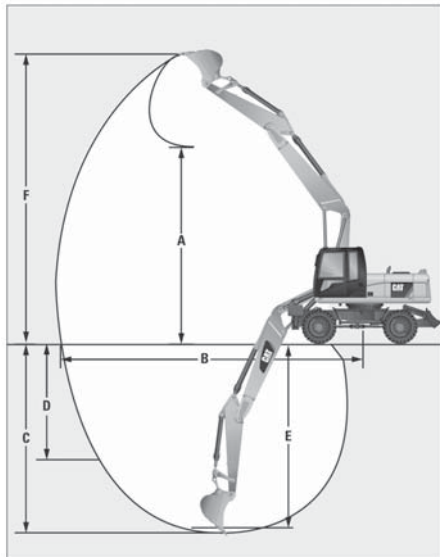

**Hydraulically Adjustable Boom  
Digging Envelope**

- Standard dual 10.00-20 tires and undercarriage
- General purpose bucket

**KEY:**

- 
- A** Maximum loading height of bucket with teeth
  - B** Maximum reach at ground level
  - C** Maximum digging depth
  - D** Maximum vertical wall
  - E** Maximum depth of cut for 2.5 m (8'2") level bottom
  - F** Maximum height, to bucket teeth at highest arc
- 

**M313D†**

**M315D†**

Stick	2 m 6'7"		2.3 m 7'7"		2.6 m 8'6"		2.1 m 6'11"		2.4 m 7'10"		2.6 m 8'6"	
	0.64 m <sup>3</sup> 0.84 yd <sup>3</sup>		0.64 m <sup>3</sup> 0.84 yd <sup>3</sup>		0.56 m <sup>3</sup> 0.73 yd <sup>3</sup>		0.815 m <sup>3</sup> 1.07 yd <sup>3</sup>		0.7 m <sup>3</sup> 0.92 yd <sup>3</sup>		0.7 m <sup>3</sup> 0.92 yd <sup>3</sup>	
Bucket	m	ft	m	ft	m	ft	m	ft	m	ft	m	ft
<b>A</b>	6.90	22'8"	7.06	23'2"	7.29	23'11"	6.95	22'10"	7.14	23'5"	7.30	23'11"
<b>B</b>	8.49	27'10"	8.74	28'8"	9.03	29'7"	8.91	29'3"	9.19	30'2"	9.38	30'9"
<b>C</b>	5.16	16'11"	5.45	17'11"	5.75	18'10"	5.59	18'4"	5.89	19'4"	6.09	20'0"
<b>D</b>	3.50	11'6"	3.60	11'10"	3.89	12'9"	3.72	12'2"	3.92	12'10"	4.09	13'5"
<b>E</b>	4.92	16'2"	5.23	17'2"	5.55	18'2"	5.37	17'7"	5.69	18'8"	5.90	19'4"
<b>F</b>	9.67	31'9"	9.82	32'3"	10.06	33'0"	10.04	32'11"	10.23	33'7"	10.38	34'1"

†This product has been discontinued.

**M315D2**

**M316D†**

Stick	2 m 6'7"		2.3 m 7'7"		2.6 m 8'6"		2.1 m 6'11"		2.4 m 7'10"		2.6 m 8'6"	
	0.7 m <sup>3</sup> 0.92 yd <sup>3</sup>		0.7 m <sup>3</sup> 0.92 yd <sup>3</sup>		0.7 m <sup>3</sup> 0.92 yd <sup>3</sup>		0.815 m <sup>3</sup> 1.07 yd <sup>3</sup>		0.815 m <sup>3</sup> 1.07 yd <sup>3</sup>		0.7 m <sup>3</sup> 0.92 yd <sup>3</sup>	
Bucket	mm	ft	mm	ft	mm	ft	m	ft	m	ft	m	ft
<b>A</b>	7060	23'2"	7210	23'8"	7440	24'5"	6.97	22'10"	7.16	23'6"	7.32	24'0"
<b>B</b>	8330	27'4"	8580	28'2"	8880	29'2"	8.91	29'3"	9.19	30'2"	9.38	30'9"
<b>C</b>	5010	16'5"	5300	17'5"	5600	18'4"	5.57	18'3"	5.87	19'3"	6.07	19'11"
<b>D</b>	3680	12'1"	3810	12'6"	4100	13'5"	3.70	12'2"	3.90	12'10"	4.07	13'4"
<b>E</b>	4760	15'7"	5070	16'8"	5390	17'8"	5.35	17'7"	5.67	18'7"	5.88	19'3"
<b>F</b>	9520	31'3"	9670	31'9"	9910	32'6"	10.06	33'0"	10.25	33'7"	10.40	34'1"

†This product has been discontinued.

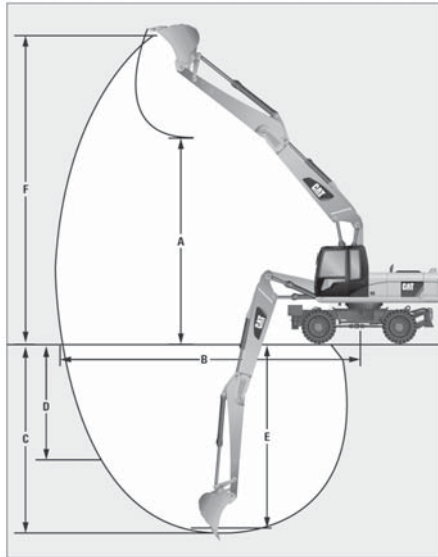

**Hydraulically Adjustable Boom  
Digging Envelope**

- Standard dual 10.00-20 tires and undercarriage for M317D2, M318D and M320D2
- Standard dual 11.00-20 tires and undercarriage for M322D
- General purpose bucket

**KEY:**

- A** Maximum loading height of bucket with teeth
- B** Maximum reach at ground level
- C** Maximum digging depth
- D** Maximum vertical wall
- E** Maximum depth of cut for 2.5 m (8'2") level bottom
- F** Maximum height, to bucket teeth at highest arc

	<b>M317D2</b>						<b>M318D†</b>					
Stick	2.1 m	6'11"	2.4 m	7'10"	2.6 m	8'6"	2.2 m	7'3"	2.5 m	8'2"	2.8 m	9'2"
Bucket	0.8 m <sup>3</sup>	1.05 yd <sup>3</sup>	0.8 m <sup>3</sup>	1.05 yd <sup>3</sup>	0.8 m <sup>3</sup>	1.05 yd <sup>3</sup>	0.91 m <sup>3</sup>	1.19 yd <sup>3</sup>	0.91 m <sup>3</sup>	1.19 yd <sup>3</sup>	0.7 m <sup>3</sup>	0.92 yd <sup>3</sup>
	mm	ft	mm	ft	mm	ft	m	ft	m	ft	m	ft
<b>A</b>	7100	23'4"	7280	23'11"	7440	24'5"	6.70	22'0"	6.97	22'10"	7.19	23'7"
<b>B</b>	8770	28'9"	9040	29'8"	9240	30'4"	8.97	29'5"	9.30	30'6"	9.59	31'5"
<b>C</b>	5450	17'11"	5740	18'10"	5930	19'5"	5.75	18'10"	6.06	19'11"	6.36	20'10"
<b>D</b>	4070	13'4"	4280	14'1"	4460	14'7"	3.22	10'7"	3.68	12'1"	3.96	13'0"
<b>E</b>	5220	17'2"	5530	18'2"	5740	18'10"	5.54	18'2"	5.87	19'3"	6.18	20'3"
<b>F</b>	9910	32'6"	10 090	33'1"	10 250	33'8"	9.71	31'10"	10.00	32'10"	10.21	33'6"

†This product has been discontinued.

	<b>M320D2</b>						<b>M322D†</b>					
Stick	2.2 m	7'3"	2.5 m	8'2"	2.8 m	9'2"	2.2 m	7'3"	2.5 m	8'2"	2.9 m	9'6"
Bucket	0.9 m <sup>3</sup>	1.18 yd <sup>3</sup>	0.9 m <sup>3</sup>	1.18 yd <sup>3</sup>	0.7 m <sup>3</sup>	0.92 yd <sup>3</sup>	1.04 m <sup>3</sup>	1.36 yd <sup>3</sup>	0.805 m <sup>3</sup>	1.05 yd <sup>3</sup>	0.805 m <sup>3</sup>	1.05 yd <sup>3</sup>
	mm	ft	mm	ft	mm	ft	m	ft	m	ft	m	ft
<b>A</b>	6850	22'6"	7120	23'4"	7330	24'1"	6.93	22'9"	7.17	23'6"	7.50	24'7"
<b>B</b>	8820	28'11"	9140	30'0"	9430	30'11"	9.59	31'5"	9.83	32'3"	10.23	33'7"
<b>C</b>	5600	18'4"	5900	19'4"	6200	20'4"	5.99	19'8"	6.28	20'7"	6.68	21'11"
<b>D</b>	3920	12'10"	4290	14'1"	4580	15'0"	4.42	14'6"	4.45	14'7"	4.83	15'10"
<b>E</b>	5390	17'8"	5700	18'8"	6010	19'9"	5.78	19'0"	6.09	20'0"	6.51	21'4"
<b>F</b>	9580	31'5"	9870	32'5"	10 080	33'1"	10.56	34'8"	10.62	34'10"	10.93	35'10"

†This product has been discontinued.



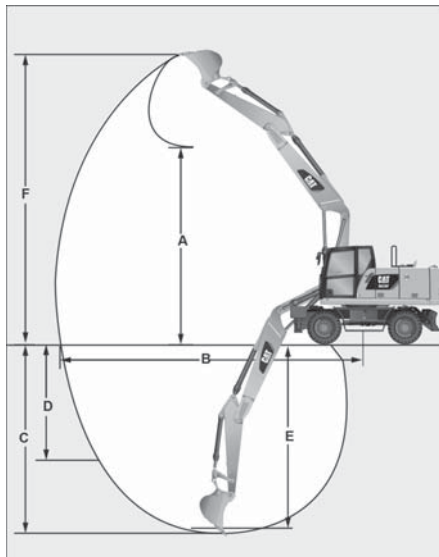

**Hydraulically Adjustable Boom  
Digging Envelope**

- Standard dual 10.00-20 tires and undercarriage for M316D and M318D
- Standard dual 11.00-20 tires and undercarriage for M322D
- General purpose bucket

**KEY:**

- A** Maximum loading height of bucket with teeth
- B** Maximum reach at ground level
- C** Maximum digging depth
- D** Maximum vertical wall
- E** Maximum depth of cut for 2.5 m (8'2") level bottom
- F** Maximum height, to bucket teeth at highest arc

**M314F**

**M316F**

Stick	2.0 m	6'7"	2.3 m	7'7"	2.6 m	8'6"	2.1 m	6'11"	2.4 m	7'10"	2.6 m	8'6"
	0.68 m <sup>3</sup>	0.89 yd <sup>3</sup>	0.68 m <sup>3</sup>	0.89 yd <sup>3</sup>	0.68 m <sup>3</sup>	0.89 yd <sup>3</sup>	0.8 m <sup>3</sup>	1.05 yd <sup>3</sup>	0.8 m <sup>3</sup>	1.05 yd <sup>3</sup>	0.8 m <sup>3</sup>	1.05 yd <sup>3</sup>
Bucket	mm	ft	mm	ft	mm	ft	mm	ft	mm	ft	mm	ft
<b>A</b>	3550	11'8"	3210	10'6"	2930	9'7"	3440	11'3"	3120	10'3"	2940	9'8"
<b>B</b>	8335	27'4"	8590	28'2"	8885	29'2"	8760	28'9"	9040	29'8"	9230	30'3"
<b>C</b>	5010	16'5"	5300	17'5"	5600	18'4"	5450	17'11"	5740	18'10"	5940	19'6"
<b>D</b>	3830	12'7"	3960	13'0"	4250	13'11"	4250	13'11"	4480	14'8"	4660	15'3"
<b>E</b>	4890	16'1"	5185	17'0"	5485	18'0"	5330	17'6"	5630	18'6"	5830	19'2"
<b>F</b>	9520	31'3"	9655	31'8"	9895	32'6"	8890	29'2"	10 070	33'0"	10 230	33'7"

**M318F**

**M320F**

Stick	2.1 m	6'11"	2.4 m	7'10"	2.6 m	8'6"	2.5 m	8'2"	2.8 m	9'2"
	0.8 m <sup>3</sup>	1.05 yd <sup>3</sup>	0.8 m <sup>3</sup>	1.05 yd <sup>3</sup>	0.8 m <sup>3</sup>	1.05 yd <sup>3</sup>	0.9 m <sup>3</sup>	1.18 yd <sup>3</sup>	0.7 m <sup>3</sup>	0.92 yd <sup>3</sup>
Bucket	mm	ft	mm	ft	mm	ft	mm	ft	mm	ft
<b>A</b>	7120	23'4"	7300	23'11"	7460	24'6"	6970	22'10"	7180	23'7"
<b>B</b>	8760	28'9"	9040	29'8"	9230	30'3"	9195	30'2"	9490	31'2"
<b>C</b>	5430	17'10"	5720	18'9"	5920	19'5"	5960	19'7"	6260	20'6"
<b>D</b>	4230	13'11"	4460	14'8"	4640	15'3"	4495	14'9"	4785	15'8"
<b>E</b>	5310	17'5"	5610	18'5"	5810	19'1"	5860	19'3"	6160	20'3"
<b>F</b>	9910	32'6"	10 090	33'1"	10 250	33'8"	9885	32'5"	10 100	33'2"

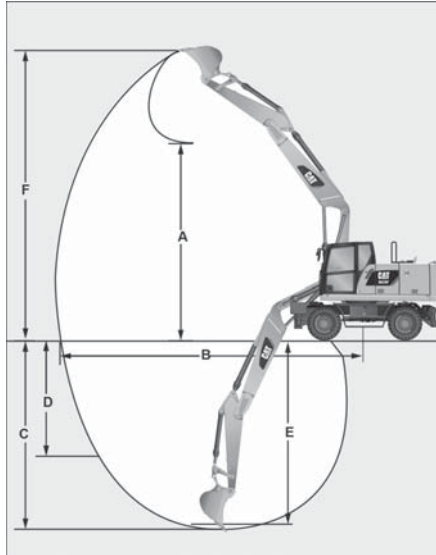

**Hydraulically Adjustable Boom  
Digging Envelope**

- Standard dual 11.00-20 tires and undercarriage
- General purpose bucket

**KEY:**

- A** Maximum loading height of bucket with teeth
- B** Maximum reach at ground level
- C** Maximum digging depth
- D** Maximum vertical wall
- E** Maximum depth of cut for 2.5 m (8'2") level bottom
- F** Maximum height, to bucket teeth at highest arc

**M322F**

Stick	2.2 m	7'3"	2.5 m	8'2"	2.9 m	9'6"
Bucket	1.19 m <sup>3</sup>	1.56 yd <sup>3</sup>	1.19 m <sup>3</sup>	1.56 yd <sup>3</sup>	1.19 m <sup>3</sup>	1.56 yd <sup>3</sup>
	mm	ft	mm	ft	mm	ft
<b>A</b>	3345	11'0"	2975	9'9"	2585	8'6"
<b>B</b>	9420	30'11"	9660	31'8"	10 055	34'7"
<b>C</b>	5825	19'1"	6115	20'1"	6515	21'4"
<b>D</b>	4545	14'11"	4570	15'0"	4940	16'2"
<b>E</b>	5720	18'9"	6020	19'9"	6425	21'1"
<b>F</b>	10 385	34'1"	10 410	34'2"	10 720	35'2"

**EXCAVATOR LIFTING CAPACITY**

On many sewer jobs an excavator must lift and swing heavy pipe and manboxes in and out of the trench, place manholes and unload material from trucks. In some situations the excavator’s lift requirements may be so critical that they determine the size excavator selected.

An excavator’s lift capacity depends on its weight, center of gravity, the lift point position (see sketches) and its hydraulic capability. An excavator’s lifting capability for any given lift position is limited by its tipping stability or hydraulic capacity.

Changes in boom, stick and bucket position affect attachment geometry and can drastically change a machine’s hydraulic lifting capacity. Caterpillar defines excavator lifting capabilities using the following SAE guidelines.

**Tipping Conditions** — An excavator is considered to be at the tipping point when the weight in the bucket acting at the center of gravity causes the rear rollers to lift clear of the track rails. Suspended loads are considered to be hung from the back of the excavator’s bucket or bucket linkage by a sling or chain. Weights of attachments, slings or auxiliary lifting devices are considered part of the suspended load.

Thus, the tipping load is defined as the load producing a tipping condition at a specified radius. The load radius shall be measured as the horizontal distance from the axis of upper structure rotation (before loading) to the center of vertical load line with load applied (dimension A, below). The rating height is based on the vertical distance of the bucket lift point to the ground (dimension B).

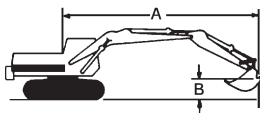

- A. Radius from swing centerline
- B. Bucket lift point height

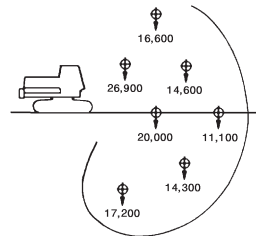

**HYPOTHETICAL MACHINE**

**Rated Hoist Load** — The rated load is established using the vertical distance of the lifting point to the ground and the radius of load. Ratings for the ability of a specific machine attachment to lift a load slung from the designated bucket are defined as follows:

- a. The rated load will not exceed 75% of the tipping load.
- b. The rated load will not exceed 87% of the excavator’s hydraulic capacity. This means the machine should be able to lift 115% of the rated load.
- c. The rated load will not exceed the machine’s structural capability.

This drawing shows how an excavator's lifting capacity can vary with load position:

**HYPOTHETICAL MACHINE**

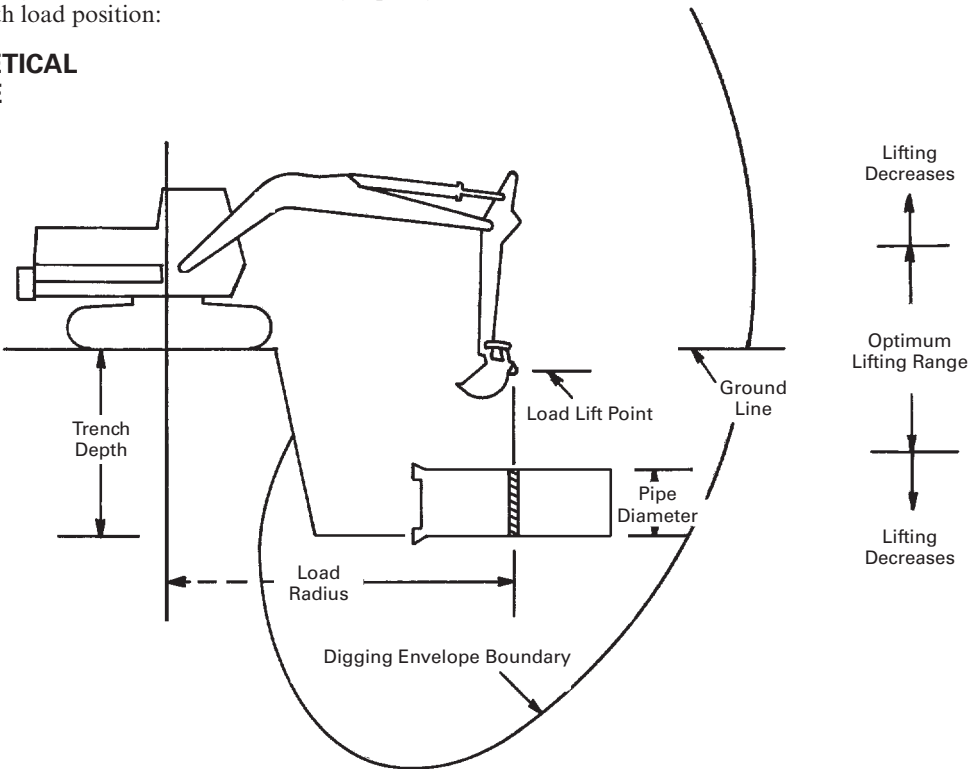

**Tips for Lifting Above Ground:**

Get the load as close to the excavator as possible.  
Use a cable short enough and position the excavator so as to put the load lift point in the "optimum lifting range" (see sketch).  
*Problem:* Long reach cable — Can't lift.  
*Solution:* Shorten reach and cable — Can lift.

**Tips for Lifting Below Grade:**

Use a cable for sufficient length to position the load lift point in the "optimum lifting range".  
*Problem:* Short cable, deep trench — Can't lift.  
*Solution:* Lengthen cable to locate bucket hinge pin in optimum lifting area — Can lift.

**GROUND LEVEL LIFTING CAPACITIES**

The lifting capacities that are shown on the following pages are with the lifting point at ground level. These capacities are rated according to SAE Std. No. J1097.  
(For lifting capacities at other heights or with other tools, refer to current Specification Sheets.)

**300.9D ● Rubber Track ● Canopy ● Blade Raised**

Stick 0.89 m 2'9"	kg lb	1 m 3'3"	1.5 m 5'0"	2 m 6'7"	2.5 m 8'2"	At Max. Reach Front
		Front	Front	Front	Front	
		570	296	197	145	137
		1257	653	434	319	303

**300.9D ● Rubber Track ● Canopy ● Blade Lowered**

Stick 0.89 m 2'9"	kg lb	1 m 3'3"	1.5 m 5'0"	2 m 6'7"	2.5 m 8'2"	At Max. Reach Front
		Front	Front	Front	Front	
		678	379	247	171	155
		1495	835	546	377	343

**301.4C ● Rubber Track ● Canopy ● Blade Raised**

Stick 1.10 m 3'6"	kg lb	1.5 m 5'0"		2 m 6'7"		2.5 m 8'2"		3 m 9'10"		At Max. Reach	
		Front	Side	Front	Side	Front	Side	Front	Side	Front	Side
Undercarriage Retracted		524	—	363	—	275	—	218	—	208	—
		1154		799		606		482		458	
Undercarriage Extended		—	—	—	—	—	—	—	—	—	—

**301.4C ● Rubber Track ● Canopy ● Blade Lowered**

Stick 1.10 m 3'6"	kg lb	1.5 m 5'0"		2 m 6'7"		2.5 m 8'2"		3 m 9'10"		At Max. Reach	
		Front	Side	Front	Side	Front	Side	Front	Side	Front	Side
Undercarriage Retracted		961	—	715	335	472	—	385	200	350	190
		2119		1576	738	1041		849	441	716	419
Undercarriage Extended		777	—	715	495	366	—	385	300	271	275
		1712		1576	1091	807		849	661	597	606

**301.7D ● Rubber Track ● Canopy ● Blade Raised**

Stick 1180 mm 3'10"	kg lb	1.5 m 5'0"		2 m 6'7"		2.5 m 8'2"		3 m 9'10"		At Max. Reach	
		Front	Side	Front	Side	Front	Side	Front	Side	Front	Side
Undercarriage Retracted		600	573	400	387	296	289	232	227	198	195
		1323	1263	882	853	653	637	511	500	437	430
Undercarriage Extended		600	883	400	569	296	416	232	324	198	277
		1323	1947	882	1254	653	917	511	714	437	611

**301.7D ● Rubber Track ● Canopy ● Blade Lowered**

Stick 1180 mm 3'10"	kg lb	1.5 m 5'0"		2 m 6'7"		2.5 m 8'2"		3 m 9'10"		At Max. Reach	
		Front	Side	Front	Side	Front	Side	Front	Side	Front	Side
Undercarriage Retracted		1271	573	793	387	573	289	454	227	393	195
		2802	1263	1748	853	1263	637	1001	500	866	430
Undercarriage Extended		1271	883	793	569	573	416	454	324	393	277
		2802	1947	1748	1254	1263	917	1001	714	866	611

**301.7D CR ● Rubber Track ● Canopy ● Blade Raised**

Stick 1.10 m 3'6"	kg lb	1.5 m 5'0"		2 m 6'7"		2.5 m 8'2"		3 m 9'10"		At Max. Reach	
		Front	Side	Front	Side	Front	Side	Front	Side	Front	Side
Undercarriage Extended		—	—	336	373	240	269	182	206	144	165
				742	823	529	594	400	454	317	363

**302.2D ● Undercarriage Extended**

Stick		1.5 m 5'0"		2 m 6'7"		2.5 m 8'2"		3 m 9'10"		At Max. Reach	
		Front	Side	Front	Side	Front	Side	Front	Side	Front	Side
Standard Stick	kg	—	—	887	557	639	408	501	319	420	267
	lb	—	—	1957	1228	1409	900	1104	703	925	589
Long Stick	kg	—	—	863	548	616	400	484	311	382	240
	lb	—	—	1904	1207	1359	882	1066	686	842	529

**302.4D ● Rubber Track ● Canopy ● Blade Raised**

Stick		2 m 6'7"		2.5 m 8'2"		3 m 9'10"		3.5 m 11'6"		At Max. Reach	
		Front	Side	Front	Side	Front	Side	Front	Side	Front	Side
1050 mm 3'5"	kg	600	735	428	533	329	415	—	—	276	351
	lb	1323	1620	944	1175	725	915	—	—	608	774
1250 mm 4'1"	kg	593	727	421	526	320	406	255	327	247	318
	lb	1307	1603	928	1160	705	895	562	721	545	701

**302.4D ● Rubber Track ● Canopy ● Blade Lowered**

Stick		2 m 6'7"		2.5 m 8'2"		3 m 9'10"		3.5 m 11'6"		At Max. Reach	
		Front	Side	Front	Side	Front	Side	Front	Side	Front	Side
1050 mm 3'5"	kg	1285	735	932	533	730	415	—	—	615	351
	lb	2833	1620	2055	1175	1609	915	—	—	1356	774
1250 mm 4'1"	kg	1272	727	910	526	714	406	574	327	566	318
	lb	2804	1603	2006	1160	1574	895	1265	721	1248	701

**302.7D ● Rubber Track ● Canopy ● Blade Raised**

Stick	Bucket		2 m 6'7"		2.5 m 8'2"		3 m 9'10"		3.5 m 11'6"		At Max. Reach	
			Front	Side	Front	Side	Front	Side	Front	Side	Front	Side
1100 mm 3'6"	400 mm 16"	kg	—	—	—	—	—	—	—	—	—	—
		lb	—	—	—	—	—	—	—	—	—	—
1400 mm 4'6"	400 mm 16"	kg	—	—	—	—	—	—	—	—	—	—
		lb	—	—	—	—	—	—	—	—	—	—

**302.7D ● Rubber Track ● Canopy ● Blade Lowered**

Stick	Bucket		2 m 6'7"		2.5 m 8'2"		3 m 9'10"		3.5 m 11'6"		At Max. Reach	
			Front	Side	Front	Side	Front	Side	Front	Side	Front	Side
1100 mm 3'6"	400 mm 16"	kg	—	—	965	560	730	435	585	355	510	320
		lb	—	—	2127	1235	1609	959	1290	783	1124	705
1400 mm 4'6"	400 mm 16"	kg	—	—	955	623	720	483	580	394	470	332
		lb	—	—	2127	1373	1587	1065	1278	868	1036	732

**303E CR ● Blade Raised**

Stick		2.5 m 8'2"		3 m 9'10"		3.5 m 11'6"		4 m 13'1"		4.5 m 15'0"		5 m 16'5"		At Max. Reach	
		Front	Side	Front	Side	Front	Side	Front	Side	Front	Side	Front	Side	Front	Side
1260 mm	kg	1040	910	—	—	600	530	490	430	—	—	—	—	400	360
4'2"	lb	2230	1950	—	—	1290	1140	1040	930	—	—	—	—	880	790
1560 mm	kg	1010	880	750	660	580	520	470	420	380	340	—	—	350	310
5'1"	lb	2170	1890	1600	1410	1250	1100	1000	890	820	730	—	—	770	680

**303E CR ● Blade Lowered**

Stick		2.5 m 8'2"		3 m 9'10"		3.5 m 11'6"		4 m 13'1"		4.5 m 15'0"		5 m 16'5"		At Max. Reach	
		Front	Side	Front	Side	Front	Side	Front	Side	Front	Side	Front	Side	Front	Side
1260 mm	kg	1790	1000	1170	540	1080	580	880	470	—	—	—	—	720	390
4'2"	lb	3850	2130	2579	1190	2320	1250	1890	1010	—	—	—	—	1580	860
1560 mm	kg	1820	970	1340	720	1040	560	850	460	720	370	—	—	650	340
5'1"	lb	3900	2080	2870	1550	2240	1210	1830	970	1530	800	—	—	1430	750

**303.5E CR ● Blade Raised**

Stick		2.5 m 8'2"		3 m 9'10"		3.5 m 11'6"		4 m 13'1"		4.5 m 15'0"		5 m 16'5"		At Max. Reach	
		Front	Side	Front	Side	Front	Side	Front	Side	Front	Side	Front	Side	Front	Side
1260 mm	kg	1040	910	770	680	600	530	490	430	—	—	—	—	400	360
4'2"	lb	2290	2000	1690	1490	1320	1160	1080	940	—	—	—	—	880	790
1560 mm	kg	1010	880	750	660	580	520	470	420	380	340	—	—	350	310
5'1"	lb	2220	1940	1650	1450	1270	1140	1030	920	830	750	—	—	770	680

**303.5E CR ● Blade Lowered**

Stick		2.5 m 8'2"		3 m 9'10"		3.5 m 11'6"		4 m 13'1"		4.5 m 15'0"		5 m 16'5"		At Max. Reach	
		Front	Side	Front	Side	Front	Side	Front	Side	Front	Side	Front	Side	Front	Side
1260 mm	kg	1790*	1000	1370*	740	1080*	580	880*	470	—	—	—	—	720*	390
4'2"	lb	3940*	2200	3020*	1630	2380*	1270	1940*	1030	—	—	—	—	1580*	860
1560 mm	kg	1820*	970	1340*	720	1040*	560	850*	460	720*	370	—	—	650*	340
5'1"	lb	4010*	2130	2950*	1580	2290*	1230	1870*	1010	1580*	810	—	—	1430*	750

**303.5E2 CR ● Blade Raised**

Stick		2.5 m 8'2"		3 m 9'10"		3.5 m 11'6"		4 m 13'1"		4.5 m 15'0"		5 m 16'5"		At Max. Reach	
		Front	Side	Front	Side	Front	Side	Front	Side	Front	Side	Front	Side	Front	Side
1260 mm	kg	1040	910	770	680	600	530	490	430	—	—	—	—	400	360
4'2"	lb	2290	2000	1690	1490	1320	1160	1080	940	—	—	—	—	880	790
1560 mm	kg	1010	880	750	660	580	520	470	420	380	340	—	—	350	310
5'1"	lb	2220	1940	1650	1450	1270	1140	1030	920	830	750	—	—	770	680

**303.5E2 CR ● Blade Lowered**

Stick		2.5 m 8'2"		3 m 9'10"		3.5 m 11'6"		4 m 13'1"		4.5 m 15'0"		5 m 16'5"		At Max. Reach	
		Front	Side	Front	Side	Front	Side	Front	Side	Front	Side	Front	Side	Front	Side
1260 mm	kg	1790*	1000	1370*	740	1080*	580	880*	470	—	—	—	—	720*	390
4'2"	lb	3940*	2200	3020*	1630	2380*	1270	1940*	1030	—	—	—	—	1580*	860
1560 mm	kg	1820*	970	1340*	720	1040*	560	850*	460	720*	370	—	—	650*	340
5'1"	lb	4010*	2130	2950*	1580	2290*	1230	1870*	1010	1580*	810	—	—	1430*	750

\*Load limited by hydraulic capacity rather than tipping.

**304E2 CR ● Blade Raised**

Stick		2.5 m 8'2"		3 m 9'10"		3.5 m 11'6"		4 m 13'1"		4.5 m 15'0"		5 m 16'5"		At Max. Reach	
		Front	Side	Front	Side	Front	Side	Front	Side	Front	Side	Front	Side	Front	Side
1315 mm	kg	1120	1120	830	830	650	650	530	530	440	440	—	—	420	420
4'4"	lb	2460	2460	1830	1830	1430	1430	1160	1160	970	970	—	—	920	920
1615 mm	kg	1110	1100	820	820	640	640	520	520	430	430	—	—	370	370
5'4"	lb	2440	2420	1800	1800	1410	1410	1140	1140	940	940	—	—	810	810

**304E2 CR ● Blade Lowered**

Stick		2.5 m 8'2"		3 m 9'10"		3.5 m 11'6"		4 m 13'1"		4.5 m 15'0"		5 m 16'5"		At Max. Reach	
		Front	Side	Front	Side	Front	Side	Front	Side	Front	Side	Front	Side	Front	Side
1315 mm	kg	2130*	1240	1610*	920	1260*	720	1040*	590	870*	490	—	—	740*	470
4'4"	lb	4690*	2730	3540*	2020	2770*	1580	2290*	1300	1910*	1080	—	—	1630*	1030
1615 mm	kg	2150*	1230	1570*	910	1220*	720	1000*	580	860*	480	—	—	760*	420
5'4"	lb	4740*	2710	3460*	2000	2690*	1580	2200*	1270	1890*	1050	—	—	1670*	920

**305E2 CR ● Blade Raised**

Stick		2.5 m 8'2"		3 m 9'10"		3.5 m 11'6"		4 m 13'1"		4.5 m 15'0"		5 m 16'5"		At Max. Reach	
		Front	Side	Front	Side	Front	Side	Front	Side	Front	Side	Front	Side	Front	Side
1350 mm	kg	1950	1390	1450	1070	1130	840	920	690	760	570	—	—	670	510
4'4"	lb	4290	3060	3190	2350	2490	1850	2020	1520	1670	1250	—	—	1470	1120
1750 mm	kg	1950	1390	1420	1040	1100	820	890	660	740	550	620	460	560	410
5'7"	lb	4290	3060	3130	2290	2420	1800	1960	1450	1630	1210	1360	1010	1230	900

**305E2 CR ● Blade Lowered**

Stick		2.5 m 8'2"		3 m 9'10"		3.5 m 11'6"		4 m 13'1"		4.5 m 15'0"		5 m 16'5"		At Max. Reach	
		Front	Side	Front	Side	Front	Side	Front	Side	Front	Side	Front	Side	Front	Side
1350 mm	kg	2100*	1580	2340*	1200	1820*	940	1480*	770	1260*	640	—	—	1000*	570
4'4"	lb	4630*	3480	5150*	2640	4010*	2070	3260*	1690	2770*	1410	—	—	2200*	1250
1750 mm	kg	2270*	1580	2250*	1170	1720*	920	1390*	740	1190*	620	1040*	520	870*	480
5'7"	lb	5000*	3480	4960*	2570	3790*	2020	3060*	1630	2620*	1360	2290*	1140	1910*	1050

**305.5E2 CR ● Blade Raised**

Stick		2.5 m 8'2"		3 m 9'10"		3.5 m 11'6"		4 m 13'1"		4.5 m 15'0"		5 m 16'5"		At Max. Reach	
		Front	Side	Front	Side	Front	Side	Front	Side	Front	Side	Front	Side	Front	Side
1420 mm	kg	—	—	1550	1150	1210	910	980	740	820	620	—	—	680	520
4'7"	lb	—	—	3410	2530	2660	2000	2160	1630	1800	1360	—	—	1490	1140
1820 mm	kg	2080	1490	1520	1110	1180	880	950	710	790	590	670	500	580	430
5'10"	lb	4580	3280	3350	2440	2600	1940	2090	1560	1740	1300	1470	1100	1270	940

**305.5E2 CR ● Blade Lowered**

Stick		2.5 m 8'2"		3 m 9'10"		3.5 m 11'6"		4 m 13'1"		4.5 m 15'0"		5 m 16'5"		At Max. Reach	
		Front	Side	Front	Side	Front	Side	Front	Side	Front	Side	Front	Side	Front	Side
1420 mm	kg	—	—	2590*	1290	2010*	1020	1630*	830	1380*	690	—	—	1110*	580
4'7"	lb	—	—	5710*	2840	4430*	2240	3590*	1830	3040*	1520	—	—	2440*	1270
1820 mm	kg	2270*	1690	2490*	1250	1890*	990	1530*	800	1290*	660	1140*	560	900*	480
5'10"	lb	5000*	3720	5490*	2750	4160*	2180	3370*	1760	2840*	1450	2510*	1230	1980*	1050

\*Load limited by hydraulic capacity rather than tipping.



**307E2 ● Blade Raised**

Stick		2.5 m 8'2"		3 m 9'10"		3.5 m 11'6"		4 m 13'1"		4.5 m 15'0"		5 m 16'5"		At Max. Reach	
		Front	Side	Front	Side	Front	Side	Front	Side	Front	Side	Front	Side	Front	Side
1665 mm	kg	—	—	2620	2260	2050	1790	1670	1470	1390	1230	1180	1040	1010*	930
5'6"	lb	—	—	5770	4980	4510	3940	3680	3240	3060	2710	2600	2290	2220	2050

**307E2 ● Blade Lowered**

Stick		2.5 m 8'2"		3 m 9'10"		3.5 m 11'6"		4 m 13'1"		4.5 m 15'0"		5 m 16'5"		At Max. Reach	
		Front	Side	Front	Side	Front	Side	Front	Side	Front	Side	Front	Side	Front	Side
1665 mm	kg	—	—	3640*	2580	3090*	2030	2670*	1650	2340*	1380	2070*	1170	1010*	1010*
5'6"	lb	—	—	8020*	5680	6810*	4470	5880*	3630	5150*	3040	4560*	2570	2220*	2220*

**308E2 CR SB ● 450 mm (18") Track Shoes ● Blade Lowered ● 600 mm (24") Bucket**

Stick		2 m 6'7"		3 m 9'10"		4 m 13'1"		At Max. Reach	
		Front	Side	Front	Side	Front	Side	Front	Side
1665 mm	kg	—	—	—	—	3650	1710	1880	920
5'6"	lb	—	—	—	—	7830	3680	4140	2010
2210 mm	kg	—	—	—	—	3460	1680	1640	770
7'3"	lb	—	—	—	—	7410	3620	3610	1690

**308E2 CR SB ● 600 mm (24") Track Shoes ● Blade Lowered ● 600 mm (24") Bucket**

Stick		2 m 6'7"		3 m 9'10"		4 m 13'1"		At Max. Reach	
		Front	Side	Front	Side	Front	Side	Front	Side
1665 mm	kg	—	—	3710	3060	3750	1980	2310	1200
5'6"	lb	—	—	8600	6570	8070	4270	5100	2640
2210 mm	kg	—	—	3610	2780	3540	1810	2010	960
7'3"	lb	—	—	8390	5960	7620	3900	4430	2100

\*Load limited by hydraulic capacity rather than tipping.

**Japan**

**311F L RR ● 500 mm (20") Track Shoes ● Standard Counterweight  
● Reach Boom ● No Bucket**

Stick		3 m 9'10"		4.5 m 15'0"		6 m 20'0"		7.5 m 25'0"		At Max. Reach	
		Front	Side	Front	Side	Front	Side	Front	Side	Front	Side
2250 mm	kg	7500	4650	3850	2600	2550	1750	—	—	2200*	1650
7'5"	lb	<b>16,050</b>	<b>10,000</b>	<b>8250</b>	<b>5550</b>	<b>5450</b>	<b>3750</b>	—	—	<b>4800*</b>	<b>3550</b>
2800 mm	kg	7500*	4650	3850	2600	2500	1700	—	—	1700*	1400
9'2"	lb	<b>16,100*</b>	<b>10,000</b>	<b>8250</b>	<b>5500</b>	<b>5350</b>	<b>3650</b>	—	—	<b>3700*</b>	<b>3100</b>

**311F L RR ● 500 mm (20") Track Shoes ● Standard Counterweight  
● Reach Boom ● No Bucket ● Blade Down**

Stick		3 m 9'10"		4.5 m 15'0"		6 m 20'0"		7.5 m 25'0"		At Max. Reach	
		Front	Side	Front	Side	Front	Side	Front	Side	Front	Side
2250 mm	kg	7750*	5550	4950*	3050	3750*	2050	—	—	2200*	1900
7'5"	lb	<b>16,800*</b>	<b>11,950</b>	<b>10,750*</b>	<b>6550</b>	<b>8050*</b>	<b>4400</b>	—	—	<b>4800*</b>	<b>4200</b>
2800 mm	kg	7500*	5550	4750*	3050	3600*	2000	—	—	1700*	1650
9'2"	lb	<b>16,150*</b>	<b>11,950</b>	<b>10,300*</b>	<b>6500</b>	<b>7800*</b>	<b>4350</b>	—	—	<b>3700*</b>	<b>3650</b>

7

**North America, Europe, Australia, New Zealand and Polynesia**

**311F L RR ● 500 mm (20") Track Shoes ● Heavy Duty Counterweight  
● Reach Boom ● No Bucket**

Stick		3 m 9'10"		4.5 m 15'0"		6 m 20'0"		7.5 m 25'0"		At Max. Reach	
		Front	Side	Front	Side	Front	Side	Front	Side	Front	Side
2250 mm	kg	7750*	4950	4050	2750	2650	1850	—	—	2200*	1750
7'5"	lb	<b>16,800*</b>	<b>10,650</b>	<b>8700</b>	<b>5900</b>	<b>5750</b>	<b>4000</b>	—	—	<b>4800*</b>	<b>3800</b>
2800 mm	kg	7500*	4950	4050	2750	2650	1850	—	—	1700*	1500
9'2"	lb	<b>16,150*</b>	<b>10,650</b>	<b>8700</b>	<b>5900</b>	<b>5650</b>	<b>3900</b>	—	—	<b>3700*</b>	<b>3300</b>

**311F L RR ● 500 mm (20") Track Shoes ● Heavy Duty Counterweight  
● Reach Boom ● No Bucket ● Blade Down**

Stick		3 m 9'10"		4.5 m 15'0"		6 m 20'0"		7.5 m 25'0"		At Max. Reach	
		Front	Side	Front	Side	Front	Side	Front	Side	Front	Side
2250 mm	kg	7750*	5900	4950*	3250	3750*	2150	—	—	2200*	2000
7'5"	lb	<b>16,800*</b>	<b>12,600</b>	<b>10,750*</b>	<b>6950</b>	<b>8050*</b>	<b>4650</b>	—	—	<b>4800*</b>	<b>4450</b>
2800 mm	kg	7500*	5900	4750*	3200	3600*	2150	—	—	1700*	1700
9'2"	lb	<b>16,150*</b>	<b>12,600</b>	<b>10,300*</b>	<b>6900</b>	<b>7800*</b>	<b>4600</b>	—	—	<b>3700*</b>	<b>3700</b>

\*Load limited by hydraulic capacity rather than tipping.

**Asia Pacific**

**312D2 ● 500 mm (20") Track Shoes ● Reach Boom ● No Bucket**

Stick		3 m 9'10"		4.5 m 15'0"		6 m 20'0"		7.5 m 25'0"		At Max. Reach	
		Front	Side	Front	Side	Front	Side	Front	Side	Front	Side
2500 mm	kg	6900*	5700	4550	3200	3000	2150	—	—	2450	1750
8'2"	lb	15,900*	12,200	9800	6850	6450	4600	—	—	5400	3850
3000 mm	kg	7850*	5700	4550	3150	3000	2100	—	—	2200	1600
9'10"	lb	18,150	12,200	9750	6800	6400	4550	—	—	4850	3450

**312D2 ● 500 mm (20") Track Shoes ● Reach Boom ● No Bucket ● Blade Down**

Stick		3 m 9'10"		4.5 m 15'0"		6 m 20'0"		7.5 m 25'0"		At Max. Reach	
		Front	Side	Front	Side	Front	Side	Front	Side	Front	Side
2500 mm	kg	6900*	6650	6000*	3650	4500*	2450	—	—	2600*	2050
8'2"	lb	15,900*	14,250	13,000*	7850	9750*	5300	—	—	5650*	4450
3000 mm	kg	7850*	6650	5750*	3650	4350*	2450	—	—	2300*	1850
9'10"	lb	18,150*	14,200	12,450*	7800	9400*	5250	—	—	5000*	4000

**China**

**312D2 GC ● 500 mm (20") Track Shoes ● Reach Boom ● No Bucket**

Stick		3 m 9'10"		4.5 m 15'0"		6 m 20'0"		7.5 m 25'0"		At Max. Reach	
		Front	Side	Front	Side	Front	Side	Front	Side	Front	Side
2500 mm	kg	6900*	5300	4300	2950	2850	2000	—	—	2300	1650
8'2"	lb	15,900*	11,350	9200	6350	6050	4250	—	—	5050	3600

**Middle East, Africa, CIS, Asia Pacific, South America**

**312D2 L ● 500 mm (20") Track Shoes ● Reach Boom ● No Bucket**

Stick		3 m 9'10"		4.5 m 15'0"		6 m 20'0"		7.5 m 25'0"		At Max. Reach	
		Front	Side	Front	Side	Front	Side	Front	Side	Front	Side
2500 mm	kg	6900*	5800	5300	3250	3450	2200	—	—	2600*	1800
8'2"	lb	15,900*	12,450	11,300	6950	7400	4700	—	—	5650	3950
3000 mm	kg	7850*	5800	5250	3250	3400	2150	—	—	2300*	1600
9'10"	lb	18,150*	12,450	11,300	6950	7350	4650	—	—	5000*	3550

**312D2 L ● 500 mm (20") Track Shoes ● Reach Boom ● No Bucket ● Blade Down**

Stick		3 m 9'10"		4.5 m 15'0"		6 m 20'0"		7.5 m 25'0"		At Max. Reach	
		Front	Side	Front	Side	Front	Side	Front	Side	Front	Side
2500 mm	kg	6900*	6800	6000*	3750	4500*	2500	—	—	2600*	2050
8'2"	lb	15,900*	14,550	13,000*	8000	9750*	5400	—	—	5650*	4550
3000 mm	kg	7850*	6800	5750*	3700	4350*	2500	—	—	2300*	1850
9'10"	lb	18,150*	14,550	12,450*	8000	9400*	5350	—	—	5000*	4100

\*Load limited by hydraulic capacity rather than tipping.

Europe, Australia, New Zealand and Polynesia, Japan

312E ● 500 mm (20") Track Shoes ● Reach Boom ● No Bucket

Stick		3 m 9'10"		4.5 m 15'0"		6 m 20'0"		7.5 m 25'0"		At Max. Reach	
		Front	Side	Front	Side	Front	Side	Front	Side	Front	Side
2500 mm	kg	6900*	5750	4600	3200	3050	2200	—	—	2500	1800
8'2"	lb	15,950*	12,400	9900	6950	6550	4700	—	—	5500	3950
2800 mm	kg	7500*	5750	4600	3200	3050	2150	—	—	2350	1700
9'2"	lb	17,350*	12,350	9900	6900	6500	4650	—	—	5150	3700
3000 mm	kg	7850*	5750	4600	3200	3000	2150	—	—	2250	1600
9'10"	lb	18,150*	12,350	9900	6900	6500	4600	—	—	4950	3500

312E ● 500 mm (20") Track Shoes ● Reach Boom ● No Bucket ● Blade Down

Stick		3 m 9'10"		4.5 m 15'0"		6 m 20'0"		7.5 m 25'0"		At Max. Reach	
		Front	Side	Front	Side	Front	Side	Front	Side	Front	Side
2500 mm	kg	6900*	6700	6000*	3700	4500*	2500	—	—	2600*	2050
8'2"	lb	15,950*	14,400	12,950*	7950	9700*	5350	—	—	5650*	4500
2800 mm	kg	7500*	6700	5850*	3700	4400*	2550	—	—	2500*	1950
9'2"	lb	17,350*	14,350	12,650*	7900	9500*	5300	—	—	5450*	4250
3000 mm	kg	7850*	6700	5750*	3650	4300*	2450	—	—	2300*	1850
9'10"	lb	18,150*	14,350	12,450*	7900	9350*	5300	—	—	5000*	4050

7

North America, Europe, Australia, New Zealand and Polynesia

312E L ● 500 mm (20") Track Shoes ● Reach Boom ● No Bucket

Stick		3 m 9'10"		4.5 m 15'0"		6 m 20'0"		7.5 m 25'0"		At Max. Reach	
		Front	Side	Front	Side	Front	Side	Front	Side	Front	Side
2500 mm	kg	6900*	5900	5400	3300	3500	2250	—	—	2600*	1850
8'2"	lb	15,950	12,700	11,550	7100	7550	4800	—	—	5650	4050
2800 mm	kg	7500*	5900	5350	3300	3500	2200	—	—	2500*	1750
9'2"	lb	17,350	12,650	11,500	7050	7500	4750	—	—	5450	3800
3000 mm	kg	7850*	5900	5350	3300	3500	2200	—	—	2300*	1650
9'10"	lb	18,150	12,650	11,500	7050	7450	4750	—	—	5000	3600

312E L ● 600 mm (24") Track Shoes ● Reach Boom ● No Bucket

Stick		3 m 9'10"		4.5 m 15'0"		6 m 20'0"		7.5 m 25'0"		At Max. Reach	
		Front	Side	Front	Side	Front	Side	Front	Side	Front	Side
2500 mm	kg	6900*	6000	5450	3350	3550	2250	—	—	2600*	1850
8'2"	lb	15,950	12,900	11,750	7200	7650	4900	—	—	5650	4100
2800 mm	kg	7500*	6000	5450	3350	3550	2250	—	—	2500*	1750
9'2"	lb	17,350	12,850	11,700	7200	7650	4850	—	—	5450	3850
3000 mm	kg	7850*	6000	5450	3350	3550	2250	—	—	2300*	1700
9'10"	lb	18,150	12,850	11,700	7150	7600	4800	—	—	5000	3700

312E L ● 700 mm (28") Track Shoes ● Reach Boom ● No Bucket

Stick		3 m 9'10"		4.5 m 15'0"		6 m 20'0"		7.5 m 25'0"		At Max. Reach	
		Front	Side	Front	Side	Front	Side	Front	Side	Front	Side
2500 mm	kg	6900*	6100	5550	3400	3650	2300	—	—	2600*	1900
8'2"	lb	15,950	13,150	11,950	7350	7800	4950	—	—	5650	4200
2800 mm	kg	7500*	6100	5550	3400	3600	2300	—	—	2500*	1800
9'2"	lb	17,350	13,100	11,950	7300	7800	4950	—	—	5450	3950
3000 mm	kg	7850*	6100	5550	3400	3600	2300	—	—	2300*	1700
9'10"	lb	18,150	13,100	11,950	7300	7750	4900	—	—	5000	3750

\*Load limited by hydraulic capacity rather than tipping.

**North America, Europe, Australia, New Zealand and Polynesia**

**312E L ● 500 mm (20") Track Shoes ● Reach Boom ● No Bucket ● Blade Down**

Stick		3 m 9'10"		4.5 m 15'0"		6 m 20'0"		7.5 m 25'0"		At Max. Reach	
		Front	Side	Front	Side	Front	Side	Front	Side	Front	Side
2500 mm	kg	6900*	6900*	6000*	3800	4500*	2550	—	—	2600*	2100
8'2"	lb	15,950	14,800	13,000	8150	9750	5500	—	—	5650	4650
2800 mm	kg	7500*	6900	5900*	3800	4400*	2550	—	—	2500*	2000
9'2"	lb	17,350	14,800	12,700	8150	9550	5450	—	—	5450	4350
3000 mm	kg	7850*	6900	5750*	3800	4350*	2550	—	—	2300*	1900
9'10"	lb	18,150	14,800	12,500	8100	9400	5450	—	—	5000	4150

**312E L ● 600 mm (24") Track Shoes ● Reach Boom ● No Bucket ● Blade Down**

Stick		3 m 9'10"		4.5 m 15'0"		6 m 20'0"		7.5 m 25'0"		At Max. Reach	
		Front	Side	Front	Side	Front	Side	Front	Side	Front	Side
2500 mm	kg	6900	6900	6000	3950	4500	2650	—	—	2600	2200
8'2"	lb	15,950	15,450	13,000	8500	9750	5700	—	—	5650	4800
2800 mm	kg	7500*	7200	5900*	3950	4400*	2650	—	—	2500*	2050
9'2"	lb	17,350	15,450	12,700	8450	9550	5650	—	—	5450	4500
3000 mm	kg	7850*	7200	5750*	3950	4350*	2650	—	—	2300*	2000
9'10"	lb	18,150	15,450	12,500	8450	9400	5650	—	—	5000	4350

**312E L ● 700 mm (28") Track Shoes ● Reach Boom ● No Bucket ● Blade Down**

Stick		3 m 9'10"		4.5 m 15'0"		6 m 20'0"		7.5 m 25'0"		At Max. Reach	
		Front	Side	Front	Side	Front	Side	Front	Side	Front	Side
2500 mm	kg	6900*	6900*	6000*	4100	4500*	2750	—	—	2600*	2300
8'2"	lb	15,950	15,950	13,000	8850	9750	5950	—	—	5650	5000
2800 mm	kg	7500*	7500*	5900*	4100	4400*	2750	—	—	2500*	2150
9'2"	lb	16,500	16,500	12,700	8800	9550	5900	—	—	5450	4700
3000 mm	kg	7850*	7550	5750*	4100	4350*	2750	—	—	2300*	2050
9'10"	lb	18,150	16,150	12,500	8800	9400	5900	—	—	5000	4500

**China, Asia Pacific**

**313D2 ● 500 mm (20") Track Shoes ● HD Boom ● No Bucket**

Stick		3 m 9'10"		4.5 m 15'0"		6 m 20'0"		7.5 m 25'0"		At Max. Reach	
		Front	Side	Front	Side	Front	Side	Front	Side	Front	Side
2500 mm	kg	6850*	5600	4550	3100	3000	2100	—	—	2450	1700
8'2"	lb	15,850*	12,050	9750	6700	6400	4500	—	—	5350	3750

**Asia Pacific**

**313D2 LGP ● 960 mm (38") Track Shoes ● HD Boom ● No Bucket**

Stick		3 m 9'10"		4.5 m 15'0"		6 m 20'0"		7.5 m 25'0"		At Max. Reach	
		Front	Side	Front	Side	Front	Side	Front	Side	Front	Side
2500 mm	kg	7500*	6450	6100	3600	4000	2450	—	—	2750*	2050
8'2"	lb	17,250*	13,850	13,100	7700	8600	5250	—	—	6100*	4550
3000 mm	kg	8050*	6500	6000*	3600	4000	2450	—	—	2500*	1900
9'10"	lb	18,500*	13,950	12,950*	7800	8650	5300	—	—	5450*	4200

\*Load limited by hydraulic capacity rather than tipping.

**North America, Europe, Turkey**

**313F L GC ● 500 mm (20") Track Shoes ● HD Counterweight ● Reach Boom ● No Bucket**

Stick		3 m 9'10"		4.5 m 15'0"		6 m 20'0"		7.5 m 25'0"		At Max. Reach	
		Front	Side	Front	Side	Front	Side	Front	Side	Front	Side
2500 mm	kg	6900*	5800	5300	3250	3450	2200			2600*	1800
8'2"	lb	<b>15,900*</b>	<b>12,500</b>	<b>11,350</b>	<b>6950</b>	<b>7400</b>	<b>4700</b>	—	—	<b>5650*</b>	<b>3950</b>
3000 mm	kg	7850*	5800	5300	3250	3400	2150			2300*	1600
9'10"	lb	<b>18,150*</b>	<b>12,450</b>	<b>11,300</b>	<b>6950</b>	<b>7350</b>	<b>4650</b>	—	—	<b>5000*</b>	<b>3550</b>

**313F L GC ● 700 mm (28") Track Shoes ● HD Counterweight ● Reach Boom ● No Bucket**

Stick		3 m 9'10"		4.5 m 15'0"		6 m 20'0"		7.5 m 25'0"		At Max. Reach	
		Front	Side	Front	Side	Front	Side	Front	Side	Front	Side
2500 mm	kg	6900*	6050	5500	3350	3600	2300			2600*	1900
8'2"	lb	<b>15,900*</b>	<b>12,950</b>	<b>11,800</b>	<b>7250</b>	<b>7700</b>	<b>4900</b>	—	—	<b>5650*</b>	<b>4100</b>
3000 mm	kg	7850*	6000	5450	3350	3550	2250			2300*	1700
9'10"	lb	<b>18,150*</b>	<b>12,900</b>	<b>11,750</b>	<b>7200</b>	<b>7650</b>	<b>4850</b>	—	—	<b>5000*</b>	<b>3700</b>

**313F L GC ● 500 mm (20") Track Shoes ● HD Counterweight ● Reach Boom ● No Bucket ● Blade Down**

Stick		3 m 9'10"		4.5 m 15'0"		6 m 20'0"		7.5 m 25'0"		At Max. Reach	
		Front	Side	Front	Side	Front	Side	Front	Side	Front	Side
2500 mm	kg	6900*	6800	6000	3750	4500	2550			2600*	2100
8'2"	lb	<b>15,900*</b>	<b>14,600</b>	<b>13,000*</b>	<b>8050</b>	<b>9700*</b>	<b>5400</b>	—	—	<b>5650*</b>	<b>4550</b>
3000 mm	kg	7850*	6800	5750*	3750	4300*	2500			2300*	1850
9'10"	lb	<b>18,150*</b>	<b>14,600</b>	<b>12,450*</b>	<b>8000</b>	<b>9350*</b>	<b>5350</b>	—	—	<b>5000*</b>	<b>4100</b>

**313F L GC ● 700 mm (28") Track Shoes ● HD Counterweight ● Reach Boom ● No Bucket ● Blade Down**

Stick		3 m 9'10"		4.5 m 15'0"		6 m 20'0"		7.5 m 25'0"		At Max. Reach	
		Front	Side	Front	Side	Front	Side	Front	Side	Front	Side
2500 mm	kg	6900*	6900*	6000*	4050	4500*	2750			2600*	2250
8'2"	lb	<b>15,900*</b>	<b>15,900*</b>	<b>13,000*</b>	<b>8700</b>	<b>9700*</b>	<b>5850</b>	—	—	<b>5650*</b>	<b>4950</b>
3000 mm	kg	7850*	7450	5750*	4050	4300*	2700			2300*	2050
9'10"	lb	<b>18,150*</b>	<b>15,950</b>	<b>12,450*</b>	<b>8650</b>	<b>9350*</b>	<b>5800</b>	—	—	<b>5000*</b>	<b>4450</b>

**Australia, New Zealand and Polynesia, Japan**

**314E CR ● 500 mm (20") Track Shoes ● Reach Boom ● No Bucket**

Stick		3 m 9'10"		4.5 m 15'0"		6 m 20'0"		7.5 m 25'0"		At Max. Reach	
		Front	Side	Front	Side	Front	Side	Front	Side	Front	Side
2500 mm	kg	6550*	4650	3950	2600	2600	1750			2100	1400
8'2"	lb	<b>15,100*</b>	<b>10,000</b>	<b>8500</b>	<b>5600</b>	<b>5600</b>	<b>3750</b>	—	—	<b>4600</b>	<b>3100</b>
3000 mm	kg	7350*	4650	3950	2600	2600	1700			1900	1250
9'10"	lb	<b>16,400</b>	<b>9950</b>	<b>8450</b>	<b>5550</b>	<b>5500</b>	<b>3700</b>	—	—	<b>4150</b>	<b>2750</b>

\*Load limited by hydraulic capacity rather than tipping.

**North America, Europe, Australia, New Zealand and Polynesia, Japan**

**314E LCR ● 500 mm (20") Track Shoes ● Reach Boom ● No Bucket**

Stick		3 m 9'10"		4.5 m 15'0"		6 m 20'0"		7.5 m 25'0"		At Max. Reach	
		Front	Side	Front	Side	Front	Side	Front	Side	Front	Side
2500 mm	kg	6550*	5600	5300	3150	3450	2100			2600*	1750
8'2"	lb	15,100*	12,000	11,400	6700	7450	4550	—	—	5700*	3750
3000 mm	kg	7350*	5600	5300	3100	3450	2100			2300*	1550
9'10"	lb	16,950*	11,950	11,350	6650	7400	4450	—	—	5050*	3400

**314E LCR ● 500 mm (20") Track Shoes ● Reach Boom ● No Bucket ● Blade Down**

Stick		3 m 9'10"		4.5 m 15'0"		6 m 20'0"		7.5 m 25'0"		At Max. Reach	
		Front	Side	Front	Side	Front	Side	Front	Side	Front	Side
2500 mm	kg	6550*	6550	5700*	3650	4150*	2450			2600*	2000
8'2"	lb	15,100*	14,250	12,300*	7850	8950*	5300	—	—	5700*	4400
3000 mm	kg	7350*	6600	5600*	3650	4100*	2450			2300*	1800
9'10"	lb	16,950*	14,200	12,100*	7800	8850*	5200	—	—	5050*	3950

**316E L ● 500 mm (20") Track Shoes ● Reach Boom ● No Bucket**

Stick		3 m 9'10"		4.5 m 15'0"		6 m 20'0"		7.5 m 25'0"		At Max. Reach	
		Front	Side	Front	Side	Front	Side	Front	Side	Front	Side
2250 mm	kg	5600*	5600*	7300	4250	4750	2900			3800	2350
7'5"	lb	12,950*	12,950*	15,700	9100	10,200	6200	—	—	8350	5100
2600 mm	kg	6250*	6250*	7300	4250	4750	2900			3400*	2200
8'6"	lb	14,400*	14,400*	15,700	9100	10,200	6200	—	—	7450*	4750
2900 mm	kg	7050*	7050*	7300	4200	4750	2850	3450	2100	3200*	2050
9'6"	lb	16,150*	16,150*	15,650	9050	10,150	6100	7450	4500	7050*	4500
3100 mm	kg	6650*	6650*	7300	4200	4700	2850	3400	2100	2800*	1950
10'2"	lb	15,300*	15,300*	15,650	9050	10,150	6100	7350	4450	6150*	4250

**316E L ● 600 mm (24") Track Shoes ● Reach Boom ● No Bucket**

Stick		3 m 9'10"		4.5 m 15'0"		6 m 20'0"		7.5 m 25'0"		At Max. Reach	
		Front	Side	Front	Side	Front	Side	Front	Side	Front	Side
2250 mm	kg	5600*	5600*	7400	4300	4800	2900			3850	2350
7'5"	lb	12,950*	12,950*	15,850	9200	10,350	6250	—	—	8450	5150
2600 mm	kg	6250*	6250*	7400	4300	4800	2900			3400*	2200
8'6"	lb	14,400*	14,400*	15,900	9250	10,350	6250	—	—	7450*	4850
2900 mm	kg	7050*	7050*	7400	4250	4800	2900	3500	2100	3200*	2100
9'6"	lb	16,150*	16,150*	15,850	9150	10,300	6200	7700	4600	7050*	4600
3100 mm	kg	6650*	6650*	7400	4250	4800	2900	3450	2100	2800*	1950
10'2"	lb	15,300*	15,300*	15,850	9200	10,250	6200	7450	4500	6150*	4300

**316E L ● 700 mm (28") Track Shoes ● Reach Boom ● No Bucket**

Stick		3 m 9'10"		4.5 m 15'0"		6 m 20'0"		7.5 m 25'0"		At Max. Reach	
		Front	Side	Front	Side	Front	Side	Front	Side	Front	Side
2250 mm	kg	5600*	5600*	7500	4350	4900	2950			3900	2400
7'5"	lb	12,950*	12,950*	16,100	9350	10,500	6350	—	—	8550	5250
2600 mm	kg	6250*	6250*	7500	4350	4900	2950			3400*	2250
8'6"	lb	14,400*	14,400*	16,100	9350	10,500	6350	—	—	7450*	4900
2900 mm	kg	7050*	7050*	7500	4300	4850	2950	3500	2150	3200*	2100
9'6"	lb	16,150*	16,150*	16,050	9300	10,450	6300	7700	4750	7050*	4650
3100 mm	kg	6650*	6650*	7500	4350	4850	2900	3500	2150	2800*	2000
10'2"	lb	15,300*	15,300*	16,100	9300	10,400	6250	7500	4600	6150*	4400

\*Load limited by hydraulic capacity rather than tipping.

**Middle East, Africa, CIS, South America, Asia Pacific**

**318D2 L ● 600 mm (24") Track Shoes ● Reach Boom ● No Bucket**

Stick		3 m 9'10"		4.5 m 15'0"		6 m 20'0"		7.5 m 25'0"		At Max. Reach	
		Front	Side	Front	Side	Front	Side	Front	Side	Front	Side
2600 mm	kg	6250*	6250*	7450	4400	4850	3000			3400*	2250
8'6"	lb	<b>14,400*</b>	<b>14,400*</b>	<b>16,000</b>	<b>9500</b>	<b>10,400</b>	<b>6450</b>	—	—	<b>7450*</b>	<b>5000</b>
2900 mm	kg	7050*	7050*	7450	4400	4800	2950	3500	2200	3200*	2150
9'6"	lb	<b>16,150*</b>	<b>16,150*</b>	<b>15,950</b>	<b>9450</b>	<b>10,350</b>	<b>6400</b>	<b>7700</b>	<b>4750</b>	<b>7050*</b>	<b>4700</b>

**China**

**318D2 L ● 600 mm (24") Track Shoes ● HD Boom ● No Bucket**

Stick		3 m 9'10"		4.5 m 15'0"		6 m 20'0"		7.5 m 25'0"		At Max. Reach	
		Front	Side	Front	Side	Front	Side	Front	Side	Front	Side
2600 mm	kg	6250*	6250*	7350	4250	4750	2900	—	—	3350*	2150
8'6"	lb	<b>14,350*</b>	<b>14,350*</b>	<b>15,700</b>	<b>9150</b>	<b>10,200</b>	<b>6200</b>	—	—	<b>7400*</b>	<b>4750</b>
2900 mm	kg	7050*	7050*	7400	4350	4800	2950	3450	2150	3200*	2100
9'6"	lb	<b>16,150*</b>	<b>16,150*</b>	<b>15,850</b>	<b>9300</b>	<b>10,300</b>	<b>6300</b>	<b>7450</b>	<b>4700</b>	<b>7050*</b>	<b>4650</b>

7

**North America, Australia, New Zealand and Polynesia, Asia Pacific**

**318E L ● 500 mm (20") Track Shoes ● Reach Boom ● No Bucket**

Stick		3 m 9'10"		4.5 m 15'0"		6 m 20'0"		7.5 m 25'0"		At Max. Reach	
		Front	Side	Front	Side	Front	Side	Front	Side	Front	Side
2250 mm	kg	6050*	6050*	7950*	4650	5400	3200	—	—	4050*	2550
7'5"	lb	<b>14,000*</b>	<b>14,000*</b>	<b>17,200*</b>	<b>10,050</b>	<b>11,650</b>	<b>6850</b>	—	—	<b>8850*</b>	<b>5650</b>
2600 mm	kg	6750*	6750*	7850*	4700	5400	3200	—	—	3350*	2400
8'6"	lb	<b>15,550*</b>	<b>15,550*</b>	<b>16,950*</b>	<b>10,050</b>	<b>11,650</b>	<b>6850</b>	—	—	<b>7400*</b>	<b>5300</b>
2900 mm	kg	7600*	7600*	7700*	4650	5400	3150	3700*	2350*	3200*	2300
9'6"	lb	<b>17,450*</b>	<b>17,450*</b>	<b>16,600*</b>	<b>10,050</b>	<b>11,600</b>	<b>6800</b>	<b>7900*</b>	<b>5150*</b>	<b>7000*</b>	<b>5050</b>
3100 mm	kg	7200*	7200*	7550*	4650	5400	3150	3900	2300	2800*	2150
10'2"	lb	<b>16,550*</b>	<b>16,550*</b>	<b>16,350*</b>	<b>10,050</b>	<b>11,600</b>	<b>6750</b>	<b>8350</b>	<b>4950</b>	<b>6100*</b>	<b>4750</b>

**318E L ● 600 mm (24") Track Shoes ● Reach Boom ● No Bucket**

Stick		3 m 9'10"		4.5 m 15'0"		6 m 20'0"		7.5 m 25'0"		At Max. Reach	
		Front	Side	Front	Side	Front	Side	Front	Side	Front	Side
2250 mm	kg	6050*	6050*	7950*	4700	5500	3200	—	—	4050*	2600
7'5"	lb	<b>14,000*</b>	<b>14,000*</b>	<b>17,200*</b>	<b>10,150</b>	<b>11,800</b>	<b>6900</b>	—	—	<b>8850*</b>	<b>5700</b>
2600 mm	kg	6750*	6750*	7850*	4750	5500	3200	—	—	3350*	2450
8'6"	lb	<b>15,550*</b>	<b>15,550*</b>	<b>16,950*</b>	<b>10,200</b>	<b>11,800</b>	<b>6900</b>	—	—	<b>7400*</b>	<b>5350</b>
2900 mm	kg	7600*	7600*	7700*	4700	5450	3200	3700*	2350*	3200*	2300
9'6"	lb	<b>17,450*</b>	<b>17,450*</b>	<b>16,600*</b>	<b>10,150</b>	<b>11,750</b>	<b>6850</b>	<b>7900*</b>	<b>5150*</b>	<b>7000*</b>	<b>5100</b>
3100 mm	kg	7200*	7200*	7550*	4700	5450	3200	3950	2350	2800*	2200
10'2"	lb	<b>16,550*</b>	<b>16,550*</b>	<b>16,350*</b>	<b>10,150</b>	<b>11,700</b>	<b>6850</b>	<b>8450</b>	<b>5000</b>	<b>6100*</b>	<b>4800</b>

**318E L ● 700 mm (28") Track Shoes ● Reach Boom ● No Bucket**

Stick		3 m 9'10"		4.5 m 15'0"		6 m 20'0"		7.5 m 25'0"		At Max. Reach	
		Front	Side	Front	Side	Front	Side	Front	Side	Front	Side
2250 mm	kg	6050*	6050*	7950*	4800	5550	3250	—	—	4050*	2650
7'5"	lb	<b>14,000*</b>	<b>14,000*</b>	<b>17,200*</b>	<b>10,300</b>	<b>11,950</b>	<b>7000</b>	—	—	<b>8850*</b>	<b>5800</b>
2600 mm	kg	6750*	6750*	7850*	4800	5550	3250	—	—	3350*	2450
8'6"	lb	<b>15,550*</b>	<b>15,550*</b>	<b>16,950*</b>	<b>10,300</b>	<b>11,950</b>	<b>7000</b>	—	—	<b>7400*</b>	<b>5400</b>
2900 mm	kg	7600*	7600*	7700*	4800	5550	3250	3700*	2400	3200*	2350
9'6"	lb	<b>17,450*</b>	<b>17,450*</b>	<b>16,600*</b>	<b>10,300</b>	<b>11,900</b>	<b>6950</b>	<b>7900*</b>	<b>5250</b>	<b>7000*</b>	<b>5150</b>
3100 mm	kg	7200*	7200*	7550*	4800	5550	3250	4000	2350	2800*	2200
10'2"	lb	<b>16,550*</b>	<b>16,550*</b>	<b>16,350*</b>	<b>10,250</b>	<b>11,850</b>	<b>6950</b>	<b>8600</b>	<b>5050</b>	<b>6100*</b>	<b>4850</b>

\*Load limited by hydraulic capacity rather than tipping.



**M313D†/M315D2 ● Rear Dozer Up**

Stick		3 m 9'10"		4.5 m 15'0"		6 m 20'0"		7.5 m 25'0"		At Max. Reach	
		Front	Side	Front	Side	Front	Side	Front	Side	Front	Side
2000 mm	kg	—	—	4900	2900	3200	1900	—	—	2300*	1400
6'7"	lb	—	—	10,805	6395	7056	4190	—	—	5071*	3087
2300 mm	kg	4300*	4300*	4900	2900	3200	1900	—	—	2100*	1300
7'7"	lb	9482*	9482*	10,805	6395	7056	4190	—	—	4631*	2867
2600 mm	kg	4600*	4600*	4800	2900	3100	1900	2300	1400	1800*	1200
8'6"	lb	10,143*	10,143*	10,573	6395	6836	4190	5072	3087	3969*	2646

**M313D†/M315D2 ● Rear Dozer Down**

Stick		3 m 9'10"		4.5 m 15'0"		6 m 20'0"		7.5 m 25'0"		At Max. Reach	
		Front	Side	Front	Side	Front	Side	Front	Side	Front	Side
2000 mm	kg	—	—	6700*	3400	4800*	2200	—	—	2300*	1700
6'7"	lb	—	—	14,774*	7497	10,584*	4851	—	—	5071*	3749
2300 mm	kg	4300*	4300*	6700*	3400	4800*	2200	—	—	2100*	1600
7'7"	lb	9482*	9482*	14,774*	7497	10,584*	4851	—	—	4631*	3528
2600 mm	kg	4600*	4600*	6700*	3400	4800*	2200	2600*	1600	1800*	1500
8'6"	lb	10,143*	10,143*	14,774*	7497	10,584*	4851	5733*	3528	3969*	3308

**M313D†/M315D2 ● Rear Stabilizer Down**

Stick		3 m 9'10"		4.5 m 15'0"		6 m 20'0"		7.5 m 25'0"		At Max. Reach	
		Front	Side	Front	Side	Front	Side	Front	Side	Front	Side
2000 mm	kg	—	—	6700*	4200	4500	2800	—	—	2300*	2000
6'7"	lb	—	—	14,774*	9261	9923	6174	—	—	5071*	4410
2300 mm	kg	4300*	4300*	6700*	4200	4500	2800	—	—	2100*	1900
7'7"	lb	9482*	9482*	14,774*	9261	9923	6174	—	—	4631*	4190
2600 mm	kg	4600*	4600*	6700*	4200	4500	2800	2600*	2000	1800*	1800*
8'6"	lb	10,143*	10,143*	14,774*	9261	9923	6174	5733*	4410	3969*	3969*

**M313D†/M315D2 ● 4-Point Stabilizers Down**

Stick		3 m 9'10"		4.5 m 15'0"		6 m 20'0"		7.5 m 25'0"		At Max. Reach	
		Front	Side	Front	Side	Front	Side	Front	Side	Front	Side
2000 mm	kg	—	—	6700*	6600	4800*	4200	—	—	2300*	2300*
6'7"	lb	—	—	14,774*	14,553	10,584*	9261	—	—	5071*	5071*
2300 mm	kg	4300*	4300*	6700*	6600	4800*	4200	—	—	2100*	2100*
7'7"	lb	9482*	9482*	14,774*	14,553	10,584*	9261	—	—	4631*	4631*
2600 mm	kg	4600*	4600*	6700*	6600	4800*	4200	2600*	2600*	1800*	1800*
8'6"	lb	10,143*	10,143*	14,774*	14,553	10,584*	9261	5733*	5733*	3969*	3969*

**M313D†/M315D2 ● Dozer and Stabilizer Down**

Stick		3 m 9'10"		4.5 m 15'0"		6 m 20'0"		7.5 m 25'0"		At Max. Reach	
		Front	Side	Front	Side	Front	Side	Front	Side	Front	Side
2000 mm	kg	—	—	6700*	5300	4800*	3400	—	—	2300*	2300*
6'7"	lb	—	—	14,774*	11,687	10,584*	7497	—	—	5071*	5071*
2300 mm	kg	4300*	4300*	6700*	5300	4800*	3400	—	—	2100*	2100*
7'7"	lb	9482*	9482*	14,774*	11,687	10,584*	7497	—	—	4631*	4631*
2600 mm	kg	4600*	4600*	6700*	5300	4800*	3400	2600*	2500	1800*	1800*
8'6"	lb	10,143*	10,143*	14,774*	11,687	10,584*	7497	5733*	5513	3969*	3969*

\*Load limited by hydraulic capacity rather than tipping.

†This product has been discontinued.

**M313D†/M315D2 ● Rear Dozer Up**

Stick		3 m 9'10"		4.5 m 15'0"		6 m 20'0"		7.5 m 25'0"		At Max. Reach	
		Front	Side	Front	Side	Front	Side	Front	Side	Front	Side
2000 mm	kg	10 200	5900	5300	3300	3300	2000	—	—	2200	1300
6'7"	lb	22,491	13,010	11,687	7277	7277	4410	—	—	4851	2867
2300 mm	kg	10 000*	6000	5300	3300	3300	2100	2300	1300	2100	1200
7'7"	lb	22,050*	13,230	11,687	7277	7277	4631	5072	2867	4631	2646
2600 mm	kg	9800*	6000	5200*	3300	3400	2100	2300	1300	1900*	1100
8'6"	lb	21,609*	13,230	11,466*	7277	7497	4631	5072	2867	4189*	2426

**M313D†/M315D2 ● Rear Dozer Down**

Stick		3 m 9'10"		4.5 m 15'0"		6 m 20'0"		7.5 m 25'0"		At Max. Reach	
		Front	Side	Front	Side	Front	Side	Front	Side	Front	Side
2000 mm	kg	10 200*	7000	6600*	3800	4800*	2400	—	—	2500*	1500
6'7"	lb	22,491*	15,435	14,553*	8379	10,584*	5292	—	—	5513*	3308
2300 mm	kg	10 000*	7100	6600*	3800	4800*	2400	3000*	1600	2200*	1400
7'7"	lb	22,050*	15,656	14,553*	8379	10,584*	5292	6615*	3528	4851*	3087
2600 mm	kg	9800*	7100*	6500*	3800	4700*	2400	3500*	1600	1900*	1300
8'6"	lb	21,609*	15,656*	14,333*	8379	10,364*	5292	7718*	3528	4189*	2867

**M313D†/M315D2 ● Rear Stabilizer Down**

Stick		3 m 9'10"		4.5 m 15'0"		6 m 20'0"		7.5 m 25'0"		At Max. Reach	
		Front	Side	Front	Side	Front	Side	Front	Side	Front	Side
2000 mm	kg	10 200*	8900*	6600*	4700	4700	2900	—	—	2500*	1900*
6'7"	lb	22,491*	19,625*	14,553*	10,364	10,364	6395	—	—	5513*	4189*
2300 mm	kg	10 000*	8900	6600*	4700	4600*	3300	3000*	2000	2200*	1800
7'7"	lb	22,050*	19,625	14,553*	10,364	10,143*	7277	6615*	4410	4851*	3969
2600 mm	kg	9800*	8800	6500*	4700	4600*	3000	3200	2000	1900*	1700
8'6"	lb	21,609*	19,404	14,333*	10,364	10,143*	6615	7056	4410	4189*	3749

**M313D†/M315D2 ● 4-Point Stabilizers Down**

Stick		3 m 9'10"		4.5 m 15'0"		6 m 20'0"		7.5 m 25'0"		At Max. Reach	
		Front	Side	Front	Side	Front	Side	Front	Side	Front	Side
2000 mm	kg	10 200*	10 200*	6600*	6600*	4800*	4300	—	—	2500*	2500*
6'7"	lb	22,491*	22,491*	14,553*	14,553*	10,584*	9482	—	—	5513*	5513*
2300 mm	kg	10 000*	10 000*	6600*	6600*	4800*	4400	3000*	3000	2200*	2200*
7'7"	lb	22,050*	22,050*	14,553*	14,553*	10,584*	9702	6615*	6615	4851*	4851*
2600 mm	kg	9800*	9800*	6500*	6500*	4700*	4400	3500*	3000	1900*	1900*
8'6"	lb	21,609*	21,609*	14,333*	14,333*	10,364*	9702	7718*	6615	4189*	4189*

**M313D†/M315D2 ● Dozer and Stabilizer Down**

Stick		3 m 9'10"		4.5 m 15'0"		6 m 20'0"		7.5 m 25'0"		At Max. Reach	
		Front	Side	Front	Side	Front	Side	Front	Side	Front	Side
2000 mm	kg	10 200*	10 200*	6600*	5700*	4800*	3600	—	—	2500*	2400
6'7"	lb	22,491*	22,491	14,553*	12,569*	10,584*	7938	—	—	5513*	5292
2300 mm	kg	10 000*	10 000*	6600*	5700	4800*	3600	3000*	2500	2200*	2200*
7'7"	lb	22,050*	22,050*	14,553*	12,569	10,584*	7938	6615*	5513	4851*	4851*
2600 mm	kg	9800*	9800*	6500*	5600	4700*	3600	3500*	2500	1900*	1900*
8'6"	lb	21,609*	21,609*	14,333*	12,348	10,364*	7938	7718*	5513	4189*	4189*

\*Load limited by hydraulic capacity rather than tipping.

†This product has been discontinued.

**M315D†/M317D2 ● Rear Dozer Up**

Stick		3 m 9'10"		4.5 m 15'0"		6 m 20'0"		7.5 m 25'0"		At Max. Reach	
		Front	Side	Front	Side	Front	Side	Front	Side	Front	Side
2100 mm	kg	—	—	5700	3300	3700	2200	—	—	2500	1500
6'11"	lb	—	—	12,569	7277	8159	4851	—	—	5513	3308
2400 mm	kg	4000*	4000*	5600	3200	3700	2200	2600	1600	2400	1400
7'10"	lb	8820*	8820*	12,348	7056	8159	4851	5733	3528	5292	3087
2600 mm	kg	4200*	4200*	5700	3300	3700	2200	2600	1600	2300	1400
8'6"	lb	9261*	9261*	12,569	7277	8159	4851	5733	3528	5072	3087

**M315D†/M317D2 ● Rear Dozer Down**

Stick		3 m 9'10"		4.5 m 15'0"		6 m 20'0"		7.5 m 25'0"		At Max. Reach	
		Front	Side	Front	Side	Front	Side	Front	Side	Front	Side
2100 mm	kg	—	—	7900*	3800	5700*	2500	—	—	2900*	1800
6'11"	lb	—	—	17,419*	8379	12,569*	5513	—	—	6395*	3969
2400 mm	kg	4000*	4000*	7900*	3800	5700*	2500	4000	1800	2600*	1700
7'10"	lb	8820*	8820*	17,419*	8379	12,569*	5513	8820	3969	5733*	3749
2600 mm	kg	4200*	4200*	7900*	3800	5700*	2500	4000	1800	2400*	1600
8'6"	lb	9261*	9261*	17,419*	8379	12,569*	5513	8820	3969	5292*	3528

**M315D†/M317D2 ● Rear Stabilizer Down**

Stick		3 m 9'10"		4.5 m 15'0"		6 m 20'0"		7.5 m 25'0"		At Max. Reach	
		Front	Side	Front	Side	Front	Side	Front	Side	Front	Side
2100 mm	kg	—	—	7900*	4800	5100	3100	—	—	2900*	2200
6'11"	lb	—	—	17,419*	10,584	11,246	6836	—	—	6395*	4851
2400 mm	kg	4000*	4000*	7900*	4800	5100	3100	3600	2300	2600*	2100
7'10"	lb	8820*	8820*	17,419*	10,584	11,246	6836	7938	5072	5733*	4631
2600 mm	kg	4200*	4200*	7900*	4800	5100	3100	3600	2300	2400*	2000
8'6"	lb	9261*	9261*	17,419*	10,584	11,246	6836	7938	5072	5292*	4410

**M315D†/M317D2 ● 4-Point Stabilizers Down**

Stick		3 m 9'10"		4.5 m 15'0"		6 m 20'0"		7.5 m 25'0"		At Max. Reach	
		Front	Side	Front	Side	Front	Side	Front	Side	Front	Side
2100 mm	kg	—	—	7900*	7300	5700*	4700	—	—	2900*	2900*
6'11"	lb	—	—	17,419*	16,097	12,569*	10,364	—	—	6395*	6395*
2400 mm	kg	4000*	4000*	7900*	7300	5700*	4600	4200*	3300	2600*	2600*
7'10"	lb	8820*	8820*	17,419*	16,097	12,569*	10,143	9261*	7277	5733*	5733*
2600 mm	kg	4200*	4200*	7900*	7300	5700*	4600	4400*	3300	2400*	2400*
8'6"	lb	9261*	9261*	17,419*	16,097	12,569*	10,143	9702*	7277	5292*	5292*

**M315D†/M317D2 ● Dozer and Stabilizer Down**

Stick		3 m 9'10"		4.5 m 15'0"		6 m 20'0"		7.5 m 25'0"		At Max. Reach	
		Front	Side	Front	Side	Front	Side	Front	Side	Front	Side
2100 mm	kg	—	—	7900*	5900	5700*	3800	—	—	2900*	2700
6'11"	lb	—	—	17,419*	13,010	12,569*	8379	—	—	6395*	5954
2400 mm	kg	4000*	4000*	7900*	5900	5700*	3800	4200*	2800	2600*	2500
7'10"	lb	8820*	8820*	17,419*	13,010	12,569*	8379	9261*	6174	5733*	5513
2600 mm	kg	4200*	4200*	7900*	5900	5700*	3800	4400*	2800	2400*	2400*
8'6"	lb	9261*	9261*	17,419*	13,010	12,569*	8379	9702*	6174	5292*	5292*

\*Load limited by hydraulic capacity rather than tipping.

†This product has been discontinued.

**M315D†/M317D2 ● Rear Dozer Up**

Stick		3 m 9'10"		4.5 m 15'0"		6 m 20'0"		7.5 m 25'0"		At Max. Reach	
		Front	Side	Front	Side	Front	Side	Front	Side	Front	Side
2100 mm	kg	11 800*	6600	6300	3800	3900	2400	2600	1500	2400	1400
6'11"	lb	<b>26,019*</b>	<b>14,553</b>	<b>13,892</b>	<b>8379</b>	<b>8600</b>	<b>5292</b>	<b>5733</b>	<b>3308</b>	<b>5292</b>	<b>3087</b>
2400 mm	kg	11 600*	6900	6200	3800	4000	2400	2600	1500	2300	1300
7'10"	lb	<b>25,578*</b>	<b>15,215</b>	<b>13,671</b>	<b>8379</b>	<b>8820</b>	<b>5292</b>	<b>5733</b>	<b>3308</b>	<b>5072</b>	<b>2867</b>
2600 mm	kg	11 200*	6900	6200	3800	4000	2500	2700	1600	2200	1300
8'6"	lb	<b>24,696*</b>	<b>15,215</b>	<b>13,671</b>	<b>8379</b>	<b>8820</b>	<b>5513</b>	<b>5954</b>	<b>3528</b>	<b>4851</b>	<b>2867</b>

**M315D†/M317D2 ● Rear Dozer Down**

Stick		3 m 9'10"		4.5 m 15'0"		6 m 20'0"		7.5 m 25'0"		At Max. Reach	
		Front	Side	Front	Side	Front	Side	Front	Side	Front	Side
2100 mm	kg	11 800*	7900	7900*	4400	5700*	2700	4000*	1800	2900*	1700
6'11"	lb	<b>26,019*</b>	<b>17,420</b>	<b>17,420*</b>	<b>9702</b>	<b>12,569*</b>	<b>5954</b>	<b>8820*</b>	<b>3969</b>	<b>6395*</b>	<b>3749</b>
2400 mm	kg	11 600*	8100	7800*	4400	5600*	2800	4100	1800	2500*	1500
7'10"	lb	<b>25,578*</b>	<b>17,861</b>	<b>17,199*</b>	<b>9702</b>	<b>12,348*</b>	<b>6174</b>	<b>9041</b>	<b>3969</b>	<b>5513*</b>	<b>3308</b>
2600 mm	kg	11 200*	8200	7800*	4400	5600*	2800	4100	1800	2300*	1500
8'6"	lb	<b>24,696*</b>	<b>18,081</b>	<b>17,199*</b>	<b>9702</b>	<b>12,348*</b>	<b>6174</b>	<b>9041</b>	<b>3969</b>	<b>5072*</b>	<b>3308</b>

7

**M315D†/M317D2 ● Rear Stabilizer Down**

Stick		3 m 9'10"		4.5 m 15'0"		6 m 20'0"		7.5 m 25'0"		At Max. Reach	
		Front	Side	Front	Side	Front	Side	Front	Side	Front	Side
2100 mm	kg	11 800*	10 200	7900*	5400	5400	3400	3600	2200	2900*	2100
6'11"	lb	<b>26,019*</b>	<b>22,491</b>	<b>17,420*</b>	<b>11,907</b>	<b>11,907</b>	<b>7497</b>	<b>7938</b>	<b>4851</b>	<b>6395*</b>	<b>4631</b>
2400 mm	kg	11 600*	10 100*	7800*	5400	5300	3400	3600	2300	2500*	1900
7'10"	lb	<b>25,578*</b>	<b>22,271*</b>	<b>17,199*</b>	<b>11,907</b>	<b>11,687</b>	<b>7497</b>	<b>7938</b>	<b>5072</b>	<b>5513*</b>	<b>4190</b>
2600 mm	kg	11 200*	10 100	7800*	5400	5300	3500	3700	2300	2300*	1900
8'6"	lb	<b>24,696*</b>	<b>22,271</b>	<b>17,199*</b>	<b>11,907</b>	<b>11,687</b>	<b>7718</b>	<b>8159</b>	<b>5072</b>	<b>5072*</b>	<b>4190</b>

**M315D†/M317D2 ● 4-Point Stabilizers Down**

Stick		3 m 9'10"		4.5 m 15'0"		6 m 20'0"		7.5 m 25'0"		At Max. Reach	
		Front	Side	Front	Side	Front	Side	Front	Side	Front	Side
2100 mm	kg	11 800*	11 800*	7900*	7600	5700*	4900	4000*	3300	2900*	2900*
6'11"	lb	<b>26,019*</b>	<b>26,019*</b>	<b>17,420*</b>	<b>16,758</b>	<b>12,569*</b>	<b>10,805</b>	<b>8820*</b>	<b>7277</b>	<b>6395*</b>	<b>6395*</b>
2400 mm	kg	11 600*	11 600*	7800*	7500*	5600*	5000	4300*	3300	2500*	2500*
7'10"	lb	<b>25,578*</b>	<b>25,578*</b>	<b>17,199*</b>	<b>16,538*</b>	<b>12,348*</b>	<b>11,025</b>	<b>9482*</b>	<b>7277</b>	<b>5513*</b>	<b>5513*</b>
2600 mm	kg	11 200*	11 200*	7800*	7500	5600*	5000	4300*	3400	2300*	2300*
8'6"	lb	<b>24,696*</b>	<b>24,696*</b>	<b>17,199*</b>	<b>16,538</b>	<b>12,348*</b>	<b>11,025</b>	<b>9482*</b>	<b>7497</b>	<b>5072*</b>	<b>5072*</b>

**M315D†/M317D2 ● Dozer and Stabilizer Down**

Stick		3 m 9'10"		4.5 m 15'0"		6 m 20'0"		7.5 m 25'0"		At Max. Reach	
		Front	Side	Front	Side	Front	Side	Front	Side	Front	Side
2100 mm	kg	11 800*	11 800*	7900*	6400	5700*	4100	4000*	2800	2900*	2500
6'11"	lb	<b>26,019*</b>	<b>26,019*</b>	<b>17,420*</b>	<b>14,112</b>	<b>12,569*</b>	<b>9041</b>	<b>8820*</b>	<b>6174</b>	<b>6395*</b>	<b>5513</b>
2400 mm	kg	11 600*	11 600*	7800*	6400*	5600*	4100	4300	2800	2500*	2400
7'10"	lb	<b>25,578*</b>	<b>25,578*</b>	<b>17,199*</b>	<b>14,112*</b>	<b>12,348*</b>	<b>9041</b>	<b>9482</b>	<b>6174</b>	<b>5513*</b>	<b>5292</b>
2600 mm	kg	11 200*	11 200*	7800*	6400	5600*	4200	4300*	2800	2300*	2300
8'6"	lb	<b>24,696*</b>	<b>24,696*</b>	<b>17,199*</b>	<b>14,112</b>	<b>12,348*</b>	<b>9261</b>	<b>9482*</b>	<b>6174</b>	<b>5072*</b>	<b>5072</b>

\*Load limited by hydraulic capacity rather than tipping.

†This product has been discontinued.

**M316D† ● Rear Dozer Up**

Stick		3 m 9'10"		4.5 m 15'0"		6 m 20'0"		7.5 m 25'0"		At Max. Reach	
		Front	Side	Front	Side	Front	Side	Front	Side	Front	Side
2100 mm	kg	—	—	6400	3700	4200	2500	—	—	2900*	1700
6'11"	lb	—	—	14,112	8159	9261	5513	—	—	6395*	3749
2400 mm	kg	4000*	4000*	6400	3600	4100	2400	3000	1800	2600*	1600
7'10"	lb	8820*	8820*	14,112	7938	9041	5292	6615	3969	5733*	3528
2600 mm	kg	4200*	4200*	6400	3700	4200	2400	3000	1800	2400*	1600
8'6"	lb	9261*	9261*	14,112	8159	9261	5292	6615	3969	5292*	3528

**M316D† ● Rear Dozer Down**

Stick		3 m 9'10"		4.5 m 15'0"		6 m 20'0"		7.5 m 25'0"		At Max. Reach	
		Rear	Side	Rear	Side	Rear	Side	Rear	Side	Rear	Side
2100 mm	kg	—	—	8800*	4200	6400*	2800	—	—	2900*	2000
6'11"	lb	—	—	19,404*	9261	14,112*	6174	—	—	6395*	4410
2400 mm	kg	4000*	4000*	8800*	4200	6300*	2800	4100*	2100	2600*	1900
7'10"	lb	8820*	8820*	19,404*	9261	13,892*	6174	9041*	4631	5733*	4190
2600 mm	kg	4200*	4200*	8800*	4200	6300*	2800	4700	2000	2400*	1800
8'6"	lb	9261*	9261*	19,404*	9261	13,892*	6174	10,364	4410	5292*	3969

**M316D† ● Rear Stabilizer Down**

Stick		3 m 9'10"		4.5 m 15'0"		6 m 20'0"		7.5 m 25'0"		At Max. Reach	
		Rear	Side	Rear	Side	Rear	Side	Rear	Side	Rear	Side
2100 mm	kg	—	—	8800*	5300	5800	3500	—	—	2900*	2400
6'11"	lb	—	—	19,404*	11,687	12,789	7718	—	—	6395*	5292
2400 mm	kg	4000*	4000*	8800*	5300	5800	3500	4100*	2500	2600*	2300
7'10"	lb	8820*	8820*	19,404*	11,687	12,789	7718	9041*	5513	5733*	5072
2600 mm	kg	4200*	4200*	8800*	5300	5800	3500	4100	2500	2400*	2200
8'6"	lb	9261*	9261*	19,404*	11,687	12,789	7718	9041	5513	5292*	4851

**M316D† ● 4-Point Stabilizers Down**

Stick		3 m 9'10"		4.5 m 15'0"		6 m 20'0"		7.5 m 25'0"		At Max. Reach	
		Front	Side	Front	Side	Front	Side	Front	Side	Front	Side
2100 mm	kg	—	—	8800*	8000	6400*	5100	—	—	2900*	2900*
6'11"	lb	—	—	19,404*	17,640	14,112*	11,246	—	—	6395*	6395*
2400 mm	kg	4000*	4000*	8800*	8000	6300*	5100	4100*	3700	2600*	2600*
7'10"	lb	8820*	8820*	19,404*	17,640	13,892*	11,246	9041*	8159	5733*	5733*
2600 mm	kg	4200*	4200*	8800*	8000	6300*	5100	4800*	3700	2400*	2400*
8'6"	lb	9261*	9261*	19,404*	17,640	13,892*	11,246	10,584*	8159	5292*	5292*

**M316D† ● Dozer and Stabilizer Down**

Stick		3 m 9'10"		4.5 m 15'0"		6 m 20'0"		7.5 m 25'0"		At Max. Reach	
		Front	Side	Front	Side	Front	Side	Front	Side	Front	Side
2100 mm	kg	—	—	8800*	6600	6400*	4300	—	—	2900*	2900*
6'11"	lb	—	—	19,404*	14,553	14,112*	9482	—	—	6395*	6395*
2400 mm	kg	4000*	4000*	8800*	6600	6300*	4300	4100*	3100	2600*	2600*
7'10"	lb	8820*	8820*	19,404*	14,553	13,892*	9482	9041*	6836	5733*	5733*
2600 mm	kg	4200*	4200*	8800*	6600	6300*	4300	4800*	3100	2400*	2400*
8'6"	lb	9261*	9261*	19,404*	14,553	13,892*	9482	10,584*	6836	5292*	5292*

\*Load limited by hydraulic capacity rather than tipping.

†This product has been discontinued.

**M316D† ● Rear Dozer Up**

Stick		3 m 9'10"		4.5 m 15'0"		6 m 20'0"		7.5 m 25'0"		At Max. Reach	
		Front	Side	Front	Side	Front	Side	Front	Side	Front	Side
2100 mm	kg	12 700*	7300	7000	4200	4400	2700	3000	1700	2800	1600
6'11"	lb	<b>28,004*</b>	<b>16,097</b>	<b>15,435</b>	<b>9261</b>	<b>9702</b>	<b>5954</b>	<b>6615</b>	<b>3749</b>	<b>6174</b>	<b>3528</b>
2400 mm	kg	12 500*	7600	6900	4200	4400	2700	3000	1800	2500*	1500
7'10"	lb	<b>27,563*</b>	<b>16,758</b>	<b>15,215</b>	<b>9261</b>	<b>9702</b>	<b>5954</b>	<b>6615</b>	<b>3969</b>	<b>5513*</b>	<b>3308</b>
2600 mm	kg	12 200*	7600	6900	4200	4500	2700	3000	1800	2300*	1400
8'6"	lb	<b>26,901*</b>	<b>16,758</b>	<b>15,215</b>	<b>9261</b>	<b>9923</b>	<b>5954</b>	<b>6615</b>	<b>3969</b>	<b>5072*</b>	<b>3087</b>

**M316D† ● Rear Dozer Down**

Stick		3 m 9'10"		4.5 m 15'0"		6 m 20'0"		7.5 m 25'0"		At Max. Reach	
		Front	Side	Front	Side	Front	Side	Front	Side	Front	Side
2100 mm	kg	12 700*	8700	8700*	4800	6300*	3100	4200*	2000	2900*	1900
6'11"	lb	<b>28,004*</b>	<b>19,184</b>	<b>19,184*</b>	<b>10,584</b>	<b>13,892*</b>	<b>6836</b>	<b>9261*</b>	<b>4410</b>	<b>6395*</b>	<b>4190</b>
2400 mm	kg	12 500*	8900	8600*	4800	6200*	3100	4700*	2000	2500*	1800
7'10"	lb	<b>27,563*</b>	<b>19,625</b>	<b>18,963*</b>	<b>10,584</b>	<b>13,671*</b>	<b>6836</b>	<b>10,364*</b>	<b>4410</b>	<b>5513*</b>	<b>3969</b>
2600 mm	kg	12 200*	9000	8600*	4800	6200*	3100	4800*	2100	2300*	1700
8'6"	lb	<b>26,901*</b>	<b>19,845</b>	<b>18,963*</b>	<b>10,584</b>	<b>13,671*</b>	<b>6836</b>	<b>10,584*</b>	<b>4631</b>	<b>5072*</b>	<b>3749</b>

**M316D† ● Rear Stabilizer Down**

Stick		3 m 9'10"		4.5 m 15'0"		6 m 20'0"		7.5 m 25'0"		At Max. Reach	
		Front	Side	Front	Side	Front	Side	Front	Side	Front	Side
2100 mm	kg	12 700*	11 100	8700*	5900	6100	3700	4100	2500	2900*	2300
6'11"	lb	<b>28,004*</b>	<b>24,476</b>	<b>19,184*</b>	<b>13,010</b>	<b>13,451</b>	<b>8159</b>	<b>9041</b>	<b>5513</b>	<b>6395*</b>	<b>5072</b>
2400 mm	kg	12 500*	11 200	8600*	5900	6000	3800	4100	2500	2500*	2200
7'10"	lb	<b>27,563*</b>	<b>24,696</b>	<b>18,963*</b>	<b>13,010</b>	<b>13,230</b>	<b>8379</b>	<b>9041</b>	<b>5513</b>	<b>5513*</b>	<b>4851</b>
2600 mm	kg	12 200*	11 100	8600*	5900	6000	3800	4200	2500	2300*	2100
8'6"	lb	<b>26,901*</b>	<b>24,476</b>	<b>18,963*</b>	<b>13,010</b>	<b>13,230</b>	<b>8379</b>	<b>9261</b>	<b>5513</b>	<b>5072*</b>	<b>4631</b>

**M316D† ● 4-Point Stabilizers Down**

Stick		3 m 9'10"		4.5 m 15'0"		6 m 20'0"		7.5 m 25'0"		At Max. Reach	
		Front	Side	Front	Side	Front	Side	Front	Side	Front	Side
2100 mm	kg	12 700*	12 700*	8700*	8300	6300*	5400	4200*	3700	2900*	2900*
6'11"	lb	<b>28,004*</b>	<b>28,004*</b>	<b>19,184*</b>	<b>18,302</b>	<b>13,892*</b>	<b>11,907</b>	<b>9261*</b>	<b>8159</b>	<b>6395*</b>	<b>6395*</b>
2400 mm	kg	12 500*	12 500*	8600*	8300	6200*	5400	4700*	3700	2500*	2500*
7'10"	lb	<b>27,563*</b>	<b>27,563*</b>	<b>18,963*</b>	<b>18,302</b>	<b>13,671*</b>	<b>11,907</b>	<b>10,364*</b>	<b>8159</b>	<b>5513*</b>	<b>5513*</b>
2600 mm	kg	12 200*	12 200*	8600*	8200	6200*	5500	4800*	3700	2300*	2300*
8'6"	lb	<b>26,901*</b>	<b>26,901*</b>	<b>18,963*</b>	<b>18,081</b>	<b>13,671*</b>	<b>12,128</b>	<b>10,584*</b>	<b>8159</b>	<b>5072*</b>	<b>5072*</b>

**M316D† ● Dozer and Stabilizer Down**

Stick		3 m 9'10"		4.5 m 15'0"		6 m 20'0"		7.5 m 25'0"		At Max. Reach	
		Front	Side	Front	Side	Front	Side	Front	Side	Front	Side
2100 mm	kg	12 700*	12 700*	8700*	7200	6300*	4600	4200*	3100	2900*	2900
6'11"	lb	<b>28,004*</b>	<b>28,004*</b>	<b>19,184*</b>	<b>15,876</b>	<b>13,892*</b>	<b>10,143</b>	<b>9261*</b>	<b>6836</b>	<b>6395*</b>	<b>6395</b>
2400 mm	kg	12 500*	12 500*	8600*	7100	6200*	4600	4700*	3100	2500*	2500*
7'10"	lb	<b>27,563*</b>	<b>27,563*</b>	<b>18,963*</b>	<b>15,656</b>	<b>13,671*</b>	<b>10,143</b>	<b>10,364*</b>	<b>6836</b>	<b>5513*</b>	<b>5513*</b>
2600 mm	kg	12 200*	12 200*	8600*	7100	6200*	4600	4800*	3100	2300*	2300*
8'6"	lb	<b>26,901*</b>	<b>26,901*</b>	<b>18,963*</b>	<b>15,656</b>	<b>13,671*</b>	<b>10,143</b>	<b>10,584*</b>	<b>6836</b>	<b>5072*</b>	<b>5072*</b>

\*Load limited by hydraulic capacity rather than tipping.  
 †This product has been discontinued.

**M318D†/M320D2 ● Rear Dozer Up**

Stick		3 m 9'10"		4.5 m 15'0"		6 m 20'0"		7.5 m 25'0"		At Max. Reach	
		Front	Side	Front	Side	Front	Side	Front	Side	Front	Side
2200 mm	kg	—	—	6600	3700	4300	2500	3100	1800	2800	1600
7'3"	lb	—	—	14,553	8159	9482	5513	6836	3969	6174	3528
2500 mm	kg	—	—	6700	3800	4300	2500	3100	1800	2700	1600
8'2"	lb	—	—	14,774	8379	9482	5513	6836	3969	5954	3528
2800 mm	kg	5000*	5000*	6600	3800	4300	2500	3100	1800	2500	1500
9'2"	lb	11,025*	11,025*	14,553	8379	9482	5513	6836	3969	5513	3308

**M318D†/M320D2 ● Rear Dozer Down**

Stick		3 m 9'10"		4.5 m 15'0"		6 m 20'0"		7.5 m 25'0"		At Max. Reach	
		Front	Side	Front	Side	Front	Side	Front	Side	Front	Side
2200 mm	kg	—	—	10 200*	4300	7100	2900	5000	2100	3800*	1900
7'3"	lb	—	—	22,491*	9482	15,656	6395	11,025	4631	8379*	4190
2500 mm	kg	—	—	10 200*	4400	7100	2900	5000	2100	2900*	1800
8'2"	lb	—	—	22,491*	9702	15,656	6395	11,025	4631	6395*	3969
2800 mm	kg	5000*	5000*	10 200*	4400	7100	2900	5000	2100	2600*	1700
9'2"	lb	11,025*	11,025*	22,491*	9702	15,656	6395	11,025	4631	5733*	3749

**M318D†/M320D2 ● Rear Stabilizer Down**

Stick		3 m 9'10"		4.5 m 15'0"		6 m 20'0"		7.5 m 25'0"		At Max. Reach	
		Front	Side	Front	Side	Front	Side	Front	Side	Front	Side
2200 mm	kg	—	—	9900	5400	6100	3600	4300	2600	3800*	2400
7'3"	lb	—	—	21,830	11,907	13,451	7938	9482	5733	8379*	5292
2500 mm	kg	—	—	10 000	5500	6200	3600	4400	2600	2900*	2200
8'2"	lb	—	—	22,050	12,128	13,671	7938	9702	5733	6395*	4851
2800 mm	kg	5000*	5000*	10 000	5500	6200	3600	4300	2600	2600*	2100
9'2"	lb	11,025*	11,025*	22,050	12,128	13,671	7938	9482	5733	5733*	4631

**M318D†/M320D2 ● 4-Point Stabilizers Down**

Stick		3 m 9'10"		4.5 m 15'0"		6 m 20'0"		7.5 m 25'0"		At Max. Reach	
		Front	Side	Front	Side	Front	Side	Front	Side	Front	Side
2200 mm	kg	—	—	10 200*	8300	7400*	5300	5700*	3800	3800*	3500
7'3"	lb	—	—	22,491*	18,302	16,317*	11,687	12,569*	8379	8379*	7718
2500 mm	kg	—	—	10 200*	8400	7400*	5400	5700*	3800	2900*	2900*
8'2"	lb	—	—	22,491*	18,522	16,317*	11,907	12,569*	8379	6395*	6395*
2800 mm	kg	5000*	5000*	10 200*	8400	7300*	5300	5700*	3800	2600*	2600*
9'2"	lb	11,025*	11,025*	22,491*	18,522	16,097*	11,687	12,569*	8379	5733*	5733*

**M318D†/M320D2 ● Dozer and Stabilizer Down**

Stick		3 m 9'10"		4.5 m 15'0"		6 m 20'0"		7.5 m 25'0"		At Max. Reach	
		Front	Side	Front	Side	Front	Side	Front	Side	Front	Side
2200 mm	kg	—	—	10 200*	6800	7400*	4400	5700*	3200	3800*	2900
7'3"	lb	—	—	22,491*	14,994	16,317*	9702	12,569*	7056	8379*	6395
2500 mm	kg	—	—	10 200*	6900	7400*	4500	5700*	3200	2900*	2800
8'2"	lb	—	—	22,491*	15,215	16,317*	9923	12,569*	7056	6395*	6174
2800 mm	kg	5000*	5000*	10 200*	6900	7300*	4500	5700*	3200	2600*	2600*
9'2"	lb	11,025*	11,025*	22,491*	15,215	16,097*	9923	12,569*	7056	5733*	5733*

\*Load limited by hydraulic capacity rather than tipping.

†This product has been discontinued.

**M318D†/M320D2 ● Rear Dozer Up**

Stick		3 m 9'10"		4.5 m 15'0"		6 m 20'0"		7.5 m 25'0"		At Max. Reach	
		Front	Side	Front	Side	Front	Side	Front	Side	Front	Side
2200 mm	kg	14 500	8000	7500	4400	4700	2800	3100	1800	2800	1600
7'3"	lb	<b>31,973</b>	<b>17,640</b>	<b>16,538</b>	<b>9702</b>	<b>10,364</b>	<b>6174</b>	<b>6836</b>	<b>3969</b>	<b>6174</b>	<b>3528</b>
2500 mm	kg	14 500	8100	7500	4500	4800	2900	3200	1900	2700*	1500
8'2"	lb	<b>31,973</b>	<b>17,861</b>	<b>16,538</b>	<b>9923</b>	<b>10,584</b>	<b>6395</b>	<b>7056</b>	<b>4190</b>	<b>5954*</b>	<b>3308</b>
2800 mm	kg	14 100	8200	7400	4500	4900	3000	3200	1900	2300*	1400
9'2"	lb	<b>31,091</b>	<b>18,081</b>	<b>16,317</b>	<b>9923</b>	<b>10,805</b>	<b>6615</b>	<b>7056</b>	<b>4190</b>	<b>5072*</b>	<b>3087</b>

**M318D†/M320D2 ● Rear Dozer Down**

Stick		3 m 9'10"		4.5 m 15'0"		6 m 20'0"		7.5 m 25'0"		At Max. Reach	
		Front	Side	Front	Side	Front	Side	Front	Side	Front	Side
2200 mm	kg	15 000*	9500	10 100*	5100	7300*	3300	5000	2100	3500*	1900
7'3"	lb	<b>33,075*</b>	<b>20,948</b>	<b>22,271*</b>	<b>11,246</b>	<b>16,097*</b>	<b>7277</b>	<b>11,025</b>	<b>4631</b>	<b>7718*</b>	<b>4190</b>
2500 mm	kg	14 600*	9600	10 100*	5200	7300*	3400	5100	2200	2700*	1800
8'2"	lb	<b>32,193*</b>	<b>21,168</b>	<b>22,271*</b>	<b>11,466</b>	<b>16,097*</b>	<b>7497</b>	<b>11,246</b>	<b>4851</b>	<b>5954*</b>	<b>3969</b>
2800 mm	kg	14 100*	9700	10 100*	5200	7200*	3400	5100	2200	2300*	1700
9'2"	lb	<b>31,091*</b>	<b>21,389</b>	<b>22,271*</b>	<b>11,466</b>	<b>15,876*</b>	<b>7497</b>	<b>11,246</b>	<b>4851</b>	<b>5072*</b>	<b>3749</b>

7

**M318D†/M320D2 ● Rear Stabilizer Down**

Stick		3 m 9'10"		4.5 m 15'0"		6 m 20'0"		7.5 m 25'0"		At Max. Reach	
		Front	Side	Front	Side	Front	Side	Front	Side	Front	Side
2200 mm	kg	15 000*	12 100	10 100*	6300	6600	4000	4400	2600	3500*	2400
7'3"	lb	<b>33,075*</b>	<b>26,681</b>	<b>22,271*</b>	<b>13,892</b>	<b>14,553</b>	<b>8820</b>	<b>9702</b>	<b>5733</b>	<b>7718*</b>	<b>5292</b>
2500 mm	kg	14 600*	12 100	10 100*	6400	6600	4100	4400	2700	2700*	2200
8'2"	lb	<b>32,193*</b>	<b>26,681</b>	<b>22,271*</b>	<b>14,112</b>	<b>14,553</b>	<b>9041</b>	<b>9702</b>	<b>5954</b>	<b>5954*</b>	<b>4851</b>
2800 mm	kg	14 100*	12 000	10 100*	6400	6500	4100	4500	2700	2300*	2100
9'2"	lb	<b>31,091*</b>	<b>26,460</b>	<b>22,271*</b>	<b>14,112</b>	<b>14,333</b>	<b>9041</b>	<b>9923</b>	<b>5954</b>	<b>5072*</b>	<b>4631</b>

**M318D†/M320D2 ● 4-Point Stabilizers Down**

Stick		3 m 9'10"		4.5 m 15'0"		6 m 20'0"		7.5 m 25'0"		At Max. Reach	
		Front	Side	Front	Side	Front	Side	Front	Side	Front	Side
2200 mm	kg	15 000*	15 000*	10 100*	8900	7300*	5700	5500*	3900	3500*	3500*
7'3"	lb	<b>33,075*</b>	<b>33,075*</b>	<b>22,271*</b>	<b>19,625</b>	<b>16,097*</b>	<b>12,569</b>	<b>12,128*</b>	<b>8600</b>	<b>7718*</b>	<b>7718*</b>
2500 mm	kg	14 600*	14 600*	10 100*	8900	7300*	5800	5700*	3900*	2700*	2700*
8'2"	lb	<b>32,193*</b>	<b>32,193*</b>	<b>22,271*</b>	<b>19,625</b>	<b>16,097*</b>	<b>12,789</b>	<b>12,569*</b>	<b>8599*</b>	<b>5954*</b>	<b>5954*</b>
2800 mm	kg	14 100*	14 100*	10 100*	8900	7300*	5800	5700*	3900	2300*	2300*
9'2"	lb	<b>31,091*</b>	<b>31,091*</b>	<b>22,271*</b>	<b>19,625</b>	<b>16,097*</b>	<b>12,789</b>	<b>12,569*</b>	<b>8600</b>	<b>5072*</b>	<b>5072*</b>

**M318D†/M320D2 ● Dozer and Stabilizer Down**

Stick		3 m 9'10"		4.5 m 15'0"		6 m 20'0"		7.5 m 25'0"		At Max. Reach	
		Front	Side	Front	Side	Front	Side	Front	Side	Front	Side
2200 mm	kg	15 000*	14 800	10 100*	7600	7300*	4900	5500*	3200	3500*	2900
7'3"	lb	<b>33,075*</b>	<b>32,634</b>	<b>22,271*</b>	<b>16,758</b>	<b>16,097*</b>	<b>10,805</b>	<b>12,128*</b>	<b>7056</b>	<b>7718*</b>	<b>6395</b>
2500 mm	kg	14 600*	14 600*	10 100*	7600	7300*	4900	5700*	3300	2700*	2700*
8'2"	lb	<b>32,193*</b>	<b>32,193*</b>	<b>22,271*</b>	<b>16,758</b>	<b>16,097*</b>	<b>10,805</b>	<b>12,569*</b>	<b>7277</b>	<b>5954*</b>	<b>5954*</b>
2800 mm	kg	14 100*	14 100*	10 100*	7600	7300*	5000	5700*	3300	2300*	2300*
9'2"	lb	<b>31,091*</b>	<b>31,091*</b>	<b>22,271*</b>	<b>16,758</b>	<b>16,097*</b>	<b>11,025</b>	<b>12,569*</b>	<b>7277</b>	<b>5072*</b>	<b>5072*</b>

\*Load limited by hydraulic capacity rather than tipping.  
 †This product has been discontinued.



**M322D†/M322D2 ● Rear Dozer Up**

Stick		3 m 9'10"		4.5 m 15'0"		6 m 20'0"		7.5 m 25'0"		At Max. Reach	
		Front	Side	Front	Side	Front	Side	Front	Side	Front	Side
2200 mm	kg	—	—	7200	4400	4700	2900	3400	2100	2800	1800
7'3"	lb	—	—	15,876	9702	10,364	6395	7497	4631	6174	3969
2500 mm	kg	—	—	7200	4400	4700	2900	3400	2100	2600*	1700
8'2"	lb	—	—	15,876	9702	10,364	6395	7497	4631	5733*	3749
2900 mm	kg	—	—	7200	4400	4700	2900	3400	2100	2200*	1500
9'6"	lb	—	—	15,876	9702	10,364	6395	7497	4631	4851*	3308

**M322D†/M322D2 ● Rear Dozer Down**

Stick		3 m 9'10"		4.5 m 15'0"		6 m 20'0"		7.5 m 25'0"		At Max. Reach	
		Front	Side	Front	Side	Front	Side	Front	Side	Front	Side
2200 mm	kg	—	—	11 800*	5100	8500	3400	5900	2500	2900*	2000
7'3"	lb	—	—	26,019*	11,246	18,743	7497	13,010	5513	6395*	4410
2500 mm	kg	—	—	11 900*	5100	8500	3400	5900	2500	2600*	1900
8'2"	lb	—	—	26,240*	11,246	18,743	7497	13,010	5513	5733*	4190
2900 mm	kg	—	—	11 800*	5100	8500*	3400	5800	2400	2200*	1800
9'6"	lb	—	—	26,019*	11,246	18,743*	7497	12,789	5292	4851*	3969

**M322D†/M322D2 ● Rear Stabilizer Down**

Stick		3 m 9'10"		4.5 m 15'0"		6 m 20'0"		7.5 m 25'0"		At Max. Reach	
		Front	Side	Front	Side	Front	Side	Front	Side	Front	Side
2200 mm	kg	—	—	11 800*	6400	7300	4200	5100	3100	2900*	2500
7'3"	lb	—	—	26,019*	14,112	16,097	9261	11,246	6836	6395*	5513
2500 mm	kg	—	—	11 900*	6400	7300	4200	5100	3100	2600*	2400
8'2"	lb	—	—	26,240*	14,112	16,097	9261	11,246	6836	5733*	5292
2900 mm	kg	—	—	11 800*	6400	7300	4200	5100	3000	2200*	2200
9'6"	lb	—	—	26,019*	14,112	16,097	9261	11,246	6615	4851*	4851

**M322D†/M322D2 ● 4-Point Stabilizers Down**

Stick		3 m 9'10"		4.5 m 15'0"		6 m 20'0"		7.5 m 25'0"		At Max. Reach	
		Front	Side	Front	Side	Front	Side	Front	Side	Front	Side
2200 mm	kg	—	—	11 800*	10 100	8600*	6400	6600*	4600	2900*	2900*
7'3"	lb	—	—	26,019*	22,271	18,963*	14,112	14,553*	10,143	6395*	6395*
2500 mm	kg	—	—	11 900*	10 100	8600*	6400	6600*	4600	2600*	2600*
8'2"	lb	—	—	26,240*	22,271	18,963*	14,112	14,553*	10,143	5733*	5733*
2900 mm	kg	—	—	11 800*	10 100	8500*	6200	6600*	4500	2200*	2200*
9'6"	lb	—	—	26,019*	22,271	18,743*	13,671	14,553*	9923	4851*	4851*

**M322D†/M322D2 ● Dozer and Stabilizer Down**

Stick		3 m 9'10"		4.5 m 15'0"		6 m 20'0"		7.5 m 25'0"		At Max. Reach	
		Front	Side	Front	Side	Front	Side	Front	Side	Front	Side
2200 mm	kg	—	—	11 800*	8300	8600*	5400	6600*	3900	2900*	2900*
7'3"	lb	—	—	26,019*	18,302	18,963*	11,907	14,553*	8600	6395*	6395*
2500 mm	kg	—	—	11 900*	8300	8600*	5400	6600*	3900	2600*	2600*
8'2"	lb	—	—	26,240*	18,302	18,963*	11,907	14,553*	8600	5733*	5733*
2900 mm	kg	—	—	11 800*	8300	8500*	5400	6600*	3800	2200*	2200*
9'6"	lb	—	—	26,019*	18,302	18,743*	11,907	14,553*	8379	4851*	4851*

\*Load limited by hydraulic capacity rather than tipping.

†This product has been discontinued.

**M322D†/M322D2 ● Rear Dozer Up**

Stick		3 m 9'10"		4.5 m 15'0"		6 m 20'0"		7.5 m 25'0"		At Max. Reach	
		Front	Side	Front	Side	Front	Side	Front	Side	Front	Side
2200 mm	kg	16 100	9500	8300	5300	5300	3500	3500	2200	2700*	1800
7'3"	lb	35,501	20,948	18,302	11,687	11,687	7718	7718	4851	5954*	3969
2500 mm	kg	16 100	9800	8300	5400	5300	3500	3500	5300	2500*	1700
8'2"	lb	35,501	21,609	18,302	11,907	11,687	7718	7718	11,687	5513*	3749
2900 mm	kg	15 800	9900	8200	5400	5400	3500	3600	2300	2100*	1500
9'6"	lb	34,839	21,830	18,081	11,907	11,907	7718	7938	5072	4631*	3308

**M322D†/M322D2 ● Rear Dozer Down**

Stick		3 m 9'10"		4.5 m 15'0"		6 m 20'0"		7.5 m 25'0"		At Max. Reach	
		Front	Side	Front	Side	Front	Side	Front	Side	Front	Side
2200 mm	kg	16 700*	11 300	11 800*	6100	8500*	4000	6100	2600	2700*	2100
7'3"	lb	36,825*	24,917	26,019*	13,451	18,743*	8820	13,451	5733	5954*	4631
2500 mm	kg	16 400*	11 600	11 800*	6200	8500*	4000	6100	2600	2500*	2000
8'2"	lb	36,162*	25,578	26,019*	13,671	18,743*	8820	13,451	5733	5513*	4410
2900 mm	kg	15 800*	11 700	11 700*	6200	8400*	4000	6100	2700	2100*	1800
9'6"	lb	34,839*	25,799	25,799*	13,671	18,522*	8820	13,451	5954	4631*	3969

**M322D†/M322D2 ● Rear Stabilizer Down**

Stick		3 m 9'10"		4.5 m 15'0"		6 m 20'0"		7.5 m 25'0"		At Max. Reach	
		Front	Side	Front	Side	Front	Side	Front	Side	Front	Side
2200 mm	kg	16 700*	16 700	11 800*	10 800	8500	7100	6700	4700	2700*	2700
7'3"	lb	36,825*	36,824	26,019*	23,814	18,743	15,656	14,774	10,364	5954*	5954
2500 mm	kg	16 400*	14 600	11 800*	7600	7800	4900	5300	6200	2500*	2400
8'2"	lb	36,162*	32,193	26,019*	16,758	17,199	10,805	11,687	13,671	5513*	5292
2900 mm	kg	15 800*	14 400	11 700*	7500	7700	4900	5400	3300	2100*	2100*
9'6"	lb	34,839*	31,752	25,799*	16,538	16,979	10,805	11,907	7277	4631*	4631*

**M322D†/M322D2 ● 4-Point Stabilizers Down**

Stick		3 m 9'10"		4.5 m 15'0"		6 m 20'0"		7.5 m 25'0"		At Max. Reach	
		Front	Side	Front	Side	Front	Side	Front	Side	Front	Side
2200 mm	kg	16 700*	16 700*	11 800*	10 800	8500*	7100	6700*	4700	2700*	2700*
7'3"	lb	36,825*	36,825*	26,019*	23,814	18,743*	15,656	14,744*	10,364	5954*	5954*
2500 mm	kg	16 400*	16 400*	11 800*	10 800	8500*	7000	6600*	4700	2500*	2500*
8'2"	lb	36,162*	36,162*	26,019*	23,814	18,743*	15,435	14,553*	10,364	5513*	5513*
2900 mm	kg	15 800*	15 800*	11 700*	10 700	8400*	6900	6500*	4800	2100*	2100*
9'6"	lb	34,839*	34,839*	25,799*	23,594	18,522*	15,215	14,333*	10,584	4631*	4631*

**M322D†/M322D2 ● Dozer and Stabilizer Down**

Stick		3 m 9'10"		4.5 m 15'0"		6 m 20'0"		7.5 m 25'0"		At Max. Reach	
		Front	Side	Front	Side	Front	Side	Front	Side	Front	Side
2200 mm	kg	16 700*	16 700*	11 800*	9300	8500*	6100	6700*	4000	2700*	2700*
7'3"	lb	36,825*	36,825*	26,019*	20,507	18,743*	13,451	14,744*	8820	5954*	5954*
2500 mm	kg	16 400*	16 400*	11 800*	9200	8500*	6100	6600*	4000	2500*	2500*
8'2"	lb	36,162*	36,162*	26,019*	20,286	18,743*	13,451	14,553*	8820	5513*	5513*
2900 mm	kg	15 800*	15 800*	11 700*	9100	8500*	6000	6500*	4100	2100*	2100*
9'6"	lb	34,839*	34,839*	25,799*	20,066	18,743*	13,230	14,333*	9041	4631*	4631*

\*Load limited by hydraulic capacity rather than tipping.  
 †This product has been discontinued.

# Hydraulic Excavators

## Lifting Capacity At Ground Level

- M318F ● One-Piece Boom
- 3400 kg (7496 lb) Counterweight

### M318F ● Rear Dozer Up

Stick		3 m 9'10"		4.5 m 15'0"		6 m 20'0"		7.5 m 25'0"		At Max. Reach	
		Rear	Side	Rear	Side	Rear	Side	Rear	Side	Rear	Side
2100 mm 6'11"	kg lb	—	—	4100 9039	3500 7716	2750 6063	2400 5291	—	—	2200 4850	1900 4189
2400 mm 7'10"	kg lb	—	—	4100 9039	3500 7716	2750 6063	2350 5181	—	—	2050 4519	1800 3968
2600 mm 8'6"	kg lb	4400* 9700	4400* 9700	4100 9039	3500 7716	2750 6063	2350 5181	2000 4409	1750 3858	2000 4409	1700 3748

### M318F ● Rear Dozer Up

Stick		3 m 9'10"		4.5 m 15'0"		6 m 20'0"		7.5 m 25'0"		At Max. Reach	
		Front	Side	Front	Side	Front	Side	Front	Side	Front	Side
2100 mm 6'11"	kg lb	—	—	6200 13,669	3500 7716	4100 9039	2400 5291	—	—	3200 7055	1900 4189
2400 mm 7'10"	kg lb	—	—	6200 13,669	3500 7716	4050 8929	2350 5181	—	—	3050 6724	1800 3968
2600 mm 8'6"	kg lb	4400* 9700	4400* 9700	6200 13,669	3500 7716	4050 8929	2350 5181	2950 6504	1750 3858	2900 6393	1700 3748

### M318F ● Rear Dozer Down

Stick		3 m 9'10"		4.5 m 15'0"		6 m 20'0"		7.5 m 25'0"		At Max. Reach	
		Rear	Side	Rear	Side	Rear	Side	Rear	Side	Rear	Side
2100 mm 6'11"	kg lb	—	—	8800* 19,401	4100 9039	6350 13,999	2750 6063	—	—	4250* 9370	2200 4850
2400 mm 7'10"	kg lb	—	—	8850* 19,511	4100 9039	6350 13,999	2750 6063	—	—	3650* 8047	2050 4519
2600 mm 8'6"	kg lb	4400* 9700	4400* 9700	8850* 19,511	4100 9039	6350 13,999	2750 6063	4000* 8818	2000 4409	3300* 7275	2000 4409

### M318F ● Front Dozer and Rear Stabilizer Down

Stick		3 m 9'10"		4.5 m 15'0"		6 m 20'0"		7.5 m 25'0"		At Max. Reach	
		Rear	Side	Rear	Side	Rear	Side	Rear	Side	Rear	Side
2100 mm 6'11"	kg lb	—	—	8800* 19,401	6550 14,440	6400* 14,110	4300 9480	—	—	4250* 9370	3400 7496
2400 mm 7'10"	kg lb	—	—	8850* 19,511	6550 14,440	6400 14,110	4250 9370	—	—	3650* 8047	3200 7055
2600 mm 8'6"	kg lb	4400* 9700	4400* 9700	8850* 19,511	6550 14,440	6400 14,110	4250 9370	4000* 8818	3100 6834	3300* 7275	3050 6724

### M318F ● 4-Point Stabilizer Down

Stick		3 m 9'10"		4.5 m 15'0"		6 m 20'0"		7.5 m 25'0"		At Max. Reach	
		Front	Side	Front	Side	Front	Side	Front	Side	Front	Side
2100 mm 6'11"	kg lb	—	—	8800* 19,401	7800 17,196	6400* 14,110	5000 11,023	—	—	4250* 9370	3950 8708
2400 mm 7'10"	kg lb	—	—	8850* 19,511	7800 17,196	6450* 14,220	5000 11,023	—	—	3650* 8047	3650* 8047
2600 mm 8'6"	kg lb	4400* 9700	4400* 9700	8850* 19,511	7800 17,196	6450* 14,220	5000 11,023	4000* 8818	3650 8047	3300* 7275	3300* 7275

\*Indicates that the load is limited by hydraulic lifting capacity rather than tipping load.

**NOTE:** Oscillating axle needs to be locked. Weight of all lifting accessories must be subtracted from the lifting capacities.

All lift capacities calculated and rated per ISO 10567:2007. Rated loads do not exceed 87% of hydraulic lift capacity or 75% of tipping load.

Lifting capacities are based on the machine standing on a firm uniform supporting surface. The load point is the center line of the bucket pivot mounting pin on the stick.

Lifting Capacity At Ground Level  
 ● M318F ● One-Piece Boom  
 ● 3900 kg (8598 lb) Counterweight

**Hydraulic  
Excavators**

**M318F ● Rear Dozer Up**

Stick		3 m 9'10"		4.5 m 15'0"		6 m 20'0"		7.5 m 25'0"		At Max. Reach	
		Rear	Side	Rear	Side	Rear	Side	Rear	Side	Rear	Side
2100 mm 6'11"	kg lb	—	—	4450 9811	3800 8378	3000 6614	2600 5732	—	—	2400 5291	2100 4630
2400 mm 7'10"	kg lb	—	—	4450 9811	3800 8378	3000 6614	2600 5732	—	—	2250 4960	1950 4299
2600 mm 8'6"	kg lb	4400* 9700	4400* 9700	4450 9811	3800 8378	3000 6614	2600 5732	2200 4850	1900 4189	2150 4740	1900 4189

**M318F ● Rear Dozer Up**

Stick		3 m 9'10"		4.5 m 15'0"		6 m 20'0"		7.5 m 25'0"		At Max. Reach	
		Front	Side	Front	Side	Front	Side	Front	Side	Front	Side
2100 mm 6'11"	kg lb	—	—	6600 14,551	3800 8378	4350 9590	2600 5732	—	—	3450 7606	2100 4630
2400 mm 7'10"	kg lb	—	—	6600 14,551	3800 8378	4350 9590	2600 5732	—	—	3250 7165	1950 4299
2600 mm 8'6"	kg lb	4400* 9700	4400* 9700	6600 14,551	3800 8378	4350 9590	2600 5732	3200 7055	1900 4189	3150 6945	1900 4189

**M318F ● Rear Dozer Down**

Stick		3 m 9'10"		4.5 m 15'0"		6 m 20'0"		7.5 m 25'0"		At Max. Reach	
		Rear	Side	Rear	Side	Rear	Side	Rear	Side	Rear	Side
2100 mm 6'11"	kg lb	—	—	8800* 19,401	4400 9700	6400* 14,110	3000 6614	—	—	4250* 9370	2400 5291
2400 mm 7'10"	kg lb	—	—	8850* 19,511	4400 9700	6450* 14,220	3000 6614	—	—	3650* 8047	2250 4960
2600 mm 8'6"	kg lb	4400* 9700	4400* 9700	8850* 19,511	4400 9700	6450* 14,220	3000 6614	4000* 8818	2200 4850	3300* 7275	2150 4740

**M318F ● Front Dozer and Rear Stabilizer Down**

Stick		3 m 9'10"		4.5 m 15'0"		6 m 20'0"		7.5 m 25'0"		At Max. Reach	
		Rear	Side	Rear	Side	Rear	Side	Rear	Side	Rear	Side
2100 mm 6'11"	kg lb	—	—	8800* 19,401	6950 15,322	6400* 14,110	4550 10,031	—	—	4250* 9370	3600 7937
2400 mm 7'10"	kg lb	—	—	8850* 19,511	6950 15,322	6450* 14,220	4550 10,031	—	—	3650* 8047	3400 7496
2600 mm 8'6"	kg lb	4400* 9700	4400* 9700	8850* 19,511	6950 15,322	6450* 14,220	4550 10,031	4000* 8818	3350 7385	3300* 7275	3300 7275

**M318F ● 4-Point Stabilizer Down**

Stick		3 m 9'10"		4.5 m 15'0"		6 m 20'0"		7.5 m 25'0"		At Max. Reach	
		Front	Side	Front	Side	Front	Side	Front	Side	Front	Side
2100 mm 6'11"	kg lb	—	—	8800* 19,401	8250 18,188	6400* 14,110	5350 11,795	—	—	4250* 9370	4200 9259
2400 mm 7'10"	kg lb	—	—	8850* 19,511	8250 18,188	6450* 14,220	5300 11,684	—	—	3650* 8047	3650* 8047
2600 mm 8'6"	kg lb	4400* 9700	4400* 9700	8850* 19,511	8250 18,188	6450* 14,220	5300 11,684	4000* 8818	3850 8488	3300* 7275	3300* 7275

\*Indicates that the load is limited by hydraulic lifting capacity rather than tipping load.

**NOTE:** Oscillating axle needs to be locked. Weight of all lifting accessories must be subtracted from the lifting capacities.

All lift capacities calculated and rated per ISO 10567:2007. Rated loads do not exceed 87% of hydraulic lift capacity or 75% of tipping load.

Lifting capacities are based on the machine standing on a firm uniform supporting surface. The load point is the center line of the bucket pivot mounting pin on the stick.

# Hydraulic Excavators

## Lifting Capacity At Ground Level

- M318F ● Hydraulically Adjustable Boom
- 3400 kg (7496 lb) Counterweight

### M318F ● Rear Dozer Up

Stick		3 m 9'10"		4.5 m 15'0"		6 m 20'0"		7.5 m 25'0"		At Max. Reach	
		Rear	Side	Rear	Side	Rear	Side	Rear	Side	Rear	Side
2100 mm	kg	—	—	4000	3400	2700	2300	—	—	2050	1750
6'11"	lb	—	—	<b>8818</b>	<b>7496</b>	<b>5952</b>	<b>5071</b>	—	—	<b>4519</b>	<b>3858</b>
2400 mm	kg	—	—	4000	3350	2650	2300	1950	1700	1950	1650
7'10"	lb	—	—	<b>8818</b>	<b>7385</b>	<b>5842</b>	<b>5071</b>	<b>4299</b>	<b>3748</b>	<b>4299</b>	<b>3638</b>
2600 mm	kg	—	—	4000	3350	2650	2300	1950	1700	1850	1600
8'6"	lb	—	—	<b>8818</b>	<b>7385</b>	<b>5842</b>	<b>5071</b>	<b>4299</b>	<b>3748</b>	<b>4079</b>	<b>3527</b>

### M318F ● Rear Dozer Up

Stick		3 m 9'10"		4.5 m 15'0"		6 m 20'0"		7.5 m 25'0"		At Max. Reach	
		Front	Side	Front	Side	Front	Side	Front	Side	Front	Side
2100 mm	kg	—	—	6100	3400	4050	2300	—	—	3050	1750
6'11"	lb	—	—	<b>13,448</b>	<b>7496</b>	<b>8929</b>	<b>5071</b>	—	—	<b>6724</b>	<b>3858</b>
2400 mm	kg	—	—	6100	3350	4000	2300	2950	1700	2900	1650
7'10"	lb	—	—	<b>13,448</b>	<b>7385</b>	<b>8818</b>	<b>5071</b>	<b>6504</b>	<b>3748</b>	<b>6393</b>	<b>3638</b>
2600 mm	kg	—	—	6100	3350	4000	2300	2950	1700	2800	1600
8'6"	lb	—	—	<b>13,448</b>	<b>7385</b>	<b>8818</b>	<b>5071</b>	<b>6504</b>	<b>3748</b>	<b>6173</b>	<b>3527</b>

### M318F ● Rear Dozer Down

Stick		3 m 9'10"		4.5 m 15'0"		6 m 20'0"		7.5 m 25'0"		At Max. Reach	
		Rear	Side	Rear	Side	Rear	Side	Rear	Side	Rear	Side
2100 mm	kg	—	—	8500*	4000	6250*	2700	—	—	4100*	2050
6'11"	lb	—	—	<b>18,739</b>	<b>8818</b>	<b>13,779</b>	<b>5952</b>	—	—	<b>9039</b>	<b>4519</b>
2400 mm	kg	—	—	8600*	3950	6300*	2700	4500	1950	3500*	1950
7'10"	lb	—	—	<b>18,960</b>	<b>8708</b>	<b>13,889</b>	<b>5952</b>	<b>9921</b>	<b>4299</b>	<b>7716</b>	<b>4299</b>
2600 mm	kg	—	—	8650*	3950	6200*	2700	4500	1950	3200*	1850
8'6"	lb	—	—	<b>19,070</b>	<b>8708</b>	<b>13,669</b>	<b>5952</b>	<b>9921</b>	<b>4299</b>	<b>7055</b>	<b>4079</b>

### M318F ● Front Dozer and Rear Stabilizer Down

Stick		3 m 9'10"		4.5 m 15'0"		6 m 20'0"		7.5 m 25'0"		At Max. Reach	
		Rear	Side	Rear	Side	Rear	Side	Rear	Side	Rear	Side
2100 mm	kg	—	—	8500*	6450	6250*	4250	—	—	4100*	3200
6'11"	lb	—	—	<b>18,739</b>	<b>14,220</b>	<b>13,779</b>	<b>9370</b>	—	—	<b>9039</b>	<b>7055</b>
2400 mm	kg	—	—	8600*	6450	6300*	4250	4600	3100	3500*	3050
7'10"	lb	—	—	<b>18,960</b>	<b>14,220</b>	<b>13,889</b>	<b>9370</b>	<b>10,141</b>	<b>6834</b>	<b>7716</b>	<b>6724</b>
2600 mm	kg	—	—	8650*	6450	6200*	4250	4550	3100	3200*	2900
8'6"	lb	—	—	<b>19,070</b>	<b>14,220</b>	<b>13,669</b>	<b>9370</b>	<b>10,031</b>	<b>6834</b>	<b>7055</b>	<b>6393</b>

### M318F ● 4-Point Stabilizer Down

Stick		3 m 9'10"		4.5 m 15'0"		6 m 20'0"		7.5 m 25'0"		At Max. Reach	
		Front	Side	Front	Side	Front	Side	Front	Side	Front	Side
2100 mm	kg	—	—	8500*	7750	6250*	5000	—	—	4100*	3750
6'11"	lb	—	—	<b>18,739</b>	<b>17,086</b>	<b>13,779</b>	<b>11,023</b>	—	—	<b>9039</b>	<b>8267</b>
2400 mm	kg	—	—	8600*	7750	6300*	5000	4600*	3600	3500*	3500*
7'10"	lb	—	—	<b>18,960</b>	<b>17,086</b>	<b>13,889</b>	<b>11,023</b>	<b>10,141</b>	<b>7937</b>	<b>7716</b>	<b>7716</b>
2600 mm	kg	—	—	8650*	7750	6200*	4950	4650*	3600	3200*	3200*
8'6"	lb	—	—	<b>19,070</b>	<b>17,086</b>	<b>13,669</b>	<b>10,913</b>	<b>10,251</b>	<b>7937</b>	<b>7055</b>	<b>7055</b>

\*Indicates that the load is limited by hydraulic lifting capacity rather than tipping load.

**NOTE:** Oscillating axle needs to be locked. Weight of all lifting accessories must be subtracted from the lifting capacities.

All lift capacities calculated and rated per ISO 10567:2007. Rated loads do not exceed 87% of hydraulic lift capacity or 75% of tipping load.

Lifting capacities are based on the machine standing on a firm uniform supporting surface. The load point is the center line of the bucket pivot mounting pin on the stick.

- M318F ● Hydraulically Adjustable Boom
- 3900 kg (8598 lb) Counterweight

## Hydraulic Excavators

### M318F ● Rear Dozer Up

Stick		3 m 9'10"		4.5 m 15'0"		6 m 20'0"		7.5 m 25'0"		At Max. Reach	
		Rear	Side	Rear	Side	Rear	Side	Rear	Side	Rear	Side
2100 mm	kg	—	—	4350	3700	2950	2500	—	—	2250	1950
6'11"	lb	—	—	<b>9590</b>	<b>8157</b>	<b>6504</b>	<b>5512</b>	—	—	<b>4960</b>	<b>4299</b>
2400 mm	kg	—	—	4350	3700	2900	2500	2150	1850	2100	1850
7'10"	lb	—	—	<b>9590</b>	<b>8157</b>	<b>6393</b>	<b>5512</b>	<b>4740</b>	<b>4079</b>	<b>4630</b>	<b>4079</b>
2600 mm	kg	—	—	4350	3700	2900	2500	2150	1850	2050	1750
8'6"	lb	—	—	<b>9590</b>	<b>8157</b>	<b>6393</b>	<b>5512</b>	<b>4740</b>	<b>4079</b>	<b>4519</b>	<b>3858</b>

### M318F ● Rear Dozer Up

Stick		3 m 9'10"		4.5 m 15'0"		6 m 20'0"		7.5 m 25'0"		At Max. Reach	
		Front	Side	Front	Side	Front	Side	Front	Side	Front	Side
2100 mm	kg	—	—	6550	3700	4300	2500	—	—	3300	1950
6'11"	lb	—	—	<b>14,440</b>	<b>8157</b>	<b>9480</b>	<b>5512</b>	—	—	<b>7275</b>	<b>4299</b>
2400 mm	kg	—	—	6550	3700	4300	2500	3150	1850	3100	1850
7'10"	lb	—	—	<b>14,440</b>	<b>8157</b>	<b>9480</b>	<b>5512</b>	<b>6945</b>	<b>4079</b>	<b>6834</b>	<b>4079</b>
2600 mm	kg	—	—	6550	3700	4300	2500	3150	1850	3000	1750
8'6"	lb	—	—	<b>14,440</b>	<b>8157</b>	<b>9480</b>	<b>5512</b>	<b>6945</b>	<b>4079</b>	<b>6614</b>	<b>3858</b>

### M318F ● Rear Dozer Down

Stick		3 m 9'10"		4.5 m 15'0"		6 m 20'0"		7.5 m 25'0"		At Max. Reach	
		Rear	Side	Rear	Side	Rear	Side	Rear	Side	Rear	Side
2100 mm	kg	—	—	8500*	4300	6250*	2950	—	—	4100*	2250
6'11"	lb	—	—	<b>18,739</b>	<b>9480</b>	<b>13,779</b>	<b>6504</b>	—	—	<b>9039</b>	<b>4960</b>
2400 mm	kg	—	—	8600*	4300	6300*	2900	4600*	2150	3500*	2100
7'10"	lb	—	—	<b>18,960</b>	<b>9480</b>	<b>13,889</b>	<b>6393</b>	<b>10,141</b>	<b>4740</b>	<b>7716</b>	<b>4630</b>
2600 mm	kg	—	—	8650*	4300	6200*	2900	4650*	2150	3200*	2050
8'6"	lb	—	—	<b>19,070</b>	<b>9480</b>	<b>13,669</b>	<b>6393</b>	<b>10,251</b>	<b>4740</b>	<b>7055</b>	<b>4519</b>

### M318F ● Front Dozer and Rear Stabilizer Down

Stick		3 m 9'10"		4.5 m 15'0"		6 m 20'0"		7.5 m 25'0"		At Max. Reach	
		Rear	Side	Rear	Side	Rear	Side	Rear	Side	Rear	Side
2100 mm	kg	—	—	8500*	6900	6250*	4550	—	—	4100*	3450
6'11"	lb	—	—	<b>18,739</b>	<b>15,212</b>	<b>13,779</b>	<b>10,031</b>	—	—	<b>9039</b>	<b>7606</b>
2400 mm	kg	—	—	8600*	6900	6300*	4500	4600*	3300	3500*	3250
7'10"	lb	—	—	<b>18,960</b>	<b>15,212</b>	<b>13,889</b>	<b>9921</b>	<b>10,141</b>	<b>7275</b>	<b>7716</b>	<b>7165</b>
2600 mm	kg	—	—	8650*	6900	6200*	4500	4650*	3300	3200*	3100
8'6"	lb	—	—	<b>19,070</b>	<b>15,212</b>	<b>13,669</b>	<b>9921</b>	<b>10,251</b>	<b>7275</b>	<b>7055</b>	<b>6834</b>

### M318F ● 4-Point Stabilizer Down

Stick		3 m 9'10"		4.5 m 15'0"		6 m 20'0"		7.5 m 25'0"		At Max. Reach	
		Front	Side	Front	Side	Front	Side	Front	Side	Front	Side
2100 mm	kg	—	—	8500*	8200	6250*	5300	—	—	4100*	4000
6'11"	lb	—	—	<b>18,739</b>	<b>18,078</b>	<b>13,779</b>	<b>11,684</b>	—	—	<b>9039</b>	<b>8818</b>
2400 mm	kg	—	—	8600*	8200	6300*	5300	4600*	3850	3500*	3500*
7'10"	lb	—	—	<b>18,960</b>	<b>18,078</b>	<b>13,889</b>	<b>11,684</b>	<b>10,141</b>	<b>8488</b>	<b>7716</b>	<b>7716</b>
2600 mm	kg	—	—	8650*	8200	6200*	5300	4650*	3850	3200*	3200*
8'6"	lb	—	—	<b>19,070</b>	<b>18,078</b>	<b>13,669</b>	<b>11,684</b>	<b>10,251</b>	<b>8488</b>	<b>7055</b>	<b>7055</b>

\*Indicates that the load is limited by hydraulic lifting capacity rather than tipping load.

**NOTE:** Oscillating axle needs to be locked. Weight of all lifting accessories must be subtracted from the lifting capacities.

All lift capacities calculated and rated per ISO 10567:2007. Rated loads do not exceed 87% of hydraulic lift capacity or 75% of tipping load.

Lifting capacities are based on the machine standing on a firm uniform supporting surface. The load point is the center line of the bucket pivot mounting pin on the stick.

# Hydraulic Excavators

## Lifting Capacity At Ground Level

- M318F ● Offset Boom
- 3400 kg (7496 lb) Counterweight

### M318F ● Rear Dozer Up

Stick		3 m 9'10"		4.5 m 15'0"		6 m 20'0"		7.5 m 25'0"		At Max. Reach	
		Rear	Side	Rear	Side	Rear	Side	Rear	Side	Rear	Side
2100 mm	kg	—	—	3700	3100	2500	2100	—	—	1900	1600
6'11"	lb	—	—	<b>8157</b>	<b>6834</b>	<b>5512</b>	<b>4630</b>	—	—	<b>4189</b>	<b>3527</b>
2400 mm	kg	—	—	3700	3100	2500	2100	1800	1550	1750	1500
7'10"	lb	—	—	<b>8157</b>	<b>6834</b>	<b>5512</b>	<b>4630</b>	<b>3968</b>	<b>3417</b>	<b>3858</b>	<b>3307</b>
2600 mm	kg	—	—	3700	3100	2500	2100	1800	1500	1700	1450
8'6"	lb	—	—	<b>8157</b>	<b>6834</b>	<b>5512</b>	<b>4630</b>	<b>3968</b>	<b>3307</b>	<b>3748</b>	<b>3197</b>

### M318F ● Rear Dozer Up

Stick		3 m 9'10"		4.5 m 15'0"		6 m 20'0"		7.5 m 25'0"		At Max. Reach	
		Front	Side	Front	Side	Front	Side	Front	Side	Front	Side
2100 mm	kg	—	—	5850	3100	3850	2100	—	—	2900	1600
6'11"	lb	—	—	<b>12,897</b>	<b>6834</b>	<b>8488</b>	<b>4630</b>	—	—	<b>6393</b>	<b>3527</b>
2400 mm	kg	—	—	5850	3100	3850	2100	2800	1550	2750	1500
7'10"	lb	—	—	<b>12,897</b>	<b>6834</b>	<b>8488</b>	<b>4630</b>	<b>6173</b>	<b>3417</b>	<b>6063</b>	<b>3307</b>
2600 mm	kg	—	—	5850	3100	3850	2100	2800	1500	2650	1450
8'6"	lb	—	—	<b>12,897</b>	<b>6834</b>	<b>8488</b>	<b>4630</b>	<b>6173</b>	<b>3307</b>	<b>5842</b>	<b>3197</b>

### M318F ● Rear Dozer Down

Stick		3 m 9'10"		4.5 m 15'0"		6 m 20'0"		7.5 m 25'0"		At Max. Reach	
		Rear	Side	Rear	Side	Rear	Side	Rear	Side	Rear	Side
2100 mm	kg	—	—	8150*	3700	5950*	2500	—	—	3600*	1900
6'11"	lb	—	—	<b>17,968</b>	<b>8157</b>	<b>13,118</b>	<b>5512</b>	—	—	<b>7937</b>	<b>4189</b>
2400 mm	kg	—	—	8250*	3700	6000*	2500	4400	1800	3100*	1800
7'10"	lb	—	—	<b>18,188</b>	<b>8157</b>	<b>13,228</b>	<b>5512</b>	<b>9700</b>	<b>3968</b>	<b>6834</b>	<b>3968</b>
2600 mm	kg	—	—	8300*	3700	6050*	2500	4350	1800	2800*	1700
8'6"	lb	—	—	<b>18,298</b>	<b>8157</b>	<b>13,338</b>	<b>5512</b>	<b>9590</b>	<b>3968</b>	<b>6173</b>	<b>3748</b>

### M318F ● Front Dozer and Rear Stabilizer Down

Stick		3 m 9'10"		4.5 m 15'0"		6 m 20'0"		7.5 m 25'0"		At Max. Reach	
		Rear	Side	Rear	Side	Rear	Side	Rear	Side	Rear	Side
2100 mm	kg	—	—	8150*	6200	5950*	4050	—	—	3600*	3050
6'11"	lb	—	—	<b>17,968</b>	<b>13,669</b>	<b>13,118</b>	<b>8929</b>	—	—	<b>7937</b>	<b>6724</b>
2400 mm	kg	—	—	8250*	6200	6000*	4050	4450*	2950	3100*	2900
7'10"	lb	—	—	<b>18,188</b>	<b>13,669</b>	<b>13,228</b>	<b>8929</b>	<b>9811</b>	<b>6504</b>	<b>6834</b>	<b>6393</b>
2600 mm	kg	—	—	8300*	6200	6050*	4050	4450	2950	2800*	2800
8'6"	lb	—	—	<b>18,298</b>	<b>13,669</b>	<b>13,338</b>	<b>8929</b>	<b>9811</b>	<b>6504</b>	<b>6173</b>	<b>6173</b>

### M318F ● 4-Point Stabilizer Down

Stick		3 m 9'10"		4.5 m 15'0"		6 m 20'0"		7.5 m 25'0"		At Max. Reach	
		Front	Side	Front	Side	Front	Side	Front	Side	Front	Side
2100 mm	kg	—	—	8150*	7450	5950*	4800	—	—	3600*	3600*
6'11"	lb	—	—	<b>17,968</b>	<b>16,424</b>	<b>13,118</b>	<b>10,582</b>	—	—	<b>7937</b>	<b>7937</b>
2400 mm	kg	—	—	8250*	7450	6000*	4800	4450*	3500	3100*	3100*
7'10"	lb	—	—	<b>18,188</b>	<b>16,424</b>	<b>13,228</b>	<b>10,582</b>	<b>9811</b>	<b>7716</b>	<b>6834</b>	<b>6834</b>
2600 mm	kg	—	—	8300*	7500	6050*	4800	4500*	3450	2800*	2800*
8'6"	lb	—	—	<b>18,298</b>	<b>16,535</b>	<b>13,338</b>	<b>10,582</b>	<b>9921</b>	<b>7606</b>	<b>6173</b>	<b>6173</b>

\*Indicates that the load is limited by hydraulic lifting capacity rather than tipping load.

**NOTE:** Oscillating axle needs to be locked. Weight of all lifting accessories must be subtracted from the lifting capacities.

All lift capacities calculated and rated per ISO 10567:2007. Rated loads do not exceed 87% of hydraulic lift capacity or 75% of tipping load.

Lifting capacities are based on the machine standing on a firm uniform supporting surface. The load point is the center line of the bucket pivot mounting pin on the stick.

Lifting Capacity At Ground Level  
 ● M318F ● Offset Boom  
 ● 3900 kg (8598 lb) Counterweight

**Hydraulic  
Excavators**

**M318F ● Rear Dozer Up**

Stick		3 m 9'10"		4.5 m 15'0"		6 m 20'0"		7.5 m 25'0"		At Max. Reach	
		Rear	Side	Rear	Side	Rear	Side	Rear	Side	Rear	Side
2100 mm	kg	—	—	4050	3400	2750	2300	—	—	2100	1750
6'11"	lb	—	—	<b>8929</b>	<b>7496</b>	<b>6063</b>	<b>5071</b>	—	—	<b>4630</b>	<b>3858</b>
2400 mm	kg	—	—	4050	3400	2700	2300	2000	1700	1950	1650
7'10"	lb	—	—	<b>8929</b>	<b>7496</b>	<b>5952</b>	<b>5071</b>	<b>4409</b>	<b>3748</b>	<b>4299</b>	<b>3638</b>
2600 mm	kg	—	—	4050	3400	2700	2300	2000	1700	1850	1600
8'6"	lb	—	—	<b>8929</b>	<b>7496</b>	<b>5952</b>	<b>5071</b>	<b>4409</b>	<b>3748</b>	<b>4079</b>	<b>3527</b>

**M318F ● Rear Dozer Up**

Stick		3 m 9'10"		4.5 m 15'0"		6 m 20'0"		7.5 m 25'0"		At Max. Reach	
		Front	Side	Front	Side	Front	Side	Front	Side	Front	Side
2100 mm	kg	—	—	6250	3400	4150	2300	—	—	3150	1750
6'11"	lb	—	—	<b>13,779</b>	<b>7496</b>	<b>9149</b>	<b>5071</b>	—	—	<b>6945</b>	<b>3858</b>
2400 mm	kg	—	—	6250	3400	4100	2300	3000	1700	2950	1650
7'10"	lb	—	—	<b>13,779</b>	<b>7496</b>	<b>9039</b>	<b>5071</b>	<b>6614</b>	<b>3748</b>	<b>6504</b>	<b>3638</b>
2600 mm	kg	—	—	6250	3400	4100	2300	3000	1700	2800*	1600
8'6"	lb	—	—	<b>13,779</b>	<b>7496</b>	<b>9039</b>	<b>5071</b>	<b>6614</b>	<b>3748</b>	<b>6173</b>	<b>3527</b>

**M318F ● Rear Dozer Down**

Stick		3 m 9'10"		4.5 m 15'0"		6 m 20'0"		7.5 m 25'0"		At Max. Reach	
		Rear	Side	Rear	Side	Rear	Side	Rear	Side	Rear	Side
2100 mm	kg	—	—	8150*	4050	5950*	2750	—	—	3600*	2100
6'11"	lb	—	—	<b>17,968</b>	<b>8929</b>	<b>13,118</b>	<b>6063</b>	—	—	<b>7937</b>	<b>4630</b>
2400 mm	kg	—	—	8250*	4000	6000*	2700	4450*	2000	3100*	1950
7'10"	lb	—	—	<b>18,188</b>	<b>8818</b>	<b>13,228</b>	<b>5952</b>	<b>9811</b>	<b>4409</b>	<b>6834</b>	<b>4299</b>
2600 mm	kg	—	—	—	4050	6050*	2700	4500*	2000	2800*	1900
8'6"	lb	—	—	—	<b>8929</b>	<b>13,338</b>	<b>5952</b>	<b>9921</b>	<b>4409</b>	<b>6173</b>	<b>4189</b>

**M318F ● Front Dozer and Rear Stabilizer Down**

Stick		3 m 9'10"		4.5 m 15'0"		6 m 20'0"		7.5 m 25'0"		At Max. Reach	
		Rear	Side	Rear	Side	Rear	Side	Rear	Side	Rear	Side
2100 mm	kg	—	—	8150*	6650	5950*	4350	—	—	3600*	3300
6'11"	lb	—	—	<b>17,968</b>	<b>14,661</b>	<b>13,118</b>	<b>9590</b>	—	—	<b>7937</b>	<b>7275</b>
2400 mm	kg	—	—	8250*	6600	6000*	4350	4450*	3150	3100*	3100*
7'10"	lb	—	—	<b>18,188</b>	<b>14,551</b>	<b>13,228</b>	<b>9590</b>	<b>9811</b>	<b>6945</b>	<b>6834</b>	<b>6834</b>
2600 mm	kg	—	—	8300*	6650	6050*	4350	4500*	3150	2800*	2800*
8'6"	lb	—	—	<b>18,298</b>	<b>14,661</b>	<b>13,338</b>	<b>9590</b>	<b>9921</b>	<b>6945</b>	<b>6173</b>	<b>6173</b>

**M318F ● 4-Point Stabilizer Down**

Stick		3 m 9'10"		4.5 m 15'0"		6 m 20'0"		7.5 m 25'0"		At Max. Reach	
		Front	Side	Front	Side	Front	Side	Front	Side	Front	Side
2100 mm	kg	—	—	8150*	7950	5950*	5150	—	—	3600*	3600*
6'11"	lb	—	—	<b>17,968</b>	<b>17,527</b>	<b>13,118</b>	<b>11,354</b>	—	—	<b>7937</b>	<b>7937</b>
2400 mm	kg	—	—	8250*	7950	6000*	5100	4450*	3700	3100*	3100*
7'10"	lb	—	—	<b>18,188</b>	<b>17,527</b>	<b>13,228</b>	<b>11,244</b>	<b>9811</b>	<b>8157</b>	<b>6834</b>	<b>6834</b>
2600 mm	kg	—	—	8300*	7950	6050*	5100	4500*	3700	2800*	2800*
8'6"	lb	—	—	<b>18,298</b>	<b>17,527</b>	<b>13,338</b>	<b>11,244</b>	<b>9921</b>	<b>8157</b>	<b>6173</b>	<b>6173</b>

\*Indicates that the load is limited by hydraulic lifting capacity rather than tipping load.

**NOTE:** Oscillating axle needs to be locked. Weight of all lifting accessories must be subtracted from the lifting capacities.

All lift capacities calculated and rated per ISO 10567:2007. Rated loads do not exceed 87% of hydraulic lift capacity or 75% of tipping load.

Lifting capacities are based on the machine standing on a firm uniform supporting surface. The load point is the center line of the bucket pivot mounting pin on the stick.



# Hydraulic Excavators

## Lifting Capacity At Ground Level

- M320F ● One-Piece Boom
- 3700 kg (8157 lb) Counterweight

### M320F ● Rear Dozer Up

Stick		3 m 9'10"		4.5 m 15'0"		6 m 20'0"		7.5 m 25'0"		At Max. Reach	
		Rear	Side	Rear	Side	Rear	Side	Rear	Side	Rear	Side
2200 mm 7'3"	kg lb	—	—	4450 9811	3800 8378	3000 6614	2600 5732	—	—	2250 4960	1950 4299
2500 mm 8'2"	kg lb	—	—	4500 9921	3800 8378	3000 6614	2600 5732	2200 4850	1900 4189	2100 4630	1850 4079
2800 mm 9'2"	kg lb	—	—	4500 9921	3800 8378	3000 6614	2600 5732	2200 4850	1900 4189	2000 4409	1700 3748

### M320F ● Rear Dozer Up

Stick		3 m 9'10"		4.5 m 15'0"		6 m 20'0"		7.5 m 25'0"		At Max. Reach	
		Front	Side	Front	Side	Front	Side	Front	Side	Front	Side
2200 mm 7'3"	kg lb	—	—	6700 14,771	3800 8378	4400 9700	2600 5732	—	—	3300 7275	1950 4299
2500 mm 8'2"	kg lb	—	—	6750 14,881	3800 8378	4400 9700	2600 5732	3250 7165	1900 4189	3100 6834	1850 4079
2800 mm 9'2"	kg lb	—	—	6750 14,881	3800 8378	4400 9700	2600 5732	3200 7055	1900 4189	2900 6393	1700 3748

### M320F ● Rear Dozer Down

Stick		3 m 9'10"		4.5 m 15'0"		6 m 20'0"		7.5 m 25'0"		At Max. Reach	
		Rear	Side	Rear	Side	Rear	Side	Rear	Side	Rear	Side
2200 mm 7'3"	kg lb	—	—	10 200* 22,487	4450 9811	6900 15,212	3000 6614	—	—	5000 11,023	2250 4960
2500 mm 8'2"	kg lb	—	—	10 250* 22,597	4450 9811	6950 15,322	3000 6614	4900 10,803	2200 4850	4100* 9039	2100 4630
2800 mm 9'2"	kg lb	—	—	10 200* 22,487	4450 9811	6950 15,322	3000 6614	4900 10,803	2200 4850	3500* 7716	2000 4409

### M320F ● Front Dozer and Rear Stabilizer Down

Stick		3 m 9'10"		4.5 m 15'0"		6 m 20'0"		7.5 m 25'0"		At Max. Reach	
		Rear	Side	Rear	Side	Rear	Side	Rear	Side	Rear	Side
2200 mm 7'3"	kg lb	—	—	10 200* 22,487	7100 15,653	6950 15,322	4650 10,251	—	—	5050 11,133	3450 7606
2500 mm 8'2"	kg lb	—	—	10 250* 22,597	7100 15,653	6950 15,322	4650 10,251	4950 10,913	3400 7496	4100* 9039	3250 7165
2800 mm 9'2"	kg lb	—	—	10 200* 22,487	7100 15,653	6950 15,322	4650 10,251	4950 10,913	3350 7385	3500* 7716	3050 6724

### M320F ● 4-Point Stabilizer Down

Stick		3 m 9'10"		4.5 m 15'0"		6 m 20'0"		7.5 m 25'0"		At Max. Reach	
		Front	Side	Front	Side	Front	Side	Front	Side	Front	Side
2200 mm 7'3"	kg lb	—	—	10 200* 22,487	8450 18,629	7450* 16,424	5450 12,015	—	—	5450* 12,015	4000 8818
2500 mm 8'2"	kg lb	—	—	10 250* 22,597	8450 18,629	7450* 16,424	5450 12,015	5750* 12,677	3950 8708	4100* 9039	3800 8378
2800 mm 9'2"	kg lb	—	—	10 200* 22,487	8450 18,629	7400* 16,314	5450 12,015	5750* 12,677	3900 8598	3500* 7716	3500* 7716

\*Indicates that the load is limited by hydraulic lifting capacity rather than tipping load.

**NOTE:** Oscillating axle needs to be locked. Weight of all lifting accessories must be subtracted from the lifting capacities.

All lift capacities calculated and rated per ISO 10567:2007. Rated loads do not exceed 87% of hydraulic lift capacity or 75% of tipping load.

Lifting capacities are based on the machine standing on a firm uniform supporting surface. The load point is the center line of the bucket pivot mounting pin on the stick.

Lifting Capacity At Ground Level  
 ● M320F ● One-Piece Boom  
 ● 4200 kg (9259 lb) Counterweight

**Hydraulic  
Excavators**

**M320F ● Rear Dozer Up**

Stick		3 m 9'10"		4.5 m 15'0"		6 m 20'0"		7.5 m 25'0"		At Max. Reach	
		Rear	Side	Rear	Side	Rear	Side	Rear	Side	Rear	Side
2200 mm	kg	—	—	4850	4150	3250	2850	—	—	2450	2150
7'3"	lb	—	—	10,692	9149	7165	6283	—	—	5401	4740
2500 mm	kg	—	—	4850	4150	3250	2850	2400	2100	2300	2000
8'2"	lb	—	—	10,692	9149	7165	6283	5291	4630	5071	4409
2800 mm	kg	—	—	4850	4150	3250	2800	2400	2050	2150	1900
9'2"	lb	—	—	10,692	9149	7165	6173	5291	4519	4740	4189

**M320F ● Rear Dozer Up**

Stick		3 m 9'10"		4.5 m 15'0"		6 m 20'0"		7.5 m 25'0"		At Max. Reach	
		Front	Side	Front	Side	Front	Side	Front	Side	Front	Side
2200 mm	kg	—	—	7150	4150	4750	2850	—	—	3550	2150
7'3"	lb	—	—	15,763	9149	10,472	6283	—	—	7826	4740
2500 mm	kg	—	—	7200	4150	4750	2850	3450	2100	3300	2000
8'2"	lb	—	—	15,873	9149	10,472	6283	7606	4630	7275	4409
2800 mm	kg	—	—	7200	4150	4700	2800	3450	2050	3150	1900
9'2"	lb	—	—	15,873	9149	10,362	6173	7606	4519	6945	4189

**M320F ● Rear Dozer Down**

Stick		3 m 9'10"		4.5 m 15'0"		6 m 20'0"		7.5 m 25'0"		At Max. Reach	
		Rear	Side	Rear	Side	Rear	Side	Rear	Side	Rear	Side
2200 mm	kg	—	—	10 200*	4800	7350	3250	—	—	5300	2450
7'3"	lb	—	—	22,487	10,582	16,204	7165	—	—	11,684	5401
2500 mm	kg	—	—	10 250*	4850	7350	3250	5200	2400	4100*	2300
8'2"	lb	—	—	22,597	10,692	16,204	7165	11,464	5291	9039	5071
2800 mm	kg	—	—	10 200*	4850	7350	3250	5200	2400	3500*	2200
9'2"	lb	—	—	22,487	10,692	16,204	7165	11,464	5291	7716	4850

**M320F ● Front Dozer and Rear Stabilizer Down**

Stick		3 m 9'10"		4.5 m 15'0"		6 m 20'0"		7.5 m 25'0"		At Max. Reach	
		Rear	Side	Rear	Side	Rear	Side	Rear	Side	Rear	Side
2200 mm	kg	—	—	10 200*	7550	7350	4950	—	—	5350	3700
7'3"	lb	—	—	22,487	16,645	16,204	10,913	—	—	11,795	8157
2500 mm	kg	—	—	10 250*	7600	7350	4950	5250	3600	4100*	3500
8'2"	lb	—	—	22,597	16,755	16,204	10,913	11,574	7937	9039	7716
2800 mm	kg	—	—	10 200*	7600	7350	4950	5250	3600	3500*	3300
9'2"	lb	—	—	22,487	16,755	16,204	10,913	11,574	7937	7716	7275

**M320F ● 4-Point Stabilizer Down**

Stick		3 m 9'10"		4.5 m 15'0"		6 m 20'0"		7.5 m 25'0"		At Max. Reach	
		Front	Side	Front	Side	Front	Side	Front	Side	Front	Side
2200 mm	kg	—	—	10 200*	8950	7450*	5750	—	—	5450*	4300
7'3"	lb	—	—	22,487	19,731	16,424	12,677	—	—	12,015	9480
2500 mm	kg	—	—	10 250*	8950	7450*	5750	5750*	4200	4100*	4000
8'2"	lb	—	—	22,597	19,731	16,424	12,677	12,677	9259	9039	8818
2800 mm	kg	—	—	10 200*	8950	7400*	5750	5750*	4150	3500*	3500*
9'2"	lb	—	—	22,487	19,731	16,314	12,677	12,677	9149	7716	7716

\*Indicates that the load is limited by hydraulic lifting capacity rather than tipping load.

**NOTE:** Oscillating axle needs to be locked. Weight of all lifting accessories must be subtracted from the lifting capacities.

All lift capacities calculated and rated per ISO 10567:2007. Rated loads do not exceed 87% of hydraulic lift capacity or 75% of tipping load.

Lifting capacities are based on the machine standing on a firm uniform supporting surface. The load point is the center line of the bucket pivot mounting pin on the stick.

# Hydraulic Excavators

## Lifting Capacity At Ground Level

- M320F ● Hydraulically Adjustable Boom
- 3700 kg (8157 lb) Counterweight

### M320F ● Rear Dozer Up

Stick		3 m 9'10"		4.5 m 15'0"		6 m 20'0"		7.5 m 25'0"		At Max. Reach	
		Rear	Side	Rear	Side	Rear	Side	Rear	Side	Rear	Side
2200 mm 7'3"	kg lb	—	—	4450 9811	3750 8267	3000 6614	2550 5622	—	—	2250 4960	1950 4299
2500 mm 8'2"	kg lb	—	—	4450 9811	3750 8267	3000 6614	2550 5622	2200 4850	1850 4079	2100 4630	1800 3968
2800 mm 9'2"	kg lb	—	—	4450 9811	3750 8267	3000 6614	2550 5622	2150 4740	1850 4079	2000 4409	1700 3748

### M320F ● Rear Dozer Up

Stick		3 m 9'10"		4.5 m 15'0"		6 m 20'0"		7.5 m 25'0"		At Max. Reach	
		Front	Side	Front	Side	Front	Side	Front	Side	Front	Side
2200 mm 7'3"	kg lb	—	—	6700 14,771	3750 8267	4400 9700	2550 5622	—	—	3300 7275	1950 4299
2500 mm 8'2"	kg lb	—	—	6750 14,881	3750 8267	4450 9811	2550 5622	3250 7165	1850 4079	3100 6834	1800 3968
2800 mm 9'2"	kg lb	—	—	6750 14,881	3750 8267	4400 9700	2550 5622	3200 7055	1850 4079	2950 6504	1700 3748

### M320F ● Rear Dozer Down

Stick		3 m 9'10"		4.5 m 15'0"		6 m 20'0"		7.5 m 25'0"		At Max. Reach	
		Rear	Side	Rear	Side	Rear	Side	Rear	Side	Rear	Side
2200 mm 7'3"	kg lb	—	—	10 050* 22,156	4400 9700	7000 15,432	3000 6614	—	—	5000* 11,023	2250 4960
2500 mm 8'2"	kg lb	—	—	10 100* 22,267	4450 9811	7000 15,432	3000 6614	4950 10,913	2200 4850	3700* 8157	2100 4630
2800 mm 9'2"	kg lb	—	—	10 100* 22,267	4450 9811	7000 15,432	3000 6614	4900 10,803	2150 4740	3200* 7055	2000 4409

### M320F ● Front Dozer and Rear Stabilizer Down

Stick		3 m 9'10"		4.5 m 15'0"		6 m 20'0"		7.5 m 25'0"		At Max. Reach	
		Rear	Side	Rear	Side	Rear	Side	Rear	Side	Rear	Side
2200 mm 7'3"	kg lb	—	—	10 050* 22,156	7100 15,653	7000 15,432	4650 10,251	—	—	5000* 11,023	3500 7716
2500 mm 8'2"	kg lb	—	—	10 100* 22,267	7100 15,653	7000 15,432	4650 10,251	5000 11,023	3400 7496	3700* 8157	3250 7165
2800 mm 9'2"	kg lb	—	—	10 100* 22,267	7150 15,763	7000 15,432	4650 10,251	5000 11,023	3350 7385	3200* 7055	3100 6834

### M320F ● 4-Point Stabilizer Down

Stick		3 m 9'10"		4.5 m 15'0"		6 m 20'0"		7.5 m 25'0"		At Max. Reach	
		Front	Side	Front	Side	Front	Side	Front	Side	Front	Side
2200 mm 7'3"	kg lb	—	—	10 050* 22,156	8450 18,629	7350* 16,204	5450 12,015	—	—	5000* 11,023	4050 8929
2500 mm 8'2"	kg lb	—	—	10 100* 22,267	8500 18,739	7350* 16,204	5450 12,015	5600* 12,346	3950 8708	3700* 8157	3700* 8157
2800 mm 9'2"	kg lb	—	—	10 100* 22,267	8500 18,739	7350* 16,204	5450 12,015	5650* 12,456	3950 8708	3200* 7055	3200* 7055

\*Indicates that the load is limited by hydraulic lifting capacity rather than tipping load.

**NOTE:** Oscillating axle needs to be locked. Weight of all lifting accessories must be subtracted from the lifting capacities.

All lift capacities calculated and rated per ISO 10567:2007. Rated loads do not exceed 87% of hydraulic lift capacity or 75% of tipping load.

Lifting capacities are based on the machine standing on a firm uniform supporting surface. The load point is the center line of the bucket pivot mounting pin on the stick.

- M320F ● Hydraulically Adjustable Boom
- 4200 kg (9259 lb) Counterweight

## Hydraulic Excavators

### M320F ● Rear Dozer Up

Stick		3 m 9'10"		4.5 m 15'0"		6 m 20'0"		7.5 m 25'0"		At Max. Reach	
		Rear	Side	Rear	Side	Rear	Side	Rear	Side	Rear	Side
2200 mm	kg	—	—	4800	4100	3250	2800	—	—	2450	2100
7'3"	lb	—	—	10,582	9039	7165	6173	—	—	5401	4630
2500 mm	kg	—	—	4850	4100	3250	2800	2400	2050	2300	2000
8'2"	lb	—	—	10,692	9039	7165	6173	5291	4519	5071	4409
2800 mm	kg	—	—	4850	4100	3250	2800	2350	2050	2150	1850
9'2"	lb	—	—	10,692	9039	7165	6173	5181	4519	4740	4079

### M320F ● Rear Dozer Up

Stick		3 m 9'10"		4.5 m 15'0"		6 m 20'0"		7.5 m 25'0"		At Max. Reach	
		Front	Side	Front	Side	Front	Side	Front	Side	Front	Side
2200 mm	kg	—	—	7150	4100	4750	2800	—	—	3550	2100
7'3"	lb	—	—	15,763	9039	10,472	6173	—	—	7826	4630
2500 mm	kg	—	—	7200	4100	4750	2800	3450	2050	3350	2000
8'2"	lb	—	—	15,873	9039	10,472	6173	7606	4519	7385	4409
2800 mm	kg	—	—	7200	4100	4750	2800	3450	2050	3150	1850
9'2"	lb	—	—	15,873	9039	10,472	6173	7606	4519	6945	4079

### M320F ● Rear Dozer Down

Stick		3 m 9'10"		4.5 m 15'0"		6 m 20'0"		7.5 m 25'0"		At Max. Reach	
		Rear	Side	Rear	Side	Rear	Side	Rear	Side	Rear	Side
2200 mm	kg	—	—	10 050*	4800	7350*	3250	—	—	5000*	2450
7'3"	lb	—	—	22,156	10,582	16,204	7165	—	—	11,023	5401
2500 mm	kg	—	—	10 100*	4800	7350*	3250	5250	2400	3700*	2300
8'2"	lb	—	—	22,267	10,582	16,204	7165	11,574	5291	8157	5071
2800 mm	kg	—	—	10 100*	4800	7350*	3250	5200	2350	3200*	2150
9'2"	lb	—	—	22,267	10,582	16,204	7165	11,464	5181	7055	4740

### M320F ● Front Dozer and Rear Stabilizer Down

Stick		3 m 9'10"		4.5 m 15'0"		6 m 20'0"		7.5 m 25'0"		At Max. Reach	
		Rear	Side	Rear	Side	Rear	Side	Rear	Side	Rear	Side
2200 mm	kg	—	—	10 050*	7550	7350*	4950	—	—	5000*	3700
7'3"	lb	—	—	22,156	16,645	16,204	10,913	—	—	11,023	8157
2500 mm	kg	—	—	10 100*	7600	7350*	4950	5300	3600	3700*	3500
8'2"	lb	—	—	22,267	16,755	16,204	10,913	11,684	7937	8157	7716
2800 mm	kg	—	—	10 100*	7600	7350*	4950	5250	3600	3200*	3200*
9'2"	lb	—	—	22,267	16,755	16,204	10,913	11,574	7937	7055	7055

### M320F ● 4-Point Stabilizer Down

Stick		3 m 9'10"		4.5 m 15'0"		6 m 20'0"		7.5 m 25'0"		At Max. Reach	
		Front	Side	Front	Side	Front	Side	Front	Side	Front	Side
2200 mm	kg	—	—	10 050*	9000	7350*	5800	—	—	5000*	4300
7'3"	lb	—	—	22,156	19,842	16,204	12,787	—	—	11,023	9480
2500 mm	kg	—	—	10 100*	9000	7350*	5800	5600*	4200	3700*	3700*
8'2"	lb	—	—	22,267	19,842	16,204	12,787	12,346	9259	8157	8157
2800 mm	kg	—	—	10 100*	9000	7350*	5800	5650*	4200	3200*	3200*
9'2"	lb	—	—	22,267	19,842	16,204	12,787	12,456	9259	7055	7055

\*Indicates that the load is limited by hydraulic lifting capacity rather than tipping load.

NOTE: Oscillating axle needs to be locked. Weight of all lifting accessories must be subtracted from the lifting capacities.

All lift capacities calculated and rated per ISO 10567:2007. Rated loads do not exceed 87% of hydraulic lift capacity or 75% of tipping load.

Lifting capacities are based on the machine standing on a firm uniform supporting surface. The load point is the center line of the bucket pivot mounting pin on the stick.

**Asia Pacific, China, Latin America**

**320D2 ● Reach Boom ● 600 mm (24") Track Shoes**

Stick	Bucket		3 m 9'10"		4.5 m 15'0"		6 m 20'0"		7.5 m 25'0"		9 m 30'0"		At Max. Reach	
			Front	Side	Front	Side	Front	Side	Front	Side	Front	Side	Front	Side
2500 mm	0.9 m <sup>3</sup>	kg	5850*	5850*	8800	5350	5600	3500	3950	2500	—	—	3050*	1900
8'2"	1.18 yd <sup>3</sup>	lb	13,450*	13,450	18,850	11,450	11,950	7500	8450	5300	—	—	6700*	4150
2900 mm	0.8 m <sup>3</sup>	kg	6600*	6600*	8900	5400	5600	3550	3950	2500	—	—	2650*	1800
9'6"	1.05 yd <sup>3</sup>	lb	15,050*	15,050*	19,050	11,600	12,050	7600	8500	5350	—	—	5750*	3900

**Africa, Middle East, CIS Asia Pacific, China, Latin America**

**320D2 GC ● 600 mm (24") Track Shoes ● Reach Boom ● No Bucket**

Stick			3 m 9'10"		4.5 m 15'0"		6 m 20'0"		7.5 m 25'0"		9 m 30'0"		At Max. Reach	
			Front	Side	Front	Side	Front	Side	Front	Side	Front	Side	Front	Side
2900 mm		kg	6200*	6200*	8900	5550	5800	3750	4150	2750	—	—	3700	2450
9'6"		lb	14,300*	14,300*	19,150	11,950	12,400	8050	9000	5900	—	—	8100	5350

**320D2 GC ● 790 mm (31") Track Shoes ● Reach Boom ● No Bucket**

Stick			3 m 9'10"		4.5 m 15'0"		6 m 20'0"		7.5 m 25'0"		9 m 30'0"		At Max. Reach	
			Front	Side	Front	Side	Front	Side	Front	Side	Front	Side	Front	Side
2900 mm		kg	6200*	6200*	9200	5700	5950	3850	4350	2850	—	—	3800	2500
9'6"		lb	14,300*	14,300*	19,700	12,300	12,800	8350	9300	6150	—	—	8350	5500

**Africa, Middle East, CIS, Asia Pacific, China, Latin America**

**320D2 L ● Reach Boom ● 600 mm (24") Track Shoes**

Stick	Bucket		3 m 9'10"		4.5 m 15'0"		6 m 20'0"		7.5 m 25'0"		9 m 30'0"		At Max. Reach	
			Front	Side	Front	Side	Front	Side	Front	Side	Front	Side	Front	Side
2500 mm	0.9 m <sup>3</sup>	kg	—	—	10,700*	6700	7350	4500	5300	3300	—	—	5000	3100
8'2"	1.2 yd <sup>3</sup>	lb	—	—	23,150*	14,350	15,800	9650	11,450	7150	—	—	10,950	6850
2900 mm	0.9 m <sup>3</sup>	kg	6350*	6350*	10,550	6700	7400	4500	5300	3300	—	—	4350*	2900
9'6"	1.2 yd <sup>3</sup>	lb	14,600*	14,600*	22,850*	14,450	15,850	9700	11,400	7100	—	—	9550*	6350

**320D2 L ● Reach Boom ● 790 mm (31") Track Shoes**

Stick	Bucket		3 m 9'10"		4.5 m 15'0"		6 m 20'0"		7.5 m 25'0"		9 m 30'0"		At Max. Reach	
			Front	Side	Front	Side	Front	Side	Front	Side	Front	Side	Front	Side
2500 mm	B1-1280X	kg	—	—	10,700*	6850	7550	4600	5450	3400	—	—	5100	3200
8'2"	4'2"	lb	—	—	23,150*	14,800	16,250	9950	11,750	7350	—	—	11,250	7050
2900 mm	B1-1220X	kg	6350*	6350*	10,550	6900	7600	4650	5450	3400	—	—	4350*	3000
9'6"	4'0"	lb	14,600*	14,600*	22,850*	14,850	16,300	9950	11,750	7300	—	—	9550*	6550

\*Load limited by hydraulic capacity rather than tipping.

**North America**

**320E LRR ● 790 mm (31") Track Shoes ● HD Boom ● No Bucket  
 ● Heavy Lift Mode On ● 6.9 mt Counterweight**

Stick		3 m 9'10"		4.5 m 15'0"		6 m 20'0"		7.5 m 25'0"		9 m 30'0"		At Max. Reach	
		Front	Side	Front	Side	Front	Side	Front	Side	Front	Side	Front	Side
2.9 m	kg	6600*	6600*	11 650	7950	8500*	5350	6250	4000	—	—	4650*	3500
9'6"	lb	15,150	15,150	25,200	17,100	18,400	11,550	13,450	8550	—	—	10,250	7700

**North America, Europe, Australia, New Zealand**

**320F L ● Reach Boom ● 790 mm (31") Track Shoes  
 ● Heavy Lift Mode On ● No Bucket**

Stick		3 m 9'10"		4.5 m 15'0"		6 m 20'0"		7.5 m 25'0"		9 m 30'0"		At Max. Reach	
		Front	Side	Front	Side	Front	Side	Front	Side	Front	Side	Front	Side
2.9 m	kg	6600*	6600*	11 500*	6800	7400	4550	5350	3400	—	—	4650	2950
9'6"	lb	15,150*	15,150*	24,900*	14,600	15,900	9850	11,500	7250	—	—	10,250	6500

**320F L ● Reach Boom ● 600 mm (24") Track Shoes  
 ● Heavy Lift Mode On ● No Bucket**

Stick		3 m 9'10"		4.5 m 15'0"		6 m 20'0"		7.5 m 25'0"		9 m 30'0"		At Max. Reach	
		Front	Side	Front	Side	Front	Side	Front	Side	Front	Side	Front	Side
2920 mm	kg	6600*	6600*	11 350	6600	7200	4450	5200	3300	—	—	4550	2900
9'6"	lb	15,150*	15,150*	24,300	14,200	15,450	9550	11,150	7050	—	—	9950	6300

**320F L ● VA Boom ● 600 mm (24") Track Shoes  
 ● Heavy Lift Mode On ● No Bucket**

Stick		3 m 9'10"		4.5 m 15'0"		6 m 20'0"		7.5 m 25'0"		9 m 30'0"		At Max. Reach	
		Front	Side	Front	Side	Front	Side	Front	Side	Front	Side	Front	Side
2920 mm	kg	6000*	6000*	9950*	6100	6850*	4100	5000	3050	—	—	4150	2500
9'6"	lb	12,950*	12,950*	21,350*	13,150	14,800*	8850	10,800	6500	—	—	9100	5500

**Africa, Middle East, China, Latin America**

**323D2 L ● Reach Boom ● 600 mm (24") Track Shoes**

Stick		3 m 9'10"		4.5 m 15'0"		6 m 20'0"		7.5 m 25'0"		9 m 30'0"		At Max. Reach	
		Front	Side	Front	Side	Front	Side	Front	Side	Front	Side	Front	Side
2.5 m	kg	—	—	10 700	6700	7350	4500	5300	3300	—	—	5000	3100
8'2"	lb	—	—	23,150	14,350	15,800	9650	11,450	7150	—	—	10,950	6850
2.9 m	kg	6350	6350	10 550	6700	7400	4500	5300	3300	—	—	4350	2900
9'6"	lb	14,600	14,600	22,850	14,450	15,850	9700	11,400	9100	—	—	9550	6350

\*Load limited by hydraulic capacity rather than tipping.

**North America, Europe, Australia, New Zealand**

**323F L ● 790 mm (31") Track Shoes ● Reach Boom ● No Bucket**  
● Heavy Lift Mode On ● 4.1 mt Counterweight

Stick		3 m 9'10"		4.5 m 15'0"		6 m 20'0"		7.5 m 25'0"		9 m 30'0"		At Max. Reach	
		Front	Side	Front	Side	Front	Side	Front	Side	Front	Side	Front	Side
2900 mm	kg	6600*	6600*	11 650*	7550	8050	5050	5850	3750	—	—	4650*	3300
9'6"	lb	15,150*	15,150*	25,250*	16,250	17,350	10,900	12,550	8100	—	—	10,250*	7250

**323F L ● 600 mm (24") Track Shoes ● Reach Boom ● No Bucket**  
● Heavy Lift Mode On ● 4.1 mt Counterweight

Stick		3 m 9'10"		4.5 m 15'0"		6 m 20'0"		7.5 m 25'0"		9 m 30'0"		At Max. Reach	
		Front	Side	Front	Side	Front	Side	Front	Side	Front	Side	Front	Side
2920 mm	kg	6600*	6600*	11 500*	7250	7800	4900	5650	3600	—	—	4650*	3200
9'6"	lb	15,150*	15,150*	24,900*	15,650	16,800	10,550	12,150	7800	—	—	10,250*	7000

**323F L ● 790 mm (31") Track Shoes ● Heavy Lift Reach Boom ● No Bucket**  
● Heavy Lift Mode On ● 5.4 mt Counterweight

Stick		3 m 9'10"		4.5 m 15'0"		6 m 20'0"		7.5 m 25'0"		9 m 30'0"		At Max. Reach	
		Front	Side	Front	Side	Front	Side	Front	Side	Front	Side	Front	Side
2920 mm	kg	6600*	6600*	12 800*	8800	9250	5950	6700	4400	—	—	4650*	3900
9'6"	lb	15,150*	15,150*	27,700*	18,950	19,900	12,800	14,450	9500	—	—	10,250*	8550

**323F L ● 600 mm (24") Track Shoes ● Reach Boom ● No Bucket**  
● Heavy Lift Mode On ● 5.4 mt Counterweight

Stick		3 m 9'10"		4.5 m 15'0"		6 m 20'0"		7.5 m 25'0"		9 m 30'0"		At Max. Reach	
		Front	Side	Front	Side	Front	Side	Front	Side	Front	Side	Front	Side
2920 mm	kg	6600*	6600*	11 500*	8450	8400*	5700	6450	4250	—	—	4650*	3750
9'6"	lb	15,150*	15,150*	24,900*	18,150	18,200*	12,250	13,850	9100	—	—	10,250*	8200

**323F L ● 600 mm (24") Track Shoes ● VA Boom ● No Bucket**  
● Heavy Lift Mode On ● 5.4 mt Counterweight

Stick		3 m 9'10"		4.5 m 15'0"		6 m 20'0"		7.5 m 25'0"		9 m 30'0"		At Max. Reach	
		Front	Side	Front	Side	Front	Side	Front	Side	Front	Side	Front	Side
2920 mm	kg	6000*	6000*	9950*	7950	6850*	5350	5900*	4000	—	—	4900*	3300
9'6"	lb	12,950*	12,950*	21,350*	17,100	14,800*	11,550	13,200*	8600	—	—	10,750*	7300

**323F LN ● 500 mm (20") Track Shoes ● Reach Boom**  
● No Bucket ● Heavy Lift Mode On

Stick		3 m 9'10"		4.5 m 15'0"		6 m 20'0"		7.5 m 25'0"		9 m 30'0"		At Max. Reach	
		Front	Side	Front	Side	Front	Side	Front	Side	Front	Side	Front	Side
2920 mm	kg	6600*	6600*	11 500*	6150	7950	4200	5750	3150	—	—	4650*	2750
9'6"	lb	15,150*	15,150*	24,900*	13,200	17,050	9050	12,350	6750	—	—	10,250*	6050

**323F LN ● 500 mm (20") Track Shoes ● VA Boom**  
● No Bucket ● Heavy Lift Mode On

Stick		3 m 9'10"		4.5 m 15'0"		6 m 20'0"		7.5 m 25'0"		9 m 30'0"		At Max. Reach	
		Front	Side	Front	Side	Front	Side	Front	Side	Front	Side	Front	Side
2920 mm	kg	5700*	5700*	8350*	5600	5750*	3850	5500*	2850	—	—	4500*	2400
9'6"	lb	12,200*	12,200*	17,950*	12,100	12,450*	8300	11,950	6150	—	—	9850*	5250

\*Load limited by hydraulic capacity rather than tipping.

**North America, Europe, Australia, New Zealand**

**325F L ● 790 mm (31") Track Shoes ● 5.7 m (18'8") Reach Boom ● No Bucket  
 ● Heavy Lift Mode On ● Standard Counterweight**

Stick		1.5 m 5'0"		3 m 9'10"		4.5 m 15'0"		6 m 20'0"		7.5 m 25'0"		At Max. Reach	
		Front	Side	Front	Side	Front	Side	Front	Side	Front	Side	Front	Side
2920 mm	kg	—	—	7350*	7350*	12 650	7100	8000	4800	5800	3550	4750*	3150
9'6"	lb	—	—	16,800*	16,800*	27,100	15,350	17,250	10,300	12,500	7650	10,450*	6950

**325F L ● 600 mm (24") Track Shoes ● 5.7 m (18'8") Reach Boom ● No Bucket  
 ● Heavy Lift Mode On ● Standard Counterweight**

Stick		1.5 m 5'0"		3 m 9'10"		4.5 m 15'0"		6 m 20'0"		7.5 m 25'0"		At Max. Reach	
		Front	Side	Front	Side	Front	Side	Front	Side	Front	Side	Front	Side
2920 mm	kg	—	—	7350*	7350*	12 350	6950	7850	4700	5650	3450	4750*	3100
9'6"	lb	—	—	16,800*	16,800*	26,500	14,950	16,850	10,050	12,200	7450	10,450*	6800

**Europe**

**325F L ● 600 mm (24") Track Shoes ● VA Boom (2.8 m [9'2"] Stub + 3.3 m [10'10"] Fore)  
 ● No Bucket ● Heavy Lift Mode On ● Standard Counterweight**

Stick		1.5 m 5'0"		3 m 9'10"		4.5 m 15'0"		6 m 20'0"		7.5 m 25'0"		At Max. Reach	
		Front	Side	Front	Side	Front	Side	Front	Side	Front	Side	Front	Side
2920 mm	kg	7150*	7150*	6000*	6000*	10 400*	6700	4500	4700	5600	3350	4700	2800
9'6"	lb	15,350*	15,350*	13,000*	13,000*	22,350*	14,450	9700	10,050	12,050	7200	10,300	6200

**Asia Pacific**

**326D2 L ● Reach Boom ● 600 mm (24") Track Shoes ● No Bucket**

Stick		3 m 9'10"		4.5 m 15'0"		6 m 20'0"		7.5 m 25'0"		9 m 30'0"		At Max. Reach	
		Front	Side	Front	Side	Front	Side	Front	Side	Front	Side	Front	Side
2500 mm	kg	—	—	14 200*	8950	9250	5950	6700	4400	—	—	6100	4050
8'2"	lb	—	—	30,750*	19,200	19,950	12,800	14,400	9500	—	—	13,450	8900
2950 mm	kg	—	—	14 100*	8950	9300	5950	6650	4400	—	—	5650	3750
9'8"	lb	—	—	30,450*	19,250	19,950	12,800	14,350	9450	—	—	12,450	8250

\*Load limited by hydraulic capacity rather than tipping.



**North America, Europe, Japan**

**326F L ● 790 mm (31") Track Shoes ● 5.9 m Reach Boom ● No Bucket**  
● Heavy Lift Mode On ● 4.0 mt Counterweight

Stick		1.5 m 5'0"		3 m 9'10"		4.5 m 15'0"		6 m 20'0"		7.5 m 25'0"		At Max. Reach	
		Front	Side	Front	Side	Front	Side	Front	Side	Front	Side	Front	Side
2500 mm	kg	—	—	—	—	15 300	9200	9600	6150	6950	4550	6300	4200
8'2"	lb	—	—	—	—	<b>32,850</b>	<b>19,800</b>	<b>20,650</b>	<b>13,250</b>	<b>14,900</b>	<b>9800</b>	<b>13,900</b>	<b>9200</b>
2950 mm	kg	—	—	—	—	15 350	9250	9600	6150	6900	4500	5850	3850
9'8"	lb	—	—	—	—	<b>32,900</b>	<b>19,850</b>	<b>20,650</b>	<b>13,200</b>	<b>14,850</b>	<b>9750</b>	<b>12,850</b>	<b>8350</b>

**Europe**

**326F L ● 790 mm (31") Track Shoes ● VA Boom ● No Bucket**  
● Heavy Lift Mode On ● 4.0 mt Counterweight

Stick		1.5 m 5'0"		3 m 9'10"		4.5 m 15'0"		6 m 20'0"		7.5 m 25'0"		At Max. Reach	
		Front	Side	Front	Side	Front	Side	Front	Side	Front	Side	Front	Side
2500 mm	kg	—	—	9450*	9450*	14 950	8800	9400	5850	6750	4350	5950	3850
8'2"	lb	—	—	<b>20,850*</b>	<b>20,850*</b>	<b>32,050</b>	<b>18,900</b>	<b>20,150</b>	<b>12,600</b>	<b>14,550</b>	<b>9350</b>	<b>13,100</b>	<b>8450</b>
2950 mm	kg	7900*	7900*	6450*	6450*	14 300*	8800	9400	5850	6750	4300	5500	3550
9'8"	lb	<b>17,350*</b>	<b>17,350*</b>	<b>14,300*</b>	<b>14,300*</b>	<b>30,600*</b>	<b>18,950</b>	<b>20,200</b>	<b>12,600</b>	<b>14,500</b>	<b>9250</b>	<b>12,100</b>	<b>7800</b>

**326F LN ● 600 mm (24") Track Shoes ● 5.9 m Reach Boom ● No Bucket**  
● Heavy Lift Mode On ● 4.0 mt Counterweight

Stick		1.5 m 5'0"		3 m 9'10"		4.5 m 15'0"		6 m 20'0"		7.5 m 25'0"		At Max. Reach	
		Front	Side	Front	Side	Front	Side	Front	Side	Front	Side	Front	Side
2500 mm	kg	—	—	—	—	14 800	8050	9250	5400	6700	4000	6100	3700
8'2"	lb	—	—	—	—	<b>31,700</b>	<b>17,300</b>	<b>19,950</b>	<b>11,650</b>	<b>14,400</b>	<b>8650</b>	<b>13,400</b>	<b>8100</b>
2950 mm	kg	—	—	—	—	14 800	8050	9300	5400	6650	4000	5650	3400
9'8"	lb	—	—	—	—	<b>31,750</b>	<b>17,350</b>	<b>19,950</b>	<b>11,650</b>	<b>14,350</b>	<b>8600</b>	<b>12,450</b>	<b>7500</b>

**326F LN ● 600 mm (24") Track Shoes ● VA Boom ● No Bucket**  
● Heavy Lift Mode On ● 4.0 mt Counterweight

Stick		1.5 m 5'0"		3 m 9'10"		4.5 m 15'0"		6 m 20'0"		7.5 m 25'0"		At Max. Reach	
		Front	Side	Front	Side	Front	Side	Front	Side	Front	Side	Front	Side
2500 mm	kg	—	—	9450*	9450*	14 550	7700	9150	5200	6600	3850	5800	3400
8'2"	lb	—	—	<b>20,850*</b>	<b>20,850*</b>	<b>31,200</b>	<b>16,550</b>	<b>19,650</b>	<b>11,150</b>	<b>14,150</b>	<b>8250</b>	<b>12,750</b>	<b>7500</b>
2950 mm	kg	7900*	7900*	6450*	6450*	14 300*	7700	9150	5150	6550	3800	5350	3150
9'8"	lb	<b>17,350*</b>	<b>17,350*</b>	<b>14,300*</b>	<b>14,300*</b>	<b>30,600*</b>	<b>16,650</b>	<b>19,600</b>	<b>11,100</b>	<b>14,100</b>	<b>8200</b>	<b>11,750</b>	<b>6850</b>

\*Load limited by hydraulic capacity rather than tipping.

**South America**

**330D2 L ● Reach Boom ● 800 mm (32") Track Shoes ● No Bucket**

Stick	3 m 9'10"		4.5 m 15'0"		6 m 20'0"		7.5 m 25'0"		9 m 30'0"		At Max. Reach		
	Front	Side	Front	Side	Front	Side	Front	Side	Front	Side	Front	Side	
3200 mm 10'6"	kg			16 500*	10 550	11 350	7000	8150	5150			5850*	4050
	lb	—	—	35,700*	22,650	24,450	15,100	17,500	11,100	—	—	12,800*	8850

**330D2 L ● Mass Boom ● 800 mm (32") Track Shoes ● No Bucket**

Stick	3 m 9'10"		4.5 m 15'0"		6 m 20'0"		7.5 m 25'0"		9 m 30'0"		At Max. Reach		
	Front	Side	Front	Side	Front	Side	Front	Side	Front	Side	Front	Side	
2500 mm 8'2"	kg			16 700*	10 600	11 450	7050	8200	5200			7950	5050
	lb	—	—	36,150*	22,800	24,550	15,150	17,600	11,150	—	—	17,550	11,150

**Middle East, Africa**

**330D2 L ● Reach Boom ● 800 mm (32") Track Shoes ● No Bucket**

Stick	3 m 9'10"		4.5 m 15'0"		6 m 20'0"		7.5 m 25'0"		9 m 30'0"		At Max. Reach		
	Front	Side	Front	Side	Front	Side	Front	Side	Front	Side	Front	Side	
2650 mm 8'8"	kg			16 600*	10 650	11 450	7100	8200	5250			6850	4450
	lb	—	—	36,450*	22,900	24,600	15,250	17,700	11,300	—	—	15,150	9750
3200 mm 10'6"	kg			16 500*	10 550	11 350	7000	8150	5150			5850*	4050
	lb	—	—	35,700*	22,650	24,450	15,100	17,500	11,100	—	—	12,800*	8850

**330D2 L ● Mass Boom ● 800 mm (32") Track Shoes ● No Bucket**

Stick	3 m 9'10"		4.5 m 15'0"		6 m 20'0"		7.5 m 25'0"		9 m 30'0"		At Max. Reach		
	Front	Side	Front	Side	Front	Side	Front	Side	Front	Side	Front	Side	
2500 mm 8'2"	kg			16 700*	10 600	11 450	7050	8200	5200			7950	5050
	lb	—	—	36,150*	22,800	24,550	15,150	17,600	11,150	—	—	17,550	11,150

**North America, Europe, Japan**

**330F L ● 800 mm (32") Track Shoes ● 6.15 m Reach Boom ● No Bucket  
● Heavy Lift Mode On ● 5.8 mt Counterweight**

Stick	3 m 9'10"		4.5 m 15'0"		6 m 20'0"		7.5 m 25'0"		9 m 30'0"		At Max. Reach		
	Front	Side	Front	Side	Front	Side	Front	Side	Front	Side	Front	Side	
2650 mm 8'8"	kg			17 550*								7250	4700
	lb	—	—	40,150*	24,200	25,950	16,150	18,650	11,950	—	—	15,950	10,350
3200 mm 10'6"	kg			18 200*	11 150	12 000	7400	8600	5450			6400*	4300
	lb	—	—	39,400*	23,950	25,750	15,950	18,450	11,750	—	—	14,050*	9400
3750 mm 12'4"	kg	6500*	6500*	17 650*	11 050	11 900	7350	8500	5400	6500	4150	5350*	3850
	lb	14,900*	14,900*	38,150*	23,750	25,600	15,800	18,300	11,550	14,000	8950	11,800*	8500

\*Load limited by hydraulic capacity rather than tipping.

**Europe**

**330F L ● 600 mm (24") Track Shoes ● 6.15 m Reach Boom ● No Bucket**  
**● Heavy Lift Mode On ● 5.8 mt Counterweight**

Stick		3 m 9'10"		4.5 m 15'0"		6 m 20'0"		7.5 m 25'0"		9 m 30'0"		At Max. Reach	
		Front	Side	Front	Side	Front	Side	Front	Side	Front	Side	Front	Side
2650 mm	kg	—	—	17 550*	10 900	11 700	7300	8400	5400	—	—	7050	4550
8'8"	lb	—	—	40,150*	23,500	25,150	15,700	18,100	11,600	—	—	15,500	10,050
3200 mm	kg	—	—	18 200*	10 800	11 650	7200	8350	5300	—	—	6400*	4150
10'6"	lb	—	—	39,400*	23,250	25,000	15,500	17,900	11,400	—	—	14,050*	9100

**330F LN ● 600 mm (24") Track Shoes ● 6.15 m Reach Boom ● No Bucket**  
**● Heavy Lift Mode On ● 5.8 mt Counterweight**

Stick		3 m 9'10"		4.5 m 15'0"		6 m 20'0"		7.5 m 25'0"		9 m 30'0"		At Max. Reach	
		Front	Side	Front	Side	Front	Side	Front	Side	Front	Side	Front	Side
2650 mm	kg	—	—	17 550*	9950	11 650	6700	8350	4950	—	—	7000	4200
8'8"	lb	—	—	40,150*	21,350	25,050	14,400	18,000	10,700	—	—	15,400	9250
3200 mm	kg	—	—	18 200*	9800	11 600	6600	8300	4900	—	—	6400*	3800
10'6"	lb	—	—	39,400*	21,100	24,900	14,200	17,850	10,500	—	—	14,050*	8400

**North America**

**335F L ● Reach Boom ● 850 mm (33") Track Shoes ● Heavy Lift Mode On ● No Bucket**

Stick		3 m 9'10"		4.5 m 15'0"		6 m 20'0"		7.5 m 25'0"		9 m 30'0"		At Max. Reach	
		Front	Side	Front	Side	Front	Side	Front	Side	Front	Side	Front	Side
3200 mm	kg	6050*	6050*	17 300*	11 050*	12 700*	7350	9200	5400	—	—	6500*	4250
10'6"	lb	13,900*	13,900*	37,500*	23,750*	27,500*	15,800	19,800	11,650	—	—	14,300*	9400

**Asia Pacific**

**336D2 ● Reach Boom ● 600 mm (24") Track Shoes**

Stick	Bucket		3 m 9'10"		4.5 m 15'0"		6 m 20'0"		7.5 m 25'0"		9 m 30'0"		At Max. Reach	
			Front	Side	Front	Side	Front	Side	Front	Side	Front	Side	Front	Side
3200 mm	1.5 m <sup>3</sup>	kg	6800*	6800*	16 850	11 000	10 500	7100	7350	5000	5450	3700	4400	2900
10'6"	1.97 yd <sup>3</sup>	lb	—	—	—	—	—	—	—	—	—	—	—	—

**China**

**336D2 GC ● Reach Boom ● 600 mm (24") Track Shoes ● 5.2 mt Counterweight**

Stick		3 m 9'10"		4.5 m 15'0"		6 m 20'0"		7.5 m 25'0"		9 m 30'0"		At Max. Reach	
		Front	Side	Front	Side	Front	Side	Front	Side	Front	Side	Front	Side
2800 mm	kg	—	—	16 550	11 000	10 500	7300	7600	5400	—	—	6000	4250
9'2"	lb	—	—	35,550	23,700	22,650	15,750	16,400	11,600	—	—	13,150	9350

\*Load limited by hydraulic capacity rather than tipping.

Asia Pacific

336D2 L ● Reach Boom ● 600 mm (24") Track Shoes

Stick	Bucket		3 m 9'10"		4.5 m 15'0"		6 m 20'0"		7.5 m 25'0"		9 m 30'0"		At Max. Reach	
			Front	Side	Front	Side	Front	Side	Front	Side	Front	Side	Front	Side
3200 mm 10'6"	1.5 m <sup>3</sup> 1.97 yd <sup>3</sup>	kg lb	6800*	6800*	17 500*	11 300	12 450*	7300	8900	5200	6650	3850	4700*	3050
			—	—	—	—	—	—	—	—	—	—	—	—

336D2 L ● Mass Boom ● 600 mm (24") Track Shoes

Stick	Bucket		3 m 9'10"		4.5 m 15'0"		6 m 20'0"		7.5 m 25'0"		9 m 30'0"		At Max. Reach	
			Front	Side	Front	Side	Front	Side	Front	Side	Front	Side	Front	Side
2550 mm 8'4"	1.9 m <sup>3</sup> 2.49 yd <sup>3</sup>	kg lb	—	—	17 150*	10 800	12 250*	6900	8600	4850	—	—	4900*	3200
			—	—	—	—	—	—	—	—	—	—	—	—

\*Load limited by hydraulic capacity rather than tipping.

Middle East, Africa

336D2 L ● Reach Boom ● 700 mm (28") Track Shoes

Stick			3 m 9'10"		4.5 m 15'0"		6 m 20'0"		7.5 m 25'0"		9 m 30'0"		At Max. Reach	
			Front	Side	Front	Side	Front	Side	Front	Side	Front	Side	Front	Side
3200 mm 10'6"		kg lb	—	—	18 900	11 900	13 350	7900	9550	5800	7300	4500	7050	4350
					<b>40,900</b>	<b>25,550</b>	<b>28,700</b>	<b>16,950</b>	<b>20,500</b>	<b>12,450</b>	<b>15,700</b>	<b>9600</b>	<b>15,500</b>	<b>9500</b>
3900 mm 12'10"		kg lb	7850	7850	18 550	11 950	13 350	7950	9550	5800	7300	4450	6200	3850
			<b>17,850</b>	<b>17,850</b>	<b>40,100</b>	<b>25,750</b>	<b>28,900</b>	<b>17,100</b>	<b>20,550</b>	<b>12,500</b>	<b>15,700</b>	<b>9600</b>	<b>13,650</b>	<b>8500</b>

336D2 L ● Mass Boom ● 700 mm (28") Track Shoes

Stick			3 m 9'10"		4.5 m 15'0"		6 m 20'0"		7.5 m 25'0"		9 m 30'0"		At Max. Reach	
			Front	Side	Front	Side	Front	Side	Front	Side	Front	Side	Front	Side
2150 mm 7'1"		kg lb	—	—	18 560*	11 970	13 430*	7860	9530	5730	—	—	8210	4960
					<b>40,950*</b>	<b>26,400</b>	<b>29,600*</b>	<b>17,350</b>	<b>21,000</b>	<b>12,650</b>			<b>18,100</b>	<b>10,950</b>
2550 mm 8'4"		kg lb	—	—	18 560*	12 000	13 440	7860	9500	5690	—	—	7550	4550
					<b>40,950*</b>	<b>26,450</b>	<b>29,650</b>	<b>17,350</b>	<b>20,950</b>	<b>12,550</b>			<b>16,650</b>	<b>10,000</b>

\*Load limited by hydraulic capacity rather than tipping.  
 All weights are without bucket, with quick coupler, heavy lift on.

China, S.E. Asia

336D2 XE ● Reach Boom ● 600 mm (24") Track Shoes ● 5.35 mt Counterweight

Stick			3 m 9'10"		4.5 m 15'0"		6 m 20'0"		7.5 m 25'0"		9 m 30'0"		At Max. Reach	
			Front	Side	Front	Side	Front	Side	Front	Side	Front	Side	Front	Side
2800 mm 9'2"		kg lb	—	—	17 550	11 700	11 100	7750	8050	5700	—	—	6300	4500
					<b>37,600</b>	<b>25,150</b>	<b>23,900</b>	<b>16,700</b>	<b>17,300</b>	<b>12,300</b>			<b>13,850</b>	<b>9900</b>

S.E. Asia, South America, Africa, Middle East, CIS

336D2 L XE ● Mass Boom ● 700 mm (28") Track Shoes ● 5.35 mt Counterweight

Stick			3 m 9'10"		4.5 m 15'0"		6 m 20'0"		7.5 m 25'0"		9 m 30'0"		At Max. Reach	
			Front	Side	Front	Side	Front	Side	Front	Side	Front	Side	Front	Side
2550 mm 8'4"		kg lb	—	—	18 350*	12 150	13 550*	8050	9700	5900	—	—	8350	5150
					<b>39,800*</b>	<b>26,100</b>	<b>29,100</b>	<b>17,300</b>	<b>20,800</b>	<b>12,750</b>			<b>18,400</b>	<b>11,350</b>

\*Load limited by hydraulic capacity rather than tipping.

**North America**

**336E L ● Reach Boom ● 800 mm (32") Track Shoes**

Stick		3 m 9'10"		4.5 m 15'0"		6 m 20'0"		7.5 m 25'0"		9 m 30'0"		At Max. Reach	
		Front	Side	Front	Side	Front	Side	Front	Side	Front	Side	Front	Side
3200 mm 10'6"	kg lb	—	—	20 550 44,550	13 050 28,050	14 450 31,000	8700 18,700	10 300 22,200	6400 13,800	7950 17,100	5000 10,750	8600 18,950	5350 11,800
3900 mm 12'10"	kg lb	8550*	8550*	20 100*	13 050	14 450	8700	10 300	6400	7900	4950	6750*	4300
		19,400*	19,400*	43,450*	28,050	31,000	18,700	22,150	13,700	16,950	10,600	14,850*	9450

**336E L ● Mass Boom ● 800 mm (32") Track Shoes**

Stick		3 m 9'10"		4.5 m 15'0"		6 m 20'0"		7.5 m 25'0"		9 m 30'0"		At Max. Reach	
		Front	Side	Front	Side	Front	Side	Front	Side	Front	Side	Front	Side
2550 mm 8'4"	kg lb	—	—	20 450*	12 900	14 300	8550	10 250	6300	—	—	8850	5500
				44,300*	27,800	30,750	18,450	22,000	13,600			19,450	12,150

**Europe**

**336E L ● Reach Boom ● 600 mm (24") Track Shoes**

Stick		3 m 9'10"		4.5 m 15'0"		6 m 20'0"		7.5 m 25'0"		9 m 30'0"		At Max. Reach	
		Front	Side	Front	Side	Front	Side	Front	Side	Front	Side	Front	Side
2800 mm 9'2"	kg lb	—	—	20 450*	12 950	14 300	8650	10 250	6400	—	—	8000	5050
				44,750*	27,850	30,750	18,600	22,050	13,750			17,650	11,150
3200 mm 10'6"	kg lb	—	—	20 600*	12 950	14 350	8650	10 300	6400	7900	5000	7650	4800
				44,550*	27,900	30,850	18,650	22,100	13,750	17,000	10,700	16,800	10,600

**336E L ● Mass Boom ● 600 mm (24") Track Shoes**

Stick		3 m 9'10"		4.5 m 15'0"		6 m 20'0"		7.5 m 25'0"		9 m 30'0"		At Max. Reach	
		Front	Side	Front	Side	Front	Side	Front	Side	Front	Side	Front	Side
2150 mm 7'1"	kg lb	—	—	20 200*	12 800	14 200	8500	10 200	6300	—	—	9500	5900
				43,850*	27,550	30,450	18,300	21,900	13,600			20,900	13,000
2550 mm 8'4"	kg lb	—	—	20 450*	12 800	14 150	8500	10 150	6250	—	—	8750	5450
				44,300*	27,500	30,450	18,300	21,800	13,500			19,300	12,000

**336E LN ● Reach Boom ● 600 mm (24") Track Shoes**

Stick		3 m 9'10"		4.5 m 15'0"		6 m 20'0"		7.5 m 25'0"		9 m 30'0"		At Max. Reach	
		Front	Side	Front	Side	Front	Side	Front	Side	Front	Side	Front	Side
2800 mm 9'2"	kg lb	—	—	20 450*	11 550	14 050	7750	10 100	5750	—	—	7900	4600
				44,750*	24,850	30,200	16,750	21,700	12,450			17,350	10,100
3200 mm 10'6"	kg lb	—	—	20 550*	11 500	14 050	7750	10 050	5750	7750	4450	7450	4350
				44,550*	24,800	30,200	16,700	21,600	12,350	16,650	9600	16,450	9500

**336E LN ● Mass Boom ● 600 mm (24") Track Shoes**

Stick		3 m 9'10"		4.5 m 15'0"		6 m 20'0"		7.5 m 25'0"		9 m 30'0"		At Max. Reach	
		Front	Side	Front	Side	Front	Side	Front	Side	Front	Side	Front	Side
2150 mm 7'1"	kg lb	—	—	20 200*	11 400	13 950	7650	10 000	5700	—	—	9350	5350
				43,850*	24,550	29,950	16,450	21,550	12,250			20,550	11,750
2550 mm 8'4"	kg lb	—	—	20 450*	11 400	13 900	7600	9950	5650	—	—	8600	4950
				44,300*	24,500	29,900	16,400	21,450	12,150			18,950	10,850

\*Load limited by hydraulic capacity rather than tipping.

North America

336E L H ● Reach Boom ● 850 mm (34") Track Shoes

Stick		3 m 9'10"		4.5 m 15'0"		6 m 20'0"		7.5 m 25'0"		9 m 30'0"		At Max. Reach	
		Front	Side	Front	Side	Front	Side	Front	Side	Front	Side	Front	Side
3200 mm 10'6"	kg lb	—	—	19 850*	12 850	14 300	8550	10 250	6300	7900	4900	7600	4750
				<b>42,950*</b>	<b>27,650</b>	<b>30,750</b>	<b>18,450</b>	<b>22,050</b>	<b>13,600</b>	<b>16,950</b>	<b>10,600</b>	<b>16,750</b>	<b>10,450</b>
3900 mm 12'10"	kg lb	8250*	8250*	19 250*	12 750	13 900*	8500	10 150	6200	7750	4800	6500*	4150
		<b>18,750*</b>	<b>18,750*</b>	<b>41,650*</b>	<b>27,450</b>	<b>30,050*</b>	<b>18,250</b>	<b>21,850</b>	<b>13,400</b>	<b>16,700</b>	<b>10,300</b>	<b>14,300*</b>	<b>9150</b>

Europe

336E L H ● Reach Boom ● 600 mm (24") Track Shoes

Stick		3 m 9'10"		4.5 m 15'0"		6 m 20'0"		7.5 m 25'0"		9 m 30'0"		At Max. Reach	
		Front	Side	Front	Side	Front	Side	Front	Side	Front	Side	Front	Side
2800 mm 9'2"	kg lb	—	—	19 900*	12 850	14 250	8550	10 250	6350	—	—	8000	5000
3200 mm 10'6"	kg lb	—	—	19 850*	12 400	13 800	8250	9900	6100	7600	4750	7350	4600

7

336E LN H ● Reach Boom ● 600 mm (24") Track Shoes

Stick		3 m 9'10"		4.5 m 15'0"		6 m 20'0"		7.5 m 25'0"		9 m 30'0"		At Max. Reach	
		Front	Side	Front	Side	Front	Side	Front	Side	Front	Side	Front	Side
2800 mm 9'2"	kg lb	—	—	19 900*	11 250	13 800	7550	9900	5600	—	—	7750	4450
3200 mm 10'6"	kg lb	—	—	19 850*	11 200	13 750	7500	9850	5550	7550	4350	7300	4200

North America

336F L ● Reach Boom ● 800 mm (32") Track Shoes

Stick		3 m 9'10"		4.5 m 15'0"		6 m 20'0"		7.5 m 25'0"		9 m 30'0"		At Max. Reach	
		Front	Side	Front	Side	Front	Side	Front	Side	Front	Side	Front	Side
3200 mm 10'6"	kg lb	—	—	20 550	13 050	14 450	8700	10 300	6400	7950	5000	8600	5350
				<b>44,550</b>	<b>28,050</b>	<b>31,000</b>	<b>18,700</b>	<b>22,200</b>	<b>13,800</b>	<b>17,100</b>	<b>10,750</b>	<b>18,950</b>	<b>11,800</b>
3900 mm 12'10"	kg lb	8550	8550	20 100	13 050	14 450	8700	10 300	6400	7900	4950	6750	4300
		<b>19,400</b>	<b>19,400</b>	<b>43,450</b>	<b>28,050</b>	<b>31,000</b>	<b>18,700</b>	<b>22,150</b>	<b>13,700</b>	<b>16,950</b>	<b>10,600</b>	<b>14,850</b>	<b>9450</b>

336F L ● Mass Boom ● 800 mm (32") Track Shoes

Stick		3 m 9'10"		4.5 m 15'0"		6 m 20'0"		7.5 m 25'0"		9 m 30'0"		At Max. Reach	
		Front	Side	Front	Side	Front	Side	Front	Side	Front	Side	Front	Side
2550 mm 8'4"	kg lb	—	—	20 450	12 900	14 300	8550	10 250	6300	—	—	8850	5500
				<b>44,300</b>	<b>27,800</b>	<b>30,750</b>	<b>18,450</b>	<b>22,000</b>	<b>13,600</b>			<b>19,450</b>	<b>12,150</b>

\*Load limited by hydraulic capacity rather than tipping.

# Hydraulic Excavators

## Lifting Capacity At Ground Level

- 336F L ● 336F LN ● 336F L XE
- 336F LN XE ● 340D2 L ● 340F L

### North America

#### 336F L ● Reach Boom ● 850 mm (34") Track Shoes ● 6.0 mt Counterweight

Stick		3 m 9'10"		4.5 m 15'0"		6 m 20'0"		7.5 m 25'0"		9 m 30'0"		At Max. Reach	
		Front	Side	Front	Side	Front	Side	Front	Side	Front	Side	Front	Side
3900 mm	kg	8250*	8250*	20 100*	13 600	14 500*	9050	10 700	6650	8200	5150	6750*	4500
12'10"	lb	18,800*	18,800*	43,450*	29,200	31,400*	19,450	23,000	14,300	17,600	11,050	14,800*	9850

### Europe

#### 336F LN ● Reach Boom ● 600 mm (24") Track Shoes ● 7.0 mt Counterweight

Stick		3 m 9'10"		4.5 m 15'0"		6 m 20'0"		7.5 m 25'0"		9 m 30'0"		At Max. Reach	
		Front	Side	Front	Side	Front	Side	Front	Side	Front	Side	Front	Side
3200 mm	kg	—	—	20 300*	12 900	14 800*	8700	11 100	6450	8550	5050	8250	4900
10'6"	lb	—	—	43,950*	27,750	32,000*	18,700	23,900	13,900	18,400	10,850	18,200	10,700

### North America, Europe

#### 336F L XE ● Reach Boom ● 850 mm (34") Track Shoes ● 5.05 mt Counterweight

Stick		3 m 9'10"		4.5 m 15'0"		6 m 20'0"		7.5 m 25'0"		9 m 30'0"		At Max. Reach	
		Front	Side	Front	Side	Front	Side	Front	Side	Front	Side	Front	Side
3900 mm	kg	8250*	8250*	19 450*	13 200	14 050*	8800	10 450	6450	8000	5000	6550*	4350
12'10"	lb	18,800*	18,800*	42,050*	28,400	30,400*	18,900	22,450	13,900	17,200	10,750	14,400*	9550

### Europe

#### 336F LN XE ● Reach Boom ● 600 mm (24") Track Shoes ● 6.05 mt Counterweight

Stick		3 m 9'10"		4.5 m 15'0"		6 m 20'0"		7.5 m 25'0"		9 m 30'0"		At Max. Reach	
		Front	Side	Front	Side	Front	Side	Front	Side	Front	Side	Front	Side
3200 mm	kg	—	—	19 600*	12 600	14 300*	8500	10 950	6300	8400	4950	8150	4750
10'6"	lb	—	—	42,500*	27,150	30,950*	18,350	23,550	13,600	18,100	10,600	17,900	10,500

### China, S.E. Asia, South America except Brazil, Africa, Middle East, CIS

#### 340D2 L ● Mass Boom ● 600 mm (24") Track Shoes ● 6.26 mt Counterweight

Stick		3 m 9'10"		4.5 m 15'0"		6 m 20'0"		7.5 m 25'0"		9 m 30'0"		At Max. Reach	
		Front	Side	Front	Side	Front	Side	Front	Side	Front	Side	Front	Side
2550 mm	kg	—	—	18 350*	15 600	13 550*	10 150	10 550	7450	—	—	9100	6500
8'4"	lb	—	—	39,800*	33,500	29,300*	21,850	22,700	16,050	—	—	20,050	14,250

### Europe

#### 340F L ● Reach Boom ● 600 mm (24") Track Shoes ● 7.0 mt Counterweight

Stick		3 m 9'10"		4.5 m 15'0"		6 m 20'0"		7.5 m 25'0"		9 m 30'0"		At Max. Reach	
		Front	Side	Front	Side	Front	Side	Front	Side	Front	Side	Front	Side
3200 mm	kg	—	—	20 350*	17 350	14 900*	11 400	11 600	8350	8950	6550	8750	6350
10'6"	lb	—	—	44,100*	37,300	32,250*	24,500	25,000	18,000	19,300	14,050	19,250	14,000

\*Load limited by hydraulic capacity rather than tipping.

**Asia Pacific, CIS**

**349D2 ● Reach Boom ● 600 mm (24") Track Shoes ● 9.0 mt Counterweight**

Stick		4.5 m 15'0"		6 m 20'0"		7.5 m 25'0"		9 m 30'0"		10.5 m 35'0"		At Max. Reach	
		Front	Side	Front	Side	Front	Side	Front	Side	Front	Side	Front	Side
2900 mm	kg	18 500*	18 500	17 300*	12 100	13 300	8950	10 250	7000	—	—	9700	6600
9'6"	lb	43,150*	43,150	37,400*	26,050	28,650	19,250	22,100	15,050	—	—	21,400	14,550
3350 mm	kg	19 900*	18 350	17 250*	12 150	13 350	8950	10 250	6950	—	—	9100	6200
11'0"	lb	46,150*	39,450	37,300*	26,150	28,700	19,300	22,100	15,000	—	—	20,050	13,650
3900 mm	kg	22 550*	18 350	17 000*	12 150	13 300*	8950	10 250	6950	—	—	8550	5800
12'10"	lb	50,750*	39,450	36,750*	26,150	28,700	19,250	22,050	14,950	—	—	18,800	12,750

**349D2 ● Mass Boom ● 600 mm (24") Track Shoes ● 9.0 mt Counterweight**

Stick		4.5 m 15'0"		6 m 20'0"		7.5 m 25'0"		9 m 30'0"		10.5 m 35'0"		At Max. Reach	
		Front	Side	Front	Side	Front	Side	Front	Side	Front	Side	Front	Side
2500 mm	kg	22 650*	18 200	17 050*	11 950	13 200	8800	—	—	—	—	10 800	7300
8'2"	lb	49,200*	39,050	36,950*	25,700	28,350	18,900	—	—	—	—	23,750	16,000
3000 mm	kg	23 000*	18 050	16 950*	11 850	13 100	8700	10 050	6750	—	—	9900	6650
9'10"	lb	49,900*	38,750	36,650*	25,550	28,150	18,700	—	—	—	—	21,800	14,650

7

**South America, Asia Pacific, Middle East, Africa, CIS**

**349D2 L ● Reach Boom ● 600 mm (24") Track Shoes ● 9.0 mt Counterweight**

Stick		4.5 m 15'0"		6 m 20'0"		7.5 m 25'0"		9 m 30'0"		10.5 m 35'0"		At Max. Reach	
		Front	Side	Front	Side	Front	Side	Front	Side	Front	Side	Front	Side
2900 mm	kg	18 400*	18 400*	17 300*	12 150	13 550*	9000	11 100*	7000	—	—	10 500*	6650
9'6"	lb	43,000*	39,650	37,400*	26,200	29,400*	19,350	23,950*	15,150	—	—	23,150*	14,650
3350 mm	kg	19 850*	18 450	17 250*	12 200	13 500*	9000	11 100*	7000	—	—	9550*	6250
11'0"	lb	46,050*	39,700	37,300*	26,300	29,250*	19,400	24,000*	15,100	—	—	21,050*	13,750
3900 mm	kg	22 500*	18 450	16 950*	12 250	13 300*	9000	10 950*	7000	—	—	8700*	5850
12'10"	lb	50,750*	39,700	36,750*	26,350	28,750*	19,400	23,750*	15,050	—	—	19,100*	12,850

**349D2 L ● Mass Boom ● 600 mm (24") Track Shoes ● 9.0 mt Counterweight**

Stick		4.5 m 15'0"		6 m 20'0"		7.5 m 25'0"		9 m 30'0"		10.5 m 35'0"		At Max. Reach	
		Front	Side	Front	Side	Front	Side	Front	Side	Front	Side	Front	Side
2500 mm	kg	22 650*	18 300	17 050*	12 000	13 400*	8850	—	—	—	—	11 300*	7300
8'2"	lb	49,250*	39,300	36,950*	25,850	29,000*	19,050	—	—	—	—	24,900*	16,100
3000 mm	kg	23 000*	18 150	16 950*	11 950	13 250*	8750	10 750*	6800	—	—	10 600*	6700
9'10"	lb	49,900*	39,000	36,650*	25,700	28,700*	18,850	—	—	—	—	23,350*	14,750

\*Load limited by hydraulic capacity rather than tipping.



**349F L ● Long Reach Boom ● 900 mm (35") Track Shoes ● Heavy Lift Mode On**

Stick		4.5 m 15'0"		6 m 20'0"		7.5 m 25'0"		9 m 30'0"		10.5 m 35'0"		At Max. Reach	
		Front	Side	Front	Side	Front	Side	Front	Side	Front	Side	Front	Side
4300 mm	kg	18 100*	18 100*	20 050*	12 550	15 550	9250	11 850	7150	9450	5700	8750*	5300
14'1"	lb	41,800*	40,750	43,400*	27,050	33,450	19,900	25,500	15,400	20,350	12,300	19,250*	11,700

**349F L ● Reach Boom ● 900 mm (35") Track Shoes ● Heavy Lift Mode On**

Stick		4.5 m 15'0"		6 m 20'0"		7.5 m 25'0"		9 m 30'0"		10.5 m 35'0"		At Max. Reach	
		Front	Side	Front	Side	Front	Side	Front	Side	Front	Side	Front	Side
3350 mm	kg	20 950*	19 850	21 150*	13 150	16 000	9700	12 250	7550	—	—	10 400*	6700
11'0"	lb	48,650*	42,700	45,800*	28,300	34,400	20,850	26,350	16,250	—	—	22,900*	14,800
3900 mm	kg	23 800*	19 700	20 700*	13 050	15 900	9600	12 150	7450	—	—	9400*	6250
12'10"	lb	55,050*	42,450	44,850*	28,150	34,250	20,700	26,150	16,050	—	—	20,700*	13,700

**349F L XE ● Reach Boom ● 900 mm (35") Track Shoes  
● 9.0 mt Counterweight ● Heavy Lift Mode On**

Stick		4.5 m 15'0"		6 m 20'0"		7.5 m 25'0"		9 m 30'0"		10.5 m 35'0"		At Max. Reach	
		Front	Side	Front	Side	Front	Side	Front	Side	Front	Side	Front	Side
3350 mm	kg	20 950*	20 200	21 150*	13 350	16 200	9850	12 450	7700	—	—	10 400*	6850
11'0"	lb	48,650*	43,400	45,800*	28,750	34,900	21,200	26,750	16,550	—	—	22,900*	15,050
3900 mm	kg	23 800*	20 050	20 700*	13 250	16 150	9750	12 350	7600	—	—	9400*	6350
12'10"	lb	55,050*	43,150	44,850*	28,600	34,750	21,050	26,550	16,350	—	—	20,700*	13,950

\*Load limited by hydraulic capacity rather than tipping.

**352F ● Reach Boom ● 600 mm (24") Track Shoes ● 9.0 mt Counterweight ● Heavy Lift Mode On**

Stick		4.5 m 15'0"		6 m 20'0"		7.5 m 25'0"		9 m 30'0"		10.5 m 35'0"		At Max. Reach	
		Front	Side	Front	Side	Front	Side	Front	Side	Front	Side	Front	Side
2900 mm	kg	21 650*	21 650*	21 350*	14 400	16 350	10 600	12 550	8300	—	—	12 100	8000
9'6"	lb	50,250*	47,300	46,200*	31,050	35,200	22,850	27,050	17,900	—	—	26,650	17,600
3350 mm	kg	21 550*	21 550*	21 150*	14 350	16 300	10 550	12 500	8250	—	—	10 500*	7350
11'0"	lb	49,900*	47,100	45,850*	30,900	35,050	22,750	26,900	17,750	—	—	23,150*	16,250

**352F ● Mass Boom ● 600 mm (24") Track Shoes ● 9.0 mt Counterweight ● Heavy Lift Mode On**

Stick		4.5 m 15'0"		6 m 20'0"		7.5 m 25'0"		9 m 30'0"		10.5 m 35'0"		At Max. Reach	
		Front	Side	Front	Side	Front	Side	Front	Side	Front	Side	Front	Side
2500 mm	kg	25 200*	21 750	20 950*	14 150	16 150	10 400	—	—	—	—	13 300	8650
8'2"	lb	59,000*	46,750	45,400*	30,500	34,800	22,400	—	—	—	—	29,250	19,050
3000 mm	kg	26 700*	21 550	20 800*	14 050	16 050	10 300	12 300	8000	—	—	12 150	7900
9'10"	lb	61,250*	46,350	45,050*	30,250	34,550	22,150	—	—	—	—	26,800	17,450

7

**352F ● Long Reach Boom ● 900 mm (35") Track Shoes ● Heavy Lift Mode On**

Stick		3 m 9'10"		4.5 m 15'0"		6 m 20'0"		At Max. Reach	
		Front	Side	Front	Side	Front	Side	Front	Side
4300 mm	kg	7500*	7500*	18 350*	18 350*	20 150*	13 900	8850*	5950
14'1"	lb	17,000*	17,000*	42,250*	42,250*	43,550*	29,950	19,450*	13,050

Stick		7.5 m 25'0"		9 m 30'0"		10.5 m 35'0"		At Max. Reach	
		Front	Side	Front	Side	Front	Side	Front	Side
4300 mm	kg	15 700*	10 200	12 300	7900	9850	6350	8850*	5950
14'1"	lb	33,950*	22,000	26,500	17,050	21,150	13,650	19,450*	13,050

**352F ● Reach Boom ● 900 mm (35") Track Shoes ● Heavy Lift Mode On**

Stick		3 m 9'10"		4.5 m 15'0"		6 m 20'0"		At Max. Reach	
		Front	Side	Front	Side	Front	Side	Front	Side
3350 mm	kg	—	—	21 500*	21 500*	21 200*	14 500	10 550*	7450
11'0"	lb	—	—	49,850*	47,600	45,900*	31,250	23,200*	16,400
3900 mm	kg	9650*	9650*	24 050*	22 000	20 800*	14 450	9550*	6950
12'10"	lb	21,850*	21,850*	55,600*	47,250	45,000*	31,050	21,000*	15,250

Stick		7.5 m 25'0"		9 m 30'0"		10.5 m 35'0"		At Max. Reach	
		Front	Side	Front	Side	Front	Side	Front	Side
3350 mm	kg	16 550	10 700	12 700	8350	—	—	10 550*	7450
11'0"	lb	35,650	23,000	27,350	17,950	—	—	23,200*	16,400
3900 mm	kg	16 300*	10 600	12 600	8200	—	—	9550*	6950
12'10"	lb	35,250*	22,800	27,150	17,700	—	—	21,000*	15,250

\*Load limited by hydraulic capacity rather than tipping.

**352F XE ● Reach Boom ● 600 mm (24") Track Shoes  
● 9.0 mt Counterweight ● Heavy Lift Mode On**

Stick		4.5 m 15'0"		6 m 20'0"		7.5 m 25'0"		9 m 30'0"		10.5 m 35'0"		At Max. Reach	
		Front	Side	Front	Side	Front	Side	Front	Side	Front	Side	Front	Side
2900 mm	kg	21 650*	21 650*	21 350*	14 650	16 600	10 800	12 750	8450			12 250	8150
9'6"	lb	<b>50,250*</b>	<b>48,050</b>	<b>46,200*</b>	<b>31,550</b>	<b>35,700</b>	<b>23,250</b>	<b>27,450</b>	<b>18,200</b>	—	—	<b>27,000</b>	<b>17,900</b>
3350 mm	kg	21 550*	21 550*	21 150*	14 600	16 500	10 750	12 700	8350			10 500*	7500
11'0"	lb	<b>49,900*</b>	<b>47,850</b>	<b>45,850*</b>	<b>31,400</b>	<b>35,550</b>	<b>23,100</b>	<b>27,300</b>	<b>18,000</b>	—	—	<b>23,150*</b>	<b>16,500</b>

**352F XE ● Mass Boom ● 600 mm (24") Track Shoes  
● 9.0 mt Counterweight ● Heavy Lift Mode On**

Stick		4.5 m 15'0"		6 m 20'0"		7.5 m 25'0"		9 m 30'0"		10.5 m 35'0"		At Max. Reach	
		Front	Side	Front	Side	Front	Side	Front	Side	Front	Side	Front	Side
2500 mm	kg	25 200*	22 100	20 950*	14 400	16 400	10 550					13 450	8800
8'2"	lb	<b>59,000*</b>	<b>47,500</b>	<b>45,400*</b>	<b>31,000</b>	<b>35,300</b>	<b>22,750</b>	—	—	—	—	<b>29,650</b>	<b>19,400</b>
3000 mm	kg	26 700*	21 900	20 800*	14 300	16 300	10 450	12 450	8150			12 350	8050
9'10"	lb	<b>61,250*</b>	<b>47,050</b>	<b>45,050*</b>	<b>30,750</b>	<b>35,050</b>	<b>22,500</b>	—	—	—	—	<b>27,200</b>	<b>17,750</b>

**374F L ● 7.8 m (25'7") Reach Boom ● 900 mm (35") Double Grousers**

Stick		4.5 m 15'0"		6 m 20'0"		7.5 m 25'0"		9 m 30'0"		10.5 m 35'0"		At Max. Reach	
		Front	Side	Front	Side	Front	Side	Front	Side	Front	Side	Front	Side
2840 mm	kg	—	—	28 450*	23 000	22 750*	16 700	18 150	13 000			15 250	11 000
9'4"	lb	—	—	<b>61,800*</b>	<b>49,450</b>	<b>49,300*</b>	<b>35,950</b>	<b>39,100</b>	<b>28,050</b>	—	—	<b>33,550</b>	<b>24,250</b>
3600 mm	kg	—	—	28 850*	23 000	22 750*	16 700	18 100	12 950	14 550	10 500	13 850	10 000
11'10"	lb	<b>36,750*</b>	<b>36,750*</b>	<b>62,550*</b>	<b>49,500</b>	<b>49,200*</b>	<b>35,950</b>	<b>39,000</b>	<b>27,950</b>	<b>31,300</b>	<b>22,600</b>	<b>30,550</b>	<b>22,050</b>
4150 mm	kg	17 900*	17 900*	28 800*	23 000	22 550*	16 700	18 100	12 950	14 500	10 450	12 900	9350
13'7"	lb	<b>41,350*</b>	<b>41,350*</b>	<b>62,300*</b>	<b>49,550</b>	<b>48,800*</b>	<b>36,000</b>	<b>38,950</b>	<b>27,900</b>	<b>31,200</b>	<b>22,450</b>	<b>28,450</b>	<b>20,550</b>
4670 mm	kg	18 350*	18 350*	28 450*	23 050	22 200*	16 700	18 050	12 900	14 400	10 350	12 000	8600
15'4"	lb	<b>42,350*</b>	<b>42,350*</b>	<b>61,550*</b>	<b>49,550</b>	<b>48,000*</b>	<b>35,950</b>	<b>38,850</b>	<b>27,800</b>	<b>31,000</b>	<b>22,300</b>	<b>26,350</b>	<b>19,000</b>

**374F L ● 7.0 m (23'0") Mass Boom ● 900 mm (35") Double Grousers**

Stick		4.5 m 15'0"		6 m 20'0"		7.5 m 25'0"		9 m 30'0"		10.5 m 35'0"		At Max. Reach	
		Front	Side	Front	Side	Front	Side	Front	Side	Front	Side	Front	Side
2570 mm	kg	28 500*	28 500*	28 650*	23 150	22 650*	16 750	18 250	13 050			18 050	12 900
8'5"	lb	<b>66,800*</b>	<b>66,800*</b>	<b>62,150*</b>	<b>49,800</b>	<b>49,050*</b>	<b>36,100</b>	—	—	—	—	<b>39,700</b>	<b>28,450</b>
3000 mm	kg	30 800*	30 800*	28 650*	23 000	22 550*	16 650	18 100	12 900			16 800	12 050
9'10"	lb	<b>71,400*</b>	<b>71,400*</b>	<b>62,100*</b>	<b>49,550</b>	<b>48,850*</b>	<b>35,850</b>	<b>38,950</b>	<b>27,800</b>	—	—	<b>37,050</b>	<b>26,500</b>

\*Load limited by hydraulic capacity rather than tipping.

**374F L ● 7.8 m (25'7") Reach Boom ● 750 mm (30") Double Grousers**

Stick		4.5 m 15'0"		6 m 20'0"		7.5 m 25'0"		9 m 30'0"		10.5 m 35'0"		At Max. Reach	
		Front	Side	Front	Side	Front	Side	Front	Side	Front	Side	Front	Side
2840 mm 9'4"	kg lb	—	—	28 450* 61,800*	22 650 48,700	22 750* 49,300*	16 450 35,400	17 900 38,550	12 800 27,650	—	—	15 000 33,050	10 850 23,900
3600 mm 11'10"	kg lb	—	—	28 850* 62,550*	22 650 48,750	22 750* 49,200*	16 450 35,450	17 850 38,400	12 750 27,500	14 300 30,850	10 350 22,250	13 650 30,100	9850 21,750
4150 mm 13'7"	kg lb	17 900* 41,350*	17 900* 41,350*	28 800* 62,300*	22 700 48,850	22 550* 48,800*	16 450 35,450	17 850 38,400	12 750 27,500	14 250 30,700	10 300 22,150	12 700 28,000	9200 20,200
4670 mm 15'4"	kg lb	18 350* 42,350*	18 350* 42,350*	28 450* 61,550*	22 700 48,850	22 200* 48,000*	16 450 35,400	17 800 38,300	12 700 27,350	14 200 30,550	10 200 21,950	11 800 25,950	8500 18,700

**374F L ● 7.0 m (23'0") Mass Boom ● 750 mm (30") Double Grousers**

Stick		4.5 m 15'0"		6 m 20'0"		7.5 m 25'0"		9 m 30'0"		10.5 m 35'0"		At Max. Reach	
		Front	Side	Front	Side	Front	Side	Front	Side	Front	Side	Front	Side
2570 mm 8'5"	kg lb	28 500* 66,800*	28 500* 66,800*	28 650* 62,150*	22 800 49,050	22 650* 49,050*	16 500 35,600	18 000 —	12 850 —	—	—	17 750 39,150	12 700 28,000
3000 mm 9'10"	kg lb	30 800* 71,400*	30 800* 71,400*	28 650* 62,100*	22 700 48,800	22 550* 48,850	16 400 35,350	17 850 38,400	12 700 27,400	—	—	16 550 36,450	11 850 26,100

**374F L ● 7.8 m (25'7") Reach Boom ● 650 mm (26") Double Grousers**

Stick		4.5 m 15'0"		6 m 20'0"		7.5 m 25'0"		9 m 30'0"		10.5 m 35'0"		At Max. Reach	
		Front	Side	Front	Side	Front	Side	Front	Side	Front	Side	Front	Side
2840 mm 9'4"	kg lb	—	—	28 450* 61,800*	22 400 48,250	22 750* 49,300*	16 250 35,050	17 700 38,150	12 700 27,350	—	—	14 850 32,700	10 750 23,650
3600 mm 11'10"	kg lb	—	—	28 850* 62,550*	22 450 48,300	22 750* 49,200*	16 300 35,100	17 650 38,000	12 650 27,250	14 150 30,500	10 200 22,000	13 500 29,750	9750 21,500
4150 mm 13'7"	kg lb	17 900* 41,350*	17 900* 41,350*	28 800* 62,300*	22 450 48,350	22 550* 48,800*	16 300 35,100	17 650 38,000	12 650 27,200	14 100 30,400	10 150 21,900	12 600 27,700	9100 20,000

\*Load limited by hydraulic capacity rather than tipping.

**390F L ● 8.4 m (27'7") GP Boom ● 900 mm (35") Track Shoes**

Stick		4.5 m 15'0"		6 m 20'0"		7.5 m 25'0"		9 m 30'0"	
		Front	Side	Front	Side	Front	Side	Front	Side
3400 mm 11'2"	kg	—	—	33 250*	28 550	28 200*	20 500	23 100*	15 850
	lb	—	—	76,750*	61,350	61,150*	44,150	50,050*	34,150
4400 mm 14'5"	kg	—	—	36 500*	29 050	28 650*	21 050	23 450*	16 300
	lb	—	—	79,150*	62,550	62,000*	45,300	50,750*	35,100
5500 mm 18'1"	kg	18 900*	18 900*	35 800*	29 150	27 750*	21 050	22 700*	16 250
	lb	43,300*	43,300*	77,500*	62,750	60,100*	45,400	49,100*	34,950

Stick		10.5 m 35'0"		12 m 40'0"		13.5 m 45'0"		At Max. Reach	
		Front	Side	Front	Side	Front	Side	Front	Side
3400 mm 11'2"	kg	19 350*	12 800	—	—	—	—	17 050	11 450
	lb	41,700	27,500	—	—	—	—	37,500	25,200
4400 mm 14'5"	kg	19 700	13 100	16 250	10 850	—	—	13 300*	10 600
	lb	42,400	28,250	29,700*	23,350	—	—	29,250*	23,300
5500 mm 18'1"	kg	19 200*	13 000	16 050	10 650	—	—	9600*	9150
	lb	41,600*	27,950	34,550	22,900	—	—	21,100*	20,200

**390F L ● 10 m (32'10") Reach Boom ● 900 mm (35") Track Shoes**

Stick		4.5 m 15'0"		6 m 20'0"		7.5 m 25'0"		9 m 30'0"	
		Front	Side	Front	Side	Front	Side	Front	Side
4400 mm 14'5"	kg	—	—	13 250*	13 250*	26 400*	18 700	21 650*	14 550
	lb	—	—	31,500*	31,500*	57,150*	40,250	46,850*	31,350
5500 mm 18'1"	kg	—	—	16 950*	16 950*	25 950*	18 600	21 100*	14 450
	lb	—	—	39,400*	39,400*	56,200*	40,150	45,650*	31,150

Stick		10.5 m 35'0"		12 m 40'0"		13.5 m 45'0"		At Max. Reach	
		Front	Side	Front	Side	Front	Side	Front	Side
4400 mm 14'5"	kg	18 250*	11 750	15 100	9750	12 750	8200	12 400	8000
	lb	39,450*	25,350	32,550	20,950	27,450	17,650	27,350	17,550
5500 mm 18'1"	kg	17 700*	11 650	15 000	9600	12 550	8000	10 950	6900
	lb	38,300*	25,050	32,200	20,600	27,000	17,150	24,100	15,200

**390F L ● 7.25 m (23'9") Mass Boom ● 900 mm (35") Track Shoes**

Stick		4.5 m 15'0"		6 m 20'0"		7.5 m 25'0"		9 m 30'0"	
		Front	Side	Front	Side	Front	Side	Front	Side
2920 mm 9'7"	kg	26 100*	26 100*	36 200*	29 850	28 800*	21 500	23 250*	16 650
	lb	60,800*	60,800*	78,600*	64,200	62,300*	46,300	50,100*	35,850
3400 mm 11'2"	kg	27 900*	27 900*	36 650*	29 750	28 900*	21 400	23 450*	16 500
	lb	64,500*	64,500*	79,450*	64,000	62,550*	46,050	50,650*	35,500

Stick		10.5 m 35'0"		12 m 40'0"		13.5 m 45'0"		At Max. Reach	
		Front	Side	Front	Side	Front	Side	Front	Side
2920 mm 9'7"	kg	—	—	—	—	—	—	20 900*	15 150
	lb	—	—	—	—	—	—	46,100*	33,400
3400 mm 11'2"	kg	—	—	—	—	—	—	19 400*	14 050
	lb	—	—	—	—	—	—	42,800*	30,950

\*Load limited by hydraulic capacity rather than tipping.

**390F L ● 8.4 m (27'7") GP Boom ● 650 mm (26") Track Shoes**

Stick		4.5 m 15'0"		6 m 20'0"		7.5 m 25'0"		9 m 30'0"	
		Front	Side	Front	Side	Front	Side	Front	Side
3400 mm 11'2"	kg lb	—	—	33 250* 76,750*	27 850 59,900	28 200* 61,150*	20 000 43,100	23 100* 50,050*	15 450 33,300
4400 mm 14'5"	kg lb	—	—	36 500* 79,150*	28 400 61,100	28 650* 62,000*	20 550 44,250	23 450* 50,750*	15 900 34,250
5500 mm 18'1"	kg lb	18 900* 43,300*	18 900* 43,300*	35 800* 77,500*	28 500 61,300	27 750* 60,100*	20 600 44,350	22 700* 49,100*	15 850 34,150

Stick		10.5 m 35'0"		12 m 40'0"		13.5 m 45'0"		At Max. Reach	
		Front	Side	Front	Side	Front	Side	Front	Side
3400 mm 11'2"	kg lb	18 900 40,700	12 450 26,850	—	—	—	—	16 850 37,150	11 150 24,550
4400 mm 14'5"	kg lb	19 250 41,400	12 800 27,550	15 850 29,700*	10 600 22,750	—	—	13 300* 29,250*	10 350 22,750
5500 mm 18'1"	kg lb	19 150 41,200	12 700 27,300	15 650 33,700	10 400 22,350	—	—	9600* 21,100*	8950 19,650

**390F L ● 10 m (32'10") Reach Boom ● 650 mm (26") Track Shoes**

Stick		4.5 m 15'0"		6 m 20'0"		7.5 m 25'0"		9 m 30'0"	
		Front	Side	Front	Side	Front	Side	Front	Side
4400 mm 14'5"	kg lb	—	—	13 250* 31,500*	13 250* 31,500*	26 400* 57,150*	18 200 39,200	21 650* 46,850*	14 150 30,500
5500 mm 18'1"	kg lb	—	—	16 950* 39,400*	16 950* 39,400*	25 950* 56,200*	18 150 39,100	21 100* 45,650*	14 100 30,350

Stick		10.5 m 35'0"		12 m 40'0"		13.5 m 45'0"		At Max. Reach	
		Front	Side	Front	Side	Front	Side	Front	Side
4400 mm 14'5"	kg lb	17 850 38,450	11 450 24,650	14 750 31,700	9450 20,400	12 400 26,750	7950 17,150	12 100 26,600	7750 17,050
5500 mm 18'1"	kg lb	17 700* 38,250	11 350 24,350	14 600 31,350	9300 20,000	12 200 26,250	7750 16,650	10 650 23,450	6700 14,750

**390F L ● 8.4 m (27'7") GP Boom ● 750 mm (30") Track Shoes**

Stick		4.5 m 15'0"		6 m 20'0"		7.5 m 25'0"		9 m 30'0"	
		Front	Side	Front	Side	Front	Side	Front	Side
3400 mm 11'2"	kg lb	—	—	33 250* 76,750*	28 150 60,550	28 200* 61,150*	20 250 43,600	23 100* 50,050*	15 650 33,700
4400 mm 14'5"	kg lb	—	—	36 500* 79,150*	28 700 61,750	28 650* 62,000*	20 750 44,750	23 450* 50,750*	16 100 34,650
5500 mm 18'1"	kg lb	18 900* 43,300*	18 900* 43,300*	35 800* 77,500*	28 800 62,000	27 750* 60,100*	20 800 44,800	22 700* 49,100*	16 050 34,500

Stick		10.5 m 35'0"		12 m 40'0"		13.5 m 45'0"		At Max. Reach	
		Front	Side	Front	Side	Front	Side	Front	Side
3400 mm 11'2"	kg lb	19 100 41,150	12 600 27,150	—	—	—	—	17 050* 37,500*	11 300 24,850
4400 mm 14'5"	kg lb	19 450 41,850	12 950 27,850	16 000 29,700*	10 700 23,050	—	—	13 300* 29,250*	10 450 23,000
5500 mm 18'1"	kg lb	19 200* 41,600*	12 800 27,600	15 850 34,100	10 500 22,600	—	—	9600* 21,100*	9050 19,900

\*Load limited by hydraulic capacity rather than tipping.

**390F L ● 10 m (32'10") Reach Boom ● 750 mm (30") Track Shoes**

Stick		4.5 m 15'0"		6 m 20'0"		7.5 m 25'0"		9 m 30'0"	
		Front	Side	Front	Side	Front	Side	Front	Side
4400 mm	kg	—	—	13 250*	13 250*	26 400*	18 400	21 650*	14 350
14'5"	lb	—	—	31,500*	31,500*	57,150*	39,700	46,850*	30,900
5500 mm	kg	—	—	16 950*	16 950*	25 950*	18 350	21 100*	14 250
18'1"	lb	—	—	39,400*	39,400*	56,200*	39,550	45,650*	30,700

Stick		10.5 m 35'0"		12 m 40'0"		13.5 m 45'0"		At Max. Reach	
		Front	Side	Front	Side	Front	Side	Front	Side
4400 mm	kg	18 100	11 600	14 900	9600	12 550	8100	12 250	7850
14'5"	lb	38,950	24,950	32,100	20,650	27,050	17,350	26,950	17,300
5500 mm	kg	17 700*	11 450	14 750	9450	12 350	7850	10 800	6800
18'1"	lb	38,300*	24,700	31,750	20,250	26,600	16,900	23,750	14,950

**390F L ● 7.25 m (23'9") Mass Boom ● 650 mm (26") Track Shoes**

Stick		4.5 m 15'0"		6 m 20'0"		7.5 m 25'0"		9 m 30'0"	
		Front	Side	Front	Side	Front	Side	Front	Side
2920 mm	kg	26 100*	26 100*	36 200*	29 200	28 800*	21 000	23 250*	16 250
9'7"	lb	60,800*	60,800*	78,600*	62,800	62,300*	45,250	50,100*	35,050
3400 mm	kg	27 900*	27 900*	36 650*	29 100	28 900*	20 900	23 450	16 100
11'2"	lb	64,500*	64,500*	79,450*	62,550	62,550*	45,000	50,650	34,650

Stick		10.5 m 35'0"		12 m 40'0"		13.5 m 45'0"		At Max. Reach	
		Front	Side	Front	Side	Front	Side	Front	Side
2920 mm	kg	—	—	—	—	—	—	20 900*	14 800
9'7"	lb	—	—	—	—	—	—	46,100*	32,600
3400 mm	kg	—	—	—	—	—	—	19 400*	13 700
11'2"	lb	—	—	—	—	—	—	42,800*	30,200

**390F L ● 7.25 m (23'9") Mass Boom ● 750 mm (30") Track Shoes**

Stick		4.5 m 15'0"		6 m 20'0"		7.5 m 25'0"		9 m 30'0"	
		Front	Side	Front	Side	Front	Side	Front	Side
2920 mm	kg	26 100*	26 100*	36 200*	29 500	28 800*	21 250	23 250*	16 450
9'7"	lb	60,800*	60,800*	78,600*	63,450	62,300*	45,700	50,100*	35,400
3400 mm	kg	27 900*	27 900*	36 650*	29 400	28 900*	21 100	23 450*	16 250
11'2"	lb	64,500*	64,500*	79,450*	63,200	62,550*	45,450	50,650*	35,050

Stick		10.5 m 35'0"		12 m 40'0"		13.5 m 45'0"		At Max. Reach	
		Front	Side	Front	Side	Front	Side	Front	Side
2920 mm	kg	—	—	—	—	—	—	20 900*	14 950
9'7"	lb	—	—	—	—	—	—	46,100*	32,950
3400 mm	kg	—	—	—	—	—	—	19 400*	13 850
11'2"	lb	—	—	—	—	—	—	42,800*	30,550

\*Load limited by hydraulic capacity rather than tipping.

**390F L ● 8.4 m (27'7") GP Boom ● 650 mm (26") Track Shoes**

Stick		4.5 m 15'0"		6 m 20'0"		7.5 m 25'0"		9 m 30'0"	
		Front	Side	Front	Side	Front	Side	Front	Side
3400 mm 11'2"	kg lb	—	—	33 250* 76,750*	27 850 59,900	28 200* 61,150*	20 000 43,100	23 100* 50,050*	15 450 33,300
4400 mm 14'5"	kg lb	—	—	36 500* 79,150*	28 400 61,100	28 650* 62,000*	20 550 44,250	23 450* 50,750*	15 900 34,250
5500 mm 18'1"	kg lb	18 900* 43,300*	18 900* 43,300*	35 800* 77,500*	28 500 61,300	27 750* 60,100*	20 600 44,350	22 700* 49,100*	15 850 34,150
Stick		10.5 m 35'0"		12 m 40'0"		13.5 m 45'0"		At Max. Reach	
		Front	Side	Front	Side	Front	Side	Front	Side
3400 mm 11'2"	kg lb	18 900 40,700	12 450 26,850	—	—	—	—	16 850 37,150	11 150 24,550
4400 mm 14'5"	kg lb	19 250 41,400	12 800 27,550	15 850 29,700*	10 600 22,750	—	—	13 300* 29,250*	10 350 22,750
5500 mm 18'1"	kg lb	19 150 41,200	12 700 27,300	15 650 33,700	10 400 22,350	—	—	9600* 21,100*	8950 19,650

**390F L ● 10 m (32'10") Reach Boom ● 650 mm (26") Track Shoes**

Stick		4.5 m 15'0"		6 m 20'0"		7.5 m 25'0"		9 m 30'0"	
		Front	Side	Front	Side	Front	Side	Front	Side
4400 mm 14'5"	kg lb	—	—	13 250* 31,500*	13 250* 31,500*	26 400* 57,150*	18 200 39,200	21 650* 46,850*	14 150 30,500
5500 mm 18'1"	kg lb	—	—	16 950* 39,400*	16 950 39,400	25 950* 56,200*	18 150 39,100	21 100* 45,650*	14 100 30,350
Stick		10.5 m 35'0"		12 m 40'0"		13.5 m 45'0"		At Max. Reach	
		Front	Side	Front	Side	Front	Side	Front	Side
4400 mm 14'5"	kg lb	17 850 38,450	11 450 24,650	14 750 31,700	9450 20,400	12 400 26,750	7950 17,150	12 100 26,600	7750 17,050
5500 mm 18'1"	kg lb	17 700* 38,250	11 350 24,350	14 600 31,350	9300 20,000	12 200 26,250	7750 16,650	10 650 23,450	6700 14,750

\*Load limited by hydraulic capacity rather than tipping.



Model	Bucket Family	Interface	Bucket Type	Width Range		Capacity Range		Weight Range		GET
				mm	in	m <sup>3</sup>	yd <sup>3</sup>	kg	lb	
311F 312E 314E	312	Pin-On/ Pin Grabber	General Duty	450-1200	18-48	0.20-0.76	0.27-1.00	266-487	585-1074	J250
			General Duty Wide Tip	450-1200	18-48	0.27-1.00	0.35-1.33	317-579	699-1276	J250
			Severe Duty	600-1050	24-42	0.31-0.65	0.40-0.84	351-502	774-1106	J300
			Cleanup	1500	60	1.02	1.33	630	1389	BOCE
			Ditch Cleaning	1200-1500	48-60	0.57-0.73	0.75-0.95	389-456	858-1005	BOCE
			Ditch Cleaning Tilt	1500	60	0.57	0.75	514	1133	None
		Dedicated	General Duty	600-1050	24-42	0.30-0.64	0.39-0.83	314-445	693-982	J250
			Heavy Duty Rock	600-1050	24-42	0.30-0.63	0.39-0.82	377-515	831-1134	J300
			Ditch Cleaning	1500	60	0.74	0.97	465	1025	BOCE
Pin-Lock	Heavy Duty	600-900	24-36	0.38-0.61	0.50-0.80	338-433	745-955	J250		
	Ditch Cleaning	1500	60	0.69	0.90	429	945	BOCE		
316E 316F M314F M316F M318F	315	Pin-On/ Pin Grabber	General Duty	600-1200	24-48	0.35-0.91	0.46-1.19	429-625	945-1378	K80
			General Duty Wide Tip	600-1200	24-48	0.42-1.17	0.55-1.53	449-700	990-1543	K80
			Severe Duty	600-1200	24-48	0.35-0.91	0.46-1.19	480-730	1058-1609	K90
			Cleanup	1500	60	1.24	1.62	770	1698	BOCE
			Ditch Cleaning	1500-1820	60-72	0.93-1.14	1.23-1.50	582-663	1283-1462	BOCE
			Ditch Cleaning Tilt	1500	60	0.70	0.87	809	1783	BOCE
		Center-Lock™ Pin Grabber Performance	General Duty	600-900	24-36	0.33-0.57	0.43-0.75	413-539	910-1188	K80
			Severe Duty	1050-1200	24-48	0.70-0.83	0.92-1.09	664-731	1464-1612	K90
		Dedicated	General Duty	600-1050	24-42	0.42-0.92	0.55-1.20	406-570	896-1257	K80
			Severe Duty	600-1050	24-42	0.42-0.88	0.55-1.15	515-713	1135-1573	K90
			Ditch Cleaning	1820	72	1.14	1.49	662	1459	BOCE
		Pin-Lock	Heavy Duty	600-1200	24-48	0.38-0.92	0.50-1.20	540-834	1190-1839	J300
Ditch Cleaning	1200-1800		48-72	0.61-0.99	0.80-1.30	481-650	1060-1434	BOCE		
318E 318F	315	Pin-On/ Pin Grabber	General Duty	900-1200	36-48	0.62-0.91	0.81-1.91	538-661	1186-1457	K80
			Heavy Duty	600-1200	24-48	0.35-0.91	0.46-1.19	449-679	990-1497	K80
			Severe Duty	900-1050	36-42	0.62-0.76	0.81-1.00	625-683	1378-1506	K80
			Cleanup	1500	60	1.24	1.62	770	1698	BOCE
			Ditch Cleaning	1500	60	0.93	1.22	582	1283	BOCE
			Ditch Cleaning Tilt	1500	60	0.70	0.87	809	1783	BOCE
		Center-Lock Pin Grabber Performance	General Duty	600-900	24-36	0.33-0.57	0.43-0.75	413-539	910-1188	K80
			Severe Duty	1050-1200	24-48	0.70-0.83	0.92-1.09	664-731	1464-1612	K90
319D M318D M320F	B	Pin-On/ Pin Grabber	General Duty	600-1400	24-55	0.39-1.18	0.50-1.54	458-730	1010-1609	K80
			Heavy Duty	900-1200	36-48	0.68-0.98	0.88-1.29	605-707	1335-1559	K80

Model	Bucket Family	Interface	Bucket Type	Width Range		Capacity Range		Weight Range		GET
				mm	in	m <sup>3</sup>	yd <sup>3</sup>	kg	lb	
320F 323F 325F M322F	B	Pin-On/ Pin Grabber	General Duty	600-1350	<b>24-54</b>	0.55-1.59	<b>0.72-2.08</b>	601-963	<b>1324-2124</b>	K80
			General Duty Wide Tip	600-1350	<b>24-54</b>	0.55-1.59	<b>0.72-2.08</b>	615-1016	<b>1356-2239</b>	K80
			Heavy Duty	600-1350	<b>24-54</b>	0.46-1.38	<b>0.61-1.81</b>	629-1006	<b>1387-2217</b>	K90
			Heavy Duty Power	900-1200	<b>36-48</b>	0.79-1.14	<b>1.03-1.49</b>	808-952	<b>1781-2099</b>	K90
			Severe Duty	600-1200	<b>24-48</b>	0.46-1.19	<b>0.61-1.56</b>	674-1012	<b>1485-2231</b>	K90
			Severe Duty Power	900	<b>36</b>	0.79	<b>1.03</b>	874	<b>1926</b>	K90
			Cleanup	1800	<b>72</b>	1.60	<b>2.09</b>	979	<b>2158</b>	BOCE
			Ditch Cleaning	1500-1800	<b>60-72</b>	1.02-1.24	<b>1.33-1.63</b>	652-740	<b>1437-1631</b>	BOCE
			Ditch Cleaning Tilt	1500-1800	<b>60-72</b>	0.86-0.96	<b>1.12-1.25</b>	1032-1104	<b>2275-2433</b>	BOCE
		Center-Lock Pin Grabber Performance	Heavy Duty	600-1350	<b>24-54</b>	0.44-1.28	<b>0.57-1.67</b>	656-1056	<b>1446-2328</b>	K90
		Dedicated	General Duty	1200	<b>48</b>	1.38	<b>1.80</b>	956	<b>2107</b>	K80
Heavy Duty	675-1350	<b>27-54</b>	0.54-1.37	<b>0.71-1.80</b>	701-1036	<b>1545-2285</b>	K90			
Ditch Cleaning	1500	<b>60</b>	1.01	<b>1.32</b>	686	<b>1512</b>	BOCE			
323F LR 326F LR 330F LR	A	Pin-On/ Pin Grabber	General Purpose	900	<b>36</b>	0.53	<b>0.69</b>	403	<b>888</b>	J250
			Ditch Cleaning	1200	<b>48</b>	0.57	<b>0.75</b>	386	<b>851</b>	None/ BOCE
326F 330F 335F	CB	Pin-On/ Pin Grabber	General Duty	600-1350	<b>24-54</b>	0.63-1.83	<b>0.83-2.40</b>	704-1118	<b>1552-2464</b>	K90
			General Duty Wide Tip	600-1350	<b>24-54</b>	0.63-1.83	<b>0.83-2.40</b>	729-1176	<b>1607-2592</b>	K90
			Heavy Duty	600-1650	<b>24-66</b>	0.52-1.97	<b>0.68-2.58</b>	734-1290	<b>1619-2844</b>	K100
			Heavy Duty Power	1050-1350	<b>42-54</b>	1.12-1.53	<b>1.47-2.01</b>	1006-1176	<b>2218-2592</b>	K100
			Severe Duty	600-1200	<b>24-48</b>	0.52-1.33	<b>0.68-1.74</b>	781-1130	<b>1721-2491</b>	K100
			Cleanup	1800	<b>72</b>	1.81	<b>2.37</b>	1196	<b>2527</b>	BOCE
			Ditch Cleaning	1500-1800	<b>60-72</b>	1.25-1.53	<b>1.63-2.00</b>	793-897	<b>1627-1973</b>	BOCE
			Ditch Cleaning Tilt	1800	<b>72</b>	1.14	<b>1.50</b>	1531	<b>3374</b>	BOCE
			Center-Lock Pin Grabber Performance	Heavy Duty	750-1500	<b>30-60</b>	0.70-1.69	<b>0.91-2.21</b>	839-1311	<b>1849-2890</b>
		Severe Duty	600-1200	<b>24-48</b>	0.51-1.28	<b>0.66-1.68</b>	794-1207	<b>1750-2661</b>	K100	
		Dedicated	General Purpose	1350	<b>54</b>	1.83	<b>2.40</b>	1156	<b>2549</b>	K90
Heavy Duty	900-1350	<b>36-54</b>	0.93-1.57	<b>1.22-2.05</b>	924-1161	<b>2037-2560</b>	K100			
Ditch Cleaning	1800	<b>72</b>	1.53	<b>2.00</b>	897	<b>1978</b>	BOCE			
336E 336F	DB	Pin-On/ Pin Grabber	General Duty	750-1650	<b>30-66</b>	0.94-2.55	<b>1.23-3.33</b>	924-1470	<b>2037-3240</b>	K100
			General Duty Wide Tip	800-1550	<b>32-62</b>	1.18-2.27	<b>1.54-2.98</b>	1042-1463	<b>2298-3225</b>	K100
			Heavy Duty	750-1800	<b>30-72</b>	0.73-2.36	<b>0.95-3.08</b>	995-1767	<b>2194-3896</b>	K110
			Heavy Duty Power	900-1500	<b>36-60</b>	0.95-1.86	<b>1.24-2.43</b>	1123-1561	<b>2476-3441</b>	K110
			Severe Duty	750-1350	<b>30-54</b>	0.73-1.64	<b>0.95-2.14</b>	1060-1539	<b>2336-3393</b>	K110
			Extreme Duty	1200	<b>48</b>	1.40	<b>1.84</b>	1596	<b>3519</b>	K110
			Cleanup	1800	<b>72</b>	2.48	<b>3.24</b>	1444	<b>3184</b>	BOCE
			Ditch Cleaning	1500-1800	<b>60-72</b>	1.63-1.91	<b>2.13-2.50</b>	1088-1216	<b>2394-2677</b>	BOCE
			Center-Lock Pin Grabber Performance	Heavy Duty	900-1650	<b>36-66</b>	0.87-1.93	<b>1.14-2.52</b>	1158-1728	<b>2553-3809</b>
		Severe Duty	750-1350	<b>30-54</b>	0.68-1.50	<b>0.88-1.97</b>	1063-1588	<b>2344-3501</b>	K110	
		Dedicated	General Purpose	1500	<b>60</b>	2.27	<b>2.98</b>	1394	<b>3073</b>	K100
Heavy Duty	750-1500	<b>30-60</b>	0.74-1.87	<b>0.96-2.45</b>	965-1538	<b>2128-3391</b>	K110			
Cleanup	1800-2100	<b>72-83</b>	2.48-2.91	<b>3.24-3.81</b>	1416-1567	<b>3122-3455</b>	BOCE			
Ditch Cleaning	1800	<b>72</b>	1.91	<b>2.50</b>	1175	<b>2590</b>	BOCE			

7

Model	Bucket Family	Interface	Bucket Type	Width Range		Capacity Range		Weight Range		GET
				mm	in	m <sup>3</sup>	yd <sup>3</sup>	kg	lb	
<b>336E 336F 349E 349F</b>	TB	Pin-On/ Pin Grabber	General Duty	750-1850	<b>30-74</b>	0.95-3.08	<b>1.24-4.04</b>	1275-2170	<b>2811-4784</b>	K110
			General Duty High Capacity	2000	<b>80</b>	3.82	<b>5.00</b>	2373	<b>5232</b>	K110
			General Duty Wide Tip	900-1950	<b>36-78</b>	1.35-3.41	<b>1.77-4.46</b>	1457-2420	<b>3212-5335</b>	K110
			Heavy Duty	900-1800	<b>36-72</b>	1.08-2.69	<b>1.41-3.52</b>	1546-2339	<b>3409-5156</b>	K110
			Severe Duty	750-1850	<b>30-74</b>	0.88-2.69	<b>1.15-3.52</b>	1410-2612	<b>3109-5759</b>	K130
			Extreme Duty	1250-1400	<b>49-55</b>	1.60-1.87	<b>2.09-2.44</b>	2148-2290	<b>4735-5048</b>	K130
		Center-Lock Pin Grabber Performance	Heavy Duty	1200-1850	<b>48-74</b>	1.49-2.56	<b>1.95-3.34</b>	1870-2501	<b>4122-5514</b>	K110
<b>349E 349F</b>	UB	Pin-On/ Pin Grabber	Heavy Duty	1650-1950	<b>65-77</b>	2.77-3.43	<b>3.62-4.48</b>	2486-2803	<b>5481-6180</b>	K130
			Severe Duty	1450-1850	<b>58-73</b>	2.39-3.21	<b>3.13-4.20</b>	2464-2892	<b>5432-6375</b>	K130
<b>374D 374F</b>	VB2	Pin-On/ Pin Grabber	General Duty	1900	<b>75</b>	3.80	<b>5.00</b>	3565	<b>7859</b>	K150
			General Duty High Capacity	2000	<b>79</b>	4.60	<b>6.00</b>	3922	<b>8646</b>	K150
			Heavy Duty	1220-1900	<b>48-75</b>	2.20-3.80	<b>2.90-5.00</b>	2799-3726	<b>6170-8214</b>	K150
			Severe Duty	1100-1900	<b>43-75</b>	1.90-3.80	<b>2.50-5.00</b>	2747-3861	<b>6056-8512</b>	K150
			Extreme Duty	1900	<b>75</b>	3.80	<b>5.00</b>	4682	<b>10,322</b>	K150
<b>374D 374F</b>	WB2	Pin-On/ Pin Grabber	Severe Duty	1900-2000	<b>75-79</b>	4.00-4.40	<b>5.25-5.75</b>	4661-4818	<b>10,276- 10,622</b>	K170
			Extreme Duty	2000-2100	<b>79-83</b>	4.40-4.60	<b>5.70-6.00</b>	5787-6060	<b>12,758- 13,360</b>	K170
<b>390D 390F</b>	HB2	Pin-On/ Pin Grabber	General Duty	1350-1900	<b>54-75</b>	3.00-4.60	<b>4.00-6.00</b>	3282-4000	<b>7236-8818</b>	K150
			General Duty High Capacity	2000	<b>79</b>	5.30	<b>7.00</b>	4245	<b>9359</b>	K150
			Severe Duty	1100-1910	<b>43-75</b>	2.30-4.60	<b>3.00-6.00</b>	3189-4398	<b>7030-9696</b>	K150
<b>390D 390F</b>	JC	Pin-On/ Pin Grabber	General Duty	2300-2420	<b>91-95</b>	5.70-6.00	<b>7.40-7.90</b>	5576-5758	<b>12,293- 12,694</b>	K170
			General Duty High Capacity	2575	<b>101</b>	6.50	<b>8.50</b>	5992	<b>13,210</b>	K170
			Severe Duty	1960-2440	<b>77-96</b>	4.60-6.00	<b>6.00-7.90</b>	5858-6878	<b>12,915- 15,163</b>	J800
			Extreme Duty	2090	<b>82</b>	5.00	<b>6.50</b>	7353-7455	<b>16,221- 16,435</b>	J800

Model	Bucket Family	Interface	Bucket Type	Width Range		Capacity Range		Weight Range		GET
				mm	in	m <sup>3</sup>	yd <sup>3</sup>	kg	lb	
312D2	312	Pin-On/ Pin Grabber	General Duty Severe Duty	1200	48	0.76	1.00	487	1074	J250
				900-1050	36-42	0.53-0.65	0.69-0.84	456-502	1005-1106	J300
318D2 M315D2 M317D2	315	Pin-On/ Pin Grabber	General Duty Severe Duty	1200	48	0.91	1.19	625	1378	K80
				1200	48	0.91	1.19	730	1609	K90
320D2 M322D2	B	Pin-On/ Pin Grabber	Heavy Duty	1050-1350	42-54	1.00-1.40	1.31-1.83	846-978	1866-2156	K90
323D2	B	Pin-On/ Pin Grabber	Heavy Duty	1200-1350	48-54	1.19-1.40	1.56-1.83	891-978	1965-2156	K90
323D2	CB	Pin-On	Severe Duty Power	1350	54	1.56	2.04	1256	2770	K100
		Dedicated	Severe Duty	1350	54	1.56	2.04	1208	2664	K100
326D2 330D2	CB	Pin-On/ Pin Grabber	Heavy Duty	1500	60	1.76	2.30	1181	2605	K100
330D2	DB	Pin-On	Severe Duty	1350-1650	54-66	1.66-2.15	2.17-2.81	1528-1767	3368-3896	K100
		Dedicated	Severe Duty	1500-1650	60-66	1.90-2.15	2.50-2.81	1613-1741	3556-3838	K110
336D2	DB	Pin-On/ Pin Grabber	Heavy Duty	1650	66	2.12	2.77	1613	3556	K110
			Severe Duty	1350-1650	54-66	1.66-2.15	2.17-2.81	1528-1767	3368-3896	K110
336D2	TB	Pin-On	Heavy Duty	1800	72	2.69	3.52	2320	5115	K110
			Severe Duty	1550	61	2.14	2.80	2264	4491	K130
			Severe Duty Power	1750	70	2.40	3.14	2378	5243	K110
			Extreme Duty Power	1550	61	2.00	2.59	2440	5379	K130
		Dedicated	Severe Duty	1650	66	2.41	3.16	2235	4927	K110
349D2	TB	Pin-On/ Pin Grabber	Heavy Duty	1800	72	2.69	3.52	2320	5115	K110
			Severe Duty	1550	61	2.14	2.80	2264	4491	K130
			Severe Duty Power	1750	70	2.40	3.14	2378	5243	K110
			Extreme Duty Power	1550	61	2.00	2.59	2440	5379	K130
349D2-ME	UB	Pin-On	Severe Duty	1850	73	3.21	4.20	2892	6375	K130
			Extreme Duty	1550	62	2.61	3.41	3066	6759	K130
		Dedicated	Severe Duty	1650	65	2.77	3.62	2579	5986	K130
			Extreme Duty	1550	62	2.61	3.41	3011	6638	K130
374F	WB2	Pin-On	Severe Duty	1800-2200	71-87	3.70-5.00	4.80-6.50	4503-5136	9927-11,323	K170
			Extreme Duty	1900-2100	75-83	4.00-4.60	5.25-6.00	5423-5818	11,956-12,826	K170
		Dedicated	Severe Duty	1900-2000	75-79	4.00-4.40	5.25-5.75	4638-4795	10,225-10,571	K170
			Extreme Duty	2000	79	4.40	5.75	5633	12,419	K170
390F	HB2	Pin-On	General Duty	1100-2000	43-79	2.20-4.60	2.80-6.00	2763-3908	6091-8616	K150
390F	JC	Pin-On	General Duty	2300-2420	91-95	5.70-6.00	7.40-7.90	5576-5758	12,293-12,694	K170
			Heavy Duty	1750	69	4.10	5.30	4635	10,218	K170
			Severe Duty	2240-2440	88-96	5.40-6.00	7.10-7.90	6438-6878	14,193-15,163	J800
		Extreme Duty	2090-2240	82-88	5.00-5.40	6.50-7.10	6186-7362	13,638-16,230	J800	
		Dedicated	Severe Duty	2240	88	5.40	7.10	6188	13,642	J800

7

ME = Mass Excavation

Model	Bucket Family	Interface	Bucket Type	Width Range		Capacity Range		Weight Range		GET
				mm	in	m <sup>3</sup>	yd <sup>3</sup>	kg	lb	
311F 312D2 312E 314E	312	Pin-On	General Duty	600-1200	<b>24-48</b>	0.31-0.76	<b>0.41-0.99</b>	305-479	<b>305-1056</b>	J250
			Heavy Duty	450-1200	<b>18-48</b>	0.20-0.76	<b>0.26-0.99</b>	266-486	<b>586-1071</b>	J250
			Severe Duty	900	<b>36</b>	0.53	<b>0.69</b>	444	<b>979</b>	J300
		CW Dedicated	General Duty	600-1200	<b>24-48</b>	0.31-0.76	<b>0.41-0.99</b>	330-491	<b>728-1082</b>	J250
			Heavy Duty	500-1200	<b>20-48</b>	0.24-0.76	<b>0.31-0.99</b>	309-501	<b>681-1105</b>	J250
316E 318D2	315	Pin-On	General Duty	1100-1400	<b>43-55</b>	0.80	<b>1.05</b>	580-686	<b>1279-1512</b>	K80
			Severe Duty	1200	<b>48</b>	0.91	<b>1.19</b>	701	<b>1545</b>	K90
		CW Dedicated	General Duty	600-1400	<b>24-55</b>	0.35-1.09	<b>0.46-1.43</b>	415-667	<b>915-1470</b>	K80
			Heavy Duty	1200-1400	<b>48-55</b>	0.91-1.09	<b>1.19-1.43</b>	623-686	<b>1373-1512</b>	K80
M315D2	M313	Pin-On	General Duty	450-1210	<b>18-48</b>	0.20-0.76	<b>0.27-1.00</b>	292-500	<b>644-1102</b>	J250
			Heavy Duty	1200	<b>48</b>	0.76	<b>1.00</b>	509	<b>1122</b>	J250
		CW Dedicated	General Duty	450-1200	<b>18-48</b>	0.20-0.76	<b>0.27-1.00</b>	330-491	<b>290-1082</b>	J250
			Heavy Duty	500-1200	<b>20-48</b>	0.24-0.76	<b>0.31-1.00</b>	309-501	<b>681-1105</b>	J250
M317D2	M316	Pin-On	General Duty	750-1400	<b>30-55</b>	0.49-1.09	<b>0.64-1.43</b>	466-686	<b>1027-1512</b>	K80
			Heavy Duty	1300	<b>51</b>	1.00	<b>1.31</b>	673	<b>1484</b>	K80
		CW Dedicated	General Duty	600-1400	<b>24-55</b>	0.35-1.09	<b>0.46-1.43</b>	415-667	<b>915-1470</b>	K80
			Heavy Duty	1200-1400	<b>48-55</b>	0.91-1.09	<b>1.18-1.43</b>	623-686	<b>1374-1512</b>	K80
318E	318E	Pin-On	General Duty	600-1400	<b>24-55</b>	0.35-1.09	<b>0.46-1.43</b>	434-713	<b>957-1572</b>	K80
			Heavy Duty	1300	<b>51</b>	1.00	<b>1.31</b>	697	<b>1537</b>	K80
		CW Dedicated	General Duty	600-1400	<b>24-55</b>	0.35-1.09	<b>0.46-1.43</b>	415-667	<b>915-1470</b>	K80
			Heavy Duty	1200-1400	<b>48-55</b>	0.91-1.09	<b>1.18-1.43</b>	623-686	<b>1374-1512</b>	K80
318D 319D M320D2	318	Pin-On	General Duty	600-1400	<b>24-55</b>	0.24-1.13	<b>0.31-1.48</b>	465-723	<b>1025-1594</b>	K80
			Heavy Duty	1200-1400	<b>48-55</b>	0.94-1.13	<b>1.23-1.48</b>	691-757	<b>1523-1669</b>	K80
		CW Dedicated	General Duty	600-1400	<b>24-55</b>	0.35-1.09	<b>0.46-1.43</b>	415-667	<b>915-1470</b>	K80
			Heavy Duty	1200-1300	<b>48-51</b>	0.91-1.09	<b>1.19-1.43</b>	623-686	<b>1373-1512</b>	K80
320D2 320E 320E RR 323D2 323E 325F M322D2	B	Pin-On	General Duty	600-1400	<b>24-55</b>	0.46-1.43	<b>0.60-1.87</b>	533-841	<b>1175-1854</b>	K80
			Heavy Duty	1200-1400	<b>48-55</b>	1.19-1.30	<b>1.58-1.70</b>	880-928	<b>1940-2046</b>	K90
			Severe Duty	1200	<b>48</b>	1.20	<b>1.57</b>	974	<b>2147</b>	K90
		CW Dedicated	General Duty	900-1300	<b>36-51</b>	0.81-1.30	<b>1.06-1.70</b>	634-775	<b>1398-1709</b>	K80
			Heavy Duty	600-1300	<b>24-51</b>	0.46-1.30	<b>0.60-1.70</b>	591-897	<b>1303-1978</b>	K90
			Severe Duty	1200	<b>48</b>	1.20	<b>1.57</b>	958	<b>2112</b>	K90

Model	Bucket Family	Interface	Bucket Type	Width Range		Capacity Range		Weight Range		GET		
				mm	in	m <sup>3</sup>	yd <sup>3</sup>	kg	lb			
323D2 326D2 326F 330D2 330F 335F	CB	Pin-On	General Duty	750-1500	<b>30-60</b>	0.71-1.76	<b>0.92-2.30</b>	711-1041	<b>1567-2295</b>	K90		
			Heavy Duty	1350-1500	<b>54-60</b>	1.54-1.76	<b>2.01-2.30</b>	1096-1181	<b>2416-2603</b>	K100		
			Severe Duty	1350	<b>54</b>	1.56	<b>2.04</b>	1207	<b>2661</b>	K100		
		CW Dedicated	General Duty	750-1650	<b>30-66</b>	0.71-1.97	<b>0.92-2.58</b>	614-1058	<b>1354-2332</b>	K90		
			Heavy Duty	750-1650	<b>30-66</b>	0.71-1.97	<b>0.92-2.58</b>	707-1253	<b>1559-2762</b>	K100		
			Severe Duty	1050-1350	<b>42-54</b>	1.13-1.56	<b>1.23-2.04</b>	947-1115	<b>2088-2458</b>	K100		
330D2 336E 340D	DB	Pin-On	General Duty	1350-1800	<b>54-72</b>	1.64-2.36	<b>2.15-3.09</b>	1135-1396	<b>2502-3078</b>	K100		
			Heavy Duty	1350-1650	<b>54-66</b>	1.64-2.12	<b>2.15-2.78</b>	1399-1613	<b>3084-3556</b>	K110		
			Severe Duty	1350-1650	<b>54-66</b>	1.66-2.15	<b>2.17-2.81</b>	1528-1767	<b>3368-3896</b>	K110		
		CW Dedicated	General Duty	1350-1650	<b>54-66</b>	1.64-2.12	<b>2.15-2.78</b>	948-1276	<b>2090-2813</b>	K100		
			Heavy Duty	750-1800	<b>30-72</b>	0.73-2.36	<b>0.96-3.09</b>	937-1686	<b>2066-3717</b>	K110		
			Severe Duty	1050-1650	<b>42-66</b>	1.17-2.15	<b>1.53-2.81</b>	1236-1742	<b>2725-3840</b>	K110		
336D 336E 340D	TB	Pin-On	General Duty	1500-1650	<b>60-66</b>	2.14-2.41	<b>2.80-3.15</b>	1824-1967	<b>4021-4336</b>	K110		
			Heavy Duty	1650-1800	<b>66-72</b>	2.41-2.69	<b>3.15-3.52</b>	2150-2284	<b>4740-5035</b>	K110		
			Severe Duty	1350-1650	<b>54-66</b>	1.87-2.41	<b>2.45-3.15</b>	2017-2325	<b>4447-5126</b>	K110		
		CW Dedicated	General Duty	1650	<b>66</b>	2.41	<b>3.15</b>	2059	<b>4539</b>	K110		
			Heavy Duty	1350-1650	<b>54-66</b>	1.87-2.41	<b>2.45-3.15</b>	1926-2235	<b>4246-4927</b>	K110		
			Severe Duty	1350-1650	<b>54-66</b>	1.87-2.41	<b>2.45-3.15</b>	1926-2235	<b>4246-4927</b>	K110		
349E	TB	Pin-On	General Duty	1350	<b>54</b>	1.87	<b>2.45</b>	1707	<b>3763</b>	K110		
			Heavy Duty	1500-1850	<b>60-74</b>	2.14-2.78	<b>2.80-3.64</b>	2017-2348	<b>4447-5176</b>	K110		
			Severe Duty	1550-1900	<b>62-75</b>	2.14-2.78	<b>2.80-3.64</b>	2264-2621	<b>4991-5778</b>	K130		
		CW Dedicated	Heavy Duty	1650	<b>66</b>	2.41	<b>3.15</b>	2136	<b>4709</b>	K110		
			Severe Duty	1650	<b>66</b>	2.41	<b>3.15</b>	2136	<b>4709</b>	K110		
			Extreme Duty	1650	<b>66</b>	2.41	<b>3.15</b>	2136	<b>4709</b>	K110		
349D2 349E	UB	Pin-On	General Duty	1450-2000	<b>56-79</b>	2.39-3.60	<b>3.13-4.71</b>	2248-2786	<b>4956-6142</b>	K130		
			Heavy Duty	1650-1950	<b>66-78</b>	2.77-3.43	<b>3.63-4.49</b>	2486-2803	<b>5481-6180</b>	K130		
			Severe Duty	1450-1950	<b>56-78</b>	2.39-3.43	<b>3.13-4.49</b>	2464-2963	<b>5432-6532</b>	K130		
			Extreme Duty	1550-1650	<b>62-66</b>	2.61-2.77	<b>3.42-3.63</b>	3015-3116	<b>6647-6870</b>	K130		
		CW Dedicated	Heavy Duty	1650-1850	<b>66-74</b>	2.77-3.21	<b>3.63-4.20</b>	2403-2568	<b>5298-5661</b>	K130		
			Severe Duty	1550-1650	<b>62-66</b>	2.61-2.77	<b>3.42-3.63</b>	2494-2579	<b>5498-5686</b>	K130		
374D	VB2	Pin-On	General Duty	1900	<b>75</b>	3.80	<b>5.00</b>	3498	<b>7711</b>	K150		
			Heavy Duty	1900	<b>75</b>	3.80	<b>5.00</b>	3658	<b>8064</b>	K150		
374D	WB2	Pin-On	General Duty	2000-2100	<b>79-83</b>	4.60-5.00	<b>6.00-6.50</b>	3892-4012	<b>8580-8845</b>	K150		
			Heavy Duty	2100-2250	<b>83-89</b>	5.00-5.30	<b>6.50-7.00</b>	4190-4436	<b>9237-9780</b>	K150		
			Severe Duty	1800-2200	<b>71-87</b>	3.70-5.00	<b>4.80-6.50</b>	4503-5136	<b>9927-11,323</b>	K170		
			Extreme Duty	1900-2200	<b>75-87</b>	4.00-5.00	<b>5.38-6.41</b>	5423-6007	<b>11,956-13,243</b>	K170		
		CW Dedicated	Severe Duty	1900-2000	<b>75-79</b>	4.00-4.40	<b>5.25-5.75</b>	4638-4795	<b>10,225-10,571</b>	K170		
			Extreme Duty	2000	<b>79</b>	4.40	<b>5.75</b>	5633	<b>12,419</b>	K170		
390D	HB2	Pin-On	General Duty	1100-2200	<b>43-87</b>	2.20-6.00	<b>2.80-8.00</b>	2763-4610	<b>6091-10,163</b>	K170		
			JC	Pin-On	General Duty	2300-2420	<b>91-95</b>	5.70-6.00	<b>7.40-7.90</b>	5576-5758	<b>12,293-12,694</b>	K170
					Heavy Duty	1750	<b>69</b>	4.10	<b>5.30</b>	4635	<b>10,218</b>	K170
	Severe Duty	2240-2440			<b>88-96</b>	5.40-6.00	<b>7.10-7.90</b>	6438-6878	<b>14,193-15,163</b>	J800		
	CW Dedicated	Severe Duty	Extreme Duty	2090-2350	<b>82-93</b>	5.00-5.70	<b>6.50-7.50</b>	6186-7595	<b>13,638-16,744</b>	J800		
			Severe Duty	2150-2350	<b>84-93</b>	5.00-5.70	<b>6.50-7.50</b>	5872-6394	<b>12,946-14,096</b>	J800		

Model	Bucket Family	Interface	Bucket Type	Width Range		Capacity Range		Weight Range		GET
				mm	in	m <sup>3</sup>	yd <sup>3</sup>	kg	lb	
311F 312D2 312E 314E	312	Pin-On/ Pin Grabber	General Duty	458-1067	<b>18-42</b>	0.25-0.65	<b>0.33-0.85</b>	259-460	<b>571-2368</b>	J250/ K80 BOCE
			Ditch Cleaning	1500	<b>59</b>	0.97	<b>1.27</b>	565	<b>1246</b>	
316E M314F M316F M318F	315	Pin-On/ Pin Grabber	General Duty	617-1200	<b>24-48</b>	0.35-0.91	<b>0.45-1.19</b>	388-619	<b>855-1365</b>	K80
			Severe Duty	1050	<b>42</b>	0.76	<b>1.00</b>	666	<b>1469</b>	J350
			Ditch Cleaning	1500-1677	<b>59-66</b>	0.88-1.26	<b>1.15-1.38</b>	608-614	<b>1340-1354</b>	BOCE
318E M320F	B	Pin-On/ Pin Grabber	Heavy Duty	616-1230	<b>24-48</b>	0.44-1.07	<b>0.57-1.40</b>	595-850	<b>1312-1873</b>	K90
			General Duty	1050-1200	<b>42-48</b>	0.76-0.91	<b>1.00-1.19</b>	584-640	<b>1287-1411</b>	K80
320F 325F	B	Pin-On/ Pin Grabber	General Duty	600-1500	<b>24-60</b>	0.46-1.58	<b>0.61-2.05</b>	529-877	<b>1166-1933</b>	K80/ J350
			Heavy Duty	610-1500	<b>24-60</b>	0.46-1.58	<b>0.61-2.06</b>	609-1031	<b>1342-2273</b>	K90/ J350
			Severe Duty	600-1250	<b>24-49</b>	0.46-1.20	<b>0.61-1.57</b>	674-1012	<b>1485-2230</b>	K90/ J400
			Ditch Cleaning	1830	<b>72</b>	1.25	<b>1.62</b>	854	<b>1883</b>	BOCE
323F 326F LR	A	Pin-On	Ditch Cleaning	1830	<b>72</b>	0.57	<b>0.75</b>	289	<b>637</b>	none
326F 330F	CB	Pin-On/ Pin Grabber	General Duty	600-1500	<b>24-60</b>	0.52-1.76	<b>0.68-2.30</b>	639-1041	<b>1409-2295</b>	K90
			Heavy Duty	610-1676	<b>24-66</b>	0.53-1.99	<b>0.69-2.60</b>	770-1340	<b>1698-2954</b>	K100
			Severe Duty	1067	<b>66</b>	1.14	<b>1.50</b>	1111	<b>2450</b>	K100
			Ditch Cleaning	1830	<b>72</b>	1.53	<b>2.00</b>	983	<b>2167</b>	BOCE
336E 340D	DB	Pin-On/ Pin Grabber	Heavy Duty	762-1829	<b>30-72</b>	0.74-2.34	<b>0.97-3.06</b>	1020-1806	<b>2250-3982</b>	K110/ K100
			Severe Duty	1219	<b>48</b>	1.41	<b>1.84</b>	1511	<b>3331</b>	K110
			Ditch Cleaning	1830	<b>72</b>	1.91	<b>2.49</b>	1178	<b>2597</b>	BOCE
336E 340D 349D2 349E	TB	Pin-On/ Pin Grabber	Heavy Duty	914-1880	<b>36-74</b>	1.06-2.68	<b>1.38-3.50</b>	1512-2360	<b>3333-5203</b>	K110
			Severe Duty	1372	<b>54</b>	1.81	<b>2.37</b>	2024	<b>4462</b>	K130
349D2 349E-ME	UB	Pin-On/ Pin Grabber	General Duty	1981	<b>78</b>	3.47	<b>4.5</b>	2762	<b>5891</b>	K130

ME = Mass Excavation

Model	Bucket Family	Interface	Bucket Type	Width Range		Capacity Range		Weight Range		GET
				mm	in	m <sup>3</sup>	yd <sup>3</sup>	kg	lb	
374D	VB2	Pin-On/ Pin Grabber	General Duty	1525	60	2.9	3.9	3081	6792	K150
			Severe Duty	1700	66	3.3	4.3	3529	7780	K150
374D	WB2	Pin-On	Severe Duty	2100	83	4.6	6.0	4977	10,972	K170
			Extreme Duty	2050-2150	80-85	4.4-4.6	5.75-6.0	5671-5818	12,502-12,826	K170
		CW Dedicated	Severe Duty	1900-2000	75-79	4.0-4.4	5.25-5.75	4638-4795	10,225-10,571	K170
			Extreme Duty	2000	79	4.4	5.75	5633	12,419	K170
390D	HB2	Pin-On	General Duty	1685-1910	66-75	3.9-4.6	5.1-6.0	3670-4000	8091-8818	K150
390D	JC	Pin-On	General Duty	2420	95	6.0	7.9	5752	12,681	K170
			Heavy Duty	2090-2300	82-91	5.1-5.7	6.6-7.4	5236-5646	11,543-12,447	K170
			Severe Duty	2240	88	5.4	7.1	6440	14,198	J800
			Extreme Duty	2090-2240	82-88	5.0-5.4	6.5-7.1	6186-7362	13,638-16,230	J800
		CW Dedicated	Severe Duty	2240-2350	88-93	5.4-5.7	7.1-7.50	6188-6394	13,642-14,096	J800



Model	Bucket Family	Interface	Bucket Type	Width Range		Capacity Range		Weight Range		GET
				mm	in	m <sup>3</sup>	yd <sup>3</sup>	kg	lb	
312D2 GC 313D2	312	Pin-On	Utility Duty	911	36	0.53	0.69	423	932	J250
			General Duty	1085	43	0.65	0.84	493	1087	J250
			Severe Duty	1087	43	0.65	0.84	559	1232	J300
318D2	315	Pin-On	General Duty	1100	43	0.80	1.04	598	1318	J300
			Severe Duty	1050	42	0.76	1.00	666	1496	J350
320D2 323D2	B	Pin-On	Utility Duty	1121-1274	44-50	0.80-1.00	1.04-1.31	736-853	1622-1881	J350
			General Duty	1279-1419	50-56	1.00-1.14	1.31-1.49	816-882	1800-1944	J350
			Heavy Duty	1096-1400	43-55	1.00-1.34	1.31-1.75	928-1052	2046-2319	J350
			Severe Duty	1093-1244	43-49	1.00-1.19	1.31-1.56	1043-1142	2300-2518	J400
323D2	CB	Pin-On	Severe Duty	1244	49	1.19	1.56	1142	2518	J460
			Extreme Duty	1250	49	1.33	1.74	1320	2910	J460
326D2 330D2	CB	Pin-On	General Duty	1400	55	1.54	2.02	1058	2333	J400
			Heavy Duty	1250-1400	49-55	1.33-1.54	1.74-2.02	1072-1163	2363-2564	J400
			Severe Duty	1252-1400	50-56	1.33-1.54	1.74-2.02	1197-1307	2639-2882	J460
336D 340D	DB	Pin-On	Heavy Duty	1395-1547	55-61	1.64-1.88	2.14-2.46	1528-1621	3369-3574	J460
			Severe Duty	1413-1570	56-62	1.64-1.90	2.14-2.46	1766-1910	3893-4211	J550
			Extreme Duty	1413	56	1.64	2.14	1852	4083	J550
336E 340D	TB	Pin-On	General Duty	1500	60	2.14	2.80	1900	4189	J550
			Heavy Duty	1734-1850	68-73	2.12-2.69	2.77-3.52	1715-2543	3781-5606	J550
			Severe Duty	1570-1722	62-68	2.14-2.41	2.80-3.16	2290-2541	5050-6690	J550
349D2	TB	Pin-On	General Duty	1650	66	2.41	3.16	2198	4846	J550
			Severe Duty	1570-1864	62-73	2.14-3.21	2.09-3.16	2290-3034	5050-6690	J550
349D2-ME	UB	Pin-On	General Duty	1550	62	2.61	3.41	2272	5009	J550
			Severe Duty	1589-1864	63-73	2.61-3.21	3.41-4.20	2701-3034	5955-6690	J550
374D	VB2	Pin-On	General Duty	1525	60	2.90	3.90	3081	6792	K150
			Severe Duty	1700	66	3.30	4.30	3529	7780	K150
374D	WB2	Pin-On	Severe Duty	2220	87	4.60	6.00	5316	11,720	K170/ J700
			Extreme Duty	2220-2300	87-91	4.40-4.60	5.75-6.00	5868-6028	12,937-13,289	K170
390D	HB2	Pin-On	General Duty	1650-1900	66-75	3.90-4.60	5.10-6.00	3670-4000	8091-8818	K150
390D	JC	Pin-On	General Duty	2300-2420	91-95	5.70-6.00	7.40-7.90	5576-5758	12,293-12,694	K170
			Heavy Duty	2090-2300	82-91	5.10-5.70	6.60-7.40	5236-5646	11,543-12,447	K170
			Severe Duty	2040-2510	80-99	4.60-6.00	6.00-7.90	6329-7442	13,953-16,410	J800
	CW Dedicated	Severe Duty	2240-2350	88-93	5.40-5.70	7.10-7.50	6188-6394	13,642-14,096	J800	

ME = Mass Excavation

## EXCAVATOR BUCKET CAPACITIES

Caterpillar rates excavator buckets to conform with both PCSA standard No. 3 and SAE standard J-296. Buckets are rated on both their struck and heaped capacities as follows:

### Struck Capacity

Volume actually enclosed inside the outline of the sideplates and rear and front bucket enclosures without any consideration for any material supported or carried by the spillplate or bucket teeth.

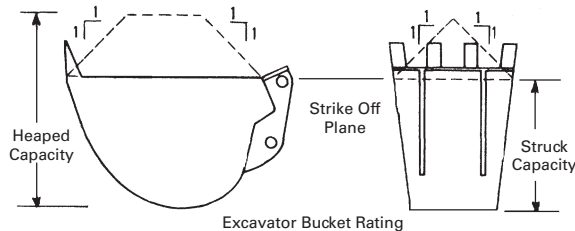

### Heaped Capacity

Volume in the bucket under the strike off plane plus the volume of the heaped material above the strike off plane, having an angle of repose of 1:1 without any consideration for any material supported or carried by the spillplate or bucket teeth.

The Committee on European Construction Equipment (CECE) rates heaped bucket pay loads on a 2:1 angle of repose for material above the strike off plane.

## CURL AND CROWD FORCES

Bucket penetration into a material is achieved by the bucket curling force ( $F_B$ ) and stick crowd force ( $F_S$ ). Rated digging forces are the digging forces that can be exerted at the outermost cutting point. These forces can be calculated by applying working relief hydraulic pressure to the cylinder(s) providing the digging force. The digging forces listed on next page conform with SAE Standard J1179 and PCSA Standard No. 3. The values may not be directly comparable to forces for machines rated by other methods than those described below.

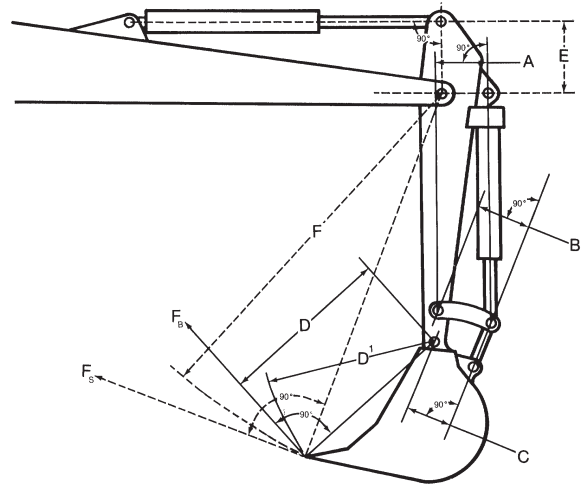

$$F_B = \text{Radial tooth force due to bucket cylinder} \\ = \frac{\text{Bucket cylinder force}}{\text{Arm D length}} \left( \frac{\text{Arm A} \times \text{Arm C}}{\text{Arm B}} \right)$$

$$\text{Cylinder force} = (\text{Pressure}) \times (\text{End area of cylinder head}) \\ \text{Arm D} = \text{Bucket tip radius}$$

Maximum radial tooth force due to bucket cylinder (bucket curling force) is the digging force generated by the bucket cylinder(s) and tangent to the arc of radius  $D'$ . The bucket shall be positioned to obtain maximum output moment from the bucket cylinder(s) and connecting linkages. When calculating, maximum  $F_B$  occurs when the factor — Arm A times Arm C divided by Arm B — becomes the maximum.

$$F_S = \text{Radial tooth force due to stick cylinder} \\ = \frac{(\text{Stick cylinder force}) \times (\text{Arm E length})}{(\text{Arm F length})}$$

$$\text{Arm F} = \text{Bucket tip radius} + \text{stick length}$$

Maximum radial tooth force due to stick cylinder (stick crowd force) is the digging force generated by the stick cylinder(s) and tangent to the arc of radius F. The stick shall be positioned to obtain the maximum output moment from the arm cylinder and the bucket positioned as described in the bucket force rating. When calculating, maximum  $F_S$  occurs when the axis in the stick cylinder working direction is at a right angle to the line connecting the stick cylinder pin and the boom nose pin.

**Bucket Selection Considering  
Bucket Curl and Stick Crowd Forces**

The combination of the excavator's stick crowd force and bucket curling force give this machine configuration more effective bucket penetration force per mm (inch) of bucket cutting edge than is available with other machine types such as wheel and track loaders.

As a result of high penetration force, an excavator bucket is comparatively easy to load. Also, the higher unit breakout forces allow the excavator's economic application range to be extended farther into the tougher soils (coral, caliche, shale, limestone) before blasting or ripping is required.

To take full advantage of an excavator's high penetration forces, buckets should be selected so they are well matched to soil conditions that are encountered. The two important things to consider are bucket width and bucket tip radius.

As a general rule, wide buckets are used in easily dug soil and narrow buckets in harder material. In hard rocky soils, tip radius also has to be considered in bucket selection. Because the shorter tip radius buckets provide more total bucket curling force than the long tip radius buckets, they are generally the easiest to load. A good rule of thumb when selecting a Cat bucket for hard material is to choose the narrowest bucket that has a short tip radius.

Other factors such as trench bottom width specifications, manbox size, or the desire to conserve bedding material may also influence excavator bucket selection.

**NOTE: See the following pages for listing of Cat buckets by tip radius and cutting edge width.**

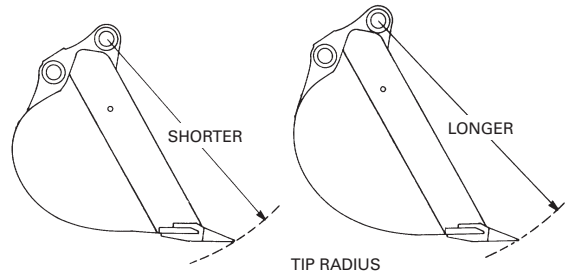

Model	Source	Bucket Tip Radius		Bucket Curling Forces		Stick Crowd Forces							
						Short		Medium		Long		Extra Long	
		mm	ft	kN	lb	kN	lb	kN	lb	kN	lb	kN	lb
300.9D	Austria	443	1'5"	8.9	2000	—	—	—	—	4.5	1011	—	—
301.4C	Austria	500	1'7"	15.4	3462	—	—	—	—	7.1	1596	—	—
301.7D	Austria	500	1'7"	18.8	4226	11.2	2518	—	—	9.8	2203	—	—
301.7D CR	Austria	500	1'7"	14.2	3190	8.4	1890	—	—	7.3	1640	—	—
302.2D	Austria	—	—	19.6	4406	12.6	2810	—	—	11.0	2473	—	—
302.4D	Austria	650	2'2"	21.8	4900	15.0	3372	—	—	13.3	2990	—	—
302.7D CR	Austria	650	2'1"	22.5	5058	—	—	15.4	3462	13.6	3057	—	—
303E CR	Japan	711	2'4"	28.4	6385	—	—	16.6	3732	—	—	—	—
303.5E CR	Japan	711	2'4"	33	7420	—	—	18.9	4250	16.9	3799	—	—
303.5E2 CR	United States	711	2'4"	33	7420	—	—	18.9	4250	16.9	3799	—	—
304E2 CR	United States	711	2'4"	37.8	8500	—	—	21.6	4860	19.5	4385	—	—
304.5E2 XTC	United States	711	2'4"	37.8	8500	—	—	21.6	4860	19.5	4385	—	—
305E2 CR	United States	786	2'7"	44.7	10,049	—	—	24.7	5553	21.3	4788	—	—
305.5E2 CR	United States	786	2'7"	50.9	11,443	—	—	28.9	6497	24.8	5575	—	—
307E2	China	1014	3'4"	50.6	11,375	—	—	37.1	8340	—	—	—	—
308E2 CR SB	United States	1014	3'3"	60	13,489	—	—	39	8768	—	—	—	—
308E2 VAB	United States	1014	3'3"	60	13,489	—	—	39	8768	—	—	—	—
311D LRR	Japan	1220	4'0"	90	20,175	—	—	60	13,560	55	12,270	52	11,690
312D, 312D L	Japan	1220	4'0"	85	19,100	—	—	64	14,400	60	13,500	57	12,800
312D, 312D L	France	1000	3'3"	96	21,600	66	14,850	62	13,950	59	13,275	—	—
313C SR	Japan	1220	4'0"	88	19,780	—	—	63	14,160	—	—	—	—
313C CR	Japan	1220	4'0"	94	21,120	—	—	64	14,380	57	12,810	—	—
314D CR, 314D LCR	Japan	1220	4'0"	85	19,100	—	—	64	14,400	60	13,500	57	12,800

**Japan Sourced  
315D L**

<b>Boom</b>		<b>1-Piece Boom</b>			
		<b>Short</b>	<b>Medium</b>	<b>Long</b>	<b>Extra Long</b>
<b>Stick</b>	<b>mm</b>	1350	1350	1350	1350
	<b>ft</b>	<b>4'5"</b>	<b>4'5"</b>	<b>4'5"</b>	<b>4'5"</b>
Bucket Tip Radius	<b>mm</b>	1350	1350	1350	1350
	<b>ft</b>	<b>4'5"</b>	<b>4'5"</b>	<b>4'5"</b>	<b>4'5"</b>
Bucket Curling Forces	<b>kN</b>	100	100	100	100
	<b>lb</b>	<b>22,530</b>	<b>22,530</b>	<b>22,530</b>	<b>22,530</b>
Stick Crowd Forces	<b>kN</b>	85	78	73	70
	<b>lb</b>	<b>19,200</b>	<b>17,470</b>	<b>16,410</b>	<b>15,670</b>

**Japan Sourced  
315D L (EAME)**

<b>Boom</b>		<b>1-Piece Boom</b>			
		<b>Short</b>	<b>Medium</b>	<b>Long</b>	<b>Extra Long</b>
<b>Stick</b>	<b>mm</b>	1117	1117	1117	1117
	<b>ft</b>	<b>3'7"</b>	<b>3'7"</b>	<b>3'7"</b>	<b>3'7"</b>
Bucket Tip Radius	<b>mm</b>	1117	1117	1117	1117
	<b>ft</b>	<b>3'7"</b>	<b>3'7"</b>	<b>3'7"</b>	<b>3'7"</b>
Bucket Curling Forces	<b>kN</b>	102	90	82	74
	<b>lb</b>	<b>22,930</b>	<b>20,230</b>	<b>18,430</b>	<b>16,630</b>
Stick Crowd Forces	<b>kN</b>	98	80	69	62
	<b>lb</b>	<b>22,030</b>	<b>17,980</b>	<b>15,510</b>	<b>13,930</b>

**319D L, 319D LN**

<b>Boom</b>		<b>1-Piece Boom</b>			
		<b>Short</b>	<b>Medium</b>	<b>Long</b>	<b>Extra Long</b>
<b>Stick</b>	<b>mm</b>	1461	1461	1461	1461
	<b>ft</b>	<b>4'10"</b>	<b>4'10"</b>	<b>4'10"</b>	<b>4'10"</b>
Bucket Tip Radius	<b>mm</b>	1461	1461	1461	1461
	<b>ft</b>	<b>4'10"</b>	<b>4'10"</b>	<b>4'10"</b>	<b>4'10"</b>
Bucket Curling Forces	<b>kN</b>	148	146	124	126
	<b>lb</b>	<b>33,300</b>	<b>32,850</b>	<b>27,900</b>	<b>28,350</b>
Stick Crowd Forces	<b>kN</b>	125	108	92	83
	<b>lb</b>	<b>28,125</b>	<b>24,300</b>	<b>20,700</b>	<b>18,675</b>

- Curl and Crowd Forces
- M314F ● M315D2 ● M316F ● M317D2 ● M318F
  - M320F ● M320D2 ● M322F ● M322D2

### M314F, M315D2

Boom		1-Piece/VA Boom			
Stick		2300 mm	7'5"	2600 mm	8'6"
Bucket Tip Radius	mm	1236		1236	
	ft	4'1"		4'1"	
Bucket Curling Forces	kN	93		93	
	lb	20,925		20,925	
Stick Crowd Forces	kN	67		62	
	lb	15,075		13,950	

### M316F, M317D2, M318F

Boom		1-Piece/VA Boom			
Stick		2400 mm	7'10"	2600 mm	8'6"
Bucket Tip Radius	mm	1405		1405	
	ft	4'7"		4'7"	
Bucket Curling Forces	kN	101		101	
	lb	22,725		22,725	
Stick Crowd Forces	kN	74		71	
	lb	16,650		15,975	

### M320F, M320D2

Boom		1-Piece/VA Boom			
Stick		2500 mm	8'2"	2800 mm	9'2"
Bucket Tip Radius	mm	1405		1405	
	ft	4'7"		4'7"	
Bucket Curling Forces	kN	126		126	
	lb	28,350		28,350	
Stick Crowd Forces	kN	91		85	
	lb	20,475		19,125	

### M322F, M322D2

Boom		1-Piece/VA Boom			
Stick		2500 mm	8'2"	2900 mm	9'6"
Bucket Tip Radius	mm	1511		1511	
	ft	4'11"		4'11"	
Bucket Curling Forces	kN	140		140	
	lb	31,500		31,500	
Stick Crowd Forces	kN	114		104	
	lb	25,650		23,400	

**Africa/Middle East Sourced  
320D2, 320D2 L**

Boom		Reach Boom	
Stick		Medium (R2.5B)	Long (R2.9B)
Bucket Tip Radius	mm	1554	1554
	ft	5'1"	5'1"
Bucket Curling Forces	kN	141	141
	lb	31,725	31,725
Stick Crowd Forces	kN	118	106
	lb	26,650	23,850

**Japan/China/Indonesia/Brazil Sourced  
320D2, 320D2 L**

Boom		Reach Boom			Mass Boom
Stick		Medium (R2.5B)	Long (R2.9B)	Extra Long (R3.9B)	Medium
Bucket Tip Radius	mm	1477	1477	1477	1555
	ft	4'10"	4'10"	4'10"	4'11"
Bucket Curling Forces	kN	131	131	131	166
	lb	29,450	29,450	29,450	37,318
Stick Crowd Forces	kN	117	105	86	125
	lb	26,303	23,605	19,334	28,100

**Brazil Sourced  
323D2 L**

Boom		Reach Boom		
Stick		R1.9CB	R2.5B1	R2.9B1
Bucket Tip Radius	mm	1610	1554	1554
	ft	5'3"	5'1"	5'1"
Bucket Curling Forces	kN	179	141	141
	lb	40,275	31,725	31,725
Stick Crowd Forces	kN	147	118	106
	lb	33,075	26,550	26,650
Boom		Mass Boom		
Stick		M2.4CB2		
Bucket Tip Radius	mm	1610		
	ft	5'3"		
Bucket Curling Forces	kN	188		
	lb	42,300		
Stick Crowd Forces	kN	130		
	lb	29,250		
Boom		VA Boom		
Stick		R1.9CB	R2.5B1	R2.9B1
Bucket Tip Radius	mm	1610	1554	1554
	ft	5'3"	5'1"	5'1"
Bucket Curling Forces	kN	179	141	141
	lb	40,275	31,725	31,725
Stick Crowd Forces	kN	147	118	106
	lb	33,075	26,550	26,650

7

**China Sourced  
323D2 L**

Boom		Reach Boom		
Stick		R2.5B1	R2.9B1	
		B1360HD-CXL		
Bucket Tip Radius	mm	1579		1579
	ft	5'2"		5'2"
Bucket Curling Forces	kN	140.4/124.9		140.4/124.9
	lb	31,563/28,079		31,563/28,079
Stick Crowd Forces	kN	117.9/113.9		106.4/103.2
	lb	26,505/25,606		23,920/23,200
Boom		Mass Boom		
Stick		M2.4CB2		
Bucket Tip Radius	mm	1683		
	ft	5'6"		
Bucket Curling Forces	kN	174.2/155.1		
	lb	39,162/34,868		
Stick Crowd Forces	kN	126.4/121.7		
	lb	28,416/27,359		



**Japan/U.S. Sourced  
326D2**

Boom		Reach Boom		
Stick		Medium	Long	Extra Long
Bucket Tip Radius	mm	1551	1551	1477
	ft	5'1"	5'1"	4'10"
Bucket Curling Forces	kN	186	186	172
	lb	41,814	41,814	38,667
Stick Crowd Forces	kN	148	127	113
	lb	33,272	28,551	25,471
Boom		Mass Boom		
Stick		Short	Medium	
Bucket Tip Radius	mm	1663	1663	
	ft	5'5"	5'5"	
Bucket Curling Forces	kN	189	239	
	lb	42,470	53,729	
Stick Crowd Forces	kN	151	147	
	lb	33,930	33,047	

**Japan/U.S. Sourced  
330D2**

Boom		Reach Boom			
Stick		Short	Medium	Long	Extra Long
Bucket Tip Radius	mm	1660	1487	1487	1488
	ft	5'5"	4'11"	4'11"	4'11"
Bucket Curling Forces	kN	201	200	201	160
	lb	45,187	44,962	45,187	36,000
Stick Crowd Forces	kN	152	133	120	124
	lb	34,171	29,900	26,977	27,900
Boom		Mass Boom			
Stick		Medium			
Bucket Tip Radius	mm	1660			
	ft	5'5"			
Bucket Curling Forces	kN	239			
	lb	53,729			
Stick Crowd Forces	kN	162			
	lb	36,419			

**Japan/U.S. Sourced  
336D**

Boom		Reach Boom			
Stick		Short	Medium	Long	Extra Long
Bucket Tip Radius	mm	1845	1660	1660	1660
	ft	<b>6'0"</b>	<b>5'5"</b>	<b>5'5"</b>	<b>5'5"</b>
Bucket Curling Forces	kN	238	238	190	191
	lb	<b>53,437</b>	<b>53,572</b>	<b>42,700</b>	<b>42,900</b>
Stick Crowd Forces	kN	170	152	161	140
	lb	<b>38,218</b>	<b>34,148</b>	<b>36,200</b>	<b>31,500</b>
Boom		Mass Boom			
Stick		M2.6E			
Bucket Tip Radius	mm	1845			
	ft	<b>6'1"</b>			
Bucket Curling Forces	kN	271			
	lb	<b>60,923</b>			
Stick Crowd Forces	kN	195			
	lb	<b>43,883</b>			

7

**Belgium Sourced  
336D L**

Boom		Reach Boom			
Stick		R2.1TB	R2.8DB	R3.2DB	R3.9DB
Bucket Tip Radius	mm	1897	1761	1761	1761
	ft	<b>6'3"</b>	<b>5'9"</b>	<b>5'9"</b>	<b>5'9"</b>
Bucket Curling Forces	kN	249	204	194	184
	lb	<b>56,025</b>	<b>45,900</b>	<b>43,650</b>	<b>41,400</b>
Stick Crowd Forces	kN	235	194	177	158
	lb	<b>52,875</b>	<b>43,650</b>	<b>39,825</b>	<b>35,550</b>
Boom		Mass Boom			
Stick		M2.15TB		M2.6TB	
Bucket Tip Radius	mm	1897		1897	
	ft	<b>6'3"</b>		<b>6'3"</b>	
Bucket Curling Forces	kN	249		233	
	lb	<b>56,025</b>		<b>52,425</b>	
Stick Crowd Forces	kN	235		208	
	lb	<b>52,875</b>		<b>46,800</b>	

- 349D2
- SAE

**349D2 per SAE**

Boom		Reach Boom		
Stick		Short	Medium	Long
Bucket Tip Radius	mm	1725	1725	1725
	ft	<b>5'8"</b>	<b>5'8"</b>	<b>5'8"</b>
Bucket Curling Forces	kN	258	258	258
	lb	<b>58,000</b>	<b>58,000</b>	<b>58,000</b>
Stick Crowd Forces	kN	220	201	186
	lb	<b>49,500</b>	<b>45,100</b>	<b>41,800</b>
Boom		Mass Boom		
Stick		Short	Medium	Long
Bucket Tip Radius	mm	2050	2050	2050
	ft	<b>6'9"</b>	<b>6'9"</b>	<b>6'9"</b>
Bucket Curling Forces	kN	203	203	203
	lb	<b>45,680</b>	<b>45,680</b>	<b>45,680</b>
Stick Crowd Forces	kN	228	203	203
	lb	<b>51,300</b>	<b>45,680</b>	<b>45,680</b>

**349D2**

Boom		Reach Boom		
Stick		Short	Medium	Long
Bucket Tip Radius	mm	1820	1820	1820
	ft	<b>6'0"</b>	<b>6'0"</b>	<b>6'0"</b>
Bucket Curling Forces	kN	234	234	234
	lb	<b>52,580</b>	<b>52,580</b>	<b>52,580</b>
Stick Crowd Forces	kN	216	197	183
	lb	<b>48,540</b>	<b>44,270</b>	<b>41,120</b>
Boom		Mass Boom		
Stick		Medium	Long	
Bucket Tip Radius	mm	2020	2020	
	ft	<b>6'8"</b>	<b>6'8"</b>	
Bucket Curling Forces	kN	263	263	
	lb	<b>59,100</b>	<b>59,100</b>	
Stick Crowd Forces	kN	230	204	
	lb	<b>51,690</b>	<b>45,840</b>	

### 349D2 L

Boom		Reach Boom		
Stick		Short	Medium	Long
Bucket Tip Radius	mm	1820	1820	1820
	ft	6'0"	6'0"	6'0"
Bucket Curling Forces	kN	234	234	234
	lb	52,580	52,580	52,580
Stick Crowd Forces	kN	216	197	183
	lb	48,540	44,270	41,120
Boom		Mass Boom		
Stick		Medium	Long	
Bucket Tip Radius	mm	2020	2020	
	ft	6'8"	6'8"	
Bucket Curling Forces	kN	263	263	
	lb	59,100	59,100	
Stick Crowd Forces	kN	230	204	
	lb	51,690	45,840	

7

### 349F L per ISO

Boom		Reach Boom		Long Reach Boom	Mass Boom	
Stick		R3.35TB	R3.9TB	R4.3TB	M2.5UB	M3.0UB
Bucket Tip Radius	mm	1865	1865	1866	2057	2057
	ft	6'1"	6'1"	6'1"	6'9"	6'9"
Bucket Curling Forces	kN	268	268	267	296	296
	lb	60,250	60,250	60,020	66,540	66,540
Stick Crowd Forces	kN	201	184	170	241	212
	lb	45,190	41,360	38,220	54,180	47,660

**Belgium Sourced  
365C L per ISO**

Boom		7.80 m (25'7") Reach Boom			
Stick		R2.84VB	R3.6VB	R4.15VB	R4.67VB
Bucket Tip Radius	mm	1903	1862	1862	1862
	ft	6'2"	5'9"	5'9"	5'9"
Bucket Curling Forces	kN	295	284	271	264
	lb	66,380	63,900	60,980	59,400
Stick Crowd Forces	kN	287	265	243	229
	lb	64,580	59,630	54,680	51,530
Boom		6.6 m (21'8") Mass Boom		7 m (23'0") Mass Boom	
Stick		M2.57WB	M3.0WB	M2.57WB	M3.0WB
Bucket Radius at Cutting Edge	mm	2015	2015	2015	2015
	ft	6'6"	6'6"	6'6"	6'6"
Bucket Force	kN	332	321	332	321
	lb	74,700	72,230	74,700	72,230
Stick Force	kN	309	289	309	288
	lb	69,530	65,030	69,530	64,800

**Belgium Sourced  
385C/385C L per ISO**

Boom		Reach Boom 10 m (32'10")			
Stick		R4.4HB		R5.5HB	
Bucket Radius at Cutting Edge	mm	1959		1959	
	ft	6'5"		6'5"	
Bucket Digging Force	kN	335		316	
	lb	75,380		71,100	
Stick Digging Force	kN	293		256	
	lb	65,930		57,600	
Boom		General Purpose Boom 8.4 m (27'7")			
Stick		G3.4JB	G4.4HB	G5.5HB	
Bucket Radius at Cutting Edge	mm	2175	1959	1959	
	ft	7'2"	6'5"	6'5"	
Bucket Digging Force	kN	384	334	315	
	lb	86,400	75,150	70,880	
Stick Digging Force	kN	342	293	257	
	lb	76,950	65,930	57,830	
Boom		Mass Boom 7.25 m (23'9")			
Stick		M2.92JB	M3.4JB		
Bucket Radius at Cutting Edge	mm	2233	2233		
	ft	7'4"	7'4"		
Bucket Digging Force	kN	394	385		
	lb	88,650	86,630		
Stick Digging Force	kN	362	344		
	lb	81,450	77,400		

Caterpillar offers a very comprehensive list of high strength steel buckets. High strength steel allows thinner components which helps keep the weight down, maintains durability and improves loadability. The wrong bucket can reduce production 30-40% or more. Caterpillar's in-depth knowledge of machine design, bucket design

and application experience allows offering **machine matched** packages that optimize performance.

Additional buckets may be available and the listed buckets may not be available in all sales areas. Contact your Cat dealer for your specific bucket needs.

Model	Bucket Type	Teeth	Bucket Bite Width		Rated Capacity <sup>1</sup> (Heaped)		Weight <sup>2</sup> Calculated		Tip Radius	
			mm	in	m <sup>3</sup>	ft <sup>3</sup>	lb	kg	mm	in
300.9D	Digging	3	250	9.8	0.014	0.494	33.0	14.8	432.0	17.0
		3	370	14.6	0.018	0.636	38.0	17.2	432.0	17.0
	Ditch Cleaning	0	700	27.6	0.027	0.950	54.0	24.5	326.0	12.8
301.4C, 301.7D, 301.7D CR	Digging	3	230	9.0	0.018	0.620	64.6	29.4	500.0	20.0
		3	300	12.0	0.022	0.780	68.5	31.1	500.0	20.0
		3	400	16.0	0.033	1.160	77.8	35.4	500.0	20.0
		3	457	18.0	0.040	1.400	83.3	37.9	500.0	20.0
		4	500	20.0	0.045	1.590	90.1	40.9	500.0	20.0
	Ditch Cleaning	4	600	24.0	0.056	1.970	100.0	45.4	500.0	20.0
		0	800	32.0	0.042	1.500	89.1	40.5	355.0	14.0
	Tilting Ditch Cleaning	0	1000	40.0	0.057	2.000	93.5	42.5	355.0	14.0
		0	1000	40.0	0.055	1.900	167.0	76.0	491.0	19.3
Mud	0	1000	40.0	0.088	3.110	123.0	56.0	446.0	17.6	
302.2D, 302.4D, 302.7D CR	Digging	3	260	10.0	0.027	0.970	103.3	46.9	590.5	23.2
		3	300	12.0	0.034	1.210	100.6	45.6	590.5	23.2
		3	400	16.0	0.045	1.590	111.0	50.4	590.5	23.2
		3	457	18.0	0.053	1.890	118.7	53.9	590.5	23.2
		4	500	20.0	0.060	2.110	129.0	58.5	590.5	23.2
		4	600	24.0	0.076	2.690	142.7	64.7	590.5	23.2
		4	700	28.0	0.092	3.250	156.3	70.9	590.5	23.2
	Ditch Cleaning	0	800	32.0	0.080	2.800	179.0	81.4	478.0	18.8
		0	1000	40.0	0.102	3.600	172.0	78.2	478.0	18.8
		0	1200	47.0	0.116	4.100	193.0	87.7	478.0	18.8
	Tilting Ditch Cleaning	0	1100	43.0	0.110	3.880	293.0	133.0	650.0	25.6
	Mud	0	1000	40.0	0.173	6.110	172.0	78.0	595.0	23.4
	303E CR, 303.5E CR, 303.5E2 CR, 304E CR, 304E2 CR, 304.5E2 XTC	Ditch Cleaning	0	1000	40.0	0.130	4.800	240.0	109.0	545.0
0			1200	47.0	0.160	5.900	235.0	107.0	545.0	21.5
0			1400	55.0	0.197	6.960	259.0	118.0	545.0	21.5
Heavy Duty		3	305	12.0	0.050	1.700	139.0	63.0	737.0	29.0
		3	406	16.0	0.070	2.500	158.0	72.0	737.0	29.0
		4	457	18.0	0.080	2.900	176.0	80.0	737.0	29.0
		4	508	20.0	0.090	3.300	193.0	88.0	737.0	29.0
		4	610	24.0	0.120	4.200	217.0	99.0	737.0	29.0
		5	762	30.0	0.160	5.600	253.0	115.0	737.0	29.0
Tilting Ditch Cleaning		5	914	36.0	0.190	7.000	300.0	136.0	737.0	29.0
		0	1200	47.0	0.159	5.600	357.0	162.0	725.0	28.5
Mud		0	1200	47.0	0.232	8.190	331.0	150.0	628.0	24.7

<sup>1</sup> Capacities shown as per ISO 7451:1997.

<sup>2</sup> Weight shown includes standard ground engaging tools.

Model	Bucket Type	Teeth	Bucket Bite Width		Rated Capacity <sup>1</sup> (Heaped)		Weight <sup>2</sup> Calculated		Tip Radius	
			mm	in	m <sup>3</sup>	ft <sup>3</sup>	lb	kg	mm	in
305E CR, 305E2 CR, 305.5E CR, 305.5E2 CR	Ditch Cleaning	0	1000	<b>40.0</b>	0.170	<b>6.000</b>	258.0	<b>117.0</b>	584.0	<b>23.0</b>
		0	1300	<b>51.0</b>	0.220	<b>7.800</b>	260.0	<b>118.0</b>	584.0	<b>23.0</b>
		0	1600	<b>63.0</b>	0.280	<b>9.900</b>	306.0	<b>139.0</b>	584.0	<b>23.0</b>
	Heavy Duty	3	305	<b>12.0</b>	0.059	<b>2.100</b>	151.0	<b>69.0</b>	785.0	<b>31.0</b>
		3	406	<b>16.0</b>	0.076	<b>2.700</b>	170.0	<b>77.0</b>	785.0	<b>31.0</b>
		4	457	<b>18.0</b>	0.088	<b>3.100</b>	189.0	<b>86.0</b>	785.0	<b>31.0</b>
		4	508	<b>20.0</b>	0.102	<b>3.600</b>	207.0	<b>94.0</b>	785.0	<b>31.0</b>
		4	610	<b>24.0</b>	0.130	<b>4.600</b>	234.0	<b>106.0</b>	785.0	<b>31.0</b>
		5	762	<b>30.0</b>	0.173	<b>6.100</b>	274.0	<b>125.0</b>	785.0	<b>31.0</b>
	Heavy Duty Capacity	5	914	<b>36.0</b>	0.221	<b>7.800</b>	320.0	<b>146.0</b>	785.0	<b>31.0</b>
		3	305	<b>12.0</b>	0.082	<b>2.900</b>	179.0	<b>81.0</b>	852.0	<b>33.5</b>
		3	406	<b>16.0</b>	0.105	<b>3.700</b>	200.0	<b>91.0</b>	852.0	<b>33.5</b>
		4	457	<b>18.0</b>	0.125	<b>4.400</b>	220.0	<b>100.0</b>	852.0	<b>33.5</b>
		4	508	<b>20.0</b>	0.144	<b>5.100</b>	241.0	<b>110.0</b>	852.0	<b>33.5</b>
	Tilting Ditch Cleaning	4	610	<b>24.0</b>	0.181	<b>6.400</b>	271.0	<b>123.0</b>	852.0	<b>33.5</b>
		5	762	<b>30.0</b>	0.241	<b>8.500</b>	316.0	<b>144.0</b>	852.0	<b>33.5</b>
	Mud	5	914	<b>36.0</b>	0.300	<b>10.600</b>	366.0	<b>166.0</b>	852.0	<b>33.5</b>
		0	1600	<b>63.0</b>	0.280	<b>9.900</b>	551.0	<b>251.0</b>	795.0	<b>31.3</b>
	307E2, 308E2 CR SB 308E2 VAB	Ditch Cleaning	0	1200	<b>47.0</b>	0.260	<b>9.180</b>	357.0	<b>162.0</b>	693.0
0			1500	<b>59.0</b>	0.330	<b>11.700</b>	428.0	<b>194.0</b>	693.0	<b>27.2</b>
0			1219	<b>48.0</b>	0.329	<b>11.600</b>	476.0	<b>216.0</b>	791.0	<b>31.1</b>
0			1372	<b>54.0</b>	0.375	<b>13.200</b>	516.0	<b>235.0</b>	791.0	<b>31.1</b>
0			1524	<b>60.0</b>	0.421	<b>14.900</b>	556.0	<b>253.0</b>	791.0	<b>31.1</b>
Heavy Duty		0	1500	<b>59.0</b>	0.240	<b>8.500</b>	319.0	<b>145.0</b>	658.0	<b>26.0</b>
		0	1800	<b>71.0</b>	0.300	<b>10.600</b>	365.0	<b>166.0</b>	658.0	<b>26.0</b>
		3	330	<b>13.0</b>	0.100	<b>3.500</b>	275.0	<b>125.0</b>	1015.0	<b>40.0</b>
		4	457	<b>18.0</b>	0.150	<b>5.300</b>	333.0	<b>151.0</b>	1015.0	<b>40.0</b>
		4	610	<b>24.0</b>	0.230	<b>8.100</b>	392.0	<b>178.0</b>	1015.0	<b>40.0</b>
Heavy Duty Rock		5	762	<b>30.0</b>	0.310	<b>10.900</b>	455.0	<b>207.0</b>	1015.0	<b>40.0</b>
		5	914	<b>36.0</b>	0.390	<b>13.700</b>	507.0	<b>230.0</b>	1015.0	<b>40.0</b>
		4	610	<b>24.0</b>	0.230	<b>8.100</b>	427.0	<b>194.0</b>	1015.0	<b>40.0</b>
Mud		5	762	<b>30.0</b>	0.310	<b>10.900</b>	490.0	<b>223.0</b>	1015.0	<b>40.0</b>
		0	1200	<b>47.0</b>	0.410	<b>14.500</b>	589.0	<b>267.0</b>	894.0	<b>35.2</b>
Mud		0	1500	<b>59.0</b>	0.520	<b>18.400</b>	689.0	<b>313.0</b>	894.0	<b>35.2</b>

<sup>1</sup> Capacities shown as per ISO 7451:1997.

<sup>2</sup> Weight shown includes standard ground engaging tools.

## **NEW NOMENCLATURE FOR HYDRAULIC EXCAVATOR BUCKETS**

Caterpillar will soon be moving to a new global nomenclature for buckets on small, medium and large HEX machines and associated linkages. The end result will be a manageable, consistent bucket offering in all regions regardless of where the machine or bucket may be built and shipped. The new bucket designs and nomenclature will be introduced over the next several years, as D and E Series HEX machines are introduced.

### **Why the change?**

#### **Consistent product line**

Buckets currently sold into different regions of the world have been designed and manufactured independent of each other resulting in different bucket styles and nomenclature. As Caterpillar becomes more global, we recognize this can lead to confusion in the marketplace as machines and buckets are sourced from different areas.

### **Improved bucket selection**

Caterpillar continues to recognize the need for a range of buckets for various applications and with varying durability requirements — from site development to granite quarries. The new, global nomenclature is simplified, consistent, and based on the durability of the bucket. These considerations allow a clear and consistent bucket positioning to help facilitate appropriate bucket selection and recommendation — and put Caterpillar in a better position to support machines on a global scale.

Dealers and customers in North America will see changes in bucket nomenclature and improvement in bucket designs.

### **What dealers will see with the change**

Today, North American HEX buckets are grouped into three main categories: General Purpose (GP), Heavy Duty (HD), and Heavy Duty Rock (HDR). New nomenclature brings in four primary categories, each represent durability. They are: General Duty (GD), Heavy Duty (HD), Severe Duty (SD), and Extreme Duty (XD). Within the Extreme Duty class a new bucket specific for use in granite will be available for the large excavators.



The diagram below illustrates how today's nomenclature aligns with the new, followed by a brief description of each category.

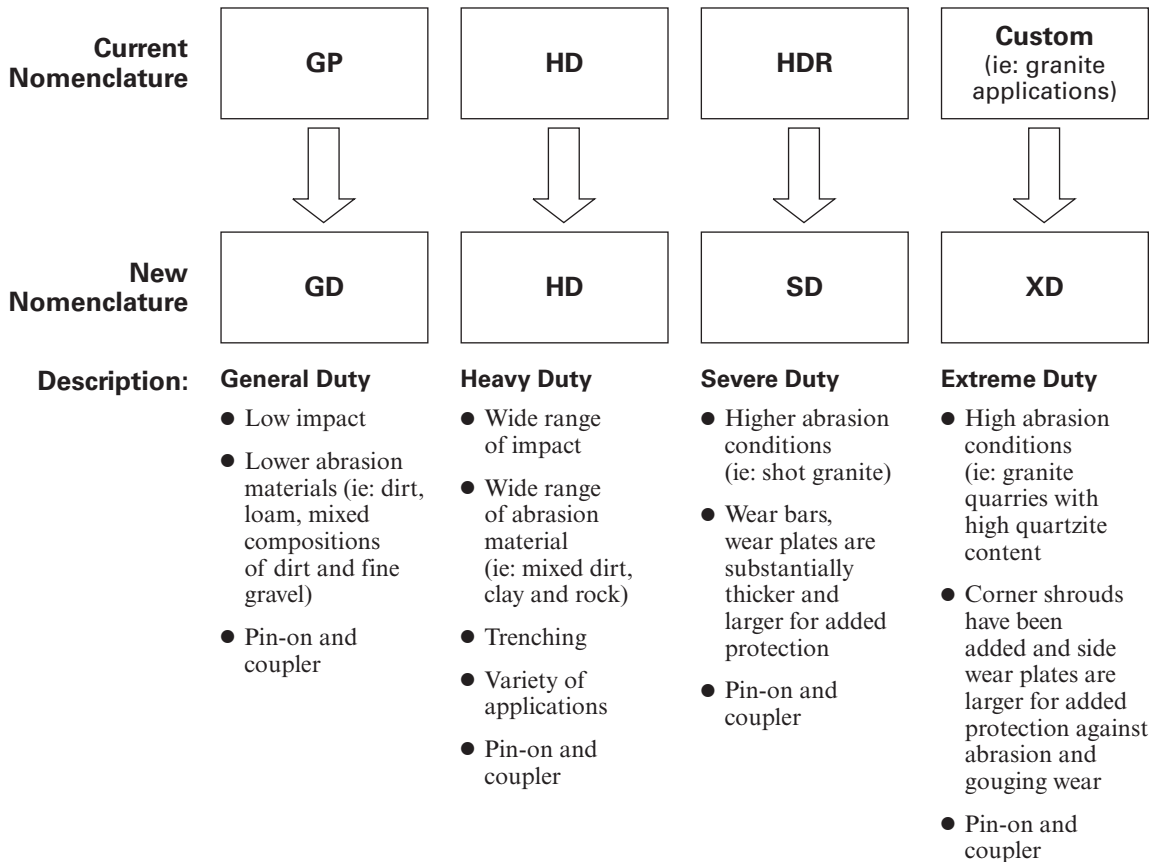

## BUCKET TYPES

### General Duty

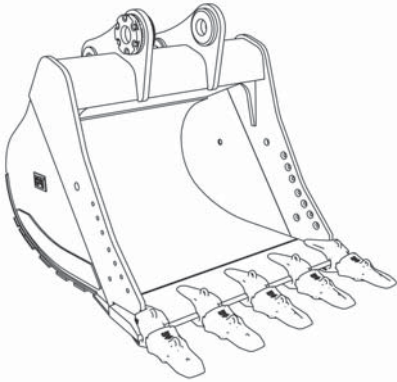

For digging in low impact, lower abrasion materials such as dirt, loam, and mixed compositions of dirt and fine gravel. Example: Digging conditions in which General Duty tip life exceeds 800 hours.

Typically larger General Duty buckets are the most popular sizes, and are used by site developers to mass excavate in low abrasion applications.

- Lighter structures decrease load time and increase the weight that can be lifted.
- Standard size adapters and tips.
- Sidebars are pre-drilled for optional sidecutters and sidebar protectors.

### Heavy Duty

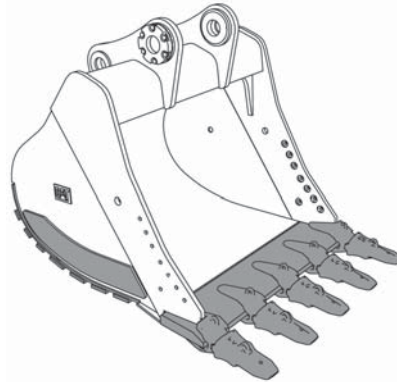

The most popular excavator bucket style. A good “center line” choice, or starting point, when application conditions are not well known.

For a wide range of impact and abrasion conditions including mixed dirt, clay and rock. Example: Digging conditions where Penetration Plus tip life ranges from 400 to 800 hours.

Heavy Duty Buckets are recommended for trenching in utilities work, and for the general contractor working in a variety of different situations.

- Thicker bottom and side wear plates than General Duty buckets for more durability.
- Adapters and tips are up-sized for enhanced performance and durability.
- Sidebars are pre-drilled for optional sidecutters and sidebar protectors.

### Severe Duty

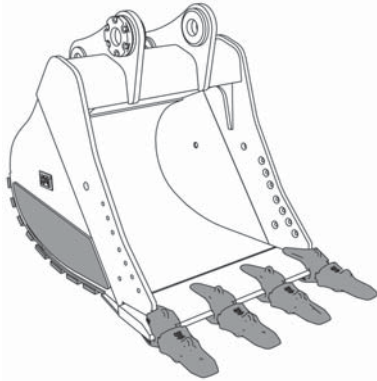

For higher abrasion conditions such as well shot granite and caliche. Example: Digging conditions where tip life ranges from 200 to 400 hours with Penetration Plus tips.

- Bottom wear plates are about 50% thicker than Heavy Duty buckets.
- Side wear plates are about 40% larger than Heavy Duty buckets for added protection against abrasive and gouging wear.
- Heavy Duty and Severe Duty buckets use same size adapters.
- Adapters are sized to accommodate higher abrasion conditions.
- Tips are up-sized (over the General Duty bucket) for enhanced performance and durability.
- Sidebars are pre-drilled for optional sidecutters and sidebar protectors.

### Extreme Duty

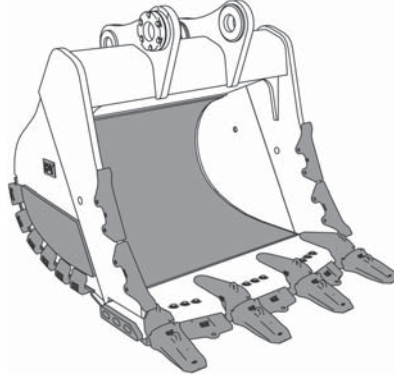

For very high abrasion conditions including high quartzite granite. Example: Digging conditions where tip life is less than or equal to 200 hours with Extra Duty tips.

- Corner (or heel) shrouds, Base Edge End Protectors (BEEPs), base edge segments, liners, and Mechanically Attached Wear Plates (MAWPs) protect the bucket from wear.
- Side wear plates are larger.
- Sidebar protection has been added for protection against abrasion and gouging wear.
- Adapters are sized to accommodate higher abrasion conditions.
- Tips are up-sized (over the General Duty bucket) for enhanced performance and durability.

### Special Purpose Buckets

Caterpillar offers a range of special purpose buckets, variants of the durabilities listed above, to meet particular application needs.

#### Ditch Cleaning



These buckets are designed for cleaning ditches, sloping, grading and other finish work. Their shallow depth and compact size make working in confined areas easier. Drainage holes allow liquid to empty so material dumps more easily.

#### Ditch Cleaning Tilt

Tilt Buckets feature a full 45° of tilt in each direction, powered by two double-acting cylinders. Ditch Cleaning and Tilt Buckets are available for 311-336 excavators.

### Center-Lock™ Pin Grabber Performance

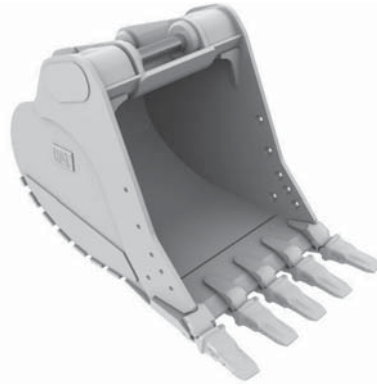

This bucket is designed with a patented recessed pin to provide maximum digging performance while keeping the versatility and convenience of a coupler. Tip radius is reduced and allows up to 10% improvement in breakout force when compared to a conventional pin-on Bucket and Coupler combination.

Center-Lock Performance Buckets are available for 315-345 excavators, in General Duty, Heavy Duty and Severe Duty durabilities.

### Power



Power Buckets are for use in abrasive applications where breakout force and cycle times are critical — and for use in materials such as tightly compacted mixed dirt and rock. (Not recommended for clay.) Breakout force is maximized due to decreased tip radius and increased pin spread. Machine cycle times in most material is improved over a standard bucket in a similar application. Heavy Duty Power Buckets are available for 320-336 excavators.

### Wide Tip



Wide Tip Buckets are intended to perform best in low-impact materials such as dirt and loam where leaving a smoother floor and minimal spillage is necessary. The bucket is engineered to be used exclusively with Cat Wide Tips. Corner adapters face straight forward to create a smooth edge. General Purpose Wide Tip Buckets are available in widths from 24" to 78" for 311-345 excavators.

## High Capacity



High Capacity Buckets are designed and built for use in high production truck loading applications. With proper application and set up, these buckets will move more material in a minimal amount of passes — maximizing production. High Capacity Buckets are available for 349-390 excavators, in General Duty durability.

## BUCKET SALES SUPPORT

The latest sales literature for HEX Buckets worldwide can be found in Work Tool Central at <https://dealer.cat.com/products/wtc>.

- HEX Bucket Specalog (NACD) — GEHQ0201
- 374D Buckets Product Bulletin — GEJQ0231

**BUCKET PAYLOAD**

An excavator's bucket payload (actual amount of material in the bucket on each digging cycle) is dependent on bucket size, shape, curl force, and certain soil characteristics, i.e., the fill factor for that soil. Fill factors for several types of material are listed below.

$$\text{Average Bucket Payload} = (\text{Heaped Bucket Capacity}) \times (\text{Bucket Fill Factor})$$

Material	Fill Factor Range (Percent of heaped bucket capacity)
Moist Loam or Sandy Clay	A — 100-110%
Sand and Gravel	B — 95-110%
Hard, Tough Clay	C — 80-90%
Rock — Well Blasted	60-75%
Rock — Poorly Blasted	40-50%

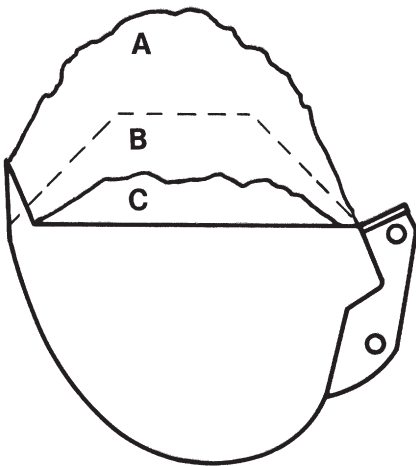

**Working Weights — Bucket & Payload**

*The following tables give maximum “bucket plus payload” weights to assist in selecting the correct bucket for a specific application. These weights are based on actual job conditions. In better than average conditions the excavator may be able to achieve rated lift capacities listed in this section.*

**NOTE:** Bucket sizes are suitable for a maximum material density of 1800 kg/m<sup>3</sup> (3035 lb/yd<sup>3</sup>). Payloads shown are calculated at 1500 kg/m<sup>3</sup> (2530 lb/yd<sup>3</sup>).

Model	Boom	Stick Length		Working Weights† Buckets & Payload	
		m	ft	kg	lb
300.9D	Swing	0.89	2'11"	—	—
301.4C/ 301.7D/ 301.7D CR	Swing	0.89	2'11"	234	516
		1.09	3'6"	210	463
302.2D/ 302.4D/ 302.7D CR	Swing	1.05	3'5"	—	—
		1.40	4'4"	—	—
303E CR	Swing	To Be Determined			
303.5E CR	Swing	1.26	4'2"	274	604
		1.56	5'1"	225	496
304E CR/ 304.5E2 XTC	Swing	1.32	4'4"	274	604
		1.62	5'4"	225	496
305E2 CR	Swing	1.38	4'6"	513	1130
		1.78	5'10"	464	1020
305.5E2 CR	Swing	1.43	4'8"	513	1130
307E2	Fixed	1.83	6'0"	464	1020
		1.67	5'6"	1153	2430
308E2 CR SB/ 308E2 VAB	Swing	1.67	5'6"	1153	2430
		2.21	7'3"	899	1980
311D LRR	Reach	2.25	7'5"	1537	3390
		2.60	8'6"	1295	2850
		2.80	9'2"	1295	2850
312D	Reach	2.10	6'11"	1720	3790
		2.50	8'2"	1592	3510
		2.80	9'2"	1402	3090
		3.00	9'10"	1402	3090
312D L	Reach	2.10	6'11"	1764	3890
		2.50	8'2"	1633	3600
		2.80	9'2"	1439	3170
		3.00	9'10"	1439	3170
313C SR	Parallel Offset	2.13	7'0"	2060	4540
		2.13	7'0"	1537	3390
313C CR	Reach	2.50	8'2"	1240	2730
		3.00	9'10"	1075	2370

†Working weights may vary depending on machine configuration and geographic location. Contact your Cat dealer for specific information.

Model	Boom	Stick Length		Working Weights† Buckets & Payload			
		m	ft	kg	lb		
314D CR		2.50	8'2"	1538	3390		
		2.80	9'2"	1351	2980		
		3.00	9'10"	1351	2980		
314D LCR	Reach	2.50	8'2"	1560	3440		
		2.80	9'2"	1372	3020		
		3.00	9'10"	1372	3020		
315D L	Reach	1.85	6'1"	2141	4720		
		2.25	7'5"	2018	4450		
		2.60	8'6"	1862	4110		
		2.90	9'6"	1719	3790		
		3.10	10'2"	1719	3790		
319D L		1.80	5'11"	3158	6963		
		2.25	7'5"	2883	6357		
		2.70	8'10"	2649	5841		
		3.20	10'6"	2309	5091		
319D LN		1.80	5'11"	2759	6084		
		2.25	7'5"	2522	5561		
		2.70	8'10"	2317	5109		
		3.20	10'6"	2010	4432		
320D2	Reach	2.50	8'2"	2560	5632		
		2.90	9'7"	2460	5412		
320D2 L	Reach	2.50	8'2"	2900	6380		
		2.90	9'7"	2750	6050		
321D LCR	Reach	2.90	9'6"	2830	6250		
320F/ 323F	Reach	2.50	8'2"	3344	7374		
		2.90	9'6"	3096	6827		
	VA	2.50	8'2"	2910	6417		
		2.90	9'6"	2695	5942		
323F LN	Reach	2.50	8'2"	2815	6207		
		2.90	9'6"	2745	6053		
		VA	2.50	8'2"	2406	5305	
		2.90	9'6"	2218	4891		
		323D2 L	Reach	2.9 HD	9'6"	23 100/ 25 510	50,926/ 56,240
				2.5 HD	8'2"	23 070/ 25 490	50,860/ 56,195
Mass	M2.4	7'9"	23 170/ 25 600	51,081/ 56,438			

†Working weights may vary depending on machine configuration and geographic location. Contact your Cat dealer for specific information.



Model	Boom	Stick Length		Working Weights† Buckets & Payload	
		m	ft	kg	lb
<b>336D Belgium</b>	Reach	2.15	<b>7'1"</b>	4500	<b>9920</b>
		2.80	<b>9'2"</b>	4000	<b>8820</b>
		3.30	<b>10'10"</b>	3690	<b>8140</b>
		3.90	<b>12'10"</b>	3250	<b>7170</b>
	Mass	2.15	<b>7'1"</b>	5030	<b>11,090</b>
		2.55	<b>8'4"</b>	4440	<b>9790</b>
<b>336D L Belgium</b>	Reach	2.15	<b>7'1"</b>	4700	<b>10,360</b>
		2.80	<b>9'2"</b>	4160	<b>9170</b>
		3.30	<b>10'10"</b>	3830	<b>8440</b>
		3.90	<b>12'10"</b>	3240	<b>7540</b>
	Mass	2.15	<b>7'1"</b>	5210	<b>11,490</b>
		2.55	<b>8'4"</b>	4640	<b>10,230</b>
<b>336D L</b>	Reach	2.15	<b>7'1"</b>	4700	<b>10,360</b>
		2.80	<b>9'2"</b>	4160	<b>9170</b>
		3.30	<b>10'10"</b>	3830	<b>8440</b>
		3.90	<b>12'10"</b>	3240	<b>7540</b>
	Mass	2.15	<b>7'1"</b>	5210	<b>11,490</b>
		2.55	<b>8'4"</b>	4640	<b>10,230</b>
<b>336D LN Belgium</b>	Reach	2.15	<b>7'1"</b>	4150	<b>9150</b>
		2.80	<b>9'2"</b>	3700	<b>8160</b>
		3.30	<b>10'10"</b>	3410	<b>7520</b>
		3.90	<b>12'10"</b>	3000	<b>6610</b>
	Mass	2.15	<b>7'1"</b>	4660	<b>10,270</b>
		2.55	<b>8'4"</b>	4100	<b>9040</b>
		3.50	<b>11'6"</b>	3530	<b>7780</b>
<b>345B Series II - ES</b>	Reach	2.90	<b>9'6"</b>	8417	<b>18,560</b>
		3.40	<b>11'2"</b>	7886	<b>17,390</b>
	Mass	2.50	<b>8'2"</b>	9636	<b>21,240</b>
		3.00	<b>9'10"</b>	8986	<b>19,810</b>
<b>345D L (FIX)</b>	Long Reach	3.90	<b>12'10"</b>	4250	<b>9370</b>
		4.30	<b>14'1"</b>	3940	<b>8690</b>
	Reach	2.90	<b>9'6"</b>	5550	<b>12,240</b>
		3.35	<b>11'0"</b>	5180	<b>11,420</b>
		3.90	<b>12'10"</b>	4850	<b>10,690</b>
Mass	2.50	<b>8'2"</b>	6260	<b>13,800</b>	
	3.00	<b>9'10"</b>	5790	<b>12,760</b>	
<b>345D L (VG)</b>	Long Reach	3.90	<b>12'10"</b>	4540	<b>10,010</b>
		4.30	<b>14'1"</b>	4880	<b>10,760</b>
	Reach	2.90	<b>9'6"</b>	6830	<b>15,060</b>
		3.35	<b>11'0"</b>	6930	<b>15,280</b>
		3.90	<b>12'10"</b>	6000	<b>13,230</b>
Mass	2.50	<b>8'2"</b>	7550	<b>16,640</b>	
	3.00	<b>9'10"</b>	6790	<b>14,970</b>	

†Working weights may vary depending on machine configuration and geographic location. Contact your Cat dealer for specific information.

Model	Boom	Stick Length		Working Weights† Buckets & Payload		
		m	ft	kg	lb	
<b>365C L Belgium</b>	Reach	2.84	<b>9'3"</b>	9965	<b>21,970</b>	
		3.60	<b>11'8"</b>	9026	<b>19,900</b>	
		4.15	<b>13'6"</b>	8262	<b>18,220</b>	
		4.67	<b>15'3"</b>	7544	<b>16,640</b>	
	Mass	6.6 m ( <b>21'9"</b> )	2.57	<b>8'4"</b>	12 955	<b>28,570</b>
			3.00	<b>9'8"</b>	11 956	<b>26,360</b>
<b>385C Belgium</b>	Mass	7 m ( <b>23'0"</b> )	2.57	<b>8'4"</b>	11 798	<b>26,020</b>
			3.00	<b>9'8"</b>	10 907	<b>24,050</b>
	Reach	4.40	<b>14'4"</b>	6851	<b>15,110</b>	
		5.50	<b>18'0"</b>	5917	<b>13,050</b>	
	General Purpose	3.40	<b>11'1"</b>	10 359	<b>22,840</b>	
3.70		<b>12'1"</b>	10 018	<b>22,090</b>		
4.40		<b>14'4"</b>	9725	<b>21,440</b>		
Mass	5.50	<b>18'0"</b>	8412	<b>18,550</b>		
<b>385C L Belgium</b>	Reach	2.92	<b>9'6"</b>	14 209	<b>31,330</b>	
		3.40	<b>11'2"</b>	13 257	<b>29,230</b>	
	General Purpose	4.40	<b>14'4"</b>	7169	<b>15,810</b>	
		5.50	<b>18'0"</b>	6209	<b>13,690</b>	
	Mass	3.40	<b>11'2"</b>	10 755	<b>23,720</b>	
3.70		<b>12'1"</b>	10 411	<b>22,960</b>		
4.40		<b>14'4"</b>	10 089	<b>22,250</b>		
Mass	5.50	<b>18'0"</b>	8742	<b>19,280</b>		
		2.92	<b>9'6"</b>	14 309	<b>31,550</b>	
		3.40	<b>11'2"</b>	13 380	<b>29,500</b>	

†Working weights may vary depending on machine configuration and geographic location. Contact your Cat dealer for specific information.

## Long Reach

- Introduction
- Range Dimensions
- Bucket Information

### INTRODUCTION

Long reach excavators are designed purposely for light duty digging that requires reach capability well above that of normal digging machines. To be able to have high enough digging forces together with an acceptable size bucket, the long reach excavators have a smaller digging envelope than the ditch cleaning machines. Long reach excavators are ideally suited for deep digging in gravel or sand pits then feeding directly into a hopper.

Caterpillar's long reach hydraulic excavators use purpose-built booms and sticks designed by Caterpillar for maximum performance and durability in light duty applications.

Long Reach Excavation Fronts include: boom, stick, linkage cylinders (boom, stick, and bucket), hydraulic lines, additional counterweight for stability over the side and heavy duty wide undercarriage. Dimensions include light excavation bucket.

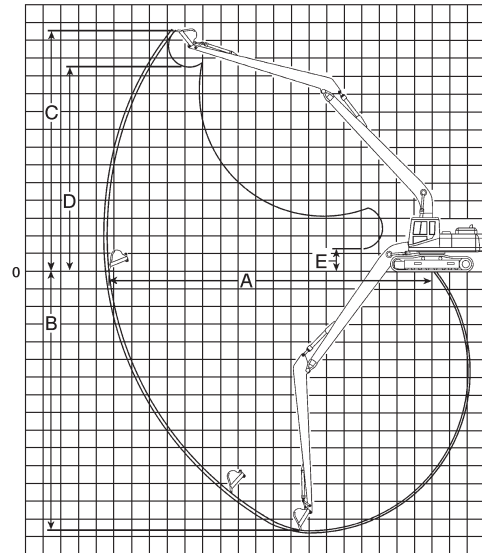

### Long Reach, Range Dimensions

#### 320D2 L

	m	ft
<b>A</b> Maximum Reach at Ground Level	15.72	51'7"
<b>B</b> Maximum Digging Depth	11.87	38'11"
<b>C</b> Maximum Cutting Height	13.30	43'8"
<b>D</b> Maximum Dumping Height	11.02	36'2"
<b>E</b> Minimum Loading Height	1.97	6'6"

### Long Reach, Bucket Information

Model	Bucket Type	Bucket Width		SAE Heaped Cap.		Bucket Weight		No. of Teeth	Bucket Curl Force		Stick Crowd Force	
		mm	ft	L	yd <sup>3</sup>	kg	lb		kN	lb	kN	lb
320D2 L (ISO)	Excavation	810	2'8"	450	0.6	340	750	5	61	13,691	49	10,948
320D2 L (SAE)	Excavation	810	2'8"	450	0.6	340	750	5	54	12,185	48	10,813

## Hydraulic Excavators

### Long Reach

- Shipping Dimensions
- Major Component Weights

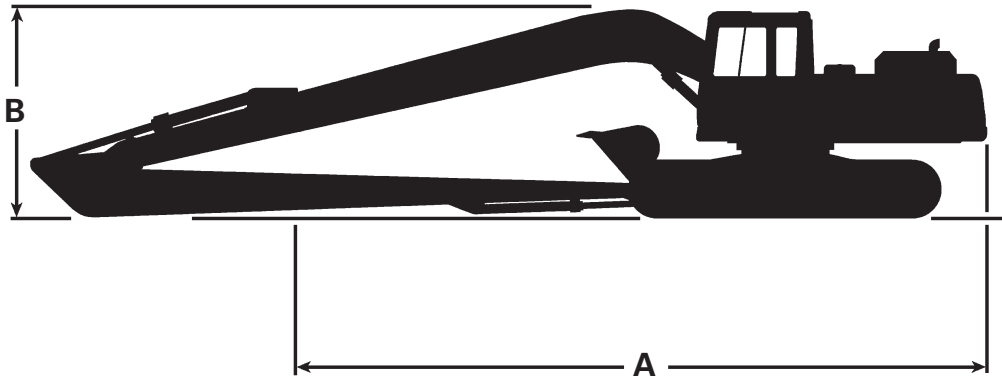

### Long Reach, Shipping Dimensions

#### 320D2 L

	m	ft
<b>A</b> Overall Length (Front Folded)	12.68	41'7"
<b>B</b> Overall Height	3.05	10'0"
<b>C</b> Overall Width	3.17	10'5"

### Long Reach, Component Weights

#### 320D2 L

	kg	lb
Total Component Weight – Includes additional over standard	4810	10,600
Long Reach Boom	2350	5180
Long Reach Stick	1020	2250

- Introduction
- Range Dimensions
- Bucket Information

## INTRODUCTION

Long Reach Excavation machines are designed specifically for jobs requiring longer reach than standard excavators, combined with digging capabilities.

The boom and the stick are purposely designed to perform digging operations with an acceptable bucket size.

The performances of the machine are attained through the use of bigger boom cylinders, heavy-duty wide undercarriage and significant additional counterweight. A heavy-duty upper-frame is also used in order to guarantee durability and resistance to the extra stresses generated by that demanding application.

Long Reach Excavation machines are ideally suited for deep or long distance digging in sand or gravel pits, slope forming, cleaning of settling banks, river conservation and other work formerly reserved for draglines.

These excavators can of course feed directly into a hopper or load a truck that would stand by their side.

The boom and the stick are designed following Caterpillar's standards, in order to provide the maximum performance and durability in digging applications.

Long Reach Excavation Fronts include: boom, stick, linkage (boom, stick, and bucket cylinders), hydraulic lines and additional counterweight.

Dimensions include the bucket.

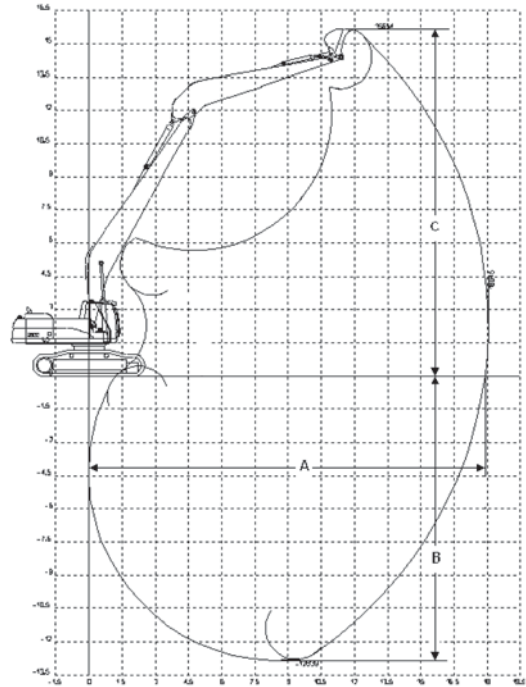

Long Reach Excavation, Range Dimensions	330D HDHW LRE Long	385C LRE Long
Undercarriage	Heavy Duty High Wide (HDHW)	Long Variable Gauge (LVG)
Boom Length	10 660 mm	12 500 mm
Stick Length	7100 mm	9500 mm
<b>A</b> Maximum Reach	18 045 mm	21 310 mm
<b>B</b> Maximum Digging Depth	12 890 mm	15 825 mm
<b>C</b> Maximum Cutting Height	15 580 mm	16 015 mm

## Hydraulic Excavators

### Long Reach Excavation

- Shipping Dimensions
- Major Component Dimensions and Weights

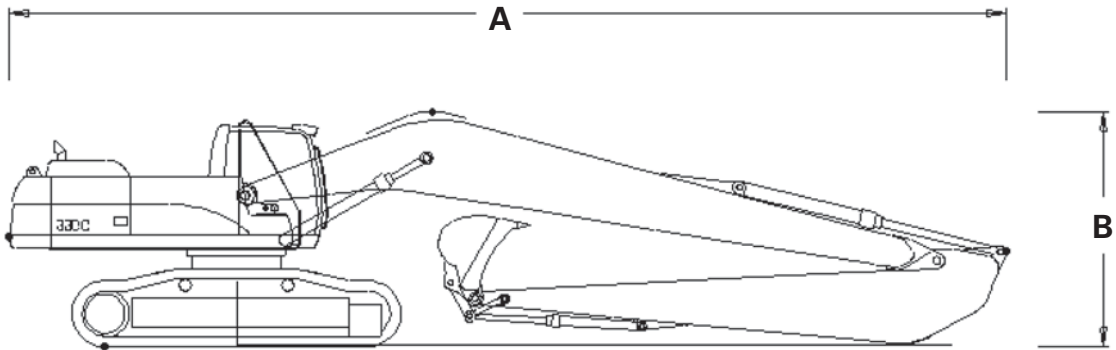

### Long Reach Excavation, Shipping Dimensions and Weight

### 330D HDHW LRE Long

### 385C L LRE Long

	330D HDHW LRE Long	385C L LRE Long
Undercarriage	Heavy Duty High Wide (HDHW)	Long Variable Gauge (LVG)
Shoes	700 mm	750 mm
Boom Length	10 660 mm	12 500 mm
Stick Length	7100 mm	9500 mm
<b>A</b> Overall Length (Front Folded)	15 310 mm	18 780 mm
<b>B</b> Overall Height (Front Folded)	3595 mm	4280 mm
Overall Width	3620 mm	3500 mm
Operating Weight	36 680 kg	88 490 kg

**Long Reach Excavation Lift Capacities at Ground Level**

Lift Capacities at Ground Level		3 m		4.5 m		6 m		7.5 m		9 m	
		Front Load	Side Load	Front Load	Side Load	Front Load	Side Load	Front Load	Side Load	Front Load	Side Load
<b>330D HDHW LRE Long</b>	<b>kg</b>	2250*	2250*	4850*	4850*	9940*	8610	7490*	6340	5940*	4880
<b>385C L LRE Long</b>	<b>kg</b>	5480*	5480*	9290*	9290*	16 720*	16 720*	18 040*	17 340	14 370*	13 490

Lift Capacities at Ground Level		10.5 m		12 m		13.5 m		15 m		16.5 m	
		Front Load	Side Load	Front Load	Side Load	Front Load	Side Load	Front Load	Side Load	Front Load	Side Load
<b>330D HDHW LRE Long</b>	<b>kg</b>	4890*	3860	4040*	3080	3570*	2480	3120*	2000	2680*	1610
<b>385C L LRE Long</b>	<b>kg</b>	11 840*	10 800	10 000*	8780	8800*	7210	7500*	5950	6800*	4910

Lift Capacities at Ground Level		18 m		19.5 m		Max. Reach		Maximum Reach Radius
		Front Load	Side Load	Front Load	Side Load	Front Load	Side Load	
<b>330D HDHW LRE Long</b>	<b>kg</b>	—	—	—	—	1940*	1410	17.62 m
<b>385C L LRE Long</b>	<b>kg</b>	5840*	4050	4340*	3320	3250*	2900	20.77 m

\*Load limited by hydraulic capacity rather than tipping.

## Hydraulic Excavators

### Super Long Reach

- Introduction
- Range Dimensions
- Bucket Information

## INTRODUCTION

Super long reach excavators are designed specifically for those jobs requiring maximum reach well beyond the range of normal excavators. Those machines are designed to drag a small bucket at about 90 degrees over the side of the tracks towards the excavator; they are not suited for digging work. Caterpillar offers the Long Reach excavators for light digging applications with a much larger digging envelope than normal excavators. Super long reach excavators are suited for ditch cleaning, slope finishing, river conservation and other work formerly reserved to draglines.

Caterpillar's super long reach hydraulic excavators use purpose-built booms and sticks designed by Caterpillar for maximum performance and durability in dragging applications.

Super long reach fronts include: boom, stick, linkage cylinders (boom, stick, and bucket), hydraulic lines and additional counterweight for stability while working over the side. Dimensions include bucket.

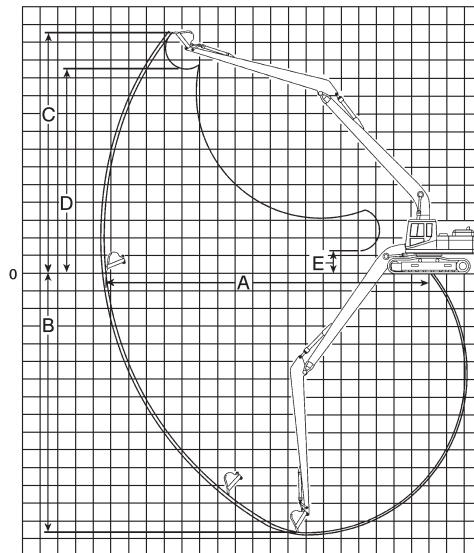

Super Long Reach, Range Dimensions	312C L*		315C L, 317B L*		320D2 L		326D2 L	
	m	ft	m	ft	m	ft	m	ft
<b>A</b> Maximum Reach at Ground Level	12.54	41'2"	13.00	42'8"	15.72	51'7"	18.30	60'0"
<b>B</b> Maximum Digging Depth	9.80	32'2"	10.10	33'2"	11.87	38'11"	14.59	47'10"
<b>C</b> Maximum Cutting Height	10.96	35'11"	11.64	38'2"	13.30	43'8"	14.19	46'7"
<b>D</b> Maximum Dumping Height	9.01	29'9"	9.58	31'5"	11.02	36'2"	12.13	39'10"
<b>E</b> Minimum Loading Height	2.15	7'1"	2.55	8'4"	1.97	6'6"	1.48	4'10"

## Super Long Reach, Bucket Information

Model	Bucket Type	Bucket Width		SAE Heaped Cap.		Bucket Weight		No. of Teeth	Bucket Curl Force		Stick Crowd Force	
		mm	ft	L	yd <sup>3</sup>	kg	lb		kN	lb	kN	lb
312C*	Ditch Cleaning	920	3'0"	480	0.63	230	510	4	44	9900	37	8300
320D2 L	Ditch Cleaning	1140	3'9"	450	0.60	290	640	0	54	12,185	48	10,813
326D2 L	Ditch Cleaning	1140	3'9"	600	0.78	290	640	0	61	13,600	45	10,152

\*Custom product.

- Super Long Reach
- Shipping Dimensions
- Major Component Weights

## Hydraulic Excavators

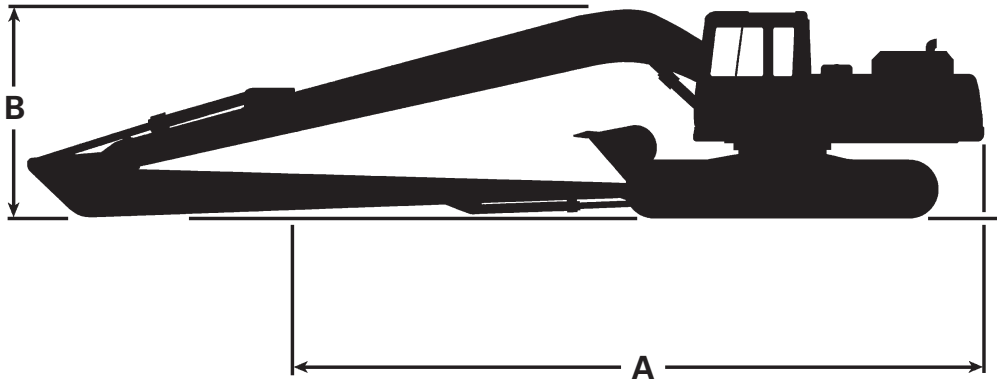

7

Super Long Reach, Shipping Dimensions	312C*		315D L*		320D2 L		326D2 L	
	m	ft	m	ft	m	ft	m	ft
<b>A</b> Overall Length (Front Folded)	10.22	<b>33'6"</b>	11.23	<b>36'10"</b>	12.68	<b>41'7"</b>	14.34	<b>47'1"</b>
<b>B</b> Overall Height	2.80	<b>9'2"</b>	2.92	<b>9'7"</b>	3.05	<b>10'0"</b>	3.15	<b>10'4"</b>
<b>C</b> Overall Width	2.76	<b>9'1"</b>	2.75	<b>9'0"</b>	3.17	<b>10'5"</b>	3.38	<b>11'1"</b>

Super Long Reach, Component Weights	312C*		315D L*		320D2 L		326D2 L	
	kg	lb	kg	lb	kg	lb	kg	lb
Total Component Weight Includes additional over standard	2450	<b>5400</b>	3050	<b>6725</b>	4840	<b>10,670</b>	6950	<b>15,320</b>
Long Reach Boom	1140	<b>2510</b>	1210	<b>2670</b>	2350	<b>5180</b>	3130	<b>6900</b>
Long Reach Stick	640	<b>1410</b>	780	<b>1720</b>	1020	<b>2250</b>	1560	<b>3440</b>

\*Custom product.



# Hydraulic Excavators

## Short Reach

- Range Dimensions
- Front Attachment Information

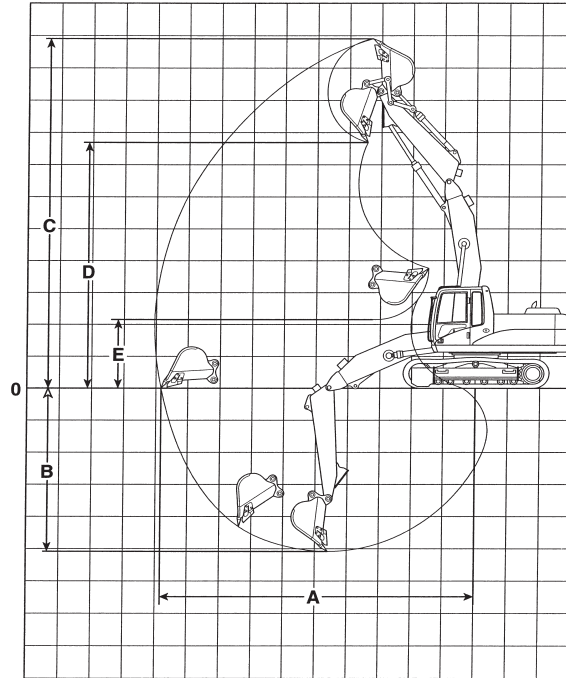

### Short Reach, Range Dimensions

	314C CR*		336D L*	
	m	ft	m	ft
<b>A</b> Maximum Reach at Ground Level	6.54	21'5"	8.88	29'2"
<b>B</b> Maximum Digging Depth	8.15	26'9"	9.95	32'8"
<b>C</b> Maximum Cutting Height	2.22	7'3"	3.76	12'4"
<b>D</b> Maximum Dumping Height	5.56	18'3"	6.64	21'9"
<b>E</b> Minimum Loading Height	1.91	6'3"	1.80	5'11"

### Short Reach, Front Attachment Information

Model	Boom Length		Stick Length		Heaped Capacity	
	mm	ft	mm	ft	L	yd <sup>3</sup>
314C CR*	3200	10'6"	2400	7'10"	500	0.7
336D L*	4350	14'3"	3200	10'6"	1400	1.83

\*Custom product.

- Short Reach
- Shipping Dimensions
  - Major Component Weights

## Hydraulic Excavators

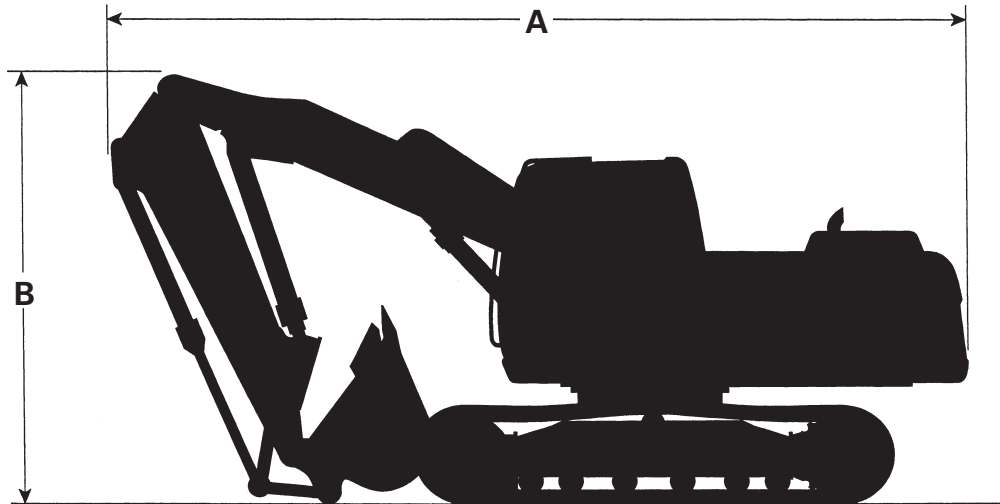

7

### Short Reach, Shipping Dimensions

	314C CR*		336D L*	
	m	ft	m	ft
<b>A</b> Overall Length (Front Folded)	5.35	17'7"	8.27	27'2"
<b>B</b> Overall Height	2.73	8'11"	3.87	12'8"
<b>C</b> Overall Width	2.49	8'2"	3.35	11'0"

### Short Reach, Component Weights

	314C CR*		336D L*	
	kg	lb	kg	lb
Total Component Weight Includes additional over standard	3350	7390	6000	13,230
Short Reach Boom	1140	2510	2170	4780
Short Reach Stick	600	1320	1300	2870

\*Custom product.

- Tracks vs. Wheels
- Stick/Bucket Combinations

### MACHINE SELECTION: TRACKS VERSUS WHEELS

#### Features:

##### Tracks

- Flotation
- Traction
- Maneuverability
- Severe underfoot
- Faster machine repositioning

##### Wheels

- Mobility and speed
- No pavement damage
- Better stability with outriggers or dozers
- Leveling machine with outriggers
- Dozing capability

#### 307–385

Unless the application calls for a lot of travel to, from, and around the job sites, a track-type excavator could be the better choice. Track-type excavators provide good traction and flotation in almost all kinds of underfoot conditions. Consistently good drawbar power provides excellent maneuverability. The tracked undercarriage also provides good overall stability. If the job calls for frequent machine repositioning, a track-type excavator will provide better operating efficiency — where raising and lowering outriggers would take extra time.

#### Wheels (M313D–M322D)

Looking for a highly versatile machine? A machine that can do more than mass excavation and trenching. Consider a Wheel Excavator.

A Wheel Excavator combines traditional excavator features such as 360° swing, long reach, deep digging depth, high loading height, high digging forces and high lift capacities, with the mobility of a wheeled undercarriage. The rubber tires allow the excavator to travel paved

roads, work in shopping malls, squares, parking lots and other paved areas without damaging the pavement. It's mobility allows fast independent travel between job sites as well as on the job site giving you more job planning flexibility. The Wheel Excavator is the ideal tool for truck loading in tight quarters, undercutting concrete or asphalt, patching, shoulder work, curb and gutter repair, landscaping, spreading top soil, fine grading, laying pipe, placing manholes or ditch cleaning.

A Wheel Excavator is also an ideal machine in material handling. It can load or unload trucks and carry loads around the job site. Stabilizers and a dozer blade can be pinned to the undercarriage increasing the machines stability during lifting.

Equip the Wheel Excavator with dedicated special attachments such as cab riser, material handling stick and boom. Add the additional hydraulic circuit option and your ready for a complete range of special tools. Ditch cleaning bucket, clamshell, grapples, hammers to name a few.

Cat Wheel Excavators offer a load independent, load-sensing, flow distribution hydraulic system that gives the operator absolute precision and control no matter what the application.

Machine weight is the key to selecting a Wheel Excavator. Following are some additional factors that need to be considered.

Choose the proper boom and stick for your reach, digging depth and lifting requirements. Stability can be greatly enhanced by adding outriggers and/or a dozer blade. Additional hydraulic circuits can be added depending on your application and stick end attachments.

#### Acceptable Bucket/Stick Combinations

The following charts identify the acceptable bucket and stick combinations for Cat Wheel Excavators and are based on stability. Minimum stability occurs with the linkage oriented over the side and positioned as shown in the visual. Dozer and/or stabilizers (if equipped) are raised and the bucket contains a full load. The longest stick is shown that has acceptable stability for each bucket. That stability is 1.1 moment ratio or better. Once this stability factor is established, all shorter sticks are then acceptable with the listed bucket.

## EXCAVATOR SHOE SELECTION

Undercarriage life can be extended by equipping the machine properly for the application.

Many excavators work on pavement or flat, soft ground and experience few undercarriage problems. But if those same machines (usually equipped with wide track pads) were placed in severe underfoot conditions, undercarriage destruction could occur very rapidly.

The rule, used for other track-type machines — *“Whenever possible use the narrowest shoes available”* — is even more valid for excavators.

The best general purpose track shoe is the triple grouser. It has a good section modulus and offers the best compromise between traction and minimum disturbance to paved surface.

The double grouser shoe has a better section modulus and is more aggressive than the triple grouser section. Single grouser shoes are offered for maximum traction. Some users like single grousers for added mobility in hilly terrain.

The following table lists ground pressures for various width shoes (reach boom, medium stick and bucket):

Model	Shoe Type	Shoe Width		Pressure	
		mm	in	kPa	psi
<b>300.9D</b>	Rubber Belt	180	7	24.10	3.50
<b>301.4C</b>	Rubber Belt	230	9	—	—
<b>301.7D</b>	Rubber Belt	230	9	29.42	4.27
<b>301.7D CR</b>	Rubber Belt	230	9	27.50	3.98
<b>302.2D</b>	Rubber Belt	250	10	28.44	4.13
<b>302.4D</b>	Rubber Belt	250	10	28.44	4.13
<b>302.7D CR</b>	Rubber Belt	300	12	—	—
<b>303E CR</b>	Steel Double Grouser	300	12	—	—
	Rubber Belt	300	12	32.20	4.60
<b>303.5E CR/303.5E2 CR</b>	Steel Double Grouser	300	12	—	—
	Rubber Belt	300	12	32.10	4.70
<b>304E CR/304.5E2 XTC</b>	Steel Double Grouser	350	14	—	—
	Rubber Belt	350	14	29.60	4.30
<b>305E2 CR</b>	Steel Triple Grouser	400	16	—	—
	Rubber Belt	400	16	30.50	4.40
<b>305.5E2 CR</b>	Steel Triple Grouser	400	16	—	—
	Rubber Belt	400	16	31.90	4.60
<b>307E2</b>	Steel Triple Grouser	450	18	36.80	5.30
<b>308E2 CR SB/ 308E2 VAB</b>	Steel Triple Grouser	450	18	36.80	5.30
	Rubber Belt	450	18	36.80	5.30
	Steel Triple Grouser	600	24	27.00	3.90

Model	Shoe Type	Shoe Width		Pressure	
		mm	in	kPa	psi
<b>311F L RR</b>	Triple	500	20	40.1	<b>5.80</b>
	Triple	600	24	34.0	<b>4.90</b>
	Triple	700	28	29.8	<b>4.30</b>
	Triple	770	30	27.3	<b>4.00</b>
<b>312D2</b>	Triple	500	20	41.7	<b>6.05</b>
	Triple	600	24	35.5	<b>5.15</b>
	Triple	700	28	31.0	<b>4.50</b>
	Triple	770	30	28.4	<b>4.12</b>
<b>312D2 L</b>	Triple	500	20	39.4	<b>5.71</b>
	Triple	600	24	33.3	<b>4.83</b>
	Triple	700	28	29.2	<b>4.24</b>
	Triple	770	30	26.7	<b>3.87</b>
<b>313D2</b>	Triple	500	20	43.4	<b>6.29</b>
<b>312D2 GC</b>	Triple	500	20	40.4	<b>5.86</b>
<b>312E</b>	Triple	500	20	42.4	<b>6.15</b>
	Triple	600	24	36.1	<b>5.24</b>
	Triple	700	28	31.4	<b>4.56</b>
	Triple	770	30	28.8	<b>4.18</b>
<b>312E L</b>	Triple	500	20	40.2	<b>5.83</b>
	Triple	600	24	34.1	<b>4.94</b>
	Triple	700	28	29.8	<b>4.32</b>
	Triple	770	30	27.3	<b>3.97</b>
<b>312F GC</b>	Triple	500	20	40.4	<b>5.90</b>
	Triple	700	28	30.0	<b>4.40</b>
<b>313D2 LGP</b>	Single	960	38	23.7	<b>3.44</b>
<b>313F L GC</b>	Triple	500	20	39.7	<b>5.80</b>
	Triple	600	24	33.1	<b>4.80</b>
	Triple	700	28	29.4	<b>4.30</b>
<b>314E CR</b>	Triple	500	20	43.2	<b>6.27</b>
	Triple	600	24	36.5	<b>5.32</b>
	Triple	700	28	31.9	<b>4.63</b>
<b>314E LCR</b>	Triple	500	20	43.2	<b>6.27</b>
	Triple	600	24	36.5	<b>5.29</b>
	Triple	700	28	31.9	<b>4.63</b>
<b>316E L</b>	Triple	500	20	49.0	<b>7.10</b>
	Triple	600	24	42.0	<b>6.09</b>
	Triple	700	28	36.0	<b>5.22</b>

Model	Shoe Type	Shoe Width		Pressure	
		mm	in	kPa	psi
<b>318D2 L</b>	Triple	500	20	48.3	7.01
	Triple	600	24	40.8	5.92
	Triple	700	28	35.8	5.19
<b>318E L</b>	Triple	500	20	52.0	7.54
	Triple	600	24	43.0	6.24
	Triple	700	28	38.0	5.51
<b>320D2</b>	Triple	600	24	46.8	6.80
	Triple	700	28	40.8	5.90
	Triple	790	31	36.2	5.30
<b>320D2 GC</b>	Triple	600	24	47.5	6.90
	Triple	790	31	37.1	5.40
<b>320D2 L</b>	Triple	600	24	43.5	6.30
	Triple	700	28	38.0	5.50
	Triple	790	31	33.6	4.90
<b>320E</b>	Triple	600	24	47.9	6.95
	Triple	700	28	41.8	6.06
	Triple	790	31	37.5	5.44
<b>320E L</b>	Triple	600	24	44.9	6.51
	Triple	700	28	39.1	5.67
	Triple	790	31	35.1	5.09
<b>320E RR</b>	Triple	600	24	53.0	7.69
	Triple	700	28	46.1	6.68
	Triple	790	31	41.3	5.99
<b>320E LRR</b>	Triple	600	24	59.9	8.69
	Triple	700	28	52.1	7.55
	Triple	790	31	46.6	6.76
<b>320F L</b>	Triple	600	24	45.0	6.53
	Triple	700	28	39.3	5.70
	Triple	790	31	35.2	5.10
<b>323F L</b>	Single	600	24	47.2	6.85
	Triple	790	31	36.3	5.27
<b>323F LN</b>	Triple	500	20	55.6	8.06

NOTE: Belgium sourced excavators have different ground pressures. See Technical Data Sheets.

Model	Shoe Type	Shoe Width		Pressure	
		mm	in	kPa	psi
<b>325F L</b>	Triple	600	24	40.9	5.90
	Triple	790	31	52.7	7.60
<b>326D2 L</b>	Triple	600	24	50.7	7.40
	Double	600	24	51.3	7.40
	Triple	790	31	39.4	5.70
<b>326F L</b>	Triple	600	24	49.8	7.20
	Triple	790	31	38.9	5.60
	Triple	900	35	34.7	5.00
<b>330D2 L</b>	Triple	600	24	54.8	7.90
	Double	600	24	55.6	8.10
	Triple	700	28	47.5	6.90
	Triple	800	32	42.5	6.20
<b>330F L</b>	Triple	600	24	54.3	7.90
	Double	600	24	55.2	8.00
	Triple	700	28	47.1	6.80
	Triple	800	32	42.1	6.10
	Triple	900	35	37.9	5.50
<b>335F L</b>	Triple	600	24	64.9	9.40
	Triple	850	33	47.5	6.90
<b>336D2</b>	Triple	600	24	71.5	10.37
	Triple	700	28	61.9	8.98
	Triple	800	32	55.1	8.00
<b>336D2 L</b>	Triple	600	24	66.1	9.59
	Triple	700	28	57.2	8.30
	Triple	800	32	51.0	7.40
<b>336D2 – ES</b>	Triple	600	24	71.0	10.30
<b>336E L</b>	Triple	600	24	67.1	9.70
	Triple	700	28	58.0	8.40
	Triple	800	32	51.7	7.50
	Triple	850	34	49.0	7.10
<b>336E LN</b>	Triple	600	24	66.5	9.60
	Triple	700	28	57.5	8.30
<b>336E L H</b>	Triple	600	24	66.5	9.60
	Triple	700	28	57.5	8.30
	Triple	800	32	51.3	7.40
	Triple	850	34	48.7	7.10

NOTE: Belgium sourced excavators have different ground pressures. See Technical Data Sheets.

Model	Shoe Type	Shoe Width		Pressure	
		mm	in	kPa	psi
<b>336E LN H</b>	Triple	600	<b>24</b>	66.1	<b>9.60</b>
	Triple	700	<b>28</b>	57.3	<b>8.30</b>
<b>336F L</b>	Triple	600	<b>24</b>	67.8	<b>9.80</b>
	Triple	700	<b>28</b>	58.6	<b>8.50</b>
	Triple	800	<b>32</b>	52.2	<b>7.60</b>
	Triple	850	<b>34</b>	49.6	<b>7.20</b>
<b>349D2</b>	Triple	750	<b>30</b>	66.3	<b>9.63</b>
	Double	750	<b>30</b>	66.3	<b>9.63</b>
<b>349D2 L</b>	Triple	600	<b>24</b>	76.8	<b>11.14</b>
	Triple	750	<b>30</b>	62.5	<b>9.07</b>
	Triple	900	<b>35</b>	53.0	<b>7.67</b>
	Double	600	<b>24</b>	77.0	<b>11.16</b>
<b>349F L</b>	Double	600	<b>24</b>	84.0	<b>12.20</b>
	Triple	750	<b>30</b>	68.0	<b>9.90</b>
	Triple	900	<b>35</b>	58.0	<b>8.40</b>
<b>352F</b>	Double	600	<b>24</b>	89.0	<b>12.90</b>
	Triple	750	<b>30</b>	72.0	<b>10.40</b>
	Triple	900	<b>35</b>	61.0	<b>8.80</b>
<b>374F L*</b>	Double	650	<b>26</b>	105.5	<b>15.30</b>
	Double	750	<b>30</b>	92.3	<b>13.40</b>
	Double	900	<b>35</b>	78.0	<b>11.30</b>
<b>390F L**</b>	Double	650	<b>26</b>	119.4	<b>17.30</b>
	Double	750	<b>30</b>	104.5	<b>15.20</b>
	Double	900	<b>35</b>	88.1	<b>12.78</b>

\*Reach boom 7.8 m (25'7"); 3.8 m<sup>3</sup> (5.0 yd<sup>3</sup>) GD bucket; R4.67m (15'4") stick.

\*\*Reach boom 10.0 m (32'10"); 3.9 m<sup>3</sup> (5.1 yd<sup>3</sup>) GD bucket; R5.5m (18'1") stick.

NOTE: Belgium sourced excavators have different ground pressures. See Technical Data Sheets.



### **QUICK COUPLER SYSTEMS**

Quick couplers can greatly increase a machine's versatility and productivity. They make it much easier to switch attachments which can increase utilization. Quick couplers also encourage changing buckets when the application changes, rather than continue to use a less efficient bucket. Example: An application that is predominately dirt with occasional pockets or seams of rock. Without a quick coupler the owner may choose to live with a rock bucket but, rock buckets are normally smaller and heavier which reduces performance in a dirt application. A quick coupler allows the use of the rock bucket in the rock and a GP bucket in the dirt.

Caterpillar offers two main types of quick couplers. The first is a dedicated type. A typical system substitutes hooks on the bucket for the pin-on hinges used with conventional buckets. The mating portion is pinned on the stick and bucket linkage. It slips into the hooks to secure the bucket or other attachment.

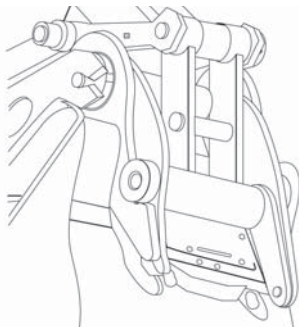

**Dedicated  
Hook-type**

#### **Advantages:**

Bucket tip radius (distance from the bucket pivot point to the bucket tip) does not increase. Increased tip radius reduces curl and stick forces which can reduce the loadability of the bucket. The hook type coupler also does not add appreciable weight at the end of the stick. Keeping the tip radius and weight the same ensure no compromise in performance. The machine portion of the hook type coupler can be designed to allow more than one machine to use the same buckets.

#### **Disadvantages:**

The hook type system requires special buckets. Conventional pin-on buckets cannot be used. The ability to use buckets on more than one machine requires careful application analysis. Larger machines generate forces that can destroy the wrong buckets. Smaller machines with the wrong bucket may develop loads in excess of the machine's capability. Even if the machine can handle the loads, the tip radius may be too large to allow the bucket to load properly. With the flexibility of a quick coupler comes the responsibility to make sure the bucket or other attachments are properly sized for each application.

The second type of quick coupler is the pin grabber type. This device pins on the stick and bucket linkage and grabs the bucket pins on standard pin-on buckets.

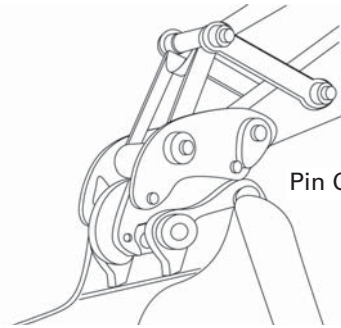

**Pin Grabber**

#### **Advantages:**

The advantage of the pin grabber is that it will pick up standard pin-on buckets. No need to purchase new attachments that will fit the system.

#### **Disadvantages:**

The pin grabber is mounted between the stick and the bucket which increases the tip radius. The amount of increase depends on the pin grabber's manufacturer. Increasing tip radius can compromise performance by decreasing bucket forces. The coupler also adds weight and reduces the payload capability.

Pin grabbers are required to mate up with existing bucket pins. Because different machines require different pin spreads and diameters, they offer very limited ability to match with buckets from other machines.

Both types of quick couplers offer cab activated ... this allows an attachment change in 30 seconds or less.

## MINI HYDRAULIC EXCAVATORS

### Dual Lock Pin Grabber Couplers

Dual Lock Pin Grabber Couplers allow work tools to be changed quickly — improving overall production and increasing machine versatility. A coupler is pinned on in place of the bucket with standard pins.

The **Dual Lock Coupler** is available in a standard pin grabber design for use on machines sized from 301.4C-308E2 CR SB. There are two types of Dual Lock Pin Grabber Couplers – Mechanical and Hydraulic (fully operable from the cab).

The **Dual Lock Tilt Coupler** allows for 180° of rotation while providing a reliable high torque actuator with few moving parts. The 180° rotation reduces the need for additional equipment on the job site, while increasing productivity and profitability.

### Visible Secondary Lock

Cat Dual Lock Pin Grabber Couplers maintain a tight fit throughout the life of the coupler with an innovative wedge design. Primary and secondary locking systems are totally independent. The primary locking system consists of a locking wedge mechanism. An anti-rotation locking system into the actuator for the primary locking wedge is automatic and ensures the primary lock remains fully engaged even when used with high energy vibratory tools.

The secondary locking system incorporates a spring-loaded rotating lock that automatically locks on the front pin on the work tool during coupling. Spring applied, hydraulically released on the hydraulic coupler, and spring applied, mechanically released on the mechanical coupler.

Dual Lock Couplers were designed with the operator in mind allowing the secondary lock to be clearly visible from the cab.

### Productivity

As with any quick coupler, the Dual Lock quickly changes between attachments, allowing one machine to be used for multiple tasks on the job site. The ability to see when the coupler is open or closed makes it intuitive to use, saving time when changing tools.

Dual Lock Couplers can engage and disengage any compatible Cat bucket or work tool attachment equipped with pins. The pin grabber design allows for buckets to be turned around in “front shovel” mode on both the Dual Lock and the Dual Lock Tilt Coupler.

The ease of operation and quickness of tool change-over maximizes productivity on the job site. The coupler is easy to operate, regardless of user skill level, and it's easier to train new operators to use. The ability to see when the coupler is open and closed saves time whenever a tool is changed. The elimination of the locking bar allows for operation regardless of boom, stick and machine position.

Dual Lock Pin Grabber Couplers meet Australian Standard AS 4772 and European EN-474-1.

Pin grabber couplers allow work tools to be changed quickly — improving overall production and increasing machine versatility. A coupler is pinned on in place of the bucket with standard pins, and can be easily removed should the need arise to mount a tool directly to the stick.

The Pin Grabber Coupler is designed for use on machines sized from 311-385 — and is designed to engage and disengage the same range of work tools as previous pin grabber couplers.

No dimensional or interface changes have been made to this coupler. However, a new patent-pending concept in the locking mechanism inside Center-Lock brings many benefits to the operator.

**Compliant**

The Cat Pin Grabber Coupler gives operators confidence through its patent pending locking system and visible locking mechanism. Couplers meet or exceed latest EN and ISO safety standards: EN474 and ISO/DIS 13031.

**Visible Secondary Lock**

The Pin Grabber Coupler was designed with the operator in mind. The secondary lock is clearly visible from the cab, providing an obvious indicator of coupler status: open or closed. The ability to see the lock on the front pin give the operator confidence and makes changing tools faster, while giving everyone on the job site reassurance that the Pin Grabber is locked tight.

**Job Site Confidence**

From engagement, all while working, to the time the attachment is disengaged, you can be completely confident attachments are connected properly.

From the operator's seat, visual and audible indicators help assure attachment is coupled. Your Cat excavator hydraulics, mechanisms inside the coupler, along with digging forces assure the attachment operates as expected.

The Cat Pin Grabber Coupler meets and exceeds safety standards allowing you to work anywhere in the world.

**Productivity**

As with any quick coupler, the Pin Grabber changes between attachments in seconds, allowing one machine to be used for multiple tasks on the job site.

The ease of operation and quickness of tool change-over maximizes productivity on the job site. The coupler is easy to operate, regardless of user skill level, and it's easier to train new operators to use. The ability to see when the coupler is open and closed saves time whenever a tool is changed. The elimination of the locking bar allows for operation regardless of boom, stick and machine position.

The Pin Grabber Coupler can pick up many buckets in reverse "front shovel" position for better control in utility work and precise digging and grading operations. Many competitive buckets can be engaged, making the Cat Pin Grabber invaluable in mixed fleets or rental fleets.

The Cat CW quick coupler can pick up any work tool and is equipped with a wedge-style locking system minimizing break-out force loss. The CW is highly suitable for harsh applications, such as demolition and quarries. The CW has become the industry standard in EAME. It is interchangeable with different machine classes, and has been designed for use with more than 700 different machines, both Cat and non Cat.

The Cat CW Series is available in a spindle and hydraulic version. A spindle version can easily be modified into a hydraulic version and vice versa.

**Additional Benefit:**

**Hoisting hooks** — To make the CW Series more versatile, hoisting hooks are available from 2 metric tons (2.2 tons) up to 20 metric tons (22 tons) capacity for maximum lifting capacity.

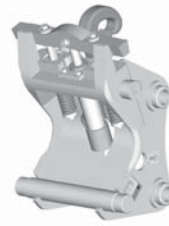

Hydraulic Version

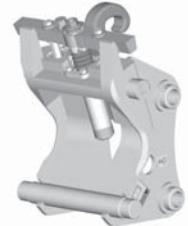

Spindle Version

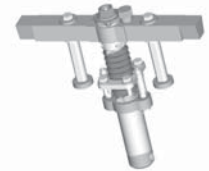
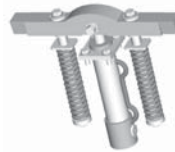

**Specifications**

		CW-05	CW-10	CW-20	CW-20S	CW-30	CW-30S			
Weight	kg	25	75	190	180	230	220			
	lb	55	165	419	397	507	485			
Dimensions										
	Width	mm	175	310	550	420	550	420		
		in	6.9	12.2	21.7	16.5	21.7	16.5		
Length	mm	200	300	475	475	475	475			
	in	7.9	11.8	18.7	18.7	18.7	18.7			
Hoisting-hook	metric ton	2	4	5/10	5/10	5/10	5/10			
	ton	2.2	4.4	5.5/11.0	5.5/11.0	5.5/11.0	5.5/11.0			
Excavator-class	metric ton	<3.5	3.5-10.5	7.5-15	7.5-15	15-25	15-25			
	ton	<3.9	3.9-11.6	8.3-16.5	8.3-16.5	16.5-27.6	16.5-27.6			
Spindle Version		X	X	X	X	X	X			
Hydraulic Version		X	X	X	X	X	X			
		CW-40	CW-40S	CW-45	CW-45S	CW-55	CW-55S	CW-70		
Weight	kg	240	230	440	400	760	580	1300		
	lb	529	507	970	882	1676	1279	2866		
Dimensions										
	Width	mm	550	420	690	550	830	560	840	
		in	21.7	16.5	27.2	21.7	32.7	22.0	33.1	
Length	mm	475	475	570	570	650	650	875		
	in	18.7	18.7	22.4	22.4	25.6	25.6	34.4		
Hoisting-hook	metric ton	5/10	5/10	14	14	20	20	20		
	ton	5.5/11.0	5.5/11.0	15.4	15.4	22.0	22.0	22.0		
Excavator-class	metric ton	20-30	20-30	25-40	25-40	35-65	35-65	65-90		
	ton	22.0-33.1	22.0-33.1	27.6-44.1	27.6-44.1	38.6-71.7	38.6-71.7	71.7-99.2		
Spindle Version		X	X	X	X	X	X	N/A		
Hydraulic Version		X	X	X	X	X	X	X		

CW-40 and CW-40S are not suitable for machine exceeding 27 metric tons (29.8 ton), which are used under heavy working conditions like rocky soils and demolition work, we highly recommend the usage of quick coupler CW-45(S).

### Matching Guide

Machine	Linkage Family	Quick Coupler Model	
		Standard	Narrow
300.9D		—	N/A
301.4C		CW-05	N/A
301.7D		CW-05	N/A
301.7D CR		CW-05	N/A
302.2D		CW-05	N/A
302.4D		CW-05	N/A
302.7D CR		CW-05	N/A
303.5E CR		CW-05	N/A
304E2 CR		CW-05	N/A
305E2 CR		CW-05	N/A
305.5E2 CR		CW-05	N/A
312D		CW-20	CW-20S
315D L		CW-30	CW-30S
319D		CW-30	CW-30S
320D	B1, CB	CW-40	CW-40S
320D RR	B1	CW-40	N/A
321D CR	B1	CW-40	N/A
323D L	B, C	CW-40	CW-40S
329D**	C	CW-40	CW-40S
329D	D	CW-45	CW-45S

Machine	Linkage Family	Quick Coupler Model	
		Standard	Narrow
336D	D	CW-45	CW-45S
336D	E	CW-45	CW-45S
349D2/349E	TB, UB	CW-55	CW-55S
365C L	VB, WB	CW-70	N/A
385C	HJ, JB	CW-70	N/A
M314F		CW-20	CW-20S
M316F		CW-20	CW-20S
M318F		CW-20	CW-20S
M320F		CW-30	CW-30S
M322F		CW-40	CW-40S
330C UHD*	UHD linkage	CW-40	CW-40S
345C L UHD*	UHD linkage	CW-40	CW-40S
365C L UHD*	UHD linkage	CW-40	CW-40S
385C L UHD*	UHD linkage	CW-40	CW-40S

\*Take note that UHD quick couplers have a special shape for optimal working range with Cat demolition work tools. Please contact your Cat dealer for UHD couplers for non-current Cat machines.

\*\*For operation under heavy working conditions, like rocky soils and demolition work, we highly recommend the usage of quick coupler CW-45(S).

### Machine Linkage

		312	315	B1	S	C	D	F/T	U/V/G
Pin diameters									
Front (stick)	mm	65	70	80	80	80	90	100	110
	in	2.6	2.8	3.1	3.1	3.1	3.5	3.9	4.3
Rear (link)	mm	65	70	80	80	80	90*	100**	90**
	in	2.6	2.8	3.1	3.1	3.1	3.5*	3.9**	3.5**
Pin spread range									
Minimum	mm	360	390	441	441	470	470	550	580
	in	14.2	15.4	17.4	17.4	18.5	18.5	21.7	22.8
Maximum	mm	420	463	516	516	520	520	600	640
	in	16.5	18.2	20.3	20.3	20.5	20.5	23.6	25.2
Face spread range									
Minimum	mm	220	277	306	306	347	380	420	495
	in	8.7	10.9	12.0	12.0	13.7	15.0	16.5	19.5
Maximum without shims	mm	226	281	312	312	353	386	441	511
	in	8.9	11.1	12.3	12.3	13.9	15.2	17.4	20.1
Maximum with shims	mm	258	315	344	344	385	418	458	557
	in	10.2	12.4	13.5	13.5	15.2	16.5	18.0	21.9
Other specifications									
Weight with pins	kg	286	326	443	443	594	640	1035	1130
	lb	631	719	977	977	1310	1411	2282	2491
Weight without pins	kg	265	295	400	400	549	579	949	1025
	lb	584	650	882	882	1210	1276	2092	2260
Pressure rating	bar	400	400	400	400	400	400	400	400
	psi	5802	5802	5802	5802	5802	5802	5802	5802

\*Requires (2) sleeves.

\*\*Requires (3) sleeves.

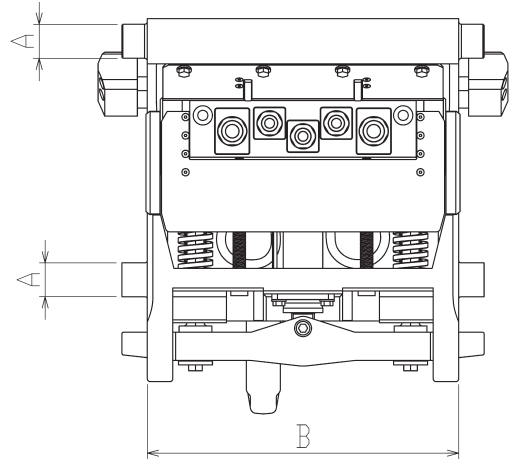
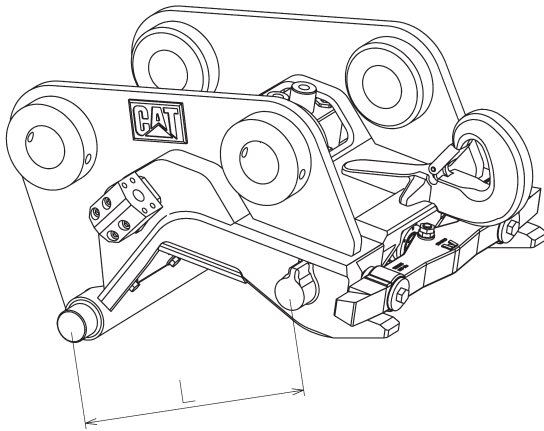

### Auto-Connect Quick Coupler

The Auto-Connect quick coupler automates tool exchange fully, so operators can change work tools quickly, from the safety and comfort of their cabs. Tool changes become a matter of seconds. Built on the field proven quick coupler CW platform, the unique design of the Auto-Connect prevents ruptured hoses and oil spills, avoiding unplanned downtime.

### Full Contamination Control on Both Quick Coupler and Work Tool:

A sliding cover keeps any dust and debris away from the hydraulic area, protecting the fluid connectors when not in use. Seals on both the Quick Coupler and the work tool cover have been included to close the gap with the cartridges, ensuring full contamination control. Rigid work tools without hydraulics, like buckets, do not need conversion to be picked up by the Auto-Connect quick coupler, avoiding unnecessary expenses. Due to the location of the hydraulic coupling unit, it's protected against damage from outside.

### Plug-and-Perform System:

Auto-Connect is a “plug-and-perform” system based on Caterpillar’s dedicated CW platform, and fits directly to the machine and existing controls. The Auto-Connect is controlled via the Quick coupler actuation circuit. Combined with Cat Tool Control, it’s really easy for operators to select tools and make fast changeovers. With features like Auto Depressurization as standard no additional hydraulic components are required.

### Specifications for Cat Wedge Auto-Connect Quick Coupler

		CWAC-40
Weight (approximate)	kg	340
	lb	750
QC-pins (A)	mm	60
	in	2.4
Width (B)	mm	550
	in	21.7
Length (L)	mm	475
	in	18.7
Hoisting-hook	metric ton	10
	ton	11
Total Fluid Connectings		5
Hose Couplings High Flow		2× 1"
Hose Couplings Medium Flow		2× 1/2"
Hose Couplings Extra/Drain		1× 1/2"

CWAC-40 is interchangeable with CW-30 and CW-40.

Please note that the coupler and the tools have to match the correct carrier.

### Matching Guide

Quick Coupler	Linkage	Hydraulic Excavators
CWAC-40	—	M315D/M316D
CWAC-40	—	M318D/M322D
CWAC-40	—	315D/316E/318E
CWAC-40	—	319D
CWAC-40	B	320D/320E/321D/323D/323E

**RIPPING & LOADING IN QUARRIES**

The “Rip & Load” concept includes a large mass excavator equipped with a hydraulic quick coupler, a rock bucket and a ripper tine. The ripper tine is used to disrupt the in-situ rock formation, after which same excavator switches to the bucket to load the rock. This system is used where economical, environmental or legal issues prevent or restrict the use of explosives. In these situations, depending on geology, ripping either reduces the amount of explosives necessary, or replaces explosives all together.

**Advantages:**

- Reduction or elimination of blasting costs.
- Reduced safety risks.
- Smaller environmental impact (less noise and vibrations).
- Less exposure to precipitation, resulting in less water damage.
- Less waste (up to 35% reduction).
- Less internal cracks, resulting in higher quality product.
- Work areas can be closer to existing infrastructures.
- Fewer machines and personnel.
- Increased versatility with quick coupler (different buckets, hammers).
- Lower Cost per Ton.

**Rip and Load Hourly Production**

(With Hydraulic Quick Coupler)

<b>Model</b>	<b>Metric Tons/Hour</b>	<b>Short Tons/Hour</b>
345C/345D	150 - 300	<b>165 - 330</b>
365C	200 - 400	<b>220 - 440</b>
385C	300 - 500	<b>330 - 550</b>
5110B	400 - 600	<b>440 - 660</b>
5130B	600 - 800	<b>660 - 880</b>

**Rippability**

Refer to “Tip Selection”, “Estimating Ripping Production” and “Use of Seismic Velocity Charts” in the Track-type Tractors section. This information generally applies to usage of a ripper tine on the mass excavator.

**Rippability Comparison between LHEX and LTTT**

The excavator ripping technique is different from production ripping with a track-type tractor. The track-type tractor pulls the ripper(s) through the rock mass at a constant rate, whereas the excavator uses its stick-and curl forces to break material away from a horizontal or vertical face. Forward visibility in the excavator allows the operator to position the ripper tooth and attack geological discontinuities to assist the ripping process.

In ripping and loading, the ripper is typically used between 15% and 20% of the hour preparing the material. Tool change time, when using the hydraulic quick coupler, is insignificant with 2% to 6%. The remainder of the time is used for loading.

The ripping process improves bucket penetration which will increase service life of the bucket.

**Cat Hydraulic Quick Couplers for Mass Excavators**

Source: Cat Work Tools and Product Solutions — May not be available in all areas

(S) indicates narrow width version

		<b>CW-30 (S)</b>	<b>CW-40 (S)</b>	<b>CW-45 (S)</b>	<b>CW-55 (S)</b>	<b>CW-70</b>
Width	mm	550 (420)	550 (420)	690 (550)	830 (560)	840
	in	<b>21.7 (16.5)</b>	<b>21.7 (16.5)</b>	<b>27.2 (21.7)</b>	<b>32.7 (22.0)</b>	<b>33.1</b>
Length	mm	475	475	570	650	875
	in	<b>18.7</b>	<b>18.7</b>	<b>22.4</b>	<b>25.6</b>	<b>34.4</b>
<b>Models Available</b>						
<b>S – Spindle</b>		S	S	S	S	H
<b>H – Hydraulic</b>		H	H	H	H	
<b>M318F</b>						
<b>320D</b>		B linkage	CB linkage			
<b>322C</b>			S linkage	D linkage		
<b>M322F</b>						
<b>323D</b>		B linkage				
<b>329D</b>				D linkage		
<b>336D</b>						
<b>345D</b>						
<b>365C</b>						
<b>385C</b>						

7

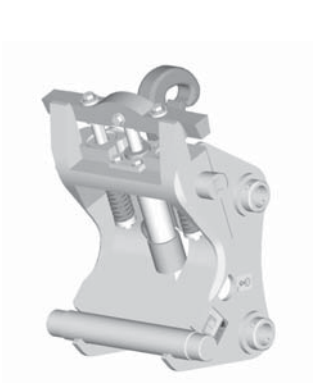

Cat® CW-70  
Quick Coupler

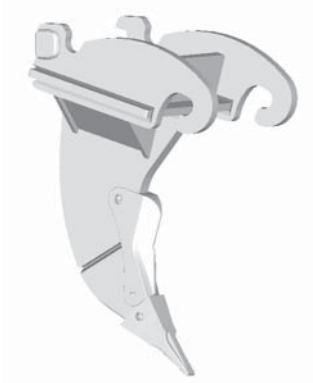

Cat TR-70  
Ripper with QC

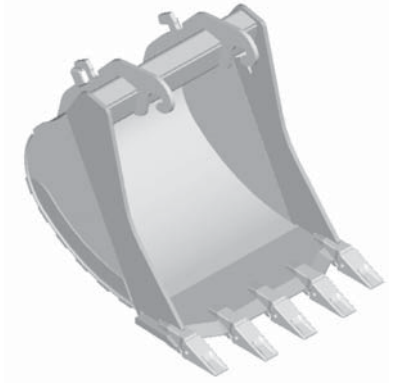

Cat Bucket with  
Quick Coupler Brackets



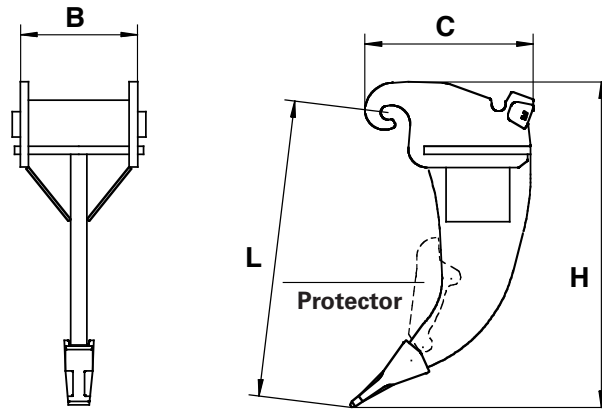

**Specifications**

		TR-20-N		TR-30-N		TR-40-N		TR-45-N		TR-55-N		TR-70-N	TR-99-N
		CA-20	CA-20S	CA-30	CA-30S	CA-40	CA-40S	CA-45	CA-45S	CA-55	CA-55S	CA-70	CA-70
Hinge Plate													
Weight*	kg	300	270	400	370	460	420	820	770	1200	1140	1760	1905
	lb	661	595	882	816	1014	926	1808	1698	2646	2513	3880	4200
Dimensions*													
<b>B</b>	mm	630	500	630	500	630	500	800	660	965	695	1000	1000
	in	24.8	19.7	24.8	19.7	24.8	19.7	31.5	26.0	38.0	27.4	39.4	39
<b>L</b>	mm	940		1105		1270		1435		1600		1700	1778
	in	37.0		43.5		50.0		56.5		63.0		66.9	70
<b>C</b>	mm	725		725		725		900		1050		1325	1452
	in	28.5		28.5		28.5		35.4		41.3		52.2	57
<b>H</b>	mm	1150		1250		1400		1650		1800		1980	2076
	in	45.3		49.2		55.1		65.0		70.9		78.0	82
Wear parts													
Tip size (family)		R300		R350		R450		R500		R500		R550	R550
Shank-protector**		N/A		N/A		X		X		X		X	X
Excavator-class	metric ton	7.5-15		15-25		20-30		25-40		35-65		65-90	90
	ton	8.3-16.5		16.5-27.6		22.0-33.1		27.6-44.1		38.6-71.7		71.7-99.2	99.2

\*Weight and dimensions include standard Quick-Coupler hinge plates and exclude shank-protector.

\*\*Shank-protector is optional.

**Cat Ripper Tine for CW Hydraulic Quick Couplers**

Source: Caterpillar WorkTools and Product Solutions — May not be available in all areas

	TR-30	TR-40	TR-45	TR-55	TR-70	TR-99
320D						
322C						
323D						
329D						
336D						
345D						
365C						
374D						
385C						
390D						JC linkage

Summary of Major Attachments  
 ● 300.9D ● 301.4C ● 301.7D  
 ● 302.2D ● 302.4D ● 302.7D CR

**Hydraulic  
Excavators**

EQUIPMENT FOR ...	300.9D	301.4C	301.7D	301.7D CR
<b>Undercarriage:</b>				
Standard	●	●	●	—
Variable Width	●	●	●	●
<b>Booms:</b>				
Swing	●	●	●	●
<b>Sticks:</b>				
Medium	—	—	●	●
Long	●	●	●	●
<b>Buckets (No. of)</b>	3	10	10	10
<b>Teeth:</b>				
Long	●	●	●	●
<b>Side Cutters:</b>				
One-Piece Blade	●	●	●	●
<b>Track Shoes:</b>	Rubber Belt 230 mm (9")	Rubber Belt 230 mm (9")	Rubber Belt 230 mm (9")	Rubber Belt 230 mm (9")

7

EQUIPMENT FOR ...	302.2D	302.4D	302.7D CR
<b>Undercarriage:</b>			
Standard	●	●	●
Variable Width	—	—	—
<b>Booms:</b>			
Swing	●	●	●
<b>Sticks:</b>			
Medium	●	●	●
Long	●	●	●
<b>Buckets (No. of)</b>	12	12	12
<b>Teeth:</b>			
Long	●	●	●
<b>Side Cutters:</b>			
One-Piece Blade	●	●	●
<b>Track Shoes:</b>	Rubber Belt 250 mm (10")	Rubber Belt 250 mm (10")	Rubber Belt 300 mm (12")

**NOTE:** Number of buckets includes General Purpose, Trenching and Rock. Other types of buckets have not been included.  
 All attachments may not be available in all sales areas.

# Hydraulic Excavators

## Summary of Major Attachments

- 303E CR   ● 303.5E CR   ● 304E CR
- 304.5E2 XTC   ● 305E2 CR

EQUIPMENT FOR ...	303E CR	303.5E2 CR	304E2 CR	304.5E2 XTC	305E2 CR
<b>Undercarriage:</b>					
Standard	●	●	●	●	●
<b>Booms:</b>					
Swing	●	●	●	●	●
<b>Sticks:</b>					
Medium	●	●	●	●	●
Long	—	●	●	●	●
<b>Teeth:</b>					
Long	●	●	●	●	●
Light Duty Long	●	●	●	●	●
Short	—	●	●	●	●
Wide	●	●	●	●	●
Penetration	●	●	●	●	●
Sharp — Corner	●	●	●	●	●
Sharp — Center	●	●	●	●	●
Sharp — Twin	●	●	●	●	●
Heavy Duty Long	—	●	●	●	●
Heavy Duty Abrasion	—	●	●	●	●
Abrasion	●	●	●	●	●
<b>Side Cutters:</b>					
One-Piece Blade	●	●	●	●	●
<b>Track Shoes:</b>	Triple Grouser 300 mm (12") Rubber Belt 300 mm (12")	Triple Grouser 300 mm (12") Rubber Belt 300 mm (12")	Triple Grouser 350 mm (14") Rubber Belt 350 mm (14")	Triple Grouser 350 mm (14") Rubber Belt 350 mm (14")	Triple Grouser 400 mm (16") Rubber Belt 400 mm (16")

**NOTE:** Number of buckets includes General Purpose, Trenching and Rock. Other types of buckets have not been included.  
All attachments may not be available in all sales areas.

<b>EQUIPMENT FOR ...</b>	<b>305.5E2 CR</b>	<b>307E2</b>	<b>308E2 CR SB</b>	<b>308E2 VAB</b>
<b>Undercarriage:</b>				
Standard	●	●	●	●
<b>Booms:</b>				
Swing	●	●	●	●
<b>Sticks:</b>		<b>mm</b> <b>ft</b>	<b>mm</b> <b>ft</b>	<b>mm</b> <b>ft</b>
Medium	●	1665      5'6"	1665      5'6"	1665      5'6"
Long	●	—	2210      7'3"	2210      7'3"
<b>Teeth:</b>				
Long	●	●	●	●
Light Duty Long	●	●	●	●
Short	●	●	●	●
Wide	●	●	●	●
Penetration	●	●	●	●
Sharp — Corner	●	●	●	●
Sharp — Center	●	●	●	●
Sharp — Twin	●	●	●	●
Heavy Duty Long	●	●	●	●
Heavy Duty Abrasion	●	●	●	●
Abrasion	●	●	●	●
<b>Side Cutters:</b>				
One-Piece Blade	●	●	●	●
<b>Track Shoes:</b>	Triple Grouser 400 mm (16") Rubber Belt 400 mm (16")	Rubber Belt 450 mm (18") Triple Grouser with Pad 450 mm (18")	Rubber Belt 450 mm (18") Triple Grouser 450 mm (18") Triple Grouser with Pad 450 mm (18") Triple Grouser 600 mm (24")	Rubber Belt 450 mm (18") Triple Grouser 450 mm (18") Triple Grouser with Pad 450 mm (18") Triple Grouser 600 mm (24")

**NOTE:** Number of buckets includes General Purpose, Trenching and Rock. Other types of buckets have not been included.  
All attachments may not be available in all sales areas.

# Hydraulic Excavators

## Summary of Major Attachments

- 311F L RR ● 312D2 ● 312D2 GC ● 312D2 L
- 313D2 ● 312E ● 312E L ● 313D2 LGP

EQUIPMENT FOR ...	311F L RR		312D2 312D2 GC		312E 312E L		313D2 LGP	
			312D2 L 313D2					
<b>Undercarriage:</b>								
Standard	—		●		●		●	
Long (L)	●		●		●		—	
<b>Booms:</b>								
One-Piece Reach	●		●		●		—	
One-Piece Reach— HD	—		●		—		●	
<b>Sticks:</b>	<b>mm</b>	<b>ft</b>	<b>mm</b>	<b>ft</b>	<b>mm</b>	<b>ft</b>	<b>mm</b>	<b>ft</b>
Short	—		—		2100	6'11"	—	
Medium	2250	7'5"	2500	8'2"	2500	8'2"	—	
Medium— HD	—		2500 8'2"		—		2500	8'2"
Intermediate	—		—		2800	9'2"	—	
Long	2800	9'2"	3000	9'10"	3000	9'10"	3000	9'10"
<b>Booms:</b>								
Two-Piece VA	—		—		●		—	
<b>Buckets (No. of)</b>	19		19		14		14	
<b>Teeth*:</b>								
Abrasion — HD	●		●		●		●	
Long (G.P.)	●		●		●		●	
Long — HD	●		●		●		●	
Short (Rock)	●		●		●		●	
Penetration	●		●		●		●	
Wide (Spade)	●		●		●		●	
Sharp — Center	●		●		●		●	
Sharp — Corner	●		●		—		●	
<b>Side Cutters:</b>								
One-Piece Blade	●		●		●		●	
<b>Track Shoes:</b>	Triple Grouser 500, 600, 700, 770 mm (20", 24", 28", 30")		Triple Grouser 500, 600, 700, 770 mm (20", 24", 28", 30")		Triple Grouser 500, 600, 700, 770, mm (20", 24", 28", 30")		Single Grouser 960 mm (38") Triple Grouser 500 mm (20")	
<b>Blade</b>	●		●		●		—	

\*J Series Tooth System for 311F L RR, 312D2, 312D2 GC, 312D2 L and 313D2 models.

**NOTE:** Number of buckets includes General Purpose, Trenching and Rock. Other types of buckets have not been included.  
All attachments may not be available in all sales areas.

EQUIPMENT FOR ...	314E CR 314E LCR		316E L		318D2 L		318E L	
<b>Undercarriage:</b>								
Standard	●		—		—		—	
Long (L)	●		●		●		●	
<b>Booms:</b>								
One-Piece Reach	●		●		●		●	
Parallel Offset	●		—		—		—	
<b>Sticks:</b>	<b>mm</b>	<b>ft</b>	<b>mm</b>	<b>ft</b>	<b>mm</b>	<b>ft</b>	<b>mm</b>	<b>ft</b>
Short	2100	6'11"	2250	7'4"	—		2250	7'5"
●	2130	6'11"	2600	8'6"	2600	8'6"	2600	8'6"
Medium	2500	8'2"	2900	9'6"	2900	9'6"	2900	9'2"
Intermediate	2800	9'2"	—		—		—	
Long	3000	9'10"	3100	10'2"	—		3100	10'2"
<b>Booms:</b>								
One-Piece Mass	●		●		●		●	
Two-Piece VA	●		●		—		●	
<b>Buckets (No. of)</b>	14		18		18		18	
<b>Teeth*:</b>								
Abrasion — HD	●		—		—		—	
Long (G.P.)	●		—		—		—	
Long — HD	●		—		—		—	
Short (Rock)	●		—		—		—	
General Duty	—		●		●		●	
Penetration	●		●		●		●	
Penetration Plus	—		●		●		●	
Wide	—		●		●		●	
Wide (Spade)	●		—		—		—	
Extra Duty	—		●		●		●	
Spike	—		●		●		●	
Double Spike	—		●		●		●	
Sharp — Center	●		—		—		—	
Sharp — Corner	●		—		—		—	
<b>Side Cutters:</b>								
One-Piece Blade	●		●		●		●	
<b>Track Shoes:</b>	Triple Grouser 500, 600, 700 mm (20", 24", 28")		Triple Grouser 500, 600, 700 mm (20", 24", 28")		Triple Grouser 500, 600, 700 mm (20", 24", 28")		Triple Grouser 500, 600, 700, 790 mm (20", 24", 28", 31")	
<b>Blade</b>	●		—		—		—	

\*K Series Tooth System for 316E L, 318D2 L and 318E L models.

**NOTE:** Number of buckets includes General Purpose, Trenching and Rock. Other types of buckets have not been included.  
All attachments may not be available in all sales areas.

# Hydraulic Excavators

## Summary of Major Attachments

- 320D2 ● 320D2 GC ● 320D2 L ● 320E ● 320E L
- 320E RR ● 320E LRR ● 320F L

EQUIPMENT FOR ...	320D2		320E		320E RR		320F L	
	320D2 GC	320D2 L	320E L	320E L	320E LRR	320E LRR	320F L	320F L
<b>Undercarriage:</b>								
Standard	●		●		●		●	
Long (L)	●		●		●		●	
<b>Booms:</b>								
One-Piece Reach	●		●		●		●	
One-Piece Reach — HD	●		●		●		—	
Two Pieces — VA	—		●		—		●	
<b>Sticks:</b>	<b>mm</b>	<b>ft</b>	<b>mm</b>	<b>ft</b>	<b>mm</b>	<b>ft</b>	<b>mm</b>	<b>ft</b>
Short	2900	9'6"	2500	8'2"	—		—	
Short — HD	2500	8'2"	2500	8'2"	—		—	
● — HD	2900	9'6"	—		—		—	
Medium	—		2920	9'6"	2920	9'6"	2920	9'6"
Medium — HD	—		2920	9'6"	2920	9'6"	—	
Super Long Reach (SLR)	6280	20'7"	—		—		—	
<b>Booms:</b>								
One-Piece Mass	●		—		—		—	
<b>Sticks:</b>	<b>mm</b>	<b>ft</b>						
Short	2400	7'11"	—		—		—	
<b>Bucket Family</b>	B1		B1		B1		B1	
<b>Buckets (No. of)</b>	32		—		—		—	
<b>Teeth:</b>								
Abrasion — HD	●		—		—		—	
Long (G.P.)	●		—		—		—	
Long — HD	●		—		—		—	
Short (Rock)	●		—		—		—	
Penetration	●		—		—		—	
Wide (Spade)	●		—		—		—	
Sharp — Center	●		—		—		—	
Sharp — Corner	●		—		—		—	
<b>Side Cutters:</b>								
One-Piece Blade	●		—		—		—	
<b>Track Shoes:</b>								
	Triple Grouser 600, 700, 790 mm (24", 28", 31") Double Grouser 600 mm (24")		Triple Grouser 600, 700, 790, 900 mm (24", 28", 31", 35")		Triple Grouser 600, 700, 790 mm (24", 28", 31")		Triple Grouser 600, 700, 790 mm (24", 28", 31")	

**NOTE:** Number of buckets includes General Purpose, Trenching and Rock. Other types of buckets have not been included.  
All attachments may not be available in all sales areas.

EQUIPMENT FOR ...	323D2 L		323F L		323F LN	
<b>Undercarriage:</b>						
Standard	—		—		—	
Long (L)	●		●		●	
Long (LN)	—		—		●	
<b>Booms:</b>						
One-Piece Reach	●		●		—	
One-Piece Reach — HD	●		●		●	
One-Piece Reach — ES	—		—		—	
Two Pieces — VA	—		—		●	
<b>Sticks:</b>	<b>mm</b>	<b>ft</b>	<b>mm</b>	<b>ft</b>	<b>mm</b>	<b>ft</b>
Short	2900	9'6"	2900	9'6"	2500	8'2"
Short — HD	2500	8'2"	—		—	
● — HD	2900	9'6"	—		—	
Medium	—		2900	9'6"	2920	9'6"
Medium — HD	—		—		—	
Medium — ES	—		2900	9'6"	—	
Medium Thumb Ready — ES	—		2900	9'6"	—	
Long	—		3900	12'10"	—	
Super Long Reach (SLR)	—		6280	20'7"	—	
<b>Booms:</b>						
One-Piece Mass	●		—		—	
<b>Sticks:</b>	<b>mm</b>	<b>ft</b>				
Short	1900	6'2"	—		—	
●	2400	7'10"	—		—	
<b>Bucket Family</b>	B1, CB2		B1		B1	
<b>Buckets (No. of)</b>	18		—		—	
<b>Teeth:</b>						
Abrasion — HD	●		—		—	
Long (G.P.)	●		—		—	
Long — HD	●		—		—	
Short (Rock)	●		—		—	
Penetration	●		—		—	
Wide (Spade)	●		—		—	
Sharp — Center	●		—		—	
Sharp — Corner	●		—		—	
<b>Side Cutters:</b>						
One-Piece Blade	●		—		—	
<b>Track Shoes:</b>	Triple Grouser 600, 700, 790, 900 mm (24", 28", 31", 35") Double Grouser 600, 700 mm (24", 28")		Single Grouser 600 mm (24") Triple Grouser 790 mm (31")		Triple Grouser 500 mm (20")	

NOTE: Number of buckets includes General Purpose, Trenching and Rock. Other types of buckets have not been included.  
 All attachments may not be available in all sales areas.



<b>EQUIPMENT FOR ...</b>	<b>325F L</b>		<b>326D2 L</b>		<b>326F L 326F LN</b>	
<b>Undercarriage:</b>						
Standard		—		●		—
Long (L)		●		●		●
Long Narrow (LN)		—		—		●
<b>Booms:</b>						
One-Piece Reach		●		●		●
One-Piece Reach — HD		—		●		—
Two Pieces — VA		●		—		●
<b>Sticks:</b>	<b>mm</b>	<b>ft</b>	<b>mm</b>	<b>ft</b>	<b>mm</b>	<b>ft</b>
Short		—	2500	8'2"	2500	8'2"
Medium	2920	9'6"	2950	9'8"	2950	9'8"
Medium — HD		—	2950	9'8"		—
Long		—		—	3600	11'10"
Super Long Reach (SLR)		—	7850	25'9"	7850	25'9"
<b>Bucket Family</b>		B1		CB1		A, CB1
<b>Buckets (No. of)</b>		—		32		—
<b>Teeth:</b>						
Abrasion — HD		—		●		—
Long (G.P.)		—		●		—
Long — HD		—		●		—
Short (Rock)		—		●		—
Penetration		—		●		—
Wide (Spade)		—		●		—
Sharp — Center		—		●		—
Sharp — Corner		—		●		—
<b>Side Cutters:</b>						
One-Piece Blade		—		●		—
Side Bar Protector		—		●		—
<b>Track Shoes:</b>						
		Triple Grouser 600, 790 mm (24", 31")		Double Grouser 600 mm (24") Triple Grouser 600, 790 mm (24", 31")		Single Grouser 600 mm (24") Triple Grouser 600, 790, 900 mm (24", 31", 35")

**NOTE:** Number of buckets includes General Purpose, Trenching and Rock. Other types of buckets have not been included.  
All attachments may not be available in all sales areas.

<b>EQUIPMENT FOR ...</b>	<b>330D2 L</b>		<b>330F L 330F LN</b>		<b>335F L</b>	
<b>Undercarriage:</b>						
Standard	●		—		—	
Long (L)	●		●		●	
Long Narrow (LN)	—		●		—	
<b>Booms:</b>						
One-Piece Reach	●		●		●	
One-Piece Reach — HD	—		●		—	
<b>Sticks:</b>	<b>mm</b>	<b>ft</b>	<b>mm</b>	<b>ft</b>	<b>mm</b>	<b>ft</b>
Short	2650	8'8"	2650	8'8"	—	—
Short — HD	—		—		2650	8'8"
Medium	3200	10'6"	3200	10'6"	—	—
Medium — HD	—		—		3200	10'6"
Long	—		3750	12'4"	3750	12'4"
Super Long Reach (SLR)	7850	25'9"	7850	25'9"	—	—
<b>Booms:</b>						
One-Piece Mass	●		—		—	
<b>Sticks:</b>	<b>mm</b>	<b>ft</b>				
Short	2500	8'2"	—		—	
<b>Bucket Family</b>	CB1, CB2, DB		A, CB2		CB2	
<b>Buckets (No. of)</b>	32		—		—	
<b>Teeth:</b>						
Abrasion — HD	●		—		—	
Long (G.P.)	●		—		—	
Long — HD	●		—		—	
Short (Rock)	●		—		—	
Penetration	●		—		—	
Wide (Spade)	●		—		—	
Sharp — Center	●		—		—	
Sharp — Corner	●		—		—	
<b>Side Cutters:</b>						
One-Piece Blade	●		—		—	
<b>Track Shoes:</b>	Double Grouser 600 mm (24") Triple Grouser 600, 700, 800 mm (24", 28", 32")		Single Grouser 600 mm (24") Double Grouser 600 mm (24") Triple Grouser 600, 700, 800, 900 mm (24", 28", 32", 35")		Triple Grouser 600, 700, 850 mm (24", 28", 33")	

**NOTE:** Number of buckets includes General Purpose, Trenching and Rock. Other types of buckets have not been included.  
All attachments may not be available in all sales areas.

<b>EQUIPMENT FOR ...</b>	<b>336D2 336D2 L</b>		<b>349D2, 349D2 L 349F L, 352F</b>	
<b>Undercarriage:</b>				
Standard		●		●
Long (L) – VG		–		●
Long (L) – FIX		●		●
Extreme Service (ES)		–		–
<b>Booms:</b>				
One-Piece Reach		●		●
One-Piece Reach – HD		–		●
<b>Sticks:</b>	<b>mm</b>	<b>ft</b>	<b>mm</b>	<b>ft</b>
Short	2800	9'2"	2900	9'6"
●		–	3350	11'0"
Short – HD		–	2900	9'6"
● – HD		–	3350	11'0"
Medium	3200	10'6"		–
Long	3900	12'10"	3900	12'10"
Long – HD		–	3900	12'10"
Long Reach – HD		–	4300	14'1"
<b>Booms:</b>				
One-Piece Mass		●		–
One-Piece Mass – HD		–		●
<b>Sticks:</b>	<b>mm</b>	<b>ft</b>	<b>mm</b>	<b>ft</b>
Short	2150	7'1"	2500	8'2"
●	2550	8'5"	3000	9'10"
Short – HD		–	2500	8'2"
● – HD		–	3000	9'10"
<b>Bucket Family</b>	DB, TB1		TB, UB	
<b>Buckets (No. of)</b>	34		32	
<b>Teeth:</b>				
Abrasion – HD		●		●
Long (G.P.)		●		●
Long – HD		●		●
Short (Rock)		●		●
Penetration		●		●
Penetration Plus		–		●
Wide (Spade)		●		–
Sharp – Center		●		–
Sharp – Corner		●		–
<b>Side Cutters:</b>				
One-Piece Blade		●		CWTS
<b>Track Shoes:</b>	Double Grouser 600 mm (24") Triple Grouser 600, 700, 800 mm (24", 28", 32")		Double Grouser 600, 750 mm (24", 30") Triple Grouser 600, 750, 900 mm (24", 30", 35")	

**NOTE:** Number of buckets includes General Purpose, Trenching and Rock. Other types of buckets have not been included.  
All attachments may not be available in all sales areas.

<b>EQUIPMENT FOR ...</b>	<b>374F L</b>		<b>390F L</b>	
<b>Undercarriage:</b>				
Standard	—		●	
Long (L) — VG	●		●	
Extreme Service (ES)	●		—	
<b>Booms:</b>				
One-Piece Reach	●		●	
One-Piece — GP	—		●	
<b>Sticks:</b>	<b>mm</b>	<b>ft</b>	<b>mm</b>	<b>ft</b>
Short	2840	9'2"	2920	9'5"
●	3600	11'8"	3400	11'2"
●	4150	13'8"	3700	12'1"
●	4670	15'4"	4400	14'4"
Short — HD	—		5500	18'1"
<b>Booms:</b>				
One-Piece Mass	●		●	
<b>Sticks:</b>	<b>mm</b>	<b>ft</b>	<b>mm</b>	<b>ft</b>
Short	2570	8'5"	2920	9'5"
●	3000	9'8"	3400	11'2"
<b>Bucket Family</b>	VB, WB		HB, JB	
<b>Buckets (No. of)</b>	24		14	
<b>Teeth:</b>				
Long (G.P.)	●		●	
Long — HD	●		●	
Short (Rock)	●		●	
Penetration	●		●	
Penetration Plus	●		●	
<b>Track Shoes:</b>	Double Grouser 650, 750, 900 mm (26", 30", 35")		Double Grouser 650, 750, 900 mm (26", 30", 35")	

**NOTE:** Number of buckets includes General Purpose, Trenching and Rock. Other types of buckets have not been included.  
 All attachments may not be available in all sales areas.

<b>EQUIPMENT FOR ...</b>	<b>M314F</b>		<b>M316F</b>		<b>M318F</b>		<b>M320F</b>		<b>M322F</b>	
<b>Undercarriage:</b>										
Wheeled	●		●		●		●		●	
<b>Booms:</b>										
One-piece	●		●		●		●		●	
VA	●		●		●		●		●	
VA + Boom Offset	●		●		●		—		—	
<b>Sticks:</b>	<b>mm</b>	<b>ft</b>	<b>mm</b>	<b>ft</b>	<b>mm</b>	<b>ft</b>	<b>mm</b>	<b>ft</b>	<b>mm</b>	<b>ft</b>
Short	2000	6'7"	2100	6'11"	2100	6'11"	2200	7'3"	2200	7'3"
Medium	2300	7'7"	2400	7'10"	2400	7'10"	2500	8'2"	2500	8'2"
Long	2600	8'6"	2600	8'6"	2600	8'6"	2800	9'2"	2900	9'6"
Industrial Drop Nose	2900	9'6"	—		3100	10'2"	3300	10'10"	—	
<b>Buckets (No. of)</b>	21		27		27		28		23	
<b>Teeth:</b>										
Abrasion	●		●		●		●		●	
Long (G.P.)	●		●		●		●		●	
Short (Rock)	●		●		●		●		●	
Penetration	●		●		●		●		●	
Wide	●		●		●		●		●	
Sharp	●		●		●		●		●	
<b>Tires:</b>	10.00-20 16 PR 18R 19.5 XF 10.00-20 SR dual		10.00-20 16 PR 18R 19.5 XF 10.00-20 SR dual		10.00-20 16 PR 18R 19.5 XF 10.00-20 SR dual		10.00-20 16 PR 18R 19.5 XF 10.00-20 SR dual		11.00-20 16 PR 10.00-20 SR	

Work Tools	300.9D	301.4C, 301.7D, 301.7D CR	302.2D, 302.4D, 302.7D CR	303E CR, 303.5E CR, 303.5E2 CR	304E CR, 304E2 CR, 304.5E2 XTC	305E CR, 305E2 CR, 305.5E CR, 305.5E2 CR	307E2, 308E2 CR SB, 308E2 VAB	311D LRR, 312E L, 314D CR, 314D LCR	315D L, 316E L	318E	319D L, 319D LN	M314F, M316F	M318F, M320F, M322F	320E L, 320E LRR, 321D CR, 323D	324D, 324E	329D, 329E	336D, 336E	349D2, 349E, 349F	365C L	374D	385C	390D
Auger		X	X	X	X	X	X															
Clean Up Buckets								X	X	X		X	X	X	X	X	X					
Contractor's Grapple							X	X	X	X	X	X	X	X	X	X	X	X	X	X	X	X
Demolition and Sorting Grapples							X	X	X	X	X	X	X	X	X	X	X	X	X	X	X	X
Digging Buckets	X	X	X																			
Ditch Cleaning Bucket	X	X	X	X	X	X	X	X	X	X		X	X	X	X	X	X	X	X			
Extreme Duty Bucket																	X	X		X		X
General Duty Bucket								X	X	X		X	X	X	X	X	X	X	X		X	X
General Duty, High Capacity Bucket																		X		X		X
General Duty WideTip								X	X					X	X	X	X	X	X			
General Purpose Bucket																			X		X	
Heavy Duty Bucket				X	X	X	X			X	X	X	X	X	X	X	X	X	X	X	X	
Heavy Duty Capacity						X																
Heavy Duty Power Bucket														X	X	X	X					
Heavy Duty Rock							X	X	X													
Hydraulic Hammer	X	X	X	X	X	X	X	X	X	X	X	X	X	X	X	X	X	X	X	X	X	
Mud Bucket		X	X	X	X	X	X															
Multi-Processor										X	X	X	X	X	X	X	X	X	X	X	X	X
Pulverizers								X	X	X	X	X	X	X	X	X	X	X	X			
Quick Coupler		X	X	X	X	X	X	X	X	X	X	X	X	X	X	X	X	X	X	X	X	X
Rippers				X	X	X	X		X	X	X	X	X	X	X	X	X	X	X	X	X	X
Severe Duty Bucket								X	X	X				X	X	X	X	X	X		X	X
Shear				X	X	X	X	X	X	X	X	X	X	X	X	X	X	X	X	X	X	X
Thumb – Pro Series							X	X	X	X	X			X	X	X						
Thumb – Utility			X	X	X	X	X	X	X	X	X			X	X	X						
Thumb – Stiff Link							X	X	X	X	X	X	X	X	X	X	X	X	X			
Tilting Ditch Cleaning Bucket		X	X	X	X	X																
Trash Grapple								X	X	X	X	X	X	X	X	X	X	X	X			
Vibratory Plate Compactor			X	X	X	X	X	X	X	X	X	X	X	X	X	X	X	X				

NOTE: Other attachments available upon request. Contact your Cat dealer.

**CYCLE TIME ESTIMATING CHARTS**

The digging cycle of the excavator is composed of four segments:

1. Load Bucket
2. Swing Loaded
3. Dump Bucket
4. Swing Empty

Total excavator cycle time is dependent on machine size (small machines can cycle faster than large machines) and job conditions. With excellent job conditions the excavator can cycle fast. As job conditions become more severe (tougher digging, deeper trench, more obstacles, etc.), the excavator slows down accordingly. As the soil gets harder to dig, it takes longer to fill the bucket. As the trench gets deeper and the spoil pile larger, the bucket has to travel farther and the upper structure has to swing farther on each digging cycle.

Spoil pile or truck location also affects cycle time. If a truck is located on the floor of the excavation beside material being moved, 10 to 17 second cycles are practical. The other extreme would be a truck or spoil pile located above the excavator 180° from the excavation.

In sewer construction work the operator may not be able to work at full speed because he has to dig around existing utilities, load the bucket inside a trench shield, or avoid people working in the area.

**The Cycle Time Estimating Chart** outlines the range of total cycle time that can be expected as job conditions range from excellent to severe. Many variables affect how fast the excavator is able to work. The chart defines the range of cycle times frequently experienced with a machine and provides a guide to what is an “easy” or a “hard” job. The estimator can then evaluate the conditions of his job and use the Cycle Time Estimating Chart to select the appropriate working range. A practical method of further calibrating the Cycle Time Estimating Chart is to observe excavators working in the field and correlate measured cycle times to job conditions, operator ability, etc.

The following table breaks down what experience has shown to be typical Cat excavator cycle times with

- no obstruction in the right of way
- above average job conditions
- an operator of average ability and
- 60°-90° swing angle.

These times would decrease as job conditions or operator ability improved and would get slower as conditions become less favorable.

**CYCLE TIME -vs- JOB CONDITION DESCRIPTION**

**Fastest Possible**

**Fastest Practical**

**Typical Range**

**Slow**



**KEY**

- A — Excellent
- B — Above Average
- C — Average
- D — Below Average
- E — Severe

- Easy digging (unpacked earth, sand gravel, ditch cleaning, etc.). Digging to less than 40% of machine’s maximum depth capability. Swing angle less than 30°. Dump onto spoil pile or truck in excavation. No obstructions. Good operator.
- Medium digging (packed earth, tough dry clay, soil with less than 25% rock content). Depth to 50% of machine’s maximum capability. Swing angle to 60°. Large dump target. Few obstructions.
- Medium to hard digging (hard packed soil with up to 50% rock content). Depth to 70% of machine’s maximum capability. Swing angle to 90°. Loading trucks with truck spotted close to excavator.
- Hard digging (shot rock or tough soil with up to 75% rock content). Depth to 90% of machine’s maximum capability. Swing angle to 120°. Shored trench. Small dump target. Working over pipe crew.
- Toughest digging (sandstone, caliche, shale, certain limestones, hard frost). Over 90% of machine’s maximum depth capability. Swing over 120°. Loading bucket in man box. Dump into small target requiring maximum excavator reach. People and obstructions in the work area.

**Cycle Time Estimating Chart**

Model		308E2 CR SB	311D LRR	312D, 312D L	315D L	319D L, 319D LN	M314F, M315D2	M316F, M317D2, M318F	M320F, M320D2	M322F, M322D2
Bucket Size	L	220	450	520	520	800	610	750	900	1050
	yd <sup>3</sup>	0.30	0.59	0.68	0.68	1.05	0.80	0.98	1.18	1.37
Soil Type		← Packed Earth				→ Sand/Gravel →				
Digging Depth	m	1.8	1.5	1.8	3.0	3.0	3.0	3.0	3.0	3.0
	ft	6'0"	5'0"	6'0"	10'0"	10'0"	10'0"	10'0"	10'0"	10'0"
Load Bucket	min	0.08	0.07	0.07	0.07	0.09	0.05	0.06	0.06	0.08
Swing Loaded	min	0.03	0.06	0.06	0.08	0.09	0.05	0.05	0.06	0.06
Dump Bucket	min	0.03	0.03	0.03	0.03	0.03	0.03	0.03	0.03	0.04
Swing Empty	min	0.08	0.05	0.05	0.06	0.07	0.04	0.04	0.05	0.05
Total Cycle Time	min	0.22	0.21	0.21	0.24	0.28	0.17	0.18	0.20	0.23

**Cycle Time Estimating Chart**

Model		320D2	320D RR, 321D CR, 323D2	324D	328D LCR	329D	336D	349D2, 349E, 349F	365C L	385C
Bucket Size	L	800	800	1000	N/A	1100	1400	2400	1900	3760
	yd <sup>3</sup>	1.05	1.05	1.31		1.44	1.83	3.0	2.5	5.0
Soil Type		← Hard Clay				→				
Digging Depth	m	2.3	2.3	3.2	N/A	3.2	3.4	4.0	4.2	5.6
	ft	8	8	10		10	11	13	14	18
Load Bucket	min	0.09	0.09	0.09	N/A	0.09	0.09	0.13	0.10	0.19
Swing Loaded	min	0.06	0.06	0.06	N/A	0.06	0.07	0.07	0.09	0.06
Dump Bucket	min	0.03	0.03	0.04	N/A	0.04	0.04	0.02	0.04	0.03
Swing Empty	min	0.05	0.05	0.06	N/A	0.06	0.07	0.06	0.07	0.07
Total Cycle Time	min	0.23	0.23	0.25	N/A	0.25	0.27	0.28	0.30	0.35

N/A = Not Applicable



CYCLE TIME ESTIMATING CHART														
CYCLE TIME	MACHINE SIZE CLASS													CYCLE TIME
	307C 308D CR 308D CR SB	311D	M314F M315D2 312D	M316F M317D2 M318F 315D L	M320F M320D2 319D L 319D LN	M322F M322D2 320D 320D RR 321D CR 323D	324D	328D LCR	329D	336D	349D2 349E 349F	365C L	385C	
10 SEC.								N/A						0.17 min.
15								N/A						0.25 min.
20 SEC.								N/A						0.33 min.
25														0.42 min.
30 SEC.														0.50 min.
35														0.58 min.
40 SEC.														0.67 min.
45														0.75 min.
50 SEC.														0.83 min.
55														0.92 min.
60 SEC.														1.0 min.

N/A = Not Applicable

Cat 300 Series Mass Excavation booms and buckets coupled with the proper stick will help you move material faster and more efficiently in production excavation and loading applications. With the largest bucket, shortest stick and long undercarriage your excavator can often do the work of a larger machine. A longer stick and standard undercarriage make it ideal for loading on-highway trucks and general construction jobs.

## MAXIMIZING PRODUCTION WITH A MASS EXCAVATOR

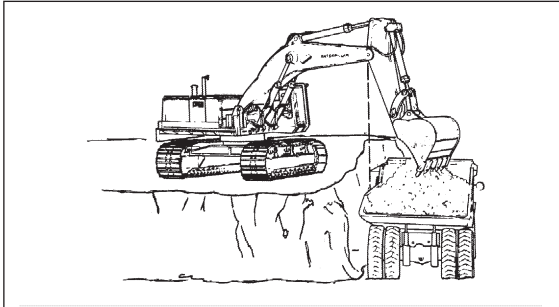

**Ideal Bench Height and Truck Distance** — For stable or consolidated materials, bench height should be about equal to stick length. For unstable materials it should be less. The most useful truck position is when the inside truck body rail is below the boomstick hinge pin.

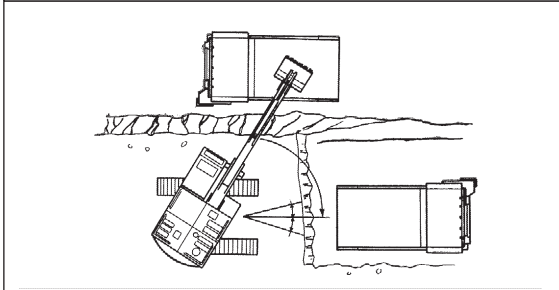

**Optimum Work Zone and Swing Angle** — For maximum production, the work zone should be limited to 15° either side of machine center or about equal to undercarriage width. Trucks should be positioned as close as possible to machine centerline. Two alternatives shown here.

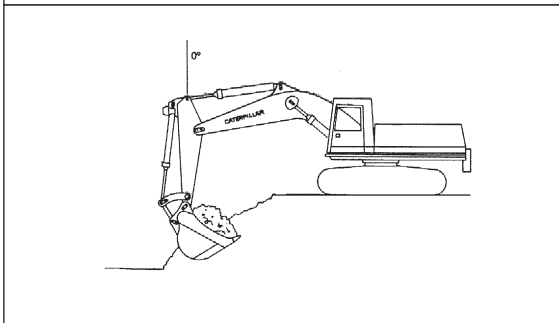

**Best Distance from the Edge** — The machine should be positioned so that the stick is vertical when the bucket reaches full load. If the unit is farther back, breakout force is reduced. If it is closer to the edge, undercutting may occur and time is wasted bringing the stick back out. Also, the operator should begin boom-up when the bucket is 75% of the way through the curl cycle. This should be as the stick nears the vertical position.

This example reflects the ideal situation. Not all points are usable on each job, but incorporation of as many of these points as possible will positively affect production.

**SELECTING A MASS EXCAVATOR**

Selecting a mass excavator model for optimum production requires matching the machine and bucket to the customer’s production requirements, material, and haulers. The following 6-Step selection process will help you to consider the key factors which will impact machine selection. Failure to consider these key elements in the selection process may result in choosing a machine that is too small to efficiently handle the desired bucket size or to meet the production requirement. Selecting a mass excavator which is too large may lead to excessive loader wait time, creating excessive “load shocks” into the hauler, and/or overloading the hauler capacity.

**Step 1**

*Determine the material type and bucket fill factor*

Refer to the bucket fill factors table.

Example:

Average Blasted Rock = 75 to 90%

**Step 2**

*Estimate the Cycle Time*

Refer to the cycle time estimating chart.

Example:

$\frac{365\text{B in Hard Rock Digging}}{\text{Shot Rock}} = .43 \text{ to } .52 \text{ minute}$

**Step 3**

*Calculate the Effective Cycles per Hour*

Divide the 60 minute hour by cycle time and adjust for availability and efficiencies.

Example:

<i>Cycle Time</i>	0.48 minute
$\frac{60 \text{ minute hour}}{\text{Cycle Time}}$	$\frac{60}{0.48} = 125$
<i>Operator Skill/Efficiency</i>	0.9 (90%)
<i>Machine Availability</i>	0.95 (95%)
<i>Gen Operational Efficiency</i>	0.83 (50 min/hr)
<i>Effective Cycles per Hour</i>	$125 \times .9 \times .95 \times .83 = 89$

**Step 4**

*Calculate the Required Bucket Capacity*

Divide hourly production requirement by effective cycles per hour, adjust for material density and fill factor.

Example (Metric):

<i>Hourly Production Required</i>	500 Tons/hour
<i>Effective cycles/hour</i>	89

$$\frac{\text{Hourly Production Required}}{\text{Effective cycles/hour}} = \frac{\text{Required Payload}}{\text{Material Density/Loose}} = \frac{500}{89} = 5.6$$

<i>Material Density/Loose</i>	1.6 Ton/m <sup>3</sup>
-------------------------------	------------------------

$$\frac{\text{Required Payload}}{\text{Material Density/Loose}} = \frac{\text{Bucket Payload}}{\text{Volume}} = \frac{5.6}{1.6} = 3.5 \text{ m}^3$$

<i>Fill Factor</i>	0.85 (85%)
--------------------	------------

$$\frac{\text{Bucket Payload}}{\text{Fill Factor}} = \frac{\text{Nominal Bucket Size}}{\text{Volume}} = \frac{3.5}{.85} = 4.1 \text{ m}^3$$

Example (English):

<i>Hourly Production Required</i>	550 tons/hour
<i>Effective cycles/hour</i>	89

$$\frac{\text{Hourly Production Required}}{\text{Effective cycles/hour}} = \frac{\text{Required Payload}}{\text{Material Density/Loose}} = \frac{550 \times 2000}{89} = 12,360 \text{ lb}$$

<i>Material Density/Loose</i>	2700 lb/yd <sup>3</sup>
-------------------------------	-------------------------

$$\frac{\text{Required Payload}}{\text{Material Density/Loose}} = \frac{\text{Bucket Payload}}{\text{Volume}} = \frac{12,360}{2700} = 4.6 \text{ yd}^3$$

<i>Fill Factor</i>	0.85 (85%)
--------------------	------------

$$\frac{\text{Bucket Payload}}{\text{Fill Factor}} = \frac{\text{Nominal Bucket Size}}{\text{Volume}} = \frac{4.6}{.85} = 5.4 \text{ yd}^3$$

**Step 5**

*Select Mass Excavator for required bucket size*

Refer to Performance Handbook to compare machine models and bucket ranges. Confirm bucket type, size, and maximum material density in Specalog for desired model.

Example:

Required bucket capacity approximately  
 4.1 m<sup>3</sup> (5.4 yd<sup>3</sup>)

345B L Series II ME bucket capacity  
 to 3.5 m<sup>3</sup> (4.6 yd<sup>3</sup>)

365B L Series II ME bucket capacity  
 to 5.3 m<sup>3</sup> (6.9 yd<sup>3</sup>)

385B L ME bucket capacity to 5.6 m<sup>3</sup> (7.3 yd<sup>3</sup>)

Best Choice 365B Series II with 4.0 m<sup>3</sup> (5.2 yd<sup>3</sup>)  
 Rock Bucket rated to 1.8 Ton/m<sup>3</sup> (3000 lb/yd<sup>3</sup>)  
 material density in Specalog

*Important: Re-calculate Steps 2 - 5 based on cycle times  
 of model selected.*

**Step 6**

*Select Haulers*

General rule for matching trucks is based on number of cycles to fill the truck.

ME: 4 to 6 passes

Front Shovels: 3 to 5 passes

Example (Metric):

*Bucket Selected* 4 m<sup>3</sup>  
*Volume in 5 passes* 5 × 4 × .85 = 17 m<sup>3</sup>  
*Payload* 17 × 1.6 = 27.2 Tons  
*Consider weight of Liners* 27.2 + 2 = 29.2 Tons

*Suitable Truck Match Options:*

735 with capacity 19.2 m<sup>3</sup>/31.8 t  
 769D with capacity 24.2 m<sup>3</sup>/37.9 t

Example (English):

*Bucket Selected* 5.2 yd<sup>3</sup>  
*Volume in 5 passes* 5 × 5.2 × .85 = 22.1 yd<sup>3</sup>  
*Payload* 22.1 × 2700 = 59,670 lb  
*Consider weight of Liners* 59,670 + 4400 lb = 64,070 lb

*Suitable Truck Match Options:*

735 with capacity 25.1 yd<sup>3</sup>/70,000 lb  
 769D with capacity 31.7 yd<sup>3</sup>/83,570 lb

**EARTHMOVING PRODUCTION**

As with any other piece of material handling equipment, excavator earthmoving production is dependent on average bucket payload, average cycle time and job efficiency. If an estimator can accurately predict excavator cycle time and bucket payload, a machine’s earthmoving production can be derived from the following formula.

$$m^3 (yd^3)/60 \text{ min hr} = \text{Cycles}/60 \text{ min hr} \times \text{Avg. Bucket Payload in } m^3 (yd^3)$$

$$\frac{m^3 (yd^3)/60 \text{ min hr}}{60 \text{ min/hr}} \times \text{Avg. Bucket Payload in } m^3 (yd^3)$$

$$\text{Avg. Bucket Payload} = \text{Heaped Bucket Capacity} \times \text{Bucket Fill Factor}$$

$$\text{Actual } m^3 (yd^3)/\text{hr} = m^3 (yd^3)/60 \text{ min hr} \times \text{Job Efficiency Factor}$$

The Production Estimating Tables (next page) will provide theoretical earthmoving production in cubic meters (yards) per hour if bucket size and cycle time can be estimated. The use of an average cycle time allows adjusting the estimated production for specific job sites and applications. For instance, estimating truck loading applications should include truck exchange times which extends the average cycle time and reduces production potential. The values in the table are based on a 60 minute work hour or 100% efficiency (a condition that is never achieved in reality). The estimator should apply a job efficiency factor to the figures in the table based on his judgment or knowledge of actual job conditions.

Areas outlined on the Production Estimating Table define the work ranges of excavators in the size classes of Cat 307 through 5230 ME Excavators. The upper limit on each area corresponds to the “fastest practical” cycle time for the machines. The width of each area corresponds to the range of bucket payload sizes the machine can handle. An unshaded box has been provided in each machine area to provide a guide indicating that the upper limit of earthmoving production is being approached. When working beyond the values in the white area, the estimator should be certain that excellent job conditions will be encountered (easy digging, shallow trench, good operator, etc.).

The Production Estimating Table can also serve as a guide when selecting the proper size machine to do a job, as is shown in the following example.

Example problem (Metric)

Contractor has a job to move 15 300 Bm<sup>3</sup> (19 100 Lm<sup>3</sup> considering 25% swell factor) of wet sandy loam material in rear dump on-highway trucks which will be loaded by an excavator. Average face depth will be 2.4 m with 60-90 degree average swing angle. Ten days are available to do the work. Contractor plans to work 10 hrs/day and estimates a 50 min. work hour (83% job efficiency). He has two excavators that could be made available to do the work — a 320 with 1.0 m<sup>3</sup> bucket or a 336 with 1.9 m<sup>3</sup> bucket. Experience has shown that either machine can get its rated capacity in the sandy loam soil. Could this job be done with either machine or will the 336 have to be used?

*Solution:* The excavator must produce 1900 Lm<sup>3</sup>/ Day (19 100 Lm<sup>3</sup> ÷ 10 Days) which means the required average hourly rate will be 190 Lm<sup>3</sup>/60 Min. Hr. (1900 Lm<sup>3</sup>/ Day ÷ 10 hrs/day). Further considering the 83% job efficiency, the excavator’s capability will have to be 230 Lm<sup>3</sup>/ 50 min hr.

The production estimating table shows that the 320 with a 1.0 m<sup>3</sup> bucket would have to achieve a 17.1 sec. average cycle time to produce the required 190 Lm<sup>3</sup>/60 min. hr. With job efficiency applied a 15.0 second average cycle time is required to produce the 230 Lm<sup>3</sup>/50 min. hr. The 336 with a 1.9 m<sup>3</sup> bucket could obtain the same 60 min. hr. production level with a 35 second average cycle, or 30 second cycles to meet the 50 min. hr. production requirement. The cycle times estimating chart shows that the 320 would be working near its maximum capability to meet the production requirement, whereas, the 336 could handle the job easily. This information can then be weighed against what else is known about the job (reach requirements, job conditions, operator ability, etc.) to decide whether or not the larger machine is needed.

Example problem (English)

Substitute these English values in the preceding problem:  
Job — 20,000 BCY (25,000 LCY considering 25% swell).  
Average face depth — 8-12 ft  
320 L with 1.25 yd<sup>3</sup> bucket or 336 with 2.5 yd<sup>3</sup> bucket.

*Solution:* The excavator must produce 2500 LCY/ Day, which means the required average hourly rate will be 250 LCY/60 min hr. Further considering the 83% job efficiency the excavator's capability will have to be 300 LCY/50 min hr.

The same concluding comments regarding the Production Estimating Table apply here as in the Metric example.

### Cubic Meters per 60 Minute Hour\*

ESTIMATED CYCLE TIMES		ESTIMATED BUCKET PAYLOAD** – LOOSE CUBIC METERS																			ESTIMATED CYCLE TIMES	
Cycle Time		0.2	0.3	0.5	0.7	0.9	1.1	1.3	1.5	1.7	1.9	2.1	2.3	2.5	2.7	2.9	3.1	3.3	3.5	4.0	Cycles Per Min.	Cycles Per Hr.
Seconds	Min.																					
10.0	0.17																				6.0	360
11.0	0.18																				5.5	330
12.0	0.20	60	90	150	210	270															5.0	300
13.3	0.22	54	81	135	189	243	297	351	405	459	513	567	621	675	729	783	837	891	945	1080	4.5	270
15.0	0.25	48	72	120	168	216	264	312	360	408	456	504	552	600	648	696	744	792	840	960	4.0	240
17.1	0.29	42	63	105	147	189	231	273	315	357	399	441	483	525	567	609	651	693	735	840	3.5	210
20.0	0.33	36	54	90	126	162	198	234	270	306	342	378	414	450	486	522	558	544	630	720	3.0	180
24.0	0.40	30	45	75	105	135	165	195	225	255	285	315	345	375	405	435	465	495	525	600	2.5	150
30.0	0.50	24	36	60	84	108	132	156	180	204	228	252	276	300	324	348	372	396	420	480	2.0	120
35.0	0.58	20	31	51	71	92	112	133	153	173	194	214	235	255	275	296	316	337	357	408	1.7	102
40.0	0.67					81	99	177	135	153	171	189	207	225	243	261	279	297	315	360	1.5	90
45.0	0.75									133	148	164	179	195	211	226	242	257	273	312	1.3	78
50.0	0.83																				1.2	72

### Cubic Yards per 60 Minute Hour\*

ESTIMATED CYCLE TIMES		ESTIMATED BUCKET PAYLOAD** – LOOSE CUBIC YARDS																			ESTIMATED CYCLE TIMES	
Cycle Time		0.25	0.50	0.75	1.00	1.25	1.50	1.75	2.00	2.25	2.50	2.75	3.00	3.25	3.50	3.75	4.00	4.50	5.00	5.25	Cycles Per Min.	Cycles Per Hr.
Seconds	Min.																					
10.0	0.17																				6.0	360
11.0	0.18																				5.5	330
12.0	0.20	75	150	225	300	375															5.0	300
13.3	0.22	67	135	202	270	337	404	472	540	607	675	742	810	877	945	1012	1080	1215	1350	1417	4.5	270
15.0	0.25	60	120	180	240	300	360	420	480	540	600	660	720	780	840	900	960	1080	1200	1260	4.0	240
17.1	0.29	52	105	157	210	262	315	367	420	472	525	577	630	682	735	787	840	945	1050	1102	3.5	210
20.0	0.33	45	90	135	180	225	270	315	360	405	450	495	540	585	630	675	720	810	900	945	3.0	180
24.0	0.40	37	75	112	150	187	225	262	300	337	375	412	450	487	525	562	600	675	750	787	2.5	150
30.0	0.50	30	60	90	120	150	180	210	240	270	300	330	360	390	420	450	480	510	600	630	2.0	120
35.0	0.58	36	51	77	102	128	154	180	205	231	256	282	308	333	360	385	410	462	513	535	1.7	102
40.0	0.67					112	135	157	180	202	225	247	270	292	315	337	360	405	450	472	1.5	90
45.0	0.75									180	200	220	240	260	280	300	320	360	400	409	1.3	78
50.0	0.83																				1.2	72

### Job Efficiency Estimator

Work Time/Hour	Efficiency
60 Min	100%
55	91%
50	83%
45	75%
40	67%

\*Actual hourly production = (60 min. hr. production) × (Job Efficiency Factor)

\*\*Estimated Bucket Payload = (Amount of Material in the Bucket) × (Heaped Bucket Capacity) × (Bucket Fill Factor)

Unshaded area indicates average production.

**Cubic Meters/Yards per 60 Minute Hour\***

ESTIMATED CYCLE TIMES		ESTIMATED BUCKET PAYLOAD** — LOOSE CUBIC METERS/YARDS											ESTIMATED CYCLE TIMES	
Cycle Time		5.0	6.0	7.0	8.0	9.0	10.0	11.0	12.0	13.0	14.0	15.0	Cycles Per Min.	Cycles Per Hr.
Seconds	Min.													
15.0	0.25	1200	1440	1680	1920	2160	2400	2640	2880	3120	3360	3600	4.0	240
17.1	0.29	1050	1260	1470	1680	1890	2100	2310	2520	2730	2940	3150	3.5	210
20.0	0.33	900	1080	1260	1440	1620	1800	1980	2160	2340	2520	2700	3.0	180
24.0	0.40	750	900	1050	1200	1350	1500	1650	1800	1950	2100	2250	2.5	150
30.0	0.50	600	720	840	960	1080	1200	1320	1440	1560	1680	1800	2.0	120
35.0	0.58	510	612	714	816	918	1020	1122	1224	1326	1428	1530	1.7	102
40.0	0.67	450	540	630	720	810	900	990	1080	1170	1260	1350	1.5	90
45.0	0.75	390	468	546	624	702	780	858	936	1014	1092	1170	1.3	78
50.0	0.83	360	432	504	576	648	720	792	864	936	1008	1080	1.2	72
55.0	0.92	330	396	462	528	594	660	726	792	858	924	990	1.1	66
60.0	1.00	300	360	420	480	540	600	660	720	780	840	900	1.0	60

7

**Cubic Meters/Yards per 60 Minute Hour\***

ESTIMATED CYCLE TIMES		ESTIMATED BUCKET PAYLOAD** — LOOSE CUBIC METERS/YARDS										ESTIMATED CYCLE TIMES	
Cycle Time		16.0	17.0	18.0	19.0	20.0	21.0	22.0	23.0	24.0	25.0	Cycles Per Min.	Cycles Per Hr.
Seconds	Min.												
15.0	0.25	3840	4080	4320	4560	4800	5040	5280	5520	5760	6000	4.0	240
17.1	0.29	3360	3570	3780	3990	4200	4410	4620	4830	5040	5250	3.5	210
20.0	0.33	2880	3060	3240	3420	3600	3780	3960	4140	4320	4500	3.0	180
24.0	0.40	2400	2550	2700	2850	3000	3150	3300	3450	3600	3750	2.5	150
30.0	0.50	1920	2040	2160	2280	2400	2520	2640	2760	2880	3000	2.0	120
35.0	0.58	1632	1734	1836	1938	2040	2142	2244	2346	2448	2550	1.7	102
40.0	0.67	1440	1530	1620	1710	1800	1890	1980	2070	2160	2250	1.5	90
45.0	0.75	1248	1326	1404	1482	1560	1638	1716	1794	1872	1950	1.3	78
50.0	0.83	1152	1224	1296	1368	1440	1512	1584	1656	1728	1800	1.2	72
55.0	0.92	1056	1122	1188	1254	1320	1386	1452	1518	1584	1650	1.1	66
60.0	1.00	960	1020	1080	1140	1200	1260	1320	1380	1440	1500	1.0	60

**Job Efficiency Estimator**

Work Time/Hour	Efficiency
60 Min	100%
55	91%
50	83%
45	75%
40	67%

\*Actual hourly production = (60 min. hr. production) × (Job Efficiency Factor)

\*\*Estimated Bucket Payload = (Amount of Material in the Bucket) × (Bucket Fill Factor)

NOTE: For estimating truck loading production include approximately 0.7 minutes for truck exchange time.



**EXCAVATOR TRENCHING PRODUCTION**

When an excavator is used for trenching applications, a meaningful expression of work produced is the machine's trenching rate expressed in meters or lineal feet per hour or per day. Trenching rate depends on the earthmoving production of the excavator being used and the size of the trench being excavated. Earthmoving production converts to trenching production as follows:

$$\text{Lineal Meters of Trench per Hour} = \frac{\text{Cubic Meters Excavated per Hour}}{\text{Cubic Meters per Lineal Meter of Trench}}$$

$$\text{Lineal Meters of Trench per Day} = (\text{Lineal Meters per Hour}) \times (\text{Trenching Hours per Day})$$

$$\text{Lineal Feet of Trench per Hour} = \frac{\text{Yd}^3 \text{ Excavated Per Hour}}{\text{Yd}^3 \text{ Per Lineal Foot of Trench}}$$

$$\text{Lineal Feet of Trench Per Day} = (\text{Lineal Ft Per Hour}) \times (\text{Trenching Hours Per Day})$$

For machines that work in trenching applications where they dig all of the time, the *Trenching Conversion Chart* provides easy conversion from m<sup>3</sup> (yd<sup>3</sup>) per hour to m (lineal feet) per hour, if the excavating rate m<sup>3</sup>/hr (yd<sup>3</sup>/hr) and trench volume m<sup>3</sup>/m (yd<sup>3</sup>/ft) are known. The following examples demonstrate how the Trenching Conversion Chart can be used.

Example problem (Metric)

Contractor estimates that the 329 Excavator will produce 200 Lm<sup>3</sup>/hour. Trench survey shows that the trench contains 2.5 Lm<sup>3</sup>/meter. What trenching rate will the 329 produce?

*Solution:* Enter the horizontal axis of the Trenching Conversion Chart at 200 m<sup>3</sup>/Hour and move up to the 2.5 m<sup>3</sup>/m diagonal line. Then move left to the vertical axis of chart and read answer of 80 m/hr.



Example problem 2 (Metric)

Contractor knows he must produce 1000 meters of trench in every 10 hour work day. Survey shows that trench contains 1.5 Bm<sup>3</sup> per lineal meter and soil swell factor is estimated at 30%. How much earthmoving production will the excavator have to provide in order to get the job done on time assuming a 50 min work hour? What Cat excavator will provide needed production at 6 meter maximum depth in sandy loam soil?

*Solution:* Determine trenching requirement 1000 meters in 10 hrs = 100 m/h. Convert Bm<sup>3</sup> to Lm<sup>3</sup> (excavator handles Lm<sup>3</sup>) 1.5 Bm<sup>3</sup>/m × 1.30 = 2.0 Lm<sup>3</sup>/m. Enter vertical axis of trenching conversion chart at m/h and travel horizontally to diagonal line representing 2.0 m<sup>3</sup>/m. Next move down to horizontal axis and read answer to 200 Lm<sup>3</sup>/50 min hr. Convert 200 Lm<sup>3</sup>/ 50 min hr to Lm<sup>3</sup>/ 60 min hr = 200 = 241 Lm<sup>3</sup>/60 min hr.

Production estimating tables in this section show that 241 Lm<sup>3</sup>/60 min hr is within the capability of a 329 Excavator. Job should then be checked for reach and lifting requirements to make sure that the 329 could handle these aspects of the work.



Example problem (English)

Contractor estimates that a 329 Excavator will produce 250 LCY/Hour. Trench survey shows that the trench contains 2.5 LCY/Foot. What trenching rate will the 329 produce?

*Solution:* Enter the horizontal axis of the Trenching Conversion Chart at 250 yd<sup>3</sup>/hr. Then move to the vertical axis of chart and read answer of 100 ft/hr.

The Trenching Conversion Chart can also be used to determine the required excavating rate if the contractor can define his trenching production requirement and the trench volume per lineal foot.



Example problem 2 (English)

Contractor knows he must produce 1000 ft of trench in every 10 hr work day. Survey shows that trench contains 1.6 BCY per lineal ft and soil swell factor is estimated at 25%. How much earthmoving production will excavator have to provide in order to get the job done on time assuming 50 min work hour? What Cat model will provide needed production at 8 ft depth in sandy loam soil?

*Solution:* Determine trenching requirement —  
1000 ft in 10 Hrs. = 100 ft/hr  
Convert BCY to LCY — 1.6 BCY/ft × 1.25 =  
2.0 LCY/ft

Enter vertical axis of trenching conversion chart at 100 ft/hr and travel over to diagonal line representing 2.0 yd<sup>3</sup>/ft. Next move down to horizontal axis and read answer of 200 LCY/50 min hr.

Convert 200 LCY/50 min hr to LCY/60 min hr =  
 $\frac{200}{0.83} = 241 \text{ LCY/60 min hr}$

Production estimating tables in this section show that 241 LCY/60 min. hr. is within capability of a 329 Excavator. Job should then be checked for reach and lifting requirements to make sure that the 329 could handle these aspects of the work.



**TRENCHING CONVERSION CHART — CUBIC METERS (yd<sup>3</sup>) PER HOUR TO METER (ft) PER HOUR**

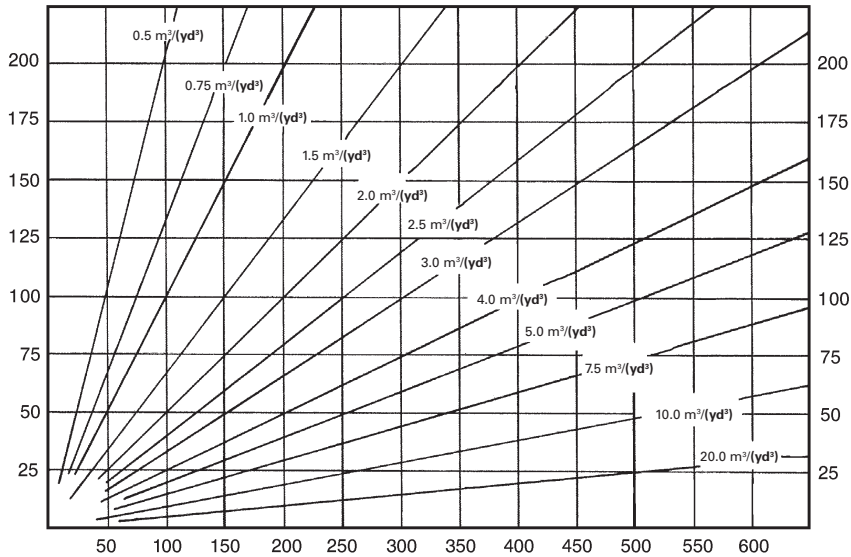

m (ft.) = m<sup>3</sup>/(yd<sup>3</sup>) Hr.  
Hr. = m<sup>3</sup>/(yd<sup>3</sup>) m (ft.)

Values in m<sup>3</sup>/m or yd<sup>3</sup>/ft

If excavating rate has been calculated in Bm<sup>3</sup>/h use Bm<sup>3</sup>/m for Trench Volume/m.  
" " " " " " " " Lm<sup>3</sup>/h use Lm<sup>3</sup>/m for Trench Volume/m.  
" " " " " " " " BCY/Hr use BCY/ft for Trench Volume/ft.  
" " " " " " " " LCY/Hr use LCY/ft for Trench Volume/ft.

**Estimating Bucket Size**

In addition to the trenching calculations on the previous pages, an alternative method of figuring trenching production is the nomograph. Shown on the following pages, this particular nomograph can be used for estimating bucket size when given trench dimensions and linear production rate. The nomograph is quicker and easier than the preceding example because it does not require as many calculations, yet the accuracy is about the same within the normal limits of input data.

Be careful when entering and reading data from the nomographs because some scales increase from bottom to top, while others are the reverse. Do not be overly concerned with the precision as affected by pencil line width or reading to the hundredth of a m<sup>3</sup> (yd<sup>3</sup>). Remember that bucket fill factor, material density and cycle time are at best close estimates.

Example problem:

A sewer contractor owns a 329 with 2 piece boom and short stick. He wants to bid a contract for a 3.1 m (10') deep trench which measures 1.8 m (6') at the top and 1.2 m (4') at the bottom. He must dig 9 m/hr (30 ft/hr) to finish on time. The material is sand and gravel with a load factor of 0.90 and 100% bucket fill factor. He works 54 minutes per hour, half the time digging and half setting pipe. Cycle time is estimated at 23 seconds which includes a 90° swing angle.

- 1) Enter trench depth 3.1 m (10') on scale A and average trench width 1.5 m (5') on scale B.
- 2) Connect A and B and extend to scale C for bank volume per m (ft).
- 3) Enter estimated load factor (0.90) on scale D.
- 4) Connect C & D and extend to scale E for loose volume per m (ft).

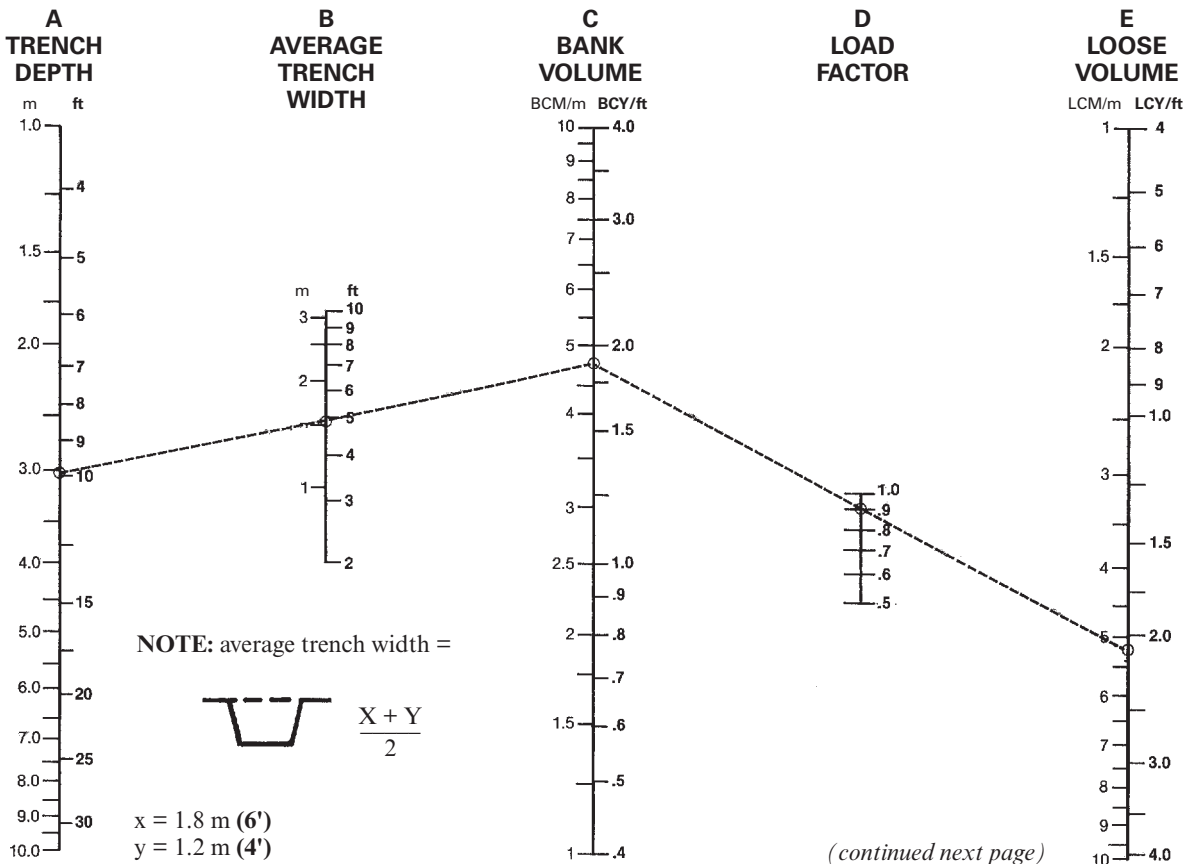

(get loose volume from scale E and enter on this page scale E)

- 5) Enter required linear production rate 9 m/h (30 t/hr) on scale G.
- 6) Connect E and G. Transfer hourly production rate from scale F to scale K (next page).

- 7) Estimate cycle time (23 sec) based on anticipated conditions and enter on scale H.
- 8) Estimate hourly digging time (27 min) and enter on scale I.
- 9) Connect H through I to scale J for cycles per hour.

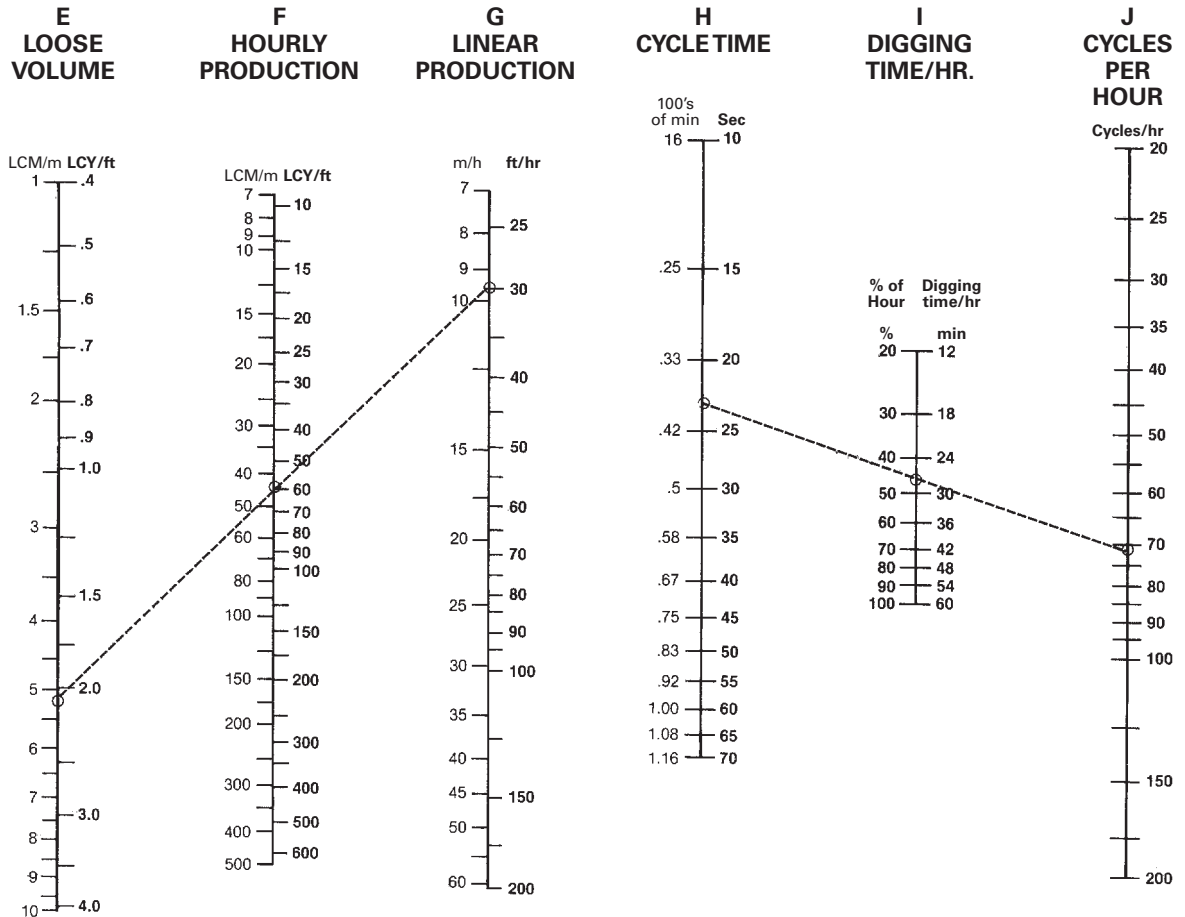

(get cycles per hour from scale J and enter on this page scale J)

- 10) Connect J through K to scale L for required volume per cycle.
- 11) Enter estimated bucket fill factor (100%) on scale M.
- 12) Connect L through M to scale N for required bucket size.

**NOTE:** Ensure bucket width does not exceed minimum trench width and also that weight of bucket and payload does not exceed machine working weight capacity (see lift capacity charts in this section).

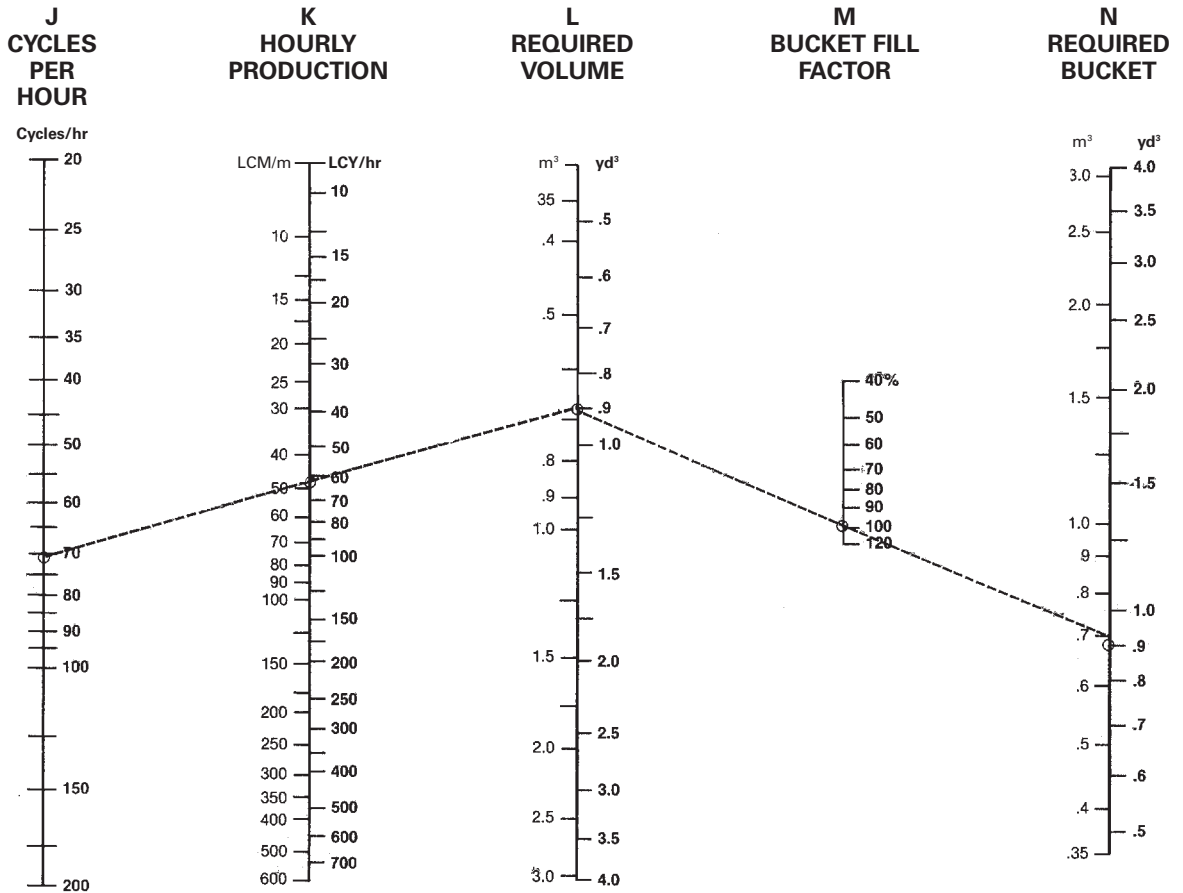

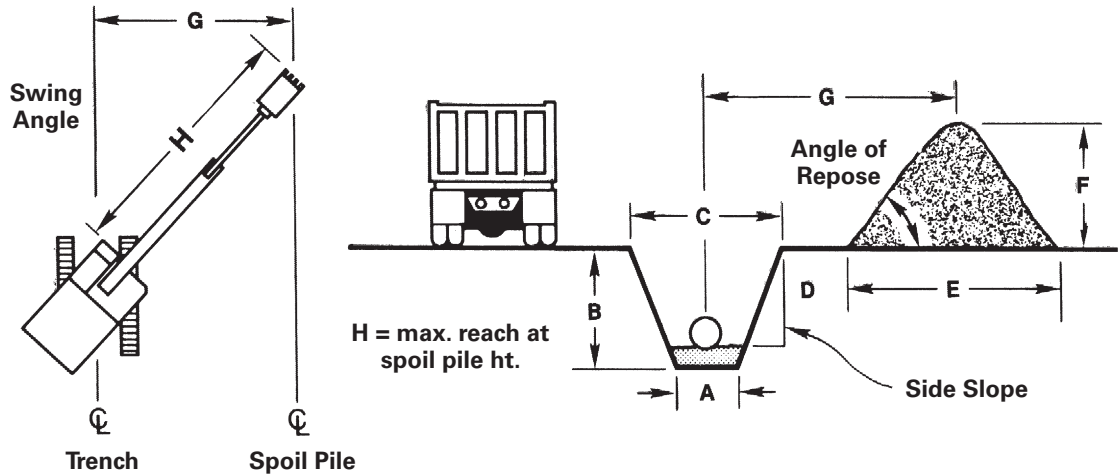

**Excavation Volumes Per Meter or Foot of Trench Length**

Metric version

Bank  $m^3/meter = (\text{Trench end area } m^2) \times (\text{one } m)$   
 Trench volume  $(Bm^3/m) = \frac{1}{2} (A + C) \times B$   
 Spoil pile volume  $(Lm^3/m) = (Bm^3/m) \times (1.00 + \% \text{ Swell})$

English version

Bank  $yd^3/foot = \frac{(\text{Trench end area } ft^2) \times (\text{one } ft)}{27}$   
 Trench volume  $(BCY/ft) = \frac{\frac{1}{2} (A + C) \times B}{27}$   
 Spoil pile volume  $(LCY/ft) = (BCY/ft) \times (1.00 + \% \text{ Swell})$

The following table provides a general guide to trench bottom width for various outside diameters of pipe.

Pipe Diameter		Trench Width		Pipe Diameter		Trench Width	
mm	ft/in	m	ft/in	mm	ft/in	m	ft/in
102	4"	0.49	1'7"	1524	5'0"	2.59	8'6"
152	6"	0.55	1'10"	1676	5'6"	2.80	9'2"
203	8"	0.61	2'0"	1829	6'0"	3.05	10'0"
254	10"	0.70	2'4"	1981	6'6"	3.26	10'8"
305	12"	0.76	2'6"	2134	7'0"	3.47	11'5"
381	15"	0.91	3'0"	2286	7'6"	3.69	12'1"
457	18"	1.03	3'5"	2438	8'0"	3.93	12'11"
533	1'9"	1.16	3'10"	2591	8'6"	4.15	13'7"
610	2'0"	1.25	4'1"	2743	9'0"	4.36	14'4"
686	2'3"	1.37	4'6"	2896	9'6"	4.54	14'11"
838	2'9"	1.58	5'2"	3048	10'0"	4.75	15'7"
914	3'0"	1.70	5'7"	3200	10'6"	4.99	16'5"
1067	3'6"	1.92	6'4"	3353	11'0"	5.21	17'1"
1219	4'0"	2.13	7'0"	3505	11'6"	5.43	17'10"
1372	4'6"	2.38	7'10"	3658	12'2"	5.64	18'6"

NOTE: Trench widths based on  $1.25 B_c + 1.0$  where  $B_c$  is the outside diameter of the pipe in feet.  
 Table courtesy of American Concrete Pipe Association

### Trenching Production with Pipesetting

On many sewer construction jobs the excavator does more than just dig the trench. Other tasks include handling the shoring system, placing bedding material, and lowering the pipe. The normal work procedure is to open a section of trench and then stop and make a pipe installation before going on to dig the next section of trench. At that point the key to trenching production is the total amount of time required to install each section of pipe. Pipe installation time can be broken down as follows:

Digging time + other time = Total pipe installation time

Total Pipe Installation Time	Pipe Installed Per Hour
60 min	1 Pipe/hr
30 min	2 Pipe/hr
15 min	4 Pipe/hr
10 min	6 Pipe/hr

Digging Time can be calculated once the trenching rate has been calculated using the methods described earlier in this section. Once Digging Time has been calculated, it can be added to an estimate of "Other Time" to determine Total Pipe Installation Time. "Other Time" can be estimated based on a contractor's judgment, experience, or actual measurement on a job. The following formula and table relate the trenching rate of the excavator to the time required to open a section of trench for pipe of various lengths.

$$\text{Digging Time (Min.)} = \frac{\text{Pipe Length (ft)}}{\text{Trenching Rate (ft/hr)}} \times 60 \text{ (Min/hr)}$$

Trenching Rate Ft. Per Hour	Time Required to Dig for Pipe of Various Lengths							
	8 ft Pipe		12 ft Pipe		16 ft Pipe		20 ft Pipe	
	Hours	Min.	Hours	Min.	Hours	Min.	Hours	Min.
20 ft/hr	0.400	24.00	0.600	36.00	0.800	48.00	1.000	60.00
40	0.200	12.00	0.300	18.00	0.400	24.00	0.500	30.00
60	0.130	8.00	0.200	12.00	0.260	16.00	0.333	20.00
80	0.100	6.00	0.150	9.00	0.200	12.00	0.250	15.00
100	0.080	4.80	0.120	7.20	0.160	9.60	0.200	12.00
120	0.060	4.00	0.100	6.00	0.120	7.20	0.167	10.00
140	0.057	3.43	0.086	5.14	0.114	6.86	0.143	8.57
160	0.050	3.00	0.075	4.50	0.100	6.00	0.125	7.50
180	0.044	2.66	0.067	4.00	0.089	5.33	0.111	6.67
200	0.040	2.40	0.060	3.60	0.080	4.80	0.100	6.00

This table can be used to show how an excavator that is capable of more trenching production will provide significant advantages even on jobs where the machine does not dig all of the time. Consider 12,000' job with

12' sections of pipe (1000 pipe to be installed). Excavator "A" can work at 60 ft/hr while Excavator "B" is capable of producing 120 ft/hr. Table shows that Excavator "B" will only take 0.10 hr to do the same work. This means that over the course of installing the 1000 pipe the more productive machine will save 0.10 hr/pipe or 100 hours of working time.

#### Example problem (English)

The following example shows how trenching production can be calculated on a job where the excavator is also required to set pipe. This example is based on the assumption that the excavator's earthmoving rate and the pipe installation time have already been estimated by the contractor.

**Problem:** Contractor estimates that the 350 Excavator will be able to produce 500 LCY/60 min. hr. Survey shows that an average cross section trench contains 3.2 BCY/ft and swell factor for sandy clay soil is estimated at 25%. How much trenching production can a contractor expect; assuming it takes 10.0 min. to install each 20 ft length of pipe after trench has been opened. Also assume 83% job efficiency — 50 min. work hour and 8 work hours out of a 9 hour shift. (0.5 hours for lunch and two 15 minute breaks.)

**Solution:**

Convert trench volume to LCY/ft:

$$1.25 (3.2 \text{ BCY/ft}) = 4.0 \text{ LCY/ft}$$

Convert Earthmoving rate to Trenching rate:

$$\frac{500 \text{ LCY/hr}}{4.0 \text{ LCY/ft}} = 125 \text{ ft/hr}$$

Calculate digging time for each pipe:

$$\frac{20 \text{ ft/pipe}}{125 \text{ ft/hr}} = 0.16 \text{ hr/pipe} = 9.6 \text{ min}$$

Calculate pipe installation time:

$$\text{Digging time} = 9.6 \text{ min}$$

$$\text{Other time} = 10.0 \text{ min}$$

$$\text{Pipe Installation time} = 19.6 \text{ min}$$

Calculate pipe installations/hour:

$$\frac{60 \text{ min/hr}}{19.6 \text{ min/pipe}} = 3.06 \text{ pipe/hr}$$

Calculate max. pipe installations/day:

$$8 \text{ hrs} (3.06 \text{ pipe/hr}) = 24.48 \text{ pipe/day}$$

Actual pipe/day:

$$0.83 (24.48 \text{ pipe/day}) = 20.3 - 20 \text{ pipe/day}$$

Actual feet/day:

$$(20 \text{ pipe/day}) \times (20 \text{ ft/pipe}) = 400 \text{ ft/day}$$

# HYDROMECHANICAL ATTACHMENTS

## CONTENTS

### HYDRAULIC HAMMERS

Features	
H25D	8-2
H35E s-H65E s	8-2
H75E s-H95E s	8-2
H110E s-H180E s	8-3
Tool Selection Guide	
Small Hammer Tools	8-4
Large Hammer Tools	8-5
Specifications	8-6
Selection	8-7
Cat® Carrier Matching Guide	8-8
Productivity	8-12

### MOBILE SCRAP AND DEMOLITION SHEARS

Applications	8-15
Guarding Recommendation	8-15
Shearing Capability Table	8-16
Specifications	8-17
Matching Guide	8-19

### MULTI-PROCESSORS

Features	8-21
Applications	8-21
Matching Guide	8-21
Jaw Types	8-21
Guarding Recommendation	8-22
Specifications	8-22
Cutting Capacity	8-30

### CONTRACTOR'S GRAPPLES

Features	8-31
Applications	8-31
Guarding Recommendation	8-31
Matching Guide	8-31
Specifications	8-32

### DEMOLITION AND SORTING GRAPPLES

Features	8-33
Matching Guide	8-33
Specifications	8-34

### ORANGE PEEL GRAPPLES

North America Version	
Features	8-39
Specifications	8-39
Matching Guide	8-41
Guarding Recommendation	8-41
Europe, Africa, Middle East Version	
Features	8-42
Selection Guide	8-42
Specifications	8-43
Matching Guide	8-47

### MULTI-FUNCTIONAL CONCRETE CRUSHERS

Features	8-48
Guarding Recommendation	8-48
Matching Guide	8-48
Specifications and Dimensions	8-49

### SECONDARY PULVERIZERS

Features	8-50
Guarding Recommendation	8-50
Matching Guide	8-50
Specifications and Dimensions	8-51

### BREAKERS

Specifications	8-52
----------------	------

### AUTO-CONNECT QUICK COUPLER

Machine Compatibility	8-54
-----------------------	------

### HYDRO MECHANICAL TOOLS FOR COMPACT EQUIPMENT

Please reference the Skid Steer Loaders/Multi Terrain Loaders/Compact Track Loaders section for the following hydro mechanical tools:

- Augers
- Backhoes
- Brooms
- Brushcutters
- Cold Planers
- Vibratory Compactors
- Mulchers
- Landscape Rakes
- Power Box Rakes
- Wheel Saws
- Snow Blowers
- Stump Grinders
- Landscape Tillers
- Trenchers



## HYDRAULIC HAMMERS

### H25D Hammer Features:

- **Streamlined Shape** fits into narrow places.
- **Simple Design** has only two moving parts for minimal maintenance.
- **High Blow Rate** translates to high productivity.
- **Lower Tool Bushing** can be replaced in minutes in the field.

### H35E s-H65E s Hammer Features:

- **Available** in both side plate and silenced versions.
- **Mounting Options** include integral pin-on and flat-top.
- **Gas-fired Operating Cycle** delivers consistent, reliable performance over time.
- **Auto Shut Off (ASO)** — Instantly stops the piston when breaking through material. Prevents blank firing, which is a top cause of hammer wear.
- **Plug and Perform** — No adjustment to pressures or flows is needed.
- **Dual Ports** optimize hose runs on HEX, BHL and SSL/MTL machines.
- **One-piece Body** reduces components, eliminates tie rods and nuts.
- **Single Bushing** design is slip fit and field-replaceable.
- **Tri-suspension System** guides the power cell and gives manageable, smooth performance.
- **Grease Point** is ergonomically located at standing height.
- **Cylinder Sleeve** provides replaceable protection for the cylinder, and drastically cuts labor for rebuilds.
- **Designed to Be Easily Rebuilt**, providing lasting value for your hammer investment.

### H75E s-H95E s Hammer Features:

- **Silencing** is standard on all H75E s and H95E s hammers.
- **Tri-suspension System** buffers the power cell, reducing noise and vibration.
- **Integral Accumulator** dampens pressure peaks and pulsation, thus protecting carrier hydraulic system.
- **Gas-fired Operating Cycle** delivers consistent, reliable performance over time.
- **Automatic Shut-off** protects the hammer from blank firing and reduces internal wear, protecting the hammer from less experienced operators.
- **Fully Enclosed Housing** protects the power cell, and is designed to eliminate stress points.
- **Gas Seal System** assures constant power is maintained between service intervals.
- **Single Grease Point** provides hammer paste to tool bushings. Grease point is ergonomically located at standing height making it comfortable for the operator to access.
- **Tool Changes** are simple: easily accomplished with common hand tools. Lower tool bushing can be serviced in the field.
- **Slip Fit Lower Tool Bushing** provides positive tool alignment, is field replaceable and rotatable.
- **Easy to Maintain** — Gas charges can be checked and filled with the hammer mounted on the machine.
- **Designed to Be Easily Rebuilt**, providing lasting value for your hammer investment.

**H110E s-H180E s Hammer Features:**

- **Unique Suspension System** — Improved recoil, support and guidance protects the carrier, increases hammer durability. Entire power cell is secured firmly inside housing. Noise suppression, operator feel and control is improved.
- **Auto Shut Off (ASO)** — Instantly stops the piston when breaking through material. Prevents blank firing, which is a top cause of hammer wear. Reducing wear improves maintenance and more productive hours of work.
- **Accumulator** — Self-contained membrane accumulator designed for long life. Port is accessible while hammer is mounted on the machine making testing and recharging a routine task achievable in the field.
- **Hydraulic Valves** — A Pressure Control Valve (PCV) maintains maximum hydraulic pressure to ensure the hammer delivers all blows at full power. PCV can be easily checked and adjusted from outside the hammer in about 30 minutes. A check valve (not shown) isolates harmful pulsation spikes from the carrier hydraulic circuit.
- **Autolube Connection and Grease Channel** — Provides grease to the upper and lower tool bushings to ensure proper greasing, longer life for bushings and tool.
- **Seal Carrier** — Contains special high performance seals to extend leak-proof operation.
- **Piston** — Long piston transfers a long shock wave into the rock. Tool-piston diameters are matched for maximum energy transfer.
- **Tie-Rods** — Larger threads improve load carrying capability, durability and reliability.
- **Cylinder** — Engineered to be durable and reliable with minimal maintenance and downtime.
- **Upper Tool Bushing** — Guides the tool to optimize in-line piston to tool contact.
- **Tool Retaining Pins and Keepers** — Tool removal process is simplified, achievable with common hand tools. Removal time reduced by 40% over previous models.
- **Lower Tool Bushing** — As bushing reaches the wear limit, it can be easily rotated (90°) or replaced to bring it back into specification. Dust seals keep contaminants out.

**NOTE:** Internal components of hammers are machined to close tolerances and require clean oil with full lubricating properties. When operating in high ambient temperatures or extreme temperature applications (e.g. foundries), higher viscosities are recommended to extend hammer life and improve performance. Hammers tend to shear multigrade mineral oil so that oil viscosity decreases. Contamination, water in oil, and decreased viscosity lead to earlier oil deterioration and the need for more frequent oil changes than normally recommended for the excavator. Extra care should be taken to avoid the entry of dust or dirt when installing or removing a hammer in the field.

**Small Hammer Tools**

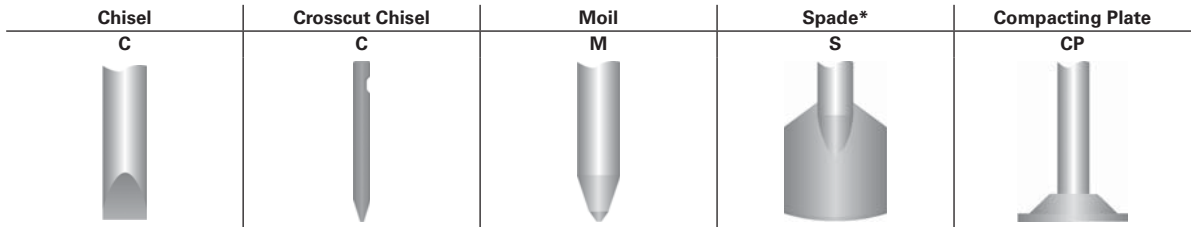

	H25D	H35E/Es	H45E/Es	H55E/Es	H65E/Es	H75 s	H95 s
<b>Road building/construction</b>							
Breaking of road surface	C, M	C, M, S	C, M, S	C, M, S	C, M, S	C, M, S	C, M
Asphalt cutting	C	C, S	C, S	C, S	C, S	C, S	C
Trench excavation for drainage						C, M	C, M
Demolition of bridges	C, M	C, M	C, M	C, M	C, M	C, M	C, M
Compacting soils		CP	CP	CP	CP	CP	
Making holes (for traffic signs, lamp posts)		M	M	M	M	M	M
Breaking of frozen ground	C, M	C, M, S	C, M, S	C, M, S	C, M, S	C, M, S	C, M
<b>Demolition/housing development</b>							
Demolition of concrete walls, roofs, floors	C, M	C, M	C, M	C, M	C, M	C, M	C, M
Demolition of light, reinforced concrete [<0.5 m (<20")]	M	M	M	M	M	M	M
Brick walls	C, M	C, M	C, M	C, M	C, M	C, M	C, M
Rock trenches for mains/water supply/utilities						C, M	C, M
Rock excavation for foundation							C, M
Separating rebar from concrete (for recycling)	C, M	C, M	C, M	C, M	C, M	C, M	C, M
<b>Quarrying/open cast mining</b>							
Breaking over sizes on a crusher/feeder/feed chute							C, M
Scaling						C	C
<b>Metallurgical applications</b>							
Breaking of slag in casting ladles							C, M
Cleaning of castings							C, M
Breaking of refractory linings in furnaces	C, M	C, M	C, M	C, M	C, M	C, M	C, M

\*Spade available as parallel (parallel with the boom) and transverse (perpendicular to the boom).

Large Hammer Tools

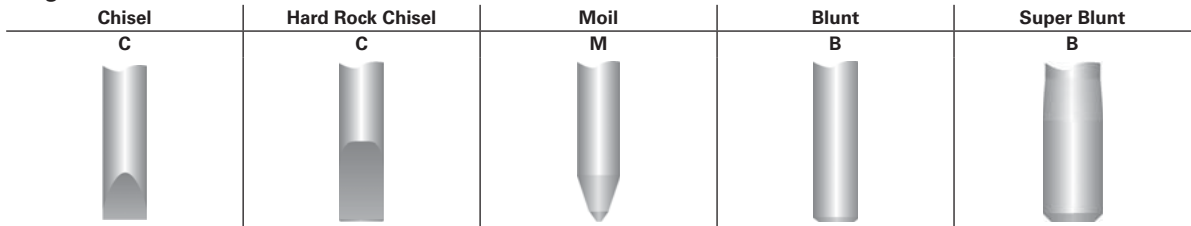

	H110E s	H115E s	H120E s	H130E s	H140E s	H160E s	H180E s
<b>Road building/construction</b>							
Breaking of road surface	C, M	C, M	C, M	C, M	C, M	C, M	C, M
Breaking uneven bedrock to lay a road	C, M	C, M	C, M	C, M	C, M	C, M	C, M
Primary breaking to prepare road bed					C, M	C, M	C, M
Trench excavation for drainage	C, M	C, M	C, M	C, M	C, M	C, M	C, M
Demolition of bridges	C, M	B, C, M	B, C, M	B, C, M	B, C, M	B, C, M	B, C, M
Heavily reinforced bridge pillars					B	B	B
Making holes (for traffic signs, lamp posts)	M	M	M	M	M	M	M
Breaking of frozen ground	C, M	C, M	C, M	C, M	C, M	C, M	C, M
<b>Demolition/housing development</b>							
Demolition of concrete walls, roofs, floors	C, M	B, C, M	B, C, M	B, C, M	B, C, M	B, C, M	B, C, M
Demolition of light, reinforced concrete [<0.5 m (<20")]	M	B, M	B, M	B, M			
Brick walls	C, M	B, C, M	B, C, M	B, C, M	B, C, M	B, C, M	B, C, M
Rock trenches for mains/water supply/utilities	C, M	C, M	C, M	C, M	C, M	C, M	C, M
Rock excavation for foundation	C, M	C, M	C, M	C, M	C, M	C, M	C, M
Mass excavation of rock for industrial building bases				C, M	C, M	C, M	C, M
Massive reinforced concrete foundations					M	M	M
Separating rebar from concrete (for recycling)	C, M	B, C, M	B, C, M	B, C, M	B, C, M	B, C, M	B, C, M
<b>Quarrying/open cast mining</b>							
Secondary boulder breaking	B	B	B	B	B	B	B
Primary breaking of rock				C, M	C, M	C, M	C, M
Breaking over sizes on a crusher/feeder/feed chute	C, M	B, C, M	B, C, M	B, C, M	B, C, M	B, C, M	
<b>Underground applications</b>							
Scaling	C	C					
<b>Metallurgical applications</b>							
Breaking of slag in casting ladles	C, M	C, M					
Breaking of slag in converter openings	C, M	C, M	C, M	C, M	C, M		
Cleaning of castings	C, M	C, M					
Breaking of massive steel slag						C, M	C, M
Breaking of aluminum electrolyze slag	C, M	C, M	C, M	C, M	C, M		
<b>Other applications</b>							
Demolition/rock breaking under water		C, M	C, M	C, M	C, M	C, M	C, M

Model	H25D		H35E/H35E s		H45E/H45E s		H55E/H55E s	
Working weight <sup>1</sup>	70 kg	<b>154 lb</b>	125-130 kg	<b>276-287 lb</b>	145-250 kg	<b>276-287 lb</b>	220-345 kg	<b>485-761 lb</b>
Impact frequency <sup>2</sup>	<b>1000-1900 bpm</b>		<b>600-1800 bpm</b>		<b>780-1800 bpm</b>		<b>600-1680 bpm</b>	
Hammer operating pressure <sup>3</sup>	12 000 kPa	<b>1740 psi</b>	16 500 kPa	<b>2393 psi</b>	16 500 kPa	<b>2393 psi</b>	17 000 kPa	<b>2465 psi</b>
Acceptable oil flow	15-25 L/min	<b>4-6.6 gpm</b>	12-35 L/min	<b>3-9 gpm</b>	25-62 L/min	<b>6.6-16 gpm</b>	30-85 L/min	<b>7.9-22 gpm</b>
Carrier weight class	0.8-1.1 t	<b>1764-2430 lb</b>	1.1-2.4 t	<b>2430-5300 lb</b>	1.5-3.2 t	<b>3310-7060 lb</b>	2.5-6.0 t	<b>5500-13,200 lb</b>

Model	H65E/H65E s		H75E s		H95E s		H110E s	
Working weight <sup>1</sup>	260-390 kg	<b>573-860 lb</b>	500 kg	<b>1103 lb</b>	627 kg	<b>1382 lb</b>	830 kg-1017 kg	<b>1826 lb-2237 lb</b>
Impact frequency <sup>2</sup>	<b>720-1740 bpm</b>		<b>840-1650 bpm</b>		<b>700-1260 bpm</b>		<b>450-1000 bpm</b>	
Hammer operating pressure <sup>3</sup>	17 000 kPa	<b>2465 psi</b>	14 500 kPa	<b>2100 psi</b>	14 500 kPa	<b>2100 psi</b>	16 000 kPa	<b>2320 psi</b>
Acceptable oil flow	40-115 L/min	<b>10-30 gpm</b>	70-130 L/min	<b>18-34 gpm</b>	70-150 L/min	<b>18-40 gpm</b>	60-120 L/min	<b>16-32 gpm</b>
Carrier weight class	3-9 t	<b>6600-19,800 lb</b>	6-10 t	<b>13,200-22,100 lb</b>	7-14 t	<b>15,400-30,900 lb</b>	7-16 t	<b>17,600-35,200 lb</b>

Model	H115E s		H120E s		H130E s	
Working weight <sup>1</sup>	1000-1180 kg	<b>2200-2596 lb</b>	1300-1580 kg	<b>2860-3476 lb</b>	1700-1890 kg	<b>3740-4158 lb</b>
Impact frequency <sup>2</sup>	<b>370-800 bpm</b>		<b>350-620 bpm</b>		<b>320-600 bpm</b>	
Hammer operating pressure <sup>3</sup>	15 000 kPa	<b>2175 psi</b>	15 000 kPa	<b>2175 psi</b>	15 000 kPa	<b>2175 psi</b>
Acceptable oil flow	70-130 L/min	<b>18-34 gpm</b>	100-170 L/min	<b>26-45 gpm</b>	120-220 L/min	<b>32-58 gpm</b>
Carrier weight class	12-20 t	<b>26,400-44,000 lb</b>	17-26 t	<b>37,400-57,200 lb</b>	19-32 t	<b>41,800-70,400 lb</b>

Model	H140E s		H160E s		H180E s	
Working weight <sup>1</sup>	2475 kg	<b>5457 lb</b>	3337 kg	<b>7358 lb</b>	4251 kg	<b>9373 lb</b>
Impact frequency <sup>2</sup>	<b>360-505 bpm</b>		<b>380-560 bpm</b>		<b>270-410 bpm</b>	
Hammer operating pressure <sup>3</sup>	16 000 kPa	<b>2320 psi</b>	16 000 kPa	<b>2320 psi</b>	16 000 kPa	<b>2320 psi</b>
Acceptable oil flow	160-230 L/min	<b>42-60 gpm</b>	220-300 L/min	<b>58-79 gpm</b>	220-300 L/min	<b>58-79 gpm</b>
Carrier weight class	24-42 t	<b>52,920-92,610 lb</b>	32-55 t	<b>70,560-121,275 lb</b>	42-76 t	<b>92,610-167,580 lb</b>

<sup>1</sup> Includes power cell, side plates/housing, average mounting bracket, where required, and standard tool.

<sup>2</sup> Approximate value, actual impact frequency depends on oil flow, oil viscosity, temperature, and hardness of material to be broken.

<sup>3</sup> Approximate value, operating pressure depends on oil flow, oil viscosity, temperature, material to be broken, and back pressure. Operating pressure is the result of correct low pressure adjustment.

Oil temperature working range for all models: -20° C to +80° C (-4° F to +176° F).

Oil viscosity at operating oil temperature: 15 to 1000 cSt.

### Principles of Selection

Key to the successful sale of a hammer is proper hammer selection.

### Background Information

Collection of background information is the first step. The following information will assist in being sure the customer receives the correct hammer and that he has a positive hammer experience. The following issues should be examined...

1. If any, what brand and model hammer was previously used and how did the hammer perform?
2. What % of time will the hammer be used on the machine?
3. Will the hammer be used in primary breaking or secondary breaking? (mainly an issue for large hammers)
4. What machine will the hammer be used on and what are the hydraulic flow and pressures of this machine?
5. What is the type of material to be broken and production required from the hammer? (best to obtain this from the end user but a table is available at the end of this section)

### Hammer Selection Process

1. Using Cat carrier matching matrix on next page identify 2 or 3 possible hammers for your application (for competitive carriers use carrier weight class as reference).
2. Compare machine/carrier flow and pressures to those of the hammer candidates to validate compatibility. Eliminate hammers outside carrier specs.
3. If hammer is to be used in primary breaking consider larger of hammer candidates.
4. Check productivity guidance tables at the back of this section. Identify hammer most compatible with requirements.
5. Determine if the application requires special hammer modifications, i.e. steel mill, underwater, tunneling, etc.

### Other Issues

Once the hammer has been chosen, other elements need to be considered to have a successful hammer experience.

1. Select the correct hammer tool for the application (see tool application chart in this section).
2. Check to be sure the correct hammer bracket and hoses are specified. Be sure correct carrier oil is specified for hammer use (particularly important in high ambient areas).
3. Consider supplemental carrier cooling in areas of high ambient temperature.

Actual operating pressure and back pressure **MUST** be checked when the hammer is fitted to the carrier (just as important if the hammer goes on a competitive carrier or is installed by the contractor at his shop).

### Guarding Recommendation

Hammers used in hazardous applications like demolition, quarrying, and scaling, can create a need for special operator guarding due to flying objects. When using a hammer, additional protective devices such as a front screen, Falling Object Guarding System (FOGS, includes top and front guarding), thick polycarbonate windshields or a combination of these is recommended by Caterpillar. Contact your Cat dealer for operator guarding options on your machine.

		H25D	H35E H35E s	H45E H45E s	H55E Pin-on	H55E H55E s Flat Top	H65E Pin-on	H65E H65E s Flat Top	H75E s
<b>Carrier weight</b>									
Minimum	<b>mt</b>	0.8	1.1	1.5	2.5	2.5	3.0	3.0	6.0
	<b>lb</b>	<b>1760</b>	<b>2430</b>	<b>3310</b>	<b>5500</b>	<b>5500</b>	<b>6610</b>	<b>6610</b>	<b>13,200</b>
Maximum	<b>mt</b>	1.1	2.4	3.2	6.0	6.0	9.0	9.0	10.0
	<b>lb</b>	<b>2430</b>	<b>5300</b>	<b>7060</b>	<b>13,200</b>	<b>13,200</b>	<b>19,800</b>	<b>19,800</b>	<b>22,100</b>
<b>Excavators</b>									
300.9D		•							
301.4C			•						
301.7D CR			•	•					
301.8C			•	•					
302.2D			•	•					
302.4D			•	•					
302.5C				•	•	•*			
302.7D CR				•	•	•*			
303.5D CR/303.5E CR					•	•	•		
304D CR/304E CR					•	•	•		
305D CR/305E CR					•	•	•	•	
305.5D CR/305.5E CR					•	•	•	•	
307D								•**	•
308D CR/308E CR SB/308E2 CR SB								•**	•
311D RR									
312D/312D L/312E/312E L									
314D CR/314E CR									
315D									
316E									
318E									
319D									
320D/320E									
320D RR/320E RR									
321D LCR									
324D									
324E									
328D LCR									
329D/329E									
336D/336E/336EH									
345D									
349E									
365C									
374D									

\*Installation of add-on optional counterweight to machine is required.

\*\*Hydraulic flows and pressures must be checked to verify they match the requirements for the hammer being installed.

**NOTE:** Caterpillar recommends the use of a suitable shield/guard system to insure operator has adequate protection from flying debris.

**NOTE:** These matches are for general reference purposes for Cat machines only. When special boom and quick coupler arrangements are used, these matches may not apply.

**NOTE:** When matching hammers to competitive carriers, selection should be made by carrier weight. Refer to the carrier range at the top of the table in order to determine the correct match.

		H95E s	H110E s	H115E s	H120E s	H130E s	H140E s	H160E s	H180E s
<b>Carrier weight</b>									
Minimum	<b>mt</b>	7.0	11.0	12.0	16.0	18.0	24.0	32.0	42.0
	<b>lb</b>	<b>15,400</b>	<b>24,300</b>	<b>26,500</b>	<b>35,300</b>	<b>39,700</b>	<b>52,920</b>	<b>70,600</b>	<b>92,600</b>
Maximum	<b>mt</b>	14.0	18.0	20.0	27.0	36.0	42.0	55.0	76.0
	<b>lb</b>	<b>30,900</b>	<b>39,700</b>	<b>44,100</b>	<b>59,500</b>	<b>79,400</b>	<b>92,600</b>	<b>121,300</b>	<b>167,600</b>
<b>Excavators</b>									
300.9D									
301.4C									
301.7D CR									
301.8C									
302.2D									
302.4D									
302.5C									
302.7D CR									
303.5D CR/303.5E CR									
304D CR/304E CR									
305D CR/305E CR									
305.5D CR/305.5E CR									
307D		•							
308D CR/308E CR SB/308E2 CR SB		•							
311D RR		•	•						
312D/312D L/312E/312E L		•	•	•					
314D CR/314E CR			•	•					
315D			•	•	•				
316E			•	•	•				
318E				•	•	•			
319D				•	•	•			
320D/320E				•	•	•			
320D RR/320E RR				•	•	•			
321D LCR					•	•			
324D					•	•	•		
324E					•	•	•		
328D LCR						•	•		
329D/329E					•	•	•		
336D/336E/336EH							•	•	
345D								•	•
349E								•	•
365C									•
374D									•

\*Installation of add-on optional counterweight to machine is required.

\*\*Hydraulic flows and pressures must be checked to verify they match the requirements for the hammer being installed.

**NOTE:** Caterpillar recommends the use of a suitable shield/guard system to insure operator has adequate protection from flying debris.

**NOTE:** These matches are for general reference purposes for Cat machines only. When special boom and quick coupler arrangements are used, these matches may not apply.

**NOTE:** When matching hammers to competitive carriers, selection should be made by carrier weight. Refer to the carrier range at the top of the table in order to determine the correct match.



		H25D	H35E H35E s	H45E H45E s	H55E Pin-on	H55E H55E s Flat Top	H65E Pin-on	H65E H65E s Flat Top	H75E s
<b>Carrier weight</b>									
Minimum	<b>mt</b>	0.8	1.1	1.5	2.5	2.5	3.0	3.0	6.0
	<b>lb</b>	<b>1760</b>	<b>2430</b>	<b>3310</b>	<b>5500</b>	<b>5500</b>	<b>6610</b>	<b>6610</b>	<b>13,200</b>
Maximum	<b>mt</b>	1.1	2.4	3.2	6.0	6.0	9.0	9.0	10.0
	<b>lb</b>	<b>2430</b>	<b>5300</b>	<b>7060</b>	<b>13,200</b>	<b>13,200</b>	<b>19,800</b>	<b>19,800</b>	<b>22,100</b>
<b>Wheeled Excavators</b>									
M313C/M313D									
M315C/M315D									
M316C/M316D									
M318C/M318D									
M322C/M322D									
<b>Skid Steer and Multi-Terrain Loaders</b>									
216B2/216B3					•	•	•	•	
226B2/226B3					•	•	•	•	
236B3/236D					•	•	•	•	
242B3/242D					•	•	•	•	
246C/246D					•	•	•	•	
247B2/247B3					•	•	•	•	
252B2/252B3					•	•	•	•	
257B3/257D					•	•	•	•	
259B3/259D					•	•	•	•	
262C2/262D					•	•	•	•	
272D/272D XHP					•	•	•	•	
277C2/277D					•	•	•	•	
279C2/279D					•	•	•	•	
287C2/287D					•	•	•	•	
289C2/289D					•	•	•	•	
297C					•	•	•	•	
299C/299D/299D XHP					•	•	•	•	
<b>Backhoes</b>									
BH30/BH30W					•	•			
BH150/BH160					•	•	•		
<b>Backhoe Loaders</b>									
416E/416F								•**	•
420E/420F								•**	•
430E/430F								•**	•
446D									
450E/450F									

\*Installation of add-on optional counterweight to machine is required.

\*\*Hydraulic flows and pressures must be checked to verify they match the requirements for the hammer being installed.

NOTE: Caterpillar recommends the use of a suitable shield/guard system to insure operator has adequate protection from flying debris.

NOTE: These matches are for general reference purposes for Cat machines only. When special boom and quick coupler arrangements are used, these matches may not apply.

NOTE: When matching hammers to competitive carriers, selection should be made by carrier weight. Refer to the carrier range at the top of the table in order to determine the correct match.

		H95E s	H110E s	H115E s	H120E s	H130E s	H140E s	H160E s	H180E s
<b>Carrier weight</b>									
Minimum	<b>mt</b>	7.0	11.0	12.0	16.0	18.0	24.0	32.0	42.0
	<b>lb</b>	<b>15,400</b>	<b>24,300</b>	<b>26,500</b>	<b>35,300</b>	<b>39,700</b>	<b>52,920</b>	<b>70,600</b>	<b>92,600</b>
Maximum	<b>mt</b>	14.0	18.0	20.0	27.0	36.0	42.0	55.0	76.0
	<b>lb</b>	<b>30,900</b>	<b>39,700</b>	<b>44,100</b>	<b>59,500</b>	<b>79,400</b>	<b>92,600</b>	<b>121,300</b>	<b>167,600</b>
<b>Wheeled Excavators</b>									
M313C/M313D			•	•					
M315C/M315D			•	•	•				
M316C/M316D			•	•	•				
M318C/M318D				•	•	•			
M322C/M322D				•	•	•			
<b>Skid Steer and Multi-Terrain Loaders</b>									
216B2/216B3									
226B2/226B3									
236B3/236D									
242B3/242D									
246C/246D									
247B2/247B3									
252B2/252B3									
257B3/257D									
259B3/259D									
262C2/262D									
272D/272D XHP									
277C2/277D									
279C2/279D									
287C2/287D									
289C2/289D									
297C									
299C/299D/299D XHP									
<b>Backhoes</b>									
BH30/BH30W									
BH150/BH160									
<b>Backhoe Loaders</b>									
416E/416F		•							
420E/420F		•							
430E/430F		•							
446D		•	•						
450E/450F		•	•						

\*Installation of add-on optional counterweight to machine is required.

\*\*Hydraulic flows and pressures must be checked to verify they match the requirements for the hammer being installed.

**NOTE:** Caterpillar recommends the use of a suitable shield/guard system to insure operator has adequate protection from flying debris.

**NOTE:** These matches are for general reference purposes for Cat machines only. When special boom and quick coupler arrangements are used, these matches may not apply.

**NOTE:** When matching hammers to competitive carriers, selection should be made by carrier weight. Refer to the carrier range at the top of the table in order to determine the correct match.

**Productivity Rates: 8 hour shift**

Production rates listed are for general estimation purposes only and must not be used to guarantee any production figure to the customer. The actual working results may vary according to the quality and structure of the material to be broken, required degree of material size reduction, installation, condition of the carrier, conditions at the work site, haulage of the broken material, skills of the operator, etc.

<b>Hammer Models</b>	<b>Non-Reinforced Concrete</b>		<b>Reinforced Concrete</b>		<b>Sedimentary Rock</b>		<b>Volcanic Rock</b>	
H35E/E s	6-12 m <sup>3</sup>	<b>8-16 yd<sup>3</sup></b>						
H45E/E s	8-18 m <sup>3</sup>	<b>10-23 yd<sup>3</sup></b>						
H55E/E s	14-23 m <sup>3</sup>	<b>18-30 yd<sup>3</sup></b>						
H65E/E s	45-90 m <sup>3</sup>	<b>34-69 yd<sup>3</sup></b>						
H75E s	65-107 m <sup>3</sup>	<b>85-140 yd<sup>3</sup></b>	19-46 m <sup>3</sup>	<b>25-60 yd<sup>3</sup></b>				
H95E s	69-122 m <sup>3</sup>	<b>90-160 yd<sup>3</sup></b>	38-61 m <sup>3</sup>	<b>50-80 yd<sup>3</sup></b>				
H110E s	99-214 m <sup>3</sup>	<b>130-280 yd<sup>3</sup></b>	96-134 m <sup>3</sup>	<b>125-175 yd<sup>3</sup></b>	84-121 m <sup>3</sup>	<b>110-250 yd<sup>3</sup></b>	42-99 m <sup>3</sup>	<b>55-130 yd<sup>3</sup></b>
H115E s	115-287 m <sup>3</sup>	<b>150-375 yd<sup>3</sup></b>	107-184 m <sup>3</sup>	<b>140-240 yd<sup>3</sup></b>	126-229 m <sup>3</sup>	<b>165-300 yd<sup>3</sup></b>	57-115 m <sup>3</sup>	<b>75-150 yd<sup>3</sup></b>
H120E s	153-344 m <sup>3</sup>	<b>200-450 yd<sup>3</sup></b>	122-229 m <sup>3</sup>	<b>160-300 yd<sup>3</sup></b>	153-260 m <sup>3</sup>	<b>200-340 yd<sup>3</sup></b>	84-153 m <sup>3</sup>	<b>110-200 yd<sup>3</sup></b>
H130E s	210-375 m <sup>3</sup>	<b>275-490 yd<sup>3</sup></b>	153-268 m <sup>3</sup>	<b>200-350 yd<sup>3</sup></b>	191-306 m <sup>3</sup>	<b>250-400 yd<sup>3</sup></b>	103-210 m <sup>3</sup>	<b>135-210 yd<sup>3</sup></b>
H140E s			191-497 m <sup>3</sup>	<b>250-650 yd<sup>3</sup></b>	229-535 m <sup>3</sup>	<b>300-700 yd<sup>3</sup></b>	115-268 m <sup>3</sup>	<b>150-350 yd<sup>3</sup></b>
H160E s			229-650 m <sup>3</sup>	<b>300-850 yd<sup>3</sup></b>	268-688 m <sup>3</sup>	<b>350-900 yd<sup>3</sup></b>	153-459 m <sup>3</sup>	<b>200-600 yd<sup>3</sup></b>
H180E s			295-1301 m <sup>3</sup>	<b>385-1705 yd<sup>3</sup></b>	337-1345 m <sup>3</sup>	<b>440-1760 yd<sup>3</sup></b>	210-757 m <sup>3</sup>	<b>275-990 yd<sup>3</sup></b>

The figures are for comparison and evaluation purposes only. Results will vary depending on operator, carrier and job conditions.

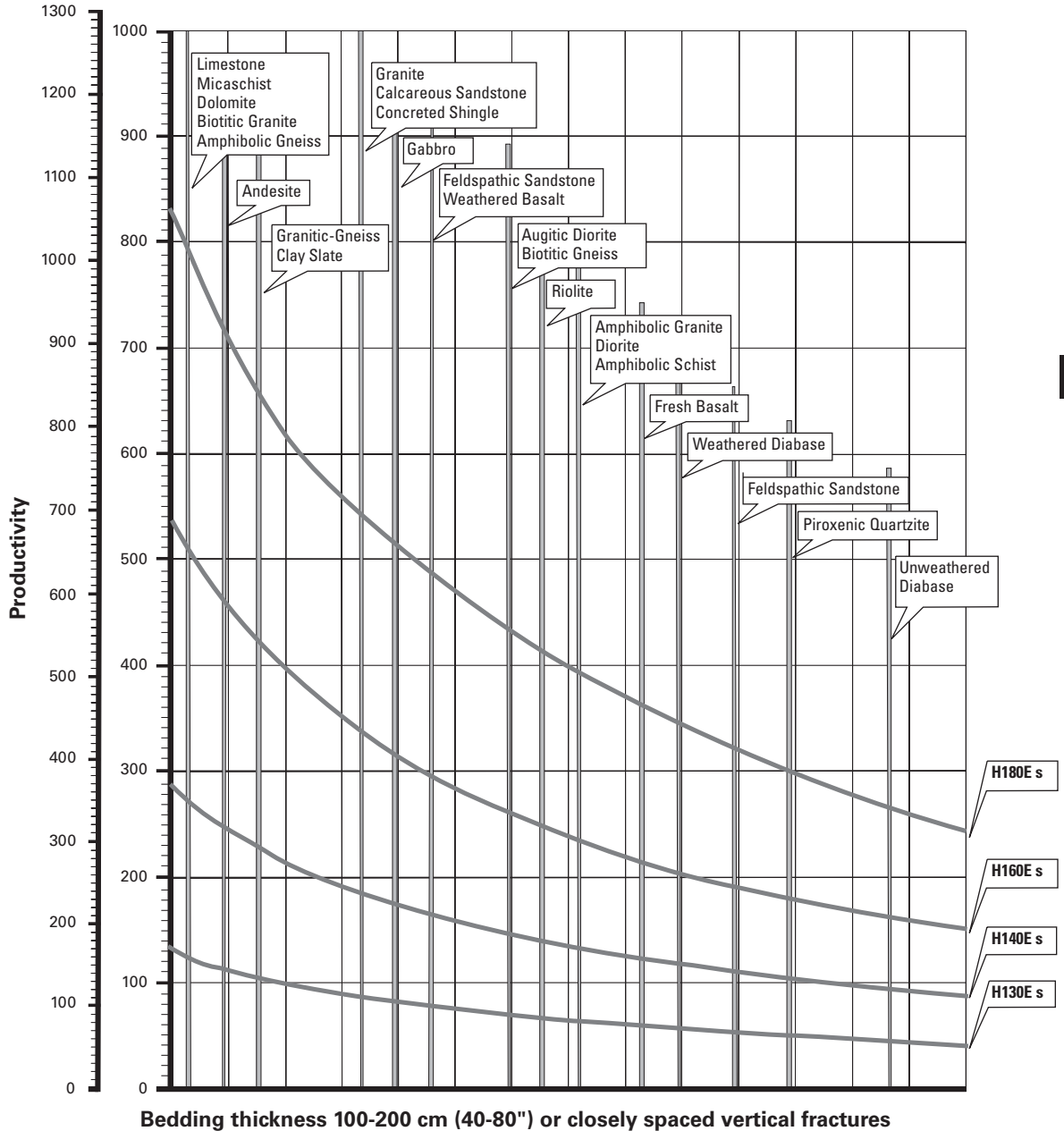

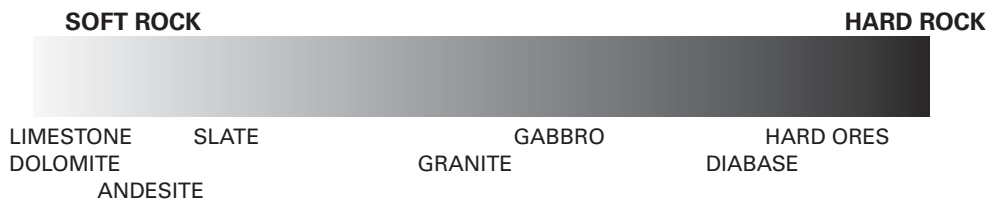
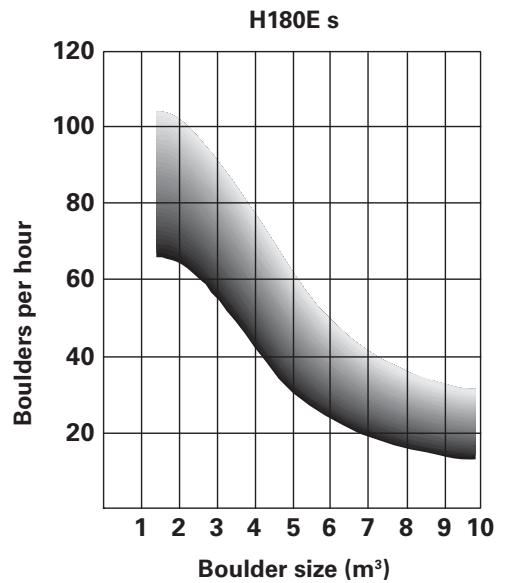
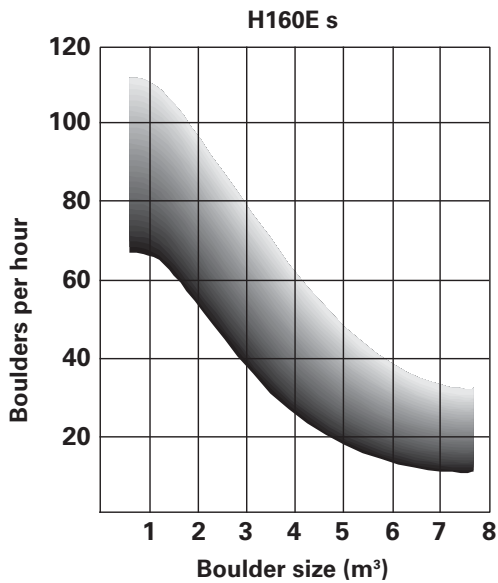
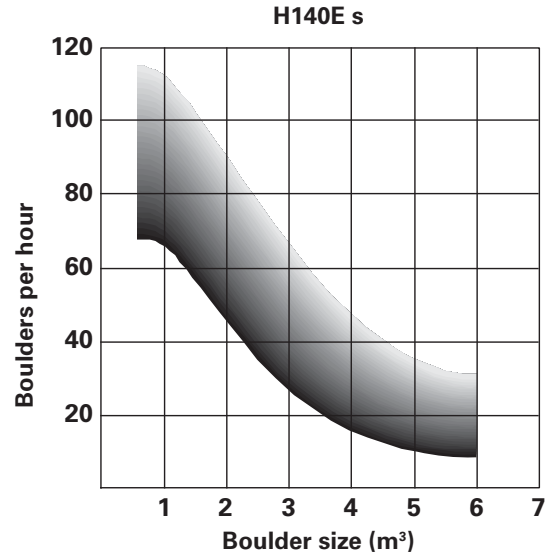
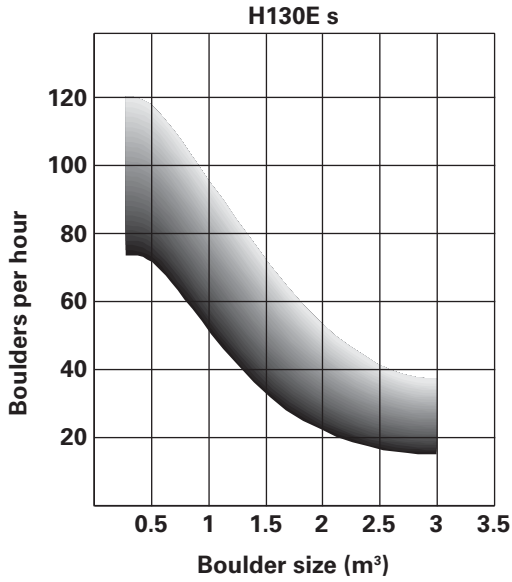

## MOBILE SCRAP AND DEMOLITION SHEARS

C Series Shears incorporate a bolt-on piercing tip — a key feature for enhancing up time for shears.

- Changeable with common hand tools.
- Dual-sided protecting the moving jaw on both sides.
- Fully reversible tip and blades.

Cat Mobile Scrap and Demolition Shears are available in six sizes and feature:

- Straight lower, apex upper jaw design.
- 360 degree bidirectional rotation system.
- Adjustable hub allows users to maintain tolerances between the jaws in the field.
- High force to weight ratio.
- Long wearing alloy steel blades.
- Cutting edges mounted on the side of the shear jaws and are visible to the operator.
- Shears can be mounted on boom or stick.

### Applications:

Cat Mobile Scrap and Demolition Shears are designed to cut and reduce the size of metal items commonly found in scrap yards, buildings, and other structures.

The profiles on the next page approximate shear cutting capacity. The cutting capacities listed on the next page were achieved by cutting the specified steel profiles with a shear operating pressure at 35 000 kPa (5075 psi) and knives in slightly used condition. Lower operating pressures, dull knife edges, and harder steels will obviously reduce cutting capability.

### Guarding Recommendation

Shears used in hazardous applications like demolition, and scrap and material handling can create a need for special operator guarding due to flying or falling objects. When using a shear, additional protective devices such as a front screen, Falling Object Guarding System (FOGS, includes top and front guarding), thick polycarbonate windshields or a combination of these is recommended by Caterpillar. Contact your Cat dealer for operator guarding options on your machine.

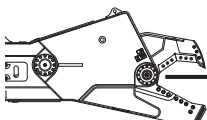
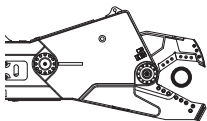
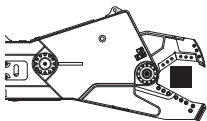
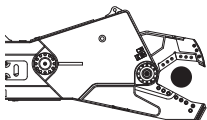
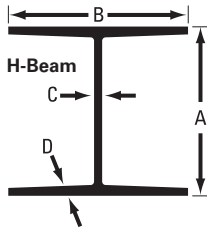
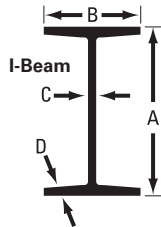

Model		S385C	S365C	S340B	S325B	S320B	S305
		<b>I-Beams</b>					
<b>A</b> Height	mm (in)	635 (25)	612 (24.1)	457.2 (18)	407 (16)	358 (14.1)	207 (8.1)
<b>B</b> Flange width	mm (in)	329 (13)	229 (9)	191 (7.5)	178 (7.0)	172 (6.8)	112 (4.4)
<b>C</b> Web thickness	mm (in)	18 (0.7)	12 (0.5)	9.017 (0.4)	7.7 (0.3)	7.8 (0.3)	5.8 (0.2)
<b>D</b> Flange thickness	mm (in)	31 (1.2)	20 (0.8)	15.24 (0.6)	12.7 (0.5)	12.7 (0.5)	8.4 (0.3)
Weight	kg/m (ft-lb)	241 (162)	125 (84)	74.4 (50)	59.5 (40)	56.5 (38)	22.3 (15)
		<b>Wide I-Beams</b>			<b>H-Beams</b>		
<b>A</b> Height	mm (in)	476 (18.7)	472 (18.6)	311 (12.2)	256 (10.1)	204 (8)	107 (4.2)
<b>B</b> Flange width	mm (in)	284 (11.2)	284 (11.2)	306 (12)	255 (10)	206 (8.1)	103 (4.1)
<b>C</b> Web thickness	mm (in)	24 (0.9)	13 (0.5)	10.9 (0.4)	9.4 (0.4)	7.9 (0.3)	7.11 (0.3)
<b>D</b> Flange thickness	mm (in)	15 (0.6)	22 (0.9)	10.9 (0.4)	9.4 (0.4)	7.9 (0.3)	8.8 (0.3)
Weight	kg/m (ft-lb)	158 (106)	144 (97)	107 (71.9)	80 (53.8)	52 (34.9)	19.4 (13)

<b>Round</b>							
Diameter	mm (in)	125 (5)	120 (4.75)	115 (4.5)	100 (4)	90 (3.5)	50.8 (2)

<b>Square</b>							
Width	mm (in)	120 (4.75)	100 (4)	90 (3.5)	90 (3.5)	65 (2.5)	40 (1.5)

<b>Pipe (Schedule 40)</b>							
Diameter	mm (in)	508 (20)	458 (18)	406 (16)	356 (14)	325 (12.8)	220 (8.6)
Wall thickness	mm (in)	15 (0.6)	15 (0.6)	13 (0.5)	11 (0.4)	10 (0.4)	8 (0.3)

<b>Piercing</b>							
Thickness	mm (in)	33 (1.38)	27 (1.25)	22 (0.88)	19 (0.75)	16 (0.63)	10 (0.38)

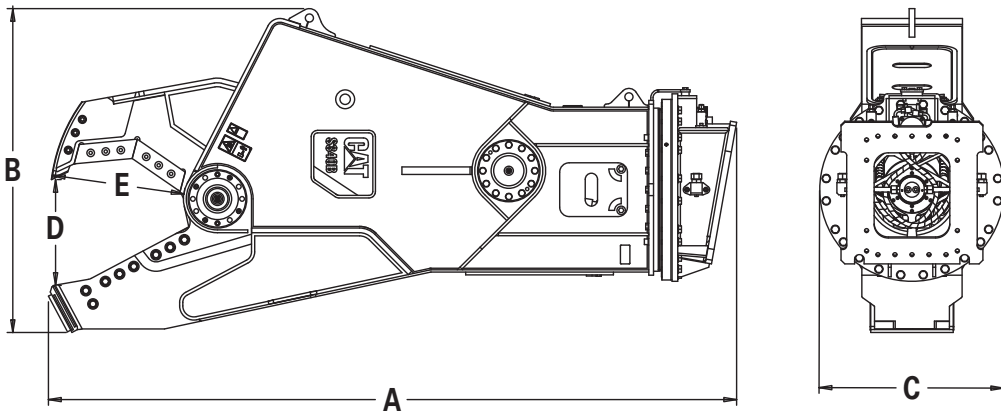

Model		S385C	S365C	S340B	S325B	S320B	S305
Weight*, boom-mount	kg	8320	6870	4695	3390	2570	608
	(lb)	(18,345)	(15,145)	(10,351)	(7474)	(5666)	(1340)
Weight*, stick-mount	kg	7975	6700	4386	2996	2165	580
	(lb)	(17,580)	(14,770)	(9670)	(6604)	(4774)	(1280)
<b>Dimensions</b>							
<b>A</b> Length	mm	4260	3840	3638	3177	2792	1709
	(in)	(168)	(151)	(143)	(125)	(110)	(67.3)
<b>B</b> Height	mm	2121	1900	1723	1525	1340	660
	(in)	(84)	(75)	(68)	(60)	(53)	(26)
<b>C</b> Width	mm	1400	1180	975	792	792	390
	(in)	(55)	(46)	(38)	(31)	(31)	(15)
Jaw width, fixed	mm	466	466	396	342	304	230
	(in)	(18)	(18)	(16)	(13)	(12)	(9)
Jaw width, moving	mm	150	150	120	100	90	60
	(in)	(6)	(6)	(5)	(4)	(3)	(2)
<b>D</b> Jaw opening	mm	879	845	563	528	409	240
	(in)	(35)	(33)	(22)	(21)	(16)	(9.4)
<b>E</b> Jaw depth	mm	903	840	703	571	459	290
	(in)	(35)	(33)	(28)	(22)	(18)	(11.4)

\*Weight includes mounting bracket.



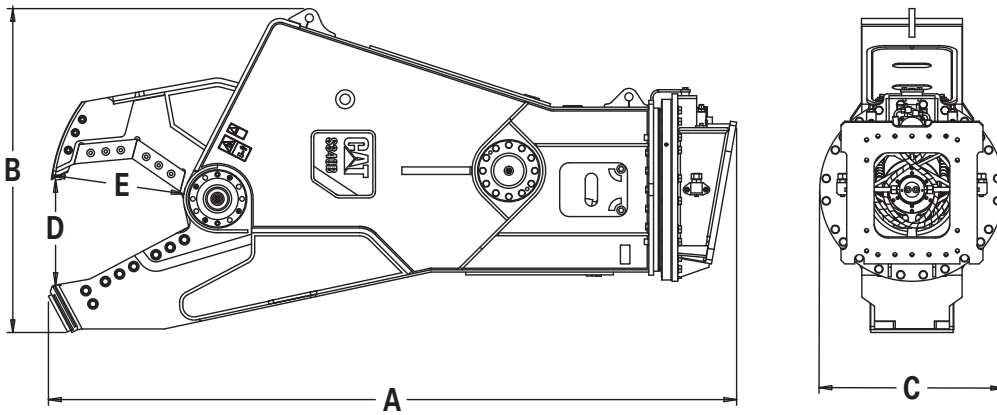

<b>Model</b>		<b>S385C</b>	<b>S365C</b>	<b>S340B</b>	<b>S325B</b>	<b>S320B</b>	<b>S305</b>
<b>Shear Forces*</b>							
Throat**	<b>kN</b>	12 509	10 342	6818	5562	3706	1812
	<b>(st)</b>	<b>(1405)</b>	<b>(1162)</b>	<b>(766)</b>	<b>(625)</b>	<b>(417)</b>	<b>(204)</b>
Apex	<b>kN</b>	4413	3576	2751	2221	1583	653
	<b>(st)</b>	<b>(496)</b>	<b>(402)</b>	<b>(309)</b>	<b>(250)</b>	<b>(178)</b>	<b>(73)</b>
Tip	<b>kN</b>	2455	1975	1558	1274	892	385
	<b>(st)</b>	<b>(276)</b>	<b>(222)</b>	<b>(175)</b>	<b>(143)</b>	<b>(100)</b>	<b>(43)</b>
Shear arm torque	<b>kN·m</b>	2779	2083	1374	931	534	140
	<b>(lbf·ft)</b>	<b>(2,050,000)</b>	<b>(1,536,000)</b>	<b>(1,013,700)</b>	<b>(686,900)</b>	<b>(394,100)</b>	<b>(103,600)</b>
Cycle time, open	<b>seconds</b>	<b>5</b>	<b>5</b>	<b>5</b>	<b>5</b>	<b>4</b>	<b>3.5</b>
Cycle time, close	<b>seconds</b>	<b>3</b>	<b>3</b>	<b>3</b>	<b>3</b>	<b>3</b>	<b>2.5</b>
<b>Hydraulic Requirements, Cutting Circuit</b>							
Maximum relief pressure	<b>kPa</b>	35 000	35 000	35 000	35 000	35 000	25 000
	<b>(psi)</b>	<b>(5075)</b>	<b>(5075)</b>	<b>(5075)</b>	<b>(5075)</b>	<b>(5075)</b>	<b>(3625)</b>
Maximum recommended flow	<b>L/min</b>	690	530	300	200	150	60
	<b>(gpm)</b>	<b>(182)</b>	<b>(140)</b>	<b>(79)</b>	<b>(53)</b>	<b>(40)</b>	<b>(16)</b>
<b>Hydraulic Requirements, Rotation Circuit</b>							
Maximum relief pressure	<b>kPa</b>	14 000	14 000	14 000	14 000	14 000	10 000
	<b>(psi)</b>	<b>(2030)</b>	<b>(2030)</b>	<b>(2030)</b>	<b>(2030)</b>	<b>(2030)</b>	<b>(1450)</b>
Maximum recommended flow	<b>L/min</b>	80	80	40	40	40*	20
	<b>(gpm)</b>	<b>(21)</b>	<b>(21)</b>	<b>(11)</b>	<b>(11)</b>	<b>(11*)</b>	<b>(5)</b>

\*Calculated with a maximum operating pressure of 35 MPa (5075 psi).

\*\*Measured at innermost cutting point of the jaw.

**Matching Guide**

Pin-On matches are shown below.

Matches are based on counterweight and grouser width on standard machines.

Wheeled excavator matches are calculated with all four stabilizers down.

**Stick-Mount**

Cat Excavator	Boom	Stick		S385C	S365C	S340B	S325B	S320B	S305
		m	(ft/in)						
<b>390D L</b>	GP	5.5	(18'1")		X				
		4.4	(14'5")	X	X				
		3.4	(11'2")	X	X				
		3.7	(12'2")	X	X				
		2.92	(9'7")	X	X				
<b>374D L</b>	Reach	4.15	(13'7")		X				
		3.6	(11'10")		X				
		2.84	(9'4")		X				
<b>345D L – VG</b>	Reach	3.9	(12'10")			X			
		3.35	(11'0")			X			
<b>345D – FIX</b>	Reach	3.9	(12'10")			X	X		
		3.3	(11'0")			X	X		
<b>345C – DEM</b>		28	(91'9")					X	
		26	(85'0")					X	
<b>336D L/330D L</b>	Reach	3.9	(12'10")				X	X	
		3.2	(10'6")				X	X	
<b>329D L/325D L</b>	Reach	3.2	(10'6")				X	X	
							X	X	
							X	X	
<b>328D LCR</b>	Reach	3.76	(12'4")					X	
		3.2	(10'6")				X	X	
		2.65	(8'8")				X	X	
<b>324D L</b>	Reach	3.6	(11'10")					X	
		2.95	(9'8")				X	X	
		2.5	(8'2")				X	X	
<b>321D LCR</b>	Reach	2.92	(9'6")					X	
		2.5	(8'2")					X	
<b>320D L</b>	Reach	2.92	(9'6")					X	
		2.5	(8'2")					X	
<b>320D LRR</b>	Reach	2.92	(9'6")					X	
		2.5	(8'2")					X	
	Reach-HD	2.92	(9'6")					X	
		2.5	(8'3")					X	
<b>319D L</b>	Reach	2.7	(8'10")					X	
		2.25	(7'5")					X	
<b>M322D</b>	One-Piece	2.5	(8'2")					X	
		2.2	(7'3")					X	
<b>M318D</b>	One-Piece	2.8	(9'2")					X	
		2.5	(8'2")					X	
		2.2	(7'3")					X	
<b>M316D</b>	One-Piece	2.4	(7'10")					X	
		2.1	(6'11")					X	
<b>M315D</b>	One-Piece	2.4	(7'10")					X	
		2.1	(6'11")					X	
<b>308D CR</b>	One-Piece	2.2	(7'3")						X
		1.7	(5'6")						X
<b>307D</b>	One-Piece	2.2	(7'3")						X
		1.7	(5'6")						X

Pin-on matches are shown above. Please reference bulletin GEJH0016 for matching information when utilizing a pin-grabber or dedicated coupler.

DEM = Demolition machine

VG = Variable wide gauge undercarriage

FIX = Fixed undercarriage

**Matching Guide**

Matches are based on counterweight and grouser width on standard machines.  
Wheeled excavator matches are calculated with all four stabilizers down.

**Boom-Mount**

Cat Excavator	Boom	S385C	S365C	S340B	S325B	S320B	S305
365C L	Reach	X					
345D L – VG	Reach	X	X				
345D – FIX	Reach	X	X				
336D L/330D L	Reach		X	X			
329D L/325D L	Reach			X			
328D L CR	Reach			X			
324D L	Reach			X			
321D L CR	Reach						
320D L	Reach				X		
320D LRR	Reach				X		
	Reach-HD				X		
319D L	Reach				X	X	
315D L	Reach				X	X	
314D CR	Reach					X	
312D L	Reach					X	
311D LRR	Reach					X	
M322D	One-Piece			X			
M318D	One-Piece			X	X		
M316D	One-Piece			X	X		
M315D	One-Piece				X	X	
M313D	One-Piece				X	X	
305D CR	One-Piece						X
304D CR	One-Piece						X
303.5D CR	One-Piece						X

**Cat S305 is a match for all Skid Steer Loaders 236B2 and larger and all Multi-Terrain Loaders.**

Please reference bulletin GEJH0016 for matching information when utilizing a pin-grabber or dedicated coupler.

VG = Variable wide gauge undercarriage

FIX = Fixed undercarriage

## MULTI-PROCESSORS

### Features:

- **Wide selection** of interchangeable jaws.
- **Lifting eye placement** and adjustable stop bolts allow quick jaw changes.
- **Single, large diameter** cross mounted cylinder provides exceptional cutting and crushing force.
- **Jaws are manufactured** of high quality tool steel with outstanding tensile strength.
- **Non impact** tools that work at a relatively low noise level.

### Applications:

The Cat Multi-Processors can be used to accomplish most tasks on a demolition job. One common housing with a wide selection of interchangeable jaws allows the tool to cut, crush or pulverize the toughest of materials. Highly reinforced concrete, structural steel beams, pipes, cable, steel plate and storage tanks.

## Matching Guide

### Stick Mounted/Reach Boom

Multi-Processors Model	Cat Excavator
<b>MP318</b>	318E, 319D, 320D/E, 320D/E RR, 321D CR, 323D/E, 324D/E M315D, M316D, M318D, M322D, M318D MH, M322 MH DEM50, DEM70, DEM100
<b>MP324</b>	323D, 324D/E, 328D CR, 329D/E, 336D/E DEM50, DEM70, DEM100
<b>MP30</b>	330D 345C 365C UHD, 385C UHD
<b>MP40</b>	365C, 385C

These matches are for general reference purpose for Cat machines only. Please always check the stability of the machine-tool configuration. The stability depends on application, tool used and your machine configuration. For questions please contact your Cat dealer. When choosing between various multi-processor models that can be installed onto the same machine configuration, consider work tool application, productivity requirements, and durability.

## CAT MULTI-PROCESSOR INTERCHANGEABLE JAWS

### Concrete Cutter Jaws (CC)

- For precise demolition/cutting of heavily reinforced concrete structures.
- Cuts structural steel and pipe.
- Equipped with replaceable concrete crusher teeth and reversible steel cutting knives.

### Shear Jaws (S)

- For demolition of steel structures.
- Cuts angle and channel iron, beams, pipe, rebar, cable and tires.
- Knives are reversible.

### Tank Shear Jaws (TS)

- Quickly cuts steel plate on barges, railway cars, grain, water, oil, and fuel tanks. Dual knives on the moving and static jaws produce smooth, straight edges.
- All knives are reversible.
- Available for MP20 and MP30 only.

### Crusher Jaws (CR)

- For demolition of moderately reinforced concrete structures. Capable of crushing concrete and cutting rebar.
- Replaceable crusher teeth and reversible knives.

### Primary Pulverizer Jaws (PP)

- Combines capability to demolish and recycle moderately reinforced concrete structures. Pulverizes concrete, cuts rebar and separates rebar from concrete. (Not available for MP40.)
- Replaceable crusher teeth and reversible knives.

### Secondary Pulverizer Jaws (PS)

- Recycles demolished concrete by pulverizing concrete, separating concrete and rebar, and cutting rebar as needed.

**All jaw sets can be interchanged quickly with the lifting eyes and the adjustable stopbolts on jaws and body.**

**Guarding Recommendation**

Multi-Processors used in hazardous applications like demolition, and scrap and material handling can create a need for special operator guarding due to flying or falling objects. When using a Multi-Processor, additional protective devices such as a front screen, Falling Object Guarding System (FOGS, includes top and front guarding), thick polycarbonate windshields or a combination of these is recommended by Caterpillar. Contact your Cat dealer for operator guarding options on your machine.

**Specifications** (All dimensions are approximate.)

<b>Model</b>	<b>MP318</b>		<b>MP324</b>	
Carrier weight	18-25 mt	<b>39,500-55,000 lb</b>	24-35 mt	<b>53,000-77,000 lb</b>
Housing weight, jaw	1930 kg	<b>4255 lb</b>	2610 kg	<b>5754 lb</b>
Weight of the jaw	660-850 kg	<b>1455-1874 lb</b>	940-1160 kg	<b>2072-2557 lb</b>
Maximum pressure (open/close)	350 bar	<b>5076 psi</b>	350 bar	<b>5076 psi</b>
Flow (open/close)	150 L/min	<b>33 gpm</b>	225 L/min	<b>50 gpm</b>
Pressure rotation	140 bar	<b>2030 psi</b>	140 bar	<b>2030 psi</b>
Flow rotation	40 L/min	<b>10.6 gpm</b>	40 L/min	<b>10.6 gpm</b>
Return flow opening	240 L/min	<b>53 gpm</b>	370L/min	<b>81 gpm</b>
Cycle time (open/close)	<b>1.6/1.0 sec</b>		<b>1.8/1.2 sec</b>	
<b>Model</b>	<b>MP30</b>		<b>MP40</b>	
Weight total — housing, jaw and bracket	3850 kg	<b>8190 lb</b>	6370 kg	<b>14,045 lb</b>
Weight of the jaw	1260 kg	<b>2780 lb</b>	2230 kg	<b>4915 lb</b>
Dimensions:				
Length	2800 mm	<b>110.2"</b>	3500 mm	<b>137.8"</b>
Height	1980 mm	<b>78"</b>	2340 mm	<b>92.1"</b>
Width	1010 mm	<b>39.8"</b>	1180 mm	<b>46.5"</b>
Jaw width (fixed)	380 mm	<b>15"</b>	460 mm	<b>18.1"</b>
Jaw width (moving)	130 mm	<b>5.1"</b>	160 mm	<b>6.3"</b>
Jaw opening	975 mm	<b>38.4"</b>	1280 mm	<b>50.4"</b>
Jaw depth	890 mm	<b>35"</b>	1100 mm	<b>43.3"</b>
Cutter length	520 mm	<b>20.5"</b>	600 mm	<b>23.6"</b>
Maximum crushing/shear force:				
Tooth — jaw tip	1250 kN	<b>140 st</b>	1500 kN	<b>168 st</b>
Front cutter tip	1850 kN	<b>208 st</b>	2200 kN	<b>247 st</b>
Primary blade center	4100 kN	<b>460 st</b>	4400 kN	<b>494 st</b>
Maximum oil flow:				
Hydraulic cylinder	300 L/min	<b>79 gpm</b>	400 L/min	<b>106 gpm</b>
Cycle time (open, close, open)	<b>6.5 sec</b>		<b>7.5 sec</b>	
Rotation	40 L/min	<b>11 gpm</b>	80 L/min	<b>22 gpm</b>
Maximum working pressure:				
Hydraulic cylinder	35 000 kPa	<b>5075 psi</b>	35 000 kPa	<b>5075 psi</b>
Rotation	14 000 kPa	<b>2030 psi</b>	14 000 kPa	<b>2030 psi</b>

**Specifications** (All dimensions are approximate.)

<b>Jaw Type</b>	<b>MP318-CC</b>		<b>MP318-D</b>		<b>MP318-P</b>		<b>MP318-S</b>		<b>MP318-U</b>	
Housing weight, jaw	1930 kg	<b>4255 lb</b>	1910 kg	<b>4211 lb</b>	2030 kg	<b>4475 lb</b>	1840 kg	<b>4056 lb</b>	1980 kg	<b>4365 lb</b>
Weight of the jaw	750 kg	<b>1653 lb</b>	730 kg	<b>1609 lb</b>	850 kg	<b>1874 lb</b>	660 kg	<b>1455 lb</b>	770 kg	<b>1697 lb</b>
Closing force:										
Tooth tip	75 mt	<b>83 st</b>	75 mt	<b>83 st</b>	75 mt	<b>83 st</b>	100 mt	<b>110 st</b>	85 mt	<b>94 st</b>
Cutter tip/tooth	110 mt	<b>121 st</b>	110 mt	<b>121 st</b>	110 mt	<b>121 st</b>	170 mt	<b>187 st</b>	160 mt	<b>176 st</b>
Primary cutter	225 mt	<b>248 st</b>	230 mt	<b>248 st</b>	250 mt	<b>248 st</b>	370 mt	<b>408 st</b>	300 mt	<b>331 st</b>
Jaw opening	685 mm	<b>26.96"</b>	740 mm	<b>29.13"</b>	820 mm	<b>32.28"</b>	350 mm	<b>13.77"</b>	470 mm	<b>18.50"</b>
Jaw depth	650 mm	<b>25.59"</b>	650 mm	<b>25.59"</b>	670 mm	<b>26.37"</b>	500 mm	<b>19.68"</b>	570 mm	<b>22.44"</b>
Cutting capacity:										
Narrow I-beams	<b>IPE300</b>		<b>N/A</b>		<b>N/A</b>		<b>IPE300</b>		<b>N/A</b>	
Wide I-beams	<b>HE-A200</b>		<b>N/A</b>		<b>N/A</b>		<b>HE-A200</b>		<b>N/A</b>	
Round bar	65 mm	<b>2.55"</b>	<b>N/A</b>		<b>N/A</b>		65 mm	<b>2.55"</b>	<b>N/A</b>	
Square bar	60 mm	<b>2.36"</b>	<b>N/A</b>		<b>N/A</b>		60 mm	<b>2.36"</b>	<b>N/A</b>	
Plate	<b>N/A</b>		<b>N/A</b>		<b>N/A</b>		219 x 8 mm	<b>8.62 x 0.31"</b>	<b>N/A</b>	
Crushing capacity:										
Concrete thickness	550 mm	<b>21.65"</b>	600 mm	<b>23.62"</b>	550 mm	<b>21.65"</b>	<b>N/A</b>		450 mm	<b>17.71"</b>

**Specifications** (All dimensions are approximate.)

<b>Jaw Type</b>	<b>MP324-CC</b>		<b>MP324-D</b>		<b>MP324-P</b>	
Housing weight, jaw	2610 kg	<b>5754 lb</b>	2640 kg	<b>5820 lb</b>	2740 kg	<b>6040 lb</b>
Weight of the jaw	1030 kg	<b>2270 lb</b>	1060 kg	<b>2327 lb</b>	1160 kg	<b>2327 lb</b>
Closing force:						
Tooth tip	105 mt	<b>116 st</b>	105 mt	<b>116 st</b>	105 mt	<b>116 st</b>
Cutter tip/tooth	150 mt	<b>165 st</b>	150 mt	<b>165 st</b>	150 mt	<b>165 st</b>
Primary cutter	320 mt	<b>353 st</b>	320 mt	<b>353 st</b>	340 mt	<b>353 st</b>
Jaw opening	830 mm	<b>32.67"</b>	905 mm	<b>35.62"</b>	970 mm	<b>38.18"</b>
Jaw depth	760 mm	<b>29.92"</b>	760 mm	<b>29.92"</b>	760 mm	<b>29.92"</b>
Cutting capacity:						
Narrow I-beams		<b>IPE400</b>		<b>N/A</b>		<b>N/A</b>
Wide I-beams		<b>HE-A260</b>		<b>N/A</b>		<b>N/A</b>
Round bar	80 mm	<b>3.14"</b>		<b>N/A</b>		<b>N/A</b>
Square bar	70 mm	<b>2.75"</b>		<b>N/A</b>		<b>N/A</b>
Crushing capacity:						
Concrete thickness	650 mm	<b>25.59"</b>	700 mm	<b>27.55"</b>	650 mm	<b>25.59"</b>

**Specifications** (All dimensions are approximate.)

<b>Jaw Type</b>	<b>MP324-S</b>		<b>MP324-U</b>		<b>MP324-TS</b>	
Housing weight, jaw	2530 kg	<b>5577 lb</b>	2690 kg	<b>5930 lb</b>	2740 kg	<b>6040 lb</b>
Weight of the jaw	940 kg	<b>2072 lb</b>	1100 kg	<b>2425 lb</b>	1130 kg	<b>2492 lb</b>
Closing force:						
Tooth tip	130 mt	<b>143 st</b>	115 mt	<b>127 st</b>	110 mt	<b>121 st</b>
Cutter tip/tooth	230 mt	<b>254 st</b>	160 mt	<b>176 st</b>	130 mt	<b>143 st</b>
Primary cutter	390 mt	<b>430 st</b>	350 mt	<b>386 st</b>	300 mt	<b>331 st</b>
Jaw opening	400 mm	<b>15.74"</b>	650 mm	<b>25.59"</b>	500 mm	<b>19.68"</b>
Jaw depth	620 mm	<b>24.40"</b>	680 mm	<b>26.77"</b>	490 mm	<b>19.29"</b>
Cutting capacity:						
Narrow I-beams		<b>IPE400</b>		<b>N/A</b>		<b>N/A</b>
Wide I-beams		<b>HE-A260</b>		<b>N/A</b>		<b>N/A</b>
Round bar	80 mm	<b>3.14"</b>		<b>N/A</b>		<b>N/A</b>
Square bar	70 mm	<b>2.75"</b>		<b>N/A</b>		<b>N/A</b>
Crushing capacity:						
Concrete thickness		<b>N/A</b>	600 mm	<b>23.62"</b>		<b>N/A</b>

**Specifications** (All dimensions are approximate.)

<b>Model</b>	<b>MP30</b>		<b>MP40</b>	
Weight total — housing, jaw and bracket	3890 kg	<b>8575 lb</b>	6430 kg	<b>14,175 lb</b>
Weight of the jaw	1300 kg	<b>2865 lb</b>	2200 kg	<b>4850 lb</b>
Dimensions:				
Length	2700 mm	<b>106.3"</b>	3400 mm	<b>133.9"</b>
Height	1680 mm	<b>66.1"</b>	1980 mm	<b>78"</b>
Width	1010 mm	<b>39.8"</b>	1180 mm	<b>46.5"</b>
Jaw width (fixed)	370 mm	<b>14.6"</b>	460 mm	<b>18.1"</b>
Jaw width (moving)	120 mm	<b>4.7"</b>	150 mm	<b>5.9"</b>
Jaw opening	470 mm	<b>18.5"</b>	630 mm	<b>24.8"</b>
Jaw depth	710 mm	<b>28"</b>	880 mm	<b>34.6"</b>
Cutter length	600 mm	<b>23.6"</b>	760 mm	<b>29.9"</b>
Maximum shear force:				
At tip	1600 kN	<b>180 st</b>	1900 kN	<b>213 st</b>
Primary blade center	3750 kN	<b>421 st</b>	4750 kN	<b>534 st</b>
At throat	7100 kN	<b>798 st</b>	8950 kN	<b>1006 st</b>
Maximum oil flow:				
Hydraulic cylinder	300 L/min	<b>79 gpm</b>	400 L/min	<b>106 gpm</b>
Cycle time (open, close, open)		<b>6.5 sec</b>		<b>7.5 sec</b>
Rotation	40 L/min	<b>11 gpm</b>	80 L/min	<b>22 gpm</b>
Maximum working pressure:				
Hydraulic cylinder	35 000 kPa	<b>5075 psi</b>	35 000 kPa	<b>5075 psi</b>
Rotation	14 000 kPa	<b>2030 psi</b>	14 000 kPa	<b>2030 psi</b>



**Specifications** (All dimensions are approximate.)

<b>Model</b>	<b>MP20</b>		<b>MP30</b>	
Weight total — housing, jaw and bracket	2740 kg	<b>6040 lb</b>	4380 kg	<b>9655 lb</b>
Weight of the jaw	1010 kg	<b>2225 lb</b>	1790 kg	<b>3945 lb</b>
Dimensions:				
Length	2400 mm	<b>94.5"</b>	2800 mm	<b>110.2"</b>
Height	1750 mm	<b>68.9"</b>	2100 mm	<b>82.7"</b>
Width	800 mm	<b>31.5"</b>	1180 mm	<b>46.5"</b>
Jaw width (fixed)	290 mm	<b>11.4"</b>	340 mm	<b>13.4"</b>
Jaw width (moving)	120 mm	<b>4.7"</b>	150 mm	<b>5.9"</b>
Jaw opening	440 mm	<b>17.3"</b>	510 mm	<b>20.1"</b>
Jaw depth	460 mm	<b>18.1"</b>	580 mm	<b>22.8"</b>
Cutter length	460 mm	<b>18.1"</b>	580 mm	<b>22.8"</b>
Maximum shear force:				
At tip	1400 kN	<b>157 st</b>	1900 kN	<b>213 st</b>
At jaw center	2200 kN	<b>247 st</b>	4000 kN	<b>449 st</b>
At throat	4400 kN	<b>494 st</b>	6350 kN	<b>714 st</b>
Cutting capacity plate steel	25 mm	<b>1"</b>	30 mm	<b>1.2"</b>
Maximum oil flow:				
Hydraulic cylinder	200 L/min	<b>53 gpm</b>	200 L/min	<b>53 gpm</b>
Cycle time (open, close, open)		<b>6 sec</b>		<b>6.5 sec</b>
Rotation	40 L/min	<b>11 gpm</b>	40 L/min	<b>11 gpm</b>
Maximum working pressure:				
Hydraulic cylinder	35 000 kPa	<b>5075 psi</b>	35 000 kPa	<b>5075 psi</b>
Rotation	14 000 kPa	<b>2030 psi</b>	14 000 kPa	<b>2030 psi</b>

**Specifications** (All dimensions are approximate.)

<b>Model</b>	<b>MP30</b>		<b>MP40</b>	
Weight total — housing, jaw and bracket	3860 kg	<b>8510 lb</b>	6370 kg	<b>14,045 lb</b>
Weight of the jaw	1270 kg	<b>2800 lb</b>	2230 kg	<b>4915 lb</b>
Dimensions:				
Length	2770 mm	<b>102"</b>	3500 mm	<b>137.8"</b>
Height	1980 mm	<b>78"</b>	2380 mm	<b>93.7"</b>
Width	1010 mm	<b>39.8"</b>	1180 mm	<b>46.5"</b>
Jaw width (fixed)	380 mm	<b>15"</b>	460 mm	<b>18.1"</b>
Jaw width (moving)	130 mm	<b>5.1"</b>	160 mm	<b>6.3"</b>
Jaw opening	1050 mm	<b>41.3"</b>	1320 mm	<b>52"</b>
Jaw depth	920 mm	<b>36.2"</b>	1100 mm	<b>43.3"</b>
Cutter length	260 mm	<b>10.2"</b>	250 mm	<b>9.8"</b>
Maximum crushing/shear force:				
Tooth — jaw tip	1250 kN	<b>140 st</b>	1500 kN	<b>168 st</b>
At 2 <sup>nd</sup> tooth	1750 kN	<b>197 st</b>	2200 kN	<b>247 st</b>
Primary blade center	3800 kN	<b>427 st</b>	4650 kN	<b>523 st</b>
Maximum oil flow:				
Hydraulic cylinder	300 L/min	<b>79 gpm</b>	400 L/min	<b>106 gpm</b>
Cycle time (open, close, open)		<b>6.5 sec</b>		<b>7.5 sec</b>
Rotation	40 L/min	<b>11 gpm</b>	80 L/min	<b>22 gpm</b>
Maximum working pressure:				
Hydraulic cylinder	35 000 kPa	<b>5075 psi</b>	35 000 kPa	<b>5075 psi</b>
Rotation	14 000 kPa	<b>2030 psi</b>	14 000 kPa	<b>2030 psi</b>

**Specifications** (All dimensions are approximate.)

<b>Model</b>	<b>MP30</b>	
Weight total — housing, jaw and bracket	4180 kg	<b>9215 lb</b>
Weight of the jaw	1590 kg	<b>3505 lb</b>
Dimensions:		
Length	2800 mm	<b>110.2"</b>
Height	1980 mm	<b>78"</b>
Width	1010 mm	<b>39.8"</b>
Jaw width (fixed)	610 mm	<b>24"</b>
Jaw width (moving)	370 mm	<b>14.6"</b>
Jaw opening	960 mm	<b>37.8"</b>
Jaw depth	940 mm	<b>37"</b>
Cutter length	250 mm	<b>9.8"</b>
Maximum crushing/shear force:		
Tooth — jaw tip	1250 kN	<b>140 st</b>
At 2 <sup>nd</sup> tooth	1550 kN	<b>174 st</b>
Primary blade center	3950 kN	<b>444 st</b>
Maximum oil flow:		
Hydraulic cylinder	300 L/min	<b>79 gpm</b>
Cycle time (open, close, open)	<b>6.5 sec</b>	
Rotation	40 L/min	<b>11 gpm</b>
Maximum working pressure:		
Hydraulic cylinder	35 000 kPa	<b>5075 psi</b>
Rotation	14 000 kPa	<b>2030 psi</b>

**Specifications** (All dimensions are approximate.)

<b>Model</b>	<b>MP30</b>		<b>MP40</b>	
Weight total — housing, jaw and bracket	4080 kg	<b>8995 lb</b>	6730 kg	<b>14,835 lb</b>
Weight of the jaw	1490 kg	<b>3285 lb</b>	2590 kg	<b>5710 lb</b>
Dimensions:				
Length	2950 mm	<b>116.1"</b>	3650 mm	<b>143.7"</b>
Height	2200 mm	<b>86.6"</b>	2550 mm	<b>100.4"</b>
Width	1010 mm	<b>39.8"</b>	1180 mm	<b>46.5"</b>
Jaw width (fixed)	580 mm	<b>22.8"</b>	700 mm	<b>27.6"</b>
Jaw width (moving)	420 mm	<b>16.5"</b>	480 mm	<b>18.9"</b>
Jaw opening	1100 mm	<b>43.3"</b>	1400 mm	<b>55.1"</b>
Jaw depth	970 mm	<b>38.2"</b>	1170 mm	<b>46"</b>
Cutter length	200 mm	<b>7.9"</b>	250 mm	<b>9.8"</b>
Maximum crushing/shear force:				
Tooth — jaw tip	1250 kN	<b>141 st</b>	1500 kN	<b>168 st</b>
At 2 <sup>nd</sup> tooth	1550 kN	<b>174 st</b>	1900 kN	<b>213 st</b>
Primary blade center	4800 kN	<b>539 st</b>	5500 kN	<b>618 st</b>
Maximum oil flow:				
Hydraulic cylinder	300 L/min	<b>79 gpm</b>	400 L/min	<b>106 gpm</b>
Cycle time (open, close, open)		<b>6.5 sec</b>		<b>7.5 sec</b>
Rotation	40 L/min	<b>11 gpm</b>	80 L/min	<b>22 gpm</b>
Maximum working pressure:				
Hydraulic cylinder	35 000 kPa	<b>5075 psi</b>	35 000 kPa	<b>5075 psi</b>
Rotation	14 000 kPa	<b>2030 psi</b>	14 000 kPa	<b>2030 psi</b>

**Cutting Capacity**

<b>Model</b>	<b>MP30</b>		<b>MP40</b>	
Narrow I-beams:				
Height	500 mm	<b>19.7"</b>	600 mm	<b>23.6"</b>
Flange width	200 mm	<b>7.9"</b>	600 mm	<b>8.7"</b>
Flange thickness	16 mm	<b>0.63"</b>	19 mm	<b>0.75"</b>
Web thickness	10.2 mm	<b>0.4"</b>	12 mm	<b>0.47"</b>
Wide I-beams:				
Height	310 mm	<b>12.2"</b>	390 mm	<b>15.4"</b>
Flange width	300 mm	<b>11.8"</b>	300 mm	<b>11.8"</b>
Flange thickness	15.5 mm	<b>0.61"</b>	19 mm	<b>0.75"</b>
Web thickness	9 mm	<b>0.35"</b>	11 mm	<b>0.43"</b>
Solid-round	90 mm	<b>3.5"</b>	100 mm	<b>3.9"</b>
Solid-square	80 mm	<b>3.1"</b>	90 mm	<b>3.5"</b>

The above profiles provide an indication of the shear's cutting capability. The exact cutting dimensions depend on excavator size, the conditions of the cutters and jaws and the tensile strength of the steel.

## CONTRACTOR'S GRAPPLES

### Features:

- Fits multiple linkages simply by changing the pin group.
- Designed with less curve allowing material to flow easily out of the grapple, simplifying material loading and unloading.
- Large wear areas made entirely of AR400 steel.
- Matches the entire range of small, medium and large excavators.
- Two-over-three tines interlock to securely grasp and retain more material when sorting and loading.
- Sized to match Cat machines making them able to better realize the machine's maximum performance; both break out and lift capacity.
- One grapple can be used with or without a coupler with no modifications.

### Applications:

Contractor's Grapples are built to handle demolition of brick and wood structures, land clearing, sorting and loading of rock, scrap, pipe, waste material and demolition debris.

### Guarding Recommendation

Contractor's Grapples used in hazardous applications like demolition, and scrap and material handling can create a need for special operator guarding due to flying or falling objects. When using a Contractor's Grapple, additional protective devices such as a front screen, Falling Object Guarding System (FOGS, includes top and front guarding), thick polycarbonate windshields or a combination of these is recommended by Caterpillar. Contact your Cat dealer for operator guarding options on your machine.

## Matching Guide

### Contractor's Grapples

Model	Cat Excavator
<b>G107B</b>	307 CR
<b>G112B</b>	312C
<b>G115B</b>	315C
<b>G120B</b>	320D 322C 324D 325D
<b>G125B</b>	320D 322C 324D 325D
<b>G130B</b>	320D 322C 324D 325D 330D
<b>G145B</b>	345C
<b>G165B</b>	345C 350 365C
<b>G185B</b>	385C

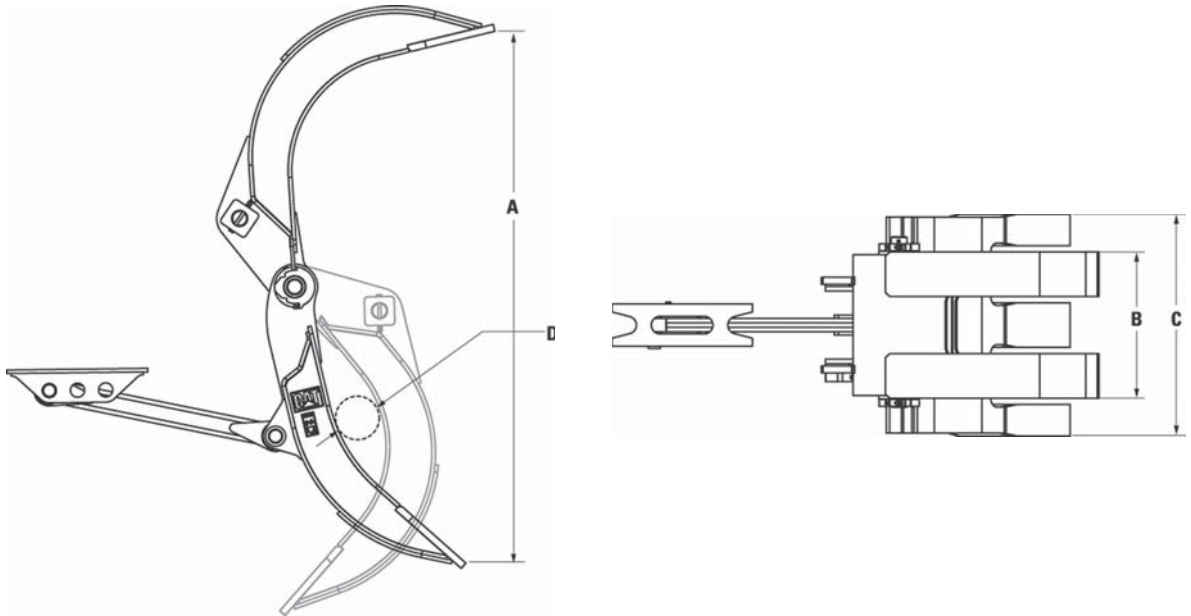

**Specifications** (All dimensions are approximate.)

Model	G107B		G112B		G115B		G120B		G125B	
Weight	360 kg	<b>794 lb</b>	857 kg	<b>1885 lb</b>	1286 kg	<b>2830 lb</b>	1523 kg	<b>3350 lb</b>	1932 kg	<b>4250 lb</b>
<b>A</b> Jaw Opening	1765 mm	<b>69.5"</b>	2195 mm	<b>86.4"</b>	2555 mm	<b>100.6"</b>	2687 mm	<b>105.8"</b>	3128 mm	<b>123.1"</b>
<b>B</b> Upper Tine Width	435 mm	<b>17.1"</b>	550 mm	<b>21.7"</b>	610 mm	<b>24"</b>	617 mm	<b>24.3"</b>	704 mm	<b>27.7"</b>
<b>C</b> Lower Tine Width	735 mm	<b>28.9"</b>	900 mm	<b>35.4"</b>	1020 mm	<b>40.2"</b>	1031 mm	<b>40.6"</b>	1150 mm	<b>45.3"</b>
<b>D</b> Minimum Opening	134 mm	<b>5.3"</b>	186 mm	<b>7.3"</b>	191 mm	<b>7.5"</b>	199 mm	<b>7.8"</b>	245 mm	<b>9.6"</b>
Inner Wrapper Thickness	8 mm	<b>0.3"</b>	12 mm	<b>0.5"</b>	12 mm	<b>0.5"</b>	16 mm	<b>0.6"</b>	16 mm	<b>0.6"</b>
Outer Wrapper Thickness	8 mm	<b>0.3"</b>	12 mm	<b>0.5"</b>	12 mm	<b>0.5"</b>	12 mm	<b>0.5"</b>	16 mm	<b>0.6"</b>
Wear Tip Thickness	12 mm	<b>0.5"</b>	20 mm	<b>0.8"</b>	25 mm	<b>1"</b>	30 mm	<b>1.2"</b>	40 mm	<b>1.6"</b>
Outer Wear Plate Thickness	12 mm	<b>0.5"</b>	16 mm	<b>0.6"</b>	25 mm	<b>1"</b>	20 mm	<b>0.8"</b>	20 mm	<b>0.8"</b>

Model	G130B		G145B		G165B		G185B	
Weight	2332 kg	<b>5130 lb</b>	3050 kg	<b>6724 lb</b>	4055 kg	<b>8940 lb</b>	4800 kg	<b>10,582 lb</b>
<b>A</b> Jaw Opening	3223 mm	<b>126.9"</b>	3433 mm	<b>135.2"</b>	3860 mm	<b>152"</b>	4076 mm	<b>160.5"</b>
<b>B</b> Upper Tine Width	832 mm	<b>32.8"</b>	865 mm	<b>34.1"</b>	937 mm	<b>36.9"</b>	985 mm	<b>38.8"</b>
<b>C</b> Lower Tine Width	1262 mm	<b>49.7"</b>	1335 mm	<b>52.6"</b>	1406 mm	<b>55.4"</b>	1535 mm	<b>60.4"</b>
<b>D</b> Minimum Opening	319 mm	<b>12.6"</b>	271 mm	<b>10.7"</b>	283 mm	<b>11.1"</b>	337 mm	<b>13.3"</b>
Inner Wrapper Thickness	20 mm	<b>0.8"</b>	20 mm	<b>0.8"</b>	25 mm	<b>1"</b>	25 mm	<b>1"</b>
Outer Wrapper Thickness	20 mm	<b>0.8"</b>	20 mm	<b>0.8"</b>	25 mm	<b>1"</b>	25 mm	<b>1"</b>
Wear Tip Thickness	40 mm	<b>1.6"</b>	40 mm	<b>1.6"</b>	40 mm	<b>1.6"</b>	40 mm	<b>1.6"</b>
Outer Wear Plate Thickness	20 mm	<b>0.8"</b>	25 mm	<b>1"</b>	30 mm	<b>1.2"</b>	30 mm	<b>1.2"</b>

**Features:**

- **360 Degree Rotation.** Slewing ring rotation system is proven and reliable.
- **Wide Jaw Opening** handles large objects and payloads.
- **Jaw Edges** are synchronized, always closing edge to edge in the center. Pick and sort even the smallest material.
- **Grapple Body and Jaws** are made from high-grade impact-resistant steel.
- **Reinforced Jaws** handle extreme use.
- **Outer Jaw Profile** is vertical when open for working against a wall or inside containers.

**Matching Guide**

Model	Cat Excavator
<b>G310B</b>	311-316
	M313-M316
<b>G315B</b>	318-321
	M315-M322
<b>G320B</b>	324-329
	330-385 UHD
	Apex 70-100
<b>G325B</b>	324-336
	330-385 UHD
	Apex 70-100
<b>G330</b>	329-349
	Apex 70-100



# Demolition and Sorting Grapples Americas North and South, Europe, Africa, Middle East

## Specifications

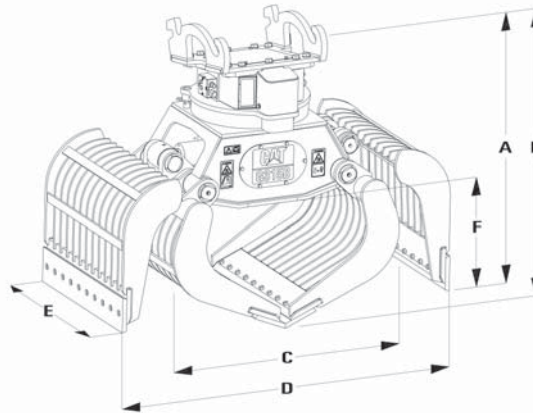

### Specifications (All dimensions are approximate.)

Model	G303 (Demolition/ Recycling)		G305 (Demolition/ Recycling)		G310B (Demolition)		G310B (Recycling**)	
	Capacity	140 L	<b>0.18 yd<sup>3</sup></b>	140 L	<b>0.18 yd<sup>3</sup></b>	375 L	<b>0.49 yd<sup>3</sup></b>	400 L
Weight*	420 kg	<b>926 lb</b>	420 kg	<b>926 lb</b>	1030 kg	<b>2270 lb</b>	985 kg	<b>2171 lb</b>
Dimensions:								
<b>A</b> Length	1160 mm	<b>45.6"</b>	1160 mm	<b>45.6"</b>	1350 mm	<b>53"</b>	1350 mm	<b>53"</b>
<b>B</b> Length	1040 mm	<b>41"</b>	1040 mm	<b>41"</b>	1440 mm	<b>57"</b>	1440 mm	<b>57"</b>
<b>C</b> Length	875 mm	<b>34.4"</b>	875 mm	<b>34.4"</b>	1245 mm	<b>49"</b>	1225 mm	<b>48"</b>
<b>D</b> Length	1650 mm	<b>65"</b>	1650 mm	<b>65"</b>	1800 mm	<b>71"</b>	1800 mm	<b>71"</b>
<b>E</b> Width	515 mm	<b>20.3"</b>	515 mm	<b>20.3"</b>	850 mm	<b>33"</b>	850 mm	<b>33"</b>
<b>F</b> Height	—	—	—	—	520 mm	<b>20"</b>	520 mm	<b>20"</b>
Closing force	15 kN	<b>3372 lbf</b>	15 kN	<b>3372 lbf</b>	36 kN	<b>8100 lbf</b>	36 kN	<b>8100 lbf</b>
Hydraulic for open/close:								
Maximum pressure	300 bar	<b>4351 psi</b>	300 bar	<b>4351 psi</b>	350 bar	<b>5076 psi</b>	350 bar	<b>5076 psi</b>
Maximum flow	40 L/min	<b>10.6 gpm</b>	40 L/min	<b>10.6 gpm</b>	60 L/min	<b>15.9 gpm</b>	60 L/min	<b>15.9 gpm</b>
Connection	—	—	—	—	-12	-12	-12	-12
Hydraulic for rotation:								
Maximum pressure	—	—	300 bar	<b>4351 psi</b>	350 bar	<b>5076 psi</b>	350 bar	<b>5076 psi</b>
Optimum flow	—	—	40 L/min	<b>10.6 gpm</b>	60 L/min	<b>15.9 gpm</b>	60 L/min	<b>15.9 gpm</b>
Connection	—	—	—	—	-8	-8	-8	-8
Excavator — class	3.5-6.5 mt	<b>3.9-7.2 st</b>	3.5-6.5 mt	<b>3.9-7.2 st</b>	9.1-14.5 mt	<b>10-16 st</b>	9.1-14.5 mt	<b>10-16 st</b>

\*Weights exclude standard Quick Coupler mounting brackets.

\*\*Not available in the Americas.

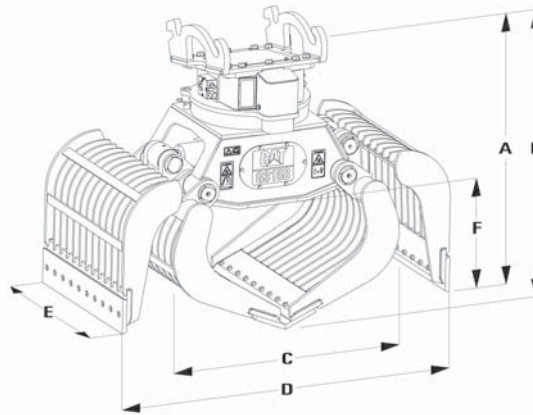

**Specifications** (All dimensions are approximate.)

Model	G315B (Demolition)		G315B (Recycling**)		G320B (Demolition)	
	Capacity	550 L	1.3 yd <sup>3</sup>	600 L	0.78 yd <sup>3</sup>	750 L
Weight*	1400 kg	3086 lb	1350 kg	2976 lb	1875 kg	4133 lb
Dimensions:						
<b>A</b> Length	1455 mm	57"	1455 mm	57"	1630 mm	64"
<b>B</b> Length	1550 mm	61"	1550 mm	61"	1725 mm	68"
<b>C</b> Length	1375 mm	54"	1360 mm	54"	1540 mm	61"
<b>D</b> Length	2000 mm	79"	2000 mm	79"	2200 mm	87"
<b>E</b> Width	1000 mm	39"	1000 mm	39"	1100 mm	43"
<b>F</b> Height	570 mm	22"	570 mm	22"	625 mm	25"
Closing force	52 kN	11,700 lbf	52 kN	11,700 lbf	66 kN	14,850 lbf
Hydraulic for open/close:						
Maximum pressure	350 bar	5076 psi	350 bar	5076 psi	350 bar	5076 psi
Maximum flow	90 L/min	23.8 gpm	90 L/min	23.8 gpm	120 L/min	31.7 gpm
Connection		-12		-12		-16
Hydraulic for rotation:						
Maximum pressure	140 bar	2030 psi	140 bar	2030 psi	140 bar	2030 psi
Optimum flow	40 L/min	10.6 gpm	40 L/min	10.6 gpm	40 L/min	10.6 gpm
Connection		-8		-8		-8
Excavator — class	13.6-20.0 mt	15-22 st	13.6-20.0 mt	15-22 st	18.1-26.3 mt	20-29 st

\*Weights exclude standard Quick Coupler mounting brackets. Also available with fixed upperhead version.

\*\*Not available in the Americas.

Model	G315BWH (Waste Handling)		G315B	
Width	1100 mm	43.3"	1000 mm	39.4"
Opening	2200 mm	86.6"	2000 mm	78.7"
Tip force	49.5 kN	11,128 lbf	52 kN	11,690 lbf
BOCE		G320B		G315B
Weight	1450 kg	3190 lb	1405 kg	3091 lb
Volume	800 L	1.0 yd <sup>3</sup>	600 L	0.8 yd <sup>3</sup>

Matching: M318, M322, 319, 320, 321 and 323.

**Demolition and  
Sorting Grapples  
Americas North and South,  
Europe, Africa, Middle East**

**Specifications**

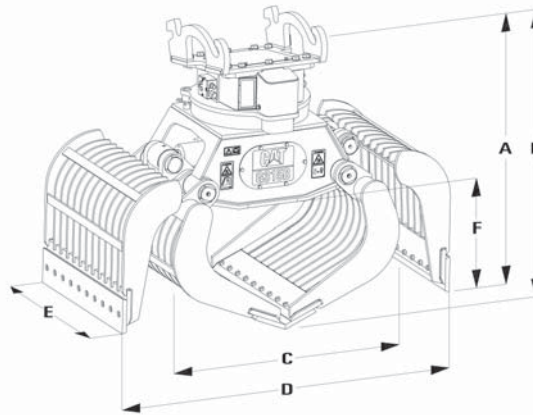

**Specifications** (All dimensions are approximate.)

Model	G320B (Recycling**)		G325B (Demolition)		G325B (Recycling**)	
	Capacity	800 L	1.05 yd <sup>3</sup>	900 L	1.18 yd <sup>3</sup>	900 L
Weight*	1820 kg	4012 lb	2040 kg	4497 lb	2090 kg	4607 lb
Dimensions:						
<b>A</b> Length	1630 mm	64"	1630 mm	64"	1630 mm	64"
<b>B</b> Length	1725 mm	68"	1725 mm	68"	1725 mm	68"
<b>C</b> Length	1505 mm	59"	1540 mm	61"	1540 mm	61"
<b>D</b> Length	2200 mm	87"	2200 mm	87"	2200 mm	87"
<b>E</b> Width	1100 mm	43"	1350 mm	53"	1350 mm	53"
<b>F</b> Height	625 mm	25"	625 mm	25"	625 mm	25"
Closing force	66 kN	14,850 lbf	66 kN	14,850 lbf	66 kN	14,850 lbf
Hydraulic for open/close:						
Maximum pressure	350 bar	5076 psi	350 bar	5076 psi	350 bar	5076 psi
Maximum flow	120 L/min	31.7 gpm	120 L/min	31.7 gpm	120 L/min	31.7 gpm
Connection		-16		-16		-16
Hydraulic for rotation:						
Maximum pressure	140 bar	2030 psi	140 bar	2030 psi	140 bar	2030 psi
Optimum flow	40 L/min	10.6 gpm	40 L/min	10.6 gpm	40 L/min	10.6 gpm
Connection		-8		-8		-8
Excavator — class	18.1-26.3 mt	20-29 st	25-38 mt	27.5-41.8 st	25-38 mt	27.5-41.8 st

\*Weights exclude standard Quick Coupler mounting brackets. G320B is also available with fixed upperhead version.

\*\*Not available in the Americas.

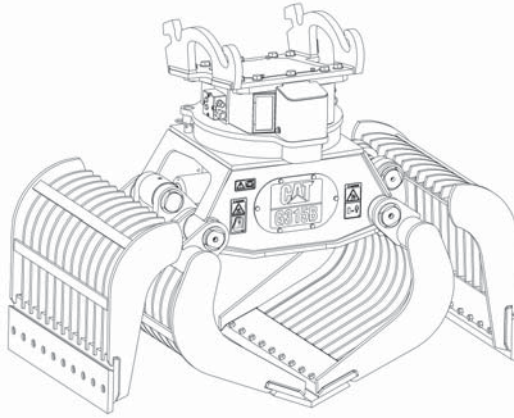
**Specifications** (All dimensions are approximate.)

Model	Fixed Upper Head					
	G310 GC		G313 GC		G315 GC	
Operating weight	865 kg	<b>1903 lb</b>	895 kg	<b>1969 lb</b>	1200 kg	<b>2640 lb</b>
Height open	1272 mm	<b>50"</b>	1272 mm	<b>50"</b>	1365 mm	<b>54"</b>
Height closed	1365 mm	<b>54"</b>	1365 mm	<b>54"</b>	1475 mm	<b>58"</b>
Shell width	850 mm	<b>33"</b>	950 mm	<b>37"</b>	1000 mm	<b>39"</b>
Capacity	400 L	<b>0.52 yd<sup>3</sup></b>	450 L	<b>0.59 yd<sup>3</sup></b>	600 L	<b>0.78 yd<sup>3</sup></b>
Operating maximum pressure						
Open/closing	35 000 kPa	<b>5076 psi</b>	35 000 kPa	<b>5076 psi</b>	35 000 kPa	<b>5076 psi</b>
Rotation	22 000 kPa	<b>3191 psi</b>	22 000 kPa	<b>3191 psi</b>	22 000 kPa	<b>3191 psi</b>
Operating flow						
Open/closing	60 L/min	<b>16 gpm</b>	60 L/min	<b>16 gpm</b>	90 L/min	<b>24 gpm</b>
Rotation	40 L/min	<b>11 gpm</b>	40 L/min	<b>11 gpm</b>	40 L/min	<b>11 gpm</b>
Closing force	36 kN	<b>8093 lbf</b>	36 kN	<b>8093 lbf</b>	52 kN	<b>11,690 lbf</b>

**Demolition and  
Sorting Grapples  
Americas North and South,  
Europe, Africa, Middle East**

**Specifications**

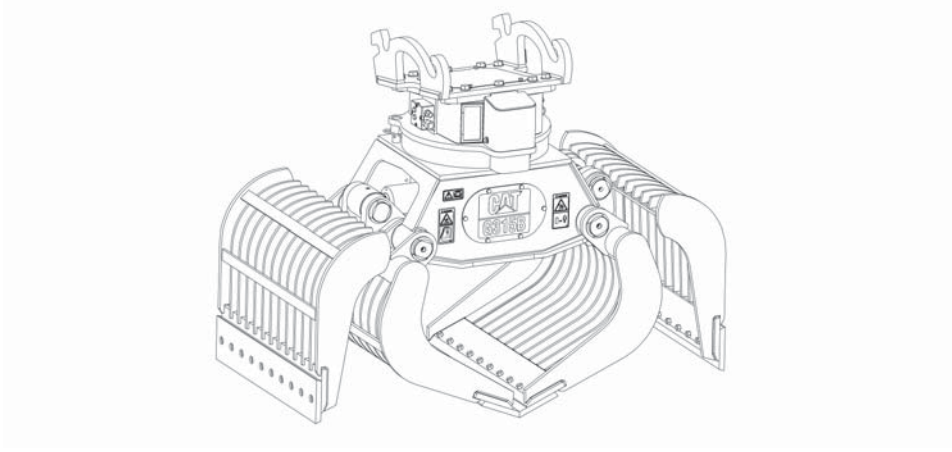

**Specifications** (All dimensions are approximate.)

Model	Flat Top Upper Head					
	G310 GC		G313 GC		G315 GC	
Operating weight	814 kg	<b>1791 lb</b>	845 kg	<b>1859 lb</b>	1142 kg	<b>2512 lb</b>
Height open	1223 mm	<b>48"</b>	1223 mm	<b>48"</b>	1326 mm	<b>52"</b>
Height closed	1315 mm	<b>52"</b>	1315 mm	<b>52"</b>	1427 mm	<b>56"</b>
Shell width	850 mm	<b>33"</b>	950 mm	<b>37"</b>	1000 mm	<b>39"</b>
Capacity	400 L	<b>0.52 yd<sup>3</sup></b>	450 L	<b>0.59 yd<sup>3</sup></b>	600 L	<b>0.78 yd<sup>3</sup></b>
Operating maximum pressure						
Open/closing	35 000 kPa	<b>5076 psi</b>	35 000 kPa	<b>5076 psi</b>	35 000 kPa	<b>5076 psi</b>
Rotation	22 000 kPa	<b>3191 psi</b>	22 000 kPa	<b>3191 psi</b>	22 000 kPa	<b>3191 psi</b>
Operating flow						
Open/closing	60 L/min	<b>16 gpm</b>	60 L/min	<b>16 gpm</b>	90 L/min	<b>24 gpm</b>
Rotation	40 L/min	<b>11 gpm</b>	40 L/min	<b>11 gpm</b>	40 L/min	<b>11 gpm</b>
Closing force	36 kN	<b>8093 lbf</b>	36 kN	<b>8093 lbf</b>	52 kN	<b>11,690 lbf</b>

**Features:**

- Continuous, bi-directional 360° hydraulic rotation.
- Heavy-duty, fully protected cylinders.
- Tines constructed of high-strength wear-resistant steel.

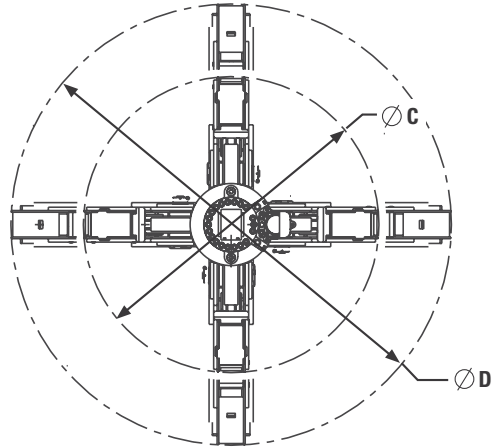
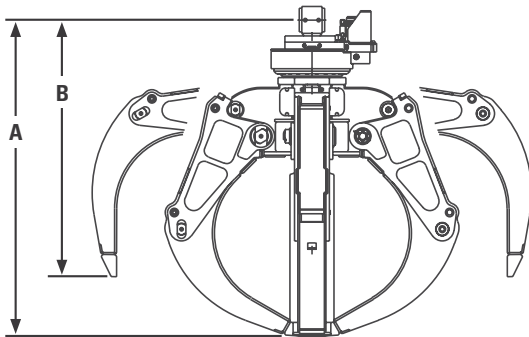

Model		GSH15B	GSH20B		GSH22B		
Part number		293-3202	292-6768	292-7730	292-7743	259-9691	259-9704
Industry capacity class	L (yd <sup>3</sup> )	600 (0.75)	600 (0.75)	800 (1.00)	1000 (1.25)	1000 (1.50)	1500 (2.00)
Operating weight	kg (lb)	1215 (2679)	1575 (3472)	1615 (3560)	1660 (3660)	2390 (5269)	2410 (5313)
Maximum lift capacity	kg (lb)	4000 (8818)	8000 (17,637)	8000 (17,637)	8000 (17,637)	12 000 (26,455)	12 000 (26,455)
<b>Dimensions</b>							
<b>A</b> Height — tines closed*	mm (in)	1740 (68.50)	1720 (67.72)	1860 (73.23)	2010 (79.13)	2175 (85.63)	2265 (89.17)
<b>B</b> Height — tines open*	mm (in)	1385 (54.53)	1440 (56.69)	1510 (59.45)	1590 (62.60)	1830 (72.05)	1880 (72.36)
<b>C</b> Diameter — tines closed	mm (in)	1540 (60.63)	1735 (68.31)	1735 (68.31)	1735 (68.31)	2050 (80.71)	2050 (80.71)
<b>D</b> Diameter — tines open	mm (in)	2415 (95.08)	2390 (94.09)	2595 (101.97)	2855 (102.40)	2950 (116.14)	3050 (120.08)

\*Includes hydraulic rotator, excludes machine link.

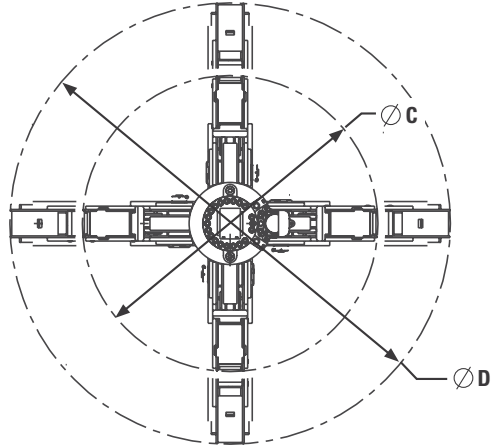
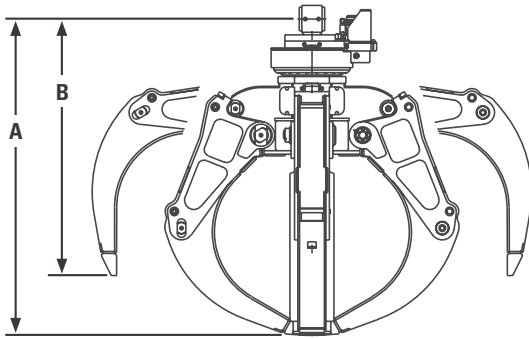

Model		GSH15B	GSH20B		GSH22B		
Part number		293-3202	292-6768	292-7730	292-7743	259-9691	259-9704
<b>Dimensions</b>							
Ground clearance — tines open	mm (in)	640 (25.20)	645 (25.40)	715 (28.15)	790 (31.10)	900 (35.43)	955 (37.60)
Pin diameter	mm (in)	70 (2.76)	80 (3.15)	80 (3.15)	80 (3.15)	90 (3.54)	90 (3.54)
Width of crosshead	mm (in)	114 (4.49)	150 (5.91)	150 (5.91)	150 (5.91)	200 (7.87)	200 (7.87)
Overall width	mm (in)	1810 (71.26)	1800 (70.87)	1930 (75.98)	2125 (83.66)	2230 (87.80)	2320 (91.34)
Maximum opening	mm (in)	2121 (83.50)	2064 (81.26)	2305 (90.75)	2552 (100.47)	2522 (99.29)	2675 (105.31)
<b>Hydraulic Open/Close</b>							
Maximum pressure	bar (psi)	350 (5076)	350 (5076)	350 (5076)	350 (5076)	350 (5076)	350 (5076)
Optimum flow	L/min (gpm)	100 (26.42)	150 (39.63)	150 (39.63)	150 (39.63)	200 (52.83)	200 (52.83)
<b>Hydraulic Rotation</b>							
Maximum pressure	bar (psi)	180 (2610)	200 (2900)	200 (2900)	200 (2900)	200 (2900)	200 (2900)
Optimum pressure	bar (psi)	140 (2030)	160 (2320)	160 (2320)	160 (2320)	160 (2320)	160 (2320)
Optimum flow	L/min (gpm)	20 (5.28)	20 (5.28)	20 (5.28)	20 (5.28)	20 (5.28)	20 (5.28)

Matching Guide

	Boom Length		Stick Length		GSH15B	GSH20B			GSH22B	
	m	(ft/in)	m	(ft/in)	0.57 m <sup>3</sup> (0.75 yd <sup>3</sup> )	0.57 m <sup>3</sup> (0.75 yd <sup>3</sup> )	0.76 m <sup>3</sup> (1.00 yd <sup>3</sup> )	0.96 m <sup>3</sup> (1.25 yd <sup>3</sup> )	1.15 m <sup>3</sup> (1.50 yd <sup>3</sup> )	1.53 m <sup>3</sup> (2.00 yd <sup>3</sup> )
<b>M318C MH</b>	6.2	(20'3")	4.9	(16'1")	X					
<b>M318D MH</b>	6.2	(20'3")	4.9	(16'1")	X					
<b>M322C MH</b>	6.8	(22'3")	4.9	(16'1")	X	+	+	+		
			5.9	(19'4")	-	-	X			
<b>M322D MH</b>	6.8	(22'4")	4.9	(16'1")	X	+	+	+		
			5.9	(19'4")	-	-	X			
<b>M325C MH</b>	8.9	(29'0")	6.0	(19'8")		-	X	+		
			7.4	(24'4")		X				
<b>M325C L MH</b>	8.9	(29'0")	6.0	(19'8")		-	X	+		
			7.4	(24'4")		-	X			
<b>M325D MH</b>	8.9	(29'0")	6.0	(19'8")		-	X	+		
			7.4	(24'4")		X				
<b>M325D L MH</b>	8.9	(29'0")	6.0	(19'8")		-	-	X	+	
			7.4	(24'4")		-	X			
<b>320C MH</b>	6.7	(21'10")	5.5	(17'11")	X					
<b>325C MH</b>	8.4	(27'5")	5.5	(17'11")		-	X			
	8.85	(29'0")	6.0	(19'8")		X				
<b>325D MH</b>	8.85	(29'0")	6.0	(19'8")		-	X			
			7.4	(24'4")		X				
<b>330C MH</b>	9.1	(29'10")	6.0	(19'8")		-	X			
<b>330D MH</b>	9.2	(30'2")	6.1	(20'0")		-	-	-	X	
			7.6	(24'11")		-	-	X		
<b>W345C MH</b>	9.9	(32'6")	7.4	(24'4")					-	X
			9.1	(29'10")					-	X
<b>345C MH</b>	9.9	(32'6")	7.4	(24'4")					-	X
			9.1	(29'10")					X	

- X Primary match for good stability in average scrap handling situations. Considers a material density in the 1200 kg/m<sup>3</sup> (2000 lb/yd<sup>3</sup>) range.
- + Secondary match for **less** dense material.
- Secondary match for **more** dense material.

Guarding Recommendation

Orange Peel Grapples used in hazardous applications like scrap and material handling can create a need for special operator guarding due to flying objects. When using an Orange Peel Grapple, additional protective

devices such as a front screen, Falling Object Guarding System (FOGS, includes top and front guarding), thick polycarbonate windshields or a combination of these is recommended by Caterpillar. Contact your Cat dealer for operator guarding options on your machine.



**Features:**

- Suitable for a wide range of applications.
- Maximum component protection; lower operating cost.
- Low profile.
- High stability.
- Protected hydraulics.
- Connection lines protection guard.
- Tines constructed of high-strength wear resistant steel.
- Continuous, bi-directional 360° hydraulic rotator.
- Pressure limiting valve for opening and closing.
- Heavy-duty, cushioned cylinders with swing bearings on both sides.
- Maintenance covers for easy access to all maintenance points.
- Weld-on replaceable tips.
- High commonality of parts between 5 and 4 tine configurations.
- Hardened steel-alloy pins.
- High closing force.
- Excellent material penetration.
- Superior lifting capacity.

**Selection by Application**

Grapple Application		4 Tines				5 Tines			
		O	S	C	N	O	S	C	N
<b>Handling Scrap, Iron and Steel</b>	Small-sized pieces (shredded)	x				x			
	Large-sized pieces up to 1000 × 1000 mm (39" × 39") (steel scrap, wrought iron, white goods, motor blocks)								
	Heavy/long-sized pieces (I-beams, pipes, plates)			x				x	
	Car bodies			x				x	
<b>Handling Nonferrous Scrap Metals</b>	Small-sized pieces (beverage cans, electric devices)	x				x			
	Large-sized pieces (car radiators, batteries)								
	Wires and cables (copper, lead)								
<b>Other Nonferrous Materials</b>	Waste								
	Rocks, concrete blocks			x				x	

Very good  
  Good  
 x Not Recommended  
 O Open  
 S Semi-closed  
 C Closed  
 N Narrow

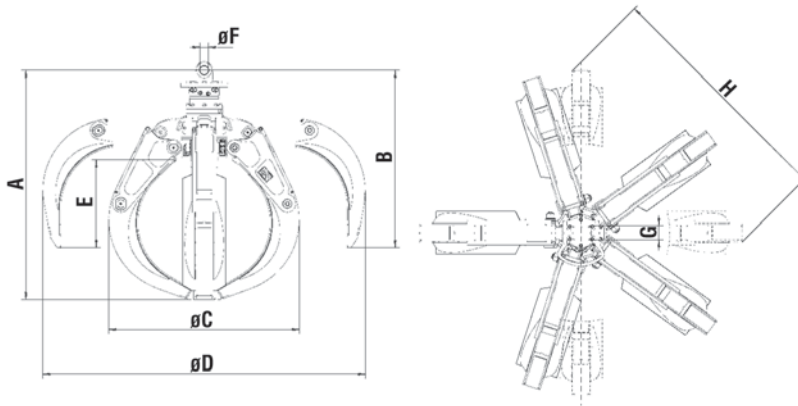

**Specifications** (All dimensions and weights are approximate.)

<b>Model</b>	<b>GSH15B</b>		<b>GSH15B</b>		<b>GSH15B</b>		<b>GSH15B</b>	
Type	400		500		600		800	
Recommended carrier weight:								
Excavator	15-21 mt	<b>16.5-23.1 st</b>	15-21 mt	<b>16.5-23.1 st</b>	15-21 mt	<b>16.5-23.1 st</b>	15-21 mt	<b>16.5-23.1 st</b>
Material Handler	18-25 mt	<b>19.8-27.6 st</b>	18-25 mt	<b>19.8-27.6 st</b>	18-25 mt	<b>19.8-27.6 st</b>	18-25 mt	<b>19.8-27.6 st</b>
Capacity	0.4 m <sup>3</sup>	<b>1.0 yd<sup>3</sup></b>	0.5 m <sup>3</sup>	<b>1.0 yd<sup>3</sup></b>	0.6 m <sup>3</sup>	<b>0.75 yd<sup>3</sup></b>	0.8 m <sup>3</sup>	<b>1.0 yd<sup>3</sup></b>
<b>5 Tines</b>								
Operating weight:								
open	1375 kg	<b>3027 lb</b>	1380 kg	<b>3043 lb</b>	1395 kg	<b>3076 lb</b>	1465 kg	<b>3230 lb</b>
semi-closed	1445 kg	<b>3186 lb</b>	1455 kg	<b>3208 lb</b>	1475 kg	<b>3252 lb</b>	1545 kg	<b>3407 lb</b>
closed	1530 kg	<b>3374 lb</b>	1540 kg	<b>3411 lb</b>	1575 kg	<b>3473 lb</b>	1655 kg	<b>3655 lb</b>
narrow	—	—	—	—	1450 kg	<b>3386 lb</b>	1515 kg	<b>3341 lb</b>
<b>4 Tines</b>								
Operating weight:								
open	1155 kg	<b>2538 lb</b>	1160 kg	<b>2558 lb</b>	1175 kg	<b>2591 lb</b>	1210 kg	<b>2668 lb</b>
semi-closed	1225 kg	<b>2701 lb</b>	1235 kg	<b>2723 lb</b>	1250 kg	<b>2756 lb</b>	1300 kg	<b>2867 lb</b>
closed	1355 kg	<b>2988 lb</b>	1375 kg	<b>3032 lb</b>	1410 kg	<b>3109 lb</b>	1495 kg	<b>3296 lb</b>
narrow	—	—	—	—	1215 kg	<b>2679 lb</b>	1260 kg	<b>2778 lb</b>
Dimensions:								
<b>A</b>	1670 mm	<b>66"</b>	1700 mm	<b>67"</b>	1760 mm	<b>69"</b>	1890 mm	<b>74"</b>
<b>B</b>	1350 mm	<b>53"</b>	1370 mm	<b>54"</b>	1400 mm	<b>55"</b>	1460 mm	<b>57"</b>
<b>C</b>	1500 mm	<b>59"</b>	1500 mm	<b>59"</b>	1500 mm	<b>59"</b>	1500 mm	<b>59"</b>
<b>D</b>	2190 mm	<b>86"</b>	2250 mm	<b>89"</b>	2340 mm	<b>92"</b>	2550 mm	<b>100"</b>
<b>E</b>	600 mm	<b>24"</b>	620 mm	<b>24"</b>	650 mm	<b>26"</b>	710 mm	<b>28"</b>
<b>F</b>	70 mm	<b>3"</b>	70 mm	<b>3"</b>	70 mm	<b>3"</b>	70 mm	<b>3"</b>
<b>G</b>	114 mm	<b>4"</b>	114 mm	<b>4"</b>	114 mm	<b>4"</b>	114 mm	<b>4"</b>
<b>H</b>	1440 mm	<b>57"</b>	1480 mm	<b>58"</b>	1540 mm	<b>57"</b>	1670 mm	<b>66"</b>
<b>I</b>	2085 mm	<b>82"</b>	2145 mm	<b>84"</b>	2230 mm	<b>88"</b>	2430 mm	<b>96"</b>
<b>H (4 tines)</b>	1700 mm	<b>67"</b>	1740 mm	<b>69"</b>	1810 mm	<b>71"</b>	1970 mm	<b>78"</b>
Hydraulic open/close:								
Maximum pressure	350 bar	<b>5075 psi</b>	350 bar	<b>5075 psi</b>	350 bar	<b>5075 psi</b>	350 bar	<b>5075 psi</b>
Optimum flow	100 L/min	<b>26 gpm</b>	100 L/min	<b>26 gpm</b>	100 L/min	<b>26 gpm</b>	100 L/min	<b>26 gpm</b>
Hydraulic rotation:								
Maximum pressure	140 bar	<b>2030 psi</b>	140 bar	<b>2030 psi</b>	140 bar	<b>2030 psi</b>	140 bar	<b>2030 psi</b>
Optimum flow	20 L/min	<b>5 gpm</b>	20 L/min	<b>5 gpm</b>	20 L/min	<b>5 gpm</b>	20 L/min	<b>5 gpm</b>

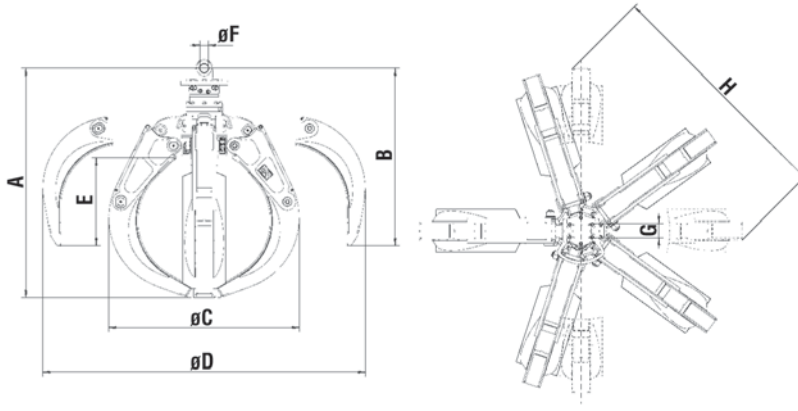

**Specifications** (All dimensions and weights are approximate.)

<b>Model</b>	<b>GSH20B</b>		<b>GSH20B</b>		<b>GSH20B</b>	
Type	<b>600</b>		<b>800</b>		<b>1000</b>	
Recommended carrier weight:						
Excavator	20-30 mt	<b>22-33.1 st</b>	20-30 mt	<b>22-33.1 st</b>	20-30 mt	<b>22-33.1 st</b>
Material Handler	25-35 mt	<b>27.6-49.6 st</b>	25-35 mt	<b>27.6-49.6 st</b>	25-35 mt	<b>27.6-49.6 st</b>
Capacity	0.6 m <sup>3</sup>	<b>0.75 yd<sup>3</sup></b>	0.8 m <sup>3</sup>	<b>1.0 yd<sup>3</sup></b>	1.0 m <sup>3</sup>	<b>1.25 yd<sup>3</sup></b>
<b>5 Tines</b>						
Operating weight:						
open	1820 kg	<b>4013 lb</b>	1855 kg	<b>4090 lb</b>	1900 kg	<b>4190 lb</b>
semi-closed	1905 kg	<b>4201 lb</b>	1955 kg	<b>4311 lb</b>	2020 kg	<b>4454 lb</b>
closed	1985 kg	<b>4377 lb</b>	2055 kg	<b>4531 lb</b>	2145 kg	<b>4730 lb</b>
narrow	1870 kg	<b>4123 lb</b>	1920 kg	<b>4234 lb</b>	1975 kg	<b>4355 lb</b>
<b>4 Tines</b>						
Operating weight:						
open	1545 kg	<b>3407 lb</b>	1570 kg	<b>3462 lb</b>	1605 kg	<b>3539 lb</b>
semi-closed	1615 kg	<b>3561 lb</b>	1655 kg	<b>3649 lb</b>	1705 kg	<b>3760 lb</b>
closed	1745 kg	<b>3848 lb</b>	1820 kg	<b>4013 lb</b>	1910 kg	<b>4212 lb</b>
narrow	1575 kg	<b>3473 lb</b>	1615 kg	<b>3561 lb</b>	1660 kg	<b>3660 lb</b>
Dimensions:						
<b>A</b>	1720 mm	<b>68"</b>	1860 mm	<b>73"</b>	2010 mm	<b>79"</b>
<b>B</b>	1440 mm	<b>57"</b>	1510 mm	<b>59"</b>	1590 mm	<b>63"</b>
<b>C</b>	1735 mm	<b>68"</b>	1735 mm	<b>68"</b>	1735 mm	<b>68"</b>
<b>D</b>	2390 mm	<b>94"</b>	2595 mm	<b>102"</b>	2855 mm	<b>112"</b>
<b>E</b>	645 mm	<b>25"</b>	715 mm	<b>28"</b>	790 mm	<b>31"</b>
<b>F</b>	80 mm	<b>3"</b>	80 mm	<b>3"</b>	80 mm	<b>3"</b>
<b>G</b>	150 mm	<b>6"</b>	150 mm	<b>6"</b>	150 mm	<b>6"</b>
<b>H</b>	1530 mm	<b>60"</b>	1640 mm	<b>65"</b>	1800 mm	<b>71"</b>
<b>I</b>	2210 mm	<b>87"</b>	2395 mm	<b>94"</b>	2635 mm	<b>104"</b>
<b>H (4 tines)</b>	1800 mm	<b>71"</b>	1930 mm	<b>76"</b>	2125 mm	<b>84"</b>
Hydraulic open/close:						
Maximum pressure	350 bar	<b>5075 psi</b>	350 bar	<b>5075 psi</b>	350 bar	<b>5075 psi</b>
Optimum flow	150 L/min	<b>40 gpm</b>	150 L/min	<b>40 gpm</b>	150 L/min	<b>40 gpm</b>
Hydraulic rotation:						
Maximum pressure	200 bar	<b>2900 psi</b>	200 bar	<b>2900 psi</b>	200 bar	<b>2900 psi</b>
Optimum flow	20 L/min	<b>5 gpm</b>	20 L/min	<b>5 gpm</b>	20 L/min	<b>5 gpm</b>

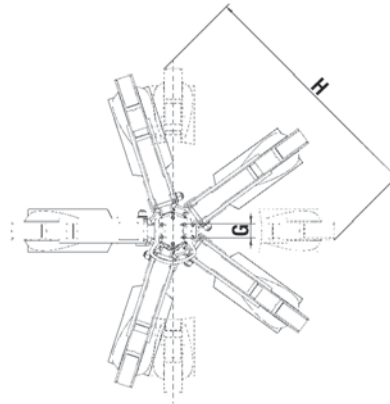
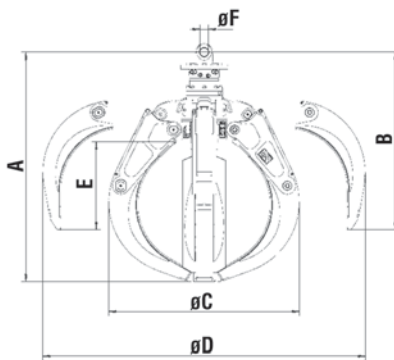

**Specifications** (All dimensions and weights are approximate.)

Model	GSH22B 600		GSH22B 800		GSH22B 1000	
Type						
Recommended carrier weight:						
Excavator	22-50 mt	<b>24.3-55.1 st</b>	22-50 mt	<b>24.3-55.1 st</b>	22-50 mt	<b>24.3-55.1 st</b>
Material Handler	35-60 mt	<b>38.6-66.1 st</b>	35-60 mt	<b>38.6-66.1 st</b>	35-60 mt	<b>38.6-66.1 st</b>
Capacity	0.6 m <sup>3</sup>	<b>0.75 yd<sup>3</sup></b>	0.8 m <sup>3</sup>	<b>1.0 yd<sup>3</sup></b>	1.0 m <sup>3</sup>	<b>1.25 yd<sup>3</sup></b>
<b>5 Tines</b>						
Operating weight:						
open	2660 kg	<b>5865 lb</b>	2715 kg	<b>4796 lb</b>	2740 kg	<b>6042 lb</b>
semi-closed	2770 kg	<b>6108 lb</b>	2855 kg	<b>6295 lb</b>	2890 kg	<b>6372 lb</b>
closed	2860 kg	<b>6306 lb</b>	2980 kg	<b>6571 lb</b>	3030 kg	<b>6681 lb</b>
narrow	—	—	—	—	2855 kg	<b>6295 lb</b>
<b>4 Tines</b>						
Operating weight:						
open	2255 kg	<b>4972 lb</b>	2295 kg	<b>5060 lb</b>	2315 kg	<b>5105 lb</b>
semi-closed	2350 kg	<b>5182 lb</b>	2415 kg	<b>5325 lb</b>	2440 kg	<b>5380 lb</b>
closed	2530 kg	<b>5696 lb</b>	2650 kg	<b>5843 lb</b>	2700 kg	<b>5954 lb</b>
narrow	—	—	—	—	2390 kg	<b>5270 lb</b>
Dimensions:						
<b>A</b>	1970 mm	<b>70"</b>	2100 mm	<b>83"</b>	2175 mm	<b>86"</b>
<b>B</b>	1710 mm	<b>67"</b>	1785 mm	<b>70"</b>	1830 mm	<b>72"</b>
<b>C</b>	2050 mm	<b>81"</b>	2050 mm	<b>81"</b>	2050 mm	<b>81"</b>
<b>D</b>	2640 mm	<b>104"</b>	2840 mm	<b>112"</b>	2950 mm	<b>116"</b>
<b>E</b>	780 mm	<b>31"</b>	860 mm	<b>34"</b>	900 mm	<b>35"</b>
<b>F</b>	90 mm	<b>4"</b>	90 mm	<b>4"</b>	90 mm	<b>4"</b>
<b>G</b>	200 mm	<b>8"</b>	200 mm	<b>8"</b>	200 mm	<b>8"</b>
<b>H</b>	1530 mm	<b>60"</b>	1840 mm	<b>72"</b>	1900 mm	<b>75"</b>
<b>I</b>	2450 mm	<b>96"</b>	2635 mm	<b>104"</b>	2730 mm	<b>107"</b>
<b>H (4 tines)</b>	2010 mm	<b>79"</b>	2160 mm	<b>85"</b>	2230 mm	<b>88"</b>
Hydraulic open/close:						
Maximum pressure	350 bar	<b>5075 psi</b>	350 bar	<b>5075 psi</b>	350 bar	<b>5075 psi</b>
Optimum flow	200 L/min	<b>53 gpm</b>	200 L/min	<b>53 gpm</b>	200 L/min	<b>53 gpm</b>
Hydraulic rotation:						
Maximum pressure	200 bar	<b>2900 psi</b>	200 bar	<b>2900 psi</b>	200 bar	<b>2900 psi</b>
Optimum flow	20 L/min	<b>5 gpm</b>	20 L/min	<b>5 gpm</b>	20 L/min	<b>5 gpm</b>

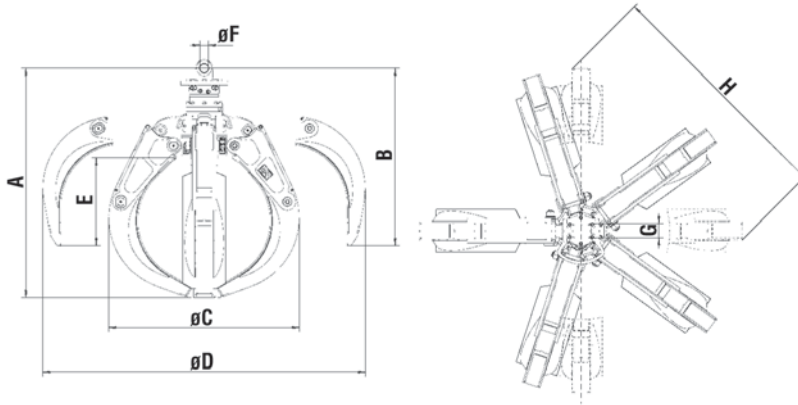

**Specifications** (All dimensions and weights are approximate.)

<b>Model</b>	<b>GSH22B</b>		<b>GSH22B</b>	
Type	<b>1250</b>		<b>1500</b>	
Recommended carrier weight:				
Excavator	22-50 mt	<b>24.3-55.1 st</b>	22-50 mt	<b>24.3-55.1 st</b>
Material Handler	35-60 mt	<b>38.6-66.1 st</b>	35-60 mt	<b>38.6-66.1 st</b>
Capacity	1.25 m <sup>3</sup>	<b>1.65 yd<sup>3</sup></b>	1.5 m <sup>3</sup>	<b>2.0 yd<sup>3</sup></b>
<b>5 Tines</b>				
Operating weight:				
open	2780 kg	<b>6130 lb</b>	—	—
semi-closed	2945 kg	<b>6494 lb</b>	—	—
closed	3095 kg	<b>6813 lb</b>	—	—
narrow	—	—	2880 kg	<b>6350 lb</b>
<b>4 Tines</b>				
Operating weight:				
open	2350 kg	<b>5182 lb</b>	—	—
semi-closed	2485 kg	<b>5479 lb</b>	—	—
closed	2760 kg	<b>6086 lb</b>	—	—
narrow	—	—	2410 kg	<b>5314 lb</b>
Dimensions:				
<b>A</b>	2245 mm	<b>88"</b>	2265 mm	<b>89"</b>
<b>B</b>	1870 mm	<b>74"</b>	1880 mm	<b>74"</b>
<b>C</b>	2085 mm	<b>82"</b>	2050 mm	<b>80"</b>
<b>D</b>	3060 mm	<b>120"</b>	3050 mm	<b>120"</b>
<b>E</b>	940 mm	<b>37"</b>	955 mm	<b>38"</b>
<b>F</b>	90 mm	<b>4"</b>	90 mm	<b>4"</b>
<b>G</b>	200 mm	<b>8"</b>	200 mm	<b>8"</b>
<b>H</b>	1980 mm	<b>78"</b>	1980 mm	<b>78"</b>
<b>I</b>	2830 mm	<b>111"</b>	2820 mm	<b>111"</b>
<b>H (4 tines)</b>	2320 mm	<b>91"</b>	2320 mm	<b>91"</b>
Hydraulic open/close:				
Maximum pressure	350 bar	<b>5075 psi</b>	350 bar	<b>5075 psi</b>
Optimum flow	200 L/min	<b>53 gpm</b>	200 L/min	<b>53 gpm</b>
Hydraulic rotation:				
Maximum pressure	200 bar	<b>2900 psi</b>	200 bar	<b>2900 psi</b>
Optimum flow	20 L/min	<b>5 gpm</b>	20 L/min	<b>5 gpm</b>

**Work Tools Matching Guide**

Choosing the proper Orange Peel Grapple can increase productivity and lower your cost per ton.

---

Matching information not available. Please see marketing literature for current matching information.

# Multi-Functional Concrete Crushers Europe, Africa, Middle East

## Features Guarding Recommendation Matching Guide

### Features:

- Multi-functional operation, the crusher combines several demolition operations in one piece of equipment. Breaking out concrete from fixed structures, pulverizing concrete and cutting reinforcement rods and small steel profiles.
- High force-to-weight ratio, the crusher's special cylinder position allows it to maintain the same power with significantly lower weight.
- Enhanced performance, the standard speed valve enables cutting/crushing with great force and in even shorter cycle times.
- Optimized serviceability, the teeth and blades are replaceable and the hydraulics is easy accessible through bolted hatches.

### Guarding Recommendation

Multi-Functional Concrete Crushers used in hazardous applications like breaking out concrete from fixed structures, pulverizing concrete and cutting, can create a need for special operator guarding due to flying objects. When using a Multi-Functional Concrete Crusher, additional protective devices such as a front screen, Falling Object Guarding System (FOGS, includes top and front guarding), thick polycarbonate windshields or a combination of these is recommended by Caterpillar. Contact your Cat dealer for operator guarding options on your machine.

### Matching Guide

#### Multi-Functional Concrete Crushers

Model	Cat Excavator
<b>P315</b>	315C/D, 318C, 319C/D, 320B/C/D, 322B/C, 323D, 324D, 325B/C, 325UHD C/D, 330UHD B/C/D, 345UHD B/C, 385UHD B/C
<b>P325</b>	320D, 322B/C, 324D, 325B/C/D, 329D, 330B/C/D, 336D, 325UHD C/D, 330UHD B/C/D, 345UHD C, 365UHD B/C, 385UHD B/C
<b>P335</b>	325B/C/D, 329D, 330B/C/D, 336D, 345B/C, 365UHD BII/C, 385 UHD B/C
<b>P360</b>	345B/C, 365B/C, 385B/C

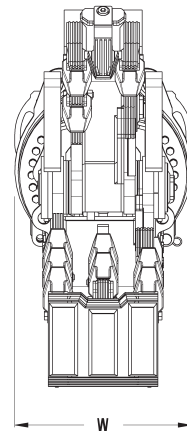
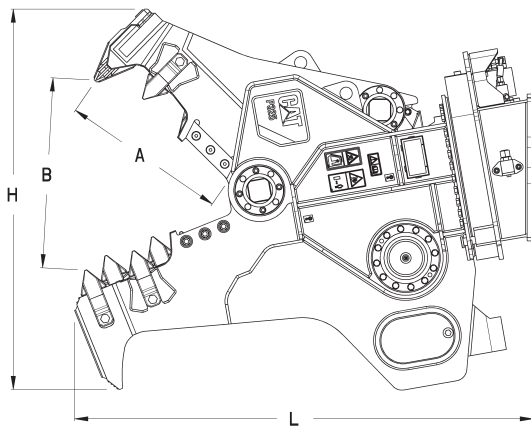

**Specifications and Dimensions**

Model	P315		P325		P335		P360	
Recommended carrier weight, stick mounted	15-25		25-35		35-60		60-85	
Weight* (approximate)	1890 kg	<b>4170 lb</b>	2550 kg	<b>5620 lb</b>	3550 kg	<b>7825 lb</b>	5230 kg	<b>11,530 lb</b>
Closing force:								
at tooth tip	90 mt	<b>99 st</b>	125 mt	<b>138 st</b>	160 mt	<b>176 st</b>	210 mt	<b>231 st</b>
at primary cutter	190 mt	<b>210 st</b>	295 mt	<b>325 st</b>	355 mt	<b>391 st</b>	455 mt	<b>501 st</b>
Dimensions:								
(L) Length	1927 mm	<b>76"</b>	2060 mm	<b>81"</b>	2398 mm	<b>130"</b>	2737 mm	<b>108"</b>
(H) Height	1543 mm	<b>61"</b>	1710 mm	<b>67"</b>	1897 mm	<b>75"</b>	2312 mm	<b>91"</b>
(W) Width	793 mm	<b>31"</b>	793 mm	<b>31"</b>	750 mm	<b>30"</b>	1180 mm	<b>46"</b>
(A) Jaw depth	657 mm	<b>26"</b>	753 mm	<b>30"</b>	877 mm	<b>35"</b>	933 mm	<b>37"</b>
(B) Jaw opening	731 mm	<b>29"</b>	855 mm	<b>34"</b>	983 mm	<b>39"</b>	1201 mm	<b>47"</b>
Cutter length	200 mm	<b>8"</b>	260 mm	<b>10"</b>	350 mm	<b>14"</b>	350 mm	<b>14"</b>
Maximum pressure:								
Crushing circuit	350 bar	<b>5076 psi</b>	350 bar	<b>5076 psi</b>	350 bar	<b>5076 psi</b>	350 bar	<b>5076 psi</b>
Rotation	140 bar	<b>2030 psi</b>	140 bar	<b>2030 psi</b>	140 bar	<b>2030 psi</b>	140 bar	<b>2030 psi</b>
Optimum flow:								
Crushing circuit	150 L/min	<b>40 gpm</b>	200 L/min	<b>53 gpm</b>	300 L/min	<b>79 gpm</b>	400 L/min	<b>105 gpm</b>
Rotation	40 L/min	<b>11 gpm</b>	40 L/min	<b>11 gpm</b>	40 L/min	<b>11 gpm</b>	80 L/min	<b>21 gpm</b>
Time to close	<b>2 sec</b>		<b>2 sec</b>		<b>2.5 sec</b>		<b>3 sec</b>	
Time to open	<b>3 sec</b>		<b>4 sec</b>		<b>4 sec</b>		<b>4 sec</b>	
Crushing capacity:								
Concrete thickness**	550 mm	<b>22"</b>	650 mm	<b>26"</b>	800 mm	<b>31"</b>	950 mm	<b>37"</b>

\*Weight excludes mounting bracket.

\*\*The concrete thickness as published provides an indication of crushing ability. The exact crushing ability depends on proper excavator adjustment, on the tip and amount of rebar, and on the condition of the concrete, jaws and crushers.



**Features:**

- **Ideal for pulverizing from non fixed structures** — The Secondary Pulverizer is an excellent choice for all those recyclers who need to prepare concrete for fine crushing and is an excellent attachment for secondary demolition. Concrete chunks released during the demolition of concrete structures can be fine-crushed at source. In this process the concrete and the reinforcement are separated. This considerably reduces the transport volume, saving dumping and transportation expenses.
- **Innovative jaw arrangement** — The Cat Secondary Pulverizer offers wide jaws with pick-up tips, large opening, reversible cutting edges and fast closing times that bring a high return on your investment. This high force-to-weight work tool has been specially developed to reduce the largest possible amount of concrete in the shortest possible time.
- **Enhanced performance** — The ripper tooth splits concrete instantly and the large number of teeth have a large pulverizing effect. The cylinder of the pulverizer is equipped with a speed valve as standard. This device controls the speed of the cylinder and enables to cut/crush with great force in short cycle times.
- **Optimized serviceability** — Service and repairs are a necessary part of operating any work tool. So the less time and money needed for both, the better. That's why Caterpillar gives major attention to reducing both. The teeth and blades are replaceable and the hydraulics are easily accessible through bolted hatches. Parts commonality is designed into Cat products to significantly benefit owners of several work tools.
- **Long lifetime** — Cat Work Tools are designed to last long. Precision machined and forged parts, wear protection and stress relieving plates as well as fully protected hydraulic cylinder provide a long lifetime of low cost production.

**Guarding Recommendation**

Hydraulic Concrete Pulverizers are used in hazardous applications like breaking out concrete from fixed structures, pulverizing concrete and cutting; creating a need for special operator guarding due to flying objects. When using these tools, additional protective devices such as a front screen, Falling Object Guarding System (FOGS, includes top and front guarding), thick polycarbonate windshields or a combination of these is recommended by Caterpillar. Contact your Cat dealer for operator guarding options on your machine.

**Matching Guide**

**Hydraulic Concrete Pulverizers**

Model	Cat Excavator
<b>P215</b>	315C/D, 318C, 319C/D, 320B/C/D, 322B/C, 323D, 324D, 325B/C/D
<b>P225</b>	320D, 322B/C, 324D, 325B/C/D, 329D, 330B/C/D, 336D
<b>P235</b>	325B/C/D, 329D, 330B/C/D, 336D, 345B/C

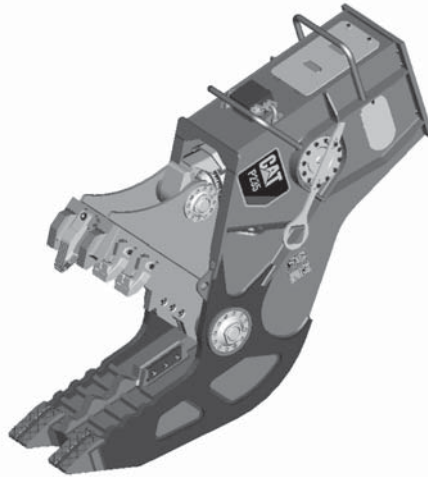

**Specifications and Dimensions**

Model	P215		P225		P235	
Recommended carrier weight***:						
Stick mounted	<b>15-25</b>		<b>25-35</b>		<b>35-60</b>	
Weight* (approximate)	1683 kg	<b>3710 lb</b>	2480 kg	<b>5467 lb</b>	3421 kg	<b>7542 lb</b>
Closing force:						
at tooth tip	121 mt	<b>133 st</b>	177 mt	<b>195 st</b>	94 mt	<b>104 st</b>
at primary cutter	235 mt	<b>259 st</b>	338 mt	<b>373 st</b>	401 mt	<b>442 st</b>
Dimensions:						
Length	2414 mm	<b>95"</b>	2615 mm	<b>103"</b>	3046 mm	<b>120"</b>
Height	1372 mm	<b>54"</b>	1645 mm	<b>65"</b>	1918 mm	<b>76"</b>
Width	580 mm	<b>23"</b>	624 mm	<b>25"</b>	708 mm	<b>28"</b>
Jaw depth	722 mm	<b>28"</b>	899 mm	<b>35"</b>	1103 mm	<b>43"</b>
Jaw opening	838 mm	<b>33"</b>	1018 mm	<b>40"</b>	1214 mm	<b>48"</b>
Cutter length	200 mm	<b>8"</b>	260 mm	<b>10"</b>	260 mm	<b>10"</b>
Maximum pressure crushing/ cutting	350 bar	<b>5076 psi</b>	350 bar	<b>5076 psi</b>	350 bar	<b>5076 psi</b>
Optimum flow crushing/cutting	150 L/min	<b>40 gpm</b>	200 L/min	<b>53 gpm</b>	300 L/min	<b>79 gpm</b>
Return flow	240 L/min	<b>63 gpm</b>	300 L/min	<b>79 gpm</b>	510 L/min	<b>135 gpm</b>
Time to close	<b>3 sec</b>		<b>3 sec</b>		<b>3.5 sec</b>	
Time to open	<b>4 sec</b>		<b>5 sec</b>		<b>4.5 sec</b>	
Crushing capacity:						
Concrete thickness**	650 mm	<b>26"</b>	750 mm	<b>30"</b>	900 mm	<b>35"</b>

\*Weight excludes mounting bracket.

\*\*The concrete thickness provides an indication of the crushing capacity. The exact crushing capability depends on excavator operation pressure and performance, on the tip and amount of rebar, and the condition of the concrete, jaws and cutters.

\*\*\*The P200 work tool can also be installed on non-Cat carriers in the listed weight classes by installing a mounting bracket with the right pin-on ears, or with hinges to fit the dedicated CW quick coupler.

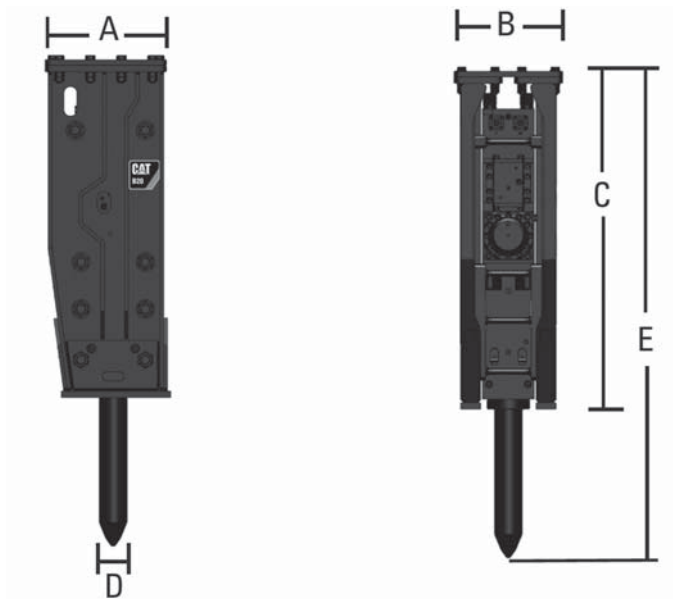

**Specifications – Top-mount Style**

Model	B8		B20		B30		B35	
Recommended carrier weight (minimum)	6 m tons	<b>6.6 tons</b>	17 m tons	<b>18.7 tons</b>	25 m tons	<b>27.6 tons</b>	30 m tons	<b>33.1 tons</b>
Recommended carrier weight (maximum)	9 m tons	<b>9.9 tons</b>	27 m tons	<b>30 tons</b>	32 m tons	<b>35.3 tons</b>	40 m tons	<b>44.1 tons</b>
Working weight*	438 kg	<b>966 lb</b>	1620 kg	<b>3571 lb</b>	2209 kg/ 2228 kg**	<b>4870 lb/ 4912 lb**</b>	3005 kg	<b>6625 lb</b>
Impact frequency	<b>460-750 bpm</b>		<b>400-800 bpm</b>		<b>350-700 bpm</b>		<b>250-550 bpm</b>	
Acceptable oil flow	45- 85 L/min	<b>12- 22 gpm</b>	125- 150 L/min	<b>33- 40 gpm</b>	160- 190 L/min	<b>42- 50 gpm</b>	180- 220 L/min	<b>48- 58 gpm</b>
Operating pressure	95- 130 bar	<b>1378- 1885 psi</b>	160- 180 bar	<b>2321- 2611 psi</b>	160- 180 bar	<b>2321- 2611 psi</b>	160- 180 bar	<b>2321- 2611 psi</b>
Dimensions:								
<b>A</b> Length	460 mm	<b>18.1"</b>	632 mm	<b>24.9"</b>	655 mm	<b>25.8"</b>	730 mm	<b>28.7"</b>
<b>B</b> Width	346 mm	<b>13.6"</b>	525 mm	<b>20.7"</b>	585 mm	<b>23.0"</b>	635 mm	<b>25.0"</b>
<b>C</b> Height (breaker)	877 mm	<b>34.5"</b>	1634 mm	<b>64.3"</b>	1829 mm	<b>72.0"</b>	1995 mm	<b>78.5"</b>
<b>D</b> Tool diameter	74.5 mm	<b>2.9"</b>	135 mm	<b>5.3"</b>	150 mm	<b>5.9"</b>	153 mm	<b>6.0"</b>
<b>E</b> Tool working length	1481 mm	<b>58.3"</b>	2389 mm	<b>94.1"</b>	2632 mm	<b>103.6"</b>	2798 mm	<b>110.2"</b>

\*Working weight includes brackets andmoil tool.

\*\*CB linkage – 2009 kg (4429 lb), DB linkage – 2228 kg (4912 lb).

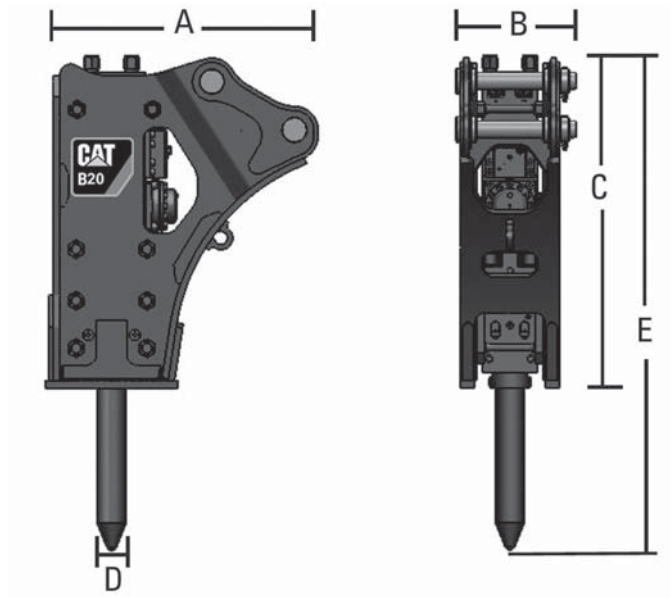

**Specifications – Side-mount Style**

Model	B20				B30					
Recommended carrier weight (minimum)	17 m tons		<b>18.7 tons</b>		25 m tons		<b>27.6 tons</b>			
Recommended carrier weight (maximum)	27 m tons		<b>29.8 tons</b>		32 m tons		<b>35.3 tons</b>			
Working weight*	1620 kg		<b>3571 lb</b>		2047 kg		<b>4513 lb</b>			
Impact frequency	<b>400-800 bpm</b>				<b>350-700 bpm</b>					
Acceptable oil flow	125-150 L/min		<b>33-40 gpm</b>		160-190 L/min		<b>42-50 gpm</b>			
Operating pressure	160-180 bar		<b>2321-2611 psi</b>		160-180 bar		<b>2321-2611 psi</b>			
<b>Linkage:</b>	<b>B/B1</b>		<b>CB/CB2</b>		<b>DB</b>		<b>CB/CB2</b>		<b>DB</b>	
Dimensions:										
<b>A</b> Length – top	1270 mm	<b>50"</b>	1302 mm	<b>51.3"</b>	1327 mm	<b>52.2"</b>	1367 mm	<b>53.8"</b>	1367 mm	<b>53.8"</b>
<b>A</b> Length – bottom	620 mm	<b>24.4"</b>	620 mm	<b>24.4"</b>	620 mm	<b>24.4"</b>	650 mm	<b>25.6"</b>	650 mm	<b>25.6"</b>
<b>B</b> Width	457 mm	<b>18"</b>	457 mm	<b>18"</b>	457 mm	<b>18"</b>	524 mm	<b>20.6"</b>	524 mm	<b>20.6"</b>
<b>C</b> Height (breaker)	1539 mm	<b>60.6"</b>	1539 mm	<b>60.6"</b>	1549 mm	<b>60.6"</b>	1725 mm	<b>67.9"</b>	1732 mm	<b>68.2"</b>
<b>D</b> Tool diameter	135 mm	<b>5.3"</b>	135 mm	<b>5.3"</b>	135 mm	<b>5.3"</b>	150 mm	<b>5.9"</b>	150 mm	<b>5.9"</b>
<b>E</b> Tool working length	2294 mm	<b>90.3"</b>	2294 mm	<b>90.3"</b>	2294 mm	<b>90.3"</b>	2530 mm	<b>99.6"</b>	2537 mm	<b>99.9"</b>

\*Working weight includes brackets andmoil tool.

**Machine Compatibility**

**Auto-Connect Quick Coupler**

Model	Linkage Hydraulic	Excavators
<b>CWAC-40</b>	—	M315D/M316D
<b>CWAC-40</b>	—	M318D/M322D
<b>CWAC-40</b>	—	315D/316E/318E
<b>CWAC-40</b>	—	319D
<b>CWAC-40</b>	B	320D/320E/321D/ 323D/323E

Auto-Connect is fast, fail-safe and reliable, and eliminates the oil spillages common with manual connections. Its design allows for high flows at low back pressures to ensure tools are used most effectively and to maintain optimum performance and matching. The design also ensures a perfect connection by balancing the connecting forces evenly across hoses. And the working pressure of the fluid maintains that connection even more securely.

Auto-Connect automatically connects up to five hydraulic ports (two high pressure and an optional drain) that typically need to be connected and disconnected by hand. That shortens the time for exchanging a hydraulic work tool from around half an hour to just a few seconds. Cutting out manual intervention also avoids potential spillage of hydraulic oil into the environment.

# MATERIAL HANDLERS

## CONTENTS

M322D2 MH, M324D2 MH	
Range Dimensions . . . . .	9-2
M322D2 MH Lifting Capacities . . . . .	9-3
M324D2 MH Lifting Capacities . . . . .	9-7
M325D MH, M325D LMH	
Dimensions . . . . .	9-15
Range Dimensions . . . . .	9-17
Lifting Capacities . . . . .	9-18
MH3022	
Specifications . . . . .	9-28
Range Dimensions . . . . .	9-29
Lifting Capacities . . . . .	9-31
MH3024	
Specifications . . . . .	9-47
Range Dimensions . . . . .	9-47
Lifting Capacities . . . . .	9-48
MH3037	
Range Diagram and Specifications . . . . .	9-88
Lifting Capacities . . . . .	9-89
MH3049	
Range Diagram and Specifications . . . . .	9-91
Lifting Capacities . . . . .	9-92
MH3059	
Range Diagram and Specifications . . . . .	9-93
Lifting Capacities . . . . .	9-94
385C MH	
Range Diagrams and Specifications . . . . .	9-95
Lifting Capacities . . . . .	9-96
Magnet Selection . . . . .	9-98
Grapple Selection . . . . .	9-98
Ferrous Scrap Specifications . . . . .	9-99

(Scrap specifications and classifications can be found in the Institute of Scrap Iron and Steel Inc.'s "Handbook." The common unit measure for the scrap industry is the gross ton which is 2240 pounds. However, short tons, net tons and metric tons may also be used.)

The versatility of Cat® material handlers, plus their ability to be equipped in any number of ways, make them an effective, low cost way to handle scrap and other materials.

**NOTE:** Contact your Cat dealer for additional information on equipping Cat Material Handlers for scrap or bulk material handling applications.

**M322D2 MH & M324D2 MH Range Diagram**

● Cat Material Handling Boom and MH Stick

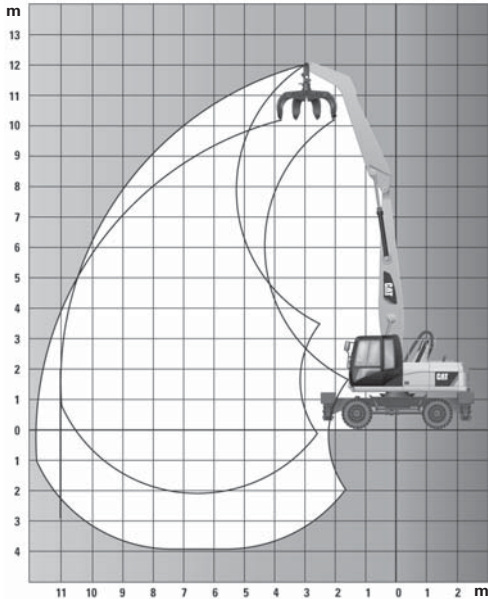

Model	M322D2 MH		M324D2 MH			
	m	ft	m	ft	m	ft
Boom	6.4	21'0"	6.8	22'3"	6.8	22'3"
Stick	4.9	16'1"	4.9	16'1"	5.9	19'4"
Maximum Horizontal Reach	11.0	36'1"	11.5	37'7"	12.5	41'0"
Maximum Vertical Pin Height	12.1	39'7"	12.5	41'0"	13.3	43'6"

**Lifting Capacities**

Equipped with Cat material handling arrangement. Capacities are measured at the bare stick tip.

**Capacities are based on level machine equipped as follows:**

- Total machine weight including base machine, material handling front, cab riser, heavy duty axles, two sets of outriggers, lubricants, full fuel tank and operator.  
 M322D2 MH — 19 150-22 350 kg (42,218-49,273 lb)  
 M324D2 MH — 20 400-24 600 kg (44,974-54,233 lb)

**M322D2 MH & M324D2 MH Range Diagram**

● Cat Material Handling Boom and Straight Stick

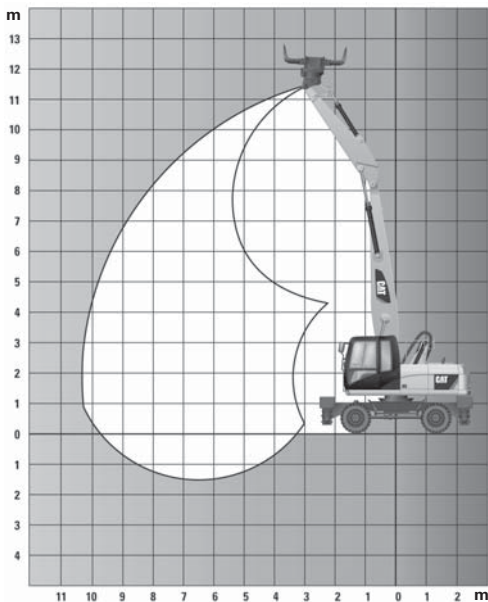

Model	M322D2 MH		M324D2 MH	
	m	ft	m	ft
Boom	6.4	21'0"	6.8	22'3"
Stick	4.2	13'8"	4.8	15'7"
Maximum Horizontal Reach	10.3	33'8"	11.4	37'4"
Maximum Vertical Pin Height	11.5	37'7"	12.4	40'7"

## Lift Capacities

All values are in kg, without bucket and without QC, with counterweight (4000 kg/8818 lb), heavy lift on.



Undercarriage		Boom 6400 mm (21'0")						Stick 4900 mm (16'1")						Metric Units			
Standard		3.0 m		4.5 m		6.0 m		7.5 m		9.0 m		10.5 m		m			
Stick height	Undercarriage configuration	Load point height	Load over front	Load over rear	Load over side	Load at maximum reach	Load point height	Load over front	Load over rear	Load over side	Load at maximum reach	Load point height	Load over front	Load over rear	Load over side	Load at maximum reach	
		10.5 m	Rear dozer up Rear dozer down Dozer and stab down					5800 4700 3950									4800 3850 3250
9.0 m	Rear dozer up Rear dozer down Dozer and stab down					5900 4800 4100			4100	3300 2800					3450 2750 2300	8.32	
7.5 m	Rear dozer up Rear dozer down Dozer and stab down					5900 4800 4100			4150	3300 2850 3200	3050	2400 2050	4800 2300		2800 2200 1850	9.42	
6.0 m	Rear dozer up Rear dozer down Dozer and stab down					5800 4700 3950			4050	3250 2750	3050	2400 2050	4800 2300		2450 1900 1600	10.18	
4.5 m	Rear dozer up Rear dozer down Dozer and stab down				8850	7100 5900	5600	4500 3800	3950	3150 2650	2950	2350 1950	2300 1800	1500 1700	2250 1750	1450 1450	10.68
3.0 m	Rear dozer up Rear dozer down Dozer and stab down	16 850 12 800 9950	12 800 *18 650 11 750	9950 *18 650	8250	6500 5350	5300	4200 3500	3800	3000 2500	2900	2250 1900	2250 1750	1450 1450	2150 1650	1350 1350	10.94
1.5 m	Rear dozer up Rear dozer down Dozer and stab down				7600	5900 4800	5000	3900 3250	3650	2850 2350	2800	2150 1800	2250 1700	1400 1400	2100 1600	1300 1300	11.00
0.0 m	Rear dozer up Rear dozer down Dozer and stab down	*3500 *3500 *3500	*3500 *3500 *3500	*3500 *3500	7200	5450 4400	4750	3650 3000	3500	2700 2250	2700	2100 1750	2200 1700	1400 1400			
-1.5 m	Rear dozer up Rear dozer down Dozer and stab down				7000	5300 4200	4600	3550 2900	3400	2600 2150	2650	2050 1700					

9

## Undercarriage Special Application

### Boom 6400 mm (21'0")

### Stick 4900 mm (16'1")

Stick height	Undercarriage configuration	3.0 m		4.5 m		6.0 m		7.5 m		9.0 m		10.5 m		m			
		Load point height	Load over front	Load over rear	Load over side	Load at maximum reach	Load point height	Load over front	Load over rear	Load over side	Load at maximum reach	Load point height	Load over front	Load over rear	Load over side	Load at maximum reach	
10.5 m	All stabilizers up All stabilizers down					5750 *6500	4350 *6500							4800 3650	6.70		
9.0 m	All stabilizers up All stabilizers down					5900 *7850	4500 *7850	4100 *6300	3100 *6300					3450 *4700	8.32		
7.5 m	All stabilizers up All stabilizers down					5900 *8200	4500 *8200	4150 *7100	3150 6450	3050 *5500	2300 4800			2800 *4400	9.42		
6.0 m	All stabilizers up All stabilizers down					5800 *8450	4400 *8450	4100 *7200	3100 6400	3050 5850	2300 4750			2450 *4300	10.18		
4.5 m	All stabilizers up All stabilizers down				8750 *11 200	6500 *11 200	5550 *8900	4200 *8900	3950 *7400	2950 6250	3000 5800	2200 4700	2350 4550	1700 3700	2250 *4300	1650 3600	10.68
3.0 m	All stabilizers up All stabilizers down	16 300 *18 650	11 000 *18 650	8150 *12 400	5950 *12 400	5300 *9400	3900 8650	3800 *7600	2850 6100	2900 5700	2150 4600	2300 4500	1700 3650	1550 4250	1550 3450	10.94	
1.5 m	All stabilizers up All stabilizers down				7550 *13 100	5350 *13 100	3650 *9650	3650 8300	2650 7400	2800 5900	2050 5600	2250 4500	1650 4450	2100 3600	1500 *4150	1500 3400	11.00
0.0 m	All stabilizers up All stabilizers down	*3500 *3500	*3500 *3500	*3500 *3500	7100 *12 200	4950 *12 200	4750 *9250	3400 8050	3500 *7200	2550 5750	2750 5500	2000 4450	2200 *4100	1600 3600			
-1.5 m	All stabilizers up All stabilizers down				6900 *9600	4800 *9600	4600 *8100	3300 7900	3400 *6300	2450 5650	2700 4400	1950 4400					

\*Limited by hydraulic rather than tipping load.

Lift capacity ratings are based on ISO 10567:2007, they do not exceed 87% of hydraulic lifting capacity or 75% of tipping load. The load point is the center line of the bucket pivot mounting pin on the stick. The oscillating axle must be locked. Lifting capacities are based on the machine standing on a firm uniform supporting surface. For lifting capacity including bucket and/or quick coupler, the respective weight has to be subtracted from above values. The use of a work tool attachment point to handle/lift objects, could affect the machine lift performance.

Always refer to the appropriate Operation and Maintenance Manual for specific product information.



**Lift Capacities**

All values are in lb, without bucket and without QC, with counterweight (4000 kg/8818 lb), heavy lift on.



Undercarriage		Boom						Stick						English Units				
Standard		6400 mm (21'0")						4900 mm (16'1")										
Undercarriage configuration	10.0 ft			15.0 ft			20.0 ft		25.0 ft		30.0 ft		35.0 ft		ft			
	Load point height	Load over front	Load over rear	Load over front	Load over rear	Load over side	Load point height	Load over front	Load over rear	Load over side	Load point height	Load over front	Load over rear	Load over side	Load at maximum reach (sticknose/bucket pin)	ft		
35.0 ft	Rear dozer up						12,400	10,000	8500						11,200	9000	7600	
	Rear dozer down							*13,400	9500							*11,800	8600	
	Dozer and stab down							*13,400	*13,400							*11,800	*11,800	
30.0 ft	Rear dozer up						12,700	10,300	8800	8800	7100	6000				7800	6200	5200
	Rear dozer down							*17,000	9800		*13,100	6800				*10,400	5900	
	Dozer and stab down							*17,000	14,200		*13,100	9800				*10,400	8700	
25.0 ft	Rear dozer up						12,700	10,300	8800	8900	7100	6100	6500	5200	6300	4900	4200	
	Rear dozer down							*17,900	9900		14,100	6800		10,300		*9800	4700	
	Dozer and stab down							*17,900	14,200		*15,500	9900		*11,000		*9800	7000	
20.0 ft	Rear dozer up						12,500	10,100	8600	8800	7000	6000	6500	5200	5400	4300	3600	
	Rear dozer down							*18,400	9600		14,000	6700		10,300		8700	4100	
	Dozer and stab down							*18,400	13,900		15,700	9800		11,600		*9500	6100	
15.0 ft	Rear dozer up				19,100	15,300	12,000	9700	8100	8500	6800	5700	6400	5000	5000	3900	3200	
	Rear dozer down					*24,300		*19,400	9200		13,700	6500		10,200		7900	3700	
	Dozer and stab down					*24,300		*19,400	13,500		15,400	9500		11,500		9000	5600	
10.0 ft	Rear dozer up	36,200	27,500	21,500	17,800	14,000	11,400	9100	7600	8200	6500	5400	6200	4900	4100	4900	3800	3100
	Rear dozer down		*40,200	25,300		*26,900		19,300	8600		13,300	6200		10,000		7900	3600	
	Dozer and stab down		*40,200	*40,200		*26,900		*20,400	12,800		15,000	9200		11,300		8900	5500	
5.0 ft	Rear dozer up				16,400	12,700	10,300	10,800	8400	7000	7800	6100	5100	6000	4700	3900	4800	3700
	Rear dozer down					*28,400	12,000	18,500	8000		12,900	5800		9800		7800	3500	
	Dozer and stab down					*28,400	18,700	20,800	12,200		14,600	8800		11,100		8800	5400	
0.0 ft	Rear dozer up	*8000	*8000	*8000	15,500	11,800	9500	10,300	7900	6500	7500	5800	4800	5900	4500	3700		
	Rear dozer down		*8000	*8000		*27,000	11,100	17,900	7500		12,600	5600		9600		7600	4300	
	Dozer and stab down		*8000	*8000		*27,000	17,700	*20,100	11,600		14,300	8500		10,900		8600		
-5.0 ft	Rear dozer up				15,000	11,400	9100	10,000	7600	6200	7400	5700	4600					
	Rear dozer down					*22,200	10,700	*17,500	7200		12,400	5400						
	Dozer and stab down					*22,200	17,300	*17,500	11,300		*13,500	8300						

**Undercarriage**

Special Application

**Boom**

6400 mm (21'0")

**Stick**

4900 mm (16'1")

Undercarriage configuration	10.0 ft		15.0 ft		20.0 ft		25.0 ft		30.0 ft		35.0 ft		ft			
	Load point height	Load over front	Load over rear	Load over front	Load over rear	Load over side	Load point height	Load over front	Load over rear	Load over side	Load point height	Load over front	Load over rear	ft		
35.0 ft	All stabilizers up							12,300	9300					11,200	8400	
	All stabilizers down							*13,400	*13,400					*11,800	*11,800	
30.0 ft	All stabilizers up							12,700	9600	8800	6700			7800	5900	
	All stabilizers down							*17,000	*17,000	*13,100	*13,100			*10,400	*10,400	
25.0 ft	All stabilizers up							12,700	9600	8900	6700	6500	4900	6300	4700	
	All stabilizers down							*17,900	*17,900	*15,500	13,900	*11,000	10,300	*9800	*9800	
20.0 ft	All stabilizers up							12,500	9400	8800	6600	6500	4900	5500	4100	
	All stabilizers down							*18,400	*18,400	*15,700	13,700	12,600	10,300	*9500	8700	
15.0 ft	All stabilizers up				18,900	14,000	12,000	9000	8500	6400	6400	4800			5000	3700
	All stabilizers down				*24,300	*24,300	*19,400	19,300	*16,100	13,500	12,500	10,100			*9500	8000
10.0 ft	All stabilizers up	35,000	23,700	17,600	12,800	11,400	8500	8200	6100	6300	4600	4900	3600	4700	3400	
	All stabilizers down	*40,200	*40,200	*26,900	*26,900	*20,400	18,600	16,300	13,100	12,300	9900	9700	7900	9300	7600	
5.0 ft	All stabilizers up				16,200	11,600	10,800	7900	7900	5800	6100	4400	4800	3500	4600	
	All stabilizers down				*28,400	*28,400	*20,900	17,900	15,900	12,700	12,100	9700	9600	7800	9200	
0.0 ft	All stabilizers up	*8000	*8000	*8000	15,300	10,700	10,300	7400	7600	5500	5900	4300				
	All stabilizers down		*8000	*8000	*27,000	*27,000	*20,100	17,300	*15,600	12,400	11,900	9600				
-5.0 ft	All stabilizers up				14,900	10,300	10,000	7100	7400	5300						
	All stabilizers down				*22,200	*22,200	*17,500	17,000	*13,500	12,200						

\*Limited by hydraulic rather than tipping load.

Lift capacity ratings are based on ISO 10567:2007, they do not exceed 87% of hydraulic lifting capacity or 75% of tipping load. The load point is the center line of the bucket pivot mounting pin on the stick. The oscillating axle must be locked. Lifting capacities are based on the machine standing on a firm uniform supporting surface. For lifting capacity including bucket and/or quick coupler, the respective weight has to be subtracted from above values. The use of a work tool attachment point to handle/lift objects, could affect the machine lift performance.

Always refer to the appropriate Operation and Maintenance Manual for specific product information.

**Lift Capacities**

All values are in kg, without bucket and without QC, with counterweight (4000 kg/8818 lb), heavy lift on.



Undercarriage		Boom						Stick						Metric Units							
Standard		6400 mm (21'0")						4200 mm (13'9")													
Undercarriage configuration	3.0 m	3.0 m		4.5 m		6.0 m		7.5 m		9.0 m		10.5 m		m							
		Load point height	Load over front	Load over front	Load over rear	Load over rear	Load over side	Load over side	Load over side	Load over side	Load over side	Load at maximum reach	Load at maximum reach								
9.0 m	Rear dozer up						5500	4350	3650					3750	2950	2450	7.42				
	Rear dozer down							*8100	4150						*5300	2800					
	Dozer and stab down							*8100	6150						*5300	4200					
7.5 m	Rear dozer up						5500	4400	3650	3750	2950	2450			2850	2200	1800	8.64			
	Rear dozer down							*8300	4150						4750	2100					
	Dozer and stab down							*8300	6150						*4950	3250					
6.0 m	Rear dozer up				8750	7000	5750	5400	4250	3550	3700	2900	2400	2650	2050	1650	2400	1850	1500	9.46	
	Rear dozer down					*10 650	6600		*8550	4050		6150	2750		4450	1950		4050	1750		
	Dozer and stab down					*10 650	9900		*8550	6050		6900	4150		5050	3000		4600	2750		
4.5 m	Rear dozer up	*14 500	13 450	10 500	8300	6550	5350	5150	4050	3350	3600	2800	2300	2600	2000	1600		2150	1600	1300	10.00
	Rear dozer down		*14 500	12 350		*11 600	6150		8900	3850		6000	2650		4400	1900		3650	1550		
	Dozer and stab down		*14 500	*14 500		*11 600	9450		*8900	5800		6750	4050		5000	2950		4150	2450		
3.0 m	Rear dozer up				7650	5900	4800	4850	3750	3100	3450	2650	2150	2550	1900	1550		2000	1500	1200	10.28
	Rear dozer down					*12 500	5550		8550	3550		5800	2500		4300	1800		3450	1400		
	Dozer and stab down					*12 500	8750		*9250	5500		6600	3900		4900	2900		3950	2300		
1.5 m	Rear dozer up				7050	5350	4250	4600	3500	2800	3250	2500	2000	2450	1850	1500		1950	1450	1150	10.34
	Rear dozer down					*12 600	5000		8200	3300		5650	2350		4200	1750		3400	1350		
	Dozer and stab down					*12 600	8150		*9200	5200		6400	3750		4800	2800		3850	2250		
0.0 m	Rear dozer up				6700	5000	3950	4350	3300	2650	3150	2350	1900	2400	1800	1400					
	Rear dozer down					*9450	4700		7950	3100		5500	2250		4150	1700					
	Dozer and stab down					*9450	7750		*8450	5000		6250	3600		4750	2750					

**Undercarriage**  
Special Application

**Boom**  
6400 mm (21'0")

**Stick**  
4200 mm (13'9")

Undercarriage configuration	3.0 m		4.5 m		6.0 m		7.5 m		9.0 m		10.5 m		m			
	Load point height	Load over front	Load over front	Load over rear	Load over rear	Load over side	Load over side	Load over side	Load over side	Load over side	Load at maximum reach	Load at maximum reach				
9.0 m	All stabilizers up					5450	4050						3750	2750	7.42	
	All stabilizers down					*8100	*8100						*5300	*5300		
7.5 m	All stabilizers up						5500	4100	3750	2750				2900	2100	8.64
	All stabilizers down						*8300	*8300	*7050	6050				*4950	4700	
6.0 m	All stabilizers up					8650	6350	5350	3950	3700	2700	2700	1900	2450	1700	9.46
	All stabilizers down					*10 650	*10 650	*8550	*8550	*7100	6000	5500	4400	*4800	4050	
4.5 m	All stabilizers up	*14 500	11 550	8200	5950	5150	3750	3600	2600	2650	1850			2200	1500	10.00
	All stabilizers down	*14 500	*14 500	*11 600	*11 600	*8900	8550	*7250	5900	5450	4350			4550	3650	
3.0 m	All stabilizers up				7600	5350	4850	3500	3450	2450	2550	1800		2050	1400	10.28
	All stabilizers down				*12 500	*12 500	*9250	8200	7200	5700	5350	4250		4300	3450	
1.5 m	All stabilizers up				7000	4850	4550	3250	3300	2300	2500	1750		2000	1350	10.34
	All stabilizers down				*12 600	*12 600	*9200	7900	7050	5550	5250	4200		*4000	3400	
0.0 m	All stabilizers up				6650	4500	4350	3050	3150	2200	2400	1650				
	All stabilizers down				*9450	*9450	*8450	7650	*6500	5400	*4850	4100				

\*Limited by hydraulic rather than tipping load.

Lift capacity ratings are based on ISO 10567:2007, they do not exceed 87% of hydraulic lifting capacity or 75% of tipping load. The load point is the center line of the bucket pivot mounting pin on the stick. The oscillating axle must be locked. Lifting capacities are based on the machine standing on a firm uniform supporting surface. For lifting capacity including bucket and/or quick coupler, the respective weight has to be subtracted from above values. The use of a work tool attachment point to handle/lift objects, could affect the machine lift performance.

Always refer to the appropriate Operation and Maintenance Manual for specific product information.

**Lift Capacities**

All values are in lb, without bucket and without QC, with counterweight (4000 kg/8818 lb), heavy lift on.



Undercarriage		Boom						Stick						English Units						
Standard		6400 mm (21'0")						4200 mm (13'9")												
Undercarriage configuration	10.0 ft			15.0 ft			20.0 ft		25.0 ft		30.0 ft		35.0 ft		ft					
30.0 ft	Rear dozer up						11,800	9300	7800						8500	6700	5600	23.85		
	Rear dozer down							*17,200	8900							*11,800	6400			
	Dozer and stab down							*17,200	13,200							*11,800	9600			
25.0 ft	Rear dozer up						11,800	9400	7900	8000	6300	5200				6400	5000	4100	28.08	
	Rear dozer down							*18,100	9000			13,200	6000				10,700	4700		
	Dozer and stab down							*18,100	13,300			14,900	9000				*10,900	7300		
20.0 ft	Rear dozer up				18,900	15,000	12,400	11,800	9200	7700	7900	6200	5100	5700	4300	3500	5400	4100	3300	30.91
	Rear dozer down					*23,100	14,200		*18,500	8700		13,200	5900		9500	4100	9000	3900		
	Dozer and stab down					*23,100	21,300		*18,500	13,000		14,800	8900		10,800	6500	10,200	6100		
15.0 ft	Rear dozer up	*31,100	29,000	22,700	17,900	14,100	11,600	11,100	8700	7200	7700	6000	4900	5600	4300	3500	4800	3600	2900	32.74
	Rear dozer down		*31,100	26,600		*25,100	13,300		19,100	8300		12,900	5700		9400	4100	8100	3400		
	Dozer and stab down		*31,100	*31,100		*25,100	20,300		*19,300	12,500		14,500	8700		10,700	6400	9200	5500		
10.0 ft	Rear dozer up				16,500	12,800	10,300	10,500	8100	6700	7400	5700	4600	5500	4100	3300	4500	3300	2600	33.73
	Rear dozer down					*27,100	12,000		18,300	7700		12,500	5400		9200	3900	7600	3100		
	Dozer and stab down					*27,100	18,900		*20,100	11,900		14,200	8400		10,500	6200	8700	2500		
5.0 ft	Rear dozer up				15,200	11,500	9200	9900	7500	6100	7100	5300	4300	5300	4000	3200	4300	3200	2500	33.92
	Rear dozer down					*27,300	10,800		17,600	7100		12,100	5100		9100	3800	7400	3000		
	Dozer and stab down					*27,300	17,500		19,900	11,300		13,800	8000		10,300	6100	8500	5000		
0.0 ft	Rear dozer up				14,400	10,800	8500	9400	7100	5700	6800	5100	4100	5200	3800	3000				
	Rear dozer down					*22,200	10,100		17,000	6700		11,800	4800		8900	3600				
	Dozer and stab down					*22,200	16,700		*18,400	10,800		13,500	7800		10,200	5900				

**Undercarriage**  
Special Application

**Boom**  
6400 mm (21'0")

**Stick**  
4200 mm (13'9")

Undercarriage configuration	10.0 ft		15.0 ft		20.0 ft		25.0 ft		30.0 ft		35.0 ft		ft			
30.0 ft	All stabilizers up						11,700	8700					8600	6300	23.85	
	All stabilizers down						*17,200	*17,200					*11,800	*11,800		
25.0 ft	All stabilizers up							8800	8000	5900				6500	4700	28.08
	All stabilizers down						*18,100	*18,100	*15,400	13,000				*10,900	10,600	
20.0 ft	All stabilizers up					18,600	13,700	11,500	8500	7900	5800	5700	4100	5400	3800	30.91
	All stabilizers down					*23,100	*23,100	*18,500	*18,500	*15,400	12,900	11,800	9400	*10,600	9000	
15.0 ft	All stabilizers up	*31,100	24,900	17,700	12,800	11,100	8100	7700	5600	5700	4000	4000	4800	3400	32.74	
	All stabilizers down	*31,100	*31,100	*25,100	*25,100	*19,300	18,400	*15,700	12,600	11,700	9400		10,100	8100		
10.0 ft	All stabilizers up				16,300	11,600	10,500	7500	7400	5300	5500	3900	4500	3100	33.73	
	All stabilizers down				*27,100	*27,100	*20,100	17,700	15,500	12,300	11,500	9200	9500	7600		
5.0 ft	All stabilizers up				15,100	10,400	9900	7000	7100	5000	5300	3700	4400	3000	33.92	
	All stabilizers down				*27,300	*27,300	*20,000	17,000	15,100	11,900	11,300	9000	*8900	7500		
0.0 ft	All stabilizers up				14,300	9,800	9400	6500	6800	4700	5200	3600				
	All stabilizers down				*22,200	*22,200	*18,400	16,400	*14,000	11,700	*10,400	8900				

\*Limited by hydraulic rather than tipping load.

Lift capacity ratings are based on ISO 10567:2007, they do not exceed 87% of hydraulic lifting capacity or 75% of tipping load. The load point is the center line of the bucket pivot mounting pin on the stick. The oscillating axle must be locked. Lifting capacities are based on the machine standing on a firm uniform supporting surface. For lifting capacity including bucket and/or quick coupler, the respective weight has to be subtracted from above values. The use of a work tool attachment point to handle/lift objects, could affect the machine lift performance.

Always refer to the appropriate Operation and Maintenance Manual for specific product information.

**Lift Capacities**

All values are in kg, without bucket and without QC, with counterweight (5400 kg/11,905 lb), heavy lift on.

**Undercarriage** Standard      **Boom** 6800 mm (22'4")      **Stick** 5900 mm (19'4")      **Metric Units**

Undercarriage configuration	3.0 m		4.5 m		6.0 m		7.5 m		9.0 m		10.5 m		12.0 m		Load at maximum reach (sticks on se/bucket pin)	
	Load over front	Load over rear	Load over front	Load over rear	Load over front	Load over rear	Load over front	Load over rear	Load over front	Load over rear	Load over front	Load over rear	Load over front	Load over rear	Load over front	Load over rear
12.0 m	Rear dozer up	5300	5900	5000	5100	4150	3800	3100	2650	2300	1950	1700	1400	1100	4500	3750
	Rear dozer down															
	Dozer and stab down															
10.5 m	Rear dozer up				5050	4150	3800	3100	2650	2300	1950	1700	1400	1100	4650	2800
	Rear dozer down															
	Dozer and stab down															
9.0 m	Rear dozer up				5100	4250	3850	3750	3100	2650	2300	1950	1700	1400	4600	2050
	Rear dozer down															
	Dozer and stab down															
7.5 m	Rear dozer up				5100	4200	3800	3750	3100	2650	2300	1950	1700	1400	4600	3300
	Rear dozer down															
	Dozer and stab down															
6.0 m	Rear dozer up				5000	4100	3650	3700	3000	2600	2300	1950	1700	1400	4400	2850
	Rear dozer down															
	Dozer and stab down															
4.5 m	Rear dozer up				6850	5650	4800	3950	3350	3800	2900	2500	2800	2250	1900	2200
	Rear dozer down															
	Dozer and stab down															
3.0 m	Rear dozer up				10300	8200	6850	4400	4600	3700	3150	2700	2150	1800	2150	1400
	Rear dozer down															
	Dozer and stab down															
1.5 m	Rear dozer up				9200	7350	6000	4000	4350	3300	2800	2650	2100	1750	2150	1400
	Rear dozer down															
	Dozer and stab down															
0.0 m	Rear dozer up				*4050	*4050	5850	4450	3650	4100	3250	2700	2000	1650	2100	1350
	Rear dozer down															
	Dozer and stab down															
-1.5 m	Rear dozer up				8100	6250	5000	3450	3850	3100	2550	2000	1600	1300	1600	1000
	Rear dozer down															
	Dozer and stab down															

\* Limited by hydraulic rather than tipping load.  
Lift capacity ratings are based on ISO 10567:2007; they do not exceed 97% of hydraulic lifting capacity or 75% of tipping load. The load point is the center line of the bucket pivot mounting pin on the stick. The oscillating axle must be locked. Lifting capacities are based on the machine standing on a firm uniform supporting surface. For lifting capacity including bucket and/or quick coupler, the respective weight has to be subtracted from above values. The use of a work tool attachment point to handle/lift objects, could affect the machine lift performance.  
Always refer to the appropriate Operation and Maintenance Manual for specific product information.

### Lift Capacities

All values are in lb, without bucket and without QC, with counterweight (5400 kg/11,905 lb), heavy lift on.

Undercarriage	Boom	Stick	English Units
Standard	6800 mm (22'4")	5900 mm (19'4")	

Undercarriage configuration	Load over front		Load over rear		Load over side		Load at maximum reach (sticks w/ bucket pin)		ft
	100.0 ft	150.0 ft	20.0 ft	25.0 ft	30.0 ft	35.0 ft	40.0 ft		
40.0 ft Rear dozer up Rear dozer down Dozer and stab down	15,000	10,800	10,800	8,900	7,600			12,500 12,900 12,900	8800 9800 *12,900
35.0 ft Rear dozer up Rear dozer down Dozer and stab down			10,800	8,900	7,600			8,400 8,400 *11,100	5900 6800 *11,100
30.0 ft Rear dozer up Rear dozer down Dozer and stab down			11,000	9,100	7,800	8,000		6,700 6,700 *10,200	4600 4600 *10,200
25.0 ft Rear dozer up Rear dozer down Dozer and stab down			10,900	9,100	7,800	8,100		5,700 5,700 *10,200	3900 3900 *10,200
20.0 ft Rear dozer up Rear dozer down Dozer and stab down			10,700	8,900	7,600	8,000		5,100 5,100 *10,200	3400 3400 *10,200
15.0 ft Rear dozer up Rear dozer down Dozer and stab down			14,800	12,200	10,300	8,500	7,200	4,700 4,700 *10,200	3100 3100 *10,200
10.0 ft Rear dozer up Rear dozer down Dozer and stab down			21,900	17,700	14,800	13,900	9,900	4,700 4,700 *10,200	2900 2900 *10,200
5.0 ft Rear dozer up Rear dozer down Dozer and stab down			19,800	15,800	13,000	12,900	10,400	4,700 4,700 *10,200	2800 2800 *10,200
0.0 ft Rear dozer up Rear dozer down Dozer and stab down			*9,300	*9,300	*9,300	*9,300	*9,300	4,700 4,700 *10,200	3100 3100 *10,200
-5.0 ft Rear dozer up Rear dozer down Dozer and stab down			17,400	13,500	10,800	11,600	8,500	4,700 4,700 *10,200	2800 2800 *10,200

\*Limited by hydraulic rather than tipping load.  
Lift capacity ratings are based on ISO 10567:2007; they do not exceed 97% of hydraulic lifting capacity or 75% of tipping load. The load point is the center line of the bucket pivot mounting pin on the stick. The oscillating axle must be locked. Lifting capacities are based on the machine standing on a firm uniform supporting surface. For lifting capacity including bucket and/or quick coupler, the respective weight has to be subtracted from above values. The use of a work tool attachment point to handle/lift objects, could affect the machine lift performance.  
Always refer to the appropriate Operation and Maintenance Manual for specific product information.

## Lift Capacities

All values are in kg, without bucket and without QC, with counterweight (5400 kg/11,905 lb), heavy lift on.



Undercarriage	Boom												Stick			Metric Units
Standard	6800 mm (22'4")												4900 mm (16'1")			

		4.5 m			6.0 m			7.5 m			9.0 m			10.5 m						
10.5 m	Rear dozer up				7000	5800	4950	4800	3950	3350							4800	3950	3350	7.50
	Rear dozer down					*9200	5500		*6350	3750								*6350	3750	
	Dozer and stab down					*9200	7750		*6350	5300								*6350	5300	
9.0 m	Rear dozer up				7100	5900	5050	4950	4050	3500							3600	2950	2500	8.98
	Rear dozer down					*9300	5600		7750	3900								5650	2800	
	Dozer and stab down					*9300	7850		*8100	5450								*5750	4000	
7.5 m	Rear dozer up				7050	5850	5000	4950	4050	3500	3650	3000	2550				3050	2450	2050	10.02
	Rear dozer down					*9350	5550		7750	3900								4750	2350	
	Dozer and stab down					*9350	7800		*8050	5450								5250	3350	
6.0 m	Rear dozer up				6900	5700	4850	4850	4000	3400	3600	2950	2500	2800	2250	1900	2700	2150	1800	10.74
	Rear dozer down					*9700	5400		7650	3800								4200	2050	
	Dozer and stab down					*9700	7650		*8200	5350								4700	3000	
4.5 m	Rear dozer up	10 400	8500	7100	6600	5400	4550	4700	3800	3250	3550	2850	2450	2750	2200	1850	2450	1950	1650	11.22
	Rear dozer down		*13 150	8000		*10 300	5150		7450	3650					4350	2100		3900	1900	
	Dozer and stab down		*13 150	11 700		*10 300	7350		8250	5200					6150	3950		4850	3100	
3.0 m	Rear dozer up	9600	7750	6400	6200	5050	4250	4500	3650	3050	3400	2750	2300	2700	2150	1800	2350	1850	1550	11.47
	Rear dozer down		*14 550	7250		10 450	4800		7250	3450					4300	2050		3750	1800	
	Dozer and stab down		*14 550	10 850		*10 850	6950		8000	5000					4750	3000		4150	2650	
1.5 m	Rear dozer up	8850	7000	5700	5850	4700	3900	4300	3450	2850	3300	2650	2200	2650	2100	1750	2300	1800	1500	11.52
	Rear dozer down		*15 050	6550		10 000	4450		7000	3250					4200	2000		3700	1750	
	Dozer and stab down		*15 050	10 050		*11 050	6550		7750	4800					4700	2950		4100	2600	
0.0 m	Rear dozer up	8350	6550	5250	5550	4400	3650	4100	3250	2700	3200	2550	2100	2600	2050	1700				
	Rear dozer down		*10 200	6100		9700	4150		6800	3100					4150	1950				
	Dozer and stab down		*10 200	9550		*10 550	6300		7600	4600					5800	3600		4650	2900	
-1.5 m	Rear dozer up				5400	4250	3500	4000	3150	2600										
	Rear dozer down					*9150	4000		6700	3000										
	Dozer and stab down					*9150	6150		*7250	4500										

\* Limited by hydraulic rather than tipping load.

Lift capacity ratings are based on ISO 10567:2007, they do not exceed 87% of hydraulic lifting capacity or 75% of tipping load. The load point is the center line of the bucket pivot mounting pin on the stick. The oscillating axle must be locked. Lifting capacities are based on the machine standing on a firm uniform supporting surface. For lifting capacity including bucket and/or quick coupler, the respective weight has to be subtracted from above values. The use of a work tool attachment point to handle/lift objects, could affect the machine lift performance.

Always refer to the appropriate Operation and Maintenance Manual for specific product information.

**Lift Capacities**

All values are in lb, without bucket and without QC, with counterweight (5400 kg/11,905 lb), heavy lift on.

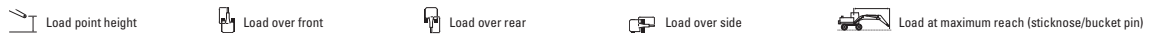

**Undercarriage**      **Boom**      **Stick**      **English Units**  
Standard      6800 mm (22'4")      4900 mm (16'1")

Stick height	Undercarriage configuration	15.0 ft			20.0 ft			25.0 ft			30.0 ft			35.0 ft			ft				
		Load point height	Load over front	Load over rear	Load over front	Load over rear	Load over side	Load over front	Load over rear	Load over side	Load over front	Load over rear	Load over side	Load over front	Load over rear	Load over side					
35.0 ft	Rear dozer up				15,000	12,400	10,600										11,100	9100	7800	23.95	
	Rear dozer down					*19,500	11,800											*14,200	8700		
	Dozer and stab down					*19,500	16,600											*14,200	12,300		
30.0 ft	Rear dozer up				15,200	12,600	10,800	10,600	8700	7500							8200	6700	5700	29.07	
	Rear dozer down					*20,300	12,000			16,600	8300								*12,700		6400
	Dozer and stab down					*20,300	16,800			*17,700	11,700								*12,700		9000
25.0 ft	Rear dozer up				15,200	12,600	10,700	10,600	8700	7500	7800	6400	5500				6800	5500	4600	32.64	
	Rear dozer down					*20,400	12,000			16,700	8400	12,200	6100					10,600	5200		
	Dozer and stab down					*20,400	16,800			*17,600	11,700	13,500	8700					11,700	7500		
20.0 ft	Rear dozer up				14,800	12,200	10,400	10,400	8600	7300	7800	6300	5400	6000	4800	4000	5900	4800	4000	35.10	
	Rear dozer down					*21,100	11,600			16,500	8200	12,200	6100					9300	4600		
	Dozer and stab down					*21,100	16,400			*17,900	11,500	13,400	8600					10,400	6700		
15.0 ft	Rear dozer up	22,400	18,300	15,300	14,200	11,600	9900	10,100	8200	7000	7600	6200	5200	5900	4800	4000	5500	4400	3700	36.75	
	Rear dozer down		*28,500	17,300		*22,300	11,100			16,100	7900	12,000	5900	9300	4500			8600	4200		
	Dozer and stab down		*28,500	25,200		*22,300	15,800			17,700	11,200	13,200	8500			10,400	6600		9600		6100
10.0 ft	Rear dozer up	20,700	16,700	13,800	13,400	10,900	9100	9700	7800	6600	7400	5900	5000	5800	4600	3900	5200	4100	3400	37.63	
	Rear dozer down		*31,400	15,700		22,500	10,300			15,600	7500	11,700	5700	9200	4400			8200	3900		
	Dozer and stab down		*31,400	23,400		*23,500	15,000			17,200	10,800	13,000	8200			10,300	6500		9200		5800
5.0 ft	Rear dozer up	19,100	15,100	12,300	12,600	10,100	8400	9200	7400	6200	7100	5700	4800	5700	4500	3800	5100	4000	3300	37.83	
	Rear dozer down		*32,600	14,200		21,500	9600			15,100	7000	11,400	5400	9100	4300			8100	3800		
	Dozer and stab down		*32,600	21,700		23,800	14,200			16,700	10,300	12,700	8000			10,100	6400		9100		5700
0.0 ft	Rear dozer up	18,000	14,100	11,400	12,000	9500	7900	8900	7100	5900	6900	5500	4600	5600	4400	3700					
	Rear dozer down		*23,900	13,200		20,800	9000			14,700	6700	11,200	5200			9000	4200				
	Dozer and stab down		*23,900	20,600		*22,900	13,600			16,300	10,000	12,500	7800			10,000	6300				
-5.0 ft	Rear dozer up				11,700	9200	7500	8700	6800	5700											
	Rear dozer down					*19,800	8700			14,400	6500										
	Dozer and stab down					*19,800	13,200			*15,600	9,700										

\* Limited by hydraulic rather than tipping load.

Lift capacity ratings are based on ISO 10567:2007, they do not exceed 87% of hydraulic lifting capacity or 75% of tipping load. The load point is the center line of the bucket pivot mounting pin on the stick. The oscillating axle must be locked. Lifting capacities are based on the machine standing on a firm uniform supporting surface. For lifting capacity including bucket and/or quick coupler, the respective weight has to be subtracted from above values. The use of a work tool attachment point to handle/lift objects, could affect the machine lift performance.

Always refer to the appropriate Operation and Maintenance Manual for specific product information.

**Lift Capacities**

All values are in kg, without bucket and without QC, with counterweight (5400 kg/11,905 lb), heavy lift on.

 Load point height

 Load over front

 Load over rear

 Load over side

 Load at maximum reach (sticknose/bucket pin)

**Undercarriage**

**Boom**





















**Stick**

**Metric Units**

Standard

6800 mm (22'4")

4800 mm (15'9")

Undercarriage configuration	4.5 m			6.0 m			7.5 m			9.0 m			10.5 m			Load at maximum reach (sticknose/bucket pin)			m		
																					
10.5 m Rear dozer up Rear dozer down Dozer and stab down				6700	5500 *8900	4650 5200												4650	3750 *6200	3150 3550	7.35
9.0 m Rear dozer up Rear dozer down Dozer and stab down				6800	5600 *9050	4750 5300	4600	3750 *7750	3150 3550									3400	2700 5500	2250 2550	8.86
7.5 m Rear dozer up Rear dozer down Dozer and stab down				6750	5550 *9100	4700 5250	4600	3750 *7900	3150 3550	3350	2650	2200						2750	2150 4500	1800 2050	9.91
6.0 m Rear dozer up Rear dozer down Dozer and stab down				6550	5350 *9400	4500 5100	4500	3650 *7900	3050 3450	3300	2600	2200	2450	1900	1550			2400	1850 3950	1500 1750	10.64
4.5 m Rear dozer up Rear dozer down Dozer and stab down	10 050	8100 *12 900	6700 7650	6250	5050 *9950	4200 4800	4350	3500 7150	2900 3300	3200	2500	2100	2450	1900	1550			2150	1650 4000	1350 1800	11.12
3.0 m Rear dozer up Rear dozer down Dozer and stab down	9200	7300 *14 150	5950 6850	5850	4650 *10 450	3850 4400	4100	3250 6900	2700 3100	3050	2400	1950	2350	1800	1450			2050	1550 3950	1250 1700	11.38
1.5 m Rear dozer up Rear dozer down Dozer and stab down	8350	6500 *14 550	5200 6050	5450	4300 *10 600	3500 4050	3900	3050 6650	2500 2900	2950	2300	1850	2300	1750	1400			2000	1500 3900	1200 1650	11.43
0.0 m Rear dozer up Rear dozer down Dozer and stab down	7850	6050 *9650	4800 5600	5150	4000 *10 000	3200 3750	3750	2900 6450	2350 2700	2850	2200	1750	2250	1700	1350				3800 1600		
-1.5 m Rear dozer up Rear dozer down Dozer and stab down				5000	3850 *8550	3050 3600	3600	2800 *6700	2250 4100												

\* Limited by hydraulic rather than tipping load.

Lift capacity ratings are based on ISO 10567:2007, they do not exceed 87% of hydraulic lifting capacity or 75% of tipping load. The load point is the center line of the bucket pivot mounting pin on the stick. The oscillating axle must be locked. Lifting capacities are based on the machine standing on a firm uniform supporting surface. For lifting capacity including bucket and/or quick coupler, the respective weight has to be subtracted from above values. The use of a work tool attachment point to handle/lift objects, could affect the machine lift performance.

Always refer to the appropriate Operation and Maintenance Manual for specific product information.



**Lift Capacities**

All values are in lb, without bucket and without QC, with counterweight (5400 kg/11,905 lb), heavy lift on.

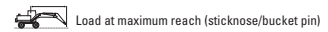
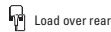

**Undercarriage**

**Boom**

**Stick**

**English Units**

Standard

6800 mm (22'4")

4800 mm (15'9")

Stick	Undercarriage configuration	15.0 ft			20.0 ft			25.0 ft			30.0 ft			35.0 ft			ft		
		Load point height	Load over front	Load over rear	Load point height	Load over front	Load over rear	Load point height	Load over front	Load over rear	Load point height	Load over front	Load over rear	Load point height	Load over front	Load over rear	ft		
35.0 ft	Rear dozer up				14,300	11,700	9900										10,700	8700	7300
	Rear dozer down					*18,800	11,100											*13,900	8300
	Dozer and stab down					*18,800	15,900											*13,900	12,000
30.0 ft	Rear dozer up				14,600	12,000	10,100	9900	8000	6800							7600	6100	5100
	Rear dozer down					*19,700	11,400											*12,400	5800
	Dozer and stab down					*19,700	16,200		*17,000	11,000								*12,400	8500
25.0 ft	Rear dozer up				14,500	11,900	10,100	9900	8000	6800	7100	5700	4700				6200	4800	4000
	Rear dozer down					*19,800	11,300					11,500	5400					10,000	4600
	Dozer and stab down					*19,800	16,100		*16,900	11,000		12,800	8000					11,200	6900
20.0 ft	Rear dozer up				14,100	11,500	9700	9700	7800	6600	7100	5600	4700				5300	4100	3400
	Rear dozer down					*20,500	10,900					11,400	5300					8800	3900
	Dozer and stab down					*20,500	15,700		*17,100	10,800		12,700	7900					9800	6000
15.0 ft	Rear dozer up	21,600	17,500	14,500	13,400	10,900	9100	9300	7500	6200	6900	5400	4500	5200	4000	3300	4800	3700	3000
	Rear dozer down		*27,900	16,500		*21,600	10,300					11,200	5100		8600	3800		8000	3500
	Dozer and stab down		*27,900	24,400		*21,600	15,000					12,500	7700		9700	5900		9000	5500
10.0 ft	Rear dozer up	19,800	15,700	12,900	12,600	10,000	8300	8900	7000	5800	6600	5200	4200	5100	3900	3100	4500	3400	2700
	Rear dozer down		*30,600	14,800		21,700	9500					10,900	4900		8500	3700		7600	3200
	Dozer and stab down		*30,600	22,500		*22,700	14,200					12,200	7500		9500	5800		8600	5100
5.0 ft	Rear dozer up	18,000	14,000	11,300	11,700	9200	7500	8400	6600	5400	6300	4900	4000	4900	3800	3000	4400	3300	2600
	Rear dozer down		*31,500	13,100		20,600	8700					10,700	4600		8300	3500		7500	3100
	Dozer and stab down		*31,500	20,600		22,900	13,300					11,900	7200		9400	5600		8400	5000
0.0 ft	Rear dozer up	16,900	13,000	10,300	11,100	8600	6900	8000	6200	5000	6100	4700	3800	4800	3700	2900			
	Rear dozer down		*22,600	12,100		19,800	8100					10,400	4400		8200	3400			
	Dozer and stab down		*22,600	19,500		*21,700	12,600					11,700	7000		9300	5500			
-5.0 ft	Rear dozer up				10,700	8300	6600	7800	6000	4800									
	Rear dozer down					*18,500	7700												
	Dozer and stab down					*18,500	12,300		*14,400	8900									

\*Limited by hydraulic rather than tipping load.

Lift capacity ratings are based on ISO 10567:2007, they do not exceed 87% of hydraulic lifting capacity or 75% of tipping load. The load point is the center line of the bucket pivot mounting pin on the stick. The oscillating axle must be locked. Lifting capacities are based on the machine standing on a firm uniform supporting surface. For lifting capacity including bucket and/or quick coupler, the respective weight has to be subtracted from above values. The use of a work tool attachment point to handle/lift objects, could affect the machine lift performance.

Always refer to the appropriate Operation and Maintenance Manual for specific product information.

**Lift Capacities**

All values are in kg, without bucket and without QC, with counterweight (5400 kg/11,905 lb), heavy lift on.

**Metric Units**

		Load point height	Load over front	Load over rear	Load over side		Load at maximum reach (sticknose/bucket pin)											
Undercarriage Special Application	Undercarriage configuration	3.0 m		4.5 m		6.0 m		7.5 m		9.0 m		10.5 m		12.0 m		m		
12.0 m	All stabilizers up					7000	5400									5300	4050	
	All stabilizers down					*7450	*7450									*5700	*5700	
10.5 m	All stabilizers up							5000	3900								3700	2850
	All stabilizers down							*7250	*7250								*4950	*4950
9.0 m	All stabilizers up							5100	3950	3750	2900						3000	2250
	All stabilizers down							*7500	*7500	*6750	5700						*4600	4600
7.5 m	All stabilizers up							5050	3950	3750	2900	2850	2150				2550	1950
	All stabilizers down							*7550	*7550	*6700	5700	5350	4400				*4400	4000
6.0 m	All stabilizers up							4950	3850	3700	2850	2850	2150				2300	1700
	All stabilizers down							*7750	7550	*6800	5650	5350	4400				*4300	3600
4.5 m	All stabilizers up					6800	5200	4800	3650	3600	2750	2800	2100	2200	1650	2150	1600	
	All stabilizers down					*9550	*9550	*8050	7350	6750	5500	5250	4300	4250	3500	4150	3400	
3.0 m	All stabilizers up			9950	7400	6400	4850	4550	3450	3450	2600	2700	2000	2200	1600	2050	1500	
	All stabilizers down			*13 400	*13 400	*10 300	*10 200	*8400	7100	6600	5350	5200	4250	4200	3450	4000	3250	
1.5 m	All stabilizers up			9050	6600	5950	4400	4300	3200	3300	2450	2650	1950	2150	1550	2000	1450	
	All stabilizers down			*14 700	*14 700	*10 850	9700	8500	6850	6400	5200	5100	4150	4150	3400	3950	3200	
0.0 m	All stabilizers up	*4050	*4050	8350	5950	5550	4050	4100	3000	3200	2350	2550	1850	2100	1500			
	All stabilizers down	*4050	*4050	*14 700	*14 700	*10 800	9250	8250	6600	6250	5050	5000	4050	*4050	3350			
-1.5 m	All stabilizers up			7950	5600	5300	3850	3950	2850	3100	2250	2500	1800					
	All stabilizers down			*10 450	*10 450	*10 000	8950	*7850	6450	6150	4950	*2480	4000					

**Undercarriage**  
Special Application

**Boom**  
6800 mm (22'4")

**Stick**  
4900 mm (16'1")

Undercarriage configuration	4.5 m		6.0 m		7.5 m		9.0 m		10.5 m		m		
10.5 m	All stabilizers up			6950	5350	4800	3700				4800	3700	
	All stabilizers down			*9200	*9200	*6350	*6350				*6350	*6350	
9.0 m	All stabilizers up			7000	5450	4900	3800				3600	2750	
	All stabilizers down			*9300	*9300	*8100	7500				*5750	5550	
7.5 m	All stabilizers up			7000	5400	4900	3800	3650	2800		3050	2300	
	All stabilizers down			*9350	*9350	*8050	7500	6800	5550		*5450	4650	
6.0 m	All stabilizers up			6800	5250	4800	3700	3600	2750	2800	2100	2000	
	All stabilizers down			*9700	*9700	*8200	7400	6750	5550	5250	4300	5050	4150
4.5 m	All stabilizers up	10 250	7650	6550	5000	4650	3550	3550	2700	2750	2100	2500	1850
	All stabilizers down	*13 150	*13 150	*10 300	*10 300	*8450	7200	6650	5450	5200	4300	4700	3850
3.0 m	All stabilizers up	9450	6950	6150	4650	4450	3350	3400	2600	2700	2050	2350	1750
	All stabilizers down	*14 550	*14 550	*10 850	9950	8650	7000	6550	5300	5150	4200	4500	3700
1.5 m	All stabilizers up	8700	6300	5800	4300	4250	3200	3300	2450	2650	1950	2300	1700
	All stabilizers down	*15 050	*15 050	*11 050	9500	8450	6800	6400	5200	5100	4150	*4450	3650
0.0 m	All stabilizers up	8250	5850	5550	4050	4100	3050	3200	2350	2600	1900		
	All stabilizers down	*10 200	*10 200	*10 550	9200	*8250	6600	6300	5100	*5000	4100		
-1.5 m	All stabilizers up			5400	3900	4000	2950						
	All stabilizers down			*9150	9000	*7250	6500						

**Undercarriage**  
Special Application

**Boom**  
6800 mm (22'4")

**Stick**  
4800 mm (15'9")

Undercarriage configuration	4.5 m		6.0 m		7.5 m		9.0 m		10.5 m		m		
10.5 m	All stabilizers up			6600	5050						4600	3500	
	All stabilizers down			*8900	*8900						*6200	*6200	
9.0 m	All stabilizers up			6750	5150	4600	3500				3350	2500	
	All stabilizers down			*9050	*9050	*7750	7200				*5650	5350	
7.5 m	All stabilizers up			6700	5100	4600	3450	3300	2450		2750	2000	
	All stabilizers down			*9100	*9100	*7750	7200	6450	5250		*5250	4400	
6.0 m	All stabilizers up			6500	4900	4500	3400	3300	2450	2450	1750	2400	1700
	All stabilizers down			*9400	*9400	*7900	7050	6400	5200	4900	4000	4800	3900
4.5 m	All stabilizers up	9850	7300	6200	4650	4300	3200	3200	2350	2450	1750	2150	1550
	All stabilizers down	*12 900	*12 900	*9950	*9950	*8100	6900	6300	5100	4900	3950	4450	3550
3.0 m	All stabilizers up	9050	6550	5800	4250	4100	3000	3050	2250	2350	1700	2050	1450
	All stabilizers down	*14 150	*14 150	*10 450	9550	*8300	6650	6200	4950	4800	3900	4250	3400
1.5 m	All stabilizers up	8250	5800	5400	3900	3900	2800	2900	2100	2300	1600	2000	1400
	All stabilizers down	*14 550	*14 550	*10 600	9100	8050	6400	6050	4850	4750	3800	*4100	3350
0.0 m	All stabilizers up	7750	5350	5100	3600	3700	2650	2850	2000	2250	1550		
	All stabilizers down	*9650	*9650	*10 000	8750	*7750	6200	5900	4750	*4500	3750		
-1.5 m	All stabilizers up			4950	3450	3600	2550						
	All stabilizers down			*8550	*8550	*6700	6100						

\*Limited by hydraulic rather than tipping load.

Lift capacity ratings are based on ISO 10567:2007, they do not exceed 87% of hydraulic lifting capacity or 75% of tipping load. The load point is the center line of the bucket pivot mounting pin on the stick. The oscillating axle must be locked. Lifting capacities are based on the machine standing on a firm uniform supporting surface. For lifting capacity including bucket and/or quick coupler, the respective weight has to be subtracted from above values. The use of a work tool attachment point to handle/lift objects, could affect the machine lift performance.

Always refer to the appropriate Operation and Maintenance Manual for specific product information.

**Lift Capacities**

All values are in lb, without bucket and without QC, with counterweight (5400 kg/11,905 lb), heavy lift on.

**English Units**

		Load point height	Load over front	Load over rear	Load over side	Load at maximum reach (sticknose/bucket pin)											
Undercarriage Special Application	Undercarriage configuration	10.0 ft		15.0 ft		20.0 ft		25.0 ft		30.0 ft		35.0 ft		40.0 ft		ft	
40.0 ft	All stabilizers up					14,900	11,500									12,400	9500
	All stabilizers down					*15,600	*15,600									*12,900	*12,900
35.0 ft	All stabilizers up							10,700	8300							8400	6500
	All stabilizers down							*15,400	*15,400							*11,100	*11,100
30.0 ft	All stabilizers up							10,900	8500	8000	6200					6700	5100
	All stabilizers down							*16,400	*16,400	*14,400	12,200					*10,200	*10,200
25.0 ft	All stabilizers up							10,900	8500	8100	6200	6100	4600			5700	4300
	All stabilizers down							*16,400	*16,400	*14,600	12,200	11,500	9400			*9700	8900
20.0 ft	All stabilizers up							10,700	8300	7900	6100	6100	4600			5100	3800
	All stabilizers down							*16,800	16,300	14,700	12,100	11,400	9400			*9500	8000
15.0 ft	All stabilizers up							14,600	11,200	10,300	7900	7700	6000	4500		4700	3500
	All stabilizers down							*20,700	*20,700	*17,500	15,900	14,500	11,300	9300		9100	7500
10.0 ft	All stabilizers up					21,500	16,000	13,800	10,400	9800	7500	7400	5600	5800	4300	4700	3400
	All stabilizers down					*29,000	*29,000	*22,300	21,900	*18,200	15,300	14,200	11,600	11,100	9100	9100	7400
5.0 ft	All stabilizers up					19,500	14,200	12,800	9500	9300	7000	7100	5300	5700	4200	4600	3300
	All stabilizers down					*31,800	*31,800	*23,500	20,800	18,300	14,700	13,800	11,200	10,900	8900	9000	7300
0.0 ft	All stabilizers up	*9300	*9300	18,000	12,800	12,000	8800	8800	6500	6900	5000	5500	4000				
	All stabilizers down	*9300	*9300	*31,900	*31,900	*23,400	19,900	17,800	14,200	13,500	10,900	10,800	8800				
-5.0 ft	All stabilizers up					17,100	12,100	11,500	8300	8500	6200	6600	4800	5400	3900		
	All stabilizers down					*24,000	*24,000	*21,700	19,300	*16,900	13,800	13,300	10,700	*10,200	8600		

Undercarriage Special Application	Undercarriage configuration	15.0 ft		20.0 ft		25.0 ft		30.0 ft		35.0 ft		ft	
35.0 ft	All stabilizers up					14,800	11,400					11,000	8500
	All stabilizers down					*19,500	*19,500					*14,200	*14,200
30.0 ft	All stabilizers up					15,100	11,700	10,500	8200			8100	6200
	All stabilizers down					*20,300	*20,300	*17,700	16,100			*12,700	12,500
25.0 ft	All stabilizers up					15,000	11,600	10,600	8200	7800	6000	6800	5100
	All stabilizers down					*20,400	*20,400	*17,600	16,100	14,600	12,000	*12,000	10,400
20.0 ft	All stabilizers up					14,700	11,300	10,400	8000	7800	5900	6000	4500
	All stabilizers down					*21,100	*21,100	*17,900	15,900	14,500	11,900	11,300	9300
15.0 ft	All stabilizers up	22,100	16,600	14,100	10,700	10,100	7700	7600	5800	5900	4500	5500	4100
	All stabilizers down	*28,500	*28,500	*22,300	22,300	*18,400	15,500	14,300	11,700	11,200	9200	10,400	8500
10.0 ft	All stabilizers up	20,400	15,100	13,300	10,000	9600	7300	7400	5500	5800	4400	5200	3900
	All stabilizers down	*31,400	*31,400	*23,500	21,400	18,700	15,100	14,000	11,500	11,100	9100	10,000	8200
5.0 ft	All stabilizers up	18,800	13,600	12,500	9300	9200	6900	7100	5300	5700	4200	5100	3800
	All stabilizers down	*32,600	*32,600	*24,000	20,500	18,200	14,600	13,800	11,200	11,000	9000	9800	8000
0.0 ft	All stabilizers up	17,800	12,600	11,900	8700	8900	6500	6900	5100	5600	4100		
	All stabilizers down	*23,900	*23,900	*22,900	19,800	17,700	14,200	13,500	11,000	*10,600	8900		
-5.0 ft	All stabilizers up					11,600	8400	8600	6300				
	All stabilizers down					*19,800	19,400	*15,600	14,000				

Undercarriage Special Application	Undercarriage configuration	15.0 ft		20.0 ft		25.0 ft		30.0 ft		35.0 ft		ft	
35.0 ft	All stabilizers up					14,200	10,800					10,700	8000
	All stabilizers down					*18,800	*18,800					*13,900	*13,900
30.0 ft	All stabilizers up					14,400	11,000	9800	7400			7600	5700
	All stabilizers down					*19,700	*19,700	*17,000	15,400			*12,400	12,100
25.0 ft	All stabilizers up					14,400	10,900	9900	7500	7100	5300	6200	4500
	All stabilizers down					*19,800	*19,800	*16,900	15,400	13,900	11,300	*11,600	9800
20.0 ft	All stabilizers up					14,000	10,600	9700	7300	7000	5200	5300	3800
	All stabilizers down					*20,500	*20,500	*17,100	15,200	13,800	11,200	10,700	8600
15.0 ft	All stabilizers up	21,300	15,800	13,300	10,000	9300	6900	6900	5000	5200	3700	4800	3400
	All stabilizers down	*27,900	*27,900	*21,600	21,500	*17,600	14,800	13,600	11,000	10,500	8500	9800	7900
10.0 ft	All stabilizers up	19,500	14,100	12,500	9200	8800	6500	6600	4800	5100	3600	4500	3200
	All stabilizers down	*30,600	*30,600	*22,700	20,500	17,900	14,300	13,300	10,700	10,400	8300	9300	7500
5.0 ft	All stabilizers up	17,700	12,500	11,600	8400	8400	6000	6300	4500	5000	3500	4400	3100
	All stabilizers down	*31,500	*31,500	*23,000	19,600	17,300	13,800	13,000	10,400	10,200	8200	*9000	7400
0.0 ft	All stabilizers up	16,700	11,600	11,000	7800	8000	5700	6100	4300	4800	3400		
	All stabilizers down	*22,600	*22,600	*21,700	18,800	*16,800	13,400	12,700	10,200	*9500	8100		
-5.0 ft	All stabilizers up					10,700	7500	7800	5500				
	All stabilizers down					*18,500	18,400	*14,400	13,100				

\*Limited by hydraulic rather than tipping load.

Lift capacity ratings are based on ISO 10567:2007, they do not exceed 87% of hydraulic lifting capacity or 75% of tipping load. The load point is the center line of the bucket pivot mounting pin on the stick. The oscillating axle must be locked. Lifting capacities are based on the machine standing on a firm uniform supporting surface. For lifting capacity including bucket and/or quick coupler, the respective weight has to be subtracted from above values. The use of a work tool attachment point to handle/lift objects, could affect the machine lift performance.

Always refer to the appropriate Operation and Maintenance Manual for specific product information.

● M325D MH ● M325D LMH  
(Ireland Sourced)

Material Handlers

Model	M325D MH		M325D LMH	
Horsepower (ISO 9249 Net) (LRC countries)	140 kW	190 hp	140 kW	190 hp
Horsepower (ISO 9249 Net) (NACD)	140 kW	190 hp	152 kW	204 hp
No. of Tires	8 (4 Duals)		4 Single	
Tire Size	12.00-20 dual solid rubber		16.00-25 single solid rubber	
Maximum Travel Speed	20 km/h	12.4 mph	18 km/h	11 mph
Hydraulic Cab Riser Maximum Height	2.6 m	8'6"	2.6 m	8'6"

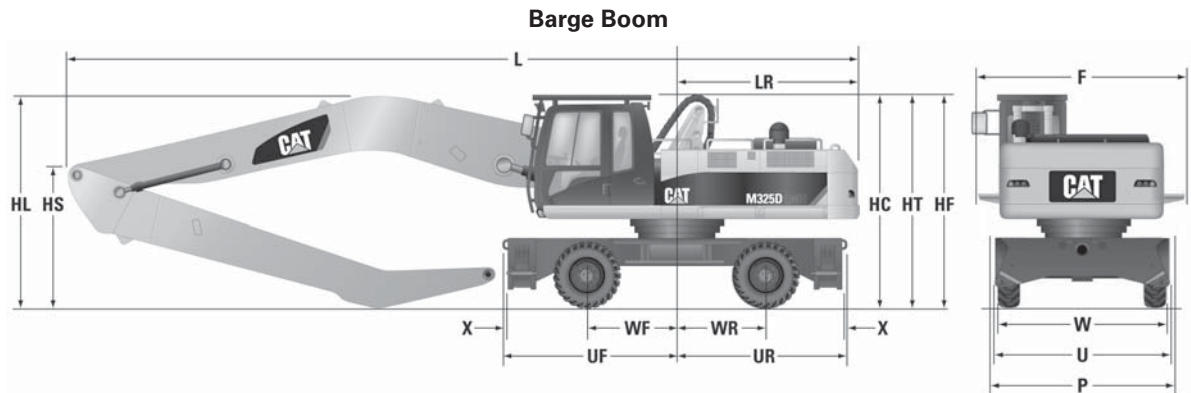

		M325D MH						M325D LMH					
	Boom	Scrap Boom 9.3 m			Barge Boom 9.9 m			Scrap Boom 9.3 m			Barge Boom 9.9 m		
	Stick	7str	5.7 MH	7.1 MH	7str	5.7 MH	7.1 MH	7str	5.7 MH	7.1 MH	7str	5.7 MH	7.1 MH <sup>(1)</sup>
Shipping Weight (Boom + Stick installed) approximate	[t]	33	32.5	32.5	33.5	33	33	37	36.5	36.5	37.5	37	37
Tail Swing Radius (center SBRG – CTWT)	LR [m]	3.02	3.02	3.02	3.02	3.02	3.02	3.03	3.03	3.03	3.03	3.03	3.03 <sup>(1)</sup>
Overall Length (linkage – CTWT)	L [m]	12.6	12.7	12.6	13.3	13.3	13.3	12.7	12.7	12.7	13.2	13.2	13.2 <sup>(1)</sup>
Linkage Height (including lines)	HL [m]	3.5	3.0	3.4	3.3	3.5	3.5	3.4	3.0	3.3	3.4	3.6	3.6 <sup>(1)</sup>
Linkage Height (without lines)	HS [m]	3.4	2.9	3.3	3.3	3.5	3.5	3.3	3.0	3.2	3.4	3.6	3.6 <sup>(1)</sup>
Width Upperframe (without Walkway and Platform)	F [m]	2.95						2.95					
Cab Height with FOGS	HF [m]	3.49 <sup>(2)</sup>			3.47 <sup>(3)</sup>			3.73 <sup>(4)</sup>			3.78 <sup>(5)</sup>		
Cab Height without FOGS	HC [m]	3.36 <sup>(2)</sup>			3.34 <sup>(3)</sup>			3.60 <sup>(4)</sup>			3.65 <sup>(5)</sup>		
HCR Tower Height	HT [m]	3.47 <sup>(2)</sup>			3.45 <sup>(3)</sup>			3.71 <sup>(4)</sup>			3.76 <sup>(5)</sup>		
Width Stabilizer Pads	P [m]	3.28						3.24					
Width Undercarriage	U [m]	2.99						2.99					
Width Wheels	W [m]	2.93 <sup>(2)</sup>			2.95 <sup>(3)</sup>			3.00 <sup>(4)</sup>			3.18 <sup>(5)</sup>		
Wheelbase (Front)	WF [m]	1.50						1.68					
Wheelbase (Rear)	WR [m]	1.50						1.53					
Undercarriage Length (Front)	UF [m]	2.91						3.21					
Undercarriage Length (Rear)	UR [m]	2.91						3.03					
	X [m]	0.13						0.13					

<sup>(1)</sup> = Transportation ONLY OVER REAR (over front stick will touch undercarriage)

<sup>(2)</sup> = 12.00-20 Dual Tires (Standard)

<sup>(3)</sup> = 11.00-20 Dual Tires

<sup>(4)</sup> = 16.0-25 Single Tires (Standard)

<sup>(5)</sup> = 23.5-R25 Michelin Tires

## Material Handlers

## Dimensions

- M325D MH ● M325D LMH
- (Ireland Sourced)

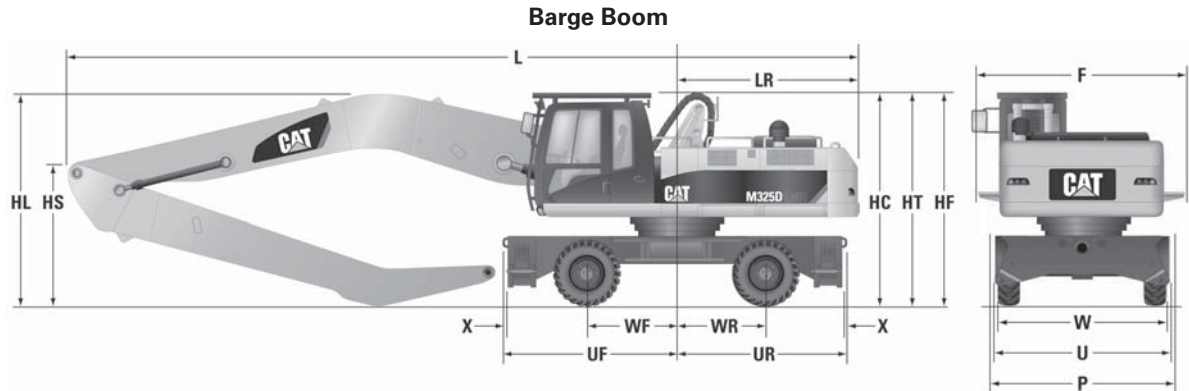

### M325D MH

### M325D LMH

	Boom	Scrap Boom 30'6"			Barge Boom 32'6"			Scrap Boom 30'6"			Barge Boom 32'6"		
<i>Straight Stick 23'0"/&gt; Short MH 18'8"/&gt; Long MH 23'4"</i>	Stick	23'0" str	18'8" MH	23'4" MH	23'0" str	18'8" MH	23'4" MH	23'0" str	18'8" MH	23'4" MH	23'0" str	18'8" MH	23'4" MH <sup>(1)</sup>
Shipping Weight (Boom + Stick installed) approximate	[lb]	72,752	71,650	71,650	73,854	72,752	72,752	81,571	80,468	80,468	82,673	81,571	81,571
Tail Swing Radius (center SBRG – CTWT)	LR [ft]	9'11"	9'11"	9'11"	9'11"	9'11"	9'11"	9'11"	9'11"	9'11"	9'11"	9'11"	9'11" <sup>(1)</sup>
Overall Length (linkage – CTWT)	L [ft]	41'4"	41'8"	41'4"	43'8"	43'8"	43'8"	41'8"	41'8"	41'8"	43'4"	43'4"	43'4" <sup>(1)</sup>
Linkage Height (including lines)	HL [ft]	11'6"	9'10"	11'2"	10'10"	11'6"	11'6"	11'2"	9'10"	10'10"	11'2"	11'10"	11'10" <sup>(1)</sup>
Linkage Height (without lines)	HS [ft]	11'2"	9'6"	10'10"	10'10"	11'6"	11'6"	10'10"	9'10"	10'6"	11'2"	11'10"	11'10" <sup>(1)</sup>
Width Upperframe (without Walkway and Platform)	F [ft]	9'8"						9'8"					
Cab Height with FOGS	HF [ft]	11'5" <sup>(2)</sup>			11'5" <sup>(3)</sup>			12'3" <sup>(4)</sup>			12'5" <sup>(5)</sup>		
Cab Height without FOGS	HC [ft]	11'0" <sup>(2)</sup>			11'0" <sup>(3)</sup>			11'10" <sup>(4)</sup>			12'0" <sup>(5)</sup>		
HCR Tower Height	HT [ft]	11'5" <sup>(2)</sup>			11'4" <sup>(3)</sup>			12'2" <sup>(4)</sup>			12'4" <sup>(5)</sup>		
Width Stabilizer Pads	P [ft]	10'9"						10'8"					
Width Undercarriage	U [ft]	9'10"						9'10"					
Width Wheels	W [ft]	9'7" <sup>(2)</sup>			9'8" <sup>(3)</sup>			9'10" <sup>(4)</sup>			10'5" <sup>(5)</sup>		
Wheelbase (Front)	WF [ft]	4'11"						5'6"					
Wheelbase (Rear)	WR [ft]	4'11"						5'0"					
Undercarriage Length (Front)	UF [ft]	9'7"						10'6"					
Undercarriage Length (Rear)	UR [ft]	9'7"						9'11"					
	X [ft]	5"						5"					

<sup>(1)</sup> = Transportation ONLY OVER REAR (over front stick will touch undercarriage)

<sup>(2)</sup> = 12.00-20 Dual Tires (Standard)

<sup>(3)</sup> = 11.00-20 Dual Tires

<sup>(4)</sup> = 16.0-25 Single Tires (Standard)

<sup>(5)</sup> = 23.5-R25 Michelin Tires

**M325D MH Working Range**

- Maximum Reach 14.4 m (47'3") or 15.5 m (50'10")

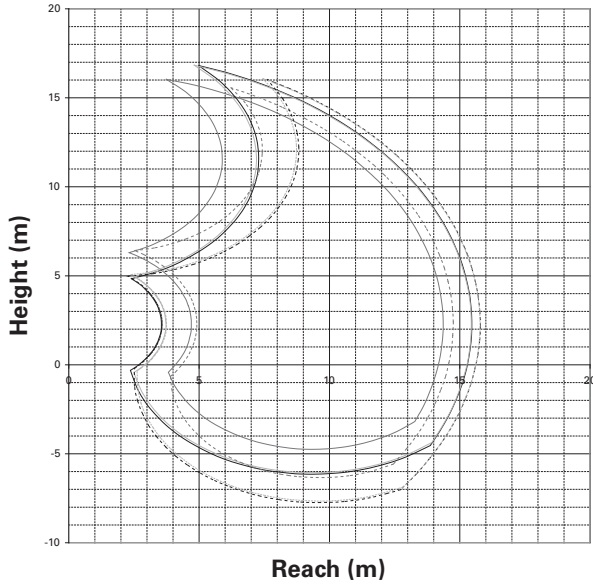

- Boom 9.3 m (30'6"), Stick 5.7 m (18'8")
- Boom 9.3 m (30'6"), Stick 7.1 m (23'4")
- Boom 9.3 m (30'6"), Straight 7.0 m (23'0")
- - - Barge Boom 9.9 m (32'6"), Stick 5.7 m (18'8")
- - - Barge Boom 9.9 m (32'6"), Stick 7.1 m (23'4")
- - - Barge Boom 9.9 m (32'6"), Straight 7.0 m (23'0")

**M325D LMH Working Range**

- Maximum Reach 14.4 m (47'3") or 15.5 m (50'10")

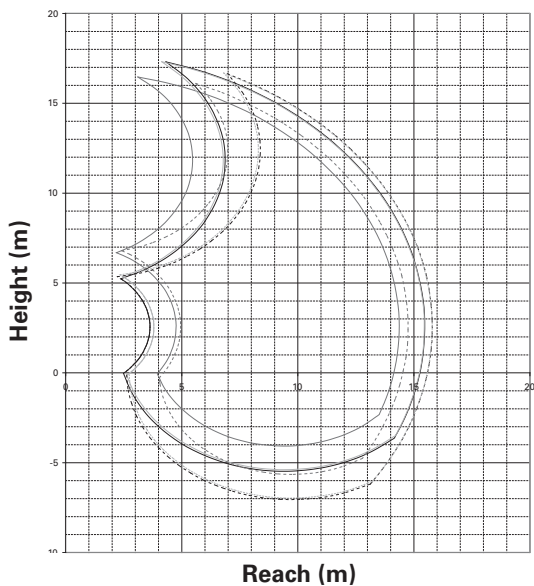

# Material Handlers

## Lifting Capacities

- M325D MH  
(Ireland Sourced)

### M325D MH — Lift Capacities — 5700 mm/18'8"

With 9300 mm/30'6" boom and 5700 mm/18'8" MH stick.

**BOOM** — 9300 mm    **STICK** — 5700 mm    **COUNTERWEIGHT** — 5800 kg

Metric Units/all weights are in kg

Radius of lift point (center line of the bucket pivot mounting pin) from Swing bearing (m)

Undercarriage configuration	3.0 m		4.5 m		6.0 m		7.5 m		9.0 m		10.5 m		12.0 m		13.5 m		m		
15.0 m					*6150	*6150											*5600	*5600	6.47
ER Stabilizers up					*6150	*6150											*5600	*5600	
ER Stabilizers down																			
12.0 m					*8400	8000	7250	5550	5300	4000	3950	2900					3950	2900	10.52
ER Stabilizers up					*8400	*8400	*7650	*7650	*6500	*6500	*4500	*4500					*4450	*4450	
ER Stabilizers down																			
9.0 m					*9200	7700	7050	5350	5200	3900	3950	2950	3100	2200			2750	1950	12.68
ER Stabilizers up					*9200	*9200	*7800	*7800	*6800	*6800	*6050	*6050	*5400	5050			*4150	*4150	
ER Stabilizers down																			
6.0 m	*19 050	*19 050	*13 500	10 400	9000	6650	6350	4700	4750	3500	3700	2650	2950	2100	2350	1600	2200	1500	13.88
ER Stabilizers up	*19 050	*19 050	*13 500	*13 500	*10 350	*10 350	*8450	*8450	*7150	*7150	*6200	6100	*5450	4900	*4750	4000	*4200	3850	
ER Stabilizers down					7300	5100	5400	3800	4200	2950	3350	2300	2700	1850	2200	1500	2000	1300	
3.0 m					*11 450	*11 450	*9000	*9000	*7400	7150	*6250	5700	*5350	4650	*4600	3900	*4100	3500	14.36
ER Stabilizers up																			
ER Stabilizers down																			
0.0 m			*3000	*3000	6350	4150	4750	3150	3750	2500	3000	2000	2500	1650	2100	1400	1950	1250	14.20
ER Stabilizers up			*3000	*3000	*7000	*7000	*8500	*8500	*7000	6650	*5900	5350	*4950	4450	*4050	3750	*3550	3500	
ER Stabilizers down					6200	4050	4550	3000	3550	2350	2900	1900	2450	1600			2150	1400	
-3.0 m					*7300	*7300	*6600	*6600	*5600	*5600	*4700	*4700	*3800	*3800			*2750	*2750	13.38
ER Stabilizers up																			
ER Stabilizers down																			

**BOOM** — 30'6"    **STICK** — 18'8"    **COUNTERWEIGHT** — 12,787 lb

English Units/all weights are in lbs

Radius of lift point (center line of the bucket pivot mounting pin) from Swing bearing (ft)

Undercarriage configuration	10.0 ft		15.0 ft		20.0 ft		25.0 ft		30.0 ft		35.0 ft		40.0 ft		45.0 ft		ft			
50.0 ft			*16,000	*16,000													*12,800	*12,800	19.55	
ER Stabilizers up			*16,000	*16,000													*12,800	*12,800		
ER Stabilizers down																				
40.0 ft					*18,200	17,200	15,500	11,800	11,300	8500							8900	6600	33.89	
ER Stabilizers up					*18,200	*18,200	*16,500	*16,500	*13,600	*13,600							*9900	*9900		
ER Stabilizers down																				
30.0 ft					*19,900	16,700	15,200	11,500	11,200	8400	8500	6300	6600	4700			6100	4300	41.34	
ER Stabilizers up					*19,900	*19,900	*17,000	*17,000	*14,800	*14,800	*13,100	*13,100	*11,100	10,800			*9200	*9200		
ER Stabilizers down																				
20.0 ft	*38,100	*38,100	*29,100	22,500	19,500	14,400	13,700	10,200	10,300	7500	8000	5700	6300	4400	4000	5000	3400	4900	3400	45.44
ER Stabilizers up	*38,100	*38,100	*29,100	*29,100	*22,400	*22,400	*18,300	*18,300	*15,500	*15,500	*13,400	13,100	*11,800	10,500	*10,100	8600	*9200	8500		
ER Stabilizers down					15,800	11,000	11,700	8200	9000	6300	7200	5000	5800	4000	4800	3200	4400	2900		
10.0 ft					*24,800	*24,800	*19,500	*19,500	*16,000	15,400	*13,600	12,300	*11,600	10,000	*9800	8400	*9000	7800	47.11	
ER Stabilizers up																				
ER Stabilizers down																				
0.0 ft			*6900	*6900	13,700	9000	10,200	6800	8000	5400	6500	4400	5400	3600	4500	3000	4300	2800	46.59	
ER Stabilizers up			*6900	*6900	*16,300	*16,300	*18,400	*18,400	*15,200	14,300	*12,700	11,500	*10,600	9600	*8600	8100	*7800	7700		
ER Stabilizers down					13,400	8700	9800	6400	7700	5000	6300	4100	5300	3400			4700	3100		
-10.0 ft					*16,200	*16,200	*14,200	*14,200	*12,100	*12,100	*10,100	*10,100	*8,000	*8,000			*6100	*6100	43.83	
ER Stabilizers up																				
ER Stabilizers down																				

\*Indicates that the load is limited by hydraulic lifting capacity rather than tipping load.

Oscillating axle needs to be locked. Weight of all lifting accessories must be subtracted from the lifting capacities. All lift capacities calculated and rated per ISO 10567:2007. Rated loads do not exceed 87% of hydraulic lift capacity or 75% of tipping load. Lifting capacities are based on the machine standing on a firm uniform supporting surface. The load point is the center line of the bucket pivot mounting pin on the stick. The use of a work tool attachment point to handle/lift objects, could affect the machine lift performance.

All lifts with heavy lift on. Always refer to the appropriate Operation and Maintenance Manual for specific product information.

**M325D MH — Lift Capacities — 7100 mm/23'3"**

With 9300 mm/30'6" boom and 7100 mm/23'3" MH stick.

**BOOM — 9300 mm    STICK — 7100 mm    COUNTERWEIGHT — 5800 kg**

**Metric Units/all weights are in kg**

**Radius of lift point (center line of the bucket pivot mounting pin) from Swing bearing (m)**

Reach (m)	Undercarriage configuration	3.0 m		4.5 m		6.0 m		7.5 m		9.0 m		10.5 m		12.0 m		13.5 m		15.0 m		m				
		ER up	ER down	ER up	ER down	ER up	ER down	ER up	ER down	ER up	ER down	ER up	ER down	ER up	ER down	ER up	ER down	ER up	ER down					
15.0 m	ER Stabilizers up ER Stabilizers down							*4900 *4900	*4900 *4900											*3900 *3900	*3900 *3900	8.66		
12.0 m	ER Stabilizers up ER Stabilizers down							*6400 *6400	*5950 *6400	5600 *5800	4300 *5800	4250 *4850	3200								*3250 *3350	*2350 *3350	11.98	
9.0 m	ER Stabilizers up ER Stabilizers down							*7100 *7100	5750 *6300	5500 *5650	4200 *6300	4200 *5650	3150	3250	2350	2550	1800				2350 *3200	1650 *3200	13.92	
6.0 m	ER Stabilizers up ER Stabilizers down					*9350 *9350	7350 *9350	6800 *7800	5100 *7800	5050 *6700	3750 *6700	3850 *6900	2850 *5900	3050 *6200	2200	2450	1700	1950	1300	1950	1300	1950 *3250	1300 *3250	15.02
3.0 m	ER Stabilizers up ER Stabilizers down			12 150 *14 850	8400 *14 850	7950 *10 900	5650 *10 900	5750 *8650	4100 *8650	4350 *7150	3100 *7150	3450 *6100	2400	2750	1900	2250	1500	1850	1200	1750	1100	1750 *3450	1100 *3150	15.47
0.0 m	ER Stabilizers up ER Stabilizers down	*2000 *2000	*2000 *2000	*4350 *4350	*4350 *4350	6500 *10 100	4300 *10 100	4800 *8700	3250 *7150	3750 *2550	3050 *6000	2000	2500	1650	2050	1300	1750	1100	1650	1050	1650 *3350	1050 *3100	15.32	
-3.0 m	ER Stabilizers up ER Stabilizers down			*4650 *4650	*4650 *4650	6000 *7400	3850 *7400	4400 *7500	2850 *7500	3450 *6250	2200 *6250	2800 *5200	1800	2300	1450	1950	1250				1750 *2800	1100 *2800	14.55	
-6.0 m	ER Stabilizers up ER Stabilizers down									3400 *4200	2200 *4200	2800 *3450	1800	5100	4350	4250	*3500	*3500						

**BOOM — 30'6"    STICK — 23'3"    COUNTERWEIGHT — 12,787 lb**

**English Units/all weights are in lbs**

**Radius of lift point (center line of the bucket pivot mounting pin) from Swing bearing (ft)**

Reach (ft)	Undercarriage configuration	10.0 ft		15.0 ft		20.0 ft		25.0 ft		30.0 ft		35.0 ft		40.0 ft		45.0 ft		50.0 ft		ft				
		ER up	ER down	ER up	ER down	ER up	ER down	ER up	ER down	ER up	ER down	ER up	ER down	ER up	ER down	ER up	ER down	ER up	ER down					
50.0 ft	ER Stabilizers up ER Stabilizers down							*10,200 *10,200	*10,200 *10,200												*8800 *8800	*8800 *8800	27.20	
40.0 ft	ER Stabilizers up ER Stabilizers down							*13,900 *13,900	12,800 *13,900	12,000 *12,400	9200 *12,400	9100 *10,100	6800								7300 *7400	5400 *7400	38.78	
30.0 ft	ER Stabilizers up ER Stabilizers down							*15,500 *15,500	12,400 *13,700	11,800 *13,700	9000 *12,300	9000 *12,300	6700	6900	5100	5400	3800				5300 *7100	3700 *7100	45.44	
20.0 ft	ER Stabilizers up ER Stabilizers down					*20,300 *20,300	15,900 *17,000	14,700 *17,000	11,000 *17,000	10,900 *14,600	8100 *14,600	8300 *12,800	6100	6500	4700	5200	3600	3800			4300 *7100	2900 *7100	49.18	
10.0 ft	ER Stabilizers up ER Stabilizers down			26,300 *32,100	18,300 *32,100	17,200 *23,600	12,300 *23,600	12,400 *18,700	8900 *18,700	9400 *15,500	6700 *15,500	7400	5200	5900	4100	4800	3200	3900	2500	3800	2400	3900 *7600	2400 *6900	50.72
0.0 ft	ER Stabilizers up ER Stabilizers down	*4500 *4500	*4500 *4500	*10,000 *10,000	*10,000 *10,000	14,000 *23,700	9300 *23,700	10,400 *18,900	7000 *18,900	8100 *15,500	5600 *14,400	4300	3500	4400	2800	3700	2300	2300	3700	2300	3700 *7400	2300 *6800	50.26	
-10.0 ft	ER Stabilizers up ER Stabilizers down			*10,500 *10,500	*10,500 *10,500	12,900 *16,900	8300 *16,900	9500 *16,200	6100 *16,200	7400 *13,500	4800 *13,500	6000	3900	5000	3200	4200	2600				3900 *6200	2400 *6200	47.70	
-20.0 ft	ER Stabilizers up ER Stabilizers down									7400 *8900	4800 *8900													

\*Indicates that the load is limited by hydraulic lifting capacity rather than tipping load.

Oscillating axle needs to be locked. Weight of all lifting accessories must be subtracted from the lifting capacities. All lift capacities calculated and rated per ISO 10567:2007. Rated loads do not exceed 87% of hydraulic lift capacity or 75% of tipping load. Lifting capacities are based on the machine standing on a firm uniform supporting surface. The load point is the center line of the bucket pivot mounting pin on the stick. The use of a work tool attachment point to handle/lift objects, could affect the machine lift performance.

All lifts with heavy lift on. Always refer to the appropriate Operation and Maintenance Manual for specific product information.



# Material Handlers

## Lifting Capacities

- M325D MH  
(Ireland Sourced)

### M325D MH — Lift Capacities — 7000 mm/22'11"

With 9300 mm/30'6" boom and 7000 mm/22'11" straight stick.

**BOOM** — 9300 mm    **STICK** — 7000 mm    **COUNTERWEIGHT** — 5800 kg

**Metric Units/all weights are in kg**

**Radius of lift point (center line of the bucket pivot mounting pin) from Swing bearing (m)**

Radius (m)	Undercarriage configuration	3.0 m		4.5 m		6.0 m		7.5 m		9.0 m		10.5 m		12.0 m		13.5 m		15.0 m		m		
		ER up	ER down	ER up	ER down	ER up	ER down	ER up	ER down	ER up	ER down	ER up	ER down	ER up	ER down	ER up	ER down	ER up	ER down			
15.0 m	ER Stabilizers up							*4650	*4650											*3650	*3650	8.61
	ER Stabilizers down							*4650	*4650											*3650	*3650	
12.0 m	ER Stabilizers up							*6200	5650	5300	4000	3900	2850							2900	2050	11.95
	ER Stabilizers down							*6200	*6200	*5550	*5550	*4600	*4600							*3050	*3050	
9.0 m	ER Stabilizers up							*6800	5450	5150	3850	3850	2800	2900	2050	1450				2050	1300	13.89
	ER Stabilizers down							*6800	*6800	*6000	*6000	*5300	*5300	*4750	*4750	*3500	*3500			*2900	*2900	
6.0 m	ER Stabilizers up			*9750	*9750	*9100	7000	6450	4750	4700	3400	3550	2500	2700	1850	2100	1350			1600	950	14.99
	ER Stabilizers down			*9750	*9750	*9100	*9100	*7500	*7500	*6350	*6350	*5500	*5500	*4850	4700	*4250	3750			*2950	*2950	
3.0 m	ER Stabilizers up			11 650	7900	7550	5250	5350	3750	4000	2750	3100	2050	2400	1550	1900	1150	1500	850	1400	750	15.44
	ER Stabilizers down			*14 450	*14 450	*10 500	*10 500	*8250	*8250	*6800	*6800	*5700	5450	*4900	4350	*4200	3550	*3550	2950	*3100	2800	
0.0 m	ER Stabilizers up	*1500	*1500	*3850	*3850	6050	3850	4400	2850	3400	2150	2650	1650	2150	1250	1700	1000	1400	750	1350	700	15.29
	ER Stabilizers down	*1500	*1500	*3850	*3850	*9300	*9300	*8250	*8250	*6700	6350	*5550	5000	*4650	4050	*3900	3350	*3100	2850	*2950	2750	
-3.0 m	ER Stabilizers up			*4250	*4250	5550	3400	4000	2450	3050	1850	2450	1450	1950	1100	1600	900			1450	750	14.52
	ER Stabilizers down			*4250	*4250	*7000	*7000	*6950	*6950	*5750	*5750	*4750	4750	*3900	*3900	*3050	*3050			*2400	*2400	
-6.0 m	ER Stabilizers up									3050	1850											
	ER Stabilizers down									*3650	*3650											

**BOOM** — 30'6"    **STICK** — 22'11"    **COUNTERWEIGHT** — 12,787 lb

**English Units/all weights are in lbs**

**Radius of lift point (center line of the bucket pivot mounting pin) from Swing bearing (ft)**

Radius (ft)	Undercarriage configuration	10.0 ft		15.0 ft		20.0 ft		25.0 ft		30.0 ft		35.0 ft		40.0 ft		45.0 ft		50.0 ft		ft		
		ER up	ER down	ER up	ER down	ER up	ER down	ER up	ER down	ER up	ER down	ER up	ER down	ER up	ER down	ER up	ER down	ER up	ER down			
50.0 ft	ER Stabilizers up							*9600	*9600											*8300	*8300	27.03
	ER Stabilizers down							*9600	*9600											*8300	*8300	
40.0 ft	ER Stabilizers up							*13,400	12,100	11,300	8500	8300	6000							6600	4600	38.65
	ER Stabilizers down							*13,400	*13,400	*11,900	*11,900	*9500	*9500							*6800	*6800	
30.0 ft	ER Stabilizers up							*14,800	11,700	11,100	8300	8200	6000	6200	4300	4600	3000			4500	2900	45.31
	ER Stabilizers down							*14,800	*14,800	*13,000	*13,000	*11,600	*11,600	*10,300	*10,300	*6800	*6800			*6400	*6400	
20.0 ft	ER Stabilizers up					*19,600	15,200	13,900	10,300	10,100	7300	7600	5300	5800	3900	4400	2800			3600	2100	49.08
	ER Stabilizers down					*19,600	*19,600	*16,200	*16,200	*13,800	*13,800	*12,000	*12,000	*10,500	10,100	*9200	8100			*6500	*6500	
10.0 ft	ER Stabilizers up			25,200	17,200	16,300	11,400	11,600	8100	8600	5900	6600	4400	5200	3300	4000	2400	3200	1800	3100	1700	50.62
	ER Stabilizers down			*31,300	*31,300	*22,800	*22,800	*17,900	*17,900	*14,700	*14,700	*12,400	11,700	*10,600	9400	*9100	7700	*7600	6300	*6900	6200	
0.0 ft	ER Stabilizers up	*3400	*3400	*8800	13,000	8300	9500	6100	7300	4600	5700	3500	4600	2700	3700	2100	3000	1600	3000	1600	50.16	
	ER Stabilizers down	*3400	*3400	*8800	*8800	*21,900	*21,900	*17,900	*17,900	*14,500	13,600	*12,000	10,800	*10,100	8800	*8400	7200	*6500	6100	*6500	6100	
-10.0 ft	ER Stabilizers up			*9600	*9600	11,900	7300	8600	5200	6600	4000	5200	3100	4200	2400	3500	1900			3200	1700	47.60
	ER Stabilizers down			*9600	*9600	*16,000	*16,000	*15,000	*15,000	*12,400	*12,400	*10,200	*10,200	*8300	*8300	*6400	*6400			*5200	*5200	
-20.0 ft	ER Stabilizers up																					
	ER Stabilizers down																					

\*Indicates that the load is limited by hydraulic lifting capacity rather than tipping load.

Oscillating axle needs to be locked. Weight of all lifting accessories must be subtracted from the lifting capacities. All lift capacities calculated and rated per ISO 10567:2007. Rated loads do not exceed 87% of hydraulic lift capacity or 75% of tipping load. Lifting capacities are based on the machine standing on a firm uniform supporting surface. The load point is the center line of the bucket pivot mounting pin on the stick. The use of a work tool attachment point to handle/lift objects, could affect the machine lift performance.

All lifts with heavy lift on. Always refer to the appropriate Operation and Maintenance Manual for specific product information.

**M325D LMH — Lift Capacities — 5700 mm/18'8"**

With 9900 mm/32'6" barge boom and 5700 mm/18'8" MH stick.

**BOOM** — 9900 mm    **STICK** — 5700 mm    **COUNTERWEIGHT** — 7700 kg

**Metric Units/all weights are in kg**  
**Radius of lift point (center line of the bucket pivot mounting pin) from Swing bearing (m)**

Lift Configuration	4.5 m		6.0 m		7.5 m		9.0 m		10.5 m		12.0 m		13.5 m		m		
	ER Stabilizers up	ER Stabilizers down	ER Stabilizers up	ER Stabilizers down	ER Stabilizers up	ER Stabilizers down	ER Stabilizers up	ER Stabilizers down	ER Stabilizers up	ER Stabilizers down	ER Stabilizers up	ER Stabilizers down	ER Stabilizers up	ER Stabilizers down	ER Stabilizers up	ER Stabilizers down	
15.0 m					6000	6000									5550	5550	7.78
13.5 m					7700	7500	6350	5500							5050	4700	9.81
12.0 m					7650	7550	6900	5550	5600	4200					4800	3650	11.29
10.5 m					7750	7450	6950	5500	5600	4200	4400	3250			4700	3000	12.41
9.0 m			9400	9400	8050	7200	7100	5350	5500	4100	4350	3200			3600	2600	13.26
7.5 m			10 200	9600	8500	6800	6800	5100	5350	3950	4250	3100	3450	2450	3250	2300	13.90
6.0 m			11 200	8700	8550	6300	6500	4750	5100	3750	4150	3000	3400	2400	3000	2100	14.36
4.5 m			10 850	7700	7950	5700	6100	4400	4900	3500	4000	2850	3300	2300	2850	1950	14.64
3.0 m			9850	6800	7350	5200	5750	4100	4650	3300	3800	2700	3200	2200	2750	1900	14.77
1.5 m			7600	6200	6900	4750	5450	3800	4450	3100	3700	2550	3100	2100	2700	1850	14.74
0.0 m	3450	3450	6950	5900	6600	4500	5250	3550	4250	2900	3550	2450	3000	2050	2700	1850	14.55
-1.5 m	4650	4650	7300	5800	6450	4350	5100	3450	4150	2800	3500	2350	3000	2000	2800	1850	14.21
-3.0 m			7900	5800	6400	4300	5050	3400	4100	2750	3450	2350	2950	2000	2900	1950	13.69
-4.5 m					6450	4350	5050	3400	4100	2800	3450	2350			3150	2150	12.97

Oscillating axle needs to be locked. Weight of all lifting accessories must be subtracted from the lifting capacities. All lift capacities calculated and rated per ISO 10567:2007. Rated loads do not exceed 87% of hydraulic lift capacity or 75% of tipping load. Lifting capacities are based on the machine standing on a firm uniform supporting surface. The load point is the center line of the bucket pivot mounting pin on the stick. The use of a work tool attachment point to handle/lift objects, could affect the machine lift performance.

All lifts with heavy lift on. Always refer to the appropriate Operation and Maintenance Manual for specific product information.

# Material Handlers

## Lifting Capacities ● M325D LMH (Ireland Sourced)

### M325D LMH — Lift Capacities — 5700 mm/18'8"

With 9900 mm/32'6" barge boom and 5700 mm/18'8" MH stick.

**BOOM** — 32'6"

**STICK** — 18'8"

**COUNTERWEIGHT** — 16,976 lb

English Units/all weights are in lbs

Radius of lift point (center line of the bucket pivot mounting pin) from Swing bearing (ft)

Stick Configuration	Undercarriage configuration	15.0 ft		20.0 ft		25.0 ft		30.0 ft		35.0 ft		40.0 ft		45.0 ft		m		
		ER up	ER down	ER up	ER down	ER up	ER down	ER up	ER down	ER up	ER down	ER up	ER down	ER up	ER down	ER up	ER down	
50.0 ft	ER Stabilizers up					13,230	13,230									12,235	12,235	25.52
	ER Stabilizers down					13,230	13,230									12,235	12,235	
45.0 ft	ER Stabilizers up					16,975	16,535	14,000	12,125							11,135	10,360	32.18
	ER Stabilizers down					16,975	16,975	14,000	14,000							11,135	11,135	
40.0 ft	ER Stabilizers up					16,865	16,645	15,210	12,235	12,345	9260					10,580	8045	37.03
	ER Stabilizers down					16,865	16,865	15,210	15,210	13,780	13,780					10,580	10,580	
35.0 ft	ER Stabilizers up					17,085	16,425	15,320	12,125	12,345	9260	9700	7165			9040	6615	40.70
	ER Stabilizers down					17,085	17,085	15,320	15,320	13,890	13,890	12,345	12,345			10,360	10,360	
30.0 ft	ER Stabilizers up			20,725	20,725	17,745	15,875	15,655	11,795	12,125	9040	9590	7055			7935	5730	43.49
	ER Stabilizers down			20,725	20,725	17,745	17,745	15,655	15,655	14,110	14,110	12,785	12,785			10,250	10,250	
25.0 ft	ER Stabilizers up			22,485	21,165	18,740	14,990	14,990	11,245	11,795	8710	9370	6835	7605	5400	7165	5070	45.59
	ER Stabilizers down			22,485	22,485	18,740	18,740	16,315	16,315	14,440	14,440	13,010	13,010	11,795	11,795	10,360	10,360	
20.0 ft	ER Stabilizers up			24,690	19,180	18,850	13,890	14,330	10,470	11,245	8265	9150	6615	7495	5290	6615	4630	47.10
	ER Stabilizers down			24,690	24,690	20,060	20,060	16,975	16,975	14,880	14,880	13,230	13,230	11,795	11,795	10,580	10,580	
15.0 ft	ER Stabilizers up			23,920	16,975	17,525	12,565	13,450	9700	10,800	7715	8820	6285	7275	5070	6285	4300	48.02
	ER Stabilizers down			26,895	26,895	21,275	21,275	17,745	17,745	15,210	15,210	13,340	13,340	11,905	11,685	10,800	10,250	
10.0 ft	ER Stabilizers up			21,715	14,990	16,205	11,465	12,675	9040	10,250	7275	8375	5950	7055	4850	6065	4190	48.45
	ER Stabilizers down			25,575	25,575	22,155	22,155	18,190	18,190	15,540	15,540	13,450	13,450	11,795	11,465	10,470	10,030	
5.0 ft	ER Stabilizers up			16,755	13,670	15,210	10,470	12,015	8375	9810	6835	8155	5620	6835	4630	5950	4080	48.35
	ER Stabilizers down			16,755	16,755	22,265	22,265	18,410	18,410	15,540	15,540	13,450	13,340	11,685	11,245	10,250	9920	
0.0 ft	ER Stabilizers up	7605	7605	15,320	13,005	14,550	9920	11,575	7825	9370	6395	7825	5400	6615	4520	5950	4080	47.72
	ER Stabilizers down	7605	7605	15,320	15,320	21,715	21,715	18,080	18,080	15,320	15,320	13,115	13,115	11,245	11,135	9920	9920	
-5.0 ft	ER Stabilizers up	4650	4650	16,095	12,785	14,220	9590	11,245	7605	9150	6175	7715	5180	6615	4410	6175	4080	46.61
	ER Stabilizers down	4650	4650	16,095	16,095	20,500	20,500	17,195	17,195	14,550	14,550	12,455	12,455	10,470	10,470	9480	9480	
-10.0 ft	ER Stabilizers up			17,415	12,785	14,110	9480	11,135	7495	9040	6065	7605	5180	6505	4410	6395	4300	44.90
	ER Stabilizers down			17,415	17,415	18,520	18,520	15,765	15,765	13,450	13,450	11,355	11,355	9150	9150	8930	8930	
-15.0 ft	ER Stabilizers up			14,220	9590	11,135	7495	9040	6175	7605	5180					6945	4740	42.54
	ER Stabilizers down			15,875	15,875	13,780	13,780	11,685	11,685	9590	9590					8155	8155	

Oscillating axle needs to be locked. Weight of all lifting accessories must be subtracted from the lifting capacities. All lift capacities calculated and rated per ISO 10567:2007. Rated loads do not exceed 87% of hydraulic lift capacity or 75% of tipping load. Lifting capacities are based on the machine standing on a firm uniform supporting surface. The load point is the center line of the bucket pivot mounting pin on the stick. The use of a work tool attachment point to handle/lift objects, could affect the machine lift performance.

All lifts with heavy lift on. Always refer to the appropriate Operation and Maintenance Manual for specific product information.

**M325D LMH — Lift Capacities — 7100 mm/23'3"**

With 9900 mm/32'6" barge boom and 7100 mm/23'3" MH stick.

**BOOM** — 9900 mm    **STICK** — 7100 mm    **COUNTERWEIGHT** — 7700 kg

**Metric Units/all weights are in kg**  
**Radius of lift point (center line of the bucket pivot mounting pin) from Swing bearing (m)**

Lift Height (m)	Undercarriage configuration	3.0 m		4.5 m		6.0 m		7.5 m		9.0 m		10.5 m		12.0 m		13.5 m		15.0 m		Lift Capacity (kg)		m		
		ER Stabilizers up	ER Stabilizers down	ER Stabilizers up	ER Stabilizers down	ER Stabilizers up	ER Stabilizers down	ER Stabilizers up	ER Stabilizers down	ER Stabilizers up	ER Stabilizers down	ER Stabilizers up	ER Stabilizers down	ER Stabilizers up	ER Stabilizers down	ER Stabilizers up	ER Stabilizers down	ER Stabilizers up	ER Stabilizers down	ER Stabilizers up	ER Stabilizers down			
16.5 m	ER Stabilizers up																				4650	4650	7.22	
	ER Stabilizers down																				4650	4650		
15.0 m	ER Stabilizers up									4750	4750											4100	4100	9.62
	ER Stabilizers down									4750	4750											4100	4100	
13.5 m	ER Stabilizers up									6000	5900	4750	4450									3800	3800	11.33
	ER Stabilizers down									6000	6000	4750	4750									3800	3800	
12.0 m	ER Stabilizers up									6200	5900	5750	4500	4500	3450							3700	3100	12.63
	ER Stabilizers down									6200	6200	5750	5750	4500	4500							3700	3700	
10.5 m	ER Stabilizers up									6300	5850	5800	4450	4600	3450	3700	2700					3600	2600	13.63
	ER Stabilizers down									6300	6300	5800	5800	5350	5350	3850	3850					3600	3600	
9.0 m	ER Stabilizers up									6500	5650	5750	4350	4550	3400	3650	2650					3200	2300	14.42
	ER Stabilizers down									6500	6500	5900	5900	5400	5400	5000	5000					3600	3600	
7.5 m	ER Stabilizers up								7700	7300	6800	5400	5550	4150	4450	3250	3600	2600	2900	2050		2900	2050	15.01
	ER Stabilizers down								7700	7700	6800	6800	6100	6100	5500	5500	5050	5050	3650	3650		3650	3650	
6.0 m	ER Stabilizers up			12 600	12 600	9950	9600	8300	6800	6800	6800	5050	5350	3950	4250	3100	3500	2500	2850	2000		2700	1850	15.43
	ER Stabilizers down			12 600	12 600	9950	9950	8300	8300	7150	7150	6300	6300	5650	5650	5100	5100	4600	4600			3750	3750	
4.5 m	ER Stabilizers up			14 850	13 000	11 100	8550	8450	6150	6400	4700	5050	3650	4100	2950	3350	2350	2800	1900		2550	1750	15.69	
	ER Stabilizers down			14 850	14 850	11 100	11 100	8950	8950	7550	7550	6550	6550	5800	5800	5200	5200	4650	4550			3850		3850
3.0 m	ER Stabilizers up			9200	9200	10 600	7450	7750	5550	6000	4300	4750	3400	3900	2750	3200	2250	2700	1850		2450	1650	15.81	
	ER Stabilizers down			9200	9200	12 050	12 050	9500	9500	7900	7900	6750	6750	5900	5900	5250	5250	4650	4450			4000		4000
1.5 m	ER Stabilizers up			5150	5150	9650	6550	7150	5000	5600	3900	4500	3150	3700	2550	3100	2100	2600	1750		2400	1600	15.78	
	ER Stabilizers down			5150	5150	12 600	12 600	9850	9850	8100	8100	6900	6900	5950	5950	5250	5150	4600	4350			4250		4050
0.0 m	ER Stabilizers up	2600	2600	4650	4650	8900	6000	6700	4550	5300	3600	4300	2950	3550	2400	3000	2000	2550	1700		2400	1600	15.61	
	ER Stabilizers down	2600	2600	4650	4650	8900	8900	9900	9900	8150	8150	6900	6900	5950	5950	5150	5000	4450	4300			4150		4050
-1.5 m	ER Stabilizers up	3450	3450	4950	4950	7900	5700	6400	4300	5050	3400	4100	2750	3450	2300	2900	1950	2500	1650		2450	1600	15.29	
	ER Stabilizers down	3450	3450	4950	4950	7900	7900	9650	9650	8000	8000	6750	6750	5800	5800	4950	4900	4200	4200			4050		4050
-3.0 m	ER Stabilizers up			5350	5350	7750	5550	6250	4150	4900	3250	4000	2650	3350	2200	2850	1900					2500	1650	14.81
	ER Stabilizers down			5350	5350	7750	7750	9050	9050	7600	7600	6400	6400	5450	5450	4650	4650					3900	3900	
-4.5 m	ER Stabilizers up			5850	5850	7950	5550	6200	4100	4850	3200	3950	2600	3300	2200	2850	1850					2700	1750	14.15
	ER Stabilizers down			5850	5850	7950	7950	8200	8200	6950	6950	5900	5900	4950	4950	4100	4100					3700	3700	
-6.0 m	ER Stabilizers up					8100	5650	6250	4150	4850	3250	2650	2650	3350	2200							2950	1950	13.29
	ER Stabilizers down					8100	8100	7000	7000	6000	6000	5100	5100	4200	4200							3400	3400	

Oscillating axle needs to be locked. Weight of all lifting accessories must be subtracted from the lifting capacities. All lift capacities calculated and rated per ISO 10567:2007. Rated loads do not exceed 87% of hydraulic lift capacity or 75% of tipping load. Lifting capacities are based on the machine standing on a firm uniform supporting surface. The load point is the center line of the bucket pivot mounting pin on the stick. The use of a work tool attachment point to handle/lift objects, could affect the machine lift performance.

All lifts with heavy lift on. Always refer to the appropriate Operation and Maintenance Manual for specific product information.

# Material Handlers

## Lifting Capacities ● M325D LMH (Ireland Sourced)

### M325D LMH — Lift Capacities — 7100 mm/23'3"

With 9900 mm/32'6" barge boom and 7100 mm/23'3" MH stick.

**BOOM** — 32'6"

**STICK** — 23'3"

**COUNTERWEIGHT** — 16,976 lb

English Units/all weights are in lbs

Radius of lift point (center line of the bucket pivot mounting pin) from Swing bearing (ft)

Stick Length	Undercarriage configuration	10.0 ft		15.0 ft		20.0 ft		25.0 ft		30.0 ft		35.0 ft		40.0 ft		45.0 ft		50.0 ft		m			
		ER Stabilizers up	ER Stabilizers down	ER Stabilizers up	ER Stabilizers down	ER Stabilizers up	ER Stabilizers down	ER Stabilizers up	ER Stabilizers down	ER Stabilizers up	ER Stabilizers down	ER Stabilizers up	ER Stabilizers down	ER Stabilizers up	ER Stabilizers down	ER Stabilizers up	ER Stabilizers down	ER Stabilizers up	ER Stabilizers down	ER Stabilizers up	ER Stabilizers down	ft	m
55.0 ft	ER Stabilizers up																				10,250	10,250	23.68
	ER Stabilizers down																				10,250	10,250	
50.0 ft	ER Stabilizers up									10,470	10,470										9040	9040	31.55
	ER Stabilizers down									10,470	10,470										9040	9040	
45.0 ft	ER Stabilizers up									13,230	13,010	10,470	9810								8380	8380	37.16
	ER Stabilizers down									13,230	13,203	10,470	10,470								8380	8380	
40.0 ft	ER Stabilizers up									13,670	13,010	12,675	9920	9920	7605						6835	6835	41.43
	ER Stabilizers down									13,670	13,670	12,675	12,675	9920	9920						8160	8160	
35.0 ft	ER Stabilizers up									13,890	12,895	12,785	9810	10,140	7605	8160	5950				7940	5730	44.71
	ER Stabilizers down									13,890	13,890	12,785	12,875	11,795	11,795	8490	8490				7940	7940	
30.0 ft	ER Stabilizers up									14,330	12,455	12,675	9590	10,030	7495	8045	5840				7055	5070	47.30
	ER Stabilizers down									14,330	14,330	13,010	13,010	11,905	11,905	11,025	11,025				7940	7940	
25.0 ft	ER Stabilizers up							16,975	16,095	14,990	11,905	12,235	9150	9810	7165	7935	5730	6395	4520	6395	4520	49.23	
	ER Stabilizers down							16,975	16,975	14,990	14,990	13,450	13,450	12,125	12,125	11,135	11,135	8045	8045	8050	8050		
20.0 ft	ER Stabilizers up			27,780	27,780	21,935	21,165	18,300	14,990	14,990	11,135	11,795	8710	9370	6835	7715	5510	6285	4410	5950	4080	50.61	
	ER Stabilizers down			27,780	27,780	21,935	21,935	18,300	18,300	15,760	15,760	13,890	13,890	12,455	12,455	11,245	11,245	10,140	10,140	8270	8270		
15.0 ft	ER Stabilizers up			32,740	28,660	24,470	18,850	18,630	13,560	14,110	10,360	11,135	8045	9040	6505	7385	5180	6170	4190	5620	3860	51.46	
	ER Stabilizers down			32,740	32,740	24,470	24,470	19,730	19,730	16,645	16,645	14,440	14,440	12,785	12,785	11,465	11,465	10,250	10,030	8490	8490		
10.0 ft	ER Stabilizers up			20,280	20,280	23,370	16,425	17,085	12,235	13,230	9480	10,470	7495	8600	6060	7055	4960	5950	4080	5400	3640	51.86	
	ER Stabilizers down			20,280	20,280	26,565	26,565	20,945	20,945	17,415	17,415	14,880	14,880	13,010	13,010	11,575	11,575	10,250	9810	8820	8820		
5.0 ft	ER Stabilizers up			11,355	11,355	21,275	14,440	15,760	11,025	12,345	8600	9920	6945	8160	5620	6835	4630	5730	3860	5290	3530	51.76	
	ER Stabilizers down			11,355	11,355	27,780	27,780	21,715	21,715	17,860	17,860	15,210	15,210	13,120	13,120	11,575	11,355	10,140	9590	9370	8930		
0.0 ft	ER Stabilizers up	5730	5730	10,250	10,250	19,620	13,230	14,770	10,030	11,685	7935	9480	6505	7825	5290	6615	4410	5620	3750	5290	3530	51.20	
	ER Stabilizers down	5730	5730	10,250	10,250	19,620	19,620	21,825	21,825	17,970	17,970	15,210	15,210	13,120	13,120	11,355	11,025	9810	9480	9150	8930		
-5.0 ft	ER Stabilizers up	7605	7605	10,910	10,910	17,415	12,565	14,110	9480	11,135	7495	9040	6060	7605	5070	6395	4300	5510	3640	5400	3530	50.15	
	ER Stabilizers down	7605	7605	10,910	10,910	17,415	17,415	21,275	21,275	17,635	17,635	14,880	14,880	12,785	12,785	10,910	10,800	9260	9260	8930	8930		
-10.0 ft	ER Stabilizers up			11,795	11,795	17,085	12,235	13,780	9150	10,800	7165	8820	5840	7385	4850	6285	4190			5510	3640	48.58	
	ER Stabilizers down			11,795	11,795	17,085	17,085	19,950	19,950	16,755	16,755	14,110	14,110	12,015	12,015	10,250	10,250			8600	8600		
-15.0 ft	ER Stabilizers up			12,895	12,895	17,525	12,235	13,670	9040	10,690	7055	8710	5730	7275	4850	6285	4080			5950	3860	46.41	
	ER Stabilizers down			12,895	12,895	17,525	17,525	18,080	18,080	15,320	15,320	13,010	13,010	10,910	10,910	9040	9040			8160	8160		
-20.0 ft	ER Stabilizers up					17,860	12,455	13,780	9150	10,690	7165	5840	5840	7385	4850					6505	4300	43.59	
	ER Stabilizers down					17,860	17,860	15,430	15,430	13,230	13,230	11,245	11,245	9260	9260					7495	7495		

Oscillating axle needs to be locked. Weight of all lifting accessories must be subtracted from the lifting capacities. All lift capacities calculated and rated per ISO 10567:2007. Rated loads do not exceed 87% of hydraulic lift capacity or 75% of tipping load. Lifting capacities are based on the machine standing on a firm uniform supporting surface. The load point is the center line of the bucket pivot mounting pin on the stick. The use of a work tool attachment point to handle/lift objects, could affect the machine lift performance.

All lifts with heavy lift on. Always refer to the appropriate Operation and Maintenance Manual for specific product information.

**M325D LMH — Lift Capacities — 5700 mm/18'8"**

With 9300 mm/30'6" boom and 5700 mm/18'8" MH stick.

**BOOM — 9300 mm    STICK — 5700 mm    COUNTERWEIGHT — 7700 kg**

**Metric Units/all weights are in kg**

**Radius of lift point (center line of the bucket pivot mounting pin) from Swing bearing (m)**

Undercarriage configuration	4.5 m		6.0 m		7.5 m		9.0 m		10.5 m		12.0 m		13.5 m		m		
15.0 m			*7750	*7750										*6350	*6350	7.01	
12.0 m			*10 100	*10 100	8750	7350	6500	5450	4950	4100					4700	3900	10.78
9.0 m			*10 750	10 150	8500	7100	6350	5300	4950	4100	3900	3200			3450	2800	12.83
6.0 m	*16 100	13 800	10 850	8950	7750	6400	5900	4850	4650	3800	3750	3050	3050	2450	2900	2300	13.96
3.0 m			9150	7300	6800	5500	5300	4300	4250	3450	3500	2800	2950	2350	2650	2100	14.38
0.0 m	*3950	*3950	8250	6450	6150	4850	4850	3850	3950	3150	3300	2650	2800	2250	2650	2100	14.16
-3.0 m			*8550	*8550	10 050	10 050	*8350	*7000	*7000	*5900	*5900	*4800	*4800	*4250	*4250		

**BOOM — 30'6"    STICK — 18'8"    COUNTERWEIGHT — 16,976 lb**

**English Units/all weights are in lbs**

**Radius of lift point (center line of the bucket pivot mounting pin) from Swing bearing (ft)**

Undercarriage configuration	15.0 ft		20.0 ft		25.0 ft		30.0 ft		35.0 ft		40.0 ft		45.0 ft		ft		
50.0 ft	*19,600	*19,600	*16,000	*16,000										*14,500	*14,500	21.49	
40.0 ft			*21,900	*21,900	18,800	15,800	13,900	11,600							10,700	8900	34.81
30.0 ft			*23,300	21,900	18,300	15,400	13,700	11,400	10,600	8800	8400	6900			7700	6300	41.86
20.0 ft	*34,700	29,900	23,500	19,400	16,800	13,900	12,700	10,500	10,000	8200	8100	6600	6600	5300	6400	5100	45.73
10.0 ft			19,800	15,800	14,700	11,900	11,400	9300	9200	7400	7600	6100	6300	5000	5800	4600	47.18
0.0 ft	*9100	*9100	17,800	13,900	13,300	10,500	10,500	8300	8500	6800	7100	5700	6100	4800	5800	4600	46.46
-10.0 ft					12,900	10,200	10,200	8000	8300	6600	7000	5600					

\*Indicates that the load is limited by hydraulic lifting capacity rather than tipping load.

Oscillating axle needs to be locked. Weight of all lifting accessories must be subtracted from the lifting capacities. All lift capacities calculated and rated per ISO 10567:2007. Rated loads do not exceed 87% of hydraulic lift capacity or 75% of tipping load. Lifting capacities are based on the machine standing on a firm uniform supporting surface. The load point is the center line of the bucket pivot mounting pin on the stick. The use of a work tool attachment point to handle/lift objects, could affect the machine lift performance.

All lifts with heavy lift on. Always refer to the appropriate Operation and Maintenance Manual for specific product information.

# Material Handlers

## Lifting Capacities ● M325D LMH (Ireland Sourced)

### M325D LMH — Lift Capacities — 7100 mm/23'3"

With 9300 mm/30'6" boom and 7100 mm/23'3" MH stick.

**BOOM** — 9300 mm    **STICK** — 7100 mm    **COUNTERWEIGHT** — 7700 kg

**Metric Units/all weights are in kg**

**Radius of lift point (center line of the bucket pivot mounting pin) from Swing bearing (m)**

Undercarriage configuration	4.5 m		6.0 m		7.5 m		9.0 m		10.5 m		12.0 m		13.5 m		15.0 m		m			
15.0 m					*6100	*6100	*4650	*4650									*4550	*4550	9.08	
WER Stabilizers up					*6100	*6100	*4650	*4650									*4550	*4550		
WER Stabilizers down																				
12.0 m					*7750	*7750	6850	5750	5250	4400	4100	3400						3950	3250	12.22
WER Stabilizers up					*7750	*7750	*7050	*7050	*6000	*6000	*4300	*4300						*3950	*3950	
WER Stabilizers down																				
9.0 m					*8350	7550	6650	5600	5150	4300	4050	3350	3250	2650				3000	2450	14.06
WER Stabilizers up					*8350	*8350	*7450	*7450	*6700	*6700	*6100	*6100	*4800	*4800				*3800	*3800	
WER Stabilizers down																				
6.0 m	*12 500	*12 500	*11 100	9700	8200	6850	6150	5150	4800	4000	3850	3150	3150	2550	2550	2050	2550	2050	15.09	
WER Stabilizers up	*12 500	*12 500	*11 100	*11 100	*9250	*9250	*8000	*8000	*7000	*7000	*6250	*6250	*5600	5550	*4100	*4100	*3900	*3900		
WER Stabilizers down																				
3.0 m	14 850	11 700	9750	7900	7100	5800	5500	4450	4350	3550	3550	2850	2950	2350	2450	1950	2350	1850	15.48	
WER Stabilizers up	*17 750	*17 750	*13 000	*13 000	*10 300	*10 300	*8550	*8550	*7300	*7300	*6350	*6350	*5550	5350	*4800	4550	*4150	*4150		
WER Stabilizers down																				
0.0 m	*5350	*5350	8350	6550	6200	4900	4900	3900	3950	3150	3300	2600	2750	2150	2350	1850	2300	1800	15.28	
WER Stabilizers up	*5350	*5350	*11 650	*10 400	*10 400	*8550	*8550	*7200	*7200	*6100	*6100	*5200	*5200	*4250	*4250	*4100	*4100			
WER Stabilizers down																				
-3.0 m	*5900	*5900	7900	6100	5800	4550	4550	3600	3750	2950	3150	2450	2700	2100			2450	1900	14.46	
WER Stabilizers up	*5900	*5900	*9150	*9150	*8850	*8850	*7400	*7400	*6200	*6200	*5200	*5200	*4200	*4200			*3450	*3450		
WER Stabilizers down																				

**BOOM** — 30'6"    **STICK** — 23'3"    **COUNTERWEIGHT** — 16,976 lb

**English Units/all weights are in lbs**

**Radius of lift point (center line of the bucket pivot mounting pin) from Swing bearing (ft)**

Undercarriage configuration	15.0 ft		20.0 ft		25.0 ft		30.0 ft		35.0 ft		40.0 ft		45.0 ft		50.0 ft		ft			
50.0 ft			*15,200	*15,200	*12,700	*12,700											*10,200	*10,200	28.64	
WER Stabilizers up			*15,200	*15,200	*12,700	*12,700											*10,200	*10,200		
WER Stabilizers down																				
40.0 ft					*16,800	16,800	14,600	12,400	11,200	9400								8800	7300	39.57
WER Stabilizers up					*16,800	*16,800	*15,100	*15,100	*12,500	*12,500								*8800	*8800	
WER Stabilizers down																				
30.0 ft					*18,200	16,300	14,300	12,100	11,100	9200	8700	7200	7000	5700				6700	5400	45.90
WER Stabilizers up					*18,200	*18,200	*16,200	*16,200	*14,600	*14,600	*13,300	*13,300	*9500	*9500				*8400	*8400	
WER Stabilizers down																				
20.0 ft	*27,100	*27,100	*24,000	21,000	17,700	14,800	13,300	11,100	10,400	8600	8300	6800	6700	5400				5600	4500	49.44
WER Stabilizers up	*27,100	*27,100	*24,000	*24,000	*20,100	*20,100	*17,300	*17,300	*15,200	*15,200	*13,600	*13,600	*12,100	12,000				*8500	*8500	
WER Stabilizers down																				
10.0 ft	32,100	25,300	21,100	17,100	15,400	12,500	11,800	9600	9400	7600	7700	6200	6300	5000	5300	4200	5100	4000	50.79	
WER Stabilizers up	*38,400	*38,400	*28,200	*28,200	*22,400	*22,400	*18,600	*18,600	*15,900	*15,900	*13,800	*13,800	*12,000	11,500	*10,300	9800	*9100	*9100		
WER Stabilizers down																				
0.0 ft	*12,300	*12,300	18,000	14,100	13,400	10,600	10,500	8400	8500	6800	7100	5600	5900	4700	5100	4000	5100	3900	50.13	
WER Stabilizers up	*12,300	*12,300	*27,200	*27,200	*22,500	*22,500	*18,500	*18,500	*15,500	*15,500	*13,200	13,100	*11,200	11,100	*9100	*9100	*9000	*9000		
WER Stabilizers down																				
-10.0 ft	*13,300	*13,300	17,000	13,200	12,600	9800	9900	7700	8100	6300	6700	5300	5800	4500			5400	4200	47.38	
WER Stabilizers up	*13,300	*13,300	*20,900	*20,900	*19,200	*19,200	*16,000	*16,000	*13,400	*13,400	*11,100	*11,100	*8800	*8800			*7600	*7600		
WER Stabilizers down																				

\*Indicates that the load is limited by hydraulic lifting capacity rather than tipping load.

Oscillating axle needs to be locked. Weight of all lifting accessories must be subtracted from the lifting capacities. All lift capacities calculated and rated per ISO 10567:2007. Rated loads do not exceed 87% of hydraulic lift capacity or 75% of tipping load. Lifting capacities are based on the machine standing on a firm uniform supporting surface. The load point is the center line of the bucket pivot mounting pin on the stick. The use of a work tool attachment point to handle/lift objects, could affect the machine lift performance.

All lifts with heavy lift on. Always refer to the appropriate Operation and Maintenance Manual for specific product information.

**M325D LMH — Lift Capacities — 7000 mm/22'11"**

With 9300 mm/30'6" boom and 7000 mm/22'11" straight stick.

**BOOM — 9300 mm      STICK — 7000 mm      COUNTERWEIGHT — 7700 kg**

**Metric Units/all weights are in kg**

**Radius of lift point (center line of the bucket pivot mounting pin) from Swing bearing (m)**

Undercarriage configuration	3.0 m		4.5 m		6.0 m		7.5 m		9.0 m		10.5 m		12.0 m		13.5 m		15.0 m		m
	WER Stabilizers up	WER Stabilizers down	WER Stabilizers up	WER Stabilizers down	WER Stabilizers up	WER Stabilizers down	WER Stabilizers up	WER Stabilizers down	WER Stabilizers up	WER Stabilizers down	WER Stabilizers up	WER Stabilizers down	WER Stabilizers up	WER Stabilizers down	WER Stabilizers up	WER Stabilizers down	WER Stabilizers up	WER Stabilizers down	
15.0 m							*5850	*5850	*4350	*4350							*4300	*4300	9.02
12.0 m							*7550	*7550	*6850	*6850	4900	4050	3750	3050					12.18
9.0 m							*8050	*8050	*7100	*7100	6350	5250	4800	3950	3750	3050	2900	2300	14.03
6.0 m			*12500	*12500	*10800	*10800	7850	6500	5800	4800	4450	3650	3500	2800	2800	2200	2250	1700	15.06
3.0 m			14300	11150	9350	7450	6750	5400	5100	4100	4000	3200	2500	2600	2000	2100	1600	2000	15.45
0.0 m	*2200	*2200	*4800	*4800	7900	6100	5800	4500	4500	3500	3600	2800	2900	2250	2400	1800	2000	1500	15.25
-3.0 m			*5500	*5500	7450	5700	5400	4150	4200	3200	3350	2550	2750	2100	2350	1750			14.43

**BOOM — 30'6"      STICK — 22'11"      COUNTERWEIGHT — 16,976 lb**

**English Units/all weights are in lbs**

**Radius of lift point (center line of the bucket pivot mounting pin) from Swing bearing (ft)**

Undercarriage configuration	10.0 ft		15.0 ft		20.0 ft		25.0 ft		30.0 ft		35.0 ft		40.0 ft		45.0 ft		50.0 ft		ft
	WER Stabilizers up	WER Stabilizers down	WER Stabilizers up	WER Stabilizers down	WER Stabilizers up	WER Stabilizers down	WER Stabilizers up	WER Stabilizers down	WER Stabilizers up	WER Stabilizers down	WER Stabilizers up	WER Stabilizers down	WER Stabilizers up	WER Stabilizers down	WER Stabilizers up	WER Stabilizers down	WER Stabilizers up	WER Stabilizers down	
50.0 ft					*14,700	*14,700	*12,200	*12,200									*9700	*9700	28.48
40.0 ft							*16,300	16,100	13,900	11,600	10,500	8600							39.44
30.0 ft							*17,500	15,600	13,600	11,300	10,300	8500	8000	6500	6200	4900			45.80
20.0 ft			*27,000	*27,000	*23,400	20,200	17,000	14,000	12,500	10,300	9600	7800	7500	6000	6000	4700			49.34
10.0 ft			30,900	24,200	20,200	16,100	14,500	11,700	11,000	8800	8600	6800	6900	5400	5600	4300	4500	3400	50.69
0.0 ft	*5000	*5000	*11,000	*11,000	17,000	13,100	12,500	9700	7500	7700	6000	6300	4800	5200	3900	4300	3200	4300	50.03
-10.0 ft			*12,400	*12,400	16,100	12,200	11,700	8900	9000	6900	7300	5500	6000	4500	5000	3700			47.28

\*Indicates that the load is limited by hydraulic lifting capacity rather than tipping load.

Oscillating axle needs to be locked. Weight of all lifting accessories must be subtracted from the lifting capacities. All lift capacities calculated and rated per ISO 10567:2007. Rated loads do not exceed 87% of hydraulic lift capacity or 75% of tipping load. Lifting capacities are based on the machine standing on a firm uniform supporting surface. The load point is the center line of the bucket pivot mounting pin on the stick. The use of a work tool attachment point to handle/lift objects, could affect the machine lift performance.

All lifts with heavy lift on. Always refer to the appropriate Operation and Maintenance Manual for specific product information.



**MH3022 Specifications**

<b>Model</b>	<b>MH3022</b>	
Operating Weight	22 500-24 500 kg	<b>49,604-54,013 lb</b>
Rated Power (ISO 14396)	129 kW	<b>173 hp</b>
Engine Model	<b>C7.1 ACERT™</b>	
Emissions	<b>U.S. EPA Tier 4 Final, EU Stage IV, Japan 2014 (Tier 4 Final)</b>	
Maximum Travel Speed	25 km/h	<b>15.5 mph</b>
Fuel Tank Refill Capacity	330 L	<b>87.2 U.S. gal</b>
Eye Level Height (Cab Fully Raised)	4850 mm	<b>15'11"</b>
Tail Swing Radius	2570 mm	<b>8'5"</b>

**MH3022 Range Diagram**

- Standard MH Boom — 6400 mm (21'0") and MH Drop Nose Stick — 4900 mm (16'1")

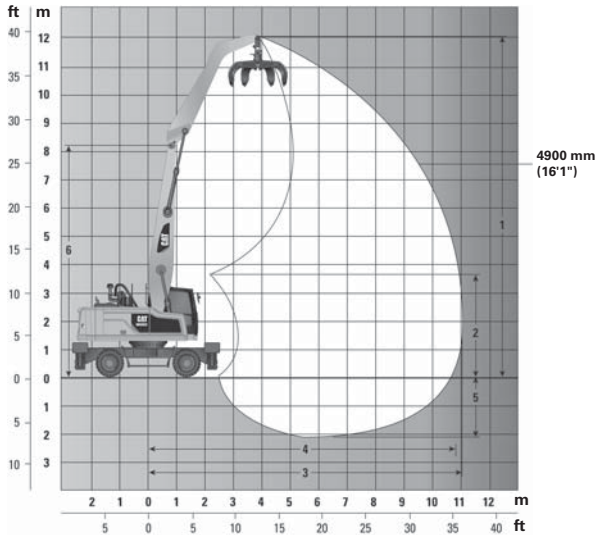

**MH3022 Range Diagram**

- Standard MH Boom — 6400 mm (21'0") and MH Straight Stick — 4200 mm (13'9")

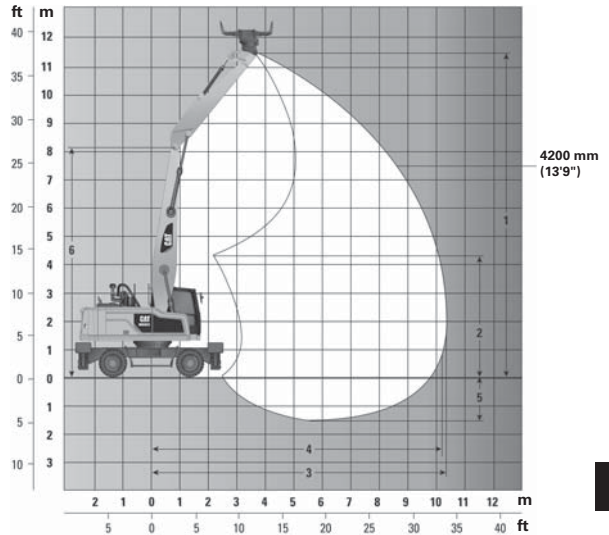

**Undercarriage**

**Special Application MH Undercarriage**

<b>Wheel Base</b>	2750 mm (9'0")			
<b>Width over Tires (10.00-20 Solid)</b>	2700 mm (8'10")			
<b>Boom — Boom Length</b>	Standard MH Boom — 6400 mm (21'0")			
<b>Stick — Stick Length</b>	MH Drop Nose Stick — 4900 mm (16'1")		MH Straight Stick — 4200 mm (13'9")	
<b>1</b> Maximum Vertical Pin Height	12 100 mm	<b>39'8"</b>	11 500 mm	<b>37'9"</b>
<b>2</b> Minimum Dump Height	3550 mm	<b>11'8"</b>	4200 mm	<b>13'9"</b>
<b>3</b> Maximum Horizontal Reach	11 000 mm	<b>36'1"</b>	10 300 mm	<b>33'10"</b>
<b>4</b> Maximum Reach at Ground Level	10 500 mm	<b>34'5"</b>	9800 mm	<b>32'2"</b>
<b>5</b> Maximum Depth	1920 mm	<b>6'3"</b>	1825 mm	<b>5'11"</b>
<b>6</b> Boom Pin Height	8235 mm	<b>27'0"</b>	8235 mm	<b>27'0"</b>

## Material Handlers

### Range Dimensions

- MH3022  
(Grenoble Sourced)

#### MH3022 Range Diagram

- Short MH Boom — 5350 mm (17'7") and  
MH Drop Nose Stick — 4900 mm (16'1")

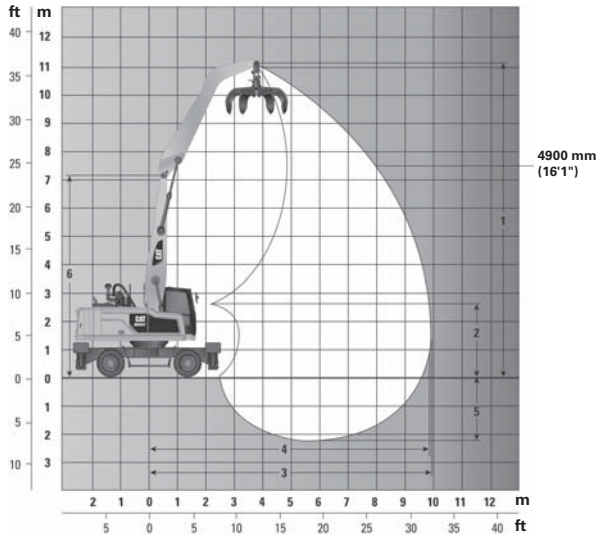

#### MH3022 Range Diagram

- Short MH Boom — 5350 mm (17'7") and  
MH Straight Stick — 4200 mm (13'9")

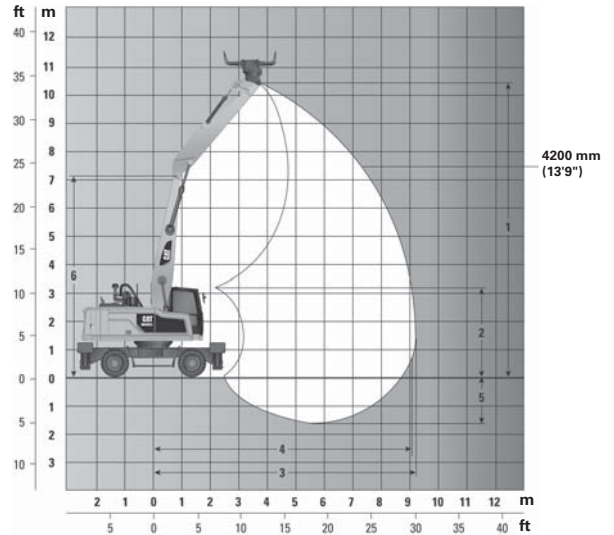

### Undercarriage

	Compact MH Undercarriage			
Wheel Base	2600 mm (8'6")			
Width over Tires (10.00-20 Solid)	2520 mm (8'3")			
Boom — Boom Length	Short MH Boom — 5350 mm (17'7")			
Stick — Stick Length	MH Drop Nose Stick — 4900 mm (16'1")		MH Straight Stick — 4200 mm (13'9")	
<b>1</b> Maximum Vertical Pin Height	11 020 mm	<b>36'2"</b>	10 440 mm	<b>34'3"</b>
<b>2</b> Minimum Dump Height	2635 mm	<b>8'8"</b>	3255 mm	<b>10'8"</b>
<b>3</b> Maximum Horizontal Reach	10 998 mm	<b>36'1"</b>	9330 mm	<b>30'7"</b>
<b>4</b> Maximum Reach at Ground Level	9600 mm	<b>31'6"</b>	8900 mm	<b>29'2"</b>
<b>5</b> Maximum Depth	2324 mm	<b>7'7"</b>	1650 mm	<b>5'5"</b>
<b>6</b> Boom Pin Height	7190 mm	<b>23'7"</b>	7158 mm	<b>23'6"</b>

**Lift Capacities**

All values are in kg, without bucket, with counterweight (4200 kg), heavy lift on.



**Undercarriage**

MH (2.75 m) or MH Narrow (2.55 m)

**Boom**

6.4 m MH

**Stick**

4.9 m MH

Stick height	Undercarriage configuration	3000 mm			4500 mm			6000 mm			7500 mm			9000 mm			10 500 mm			mm		
		SA up	SA down	Narrow up	SA up	SA down	Narrow up	SA up	SA down	Narrow up	SA up	SA down	Narrow up	SA up	SA down	Narrow up	SA up	SA down	Narrow up			
10 500 mm	SA – 2 sets stabilizers up							6250	6250	4750										5200	5200	3950
	SA – 2 sets stabilizers down							*6500	*6500	*6500										*5250	*5250	*5250
	Narrow – 2 sets stabilizers up							5650	5650	4250										4750	4750	3550
	Narrow – 2 sets stabilizers down							*6450	*6450	*6450										*5300	*5300	*5300
9000 mm	SA – 2 sets stabilizers up							6350	6350	4850	4450	4450	3400							3700	3700	2800
	SA – 2 sets stabilizers down							*7850	*7850	*7850	*6300	*6300	*6300							*4700	*4700	*4700
	Narrow – 2 sets stabilizers up							5800	5800	4350	4050	4050	3000							3400	3400	2500
	Narrow – 2 sets stabilizers down							*7850	*7850	7600	*6250	*6250	5300							*4700	*4700	4450
7500 mm	SA – 2 sets stabilizers up							6350	6350	4850	4450	4450	3400	3300	3300	2500				3050	3050	2300
	SA – 2 sets stabilizers down							*8200	*8200	*8200	*7100	*7100	6900	*5500	*5500	5100				*4400	*4400	*4400
	Narrow – 2 sets stabilizers up							5800	5800	4350	4050	4050	3050	3000	3000	2200				2750	2750	2050
	Narrow – 2 sets stabilizers down							*8150	*8150	7600	*7100	*7100	5300	5450	5450	3950				*4400	*4400	3650
6000 mm	SA – 2 sets stabilizers up							6250	6250	4750	4400	4400	3350	3300	3300	2500				2700	2700	2000
	SA – 2 sets stabilizers down							*8400	*8400	*8400	*7200	*7200	6800	*6200	*6200	5100				*4300	*4300	4150
	Narrow – 2 sets stabilizers up							5700	5700	4250	4000	4000	3000	3000	3000	2200				2400	2400	1750
	Narrow – 2 sets stabilizers down							*8400	*8400	7500	*7200	*7200	5250	5450	5450	3900				*4300	*4300	3200
4500 mm	SA – 2 sets stabilizers up				9450	9450	7000	6000	6000	4550	4300	4300	3250	3250	3250	2450	2500	1850		2450	2450	1800
	SA – 2 sets stabilizers down				*11 150	*11 150	*11 150	*8900	*8900	*8900	*7350	*7350	6700	6200	6200	5000	4850	4850	3950	*4300	*4300	3850
	Narrow – 2 sets stabilizers up				8550	8550	6250	5450	5450	4050	3900	3900	2850	2900	2900	2150	2250	1650		2200	2200	1600
	Narrow – 2 sets stabilizers down				*11 150	*11 150	*11 150	*8850	*8850	7250	7150	7150	5100	5350	5350	3850	4200	3000		4100	4100	2950
3000 mm	SA – 2 sets stabilizers up	17 550	17 550	11 900	8800	8800	6450	5700	5700	4250	4100	4100	3100	3150	3150	2350	2500	1850		2350	2350	1700
	SA – 2 sets stabilizers down	*18 550	*18 550	*18 550	*12 350	*12 350	*12 350	*9350	*9350	9250	*7550	*7550	6500	6050	6050	4950	4800	3900		*4400	*4400	3650
	Narrow – 2 sets stabilizers up	15 550	15 550	10 400	7950	7950	5700	5150	5150	3750	3700	3700	2700	2850	2850	2050	2250	1600		2100	2100	1500
	Narrow – 2 sets stabilizers down	*18 500	*18 500	*18 500	*12 350	*12 350	11 000	*9350	*9350	6950	7000	7000	4950	5250	5250	3750	4150	3000		3900	3900	2800
1500 mm	SA – 2 sets stabilizers up				8150	8150	5850	5400	5400	3950	3950	3950	2900	3050	3050	2250	2450	1800		2300	2300	1650
	SA – 2 sets stabilizers down				*13 000	*13 000	*13 000	*9550	*9550	8850	*7500	*7500	6300	5950	5950	4800	*4700	*4700		*4100	*4100	3600
	Narrow – 2 sets stabilizers up				7300	7300	5100	4850	4850	3500	3550	3550	2550	2750	2750	1950	2200	1550		2050	2050	1450
	Narrow – 2 sets stabilizers down				*13 000	*13 000	10 250	*9550	*9550	6600	6800	6800	4750	5150	5150	3650	4100	2950		3850	3850	2750
0 mm	SA – 2 sets stabilizers up	*3500	*3500	*3500	7700	7700	5400	5150	5150	3700	3800	3800	2800	2950	2950	2150	2400	1750				
	SA – 2 sets stabilizers down	*3500	*3500	*3500	*12 200	*12 200	*12 200	*9150	*9150	8600	*7150	*7150	6150	*5550	*5550	4750	*4050	*4050		3800		
	Narrow – 2 sets stabilizers up	*3500	*3500	*3500	6850	6850	4700	4600	4600	3250	3400	3400	2400	2650	2650	1900	2150	1500		1500		
	Narrow – 2 sets stabilizers down	*3500	*3500	*3500	*12 350	*12 350	9750	*9200	*9200	6300	6600	6600	4600	5050	5050	3600	*4050	*4050		2900		
-1500 mm	SA – 2 sets stabilizers up				7450	7450	5200	5000	5000	3600	3700	3700	2700	2900	2900	2100						
	SA – 2 sets stabilizers down				*9600	*9600	*9600	*8000	*8000	*8000	*6200	*6200	6050	*4650	*4650							
	Narrow – 2 sets stabilizers up				6650	6650	4500	4450	4450	3100	3300	3300	2350	2600	2600	1850						
	Narrow – 2 sets stabilizers down				*9600	*9600	9500	*8000	*8000	6150	*6250	*6250	4500	*4700	*4700	3550						

\* Limited by hydraulic rather than tipping load.

Lift capacity ratings are based on ISO 10567:2007, they do not exceed 87% of hydraulic lifting capacity or 75% of tipping load. The load point is the center line of the bucket pivot mounting pin on the stick. The oscillating axle must be locked. Lifting capacities are based on the machine standing on a firm uniform supporting surface. For lifting capacity including bucket and/or quick coupler, the respective weight has to be subtracted from above values. The use of a work tool attachment point to handle/lift objects, could affect the machine lift performance.

Always refer to the appropriate Operation and Maintenance Manual for specific product information.

### Lift Capacities

All values are in lb, without bucket, with counterweight (9260 lb), heavy lift on.

 Load point height    
  Load over front    
  Load over rear    
  Load over side    
  Load at maximum reach (sticknose/bucket pin)

#### Undercarriage

MH (9'0") or MH Narrow (8'4")

#### Boom

21'0" MH

#### Stick

16'1" MH

Stick height	Undercarriage configuration	10 ft			15 ft			20 ft			25 ft			30 ft			35 ft			ft		
		Front	Side	Rear	Front	Side	Rear	Front	Side	Rear	Front	Side	Rear	Front	Side	Rear	Front	Side	Rear			
35 ft	SA – 2 sets stabilizers up							13,100	13,100	10,000										*11,800	*11,800	9000
	SA – 2 sets stabilizers down							*13,400	*13,400	*13,400										*11,800	*11,800	*11,800
	Narrow – 2 sets stabilizers up							11,900	11,900	8900										10,900	10,900	8100
	Narrow – 2 sets stabilizers down							*13,300	*13,300	*13,300										*11,800	*11,800	*11,800
30 ft	SA – 2 sets stabilizers up							13,500	13,500	10,300	9400	9400	7100							8300	8300	6200
	SA – 2 sets stabilizers down							*16,900	*16,900	*16,900	*13,000	*13,000	*13,000							*10,300	*10,300	*10,300
	Narrow – 2 sets stabilizers up							12,300	12,300	9200	8500	8500	6300							7500	7500	5600
	Narrow – 2 sets stabilizers down							*16,900	*16,900	16,100	*12,900	*12,900	11,100							*10,400	*10,400	9900
25 ft	SA – 2 sets stabilizers up							13,500	13,500	10,300	9400	9400	7200	7000	7000	5200				6700	6700	5000
	SA – 2 sets stabilizers down							*17,800	*17,800	*17,800	*15,400	*15,400	14,600	*11,000	*11,000	10,800				*9700	*9700	*9700
	Narrow – 2 sets stabilizers up							12,300	12,300	9200	8600	8600	6400	6300	6300	4600				6100	6100	4400
	Narrow – 2 sets stabilizers down							*17,800	*17,800	16,200	*15,400	*15,400	11,200	*10,900	*10,900	8300				*9700	*9700	8000
20 ft	SA – 2 sets stabilizers up							13,200	13,200	10,100	9300	9300	7100	6900	6900	5200				5800	5800	4300
	SA – 2 sets stabilizers down							*18,300	*18,300	*18,300	*15,600	*15,600	14,500	13,200	13,200	10,800				*9400	*9400	9100
	Narrow – 2 sets stabilizers up							12,100	12,100	9000	8500	8500	6300	6300	6300	4600				5200	5200	3800
	Narrow – 2 sets stabilizers down							*18,300	*18,300	15,900	15,500	15,500	11,100	11,500	11,500	8300				*9400	*9400	7000
15 ft	SA – 2 sets stabilizers up				20,100	20,100	14,900	12,800	12,800	9600	9100	9100	6800	6800	6800	5100				5300	5300	3900
	SA – 2 sets stabilizers down				*24,200	*24,200	*24,200	*19,200	*19,200	*19,200	*15,900	*15,900	14,200	13,100	13,100	10,700				*9400	*9400	8400
	Narrow – 2 sets stabilizers up				18,200	18,200	13,300	11,600	11,600	8600	8200	8200	6100	6200	6200	4500				4800	4800	3400
	Narrow – 2 sets stabilizers down				*24,100	*24,100	*24,100	*19,200	*19,200	15,400	15,200	15,200	10,800	11,400	11,400	8200				8900	8900	6400
10 ft	SA – 2 sets stabilizers up	37,200	37,200	25,400	18,700	18,700	13,700	12,100	12,100	9000	8700	8700	6500	6600	6600	4900	5200	5200	3800	5000	5000	3700
	SA – 2 sets stabilizers down	*40,000	*40,000	*40,000	*26,700	*26,700	*26,700	*20,200	*20,200	19,600	*16,300	*16,300	13,800	12,900	12,900	10,500	10,200	10,200	8300	*9700	*9700	8000
	Narrow – 2 sets stabilizers up	33,000	33,000	22,200	16,900	16,900	12,100	11,000	11,000	8000	7900	7900	5700	6000	6000	4300	4700	4700	3300	4500	4500	3200
	Narrow – 2 sets stabilizers down	*39,900	*39,900	*39,900	*26,700	*26,700	23,400	*20,200	*20,200	14,700	14,800	14,800	10,500	11,200	11,200	8000	8800	8800	6300	8500	8500	6000
5 ft	SA – 2 sets stabilizers up				17,300	17,300	12,400	11,400	11,400	8400	8300	8300	6100	6400	6400	4700	5100	5100	3700	4900	4900	3600
	SA – 2 sets stabilizers down				*28,100	*28,100	*28,100	*20,700	*20,700	18,800	*16,200	*16,200	13,400	12,700	12,700	10,200	*9900	*9900	8200	*9000	*9000	7800
	Narrow – 2 sets stabilizers up				15,500	15,500	10,800	10,300	10,300	7400	7500	7500	5400	5800	5800	4100	4600	4600	3200	4400	4400	3100
	Narrow – 2 sets stabilizers down				*28,100	*28,100	21,800	20,500	20,500	14,000	14,400	14,400	10,100	10,900	10,900	7800	8700	8700	6200	8300	8300	5900
0 ft	SA – 2 sets stabilizers up	*8000	*8000	*8000	16,300	16,300	11,500	10,900	10,900	7900	8000	8000	5900	6300	6300	4600						
	SA – 2 sets stabilizers down	*8000	*8000	*8000	*26,700	*26,700	*26,700	*19,800	*19,800	18,200	*15,400	*15,400	13,000	*11,900	*11,900	10,000						
	Narrow – 2 sets stabilizers up	*8000	*8000	*8000	14,500	14,500	9900	9700	9700	6800	7200	7200	5100	5600	5600	3900						
	Narrow – 2 sets stabilizers down	*8000	*8000	*8000	*26,700	*26,700	20,700	19,800	19,800	13,400	14,100	14,100	9800	10,800	10,800	7600						
-5 ft	SA – 2 sets stabilizers up				15,800	15,800	11,000	10,600	10,600	7600	7800	7800	5700									
	SA – 2 sets stabilizers down				*22,100	*22,100	*22,100	*17,200	*17,200	*17,200	*13,300	*13,300	12,800									
	Narrow – 2 sets stabilizers up				14,000	14,000	9500	9400	9400	6500	7000	7000	4900									
	Narrow – 2 sets stabilizers down				*22,200	*22,200	20,100	*17,300	*17,300	13,100	*13,400	*13,400	9600									

\*Limited by hydraulic rather than tipping load.

Lift capacity ratings are based on ISO 10567:2007, they do not exceed 87% of hydraulic lifting capacity or 75% of tipping load. The load point is the center line of the bucket pivot mounting pin on the stick. The oscillating axle must be locked. Lifting capacities are based on the machine standing on a firm uniform supporting surface. For lifting capacity including bucket and/or quick coupler, the respective weight has to be subtracted from above values. The use of a work tool attachment point to handle/lift objects, could affect the machine lift performance.

Always refer to the appropriate Operation and Maintenance Manual for specific product information.

**Lift Capacities**

All values are in kg, without bucket, with counterweight (4200 kg), heavy lift on.

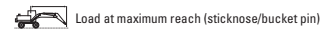
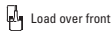

**Undercarriage**

**Boom**  
6.4 m MH

**Stick**  
4.9 m MH

Standard

Stick height	Undercarriage configuration	3000 mm			4500 mm			6000 mm			7500 mm			9000 mm			10 500 mm			mm	
		Load point height	Load over front	Load over rear	Load point height	Load over front	Load over rear	Load point height	Load over front	Load over rear	Load point height	Load over front	Load over rear	Load point height	Load over front	Load over rear	Load point height	Load over front	Load over rear		
10 500 mm	Front stabilizer and rear dozer up							6100			4550								5050	3750	
	Front stabilizer and rear dozer down							*6500	*6500	*6500									*5250	*5250	
	2 sets stabilizers up							6250			4600								5200	3800	
	2 sets stabilizers down							*6500			*6500								*5250	*5250	
	Front dozer and rear stabilizer up							6300			4550								5250	3750	
9000 mm	Front dozer and rear stabilizer down							*6500	*6500	*6500									*5250	*5250	
7500 mm	Front stabilizer and rear dozer up							6250			4650	4350		3250					3600	2700	
	Front stabilizer and rear dozer down							*7850	*7850	*7850	7100	*6300	*6300	4950					*4700	*4700	
	2 sets stabilizers up							6400			4700	4450		3250					3700	2700	
	2 sets stabilizers down							*7850			*7850	*6300		5800					*4700	*4700	
	Front dozer and rear stabilizer up							6450			4650	4500		3250					3750	2700	
6000 mm	Front dozer and rear stabilizer down							*7850	*7850	*7850	7300	*6300	*6300	5050					*4700	*4700	
4500 mm	Front stabilizer and rear dozer up							6250			4650	4350		3250	3200				2950	2200	
	Front stabilizer and rear dozer down							*8200	*8200	*8200	7100	*7100	*7100	4950	*5500	*5500	3700			*4400	*4400
	2 sets stabilizers up							6400			4700	4450		3300	3300				3400	3400	
	2 sets stabilizers down							*8200			*8200	*7100		5850	*5500				3050	2200	
	Front dozer and rear stabilizer up							6450			4650	4500		3250	3300				3050	2200	
3000 mm	Front dozer and rear stabilizer down							*8200	*8200	*8200	7250	*7100	6950	5050	*5500	5150	3750			*4400	*4400
1500 mm	Front stabilizer and rear dozer up							6100			4550	4300		3200	3200				2600	1900	
	Front stabilizer and rear dozer down							*8400	*8400	*8400	7000	*7200	*7200	4900	5900				*4300	*4300	
	2 sets stabilizers up							6300			4600	4400		3250	3300				2650	1900	
	2 sets stabilizers down							*8400			8250	*7200		5750	6050				*4300	*4300	
	Front dozer and rear stabilizer up							6300			4550	4450		3200	3300				2700	1900	
10 680	Front dozer and rear stabilizer down							*8400	*8400	*8400	7150	*7200	6900	5000	*6200	5100	3750			*4700	*4700
10 940	Front stabilizer and rear dozer up							9350			6750	5900		4350	4150				2300	2450	
	Front stabilizer and rear dozer down							*11 150	*11 150	*11 150	10 800	*8900	*8900	6750	*7350	*7350	4800	5800		4500	2800
	2 sets stabilizers up							9600			6050	6050		3100	3250				2350	2500	
	2 sets stabilizers down							*11 150			*11 150	*8900		8050	*7350				4250	4700	
	Front dozer and rear stabilizer up							9650			6750	6100		4350	4300				2300	2550	
10 940	Front dozer and rear stabilizer down							*11 150	*11 150	*11 150	11 100	*8900	*8900	6900	*7350	6750	4850	6200	5050	3650	*4950
3000 mm	Front stabilizer and rear dozer up	17 750		11 400	8700			6150	5600		4050	4000		2950	3050				2200	2400	
	Front stabilizer and rear dozer down	*18 550	*18 550	*18 550	*12 350	*12 350	10 100	*9350	*9350		6450	*7550	7500	4600	5700				3500	4500	
	2 sets stabilizers up	18 200		11 550	8950			6200	5750		4100	4100		2950	3150				2250	2500	
	2 sets stabilizers down	*18 550		*18 550	*12 350			*12 350	*9350		7700	*7550		5450	5900				4150	4650	
	Front dozer and rear stabilizer up	18 300		11 400	9000			6150	5800		4050	4150		2950	3150				2200	2500	
10 940	Front dozer and rear stabilizer down	*18 550	*18 550	*18 550	*12 350	*12 350	10 400	*9350	*9350		6600	*7550	6550	4700	*6200	4950	3600		*5000	3900	
1500 mm	Front stabilizer and rear dozer up							8000			5550	5250		3750	3850				2150	2350	
	Front stabilizer and rear dozer down							*13 000	*13 000		9400	*9550	*9550	6100	7450	7300				3400	4450
	2 sets stabilizers up							8250			5600	5400		3800	3950				2150	2450	
	2 sets stabilizers down							*13 000			11 600	*9550		7350	*7500				4050	4600	
	Front dozer and rear stabilizer up							8300			5550	5450		3750	3950				2150	2450	
11 000	Front dozer and rear stabilizer down							*13 000	*13 000		9700	*9550	9000	6250	*7500	6350	4550		*6050	4850	
0 mm	Front stabilizer and rear dozer up	*3500		*3500	7550			5150	5000		3550	3700		2650	2850				2050	2300	
	Front stabilizer and rear dozer down	*3500	*3500	*3500	*12 200	*12 200	8900	*9150			5850	*7150	7100	4300	5500				3350	*4050	
	2 sets stabilizers up	*3500		*3500	7800			5200	5150		3550	3800		2650	2950				2100	2400	
	2 sets stabilizers down	*3500		*3500	*12 200			11 100	*9150		7050	*7150		5100	*5550				3950	*4050	
	Front dozer and rear stabilizer up	*3500		*3500	7850			5150	5200		3550	3850		2650	3000				2050	2400	
1650	Front dozer and rear stabilizer down	*3500	*3500	*3500	*12 200	*12 200	9200	*9150			6000	*7150	6200	4400	*5550	4750	3400		*4050	3850	
-1500 mm	Front stabilizer and rear dozer up							7350			4950	4850		3400	3600				2550	2800	
	Front stabilizer and rear dozer down							*9600			*9600	*8000		5700	*6200				*4650	3300	
	2 sets stabilizers up							7550			5000	5000		3450	3700				2550	2900	
	2 sets stabilizers down							*9600			*9600	*8000		6900	*6200				5000	*4650	
	Front dozer and rear stabilizer up							7600			4950	5050		3400	3750				2550	2950	
2000	Front dozer and rear stabilizer down							*9600	*9600		8950	*8000	*8000	5850	*6200	6100	4300		*4650	*4650	

\*Limited by hydraulic rather than tipping load.

Lift capacity ratings are based on ISO 10567:2007, they do not exceed 87% of hydraulic lifting capacity or 75% of tipping load. The load point is the center line of the bucket pivot mounting pin on the stick. The oscillating axle must be locked. Lifting capacities are based on the machine standing on a firm uniform supporting surface. For lifting capacity including bucket and/or quick coupler, the respective weight has to be subtracted from above values. The use of a work tool attachment point to handle/lift objects, could affect the machine lift performance.

Always refer to the appropriate Operation and Maintenance Manual for specific product information.

### Lift Capacities

All values are in lb, without bucket, with counterweight (9260 lb), heavy lift on.



#### Undercarriage Standard

#### Boom 21'0" MH

#### Stick 16'1" MH

Stick ft	Undercarriage configuration	10 ft			15 ft			20 ft			25 ft			30 ft			35 ft			ft			
		Load point height	Load over front	Load over rear	Load over front	Load over rear	Load over side	Load over front	Load over rear	Load over side	Load over front	Load over rear	Load over side	Load over front	Load over rear	Load over side	Load over front	Load over rear	Load over side				
35 ft	Front stabilizer and rear dozer up																			11,600	11,100	8600	
	Front stabilizer and rear dozer down																				*11,800	*11,800	*11,800
	2 sets stabilizers up																				*11,800	11,000	8700
	2 sets stabilizers down																				*11,800	*11,800	*11,800
	Front dozer and rear stabilizers up																				*11,800	10,700	8600
	Front dozer and rear stabilizers down																				*11,800	*11,800	*11,800
30 ft	Front stabilizer and rear dozer up																				8000	7700	5900
	Front stabilizer and rear dozer down																				*10,300	*10,300	9000
	2 sets stabilizers up																				8300	7600	6000
	2 sets stabilizers down																				*10,300	*10,300	*10,300
	Front dozer and rear stabilizers up																				8300	7400	5900
	Front dozer and rear stabilizers down																				*10,300	*10,300	9200
25 ft	Front stabilizer and rear dozer up																				6500	6200	4700
	Front stabilizer and rear dozer down																				*9700	*9700	7300
	2 sets stabilizers up																				6700	6200	4800
	2 sets stabilizers down																				*9700	*9700	8800
	Front dozer and rear stabilizers up																				6700	6000	4700
	Front dozer and rear stabilizers down																				*9700	*9700	7400
20 ft	Front stabilizer and rear dozer up																				5600	5400	4100
	Front stabilizer and rear dozer down																				*9400	*9400	6300
	2 sets stabilizers up																				5800	5400	4100
	2 sets stabilizers down																				*9400	*9400	7700
	Front dozer and rear stabilizers up																				5800	5200	4100
	Front dozer and rear stabilizers down																				*9400	*9400	6500
15 ft	Front stabilizer and rear dozer up																				5100	4900	3700
	Front stabilizer and rear dozer down																				*9400	*9400	5800
	2 sets stabilizers up																				5300	4900	3700
	2 sets stabilizers down																				*9400	8600	7000
	Front dozer and rear stabilizers up																				5300	4700	3700
	Front dozer and rear stabilizers down																				*9400	8400	5900
10 ft	Front stabilizer and rear dozer up	37,600	33,700	24,300	18,500	17,300	13,100	11,800	11,200	8600	8100	6200	6400	6100	4700	5000	4800	3600	3600	4800	4600	3400	
	Front stabilizer and rear dozer down	*40,000	*40,000	*40,000	*26,700	*26,700	20,800	*20,200	*20,200	13,300	16,200	15,900	9500	12,100	12,000	7200	9500	9400	5700	9200	9100	5500	
	2 sets stabilizers up	38,600	33,600	24,500	19,000	17,200	13,200	12,200	11,200	8700	8700	8000	6200	6600	6100	4700	5200	4800	3700	5000	4600	3500	
	2 sets stabilizers down	*40,000	*40,000	*40,000	*26,700	*26,700	26,300	*20,200	*20,200	16,300	14,300	11,600	12,500	10,800	8800	8800	6900	6900	6900	9400	8200	6700	
	Front dozer and rear stabilizers up	38,800	32,600	24,300	19,100	16,700	13,100	12,300	10,800	8600	8800	7800	6200	6700	5900	4700	5200	4600	3600	5000	4400	3400	
	Front dozer and rear stabilizers down	*40,000	*40,000	*40,000	*26,700	*26,700	21,600	*20,200	19,900	13,700	*16,300	13,900	9700	*13,400	10,500	7400	*10,700	8300	5800	*9700	8000	5600	
5 ft	Front stabilizer and rear dozer up																				4900	4700	3500
	Front stabilizer and rear dozer down																				*9000	*9000	5400
	2 sets stabilizers up																				4900	4500	3400
	2 sets stabilizers down																				*9000	*9000	6500
	Front dozer and rear stabilizers up																				5100	4500	3500
	Front dozer and rear stabilizers down																				*9000	*9000	4300
0 ft	Front stabilizer and rear dozer up	*8000	*8000	*8000	16,000	14,900	10,900	10,600	10,000	7400	7800	7400	5500	6000	5800	4300							
	Front stabilizer and rear dozer down	*8000	*8000	*8000	*26,700	*26,700	18,300	*19,800	12,000	*15,400	15,100	8800	11,700	11,500	6800								
	2 sets stabilizers up	*8000	*8000	*8000	16,500	14,800	11,000	10,900	10,000	7500	8000	7400	5600	6200	5700	4400							
	2 sets stabilizers down	*8000	*8000	*8000	*26,700	*26,700	23,500	*19,800	19,100	15,000	*15,400	13,600	10,800	*11,900	10,400	8400							
	Front dozer and rear stabilizers up	*8000	*8000	*8000	16,600	14,300	10,900	11,000	9600	7400	8100	7100	5500	6300	5500	4300							
	Front dozer and rear stabilizers down	*8000	*8000	*8000	*26,700	*26,700	18,900	*19,800	18,500	12,400	*15,400	13,200	9000	*11,900	10,100	7000							
-5 ft	Front stabilizer and rear dozer up																						
	Front stabilizer and rear dozer down																						
	2 sets stabilizers up																						
	2 sets stabilizers down																						
	Front dozer and rear stabilizers up																						
	Front dozer and rear stabilizers down																						

\*Limited by hydraulic rather than tipping load.

Lift capacity ratings are based on ISO 10567:2007, they do not exceed 87% of hydraulic lifting capacity or 75% of tipping load. The load point is the center line of the bucket pivot mounting pin on the stick. The oscillating axle must be locked. Lifting capacities are based on the machine standing on a firm uniform supporting surface. For lifting capacity including bucket and/or quick coupler, the respective weight has to be subtracted from above values. The use of a work tool attachment point to handle/lift objects, could affect the machine lift performance.

Always refer to the appropriate Operation and Maintenance Manual for specific product information.

**Lift Capacities**

All values are in kg, bucket cylinder and linkage installed, without bucket, with counterweight (4200 kg), heavy lift on.

 Load point height    
  Load over front    
  Load over rear    
  Load over side    
  Load at maximum reach (sticknose/bucket pin)





















**Undercarriage**

MH (2.75 m) or MH Narrow (2.55 m)

**Boom**  
6.4 m MH

**Stick**

4.2 m Straight Stick

	Undercarriage configuration	3000 mm			4500 mm			6000 mm			7500 mm			9000 mm						mm			
																							
9000 mm	SA – 2 sets stabilizers up							5900	5900	4400								4050	4050	3000	7420		
	SA – 2 sets stabilizers down							*8100	*8100	*8100								*5300	*5300	*5300			
	Narrow – 2 sets stabilizers up							5350	5350	3900								3700	3700	2650			
	Narrow – 2 sets stabilizers down							*8050	*8050	7150								*5300	*5300	4950			
7500 mm	SA – 2 sets stabilizers up							5900	5900	4400	4050	4050	3000					3150	3150	2250	8640		
	SA – 2 sets stabilizers down							*8250	*8250	*8250	*7000	*7000	6450					*4900	*4900	*4900			
	Narrow – 2 sets stabilizers up							5350	5350	3950	3650	3650	2650					2800	2800	2000			
	Narrow – 2 sets stabilizers down							*8250	*8250	7150	6950	6950	4900					*4900	*4900	3800			
6000 mm	SA – 2 sets stabilizers up							9350	9350	6900	5800	5800	4300	4000	4000	2950	2900	2900	2100	2650	2650	1900	9460
	SA – 2 sets stabilizers down							*10 600	*10 600	*10 600	*8500	*8500	*8500	*7050	*7050	6400	5850	5850	4700	*4750	*4750	4300	
	Narrow – 2 sets stabilizers up							8450	8450	6100	5250	5250	3800	3600	3600	2600	2600	2600	1800	2350	2350	1650	
	Narrow – 2 sets stabilizers down							*10 600	*10 600	*10 600	*8450	*8450	7050	6900	6900	4850	5050	5050	3550	4600	4600	3250	
4500 mm	SA – 2 sets stabilizers up	*14 500	*14 500	12 500	8850	8850	6450	5550	5550	4100	3900	3900	2850	2850	2850	2050	2350	2350	1650				10 000
	SA – 2 sets stabilizers down	*14 500	*14 500	*14 500	*11 500	*11 500	*11 500	*8850	*8850	*8850	*7150	*7150	6250	5800	5800	4650	*4750	*4750	3900				
	Narrow – 2 sets stabilizers up	*14 250	*14 250	10 950	8000	8000	5700	5000	5000	3600	3500	3500	2500	2550	2550	1750	2100	2100	1400				
	Narrow – 2 sets stabilizers down	*14 250	*14 250	*14 250	*11 500	*11 500	11 100	*8850	*8850	6800	6750	6750	4700	5000	5000	3500	4200	4200	2900				
3000 mm	SA – 2 sets stabilizers up							8200	8200	5850	5250	5250	3800	3700	3700	2700	2800	2800	2000	2200	2200	1550	10 280
	SA – 2 sets stabilizers down							*12 450	*12 450	*12 450	*9200	*9200	8750	*7200	*7200	6100	5700	5700	4550	*4500	*4500	3700	
	Narrow – 2 sets stabilizers up							7350	7350	5100	4700	4700	3350	3350	2350	2450	2450	1700	1950	1950	1300		
	Narrow – 2 sets stabilizers down							*12 400	*12 400	10 350	*9150	*9150	6450	6600	6600	4550	4900	4900	3400	3950	3950	2750	
1500 mm	SA – 2 sets stabilizers up							7550	7550	5300	4950	4950	3550	3550	2550	2700	2700	1900	2150	2150	1500	10 340	
	SA – 2 sets stabilizers down							*12 450	*12 450	*12 450	*9100	*9100	8400	*7000	*7000	5900	*5450	*5450	4450	*3950	*3950		3600
	Narrow – 2 sets stabilizers up							6700	6700	4550	4400	4400	3050	3150	2200	2400	2400	1600	1900	1900	1250		
	Narrow – 2 sets stabilizers down							*12 500	*12 500	9650	*9100	*9100	6150	6400	6400	4400	4800	4800	3300	3900	3900		2650
0 mm	SA – 2 sets stabilizers up							7200	7200	4950	4750	4750	3350	3450	3450	2400	2650	2650	1850				
	SA – 2 sets stabilizers down							*9400	*9400	*9400	*8350	*8350	8150	*6400	*6400	5800	*4800	*4800	4400				
	Narrow – 2 sets stabilizers up							6350	6350	4250	4200	4200	2850	3050	3050	2050	2350	2350	1550				
	Narrow – 2 sets stabilizers down							*9450	*9450	9250	*8400	*8400	5900	6250	6250	4250	4750	4750	3250				

\*Limited by hydraulic rather than tipping load.

Lift capacity ratings are based on ISO 10567:2007, they do not exceed 87% of hydraulic lifting capacity or 75% of tipping load. The load point is the center line of the bucket pivot mounting pin on the stick. The oscillating axle must be locked. Lifting capacities are based on the machine standing on a firm uniform supporting surface. For lifting capacity including bucket and/or quick coupler, the respective weight has to be subtracted from above values. The use of a work tool attachment point to handle/lift objects, could affect the machine lift performance.

Always refer to the appropriate Operation and Maintenance Manual for specific product information.



**Lift Capacities**

All values are in lb, bucket cylinder and linkage installed, without bucket, with counterweight (9260 lb), heavy lift on.



Undercarriage MH (9'0") or MH Narrow (8'4")		Boom 21'0" MH									Stick 13'9" Straight Stick									ft
		10 ft			15 ft			20 ft			25 ft			30 ft						
Stick	Undercarriage configuration	Load over front	Load over side	Load over rear	Load over front	Load over side	Load over rear	Load over front	Load over side	Load over rear	Load over front	Load over side	Load over rear	Load over front	Load over side	Load over rear	Load at maximum reach (sticknose/bucket pin)	ft		
30 ft	SA – 2 sets stabilizers up							12,500	12,500	9300							9100	9100	6700	23.85
	SA – 2 sets stabilizers down							*17,100	*17,100	*17,100							*11,800	*11,800	*11,800	
	Narrow – 2 sets stabilizers up							11,300	11,300	8300							8300	8300	6000	
	Narrow – 2 sets stabilizers down							*17,100	*17,100	15,100							*11,800	*11,800	11,100	
25 ft	SA – 2 sets stabilizers up							12,600	12,600	9400							6900	6900	5000	28.08
	SA – 2 sets stabilizers down							*18,000	*18,000	*18,000							*10,900	*10,900	*10,900	
	Narrow – 2 sets stabilizers up							11,400	11,400	8300							6200	6200	4400	
	Narrow – 2 sets stabilizers down							*18,000	*18,000	15,200							*10,900	*10,900	8400	
20 ft	SA – 2 sets stabilizers up							19,900	19,900	14,700							5800	5800	4100	30.91
	SA – 2 sets stabilizers down							*23,000	*23,000	*23,000							*10,500	*10,500	9500	
	Narrow – 2 sets stabilizers up							18,000	18,000	13,000							3800	5200	3600	
	Narrow – 2 sets stabilizers down							*23,000	*23,000	*23,000							10,200	10,200	7100	
15 ft	SA – 2 sets stabilizers up							18,900	18,900	13,700							5200	5200	3600	32.74
	SA – 2 sets stabilizers down							*31,000	*31,000	*31,000							*10,500	*10,500	8500	
	Narrow – 2 sets stabilizers up							*30,600	*30,600	23,400							3700	4600	3100	
	Narrow – 2 sets stabilizers down							*30,600	*30,600	*30,600							9100	9100	6300	
10 ft	SA – 2 sets stabilizers up							17,400	17,400	12,400							4200	4800	3400	33.73
	SA – 2 sets stabilizers down							*26,900	*26,900	*26,900							*9900	*9900	8000	
	Narrow – 2 sets stabilizers up							15,600	15,600	10,900							3600	4300	2800	
	Narrow – 2 sets stabilizers down							*26,900	*26,900	22,000							7200	8600	5900	
5 ft	SA – 2 sets stabilizers up							16,100	16,100	11,200							4000	4700	3200	33.92
	SA – 2 sets stabilizers down							*27,100	*27,100	*27,100							*8700	*8700	7900	
	Narrow – 2 sets stabilizers up							14,300	14,300	9700							3400	4100	2700	
	Narrow – 2 sets stabilizers down							*27,100	*27,100	20,500							7000	8400	5800	
0 ft	SA – 2 sets stabilizers up							15,300	15,300	10,500							3900			
	SA – 2 sets stabilizers down							*22,100	*22,100	*22,100							*10,200	*10,200	9400	
	Narrow – 2 sets stabilizers up							13,500	13,500	9000							4400	4900	3300	
	Narrow – 2 sets stabilizers down							*22,200	*22,200	19,600							9000	10,100	6900	

\*Limited by hydraulic rather than tipping load.

Lift capacity ratings are based on ISO 10567:2007, they do not exceed 87% of hydraulic lifting capacity or 75% of tipping load. The load point is the center line of the bucket pivot mounting pin on the stick. The oscillating axle must be locked. Lifting capacities are based on the machine standing on a firm uniform supporting surface. For lifting capacity including bucket and/or quick coupler, the respective weight has to be subtracted from above values. The use of a work tool attachment point to handle/lift objects, could affect the machine lift performance.

Always refer to the appropriate Operation and Maintenance Manual for specific product information.

**Lift Capacities**

All values are in kg, bucket cylinder and linkage installed, without bucket, with counterweight (4200 kg), heavy lift on.



Undercarriage Standard		Boom 6.4 m MH									Stick 4.2 m Straight Stick					
		3000 mm			4500 mm			6000 mm			7500 mm			9000 mm		
Load point height	Undercarriage configuration	Load over front	Load over front	Load over side	Load over front	Load over front	Load over side	Load over rear	Load over side	Load over side	Load over side	Load over side	Load over side	Load over side	Load at maximum reach (sticknose/bucket pin)	mm
9000 mm	Front stabilizer and rear dozer up														3950	2850
	Front stabilizer and rear dozer down														*5300	*5300
	2 sets stabilizers up														4050	2900
	2 sets stabilizers down														*5300	*5300
	Front dozer and rear stabilizer up														4100	2850
	Front dozer and rear stabilizer down														*5300	*5300
7500 mm	Front stabilizer and rear dozer up														3000	2150
	Front stabilizer and rear dozer down														*4900	*4900
	2 sets stabilizers up														3100	2200
	2 sets stabilizers down														*4900	*4900
	Front dozer and rear stabilizer up														3150	2150
	Front dozer and rear stabilizer down														*4900	*4900
6000 mm	Front stabilizer and rear dozer up														2550	1800
	Front stabilizer and rear dozer down														*4750	*4750
	2 sets stabilizers up														2000	3000
	2 sets stabilizers down														2000	2650
	Front dozer and rear stabilizer up														2800	3600
	Front dozer and rear stabilizer down														2800	2650
4500 mm	Front stabilizer and rear dozer up														2000	1800
	Front stabilizer and rear dozer down														*4750	*4750
	2 sets stabilizers up														2000	3000
	2 sets stabilizers down														2000	1800
	Front dozer and rear stabilizer up														2800	3600
	Front dozer and rear stabilizer down														2800	2650
3000 mm	Front stabilizer and rear dozer up														1850	1450
	Front stabilizer and rear dozer down														3150	4300
	2 sets stabilizers up														1900	2200
	2 sets stabilizers down														3800	4450
	Front dozer and rear stabilizer up														1850	2250
	Front dozer and rear stabilizer down														*4500	*3700
1500 mm	Front stabilizer and rear dozer up														1800	1400
	Front stabilizer and rear dozer down														*3950	*3950
	2 sets stabilizers up														1800	2150
	2 sets stabilizers down														3700	*3950
	Front dozer and rear stabilizer up														1800	2150
	Front dozer and rear stabilizer down														*3950	*3950
0 mm	Front stabilizer and rear dozer up														1700	3000
	Front stabilizer and rear dozer down														3000	1750
	2 sets stabilizers up														2300	2650
	2 sets stabilizers down														4750	*4800
	Front dozer and rear stabilizer up														2250	2650
	Front dozer and rear stabilizer down														4000	*4800

9

\* Limited by hydraulic rather than tipping load.

Lift capacity ratings are based on ISO 10567:2007, they do not exceed 87% of hydraulic lifting capacity or 75% of tipping load. The load point is the center line of the bucket pivot mounting pin on the stick. The oscillating axle must be locked. Lifting capacities are based on the machine standing on a firm uniform supporting surface. For lifting capacity including bucket and/or quick coupler, the respective weight has to be subtracted from above values. The use of a work tool attachment point to handle/lift objects, could affect the machine lift performance.

Always refer to the appropriate Operation and Maintenance Manual for specific product information.

**Lift Capacities**

All values are in lb, bucket cylinder and linkage installed, without bucket, with counterweight (9260 lb), heavy lift on.



**Undercarriage**

**Boom**

**Stick**

Standard

21'0" MH

13'9" Straight Stick

Stick	Undercarriage configuration	10 ft			15 ft			20 ft			25 ft			30 ft			ft			
		Load over front	Load over rear	Load over side	Load over front	Load over rear	Load over side	Load over front	Load over rear	Load over side	Load over front	Load over rear	Load over side	Load over front	Load over rear	Load over side	Load over front	Load over rear	Load over side	
30 ft	Front stabilizer and rear dozer up							12,200	11,600	8900										
	Front stabilizer and rear dozer down							*17,100	*17,100	13,700										
	2 sets stabilizers up							12,600	11,500	9000										
	2 sets stabilizers down							*17,100	*17,100	16,800										
	Front dozer and rear stabilizers up							12,700	11,200	8900										
	Front dozer and rear stabilizers down							*17,100	*17,100	14,100										
25 ft	Front stabilizer and rear dozer up							12,300	11,700	9000	8300	7900	6000							
	Front stabilizer and rear dozer down							*18,000	*18,000	13,800	*15,200	*15,200	9400							
	2 sets stabilizers up							12,600	11,600	9100	8600	7900	6100							
	2 sets stabilizers down							*18,000	*18,000	16,900	*15,200	14,300	11,500							
	Front dozer and rear stabilizers up							12,700	11,300	9000	8600	7600	6000							
	Front dozer and rear stabilizers down							*18,000	*18,000	14,200	*15,200	13,800	9600							
20 ft	Front stabilizer and rear dozer up				19,700	18,400	14,000	11,400	8700	8200	7900	5900	5600	4100						
	Front stabilizer and rear dozer down				*23,000	*23,000	22,100	*18,400	*18,400	13,500	*15,300	*15,300	9300	11,700	11,500	6700	*10,500	*10,500	6400	
	2 sets stabilizers up				20,200	18,300	14,200	12,400	11,400	8800	8500	7800	6000	6100	5600	4200	5800	5300	3900	
	2 sets stabilizers down				*23,000	*23,000	23,000	*18,400	*18,400	16,600	*15,300	14,200	11,400	11,900	10,300	8300	*10,500	9800	7900	
	Front dozer and rear stabilizers up				20,300	17,800	14,000	12,500	11,000	8700	8600	7500	5900	6200	5400	4100	5800	5100	3900	
	Front dozer and rear stabilizers down				*23,000	*23,000	22,800	*18,400	*18,400	13,900	*15,300	13,700	9500	*12,800	10,000	6900	*10,500	9500	6500	
15 ft	Front stabilizer and rear dozer up	*31,000	*31,000	25,600	18,600	17,400	13,100	11,600	10,900	8300	8000	7600	5700	5800	5600	4100	5000	4700	3400	
	Front stabilizer and rear dozer down	*31,000	*31,000	*31,000	*24,900	*24,900	21,000	*19,200	*19,200	13,000	*15,500	15,500	9000	11,600	11,400	6600	9900	9800	5700	
	2 sets stabilizers up	*31,000	*31,000	25,800	19,100	17,300	13,300	11,900	10,900	8400	8200	7600	5800	6000	5500	4100	5100	4700	3500	
	2 sets stabilizers down	*31,000	*31,000	*31,000	*24,900	*24,900	*24,900	*19,200	*19,200	16,100	*15,500	13,900	11,100	11,900	10,300	8200	10,200	8800	7000	
	Front dozer and rear stabilizers up	*31,000	*31,000	25,600	19,300	16,800	13,100	12,000	10,500	8300	8300	7300	5700	6100	5300	4100	5200	4500	3400	
	Front dozer and rear stabilizers down	*31,000	*31,000	*24,900	*24,900	*24,900	21,700	*19,200	*19,200	13,400	*15,500	13,500	9300	*12,700	9900	6800	*10,500	8500	5800	
10 ft	Front stabilizer and rear dozer up				17,200	16,000	11,800	10,900	10,300	7700	7700	7300	5400	5700	5400	3900	4600	4400	3100	
	Front stabilizer and rear dozer down				*26,900	*26,900	19,500	*19,900	*19,900	12,300	15,400	15,100	8700	11,400	11,200	6500	9400	9300	5300	
	2 sets stabilizers up				17,700	15,900	12,000	11,200	10,200	7800	7900	7200	5400	5900	5400	4000	4800	4400	3200	
	2 sets stabilizers down				*26,900	*26,900	24,900	*19,900	19,500	15,400	*15,600	13,500	10,800	11,700	10,100	8000	9700	8300	6600	
	Front dozer and rear stabilizers up				17,800	15,400	11,800	11,300	9900	7700	8000	7000	5400	5900	5200	3900	4800	4200	3100	
	Front dozer and rear stabilizers down				*26,900	*26,900	20,200	*19,900	18,900	12,700	*15,600	13,100	8900	*12,400	9800	6700	*9900	8100	5500	
5 ft	Front stabilizer and rear dozer up				15,800	14,700	10,600	10,200	9700	7100	7300	6900	5100	5500	5200	3700	4500	4300	3000	
	Front stabilizer and rear dozer down				*27,100	*27,100	18,100	*19,800	*19,800	11,700	15,000	14,700	8300	11,200	11,000	6300	*8700	*8700	5200	
	2 sets stabilizers up				16,300	14,600	10,800	10,600	9600	7200	7600	6900	5100	5700	5200	3800	4700	4300	3100	
	2 sets stabilizers down				*27,100	*27,100	23,300	*19,800	18,800	14,700	*15,200	13,100	10,400	11,500	9900	7900	*8700	8200	6500	
	Front dozer and rear stabilizers up				16,400	14,100	10,600	10,700	9300	7100	7600	6600	5100	5700	5000	3700	4700	4100	3000	
	Front dozer and rear stabilizers down				*27,100	*27,100	18,800	*19,800	18,200	12,000	*15,200	12,700	8600	*11,700	9600	6500	*8700	7900	5300	
0 ft	Front stabilizer and rear dozer up				15,000	13,900	9900	9800	9200	6600	7000	6700	4900	5400	5100	3600				
	Front stabilizer and rear dozer down				*22,100	*22,100	17,300	*18,100	*18,100	11,200	*13,800	*13,800	8100	*10,200	*10,200	6200				
	2 sets stabilizers up				15,500	13,800	10,000	10,100	9200	6700	7300	6600	4900	5600	5100	3700				
	2 sets stabilizers down				*22,100	*22,100	*22,100	*18,100	*18,100	14,100	*13,800	12,800	10,100	*10,200	9700	7700				
	Front dozer and rear stabilizers up				15,600	13,300	9900	10,200	8800	6600	7400	6400	4800	*5600	4900	3600				
	Front dozer and rear stabilizers down				*22,100	*22,100	17,900	*18,100	17,600	11,500	*13,800	12,400	8300	*10,200	9400	6300				

\*Limited by hydraulic rather than tipping load.

Lift capacity ratings are based on ISO 10567:2007, they do not exceed 87% of hydraulic lifting capacity or 75% of tipping load. The load point is the center line of the bucket pivot mounting pin on the stick. The oscillating axle must be locked. Lifting capacities are based on the machine standing on a firm uniform supporting surface. For lifting capacity including bucket and/or quick coupler, the respective weight has to be subtracted from above values. The use of a work tool attachment point to handle/lift objects, could affect the machine lift performance.

Always refer to the appropriate Operation and Maintenance Manual for specific product information.

**Lift Capacities**

All values are in kg, without bucket, with counterweight (4200 kg), heavy lift on.



**Undercarriage**

MH (2.75 m) or MH Narrow (2.55 m)

**Boom**

5.35 m MH

**Stick**

4.9 m MH

Stick height	Undercarriage configuration	3000 mm			4500 mm			6000 mm			7500 mm			9000 mm			Load at maximum reach (sticknose/bucket pin)			mm		
		Load over front	Load over rear	Load over side	Load over front	Load over rear	Load over side	Load over front	Load over rear	Load over side	Load over front	Load over rear	Load over side	Load over front	Load over rear	Load over side	Load over front	Load over rear	Load over side			
10500 mm	SA – 2 sets stabilizers up				*6800	*6800	*6800											*6150	*6150	*6150	4830	
	SA – 2 sets stabilizers down				*6800	*6800	*6800											*6150	*6150	*6150		
	Narrow – 2 sets stabilizers up				*6750	*6750	6400											*6200	*6200	5850		
	Narrow – 2 sets stabilizers down				*6750	*6750	*6750											*6200	*6200	*6200		
9000 mm	SA – 2 sets stabilizers up							6250	6250	4800								5000	5000	3800	6910	
	SA – 2 sets stabilizers down							*6800	*6800	*6800								*5000	*5000	*5000		
	Narrow – 2 sets stabilizers up							5700	5700	4300								4550	4550	3400		
	Narrow – 2 sets stabilizers down							*6750	*6750	*6750								*5000	*5000	*5000		
7500 mm	SA – 2 sets stabilizers up							6350	6350	4850	4450	4450	3400					3850	3850	2900	8210	
	SA – 2 sets stabilizers down							*8000	*8000	*8000	*6200	*6200	*6200					*4550	*4550	*4550		
	Narrow – 2 sets stabilizers up							5800	5800	4350	4050	4050	3050					3500	3500	2600		
	Narrow – 2 sets stabilizers down							*8000	*8000	7600	*6200	*6200	5300					*4550	*4550	*4550		
6000 mm	SA – 2 sets stabilizers up							6300	6300	4850	4450	4450	3400	3300	3300	2500		3250	3250	2500	9080	
	SA – 2 sets stabilizers down							*8400	*8400	*8400	*7400	*7400	6850	*4600	*4600	*4600		*4350	*4350	*4350		
	Narrow – 2 sets stabilizers up							5750	5750	4350	4050	4050	3050	3000	3000	2250		2950	2950	2200		
	Narrow – 2 sets stabilizers down							*8400	*8400	7550	7350	7350	5300	*4550	*4550	3950		*4350	*4350	3900		
4500 mm	SA – 2 sets stabilizers up							6150	6150	4700	4400	4400	3350	3300	3300	2500		2950	2950	2250	9630	
	SA – 2 sets stabilizers down							*8800	*8800	*8800	*7500	*7500	6800	6250	6250	5100		*4300	*4300	*4300		
	Narrow – 2 sets stabilizers up							5600	5600	4200	4000	4000	3000	3000	3000	2200		2700	2700	1950		
	Narrow – 2 sets stabilizers down							*8800	*8800	7400	7250	7250	5200	5450	5450	3950		*4300	*4300	3550		
3000 mm	SA – 2 sets stabilizers up							9250	9250	6850	5950	5950	4500	4250	4250	3250	3250	2450	2800	2800	2100	9930
	SA – 2 sets stabilizers down							*11 850	*11 850	*11 850	*9350	*9350	*9350	*7700	*7700	6650	6150	5050	*4350	*4350	4350	
	Narrow – 2 sets stabilizers up							8400	8400	6100	5400	5400	4000	3850	3850	2850	2950	2150	2550	2550	1850	
	Narrow – 2 sets stabilizers down							*11 800	*11 800	11 500	*9350	*9350	7200	7150	7150	5100	5350	3850	*4350	*4350	3350	
1500 mm	SA – 2 sets stabilizers up	17 100	17 100	11 550	8700	8700	6350	5700	5700	4250	4150	4150	3100	3200	3200	2400		2750	2750	2050	9990	
	SA – 2 sets stabilizers down	*19 950	*19 950	*19 950	*13 050	*13 050	*13 050	*9750	*9750	9200	*7700	*7700	6500	6100	6100	4950		*4550	*4550	4250		
	Narrow – 2 sets stabilizers up	15 150	15 150	10 100	7850	7850	5600	5150	5150	3750	3750	3750	2750	2850	2850	2100		2450	2450	1800		
	Narrow – 2 sets stabilizers down	*19 900	*19 900	*19 900	*13 050	*13 050	10 500	*9750	*9750	6900	7000	7000	4950	5300	5300	3800		4550	4550	3250		
0 mm	SA – 2 sets stabilizers up	*8150	*8150	*8150	8250	8250	5900	5450	5450	4000	4000	4000	3000	3100	3100	2350						
	SA – 2 sets stabilizers down	*8150	*8150	*8150	*13 150	*13 150	*13 150	*9600	*9600	8900	*7350	*7350	6350	*5500	*5500	4900						
	Narrow – 2 sets stabilizers up	*8250	*8250	*8250	7350	7350	5200	4900	4900	3550	3600	3600	2650	2800	2800	2050						
	Narrow – 2 sets stabilizers down	*8250	*8250	*8250	*13 150	*13 150	10 350	*9650	*9650	6650	6850	6850	4800	5250	5250	3750						
-1500 mm	SA – 2 sets stabilizers up	*7250	*7250	*7250	7950	7950	5700	5300	5300	3900	3950	3950	2900									
	SA – 2 sets stabilizers down	*7250	*7250	*7250	*11 600	*11 600	*11 600	*8550	*8550	*8550	*6350	*6350	6250									
	Narrow – 2 sets stabilizers up	*7250	*7250	*7250	7100	7100	4950	4750	4750	3400	3550	3550	2550									
	Narrow – 2 sets stabilizers down	*7250	*7250	*7250	*11 650	*11 650	10 050	*8600	*8600	6500	*6350	*6350	4750									

\* Limited by hydraulic rather than tipping load.

Lift capacity ratings are based on ISO 10567:2007, they do not exceed 87% of hydraulic lifting capacity or 75% of tipping load. The load point is the center line of the bucket pivot mounting pin on the stick. The oscillating axle must be locked. Lifting capacities are based on the machine standing on a firm uniform supporting surface. For lifting capacity including bucket and/or quick coupler, the respective weight has to be subtracted from above values. The use of a work tool attachment point to handle/lift objects, could affect the machine lift performance.

Always refer to the appropriate Operation and Maintenance Manual for specific product information.

### Lift Capacities

All values are in lb, without bucket, with counterweight (9260 lb), heavy lift on.



#### Undercarriage

MH (9'0") or MH Narrow (8'4")

#### Boom

17'7" MH

#### Stick

16'1" MH

Stick height	Undercarriage configuration	10 ft			15 ft			20 ft			25 ft			30 ft			Load at maximum reach (sticknose/bucket pin)			ft					
		Load over front	Load over rear	Load over side	Load over front	Load over rear	Load over side	Load over front	Load over rear	Load over side	Load over front	Load over rear	Load over side	Load over front	Load over rear	Load over side	Load over front	Load over rear	Load over side						
35 ft	SA – 2 sets stabilizers up																								
	SA – 2 sets stabilizers down																								
	Narrow – 2 sets stabilizers up																								
	Narrow – 2 sets stabilizers down																								
30 ft	SA – 2 sets stabilizers up							13,200	13,200	10,100															
	SA – 2 sets stabilizers down							*14,100	*14,100	*14,100															
	Narrow – 2 sets stabilizers up							12,000	12,000	9,000															
	Narrow – 2 sets stabilizers down							*14,000	*14,000	*14,000															
25 ft	SA – 2 sets stabilizers up							13,500	13,500	10,300	9,400	9,400	7,200												
	SA – 2 sets stabilizers down							*17,300	*17,300	*17,300	*12,800	*12,800	*12,800												
	Narrow – 2 sets stabilizers up							12,300	12,300	9,200	8,500	8,500	6,400												
	Narrow – 2 sets stabilizers down							*17,200	*17,200	16,100	*12,700	*12,700	11,200												
20 ft	SA – 2 sets stabilizers up							13,400	13,400	10,200	9,400	9,400	7,200												
	SA – 2 sets stabilizers down							*18,300	*18,300	*18,300	*16,100	*16,100	14,500												
	Narrow – 2 sets stabilizers up							12,200	12,200	9,200	8,600	8,600	6,400												
	Narrow – 2 sets stabilizers down							*18,300	*18,300	16,000	15,600	15,600	11,200												
15 ft	SA – 2 sets stabilizers up							13,100	13,100	10,000	9,300	9,300	7,100	7,000	7,000	5,300	6,400	6,400	4,800						
	SA – 2 sets stabilizers down							*19,100	*19,100	*19,100	*16,300	*16,300	14,400	*12,800	*12,800	10,800	*9,400	*9,400	*9,400						
	Narrow – 2 sets stabilizers up							11,900	11,900	8,900	8,400	8,400	6,300	6,300	6,300	4,600	5,800	5,800	4,300						
	Narrow – 2 sets stabilizers down							*19,100	*19,100	15,700	15,400	15,400	11,100	11,500	11,500	8,300	*9,400	*9,400	7,700						
10 ft	SA – 2 sets stabilizers up							19,700	19,700	14,600	12,600	12,600	9,500	9,000	9,000	6,800	6,900	6,900	5,200	6,100	6,100	4,500			
	SA – 2 sets stabilizers down							*25,600	*25,600	*25,600	*20,300	*20,300	20,100	*16,600	*16,600	14,100	13,100	13,100	10,700	*9,600	*9,600	9,400			
	Narrow – 2 sets stabilizers up							17,800	17,800	13,000	11,500	11,500	8,500	8,200	8,200	6,000	6,200	6,200	4,500	5,500	5,500	4,000			
	Narrow – 2 sets stabilizers down							*25,600	*25,600	24,400	*20,200	*20,200	15,200	15,100	15,100	10,800	11,400	11,400	8,200	*9,600	*9,600	7,200			
5 ft	SA – 2 sets stabilizers up							36,200	36,200	24,600	18,500	18,500	13,500	12,100	12,100	9,000	8,800	8,800	6,500	6,700	6,700	5,000	5,900	5,900	4,400
	SA – 2 sets stabilizers down							*43,100	*43,100	*43,100	*28,200	*28,200	*28,200	*21,100	*21,100	19,500	*16,700	*16,700	13,800	12,900	12,900	10,500	*10,000	*10,000	9,200
	Narrow – 2 sets stabilizers up							32,100	32,100	21,400	16,600	16,600	11,900	10,900	10,900	8,000	7,900	7,900	5,800	6,100	6,100	4,400	5,300	5,300	3,800
	Narrow – 2 sets stabilizers down							*43,000	*43,000	*43,000	*28,200	*28,200	23,000	*21,100	*21,100	14,600	14,800	14,800	10,500	11,200	11,200	8,000	9,900	9,900	7,100
0 ft	SA – 2 sets stabilizers up							*18,800	*18,800	*18,800	17,500	17,500	12,500	11,800	11,800	8,500	8,500	6,300	6,600	6,600	4,900				
	SA – 2 sets stabilizers down							*18,800	*18,800	*18,800	*28,500	*28,500	*28,500	*20,800	*20,800	18,900	*15,900	*15,900	13,500	*11,600	*11,600	10,400			
	Narrow – 2 sets stabilizers up							*19,000	*19,000	*19,000	15,600	15,600	11,000	10,400	10,400	7,500	7,600	7,600	5,500	5,900	5,900	4,300			
	Narrow – 2 sets stabilizers down							*19,000	*19,000	*19,000	*28,500	*28,500	21,900	20,600	20,600	14,100	14,500	14,500	10,200	11,100	11,100	7,900			
-5 ft	SA – 2 sets stabilizers up							*16,400	*16,400	*16,400	16,900	16,900	12,000	11,200	11,200	8,200	8,300	8,300	6,100						
	SA – 2 sets stabilizers down							*16,400	*16,400	*16,400	*25,000	*25,000	*25,000	*18,400	*18,400	*18,400	*13,500	*13,500	13,300						
	Narrow – 2 sets stabilizers up							*16,400	*16,400	*16,400	15,100	15,100	10,500	10,100	10,100	7,200	7,500	7,500	5,400						
	Narrow – 2 sets stabilizers down							*16,400	*16,400	*16,400	*25,100	*25,100	21,300	*18,500	*18,500	13,800	*13,600	*13,600	10,000						

\*Limited by hydraulic rather than tipping load.

Lift capacity ratings are based on ISO 10567:2007, they do not exceed 87% of hydraulic lifting capacity or 75% of tipping load. The load point is the center line of the bucket pivot mounting pin on the stick. The oscillating axle must be locked. Lifting capacities are based on the machine standing on a firm uniform supporting surface. For lifting capacity including bucket and/or quick coupler, the respective weight has to be subtracted from above values. The use of a work tool attachment point to handle/lift objects, could affect the machine lift performance.

Always refer to the appropriate Operation and Maintenance Manual for specific product information.

**Lift Capacities**

All values are in kg, without bucket, with counterweight (4200 kg), heavy lift on.



**Undercarriage**

**Boom**  
5.35 m MH

**Stick**  
4.9 m MH

Load point height	Undercarriage configuration	3000 mm			4500 mm			6000 mm			7500 mm			9000 mm			mm	
		Load over front	Load over rear	Load over side	Load over front	Load over rear	Load over side	Load over front	Load over rear	Load over side	Load over front	Load over rear	Load over side	Load over front	Load over rear	Load over side	mm	
10 500 mm	Front stabilizer and rear dozer up				*6800		*6800									*6150	*6150	4830
	Front stabilizer and rear dozer down				*6800	*6800	*6800									*6150	*6150	
	2 sets stabilizers up				*6800		*6800									*6150	*6150	
	2 sets stabilizers down				*6800		*6800									*6150	*6150	
	Front dozer and rear stabilizer up				*6800		*6800									*6150	*6150	
	Front dozer and rear stabilizer down				*6800	*6800	*6800									*6150	*6150	
9000 mm	Front stabilizer and rear dozer up							6150		4600						4850	3650	6910
	Front stabilizer and rear dozer down							*6800	*6800	*6800						*5000	*5000	
	2 sets stabilizers up							6300		4650						*5000	3650	
	2 sets stabilizers down							*6800		*6800						*5000	*5000	
	Front dozer and rear stabilizer up							6350		4600						*5000	3650	
	Front dozer and rear stabilizer down							*6800	*6800	*6800						*5000	*5000	
7500 mm	Front stabilizer and rear dozer up							6250		4650	4350					3750	2800	8210
	Front stabilizer and rear dozer down							*8000	*8000	7100	*6200	4950				*4550	*4550	
	2 sets stabilizers up							6400		4700	4450	3300				3850	2800	
	2 sets stabilizers down							*8000		*8000	*6200	5800				*4550	*4550	
	Front dozer and rear stabilizer up							6450		4650	4500	3250				3850	2800	
	Front dozer and rear stabilizer down							*8000	*8000	7250	*6200	*6200	5050			*4550	*4550	
6000 mm	Front stabilizer and rear dozer up							6200		4650	4350					3200	3150	9080
	Front stabilizer and rear dozer down							*8400	*8400	7050	*7400	4950	*4600			2400	*4350	
	2 sets stabilizers up							6350		4700	4450	3300	3300			2400	3250	
	2 sets stabilizers down							*8400		8350	*7400	5800	*4600			4350	*4350	
	Front dozer and rear stabilizer up							6400		4650	4500	3250	3350			2400	3300	
	Front dozer and rear stabilizer down							*8400	*8400	7200	*7400	6900	5050	*4600		3750	*4350	
4500 mm	Front stabilizer and rear dozer up							6050		4500	4250					3200	2850	9630
	Front stabilizer and rear dozer down							*8800	*8800	6900	*7500	*7500	4900	5900	5800	3650	*4300	
	2 sets stabilizers up							6200		4550	4400					2400	2950	
	2 sets stabilizers down							*8800		8200	*7500	5750	6050			4300	*4300	
	Front dozer and rear stabilizer up							6250		4500	4400					2400	2950	
	Front dozer and rear stabilizer down							*8800	*8800	7050	*7500	6850	5000	*6300	5100	3750	*4300	
3000 mm	Front stabilizer and rear dozer up							9150		6600	5800					3100	2700	9930
	Front stabilizer and rear dozer down							*11 850	*11 850	10 600	*9350	*9350	6700	*7700	7650	4750	5800	
	2 sets stabilizers up							9400		6650	6000					3100	3250	
	2 sets stabilizers down							*11 850		*9350	7950	*7700				5600	6000	
	Front dozer and rear stabilizer up							9450		6600	6000					3100	3250	
	Front dozer and rear stabilizer down							*11 850	*11 850	10 900	*9350	*9350	6850	*7700	6700	4850	*6350	
1500 mm	Front stabilizer and rear dozer up	17 300						8600		6050	5550					2950	3100	9990
	Front stabilizer and rear dozer down	*19 950	*19 950	*19 950	*13 050			10 000	*9750	*9750	6400	7650	7500	4600	5750	5650	3550	
	2 sets stabilizers up	17 750						8800		6150	5700					3000	3200	
	2 sets stabilizers down	*19 950						*19 950	*13 050	12 250	*9750	7650	*7700	5450	5900	4200	*4550	
	Front dozer and rear stabilizer up	17 850						8850		6050	5750					2950	3200	
	Front dozer and rear stabilizer down	*19 950	*19 950	*19 950	*13 050	*13 050			10 300	*9750	9350	6550	*7700	6550	4700	*6100	5000	
0 mm	Front stabilizer and rear dozer up	*8150						8100		5650	5300					2850	3000	
	Front stabilizer and rear dozer down	*8150	*8150	*8150	*13 150	*13 150		9500	*9600	*9600	6150	*7350	7350	4500	*5100	*5500	3500	
	2 sets stabilizers up	*8150						8350		5700	5500					2850	3100	
	2 sets stabilizers down	*8150						*8150	*13 150	11 700	*9600	7400	*7350	5350	*5500	4100	2250	
	Front dozer and rear stabilizer up	*8150						8400		5650	5500					2850	3150	
	Front dozer and rear stabilizer down	*8150	*8150	*8150	*13 150	*13 150		9750	*9600	9050	6300	*7350	6400	4600	*5500	4900	3550	
-1500 mm	Front stabilizer and rear dozer up	*7250						7800		5400	5150					2750	3800	
	Front stabilizer and rear dozer down	*7250	*7250	*7250	*11 600	*11 600		9200	*8550	*8550	6000	*6350	6350	4400			2800	
	2 sets stabilizers up	*7250						8050		5450	5300					2800	2800	
	2 sets stabilizers down	*7250						*7250	*11 600	11 350	*8550	7250	*6350	5250			2500	
	Front dozer and rear stabilizer up	*7250						8100		5400	5350					2750	3950	
	Front dozer and rear stabilizer down	*7250	*7250	*7250	*11 600	*11 600		9500	*8550	*8550	6150	*6350	6350	4500			2800	

\*Limited by hydraulic rather than tipping load.

Lift capacity ratings are based on ISO 10567:2007, they do not exceed 87% of hydraulic lifting capacity or 75% of tipping load. The load point is the center line of the bucket pivot mounting pin on the stick. The oscillating axle must be locked. Lifting capacities are based on the machine standing on a firm uniform supporting surface. For lifting capacity including bucket and/or quick coupler, the respective weight has to be subtracted from above values. The use of a work tool attachment point to handle/lift objects, could affect the machine lift performance.

Always refer to the appropriate Operation and Maintenance Manual for specific product information.

### Lift Capacities

All values are in lb, without bucket, with counterweight (9260 lb), heavy lift on.



Undercarriage Standard		Boom 17'7" MH									Stick 16'1" MH										
		10 ft			15 ft			20 ft			25 ft			30 ft			ft				
Load point height	Undercarriage configuration	Load over front	Load over rear	Load over side	Load over front	Load over rear	Load over side	Load over front	Load over rear	Load over side	Load over front	Load over rear	Load over side	Load over front	Load over rear	Load over side	Load over front	Load over rear	Load over side	ft	
35 ft	Front stabilizer and rear dozer up																				
	Front stabilizer and rear dozer down																				
	2 sets stabilizers up																				
	2 sets stabilizers down																				
	Front dozer and rear stabilizers up																				
30 ft	Front stabilizer and rear dozer up																				
	Front stabilizer and rear dozer down																				
	2 sets stabilizers up																				
	2 sets stabilizers down																				
	Front dozer and rear stabilizers up																				
25 ft	Front stabilizer and rear dozer up																				
	Front stabilizer and rear dozer down																				
	2 sets stabilizers up																				
	2 sets stabilizers down																				
	Front dozer and rear stabilizers up																				
20 ft	Front stabilizer and rear dozer up																				
	Front stabilizer and rear dozer down																				
	2 sets stabilizers up																				
	2 sets stabilizers down																				
	Front dozer and rear stabilizers up																				
15 ft	Front stabilizer and rear dozer up																				
	Front stabilizer and rear dozer down																				
	2 sets stabilizers up																				
	2 sets stabilizers down																				
	Front dozer and rear stabilizers up																				
10 ft	Front stabilizer and rear dozer up																				
	Front stabilizer and rear dozer down																				
	2 sets stabilizers up																				
	2 sets stabilizers down																				
	Front dozer and rear stabilizers up																				
5 ft	Front stabilizer and rear dozer up																				
	Front stabilizer and rear dozer down																				
	2 sets stabilizers up																				
	2 sets stabilizers down																				
	Front dozer and rear stabilizers up																				
0 ft	Front stabilizer and rear dozer up																				
	Front stabilizer and rear dozer down																				
	2 sets stabilizers up																				
	2 sets stabilizers down																				
	Front dozer and rear stabilizers up																				
-5 ft	Front stabilizer and rear dozer up																				
	Front stabilizer and rear dozer down																				
	2 sets stabilizers up																				
	2 sets stabilizers down																				
	Front dozer and rear stabilizers up																				

\*Limited by hydraulic rather than tipping load.

Lift capacity ratings are based on ISO 10567:2007, they do not exceed 87% of hydraulic lifting capacity or 75% of tipping load. The load point is the center line of the bucket pivot mounting pin on the stick. The oscillating axle must be locked. Lifting capacities are based on the machine standing on a firm uniform supporting surface. For lifting capacity including bucket and/or quick coupler, the respective weight has to be subtracted from above values. The use of a work tool attachment point to handle/lift objects, could affect the machine lift performance.

Always refer to the appropriate Operation and Maintenance Manual for specific product information.

**Lift Capacities**

All values are in kg, bucket cylinder and linkage installed, without bucket, with counterweight (4200 kg), heavy lift on.



**Undercarriage**

MH (2.75 m) or MH Narrow (2.55 m)

**Boom**

5.35 m MH

**Stick**

4.2 m Straight Stick

Stick height	Undercarriage configuration	3000 mm			4500 mm			6000 mm			7500 mm			9000 mm			Stick			mm
		Load point height	Load over front	Load over rear	Load over front	Load over rear	Load over side	Load point height	Load over front	Load over rear	Load over front	Load over rear	Load over side	Load point height	Load over front	Load over rear	Load over front	Load over rear	Load over side	
9000 mm	SA – 2 sets stabilizers up				*8500	*8500	6950										*5750	*5750	4400	5900
	SA – 2 sets stabilizers down				*8500	*8500	*8500										*5750	*5750	*5750	
	Narrow – 2 sets stabilizers up				*8500	*8500	6200										5400	5400	3950	
	Narrow – 2 sets stabilizers down				*8500	*8500	*8500										*5800	*5800	*5800	
7500 mm	SA – 2 sets stabilizers up							5900	5900	4450							4150	4150	3050	7380
	SA – 2 sets stabilizers down							*8250	*8250	*8250							*5100	*5100	*5100	
	Narrow – 2 sets stabilizers up							5350	5350	3950							3750	3750	2700	
	Narrow – 2 sets stabilizers down							*8200	*8200	7150							*5100	*5100	5000	
6000 mm	SA – 2 sets stabilizers up							5900	5900	4400	4050	4050	3000				3350	3350	2450	8340
	SA – 2 sets stabilizers down							*8600	*8600	*8600	*7300	*7300	6450				*4800	*4800	*4800	
	Narrow – 2 sets stabilizers up							5350	5350	3900	3650	3650	2650				3050	3050	2150	
	Narrow – 2 sets stabilizers down							*8600	*8600	7100	6950	6950	4900				*4800	*4800	4050	
4500 mm	SA – 2 sets stabilizers up				9200	9200	6750	5750	5750	4250	4000	4000	2950				2950	2950	2150	8940
	SA – 2 sets stabilizers down				*11 100	*11 100	*11 100	*8900	*8900	*8900	*7350	*7350	6400				*4750	*4750	*4750	
	Narrow – 2 sets stabilizers up				8300	8300	6000	5200	5200	3800	3600	3600	2600				2650	2650	1850	
	Narrow – 2 sets stabilizers down				*11 050	*11 050	*11 050	*8900	*8900	7000	6850	6850	4850				*4750	*4750	3600	
3000 mm	SA – 2 sets stabilizers up	17 750	17 750	12 050	8700	8700	6300	5500	5500	4050	3900	3900	2850	2900	2900	2100	2750	2750	2000	9260
	SA – 2 sets stabilizers down	*18 000	*18 000	*18 000	*12 250	*12 250	*12 250	*9300	*9300	9050	*7400	*7400	6250	*5750	*5750	4650	*4850	*4850	4450	
	Narrow – 2 sets stabilizers up	15 750	15 750	10 550	7850	7850	5600	4950	4950	3600	3500	3500	2500	2600	2600	1800	2450	2450	1700	
	Narrow – 2 sets stabilizers down	*17 950	*17 950	*17 950	*12 200	*12 200	10 900	*9300	*9300	6750	6750	6750	4700	5000	5000	3500	4800	4800	3350	
1500 mm	SA – 2 sets stabilizers up	*11 900	*11 900	10 650	8150	8150	5850	5250	5250	3850	3750	3750	2750	2850	2850	2050	2700	2700	1950	9320
	SA – 2 sets stabilizers down	*11 900	*11 900	*11 900	*12 950	*12 950	*12 950	*9450	*9450	8750	*7250	*7250	6150	*5300	*5300	4600	*4750	*4750	4400	
	Narrow – 2 sets stabilizers up	*12 350	*12 350	9200	7300	7300	5100	4750	4750	3350	3350	3350	2400	2550	2550	1750	2400	2400	1650	
	Narrow – 2 sets stabilizers down	*12 350	*12 350	*12 350	*12 950	*12 950	10 300	*9450	*9450	6450	6600	6600	4600	4950	4950	3450	4700	4700	3300	
0 mm	SA – 2 sets stabilizers up	*6250	*6250	*6250	7750	7750	5450	5050	5050	3650	3650	3650	2650							
	SA – 2 sets stabilizers down	*6250	*6250	*6250	*12 250	*12 250	*12 250	*8900	*8900	8500	*6600	*6600	6000							
	Narrow – 2 sets stabilizers up	*6250	*6250	*6250	6900	6900	4750	4550	4550	3150	3250	3250	2300							
	Narrow – 2 sets stabilizers down	*6250	*6250	*6250	*12 300	*12 300	9850	*8900	*8900	6250	6500	6500	4500							
-1500 mm	SA – 2 sets stabilizers up				7600	7600	5300	4950	4950	3550										
	SA – 2 sets stabilizers down				*9850	*9850	*9850	*7300	*7300	*7300										
	Narrow – 2 sets stabilizers up				6700	6700	4550	4400	4400	3050										
	Narrow – 2 sets stabilizers down				*9950	*9950	9650	*7350	*7350	6150										

\*Limited by hydraulic rather than tipping load.

Lift capacity ratings are based on ISO 10567:2007, they do not exceed 87% of hydraulic lifting capacity or 75% of tipping load. The load point is the center line of the bucket pivot mounting pin on the stick. The oscillating axle must be locked. Lifting capacities are based on the machine standing on a firm uniform supporting surface. For lifting capacity including bucket and/or quick coupler, the respective weight has to be subtracted from above values. The use of a work tool attachment point to handle/lift objects, could affect the machine lift performance.

Always refer to the appropriate Operation and Maintenance Manual for specific product information.



# Material Handlers

## Lifting Capacities ● MH3022 (Grenoble Sourced)

### Lift Capacities

All values are in lb, bucket cylinder and linkage installed, without bucket, with counterweight (9260 lb), heavy lift on.

		Load point height			Load over front			Load over rear			Load over side			Load at maximum reach (sticknose/bucket pin)								
		<b>Undercarriage</b> MH (9'0") or MH Narrow (8'4")						<b>Boom</b> 17'7" MH						<b>Stick</b> 13'9" Straight Stick								
	Undercarriage configuration	10 ft			15 ft			20 ft			25 ft			30 ft						ft		
30 ft	SA – 2 sets stabilizers up				*18,200	*18,200	14,700												*12,900	*12,900	10,100	18.73
	SA – 2 sets stabilizers down				*18,200	*18,200	*18,200												*12,900	*12,900	*12,900	
	Narrow – 2 sets stabilizers up				18,000	18,000	13,100												12,400	12,400	9100	
	Narrow – 2 sets stabilizers down				*18,100	*18,100	*18,100												*13,000	*13,000	*13,000	
25 ft	SA – 2 sets stabilizers up							12,500	12,500	9400									9200	9200	6800	23.88
	SA – 2 sets stabilizers down							*17,600	*17,600	*17,600									*11,300	*11,300	*11,300	
	Narrow – 2 sets stabilizers up							11,300	11,300	8300									8300	8300	6000	
	Narrow – 2 sets stabilizers down							*17,500	*17,500	15,200									*11,300	*11,300	11,200	
20 ft	SA – 2 sets stabilizers up							12,500	12,500	9300	8600	8600	6400						7400	7400	5400	27.20
	SA – 2 sets stabilizers down							*18,700	*18,700	*18,700	*15,500	*15,500	13,700						*10,600	*10,600	*10,600	
	Narrow – 2 sets stabilizers up							11,300	11,300	8300	7700	7700	5600						6700	6700	4700	
	Narrow – 2 sets stabilizers down							*18,700	*18,700	15,100	14,700	14,700	10,400						*10,600	*10,600	9000	
15 ft	SA – 2 sets stabilizers up				19,600	19,600	14,400	12,200	12,200	9100	8500	8500	6300						6500	6500	4700	29.27
	SA – 2 sets stabilizers down				*24,000	*24,000	*24,000	*19,300	*19,300	*19,300	*16,000	*16,000	13,600						*10,500	*10,500	10,400	
	Narrow – 2 sets stabilizers up				17,700	17,700	12,800	11,000	11,000	8000	7600	7600	5500						5800	5800	4100	
	Narrow – 2 sets stabilizers down				*24,000	*24,000	*24,000	*19,300	*19,300	14,800	14,600	14,600	10,300						*10,500	*10,500	7900	
10 ft	SA – 2 sets stabilizers up	37,700	37,700	25,700	18,500	18,500	13,500	11,700	11,700	8600	8300	8300	6000	6100	6100	4400	6000	6000	4300	30.35		
	SA – 2 sets stabilizers down	*38,800	*38,800	*38,800	*26,500	*26,500	*26,500	*20,200	*20,200	19,200	*16,000	*16,000	13,300	*12,000	*12,000	9900	*10,700	*10,700	9700			
	Narrow – 2 sets stabilizers up	33,400	33,400	22,500	16,700	16,700	11,900	10,600	10,600	7600	7400	7400	5300	5500	5500	3800	5400	5400	3700			
	Narrow – 2 sets stabilizers down	*38,700	*38,700	*38,700	*26,400	*26,400	23,200	*20,200	*20,200	14,300	14,400	14,400	10,000	10,600	10,600	7400	10,500	10,500	7300			
5 ft	SA – 2 sets stabilizers up	*29,500	*29,500	22,700	17,400	17,400	12,400	11,200	11,200	8100	8000	8000	5800	6000	6000	4300	5900	5900	4200	30.58		
	SA – 2 sets stabilizers down	*29,500	*29,500	*29,500	*28,000	*28,000	*20,500	*20,500	18,600	*15,600	*15,600	13,000	*11,200	*11,200	9800	*10,500	*10,500	9500				
	Narrow – 2 sets stabilizers up	30,000	30,000	19,500	15,500	15,500	10,800	10,000	10,000	7100	7200	7200	5000	5400	5400	3700	5200	5200	3600			
	Narrow – 2 sets stabilizers down	*30,800	*30,800	*30,800	*28,000	*28,000	21,900	20,300	20,300	13,800	14,100	14,100	9700	10,500	10,500	7300	10,200	10,200	7100			
0 ft	SA – 2 sets stabilizers up	*14,400	*14,400	*14,400	16,500	16,500	11,600	10,800	10,800	7700	7800	7800	5600									
	SA – 2 sets stabilizers down	*14,400	*14,400	*14,400	*26,600	*26,600	*19,200	*19,200	18,100	*14,100	*14,100	12,800										
	Narrow – 2 sets stabilizers up	*14,400	*14,400	*14,400	14,700	14,700	10,100	9600	9600	6700	6900	6900	4800									
	Narrow – 2 sets stabilizers down	*14,400	*14,400	*14,400	*26,700	*26,700	20,900	*19,300	*19,300	13,300	13,800	13,800	9500									
-5 ft	SA – 2 sets stabilizers up				16,100	16,100	11,200	10,500	10,500	7500												
	SA – 2 sets stabilizers down				*21,300	*21,300	*21,300	*15,700	*15,700	*15,700												
	Narrow – 2 sets stabilizers up				14,300	14,300	9700	9400	9400	6500												
	Narrow – 2 sets stabilizers down				*21,500	*21,500	20,500	*15,800	*15,800	13,000												

\*Limited by hydraulic rather than tipping load.

Lift capacity ratings are based on ISO 10567:2007, they do not exceed 87% of hydraulic lifting capacity or 75% of tipping load. The load point is the center line of the bucket pivot mounting pin on the stick. The oscillating axle must be locked. Lifting capacities are based on the machine standing on a firm uniform supporting surface. For lifting capacity including bucket and/or quick coupler, the respective weight has to be subtracted from above values. The use of a work tool attachment point to handle/lift objects, could affect the machine lift performance.

Always refer to the appropriate Operation and Maintenance Manual for specific product information.

**Lift Capacities**

All values are in kg, bucket cylinder and linkage installed, without bucket, with counterweight (4200 kg), heavy lift on.

Load point height

Load over front

Load over rear

Load over side

Load at maximum reach (sticknose/bucket pin)

**Undercarriage**

**Boom**  
5.35 m MH

**Stick**  
4.2 m Straight Stick

Standard

	Undercarriage configuration	3000 mm			4500 mm			6000 mm			7500 mm			9000 mm					mm	
9000 mm	Front stabilizer and rear dozer up				*8550		6700										*5750		4200	
	Front stabilizer and rear dozer down				*8550	*8550	*8550											*5750	*5750	4200
	2 sets stabilizers up				*8550		6750											*5750		4250
	2 sets stabilizers down				*8550		*8550											*5750		*5750
	Front dozer and rear stabilizer up				*8550		6700											*5750		4200
Front dozer and rear stabilizer down				*8550	*8550	*8550												*5750	*5750	4200
7500 mm	Front stabilizer and rear dozer up						5800			4250								4000		2900
	Front stabilizer and rear dozer down						*8250	*8250	6650									*5100	*5100	4650
	2 sets stabilizers up						5950		4300									4150		2950
	2 sets stabilizers down						*8250	*8250	7950									*5100		*5100
	Front dozer and rear stabilizer up						6000		4250									4150		2900
Front dozer and rear stabilizer down						*8250	*8250	6800									*5100	*5100	4750	
6000 mm	Front stabilizer and rear dozer up						5750		4200	3950		2850						3250		2350
	Front stabilizer and rear dozer down						*8600	*8600	6600	*7300	*7300	4550						*4800	*4800	3800
	2 sets stabilizers up						5900		4250	4050		2900						3350		2350
	2 sets stabilizers down						*8600	*8600	7900	*7300		5400						*4800		4500
	Front dozer and rear stabilizer up						5950		4200	4100		2850						3400		2350
Front dozer and rear stabilizer down						*8600	*8600	6800	*7300	6500	4650						*4800	*4800	3850	
4500 mm	Front stabilizer and rear dozer up						9100		6500	5600		4100	3900					2850		2050
	Front stabilizer and rear dozer down						*11 100	*11 100	10 550	*8900	*8900	6500	*7350	4500				*4750	*4750	3350
	2 sets stabilizers up						9350		6550	5800		4100	4000					2950		2050
	2 sets stabilizers down						*11 100	*11 100	*8900	7750	*7350	5350						*4750		4000
	Front dozer and rear stabilizer up						9400		6500	5800		4100	4050					3000		2050
Front dozer and rear stabilizer down						*11 100	*11 100	10 850	*8900	*8900	6650	*7350	6450	4600				*4750	*4750	3400
3000 mm	Front stabilizer and rear dozer up	18 000			11 550	8600		6050	5400		3850	3750		2700	2800		1950	2650		1850
	Front stabilizer and rear dozer down	*18 000	*18 000	*18 000	*12 250	*12 250	10 000	*9300	*9300	6250	7400		7250	4400	5450	5400	3250	*4850	*4850	3100
	2 sets stabilizers up	18 000			11 700	8850		6100	5550		3900	3900		2750	2900		2000	2750		1900
	2 sets stabilizers down	*18 000			*12 250	*12 250	*12 250	*9300	5600		7500	*7400		5250	5600		3900	*4850		3700
	Front dozer and rear stabilizer up	18 000			11 550	8900		6050	5300		3850	3900		2700	2900		1950	2750		1850
Front dozer and rear stabilizer down	*18 000	*18 000	*18 000	*12 250	*12 250	10 300	*9300	9200	6400	*7400	6350	4500	*5750	4700	3350	*4850	4500		3200	
1500 mm	Front stabilizer and rear dozer up	*11 900			10 150	8050		5550	5150		3850	3850		2600	2750		1950	2600		1800
	Front stabilizer and rear dozer down	*11 900	*11 900	*11 900	*12 950	*12 950	9450	*9450	*9450	6000	*7250	7100	4250	*5300	*5300	3200	*4750	*4750		3050
	2 sets stabilizers up	*11 900			10 300	8250		5600	5300		3700	3750		2600	2850		1950	2700		1850
	2 sets stabilizers down	*11 900			*11 900	*12 950		11 650	*9450		7200	*7250		5100	*5300		3850	*4750		3650
	Front dozer and rear stabilizer up	*11 900			10 150	8300		5550	5350		3650	3800		2600	2850		1950	2700		1800
Front dozer and rear stabilizer down	*11 900	*11 900	*11 900	*12 950	*12 950	9700	*9450	8900	6150	*7250	6200	4350	*5300	4650	3300	*4750	4400		3100	
0 mm	Front stabilizer and rear dozer up	*6250			*6250	7600		5200	4950		3450	3550		2500						
	Front stabilizer and rear dozer down	*6250	*6250		*6250	*12 250	*12 250	9000	*8900	*8900	5800	*6600		4150						
	2 sets stabilizers up	*6250			*6250	7850		5250	5100		3500	3650		2550						
	2 sets stabilizers down	*6250			*6250	*12 250		11 200	*8900		7000	*6600		5000						
	Front dozer and rear stabilizer up	*6250			*6250	7900		5200	5150		3450	3700		2500						
Front dozer and rear stabilizer down	*6250	*6250	*6250	*12 250	*12 250	9300	*8900	8650	5900	*6600	6050	4250								
-1500 mm	Front stabilizer and rear dozer up					7450		5000	4800		3350									
	Front stabilizer and rear dozer down					*9850	*9850	8800	*7300	*7300	5650									
	2 sets stabilizers up					7700		5100	5000		3400									
	2 sets stabilizers down					*9850		*9850	*7300		6900									
	Front dozer and rear stabilizer up					7750		5000	5000		3350									
Front dozer and rear stabilizer down					*9850	*9850	9100	*7300	*7300	5800										

\*Limited by hydraulic rather than tipping load.

Lift capacity ratings are based on ISO 10567:2007, they do not exceed 87% of hydraulic lifting capacity or 75% of tipping load. The load point is the center line of the bucket pivot mounting pin on the stick. The oscillating axle must be locked. Lifting capacities are based on the machine standing on a firm uniform supporting surface. For lifting capacity including bucket and/or quick coupler, the respective weight has to be subtracted from above values. The use of a work tool attachment point to handle/lift objects, could affect the machine lift performance.

Always refer to the appropriate Operation and Maintenance Manual for specific product information.

# Material Handlers

## Lifting Capacities ● MH3022 (Grenoble Sourced)

### Lift Capacities

All values are in lb, bucket cylinder and linkage installed, without bucket, with counterweight (9260 lb), heavy lift on.

		Load point height	Load over front	Load over rear	Load over side	Load at maximum reach (sticknose/bucket pin)															
<b>Undercarriage</b>		<b>Boom</b>					<b>Stick</b>														
<b>Standard</b>		<b>17'7" MH</b>					<b>13'9" Straight Stick</b>														
	<b>Undercarriage configuration</b>	<b>10 ft</b>			<b>15 ft</b>			<b>20 ft</b>			<b>25 ft</b>			<b>30 ft</b>						<b>ft</b>	
30 ft	Front stabilizer and rear dozer up				*18,200	*18,200	14,100											*12,900	12,600	9700	18.73
	Front stabilizer and rear dozer down				*18,200	*18,200	*18,200											*12,900	*12,900	*12,900	
	2 sets stabilizers up				*18,200	*18,200	14,300											*12,900	12,500	9800	
	2 sets stabilizers down				*18,200	*18,200	*18,200											*12,900	*12,900	*12,900	
	Front dozer and rear stabilizers up				*18,200	17,900	14,100											*12,900	12,200	9700	
Front dozer and rear stabilizers down				*18,200	*18,200	*18,200												*12,900	*12,900	*12,900	
25 ft	Front stabilizer and rear dozer up							12,300	11,600	9000								8900	8500	6500	23.88
	Front stabilizer and rear dozer down							*17,600	*17,600	13,700								*11,300	*11,300	10,000	
	2 sets stabilizers up							12,600	11,600	9100								9200	8500	6500	
	2 sets stabilizers down							*17,600	*17,600	16,800								*11,300	*11,300	*11,300	
	Front dozer and rear stabilizers up							12,700	11,200	9000								9300	8200	6500	
Front dozer and rear stabilizers down							*17,600	*17,600	14,100								*11,300	*11,300	10,300		
20 ft	Front stabilizer and rear dozer up							12,200	11,600	8900	8300	8000	6000					7200	6800	5100	27.20
	Front stabilizer and rear dozer down							*18,700	*18,700	13,700	*15,500	*15,500	9400					*10,600	*10,600	8100	
	2 sets stabilizers up							12,600	11,500	9000	8600	7900	6100					7400	6800	5200	
	2 sets stabilizers down							*18,700	*18,700	16,800	*15,500	14,200	11,500					*10,600	*10,600	9900	
	Front dozer and rear stabilizers up							12,600	11,200	8900	8700	7600	6000					7400	6600	5100	
Front dozer and rear stabilizers down							*18,700	*18,700	14,100	*15,500	13,800	9600					*10,600	*10,600	8300		
15 ft	Front stabilizer and rear dozer up				19,300	18,100	13,800	11,900	11,300	8700	8200	7800	5900					6200	6000	4400	29.27
	Front stabilizer and rear dozer down				*24,000	*24,000	21,700	19,300	19,300	13,400	*16,000	15,700	9300					*10,500	*10,500	7100	
	2 sets stabilizers up				19,800	18,000	13,900	12,300	11,300	8800	8500	7800	6000					6500	5900	4500	
	2 sets stabilizers down				*24,000	*24,000	*24,000	19,300	19,300	16,500	*16,000	14,100	11,300					*10,500	*10,500	8700	
	Front dozer and rear stabilizers up				19,900	17,500	13,800	12,400	10,900	8700	8500	7500	5900					6500	5700	4400	
Front dozer and rear stabilizers down				*24,000	*24,000	22,400	19,300	19,300	13,800	*16,000	13,700	9500					*10,500	*10,500	7300		
10 ft	Front stabilizer and rear dozer up	38,100	34,200	24,600	18,300	17,100	12,900	11,500	10,900	8200	8000	7600	5700	5900	5600	4200	5800	5500	4100	30.35	
	Front stabilizer and rear dozer down	*38,800	*38,800	*38,800	*26,500	*26,500	20,600	*20,200	12,900	15,700	15,400	9000	11,600	11,400	6700	*10,700	*10,700	6600			
	2 sets stabilizers up	*38,800	34,000	24,900	18,800	17,000	13,000	11,800	10,800	8300	8300	7600	5800	6100	5600	4200	6000	5500	4100		
	2 sets stabilizers down	*38,800	*38,800	*38,800	*26,500	*26,500	26,100	*20,200	20,100	15,900	*16,000	13,900	11,100	11,900	10,300	8300	*10,700	10,100	8100		
	Front dozer and rear stabilizers up	*38,800	33,000	24,600	18,900	16,500	12,900	11,900	10,400	8200	8300	7300	5700	6200	5400	4200	6000	5300	4100		
Front dozer and rear stabilizers down	*38,800	*38,800	*38,800	*26,500	*26,500	21,300	*20,200	19,500	13,300	*16,000	13,400	9300	*12,000	10,000	6900	*10,700	9800	6800			
5 ft	Front stabilizer and rear dozer up	*29,500	*29,500	21,600	17,100	15,900	11,800	10,900	10,300	7700	7700	7400	5500	5800	5500	4100	5600	5400	3900	30.58	
	Front stabilizer and rear dozer down	*29,500	*29,500	*29,500	*28,000	*28,000	19,400	*20,500	*20,500	12,400	15,400	15,100	8800	*11,200	*11,200	6600	*10,500	*10,500	6400		
	2 sets stabilizers up	*29,500	*29,500	21,800	17,600	15,800	11,900	11,300	10,300	7800	8000	7300	5600	6000	5500	4100	5800	5300	4000		
	2 sets stabilizers down	*29,500	*29,500	*29,500	*28,000	*28,000	24,700	*20,500	19,500	15,400	*15,600	13,600	10,800	*11,200	10,200	8200	*10,500	9900	7900		
	Front dozer and rear stabilizers up	*29,500	*29,500	21,600	17,700	15,300	11,800	11,300	9900	7700	8100	7100	5500	6100	5300	4100	5900	5100	3900		
Front dozer and rear stabilizers down	*29,500	*29,500	*29,500	*28,000	*28,000	20,100	*20,500	18,900	12,700	*15,600	13,200	9000	*11,200	9900	6800	*10,500	9600	6600			
0 ft	Front stabilizer and rear dozer up	*14,400	*14,400	*14,400	16,200	15,100	11,000	10,500	9900	7300	7500	7200	5300								
	Front stabilizer and rear dozer down	*14,400	*14,400	*14,400	*26,600	*26,600	18,500	*19,200	11,900	*14,100	*14,100	8600									
	2 sets stabilizers up	*14,400	*14,400	*14,400	16,700	15,000	11,100	10,800	9800	7400	7800	7100	5300								
	2 sets stabilizers down	*14,400	*14,400	*14,400	*26,600	*26,600	23,700	*19,200	19,000	14,900	*14,100	13,300	10,600								
	Front dozer and rear stabilizers up	*14,400	*14,400	*14,400	16,800	14,500	11,000	10,900	9500	7300	7800	6900	5300								
Front dozer and rear stabilizers down	*14,400	*14,400	*14,400	*26,600	*26,600	19,100	*19,200	18,400	12,300	*14,100	12,900	8800									
-5 ft	Front stabilizer and rear dozer up				15,800	14,700	10,600	10,200	9700	7100											
	Front stabilizer and rear dozer down				*21,300	*21,300	18,100	*15,700	*15,700	11,700											
	2 sets stabilizers up				16,300	14,600	10,800	10,600	9600	7200											
	2 sets stabilizers down				*21,300	*21,300	*21,300	*15,700	*15,700	14,600											
	Front dozer and rear stabilizers up				16,400	14,100	10,600	10,700	9300	7100											
Front dozer and rear stabilizers down				*21,300	*21,300	18,700	*15,700	*15,700	12,000												

\*Limited by hydraulic rather than tipping load.

Lift capacity ratings are based on ISO 10567:2007, they do not exceed 87% of hydraulic lifting capacity or 75% of tipping load. The load point is the center line of the bucket pivot mounting pin on the stick. The oscillating axle must be locked. Lifting capacities are based on the machine standing on a firm uniform supporting surface. For lifting capacity including bucket and/or quick coupler, the respective weight has to be subtracted from above values. The use of a work tool attachment point to handle/lift objects, could affect the machine lift performance.

Always refer to the appropriate Operation and Maintenance Manual for specific product information.

Specifications  
Range Dimensions  
● MH3024  
(Grenoble Sourced)

**Material Handlers**

**MH3024 Specifications**

Model	MH3024	
Operating Weight	23 500-26 500 kg	51,809-58,422 lb
Rated Power (ISO 14396)	129 kW	173 hp
Engine Model	C7.1 ACERT	
Emissions	U.S. EPA Tier 4 Final, EU Stage IV, Japan 2014 (Tier 4 Final)	
Maximum Travel Speed	25 km/h	15.5 mph
Fuel Tank Refill Capacity	420 L	111.0 U.S. gal
Eye Level Height (Cab Fully Raised)	4850 mm	15'11"
Tail Swing Radius	2825 mm	9'3"

**MH3024 Range Diagram**

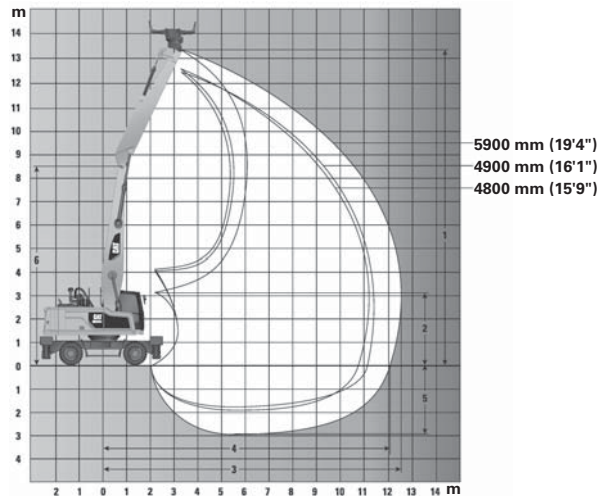

**Undercarriage**

**Special Application MH Undercarriage**

<b>Wheel Base</b>	2750 mm (9'0")				
<b>Width over Tires (10.00-20 Solid)</b>	2700 mm (8'10")				
<b>Boom – Boom Length</b>	Standard MH Boom – 6800 mm (22'4")				
<b>Stick – Stick Length</b>	MH Drop Nose Stick – 4900 mm (16'1")		MH Drop Nose Stick – 5900 mm (19'4")		MH Straight Stick – 4800 mm (15'9")
<b>1</b> Maximum Vertical Pin Height	12 500 mm	<b>41'0"</b>	13 300 mm	<b>43'8"</b>	12 400 mm <b>40'8"</b>
<b>2</b> Minimum Dump Height	4025 mm	<b>13'2"</b>	3090 mm	<b>10'1"</b>	4120 mm <b>13'6"</b>
<b>3</b> Maximum Horizontal Reach	11 500 mm	<b>37'9"</b>	12 500 mm	<b>41'0"</b>	11 400 mm <b>37'5"</b>
<b>4</b> Maximum Reach at Ground Level	10 850 mm	<b>35'7"</b>	12 050 mm	<b>39'6"</b>	11 250 mm <b>36'10"</b>
<b>5</b> Maximum Depth	1920 mm	<b>6'3"</b>	2925 mm	<b>9'7"</b>	1825 mm <b>5'11"</b>
<b>6</b> Boom Pin Height	8620 mm	<b>28'3"</b>	8620 mm	<b>28'3"</b>	8620 mm <b>28'3"</b>

### Lift Capacities

All values are in kg, bucket cylinder and linkage installed, hydraulic cab riser, work tool: none, with counterweight (4100 kg), heavy lift on.



#### Undercarriage

#### Boom

#### Stick

MH or Standard

One-Piece

2.5 m

Stick height	Undercarriage configuration	3000 mm			4500 mm			6000 mm			7500 mm			mm	
		Load over front	Load over rear	Load over side	Load over front	Load over rear	Load over side	Load over front	Load over rear	Load over side	Load over front	Load over rear	Load over side		
7500 mm	MH – stabilizers up – solid tires														
	MH – stabilizers down – solid tires														
	Lower (std UC) – f. stabilizer & r. dozer up														
	Lower (std UC) – f. stabilizer & r. dozer down														
	Lower (std UC) – f. dozer & r. stabilizer up														
	Lower (std UC) – f. dozer & r. stabilizer down														
	Lower (std UC) – 2 sets stabilizers up														
6000 mm	MH – stabilizers up – solid tires														
	MH – stabilizers down – solid tires														
	Lower (std UC) – f. stabilizer & r. dozer up														
	Lower (std UC) – f. stabilizer & r. dozer down														
	Lower (std UC) – f. dozer & r. stabilizer up														
	Lower (std UC) – f. dozer & r. stabilizer down														
	Lower (std UC) – 2 sets stabilizers up														
4500 mm	MH – stabilizers up – solid tires														
	MH – stabilizers down – solid tires														
	Lower (std UC) – f. stabilizer & r. dozer up														
	Lower (std UC) – f. stabilizer & r. dozer down														
	Lower (std UC) – f. dozer & r. stabilizer up														
	Lower (std UC) – f. dozer & r. stabilizer down														
	Lower (std UC) – 2 sets stabilizers up														
3000 mm	MH – stabilizers up – solid tires														
	MH – stabilizers down – solid tires														
	Lower (std UC) – f. stabilizer & r. dozer up														
	Lower (std UC) – f. stabilizer & r. dozer down														
	Lower (std UC) – f. dozer & r. stabilizer up														
	Lower (std UC) – f. dozer & r. stabilizer down														
	Lower (std UC) – 2 sets stabilizers up														
1500 mm	MH – stabilizers up – solid tires														
	MH – stabilizers down – solid tires														
	Lower (std UC) – f. stabilizer & r. dozer up														
	Lower (std UC) – f. stabilizer & r. dozer down														
	Lower (std UC) – f. dozer & r. stabilizer up														
	Lower (std UC) – f. dozer & r. stabilizer down														
	Lower (std UC) – 2 sets stabilizers up														
0 mm	MH – stabilizers up – solid tires														
	MH – stabilizers down – solid tires														
	Lower (std UC) – f. stabilizer & r. dozer up														
	Lower (std UC) – f. stabilizer & r. dozer down														
	Lower (std UC) – f. dozer & r. stabilizer up														
	Lower (std UC) – f. dozer & r. stabilizer down														
	Lower (std UC) – 2 sets stabilizers up														
-1500 mm	MH – stabilizers up – solid tires														
	MH – stabilizers down – solid tires														
	Lower (std UC) – f. stabilizer & r. dozer up														
	Lower (std UC) – f. stabilizer & r. dozer down														
	Lower (std UC) – f. dozer & r. stabilizer up														
	Lower (std UC) – f. dozer & r. stabilizer down														
	Lower (std UC) – 2 sets stabilizers up														
-3000 mm	MH – stabilizers up – solid tires														
	MH – stabilizers down – solid tires														
	Lower (std UC) – f. stabilizer & r. dozer up														
	Lower (std UC) – f. stabilizer & r. dozer down														
	Lower (std UC) – f. dozer & r. stabilizer up														
	Lower (std UC) – f. dozer & r. stabilizer down														
	Lower (std UC) – 2 sets stabilizers up														

\* Limited by hydraulic rather than tipping load.

Lift capacity ratings are based on ISO 10567:2007, they do not exceed 87% of hydraulic lifting capacity or 75% of tipping load. The load point is the center line of the bucket pivot mounting pin on the stick. The oscillating axle must be locked. Lifting capacities are based on the machine standing on a firm uniform supporting surface. For lifting capacity including bucket and/or quick coupler, the respective weight has to be subtracted from above values. The use of a work tool attachment point to handle/lift objects, could affect the machine lift performance.

Always refer to the appropriate Operation and Maintenance Manual for specific product information.

# Lifting Capacities • MH3024 (Grenoble Sourced)

# Material Handlers

## Lift Capacities

All values are in lb, bucket cylinder and linkage installed, hydraulic cab riser, work tool: none, with counterweight (9040 lb), heavy lift on.

 Load point height

 Load over front

 Load over rear

 Load over side















 Load at maximum reach (sticknose/bucket pin)

### Undercarriage

### Boom One-Piece

### Stick 8'2"

MH or Standard

Stick 8'2"	Undercarriage configuration	10 ft			15 ft			20 ft			25 ft			ft						
																				
25 ft	MH – stabilizers up – solid tires														*8400	*8400	*8400			
	MH – stabilizers down – solid tires														*8400	*8400	*8400			
	Lower (std UC) – f. stabilizer & r. dozer up														*8400	*8400	*8400			
	Lower (std UC) – f. stabilizer & r. dozer down														*8400	*8400	*8400			
	Lower (std UC) – f. dozer & r. stabilizer up														*8400	*8400	*8400			
	Lower (std UC) – f. dozer & r. stabilizer down														*8400	*8400	*8400			
	Lower (std UC) – 2 sets stabilizers up														*8400	*8400	*8400			
20 ft	MH – stabilizers up – solid tires							12,800	12,800	9600					*7400	*7400	7300			
	MH – stabilizers down – solid tires							*14,100	*14,100	*14,100					*7400	*7400	*7400			
	Lower (std UC) – f. stabilizer & r. dozer up							12,500	11,900	9200					*7400	*7400	6900			
	Lower (std UC) – f. stabilizer & r. dozer down							*14,100	*14,100	14,000					*7400	*7400	*7400			
	Lower (std UC) – f. dozer & r. stabilizer up							13,000	11,500	9200					*7400	*7400	6900			
	Lower (std UC) – f. dozer & r. stabilizer down							*14,100	*14,100	*14,100					*7400	*7400	*7400			
	Lower (std UC) – 2 sets stabilizers up							12,900	11,800	9300					*7400	*7400	7000			
15 ft	MH – stabilizers up – solid tires							*14,100	*14,100	*14,100					*7400	*7400	*7400			
	MH – stabilizers down – solid tires							12,500	12,500	9300	8700	8700	6500		*7100	*7100	6000			
	Lower (std UC) – f. stabilizer & r. dozer up							12,200	11,600	8800	8500	8100	6100		*7100	*7100	5700			
	Lower (std UC) – f. stabilizer & r. dozer down							*15,100	*15,100	13,700	*12,100	*12,100	9500		*7100	*7100	*7100			
	Lower (std UC) – f. dozer & r. stabilizer up							12,600	11,100	8800	8800	7800	6100		*7100	*7100	5700			
	Lower (std UC) – f. dozer & r. stabilizer down							*15,100	*15,100	14,100	*12,100	*12,100	9800		*7100	*7100	*7100			
	Lower (std UC) – 2 sets stabilizers up							12,500	11,500	8900	8700	8000	6200		*7100	*7100	5800			
10 ft	MH – stabilizers up – solid tires							*15,100	*15,100	*15,100	*12,100	*12,100	11,700		*7100	*7100	*7100			
	MH – stabilizers down – solid tires							18,200	18,200	13,100	11,900	11,900	8500	6300	*7100	*7100	5400			
	Lower (std UC) – f. stabilizer & r. dozer up							*22,400	*22,400	*22,400	*16,700	*16,700	*16,700	*14,000	13,700	*7100	*7100			
	Lower (std UC) – f. stabilizer & r. dozer down							18,000	16,700	12,500	11,600	11,000	8300	7900	5900	*7100	6900	5100		
	Lower (std UC) – f. dozer & r. stabilizer up							*22,400	*22,400	20,300	*16,700	*16,700	13,100	*14,000	*14,000	9300	*7100	*7100		
	Lower (std UC) – f. dozer & r. stabilizer down							18,600	16,200	12,500	12,100	10,600	8300	8600	7600	5900	*7100	6600	5100	
	Lower (std UC) – 2 sets stabilizers up							*22,400	*22,400	21,000	*16,700	*16,700	13,500	*14,000	13,800	9600	*7100	*7100		
5 ft	MH – stabilizers up – solid tires							18,500	16,700	12,600	12,000	11,000	8400	8500	7800	6000	*7100	6800	5200	
	MH – stabilizers down – solid tires							*22,400	*22,400	*22,400	*16,700	*16,700	16,200	*14,000	*14,000	11,400	*7100	*7100		
	Lower (std UC) – f. stabilizer & r. dozer up							17,100	17,100	12,100	11,400	11,400	8300	8300	6300	6000	7200	5200		
	Lower (std UC) – f. stabilizer & r. dozer down							*25,400	*25,400	*25,400	*18,200	*18,200	*14,500	*14,500	13,400	*7400	*7400	*7400		
	Lower (std UC) – f. dozer & r. stabilizer up							16,800	15,700	11,500	11,100	10,500	7800	8000	7600	5700	7000	6600	4900	
	Lower (std UC) – f. dozer & r. stabilizer down							*25,400	*25,400	19,200	*18,200	*18,200	12,600	*14,500	13,000	9100	*7400	*7400	*7400	
	Lower (std UC) – 2 sets stabilizers up							17,400	15,100	11,500	11,500	10,100	7800	8400	7300	5700	7200	6400	4900	
0 ft	MH – stabilizers up – solid tires							*25,400	*25,400	19,900	*18,200	*18,200	12,900	*14,500	13,600	9300	*7400	*7400	*7400	
	MH – stabilizers down – solid tires							17,300	15,600	11,600	11,400	10,400	7900	8300	7600	5800	7200	6600	5000	
	Lower (std UC) – f. stabilizer & r. dozer up							*25,400	*25,400	24,500	*18,200	*18,200	15,600	*14,500	14,000	11,200	*7400	*7400	*7400	
	Lower (std UC) – f. stabilizer & r. dozer down							16,800	16,600	11,600	11,000	11,000	7900	8100	8100	5900	7400	7400	5300	
	Lower (std UC) – f. dozer & r. stabilizer up							*25,700	*25,700	*25,700	*18,700	*18,700	18,500	*14,400	*14,400	13,200	*8100	*8100	*8100	
	Lower (std UC) – f. dozer & r. stabilizer down							16,300	15,200	11,000	10,700	10,100	7500	7900	7500	5500	7100	6800	5000	
	Lower (std UC) – 2 sets stabilizers up							*25,700	*25,700	18,600	*18,700	*18,700	12,200	*14,400	*14,400	8900	*8100	*8100	8100	
-5 ft	MH – stabilizers up – solid tires							16,900	14,600	11,000	11,200	9700	7500	8200	7200	5500	7400	6500	5000	
	MH – stabilizers down – solid tires							*25,700	*25,700	19,300	*18,700	*18,700	12,600	*14,400	13,400	9100	*8100	*8100	*8100	
	Lower (std UC) – f. stabilizer & r. dozer up							16,800	15,100	11,200	11,100	10,100	7600	8100	7400	5600	7400	6700	5100	
	Lower (std UC) – f. stabilizer & r. dozer down							*25,700	*25,700	24,000	*18,700	*18,700	15,200	*14,400	13,800	11,000	*8100	*8100	*8100	
	Lower (std UC) – f. dozer & r. stabilizer up							*22,200	*22,200	21,500	16,500	16,500	11,600	10,900	7800	8100	8100	5900	8000	5800
	Lower (std UC) – f. dozer & r. stabilizer down							*22,200	*22,200	*23,800	*23,800	*23,800	*17,700	*17,700	*11,300	*11,300	*11,300	*9500	*9500	*9500
	Lower (std UC) – 2 sets stabilizers up							16,200	15,100	11,000	10,600	10,000	7400	7800	7500	5500	7800	7400	5500	
-10 ft	MH – stabilizers up – solid tires							*22,200	*22,200	*23,800	*23,800	*23,800	*17,700	*17,700	12,100	*11,300	*11,300	8900	*9500	8800
	MH – stabilizers down – solid tires							16,900	14,500	11,000	11,000	9600	7400	8200	7100	5500	8100	7100	5500	
	Lower (std UC) – f. stabilizer & r. dozer up							*22,200	*22,200	*23,800	*23,800	*23,800	*17,700	*17,700	12,400	*11,300	*11,300	9100	*9500	9100
	Lower (std UC) – f. stabilizer & r. dozer down							16,700	15,000	11,100	11,000	10,000	7500	8100	7400	5600	8000	7400	5600	
	Lower (std UC) – 2 sets stabilizers up							*22,200	*22,200	*23,800	*23,800	*23,800	*17,700	*17,700	15,100	*11,300	*11,300	11,000	*9500	*9500
	Lower (std UC) – f. stabilizer & r. dozer up							*25,700	*25,700	21,900	16,700	16,700	11,800	11,000	7900		9700	9700	7000	
	Lower (std UC) – f. stabilizer & r. dozer down							*25,700	*25,700	*25,700	*19,800	*19,800	*14,500	*14,500	*14,500		*11,800	*11,800	*11,800	

\*Limited by hydraulic rather than tipping load.

Lift capacity ratings are based on ISO 10567:2007, they do not exceed 87% of hydraulic lifting capacity or 75% of tipping load. The load point is the center line of the bucket pivot mounting pin on the stick. The oscillating axle must be locked. Lifting capacities are based on the machine standing on a firm uniform supporting surface. For lifting capacity including bucket and/or quick coupler, the respective weight has to be subtracted from above values. The use of a work tool attachment point to handle/lift objects, could affect the machine lift performance.

Always refer to the appropriate Operation and Maintenance Manual for specific product information.

### Lift Capacities

All values are in kg, bucket cylinder and linkage installed, hydraulic cab riser, work tool: none, with counterweight (5200 kg), heavy lift on.

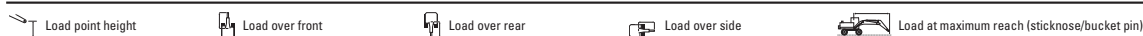

Undercarriage		Boom						Stick										
MH or Standard		One-Piece						2.5 m										
Stick height	Undercarriage configuration	3000 mm		4500 mm		6000 mm		7500 mm		Stick		mm						
		Load over front	Load over rear	Load over front	Load over rear	Load over front	Load over rear	Load over front	Load over rear	Load at maximum reach	mm							
7500 mm	MH – stabilizers up – solid tires					*3950	*3950	*3950				*3750	*3750	*3750				
	MH – stabilizers down – solid tires					*3950	*3950	*3950				*3750	*3750	*3750				
	Lower (std UC) – f. stabilizer & r. dozer up					*3950	*3950	*3950				*3750	*3750	*3750				
	Lower (std UC) – f. stabilizer & r. dozer down					*3950	*3950	*3950				*3750	*3750	*3750				
	Lower (std UC) – f. dozer & r. stabilizer up					*3950	*3950	*3950				*3750	*3750	*3750				
	Lower (std UC) – f. dozer & r. stabilizer down					*3950	*3950	*3950				*3750	*3750	*3750				
	Lower (std UC) – 2 sets stabilizers up					*3950	*3950	*3950				*3750	*3750	*3750				
6000 mm	MH – stabilizers up – solid tires					*6400	*6400	*6400				*3350	*3350	*3350				
	MH – stabilizers down – solid tires					*6400	*6400	*6400				*3350	*3350	*3350				
	Lower (std UC) – f. stabilizer & r. dozer up					*6400	*6400	*6400				*3350	*3350	*3350				
	Lower (std UC) – f. stabilizer & r. dozer down					*6400	*6400	*6400				*3350	*3350	*3350				
	Lower (std UC) – f. dozer & r. stabilizer up					*6400	*6400	*6400				*3350	*3350	*3350				
	Lower (std UC) – f. dozer & r. stabilizer down					*6400	*6400	*6400				*3350	*3350	*3350				
	Lower (std UC) – 2 sets stabilizers up					*6400	*6400	*6400				*3350	*3350	*3350				
4500 mm	MH – stabilizers up – solid tires					6450	6450	4900	4600	4600	3450	*3200	*3200	3150				
	MH – stabilizers down – solid tires					*6950	*6950	*6950	*6150	*6150	3200	*3200	*3200	*3200				
	Lower (std UC) – f. stabilizer & r. dozer up					6400	6000	4700	4500	4250	3300	*3200	*3200	3000				
	Lower (std UC) – f. stabilizer & r. dozer down					*6950	*6950	*6950	*6150	*6150	5000	*3200	*3200	*3200				
	Lower (std UC) – f. dozer & r. stabilizer up					6550	5850	4700	4650	4100	3300	*3200	*3200	3000				
	Lower (std UC) – f. dozer & r. stabilizer down					*6950	*6950	*6950	*6150	*6150	5100	*3200	*3200	*3200				
	Lower (std UC) – 2 sets stabilizers up					6550	6000	4750	4600	4250	3350	*3200	*3200	3050				
3000 mm	MH – stabilizers up – solid tires			9450	9450	6900	6200	6200	4650	4500	3350	*3200	*3200	2850				
	MH – stabilizers down – solid tires			*10 400	*10 400	*10 400	*7750	*7750	*7750	*6400	*6400	*6400	*3200	*3200	*3200			
	Lower (std UC) – f. stabilizer & r. dozer up			9400	8750	6650	6100	5750	4450	4400	4150	3200	*3200	2750				
	Lower (std UC) – f. stabilizer & r. dozer down			*10 400	*10 400	*10 400	*7750	*7750	6850	*6400	4900	*3200	*3200	*3200				
	Lower (std UC) – f. dozer & r. stabilizer up			9700	8450	6650	6300	5600	4450	4550	4000	3200	*3200	2750				
	Lower (std UC) – f. dozer & r. stabilizer down			*10 400	*10 400	*10 400	*7750	*7750	7000	*6400	5000	*3200	*3200	*3200				
	Lower (std UC) – 2 sets stabilizers up			9650	8700	6700	6250	5750	4500	4500	4150	3250	*3200	*3200	2750			
1500 mm	MH – stabilizers up – solid tires			8950	8950	6450	5950	5950	4400	4350	3250	*3200	*3200	2750				
	MH – stabilizers down – solid tires			*11 750	*11 750	*11 750	*8400	*8400	*8400	*6700	*6700	*6700	*3200	*3200	*3200			
	Lower (std UC) – f. stabilizer & r. dozer up			8850	8250	6150	5850	5550	4200	4250	4050	3100	*3200	*3200	2650			
	Lower (std UC) – f. stabilizer & r. dozer down			*11 750	*11 750	10 000	*8400	*8400	6550	*6700	*6700	4750	*3200	*3200	*3200			
	Lower (std UC) – f. dozer & r. stabilizer up			9150	7950	6150	6050	5350	4200	4400	3900	3100	*3200	*3200	2650			
	Lower (std UC) – f. dozer & r. stabilizer down			*11 750	*11 750	10 350	*8400	*8400	6750	*6700	*6700	4900	*3200	*3200	*3200			
	Lower (std UC) – 2 sets stabilizers up			9100	8200	6250	6000	5500	4250	4400	4050	3150	*3200	*3200	2650			
0 mm	MH – stabilizers up – solid tires			8750	8750	6250	5800	5800	4250	4300	3150	*3700	*3700	2800				
	MH – stabilizers down – solid tires			*11 850	*11 850	*11 850	*8600	*8600	*8600	*6650	*6650	*3700	*3700	*3700				
	Lower (std UC) – f. stabilizer & r. dozer up			8650	8000	5950	5700	5350	4050	4200	3950	3000	*3700	*3700	2700			
	Lower (std UC) – f. stabilizer & r. dozer down			*11 850	*11 850	9800	*8600	*8600	6400	*6650	4700	*3700	*3700	*3700				
	Lower (std UC) – f. dozer & r. stabilizer up			8950	7750	5950	5900	5200	4050	4300	3800	3000	*3700	*3700	2700			
	Lower (std UC) – f. dozer & r. stabilizer down			*11 850	*11 850	10 150	*8600	*8600	6600	*6650	4800	*3700	*3700	*3700				
	Lower (std UC) – 2 sets stabilizers up			8900	8000	6050	5850	5350	4100	4300	3950	3050	*3700	*3700	2700			
-1500 mm	MH – stabilizers up – solid tires			*9750	*9750	*9750	8700	8700	6200	5750	5750	4200	4250	3150	4150	4150	3050	
	MH – stabilizers down – solid tires			*9750	*9750	*9750	*11 000	*11 000	*11 000	*8200	*8200	*6050	*6050	*6050	*4300	*4300	*4300	
	Lower (std UC) – f. stabilizer & r. dozer up			*9750	*9750	*9750	8600	8000	5950	5650	5300	4000	4150	3950	3000	4050	3850	2950
	Lower (std UC) – f. stabilizer & r. dozer down			*9750	*9750	*9750	*11 000	*11 000	9750	*8200	*8200	6350	*6050	*6050	4650	*4300	*4300	*4300
	Lower (std UC) – f. dozer & r. stabilizer up			*9750	*9750	*9750	8900	7700	5950	5850	5100	4000	4300	3800	3000	4200	3700	2950
	Lower (std UC) – f. dozer & r. stabilizer down			*9750	*9750	*9750	*11 000	*11 000	10 100	*8200	*8200	6550	*6050	*6050	4800	*4300	*4300	*4300
	Lower (std UC) – 2 sets stabilizers up			*9750	*9750	*9750	8850	7950	6000	5800	5300	4050	4300	3950	3050	4150	3800	2950
-3000 mm	MH – stabilizers up – solid tires			*11 850	*11 850	*11 850	*11 000	*11 000	*11 000	*8200	*8200	*6050	*6050	5700	*4300	*4300	*4300	
	MH – stabilizers down – solid tires			*11 850	*11 850	*11 850	*11 850	*11 850	*11 850	*9200	*9200	*6800	*6800	*6800	*5350	*5350	*5350	
	Lower (std UC) – f. stabilizer & r. dozer up			*11 850	*11 850	*11 850	*11 850	*11 850	*11 850	*11 850	*11 850	*11 850	*11 850	*11 850	*11 850	*11 850	*11 850	
	Lower (std UC) – f. stabilizer & r. dozer down			*11 850	*11 850	*11 850	*11 850	*11 850	*11 850	*11 850	*11 850	*11 850	*11 850	*11 850	*11 850	*11 850	*11 850	
	Lower (std UC) – f. dozer & r. stabilizer up			*11 850	*11 850	*11 850	*11 850	*11 850	*11 850	*11 850	*11 850	*11 850	*11 850	*11 850	*11 850	*11 850	*11 850	
	Lower (std UC) – f. dozer & r. stabilizer down			*11 850	*11 850	*11 850	*11 850	*11 850	*11 850	*11 850	*11 850	*11 850	*11 850	*11 850	*11 850	*11 850	*11 850	
	Lower (std UC) – 2 sets stabilizers up			*11 850	*11 850	*11 850	*11 850	*11 850	*11 850	*11 850	*11 850	*11 850	*11 850	*11 850	*11 850	*11 850	*11 850	

\* Limited by hydraulic rather than tipping load.

Lift capacity ratings are based on ISO 10567:2007, they do not exceed 87% of hydraulic lifting capacity or 75% of tipping load. The load point is the center line of the bucket pivot mounting pin on the stick. The oscillating axle must be locked. Lifting capacities are based on the machine standing on a firm uniform supporting surface. For lifting capacity including bucket and/or quick coupler, the respective weight has to be subtracted from above values. The use of a work tool attachment point to handle/lift objects, could affect the machine lift performance.

Always refer to the appropriate Operation and Maintenance Manual for specific product information.

# Lifting Capacities ● MH3024 (Grenoble Sourced)

# Material Handlers

## Lift Capacities

All values are in lb, bucket cylinder and linkage installed, hydraulic cab riser, work tool: none, with counterweight (11,470 lb), heavy lift on.

Load point height

Load over front

Load over rear

Load over side

Load at maximum reach (sticknose/bucket pin)

### Undercarriage

### Boom One-Piece

### Stick 8'2"

MH or Standard

Stick ft	Undercarriage configuration	10 ft			15 ft			20 ft			25 ft			ft		
25 ft	MH – stabilizers up – solid tires													*8400	*8400	*8400
	MH – stabilizers down – solid tires													*8400	*8400	*8400
	Lower (std UC) – f. stabilizer & r. dozer up													*8400	*8400	*8400
	Lower (std UC) – f. stabilizer & r. dozer down													*8400	*8400	*8400
	Lower (std UC) – f. dozer & r. stabilizer up													*8400	*8400	*8400
	Lower (std UC) – f. dozer & r. stabilizer down													*8400	*8400	*8400
	Lower (std UC) – 2 sets stabilizers up													*8400	*8400	*8400
20 ft	MH – stabilizers up – solid tires							*14,100	*14,100	10,900				*7400	*7400	*7400
	MH – stabilizers down – solid tires							*14,100	*14,100	*14,100				*7400	*7400	*7400
	Lower (std UC) – f. stabilizer & r. dozer up							*14,100	13,300	10,400				*7400	*7400	*7400
	Lower (std UC) – f. stabilizer & r. dozer down							*14,100	*14,100	*14,100				*7400	*7400	*7400
	Lower (std UC) – f. dozer & r. stabilizer up							*14,100	12,900	10,400				*7400	*7400	*7400
	Lower (std UC) – f. dozer & r. stabilizer down							*14,100	*14,100	*14,100				*7400	*7400	*7400
	Lower (std UC) – 2 sets stabilizers up							*14,100	13,300	10,500				*7400	*7400	*7400
15 ft	MH – stabilizers up – solid tires							13,900	13,900	10,500	9900	9900	7400	*7100	*7100	7000
	MH – stabilizers down – solid tires							*15,100	*15,100	*15,100	*12,100	*12,100	*12,100	*7100	*7100	*7100
	Lower (std UC) – f. stabilizer & r. dozer up							13,700	13,000	10,100	9600	9200	7100	*7100	*7100	6700
	Lower (std UC) – f. stabilizer & r. dozer down							*15,100	*15,100	*15,100	*12,100	*12,100	10,800	*7100	*7100	*7100
	Lower (std UC) – f. dozer & r. stabilizer up							14,200	12,600	10,100	10,000	8900	7100	*7100	*7100	6700
	Lower (std UC) – f. dozer & r. stabilizer down							*15,100	*15,100	*15,100	*12,100	*12,100	11,000	*7100	*7100	*7100
	Lower (std UC) – 2 sets stabilizers up							14,100	12,900	10,200	9900	9100	7200	*7100	*7100	6700
10 ft	MH – stabilizers up – solid tires				20,400	20,400	14,900	13,400	13,400	10,000	9700	9700	7200	*7100	*7100	6300
	MH – stabilizers down – solid tires				*22,400	*22,400	*22,400	*16,700	*16,700	*16,700	*14,000	*14,000	*14,000	*7100	*7100	*7100
	Lower (std UC) – f. stabilizer & r. dozer up				20,300	18,800	14,300	13,200	12,400	9600	9400	9000	6900	*7100	*7100	6000
	Lower (std UC) – f. stabilizer & r. dozer down				*22,400	*22,400	*22,400	*16,700	*16,700	14,700	*14,000	*14,000	10,500	*7100	*7100	*7100
	Lower (std UC) – f. dozer & r. stabilizer up				20,900	18,300	14,300	13,600	12,000	9600	9800	8700	6700	*7100	*7100	6000
	Lower (std UC) – f. dozer & r. stabilizer down				*22,400	*22,400	*22,400	*16,700	*16,700	15,100	*14,000	*14,000	10,800	*7100	*7100	*7100
	Lower (std UC) – 2 sets stabilizers up				20,800	18,800	14,500	13,500	12,400	9700	8900	7900	6900	*7100	*7100	6100
5 ft	MH – stabilizers up – solid tires				19,300	18,300	13,300	12,300	12,300	9500	9400	9400	7000	*7400	*7400	6100
	MH – stabilizers down – solid tires				*25,400	*25,400	*25,400	*18,200	*18,200	*14,500	*14,500	*14,500	*14,500	*7400	*7400	*7400
	Lower (std UC) – f. stabilizer & r. dozer up				19,100	17,800	13,300	12,600	11,900	9100	9200	8700	6700	*7400	*7400	5800
	Lower (std UC) – f. stabilizer & r. dozer down				*25,400	*25,400	21,600	*18,200	*18,200	14,200	*14,500	10,300	*7400	*7400	*7400	
	Lower (std UC) – f. dozer & r. stabilizer up				19,700	17,200	13,300	13,100	11,500	9100	9500	8400	6700	*7400	*7400	5800
	Lower (std UC) – f. dozer & r. stabilizer down				*25,400	*25,400	22,300	*18,200	*18,200	14,600	*14,500	10,500	*7400	*7400	*7400	
	Lower (std UC) – 2 sets stabilizers up				19,600	17,700	13,500	13,000	11,900	9200	9500	8700	6800	*7400	*7400	5900
0 ft	MH – stabilizers up – solid tires				18,800	18,800	13,500	12,500	12,500	9200	9200	9200	6800	*8100	*8100	6200
	MH – stabilizers down – solid tires				*25,700	*25,700	*25,700	*18,700	*18,700	*18,700	*14,400	*14,400	*14,400	*8100	*8100	*8100
	Lower (std UC) – f. stabilizer & r. dozer up				18,600	17,300	12,900	12,300	11,600	8800	9000	8600	6500	*8100	*8100	5900
	Lower (std UC) – f. stabilizer & r. dozer down				*25,700	*25,700	21,100	*18,700	*18,700	13,800	*14,400	*14,400	10,100	*8100	*8100	*8100
	Lower (std UC) – f. dozer & r. stabilizer up				19,200	16,700	12,900	12,700	11,200	8800	9300	8200	6500	*8100	*8100	5900
	Lower (std UC) – f. dozer & r. stabilizer down				*25,700	*25,700	21,800	*18,700	*18,700	14,200	*14,400	*14,400	10,400	*8100	*8100	*8100
	Lower (std UC) – 2 sets stabilizers up				19,100	17,200	13,000	12,600	11,500	8900	9300	8500	6600	*8100	*8100	6000
-5 ft	MH – stabilizers up – solid tires				*22,200	*22,200	*22,200	18,700	18,700	13,400	12,400	9100	9200	6800	9200	6800
	MH – stabilizers down – solid tires				*22,200	*22,200	*22,200	*23,800	*23,800	*17,700	*17,700	*11,300	*11,300	*11,300	*9500	*9500
	Lower (std UC) – f. stabilizer & r. dozer up				*22,200	*22,200	*22,200	18,500	17,200	12,800	12,200	11,500	8700	9000	8500	6500
	Lower (std UC) – f. stabilizer & r. dozer down				*22,200	*22,200	*22,200	*23,800	*23,800	21,000	*17,700	*17,700	13,700	*11,300	*11,300	*9500
	Lower (std UC) – f. dozer & r. stabilizer up				*22,200	*22,200	*22,200	19,100	16,600	12,800	12,600	11,100	8700	9300	8200	6500
	Lower (std UC) – f. dozer & r. stabilizer down				*22,200	*22,200	*22,200	*23,800	*23,800	21,700	*17,700	*17,700	14,100	*11,300	*11,300	*9500
	Lower (std UC) – 2 sets stabilizers up				*22,200	*22,200	*22,200	19,000	17,100	12,900	12,500	11,400	8800	9300	8500	6600
-10 ft	MH – stabilizers up – solid tires				*25,700	*25,700	25,100	18,900	18,900	13,600	12,500	12,500	9200		11,000	11,000
	MH – stabilizers down – solid tires				*25,700	*25,700	*25,700	*19,800	*19,800	*19,800	*14,500	*14,500	*14,500		*11,800	*11,800
	Lower (std UC) – f. stabilizer & r. dozer up				*25,700	*25,700	24,000	18,700	17,400	13,000	12,300	11,600	8800		10,800	10,200
	Lower (std UC) – f. stabilizer & r. dozer down				*25,700	*25,700	*25,700	*19,800	*19,800	*19,800	*14,500	*14,500	13,800		*11,800	*11,800
	Lower (std UC) – f. dozer & r. stabilizer up				*25,700	*25,700	24,000	19,300	16,800	13,000	12,700	11,200	8800		11,200	9800
	Lower (std UC) – f. dozer & r. stabilizer down				*25,700	*25,700	*25,700	*19,800	*19,800	*19,800	*14,500	*14,500	14,200		*11,800	*11,800
	Lower (std UC) – 2 sets stabilizers up				*25,700	*25,700	24,300	19,200	17,300	13,100	12,600	11,500	8900		11,100	10,200

\*Limited by hydraulic rather than tipping load.

Lift capacity ratings are based on ISO 10567:2007, they do not exceed 87% of hydraulic lifting capacity or 75% of tipping load. The load point is the center line of the bucket pivot mounting pin on the stick. The oscillating axle must be locked. Lifting capacities are based on the machine standing on a firm uniform supporting surface. For lifting capacity including bucket and/or quick coupler, the respective weight has to be subtracted from above values. The use of a work tool attachment point to handle/lift objects, could affect the machine lift performance.

Always refer to the appropriate Operation and Maintenance Manual for specific product information.



### Lift Capacities

All values are in kg, bucket cylinder and linkage installed, hydraulic cab riser, work tool: none, with counterweight (4100 kg), heavy lift on.

		Load point height			Load over front			Load over rear			Load over side			Load at maximum reach (sticknose/bucket pin)					
Undercarriage		Boom									Stick								
MH or Standard		3000 mm			4500 mm			6000 mm			7500 mm			2.9 m			mm		
	Undercarriage configuration																mm		
7500 mm	MH – stabilizers up – solid tires														*3050	*3050	*3050	6560	
	MH – stabilizers down – solid tires														*3050	*3050	*3050		
	Lower (std UC) – f. stabilizer & r. dozer up														*3050	*3050	*3050		
	Lower (std UC) – f. stabilizer & r. dozer down														*3050	*3050	*3050		
	Lower (std UC) – f. dozer & r. stabilizer up														*3050	*3050	*3050		
	Lower (std UC) – f. dozer & r. stabilizer down														*3050	*3050	*3050		
	Lower (std UC) – 2 sets stabilizers up														*3050	*3050	*3050		
6000 mm	MH – stabilizers up – solid tires												*3850	*3850	3050	*2750	*2750	*2750	7660
	MH – stabilizers down – solid tires												*3850	*3850	2900	*2750	*2750	*2750	
	Lower (std UC) – f. stabilizer & r. dozer up												*3850	*3850	2900	*2750	*2750	*2750	
	Lower (std UC) – f. stabilizer & r. dozer down												*3850	*3850	2900	*2750	*2750	*2750	
	Lower (std UC) – f. dozer & r. stabilizer up												*3850	*3850	2900	*2750	*2750	*2750	
	Lower (std UC) – f. dozer & r. stabilizer down												*3850	*3850	2900	*2750	*2750	*2750	
	Lower (std UC) – 2 sets stabilizers up												*3850	*3850	2900	*2750	*2750	*2750	
4500 mm	MH – stabilizers up – solid tires																		8340
	MH – stabilizers down – solid tires																		
	Lower (std UC) – f. stabilizer & r. dozer up																		
	Lower (std UC) – f. stabilizer & r. dozer down																		
	Lower (std UC) – f. dozer & r. stabilizer up																		
	Lower (std UC) – f. dozer & r. stabilizer down																		
	Lower (std UC) – 2 sets stabilizers up																		
3000 mm	MH – stabilizers up – solid tires																		8690
	MH – stabilizers down – solid tires																		
	Lower (std UC) – f. stabilizer & r. dozer up																		
	Lower (std UC) – f. stabilizer & r. dozer down																		
	Lower (std UC) – f. dozer & r. stabilizer up																		
	Lower (std UC) – f. dozer & r. stabilizer down																		
	Lower (std UC) – 2 sets stabilizers down																		
1500 mm	MH – stabilizers up – solid tires																		8770
	MH – stabilizers down – solid tires																		
	Lower (std UC) – f. stabilizer & r. dozer up																		
	Lower (std UC) – f. stabilizer & r. dozer down																		
	Lower (std UC) – f. dozer & r. stabilizer up																		
	Lower (std UC) – f. dozer & r. stabilizer down																		
	Lower (std UC) – 2 sets stabilizers down																		
0 mm	MH – stabilizers up – solid tires																		8580
	MH – stabilizers down – solid tires																		
	Lower (std UC) – f. stabilizer & r. dozer up																		
	Lower (std UC) – f. stabilizer & r. dozer down																		
	Lower (std UC) – f. dozer & r. stabilizer up																		
	Lower (std UC) – f. dozer & r. stabilizer down																		
	Lower (std UC) – 2 sets stabilizers down																		
-1500 mm	MH – stabilizers up – solid tires																		8100
	MH – stabilizers down – solid tires																		
	Lower (std UC) – f. stabilizer & r. dozer up																		
	Lower (std UC) – f. stabilizer & r. dozer down																		
	Lower (std UC) – f. dozer & r. stabilizer up																		
	Lower (std UC) – f. dozer & r. stabilizer down																		
	Lower (std UC) – 2 sets stabilizers down																		
-3000 mm	MH – stabilizers up – solid tires																		7260
	MH – stabilizers down – solid tires																		
	Lower (std UC) – f. stabilizer & r. dozer up																		
	Lower (std UC) – f. stabilizer & r. dozer down																		
	Lower (std UC) – f. dozer & r. stabilizer up																		
	Lower (std UC) – f. dozer & r. stabilizer down																		
	Lower (std UC) – 2 sets stabilizers down																		

\* Limited by hydraulic rather than tipping load.

Lift capacity ratings are based on ISO 10567:2007, they do not exceed 87% of hydraulic lifting capacity or 75% of tipping load. The load point is the center line of the bucket pivot mounting pin on the stick. The oscillating axle must be locked. Lifting capacities are based on the machine standing on a firm uniform supporting surface. For lifting capacity including bucket and/or quick coupler, the respective weight has to be subtracted from above values. The use of a work tool attachment point to handle/lift objects, could affect the machine lift performance.

Always refer to the appropriate Operation and Maintenance Manual for specific product information.

**Lift Capacities**

All values are in lb, bucket cylinder and linkage installed, hydraulic cab riser, work tool: none, with counterweight (9040 lb), heavy lift on.

		Load point height			Load over front			Load over rear			Load over side			Load at maximum reach (sticknose/bucket pin)					
<b>Undercarriage</b>		<b>Boom</b>									<b>Stick</b>								
<b>MH or Standard</b>		10 ft			15 ft			20 ft			25 ft					ft			
<b>Undercarriage configuration</b>																		ft	
25 ft	MH – stabilizers up – solid tires																	6900	
	MH – stabilizers down – solid tires																	6900	
	Lower (std UC) – f. stabilizer & r. dozer up																	6900	
	Lower (std UC) – f. stabilizer & r. dozer down																	6900	
	Lower (std UC) – f. dozer & r. stabilizer up																	6900	
	Lower (std UC) – f. dozer & r. stabilizer down																	6900	
20 ft	MH – stabilizers up – solid tires																	6100	
	MH – stabilizers down – solid tires																	6100	
	Lower (std UC) – f. stabilizer & r. dozer up																	6100	
	Lower (std UC) – f. stabilizer & r. dozer down																	6100	
	Lower (std UC) – f. dozer & r. stabilizer up																	6100	
	Lower (std UC) – f. dozer & r. stabilizer down																	6100	
15 ft	MH – stabilizers up – solid tires																	5900	
	MH – stabilizers down – solid tires																	5900	
	Lower (std UC) – f. stabilizer & r. dozer up																	5900	
	Lower (std UC) – f. stabilizer & r. dozer down																	5900	
	Lower (std UC) – f. dozer & r. stabilizer up																	5900	
	Lower (std UC) – f. dozer & r. stabilizer down																	5900	
10 ft	MH – stabilizers up – solid tires																	5500	
	MH – stabilizers down – solid tires																	5500	
	Lower (std UC) – f. stabilizer & r. dozer up																	5500	
	Lower (std UC) – f. stabilizer & r. dozer down																	5500	
	Lower (std UC) – f. dozer & r. stabilizer up																	5500	
	Lower (std UC) – f. dozer & r. stabilizer down																	5500	
5 ft	MH – stabilizers up – solid tires																	4800	
	MH – stabilizers down – solid tires																	4800	
	Lower (std UC) – f. stabilizer & r. dozer up																	4800	
	Lower (std UC) – f. stabilizer & r. dozer down																	4800	
	Lower (std UC) – f. dozer & r. stabilizer up																	4800	
	Lower (std UC) – f. dozer & r. stabilizer down																	4800	
0 ft	MH – stabilizers up – solid tires																	4900	
	MH – stabilizers down – solid tires																	4900	
	Lower (std UC) – f. stabilizer & r. dozer up																	4900	
	Lower (std UC) – f. stabilizer & r. dozer down																	4900	
	Lower (std UC) – f. dozer & r. stabilizer up																	4900	
	Lower (std UC) – f. dozer & r. stabilizer down																	4900	
-5 ft	MH – stabilizers up – solid tires	*21,000	*21,000	*21,000	16,400	16,400	11,400	10,800	10,800	7,700	7,900	7,900	5,700	7,400	7,400	5,300		5300	
	MH – stabilizers down – solid tires	*21,000	*21,000	*21,000	*24,400	*24,400	*24,400	*18,000	*18,000	*18,000	*13,500	*13,500	13,100	*7,700	*7,700	*7,700		7700	
	Lower (std UC) – f. stabilizer & r. dozer up	*21,000	*21,000	20,000	16,100	14,900	10,800	10,500	9,900	7,300	7,700	7,300	5,400	7,100	6,800	5,000		5000	
	Lower (std UC) – f. stabilizer & r. dozer down	*21,000	*21,000	*24,400	*24,400	18,400	18,000	18,000	12,000	13,500	12,000	8,000	7,000	5,400	7,400	6,500	5,000		5000
	Lower (std UC) – f. dozer & r. stabilizer up	*21,000	*21,000	20,000	16,700	14,300	10,800	10,900	9,500	7,300	8,000	7,000	5,400	7,400	6,500	5,000		5000	
	Lower (std UC) – f. dozer & r. stabilizer down	*21,000	*21,000	*24,400	*24,400	19,100	18,000	18,000	12,300	13,500	12,300	9,000	7,700	5,700	7,700	7,700		7700	
-10 ft	Lower (std UC) – 2 sets stabilizers up	*21,000	*21,000	20,300	16,600	14,800	10,900	10,800	9,800	7,400	8,000	7,300	5,500	7,400	6,700	5,100		5100	
	Lower (std UC) – 2 sets stabilizers down	*21,000	*21,000	*24,400	*24,400	23,700	18,500	18,500	15,000	13,500	13,500	10,800	8,000	7,700	7,700	7,700		7700	
	MH – stabilizers up – solid tires	*28,600	*28,600	21,500	16,500	16,500	11,500	10,800	10,800	7,700								8700	
	MH – stabilizers down – solid tires	*28,600	*28,600	*28,600	*21,100	*21,100	*21,100	*15,600	*15,600	*15,600								9700	
	Lower (std UC) – f. stabilizer & r. dozer up	*28,600	*28,600	20,400	16,200	15,100	10,900	10,600	10,000	7,300								8400	
	Lower (std UC) – f. stabilizer & r. dozer down	*28,600	*28,600	*28,600	*21,100	*21,100	18,500	*15,600	*15,600	12,000								9700	
-15 ft	Lower (std UC) – f. dozer & r. stabilizer up	*28,600	*28,600	20,400	16,800	14,500	10,900	11,000	9,600	7,300								8800	
	Lower (std UC) – f. dozer & r. stabilizer down	*28,600	*28,600	*28,600	*21,100	*21,100	19,200	*15,600	*15,600	12,400								9700	
	Lower (std UC) – 2 sets stabilizers up	*28,600	*28,600	20,600	16,700	15,000	11,100	10,900	9,900	7,400								8700	
	Lower (std UC) – 2 sets stabilizers down	*28,600	*28,600	*28,600	*21,100	*21,100	*21,100	*15,600	*15,600	15,000								9700	
	MH – stabilizers up – solid tires																	14,500	
	MH – stabilizers down – solid tires																	14,500	

9

\*Limited by hydraulic rather than tipping load.

Lift capacity ratings are based on ISO 10567:2007, they do not exceed 87% of hydraulic lifting capacity or 75% of tipping load. The load point is the center line of the bucket pivot mounting pin on the stick. The oscillating axle must be locked. Lifting capacities are based on the machine standing on a firm uniform supporting surface. For lifting capacity including bucket and/or quick coupler, the respective weight has to be subtracted from above values. The use of a work tool attachment point to handle/lift objects, could affect the machine lift performance.

Always refer to the appropriate Operation and Maintenance Manual for specific product information.

### Lift Capacities

All values are in kg, bucket cylinder and linkage installed, hydraulic cab riser, work tool: none, with counterweight (5200 kg), heavy lift on.

		Load point height			Load over front			Load over rear			Load over side			Load at maximum reach (sticknose/bucket pin)			
Undercarriage		Boom									Stick						
MH or Standard		3000 mm			4500 mm			6000 mm			7500 mm					mm	
Undercarriage configuration																	
7500 mm	MH – stabilizers up – solid tires																*3050
	MH – stabilizers down – solid tires																*3050
	Lower (std UC) – f. stabilizer & r. dozer up																*3050
	Lower (std UC) – f. stabilizer & r. dozer down																*3050
	Lower (std UC) – f. dozer & r. stabilizer up																*3050
6000 mm	MH – stabilizers up – solid tires																*3850
	MH – stabilizers down – solid tires																*3850
	Lower (std UC) – f. stabilizer & r. dozer up																*3850
	Lower (std UC) – f. stabilizer & r. dozer down																*3850
	Lower (std UC) – f. dozer & r. stabilizer up																*3850
4500 mm	MH – stabilizers up – solid tires																6500
	MH – stabilizers down – solid tires																6500
	Lower (std UC) – f. stabilizer & r. dozer up																4900
	Lower (std UC) – f. stabilizer & r. dozer down																4600
	Lower (std UC) – f. dozer & r. stabilizer up																4500
3000 mm	MH – stabilizers up – solid tires																9550
	MH – stabilizers down – solid tires																9550
	Lower (std UC) – f. stabilizer & r. dozer up																7000
	Lower (std UC) – f. stabilizer & r. dozer down																6250
	Lower (std UC) – f. dozer & r. stabilizer up																6250
1500 mm	MH – stabilizers up – solid tires																9000
	MH – stabilizers down – solid tires																9000
	Lower (std UC) – f. stabilizer & r. dozer up																8900
	Lower (std UC) – f. stabilizer & r. dozer down																8900
	Lower (std UC) – f. dozer & r. stabilizer up																8900
0 mm	MH – stabilizers up – solid tires																8700
	MH – stabilizers down – solid tires																8700
	Lower (std UC) – f. stabilizer & r. dozer up																8000
	Lower (std UC) – f. stabilizer & r. dozer down																8000
	Lower (std UC) – f. dozer & r. stabilizer up																8000
-1500 mm	MH – stabilizers up – solid tires	*9250	*9250	*9250	8600	8600	6150	5700	5700	4150	4200	4200	3100	*3500	*3500	2800	8100
	MH – stabilizers down – solid tires	*9250	*9250	*9250	*11 250	*11 250	*11 250	*8300	*8300	*8300	*6300	*6300	*6300	*3500	*3500	*3500	8100
	Lower (std UC) – f. stabilizer & r. dozer up	*9250	*9250	*9250	8550	7900	5850	5600	5250	3950	4100	3900	2950	*3500	*3500	2650	8100
	Lower (std UC) – f. stabilizer & r. dozer down	*9250	*9250	*9250	*11 250	*11 250	9650	*8300	*8300	6300	*6300	*6300	4600	*3500	*3500	3400	8100
	Lower (std UC) – f. dozer & r. stabilizer up	*9250	*9250	*9250	8800	7650	5850	5800	5050	3950	4250	3750	2950	*3500	*3500	2650	8100
-3000 mm	MH – stabilizers up – solid tires	*13 200	*13 200	*11 500	8650	8650	6200	5700	5700	4200	4200	3150	*3500	*3500	*3500	3300	7260
	MH – stabilizers down – solid tires	*13 200	*13 200	*13 200	*9750	*9750	*9750	*7250	*7250	*7250	*7250	*7250	4350	*4350	*4350	3150	7260
	Lower (std UC) – f. stabilizer & r. dozer up	*13 200	*13 200	*11 000	8600	7950	5900	5600	5300	4000	4000	3000	2150	*3500	*3500	1950	7260
	Lower (std UC) – f. stabilizer & r. dozer down	*13 200	*13 200	*13 200	*9750	*9750	9750	*7250	*7250	6300	6300	4000	3000	*3500	*3500	2700	7260
	Lower (std UC) – f. dozer & r. stabilizer up	*13 200	*13 200	*11 000	8900	7750	5900	5800	5100	4000	4000	3000	2150	*3500	*3500	1950	7260
-4500 mm	MH – stabilizers up – solid tires	*13 200	*13 200	*13 200	*9750	*9750	9750	*7250	*7250	6500	6500	4000	3000	*3500	*3500	2700	7260
	MH – stabilizers down – solid tires	*13 200	*13 200	*13 200	*9750	*9750	9750	*7250	*7250	6500	6500	4000	3000	*3500	*3500	2700	7260
	Lower (std UC) – f. stabilizer & r. dozer up	*13 200	*13 200	*11 000	8850	7950	6000	5750	5250	4050	4050	3000	2150	*3500	*3500	1950	7260
	Lower (std UC) – f. stabilizer & r. dozer down	*13 200	*13 200	*13 200	*9750	*9750	9750	*7250	*7250	6500	6500	4000	3000	*3500	*3500	2700	7260
	Lower (std UC) – f. dozer & r. stabilizer up	*13 200	*13 200	*11 000	8850	7950	6000	5750	5250	4050	4050	3000	2150	*3500	*3500	1950	7260

\*Limited by hydraulic rather than tipping load.

Lift capacity ratings are based on ISO 10567:2007, they do not exceed 87% of hydraulic lifting capacity or 75% of tipping load. The load point is the center line of the bucket pivot mounting pin on the stick. The oscillating axle must be locked. Lifting capacities are based on the machine standing on a firm uniform supporting surface. For lifting capacity including bucket and/or quick coupler, the respective weight has to be subtracted from above values. The use of a work tool attachment point to handle/lift objects, could affect the machine lift performance.

Always refer to the appropriate Operation and Maintenance Manual for specific product information.

# Lifting Capacities ● MH3024 (Grenoble Sourced)

# Material Handlers

## Lift Capacities

All values are in lb, bucket cylinder and linkage installed, hydraulic cab riser, work tool: none, with counterweight (11,470 lb), heavy lift on.

		Load point height			Load over front			Load over rear			Load over side			Load at maximum reach (sticknose/bucket pin)					
	Undercarriage configuration	10 ft			15 ft			20 ft			25 ft						ft		
25 ft	MH – stabilizers up – solid tires																*6900	*6900	*6900
	MH – stabilizers down – solid tires																*6900	*6900	*6900
	Lower (std UC) – f. stabilizer & r. dozer up																*6900	*6900	*6900
	Lower (std UC) – f. stabilizer & r. dozer down																*6900	*6900	*6900
	Lower (std UC) – f. dozer & r. stabilizer up																*6900	*6900	*6900
	Lower (std UC) – 2 sets stabilizers down																*6900	*6900	*6900
20 ft	MH – stabilizers up – solid tires																*6100	*6100	*6100
	MH – stabilizers down – solid tires																*6100	*6100	*6100
	Lower (std UC) – f. stabilizer & r. dozer up																*6100	*6100	*6100
	Lower (std UC) – f. stabilizer & r. dozer down																*6100	*6100	*6100
	Lower (std UC) – f. dozer & r. stabilizer up																*6100	*6100	*6100
	Lower (std UC) – 2 sets stabilizers down																*6100	*6100	*6100
15 ft	MH – stabilizers up – solid tires								14,000	14,000	10,600	9900	9900	7500			*5900	*5900	*5900
	MH – stabilizers down – solid tires								*14,300	*14,300	*14,300	*12,800	*12,800	*12,800			*5900	*5900	*5900
	Lower (std UC) – f. stabilizer & r. dozer up								13,800	13,100	10,200	9700	9200	7100			*5900	*5900	*5900
	Lower (std UC) – f. stabilizer & r. dozer down								*14,300	*14,300	*14,300	*12,800	*12,800	10,800			*5900	*5900	*5900
	Lower (std UC) – f. dozer & r. stabilizer up								14,200	12,700	10,200	10,000	8900	7100			*5900	*5900	*5900
	Lower (std UC) – 2 sets stabilizers down								*14,300	*14,300	*14,300	*12,800	*12,800	11,100			*5900	*5900	*5900
10 ft	MH – stabilizers up – solid tires				20,600	20,600	15,100	13,500	10,100	9700	9700	7200					*5900	*5900	5900
	MH – stabilizers down – solid tires				*21,200	*21,200	*16,500	*16,500	*16,000	*13,500	*13,500	*13,500					*5900	*5900	*5900
	Lower (std UC) – f. stabilizer & r. dozer up				20,500	19,100	14,500	12,200	12,500	9700	9400	9000	6900				*5900	*5900	5600
	Lower (std UC) – f. stabilizer & r. dozer down				*21,200	*21,200	*21,200	*16,000	*16,000	14,800	*13,500	*13,500	10,500				*5900	*5900	*5900
	Lower (std UC) – f. dozer & r. stabilizer up				21,100	18,500	14,500	13,700	12,100	9700	9800	8700	6900				*5900	*5900	5600
	Lower (std UC) – 2 sets stabilizers down				*21,200	*21,200	*21,200	*16,000	*16,000	15,200	*13,500	*13,500	10,800				*5900	*5900	*5900
5 ft	MH – stabilizers up – solid tires				19,400	19,400	14,000	12,900	12,900	9500	9400	9400	7000				*6100	*6100	5600
	MH – stabilizers down – solid tires				*24,600	*24,600	*24,600	*17,700	*17,700	*17,700	*14,200	*14,200	*14,200				*6100	*6100	*6100
	Lower (std UC) – f. stabilizer & r. dozer up				19,200	17,900	13,400	12,600	11,900	9100	9200	8700	6600				*6100	*6100	5400
	Lower (std UC) – f. dozer & r. stabilizer up				19,800	17,300	13,400	13,100	11,500	9100	9500	8400	6600				*6100	*6100	5400
	Lower (std UC) – f. dozer & r. stabilizer down				*24,600	*24,600	22,400	*17,700	*17,700	14,600	*14,200	*14,200	10,500				*6100	*6100	*6100
	Lower (std UC) – 2 sets stabilizers down				19,700	17,800	13,500	13,000	11,900	9200	9400	8600	6700				*6100	*6100	5400
0 ft	MH – stabilizers up – solid tires				18,700	18,700	13,400	12,500	12,500	9100	9100	6800					*6700	*6700	5700
	MH – stabilizers down – solid tires				*25,700	*25,700	*25,700	*18,500	*18,500	*18,500	*14,400	*14,400	*14,400				*6700	*6700	*6700
	Lower (std UC) – f. stabilizer & r. dozer up				18,500	17,200	12,800	12,200	11,500	8700	8900	8500	6400				*6700	*6700	5500
	Lower (std UC) – f. stabilizer & r. dozer down				*25,700	*25,700	21,000	*18,500	*18,500	13,700	*14,400	*14,400	10,000				*6700	*6700	*6700
	Lower (std UC) – f. dozer & r. stabilizer up				19,200	16,600	12,900	12,600	11,100	8700	9200	8200	6400				*6700	*6700	5500
	Lower (std UC) – 2 sets stabilizers down				*25,700	*25,700	21,700	*18,500	*18,500	14,100	*14,400	*14,400	10,300				*6700	*6700	*6700
-5 ft	MH – stabilizers up – solid tires	*21,000	*21,000	*21,000	18,500	18,500	13,200	12,300	12,300	9000	9100	9100	6700				*7700	*7700	6200
	MH – stabilizers down – solid tires	*21,000	*21,000	*21,000	*24,400	*24,400	*24,400	*18,000	*18,000	*18,000	*13,500	*13,500	*13,500				*7700	*7700	*7700
	Lower (std UC) – f. stabilizer & r. dozer up	*21,000	*21,000	*21,000	18,300	17,000	12,600	12,000	11,300	8500	8900	8400	6400				*7700	*7700	5900
	Lower (std UC) – f. stabilizer & r. dozer down	*21,000	*21,000	*24,400	*24,400	20,800	*18,000	*18,000	13,600	*13,500	*13,500	9000	7700				*7700	*7700	*7700
	Lower (std UC) – f. dozer & r. stabilizer up	*21,000	*21,000	*21,000	19,000	16,400	12,600	12,500	10,900	8500	9200	8100	6400				*7700	*7700	5900
	Lower (std UC) – 2 sets stabilizers down	*21,000	*21,000	*21,000	*24,400	*24,400	21,500	*18,000	*18,000	13,900	*13,500	*13,500	10,200				*7700	*7700	*7700
-10 ft	MH – stabilizers up – solid tires	*28,600	*28,600	*28,600	24,700	18,700	13,700	12,300	12,300	9000							*9700	*9700	7300
	MH – stabilizers down – solid tires	*28,600	*28,600	*28,600	*21,100	*21,100	*21,100	*15,600	*15,600	*15,600							*9700	*9700	*9700
	Lower (std UC) – f. stabilizer & r. dozer up	*28,600	*28,600	*28,600	23,600	18,100	12,700	12,100	11,400	8600							*9700	*9700	7000
	Lower (std UC) – f. stabilizer & r. dozer down	*28,600	*28,600	*28,600	*21,100	*21,100	20,900	*15,600	*15,600	13,600							*9700	*9700	*9700
	Lower (std UC) – f. dozer & r. stabilizer up	*28,600	*28,600	*28,600	19,100	16,600	12,700	12,500	11,000	8600							*9700	*9700	7000
	Lower (std UC) – 2 sets stabilizers down	*28,600	*28,600	*28,600	*21,100	*21,100	*21,100	*15,600	*15,600	14,000							*9700	*9700	*9700
-15 ft	MH – stabilizers up – solid tires				*28,600	*28,600	19,000	17,100	12,900	12,400	11,300	8700					*9700	*9700	7000
	MH – stabilizers down – solid tires				*28,600	*28,600	*21,100	*21,100	*21,100	*15,600	*15,600	*15,600					*9700	*9700	*9700
	Lower (std UC) – f. stabilizer & r. dozer up																		
	Lower (std UC) – f. stabilizer & r. dozer down																		
	Lower (std UC) – f. dozer & r. stabilizer up																		
	Lower (std UC) – 2 sets stabilizers down																		

\*Limited by hydraulic rather than tipping load.

Lift capacity ratings are based on ISO 10567:2007, they do not exceed 87% of hydraulic lifting capacity or 75% of tipping load. The load point is the center line of the bucket pivot mounting pin on the stick. The oscillating axle must be locked. Lifting capacities are based on the machine standing on a firm uniform supporting surface. For lifting capacity including bucket and/or quick coupler, the respective weight has to be subtracted from above values. The use of a work tool attachment point to handle/lift objects, could affect the machine lift performance.

Always refer to the appropriate Operation and Maintenance Manual for specific product information.

### Lift Capacities

All values are in kg, bucket cylinder and linkage installed, hydraulic cab riser, work tool: none, with counterweight (4100 kg), heavy lift on.

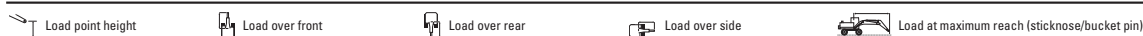

#### Undercarriage

#### Boom

#### Stick

MH or Standard

VA

2.5 m

Undercarriage configuration	3000 mm			4500 mm			6000 mm			7500 mm			mm	
7500 mm	MH – stabilizers up – solid tires MH – stabilizers down – solid tires Lower (std UC) – f. stabilizer & r. dozer up Lower (std UC) – f. stabilizer & r. dozer down Lower (std UC) – f. dozer & r. stabilizer up Lower (std UC) – f. dozer & r. stabilizer down Lower (std UC) – 2 sets stabilizers up Lower (std UC) – 2 sets stabilizers down												*3850 *3850	5870
6000 mm	MH – stabilizers up – solid tires MH – stabilizers down – solid tires Lower (std UC) – f. stabilizer & r. dozer up Lower (std UC) – f. stabilizer & r. dozer down Lower (std UC) – f. dozer & r. stabilizer up Lower (std UC) – f. dozer & r. stabilizer down Lower (std UC) – 2 sets stabilizers up Lower (std UC) – 2 sets stabilizers down						6000 *6750 6000 *6750 4450 *6750	6000 *6750 5900 *6750 6600 *6750	6000 *6750 5900 *6750 6600 *6750				*3350 *3350	7080
4500 mm	MH – stabilizers up – solid tires MH – stabilizers down – solid tires Lower (std UC) – f. stabilizer & r. dozer up Lower (std UC) – f. stabilizer & r. dozer down Lower (std UC) – f. dozer & r. stabilizer up Lower (std UC) – f. dozer & r. stabilizer down Lower (std UC) – 2 sets stabilizers up Lower (std UC) – 2 sets stabilizers down			*8750 *8750 *8750 *8750 *8750 *8750 *8750 *8750 *8750 *8750 *8750 *8750	*8750 *8750 *8750 *8750 *8750 *8750 *8750 *8750 *8750 *8750 *8750 *8750	6700 *7100 6400 *7100 5900 *7100 5200 *7100 4150 *7100 4300 *7100	5800 *7100 5400 *7100 5200 *7100 4100 *7100 6600 *7100 5350 *7100	4300 *5800 4100 *5800 4100 *5800 3750 *5800 4050 *5800 4050 *5800	4050 *5800 3750 *5800 3750 *5800 2850 *5800 4550 *5800 4550 *5800	3000 *5800 2850 *5800 4450 *5800 3600 *5800 3750 *5800 3750 *5800		*3150 *3150	7810	
3000 mm	MH – stabilizers up – solid tires MH – stabilizers down – solid tires Lower (std UC) – f. stabilizer & r. dozer up Lower (std UC) – f. stabilizer & r. dozer down Lower (std UC) – f. dozer & r. stabilizer up Lower (std UC) – f. dozer & r. stabilizer down Lower (std UC) – 2 sets stabilizers up Lower (std UC) – 2 sets stabilizers down			8550 *10500 8450 *10500 *10500 *10500 8700 *10500 *10500 *10500 8650 *10500 *10500 *10500	8550 *10500 7850 *10500 9550 *10500 7550 *10500 9900 *10500 7800 *10500 *10500 *10500	6100 *7550 5800 *7550 5450 *7550 5650 *7550 5900 *7550 5600 *7550 *7550 *7550	5550 *7550 5150 *7550 3850 *7550 4950 *7550 6300 *7550 3900 *7550 *7550 *7550	4050 *6000 3850 *6000 3850 *6000 4000 *6000 4450 *6000 3950 *6000 *6000 *6000	3950 *6000 3650 *6000 3500 *6000 4350 *6000 4750 *6000 3650 *6000 *6000 *6000	2900 *6000 2750 *6000 4350 *6000 3050 *6000 3100 *6000 3100 *6000 *3100 *3100		*3100 *3100	8190	
1500 mm	MH – stabilizers up – solid tires MH – stabilizers down – solid tires Lower (std UC) – f. stabilizer & r. dozer up Lower (std UC) – f. stabilizer & r. dozer down Lower (std UC) – f. dozer & r. stabilizer up Lower (std UC) – f. dozer & r. stabilizer down Lower (std UC) – 2 sets stabilizers up Lower (std UC) – 2 sets stabilizers down			7850 *11700 7850 *11700 *11700 *11700 7850 *11700 *11700 *11700 8150 *11700 *11700 *11700	7850 *11700 7300 *11700 8950 *11700 5300 *11700 9300 *11700 7000 *11700 *11700 *11700	5300 *8250 5150 *8250 4850 *8250 3300 *8250 5300 *8250 5250 *8250 *8250 *8250	5300 *8250 4850 *8250 5850 *8250 3800 *8250 3850 *8250 3400 *8250 *8250 *8250	3850 *6300 3650 *6300 3600 *6300 3750 *6300 3400 *6300 3400 *6300 *6300 *6300	3850 *6300 3550 *6300 2600 *6300 4250 *6300 2900 *6300 2500 *6300 *6300 *6300	2750 *6300 2600 *6300 3200 *6300 3050 *6300 3250 *6300 2900 *6300 *6300 *6300		*3250 *3250	8280	
0 mm	MH – stabilizers up – solid tires MH – stabilizers down – solid tires Lower (std UC) – f. stabilizer & r. dozer up Lower (std UC) – f. stabilizer & r. dozer down Lower (std UC) – f. dozer & r. stabilizer up Lower (std UC) – f. dozer & r. stabilizer down Lower (std UC) – 2 sets stabilizers up Lower (std UC) – 2 sets stabilizers down			7700 *11650 7700 *11650 *11650 *11650 7800 *11650 *11650 *11650 7900 *11650 *11650 *11650	7700 *11650 7050 *11650 8700 *11650 5100 *11650 9000 *11650 5100 *11650 *11650 *11650	5350 *8500 5100 *8500 4700 *8500 3300 *8500 5850 *8500 4500 *8500 *8500 *8500	5100 *8500 4700 *8500 5700 *8500 3450 *8500 5850 *8500 4500 *8500 *8500 *8500	3650 *6550 3750 *6550 3750 *6550 3450 *6550 3800 *6550 3300 *6550 *6550 *6550	3750 *6550 2700 *6550 4150 *6550 3450 *6550 3300 *6550 2550 *6550 *6550 *6550	2400 *6550 3400 *6550 3500 *6550 3100 *6550 3000 *6550 3000 *6550 *6550 *6550		*3500 *3500	8070	
-1500 mm	MH – stabilizers up – solid tires MH – stabilizers down – solid tires Lower (std UC) – f. stabilizer & r. dozer up Lower (std UC) – f. stabilizer & r. dozer down Lower (std UC) – f. dozer & r. stabilizer up Lower (std UC) – f. dozer & r. stabilizer down Lower (std UC) – 2 sets stabilizers up Lower (std UC) – 2 sets stabilizers down	*10000 *10000 *10000 *10000 *10000 *10000 *10000 *10000 *10000 *10000 *10000 *10000 *10000 *10000	9900 *10000 9400 *10000 *10000 *10000 9400 *10000 *10000 *10000 9550 *10000 *10000 *10000	7650 *10600 7550 *10600 7000 *10600 8850 *10600 5050 *10600 5100 *10600 *10600 *10600	5300 *7900 5050 *7900 4950 *7900 5600 *7900 4450 *7900 4600 *7900 *7900 *7900	5050 *7900 4650 *7900 5600 *7900 3400 *7900 5800 *7900 3500 *7900 *7900 *7900	3600 *6510 3400 *6510 3400 *6510 3800 *6510 3300 *6510 2600 *6510 *6510 *6510	3750 *6510 3650 *6510 3450 *6510 3300 *6510 2550 *6510 2600 *6510 *6510 *6510	2700 *6510 2550 *6510 4150 *6510 3750 *6510 4250 *6510 3400 *6510 *6510 *6510	3750 *6510 3600 *6510 4000 *6510 3300 *6510 3000 *6510 3400 *6510 *6510 *6510		*2650 *4000 *4000 *2650 *4000 *4000 *2650 *4000 *4000 *2650 *4000 *4000 *2650 *4000 *4000 *2650 *4000 *4000 *2650 *4000 *4000	7550	
-3000 mm	MH – stabilizers up – solid tires MH – stabilizers down – solid tires Lower (std UC) – f. stabilizer & r. dozer up Lower (std UC) – f. stabilizer & r. dozer down Lower (std UC) – f. dozer & r. stabilizer up Lower (std UC) – f. dozer & r. stabilizer down Lower (std UC) – 2 sets stabilizers up Lower (std UC) – 2 sets stabilizers down			7800 *8500 7800 *8500 *8500 *8500 7950 *8500 *8500 *8500 7900 *8500 *8500 *8500	7800 *8500 7100 *8500 8500 *8500 8800 *8500 5150 *8500 5200 *8500 *8500 *8500	5400 *6150 5150 *6150 5000 *6150 5200 *6150 4550 *6150 4700 *6150 *6150 *6150	5150 *6150 4700 *6150 5850 *6150 3500 *6150 5850 *6150 3500 *6150 *6150 *6150	3650 *6150 3450 *6150 5700 *6150 4450 *6150 5850 *6150 3500 *6150 *6150 *6150						

\*Limited by hydraulic rather than tipping load.

Lift capacity ratings are based on ISO 10567:2007, they do not exceed 87% of hydraulic lifting capacity or 75% of tipping load. The load point is the center line of the bucket pivot mounting pin on the stick. The oscillating axle must be locked. Lifting capacities are based on the machine standing on a firm uniform supporting surface and the Variable Boom Cylinder adjusted to the maximum length. For lifting capacity including bucket and/or quick coupler, the respective weight has to be subtracted from above values. The use of a work tool attachment point to handle/lift objects, could affect the machine lift performance.

Always refer to the appropriate Operation and Maintenance Manual for specific product information.

# Lifting Capacities ● MH3024 (Grenoble Sourced)

# Material Handlers

## Lift Capacities

All values are in lb, bucket cylinder and linkage installed, hydraulic cab riser, work tool: none, with counterweight (9040 lb), heavy lift on.



### Undercarriage

### Boom

### Stick

MH or Standard

VA

8'2"

Load point height	Undercarriage configuration	10 ft			15 ft			20 ft			25 ft			ft	
		Load over front	Load over rear	Load over side	Load over front	Load over rear	Load over side	Load over front	Load over rear	Load over side	Load at maximum reach (sticknose/bucket pin)	ft			
25 ft	MH – stabilizers up – solid tires														
	MH – stabilizers down – solid tires														
	Lower (std UC) – f. stabilizer & r. dozer up														
	Lower (std UC) – f. stabilizer & r. dozer down														
	Lower (std UC) – f. dozer & r. stabilizer up														
	Lower (std UC) – f. dozer & r. stabilizer down														
	Lower (std UC) – 2 sets stabilizers up														
20 ft	MH – stabilizers up – solid tires							12,900	12,900	9600					
	MH – stabilizers down – solid tires							*14,800	*14,800	*14,800					
	Lower (std UC) – f. stabilizer & r. dozer up							12,600	11,900	9200					
	Lower (std UC) – f. stabilizer & r. dozer down							*14,800	*14,800	14,100					
	Lower (std UC) – f. dozer & r. stabilizer up							13,000	11,500	9200					
	Lower (std UC) – f. dozer & r. stabilizer down							*14,800	*14,800	14,500					
	Lower (std UC) – 2 sets stabilizers up							13,000	11,900	9300					
15 ft	MH – stabilizers up – solid tires							*14,800	*14,800	*14,800					
	MH – stabilizers down – solid tires							*18,900	*18,900	14,400	12,500	9300	8700	8700	6400
	Lower (std UC) – f. stabilizer & r. dozer up							*18,900	18,300	13,800	12,300	11,600	8800	8500	8000
	Lower (std UC) – f. stabilizer & r. dozer down							*18,900	*18,900	*15,400	*15,400	*15,400	*10,700	*10,700	*10,700
	Lower (std UC) – f. dozer & r. stabilizer up							*18,900	17,700	13,800	12,700	11,200	8800	8800	7700
	Lower (std UC) – f. dozer & r. stabilizer down							*18,900	*18,900	*15,400	*15,400	14,200	*10,700	*10,700	9800
	Lower (std UC) – 2 sets stabilizers up							*18,900	18,200	14,000	12,600	11,600	8900	8700	8000
10 ft	MH – stabilizers up – solid tires							*18,900	*18,900	*15,400	*15,400	*10,700	*10,700	*10,700	*7000
	MH – stabilizers down – solid tires							18,400	18,400	13,200	12,000	9300	8500	8500	6200
	Lower (std UC) – f. stabilizer & r. dozer up							*22,700	*22,700	*22,700	*16,300	*16,300	*16,300	*13,000	*13,000
	Lower (std UC) – f. stabilizer & r. dozer down							18,200	16,900	12,600	11,700	11,100	8300	7900	5900
	Lower (std UC) – f. dozer & r. stabilizer up							*22,700	*22,700	20,600	*16,300	*16,300	13,200	*13,000	9400
	Lower (std UC) – f. dozer & r. stabilizer down							18,600	16,300	12,600	12,100	10,700	8300	8600	7600
	Lower (std UC) – 2 sets stabilizers up							*22,700	*22,700	21,300	*16,300	*16,300	13,600	*13,000	9600
5 ft	MH – stabilizers up – solid tires							*22,700	*22,700	*22,700	*16,300	*16,300	*13,000	*13,000	*13,000
	MH – stabilizers down – solid tires							17,200	17,200	12,100	11,400	11,400	8200	8300	6300
	Lower (std UC) – f. stabilizer & r. dozer up							*25,300	*25,300	*25,300	*17,800	*17,800	*13,600	*13,600	13,500
	Lower (std UC) – f. stabilizer & r. dozer down							16,900	15,700	11,500	11,100	10,500	7800	8000	7600
	Lower (std UC) – f. dozer & r. stabilizer up							*25,300	*25,300	19,300	*17,800	*17,800	12,600	*13,600	9100
	Lower (std UC) – f. dozer & r. stabilizer down							17,600	15,100	11,500	11,600	10,100	7800	8400	7300
	Lower (std UC) – 2 sets stabilizers up							*25,300	*25,300	20,000	*17,800	*17,800	13,000	*13,600	9400
0 ft	MH – stabilizers up – solid tires							17,400	15,600	11,600	11,500	10,400	7900	8300	7600
	MH – stabilizers down – solid tires							*25,300	*25,300	24,800	*17,800	*17,800	15,800	*13,600	11,200
	Lower (std UC) – f. stabilizer & r. dozer up							16,800	16,600	11,600	11,000	11,000	7900	8100	8100
	Lower (std UC) – f. stabilizer & r. dozer down							*25,300	*25,300	*25,300	*18,400	*18,400	*14,100	*14,100	13,300
	Lower (std UC) – f. dozer & r. stabilizer up							16,300	15,200	11,000	10,800	10,100	7400	7900	7400
	Lower (std UC) – f. dozer & r. stabilizer down							*25,300	*25,300	18,700	*18,400	*18,400	12,200	*14,100	8900
	Lower (std UC) – 2 sets stabilizers up							17,000	14,600	11,000	11,200	9700	7400	8200	7100
-5 ft	MH – stabilizers up – solid tires							*25,300	*25,300	19,400	*18,400	*18,400	12,600	*14,100	13,500
	MH – stabilizers down – solid tires							16,900	15,100	11,100	11,100	10,100	7500	8100	7400
	Lower (std UC) – f. stabilizer & r. dozer up							*22,800	*22,800	21,300	*23,000	*23,000	*17,100	*17,100	13,900
	Lower (std UC) – f. stabilizer & r. dozer down							*22,800	*22,800	20,200	16,200	15,100	10,900	10,600	7300
	Lower (std UC) – f. dozer & r. stabilizer up							*22,800	*22,800	*22,800	*23,000	*23,000	18,600	*17,100	12,100
	Lower (std UC) – f. dozer & r. stabilizer down							*22,800	*22,800	20,200	16,900	14,500	10,900	11,100	9600
	Lower (std UC) – 2 sets stabilizers up							*22,800	*22,800	*22,800	*23,000	*23,000	19,300	*17,100	12,500
-10 ft	MH – stabilizers up – solid tires							*22,800	*22,800	20,500	16,800	15,000	11,000	9900	7400
	MH – stabilizers down – solid tires							*22,800	*22,800	*22,800	*23,000	*23,000	*17,100	*17,100	15,200
	Lower (std UC) – f. stabilizer & r. dozer up							16,700	16,700	11,700	11,100	11,100	7900		
	Lower (std UC) – f. stabilizer & r. dozer down							*18,300	*18,300	*18,300	*13,000	*13,000	*13,000		
	Lower (std UC) – f. dozer & r. stabilizer up							16,500	15,300	11,100	10,800	10,200	7500		
	Lower (std UC) – f. dozer & r. stabilizer down							*18,300	*18,300	*18,300	*13,000	*13,000	12,300		
	Lower (std UC) – 2 sets stabilizers up							17,100	14,700	11,100	11,200	9800	7500		

\*Limited by hydraulic rather than tipping load.

Lift capacity ratings are based on ISO 10567:2007, they do not exceed 87% of hydraulic lifting capacity or 75% of tipping load. The load point is the center line of the bucket pivot mounting pin on the stick. The oscillating axle must be locked. Lifting capacities are based on the machine standing on a firm uniform supporting surface and the Variable Boom Cylinder adjusted to the maximum length. For lifting capacity including bucket and/or quick coupler, the respective weight has to be subtracted from above values. The use of a work tool attachment point to handle/lift objects, could affect the machine lift performance.

Always refer to the appropriate Operation and Maintenance Manual for specific product information.

### Lift Capacities

All values are in kg, bucket cylinder and linkage installed, hydraulic cab riser, work tool: none, with counterweight (5200 kg), heavy lift on.

Load point height

Load over front

Load over rear

Load over side

Load at maximum reach (sticknose/bucket pin)

#### Undercarriage

MH or Standard

#### Boom VA

#### Stick 2.5 m

Stick height	Undercarriage configuration	3000 mm			4500 mm			6000 mm			7500 mm			mm		
		Load over front	Load over rear	Load over side	Load over front	Load over rear	Load over side	Load over front	Load over rear	Load over side	Load over front	Load over rear	Load over side			
7500 mm	MH – stabilizers up – solid tires															
	MH – stabilizers down – solid tires															
	Lower (std UC) – f. stabilizer & r. dozer up															
	Lower (std UC) – f. stabilizer & r. dozer down															
	Lower (std UC) – f. dozer & r. stabilizer up															
	Lower (std UC) – f. dozer & r. stabilizer down															
	Lower (std UC) – 2 sets stabilizers up															
6000 mm	MH – stabilizers up – solid tires							6650	6650	5050						
	MH – stabilizers down – solid tires							*6750	*6750	*6750						
	Lower (std UC) – f. stabilizer & r. dozer up							6600	6200	4850						
	Lower (std UC) – f. stabilizer & r. dozer down							*6750	*6750	*6750						
	Lower (std UC) – f. dozer & r. stabilizer up							*6750	6050	4850						
	Lower (std UC) – f. dozer & r. stabilizer down							*6750	*6750	*6750						
	Lower (std UC) – 2 sets stabilizers up							*6750	6200	4900						
4500 mm	MH – stabilizers up – solid tires							*8750	*8750	7550	6500	6500	4900	4550	4550	
	MH – stabilizers down – solid tires							*8750	*8750	*8750	*7100	*7100	*7100	*5800	*5800	
	Lower (std UC) – f. stabilizer & r. dozer up							*8750	*8750	7250	6400	6050	4700	4500	4250	
	Lower (std UC) – f. stabilizer & r. dozer down							*8750	*8750	*8750	*7100	*7100	*7100	*5800	*5800	
	Lower (std UC) – f. dozer & r. stabilizer up							*8750	*8750	7250	6600	5850	4700	4650	4100	
	Lower (std UC) – f. dozer & r. stabilizer down							*8750	*8750	*8750	*7100	*7100	*7100	*5800	*5800	
	Lower (std UC) – 2 sets stabilizers up							*8750	*8750	7300	6600	6050	4750	4600	4250	
3000 mm	MH – stabilizers up – solid tires							*9550	*9550	6950	6250	6250	4650	4500	4500	
	MH – stabilizers down – solid tires							*10 500	*10 500	*10 500	*7550	*7550	*7550	*6000	*6000	
	Lower (std UC) – f. stabilizer & r. dozer up							9500	8800	6650	6150	5800	4450	4400	4150	
	Lower (std UC) – f. stabilizer & r. dozer down							*10 500	*10 500	*10 500	*7550	*7550	6850	*6000	*6000	
	Lower (std UC) – f. dozer & r. stabilizer up							9800	8550	6650	6350	5600	4450	4500	4000	
	Lower (std UC) – f. dozer & r. stabilizer down							*10 500	*10 500	*10 500	*7550	*7550	7050	*6000	*6000	
	Lower (std UC) – 2 sets stabilizers up							9750	8750	6750	6300	5750	4500	4150	3200	
1500 mm	MH – stabilizers up – solid tires							*10 500	*10 500	*10 500	*7550	*7550	*7550	*6000	*6000	
	MH – stabilizers down – solid tires							*11 700	*11 700	*11 700	*8250	*8250	*8250	4400	4350	
	Lower (std UC) – f. stabilizer & r. dozer up							9000	8000	6450	6000	6000	4400	4350	4350	
	Lower (std UC) – f. stabilizer & r. dozer down							*11 700	*11 700	*11 700	*8250	*8250	*8250	*6300	*6300	
	Lower (std UC) – f. dozer & r. stabilizer up							8900	8250	6150	5900	5550	4200	4250	4050	
	Lower (std UC) – f. dozer & r. stabilizer down							*11 700	*11 700	10 100	*8250	*8250	6600	*6300	4800	
	Lower (std UC) – 2 sets stabilizers up							9200	8000	6150	6100	5350	4200	4400	3900	
0 mm	MH – stabilizers up – solid tires							*11 700	*11 700	10 450	*8250	*8250	6800	*6300	4050	
	MH – stabilizers down – solid tires							9150	8200	6200	6050	5500	4250	4400	4000	
	Lower (std UC) – f. stabilizer & r. dozer up							*11 700	*11 700	*11 700	*8250	*8250	8150	*6300	*6300	
	Lower (std UC) – f. stabilizer & r. dozer down							8750	8750	6200	5800	5800	4250	4250	3150	
	Lower (std UC) – f. dozer & r. stabilizer up							*11 650	*11 650	*11 650	*8500	*8500	*8500	*6550	*6550	
	Lower (std UC) – f. dozer & r. stabilizer down							8850	8000	5900	5700	5350	4050	4200	3950	
	Lower (std UC) – 2 sets stabilizers up							*11 650	*11 650	9800	*8500	*8500	6400	*6550	4700	
-1500 mm	MH – stabilizers up – solid tires							8950	7750	5900	5900	5150	4050	4350	3800	
	MH – stabilizers down – solid tires							*11 650	*11 650	10 150	*8500	*8500	6600	*6550	4800	
	Lower (std UC) – f. stabilizer & r. dozer up							8900	7950	6000	5850	5350	4100	4300	3950	
	Lower (std UC) – f. stabilizer & r. dozer down							*11 650	*11 650	*11 650	*8500	*8500	7950	*6550	5050	
	Lower (std UC) – f. dozer & r. stabilizer up							*10 000	*10 000	*10 000	*10 000	*10 000	*10 000	*10 000	*10 000	*10 000
	Lower (std UC) – f. dozer & r. stabilizer down							8700	8700	6150	5750	5750	4200	4250	3150	
	Lower (std UC) – 2 sets stabilizers up							*10 000	*10 000	*10 000	*10 000	*10 000	*7900	*7900	*5150	*5150
-3000 mm	MH – stabilizers up – solid tires							8600	8500	6250	5800	5800	4250	4250	3150	
	MH – stabilizers down – solid tires							*8500	*8500	*8500	*6150	*6150	*6150	*6150	*6150	
	Lower (std UC) – f. stabilizer & r. dozer up							*8500	8050	6000	5700	5400	4050	4050	4050	
	Lower (std UC) – f. stabilizer & r. dozer down							*8500	*8500	*8500	*6150	*6150	*6150	*6150	*6150	
	Lower (std UC) – f. dozer & r. stabilizer up							*8500	7800	6000	5900	5200	4050	4050	4050	
	Lower (std UC) – f. dozer & r. stabilizer down							*8500	*8500	*8500	*6150	*6150	*6150	*6150	*6150	
	Lower (std UC) – 2 sets stabilizers up							*8500	8050	6050	5900	5350	4100	4050	4100	

\*Limited by hydraulic rather than tipping load.

Lift capacity ratings are based on ISO 10567:2007, they do not exceed 87% of hydraulic lifting capacity or 75% of tipping load. The load point is the center line of the bucket pivot mounting pin on the stick. The oscillating axle must be locked. Lifting capacities are based on the machine standing on a firm uniform supporting surface and the Variable Boom Cylinder adjusted to the maximum length. For lifting capacity including bucket and/or quick coupler, the respective weight has to be subtracted from above values. The use of a work tool attachment point to handle/lift objects, could affect the machine lift performance.

Always refer to the appropriate Operation and Maintenance Manual for specific product information.

# Lifting Capacities ● MH3024 (Grenoble Sourced)

# Material Handlers

## Lift Capacities

All values are in lb, bucket cylinder and linkage installed, hydraulic cab riser, work tool: none, with counterweight (11,470 lb), heavy lift on.



### Undercarriage

### Boom

### Stick

MH or Standard

VA

8'2"

Stick ft	Undercarriage configuration	10 ft			15 ft			20 ft			25 ft			ft			
		Load over front	Load over rear	Load over side	Load over front	Load over rear	Load over side	Load over front	Load over rear	Load over side	Load over front	Load over rear	Load over side				
25 ft	MH – stabilizers up – solid tires														*8600	*8600	*8600
	MH – stabilizers down – solid tires														*8600	*8600	*8600
	Lower (std UC) – f. stabilizer & r. dozer up														*8600	*8600	*8600
	Lower (std UC) – f. stabilizer & r. dozer down														*8600	*8600	*8600
	Lower (std UC) – f. dozer & r. stabilizer up														*8600	*8600	*8600
	Lower (std UC) – f. dozer & r. stabilizer down														*8600	*8600	*8600
	Lower (std UC) – 2 sets stabilizers up														*8600	*8600	*8600
20 ft	MH – stabilizers up – solid tires							14,300	14,300	10,900					*7400	*7400	*7400
	MH – stabilizers down – solid tires							*14,800	*14,800	*14,800					*7400	*7400	*7400
	Lower (std UC) – f. stabilizer & r. dozer up							14,200	13,400	10,400					*7400	*7400	*7400
	Lower (std UC) – f. stabilizer & r. dozer down							*14,800	*14,800	*14,800					*7400	*7400	*7400
	Lower (std UC) – f. dozer & r. stabilizer up							14,600	13,000	10,400					*7400	*7400	*7400
	Lower (std UC) – f. dozer & r. stabilizer down							*14,800	*14,800	*14,800					*7400	*7400	*7400
	Lower (std UC) – 2 sets stabilizers up							14,500	13,300	10,500					*7400	*7400	*7400
15 ft	MH – stabilizers up – solid tires														*7400	*7400	*7400
	MH – stabilizers down – solid tires														*7400	*7400	*7400
	Lower (std UC) – f. stabilizer & r. dozer up														*7400	*7400	*7400
	Lower (std UC) – f. stabilizer & r. dozer down														*7400	*7400	*7400
	Lower (std UC) – f. dozer & r. stabilizer up														*7400	*7400	*7400
	Lower (std UC) – f. dozer & r. stabilizer down														*7400	*7400	*7400
	Lower (std UC) – 2 sets stabilizers up														*7400	*7400	*7400
10 ft	MH – stabilizers up – solid tires														*7000	*7000	*7000
	MH – stabilizers down – solid tires														*7000	*7000	*7000
	Lower (std UC) – f. stabilizer & r. dozer up														*7000	*7000	*7000
	Lower (std UC) – f. stabilizer & r. dozer down														*7000	*7000	*7000
	Lower (std UC) – f. dozer & r. stabilizer up														*7000	*7000	*7000
	Lower (std UC) – f. dozer & r. stabilizer down														*7000	*7000	*7000
	Lower (std UC) – 2 sets stabilizers up														*7000	*7000	*7000
5 ft	MH – stabilizers up – solid tires														*6900	*6900	*6900
	MH – stabilizers down – solid tires														*6900	*6900	*6900
	Lower (std UC) – f. stabilizer & r. dozer up														*6900	*6900	*6900
	Lower (std UC) – f. stabilizer & r. dozer down														*6900	*6900	*6900
	Lower (std UC) – f. dozer & r. stabilizer up														*6900	*6900	*6900
	Lower (std UC) – f. dozer & r. stabilizer down														*6900	*6900	*6900
	Lower (std UC) – 2 sets stabilizers up														*6900	*6900	*6900
0 ft	MH – stabilizers up – solid tires														*7700	*7700	*7700
	MH – stabilizers down – solid tires														*7700	*7700	*7700
	Lower (std UC) – f. stabilizer & r. dozer up														*7700	*7700	*7700
	Lower (std UC) – f. stabilizer & r. dozer down														*7700	*7700	*7700
	Lower (std UC) – f. dozer & r. stabilizer up														*7700	*7700	*7700
	Lower (std UC) – f. dozer & r. stabilizer down														*7700	*7700	*7700
	Lower (std UC) – 2 sets stabilizers up														*7700	*7700	*7700
-5 ft	MH – stabilizers up – solid tires														*8900	*8900	*8900
	MH – stabilizers down – solid tires														*8900	*8900	*8900
	Lower (std UC) – f. stabilizer & r. dozer up														*8900	*8900	*8900
	Lower (std UC) – f. stabilizer & r. dozer down														*8900	*8900	*8900
	Lower (std UC) – f. dozer & r. stabilizer up														*8900	*8900	*8900
	Lower (std UC) – f. dozer & r. stabilizer down														*8900	*8900	*8900
	Lower (std UC) – 2 sets stabilizers up														*8900	*8900	*8900
-10 ft	MH – stabilizers up – solid tires														*8900	*8900	*8900
	MH – stabilizers down – solid tires														*8900	*8900	*8900
	Lower (std UC) – f. stabilizer & r. dozer up														*8900	*8900	*8900
	Lower (std UC) – f. stabilizer & r. dozer down														*8900	*8900	*8900
	Lower (std UC) – f. dozer & r. stabilizer up														*8900	*8900	*8900
	Lower (std UC) – f. dozer & r. stabilizer down														*8900	*8900	*8900
	Lower (std UC) – 2 sets stabilizers up														*8900	*8900	*8900

\*Limited by hydraulic rather than tipping load.

Lift capacity ratings are based on ISO 10567:2007, they do not exceed 87% of hydraulic lifting capacity or 75% of tipping load. The load point is the center line of the bucket pivot mounting pin on the stick. The oscillating axle must be locked. Lifting capacities are based on the machine standing on a firm uniform supporting surface and the Variable Boom Cylinder adjusted to the maximum length. For lifting capacity including bucket and/or quick coupler, the respective weight has to be subtracted from above values. The use of a work tool attachment point to handle/lift objects, could affect the machine lift performance.

Always refer to the appropriate Operation and Maintenance Manual for specific product information.



### Lift Capacities

All values are in kg, bucket cylinder and linkage installed, hydraulic cab riser, work tool: none, with counterweight (4100 kg), heavy lift on.



#### Undercarriage

#### Boom

#### Stick

MH or Standard

VA

2.9 m

Stick height	Undercarriage configuration	3000 mm			4500 mm			6000 mm			7500 mm			Stick			mm
		Load over front	Load over rear	Load over side	Load over front	Load over rear	Load over side	Load over front	Load over rear	Load over side	Load over front	Load over rear	Load over side	Load over front	Load over rear	Load over side	
7500 mm	MH – stabilizers up – solid tires							*5100	*5100	4500				*3100	*3100	*3100	6410
	MH – stabilizers down – solid tires							*5100	*5100	*5100				*3100	*3100	*3100	
	Lower (std UC) – f. stabilizer & r. dozer up							*5100	*5100	4300				*3100	*3100	*3100	
	Lower (std UC) – f. stabilizer & r. dozer down							*5100	*5100	*5100				*3100	*3100	*3100	
	Lower (std UC) – f. dozer & r. stabilizer up							*5100	*5100	4300				*3100	*3100	*3100	
	Lower (std UC) – f. dozer & r. stabilizer down							*5100	*5100	*5100				*3100	*3100	*3100	
	Lower (std UC) – 2 sets stabilizers up							*5100	*5100	4350				*3100	*3100	*3100	
6000 mm	MH – stabilizers up – solid tires							*6300	*6300	4500	*3150	*3150	3000	*2750	*2750	*2750	7540
	MH – stabilizers down – solid tires							*6300	*6300	4300	*3150	*3150	2850	*2750	*2750	*2750	
	Lower (std UC) – f. stabilizer & r. dozer up							*6300	*6300	4300	*3150	*3150	2850	*2750	*2750	*2750	
	Lower (std UC) – f. stabilizer & r. dozer down							*6300	*6300	4300	*3150	*3150	2850	*2750	*2750	*2750	
	Lower (std UC) – f. dozer & r. stabilizer up							*6300	*6300	4350	*3150	*3150	2900	*2750	*2750	*2750	
	Lower (std UC) – f. dozer & r. stabilizer down							*6300	*6300	4350	*3150	*3150	2900	*2750	*2750	*2750	
	Lower (std UC) – 2 sets stabilizers up							*6300	*6300	4350	*3150	*3150	2900	*2750	*2750	*2750	
4500 mm	MH – stabilizers up – solid tires				*7850	*7850	6800	5850	5850	4350	4100	4100	3000	*2600	*2600	2500	8230
	MH – stabilizers down – solid tires				*7850	*7850	*6800	*6800	*6800	*5600	*5600	*5600	*2600	*2600	*2600		
	Lower (std UC) – f. stabilizer & r. dozer up				*7850	*7850	6550	5450	5450	4150	4000	3800	2850	*2600	*2600	2400	
	Lower (std UC) – f. stabilizer & r. dozer down				*7850	*7850	*6800	*6800	*6800	6450	*5600	*5600	4500	*2600	*2600	*2600	
	Lower (std UC) – f. dozer & r. stabilizer up				*7850	*7850	6550	5950	5250	4150	4150	3850	2850	*2600	*2600	2400	
	Lower (std UC) – f. dozer & r. stabilizer down				*7850	*7850	*6800	*6800	*6800	6650	*5600	*5600	4600	*2600	*2600	*2600	
	Lower (std UC) – 2 sets stabilizers up				*7850	*7850	6600	5900	5400	4200	4100	3750	2900	*2600	*2600	2400	
3000 mm	MH – stabilizers up – solid tires				*8650	*8650	7200	5600	5600	4100	3950	3950	2900	*2600	*2600	2300	8590
	MH – stabilizers down – solid tires				*10000	*10000	*10000	*7300	*7300	*7300	*5800	*5800	*5800	*2600	*2600	*2600	
	Lower (std UC) – f. stabilizer & r. dozer up				8550	7950	5900	5450	5150	3900	3850	3850	2750	*2600	*2600	2150	
	Lower (std UC) – f. stabilizer & r. dozer down				*10000	*10000	9700	*7300	*7300	6150	*5800	*5800	4350	*2600	*2600	*2600	
	Lower (std UC) – f. dozer & r. stabilizer up				8850	7650	5900	5650	4950	3900	4000	3500	2750	*2600	*2600	2150	
	Lower (std UC) – f. dozer & r. stabilizer down				*10000	*10000	*10000	*7300	*7300	6350	*5800	*5800	4500	*2600	*2600	*2600	
	Lower (std UC) – 2 sets stabilizers up				8800	7900	6000	5650	5150	3950	4000	3650	2800	*2600	*2600	2200	
1500 mm	MH – stabilizers up – solid tires				*10000	*10000	*10000	*7300	*7300	*7300	*5900	*5900	*5900	*2600	*2600	*2600	8670
	MH – stabilizers down – solid tires				8050	8050	5650	5300	5300	3800	3850	3850	2750	*2650	*2650	2200	
	Lower (std UC) – f. stabilizer & r. dozer up				*11400	*11400	*11400	*7950	*7950	*7950	*6100	*6100	*6100	*2650	*2650	*2650	
	Lower (std UC) – f. stabilizer & r. dozer down				7900	7350	5350	5200	4900	3600	3700	3500	2600	*2650	*2650	2050	
	Lower (std UC) – f. dozer & r. stabilizer up				*11400	*11400	9050	*7950	*7950	5850	*6100	*6100	4200	*2650	*2650	*2650	
	Lower (std UC) – f. dozer & r. stabilizer down				8200	7050	5350	5400	4700	3600	3850	3400	2600	*2650	*2650	2050	
	Lower (std UC) – 2 sets stabilizers up				*11400	*11400	9350	*7950	*7950	6050	*6100	*6100	4350	*2650	*2650	*2650	
0 mm	MH – stabilizers up – solid tires				7700	7700	5350	5100	5100	3600	3700	3700	2650	*2850	*2850	2250	8470
	MH – stabilizers down – solid tires				*11750	*11750	*11750	*8500	*8500	*8500	*6450	*6450	6150	*2850	*2850	*2850	
	Lower (std UC) – f. stabilizer & r. dozer up				7800	7000	5050	4950	4650	3400	3600	3400	2500	*2850	*2850	2100	
	Lower (std UC) – f. stabilizer & r. dozer down				*11750	*11750	8700	*8500	*8500	5650	*6450	*6450	4100	*2850	*2850	*2850	
	Lower (std UC) – f. dozer & r. stabilizer up				7850	6750	5050	5150	4500	3400	3750	3250	2500	*2850	*2850	2100	
	Lower (std UC) – f. dozer & r. stabilizer down				*11750	*11750	9000	*8500	*8500	5850	*6450	*6450	4200	*2850	*2850	*2850	
	Lower (std UC) – 2 sets stabilizers up				7800	7000	5100	5150	4650	3450	3750	3400	2500	*2850	*2850	2150	
-1500 mm	MH – stabilizers up – solid tires	*9450	*9450	*9450	7600	7600	5250	5000	5000	3550	3700	3700	2600	*3250	*3250	2450	7980
	MH – stabilizers down – solid tires	*9450	*9450	*9450	*10950	*10950	*10950	*8100	*8100	*6000	*6000	*6000	*6000	*3250	*3250	*3250	
	Lower (std UC) – f. stabilizer & r. dozer up	*9450	*9450	9250	7500	6900	4950	4900	4600	3350	3550	3400	2450	*3250	3150	2300	
	Lower (std UC) – f. stabilizer & r. dozer down	*9450	*9450	*9450	*10950	*10950	8600	*8100	*8100	5550	*6000	*6000	4050	*3250	*3250	*3250	
	Lower (std UC) – f. dozer & r. stabilizer up	*9450	*9450	9250	7750	6650	4950	5050	4400	3350	3700	3250	2450	*3250	3000	2300	
	Lower (std UC) – f. dozer & r. stabilizer down	*9450	*9450	*9450	*10950	*10950	8900	*8100	*8100	5750	*6000	*6000	4200	*3250	*3250	*3250	
	Lower (std UC) – 2 sets stabilizers up	*9450	*9450	9350	7700	6900	5050	5050	4550	3400	3700	3350	2500	*3250	3100	2300	
-3000 mm	MH – stabilizers up – solid tires				7650	7650	5300	5050	5050	3550							6750
	MH – stabilizers down – solid tires				*9150	*9150	*9150	*6750	*6750	*6750							
	Lower (std UC) – f. stabilizer & r. dozer up				7550	7000	5050	4900	4600	3350							
	Lower (std UC) – f. stabilizer & r. dozer down				*9150	*9150	8650	*6750	*6750	5600							
	Lower (std UC) – f. dozer & r. stabilizer up				7850	6700	5050	5100	4450	3350							
	Lower (std UC) – f. dozer & r. stabilizer down				*9150	*9150	8950	*6750	*6750	5750							
	Lower (std UC) – 2 sets stabilizers up				7800	6950	5100	5050	4600	3400							

\*Limited by hydraulic rather than tipping load.

Lift capacity ratings are based on ISO 10567:2007, they do not exceed 87% of hydraulic lifting capacity or 75% of tipping load. The load point is the center line of the bucket pivot mounting pin on the stick. The oscillating axle must be locked. Lifting capacities are based on the machine standing on a firm uniform supporting surface and the Variable Boom Cylinder adjusted to the maximum length. For lifting capacity including bucket and/or quick coupler, the respective weight has to be subtracted from above values. The use of a work tool attachment point to handle/lift objects, could affect the machine lift performance.

Always refer to the appropriate Operation and Maintenance Manual for specific product information.

# Lifting Capacities ● MH3024 (Grenoble Sourced)

# Material Handlers

## Lift Capacities

All values are in lb, bucket cylinder and linkage installed, hydraulic cab riser, work tool: none, with counterweight (9040 lb), heavy lift on.

		Load point height			Load over front			Load over rear			Load over side			Load at maximum reach (sticknose/bucket pin)							
		10 ft			15 ft			20 ft			25 ft			Stick 9'6"			ft				
		Undercarriage configuration																			
30 ft	MH – stabilizers up – solid tires																	*9500	*9500	*9500	
	MH – stabilizers down – solid tires																		*9500	*9500	*9500
	Lower (std UC) – f. stabilizer & r. dozer up																		*9500	*9500	*9500
	Lower (std UC) – f. stabilizer & r. dozer down																		*9500	*9500	*9500
	Lower (std UC) – f. dozer & r. stabilizer up																		*9500	*9500	*9500
	Lower (std UC) – f. dozer & r. stabilizer down																		*9500	*9500	*9500
25 ft	MH – stabilizers up – solid tires																		*7000	*7000	*7000
	MH – stabilizers down – solid tires																		*7000	*7000	*7000
	Lower (std UC) – f. stabilizer & r. dozer up																		*7000	*7000	*7000
	Lower (std UC) – f. stabilizer & r. dozer down																		*7000	*7000	*7000
	Lower (std UC) – f. dozer & r. stabilizer up																		*7000	*7000	*7000
	Lower (std UC) – f. dozer & r. stabilizer down																		*7000	*7000	*7000
20 ft	MH – stabilizers up – solid tires																		*13,000	*13,000	*13,000
	MH – stabilizers down – solid tires																		*13,000	*13,000	*13,000
	Lower (std UC) – f. stabilizer & r. dozer up																		*13,000	*13,000	*13,000
	Lower (std UC) – f. stabilizer & r. dozer down																		*13,000	*13,000	*13,000
	Lower (std UC) – f. dozer & r. stabilizer up																		*13,000	*13,000	*13,000
	Lower (std UC) – f. dozer & r. stabilizer down																		*13,000	*13,000	*13,000
15 ft	MH – stabilizers up – solid tires																		*17,000	*17,000	*17,000
	MH – stabilizers down – solid tires																		*17,000	*17,000	*17,000
	Lower (std UC) – f. stabilizer & r. dozer up																		*17,000	*17,000	*17,000
	Lower (std UC) – f. stabilizer & r. dozer down																		*17,000	*17,000	*17,000
	Lower (std UC) – f. dozer & r. stabilizer up																		*17,000	*17,000	*17,000
	Lower (std UC) – f. dozer & r. stabilizer down																		*17,000	*17,000	*17,000
10 ft	MH – stabilizers up – solid tires																		*18,700	*18,700	*18,700
	MH – stabilizers down – solid tires																		*21,500	*21,500	*21,500
	Lower (std UC) – f. stabilizer & r. dozer up																		*18,400	*18,400	*18,400
	Lower (std UC) – f. stabilizer & r. dozer down																		*19,100	*19,100	*19,100
	Lower (std UC) – f. dozer & r. stabilizer up																		*21,500	*21,500	*21,500
	Lower (std UC) – f. dozer & r. stabilizer down																		*19,000	*19,100	*19,100
5 ft	MH – stabilizers up – solid tires																		*17,300	*17,300	*17,300
	MH – stabilizers down – solid tires																		*24,700	*24,700	*24,700
	Lower (std UC) – f. stabilizer & r. dozer up																		*17,100	*15,800	*11,600
	Lower (std UC) – f. stabilizer & r. dozer down																		*24,700	*24,700	*24,700
	Lower (std UC) – f. dozer & r. stabilizer up																		*17,700	*15,200	*11,600
	Lower (std UC) – f. dozer & r. stabilizer down																		*24,700	*24,700	*24,700
0 ft	MH – stabilizers up – solid tires																		*16,600	*16,600	*11,500
	MH – stabilizers down – solid tires																		*25,400	*25,400	*25,400
	Lower (std UC) – f. stabilizer & r. dozer up																		*16,300	*15,100	*10,900
	Lower (std UC) – f. stabilizer & r. dozer down																		*25,400	*25,400	*25,400
	Lower (std UC) – f. dozer & r. stabilizer up																		*16,900	*14,500	*10,900
	Lower (std UC) – f. dozer & r. stabilizer down																		*25,400	*25,400	*25,400
-5 ft	MH – stabilizers up – solid tires																		*21,500	*21,500	*21,500
	MH – stabilizers down – solid tires																		*21,500	*21,500	*21,500
	Lower (std UC) – f. stabilizer & r. dozer up																		*21,500	*21,500	*21,500
	Lower (std UC) – f. stabilizer & r. dozer down																		*21,500	*21,500	*21,500
	Lower (std UC) – f. dozer & r. stabilizer up																		*21,500	*21,500	*21,500
	Lower (std UC) – f. dozer & r. stabilizer down																		*21,500	*21,500	*21,500
-10 ft	MH – stabilizers up – solid tires																		*16,500	*16,500	*11,400
	MH – stabilizers down – solid tires																		*19,700	*19,700	*19,700
	Lower (std UC) – f. stabilizer & r. dozer up																		*16,200	*15,000	*10,800
	Lower (std UC) – f. stabilizer & r. dozer down																		*19,700	*19,700	*19,700
	Lower (std UC) – f. dozer & r. stabilizer up																		*16,900	*14,500	*10,800
	Lower (std UC) – f. dozer & r. stabilizer down																		*19,700	*19,700	*19,700



















\*Limited by hydraulic rather than tipping load.

Lift capacity ratings are based on ISO 10567:2007, they do not exceed 87% of hydraulic lifting capacity or 75% of tipping load. The load point is the center line of the bucket pivot mounting pin on the stick. The oscillating axle must be locked. Lifting capacities are based on the machine standing on a firm uniform supporting surface and the Variable Boom Cylinder adjusted to the maximum length. For lifting capacity including bucket and/or quick coupler, the respective weight has to be subtracted from above values. The use of a work tool attachment point to handle/lift objects, could affect the machine lift performance.

Always refer to the appropriate Operation and Maintenance Manual for specific product information.

**Lift Capacities**

All values are in kg, bucket cylinder and linkage installed, hydraulic cab riser, work tool: none, with counterweight (5200 kg), heavy lift on.

 Load point height  Load over front  Load over rear  Load over side  Load at maximum reach (sticknose/bucket pin)	Undercarriage configuration	3000 mm			4500 mm			6000 mm			7500 mm			mm		
																
9000 mm	MH – stabilizers up – solid tires				*4200	*4200	*4200							*4150	*4150	*4150
	MH – stabilizers down – solid tires				*4200	*4200	*4200							*4150	*4150	*4150
	Lower (std UC) – f. dozer & r. stabilizer & r. dozer up				*4200	*4200	*4200							*4150	*4150	*4150
	Lower (std UC) – f. stabilizer & r. dozer down				*4200	*4200	*4200							*4150	*4150	*4150
	Lower (std UC) – f. dozer & r. stabilizer up				*4200	*4200	*4200							*4150	*4150	*4150
	Lower (std UC) – f. dozer & r. stabilizer down				*4200	*4200	*4200							*4150	*4150	*4150
	Lower (std UC) – 2 sets stabilizers up				*4200	*4200	*4200							*4150	*4150	*4150
7500 mm	MH – stabilizers up – solid tires							*5100	*5100	5100				*3100	*3100	*3100
	MH – stabilizers down – solid tires							*5100	*5100	*5100				*3100	*3100	*3100
	Lower (std UC) – f. stabilizer & r. dozer up							*5100	*5100	4900				*3100	*3100	*3100
	Lower (std UC) – f. dozer & r. stabilizer up							*5100	*5100	*5100				*3100	*3100	*3100
	Lower (std UC) – f. dozer & r. stabilizer down							*5100	*5100	4900				*3100	*3100	*3100
	Lower (std UC) – 2 sets stabilizers up							*5100	*5100	*5100				*3100	*3100	*3100
	Lower (std UC) – 2 sets stabilizers down							*5100	*5100	4950				*3100	*3100	*3100
6000 mm	MH – stabilizers up – solid tires				*6300	*6300	6300	6300	6300	6100	*3150	*3150	*3150	*2750	*2750	*2750
	MH – stabilizers down – solid tires				*6300	*6300	6300	6300	6300	6100	*3150	*3150	*3150	*2750	*2750	*2750
	Lower (std UC) – f. stabilizer & r. dozer up				*6300	*6300	6300	6300	6300	6100	*3150	*3150	*3150	*2750	*2750	*2750
	Lower (std UC) – f. dozer & r. stabilizer up				*6300	*6300	6300	6300	6300	6100	*3150	*3150	*3150	*2750	*2750	*2750
	Lower (std UC) – f. dozer & r. stabilizer down				*6300	*6300	6300	6300	6300	6100	*3150	*3150	*3150	*2750	*2750	*2750
	Lower (std UC) – 2 sets stabilizers up				*6300	*6300	6300	6300	6300	6100	*3150	*3150	*3150	*2750	*2750	*2750
	Lower (std UC) – 2 sets stabilizers down				*6300	*6300	6300	6300	6300	6100	*3150	*3150	*3150	*2750	*2750	*2750
4500 mm	MH – stabilizers up – solid tires				*7850	*7850	7850	6550	6550	4950	4600	4600	3450	*2600	*2600	*2600
	MH – stabilizers down – solid tires				*7850	*7850	7850	6550	6550	4950	4600	4600	3450	*2600	*2600	*2600
	Lower (std UC) – f. stabilizer & r. dozer up				*7850	*7850	7850	6550	6550	4950	4600	4600	3450	*2600	*2600	*2600
	Lower (std UC) – f. dozer & r. stabilizer up				*7850	*7850	7850	6550	6550	4950	4600	4600	3450	*2600	*2600	*2600
	Lower (std UC) – f. dozer & r. stabilizer down				*7850	*7850	7850	6550	6550	4950	4600	4600	3450	*2600	*2600	*2600
	Lower (std UC) – 2 sets stabilizers up				*7850	*7850	7850	6550	6550	4950	4600	4600	3450	*2600	*2600	*2600
	Lower (std UC) – 2 sets stabilizers down				*7850	*7850	7850	6550	6550	4950	4600	4600	3450	*2600	*2600	*2600
3000 mm	MH – stabilizers up – solid tires				9650	9650	7050	6250	6250	4650	4500	4500	3350	*2600	*2600	*2600
	MH – stabilizers down – solid tires				*10 000	*10 000	*10 000	*7300	*7300	*7300	*5800	*5800	*5800	*2600	*2600	*2600
	Lower (std UC) – f. stabilizer & r. dozer up				9600	8900	6750	6200	5800	4450	4400	4150	3200	*2600	*2600	2550
	Lower (std UC) – f. dozer & r. stabilizer up				9600	8650	6750	6400	6550	4450	4550	4000	3200	*2600	*2600	2550
	Lower (std UC) – f. dozer & r. stabilizer down				*10 000	*10 000	*10 000	*7300	*7300	7100	*5800	*5800	5050	*2600	*2600	*2600
	Lower (std UC) – 2 sets stabilizers up				9850	8900	6850	6350	5800	4500	4500	4150	3250	*2600	*2600	2550
	Lower (std UC) – 2 sets stabilizers down				*10 000	*10 000	*10 000	*7300	*7300	*7300	*5800	*5800	*5800	*2600	*2600	*2600
1500 mm	MH – stabilizers up – solid tires				9050	9050	6500	6000	6000	4400	4350	4350	3200	*2650	*2650	2600
	MH – stabilizers down – solid tires				*11 400	*11 400	*11 400	*7950	*7950	*7950	*6100	*6100	*6100	*2650	*2650	*2650
	Lower (std UC) – f. stabilizer & r. dozer up				9000	8300	6200	5900	5550	4200	4250	4050	3050	*2650	*2650	2450
	Lower (std UC) – f. dozer & r. stabilizer up				*11 400	*11 400	10 150	*7950	*7950	6600	*6100	*6100	4750	*2650	*2650	*2650
	Lower (std UC) – f. dozer & r. stabilizer down				9250	8050	6200	6100	5350	4200	4400	3900	3050	*2650	*2650	2450
	Lower (std UC) – 2 sets stabilizers up				*11 400	*11 400	10 500	*7950	*7950	6800	*6100	*6100	4900	*2650	*2650	*2650
	Lower (std UC) – 2 sets stabilizers down				9200	8300	6250	6050	5500	4250	4350	4000	3100	*2650	*2650	2500
0 mm	MH – stabilizers up – solid tires				8700	8700	6200	5800	5800	4200	4250	4250	3100	*2850	*2850	2850
	MH – stabilizers down – solid tires				*11 750	*11 750	*11 750	*8500	*8500	*8500	*6450	*6450	*6450	*2850	*2850	*2850
	Lower (std UC) – f. stabilizer & r. dozer up				8650	8000	5900	5700	5350	4000	4150	3900	2950	*2850	*2850	2500
	Lower (std UC) – f. dozer & r. stabilizer up				*11 750	*11 750	9800	*8500	*8500	6400	*6450	*6450	4650	*2850	*2850	*2850
	Lower (std UC) – f. dozer & r. stabilizer down				8950	7700	5900	5900	5150	4000	4300	3800	2950	*2850	*2850	2500
	Lower (std UC) – 2 sets stabilizers up				*11 750	*11 750	10 150	*8500	*8500	6600	*6450	*6450	4800	*2850	*2850	*2850
	Lower (std UC) – 2 sets stabilizers down				8850	7950	5950	5850	5300	4050	4250	3900	3000	*2850	*2850	2550
-1500 mm	MH – stabilizers up – solid tires	*9450	*9450	*9450	8600	8600	6100	5700	5700	4100	4200	4200	3050	*3250	*3250	2850
	MH – stabilizers down – solid tires	*9450	*9450	*9450	*10 950	*10 950	*10 950	*8100	*8100	*8100	*6000	*6000	*6000	*3250	*3250	*3250
	Lower (std UC) – f. stabilizer & r. dozer up	*9450	*9450	*9450	8550	7900	5800	5600	5250	3950	4100	3900	2900	*3250	*3250	2700
	Lower (std UC) – f. dozer & r. stabilizer up	*9450	*9450	*9450	*10 950	*10 950	9700	*8100	*8100	6300	*6000	*6000	4600	*3250	*3250	*3250
	Lower (std UC) – f. dozer & r. stabilizer down	*9450	*9450	*9450	8850	7950	5800	5800	5500	3950	4250	3750	2900	*3250	*3250	2700
	Lower (std UC) – 2 sets stabilizers up	*9450	*9450	*9450	*10 950	*10 950	10 050	*8100	*8100	6500	*6000	*6000	4750	*3250	*3250	*3250
	Lower (std UC) – 2 sets stabilizers down	*9450	*9450	*9450	8800	7850	5900	5750	5200	3950	4250	3850	2950	*3250	*3250	2750
-3000 mm	MH – stabilizers up – solid tires				8700	8700	6150	5700	5700	4100	4150	4150	3050	*3250	*3250	2850
	MH – stabilizers down – solid tires				*9150	*9150	*9150	*6750	*6750	*6750	*4650	*4650	*4650	*3250	*3250	*3250
	Lower (std UC) – f. stabilizer & r. dozer up				8600	7950	5850	5650	5300	3950	4050	3850	2950	*3250	*3250	2850
	Lower (std UC) – f. dozer & r. stabilizer up				*9150	*9150	*9150	*6750	*6750	*6750	*4650	*4650	*4650	*3250	*3250	*3250
	Lower (std UC) – f. dozer & r. stabilizer down				8900	7700	5850	5800	5100	3950	4050	3850	2950	*3250	*3250	2850
	Lower (std UC) – 2 sets stabilizers up				*9150	*9150	*9150	*6750	*6750	*6750	*4650	*4650	*4650	*3250	*3250	*3250
	Lower (std UC) – 2 sets stabilizers down				8850	7900	5950	5800	5250	4000	4050	3850	2950	*3250	*3250	2850

\*Limited by hydraulic rather than tipping load.

Lift capacity ratings are based on ISO 10567:2007, they do not exceed 87% of hydraulic lifting capacity or 75% of tipping load. The load point is the center line of the bucket pivot mounting pin on the stick. The oscillating axle must be locked. Lifting capacities are based on the machine standing on a firm uniform supporting surface and the Variable Boom Cylinder adjusted to the maximum length. For lifting capacity including bucket and/or quick coupler, the respective weight has to be subtracted from above values. The use of a work tool attachment point to handle/lift objects, could affect the machine lift performance.

Always refer to the appropriate Operation and Maintenance Manual for specific product information.

Lifting Capacities  
 • MH3024  
 (Grenoble Sourced)

Material Handlers

Lift Capacities

All values are in lb, bucket cylinder and linkage installed, hydraulic cab riser, work tool: none, with counterweight (11,470 lb), heavy lift on.

Load point height

Load over front

Load over rear

Load over side

Load at maximum reach (sticknose/bucket pin)

Undercarriage

Boom  
VA

Stick  
9'6"

MH or Standard

	Undercarriage configuration	10 ft			15 ft			20 ft			25 ft				ft						
30 ft	MH – stabilizers up – solid tires														*9500	*9500	*9500				
	MH – stabilizers down – solid tires														*9500	*9500	*9500				
	Lower (std UC) – f. stabilizer & r. dozer up														*9500	*9500	*9500				
	Lower (std UC) – f. stabilizer & r. dozer down														*9500	*9500	*9500				
	Lower (std UC) – f. dozer & r. stabilizer up														*9500	*9500	*9500				
	Lower (std UC) – f. dozer & r. stabilizer down														*9500	*9500	*9500				
25 ft	MH – stabilizers up – solid tires							*9800	*9800	*9800					*7000	*7000	*7000				
	MH – stabilizers down – solid tires							*9800	*9800	*9800					*7000	*7000	*7000				
	Lower (std UC) – f. stabilizer & r. dozer up							*9800	*9800	*9800					*7000	*7000	*7000				
	Lower (std UC) – f. stabilizer & r. dozer down							*9800	*9800	*9800					*7000	*7000	*7000				
	Lower (std UC) – f. dozer & r. stabilizer up							*9800	*9800	*9800					*7000	*7000	*7000				
	Lower (std UC) – f. dozer & r. stabilizer down							*9800	*9800	*9800					*7000	*7000	*7000				
20 ft	MH – stabilizers up – solid tires							*13,800	*13,800	11,000					*6100	*6100	*6100				
	MH – stabilizers down – solid tires							*13,800	*13,800	13,800					*6100	*6100	*6100				
	Lower (std UC) – f. stabilizer & r. dozer up							*13,800	13,500	10,600					*6100	*6100	*6100				
	Lower (std UC) – f. stabilizer & r. dozer down							*13,800	*13,800	*13,800					*6100	*6100	*6100				
	Lower (std UC) – f. dozer & r. stabilizer up							*13,800	13,100	10,600					*6100	*6100	*6100				
	Lower (std UC) – f. dozer & r. stabilizer down							*13,800	*13,800	*13,800					*6100	*6100	*6100				
15 ft	MH – stabilizers up – solid tires					*17,000	*17,000	16,500	14,100	10,600	9900	9900	7400		*5800	*5800	*5800				
	MH – stabilizers down – solid tires					*17,000	*17,000	15,900	13,900	13,100	10,200	9700	9200	7100	*5800	*5800	*5800				
	Lower (std UC) – f. stabilizer & r. dozer up					*17,000	*17,000	*17,000	*17,000	*14,800	*14,800	*12,200	*12,200	10,800	*5800	*5800	*5800				
	Lower (std UC) – f. stabilizer & r. dozer down					*17,000	*17,000	15,900	14,400	12,700	10,200	10,000	8900	7100	*5800	*5800	*5800				
	Lower (std UC) – f. dozer & r. stabilizer up					*17,000	*17,000	*17,000	*14,800	*14,800	*14,800	*12,200	*12,200	11,100	*5800	*5800	*5800				
	Lower (std UC) – f. dozer & r. stabilizer down					*17,000	*17,000	16,100	14,300	13,100	10,300	10,000	9200	7200	*5800	*5800	*5800				
10 ft	MH – stabilizers up – solid tires							20,800	20,800	15,200	13,500	13,500	10,100	9700	9700	7200	*5700	*5700	*5700		
	MH – stabilizers down – solid tires							*21,500	*21,500	*21,500	*15,800	*15,800	*15,800	*12,600	*12,600	*12,600	*5700	*5700	*5700		
	Lower (std UC) – f. stabilizer & r. dozer up							20,700	19,300	14,600	13,300	12,600	9700	9500	9000	6900	*5700	*5700	5600		
	Lower (std UC) – f. stabilizer & r. dozer down							*21,500	*21,500	*21,500	*15,800	*15,800	14,900	*12,600	*12,600	10,600	*5700	*5700	*5700		
	Lower (std UC) – f. dozer & r. stabilizer up							21,400	18,700	14,000	13,800	12,200	9700	9900	8700	6900	*5700	*5700	5600		
	Lower (std UC) – f. dozer & r. stabilizer down							*21,500	*21,500	*21,500	*15,800	*15,800	15,300	*12,600	*12,600	10,900	*5700	*5700	*5700		
5 ft	MH – stabilizers up – solid tires							19,500	19,500	14,000	12,900	12,900	9500	9400	6900	*5900	*5900	5700			
	MH – stabilizers down – solid tires							*24,700	*24,700	*24,700	*17,200	*17,200	*17,200	*13,200	*13,200	*13,200	*5900	*5900	*5900		
	Lower (std UC) – f. stabilizer & r. dozer up							19,400	17,900	13,400	12,700	11,900	9100	9200	8700	6600	*5900	*5900	5400		
	Lower (std UC) – f. stabilizer & r. dozer down							*24,700	*24,700	21,900	*17,200	*17,200	14,300	*13,200	*13,200	10,300	*5900	*5900	*5900		
	Lower (std UC) – f. dozer & r. stabilizer up							20,000	17,300	13,400	13,100	11,500	9100	9500	8400	6600	*5900	*5900	5400		
	Lower (std UC) – f. dozer & r. stabilizer down							*24,700	*24,700	22,900	*17,200	*17,200	14,700	*13,200	*13,200	10,600	*5900	*5900	*5900		
0 ft	MH – stabilizers up – solid tires							18,800	18,800	13,300	12,500	12,500	9100	9100	9100	6700	*6300	*6300	5800		
	MH – stabilizers down – solid tires							*25,400	*25,400	*25,400	*18,400	*18,400	*18,400	*14,000	*14,000	*14,000	*6300	*6300	*6300		
	Lower (std UC) – f. stabilizer & r. dozer up							18,600	17,200	12,700	12,200	11,500	8700	8900	8500	6400	*6300	*6300	5500		
	Lower (std UC) – f. stabilizer & r. dozer down							*25,400	*25,400	21,100	*18,400	*18,400	13,800	*14,000	*14,000	10,000	*6300	*6300	*6300		
	Lower (std UC) – f. dozer & r. stabilizer up							19,200	16,600	12,700	12,700	11,100	8700	9300	8100	6400	*6300	*6300	5500		
	Lower (std UC) – f. dozer & r. stabilizer down							*25,400	*25,400	21,800	*18,400	*18,400	14,200	*14,000	*14,000	10,300	*6300	*6300	*6300		
-5 ft	MH – stabilizers up – solid tires					*21,500	*21,500	18,500	18,500	13,100	12,300	12,300	8900	9100	9100	6600	*7200	*7200	6300		
	MH – stabilizers down – solid tires					*21,500	*21,500	23,700	*23,700	*23,700	*17,500	*17,500	*17,500	*12,800	*12,800	*12,800	*7200	*7200	*7200		
	Lower (std UC) – f. stabilizer & r. dozer up							*21,500	*21,500	18,400	17,000	12,500	12,100	11,300	8500	8900	8400	*7200	*7200	6000	
	Lower (std UC) – f. stabilizer & r. dozer down							*21,500	*21,500	23,700	*23,700	20,800	*17,500	*17,500	13,600	*12,800	*12,800	10,000	*7200	*7200	*7200
	Lower (std UC) – f. dozer & r. stabilizer up							*21,500	*21,500	19,000	16,400	12,500	10,900	8500	9200	8100	6300	*7200	*7200	6000	
	Lower (std UC) – f. dozer & r. stabilizer down							*21,500	*21,500	23,700	*23,700	21,600	*17,500	*17,500	14,000	*12,800	*12,800	10,200	*7200	*7200	*7200
-10 ft	MH – stabilizers up – solid tires							18,700	18,700	13,300	12,400	12,400	9000				*7200	*7200	6100		
	MH – stabilizers down – solid tires							*19,700	*19,700	*19,700	*14,400	*14,400	*14,400				*7200	*7200	6100		
	Lower (std UC) – f. stabilizer & r. dozer up							18,500	17,100	12,700	12,100	11,400	8600				*7200	*7200	6100		
	Lower (std UC) – f. stabilizer & r. dozer down							*19,700	*19,700	*19,700	*14,400	*14,400	*14,400				*7200	*7200	6100		
	Lower (std UC) – f. dozer & r. stabilizer up							19,100	16,600	12,700	12,600	11,000	8600				*7200	*7200	6100		
	Lower (std UC) – f. dozer & r. stabilizer down							*19,700	*19,700	*19,700	*14,400	*14,400	*14,400				*7200	*7200	6100		

9

\*Limited by hydraulic rather than tipping load.

Lift capacity ratings are based on ISO 10567:2007, they do not exceed 87% of hydraulic lifting capacity or 75% of tipping load. The load point is the center line of the bucket pivot mounting pin on the stick. The oscillating axle must be locked. Lifting capacities are based on the machine standing on a firm uniform supporting surface and the Variable Boom Cylinder adjusted to the maximum length. For lifting capacity including bucket and/or quick coupler, the respective weight has to be subtracted from above values. The use of a work tool attachment point to handle/lift objects, could affect the machine lift performance.

Always refer to the appropriate Operation and Maintenance Manual for specific product information.

## Lift Capacities

All values are in kg, bucket cylinder and linkage installed, hydraulic cab riser, work tool: none, with counterweight (4100 kg), heavy lift on.

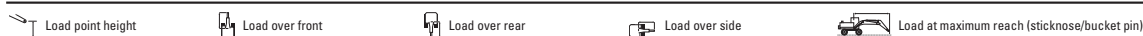

### Undercarriage

### Boom

### Stick

MH or Standard

6.8 m MH

4.8 m Straight Stick

Stick height	Undercarriage configuration	4500 mm			6000 mm			7500 mm			9000 mm			10 500 mm			Load at maximum reach (sticknose/bucket pin)			mm
		Load point height	Load over front	Load over rear	Load point height	Load over front	Load over rear	Load point height	Load over front	Load over rear	Load point height	Load over front	Load over rear	Load point height	Load over front	Load over rear	Load point height	Load over front	Load over rear	
12 000 mm	MH – stabilizers up – solid tires	*8800	*8800	7050												*7750	*7750	5950	4970	
	MH – stabilizers down – solid tires	*8800	*8800	*8800												*7750	*7750	*7750		
	Lower (std UC) – f. stabilizer & r. dozer up	*8800	*8800	6750												*7750	7450	5700		
	Lower (std UC) – f. stabilizer & r. dozer down	*8800	*8800	*8800												*7750	*7750	*7750		
	Lower (std UC) – f. dozer & r. stabilizer up	*8800	8600	6750												*7750	7200	5700		
	Lower (std UC) – f. dozer & r. stabilizer down	*8800	*8800	*8800												*7750	*7750	*7750		
	Lower (std UC) – 2 sets stabilizers up	*8800	*8800	6850												*7750	7400	5750		
Lower (std UC) – 2 sets stabilizers down	*8800	*8800	*8800												*7750	*7750	*7750			
10 500 mm	MH – stabilizers up – solid tires				6100	6100	4600									4200	4200	3100	7350	
	MH – stabilizers down – solid tires				*8850	*8850	*8850									*6150	*6150	*6150		
	Lower (std UC) – f. stabilizer & r. dozer up				6000	5700	4400									4100	3900	2950		
	Lower (std UC) – f. stabilizer & r. dozer down				*8850	*8850	6700									*6150	*6150	4600		
	Lower (std UC) – f. dozer & r. stabilizer up				6200	5500	4400									4250	3750	2950		
	Lower (std UC) – f. dozer & r. stabilizer down				*8850	*8850	6900									*6150	*6150	4750		
	Lower (std UC) – 2 sets stabilizers up				6150	5650	4450									4200	3850	2950		
Lower (std UC) – 2 sets stabilizers down				*8850	*8850	8250									*6150	*6150	5650			
9000 mm	MH – stabilizers up – solid tires				6250	6250	4700	4200	4200	3100						3000	3000	2200	8860	
	MH – stabilizers down – solid tires				*9000	*9000	*9000	*7700	*7700	6700						*5550	*5550	4900		
	Lower (std UC) – f. stabilizer & r. dozer up				6150	5800	4500	4100	3900	2950						2950	2800	2050		
	Lower (std UC) – f. stabilizer & r. dozer down				*9000	*9000	6850	*7700	*7700	4600						*5550	*5550	3300		
	Lower (std UC) – f. dozer & r. stabilizer up				6350	5600	4500	4250	3750	2950						3050	2650	2050		
	Lower (std UC) – f. dozer & r. stabilizer down				*9000	*9000	7050	*7700	6800	4700						*5550	4950	3400		
	Lower (std UC) – 2 sets stabilizers up				6300	5750	4550	4200	3850	3000						3050	2750	2100		
Lower (std UC) – 2 sets stabilizers down				*9000	*9000	8350	*7700	6950	5600						*5550	5100	4100			
7500 mm	MH – stabilizers up – solid tires				6200	6200	4650	4200	4200	3100	3000	3000	2150			2450	2450	1700	9910	
	MH – stabilizers down – solid tires				*9050	*9050	*9050	*7700	*7700	6700	6000	6000	4850			5050	5050	4050		
	Lower (std UC) – f. stabilizer & r. dozer up				6100	5750	4450	4100	3900	2950	2900	2750	2050			2350	2250	1600		
	Lower (std UC) – f. stabilizer & r. dozer down				*9050	*9050	6800	*7700	*7700	4600	5700	5600	3300			4750	4650	2700		
	Lower (std UC) – f. dozer & r. stabilizer up				6300	5550	4450	4250	3750	2950	3000	2650	2050			2450	2150	1600		
	Lower (std UC) – f. dozer & r. stabilizer down				*9050	*9050	7000	*7700	6800	4700	6400	4850	3350			*5200	4050	2750		
	Lower (std UC) – 2 sets stabilizers up				6250	5750	4500	4200	3850	3000	3000	2750	2050			2450	2200	1650		
Lower (std UC) – 2 sets stabilizers down				*9050	*9050	8300	*7700	6950	5600	5850	5050	4050			4850	4200	3350			
6000 mm	MH – stabilizers up – solid tires				6000	6000	4500	4100	4100	3000	2950	2950	2100	2150	1500	2100	2100	1450	10 640	
	MH – stabilizers down – solid tires				*9400	*9400	*7850	*7850	6600	6000	6000	4800	4550	4550	3600	4450	4450	3550		
	Lower (std UC) – f. stabilizer & r. dozer up				5900	5550	4300	4000	3800	2850	2850	2700	2000	2100	1950	1400	2000	1900		1350
	Lower (std UC) – f. stabilizer & r. dozer down				*9400	*9400	6600	7800	7600	4500	5650	5550	3250	4250	4200	2400	4150	4100		2300
	Lower (std UC) – f. dozer & r. stabilizer up				6100	5400	4300	4150	3850	2850	2950	2600	2000	2150	1850	1400	2100	1800		1350
	Lower (std UC) – f. dozer & r. stabilizer down				*9400	*9400	6800	*7850	6850	4600	6350	4850	3300	4800	3650	2450	4650	3550		2400
	Lower (std UC) – 2 sets stabilizers up				6050	5550	4350	4100	3750	2900	2950	2700	2000	2150	1950	1400	2100	1900		1350
Lower (std UC) – 2 sets stabilizers down				*9400	*9400	8100	*7850	6850	5500	5800	5000	4000	4400	3750	3000	4250	3650	2900		
4500 mm	MH – stabilizers up – solid tires	9200	9200	6700	5700	5700	4150	3900	3900	2850	2850	2850	2050	2150	1550	1900	1900	1250	11 120	
	MH – stabilizers down – solid tires	*12 850	*12 850	*12 850	*9900	*9900	9350	8000	8000	6400	5850	5850	4700	4500	4500	3600	4050	4050		3250
	Lower (std UC) – f. stabilizer & r. dozer up	9100	8450	6400	5550	5250	4000	3800	3800	2700	2750	2600	1900	2050	1950	1350	1800	1700		1150
	Lower (std UC) – f. stabilizer & r. dozer down	*12 850	*12 850	10 250	*9900	*9900	6250	7600	7400	4300	5500	5450	3150	4200	4150	2350	3800	3750		2150
	Lower (std UC) – f. dozer & r. stabilizer up	9400	8200	6400	5750	5050	4000	3950	3450	2700	2850	2500	1900	2150	1850	1350	1900	1600		1150
	Lower (std UC) – f. dozer & r. stabilizer down	*12 850	*12 850	10 600	*9900	9550	6450	*8050	6450	4450	6200	4750	3250	4750	3600	2400	4300	3250		2150
	Lower (std UC) – 2 sets stabilizers up	9350	8450	6450	5750	5250	4000	3950	3600	2750	2850	2600	1950	2150	1950	1400	1900	1700		1200
Lower (std UC) – 2 sets stabilizers down	*12 850	*12 850	*12 850	*9900	9800	7750	7800	6650	5300	5700	4900	3900	4350	3750	2950	3900	3350	2650		

\* Limited by hydraulic rather than tipping load.

(continued on next page)

Lift capacity ratings are based on ISO 10567:2007, they do not exceed 87% of hydraulic lifting capacity or 75% of tipping load. The load point is the center line of the bucket pivot mounting pin on the stick. The oscillating axle must be locked. Lifting capacities are based on the machine standing on a firm uniform supporting surface. For lifting capacity including bucket and/or quick coupler, the respective weight has to be subtracted from above values. The use of a work tool attachment point to handle/lift objects, could affect the machine lift performance.

Always refer to the appropriate Operation and Maintenance Manual for specific product information.

**Lift Capacities (continued)**

All values are in kg, bucket cylinder and linkage installed, hydraulic cab riser, work tool: none, with counterweight (4100 kg), heavy lift on.

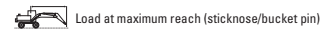
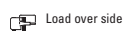
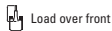

**Undercarriage**

MH or Standard

**Boom**  
6.8 m MH

**Stick**  
4.8 m Straight Stick

Load point height	Undercarriage configuration	4500 mm			6000 mm			7500 mm			9000 mm			10 500 mm			mm		
		Load over front	Load over rear	Load over side	Load over front	Load over rear	Load over side	Load over front	Load over rear	Load over side	Load over front	Load over rear	Load over side	Load over front	Load over rear	Load over side			
3000 mm	MH – stabilizers up – solid tires	8300	8300	5900	5250	5250	3800	3700	3700	2650	2750	2750	1900	2050	2050	1400	1750	1750	1150
	MH – stabilizers down – solid tires	*14 100	*14 100	*14 100	*10 400	*10 400	8850	7750	7750	6150	5750	5750	4550	4450	4450	3550	3900	3900	3050
	Lower (std UC) – f. stabilizer & r. dozer up	8200	7600	5600	5150	4850	3600	3600	3400	2500	2500	2500	1800	2000	1900	1300	1700	1600	1100
	Lower (std UC) – f. stabilizer & r. dozer down	*14 100	*14 100	9300	*10 400	*10 400	5850	7300	7150	4100	5400	5300	3000	4150	4100	2300	3600	3550	2000
	Lower (std UC) – f. dozer & r. stabilizer up	8500	7300	5600	5350	4650	3600	3750	3250	2500	2750	2400	1800	2100	1800	1300	1800	1500	1100
	Lower (std UC) – f. dozer & r. stabilizer down	*14 100	*14 100	9650	*10 400	9050	6000	*8200	6200	4200	6100	4600	3100	4700	3550	2350	4100	3100	2050
1500 mm	Lower (std UC) – 2 sets stabilizers up	8450	7550	5650	5300	4800	3650	3700	3400	2500	2750	2500	1800	2050	1850	1300	1750	1600	1100
	Lower (std UC) – 2 sets stabilizers down	*14 100	*14 100	11 900	*10 400	9300	7300	7550	6400	5100	5550	4750	3750	4300	3650	2900	3750	3200	2500
	MH – stabilizers up – solid tires	7450	7450	5100	4850	4850	3400	3450	2400	2600	2600	1800	2000	2000	1350	1700	1700	1150	
	MH – stabilizers down – solid tires	*14 450	*14 450	13 750	*10 500	*10 500	8400	7500	7500	5900	5600	5600	4400	4350	4350	3450	3800	3800	3000
	Lower (std UC) – f. stabilizer & r. dozer up	7300	6750	4850	4750	4450	3200	3350	3200	2250	2500	2350	1650	1900	1800	1250	1650	1550	1050
	Lower (std UC) – f. stabilizer & r. dozer down	*14 450	*14 450	8400	10 300	10 000	5400	7050	6900	3850	5250	5150	2900	4100	4000	2250	3550	3500	1900
0 mm	Lower (std UC) – f. dozer & r. stabilizer up	7600	6500	4850	4950	4250	3200	3500	3050	2250	2600	2250	1650	2000	1700	1250	1750	1450	1050
	Lower (std UC) – f. dozer & r. stabilizer down	*14 450	14 200	8750	*10 500	8550	5600	8000	5950	3950	5950	4450	2950	4600	3450	2300	*4000	3000	2000
	Lower (std UC) – 2 sets stabilizers up	7550	6750	4900	4900	4400	3250	3500	3150	2300	2600	2350	1700	2000	1800	1250	1700	1550	1050
	Lower (std UC) – 2 sets stabilizers down	*14 450	*14 450	10 950	*10 500	8800	6850	7250	6150	4850	5400	4600	3650	4200	3600	2800	3650	3150	2450
	MH – stabilizers up – solid tires	6900	6900	4650	4550	4550	3100	3300	3300	2250	2500	2500	1700	1950	1950	1300			
	MH – stabilizers down – solid tires	*9550	*9550	*9550	*9900	*9900	8050	7250	7250	5700	5450	5450	4300	4300	4300	3400			
-1500 mm	Lower (std UC) – f. stabilizer & r. dozer up	6800	6250	4350	4450	4150	2900	3200	3000	2100	2400	2250	1550	1850	1750	1200			
	Lower (std UC) – f. stabilizer & r. dozer down	*9550	*9550	7850	*9900	9600	5100	6850	6700	3650	5100	5000	2800	4000	3950	2200			
	Lower (std UC) – f. dozer & r. stabilizer up	7100	6000	4350	4600	3950	2900	3300	2850	2100	2500	2150	1550	1950	1650	1200			
	Lower (std UC) – f. dozer & r. stabilizer down	*9550	*9550	8200	*9900	8200	5250	*7650	5750	3900	5800	4350	2850	*4450	3400	2250			
	Lower (std UC) – 2 sets stabilizers up	7050	6250	4450	4600	4100	2950	3300	3000	2150	2500	2250	1600	1950	1750	1200			
	Lower (std UC) – 2 sets stabilizers down	*9550	*9550	*9550	*9900	8450	6500	7050	5950	4650	5250	4500	3500	4150	3550	2750			

\*Limited by hydraulic rather than tipping load.

Lift capacity ratings are based on ISO 10567:2007, they do not exceed 87% of hydraulic lifting capacity or 75% of tipping load. The load point is the center line of the bucket pivot mounting pin on the stick. The oscillating axle must be locked. Lifting capacities are based on the machine standing on a firm uniform supporting surface. For lifting capacity including bucket and/or quick coupler, the respective weight has to be subtracted from above values. The use of a work tool attachment point to handle/lift objects, could affect the machine lift performance.

Always refer to the appropriate Operation and Maintenance Manual for specific product information.

**Lift Capacities**

All values are in lb, bucket cylinder and linkage installed, hydraulic cab riser, work tool: none, with counterweight (9040 lb), heavy lift on.



**Undercarriage**      **Boom**      **Stick**  
 MH or Standard      22'4" MH      15'9" Straight Stick

Stick ft	Undercarriage configuration	15 ft			20 ft			25 ft			30 ft			35 ft			ft					
		Load point height	Load over front	Load over rear	Load point height	Load over front	Load over rear	Load point height	Load over front	Load over rear	Load point height	Load over front	Load over rear	Load point height	Load over front	Load over rear						
40 ft	MH – stabilizers up – solid tires																					
	MH – stabilizers down – solid tires																					
	Lower (std UC) – f. stabilizer & r. dozer up																					
	Lower (std UC) – f. stabilizer & r. dozer down																					
	Lower (std UC) – f. dozer & r. stabilizer up																					
	Lower (std UC) – f. dozer & r. stabilizer down																					
	Lower (std UC) – 2 sets stabilizers up																					
35 ft	MH – stabilizers up – solid tires				13,100	13,100	9800											9700	9700	7200		
	MH – stabilizers down – solid tires				*18,800	*18,800	*18,800											*13,800	*13,800	*13,800		
	Lower (std UC) – f. stabilizer & r. dozer up				12,800	12,100	9300											9500	9000	6800		
	Lower (std UC) – f. stabilizer & r. dozer down				*18,800	*18,800	14,300											*13,800	*13,800	10,700		
	Lower (std UC) – f. dozer & r. stabilizer up				13,200	11,700	9300											9800	8700	6800		
	Lower (std UC) – f. dozer & r. stabilizer down				*18,800	*18,800	14,700											*13,800	*13,800	11,000		
	Lower (std UC) – 2 sets stabilizers up				13,200	12,100	9400											9800	9000	6900		
30 ft	MH – stabilizers up – solid tires				13,400	13,400	10,100	9000	9000	6600								6800	6800	4900		
	MH – stabilizers down – solid tires				*19,600	*19,600	*19,600	*16,800	*16,800	14,300								*12,300	*12,300	11,100		
	Lower (std UC) – f. stabilizer & r. dozer up				13,100	12,400	9600	8800	8300	6300								6600	6300	4700		
	Lower (std UC) – f. stabilizer & r. dozer down				*19,600	*19,600	14,700	*16,800	16,600	9800								*12,300	*12,300	7500		
	Lower (std UC) – f. dozer & r. stabilizer up				13,600	12,000	9600	9100	8000	6300								6900	6000	4700		
	Lower (std UC) – f. dozer & r. stabilizer down				*19,600	*19,600	15,100	*16,800	14,500	10,100								*12,300	11,200	7700		
	Lower (std UC) – 2 sets stabilizers up				13,500	12,400	9700	9000	8300	6400								6800	6300	4700		
25 ft	MH – stabilizers up – solid tires				13,300	13,300	10,000	9000	9000	6700	6400	6400	4600					5500	5500	3800		
	MH – stabilizers down – solid tires				*19,700	*19,700	*19,700	*16,700	*16,700	14,400	12,900	12,900	10,400					11,300	11,300	9000		
	Lower (std UC) – f. stabilizer & r. dozer up				13,100	12,400	9600	8800	8300	6300	6200	5900	4300					5300	5000	3600		
	Lower (std UC) – f. stabilizer & r. dozer down				*19,700	*19,700	14,600	*16,700	16,600	9900	12,200	11,900	7000					10,600	10,400	6000		
	Lower (std UC) – f. dozer & r. stabilizer up				13,500	12,000	9600	9100	8000	6300	6400	5600	4300					5500	4800	3600		
	Lower (std UC) – f. dozer & r. stabilizer down				*19,700	*19,700	15,000	*16,700	14,500	10,100	13,700	10,400	7200					*11,600	9100	6200		
	Lower (std UC) – 2 sets stabilizers up				13,400	12,300	9700	9000	8300	6400	6400	5800	4400					5400	5000	3600		
20 ft	MH – stabilizers up – solid tires				12,900	12,900	9600	8800	8800	6500	6300	6300	4500					4700	4700	3200		
	MH – stabilizers down – solid tires				*20,400	*20,400	*20,400	*17,000	*17,000	14,100	12,800	12,800	10,300					8800	8800	7800		
	Lower (std UC) – f. stabilizer & r. dozer up				12,700	12,000	9200	8600	8100	6200	6100	5800	4300					4500	4200	3000		
	Lower (std UC) – f. stabilizer & r. dozer down				*20,400	*20,400	14,200	16,700	16,400	9700	12,100	11,900	6900					9200	9100	5200		
	Lower (std UC) – f. dozer & r. stabilizer up				13,100	11,600	9200	8900	7800	6200	6400	5600	4300					4700	4000	3000		
	Lower (std UC) – f. dozer & r. stabilizer down				*20,400	*20,400	14,600	*17,000	14,300	9900	13,600	10,400	7100					10,400	7900	5300		
	Lower (std UC) – 2 sets stabilizers up				13,000	11,900	9300	8800	8100	6200	6300	5800	4300					4600	4200	3000		
15 ft	MH – stabilizers up – solid tires				19,800	19,800	14,400	12,200	12,200	9000	8400	8400	6100	6100	4300	4600	4600	3100	4200	4200	2800	
	MH – stabilizers down – solid tires				*27,800	*27,800	*27,800	*21,500	*21,500	20,100	17,200	17,200	13,700	12,600	12,600	10,100	9700	9700	7700	9000	9000	7200
	Lower (std UC) – f. stabilizer & r. dozer up				19,600	18,300	13,800	12,000	11,300	8600	8200	7800	5800	5900	5600	4100	4400	4100	2900	4000	3800	2600
	Lower (std UC) – f. stabilizer & r. dozer down				*27,800	*27,800	22,000	*21,500	*21,500	13,500	16,300	15,900	9300	11,900	11,700	6700	9000	8900	5000	8400	8300	4600
	Lower (std UC) – f. dozer & r. stabilizer up				20,200	17,700	13,800	12,400	10,900	8600	8500	7500	5800	6200	5400	4100	4600	3900	2900	4200	3600	2600
	Lower (std UC) – f. dozer & r. stabilizer down				*27,800	*27,800	22,800	*21,500	20,500	13,900	*17,500	13,900	9500	13,400	10,200	6900	10,200	7700	5200	9500	7200	4800
	Lower (std UC) – 2 sets stabilizers up				20,100	18,200	14,000	12,300	11,300	8700	8500	7700	5900	6100	5600	4100	4500	4100	2900	4200	3800	2600
				*27,800	*27,800	27,800	*21,500	21,000	16,700	16,700	14,300	11,400	12,200	10,500	8400	9300	8000	6300	8700	7400	5900	

\*Limited by hydraulic rather than tipping load.

(continued on next page)

Lift capacity ratings are based on ISO 10567:2007, they do not exceed 87% of hydraulic lifting capacity or 75% of tipping load. The load point is the center line of the bucket pivot mounting pin on the stick. The oscillating axle must be locked. Lifting capacities are based on the machine standing on a firm uniform supporting surface. For lifting capacity including bucket and/or quick coupler, the respective weight has to be subtracted from above values. The use of a work tool attachment point to handle/lift objects, could affect the machine lift performance.

Always refer to the appropriate Operation and Maintenance Manual for specific product information.

**Lift Capacities (continued)**

All values are in lb, bucket cylinder and linkage installed, hydraulic cab riser, work tool: none, with counterweight (9040 lb), heavy lift on.



**Undercarriage**

**Boom**  
22" MH

**Stick**  
15'9" Straight Stick

MH or Standard

Load point height	Undercarriage configuration	15 ft			20 ft			25 ft			30 ft			35 ft			ft			
		Load over front	Load over rear	Load over side	Load over front	Load over rear	Load over side	Load over front	Load over rear	Load over side	Load over front	Load over rear	Load over side	Load over front	Load over rear	Load over side				
10 ft	MH – stabilizers up – solid tires	17,900	17,900	12,700	11,400	11,400	8200	8000	8000	5700	5900	5900	4100	4400	4400	3000	3900	3900	2600	37.30
	MH – stabilizers down – solid tires	*30,500	*30,500	*30,500	*22,500	*22,500	19,100	16,700	16,700	13,200	12,300	12,300	9800	9500	9500	7600	8600	8600	6800	
	Lower (std UC) – f. stabilizer & r. dozer up	17,700	16,400	12,100	11,100	10,500	7700	7700	7300	5300	5700	5400	3800	4200	4000	2800	3700	3500	2400	
	Lower (std UC) – f. stabilizer & r. dozer down	*30,500	*30,500	20,100	*22,500	22,500	12,600	15,700	15,400	8800	11,600	11,400	6500	8900	8800	4900	8000	7900	4400	
	Lower (std UC) – f. dozer & r. stabilizer up	18,300	15,800	12,100	11,500	10,100	7700	8000	7000	5300	5900	5100	3800	4500	3800	2800	3900	3300	2400	
	Lower (std UC) – f. dozer & r. stabilizer down	*30,500	*30,500	20,800	*22,500	19,400	13,000	17,800	13,300	9000	13,100	9900	6700	10,100	7600	5100	9000	6800	4500	
5 ft	MH – stabilizers up – solid tires	16,000	16,000	11,000	10,500	10,500	7300	7500	7500	5200	5600	5600	3800	4300	4300	2900	3800	3800	2500	37.50
	MH – stabilizers down – solid tires	*31,300	*31,300	29,400	*22,800	*22,800	18,100	16,100	16,100	12,700	12,000	12,000	9500	9400	9400	7400	8400	8400	6600	
	Lower (std UC) – f. stabilizer & r. dozer up	15,800	14,600	10,400	10,200	9600	6900	7200	6800	4900	5400	5100	3600	4100	3900	2600	3600	3400	2300	
	Lower (std UC) – f. stabilizer & r. dozer down	*31,300	*31,300	18,100	22,100	21,400	11,700	15,200	14,800	8300	11,300	11,100	6200	8800	8600	4800	7800	7700	4200	
	Lower (std UC) – f. dozer & r. stabilizer up	16,400	14,000	10,400	10,600	9200	6900	7600	6500	4900	5600	4800	3600	4300	3700	2600	3800	3200	2200	
	Lower (std UC) – f. dozer & r. stabilizer down	*31,300	30,400	18,400	*22,800	18,400	12,000	17,200	12,800	8500	12,700	9600	6400	9900	7500	4900	*8800	6700	4400	
0 ft	MH – stabilizers up – solid tires	14,900	14,900	10,000	9800	9800	6700	7100	7100	4800	5400	5400	3600	4200	4200	2800	3800	3800	2800	37.50
	MH – stabilizers down – solid tires	*22,400	*22,400	*22,400	*21,500	*21,500	17,300	15,600	15,600	12,200	11,800	11,800	9300	9300	9300	7300	8300	8300	6600	
	Lower (std UC) – f. stabilizer & r. dozer up	14,600	13,500	9400	9500	8900	6300	6800	6500	4500	5200	4900	3300	4000	3800	2500	3600	3400	2300	
	Lower (std UC) – f. stabilizer & r. dozer down	*22,400	*22,400	16,900	21,300	20,600	11,000	14,700	14,400	7900	11,000	10,800	6000	8600	8500	4700	7800	7700	4200	
	Lower (std UC) – f. dozer & r. stabilizer up	15,200	12,900	9400	10,000	8500	6300	7200	6100	4500	5400	4600	3300	4200	3600	2500	3600	3400	2300	
	Lower (std UC) – f. dozer & r. stabilizer down	*22,400	*22,400	17,600	*21,500	17,600	11,300	*16,600	12,400	8100	12,500	9300	6100	*9400	7300	4800	8300	8200	6600	
-5 ft	MH – stabilizers up – solid tires				9500	9500	6400	6800	6800	4600										37.50
	MH – stabilizers down – solid tires				*18,300	*18,300	16,900	*14,200	*14,200	12,900										
	Lower (std UC) – f. stabilizer & r. dozer up				9200	8600	6000	6600	6200	4300										
	Lower (std UC) – f. stabilizer & r. dozer down				*18,300	*18,300	10,600	*14,200	14,100	7600										
	Lower (std UC) – f. dozer & r. stabilizer up				9600	8200	6000	6900	5900	4300										
	Lower (std UC) – f. dozer & r. stabilizer down				*18,300	17,200	11,000	*14,200	12,100	7900										

\*Limited by hydraulic rather than tipping load.

Lift capacity ratings are based on ISO 10567:2007, they do not exceed 87% of hydraulic lifting capacity or 75% of tipping load. The load point is the center line of the bucket pivot mounting pin on the stick. The oscillating axle must be locked. Lifting capacities are based on the machine standing on a firm uniform supporting surface. For lifting capacity including bucket and/or quick coupler, the respective weight has to be subtracted from above values. The use of a work tool attachment point to handle/lift objects, could affect the machine lift performance.

Always refer to the appropriate Operation and Maintenance Manual for specific product information.



### Lift Capacities

All values are in kg, bucket cylinder and linkage installed, hydraulic cab riser, work tool: none, with counterweight (5200 kg), heavy lift on.

		Load point height			Load over front			Load over rear			Load over side			Load at maximum reach (sticknose/bucket pin)					
		Boom												Stick					
		6.8 m MH												4.8 m Straight Stick					
		4500 mm			6000 mm			7500 mm			9000 mm			10 500 mm					
		mm																	
Undercarriage configuration		mm																	
12 000 mm	MH – stabilizers up – solid tires	*8800	*8800	7900													*7750	*7750	6700
	MH – stabilizers down – solid tires	*8800	*8800	*8800													*7750	*7750	*7750
	Lower (std UC) – f. stabilizer & r. dozer up	*8800	*8800	7600													*7750	*7750	6450
	Lower (std UC) – f. stabilizer & r. dozer down	*8800	*8800	*8800													*7750	*7750	*7750
	Lower (std UC) – f. dozer & r. stabilizer up	*8800	*8800	7600													*7750	*7750	6450
	Lower (std UC) – f. dozer & r. stabilizer down	*8800	*8800	*8800													*7750	*7750	*7750
	Lower (std UC) – 2 sets stabilizers up	*8800	*8800	7700													*7750	*7750	6500
Lower (std UC) – 2 sets stabilizers down	*8800	*8800	*8800													*7750	*7750	*7750	
10 500 mm	MH – stabilizers up – solid tires				6800	6800	5150										4750	4750	3550
	MH – stabilizers down – solid tires				*8850	*8850	*8850										*6150	*6150	*6150
	Lower (std UC) – f. stabilizer & r. dozer up				6750	6350	4950										4650	4400	3400
	Lower (std UC) – f. stabilizer & r. dozer down				*8850	*8850	7450										*6150	*6150	5200
	Lower (std UC) – f. dozer & r. stabilizer up				6900	6150	4950										4800	4250	3400
	Lower (std UC) – f. dozer & r. stabilizer down				*8850	*8850	7650										*6150	*6150	5300
	Lower (std UC) – 2 sets stabilizers up				6900	6300	5000										4750	4400	3450
Lower (std UC) – 2 sets stabilizers down				*8850	*8850	*8850										*6150	*6150	*6150	
9000 mm	MH – stabilizers up – solid tires				6950	6950	5300	4700	4700	3550							3450	3450	2550
	MH – stabilizers down – solid tires				*9000	*9000	*9000	*7700	*7700	7350							*5550	*5550	5450
	Lower (std UC) – f. stabilizer & r. dozer up				6850	6450	5100	4650	4400	3400							3350	3200	2400
	Lower (std UC) – f. stabilizer & r. dozer down				*9000	*9000	7600	*7700	*7700	5150							*5550	*5550	3800
	Lower (std UC) – f. dozer & r. stabilizer up				7050	6250	5100	4800	4250	3400							3500	3100	2400
	Lower (std UC) – f. dozer & r. stabilizer down				*9000	*9000	7800	*7700	7500	5300							*5550	5500	3850
	Lower (std UC) – 2 sets stabilizers up				7000	6450	5150	4750	4400	3450							3450	3200	2450
Lower (std UC) – 2 sets stabilizers down				*9000	*9000	*9000	*7700	7650	6250							*5550	*5550	4800	
7500 mm	MH – stabilizers up – solid tires				6900	6900	5250	4700	4700	3550	3400	3400	2500						
	MH – stabilizers down – solid tires				*9050	*9050	*9050	*7700	*7700	7350	6600	6600	5350						
	Lower (std UC) – f. stabilizer & r. dozer up				6800	6400	5050	4650	4400	3400	3300	3150	2400						
	Lower (std UC) – f. stabilizer & r. dozer down				*9050	*9050	7550	*7700	*7700	5150	6300	6150	3700						
	Lower (std UC) – f. dozer & r. stabilizer up				7000	6250	5050	4800	4250	3400	3450	3050	2400						
	Lower (std UC) – f. dozer & r. stabilizer down				*9050	*9050	7750	*7700	7450	5300	*6650	5400	3800						
	Lower (std UC) – 2 sets stabilizers up				6950	6400	5100	4750	4350	3450	3400	3150	2450						
Lower (std UC) – 2 sets stabilizers down				*9050	*9050	*9050	*7700	7650	6250	6450	5550	4500							
6000 mm	MH – stabilizers up – solid tires				6700	6700	5050	4600	4600	3450	3350	3350	2500	2500	1800	2450	2450	1750	
	MH – stabilizers down – solid tires				*9400	*9400	*9400	*7850	*7850	7250	6600	6600	5300	5050	4050	4900	4900	3950	
	Lower (std UC) – f. stabilizer & r. dozer up				6600	6250	4850	4550	4300	3300	3300	3100	2350	2450	1700	2350	2250	1650	
	Lower (std UC) – f. stabilizer & r. dozer down				*9400	*9400	7350	*7850	*7850	5050	6250	6100	3700	4750	4650	4650	4550	2700	
	Lower (std UC) – f. dozer & r. stabilizer up				6800	6050	4850	4700	4150	3300	3400	3000	2350	2550	2200	1700	2450	1150	
	Lower (std UC) – f. dozer & r. stabilizer down				*9400	*9400	7550	*7850	7350	5200	*6650	5400	3800	5300	4100	2850	*5100	2100	1650
	Lower (std UC) – 2 sets stabilizers up				6750	6200	4900	4650	4250	3350	3400	3100	2400	2500	2300	1700	2450	1250	1650
Lower (std UC) – 2 sets stabilizers down				*9400	*9400	8950	*7850	7550	6100	6400	5550	4500	4850	4200	3400	4750	4100	3300	
4500 mm	MH – stabilizers up – solid tires	10 200	10 200	7550	8350	8350	4750	4450	4450	3300	3250	3250	2400	2500	2500	1750	2200	2200	1550
	MH – stabilizers down – solid tires	*12 850	*12 850	*12 850	*9900	*9900	*9900	*8050	*8050	7050	6450	6450	5200	5000	5000	4050	4550	3850	
	Lower (std UC) – f. stabilizer & r. dozer up	10 150	9450	7250	8300	5900	4550	4350	4100	3150	3200	3000	2250	2400	2300	1650	2150	2050	1450
	Lower (std UC) – f. stabilizer & r. dozer down	*12 850	*12 850	11 350	*9900	*9900	7000	*8050	*8050	4850	6150	6000	3600	4700	4650	2750	4250	4200	2450
	Lower (std UC) – f. dozer & r. stabilizer up	10 450	9150	7250	8500	5750	4550	4500	4000	3150	3300	2900	2250	2500	2200	1650	2250	1950	1450
	Lower (std UC) – f. dozer & r. stabilizer down	*12 850	*12 850	11 750	*9900	*9900	7200	*8050	7150	5000	*6700	5300	3700	5300	4050	2800	4800	3650	2500
	Lower (std UC) – 2 sets stabilizers up	10 400	9400	7300	6450	5900	4600	4450	4100	3200	3300	3000	2300	2500	2250	1700	2200	2000	1500
Lower (std UC) – 2 sets stabilizers down	*12 850	*12 850	*12 850	*9900	*9900	8600	*8050	7350	5950	6300	5450	4400	4850	4200	3350	4400	3800	3050	

\* Limited by hydraulic rather than tipping load.

(continued on next page)

Lift capacity ratings are based on ISO 10567:2007, they do not exceed 87% of hydraulic lifting capacity or 75% of tipping load. The load point is the center line of the bucket pivot mounting pin on the stick. The oscillating axle must be locked. Lifting capacities are based on the machine standing on a firm uniform supporting surface. For lifting capacity including bucket and/or quick coupler, the respective weight has to be subtracted from above values. The use of a work tool attachment point to handle/lift objects, could affect the machine lift performance.

Always refer to the appropriate Operation and Maintenance Manual for specific product information.

**Lift Capacities (continued)**

All values are in kg, bucket cylinder and linkage installed, hydraulic cab riser, work tool: none, with counterweight (5200 kg), heavy lift on.



**Undercarriage**

MH or Standard

**Boom**

6.8 m MH

**Stick**

4.8 m Straight Stick

Stick height	Undercarriage configuration	4500 mm			6000 mm			7500 mm			9000 mm			10 500 mm			mm		
		Load point height	Load over front	Load over rear	Load point height	Load over front	Load over rear	Load point height	Load over front	Load over rear	Load point height	Load over front	Load over rear	Load point height	Load over front	Load over rear			
3000 mm	MH – stabilizers up – solid tires	9300	9300	6750	5950	5950	4400	4200	4200	3100	3150	3150	2250	2400	2400	1700	2100	2100	1450
	MH – stabilizers down – solid tires	*14 100	*14 100	*14 100	*10 400	*10 400	9800	*8200	*8200	6800	6350	6350	5100	4950	4950	3950	4300	4300	3450
	Lower (std UC) – f. stabilizer & r. dozer up	9250	8550	6450	5850	5500	4200	4100	3900	2950	3050	2900	2150	2350	2200	1600	2000	1900	1350
	Lower (std UC) – f. stabilizer & r. dozer down	*14 100	*14 100	10 450	*10 400	*10 400	6600	8100	7900	4650	6000	5850	3450	4650	4550	2650	4050	4000	2300
	Lower (std UC) – f. dozer & r. stabilizer up	9550	8300	6450	6050	5300	4200	4250	3750	2950	3200	2800	2150	2450	2100	1600	2100	1800	1350
	Lower (std UC) – f. dozer & r. stabilizer down	*14 100	*14 100	10 800	*10 400	10 000	6800	*8200	6900	4750	*6700	5150	3550	5200	4000	2750	*4500	3500	2350
1500 mm	Lower (std UC) – 2 sets stabilizers up	9500	8550	6500	6000	5500	4250	4250	3900	2950	3150	2900	2200	2400	2200	1650	2100	1900	1400
	Lower (std UC) – 2 sets stabilizers down	*14 100	*14 100	13 250	*10 400	10 300	8150	*8200	7100	5700	6150	5300	4250	4750	4100	3300	4200	3600	2850
	MH – stabilizers up – solid tires	8450	8450	5950	5550	5550	4000	4000	4000	2900	3000	3000	2150	2350	2350	1650	2050	2050	1400
	MH – stabilizers down – solid tires	*14 450	*14 450	*14 450	*10 500	*10 500	9300	*8150	*8150	6550	6200	6200	4950	4850	4850	3900	*4000	*4000	3400
	Lower (std UC) – f. stabilizer & r. dozer up	8400	7750	5650	5450	5100	3800	3900	3700	2750	2950	2800	2050	2300	2150	1550	1950	1850	1300
	Lower (std UC) – f. stabilizer & r. dozer down	*14 450	*14 450	9550	*10 500	*10 500	6150	7850	7650	4400	5850	5700	3350	4550	4500	2600	4000	3950	2250
0 mm	Lower (std UC) – f. dozer & r. stabilizer up	8650	7450	5650	5650	4900	3800	4050	3550	2750	3050	2650	2050	2350	2050	1550	2050	1750	1300
	Lower (std UC) – f. dozer & r. stabilizer down	*14 450	*14 450	9900	*10 500	9500	6350	*8150	6650	4550	*6500	5000	3400	*5100	3900	2650	*4000	3450	2300
	Lower (std UC) – 2 sets stabilizers up	8600	7700	5750	5600	5100	3850	4000	3650	2750	3050	2750	2050	2350	2150	1550	2050	1850	1350
	Lower (std UC) – 2 sets stabilizers down	*14 450	*14 450	12 250	*10 500	9800	7700	8050	6850	5450	6000	5150	4100	4700	4050	3250	*4000	3550	2800
	MH – stabilizers up – solid tires	7950	7950	5500	5250	5250	3700	3800	3800	2700	2900	2900	2050	2300	2300	1600	2050	2050	1400
	MH – stabilizers down – solid tires	*9550	*9550	*9550	*9900	*9900	8950	*7650	*7650	6350	*6000	*6000	4850	*4450	*4450	3850			
-1500 mm	Lower (std UC) – f. stabilizer & r. dozer up	7850	7250	5200	5150	4800	3500	3700	3500	2550	2850	2650	1950	2200	2100	1500			
	Lower (std UC) – f. stabilizer & r. dozer down	*9550	*9550	9000	*9900	*9900	5850	7600	7400	4200	5700	5600	3200	*4450	4450	2550			
	Lower (std UC) – f. dozer & r. stabilizer up	8150	6950	5200	5350	4600	3500	3850	3350	2550	2950	2550	1950	2300	2000	1500			
	Lower (std UC) – f. dozer & r. stabilizer down	*9550	*9550	9350	*9900	9150	6050	*7650	6450	4350	*6000	4900	3300	*4450	3850	2600			
	Lower (std UC) – 2 sets stabilizers up	8100	7200	5250	5300	4800	3550	3850	3500	2600	2900	2650	1950	2300	2100	1500			
	Lower (std UC) – 2 sets stabilizers down	*9550	*9550	*9550	*9900	9450	7350	*7650	6650	5250	5900	5050	4000	*4450	4000	3150			

\*Limited by hydraulic rather than tipping load.

Lift capacity ratings are based on ISO 10567:2007, they do not exceed 87% of hydraulic lifting capacity or 75% of tipping load. The load point is the center line of the bucket pivot mounting pin on the stick. The oscillating axle must be locked. Lifting capacities are based on the machine standing on a firm uniform supporting surface. For lifting capacity including bucket and/or quick coupler, the respective weight has to be subtracted from above values. The use of a work tool attachment point to handle/lift objects, could affect the machine lift performance.

Always refer to the appropriate Operation and Maintenance Manual for specific product information.

**Lift Capacities**

All values are in lb, bucket cylinder and linkage installed, hydraulic cab riser, work tool: none, with counterweight (11,470 lb), heavy lift on.

		Load point height			Load over front			Load over rear			Load over side			Load at maximum reach (sticknose/bucket pin)												
		<b>Undercarriage</b>						<b>Boom</b>						<b>Stick</b>												
		MH or Standard						22'4" MH						15'9" Straight Stick												
	Undercarriage configuration	15 ft			20 ft			25 ft			30 ft			35 ft						ft						
40 ft	MH – stabilizers up – solid tires																									
	MH – stabilizers down – solid tires																									
	Lower (std UC) – f. stabilizer & r. dozer up																									
	Lower (std UC) – f. stabilizer & r. dozer down																									
	Lower (std UC) – f. dozer & r. stabilizer up																									
	Lower (std UC) – f. dozer & r. stabilizer down																									
	Lower (std UC) – 2 sets stabilizers up																									
35 ft	MH – stabilizers up – solid tires																									
	MH – stabilizers down – solid tires																									
	Lower (std UC) – f. stabilizer & r. dozer up																									
	Lower (std UC) – f. stabilizer & r. dozer down																									
	Lower (std UC) – f. dozer & r. stabilizer up																									
	Lower (std UC) – f. dozer & r. stabilizer down																									
	Lower (std UC) – 2 sets stabilizers up																									
30 ft	MH – stabilizers up – solid tires																									
	MH – stabilizers down – solid tires																									
	Lower (std UC) – f. stabilizer & r. dozer up																									
	Lower (std UC) – f. stabilizer & r. dozer down																									
	Lower (std UC) – f. dozer & r. stabilizer up																									
	Lower (std UC) – f. dozer & r. stabilizer down																									
	Lower (std UC) – 2 sets stabilizers up																									
25 ft	MH – stabilizers up – solid tires																									
	MH – stabilizers down – solid tires																									
	Lower (std UC) – f. stabilizer & r. dozer up																									
	Lower (std UC) – f. stabilizer & r. dozer down																									
	Lower (std UC) – f. dozer & r. stabilizer up																									
	Lower (std UC) – f. dozer & r. stabilizer down																									
	Lower (std UC) – 2 sets stabilizers up																									
20 ft	MH – stabilizers up – solid tires																									
	MH – stabilizers down – solid tires																									
	Lower (std UC) – f. stabilizer & r. dozer up																									
	Lower (std UC) – f. stabilizer & r. dozer down																									
	Lower (std UC) – f. dozer & r. stabilizer up																									
	Lower (std UC) – f. dozer & r. stabilizer down																									
	Lower (std UC) – 2 sets stabilizers up																									
15 ft	MH – stabilizers up – solid tires																									
	MH – stabilizers down – solid tires																									
	Lower (std UC) – f. stabilizer & r. dozer up																									
	Lower (std UC) – f. stabilizer & r. dozer down																									
	Lower (std UC) – f. dozer & r. stabilizer up																									
	Lower (std UC) – f. dozer & r. stabilizer down																									
	Lower (std UC) – 2 sets stabilizers up																									

\* Limited by hydraulic rather than tipping load.

(continued on next page)

Lift capacity ratings are based on ISO 10567:2007, they do not exceed 87% of hydraulic lifting capacity or 75% of tipping load. The load point is the center line of the bucket pivot mounting pin on the stick. The oscillating axle must be locked. Lifting capacities are based on the machine standing on a firm uniform supporting surface. For lifting capacity including bucket and/or quick coupler, the respective weight has to be subtracted from above values. The use of a work tool attachment point to handle/lift objects, could affect the machine lift performance.

Always refer to the appropriate Operation and Maintenance Manual for specific product information.

**Lift Capacities (continued)**

All values are in lb, bucket cylinder and linkage installed, hydraulic cab riser, work tool: none, with counterweight (11,470 lb), heavy lift on.



**Undercarriage**

**Boom**  
22" MH

**Stick**  
15'9" Straight Stick

MH or Standard

Stick ft	Undercarriage configuration	15 ft			20 ft			25 ft			30 ft			35 ft			ft		
		Load point height	Load over front	Load over rear	Load over rear	Load over rear	Load over side	Load over side	Load over side	Load at maximum reach (sticknose/bucket pin)	Load at maximum reach (sticknose/bucket pin)	Load at maximum reach (sticknose/bucket pin)	Load at maximum reach (sticknose/bucket pin)	Load at maximum reach (sticknose/bucket pin)					
10 ft	MH – stabilizers up – solid tires	20,100	20,100	14,500	12,900	12,900	9,400	9,100	6,700	6,800	6,800	4,900	5,200	5,200	3,700	4,600	4,600	3,200	
	MH – stabilizers down – solid tires	*30,500	*30,500	*30,500	*22,500	*22,500	21,100	*17,800	*17,800	14,600	13,600	13,600	10,900	10,600	10,600	8,500	9,500	9,500	7,700
	Lower (std UC) – f. stabilizer & r. dozer up	19,900	18,500	13,900	12,600	11,900	9,000	8,900	8,400	6,300	6,600	6,200	4,600	5,000	4,800	3,400	4,500	4,200	3,000
	Lower (std UC) – f. stabilizer & r. dozer down	*30,500	*30,500	22,500	*22,500	*22,500	14,200	17,400	17,000	10,000	12,900	12,600	7,400	10,000	9,800	5,700	9,000	8,800	5,100
	Lower (std UC) – f. dozer & r. stabilizer up	20,600	17,900	13,900	13,100	11,500	9,000	9,200	8,100	6,300	6,800	6,000	4,600	5,200	4,600	3,400	4,700	4,000	3,000
	Lower (std UC) – f. dozer & r. stabilizer down	*30,500	*30,500	23,200	*22,500	21,500	14,600	*17,800	14,900	10,300	14,400	11,100	7,600	11,200	8,600	5,900	*10,000	7,700	5,200
5 ft	Lower (std UC) – 2 sets stabilizers up	20,500	18,400	14,100	13,000	11,800	9,100	9,100	8,400	6,400	6,800	6,200	4,700	5,200	4,700	3,500	4,600	4,200	3,000
	Lower (std UC) – 2 sets stabilizers down	*30,500	*30,500	28,400	*22,500	22,100	17,500	*17,800	15,300	12,300	13,200	11,400	9,100	10,300	8,800	7,100	9,200	8,000	6,300
	MH – stabilizers up – solid tires	18,200	18,200	12,900	12,000	12,000	8,600	8,600	8,600	6,200	6,500	6,500	4,600	5,100	5,100	3,500	4,500	4,500	3,100
	MH – stabilizers down – solid tires	*31,300	*31,300	*31,300	*22,800	*22,800	20,000	*17,600	*17,600	14,100	13,300	13,300	10,600	10,400	10,400	8,400	*8,800	*8,800	7,500
	Lower (std UC) – f. stabilizer & r. dozer up	18,100	16,700	12,300	11,700	11,000	8,200	8,400	7,900	5,900	6,300	6,000	4,400	4,900	4,600	3,300	4,300	4,100	2,900
	Lower (std UC) – f. stabilizer & r. dozer down	*31,300	*31,300	20,500	*22,800	*22,800	13,300	16,800	16,400	9,500	12,600	12,300	7,200	9,800	9,700	5,600	8,800	8,700	5,000
0 ft	Lower (std UC) – f. dozer & r. stabilizer up	18,700	16,100	12,300	12,200	10,600	8,200	8,700	7,600	5,900	6,600	5,700	4,400	5,100	4,400	3,300	4,500	3,900	2,900
	Lower (std UC) – f. dozer & r. stabilizer down	*31,300	*31,300	21,300	*22,800	20,500	13,700	*17,600	14,300	9,800	*14,000	10,800	7,400	*10,800	8,400	5,700	*8,800	7,600	5,100
	Lower (std UC) – 2 sets stabilizers up	18,600	16,600	12,400	12,100	11,000	8,300	8,700	7,900	5,900	6,500	5,900	4,400	5,100	4,600	3,400	4,500	4,100	2,900
	Lower (std UC) – 2 sets stabilizers down	*31,300	*31,300	26,300	*22,800	21,000	16,600	17,300	14,700	11,700	12,900	11,100	8,900	10,100	8,700	6,900	*8,800	7,800	6,200
	MH – stabilizers up – solid tires	17,100	17,100	11,800	11,300	11,300	8,000	8,200	8,200	5,800	6,300	6,300	4,400	4,900	4,900	3,400	4,500	4,500	3,400
	MH – stabilizers down – solid tires	*22,400	*22,400	*22,400	*21,500	*21,500	19,300	*16,600	*16,600	13,700	*12,900	*12,900	10,400	*9,400	*9,400	8,300			
-5 ft	Lower (std UC) – f. stabilizer & r. dozer up	16,900	15,600	11,200	11,100	10,400	7,600	8,000	7,500	5,500	6,100	5,700	4,100	4,800	4,500	3,200			
	Lower (std UC) – f. stabilizer & r. dozer down	*22,400	*22,400	19,300	*21,500	*21,500	12,600	16,400	16,000	9,100	12,300	12,100	6,900	*9,400	*9,400	5,500			
	Lower (std UC) – f. dozer & r. stabilizer up	17,500	15,000	11,200	11,500	10,000	7,600	8,300	7,200	5,500	6,300	5,500	4,100	5,000	4,300	3,200			
	Lower (std UC) – f. dozer & r. stabilizer down	*22,400	*22,400	20,100	*21,500	19,700	13,000	*16,600	13,900	9,400	*12,900	10,500	7,100	*9,400	8,300	5,600			
	Lower (std UC) – 2 sets stabilizers up	17,400	15,500	11,400	11,400	10,300	7,700	8,300	7,500	5,600	6,300	5,700	4,200	5,000	4,500	3,300			
	Lower (std UC) – 2 sets stabilizers down	*22,400	*22,400	*22,400	*21,500	20,300	15,800	*16,600	14,300	11,300	12,600	10,800	8,600	*9,400	8,600	6,800			

\*Limited by hydraulic rather than tipping load.

Lift capacity ratings are based on ISO 10567:2007, they do not exceed 87% of hydraulic lifting capacity or 75% of tipping load. The load point is the center line of the bucket pivot mounting pin on the stick. The oscillating axle must be locked. Lifting capacities are based on the machine standing on a firm uniform supporting surface. For lifting capacity including bucket and/or quick coupler, the respective weight has to be subtracted from above values. The use of a work tool attachment point to handle/lift objects, could affect the machine lift performance.

Always refer to the appropriate Operation and Maintenance Manual for specific product information.

### Lift Capacities

All values are in kg, hydraulic cab riser, work tool: none, with counterweight (4100 kg), heavy lift on.

		Load point height	Load over front	Load over rear	Load over side	Load at maximum reach (sticknose/bucket pin)													
		<b>Boom</b> 6.8 m MH									<b>Stick</b> 4.9 m MH								
		4500 mm			6000 mm			7500 mm			9000 mm			10 500 mm			mm		
	Undercarriage configuration																		
12 000 mm	MH – stabilizers up – solid tires																*7800	*7800	5850
	MH – stabilizers down – solid tires																*7800	*7800	*7800
	Lower (std UC) – f. stabilizer & r. dozer up																7700	7250	5600
	Lower (std UC) – f. stabilizer & r. dozer down																*7800	*7800	*7800
	Lower (std UC) – f. dozer & r. stabilizer up																*7800	7000	5600
	Lower (std UC) – f. dozer & r. stabilizer down																*7800	*7800	*7800
	Lower (std UC) – 2 sets stabilizers up																*7800	7200	5650
	Lower (std UC) – 2 sets stabilizers down																*7800	*7800	*7800
10 500 mm	MH – stabilizers up – solid tires				6450	6450	4900	4400	4400	3300							4400	4400	3300
	MH – stabilizers down – solid tires				*9150	*9150	*9150	*6300	*6300	*6300							*6300	*6300	*6300
	Lower (std UC) – f. stabilizer & r. dozer up				6350	6000	4700	4300	4100	3150							4300	4100	3150
	Lower (std UC) – f. stabilizer & r. dozer down				*9150	*9150	7050	*6300	*6300	4800							*6300	*6300	4800
	Lower (std UC) – f. dozer & r. stabilizer up				6550	5800	4700	4450	3950	3150							4450	3950	3150
	Lower (std UC) – f. dozer & r. stabilizer down				*9150	*9150	7200	*6300	*6300	4900							*6300	*6300	4900
	Lower (std UC) – 2 sets stabilizers up				6500	6000	4750	4400	4050	3200							4400	4050	3200
	Lower (std UC) – 2 sets stabilizers down				*9150	*9150	8550	*6300	*6300	5800							*6300	*6300	5800
9000 mm	MH – stabilizers up – solid tires				6550	6550	5000	4550	4550	3450							3300	3300	2450
	MH – stabilizers down – solid tires				*9250	*9250	*8250	*8050	*8050	7000							*5700	*5700	5150
	Lower (std UC) – f. stabilizer & r. dozer up				6450	6100	4800	4450	4250	3300							3200	3050	2350
	Lower (std UC) – f. stabilizer & r. dozer down				*9250	*9250	7150	*8050	*8050	4950							*5700	*5700	3600
	Lower (std UC) – f. dozer & r. stabilizer up				6650	5900	4800	4600	4100	3300							3300	2950	2350
	Lower (std UC) – f. dozer & r. stabilizer down				*9250	*9250	7350	*8050	7100	5050							*5700	5200	3650
	Lower (std UC) – 2 sets stabilizers up				6600	6100	4850	4550	4200	3350							3300	3050	2350
	Lower (std UC) – 2 sets stabilizers down				*9250	*9250	8650	*8050	7300	5950							*5700	5350	4350
7500 mm	MH – stabilizers up – solid tires				6500	6500	4950	4550	4550	3450	3350	3350	2500				2750	2750	2000
	MH – stabilizers down – solid tires				*9300	*9300	*9300	*8000	*8000	7000	6350	6350	5150				5300	5300	4300
	Lower (std UC) – f. stabilizer & r. dozer up				6400	6050	4750	4400	4200	3300	3250	3100	2400				2650	2550	1900
	Lower (std UC) – f. stabilizer & r. dozer down				*9300	*9300	7100	*8000	*8000	4900	6000	5900	3600				5000	4900	3000
	Lower (std UC) – f. dozer & r. stabilizer up				6600	5850	4750	4550	4100	3300	3350	3000	2400				2750	2450	1900
	Lower (std UC) – f. dozer & r. stabilizer down				*9300	*9300	7300	*8000	7100	5050	6700	5200	3700				*5400	4300	3050
	Lower (std UC) – 2 sets stabilizers up				6550	6050	4800	4550	4200	3350	3350	3100	2400				2750	2500	1950
	Lower (std UC) – 2 sets stabilizers down				*9300	*9300	8600	*8000	7300	5950	6150	5350	4350				5100	4450	3600
6000 mm	MH – stabilizers up – solid tires				6300	6300	4800	4450	4450	3350	3300	3300	2450	2500	1850		2400	2400	1750
	MH – stabilizers down – solid tires				*9700	*9700	*9700	*9200	*8200	6900	6300	6300	5150	4900	4900	3950	4700	4700	3800
	Lower (std UC) – f. stabilizer & r. dozer up				6200	5900	4600	4300	4100	3200	3200	3050	2350	2450	2300	1750	2200	2200	1650
	Lower (std UC) – f. stabilizer & r. dozer down				*9700	*9700	6900	8100	7950	4800	5950	5850	3600	4600	4550	2750	4400	4350	2650
	Lower (std UC) – f. dozer & r. stabilizer up				6400	5700	4600	4450	4000	3200	3300	2950	2350	2550	2250	1750	2400	2150	1650
	Lower (std UC) – f. dozer & r. stabilizer down				*9700	*9700	7100	*8200	7000	4950	6650	5150	3650	5150	4000	2800	4950	3850	2700
	Lower (std UC) – 2 sets stabilizers up				6350	5850	4650	4450	4100	3250	3300	3050	2350	2500	2300	1750	2400	2200	1700
	Lower (std UC) – 2 sets stabilizers down				*9700	*9700	8400	*8200	7200	5850	6100	5300	4350	4750	4100	3350	4550	3950	3200
4500 mm	MH – stabilizers up – solid tires				9500	9500	7050	6050	6050	4500	4250	3200	3200	2400	2500	1800	2200	2200	1600
	MH – stabilizers down – solid tires				*13 100	*13 100	*13 100	*10 250	*10 250	9700	8350	8350	6700	6200	6200	5050	4850	4850	3550
	Lower (std UC) – f. stabilizer & r. dozer up				9450	8800	6750	5900	5600	4350	4150	3950	3050	3100	2950	2250	2400	2300	1700
	Lower (std UC) – f. stabilizer & r. dozer down				*13 100	*13 100	10 600	*10 250	*10 250	6600	7900	7750	4650	5850	5750	3500	4550	4500	2700
	Lower (std UC) – f. dozer & r. stabilizer up				9750	8550	6750	6100	5400	4350	4300	3800	3050	3200	2850	2250	2500	2200	1700
	Lower (std UC) – f. dozer & r. stabilizer down				*13 100	*13 100	10 950	*10 250	9850	6800	*8400	6800	4750	6550	5050	3550	5100	3950	2750
	Lower (std UC) – 2 sets stabilizers up				9650	8750	6800	6100	5600	4350	4300	3950	3100	3200	2950	2300	2500	2300	1750
	Lower (std UC) – 2 sets stabilizers down				*13 100	*13 100	*13 100	*10 250	10 150	8100	8100	7000	5650	6000	5200	4250	4700	4100	3300

\* Limited by hydraulic rather than tipping load.

(continued on next page)

Lift capacity ratings are based on ISO 10567:2007, they do not exceed 87% of hydraulic lifting capacity or 75% of tipping load. The load point is the center line of the bucket pivot mounting pin on the stick. The oscillating axle must be locked. Lifting capacities are based on the machine standing on a firm uniform supporting surface. For lifting capacity including bucket and/or quick coupler, the respective weight has to be subtracted from above values. The use of a work tool attachment point to handle/lift objects, could affect the machine lift performance.

Always refer to the appropriate Operation and Maintenance Manual for specific product information.

**Lift Capacities (continued)**

All values are in kg, hydraulic cab riser, work tool: none, with counterweight (4100 kg), heavy lift on.



**Undercarriage**

**Boom**  
6.8 m MH

**Stick**  
4.9 m MH

MH or Standard

Load point height	Undercarriage configuration	4500 mm			6000 mm			7500 mm			9000 mm			10 500 mm			mm			
		Load over front	Load over rear	Load over side	Load over front	Load over rear	Load over side	Load over front	Load over rear	Load over side	Load over front	Load over rear	Load over side	Load at maximum reach (sticknose/bucket pin)						
3000 mm	MH – stabilizers up – solid tires	8700	8700	6300	5650	5650	4150	4050	4050	3000	3100	3100	2250	2400	2400	1750	2100	2100	1500	11 470
	MH – stabilizers down – solid tires	*14 450	*14 450	*14 450	*10 800	*10 800	9250	8100	8100	6500	6100	6100	4900	4800	4800	3900	4150	4150	3400	
	Lower (std UC) – f. stabilizer & r. dozer up	8600	8000	6000	5550	5250	3950	3950	3750	2850	3000	2850	2150	2350	2250	1650	2000	1950	1400	
	Lower (std UC) – f. stabilizer & r. dozer down	*14 450	*14 450	9750	*10 800	*10 800	6200	7650	7500	4450	5750	5650	3350	4500	4450	2650	3900	3850	2300	
	Lower (std UC) – f. dozer & r. stabilizer up	8900	7750	6000	5700	5050	3950	4100	3600	2850	3100	2750	2150	2450	2150	1650	2100	1850	1400	
	Lower (std UC) – f. dozer & r. stabilizer down	*14 450	*14 450	10 050	*10 800	9400	6400	*8600	6550	4550	6400	4950	3450	5050	3900	2700	4400	3400	2350	
1500 mm	Lower (std UC) – 2 sets stabilizers up	8850	8000	6100	5700	5200	4000	4050	3750	2900	3100	2850	2150	2400	2200	1700	2100	1900	1450	11 520
	Lower (std UC) – 2 sets stabilizers down	*14 450	*14 450	12 350	*10 800	9700	7650	7900	6750	5450	5900	5100	4100	4650	4000	3250	4000	3500	2800	
	MH – stabilizers up – solid tires	7950	7950	5600	5250	5250	3800	3850	2800	2950	2950	2150	2350	2350	1700	2050	2050	1450		
	MH – stabilizers down – solid tires	*14 950	*14 950	14 250	*10 950	*10 950	8800	7850	7850	6250	5950	5950	4800	4700	4700	3800	4100	4100	3300	
	Lower (std UC) – f. stabilizer & r. dozer up	7800	7250	5300	5150	4850	3600	3750	3550	2650	2850	2750	2050	2250	2150	1600	1950	1900	1350	
	Lower (std UC) – f. stabilizer & r. dozer down	*14 950	*14 950	8900	10 750	10 400	5850	7400	7250	4250	5600	5500	3250	4450	4350	2600	3850	3800	2250	
0 mm	Lower (std UC) – f. dozer & r. stabilizer up	8100	7000	5300	5350	4650	3600	3900	3400	2650	3000	2600	2050	2350	2100	1600	2050	1800	1350	
	Lower (std UC) – f. dozer & r. stabilizer down	*14 950	14 700	9250	*10 950	8950	6000	8400	6350	4350	6300	4800	3350	4950	3800	2650	4300	3350	2300	
	Lower (std UC) – 2 sets stabilizers up	8050	7200	5350	5300	4850	3650	3850	3550	2700	2950	2700	2050	2350	2150	1600	2050	1850	1400	
	Lower (std UC) – 2 sets stabilizers down	*14 950	*14 950	11 450	*10 950	9250	7250	7650	6500	5200	5750	4950	4000	4550	3950	3200	3950	3450	2750	
	MH – stabilizers up – solid tires	7450	7450	5150	5000	5000	3550	3700	3700	2650	2850	2850	2050	2300	2300	1650				
	MH – stabilizers down – solid tires	*10 200	*10 200	*10 200	*10 450	*10 450	8450	7650	7650	6050	5850	5850	4650	4650	4650	3750				
-1500 mm	Lower (std UC) – f. stabilizer & r. dozer up	7300	6750	4850	4850	4550	3350	3550	3400	2500	2750	2650	1950	2200	2100	1550				
	Lower (std UC) – f. stabilizer & r. dozer down	*10 200	*10 200	8400	10 350	10 050	5550	7200	7050	4050	5500	5400	3150	4350	4300	2550				
	Lower (std UC) – f. dozer & r. stabilizer up	7600	6500	4850	5050	4400	3350	3700	3250	2500	2900	2500	1950	2300	2050	1550				
	Lower (std UC) – f. dozer & r. stabilizer down	*10 200	*10 200	8700	*10 450	8600	5700	*8150	6150	4150	6150	4700	3250	4900	3750	2600				
	Lower (std UC) – 2 sets stabilizers up	7550	6750	4950	5000	4550	3400	3700	3350	2550	2850	2600	1950	2300	2100	1550				
	Lower (std UC) – 2 sets stabilizers down	*10 200	*10 200	*10 200	*10 450	8900	6950	7400	6350	5050	5650	4850	3900	4500	3900	3100				

\*Limited by hydraulic rather than tipping load.

Lift capacity ratings are based on ISO 10567:2007, they do not exceed 87% of hydraulic lifting capacity or 75% of tipping load. The load point is the center line of the bucket pivot mounting pin on the stick. The oscillating axle must be locked. Lifting capacities are based on the machine standing on a firm uniform supporting surface. For lifting capacity including bucket and/or quick coupler, the respective weight has to be subtracted from above values. The use of a work tool attachment point to handle/lift objects, could affect the machine lift performance.

Always refer to the appropriate Operation and Maintenance Manual for specific product information.

### Lift Capacities

All values are in lb, hydraulic cab riser, work tool: none, with counterweight (9040 lb), heavy lift on.

		Load point height			Load over front			Load over rear			Load over side			Load at maximum reach (sticknose/bucket pin)					
<b>Undercarriage</b>		<b>Boom</b>									<b>Stick</b>								
MH or Standard		15 ft			20 ft			25 ft			30 ft			35 ft			ft		
	Undercarriage configuration																		
40 ft	MH – stabilizers up – solid tires	*19,000	*19,000	15,700													*18,000	*18,000	14,600
	MH – stabilizers down – solid tires	*19,000	*19,000	*19,000													*18,000	*18,000	*18,000
	Lower (std UC) – f. stabilizer & r. dozer up	*19,000	*19,000	15,100													*18,000	*18,000	14,100
	Lower (std UC) – f. stabilizer & r. dozer down	*19,000	*19,000	*19,000													*18,000	*18,000	*18,000
	Lower (std UC) – f. dozer & r. stabilizer up	*19,000	19,000	15,100													*18,000	17,600	14,100
	Lower (std UC) – f. dozer & r. stabilizer down	*19,000	*19,000	*19,000													*18,000	*18,000	*18,000
	Lower (std UC) – 2 sets stabilizers up	*19,000	*19,000	15,300													*18,000	*18,000	14,200
Lower (std UC) – 2 sets stabilizers down	*19,000	*19,000	*19,000													*18,000	*18,000	*18,000	
35 ft	MH – stabilizers up – solid tires				13,800	13,800	10,500										10,100	10,100	7,700
	MH – stabilizers down – solid tires				*19,500	*19,500	*19,500										*14,100	*14,100	*14,100
	Lower (std UC) – f. stabilizer & r. dozer up				13,500	12,800	10,100										9,900	9,400	7,200
	Lower (std UC) – f. stabilizer & r. dozer down				*19,500	*19,500	15,100										*14,100	*14,100	11,000
	Lower (std UC) – f. dozer & r. stabilizer up				14,000	12,400	10,100										10,200	9,100	7,200
	Lower (std UC) – f. dozer & r. stabilizer down				*19,500	*19,500	15,200										*14,100	*14,100	11,300
	Lower (std UC) – 2 sets stabilizers up				13,900	12,800	10,500										10,400	9,400	7,400
Lower (std UC) – 2 sets stabilizers down				*19,500	*19,500	18,300										*14,100	*14,100	13,400	
30 ft	MH – stabilizers up – solid tires				14,000	14,000	10,700	9,700	9,700	7,400							7,400	7,400	5,600
	MH – stabilizers down – solid tires				*20,200	*20,200	*20,200	*17,600	*17,600	15,000							*12,700	*12,700	11,600
	Lower (std UC) – f. stabilizer & r. dozer up				13,800	13,100	10,300	9,500	9,100	7,100							7,200	6,900	5,300
	Lower (std UC) – f. stabilizer & r. dozer down				*20,200	*20,200	15,300	*17,600	17,300	10,600							*12,700	*12,700	8,100
	Lower (std UC) – f. dozer & r. stabilizer up				14,200	12,700	10,300	9,800	8,800	7,100							7,500	6,600	5,300
	Lower (std UC) – f. dozer & r. stabilizer down				*20,200	*20,200	15,700	*17,600	15,200	10,800							*12,700	11,700	8,300
	Lower (std UC) – 2 sets stabilizers up				14,200	13,100	10,400	9,700	9,000	7,100							7,400	6,900	5,300
Lower (std UC) – 2 sets stabilizers down				*20,200	*20,200	18,600	*17,600	15,600	12,700							*12,700	12,000	9,800	
25 ft	MH – stabilizers up – solid tires				14,000	14,000	10,700	9,700	9,700	7,400	7,100	7,100	5,300				6,100	6,100	4,500
	MH – stabilizers down – solid tires				*20,300	*20,300	*20,300	*17,500	*17,500	15,100	13,600	13,600	11,100				11,800	11,800	9,600
	Lower (std UC) – f. stabilizer & r. dozer up				13,700	13,000	10,200	9,500	9,100	7,100	6,900	6,600	5,100				5,900	5,700	4,300
	Lower (std UC) – f. stabilizer & r. dozer down				*20,300	*20,300	15,300	*17,500	17,300	10,600	12,900	12,700	7,800				11,100	10,900	6,700
	Lower (std UC) – f. dozer & r. stabilizer up				14,200	12,600	10,200	9,800	8,800	7,100	7,200	6,400	5,100				6,100	5,400	4,300
	Lower (std UC) – f. dozer & r. stabilizer down				*20,300	*20,300	15,700	*17,500	15,200	10,800	14,400	11,200	7,900				*12,000	9,600	6,800
	Lower (std UC) – 2 sets stabilizers up				14,100	13,000	10,400	9,800	9,000	7,200	7,100	6,600	5,100				6,100	5,600	4,300
Lower (std UC) – 2 sets stabilizers down				*20,300	*20,300	18,500	*17,500	15,600	12,800	13,200	11,500	9,400				11,400	9,900	8,100	
20 ft	MH – stabilizers up – solid tires				13,600	13,600	10,300	9,500	9,500	7,200	7,100	7,100	5,300	5,400	5,400	3,900	5,300	5,300	3,900
	MH – stabilizers down – solid tires				*21,000	*21,000	*21,000	*17,800	*17,800	14,800	13,600	13,600	11,000	10,500	10,500	8,500	10,400	10,400	8,500
	Lower (std UC) – f. stabilizer & r. dozer up				13,400	12,700	9,900	9,300	8,900	6,900	6,900	6,600	5,000	5,200	5,000	3,700	5,200	4,900	3,700
	Lower (std UC) – f. stabilizer & r. dozer down				*21,000	*21,000	14,900	17,400	17,100	10,400	12,600	12,600	7,700	9,900	9,700	5,900	9,800	9,700	5,800
	Lower (std UC) – f. dozer & r. stabilizer up				13,800	12,300	9,900	9,600	8,600	6,900	7,100	6,300	5,000	5,400	4,800	3,700	5,400	4,700	3,700
	Lower (std UC) – f. dozer & r. stabilizer down				*21,000	*21,000	15,300	*17,800	15,000	10,600	14,300	11,100	7,900	11,000	8,600	6,000	11,000	8,500	6,000
	Lower (std UC) – 2 sets stabilizers up				13,700	12,600	10,000	9,600	8,800	7,000	7,100	6,500	5,100	5,400	4,900	3,800	5,300	4,900	3,700
Lower (std UC) – 2 sets stabilizers down				*21,000	*21,000	18,100	*17,800	15,400	12,500	13,200	11,400	9,300	10,100	8,800	7,200	10,100	8,800	7,100	
15 ft	MH – stabilizers up – solid tires	20,500	20,500	15,200	13,000	13,000	9,800	9,200	9,200	6,900	6,900	6,900	5,100	5,300	5,300	3,900	4,900	4,900	3,500
	MH – stabilizers down – solid tires	*28,400	*28,400	*28,400	*22,200	*22,200	20,800	18,000	18,000	14,500	13,400	13,400	10,800	10,400	10,400	8,500	9,600	9,600	7,800
	Lower (std UC) – f. stabilizer & r. dozer up	20,300	19,000	14,600	12,800	12,100	9,300	9,000	8,500	6,600	6,700	6,400	4,800	5,100	4,900	3,700	4,700	4,500	3,300
	Lower (std UC) – f. stabilizer & r. dozer down	*28,400	*28,400	22,800	*22,200	*22,200	14,300	17,000	16,700	10,000	12,600	12,400	7,500	9,800	9,700	5,800	9,000	8,900	5,300
	Lower (std UC) – f. dozer & r. stabilizer up	21,000	18,400	14,600	13,200	11,700	9,300	9,300	8,200	6,600	6,900	6,100	4,800	5,400	4,700	3,700	4,900	4,300	3,300
	Lower (std UC) – f. dozer & r. stabilizer down	*28,400	*28,400	23,500	*22,200	21,200	14,600	*18,300	14,600	10,300	14,100	10,900	7,700	11,000	8,500	6,000	10,100	7,800	5,500
	Lower (std UC) – 2 sets stabilizers up	20,800	18,900	14,700	13,100	12,000	9,400	9,200	8,500	6,600	6,900	6,400	4,900	5,300	4,900	3,700	4,900	4,500	3,400
Lower (std UC) – 2 sets stabilizers down	*28,400	*28,400	*28,400	*22,200	21,800	17,400	17,500	15,000	12,200	12,900	11,200	9,100	10,100	8,800	7,100	9,300	8,100	6,500	

\*Limited by hydraulic rather than tipping load.

(continued on next page)

Lift capacity ratings are based on ISO 10567:2007, they do not exceed 87% of hydraulic lifting capacity or 75% of tipping load. The load point is the center line of the bucket pivot mounting pin on the stick. The oscillating axle must be locked. Lifting capacities are based on the machine standing on a firm uniform supporting surface. For lifting capacity including bucket and/or quick coupler, the respective weight has to be subtracted from above values. The use of a work tool attachment point to handle/lift objects, could affect the machine lift performance.

Always refer to the appropriate Operation and Maintenance Manual for specific product information.

**Lift Capacities (continued)**

All values are in lb, hydraulic cab riser, work tool: none, with counterweight (9040 lb), heavy lift on.



**Undercarriage**

**Boom**  
22'4" MH

**Stick**  
16'1" MH

MH or Standard

Load point height	Undercarriage configuration	15 ft			20 ft			25 ft			30 ft			35 ft			ft		
		Load over front	Load over rear	Load over side	Load over front	Load over rear	Load over side	Load over front	Load over rear	Load over side	Load over front	Load over rear	Load over side	Load over front	Load over rear	Load over side			
10 ft	MH – stabilizers up – solid tires	18,800	18,800	13,600	12,200	12,200	9,000	8,800	8,800	6,500	6,600	6,600	4,900	5,200	5,200	3,800	4,600	4,600	3,300
	MH – stabilizers down – solid tires	*31,300	*31,300	*31,300	*23,400	*23,400	19,900	17,400	17,400	14,000	13,100	13,100	10,600	10,300	10,300	8,300	9,200	9,200	7,500
	Lower (std UC) – f. stabilizer & r. dozer up	18,800	17,300	13,000	11,900	11,300	8,600	8,500	8,100	6,100	6,400	6,100	4,600	5,000	4,800	3,600	4,400	4,300	3,100
	Lower (std UC) – f. stabilizer & r. dozer down	*31,300	*31,300	21,000	*23,400	23,300	13,400	16,500	16,100	9,600	12,300	12,100	7,300	9,700	9,500	5,700	8,600	8,500	5,100
	Lower (std UC) – f. dozer & r. stabilizer up	19,200	16,700	13,000	12,400	10,900	8,600	8,800	7,800	6,100	6,700	5,900	4,600	5,200	4,600	3,600	4,600	4,100	3,100
	Lower (std UC) – f. dozer & r. stabilizer down	*31,300	*31,300	21,700	*23,400	20,200	13,800	18,600	14,100	9,800	13,800	10,600	7,400	10,800	8,400	5,800	9,700	7,500	5,200
5 ft	Lower (std UC) – 2 sets stabilizers up	19,100	17,200	13,200	12,300	11,200	8,700	8,800	8,100	6,200	6,600	6,100	4,700	5,200	4,800	3,600	4,600	4,200	3,200
	Lower (std UC) – 2 sets stabilizers down	*31,300	*31,300	26,500	*23,400	20,800	16,500	16,900	14,500	11,700	12,700	11,000	8,900	10,000	8,600	7,000	8,900	7,700	6,200
	MH – stabilizers up – solid tires	17,100	17,100	12,100	11,400	11,400	8,200	8,300	8,300	6,100	6,400	6,400	4,600	5,100	5,100	3,600	4,500	4,500	3,200
	MH – stabilizers down – solid tires	*32,400	*32,400	30,500	*23,800	*23,800	18,900	16,900	16,900	13,500	12,800	12,800	10,300	10,200	10,200	8,200	9,100	9,100	7,300
	Lower (std UC) – f. stabilizer & r. dozer up	16,800	15,700	11,500	11,100	10,500	7,800	8,100	7,700	5,700	6,200	5,900	4,400	4,900	4,700	3,400	4,300	4,200	3,000
	Lower (std UC) – f. stabilizer & r. dozer down	*32,400	*32,400	19,200	23,000	22,300	12,600	16,000	15,600	9,100	12,000	11,800	7,000	9,500	9,400	5,600	8,500	8,400	5,000
0 ft	Lower (std UC) – f. dozer & r. stabilizer up	17,500	15,100	11,500	11,500	10,100	7,800	8,400	7,400	5,700	6,400	5,600	4,400	5,100	4,500	3,400	4,500	4,000	3,000
	Lower (std UC) – f. dozer & r. stabilizer down	*32,400	31,500	19,900	*23,800	19,300	12,900	18,000	13,600	9,400	13,500	10,400	7,200	10,700	8,200	5,700	9,500	7,300	5,100
	Lower (std UC) – 2 sets stabilizers up	17,300	15,600	11,600	11,400	10,400	7,900	8,300	7,600	5,800	6,400	5,900	4,400	5,100	4,600	3,500	4,500	4,100	3,100
	Lower (std UC) – 2 sets stabilizers down	*32,400	*32,400	24,600	23,600	19,900	15,600	16,400	14,000	11,200	12,400	10,700	8,600	9,800	8,500	6,800	8,700	7,600	6,100
	MH – stabilizers up – solid tires	16,000	16,000	11,100	10,800	10,800	7,700	7,900	7,900	5,700	6,200	6,200	4,400	5,000	5,000	3,500	4,500	4,500	3,200
	MH – stabilizers down – solid tires	*23,900	*23,900	*23,900	*22,700	*22,700	18,200	16,500	16,500	13,100	12,600	12,600	10,100	10,000	10,000	8,100	9,100	9,100	7,300
-5 ft	Lower (std UC) – f. stabilizer & r. dozer up	15,700	14,600	10,500	10,500	9,900	7,200	7,700	7,300	5,400	6,000	5,700	4,200	4,800	4,600	3,300	4,300	4,200	3,000
	Lower (std UC) – f. stabilizer & r. dozer down	*23,900	*23,900	18,100	22,200	21,600	11,900	15,500	15,200	8,700	11,800	11,600	6,800	9,400	9,300	5,500	8,600	8,500	5,100
	Lower (std UC) – f. dozer & r. stabilizer up	16,400	14,000	10,500	10,900	9,500	7,200	8,000	7,000	5,400	6,200	5,400	4,200	5,000	4,400	3,300	4,300	4,200	3,000
	Lower (std UC) – f. dozer & r. stabilizer down	*23,900	*23,900	18,700	*22,700	18,500	12,300	17,600	13,200	9,000	13,300	10,100	7,000	*10,500	8,100	5,600	9,500	7,300	5,100
	Lower (std UC) – 2 sets stabilizers up	16,200	14,500	10,600	10,800	9,800	7,300	8,000	7,300	5,500	6,200	5,600	4,200	5,000	4,500	3,400	4,500	4,100	3,100
	Lower (std UC) – 2 sets stabilizers down	*23,900	*23,900	23,300	*22,700	19,100	15,000	16,000	13,600	10,800	12,100	10,500	8,400	9,700	8,400	6,700	8,700	7,600	6,100

\*Limited by hydraulic rather than tipping load.

Lift capacity ratings are based on ISO 10567:2007, they do not exceed 87% of hydraulic lifting capacity or 75% of tipping load. The load point is the center line of the bucket pivot mounting pin on the stick. The oscillating axle must be locked. Lifting capacities are based on the machine standing on a firm uniform supporting surface. For lifting capacity including bucket and/or quick coupler, the respective weight has to be subtracted from above values. The use of a work tool attachment point to handle/lift objects, could affect the machine lift performance.

Always refer to the appropriate Operation and Maintenance Manual for specific product information.



### Lift Capacities

All values are in kg, hydraulic cab riser, work tool: none, with counterweight (5200 kg), heavy lift on.



Undercarriage MH or Standard		Boom 6.8 m MH									Stick 4.9 m MH											
		4500 mm			6000 mm			7500 mm			9000 mm			10 500 mm			mm					
Load point height	Undercarriage configuration	Load over front	Load over rear	Load over side	Load over front	Load over rear	Load over side	Load over front	Load over rear	Load over side	Load over front	Load over rear	Load over side	Load at maximum reach (sticknose/bucket pin)	mm							
		12 000 mm	MH – stabilizers up – solid tires																*7800	*7800	6550	
MH – stabilizers down – solid tires																	*7800	*7800	*7800			
Lower (std UC) – f. stabilizer & r. dozer up																	*7800	*7800	6300			
Lower (std UC) – f. stabilizer & r. dozer down																	*7800	*7800	*7800			
Lower (std UC) – f. dozer & r. stabilizer up																	*7800	*7800	6300			
Lower (std UC) – f. dozer & r. stabilizer down																	*7800	*7800	*7800			
Lower (std UC) – 2 sets stabilizers up																	*7800	*7800	6400			
Lower (std UC) – 2 sets stabilizers down																*7800	*7800	*7800				
10 500 mm	MH – stabilizers up – solid tires				7150	7150	5500	4900	4900	3800							4900	4900	3750			
	MH – stabilizers down – solid tires				*9150	*9150	*9150	*6300	*6300	*6300							*6300	*6300	*6300			
	Lower (std UC) – f. stabilizer & r. dozer up				7050	6650	5300	4850	4600	3600							4850	4600	3600			
	Lower (std UC) – f. stabilizer & r. dozer down				*9150	*9150	7800	*6300	*6300	5350							*6300	*6300	5350			
	Lower (std UC) – f. dozer & r. stabilizer up				7250	6500	5300	4950	4450	3600							4950	4450	3600			
	Lower (std UC) – f. dozer & r. stabilizer down				*9150	*9150	8000	*6300	*6300	5450							*6300	*6300	5450			
	Lower (std UC) – 2 sets stabilizers up				7200	6650	5350	4950	4600	3650							4950	4600	3650			
Lower (std UC) – 2 sets stabilizers down				*9150	*9150	*9150	*6300	*6300	*6300							*6300	*6300	*6300				
9000 mm	MH – stabilizers up – solid tires				7250	7250	5600	5050	5050	3900							3700	3700	2850			
	MH – stabilizers down – solid tires				*9250	*9250	*9250	*8050	*8050	7700							*5700	*5700	5650			
	Lower (std UC) – f. stabilizer & r. dozer up				7150	6750	5400	4950	4750	3750							3650	3450	2750			
	Lower (std UC) – f. stabilizer & r. dozer down				*9250	*9250	7900	*8050	*8050	5500							*5700	*5700	4050			
	Lower (std UC) – f. dozer & r. stabilizer up				7350	6600	5400	5100	4600	3750							3750	3350	2750			
	Lower (std UC) – f. dozer & r. stabilizer down				*9250	*9250	8100	*8050	7800	5600							*5700	*5700	4100			
	Lower (std UC) – 2 sets stabilizers up				7300	6750	5450	5100	4700	3800							3700	3450	2750			
Lower (std UC) – 2 sets stabilizers down				*9250	*9250	*9250	*8050	8000	6550							*5700	*5700	4850				
7500 mm	MH – stabilizers up – solid tires				7200	7200	5550	5050	5050	3900	3750	3750	2850				3100	3100	2350			
	MH – stabilizers down – solid tires				*9300	*9300	*9300	*8000	*8000	7700	6950	6950	5700				*5400	*5400	4750			
	Lower (std UC) – f. stabilizer & r. dozer up				7100	6700	5350	4950	4700	3750	3650	3500	2750				3000	2900	2250			
	Lower (std UC) – f. stabilizer & r. dozer down				*9300	*9300	7850	*8000	*8000	5500	6600	6500	4050				*5400	5400	3350			
	Lower (std UC) – f. dozer & r. stabilizer up				7300	6550	5350	5100	4600	3750	3800	3400	2750				3150	2800	2250			
	Lower (std UC) – f. dozer & r. stabilizer down				*9300	*9300	8050	*8000	7800	5600	*7000	5750	4150				*5400	4800	3450			
	Lower (std UC) – 2 sets stabilizers up				7250	6700	5400	5100	4700	3800	3750	3500	2750				3100	2850	2250			
Lower (std UC) – 2 sets stabilizers down				*9300	*9300	*9300	*8000	8000	6550	6900	5900	4650				*5400	4950	4650				
6000 mm	MH – stabilizers up – solid tires				7000	7000	5400	4950	4950	3800	3700	3700	2850	2850	2150		2750	2750	2050			
	MH – stabilizers down – solid tires				*9700	*9700	*9700	*8200	*8200	7550	6900	6900	5650	5400	5400		5200	5200	4250			
	Lower (std UC) – f. stabilizer & r. dozer up				6950	6550	5200	4850	4650	3650	3600	3450	2700	2800	2650	2050	2650	2550	1950			
	Lower (std UC) – f. stabilizer & r. dozer down				*9700	*9700	7650	*8200	*8200	5400	6550	6450	4000	5100	5000	3100	4900	4800	3000			
	Lower (std UC) – f. dozer & r. stabilizer up				7100	6350	5200	5000	4500	3650	3750	3350	2700	2900	2550	2050	2750	2450	1950			
	Lower (std UC) – f. dozer & r. stabilizer down				*9700	*9700	7850	*8200	7700	5500	*7050	5700	4100	5650	4450	3200	*5300	4250	3050			
	Lower (std UC) – 2 sets stabilizers up				7100	6550	5250	5000	4600	3700	3700	3450	2750	2850	2650	2050	2750	2550	2000			
Lower (std UC) – 2 sets stabilizers down				*9700	*9700	9250	*8200	7900	6450	6750	5850	4800	5200	4550	3750	5000	4400	3600				
4500 mm	MH – stabilizers up – solid tires				10 550	10 550	7900	6700	6700	5100	4800	4800	3650	3600	3600	2750	2850	2100	2550	1900		
	MH – stabilizers down – solid tires				*13 100	*13 100	*13 100	*10 250	*10 250	*10 250	*8400	*8400	7400	6800	6800	5550	5350	4350	4800	3950		
	Lower (std UC) – f. stabilizer & r. dozer up				10 500	9800	7600	6650	6250	4900	4700	4450	3500	3550	3350	2600	2750	2050	2450	1850		
	Lower (std UC) – f. stabilizer & r. dozer down				*13 100	*13 100	11 700	*10 250	*10 250	7350	*8400	*8400	5200	6450	6350	3950	5050	3100	4550	4500	2750	
	Lower (std UC) – f. dozer & r. stabilizer up				10 800	9500	7600	6800	6100	4900	4850	4300	3500	3650	3250	2600	2850	2550	2000	2550	1800	
	Lower (std UC) – f. dozer & r. stabilizer down				*13 100	*13 100	12 100	*10 250	*10 250	7550	*8400	7500	5350	*7100	5600	4000	5600	4400	3150	5050	3950	2800
	Lower (std UC) – 2 sets stabilizers up				10 750	9750	7650	6800	6250	4950	4800	4450	3550	3650	3350	2650	2850	2600	2050	2550	1800	
Lower (std UC) – 2 sets stabilizers down				*13 100	*13 100	*13 100	*10 250	*10 250	8950	*8400	7700	6250	6650	5750	4750	5200	4550	3700	4650	4050	3350	

\* Limited by hydraulic rather than tipping load.

(continued on next page)

Lift capacity ratings are based on ISO 10567:2007, they do not exceed 87% of hydraulic lifting capacity or 75% of tipping load. The load point is the center line of the bucket pivot mounting pin on the stick. The oscillating axle must be locked. Lifting capacities are based on the machine standing on a firm uniform supporting surface. For lifting capacity including bucket and/or quick coupler, the respective weight has to be subtracted from above values. The use of a work tool attachment point to handle/lift objects, could affect the machine lift performance.

Always refer to the appropriate Operation and Maintenance Manual for specific product information.

**Lift Capacities (continued)**

All values are in kg, hydraulic cab riser, work tool: none, with counterweight (5200 kg), heavy lift on.



**Undercarriage**  
 MH or Standard

**Boom**  
 6.8 m MH

**Stick**  
 4.9 m MH

Stick height	Undercarriage configuration	4500 mm			6000 mm			7500 mm			9000 mm			10 500 mm			mm		
		Load point height	Load over front	Load over rear	Load point height	Load over front	Load over rear	Load point height	Load over front	Load over rear	Load point height	Load over front	Load over rear	Load point height	Load over front	Load over rear			
3000 mm	MH – stabilizers up – solid tires	9750	9750	7150	6350	6350	4750	4600	4600	3450	3500	3500	2650	2750	2050	2400	2400	1800	
	MH – stabilizers down – solid tires	*14 450	*14 450	*14 450	*10 800	*10 800	10 150	*8600	*8600	7150	6700	6700	5450	5300	5300	4300	4600	4600	3750
	Lower (std UC) – f. stabilizer & r. dozer up	9650	9000	6850	6250	5900	4550	4550	4250	3300	3400	3250	2500	2700	2550	1950	2350	2250	1700
	Lower (std UC) – f. stabilizer & r. dozer down	*14 450	*14 450	10 850	*10 800	*10 800	6950	8450	8250	5000	6350	6200	3800	5000	4900	3000	4350	4300	2650
	Lower (std UC) – f. dozer & r. stabilizer up	9950	8700	6850	6450	5700	4550	4650	4100	3300	3550	3150	2500	2800	2500	1950	2450	2150	1700
	Lower (std UC) – f. dozer & r. stabilizer down	*14 450	*14 450	11 200	*10 800	10 400	7150	*8600	7250	5100	7050	5500	3900	5550	4350	3100	4850	3800	2700
1500 mm	Lower (std UC) – 2 sets stabilizers up	9900	8950	6950	6400	5850	4600	4600	3350	3500	3250	2550	2800	2550	2000	2400	2200	1700	
	Lower (std UC) – 2 sets stabilizers down	*14 450	*14 450	13 650	*10 800	10 650	8500	*8600	7450	6050	6500	5650	4600	5100	4450	3650	4450	3900	3200
	MH – stabilizers up – solid tires	8950	8950	6450	5950	5950	4400	4350	3250	3400	3400	2500	2700	2700	2000	2350	2350	1750	
	MH – stabilizers down – solid tires	*14 950	*14 950	*14 950	*10 950	*10 950	9750	*8600	*8600	6950	6550	6550	5300	5200	5200	4250	*4400	*4400	3700
	Lower (std UC) – f. stabilizer & r. dozer up	8850	8250	6150	5850	5500	4200	4300	4050	3100	3300	3150	2400	2650	2500	1900	2300	2200	1650
	Lower (std UC) – f. stabilizer & r. dozer down	*14 950	*14 950	10 000	*10 950	*10 950	6550	8200	8000	4800	6200	6100	3700	4900	4850	2950	4300	4250	2650
0 mm	Lower (std UC) – f. dozer & r. stabilizer up	9150	7950	6150	6050	5350	4200	4400	3900	3100	3400	3050	2400	2750	2400	1900	2400	2100	1650
	Lower (std UC) – f. dozer & r. stabilizer down	*14 950	*14 950	10 350	*10 950	9950	6750	*8600	7050	4900	6900	5350	3800	5500	4250	3050	*4400	3750	2650
	Lower (std UC) – 2 sets stabilizers up	9100	8200	6200	6000	5500	4250	4400	4050	3150	3400	3100	2450	2700	2500	1950	2350	2200	1650
	Lower (std UC) – 2 sets stabilizers down	*14 950	*14 950	12 750	*10 950	10 200	8100	8400	7200	5850	6350	5500	4500	5050	4400	3600	*4400	3850	3150
	MH – stabilizers up – solid tires	8450	8450	6000	5650	5650	4150	4200	3100	3300	3300	2400	2650	2650	1950				
	MH – stabilizers down – solid tires	*10 200	*10 200	*10 200	*10 450	*10 450	9400	*8150	*8150	6750	6450	6450	5200	*4950	*4950	4200			
-1500 mm	Lower (std UC) – f. stabilizer & r. dozer up	8350	7750	5700	5550	5250	3950	4100	3900	2950	3200	3050	2300	2600	2450	1850			
	Lower (std UC) – f. stabilizer & r. dozer down	*10 200	*10 200	9500	*10 450	*10 450	6250	8000	7800	4600	6100	5950	3600	4850	4800	2900			
	Lower (std UC) – f. dozer & r. stabilizer up	8650	7450	5700	5750	5050	3950	4250	3750	2950	3300	2950	2300	2700	2350	1850			
	Lower (std UC) – f. dozer & r. stabilizer down	*10 200	*10 200	9850	*10 450	9600	6450	*8150	6850	4750	*6450	5250	3700	*4950	4200	2950			
	Lower (std UC) – 2 sets stabilizers up	8600	7700	5750	5750	5200	4000	4200	3850	3000	3300	3000	2350	2650	2450	1900			
	Lower (std UC) – 2 sets stabilizers down	*10 200	*10 200	*10 200	*10 450	9850	7800	*8150	7050	5850	6250	5400	4350	*4950	4350	3550			
	MH – stabilizers up – solid tires				5500	5500	4000	4100	4100	3000									
	MH – stabilizers down – solid tires				*9050	*9050	*9050	*7150	*7150	6600									
	Lower (std UC) – f. stabilizer & r. dozer up				5400	5100	3800	4000	3800	2850									
	Lower (std UC) – f. stabilizer & r. dozer down				*9050	*9050	6100	*7150	*7150	4500									
	Lower (std UC) – f. dozer & r. stabilizer up				5600	4900	3800	4150	3650	2850									
	Lower (std UC) – f. dozer & r. stabilizer down				*9050	*9050	6300	*7150	6700	4600									
	Lower (std UC) – 2 sets stabilizers up				5550	5050	3850	4100	3750	2900									
	Lower (std UC) – 2 sets stabilizers down				*9050	*9050	7600	*7150	6900	5550									

\*Limited by hydraulic rather than tipping load.

Lift capacity ratings are based on ISO 10567:2007, they do not exceed 87% of hydraulic lifting capacity or 75% of tipping load. The load point is the center line of the bucket pivot mounting pin on the stick. The oscillating axle must be locked. Lifting capacities are based on the machine standing on a firm uniform supporting surface. For lifting capacity including bucket and/or quick coupler, the respective weight has to be subtracted from above values. The use of a work tool attachment point to handle/lift objects, could affect the machine lift performance.

Always refer to the appropriate Operation and Maintenance Manual for specific product information.

### Lift Capacities

All values are in lb, hydraulic cab riser, work tool: none, with counterweight (11,470 lb), heavy lift on.

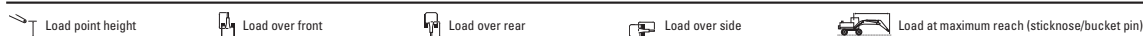

#### Undercarriage

#### Boom

#### Stick

MH or Standard

22'4" MH

16'1" MH

Load point height	Undercarriage configuration	15 ft			20 ft			25 ft			30 ft			35 ft			ft			
		Load over front	Load over rear	Load over side	Load over front	Load over rear	Load over side	Load over front	Load over rear	Load over side	Load over front	Load over rear	Load over side	Load over front	Load over rear	Load over side				
40 ft	MH – stabilizers up – solid tires	*19,000	*19,000	17,500														*18,000	*18,000	16,400
	MH – stabilizers down – solid tires	*19,000	*19,000	*19,000														*18,000	*18,000	*18,000
	Lower (std UC) – f. stabilizer & r. dozer up	*19,000	*19,000	16,900														*18,000	*18,000	15,800
	Lower (std UC) – f. stabilizer & r. dozer down	*19,000	*19,000	*19,000														*18,000	*18,000	*18,000
	Lower (std UC) – f. dozer & r. stabilizer up	*19,000	*19,000	16,900														*18,000	*18,000	15,800
	Lower (std UC) – f. dozer & r. stabilizer down	*19,000	*19,000	*19,000														*18,000	*18,000	*18,000
	Lower (std UC) – 2 sets stabilizers up	*19,000	*19,000	17,100														*18,000	*18,000	15,900
Lower (std UC) – 2 sets stabilizers down	*19,000	*19,000	*19,000														*18,000	*18,000	*18,000	
35 ft	MH – stabilizers up – solid tires				15,300	15,300	11,800											11,300	11,300	8,700
	MH – stabilizers down – solid tires				*19,500	*19,500	*19,500											*14,100	*14,100	*14,100
	Lower (std UC) – f. stabilizer & r. dozer up				15,100	14,300	11,300											11,100	10,600	8,300
	Lower (std UC) – f. stabilizer & r. dozer down				*19,500	*19,500	16,700											*14,100	*14,100	12,300
	Lower (std UC) – f. dozer & r. stabilizer up				15,500	13,900	11,300											11,400	10,200	8,300
	Lower (std UC) – f. dozer & r. stabilizer down				*19,500	*19,500	17,100											*14,100	*14,100	12,600
	Lower (std UC) – 2 sets stabilizers up				15,400	14,200	11,400											11,100	10,500	8,400
Lower (std UC) – 2 sets stabilizers down				*19,500	*19,500	*19,500											*14,100	*14,100	*14,100	
30 ft	MH – stabilizers up – solid tires				15,500	15,500	12,000	10,800	10,800	8,400								8,400	8,400	6,400
	MH – stabilizers down – solid tires				*20,200	*20,200	*20,200	*17,600	*17,600	16,500								*12,700	*12,700	*12,700
	Lower (std UC) – f. stabilizer & r. dozer up				15,300	14,500	11,600	10,600	10,100	8,000								8,200	7,800	6,100
	Lower (std UC) – f. stabilizer & r. dozer down				*20,200	*20,200	16,900	*17,600	*17,600	11,800								*12,700	*12,700	9,100
	Lower (std UC) – f. dozer & r. stabilizer up				15,800	14,100	11,600	11,000	9,800	8,000								8,400	7,500	6,100
	Lower (std UC) – f. dozer & r. stabilizer down				*20,200	*20,200	17,400	*17,600	16,700	12,000								*12,700	*12,700	9,300
	Lower (std UC) – 2 sets stabilizers up				15,700	14,500	11,700	10,900	10,100	8,100								8,400	7,800	6,200
Lower (std UC) – 2 sets stabilizers down				*20,200	*20,200	*20,200	*17,600	17,100	14,100								*12,700	*12,700	10,900	
25 ft	MH – stabilizers up – solid tires				15,500	15,500	11,900	10,900	10,900	8,400	8,000	8,000	6,100					6,900	6,900	5,200
	MH – stabilizers down – solid tires				*20,300	*20,300	*20,300	*17,500	*17,500	16,500	14,900	14,900	12,200					*12,000	*12,000	10,600
	Lower (std UC) – f. stabilizer & r. dozer up				15,300	14,500	11,500	10,700	10,200	8,100	7,900	7,500	5,900					6,700	6,400	5,000
	Lower (std UC) – f. stabilizer & r. dozer down				*20,300	*20,300	16,900	*17,500	*17,500	11,800	14,200	13,900	8,700					*12,000	*12,000	7,500
	Lower (std UC) – f. dozer & r. stabilizer up				15,700	14,100	11,500	11,000	9,800	8,100	8,100	7,300	5,900					7,000	6,200	5,000
	Lower (std UC) – f. dozer & r. stabilizer down				*20,300	*20,300	17,300	*17,500	16,700	12,100	*15,300	12,400	8,900					*12,000	10,700	7,700
	Lower (std UC) – 2 sets stabilizers up				15,600	14,400	11,600	10,800	10,100	8,100	8,100	7,500	5,900					6,900	6,400	5,100
Lower (std UC) – 2 sets stabilizers down				*20,300	*20,300	20,300	*17,500	17,200	14,100	14,500	12,700	10,400					*12,000	11,000	9,900	
20 ft	MH – stabilizers up – solid tires				15,100	15,100	11,600	10,700	10,700	8,200	8,000	8,000	6,100	6,100	4,600			6,100	6,100	4,600
	MH – stabilizers down – solid tires				*21,000	*21,000	*21,000	*17,800	*17,800	16,300	14,900	14,900	12,200	11,500	11,500	9,500		11,500	11,500	9,400
	Lower (std UC) – f. stabilizer & r. dozer up				14,900	14,100	11,200	10,500	10,000	7,900	7,900	7,400	5,800	6,000	4,400			5,900	5,700	4,300
	Lower (std UC) – f. stabilizer & r. dozer down				*21,000	*21,000	16,500	*17,800	*17,800	11,600	14,100	13,900	8,700	10,900	10,800	6,700		10,900	10,700	6,600
	Lower (std UC) – f. dozer & r. stabilizer up				15,300	13,700	11,200	10,800	9,700	7,900	8,000	7,200	5,800	6,200	5,500	4,400		6,100	5,500	4,300
	Lower (std UC) – f. dozer & r. stabilizer down				*21,000	*21,000	16,900	*17,800	16,500	11,900	*15,300	12,300	8,900	*12,100	11,900	6,800		11,700	9,500	6,800
	Lower (std UC) – 2 sets stabilizers up				15,300	14,100	11,300	10,700	9,900	7,900	8,000	7,400	5,900	6,100	5,700	4,400		6,100	5,600	4,400
Lower (std UC) – 2 sets stabilizers down				*21,000	*21,000	19,900	*17,800	16,900	13,900	14,500	12,600	10,400	11,200	9,800	8,000		11,100	9,700	8,000	
15 ft	MH – stabilizers up – solid tires	22,700	22,700	17,000	14,500	14,500	11,000	10,300	10,300	7,900	7,800	7,800	5,900	6,100	6,100	4,600		5,600	5,600	4,200
	MH – stabilizers down – solid tires	*28,400	*28,400	*28,400	*22,200	*22,200	*22,200	*18,300	*18,300	15,900	14,700	14,700	12,000	11,500	11,500	9,400		10,600	10,600	8,700
	Lower (std UC) – f. stabilizer & r. dozer up	22,600	21,100	16,400	14,300	13,500	10,600	10,100	9,600	7,500	7,600	7,300	5,600	5,900	5,700	4,300		5,400	5,200	4,000
	Lower (std UC) – f. stabilizer & r. dozer down	*28,400	*28,400	25,200	*22,200	*22,200	15,900	18,300	*18,300	11,200	13,900	13,700	8,500	10,900	10,700	6,600		10,000	9,900	6,100
	Lower (std UC) – f. dozer & r. stabilizer up	23,200	20,500	16,400	14,700	13,100	10,600	10,400	9,300	7,500	7,900	7,000	5,600	6,100	5,400	4,300		5,600	5,000	4,000
	Lower (std UC) – f. dozer & r. stabilizer down	*28,400	*28,400	26,000	*22,200	*22,200	16,300	*18,300	16,100	11,500	*15,400	12,100	8,700	12,100	9,500	6,800		11,200	8,800	6,200
	Lower (std UC) – 2 sets stabilizers up	23,100	21,000	16,600	14,600	13,500	10,700	10,400	9,600	7,600	7,800	7,200	5,700	6,100	5,600	4,400		5,600	5,200	4,000
Lower (std UC) – 2 sets stabilizers down	*28,400	*28,400	*28,400	*22,200	*22,200	19,200	*18,300	16,600	13,500	14,300	12,400	10,200	11,200	9,700	8,000		10,300	9,000	7,400	

\*Limited by hydraulic rather than tipping load.

(continued on next page)

Lift capacity ratings are based on ISO 10567:2007, they do not exceed 87% of hydraulic lifting capacity or 75% of tipping load. The load point is the center line of the bucket pivot mounting pin on the stick. The oscillating axle must be locked. Lifting capacities are based on the machine standing on a firm uniform supporting surface. For lifting capacity including bucket and/or quick coupler, the respective weight has to be subtracted from above values. The use of a work tool attachment point to handle/lift objects, could affect the machine lift performance.

Always refer to the appropriate Operation and Maintenance Manual for specific product information.

**Lift Capacities (continued)**

All values are in lb, hydraulic cab riser, work tool: none, with counterweight (11,470 lb), heavy lift on.



**Undercarriage**  
 MH or Standard

**Boom**  
 22'4" MH

**Stick**  
 16'1" MH

Load point height	Undercarriage configuration	15 ft			20 ft			25 ft			30 ft			35 ft			ft		
		Load over front	Load over rear	Load over side	Load over front	Load over rear	Load over side	Load over front	Load over rear	Load over side	Load over front	Load over rear	Load over side	Load over front	Load over rear	Load over side	Load at maximum reach (sticknose/bucket pin)	ft	
10 ft	MH – stabilizers up – solid tires	21,000	21,000	15,500	13,700	13,700	10,300	9900	9900	7500	7500	7500	5700	6000	6000	4400	5300	5300	3900
	MH – stabilizers down – solid tires	*31,300	*31,300	*31,300	*23,400	*23,400	21,900	*18,700	*18,700	15,400	14,400	14,400	11,700	11,400	11,400	9300	10,200	10,200	8300
	Lower (std UC) – f. stabilizer & r. dozer up	20,900	19,400	14,800	13,500	12,700	9900	9700	9200	7100	7400	7000	5400	5800	5500	4200	5200	4900	3700
	Lower (std UC) – f. stabilizer & r. dozer down	*31,300	*31,300	23,400	*23,400	*23,400	15,000	18,200	17,800	10,800	13,600	13,400	8200	10,700	10,600	6500	9600	9500	5800
	Lower (std UC) – f. dozer & r. stabilizer up	21,500	18,800	14,800	13,900	12,300	9900	10,000	8900	7100	7600	6800	5400	6000	5300	4200	5400	4700	3700
	Lower (std UC) – f. dozer & r. stabilizer down	*31,300	*31,300	24,200	*23,400	22,300	15,400	*18,700	15,600	11,000	15,200	11,800	8400	12,000	9300	6700	10,700	8400	5900
5 ft	Lower (std UC) – 2 sets stabilizers up	21,400	19,300	15,000	13,800	12,700	10,000	9900	9200	7200	7600	7000	5500	6000	5500	4300	5300	4900	3800
	Lower (std UC) – 2 sets stabilizers down	*31,300	*31,300	29,300	*23,400	22,900	18,300	18,600	16,100	13,000	14,000	12,100	9900	11,000	9600	7900	9900	8600	7000
	MH – stabilizers up – solid tires	19,300	19,300	13,900	12,900	12,900	9500	9400	9400	7000	7300	7300	5400	5800	5800	4300	5200	5200	3800
	MH – stabilizers down – solid tires	*32,400	*32,400	*32,400	*23,800	*23,800	20,900	18,600	18,600	14,900	14,100	14,100	11,400	11,200	11,200	9100	*9700	*9700	8200
	Lower (std UC) – f. stabilizer & r. dozer up	19,100	17,800	13,300	12,600	11,900	9100	9200	8800	6700	7100	6800	5200	5700	5400	4100	5100	4800	3600
	Lower (std UC) – f. stabilizer & r. dozer down	*32,400	*32,400	21,600	*23,800	*23,800	14,200	17,700	17,200	10,300	13,300	13,100	8000	10,600	10,400	6400	9500	9300	5700
0 ft	Lower (std UC) – f. dozer & r. stabilizer up	19,700	17,200	13,300	13,100	11,500	9100	9500	8400	6700	7400	6500	5200	5900	5200	4100	5200	4600	3600
	Lower (std UC) – f. dozer & r. stabilizer down	*32,400	*32,400	22,300	*23,800	21,400	14,600	*18,600	15,100	10,600	14,900	11,500	8200	11,800	9200	6500	*9700	8200	5800
	Lower (std UC) – 2 sets stabilizers up	19,600	17,700	13,400	13,000	11,900	9200	9500	8700	6800	7300	6700	5200	5800	5400	4100	5200	4800	3700
	Lower (std UC) – 2 sets stabilizers down	*32,400	*32,400	27,400	*23,800	21,900	17,400	18,100	15,600	12,600	13,700	11,900	9700	10,900	9500	7700	*9700	8500	6900
	MH – stabilizers up – solid tires	18,200	18,200	12,900	12,200	12,200	8900	9100	9100	6700	7100	7100	5200	5700	5700	4200			
	MH – stabilizers down – solid tires	*23,900	*23,900	*23,900	*22,700	*22,700	20,200	*17,700	*17,700	14,500	13,800	13,800	11,200	*10,500	*10,500	9000			
-5 ft	Lower (std UC) – f. stabilizer & r. dozer up	18,000	16,700	12,300	12,000	11,300	8500	8900	8400	6400	6900	6600	5000	5600	5300	4000			
	Lower (std UC) – f. stabilizer & r. dozer down	*23,900	*23,900	20,500	*22,700	*22,700	13,500	17,200	16,800	10,000	13,100	12,900	7800	10,500	10,300	6300			
	Lower (std UC) – f. dozer & r. stabilizer up	18,600	16,100	12,300	12,400	10,900	8500	9200	8100	6400	7100	6300	5000	5800	5100	4000			
	Lower (std UC) – f. dozer & r. stabilizer down	*23,900	*23,900	21,200	*22,700	20,600	13,900	*17,700	14,700	10,200	*13,900	11,300	7900	*10,500	9100	6400			
	Lower (std UC) – 2 sets stabilizers up	18,500	16,600	12,500	12,300	11,200	8600	9100	8300	6400	7100	6500	5000	5700	5300	4000			
	Lower (std UC) – 2 sets stabilizers down	*23,900	*23,900	*23,900	*22,700	21,200	16,800	17,700	15,100	12,200	13,400	11,600	9400	*10,500	9400	7600			

\*Limited by hydraulic rather than tipping load.

Lift capacity ratings are based on ISO 10567:2007, they do not exceed 87% of hydraulic lifting capacity or 75% of tipping load. The load point is the center line of the bucket pivot mounting pin on the stick. The oscillating axle must be locked. Lifting capacities are based on the machine standing on a firm uniform supporting surface. For lifting capacity including bucket and/or quick coupler, the respective weight has to be subtracted from above values. The use of a work tool attachment point to handle/lift objects, could affect the machine lift performance.

Always refer to the appropriate Operation and Maintenance Manual for specific product information.

### Lift Capacities

All values are in kg, hydraulic cab riser, work tool: none, with counterweight (4100 kg), heavy lift on.



#### Undercarriage

#### Boom 6.8 m MH

#### Stick 5.9 m MH

MH or Standard

Stick height	Undercarriage configuration	3000 mm			4500 mm			6000 mm			7500 mm			9000 mm			10 500 mm			12 000 mm			mm			
		Load point height	Load over front	Load over rear	Load over front	Load over rear	Load over side	Load over front	Load over rear	Load over side	Load over front	Load over rear	Load over side	Load over front	Load over rear	Load over side	Load over front	Load over rear	Load over side	Load over front	Load over rear	Load over side				
12 000 mm	MH – stabilizers up – solid tires							6500	6500	4950												4850	4850	3700		
	MH – stabilizers down – solid tires							*7450	*7450	*7450												*5700	*5700	*5700		
	Lower (std UC) – f. stabilizer & r. dozer up							6400	6050	4750												4750	4550	3550		
	Lower (std UC) – f. stabilizer & r. dozer down							*7450	*7450	7100												*5700	*5700	5300		
	Lower (std UC) – f. dozer & r. stabilizer up							6600	5850	4750												4900	4400	3550		
	Lower (std UC) – f. dozer & r. stabilizer down							*7450	*7450	7300												*5700	*5700	5450		
	Lower (std UC) – 2 sets stabilizers up							6550	6050	4800												4900	4500	3550		
	Lower (std UC) – 2 sets stabilizers down							*7450	*7450	*7450												*5700	*5700	*5700		
10 500 mm	MH – stabilizers up – solid tires										4650	4650	3550											3400	3400	2550
	MH – stabilizers down – solid tires										*7250	*7250	7150									*4950	*4950	*4950		
	Lower (std UC) – f. stabilizer & r. dozer up										4550	4350	3400											4750	4550	2400
	Lower (std UC) – f. stabilizer & r. dozer down										*7250	*7250	5050									*4950	*4950	3700		
	Lower (std UC) – f. dozer & r. stabilizer up										4700	4200	3400											3400	3050	2400
	Lower (std UC) – f. dozer & r. stabilizer down										*7250	7250	5150									*4950	*4950	3750		
	Lower (std UC) – 2 sets stabilizers up										4650	4300	3450											3400	3150	2450
	Lower (std UC) – 2 sets stabilizers down										*7250	*7250	6050									*4950	*4950	4000		
9000 mm	MH – stabilizers up – solid tires										4700	4700	3600	3450	3450	2600								2700	2700	2000
	MH – stabilizers down – solid tires										*7450	*7450	7200	6500	6500	5300								*4550	*4550	4250
	Lower (std UC) – f. stabilizer & r. dozer up										4600	4400	3450	3350	3200	2450								2650	2500	1900
	Lower (std UC) – f. stabilizer & r. dozer down										*7450	*7450	5100	6150	6050	3700								*4550	*4550	2950
	Lower (std UC) – f. dozer & r. stabilizer up										4750	4250	3450	3450	3050	2450								2700	2400	1900
	Lower (std UC) – f. dozer & r. stabilizer down										*7450	7300	5250	*6700	5350	3800								*4550	4250	3000
	Lower (std UC) – 2 sets stabilizers up										4700	4350	3500	3450	3150	2500								2700	2500	1900
	Lower (std UC) – 2 sets stabilizers down										*7450	*7450	6150	6300	5500	4500								*4550	4400	3550
7500 mm	MH – stabilizers up – solid tires										4700	4700	3600	3450	3450	2600	2600	2600	1900					2300	2300	1700
	MH – stabilizers down – solid tires										*7500	*7500	7200	6500	6500	5300	5000	5000	4050					*4350	*4350	3650
	Lower (std UC) – f. stabilizer & r. dozer up										4600	4350	3450	3350	3200	2450	2500	2400	1800					2200	2150	1600
	Lower (std UC) – f. stabilizer & r. dozer down										*7500	*7500	5100	6150	6050	3750	4700	4650	2800					4250	4200	2500
	Lower (std UC) – f. dozer & r. stabilizer up										4700	4250	3450	3450	3100	2450	2600	2300	1800					2300	2050	1600
	Lower (std UC) – f. dozer & r. stabilizer down										*7500	7300	5200	*6650	5350	3800	5250	4100	2800					*4350	3650	2600
	Lower (std UC) – 2 sets stabilizers up										4700	4350	3450	3450	3200	2500	2600	2400	1800					2300	2100	1600
	Lower (std UC) – 2 sets stabilizers down										*7500	7500	6100	6300	5500	4500	4800	4200	3400					4350	3800	3050
6000 mm	MH – stabilizers up – solid tires										4550	4550	3500	3350	3350	2550	2550	2550	1900					2050	2050	1500
	MH – stabilizers down – solid tires										*7700	*7700	7100	6400	6400	5250	4950	4950	4050					4100	4100	3200
	Lower (std UC) – f. stabilizer & r. dozer up										4450	4250	3350	3200	3150	2400	2500	2400	1800					2000	1900	1400
	Lower (std UC) – f. stabilizer & r. dozer down										*7700	*7700	4950	6100	5950	3650	4650	4600	2800					3800	3800	2250
	Lower (std UC) – f. dozer & r. stabilizer up										4600	4100	3350	3400	3000	2400	2600	2300	1800					2050	1800	1400
	Lower (std UC) – f. dozer & r. stabilizer down										*7700	7150	5100	*6750	5250	3750	5200	4050	2850					4300	3200	2300
	Lower (std UC) – 2 sets stabilizers up										4600	4250	3350	3350	3100	2450	2550	2350	1800					2050	1900	1400
	Lower (std UC) – 2 sets stabilizers down										*7700	7350	6000	6250	5400	4400	4800	4200	3400					3950	3400	2750
4500 mm	MH – stabilizers up – solid tires							6300	6300	4750	4400	4400	3300	3250	3250	2450	2500	2500	1850	1950	1400	1900	1900	1900	1350	
	MH – stabilizers down – solid tires							*9500	*9500	*9500	*8000	*8000	6950	6300	6300	5100	4900	4900	4000	3950	3950	3200	3800	3800	3100	
	Lower (std UC) – f. stabilizer & r. dozer up							6200	5850	4550	4300	4100	3150	3150	3050	2300	2400	2300	1750	1900	1800	1300	1850	1750	1250	
	Lower (std UC) – f. stabilizer & r. dozer down							*9500	*9500	6900	*8000	7900	4800	5950	5850	3550	4600	4550	2750	3700	3650	2150	3550	3550	2100	
	Lower (std UC) – f. dozer & r. stabilizer up							6350	5650	4550	4450	3950	3150	3300	2900	2300	2500	2200	1750	1950	1700	1300	1900	1650	1250	
	Lower (std UC) – f. dozer & r. stabilizer down							*9500	*9500	7050	*8000	6950	4900	6650	6550	4150	5200	4800	2800	4100	3200	2200	4000	3100	2150	
	Lower (std UC) – 2 sets stabilizers up							6350	5800	4600	4400	4050	3200	3250	3000	2350	2500	2300	1750	1950	1800	1350	1900	1900	1350	
	Lower (std UC) – 2 sets stabilizers down							*9500	*9500	8400	*8000	7150	5800	6100	5300	4300	4750	4100	3350	3800	3300	2650	3700	3200	2500	

\* Limited by hydraulic rather than tipping load.

(continued on next page)

Lift capacity ratings are based on ISO 10567:2007, they do not exceed 87% of hydraulic lifting capacity or 75% of tipping load. The load point is the center line of the bucket pivot mounting pin on the stick. The oscillating axle must be locked. Lifting capacities are based on the machine standing on a firm uniform supporting surface. For lifting capacity including bucket and/or quick coupler, the respective weight has to be subtracted from above values. The use of a work tool attachment point to handle/lift objects, could affect the machine lift performance.

Always refer to the appropriate Operation and Maintenance Manual for specific product information.

**Lift Capacities (continued)**

All values are in kg, hydraulic cab riser, work tool: none, with counterweight (4100 kg), heavy lift on.



**Undercarriage**

**Boom**  
6.8 m MH

**Stick**  
5.9 m MH

MH or Standard

Load point height	Undercarriage configuration	3000 mm		4500 mm		6000 mm		7500 mm		9000 mm		10 500 mm		12 000 mm		mm									
		Load over front	Load over rear	Load over front	Load over rear	Load over front	Load over rear	Load over front	Load over rear	Load over front	Load over rear	Load over front	Load over rear	Load at maximum reach (stick/nose/bucket pin)											
3000 mm	MH – stabilizers up – solid tires			9250	9250	6750	5850	5850	4350	4150	4150	3100	3100	2300	2450	1950	1950	1350	1800	1800	1250				
	MH – stabilizers down – solid tires			*13 350	*13 350	*13 350	*10 250	*10 250	9500	8250	8250	6600	6150	6150	4950	4800	3900	3900	3300	3150	3650	2950			
	Lower (std UC) – f. stabilizer & r. dozer up			9150	8550	6500	5750	5450	4150	4050	3850	2950	3050	2900	2150	2350	2250	1650	1850	1750	1550	1200			
	Lower (std UC) – f. stabilizer & r. dozer down			*13 350	*13 350	10 300	*10 250	*10 250	6450	7800	7650	4550	5800	5700	3400	4500	4450	2650	3650	3600	2100	3450	2000		
	Lower (std UC) – f. dozer & r. stabilizer up			9450	8250	6500	5950	5250	4150	4200	3700	2950	3150	2750	2150	2450	2150	1650	1950	1700	1250	1800	1600	1200	
	Lower (std UC) – f. dozer & r. stabilizer down			*13 350	*13 350	10 650	*10 250	9700	6650	*8350	6700	4650	6500	5000	3500	5050	3900	2700	4100	3150	2150	3850	2950	2050	
1500 mm	MH – stabilizers up – solid tires			8300	8300	5900	5400	5400	3950	3900	3900	2850	2950	2150	2350	2350	1650	1900	1900	1300	1750	1750	1250		
	MH – stabilizers down – solid tires			*14 600	*14 600	*14 600	*10 750	*10 750	9000	7950	7950	6350	5950	5950	4800	4700	4700	3800	3850	3850	3100	3600	3600	2900	
	Lower (std UC) – f. stabilizer & r. dozer up			8200	7600	5650	5300	5000	3750	3800	3600	2700	2900	2750	2050	2250	2150	1550	1800	1750	1250	1700	1600	1150	
	Lower (std UC) – f. stabilizer & r. dozer down			*14 600	*14 600	9300	*10 750	10 600	6000	7500	7350	4300	5600	5500	3250	4400	4350	2550	3600	3550	2050	3400	3350	1950	
	Lower (std UC) – f. dozer & r. stabilizer up			8500	7350	5650	5500	4800	3750	3950	3450	2700	3000	2650	2050	2350	2050	1550	1900	1650	1250	1750	1550	1150	
	Lower (std UC) – f. dozer & r. stabilizer down			*14 600	*14 600	9650	*10 750	9150	6150	8500	8400	4400	6300	4850	3350	4950	3800	2650	4050	3100	2100	3800	2900	2000	
0 mm	MH – stabilizers up – solid tires			*4050	*4050	*4050	7550	5250	5050	5050	3600	3700	3700	2650	2850	2850	2000	2250	2250	1600	1850	1850	1300		
	MH – stabilizers down – solid tires			*4050	*4050	*4050	*14 600	13 800	*10 750	8550	7700	7700	6100	5800	5800	4650	4600	4600	3700	3800	3800	3050			
	Lower (std UC) – f. stabilizer & r. dozer up			*4050	*4050	*4050	7450	6900	4950	4900	4600	3400	3550	3400	2500	2750	2600	1900	2150	2050	1500	1750	1700	1200	
	Lower (std UC) – f. stabilizer & r. dozer down			*4050	*4050	*4050	*14 600	*14 600	8550	10 450	10 100	5600	7250	7100	4050	5450	5350	3100	4350	4250	2500	3550	3500	2050	
	Lower (std UC) – f. dozer & r. stabilizer up			*4050	*4050	*4050	7750	6600	4950	5100	4450	3400	3700	3250	2500	2850	2500	1900	2250	2000	1500	1850	1600	1200	
	Lower (std UC) – f. dozer & r. stabilizer down			*4050	*4050	*4050	*14 600	14 300	8850	*10 750	8700	5750	8200	6150	4150	6150	4700	3200	4850	3750	2550	4000	3050	2100	
-1500 mm	MH – stabilizers up – solid tires			7150	7150	4900	4750	4750	3350	3500	3500	2500	2750	2750	1950	2200	2200	1550							
	MH – stabilizers down – solid tires			*10 400	*10 400	*10 400	*9950	*9950	8250	7500	7500	5900	5700	5700	4550	4550	4550	3650							
	Lower (std UC) – f. stabilizer & r. dozer up			7050	6500	4600	4650	4350	3150	3400	3200	2350	2650	2500	1800	2100	2000	1450							
	Lower (std UC) – f. stabilizer & r. dozer down			*10 400	*10 400	8100	*9950	9800	5300	7050	6900	3900	5350	5250	3000	4250	4200	2450							
	Lower (std UC) – f. dozer & r. stabilizer up			7300	6250	4600	4850	4200	3150	3550	3100	2350	2750	2400	1800	2200	1900	1450							
	Lower (std UC) – f. dozer & r. stabilizer down			*10 400	*10 400	8400	*9950	8400	5500	*7750	5950	4000	6050	4550	3100	*4750	3650	2500							
Lower (std UC) – 2 sets stabilizers up					7250	6450	4650	4800	4350	3200	3500	3200	2350	2750	2500	1850	2200	2000	1450						
Lower (std UC) – 2 sets stabilizers down					*10 400	*10 400	*9950	8650	6700	7250	6150	4850	5500	4700	3750	4400	3800	3000							

\*Limited by hydraulic rather than tipping load.

Lift capacity ratings are based on ISO 10567:2007, they do not exceed 87% of hydraulic lifting capacity or 75% of tipping load. The load point is the center line of the bucket pivot mounting pin on the stick. The oscillating axle must be locked. Lifting capacities are based on the machine standing on a firm uniform supporting surface. For lifting capacity including bucket and/or quick coupler, the respective weight has to be subtracted from above values. The use of a work tool attachment point to handle/lift objects, could affect the machine lift performance.

Always refer to the appropriate Operation and Maintenance Manual for specific product information.

### Lift Capacities

All values are in lb, hydraulic cab riser, work tool: none, with counterweight (9040 lb), heavy lift on.



#### Undercarriage

#### Boom 22'4" MH

#### Stick 19'4" MH

MH or Standard

Stick	Undercarriage configuration	10 ft			15 ft			20 ft			25 ft			30 ft			35 ft			40 ft			ft		
		Load over front	Load over rear	Load over side	Load over front	Load over rear	Load over side	Load over front	Load over rear	Load over side	Load over front	Load over rear	Load over side	Load over front	Load over rear	Load over side	Load over front	Load over rear	Load over side						
40 ft	MH – stabilizers up – solid tires							13,900	13,900	10,500													11,500	11,500	8700
	MH – stabilizers down – solid tires							*15,600	*15,600	*15,600													*12,900	*12,900	*12,900
	Lower (std UC) – f. stabilizer & r. dozer up							13,600	12,900	10,100													11,200	10,700	8300
	Lower (std UC) – f. stabilizer & r. dozer down							*15,600	*15,600	15,100													*12,900	*12,900	12,500
	Lower (std UC) – f. dozer & r. stabilizer up							14,000	12,500	10,100													11,600	10,300	8300
	Lower (std UC) – f. dozer & r. stabilizer down							*15,600	*15,600	15,500													*12,900	*12,900	12,800
	Lower (std UC) – 2 sets stabilizers up							14,000	12,900	10,200													11,500	10,600	8400
Lower (std UC) – 2 sets stabilizers down							*15,600	*15,600	*15,600													*12,900	*12,900	*12,900	
35 ft	MH – stabilizers up – solid tires										9900	9900	7600									7700	7700	5800	
	MH – stabilizers down – solid tires										*15,300	*15,300	15,300									*11,000	*11,000	*11,000	
	Lower (std UC) – f. stabilizer & r. dozer up										9700	9200	7200									7500	7200	5500	
	Lower (std UC) – f. stabilizer & r. dozer down										*15,300	*15,300	10,800									*11,000	*11,000	8400	
	Lower (std UC) – f. dozer & r. stabilizer up										10,000	8900	7200									7800	6900	5500	
	Lower (std UC) – f. dozer & r. stabilizer down										*15,300	*15,300	11,000									*11,000	*11,000	8600	
	Lower (std UC) – 2 sets stabilizers up										9900	9200	7300									7700	7100	5600	
Lower (std UC) – 2 sets stabilizers down										*15,300	*15,300	13,000									*11,000	*11,000	10,100		
30 ft	MH – stabilizers up – solid tires										10,100	10,100	7700	7300	7300	5500						6100	6100	4500	
	MH – stabilizers down – solid tires										*16,300	*16,300	15,500	13,900	13,900	11,300						*10,100	*10,100	9500	
	Lower (std UC) – f. stabilizer & r. dozer up										9900	9400	7400	7100	6800	5300						5900	5600	4200	
	Lower (std UC) – f. stabilizer & r. dozer down										*16,300	*16,300	11,000	13,100	12,900	8000						*10,100	*10,100	6600	
	Lower (std UC) – f. dozer & r. stabilizer up										10,200	9100	7400	7400	6600	5300						6100	5400	4200	
	Lower (std UC) – f. dozer & r. stabilizer down										*16,300	15,700	11,200	*14,300	11,400	8100						*10,100	9600	8800	
	Lower (std UC) – 2 sets stabilizers up										10,100	9400	7500	7300	6800	5300						6100	5600	4300	
Lower (std UC) – 2 sets stabilizers down										*16,300	16,100	13,200	13,500	11,700	9600						*10,100	9800	8000		
25 ft	MH – stabilizers up – solid tires										16,300	16,300	15,500	13,900	13,900	11,400	5500	5500	4100			5100	5100	3700	
	MH – stabilizers down – solid tires										*16,300	*16,300	15,500	13,900	13,900	11,400	10,700	10,700	8700			*9700	*9700	8200	
	Lower (std UC) – f. stabilizer & r. dozer up										9800	9400	7400	7200	6800	5300	5300	5100	3800			5000	4700	3500	
	Lower (std UC) – f. stabilizer & r. dozer down										*16,300	*16,300	10,900	13,200	13,000	8000	10,000	9900	6000			9400	9300	5600	
	Lower (std UC) – f. dozer & r. stabilizer up										10,200	9100	7400	7400	6600	5300	5500	4900	3800			5200	4500	3500	
	Lower (std UC) – f. dozer & r. stabilizer down										*16,300	15,600	11,200	*14,500	11,400	8200	11,200	8700	6200			*9700	8200	5700	
	Lower (std UC) – 2 sets stabilizers up										10,100	9300	7400	7400	6800	5300	5500	5100	3900			5100	4700	3600	
Lower (std UC) – 2 sets stabilizers down										*16,300	16,100	13,100	13,500	11,800	9600	10,300	9000	7300			*9700	8400	6000		
20 ft	MH – stabilizers up – solid tires										16,700	16,700	15,200	13,800	13,800	11,200	10,700	10,700	8700			9000	9000	7200	
	MH – stabilizers down – solid tires										*16,700	*16,700	15,200	13,800	13,800	11,200	10,700	10,700	8700			*9500	*9500	7200	
	Lower (std UC) – f. stabilizer & r. dozer up										9600	9200	7200	7000	6700	5200	5300	5100	3800			4400	4200	3100	
	Lower (std UC) – f. stabilizer & r. dozer down										*16,700	*16,700	10,700	13,100	12,800	7900	10,000	9900	6000			8500	8400	5000	
	Lower (std UC) – f. dozer & r. stabilizer up										9600	8900	7200	7300	6500	5200	5500	4900	3800			4600	4000	3100	
	Lower (std UC) – f. dozer & r. stabilizer down										*16,700	15,400	11,000	14,600	11,300	8100	11,200	8700	6100			*9500	7400	5100	
	Lower (std UC) – 2 sets stabilizers up										9900	9100	7200	7200	6700	5200	5500	5100	3900			4500	4200	3100	
Lower (std UC) – 2 sets stabilizers down										*16,700	15,800	12,900	13,400	11,600	9500	10,300	9000	7300			8700	7600	6100		
15 ft	MH – stabilizers up – solid tires										13,500	13,500	10,200	9500	9500	7100	7000	7000	5200	5400	5400	3900	4200	4200	3000
	MH – stabilizers down – solid tires										*20,700	*20,700	*20,700	*17,400	*17,400	14,800	13,500	13,500	11,000	10,500	10,500	8500	8400	8400	6800
	Lower (std UC) – f. stabilizer & r. dozer up										13,300	12,600	9900	9200	8800	6900	6800	6500	5000	5200	5000	3700	4000	3900	2800
	Lower (std UC) – f. stabilizer & r. dozer down										*20,700	*20,700	14,800	*17,400	17,000	10,300	12,800	12,600	7600	9900	9800	5900	7900	7900	4600
	Lower (std UC) – f. dozer & r. stabilizer up										13,700	12,200	9900	9500	8500	6900	7100	6300	5000	5400	4800	3700	4200	3700	2800
	Lower (std UC) – f. dozer & r. stabilizer down										*20,700	*20,700	15,200	*17,400	15,000	10,600	14,300	11,100	7800	11,100	8600	6000	8900	6900	4700
	Lower (std UC) – 2 sets stabilizers up										13,600	12,600	9900	9500	8800	6900	7000	6500	5000	5400	4900	3800	4200	3700	2800
Lower (std UC) – 2 sets stabilizers down										*20,700	*20,700	18,000	*17,400	15,400	12,500	13,100	11,400	9300	10,200	8900	7200	8100	7100	5700	

\* Limited by hydraulic rather than tipping load.

(continued on next page)

Lift capacity ratings are based on ISO 10567:2007, they do not exceed 87% of hydraulic lifting capacity or 75% of tipping load. The load point is the center line of the bucket pivot mounting pin on the stick. The oscillating axle must be locked. Lifting capacities are based on the machine standing on a firm uniform supporting surface. For lifting capacity including bucket and/or quick coupler, the respective weight has to be subtracted from above values. The use of a work tool attachment point to handle/lift objects, could affect the machine lift performance.

Always refer to the appropriate Operation and Maintenance Manual for specific product information.

**Lift Capacities (continued)**

All values are in lb, hydraulic cab riser, work tool: none, with counterweight (9040 lb), heavy lift on.



**Undercarriage**

**Boom**  
22" MH

**Stick**  
19" MH

MH or Standard

Stick ft	Undercarriage configuration	10 ft			15 ft			20 ft			25 ft			30 ft			35 ft			40 ft			ft			
		Load point height	Load over front	Load over rear	Load point height	Load over front	Load over rear	Load point height	Load over front	Load over rear	Load point height	Load over front	Load over rear	Load point height	Load over front	Load over rear	Load point height	Load over front	Load over rear	Load point height	Load over front	Load over rear				
10 ft	MH – stabilizers up – solid tires				19,900	19,900	14,600	12,700	12,700	9,400	9,000	9,000	6,700	6,700	4,900	5,200	5,200	3,800	4,100	4,100	2,900	4,000	4,000	2,800		
	MH – stabilizers down – solid tires				*28,900	*28,900	*28,900	*22,200	*22,200	20,500	17,700	17,700	14,200	13,200	13,200	10,700	10,300	10,300	8,400	8,400	8,400	6,700	8,100	8,100	6,500	
	Lower (std UC) – f. stabilizer & r. dozer up				19,700	18,400	14,000	12,400	11,700	9,000	8,700	8,300	6,300	6,500	6,200	4,700	5,000	4,800	3,500	4,000	3,800	2,700	3,800	3,700	2,600	
	Lower (std UC) – f. stabilizer & r. dozer down				*28,900	*28,900	22,200	*22,200	*22,200	13,900	16,800	16,400	9,800	12,500	12,200	7,300	9,700	9,600	5,700	7,800	7,700	4,500	7,600	7,500	4,400	
	Lower (std UC) – f. dozer & r. stabilizer up				20,400	17,800	14,000	12,800	11,300	9,000	9,000	8,000	6,300	6,800	6,000	4,700	5,200	4,600	3,500	4,100	3,600	2,700	4,000	3,500	2,600	
	Lower (std UC) – f. dozer & r. stabilizer down				*28,900	*28,900	22,900	*22,200	*22,200	20,800	14,300	18,100	14,400	10,000	14,000	10,700	7,500	10,900	8,400	5,900	8,800	6,800	4,700	8,500	6,500	
5 ft	MH – stabilizers up – solid tires				17,900	17,900	12,800	11,700	11,700	8,500	8,400	8,400	6,100	6,400	6,400	4,600	5,000	5,000	3,600	4,000	4,000	2,800	3,900	3,900	2,700	
	MH – stabilizers down – solid tires				*31,700	*31,700	31,600	*23,300	*23,300	19,300	17,100	17,100	13,600	12,800	12,800	10,300	10,100	10,100	8,200	8,300	8,300	6,700	8,000	8,000	6,400	
	Lower (std UC) – f. stabilizer & r. dozer up				17,600	16,400	12,200	11,400	10,800	8,100	8,200	7,800	5,800	6,200	5,900	4,400	4,800	4,600	3,400	3,900	3,700	2,600	3,700	3,600	2,500	
	Lower (std UC) – f. stabilizer & r. dozer down				*31,700	*31,700	20,000	*23,300	*23,300	12,900	16,200	15,800	9,200	12,100	11,900	7,000	9,500	9,400	5,500	7,700	7,600	4,500	7,400	7,400	4,300	
	Lower (std UC) – f. dozer & r. stabilizer up				18,300	15,800	12,200	11,800	10,400	8,100	8,500	7,500	5,800	6,400	5,700	4,400	5,100	4,400	3,400	4,100	3,500	2,600	3,900	3,400	2,500	
	Lower (std UC) – f. dozer & r. stabilizer down				*31,700	*31,700	20,700	*23,300	*23,300	13,300	18,200	13,800	9,500	13,600	10,400	7,200	10,700	8,200	5,700	8,700	6,700	4,600	8,400	6,400	4,400	
0 ft	MH – stabilizers up – solid tires				16,300	16,300	11,300	10,300	10,900	7,700	7,900	7,900	5,700	6,100	6,100	4,400	4,900	4,900	3,400	3,400	3,400	2,500	2,500	2,500	1,900	
	MH – stabilizers down – solid tires	*9200	*9200	*9200	*31,700	*31,700	25,600	*23,300	*23,300	18,400	16,500	16,500	13,100	12,500	12,500	10,000	9,900	9,900	8,000							
	Lower (std UC) – f. stabilizer & r. dozer up				*9200	*9200	16,000	14,900	10,700	10,600	10,000	7,300	7,700	7,300	5,400	5,900	5,600	4,100	4,700	4,500	3,200					
	Lower (std UC) – f. stabilizer & r. dozer down				*9200	*9200	*31,700	*31,700	18,400	22,400	12,000	15,600	15,200	8,700	11,800	11,600	6,700	9,300	9,200	5,400						
	Lower (std UC) – f. dozer & r. stabilizer up				*9200	*9200	16,600	14,300	10,700	11,000	9,600	7,300	8,000	7,000	5,400	6,200	5,400	4,100	4,900	4,300	3,200					
	Lower (std UC) – f. dozer & r. stabilizer down				*9200	*9200	*31,700	30,600	19,000	*23,300	18,700	12,400	17,600	13,200	9,000	13,200	10,100	6,900	10,500	8,000	5,500					
-5 ft	MH – stabilizers up – solid tires				15,400	15,400	10,500	10,300	10,300	7,200	7,600	7,600	5,300	5,900	5,900	4,100	4,800	4,800	3,300							
	MH – stabilizers down – solid tires				*24,000	*24,000	*24,000	*21,500	*21,500	17,700	16,100	16,100	12,700	12,300	12,300	9,800	9,800	9,800	7,900							
	Lower (std UC) – f. stabilizer & r. dozer up				15,100	14,000	9,900	10,000	9,400	6,800	7,300	6,900	5,000	5,700	5,400	3,900	4,600	4,300	3,100							
	Lower (std UC) – f. stabilizer & r. dozer down				*24,000	*24,000	17,400	*21,500	*21,500	11,500	15,200	14,800	8,400	11,500	11,300	6,500	9,200	9,100	5,200							
	Lower (std UC) – f. dozer & r. stabilizer up				15,700	13,400	9,900	10,400	9,000	6,800	7,700	6,600	5,000	5,900	5,200	3,900	4,800	4,100	3,100							
	Lower (std UC) – f. dozer & r. stabilizer down				*24,000	*24,000	18,100	*21,500	18,000	11,800	*16,800	12,800	8,600	13,000	9,800	6,700	*10,100	7,900	5,400							

\*Limited by hydraulic rather than tipping load.

Lift capacity ratings are based on ISO 10567:2007, they do not exceed 87% of hydraulic lifting capacity or 75% of tipping load. The load point is the center line of the bucket pivot mounting pin on the stick. The oscillating axle must be locked. Lifting capacities are based on the machine standing on a firm uniform supporting surface. For lifting capacity including bucket and/or quick coupler, the respective weight has to be subtracted from above values. The use of a work tool attachment point to handle/lift objects, could affect the machine lift performance.

Always refer to the appropriate Operation and Maintenance Manual for specific product information.



### Lift Capacities

All values are in kg, hydraulic cab riser, work tool: none, with counterweight (5200 kg), heavy lift on.



Undercarriage MH or Standard		Boom 6.8 m MH												Stick 5.9 m MH						mm				
		3000 mm			4500 mm			6000 mm			7500 mm			9000 mm			10 500 mm		12 000 mm					
Load point height	Undercarriage configuration	Load over front	Load over rear	Load over side	Load over front	Load over rear	Load over side	Load over front	Load over rear	Load over side	Load over front	Load over rear	Load over side	Load over front	Load over rear	Load over side	Load over front	Load over rear	Load over side	Load at maximum reach (sticknose/bucket pin)				
		12 000 mm	MH – stabilizers up – solid tires																			5400	5400	4150
MH – stabilizers down – solid tires																					*5700	*5700	*5700	
Lower (std UC) – f. stabilizer & r. dozer up																					5350	5050	4000	
Lower (std UC) – f. stabilizer & r. dozer down																					*7450	*7450	*7450	
Lower (std UC) – f. dozer & r. stabilizer up																					*7450	*7450	*7450	
Lower (std UC) – f. dozer & r. stabilizer down																					7300	6550	5350	
Lower (std UC) – 2 sets stabilizers up																					*7450	*7450	*7450	
10 500 mm	MH – stabilizers up – solid tires																				5450	5050	4050	8910
	MH – stabilizers down – solid tires																				*5700	*5700	*5700	
	Lower (std UC) – f. stabilizer & r. dozer up																				5450	5050	4050	
	Lower (std UC) – f. stabilizer & r. dozer down																				*7450	*7450	*7450	
	Lower (std UC) – f. dozer & r. stabilizer up																				7250	6700	5400	
	Lower (std UC) – f. dozer & r. stabilizer down																				*7450	*7450	*7450	
	Lower (std UC) – 2 sets stabilizers up																				7250	6700	5400	
9000 mm	MH – stabilizers up – solid tires																				5200	4800	3900	10 180
	MH – stabilizers down – solid tires																				*7250	*7250	*7250	
	Lower (std UC) – f. stabilizer & r. dozer up																				5200	4700	3850	
	Lower (std UC) – f. stabilizer & r. dozer down																				*7250	*7250	*7250	
	Lower (std UC) – f. dozer & r. stabilizer up																				5200	4700	3850	
	Lower (std UC) – f. dozer & r. stabilizer down																				*7250	*7250	*7250	
	Lower (std UC) – 2 sets stabilizers up																				5200	4800	3900	
7500 mm	MH – stabilizers up – solid tires																				5200	4800	3900	11 110
	MH – stabilizers down – solid tires																				*7250	*7250	*7250	
	Lower (std UC) – f. stabilizer & r. dozer up																				5200	4700	3850	
	Lower (std UC) – f. stabilizer & r. dozer down																				*7250	*7250	*7250	
	Lower (std UC) – f. dozer & r. stabilizer up																				5200	4700	3850	
	Lower (std UC) – f. dozer & r. stabilizer down																				*7250	*7250	*7250	
	Lower (std UC) – 2 sets stabilizers up																				5200	4800	3900	
6000 mm	MH – stabilizers up – solid tires																				5200	4800	3900	11 760
	MH – stabilizers down – solid tires																				*7250	*7250	*7250	
	Lower (std UC) – f. stabilizer & r. dozer up																				5200	4700	3850	
	Lower (std UC) – f. stabilizer & r. dozer down																				*7250	*7250	*7250	
	Lower (std UC) – f. dozer & r. stabilizer up																				5200	4700	3850	
	Lower (std UC) – f. dozer & r. stabilizer down																				*7250	*7250	*7250	
	Lower (std UC) – 2 sets stabilizers up																				5200	4800	3900	
4500 mm	MH – stabilizers up – solid tires																				5200	4800	3900	12 200
	MH – stabilizers down – solid tires																				*7250	*7250	*7250	
	Lower (std UC) – f. stabilizer & r. dozer up																				6950	6950	5350	
	Lower (std UC) – f. stabilizer & r. dozer down																				*9500	*9500	*9500	
	Lower (std UC) – f. dozer & r. stabilizer up																				6900	6500	5150	
	Lower (std UC) – f. dozer & r. stabilizer down																				*9500	*9500	*9500	
	Lower (std UC) – 2 sets stabilizers up																				7100	6350	5150	

\* Limited by hydraulic rather than tipping load.























(continued on next page)

Lift capacity ratings are based on ISO 10567:2007, they do not exceed 87% of hydraulic lifting capacity or 75% of tipping load. The load point is the center line of the bucket pivot mounting pin on the stick. The oscillating axle must be locked. Lifting capacities are based on the machine standing on a firm uniform supporting surface. For lifting capacity including bucket and/or quick coupler, the respective weight has to be subtracted from above values. The use of a work tool attachment point to handle/lift objects, could affect the machine lift performance.

Always refer to the appropriate Operation and Maintenance Manual for specific product information.

**Lift Capacities (continued)**

All values are in kg, hydraulic cab riser, work tool: none, with counterweight (5200 kg), heavy lift on.

		 Load point height		 Load over front		 Load over rear		 Load over side		 Load at maximum reach (sticknose/bucket pin)								
		<b>Undercarriage</b>						<b>Boom</b>				<b>Stick</b>						
		MH or Standard						6.8 m MH				5.9 m MH						
	Undercarriage configuration	3000 mm		4500 mm		6000 mm		7500 mm		9000 mm		10 500 mm		12 000 mm			mm	
																		
3000 mm	MH – stabilizers up – solid tires																	
	MH – stabilizers down – solid tires																	
	Lower (std UC) – f. stabilizer & r. dozer up																	
	Lower (std UC) – f. dozer & r. stabilizer up																	
	Lower (std UC) – f. dozer & r. stabilizer down																	
	Lower (std UC) – 2 sets stabilizers up																	
1500 mm	MH – stabilizers up – solid tires																	
	MH – stabilizers down – solid tires																	
	Lower (std UC) – f. stabilizer & r. dozer up																	
	Lower (std UC) – f. dozer & r. stabilizer up																	
	Lower (std UC) – f. dozer & r. stabilizer down																	
	Lower (std UC) – 2 sets stabilizers up																	
0 mm	MH – stabilizers up – solid tires	*4050	*4050	*4050	8600	8600	6100	5700	4150	4200	4200	3100	3250	2400	2600	2600	1900	1550
	MH – stabilizers down – solid tires	*4050	*4050	*4050	*14 600	*14 600	*14 600	*10 750	*9 450	*8400	*8400	6750	6400	6400	5200	5100	4150	*4000
	Lower (std UC) – f. stabilizer & r. dozer up	*4050	*4050	*4050	8500	7850	5800	5600	5300	3950	4100	3900	2950	3150	3000	2250	2450	1800
	Lower (std UC) – f. dozer & r. stabilizer up	*4050	*4050	*4050	*14 600	*14 600	9650	*10 750	6350	8050	7850	4600	8050	5950	3550	4800	4750	2850
	Lower (std UC) – f. dozer & r. stabilizer down	*4050	*4050	*4050	8800	7600	5800	5800	5100	3950	4250	3750	2950	3300	2900	2250	2650	2300
	Lower (std UC) – 2 sets stabilizers up	*4050	*4050	*4050	*14 600	*14 600	10 000	*10 750	9650	6500	*8400	6850	4750	*6750	5250	3650	5400	4150
-1500 mm	MH – stabilizers up – solid tires				8200	8200	5750	5450	5450	3950	4050	4050	2950	3150	3150	2200	2550	1850
	MH – stabilizers down – solid tires				*10 400	*10 400	*10 400	*9950	*9950	9150	*7750	*7750	6550	*6150	*6150	5050	*4750	4100
	Lower (std UC) – f. stabilizer & r. dozer up				8100	7500	5450	5350	5050	3750	3950	3750	2800	3050	2900	2150	2450	2350
	Lower (std UC) – f. dozer & r. stabilizer up				*10 400	*10 400	9250	*9950	*9950	6050	*7750	7650	4450	5950	5850	3450	*4750	4700
	Lower (std UC) – f. dozer & r. stabilizer down				8400	7200	5450	5550	4950	3750	4100	3600	2800	3200	2800	2150	2550	2250
	Lower (std UC) – 2 sets stabilizers up				*10 400	*10 400	9550	*9950	9300	6250	*7750	6650	4550	*6150	5100	3550	*4750	4100

\*Limited by hydraulic rather than tipping load.  
 Lift capacity ratings are based on ISO 10567:2007, they do not exceed 87% of hydraulic lifting capacity or 75% of tipping load. The load point is the center line of the bucket pivot mounting pin on the stick. The oscillating axle must be locked. Lifting capacities are based on the machine standing on a firm uniform supporting surface. For lifting capacity including bucket and/or quick coupler, the respective weight has to be subtracted from above values. The use of a work tool attachment point to handle/lift objects, could affect the machine lift performance.  
 Always refer to the appropriate Operation and Maintenance Manual for specific product information.

### Lift Capacities

All values are in lb, hydraulic cab riser, work tool: none, with counterweight (11,470 lb), heavy lift on.



#### Undercarriage

#### Boom

#### Stick

MH or Standard

22'4" MH

19'4" MH

Stick	Undercarriage configuration	10 ft			15 ft			20 ft			25 ft			30 ft			35 ft			40 ft			ft			
		Load point height	Load over front	Load over rear	Load over side	Load over front	Load over rear	Load over side	Load over front	Load over rear	Load over side	Load over front	Load over rear	Load over side	Load over front	Load over rear	Load over side	Load over front	Load over rear	Load over side						
40 ft	MH – stabilizers up – solid tires							15,300	15,300	11,800												12,700	12,700	9800		
	MH – stabilizers down – solid tires							*15,600	*15,600	*15,600												*12,900	*12,900	*12,900		
	Lower (std UC) – f. stabilizer & r. dozer up							15,200	14,300	11,400												12,600	11,900	9400		
	Lower (std UC) – f. stabilizer & r. dozer down							*15,600	*15,600	*15,600												*12,900	*12,900	*12,900		
	Lower (std UC) – f. dozer & r. stabilizer up							*15,600	13,900	11,400												*12,900	11,600	9400		
	Lower (std UC) – f. dozer & r. stabilizer down							*15,600	*15,600	*15,600												*12,900	*12,900	*12,900		
	Lower (std UC) – 2 sets stabilizers up							15,500	14,300	11,500												*12,900	11,300	9500		
Lower (std UC) – 2 sets stabilizers down							*15,600	*15,600	*15,600												*12,900	*12,900	*12,900			
35 ft	MH – stabilizers up – solid tires										11,000	11,000	8500									8700	8700	6600		
	MH – stabilizers down – solid tires										*15,300	*15,300	*15,300									*11,000	*11,000	*11,000		
	Lower (std UC) – f. stabilizer & r. dozer up										10,800	10,300	8200									8500	8100	6300		
	Lower (std UC) – f. stabilizer & r. dozer down										*15,300	*15,300	12,000									*11,000	*11,000	9400		
	Lower (std UC) – f. dozer & r. stabilizer up										11,200	10,000	8200										8700	7800	6300	
	Lower (std UC) – f. dozer & r. stabilizer down										*15,300	*15,300	12,200									*11,000	*11,000	9600		
	Lower (std UC) – 2 sets stabilizers up										11,100	10,300	8300										8700	8000	6400	
Lower (std UC) – 2 sets stabilizers down										*15,300	*15,300	14,300									*11,000	*11,000	*11,000			
30 ft	MH – stabilizers up – solid tires										11,200	11,200	8700	8200	8200	6300						6900	6900	5200		
	MH – stabilizers down – solid tires										*16,300	*16,300	*16,300	*14,300	*14,300	12,500						*10,100	*10,100	*10,100		
	Lower (std UC) – f. stabilizer & r. dozer up										11,000	10,500	8400	8100	7700	6100						6700	6400	5000		
	Lower (std UC) – f. stabilizer & r. dozer down										*16,300	*16,300	12,200	*14,300	14,200	8900						*10,100	*10,100	7500		
	Lower (std UC) – f. dozer & r. stabilizer up										11,300	10,200	8400	8300	7400	6100							6900	6200	5000	
	Lower (std UC) – f. dozer & r. stabilizer down										*16,300	*16,300	12,400	*14,300	12,600	9100							*10,100	*10,100	7600	
	Lower (std UC) – 2 sets stabilizers up										11,300	10,500	8500	8300	7700	6100							6900	6400	5000	
Lower (std UC) – 2 sets stabilizers down										*16,300	*16,300	14,500	*14,300	12,900	10,700							*10,100	*10,100	8900		
25 ft	MH – stabilizers up – solid tires										11,200	11,200	8700	8300	8300	6500	6300	4700				5900	5900	4400		
	MH – stabilizers down – solid tires										*16,300	*16,300	*16,300	*14,500	*14,500	12,500	11,700	11,700	9600			*9700	*9700	9100		
	Lower (std UC) – f. stabilizer & r. dozer up										11,000	10,500	8400	8100	7700	6100	6100	5800	4500			5700	5400	4200		
	Lower (std UC) – f. stabilizer & r. dozer down										*16,300	*16,300	12,100	14,500	14,200	9000	11,100	10,900	6800			*9700	*9700	6400		
	Lower (std UC) – f. dozer & r. stabilizer up										11,300	10,200	8400	8300	7500	6100	6300	5600	4500				5900	5200	4200	
	Lower (std UC) – f. dozer & r. stabilizer down										*16,300	*16,300	12,400	*14,500	12,600	9200	*11,900	9700	7000				*9700	9100	6500	
	Lower (std UC) – 2 sets stabilizers up										11,300	10,400	8400	8300	7700	6100	6300	5800	4600				5900	5400	4200	
Lower (std UC) – 2 sets stabilizers down										*16,300	*16,300	14,500	*14,500	13,000	10,700	11,400	10,000	8200				*9700	9400	7100		
20 ft	MH – stabilizers up – solid tires										11,000	11,000	8500	8100	8100	6200	6300	6300	4700				5200	5200	3900	
	MH – stabilizers down – solid tires										*16,700	*16,700	16,700	*14,700	*14,700	12,400	11,700	11,700	9600				*9500	*9500	8200	
	Lower (std UC) – f. stabilizer & r. dozer up										10,800	10,300	8100	8000	7500	6200	6100	5900	4500				5100	4900	3700	
	Lower (std UC) – f. stabilizer & r. dozer down										*16,700	*16,700	11,900	14,400	14,100	8800	11,100	10,900	6800				9400	9300	5700	
	Lower (std UC) – f. dozer & r. stabilizer up										11,100	10,000	8100	8200	7400	6000	6300	5500	4500				5300	4700	3700	
	Lower (std UC) – f. dozer & r. stabilizer down										*16,700	*16,700	12,200	*14,700	12,500	9000	12,300	9700	6900				*9500	8200	5800	
	Lower (std UC) – 2 sets stabilizers up										11,000	10,200	8200	8200	7600	6000	6300	5900	4500				5200	4800	3700	
Lower (std UC) – 2 sets stabilizers down										*16,700	*16,700	14,200	*14,700	12,800	10,600	11,400	9900	8200				*9500	8500	6900		
15 ft	MH – stabilizers up – solid tires										15,000	15,000	11,500	10,600	10,600	8100	7900	7900	6000	6100	6100	4800		4900	4900	3600
	MH – stabilizers down – solid tires										*20,700	*20,700	*20,700	*17,400	*17,400	16,200	14,800	14,800	12,100	11,600	11,600	9500		9300	9300	7600
	Lower (std UC) – f. stabilizer & r. dozer up										14,800	14,000	11,100	10,400	9900	7900	7700	7400	5900	6000	5700	4400		4700	4500	3400
	Lower (std UC) – f. stabilizer & r. dozer down										*20,700	*20,700	16,400	*17,400	*17,400	11,500	14,100	13,800	8600	11,000	10,800	6700		8800	8700	5300
	Lower (std UC) – f. dozer & r. stabilizer up										15,300	13,600	11,100	10,700	9600	7900	8000	7100	5900	6200	5500	4400		4900	4300	3400
	Lower (std UC) – f. dozer & r. stabilizer down										*20,700	*20,700	16,900	*17,400	16,500	11,800	*14,900	12,300	8900	12,200	9600	6800		*9500	7700	5400
	Lower (std UC) – 2 sets stabilizers up										15,200	14,000	11,200	10,600	9800	7900	7900	7300	5900	6100	5700	4400		4900	4300	3400
Lower (std UC) – 2 sets stabilizers down										*20,700	*20,700	19,900	*17,400	16,900	13,800	14,400	12,600	10,300	11,200	9800	8100		9000	7900	6400	

\* Limited by hydraulic rather than tipping load.

(continued on next page)

Lift capacity ratings are based on ISO 10567:2007, they do not exceed 87% of hydraulic lifting capacity or 75% of tipping load. The load point is the center line of the bucket pivot mounting pin on the stick. The oscillating axle must be locked. Lifting capacities are based on the machine standing on a firm uniform supporting surface. For lifting capacity including bucket and/or quick coupler, the respective weight has to be subtracted from above values. The use of a work tool attachment point to handle/lift objects, could affect the machine lift performance.

Always refer to the appropriate Operation and Maintenance Manual for specific product information.

# Lifting Capacities ● MH3024 (Grenoble Sourced)

# Material Handlers

## Lift Capacities (continued)

All values are in lb, hydraulic cab riser, work tool: none, with counterweight (11,470 lb), heavy lift on.

		Load point height	Load over front	Load over rear	Load over side	Load at maximum reach (sticknose/bucket pin)																						
		<b>Undercarriage</b>					<b>Boom</b>					<b>Stick</b>																
		MH or Standard					22'4" MH					19'4" MH																
	Undercarriage configuration	10 ft			15 ft			20 ft			25 ft			30 ft			35 ft			40 ft			ft					
10 ft	MH – stabilizers up – solid tires						22,100	22,100	16,500	14,100	14,100	10,700	10,100	10,100	7600	7600	7600	5700	6000	6000	4400	4800	4800	3500	4600	4600	3400	40.78
	MH – stabilizers down – solid tires						*28,900	*28,900	*28,900	*22,200	*22,200	*22,200	*18,100	*18,100	15,700	14,500	14,500	11,800	11,400	11,400	9300	9200	9200	7500	9000	9000	7300	
	Lower (std UC) – f. stabilizer & r. dozer up						22,000	20,500	15,800	13,900	13,200	10,300	9900	9400	7300	7400	7100	5500	5800	5500	4200	4600	4400	3300	4500	4300	3200	
	Lower (std UC) – f. stabilizer & r. dozer down						*28,900	*28,900	24,600	*22,200	*22,200	15,500	*18,100	18,000	11,000	13,800	13,500	8300	10,800	10,600	6500	8700	8600	5200	8500	8300	5100	
	Lower (std UC) – f. dozer & r. stabilizer up						22,600	19,900	15,800	14,400	12,800	10,300	10,200	9100	7300	7700	6800	5500	6000	5300	4200	4800	4200	3300	4700	4100	3200	
	Lower (std UC) – f. dozer & r. stabilizer down						*28,900	*28,900	25,400	*22,200	*22,200	15,900	*18,100	15,900	11,300	*15,100	11,900	8500	12,000	9400	6700	9700	7600	5300	9400	7400	5200	
5 ft	Lower (std UC) – 2 sets stabilizers up						22,500	20,400	16,000	14,300	13,100	10,400	10,100	9400	7400	7600	7100	5500	6000	5500	4300	4800	4400	3300	4600	4200	3200	
	Lower (std UC) – 2 sets stabilizers down						*28,900	*28,900	*28,900	*22,200	*22,200	18,900	*18,100	16,300	13,300	14,100	12,300	10,000	11,100	9600	7900	9000	7800	6400	8700	7600	6200	
	MH – stabilizers up – solid tires						20,100	20,100	14,600	13,200	13,200	9800	9500	9500	7100	7300	7300	5400	5800	5800	4300	4700	4700	3400	4500	4500	3300	
	MH – stabilizers down – solid tires						*31,700	*31,700	*31,700	*23,300	*23,300	21,300	*18,500	*18,500	15,100	14,100	14,100	11,500	11,200	11,200	9100	9200	9200	7500	8800	8800	7200	
	Lower (std UC) – f. stabilizer & r. dozer up						19,900	18,500	14,000	13,000	12,200	9400	9300	8900	6800	7100	6800	5200	5600	5400	4000	4500	4300	3200	4400	4200	3100	
	Lower (std UC) – f. stabilizer & r. dozer down						*31,700	*31,700	22,400	*23,300	*23,300	14,500	17,800	17,400	10,400	13,400	13,100	8000	10,600	10,400	6300	8600	8500	5100	8300	8200	5000	
0 ft	Lower (std UC) – f. dozer & r. stabilizer up						20,600	17,900	14,000	13,400	11,800	9400	9700	8600	6800	7400	6500	5200	5800	5200	4000	4700	4200	3200	4600	4000	3100	
	Lower (std UC) – f. dozer & r. stabilizer down						*31,700	*31,700	23,200	*23,300	21,800	14,900	*18,500	15,300	10,700	15,000	11,600	8200	11,800	9200	6500	*9600	6700	5300	*8900	7200	5100	
	Lower (std UC) – 2 sets stabilizers up						20,400	18,400	14,100	13,300	12,200	9500	9600	8800	6900	7300	6700	5200	5800	5300	4100	4700	4300	3300	4500	4100	3100	
	Lower (std UC) – 2 sets stabilizers down						*31,700	*31,700	28,300	*23,300	22,300	17,800	18,300	15,700	12,700	13,700	11,900	9700	10,900	9400	7700	8900	7700	6300	8600	7500	6000	
	MH – stabilizers up – solid tires	*9200	*9200	*9200	18,500	18,500	13,200	12,300	12,300	9000	9100	9100	6700	7000	7000	5200	5600	5600	4100	4500	4500	3300	4400	4400	3200	4300	3300	
	MH – stabilizers down – solid tires	*9200	*9200	*9200	*31,700	*31,700	*31,700	*23,300	*23,300	20,400	*18,200	*18,200	14,500	13,800	13,800	11,200	11,000	11,000	8900	9000	9000	7500	8800	8800	7200	8500	8500	
-5 ft	Lower (std UC) – f. stabilizer & r. dozer up						17,400	16,100	11,800	11,500	10,800	8100	8500	8000	6000	6600	6300	4700	5300	5100	4000	4500	4300	3300	4400	4200	3100	
	Lower (std UC) – f. stabilizer & r. dozer down						*24,000	*24,000	19,800	*21,500	*21,500	13,100	*16,800	16,400	9600	12,800	12,600	7500	*10,100	*10,100	6000	8000	7800	5200	7500	7300	5100	
	Lower (std UC) – f. dozer & r. stabilizer up						18,000	15,500	11,800	12,000	10,400	8100	8800	7700	6000	6900	6000	4700	5500	4900	3800	4300	4100	3200	4200	3200	3100	
	Lower (std UC) – f. dozer & r. stabilizer down						*24,000	*24,000	20,600	*21,500	20,100	13,400	*16,800	14,300	9800	*13,200	11,000	7700	*10,100	*10,100	6900	8900	8700	5300	7800	7600	5200	
	Lower (std UC) – 2 sets stabilizers up						17,900	16,000	11,900	11,900	10,800	8200	8800	8000	6100	6800	6200	4700	5500	5000	3800	4300	4100	3200	4200	3200	3100	
	Lower (std UC) – 2 sets stabilizers down						*24,000	*24,000	24,000	*21,500	20,700	16,300	*16,800	14,800	11,800	13,200	11,400	9100	*10,100	9100	7400	8600	8400	5100	7600	7400	5100	

9

\*Limited by hydraulic rather than tipping load.

Lift capacity ratings are based on ISO 10567:2007, they do not exceed 87% of hydraulic lifting capacity or 75% of tipping load. The load point is the center line of the bucket pivot mounting pin on the stick. The oscillating axle must be locked. Lifting capacities are based on the machine standing on a firm uniform supporting surface. For lifting capacity including bucket and/or quick coupler, the respective weight has to be subtracted from above values. The use of a work tool attachment point to handle/lift objects, could affect the machine lift performance.

Always refer to the appropriate Operation and Maintenance Manual for specific product information.

**MH3037 Range Diagram**

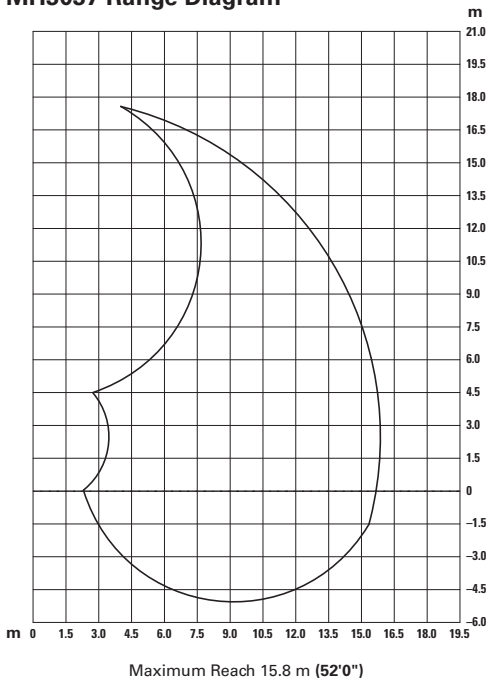

**MH3037 Specifications**

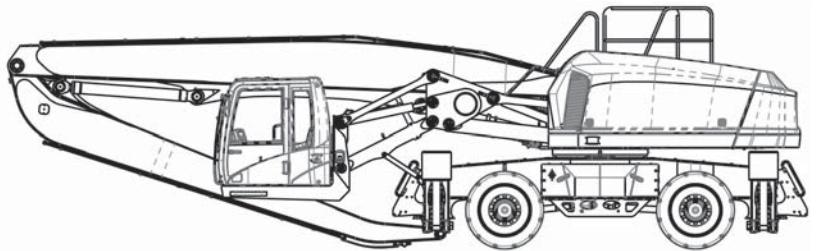
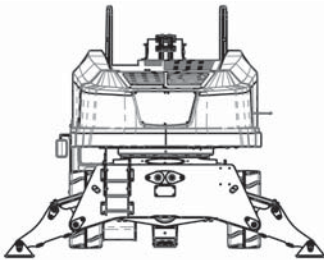

**Model**

**MH3037**

Operating Weight	37 420 kg	<b>82,500 lb</b>
Horsepower (Net)	168 kW	<b>225 hp</b>
Boom Length	8840 mm	<b>29'0"</b>
Stick Length	7417 mm	<b>24'4"</b>
Maximum Horizontal Reach	15 800 mm	<b>52'0"</b>
Maximum Vertical Pin Height	17 700 mm	<b>58'0"</b>
Maximum Depth	4900 mm	<b>16'0"</b>
Eye Level Height (Cab Fully Raised)	5500 mm	<b>18'0"</b>
Transport Width	3207 mm	<b>10'6"</b>
Transport Height	3334 mm	<b>10'11"</b>
Transport Length	12 560 mm	<b>41'2"</b>

**MH3037 Lift Capacities**

		3.0 m 10 ft	4.5 m 15 ft	6.0 m 20 ft	7.5 m 25 ft	9.0 m 30 ft	10.5 m 35 ft	12.0 m 40 ft	13.5 m 45 ft	15.0 m 50 ft	Maximum Reach		
												Lift	Distance
16.5 m 55.0 ft	kg lb												
15.0 m 50.0 ft	kg lb			8970									
13.5 m 45.0 ft	kg lb			8340 18,340	7290	6610							
12.0 m 40.0 ft	kg lb			17,660	7060 15,460	6360	5850						
10.5 m 35.0 ft	kg lb				7050 15,380	6310 13,770	5750 12,560						
9.0 m 30.0 ft	kg lb			8370 18,170	7230 15,710	6400 13,930	5770 12,560	5260 11,470					
7.5 m 25.0 ft	kg lb			8950 19,370	7570 16,420	6600 14,330	5870 12,750	5290 11,500	4780				
6.0 m 20.0 ft	kg lb	16 810 35,210	12 690 27,510	9780 21,140	8040 17,410	6870 14,890	6010 13,050	5350 11,610	4770 10,340		4570 10,120	14.0 m 45'10"	
4.5 m 15.0 ft	kg lb		14 660 31,550	10 730 23,180	8550 18,510	7150 15,500	6170 13,370	5410 11,730	4760 10,300		4400 9740	14.3 m 46'10"	
3.0 m 10.0 ft	kg lb		5470 13,620	11 500 24,850	8980 19,430	7390 16,010	6280 13,610	5440 11,780	4720 10,180		4250 9380	14.4 m 47'3"	
1.5 m 5.0 ft	kg lb		3610 8530	11 770 25,490	9180 19,880	7500 16,240	6310 13,670	5400 11,670	4600 9880		4060 8990	14.4 m 47'2"	
0.0 m 0.0 ft	kg lb		4130 9500	9700 22,660	9060 19,640	7410 16,040	6200 13,410	5240 11,300	4350 9280		3850 8530	14.2 m 46'6"	
-1.5 m -5.0 ft	kg lb			9550 22,000	8580 18,600	7070 15,290	5890 12,710	4900 10,520	3880				
-3.0 m -10.0 ft	kg lb				7720 16,700	6420 13,860	5320 11,430						
-4.5 m -15.0 ft	kg lb												

**Note:** Lift capacities are calculated with outriggers deployed.  
Rated loads do not exceed 87% of hydraulic lifting capacity or 75% of tipping capacity.  
Lifting capacities are calculated without worktool installed.

**MH3037 Lift Capacities**

		3.0 m 10 ft	4.5 m 15 ft	6.0 m 20 ft	7.5 m 25 ft	9.0 m 30 ft	10.5 m 35 ft	12.0 m 40 ft	13.5 m 45 ft	15.0 m 50 ft	Maximum Reach		
												Lift	Distance
16.5 m 55.0 ft	kg lb			7900 16,010									
15.0 m 50.0 ft	kg lb				6810 15,060	6190 11,950							
13.5 m 45.0 ft	kg lb				6440 14,170	5860 12,880	5430 11,980						
12.0 m 40.0 ft	kg lb					5710 12,510	5270 11,560	4930 10,820					
10.5 m 35.0 ft	kg lb					5700 12,440	5230 11,440	4850 10,610	4450				
9.0 m 30.0 ft	kg lb				6440 14,020	5800 12,640	5290 11,520	4860 10,600	4490 9800				
7.5 m 25.0 ft	kg lb				6770 14,710	6000 13,070	5410 11,780	4920 10,720	4510 9810				
6.0 m 20.0 ft	kg lb			8580 18,570	7260 15,730	6310 13,690	5590 12,150	5020 10,910	4540 9870	4100 8860	3800 8320	15.5 m 50'8"	
4.5 m 15.0 ft	kg lb	14 030 29,080	12 540 27,010	9590 20,730	7830 16,960	6650 14,420	5790 12,570	5130 11,140	4590 9950	4090 8820	3810 8370	15.7 m 51'7"	
3.0 m 10.0 ft	kg lb		14 620 31,530	10 590 22,900	8390 18,160	6970 15,110	5980 12,970	5230 11,330	4610 9990	4050 8710	3660 8080	15.9 m 52'0"	
1.5 m 5.0 ft	kg lb		6990 16,600	11 360 24,580	8800 19,060	7220 15,630	6110 13,240	5280 11,430	4600 9930	3950 8470	3510 7760	15.8 m 51'11"	
0.0 m 0.0 ft	kg lb	2150 4890	5220 12,220	11 580 25,070	9020 19,540	7310 15,820	6140 13,280	5240 11,330	4500 9690	3760 7990	3330 7380	15.7 m 51'4"	
-1.5 m -5.0 ft	kg lb	3110 7000	5380 12,200	10 530 24,380	8880 19,200	7190 15,560	6010 12,990	5080 10,960	5280 9170	3400 7060	3110 6860	15.4 m 50'4"	
-3.0 m -10.0 ft	kg lb		6030 16,640	10 110 22,590	8380 18,130	6880 14,740	5690 12,250	4740 10,180	3870 8190				
-4.5 m -15.0 ft	kg lb				7510 16,190	6210 13,360	5100 10,920						

**Note:** Lift capacities are calculated with outriggers deployed.  
 Rated loads do not exceed 87% of hydraulic lifting capacity or 75% of tipping capacity.  
 Lifting capacities are calculated without worktool installed.

**MH3049 Range Diagram**

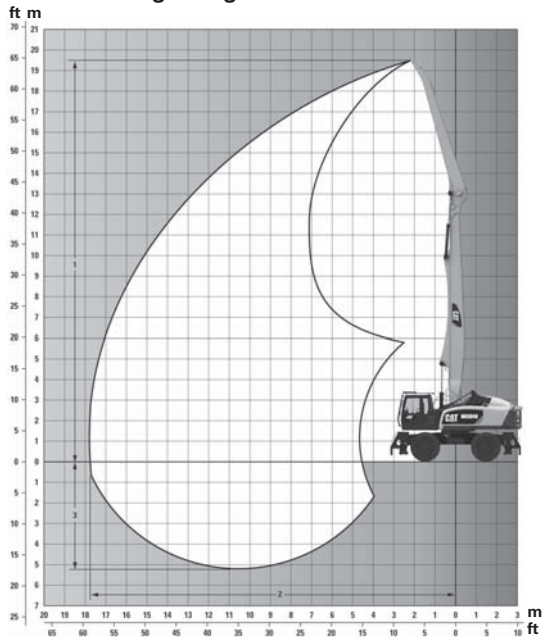

Maximum Reach 17.8 m (58'5")

**MH3049 Specifications**



Model	MH3049	
Operating Weight	50 349 kg	111,000 lb
Horsepower (Net)	224 kW	300 hp
Boom Length	10 668 mm	35'0"
Stick Length	8001 mm	26'3"
Maximum Horizontal Reach	17 805 mm	58'5"
Maximum Vertical Pin Height	19 507 mm	64'0"
Maximum Depth	5300 mm	17'4"
Eye Level Height (Cab Fully Raised)	5700 mm	18'8"
Transport Width	3321 mm	10'11"
Transport Height	3582 mm	11'9"
Transport Length	14 402 mm	47'3"



**MH3049 Lift Capacities**

		4.5 m 15 ft	6.0 m 20 ft	7.5 m 25 ft	9.0 m 30 ft	10.5 m 35 ft	12.0 m 40 ft	13.5 m 45 ft	15.0 m 50 ft	16.5 m 55 ft
18.0 m <b>60.0 ft</b>	kg lb			6400 <b>14,110</b>						
16.5 m <b>55.0 ft</b>	kg lb				6480 <b>14,290</b>	5100 <b>11,250</b>				
15.0 m <b>50.0 ft</b>	kg lb				7300 <b>16,090</b>	6420 <b>14,160</b>	<b>11,110</b>			
13.5 m <b>45.0 ft</b>	kg lb				7800 <b>17,190</b>	7000 <b>15,440</b>	6250 <b>13,780</b>	4660 <b>10,280</b>		
12.0 m <b>40.0 ft</b>	kg lb				7810 <b>17,230</b>	7130 <b>15,720</b>	6410 <b>14,130</b>	5800 <b>12,790</b>		
10.5 m <b>35.0 ft</b>	kg lb				8090 <b>17,840</b>	7790 <b>17,170</b>	7160 <b>15,780</b>	6150 <b>13,570</b>	5180 <b>11,430</b>	
9.0 m <b>30.0 ft</b>	kg lb			9370 <b>20,670</b>	8880 <b>19,590</b>	8140 <b>17,950</b>	7340 <b>16,180</b>	6530 <b>14,390</b>	5550 <b>12,230</b>	
7.5 m <b>25.0 ft</b>	kg lb		10 360 <b>22,840</b>	10 070 <b>22,200</b>	9500 <b>20,950</b>	8370 <b>18,460</b>	7480 <b>16,490</b>	6590 <b>14,520</b>	5770 <b>12,730</b>	4780 <b>10,530</b>
6.0 m <b>20.0 ft</b>	kg lb	12 350 <b>27,240</b>	12 780 <b>28,180</b>	11 700 <b>25,790</b>	9930 <b>21,900</b>	8640 <b>19,050</b>	7640 <b>16,850</b>	6650 <b>14,660</b>	5790 <b>12,770</b>	5060 <b>11,150</b>
4.5 m <b>15.0 ft</b>	kg lb	20 940 <b>46,180</b>	15 540 <b>34,260</b>	12 410 <b>27,370</b>	10 360 <b>22,840</b>	8900 <b>19,620</b>	7790 <b>17,180</b>	6700 <b>14,770</b>	5800 <b>12,780</b>	5170 <b>11,400</b>
3.0 m <b>10.0 ft</b>	kg lb	5020 <b>11,070</b>	16 540 <b>36,460</b>	12 990 <b>28,650</b>	10 710 <b>23,610</b>	9100 <b>20,070</b>	7900 <b>17,420</b>	6710 <b>14,800</b>	5760 <b>12,700</b>	5090 <b>11,220</b>
1.5 m <b>5.0 ft</b>	kg lb	2580 <b>5690</b>	8500 <b>18,740</b>	13 280 <b>29,280</b>	10 880 <b>24,000</b>	9190 <b>20,270</b>	7920 <b>17,470</b>	6670 <b>14,700</b>	5670 <b>12,510</b>	4950 <b>10,910</b>
0.0 m <b>0.0 ft</b>	kg lb	2540 <b>5600</b>	5960 <b>13,150</b>	13 170 <b>29,030</b>	10 820 <b>23,860</b>	9120 <b>20,110</b>	7820 <b>17,250</b>	6530 <b>14,400</b>	5500 <b>12,120</b>	4710 <b>10,390</b>
-1.5 m <b>-5.0 ft</b>	kg lb	3030 <b>6690</b>	5550 <b>12,230</b>	10 950 <b>24,150</b>	10 470 <b>23,090</b>	8840 <b>19,500</b>	7570 <b>16,680</b>	6050 <b>13,330</b>	5200 <b>11,470</b>	4340 <b>9570</b>
-3.0 m <b>-10.0 ft</b>	kg lb		5760 <b>12,710</b>	10 010 <b>22,070</b>	9800 <b>21,610</b>	8320 <b>18,350</b>	7100 <b>15,660</b>	5620 <b>12,390</b>	4740 <b>10,460</b>	
-4.5 m <b>-15.0 ft</b>	kg lb				8790 <b>19,370</b>	7500 <b>16,540</b>	6380 <b>14,070</b>			

**Note:** Lift capacities are calculated with outriggers deployed.  
 Rated loads do not exceed 87% of hydraulic lifting capacity or 75% of tipping capacity.

**MH3059 Range Diagram**

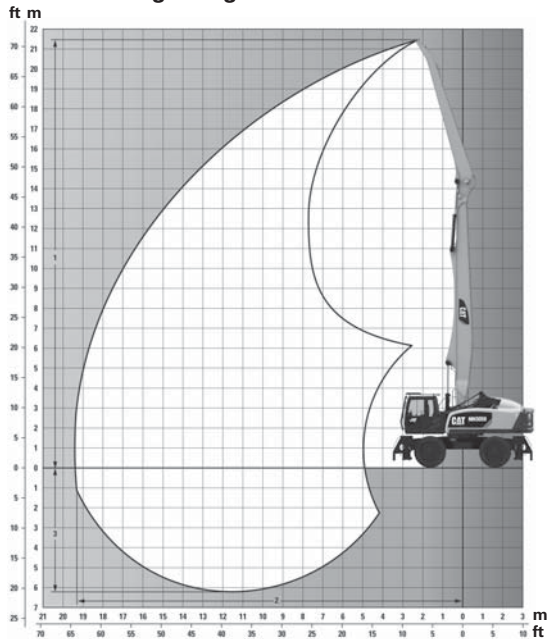

Maximum Reach 19.3 m (63'5")

**MH3059 Specifications**

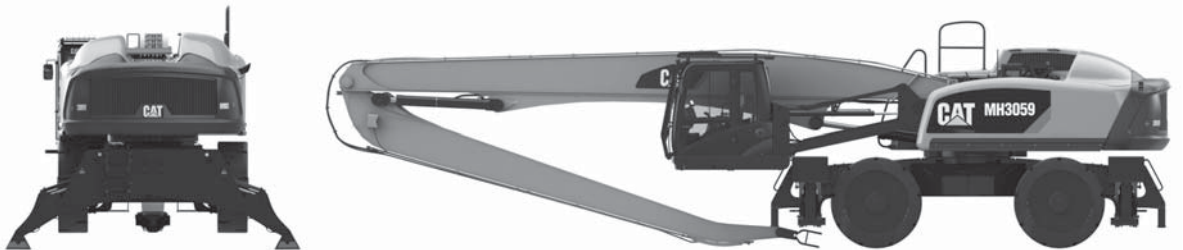

**Model**

**MH3059**

Operating Weight	58 967 kg	<b>130,000 lb</b>
Horsepower (Net)	242 kW	<b>325 hp</b>
Boom Length	10 795 mm	<b>35'5"</b>
Stick Length	8992 mm	<b>29'6"</b>
Maximum Horizontal Reach	19 324 mm	<b>63'5"</b>
Maximum Vertical Pin Height	21 463 mm	<b>70'5"</b>
Maximum Depth	6300 mm	<b>20'7"</b>
Eye Level Height (Cab Fully Raised)	7200 mm	<b>23'6"</b>
Transport Width	3632 mm	<b>11'11"</b>
Transport Height	4096 mm	<b>13'5"</b>
Transport Length	14 542 mm	<b>47'9"</b>

**MH3059 Lift Capacities**

		3.0 m 10 ft	4.5 m 15 ft	6.0 m 20 ft	7.5 m 25 ft	9.0 m 30 ft	10.5 m 35 ft	12.0 m 40 ft	13.5 m 45 ft	15.0 m 50 ft	16.5 m 55 ft	18.0 m 60 ft
19.5 m <b>65.0 ft</b>	kg lb				10 200 <b>22,490</b>	8340 <b>18,400</b>						
18.0 m <b>60.0 ft</b>	kg lb					8960 <b>19,760</b>	7660 <b>16,880</b>					
16.5 m <b>55.0 ft</b>	kg lb						8040 <b>17,720</b>	7160 <b>15,790</b>				
15.0 m <b>50.0 ft</b>	kg lb						7960 <b>17,560</b>	7520 <b>16,580</b>	6880 <b>15,170</b>			
13.5 m <b>45.0 ft</b>	kg lb						7870 <b>17,360</b>	7410 <b>16,350</b>	7030 <b>15,510</b>	6480 <b>14,290</b>		
12.0 m <b>40.0 ft</b>	kg lb						7940 <b>17,500</b>	7440 <b>16,400</b>	7020 <b>15,470</b>	6660 <b>14,690</b>	5960 <b>13,140</b>	
10.5 m <b>35.0 ft</b>	kg lb					8810 <b>19,430</b>	8140 <b>17,950</b>	7570 <b>16,700</b>	7090 <b>15,630</b>	6680 <b>14,730</b>	6220 <b>13,710</b>	
9.0 m <b>30.0 ft</b>	kg lb					9290 <b>20,480</b>	8480 <b>18,690</b>	7800 <b>17,210</b>	7220 <b>15,920</b>	6770 <b>14,930</b>	6360 <b>14,030</b>	5300 <b>11,690</b>
7.5 m <b>25.0 ft</b>	kg lb				10 800 <b>23,810</b>	9940 <b>21,920</b>	8930 <b>19,690</b>	8120 <b>17,910</b>	7460 <b>16,450</b>	6910 <b>15,230</b>	6440 <b>14,190</b>	5870 <b>12,940</b>
6.0 m <b>20.0 ft</b>	kg lb			13 490 <b>29,740</b>	12 440 <b>27,440</b>	10 740 <b>23,680</b>	9470 <b>20,890</b>	8500 <b>18,740</b>	7710 <b>17,010</b>	7070 <b>15,600</b>	6530 <b>14,400</b>	6000 <b>13,240</b>
4.5 m <b>15.0 ft</b>	kg lb		23 430 <b>51,670</b>	17 810 <b>39,270</b>	13 800 <b>30,430</b>	11 610 <b>25,610</b>	10 060 <b>22,190</b>	8900 <b>19,630</b>	7990 <b>17,620</b>	7260 <b>16,000</b>	6640 <b>14,640</b>	6000 <b>13,240</b>
3.0 m <b>10.0 ft</b>	kg lb		8130 <b>17,920</b>	20 000 <b>44,100</b>	15 120 <b>33,350</b>	12 470 <b>27,500</b>	10 640 <b>23,460</b>	9300 <b>20,500</b>	8260 <b>18,210</b>	7430 <b>16,380</b>	6730 <b>14,840</b>	6090 <b>13,430</b>
1.5 m <b>5.0 ft</b>	kg lb		3290 <b>7250</b>	12 260 <b>27,030</b>	16 210 <b>35,750</b>	13 200 <b>29,110</b>	11 140 <b>24,560</b>	9640 <b>21,250</b>	8490 <b>18,720</b>	7570 <b>16,690</b>	6780 <b>14,960</b>	6060 <b>13,360</b>
0.0 m <b>0.0 ft</b>	kg lb	890 <b>1980</b>	3070 <b>6770</b>	7750 <b>17,090</b>	16 920 <b>37,310</b>	13 720 <b>30,250</b>	11 510 <b>25,370</b>	9890 <b>21,800</b>	8640 <b>19,060</b>	7640 <b>16,850</b>	6780 <b>14,950</b>	5940 <b>13,100</b>
-1.5 m <b>-5.0 ft</b>	kg lb		3630 <b>8010</b>	7010 <b>15,460</b>	14 790 <b>32,620</b>	13 960 <b>30,790</b>	11 690 <b>25,770</b>	10 000 <b>22,050</b>	8680 <b>19,150</b>	7610 <b>16,780</b>	6670 <b>14,700</b>	5680 <b>12,530</b>
-3.0 m <b>-10.0 ft</b>	kg lb		4450 <b>9820</b>	7250 <b>15,990</b>	13 050 <b>28,780</b>	13 880 <b>30,610</b>	11 630 <b>25,650</b>	9930 <b>21,890</b>	8580 <b>18,910</b>	7440 <b>16,400</b>	6390 <b>14,090</b>	
-4.5 m <b>-15.0 ft</b>	kg lb				7900 <b>17,410</b>	12 880 <b>28,390</b>	13 440 <b>29,630</b>	11 300 <b>24,910</b>	9620 <b>21,220</b>	8250 <b>18,200</b>	7050 <b>15,550</b>	
-6.0 m <b>-20.0 ft</b>	kg lb						12 580 <b>27,730</b>	10 610 <b>23,400</b>	9010 <b>19,860</b>			

**Note:** Lift capacities are calculated with outriggers deployed.  
 Rated loads do not exceed 87% of hydraulic lifting capacity or 75% of tipping capacity.

385C MH Range Diagrams

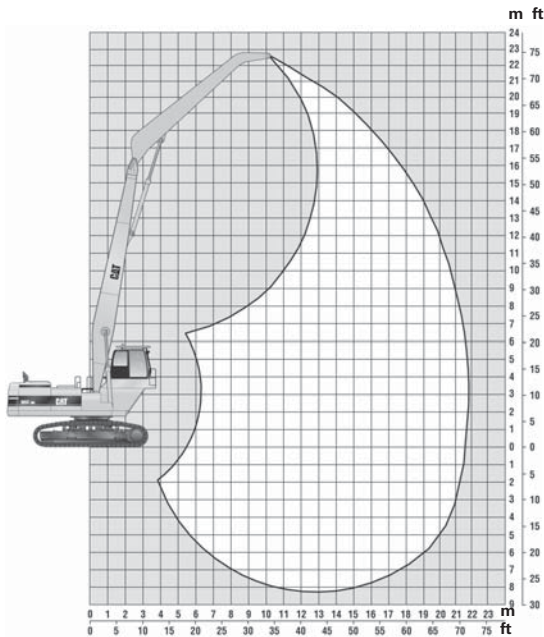

Maximum Reach 21.8 m (71'6")

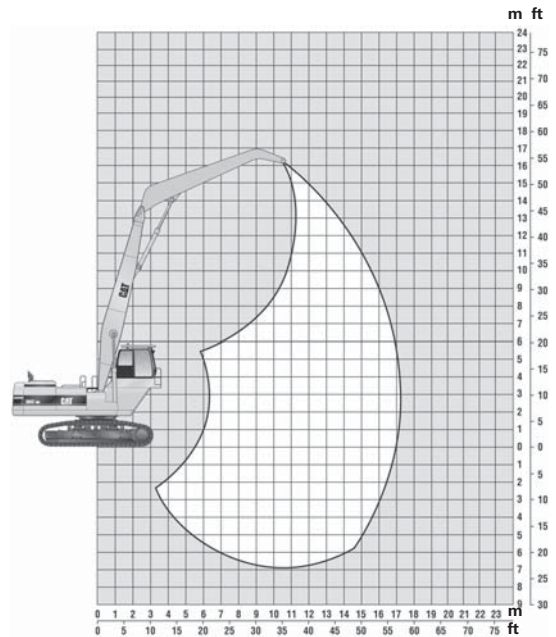

Maximum Reach 17.2 m (56'6")

385C MH Specifications

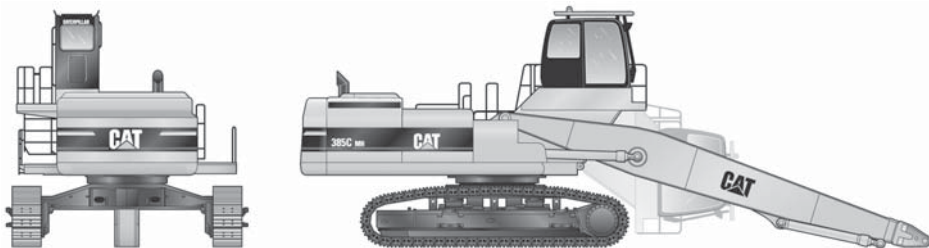

Model	385C MH			
	Long Front		Short Front	
Overall Weight	92.6 t	204,200 lb	92.6 t	204,200 lb
Horsepower (Net)	382 kW	513 hp	382 kW	513 hp
Maximum Horizontal Reach	21.8 m	71'6"	17.2 m	56'6"
Maximum Vertical Pin Height	22.6 m	74'2"	16.3 m	53'3"

**Lift Capacities**

385C MH — 21.8 m (71.5') Front

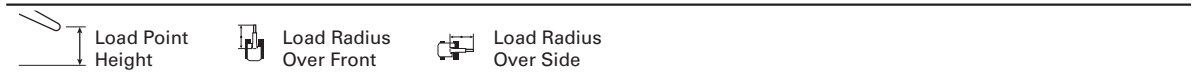

Load Point Height	4.5 m/15.0 ft		6.0 m/20.0 ft		9.0 m/30.0 ft		12.0 m/40.0 ft		13.5 m/45.0 ft		15.0 m/50.0 ft		18.0 m/60.0 ft		19.5 m/65.0 ft		21.0 m/70.0 ft		Load at Maximum Reach			
	kg	lb	kg	lb	kg	lb	kg	lb	kg	lb	kg	lb	kg	lb	kg	lb	kg	lb	kg	lb	m	ft
21.0 m 70.0 ft							*9980	*9980												*9600	*9600	12.18
19.5 m 65.0 ft									*10 120	*10 120										*21,738	*21,738	38.3
18.0 m 60.0 ft							*25,662	*25,662												*8750	*8750	14.17
16.5 m 55.0 ft									*12 060	*12 060	*9860	*9860								*19,621	*19,621	45.3
15.0 m 50.0 ft									*25,309	*25,309	*19,577	*19,577								*8210	*8210	15.77
13.5 m 45.0 ft									*13 270	*13 270	*11 730	*11 730								*18,276	*18,276	50.8
12.0 m 40.0 ft									*28,572	*28,572	*24,471	*24,471								*7830	*7830	17.08
10.5 m 35.0 ft									*13 230	*13 230	*12 190	*12 190	*8070	*8070						*17,394	*17,394	55.3
9.0 m 30.0 ft									*28,814	*28,814	*26,544	*26,544								*7580	*7580	18.17
7.5 m 25.0 ft									*13 280	*13 280	*12 200	*12 200	*10 120	*10 120						*16,777	*16,777	59.1
6.0 m 20.0 ft									*28,881	*28,881	*26,544	*26,544	*20,349	*20,349						*7410	*7410	19.09
4.5 m 15.0 ft									*13 400	*13 400	*12 270	*12 270	*10 090	*10 090	*8350	*8350				*16,380	*16,380	62.2
3.0 m 10.0 ft									*29,123	*29,123	*26,654	*26,654	21,936	21,936						*7300	*7300	19.84
1.5 m 5.0 ft									*15 010	*15 010	*13 580	*12 370	9970	9970	8460	8460				*16,116	*16,116	64.8
0.0 m 0.0 ft									*32,584	*32,584	*29,476	*26,852	21,716	21,716	18,327	18,327	7200	7040		*7250	*7250	20.46
-1.5 m -5.0 ft									*15 350	*15 350	*13 800	*13 800	9970	9780	8520	8350				*16,006	*16,006	66.6
-3.0 m -10.0 ft									*33,290	*33,290	*29,939	*29,939	21,363	20,966	18,210	17,835				*7250	*7250	20.46
-4.5 m -15.0 ft									*20 620	*20 620	*15 710	*14 030	9740	9560	8370	8200	7200	7040		*15,984	*15,984	68.6
-6.0 m -20.0 ft									*44,644	*44,644	*34,061	*34,061	20,900	20,503	17,902	17,549				6970	6820	21.32
-7.5 m -25.0 ft									*21 490	*21 490	*16 070	*14 240	9490	9300	8190	8030	7090	6940		15,410	15,080	69.8
									*46,495	*46,495	*34,811	*30,865	20,371	19,974	17,549	17,196	15,146	14,815		14,815	14,815	70.7
									*22 210	*22 210	*16 350	*14 410	9220	9030	8000	7830	6970	6820		6820	6520	71.3
									*48,083	*48,083	*35,406	*31,217	19,798	19,401	17,152	16,799	14,925	14,595		14,595	14,396	71.3
									*22 650	*22 650	*16 500	*14 110	8950	8770	7810	7640	6850	6690		6410	6260	21.78
									*49,053	*49,053	*35,737	*31,217	19,224	18,827	16,755	16,402	14,683	14,330		14,132	13,801	71.5
									*22 650	*22 650	16 030	15 730	8700	8510	7630	7460	6730	6580		6350	6210	21.72
									*49,097	*49,097	34,568	33,907	18,695	18,298	16,380	16,028	14,440	14,110		13,999	13,691	71.3
									*22 170	*22 170	15 350	15 040	8470	8290	7470	7300	6640	6480		6370	6220	21.56
									*48,083	*48,083	33,091	32,430	18,232	17,835	16,050	15,697	14,264	13,933		14,043	13,713	70.7
									*6740	*6740	*20 990	14 810	8290	8100	7350	7180	6570	6420		*6240	*6240	21.29
									*15,432	*15,432	*45,988	31,923	17,835	17,439	15,807	15,432				*13,735	*13,735	69.8
									*7830	*7830	*19 360	14 420	8160	7970	7270	7100				*5750	*5750	20.91
									*17,813	*17,813	*42,858	31,085	17,571	17,174	*15,410	15,300				*12,632	*12,632	68.5
									*9060	*9060	*17 890	*13 750	7800	7800	*6310	*6310				*5160	*5160	20.41
									*20,503	*20,503	*38,735	*29,674	*16,491	*16,491	*12,985	*12,985				*11,310	*11,310	66.9
									*15 580	*15 580	*12 270	*12 270	*9370	*9370	*6590	*6590						
									*33,643	*33,643	*26,367	*23,082	*19,996	*19,996	*13,691							
									*10 390	*10 390	*9120	*7830										
									*22,179	*22,179	*19,357	*19,357	*16,491	*16,491								

\*Rated by hydraulic capacity rather than stability capacity. The use of a work tool attachment point to handle/lift objects, could affect the machine lift performance. Always refer to the appropriate Operation and Maintenance Manual for specific product information.

Lift Capacities

385C MH — 17.2 m (56.5') Front

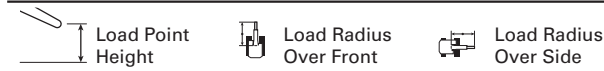

Load Point Height	4.5 m/15.0 ft		6.0 m/20.0 ft		7.5 m/25.0 ft		9.0 m/30.0 ft		10.5 m/35.0 ft		12.0 m/40.0 ft		13.5 m/45.0 ft		15.0 m/50.0 ft		16.5 m/55.0 ft		Load at Maximum Reach													
	kg	lb	kg	lb	kg	lb	kg	lb	kg	lb	kg	lb	kg	lb	kg	lb	kg	lb	kg	lb	kg	lb	m	ft								
15.0 m 50.0 ft												*13 430	*13 430									*13 020	*13 020	12.32								
13.5 m 45.0 ft												*14 520	*14 520	*12 830	*12 830							*12 620	*12 620	13.64								
12.0 m 40.0 ft												*15 450	*15 450	*14 150	*14 150							*12 430	*12 430	14.68								
10.5 m 35.0 ft												*16 470	*16 470	*15 350	*15 350	*13 350	*13 350					*12 400	*12 400	15.5								
9.0 m 30.0 ft												*18 040	*18 040	*16 870	*16 870	*15 570	*15 570	14 290	14 060			*12 510	*12 390	16.15								
7.5 m 25.0 ft												*19 190	*19 190	*17 370	*17 370	*15 860	*15 860	14 100	13 870	12 030	11 820	11 870	11 670	16.63								
6.0 m 20.0 ft												*42,439	*42,439	*41,689	*41,689	*37,743	*37,743	*34,480	*34,480	30,314	29,829	26,279	25,838	54.4								
4.5 m 15.0 ft												*21 860	*21 860	*22 850	*22 850	*20 050	*20 050	*17 910	*16 120	13 860	13 640	11 880	11 680	11 350	11 150	16.96						
3.0 m 10.0 ft												*47,642	*47,642	*49,516	*49,516	*43,497	*43,497	*38,890	*35,164	34,701	29,829	29,344	25,530	25,089	25,089	24,648	55.6					
1.5 m 5.0 ft												*28 870	*28 870	*24 190	*24 190	*20 900	*20 900	*18 440	*18 440	16 000	15 740	13 600	13 370	11 710	11 500	11 000	10 800	17.15				
0.0 m 0.0 ft												*62,457	*62,457	*52,404	*52,404	*45,327	*45,327	*40,014	*40,014	34,458	33,907	29,277	28,792	25,177	24,736	24,273	23,854	56.3				
-1.5 m -5.0 ft												*30 670	*30 670	*25 310	*25 310	*21 600	*21 600	18 590	18 290	15 610	15 350	13 330	13 100	11 530	11 320	10 800	10 600	17.22				
-3.0 m -10.0 ft												*66,381	*66,381	*54,829	*54,829	*46,826	*46,826	40,080	39,419	33,643	33,069	28,704	28,219	24,802	24,361	23,810	23,391	56.5				
-4.5 m -15.0 ft												*31 670	*31 670	*25 990	*25 990	21 920	21 570	18 080	17 780	15 250	14 990	13 080	12 850	11 360	11 160	10 730	10 530	17.14				
-6.0 m -20.0 ft												*68,608	*68,608	*56,306	*56,306	47,267	46,495	38,978	38,316	32,871	32,298	28,175	27,668	24,471	24,030	23,656	23,215	56.3				
-7.5 m -25.0 ft												*7550	*7550	*21 560	*21 560	*26 070	*26 070	21 310	20 960	17 640	17 340	14 940	14 680	12 860	12 630	11 220	11 010	10 810	10 610	16.94		
-9.0 m -30.0 ft												*17,835	*17,835	*52,051	*52,051	*56,504	56,328	45,944	45,173	38,030	37,390	32,187	31,636	27,712	27,205	24,163	23,722	23,832	23,391	55.6		
-10.5 m -35.0 ft												*3750	*3750	*8380	*8380	*18 230	*18 230	*25 460	*25 460	20 850	20 500	17 300	17 000	14 690	14 430	12 690	12 460	11 120	10 910	11 030	10 830	16.59
-12.0 m -40.0 ft												*8,686	*8,686	*19,445	*19,445	*42,924	*42,924	*55,182	55,005	44,952	44,181	37,302	36,641	31,658	31,107	27,359	26,852	24,339	23,898	54.4		
-13.5 m -45.0 ft												*5810	*5810	*9930	*9930	*18 130	*18 130	*24 130	*24 130	*20 540	*20 190	17 070	16 770	14 520	14 260	12 580	12 350			*11 310	11 240	16.1
-15.0 m -50.0 ft												*13,294	*13,294	*22,818	*22,818	*42,219	*42,219	*52,228	*52,228	44,291	43,519	36,795	36,156	31,328	30,754	27,139	26,654			*24,890	24,802	52.8
-16.5 m -55.0 ft												*11 830	*11 830	*19 400	*19 400	*22 040	*22 040	*18 880	*18 880	*16 190	*16 190	*13 790	*13 790	*11 440	*11 440			*10 700	*10 700	15.44		
-18.0 m -60.0 ft												*27,051	*27,051	*44,930	*44,930	*47,598	*47,598	*40,697	*40,697	*34,789	*34,789	*29,476	*29,476	*24,119	*24,119			*23,501	*23,501	50.5		
-19.5 m -65.0 ft												*21 590	*21 590	*19 120	*19 120	*16 470	*16 470	*14 040	*14 040	*11 670	*11 670											
-21.0 m -70.0 ft												*47,443	*47,443	*41,094	*41,094	*35,296	*35,296	*29,917	*29,917	*24,604	*24,604											

\*Rated by hydraulic capacity rather than stability capacity. The use of a work tool attachment point to handle/lift objects, could affect the machine lift performance. Always refer to the appropriate Operation and Maintenance Manual for specific product information.

**MAGNET SELECTION GUIDE**

Cat MH Model	Gen. Required (kW)	Recommended Magnet Size (Diameter)					
		1219 mm (48")	1448 mm (57")	1676 mm (66")	1829 mm (72")	1981 mm (78")	2210 mm (87")
M322D2 MH	11.0 m (36'1") Front	X	X				
M324D2 MH	12.5 m (40'11") Front		X				
M325D MH	15.6 m (51'4") Front		X				
M325D MH	14.3 m (47'0") Front		X				
M325D LMH	15.6 m (51'4") Front		X				
M325D LMH	14.3 m (47'0") Front			X			
MH3022	11.0 m (36'1") Front	X	X				
MH3024	12.5 m (40'11") Front		X				
MH3037	14.4 m (47'4") Front		X	X			
MH3037	15.8 m (52'0") Front	X	X				
MH3049	17.8 m (58'5") Front			X			
MH3059	19.3 m (63'5") Front			X	X		
385C MH	21.8 m (71'6") Front				X		
385C MH	17.2 m (56'6") Front						X

**GRAPPLE SELECTION GUIDE**

Cat MH Model	Gen. Required (kW)	Recommended Orange Peel Grapple Size — m <sup>3</sup> /(yd <sup>3</sup> )								
		0.60 (0.75)	0.76 (1.00)	0.95 (1.25)	1.14 (1.50)	1.5 (2.00)	1.0 (2.50)	2.3 (3.00)	3.0 (4.00)	3.8 (5.00)
M322D2 MH	11.0 m (36'1") Front	X								
M324D2 MH	12.5 m (40'11") Front		X							
M325D MH	15.6 m (51'4") Front	X								
M325D MH	14.3 m (47'0") Front		X							
M325D LMH	15.6 m (51'4") Front		X							
M325D LMH	14.3 m (47'0") Front			X						
MH3022	11.0 m (36'1") Front	X								
MH3024	12.5 m (40'11") Front		X							
MH3037	14.4 m (47'4") Front		X	X						
MH3037	15.8 m (52'0") Front		X	X						
MH3049	17.8 m (58'5") Front		X	X	X					
MH3059	19.3 m (63'5") Front				X	X	X			
385C MH	21.8 m (71'6") Front							X		
385C MH	17.2 m (56'6") Front									X

Grapple size must be matched to the machine size, linkage configuration and considering material density. For material density in the 1200 kg/m<sup>3</sup> (2000 lb/yd<sup>3</sup>) range the grapple in the table above can be used. For different material densities, please contact your Cat dealer for other grapple options.

**INSTITUTE OF SCRAP RECYCLING INDUSTRIES INC.**

**Scrap Specifications  
Guidelines for Ferrous Scrap**

**ISRI**

**Code Definition**

- 200 **No. 1 heavy melting steel.** Wrought iron and/or steel scrap 6.35 mm (1/4 in) and over in thickness. Individual pieces not over 1524 × 610 mm (60 × 24 in) (charging box size) prepared in a manner to insure compact charging.
- 203 **No. 2 heavy melting steel.** Wrought iron and steel scrap, black and galvanized, 3.18 mm (1/8 in) and over in thickness, charging box size to include material not suitable as No. 1 heavy melting steel. Prepared in a manner to insure compact charging.
- 207 **No. 1 busheling.** Clean steel scrap, not exceeding 305 mm (12 in) in any dimensions, including new factory busheling (for example, sheet clippings, stampings, etc.). May not include old auto body and fender stock. Free of metal coated, limed, vitreous enameled, and electrical sheet containing over 0.5 percent silicon.
- 208 **No. 1 bundles.** New black steel sheet scrap, clippings or skeleton scrap, compressed or hand bundled, to charging box size, and weighing not less than 34 kg (75 lb) per cubic foot. (Hand bundles are tightly secured for handling with a magnet.) May include Stanley balls or mandrel wound bundles or skeleton reels, tightly secured. May include chemically detinned material. May not include old auto body or fender stock. Free of metal coated, limed, vitreous enameled, and electrical sheet containing over 0.5 percent silicon.
- 209 **No. 2 bundles.** Old black and galvanized steel sheet scrap, hydraulically compressed to charging box size and weighing not less than 34 kg (75 lb) per cubic foot. May not include tin or lead-coated material of vitreous enameled material.
- 210 **Shredded Scrap.** Homogeneous iron and steel scrap magnetically separated, originating from automobiles, unprepared No. 1 and No. 2 steel, miscellaneous baling and sheet scrap. Average density 23 kg (50 lb) per cubic foot.
- 211 **Shredded Scrap.** Homogeneous iron and steel scrap magnetically separated, originating from automobiles, unprepared No. 1 and No. 2 steel, miscellaneous baling and sheet scrap. Average density 34 kg (70 lb) per cubic foot.
- 219 **Machine shop turnings.** Clean steel or wrought iron turnings, free of iron borings, nonferrous metals in a free state, scale, or excessive oil. May not include badly rusted or corroded stock.
- 231 **Plate and structural steel, 1.5 m (5 ft) and under.** Cut structural and plate scrap, 1.5 m (5 ft) and under. Clean open hearth steel plates, structural shapes, crop ends, shearings, or broken steel tires. Dimensions not less than 6.35 mm (1/4 in) thickness, not over 1.5 m (5 ft) in length and 457 mm (18 in) in width. Phosphorous or sulphur not over 0.05 percent.
- 234 **Punchings and plate scrap.** Punchings or stampings, plate scrap, and bar crops containing not over 0.05 percent phosphorous or sulphur and not over 0.5 percent silicon, free from alloys. All materials cut 305 mm (12 in) and under, and with the exception of punchings or stampings, at least 3.18 mm (1/8 in) in thickness. Punchings or stampings under 152 mm (6 in) in diameter may be any gauge.





# MINING & OFF-HIGHWAY TRUCKS

## CONTENTS

Features . . . . .	10-2		
Truck Specifications . . . . .	10-4		
Tire Specifications . . . . .	10-19		
Use of Brake Performance Curves . . . . .	10-20		
Fixed Times for Hauling Units . . . . .	10-20		
Mechanical Power Train Efficiencies . . . . .	10-21		
		Curves:	
		770G Rimpull-Speed-Gradeability, Brake Performance . . . . .	10-22
		772G Rimpull-Speed-Gradeability, Brake Performance . . . . .	10-28
		773E Rimpull-Speed-Gradeability, Brake Performance . . . . .	10-34
		773G Rimpull-Speed-Gradeability, Brake Performance . . . . .	10-37
		775G Rimpull-Speed-Gradeability, Brake Performance . . . . .	10-43
		777E Rimpull-Speed-Gradeability, Brake Performance . . . . .	10-49
		777G Rimpull-Speed-Gradeability, Brake Performance . . . . .	10-52
		785C Rimpull-Speed-Gradeability, Brake Performance . . . . .	10-58
		785D Rimpull-Speed-Gradeability, Brake Performance . . . . .	10-61
		789D Rimpull-Speed-Gradeability, Brake Performance . . . . .	10-64
		793D Rimpull-Speed-Gradeability, Brake Performance . . . . .	10-68
		793F Rimpull-Speed-Gradeability, Brake Performance . . . . .	10-73
		794 AC Rimpull-Speed-Gradeability, Brake Performance . . . . .	10-78
		795F AC Rimpull-Speed-Gradeability, Brake Performance . . . . .	10-80
		797F Rimpull-Speed-Gradeability, Brake Performance . . . . .	10-82

**Features:**

- **Cat® Four-Stroke Diesel Engines** — Turbocharged, after-cooled, adjustment-free fuel system (direct injection).
- **Electronically-Controlled Automatic Transmission** — Speed sensing device automatically shifts transmission between 1st and gear selected by operator.
- **Truck Production Management System (TPMS)** — Utilizes strut pressure sensors and an on-board micro-processor to determine payload weight, cycle segment times, delay times, actual clock time and date of each cycle.
- **VIMSTM** — Monitors all vital machine functions. Keeps operator informed of current machine operating conditions, helps reduce downtime and allows service personnel easy access to data for fast accurate diagnosis. VIMS includes the Truck Production Management System.
- **Mechanical Electronic Unit Injection (MEUITM)** in the 770 through 793D — Electronically maintains fuel settings, provides automatic altitude and air filter restriction compensation, and features automatic variable timing, improved diagnostics and increased fuel efficiency.
- **Common Rail Fuel System** — in the C175 engines are used on (793F, 794 AC, 795F AC, and 797F) trucks.
- **Oil Cooled Disc Brakes** — Provide retarding, service, parking, and secondary braking in a single sealed, fade-resistant, maintenance-free unit. Standard on the 770 through 775G and 777E, front brakes are caliper disc and can be switched out of the service system when not needed but activate as part of the secondary system. Standard on the 777G through 797F, front brakes are oil-cooled disc, providing excellent control in slippery conditions.
- **Automatic Retarder Control (ARC)** — Electronically controls braking on grade to maintain optimal engine RPM and oil cooling. ARC benefits include engine overspeed protection, ease of operation, faster downhill speeds, smoother ride and better control in slippery conditions.
- **Traction Control System (TCS)** — Electronically monitors and controls rear wheel slippage for greater traction and enhanced truck performance in poor underfoot conditions. If slippage exceeds a set limit, the oil-cooled disc brakes engage to slow the spinning wheel. Torque is then automatically transferred to the wheel with better traction. Available on the 770 through 797F.
- **Full Hydraulic Steering** — Functions with front suspension cylinders serving as kingpins.
- **Suspension Cylinders** — Four independent, self-contained, nitrogen/oil-pneumatic suspension cylinders absorb loading and road shocks. Wide spacing for stability.
- **Truck Bodies** — A variety of truck bodies are available to meet your application specific requirements. Those options include MSDII (mine specific design), X, HE, HP, dual slope and gateless coal bodies. The Caterpillar body program ensures the truck is configured for an optimal haulage solution.
- **Integral Roll Over Protective Structure (ROPS)** — Integral Four-Post ROPS cab standard on all models. Resiliently mounted to the main frame to reduce vibration and sound, the integral ROPS structure is designed as an extension of the truck frame. The ROPS/FOPS structure provides “five sided protection” for the operator and trainer.
- **Separate Hydraulic Systems** — Prevent cross contamination.
- **Safety** — Caterpillar continues to be proactive in developing construction and mining trucks that meet or exceed industry standards. Safety is an integral part of the machine design.

An example of enhanced safety through the development of products, processes and solutions includes Cat Integrated Object Detection System which is an integrated camera and radar technology. More information on Object Detection is available in the technology section.

**NOTE:** Not all features are available on all models at this time.

**Sustainability:**

A variety of features improve sustainability in areas of decreasing waste, extending component life and lowering emissions levels. The 777G, 785D and 797F trucks offer Oil Renewal systems. The 777G, 785D, 793F, 797F trucks offer Continuous Rear Axle Filtration, Extended Life Filters and Extended maintenance intervals which aid in decreasing the amount of waste contributed to our environment.

- **Engines with advanced technology** contribute less emissions to the environment while maintaining fuel efficiency.
- **Advanced Surface Technology (AST)** is a replacement for hard chrome coatings on some steel parts, including Suspension and hoist Cylinder Rods.
- **Other features on 793F, 797F Mining trucks** include rear axle oil savers, front wheel sight glass, two piece cover on the final drive, ecology drains and brake wear indicators all of which help to maximize component life.

**NOTE:** Not all features are available on all models at this time.

**Non-Dumper Offerings:**

For certain applications the Caterpillar OEM Solution Group offers non-dumper arrangements for the 770G, 772G, 773G, 775G, 777G and 785D.

Non-dumper arrangements include a water truck and tractor configuration. For updates on additional offerings please contact Caterpillar OEM Solutions Group.

**NOTE:** Listed features may be standard on some models. Optional on others. Contact your Cat dealer for specific information.

MODEL	770G		770G		770G	
Body Type	Flat Floor		Quarry Body		Dual Slope	
Emission Standards	Tier 4 Final****		Tier 4 Final****		Tier 4 Final****	
Gross Machine Weight	71 214 kg	<b>157,000 lb</b>	71 214 kg	<b>157,000 lb</b>	71 214 kg	<b>157,000 lb</b>
Chassis Weight*	25 466 kg	<b>56,144 lb</b>	25 466 kg	<b>56,144 lb</b>	25 466 kg	<b>56,144 lb</b>
Body Weight	7953 kg	<b>17,533 lb</b>	10 095 kg	<b>22,256 lb</b>	7758 kg	<b>17,103 lb</b>
Payload Without Liner	37 795 kg	<b>83,323 lb</b>	35 652 kg	<b>78,600 lb</b>	37 990 kg	<b>83,753 lb</b>
Standard Liner Weight	2943 kg	<b>6488 lb</b>	—		2810 kg	<b>6195 lb</b>
Target Payload**	34 852 kg	<b>76,835 lb</b>	—		35 180 kg	<b>77,558 lb</b>
Capacity:						
Struck (SAE)	17.2 m <sup>3</sup>	<b>22.52 yd<sup>3</sup></b>	17.2 m <sup>3</sup>	<b>22.52 yd<sup>3</sup></b>	18 m <sup>3</sup>	<b>23.5 yd<sup>3</sup></b>
Heaped (2:1) (SAE)	25.1 m <sup>3</sup>	<b>32.8 yd<sup>3</sup></b>	25.1 m <sup>3</sup>	<b>32.8 yd<sup>3</sup></b>	25.9 m <sup>3</sup>	<b>33.9 yd<sup>3</sup></b>
Distribution Empty:						
Front		<b>51%</b>		<b>51%</b>		<b>51%</b>
Rear		<b>49%</b>		<b>49%</b>		<b>49%</b>
Distribution Loaded:						
Front		<b>34%</b>		<b>34%</b>		<b>34%</b>
Rear		<b>66%</b>		<b>66%</b>		<b>66%</b>
Engine Model	<b>C15 ACERT™</b>		<b>C15 ACERT</b>		<b>C15 ACERT</b>	
Number of Cylinders	<b>6</b>		<b>6</b>		<b>6</b>	
Bore	137 mm	<b>5.4"</b>	137 mm	<b>5.4"</b>	137 mm	<b>5.4"</b>
Stroke	171 mm	<b>6.7"</b>	171 mm	<b>6.7"</b>	171 mm	<b>6.7"</b>
Displacement	15 L	<b>928 in<sup>3</sup></b>	15 L	<b>928 in<sup>3</sup></b>	15 L	<b>928 in<sup>3</sup></b>
Net Power	356 kW	<b>477 hp</b>	356 kW	<b>477 hp</b>	356 kW	<b>477 hp</b>
Gross Power	384 kW	<b>515 hp</b>	384 kW	<b>515 hp</b>	384 kW	<b>515 hp</b>
Standard Tires	<b>18.00R33 (E4)</b>		<b>18.00R33 (E4)</b>		<b>18.00R33 (E4)</b>	
Machine Clearance Turning Circle	20.30 m	<b>66'6"</b>	20.30 m	<b>66'6"</b>	20.30 m	<b>66'6"</b>
Fuel Tank Refill Capacity	529 L	<b>140 U.S. gal</b>	529 L	<b>140 U.S. gal</b>	529 L	<b>140 U.S. gal</b>
Diesel Exhaust Fluid Refill Capacity	21 L	<b>6 U.S. gal</b>	21 L	<b>6 U.S. gal</b>	21 L	<b>6 U.S. gal</b>
Top Speed (Loaded)	73.5 km/h	<b>45.7 mph</b>	73.5 km/h	<b>45.7 mph</b>	73.5 km/h	<b>45.7 mph</b>
<b>GENERAL DIMENSIONS (Empty):</b>						
Height to Canopy Rock Guard Rail	4.21 m	<b>13'10"</b>	4.21 m	<b>13'10"</b>	4.21 m	<b>13'10"</b>
Wheelbase	3.96 m	<b>13'0"</b>	3.96 m	<b>13'0"</b>	3.96 m	<b>13'0"</b>
Overall Length (Operating)	8.80 m	<b>28'10"</b>	8.80 m	<b>28'10"</b>	8.80 m	<b>28'10"</b>
Overall Length (Shipping)	8.80 m	<b>28'10"</b>	8.80 m	<b>28'10"</b>	8.80 m	<b>28'10"</b>
Loading Height (Empty)	3.23 m	<b>10'7"</b>	3.23 m	<b>10'7"</b>	3.23 m	<b>10'7"</b>
Height at Full Dump	8.28 m	<b>27'2"</b>	8.28 m	<b>27'2"</b>	8.28 m	<b>27'2"</b>
Body Length (Target Length)	5.64 m	<b>18'6"</b>	5.64 m	<b>18'6"</b>	5.65 m	<b>18'6"</b>
Width (Operating)	4.78 m	<b>15'8"</b>	4.78 m	<b>15'8"</b>	4.78 m	<b>15'8"</b>
Width (Shipping)***	3.95 m	<b>13'0"</b>	3.95 m	<b>13'0"</b>	3.95 m	<b>13'0"</b>
Front Tire Tread	3.11 m	<b>10'3"</b>	3.11 m	<b>10'3"</b>	3.11 m	<b>10'3"</b>

\*Weights include lubricants, coolants and 100% fuel.

\*\*Refer to Caterpillar's 10/10/20 Payload Policy for Off-Highway Trucks.

\*\*\*Disassembled.

\*\*\*\*Meets U.S. EPA Tier 4 Final, EU Stage IV, and Japan 2014 (Tier 4 Final) emission standards.

MODEL	770G		770G		770G	
Body Type	Flat Floor		Quarry Body		Dual Slope	
Emission Standards	Tier 3 Equivalent and Tier 2 Equivalent****		Tier 3 Equivalent and Tier 2 Equivalent****		Tier 3 Equivalent and Tier 2 Equivalent****	
Gross Machine Weight	71 214 kg	<b>157,000 lb</b>	71 214 kg	<b>157,000 lb</b>	71 214 kg	<b>157,000 lb</b>
Chassis Weight*	24 900 kg	<b>54,895 lb</b>	24 900 kg	<b>54,895 lb</b>	24 900 kg	<b>54,895 lb</b>
Body Weight	7850 kg	<b>17,306 lb</b>	10 095 kg	<b>22,255 lb</b>	7665 kg	<b>16,898 lb</b>
Payload Without Liner	38 464 kg	<b>84,799 lb</b>	36 219 kg	<b>79,850 lb</b>	38 649 kg	<b>85,207 lb</b>
Standard Liner Weight	2940 kg	<b>6482 lb</b>	—		2895 kg	<b>6382 lb</b>
Target Payload**	35 524 kg	<b>78,318 lb</b>	—		35 754 kg	<b>78,825 lb</b>
Capacity:						
Struck (SAE)	17.6 m <sup>3</sup>	<b>23.0 yd<sup>3</sup></b>	17.5 m <sup>3</sup>	<b>22.9 yd<sup>3</sup></b>	17.6 m <sup>3</sup>	<b>23.0 yd<sup>3</sup></b>
Heaped (2:1) (SAE)	25.2 m <sup>3</sup>	<b>33.0 yd<sup>3</sup></b>	24.9 m <sup>3</sup>	<b>32.5 yd<sup>3</sup></b>	25.2 m <sup>3</sup>	<b>32.9 yd<sup>3</sup></b>
Distribution Empty:						
Front		<b>51%</b>		<b>51%</b>		<b>51%</b>
Rear		<b>49%</b>		<b>49%</b>		<b>49%</b>
Distribution Loaded:						
Front		<b>34%</b>		<b>34%</b>		<b>34%</b>
Rear		<b>66%</b>		<b>66%</b>		<b>66%</b>
Engine Model	<b>C15 ACERT</b>		<b>C15 ACERT</b>		<b>C15 ACERT</b>	
Number of Cylinders	<b>6</b>		<b>6</b>		<b>6</b>	
Bore	137 mm	<b>5.4"</b>	137 mm	<b>5.4"</b>	137 mm	<b>5.4"</b>
Stroke	171 mm	<b>6.7"</b>	171 mm	<b>6.7"</b>	171 mm	<b>6.7"</b>
Displacement	15 L	<b>928 in<sup>3</sup></b>	15 L	<b>928 in<sup>3</sup></b>	15 L	<b>928 in<sup>3</sup></b>
Net Power	360 kW	<b>483 hp</b>	360 kW	<b>483 hp</b>	360 kW	<b>483 hp</b>
Gross Power	381 kW	<b>511 hp</b>	381 kW	<b>511 hp</b>	381 kW	<b>511 hp</b>
Standard Tires	<b>18.00R33 (E4)</b>		<b>18.00R33 (E4)</b>		<b>18.00R33 (E4)</b>	
Machine Clearance Turning Circle	20.30 m	<b>66'6"</b>	20.30 m	<b>66'6"</b>	20.30 m	<b>66'6"</b>
Fuel Tank Refill Capacity	529 L	<b>140 U.S. gal</b>	529 L	<b>140 U.S. gal</b>	529 L	<b>140 U.S. gal</b>
Top Speed (Loaded)	73.5 km/h	<b>45.7 mph</b>	73.5 km/h	<b>45.7 mph</b>	73.5 km/h	<b>45.7 mph</b>
<b>GENERAL DIMENSIONS (Empty):</b>						
Height to Canopy Rock Guard Rail	4.21 m	<b>13'10"</b>	4.21 m	<b>13'10"</b>	4.21 m	<b>13'10"</b>
Wheelbase	3.96 m	<b>13'0"</b>	3.96 m	<b>13'0"</b>	3.96 m	<b>13'0"</b>
Overall Length (Operating)	8.80 m	<b>28'10"</b>	8.80 m	<b>28'10"</b>	8.80 m	<b>28'10"</b>
Overall Length (Shipping)	8.80 m	<b>28'10"</b>	8.80 m	<b>28'10"</b>	8.80 m	<b>28'10"</b>
Loading Height (Empty)	3.23 m	<b>10'7"</b>	3.23 m	<b>10'7"</b>	3.23 m	<b>10'7"</b>
Height at Full Dump	8.28 m	<b>27'2"</b>	8.28 m	<b>27'2"</b>	8.28 m	<b>27'2"</b>
Body Length (Target Length)	5.64 m	<b>18'6"</b>	5.64 m	<b>18'6"</b>	5.65 m	<b>18'6"</b>
Width (Operating)	4.78 m	<b>15'8"</b>	4.78 m	<b>15'8"</b>	4.78 m	<b>15'8"</b>
Width (Shipping)***	3.95 m	<b>13'0"</b>	3.95 m	<b>13'0"</b>	3.95 m	<b>13'0"</b>
Front Tire Tread	3.11 m	<b>10'3"</b>	3.11 m	<b>10'3"</b>	3.11 m	<b>10'3"</b>

\*Weights include lubricants, coolants and 100% fuel.

\*\*Refer to Caterpillar's 10/10/20 Payload Policy for Off-Highway Trucks.

\*\*\*Disassembled.

\*\*\*\*Meets Tier 3, Stage IIIA, Japan 2006 (Tier 3) equivalent emission standards and Tier 2, Stage II, Japan 2001 (Tier 2) equivalent emission standards.

MODEL	772G		772G		772G	
Body Type	Flat Floor		Quarry Body		Dual Slope	
Emission Standards	Tier 4 Final****		Tier 4 Final****		Tier 4 Final****	
Gross Machine Weight	82 100 kg	<b>181,000 lb</b>	82 100 kg	<b>181,000 lb</b>	82 100 kg	<b>181,000 lb</b>
Chassis Weight*	26 356 kg	<b>58,105 lb</b>	26 356 kg	<b>58,105 lb</b>	26 356 kg	<b>58,105 lb</b>
Body Weight	8340 kg	<b>18,387 lb</b>	10 555 kg	<b>23,270 lb</b>	8147 kg	<b>17,961 lb</b>
Payload Without Liner	47 404 kg	<b>104,508 lb</b>	45 189 kg	<b>99,625 lb</b>	47 597 kg	<b>104,933 lb</b>
Standard Liner Weight	3235 kg	<b>7132 lb</b>	—		3093 kg	<b>6819 lb</b>
Target Payload**	44 169 kg	<b>97,376 lb</b>	—		44 504 kg	<b>98,114 lb</b>
Capacity:						
Struck (SAE)	23.4 m <sup>3</sup>	<b>30.6 yd<sup>3</sup></b>	23.4 m <sup>3</sup>	<b>30.6 yd<sup>3</sup></b>	24.1 m <sup>3</sup>	<b>31.5 yd<sup>3</sup></b>
Heaped (2:1) (SAE)	31.3 m <sup>3</sup>	<b>40.9 yd<sup>3</sup></b>	31.3 m <sup>3</sup>	<b>40.9 yd<sup>3</sup></b>	32 m <sup>3</sup>	<b>41.9 yd<sup>3</sup></b>
Distribution Empty:						
Front		<b>51%</b>		<b>51%</b>		<b>51%</b>
Rear		<b>49%</b>		<b>49%</b>		<b>49%</b>
Distribution Loaded:						
Front		<b>34%</b>		<b>34%</b>		<b>34%</b>
Rear		<b>66%</b>		<b>66%</b>		<b>66%</b>
Engine Model	<b>C18 ACERT</b>		<b>C18 ACERT</b>		<b>C18 ACERT</b>	
Number of Cylinders	<b>6</b>		<b>6</b>		<b>6</b>	
Bore	145 mm	<b>5.7"</b>	145 mm	<b>5.7"</b>	145 mm	<b>5.7"</b>
Stroke	183 mm	<b>7.2"</b>	183 mm	<b>7.2"</b>	183 mm	<b>7.2"</b>
Displacement	18 L	<b>1105 in<sup>3</sup></b>	18 L	<b>1105 in<sup>3</sup></b>	18 L	<b>1105 in<sup>3</sup></b>
Net Power	410 kW	<b>550 hp</b>	410 kW	<b>550 hp</b>	410 kW	<b>550 hp</b>
Gross Power	451 kW	<b>605 hp</b>	451 kW	<b>605 hp</b>	451 kW	<b>605 hp</b>
Standard Tires	<b>21.00R33 (E4)</b>		<b>21.00R33 (E4)</b>		<b>21.00R33 (E4)</b>	
Machine Clearance Turning Circle	21.6 m	<b>70'10"</b>	21.6 m	<b>70'10"</b>	21.6 m	<b>70'10"</b>
Fuel Tank Refill Capacity	529 L	<b>140 U.S. gal</b>	529 L	<b>140 U.S. gal</b>	529 L	<b>140 U.S. gal</b>
Diesel Exhaust Fluid Refill Capacity	21 L	<b>6 U.S. gal</b>	21 L	<b>6 U.S. gal</b>	21 L	<b>6 U.S. gal</b>
Top Speed (Loaded)	79.7 km/h	<b>49.5 mph</b>	79.7 km/h	<b>49.5 mph</b>	79.7 km/h	<b>49.5 mph</b>
<b>GENERAL DIMENSIONS (Empty):</b>						
Height to Canopy Rock Guard Rail	4.21 m	<b>13'10"</b>	4.21 m	<b>13'10"</b>	4.21 m	<b>13'10"</b>
Wheelbase	3.96 m	<b>13'0"</b>	3.96 m	<b>13'0"</b>	3.96 m	<b>13'0"</b>
Overall Length (Operating)	8.80 m	<b>28'10"</b>	8.80 m	<b>28'10"</b>	8.80 m	<b>28'10"</b>
Overall Length (Shipping)	8.80 m	<b>28'10"</b>	8.80 m	<b>28'10"</b>	8.80 m	<b>28'10"</b>
Loading Height (Empty)	3.64 m	<b>11'11"</b>	3.64 m	<b>11'11"</b>	3.64 m	<b>11'11"</b>
Height at Full Dump	8.28 m	<b>27'2"</b>	8.28 m	<b>27'2"</b>	8.28 m	<b>27'2"</b>
Body Length (Target Length)	5.78 m	<b>19'0"</b>	5.78 m	<b>19'0"</b>	5.79 m	<b>19'0"</b>
Width (Operating)	4.78 m	<b>15'8"</b>	4.78 m	<b>15'8"</b>	4.78 m	<b>15'8"</b>
Width (Shipping)***	3.95 m	<b>13'0"</b>	3.95 m	<b>13'0"</b>	3.95 m	<b>13'0"</b>
Front Tire Tread	3.11 m	<b>10'3"</b>	3.11 m	<b>10'3"</b>	3.11 m	<b>10'3"</b>

\*Weights include lubricants, coolants and 100% fuel.

\*\*Refer to Caterpillar's 10/10/20 Payload Policy for Off-Highway Trucks.

\*\*\*Disassembled.

\*\*\*\*Meets Tier 4 Final, Stage IV, and Japan 2014 (Tier 4 Final) emission standards.

MODEL	772G		772G		772G	
Body Type	Flat Floor		Quarry Body		Dual Slope	
Emission Standards	Tier 3 Equivalent and Tier 2 Equivalent****		Tier 3 Equivalent and Tier 2 Equivalent****		Tier 3 Equivalent and Tier 2 Equivalent****	
Gross Machine Weight	82 100 kg	<b>181,000 lb</b>	82 100 kg	<b>181,000 lb</b>	82 100 kg	<b>181,000 lb</b>
Chassis Weight*	26 863 kg	<b>59,222 lb</b>	26 863 kg	<b>59,222 lb</b>	26 863 kg	<b>59,222 lb</b>
Body Weight	8215 kg	<b>18,111 lb</b>	10 555 kg	<b>23,270 lb</b>	8030 kg	<b>17,703 lb</b>
Payload Without Liner	47 022 kg	<b>103,667 lb</b>	44 682 kg	<b>98,508 lb</b>	47 207 kg	<b>104,075 lb</b>
Standard Liner Weight	3235 kg	<b>7132 lb</b>	—		2995 kg	<b>6603 lb</b>
Target Payload**	43 787 kg	<b>96,535 lb</b>	—		44 212 kg	<b>97,472 lb</b>
Capacity:						
Struck (SAE)	24.0 m <sup>3</sup>	<b>31.4 yd<sup>3</sup></b>	23.7 m <sup>3</sup>	<b>31.1 yd<sup>3</sup></b>	23.9 m <sup>3</sup>	<b>31.3 yd<sup>3</sup></b>
Heaped (2:1) (SAE)	31.3 m <sup>3</sup>	<b>41.0 yd<sup>3</sup></b>	31.1 m <sup>3</sup>	<b>40.6 yd<sup>3</sup></b>	31.2 m <sup>3</sup>	<b>40.8 yd<sup>3</sup></b>
Distribution Empty:						
Front		<b>51%</b>		<b>51%</b>		<b>51%</b>
Rear		<b>49%</b>		<b>49%</b>		<b>49%</b>
Distribution Loaded:						
Front		<b>34%</b>		<b>34%</b>		<b>34%</b>
Rear		<b>66%</b>		<b>66%</b>		<b>66%</b>
Engine Model	<b>C18 ACERT</b>		<b>C18 ACERT</b>		<b>C18 ACERT</b>	
Number of Cylinders	<b>6</b>		<b>6</b>		<b>6</b>	
Bore	145 mm	<b>5.7"</b>	145 mm	<b>5.7"</b>	145 mm	<b>5.7"</b>
Stroke	183 mm	<b>7.2"</b>	183 mm	<b>7.2"</b>	183 mm	<b>7.2"</b>
Displacement	18 L	<b>1105 in<sup>3</sup></b>	18 L	<b>1105 in<sup>3</sup></b>	18 L	<b>1105 in<sup>3</sup></b>
Net Power	415 kW	<b>556 hp</b>	415 kW	<b>556 hp</b>	415 kW	<b>556 hp</b>
Gross Power	446 kW	<b>598 hp</b>	446 kW	<b>598 hp</b>	446 kW	<b>598 hp</b>
Standard Tires	<b>21.00R33 (E4)</b>		<b>21.00R33 (E4)</b>		<b>21.00R33 (E4)</b>	
Machine Clearance Turning Circle	21.6 m	<b>70'10"</b>	21.6 m	<b>70'10"</b>	21.6 m	<b>70'10"</b>
Fuel Tank Refill Capacity	529 L	<b>140 U.S. gal</b>	529 L	<b>140 U.S. gal</b>	529 L	<b>140 U.S. gal</b>
Top Speed (Loaded)	79.7 km/h	<b>49.5 mph</b>	79.7 km/h	<b>49.5 mph</b>	79.7 km/h	<b>49.5 mph</b>
<b>GENERAL DIMENSIONS (Empty):</b>						
Height to Canopy Rock Guard Rail	4.21 m	<b>13'10"</b>	4.21 m	<b>13'10"</b>	4.21 m	<b>13'10"</b>
Wheelbase	3.96 m	<b>13'0"</b>	3.96 m	<b>13'0"</b>	3.96 m	<b>13'0"</b>
Overall Length (Operating)	8.80 m	<b>28'10"</b>	8.80 m	<b>28'10"</b>	8.80 m	<b>28'10"</b>
Overall Length (Shipping)	8.80 m	<b>28'10"</b>	8.80 m	<b>28'10"</b>	8.80 m	<b>28'10"</b>
Loading Height (Empty)	3.64 m	<b>11'11"</b>	3.64 m	<b>11'11"</b>	3.64 m	<b>11'11"</b>
Height at Full Dump	8.28 m	<b>27'2"</b>	8.28 m	<b>27'2"</b>	8.28 m	<b>27'2"</b>
Body Length (Target Length)	5.78 m	<b>19'0"</b>	5.78 m	<b>19'0"</b>	5.79 m	<b>19'0"</b>
Width (Operating)	4.78 m	<b>15'8"</b>	4.78 m	<b>15'8"</b>	4.78 m	<b>15'8"</b>
Width (Shipping)***	3.95 m	<b>13'0"</b>	3.95 m	<b>13'0"</b>	3.95 m	<b>13'0"</b>
Front Tire Tread	3.11 m	<b>10'3"</b>	3.11 m	<b>10'3"</b>	3.11 m	<b>10'3"</b>

\*Weights include lubricants, coolants and 100% fuel.

\*\*Refer to Caterpillar's 10/10/20 Payload Policy for Off-Highway Trucks.

\*\*\*Disassembled.

\*\*\*\*Meets Tier 3, Stage IIIA, Japan 2006 (Tier 3) equivalent emission standards and Tier 2, Stage II, Japan 2001 (Tier 2) equivalent emission standards.



<b>MODEL</b>	<b>773E****</b>		<b>773G*****</b>	
Body Type	<b>Medium Impact Steel Dual Slope</b>		<b>Flat Floor Steel Lined</b>	
Emission Standards	<b>Tier 2 equivalent</b>		<b>Tier 4 Final</b>	
Gross Machine Weight	99 300 kg	<b>218,919 lb</b>	102 739 kg	<b>226,500 lb</b>
Chassis Weight*	30 794 kg	<b>67,889 lb</b>	35 191 kg	<b>77,582 lb</b>
Body Weight	9400 kg	<b>20,723 lb</b>	11 423 kg	<b>25,184 lb</b>
Payload Without Liner	59 106 kg	<b>130,306 lb</b>	56 125 kg	<b>123,735 lb</b>
Standard Liner Weight	4038 kg	<b>8,902 lb</b>	3794 kg	<b>8363 lb</b>
Target Payload**	55 068 kg	<b>121,404 lb</b>	52 332 kg	<b>115,372 lb</b>
Capacity:				
Struck (SAE)	26.6 m <sup>3</sup>	<b>34.8 yd<sup>3</sup></b>	25.8 m <sup>3</sup>	<b>33.7 yd<sup>3</sup></b>
Heaped (2:1) (SAE)	35.2 m <sup>3</sup>	<b>46 yd<sup>3</sup></b>	35.0 m <sup>3</sup>	<b>45.8 yd<sup>3</sup></b>
Distribution Empty:				
Front		<b>46.6%</b>		<b>50%</b>
Rear		<b>53.4%</b>		<b>50%</b>
Distribution Loaded:				
Front		<b>33.8%</b>		<b>35%</b>
Rear		<b>66.2%</b>		<b>65%</b>
Engine Model	<b>3412E</b>		<b>C27 ACERT</b>	
Number of Cylinders	<b>12</b>		<b>12</b>	
Bore	137 mm	<b>5.4"</b>	137 mm	<b>5.4"</b>
Stroke	152 mm	<b>6"</b>	152 mm	<b>6"</b>
Displacement	27 L	<b>1649 in<sup>3</sup></b>	27 L	<b>1649 in<sup>3</sup></b>
Net Power	537 kW	<b>720 hp</b>	534 kW	<b>717 hp</b>
Gross Power	567 kW	<b>760 hp</b>	578 kW	<b>775 hp</b>
Standard Tires	<b>24.00R35 (E4)</b>		<b>24.00R35 (E4)</b>	
Machine Clearance Turning Circle	25 m	<b>82'0"</b>	26.5 m	<b>86'11"</b>
Fuel Tank Refill Capacity	700 L	<b>185 U.S. gal</b>	795 L	<b>210 U.S. gal</b>
Top Speed (Loaded)	67.6 km/h	<b>42.0 mph</b>	66.9 km/h	<b>41.6 mph</b>
<b>GENERAL DIMENSIONS (Empty):</b>				
Height to Canopy Rock Guard Rail	4.39 m	<b>14'5"</b>	4.46 m	<b>14'7"</b>
Wheelbase	4.19 m	<b>13'9"</b>	4.22 m	<b>13'10"</b>
Overall Length (Operating)	9.6 m	<b>31'6"</b>	10.15 m	<b>33'4"</b>
Overall Length (Shipping)	9.12 m	<b>29'11"</b>	9.2 m	<b>30'2"</b>
Loading Height (Empty)	3.77 m	<b>12'4"</b>	3.77 m	<b>12'5"</b>
Height at Full Dump	8.79 m	<b>28'10"</b>	9.28 m	<b>30'5"</b>
Body Length (Target Length)	6.40 m	<b>21'0"</b>	6.1 m	<b>20'0"</b>
Width (Operating)	5.07 m	<b>16'8"</b>	5.67 m	<b>18'7"</b>
Width (Shipping)***	3.99 m	<b>13'11"</b>	3.99 m	<b>13'11"</b>
Front Tire Tread	3.28 m	<b>10'9"</b>	3.21 m	<b>10'6"</b>

\*Weights include lubricants, coolants and 100% fuel.

\*\*Refer to Caterpillar's 10/10/20 Payload Policy for Off-Highway Trucks.

\*\*\*Disassembled.

\*\*\*\*India sourced, not available in all regions.

\*\*\*\*\*Gateless Coal Bodies are available through OEM Solutions.

MODEL	773G****		773G****		773G****	
Body Type	Dual Slope Steel Lined		Flat Floor Steel Lined		Dual Slope Steel Lined	
Emission Standards	Tier 4 Final		Tier 2 equivalent		Tier 2 equivalent	
Gross Machine Weight	102 739 kg	<b>226,500 lb</b>	102 739 kg	<b>226,500 lb</b>	102 739 kg	<b>226,500 lb</b>
Chassis Weight*	35 191 kg	<b>77,582 lb</b>	34 536 kg	<b>76,139 lb</b>	34 536 kg	<b>76,139 lb</b>
Body Weight	11 049 kg	<b>24,358 lb</b>	11 423 kg	<b>25,184 lb</b>	11 049 kg	<b>24,358 lb</b>
Payload Without Liner	56 500 kg	<b>124,560 lb</b>	56 780 kg	<b>125,178 lb</b>	57 154 kg	<b>126,003 lb</b>
Standard Liner Weight	3728 kg	<b>8218 lb</b>	3794 kg	<b>8363 lb</b>	3728 kg	<b>8218 lb</b>
Target Payload**	52 772 kg	<b>116,342 lb</b>	52 986 kg	<b>116,815 lb</b>	53 426 kg	<b>117,785 lb</b>
Capacity:						
Struck (SAE)	26.4 m <sup>3</sup>	<b>34.5 yd<sup>3</sup></b>	25.8 m <sup>3</sup>	<b>33.7 yd<sup>3</sup></b>	26.4 m <sup>3</sup>	<b>34.5 yd<sup>3</sup></b>
Heaped (2:1) (SAE)	35.2 m <sup>3</sup>	<b>46.0 yd<sup>3</sup></b>	35.0 m <sup>3</sup>	<b>45.8 yd<sup>3</sup></b>	35.2 m <sup>3</sup>	<b>46.0 yd<sup>3</sup></b>
Distribution Empty:						
Front		<b>50%</b>		<b>49%</b>		<b>50%</b>
Rear		<b>50%</b>		<b>51%</b>		<b>50%</b>
Distribution Loaded:						
Front		<b>35%</b>		<b>34%</b>		<b>35%</b>
Rear		<b>65%</b>		<b>66%</b>		<b>65%</b>
Engine Model	<b>C27 ACERT</b>		<b>C27 ACERT</b>		<b>C27 ACERT</b>	
Number of Cylinders	<b>12</b>		<b>12</b>		<b>12</b>	
Bore	137 mm	<b>5.4"</b>	137 mm	<b>5.4"</b>	137 mm	<b>5.4"</b>
Stroke	152 mm	<b>6"</b>	152 mm	<b>6"</b>	152 mm	<b>6"</b>
Displacement	27 L	<b>1649 in<sup>3</sup></b>	27 L	<b>1649 in<sup>3</sup></b>	27 L	<b>1649 in<sup>3</sup></b>
Net Power	534 kW	<b>717 hp</b>	546 kW	<b>733 hp</b>	546 kW	<b>733 hp</b>
Gross Power	578 kW	<b>775 hp</b>	578 kW	<b>775 hp</b>	578 kW	<b>775 hp</b>
Standard Tires	<b>24.00R35 (E4)</b>		<b>24.00R35 (E4)</b>		<b>24.00R35 (E4)</b>	
Machine Clearance Turning Circle	26.5 m	<b>86'11"</b>	26.5 m	<b>86'11"</b>	26.5 m	<b>86'11"</b>
Fuel Tank Refill Capacity	795 L	<b>210 U.S. gal</b>	795 L	<b>210 U.S. gal</b>	795 L	<b>210 U.S. gal</b>
Top Speed (Loaded)	66.9 km/h	<b>41.6 mph</b>	67.6 km/h	<b>42.0 mph</b>	67.6 km/h	<b>42.0 mph</b>
<b>GENERAL DIMENSIONS (Empty):</b>						
Height to Canopy Rock Guard Rail	4.46 m	<b>14'7"</b>	4.46 m	<b>14'7"</b>	4.46 m	<b>14'7"</b>
Wheelbase	4.22 m	<b>13'10"</b>	4.22 m	<b>13'10"</b>	4.22 m	<b>13'10"</b>
Overall Length (Operating)	10.07 m	<b>33'1"</b>	10.15 m	<b>33'4"</b>	10.07 m	<b>33'1"</b>
Overall Length (Shipping)	9.2 m	<b>30'2"</b>	9.2 m	<b>30'2"</b>	9.2 m	<b>30'2"</b>
Loading Height (Empty)	3.77 m	<b>12'5"</b>	3.77 m	<b>12'5"</b>	3.77 m	<b>12'5"</b>
Height at Full Dump	9.28 m	<b>30'5"</b>	9.28 m	<b>30'5"</b>	9.28 m	<b>30'5"</b>
Body Length (Target Length)	6.1 m	<b>20'0"</b>	6.1 m	<b>20'0"</b>	6.1 m	<b>20'0"</b>
Width (Operating)	5.67 m	<b>18'7"</b>	5.67 m	<b>18'7"</b>	5.67 m	<b>18'7"</b>
Width (Shipping)***	3.99 m	<b>13'11"</b>	3.99 m	<b>13'11"</b>	3.99 m	<b>13'11"</b>
Front Tire Tread	3.21 m	<b>10'6"</b>	3.21 m	<b>10'6"</b>	3.21 m	<b>10'6"</b>

\*Weights include lubricants, coolants and 100% fuel.

\*\*Refer to Caterpillar's 10/10/20 Payload Policy for Off-Highway Trucks.

\*\*\*Disassembled.

\*\*\*\*Gateless Coal Bodies are available through OEM Solutions.

# Mining & Off-Highway Trucks | Specifications

MODEL	775G****		775G****		775G****	
Body Type	Flat Floor Steel Lined		Quarry Body		Dual Slope Steel Lined	
Emission Standards	Tier 4 Final		Tier 4 Final		Tier 4 Final	
Gross Machine Weight	111 811 kg	<b>246,500 lb</b>	111 811 kg	<b>246,500 lb</b>	111 811 kg	<b>246,500 lb</b>
Chassis Weight*	35 281 kg	<b>77,781 lb</b>	35 281 kg	<b>77,781 lb</b>	35 281 kg	<b>77,781 lb</b>
Body Weight	11 760 kg	<b>25,925 lb</b>	13 827 kg	<b>30,483 lb</b>	11 466 kg	<b>25,277 lb</b>
Payload Without Liner	64 770 kg	<b>142,794 lb</b>	62 703 kg	<b>138,236 lb</b>	65 064 kg	<b>143,442 lb</b>
Standard Liner Weight	4124 kg	<b>9094 lb</b>	—	—	4015 kg	<b>8854 lb</b>
Target Payload**	60 646 kg	<b>133,700 lb</b>	—	—	61 048 kg	<b>134,588 lb</b>
Capacity:						
Struck (SAE)	31.7 m <sup>3</sup>	<b>41.5 yd<sup>3</sup></b>	32.0 m <sup>3</sup>	<b>41.9 yd<sup>3</sup></b>	32.1 m <sup>3</sup>	<b>42.0 yd<sup>3</sup></b>
Heaped (2:1) (SAE)	41.6 m <sup>3</sup>	<b>54.4 yd<sup>3</sup></b>	41.9 m <sup>3</sup>	<b>54.8 yd<sup>3</sup></b>	41.7 m <sup>3</sup>	<b>54.5 yd<sup>3</sup></b>
Distribution Empty:						
Front		<b>49%</b>		<b>51%</b>		<b>49%</b>
Rear		<b>51%</b>		<b>49%</b>		<b>51%</b>
Distribution Loaded:						
Front		<b>34%</b>		<b>34%</b>		<b>34%</b>
Rear		<b>66%</b>		<b>66%</b>		<b>66%</b>
Engine Model	<b>C27 ACERT</b>		<b>C27 ACERT</b>		<b>C27 ACERT</b>	
Number of Cylinders	<b>12</b>		<b>12</b>		<b>12</b>	
Bore	137 mm	<b>5.4"</b>	137 mm	<b>5.4"</b>	137 mm	<b>5.4"</b>
Stroke	152 mm	<b>6"</b>	152 mm	<b>6"</b>	152 mm	<b>6"</b>
Displacement	27 L	<b>1649 in<sup>3</sup></b>	27 L	<b>1649 in<sup>3</sup></b>	27 L	<b>1649 in<sup>3</sup></b>
Net Power	572 kW	<b>767 hp</b>	572 kW	<b>767 hp</b>	572 kW	<b>767 hp</b>
Gross Power	615 kW	<b>825 hp</b>	615 kW	<b>825 hp</b>	615 kW	<b>825 hp</b>
Standard Tires	<b>24.00R35 (E4)</b>		<b>24.00R35 (E4)</b>		<b>24.00R35 (E4)</b>	
Machine Clearance Turning Circle	26.5 m	<b>86'11"</b>	26.5 m	<b>86'11"</b>	26.5 m	<b>86'11"</b>
Fuel Tank Refill Capacity	795 L	<b>210 U.S. gal</b>	795 L	<b>210 U.S. gal</b>	795 L	<b>210 U.S. gal</b>
Top Speed (Loaded)	66.9 km/h	<b>41.6 mph</b>	66.9 km/h	<b>41.6 mph</b>	66.9 km/h	<b>41.6 mph</b>
<b>GENERAL DIMENSIONS (Empty):</b>						
Height to Canopy Rock Guard Rail	4.46 m	<b>14'7"</b>	4.46 m	<b>14'7"</b>	4.46 m	<b>14'7"</b>
Wheelbase	4.22 m	<b>13'10"</b>	4.22 m	<b>13'10"</b>	4.22 m	<b>13'10"</b>
Overall Length (Operating)	10.15 m	<b>33'4"</b>	10.15 m	<b>33'4"</b>	10.07 m	<b>33'1"</b>
Overall Length (Shipping)	9.21 m	<b>30'3"</b>	9.21 m	<b>30'3"</b>	9.21 m	<b>30'3"</b>
Loading Height (Empty)	3.97 m	<b>13'0"</b>	3.97 m	<b>13'0"</b>	3.97 m	<b>13'0"</b>
Height at Full Dump	9.28 m	<b>30'5"</b>	9.28 m	<b>30'5"</b>	9.28 m	<b>30'5"</b>
Body Length (Target Length)	6.1 m	<b>20'0"</b>	6.1 m	<b>20'0"</b>	6.1 m	<b>20'0"</b>
Width (Operating)	5.67 m	<b>18'7"</b>	5.67 m	<b>18'7"</b>	5.67 m	<b>18'7"</b>
Width (Shipping)***	3.97 m	<b>13'0"</b>	3.97 m	<b>13'0"</b>	3.97 m	<b>13'0"</b>
Front Tire Tread	3.21 m	<b>10'6"</b>	3.21 m	<b>10'6"</b>	3.21 m	<b>10'6"</b>

\*Weights include lubricants, coolants and 100% fuel.

\*\*Refer to Caterpillar's 10/10/20 Payload Policy for Off-Highway Trucks.

\*\*\*Disassembled.

\*\*\*\*Gateless Coal Bodies are available through OEM Solutions.

MODEL	775G****		775G****		775G****	
Body Type	Flat Floor Steel Lined		Quarry Body		Dual Slope Steel Lined	
Emission Standards	Tier 2 equivalent		Tier 2 equivalent		Tier 2 equivalent	
Gross Machine Weight	111 811 kg	<b>246,500 lb</b>	111 811 kg	<b>246,500 lb</b>	111 811 kg	<b>246,500 lb</b>
Chassis Weight*	34 622 kg	<b>76,327 lb</b>	34 622 kg	<b>76,327 lb</b>	34 622 kg	<b>76,327 lb</b>
Body Weight	11 760 kg	<b>25,925 lb</b>	13 827 kg	<b>30,483 lb</b>	11 466 kg	<b>25,277 lb</b>
Payload Without Liner	65 430 kg	<b>144,248 lb</b>	63 362 kg	<b>139,690 lb</b>	65 724 kg	<b>144,896 lb</b>
Standard Liner Weight	4124 kg	<b>9094 lb</b>	—		4015 kg	<b>8854 lb</b>
Target Payload**	61 305 kg	<b>135,154 lb</b>	—		61,708 kg	<b>136,042 lb</b>
Capacity:						
Struck (SAE)	31.7 m <sup>3</sup>	<b>41.5 yd<sup>3</sup></b>	32.0 m <sup>3</sup>	<b>41.9 yd<sup>3</sup></b>	32.1 m <sup>3</sup>	<b>42.0 yd<sup>3</sup></b>
Heaped (2:1) (SAE)	41.6 m <sup>3</sup>	<b>54.4 yd<sup>3</sup></b>	41.9 m <sup>3</sup>	<b>54.8 yd<sup>3</sup></b>	41.7 m <sup>3</sup>	<b>54.5 yd<sup>3</sup></b>
Distribution Empty:						
Front		<b>49%</b>		<b>51%</b>		<b>49%</b>
Rear		<b>51%</b>		<b>49%</b>		<b>51%</b>
Distribution Loaded:						
Front		<b>34%</b>		<b>34%</b>		<b>34%</b>
Rear		<b>66%</b>		<b>66%</b>		<b>66%</b>
Engine Model	<b>C27 ACERT</b>		<b>C27 ACERT</b>		<b>C27 ACERT</b>	
Number of Cylinders	<b>12</b>		<b>12</b>		<b>12</b>	
Bore	137 mm	<b>5.4"</b>	137 mm	<b>5.4"</b>	137 mm	<b>5.4"</b>
Stroke	152 mm	<b>6"</b>	152 mm	<b>6"</b>	152 mm	<b>6"</b>
Displacement	27 L	<b>1649 in<sup>3</sup></b>	27 L	<b>1649 in<sup>3</sup></b>	27 L	<b>1649 in<sup>3</sup></b>
Net Power	584 kW	<b>783 hp</b>	584 kW	<b>783 hp</b>	584 kW	<b>783 hp</b>
Gross Power	615 kW	<b>825 hp</b>	615 kW	<b>825 hp</b>	615 kW	<b>825 hp</b>
Standard Tires	<b>24.00R35 (E4)</b>		<b>24.00R35 (E4)</b>		<b>24.00R35 (E4)</b>	
Machine Clearance Turning Circle	26.5 m	<b>86'11"</b>	26.5 m	<b>86'11"</b>	26.5 m	<b>86'11"</b>
Fuel Tank Refill Capacity	795 L	<b>210 U.S. gal</b>	795 L	<b>210 U.S. gal</b>	795 L	<b>210 U.S. gal</b>
Top Speed (Loaded)	67.6 km/h	<b>42.0 mph</b>	67.6 km/h	<b>42.0 mph</b>	67.6 km/h	<b>42.0 mph</b>
<b>GENERAL DIMENSIONS (Empty):</b>						
Height to Canopy Rock Guard Rail	4.46 m	<b>14'7"</b>	4.46 m	<b>14'7"</b>	4.46 m	<b>14'7"</b>
Wheelbase	4.22 m	<b>13'10"</b>	4.22 m	<b>13'10"</b>	4.22 m	<b>13'10"</b>
Overall Length (Operating)	10.15 m	<b>33'4"</b>	10.15 m	<b>33'4"</b>	10.07 m	<b>33'1"</b>
Overall Length (Shipping)	9.21 m	<b>30'3"</b>	9.21 m	<b>30'3"</b>	9.21 m	<b>30'3"</b>
Loading Height (Empty)	3.97 m	<b>13'0"</b>	3.97 m	<b>13'0"</b>	3.97 m	<b>13'0"</b>
Height at Full Dump	9.28 m	<b>30'5"</b>	9.28 m	<b>30'5"</b>	9.28 m	<b>30'5"</b>
Body Length (Target Length)	6.1 m	<b>20'0"</b>	6.1 m	<b>20'0"</b>	6.1 m	<b>20'0"</b>
Width (Operating)	5.67 m	<b>18'7"</b>	5.67 m	<b>18'7"</b>	5.67 m	<b>18'7"</b>
Width (Shipping)***	3.97 m	<b>13'0"</b>	3.97 m	<b>13'0"</b>	3.97 m	<b>13'0"</b>
Front Tire Tread	3.21 m	<b>10'6"</b>	3.21 m	<b>10'6"</b>	3.21 m	<b>10'6"</b>

\*Weights include lubricants, coolants and 100% fuel.

\*\*Refer to Caterpillar's 10/10/20 Payload Policy for Off-Highway Trucks.

\*\*\*Disassembled.

\*\*\*\*Gateless Coal Bodies are available through OEM Solutions.

# Mining & Off-Highway Trucks | Specifications

MODEL	777E****		777G*****		777G*****	
Body Type	Medium Impact Steel Dual Slope		Dual Slope		X-Body	
Emission Standards	Tier 2 equivalent		Tier 4 Final		Tier 4 Final	
Gross Machine Weight	163 360 kg	<b>360,147 lb</b>	164 654 kg	<b>363,000 lb</b>	164 654 kg	<b>363,000 lb</b>
Chassis Weight*	49 088 kg	<b>108,220 lb</b>	52 241 kg	<b>115,171 lb</b>	52 241 kg	<b>115,171 lb</b>
Body Weight	16 070 kg	<b>35,428 lb</b>	16 075 kg	<b>35,429 lb</b>	15 878 kg	<b>35,005 lb</b>
Payload without Liner	98 202 kg	<b>216,496 lb</b>	96 338 kg	<b>212,389 lb</b>	96 535 kg	<b>212,823 lb</b>
Standard Liner Weight	5595 kg	<b>12,335 lb</b>	5695 kg	<b>12,555 lb</b>	4686 kg	<b>10,331 lb</b>
Target Payload**	92 607 kg	<b>204,163 lb</b>	90 643 kg	<b>199,833</b>	91 849 kg	<b>202,492 lb</b>
Capacity:						
Struck (SAE)	42 m <sup>3</sup>	<b>54.6 yd<sup>3</sup></b>	42 m <sup>3</sup>	<b>54.6 yd<sup>3</sup></b>	42 m <sup>3</sup>	<b>54.6 yd<sup>3</sup></b>
Heaped (2:1) (SAE)	60.2 m <sup>3</sup>	<b>78.6 yd<sup>3</sup></b>	60.2 m <sup>3</sup>	<b>78.6 yd<sup>3</sup></b>	60.2 m <sup>3</sup>	<b>78.6 yd<sup>3</sup></b>
Distribution Empty:						
Front		<b>45.9%</b>		<b>41.8%</b>		<b>41.8%</b>
Rear		<b>54.1%</b>		<b>58.2%</b>		<b>58.2%</b>
Distribution Loaded:						
Front		<b>30.4%</b>		<b>33%</b>		<b>33%</b>
Rear		<b>69.6%</b>		<b>67%</b>		<b>67%</b>
Engine Model	<b>C32 ACERT</b>		<b>C32 ACERT</b>		<b>C32 ACERT</b>	
Number of Cylinders	<b>12</b>		<b>12</b>		<b>12</b>	
Bore	145 mm	<b>5.7"</b>	145 mm	<b>5.7"</b>	145 mm	<b>5.7"</b>
Stroke	162 mm	<b>6.4"</b>	162 mm	<b>6.4"</b>	162 mm	<b>6.4"</b>
Displacement	32.1 L	<b>1959 in<sup>3</sup></b>	32.1 L	<b>1959 in<sup>3</sup></b>	32.1 L	<b>1959 in<sup>3</sup></b>
Net Power	708 kW	<b>949 hp</b>	683 kW	<b>916 hp</b>	683 kW	<b>916 hp</b>
Gross Power	758 kW	<b>1016 hp</b>	765 kW	<b>1025 hp</b>	765 kW	<b>1025 hp</b>
Standard Tires	<b>27.00R49 (E4)</b>		<b>27.00R49</b>		<b>27.00R49</b>	
Machine Clearance Turning Circle	28.4 m	<b>83'0"</b>	28.4 m	<b>83'0"</b>	28.4 m	<b>83'0"</b>
Fuel Tank Refill Capacity	1137 L	<b>300 U.S. gal</b>	1137 L	<b>300 U.S. gal</b>	1137 L	<b>300 U.S. gal</b>
Top Speed (Loaded)	65.0 km/h	<b>40.4 mph</b>	67.0 km/h	<b>41.7 mph</b>	67.0 km/h	<b>41.7 mph</b>
<b>GENERAL DIMENSIONS (Empty):</b>						
Height to Canopy Rock Guard Rail	5.17 m	<b>17'0"</b>	4.91 m	<b>16'1"</b>	5.17 m	<b>17'0"</b>
Wheelbase	4.6 m	<b>15'0"</b>	4.6 m	<b>15'0"</b>	4.6 m	<b>15'0"</b>
Overall Length (Operating)	10.3 m	<b>33'8"</b>	10.3 m	<b>33'8"</b>	10.54 m	<b>34'7"</b>
Overall Length (Shipping)	9.78 m	<b>32'1"</b>	9.78 m	<b>32'1"</b>	9.78 m	<b>32'1"</b>
Loading Height (Empty)	4.39 m	<b>14'5"</b>	4.39 m	<b>14'5"</b>	4.38 m	<b>14'4"</b>
Height at Full Dump	10.05 m	<b>33'0"</b>	10.05 m	<b>33'0"</b>	10.33 m	<b>33'11"</b>
Body Length (Target Length)	7.28 m	<b>23'11"</b>	7.28 m	<b>23'11"</b>	7.28 m	<b>23'11"</b>
Width (Operating)	6.1 m	<b>20'0"</b>	6.1 m	<b>20'0"</b>	6.55 m	<b>21'6"</b>
Width (Shipping)***	3.51 m	<b>11'5"</b>	3.51 m	<b>11'5"</b>	3.51 m	<b>11'5"</b>
Front Tire Tread	4.17 m	<b>13'8"</b>	4.17 m	<b>13'8"</b>	4.17 m	<b>13'8"</b>

\*Weights include lubricants, coolants and 100% fuel.

\*\*Refer to Caterpillar's 10/10/20 Payload Policy for Off-Highway Trucks.

\*\*\*Disassembled.

\*\*\*\*India sourced, not available in all regions.

\*\*\*\*\*Gateless Coal Bodies are available through OEM Solutions.

<b>MODEL</b>	<b>777G****</b>		<b>777G****</b>	
Body Type	<b>Dual Slope</b>		<b>X-Body</b>	
Emission Standards	<b>Tier 2 equivalent</b>		<b>Tier 2 equivalent</b>	
Gross Machine Weight	164 654 kg	<b>363,000 lb</b>	164 654 kg	<b>363,000 lb</b>
Chassis Weight*	51 848 kg	<b>114,305 lb</b>	51 848 kg	<b>114,305 lb</b>
Body Weight	16 075 kg	<b>35,439 lb</b>	15 878 kg	<b>35,005 lb</b>
Payload without Liner	96 731 kg	<b>213,256 lb</b>	96 928 kg	<b>213,690 lb</b>
Standard Liner Weight	5695 kg	<b>12,555 lb</b>	4686 kg	<b>10,331 lb</b>
Target Payload**	91 036 kg	<b>200,711 lb</b>	92 242 kg	<b>203,359 lb</b>
Capacity:				
Struck (SAE)	42 m <sup>3</sup>	<b>54.6 yd<sup>3</sup></b>	42 m <sup>3</sup>	<b>54.6 yd<sup>3</sup></b>
Heaped (2:1) (SAE)	60.2 m <sup>3</sup>	<b>78.6 yd<sup>3</sup></b>	60.2 m <sup>3</sup>	<b>78.6 yd<sup>3</sup></b>
Distribution Empty:				
Front		<b>41.8%</b>		<b>41.8%</b>
Rear		<b>58.2%</b>		<b>58.2%</b>
Distribution Loaded:				
Front		<b>33%</b>		<b>33%</b>
Rear		<b>67%</b>		<b>67%</b>
Engine Model	<b>C32 ACERT</b>		<b>C32 ACERT</b>	
Number of Cylinders	<b>12</b>		<b>12</b>	
Bore	145 mm	<b>5.7"</b>	145 mm	<b>5.7"</b>
Stroke	162 mm	<b>6.4"</b>	162 mm	<b>6.4"</b>
Displacement	32.1 L	<b>1959 in<sup>3</sup></b>	32.1 L	<b>1959 in<sup>3</sup></b>
Net Power	704 kW	<b>945 hp</b>	704 kW	<b>945 hp</b>
Gross Power	765 kW	<b>1025 hp</b>	765 kW	<b>1025 hp</b>
Standard Tires	<b>27.00R49</b>		<b>27.00R49</b>	
Machine Clearance Turning Circle	28.4 m	<b>83'0"</b>	28.4 m	<b>83'0"</b>
Fuel Tank Refill Capacity	1137 L	<b>300 U.S. gal</b>	1137 L	<b>300 U.S. gal</b>
Top Speed (Loaded)	67.0 km/h	<b>41.7 mph</b>	67.0 km/h	<b>41.7 mph</b>
<b>GENERAL DIMENSIONS (Empty):</b>				
Height to Canopy Rock Guard Rail	4.91 m	<b>16'1"</b>	5.17 m	<b>17'0"</b>
Wheelbase	4.6 m	<b>15'0"</b>	4.6 m	<b>15'0"</b>
Overall Length (Operating)	10.3 m	<b>33'8"</b>	10.54 m	<b>34'7"</b>
Overall Length (Shipping)	9.78 m	<b>32'1"</b>	9.78 m	<b>32'1"</b>
Loading Height (Empty)	4.39 m	<b>14'5"</b>	4.38 m	<b>14'4"</b>
Height at Full Dump	10.05 m	<b>33'0"</b>	10.33 m	<b>33'11"</b>
Body Length (Target Length)	7.28 m	<b>23'11"</b>	7.28 m	<b>23'11"</b>
Width (Operating)	6.1 m	<b>20'0"</b>	6.55 m	<b>21'6"</b>
Width (Shipping)***	3.51 m	<b>11'5"</b>	3.51 m	<b>11'5"</b>
Front Tire Tread	4.17 m	<b>13'8"</b>	4.17 m	<b>13'8"</b>

\*Weights include lubricants, coolants and 100% fuel.

\*\*Refer to Caterpillar's 10/10/20 Payload Policy for Off-Highway Trucks.

\*\*\*Disassembled.

\*\*\*\*Gateless Coal Bodies are available through OEM Solutions.

MODEL	785C		785D		789D	
Body Type	<b>Dual Slope</b>		<b>Dual Slope</b>		<b>Dual Slope</b>	
Target Gross Machine Weight ‡	249 476 kg	<b>550,000 lb</b>	249 476 kg	<b>550,000 lb</b>	324 319 kg	<b>715,000 lb</b>
Basic Machine Weight*	59 385 kg	<b>130,922 lb</b>	46 240 kg	<b>101,942 lb</b>	48 554 kg	<b>107,043 lb</b>
Attachments**	21 602 kg	<b>47,624 lb</b>	35 781 kg	<b>78,885 lb</b>	52 249 kg	<b>115,190 lb</b>
Body Weight without Liners***	22 997 kg	<b>50,700 lb</b>	22 997 kg	<b>50,700 lb</b>	26 606 kg	<b>58,656 lb</b>
Full Liner	8113 kg	<b>17,886 lb</b>	8113 kg	<b>17,886 lb</b>	9692 kg	<b>21,367 lb</b>
Operating Machine Weight	112 097 kg	<b>247,132 lb</b>	113 131 kg	<b>249,412 lb</b>	137 101 kg	<b>302,256 lb</b>
Debris (3% of Operating Machine Weight)	3363 kg	<b>7414 lb</b>	3394 kg	<b>7482 lb</b>	4113 kg	<b>9068 lb</b>
Empty Operating Weight	115 460 kg	<b>254,546 lb</b>	116 525 kg	<b>256,894 lb</b>	141 214 kg	<b>311,324 lb</b>
Target Payload ‡	134.0 m tons	<b>147.7 tons</b>	133.0 m tons	<b>146.6 tons</b>	183.1 m tons	<b>201.8 tons</b>
Capacity:						
Heaped (2:1) (SAE) Base Body	78 m <sup>3</sup>	<b>102 yd<sup>3</sup></b>	78 m <sup>3</sup>	<b>102 yd<sup>3</sup></b>	108 m <sup>3</sup>	<b>141 yd<sup>3</sup></b>
Heaped (2:1) (SAE) with Std. Sideboards	91 m <sup>3</sup>	<b>119 yd<sup>3</sup></b>	91 m <sup>3</sup>	<b>119 yd<sup>3</sup></b>	125 m <sup>3</sup>	<b>161 yd<sup>3</sup></b>
Distribution Empty:						
Front		<b>45%</b>		<b>45.5%</b>		<b>46%</b>
Rear		<b>55%</b>		<b>54.5%</b>		<b>54%</b>
Distribution Loaded:						
Front		<b>33.3%</b>		<b>33.3%</b>		<b>33%</b>
Rear		<b>66.7%</b>		<b>66.7%</b>		<b>66%</b>
Engine Model	<b>3512B EUI</b>		<b>3512C HD-EUI</b>		<b>3516C HD</b>	
Number of Cylinders	<b>12</b>		<b>12</b>		<b>16</b>	
Bore	170 mm	<b>6.7"</b>	170 mm	<b>6.7"</b>	170 mm	<b>6.7 in</b>
Stroke	190 mm	<b>7.5"</b>	215 mm	<b>8.46"</b>	210 mm	<b>8.3 in</b>
Displacement	51.8 L	<b>3158 in<sup>3</sup></b>	58.56 L	<b>3574 in<sup>3</sup></b>	78.1 L	<b>4766 in<sup>3</sup></b>
Net Power	979 kW	<b>1313 hp</b>	979 kW	<b>1313 hp</b>	1468 kW	<b>1969 hp</b>
Gross Power	1082 kW	<b>1450 hp</b>	1082 kW	<b>1450 hp</b>	1566 kW	<b>2100 hp</b>
Standard Tires	<b>33.00R51</b>		<b>33.00R51</b>		<b>37.00R57</b>	
Machine Clearance	30.6 m	<b>100'5"</b>	33.2 m	<b>108'11"</b>	30.23 m	<b>99'2"</b>
Fuel Tank Refill Capacity	1893 L	<b>500 U.S. gal</b>	1893 L	<b>500 U.S. gal</b>	2082 L	<b>550 U.S. gal</b>
Top Speed (Loaded)	56.5 km/h	<b>35.1 mph</b>	56.5 km/h	<b>35.1 mph</b>	57.2 km/h	<b>35.5 mph</b>
<b>GENERAL DIMENSIONS (Empty):</b>						
Height to Canopy Rock Guard Rail	5.77 m	<b>19'0"</b>	5.68 m	<b>18'7"</b>	6.50 m	<b>21'4"</b>
Wheelbase	5.18 m	<b>17'0"</b>	5.18 m	<b>17'0"</b>	5.70 m	<b>18'8"</b>
Overall Length (Base Body)	11.02 m	<b>36'3"</b>	11.55 m	<b>37'9"</b>	12.72 m	<b>41'9"</b>
Loading Height (Base Body)	4.97 m	<b>16'4"</b>	4.97 m	<b>16'4"</b>	5.60 m	<b>18'4"</b>
Height at Full Dump	11.21 m	<b>36'10"</b>	11.81 m	<b>38'9"</b>	13.20 m	<b>43'4"</b>
Body Length (Target Length)	7.65 m	<b>25'2"</b>	7.65 m	<b>25'2"</b>	8.29 m	<b>27'3"</b>
Width (Operating)	6.64 m	<b>21'10"</b>	7.06 m	<b>23'2"</b>	7.65 m	<b>25'1"</b>
Width (Shipping)****	3.91 m	<b>12'10"</b>	3.91 m	<b>12'10"</b>	3.84 m	<b>12'7"</b>
Front Tire Tread	4.85 m	<b>15'11"</b>	4.85 m	<b>15'11"</b>	5.37 m	<b>17'8"</b>

\*See Weight Definitions and Relations on page 18 of this section. Note: No mandatory or optional attachments or fuel.

\*\*Typical selection of mandatory and optional attachments.

\*\*\*Data provided is for a representative body and liner package. Several dual slope, flat floor, and mine specific design (MSD) bodies and liner packages are available. All weights, capacities, and dimensions are dependent on the machine configuration (body type, attachments, tires, and optional equipment selected).

\*\*\*\*Disassembled.

‡Reference Caterpillar's latest 10/10/20 Payload Policy for information on gross machine operating weight and target payload.

**NOTE:** Contact Mining Representative to use Caterpillar Weight Configurator for application specific weights.

MODEL	793D Standard		793D XLWS	
Body Type	MSD II		MSD II	
Target Gross Machine Weight §	383 740 kg	<b>846,000 lb</b>	383 740 kg	<b>846,000 lb</b>
Basic Machine Weight*	51 135 kg	<b>112,734 lb</b>	51 310 kg	<b>113,119 lb</b>
Attachments**	65 898 kg	<b>145,281 lb</b>	67 514 kg	<b>148,844 lb</b>
Body Weight without Liners***	26 980 kg	<b>59,481 lb</b>	26 980 kg	<b>59,481 lb</b>
Full Liner	6209 kg	<b>13,688 lb</b>	6209 kg	<b>13,688 lb</b>
Operating Machine Weight	150 223 kg	<b>331,184 lb</b>	152 013 kg	<b>335,132 lb</b>
Debris (3% of Operating Machine Weight)	4507 kg	<b>9936 lb</b>	4560 kg	<b>10,054 lb</b>
Empty Operating Weight	154 729 kg	<b>341,119 lb</b>	156 574 kg	<b>345,186 lb</b>
Target Payload §	229.0 m tons	<b>252.4 tons</b>	227.2 m tons	<b>250.4 tons</b>
Capacity:				
Heaped (2:1) (SAE) Base Body	176 m <sup>3</sup>	<b>230 yd<sup>3</sup></b>	176 m <sup>3</sup>	<b>230 yd<sup>3</sup></b>
Distribution Empty:				
Front		<b>46.2%</b>		<b>46%</b>
Rear		<b>53.8%</b>		<b>54%</b>
Distribution Loaded:				
Front		<b>33.3%</b>		<b>33.3%</b>
Rear		<b>66.7%</b>		<b>66.7%</b>
Engine Model	<b>3516B HD EUI</b>		<b>3516B HD EUI</b>	
Number of Cylinders	<b>16</b>		<b>16</b>	
Bore	170 mm	<b>6.7"</b>	170 mm	<b>6.7"</b>
Stroke	215 mm	<b>8.5"</b>	215 mm	<b>8.5"</b>
Displacement	78 L	<b>4760 in<sup>2</sup></b>	78 L	<b>4760 in<sup>2</sup></b>
Net Power	1694 kW	<b>2273 hp</b>	1694 kW	<b>2273 hp</b>
Gross Power	1801 kW	<b>2415 hp</b>	1801 kW	<b>2415 hp</b>
Standard Tires	<b>40/00R57</b>		<b>40/00R57</b>	
Machine Clearance Turning Circle	33 m	<b>107'0"</b>	33 m	<b>107'0"</b>
Fuel Tank Refill Capacity	4353 L	<b>1150 U.S. gal</b>	4353 L	<b>1150 U.S. gal</b>
Top Speed (Loaded)	59.9 km/h	<b>37.2 mph</b>	59.9 km/h	<b>37.2 mph</b>
<b>GENERAL DIMENSIONS (Empty):</b>				
Height to Canopy Rock Guard Rail	6.6 m	<b>21'8"</b>	6.6 m	<b>21'8"</b>
Wheelbase	5.91 m	<b>19'5"</b>	5.91 m	<b>19'5"</b>
Overall Length (Base Body)	13.01 m	<b>42'9"</b>	13.01 m	<b>42'9"</b>
Loading Height (Base Body)	6.5 m	<b>21'5"</b>	6.5 m	<b>21'5"</b>
Height at Full Dump	13.25 m	<b>43'6"</b>	13.25 m	<b>43'6"</b>
Body Length (Target Length)	8.99 m	<b>29'6"</b>	8.99 m	<b>29'6"</b>
Width (Operating)	8.3 m	<b>27'3"</b>	8.3 m	<b>27'3"</b>
Width (Shipping)****	4.1 m	<b>13'5"</b>	4.1 m	<b>13'5"</b>
Front Tire Tread	5.63 m	<b>18'6"</b>	5.63 m	<b>18'6"</b>

\*See Weight Definitions and Relations on page 18 of this section. Note: No mandatory or optional attachments or fuel.

\*\*Typical selection of mandatory and optional attachments.

\*\*\*Data provided for the 793D Standard (MA1) is for a representative body and liner package. Several dual slope, flat floor, and mine specific design (MSD) bodies and liner packages are available. All weights, capacities, and dimensions are dependent on the machine configuration (body type, attachments, tires, and optional equipment selected).

\*\*\*\*Disassembled.

§Reference Caterpillar's latest 10/10/20 Payload Policy for information on gross machine operating weight and target payload.

**NOTE:** Contact Mining Representative to use Caterpillar Weight Configurator for application specific weights.



MODEL	793F Standard		793F XLP	
	MSD II		MSD II	
Body Type				
Target Gross Machine Weight ‡	386 008 kg	<b>851,000 lb</b>	390 090 kg	<b>860,000 lb</b>
Basic Machine Weight*	42 638 kg	<b>94,001 lb</b>	42 638 kg	<b>94,001 lb</b>
Attachments**	79 381 kg	<b>175,005 lb</b>	84 594 kg	<b>186,498 lb</b>
Body Weight without Liners***	26 893 kg	<b>59,289 lb</b>	26 893 kg	<b>59,289 lb</b>
Full Liner	6209 kg	<b>13,688 lb</b>	6209 kg	<b>13,688 lb</b>
Operating Machine Weight	155 121 kg	<b>341,983 lb</b>	160 334 kg	<b>353,476 lb</b>
Debris (3% of Operating Machine Weight)	4654 kg	<b>10,259 lb</b>	4810 kg	<b>10,604 lb</b>
Empty Operating Weight	159 775 kg	<b>352,242 lb</b>	165 144 kg	<b>364,080 lb</b>
Target Payload ‡	226.2 m tons	<b>249.4 tons</b>	224.9 m tons	<b>248.0 tons</b>
Capacity:				
Heaped (2:1) (SAE) Base Body	176 m <sup>3</sup>	<b>230 yd<sup>3</sup></b>	176 m <sup>3</sup>	<b>230 yd<sup>3</sup></b>
Distribution Empty:				
Front		<b>47.6%</b>		<b>47.3%</b>
Rear		<b>52.4%</b>		<b>52.7%</b>
Distribution Loaded:				
Front		<b>33.3%</b>		<b>33.3%</b>
Rear		<b>66.7%</b>		<b>66.7%</b>
Engine Model	<b>C175-16</b>		<b>C175-16</b>	
Number of Cylinders	<b>16</b>		<b>16</b>	
Bore	175 mm	<b>6.9"</b>	175 mm	<b>6.9"</b>
Stroke	220 mm	<b>8.7"</b>	220 mm	<b>8.7"</b>
Displacement	85 L	<b>5187 in<sup>3</sup></b>	85 L	<b>5187 in<sup>3</sup></b>
Net Power	1848 kW	<b>2478 hp</b>	1848 kW	<b>2478 hp</b>
Gross Power	1976 kW	<b>2650 hp</b>	1976 kW	<b>2650 hp</b>
Standard Tires	<b>40/00R57</b>		<b>46/90R57</b>	
Machine Clearance Turning Circle	33 m	<b>107'0"</b>	33 m	<b>107'0"</b>
Fuel Tank Refill Capacity	2839 L	<b>750 U.S. gal</b>	2839 L	<b>750 U.S. gal</b>
Top Speed (Loaded)	60.4 km/h	<b>37.6 mph</b>	60.4 km/h	<b>37.6 mph</b>
<b>GENERAL DIMENSIONS (Empty):</b>				
Height to Canopy Rock Guard Rail	6.6 m	<b>21'8"</b>	6.6 m	<b>21'8"</b>
Wheelbase	5.91 m	<b>19'5"</b>	5.91 m	<b>19'5"</b>
Overall Length (Base Body)	13.7 m	<b>44'11"</b>	13.7 m	<b>44'11"</b>
Loading Height (Base Body)	6.5 m	<b>21'5"</b>	6.5 m	<b>21'5"</b>
Height at Full Dump	13.9 m	<b>45'6"</b>	13.9 m	<b>45'6"</b>
Body Length (Target Length)	8.99 m	<b>29'6"</b>	8.99 m	<b>29'6"</b>
Width (Operating)	8.3 m	<b>27'3"</b>	8.3 m	<b>27'3"</b>
Width (Shipping)****	4.1 m	<b>13'5"</b>	4.1 m	<b>13'5"</b>
Front Tire Tread	5.63 m	<b>18'6"</b>	5.63 m	<b>18'6"</b>

\*See Weight Definitions and Relations on page 18 of this section. Note: No mandatory or optional attachments or fuel.

\*\*Typical selection of mandatory and optional attachments.

\*\*\*Data provided is for a representative body and liner package. Several dual slope, flat floor, and mine specific design (MSD) bodies and liner packages are available. All weights, capacities, and dimensions are dependent on the machine configuration (body type, attachments, tires, and optional equipment selected).

\*\*\*\*Disassembled.

‡Reference Caterpillar's latest 10/10/20 Payload Policy for information on gross machine operating weight and target payload.

**NOTE:** Contact Mining Representative to use Caterpillar Weight Configurator for application specific weights.

MODEL	794 AC		795F AC		797F	
Body Type	HE Body		MSD II		MSD II	
Target Gross Machine Weight ‡	521 631 kg	<b>1,150,000 lb</b>	570 166 kg	<b>1,257,000 lb</b>	623 690 kg	<b>1,375,000 lb</b>
Basic Machine Weight*	122 031 kg	<b>269,032 lb</b>	118 807 kg	<b>261,924 lb</b>	86 412 kg	<b>190,506 lb</b>
Attachments**	37 409 kg	<b>82,472 lb</b>	79 503 kg	<b>175,273 lb</b>	128 083 kg	<b>282,374 lb</b>
Body Weight without Liners***	28 186 kg	<b>62,140 lb</b>	38 663 kg	<b>85,237 lb</b>	44 275 kg	<b>97,610 lb</b>
Full Liner†	—		7623 kg	<b>16,806 lb</b>	7652 kg	<b>16,870 lb</b>
Operating Machine Weight	217 419 kg	<b>479,327 lb</b>	244 596 kg	<b>539,240 lb</b>	266 422 kg	<b>587,359 lb</b>
Debris (3% of Operating Machine Weight)	—		7338 kg	<b>16,177 lb</b>	7993 kg	<b>17,621 lb</b>
Empty Operating Weight	217 419 kg	<b>479,327 lb</b>	251 933 kg	<b>555,417 lb</b>	274 415 kg	<b>604,980 lb</b>
Target Payload ‡	291 m tons	<b>320 tons</b>	313-317 m tons	<b>345-350 tons</b>	335-363 m tons	<b>370-400 tons</b>
Capacity:						
Heaped (2:1) (SAE) Base Body	180-222 m <sup>3</sup>	<b>236-290 yd<sup>3</sup></b>	213 m <sup>3</sup>	<b>280 yd<sup>3</sup></b>	240-267 m <sup>3</sup>	<b>315-350 yd<sup>3</sup></b>
Distribution Empty:						
Front		<b>49.0%</b>		<b>48%</b>		<b>45.7%</b>
Rear		<b>51.0%</b>		<b>52%</b>		<b>54.3%</b>
Distribution Loaded:						
Front		<b>33.0%</b>		<b>33%</b>		<b>33.3%</b>
Rear		<b>67.0%</b>		<b>67%</b>		<b>66.7%</b>
Engine Model	<b>C175-16</b>		<b>C175-16</b>		<b>C175-20</b>	
Number of Cylinders	<b>16</b>		<b>16</b>			
Bore	175 mm	<b>6.9"</b>	175 mm	<b>6.9"</b>	175 mm	<b>6.9"</b>
Stroke	220 mm	<b>8.7"</b>	220 mm	<b>8.7"</b>	220 mm	<b>8.7"</b>
Displacement	85 L	<b>5187 in<sup>3</sup></b>	85 L	<b>5187 in<sup>3</sup></b>	106 L	<b>6469 in<sup>3</sup></b>
Net Power	—		—		2830 kW	<b>3795 hp</b>
Gross Power	2051-2610 kW	<b>2750-3500 hp</b>	2535 kW	<b>3400 hp</b>	2983 kW	<b>4000 hp</b>
Standard Tires	<b>53/80R63</b>		<b>56/80R63</b>		<b>59/80R63</b>	
Machine Clearance Turning Circle	32.4 m	<b>106'0"</b>	38.7 m	<b>127'0"</b>	42.1 m	<b>138'1"</b>
Fuel Tank Refill Capacity	4922 L	<b>1300 U.S. gal</b>	7192 L	<b>1900 U.S. gal</b>	7571 L	<b>2000 U.S. gal</b>
Top Speed (Loaded)	60 km/h	<b>37 mph</b>	64 km/h	<b>40 mph</b>	67.9 km/h	<b>42.2 mph</b>
<b>GENERAL DIMENSIONS (Empty):</b>						
Height to Canopy Rock Guard Rail	7.59 m	<b>24'11"</b>	7.80 m	<b>25'8"</b>	7.71 m	<b>25'4"</b>
Wheelbase	6.65 m	<b>21'10"</b>	6.73 m	<b>22'1"</b>	7.20 m	<b>23'7"</b>
Overall Length (Base Body)	15.47 m	<b>50'9"</b>	15.15 m	<b>49'9"</b>	15.08 m	<b>48'9"</b>
Loading Height (Base Body)	6.71 m	<b>22'2"</b>	—		7.00 m	<b>23'0"</b>
Loading Height (Empty)	—		7.04 m	<b>23'2"</b>	—	
Height at Full Dump	14.75 m	<b>48'5"</b>	15.06 m	<b>49'6"</b>	15.70 m	<b>51'6"</b>
Body Length (Target Length)	10.21 m	<b>33'6"</b>	15.15 m	<b>49'9"</b>	9.98 m	<b>32'6"</b>
Width (Operating)	9.09 m	<b>29'10"</b>	8.97 m	<b>29'6"</b>	9.76 m	<b>32'0"</b>
Width (Shipping)	9.09 m	<b>29'10"</b>	8.97 m	<b>29'6"</b>	9.76 m	<b>32'0"</b>
Front Tire Tread	7.04 m	<b>23'1"</b>	6.24 m	<b>20'6"</b>	6.53 m	<b>20'5"</b>

\*See Weight Definitions and Relations on page 18 of this section. Note: No mandatory or optional attachments or fuel.

\*\*Typical selection of mandatory and optional attachments.

\*\*\*Data provided is for a representative body and liner package. Several dual slope, flat floor, and mine specific design (MSD) bodies and liner packages are available. All weights, capacities, and dimensions are dependent on the machine configuration (body type, attachments, tires, and optional equipment selected).

‡Reference Caterpillar's latest 10/10/20 Payload Policy for information on gross machine operating weight and target payload.

†Liner used for 797F is a 1/3 solid liner.

**NOTE:** Contact Mining Representative to use Caterpillar Weight Configurator for application specific weights.

**TRUCK WEIGHT DEFINITIONS**

Target Gross Machine Weight	<ul style="list-style-type: none"> <li>- Loaded operating machine weight</li> <li>- Optimum productivity and cost per ton</li> <li>- Used for performance curves and calculations</li> </ul>
Basic Machine Weight	Basic chassis weight including shipping fluids, but no attachments, options, body, or tires
Attachments	Combined weight of mandatory attachments and a minimal representation of optional attachments
Body Weight without Liners	Representative weight of body called out in Body Type
Full Liner	Weight of solid steel full liner package for selected Body Type
Standard Sideboard	Weight of appropriate sideboard for selected Body Type and Model
Operating Machine Weight	Basic machine weight plus full fuel, tires, rims, selected attachments, operator, and body
Debris	2%–8% of operating machine weight depending on application
Empty Operating Weight	Operating machine weight plus debris
Target Payload	Target gross machine weight minus empty operating weight

**TRUCK WEIGHT RELATIONS\***

Operating Machine Weight	Operating Machine Weight = Basic Machine Weight + Attachments + Body Weight without Liners + Full Liner + Standard Sideboard
Empty Operating Weight	Empty Operating Weight = Operating Machine Weight + Debris
Target Payload	Target Payload = Target Gross Machine Weight – Empty Operating Weight
Target Gross Machine Weight	TGMW
Basic Machine Weight	BMW
Operating Machine Weight	OMW
Empty Operating Weight	EOW
Target Payload	TP

\*Reference Caterpillar’s latest 10/10/20 Payload Policy.

MODEL TIRE SIZE	PLY RATING/ STAR RATING*	TYPE	MODEL TIRE SIZE	PLY RATING/ STAR RATING*	TYPE
<b>770, 770G</b>			<b>789D</b>		
18.00R33	★★	E-3	37.00R57	★★	E-4
18.00R33◀	★★	E-4	40.00R57	★★	E-4
<b>772, 772G</b>			<b>793D</b>		
21.00R33◀	★★	E-4	40.00-57	68	E-4
<b>773E</b>			46-90R57	★★	E-4
24.00-35	42	E-4	<b>793F</b>		
24.00R35	★★	E-3	40.00-57	68	E-4
<b>773G</b>			46/90R57	★★	E-4
24.00-35	36	E-4	50/80R57	★★	E-4
24.00-35	42	E-4	<b>794 AC</b>		
24.00R35	★★	E-3	53/80R63	★★	E-4
24.00R35◀	★★	E-4	<b>795F AC</b>		
<b>775G</b>			56/80R63**	★★	E-4
24.00R35◀	★★	E-4	59/80R63***	★★	E-4
24.00R35	★★	E-3	<b>797F</b>		
24.00-35	48	E-4	59/80R63	★★	E-4
<b>777E, 777G</b>					
27.00R49	★★	E-3			
27.00R49◀	★★	E-3			
27.00-49	48	E-4			
<b>785C, 785D</b>					
33.00R51	★★	E-3			
33.00R51	★★	E-4			

\*Manufacturer uses star (★) rating system instead of ply rating.

\*\*Michelin ONLY.

\*\*\*Bridgestone and Goodyear ONLY.

◀No charge tire.

**USE OF BRAKE PERFORMANCE CURVES**

The speed that can be maintained when the machine is descending a grade with retarder applied can be determined from the retarder curves in this section when gross machine weight and total effective grade are known.

Select appropriate grade distance chart that covers total downhill haul; don't break haul into individual segments.

To determine brake performance: Read from gross weight down to the percent effective grade. (Effective grade equals actual % grade *minus* 1% for each 10 kg/metric ton (20 lb/U.S. ton) of rolling resistance.) From this weight-effective grade point, read horizontally to the curve with the highest obtainable speed range, then down to maximum descent speed brakes can safely handle without exceeding cooling capacity. When braking, engine RPM should be maintained at the highest possible level without overspeeding. If cooling oil overheats, reduce ground speed to allow transmission to shift to next lower speed range.

Brake Performance Curves are made in compliance with ISO 10268 and applicable to Sea Level and 32° C (90° F) temperature. Contact Factory for Application Specific Performance.

**USE OF RIMPULL-SPEED-  
GRADEABILITY CURVES**

For best results, use Caterpillar Fleet Production and Cost Analysis (FPC) to simulate cycle time, fuel burn, and production for Application Specific Performance inquiries. Contact Factory Representative or visit [catminer.cat.com/stb](http://catminer.cat.com/stb) for more information.

(See Wheel Tractor Scraper Section)

**Total Effective Grade** (or Total Resistance) is grade assistance *minus* rolling resistance.

10 kg/metric ton (20 lb/U.S. ton) = 1% adverse grade.

*Example —*

With a favorable grade of 20% and rolling resistance of 50 kg/metric ton (100 lb/U.S. ton), find Total Effective Grade.

$$\begin{aligned}
 (50 \text{ kg/metric ton}) &= 50 \div 10 = 5\% \text{ Effective Grade} \\
 &\quad \text{(from Rolling Resistance)} \\
 100 \text{ lb/ton} &= 100 \div 20 = 5\% \text{ Effective Grade} \\
 20\% \text{ (grade)} - 5\% \text{ (resistance)} &= \\
 15\% \text{ Total Effective Grade} &
 \end{aligned}$$

**TYPICAL FIXED TIMES FOR HAULING UNITS**

Wait time, delays and operator efficiency all impact cycle time. Minimizing truck exchange time can have a significant effect on productivity.

Fixed time for hauling units include:

1. Truck load time (various with loading tool)
2. Truck maneuver in load area (Truck exchange) (Typically 0.6-0.8 min.)
3. Maneuver and dump time at dump point (Typically 1.0-1.2 min.)

Total cycle time is the combination of:

1. The above fixed time
2. Hauling time (Loaded)
3. Return time (Empty)

*Example — assume load tool spots hauler with full bucket*

	<b>988F</b>	<b>5130B</b>
cycle times	.60	.45
First pass (dump time)	.10 min.	.05 min.
2 passes (full cycle)	.70	.50
3 passes "	1.30	.95
4 passes "	1.90	1.40
5 passes "	2.50	1.85
6 passes "	3.10	2.30
7 passes "	3.70	2.75
8 passes "	4.30	3.20
9 passes "	4.90	3.65
10 passes "	5.40	4.10

**NOTE:** Other sizes of loading tools will have different cycle times. See Wheel Loader section for **average** cycle times for truck loading.

## MECHANICAL POWER TRAIN EFFICIENCIES

In selling against electric drive trucks, power train efficiency is an important consideration. To better illustrate the advantages of mechanical drive performance, grade horsepower, power train efficiency, and retarding horsepower should be compared to electric drive trucks.

Grade horsepower can be calculated by the following formula:

Metric

$$\text{grade HP} = \frac{\text{GMW (kg)} \times \text{TR} \times \text{Speed (km/h)}}{273.75}$$

English

$$= \frac{\text{GMW (lb)} \times \text{TR} \times \text{Speed (mph)}}{375}$$

where TR

(total resistance) = Rolling resistance + Grade resistance  
(expressed as a decimal)

English example

700,000 lb GMW, 2% rolling resistance, +8% actual grade at 8.2 mph would require 1530 HP

$$\frac{700,000 \times (.02 + .08) \times 8.2}{375} = 1530 \text{ HP}$$

Metric example

317 520 kg GMW, 2% rolling resistance, +8% actual grade at 13.2 km/h would require 1530 HP

$$\frac{317\,520 \times (.02 + .08) \times 13.2}{273.75} = 1530 \text{ HP}$$

We then calculate power train efficiency by dividing grade horsepower by the gross horsepower produced by the engine. Most electric drive trucks run at constant maximum horsepower while under load. Mechanical drive trucks, however, lug the engine and may produce somewhat less than maximum horsepower. Engine power curves must be utilized to determine exact horsepower produced.

Example

$$\frac{1530 \text{ grade horsepower}}{1800 \text{ gross engine HP}} \times 100 = 85\% \text{ power train efficiency}$$

This exercise illustrates the effect of an efficient mechanical drive power train and should yield results in the 80-85% efficiency range. The same calculation for electric drive trucks would be lower (70-78% range) with a maximum efficiency of about 78% for the most common systems.

Likewise, retarding horsepower being consumed by the retarding system can be calculated by the following formula:

Metric

$$\text{retarding HP} = \frac{\text{GMW (kg)} \times \text{TR} \times \text{Speed (km/h)}}{273.75}$$

English

$$= \frac{\text{GMW (lb)} \times \text{TR} \times \text{Speed (mph)}}{375}$$

where TR

(total resistance) = Rolling resistance + Grade resistance  
(expressed as a decimal)

English example

700,000 lb GMW, 2% rolling resistance, -8% actual grade at 14.7 mph would equate to -1646 HP

$$\frac{700,000 \times (.02 - .08) \times 14.7}{375} = 1646 \text{ HP}$$

Metric example

317 520 kg GMW, 2% rolling resistance, -8% actual grade at 23.6 km/h would equate to -1646 HP

$$\frac{317\,520 \times (.02 - .08) \times 23.6}{273.75} = 1646 \text{ HP}$$

This formula is intended for use in determining horsepower being consumed in the field based on field measurements. It is not intended to indicate how fast trucks should be operated on grade. Only job conditions, proper operating procedure, and good judgement should determine safe operating speeds during retarder use.

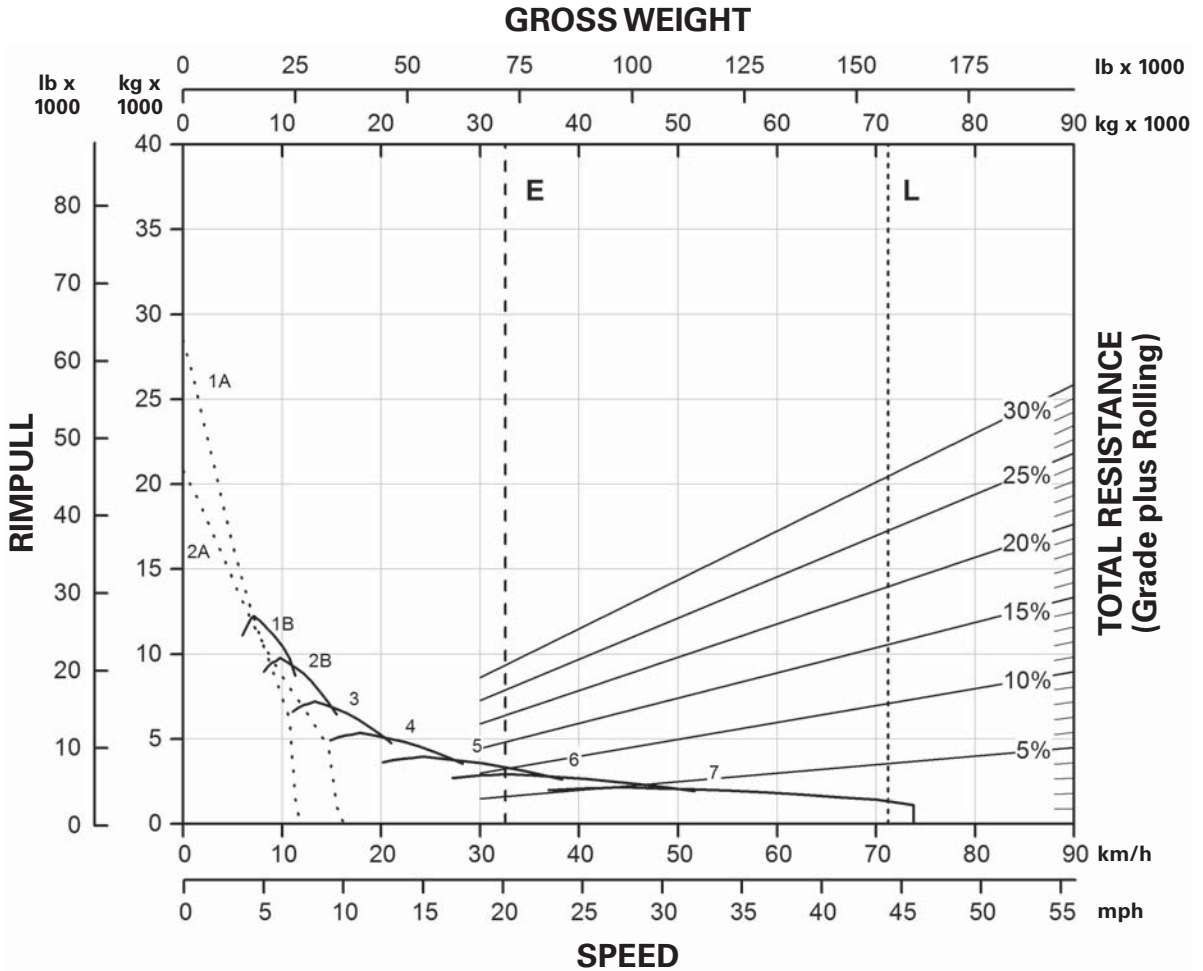

**KEY**

- 1A — 1st Gear (Torque Converter)
- 1B — 1st Gear
- 2 — 2nd Gear
- 3 — 3rd Gear
- 4 — 4th Gear
- 5 — 5th Gear
- 6 — 6th Gear
- 7 — 7th Gear

**KEY**

- E — Empty 33 224 kg (73,247 lb)
- L — Target GMW 71 214 kg (157,000 lb)

\*Meets Tier 4 Final, Stage IV, and Japan 2014 (Tier 4 Final) emission standards.

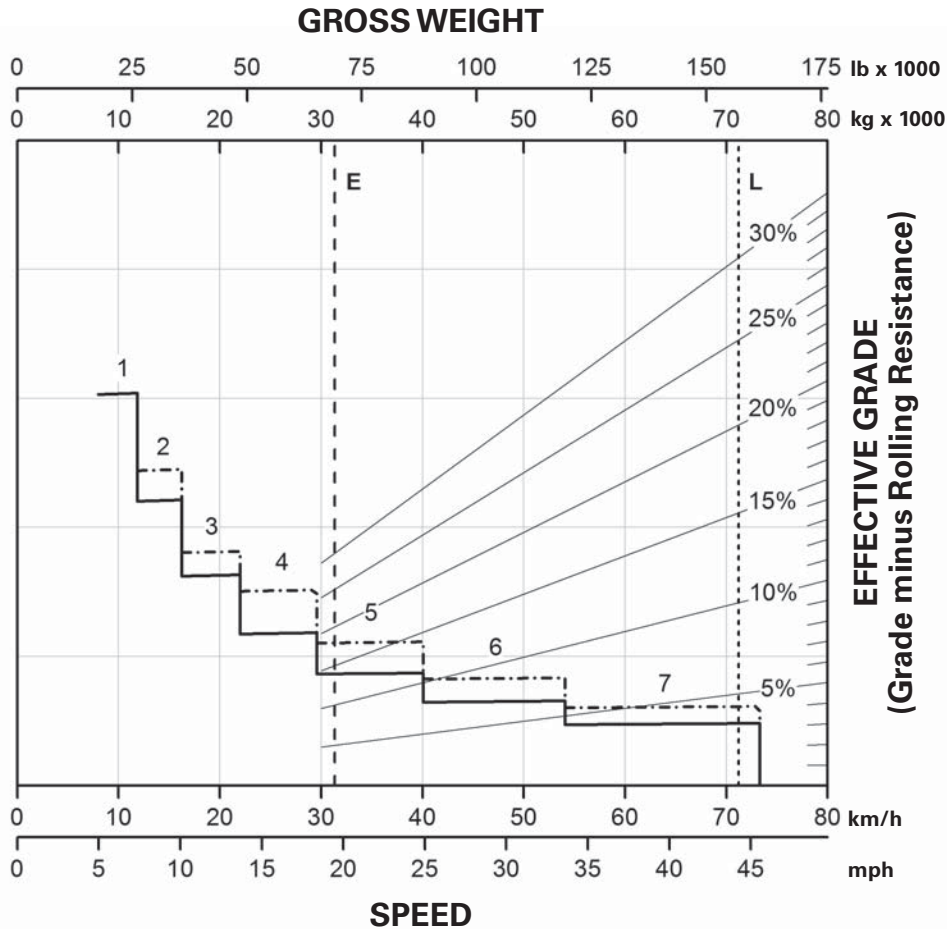

- KEY**
- 1 — 1st Gear
  - 2 — 2nd Gear
  - 3 — 3rd Gear
  - 4 — 4th Gear
  - 5 — 5th Gear
  - 6 — 6th Gear
  - 7 — 7th Gear

- KEY**
- E — Empty 33 224 kg (73,247 lb)
  - L — Target GMW 71 214 kg (157,000 lb)
  - With ARC Only
  - - - - - ARC and Engine Brake

\*Meets Tier 4 Final, Stage IV, and Japan 2014 (Tier 4 Final) emission standards.



# Mining & Off-Highway Trucks

## 770G\* Brake Performance

- 450 m (1500 ft)    ● 600 m (2000 ft)
- 900 m (3000 ft)    ● 1500 m (5000 ft)

### GROSS WEIGHT

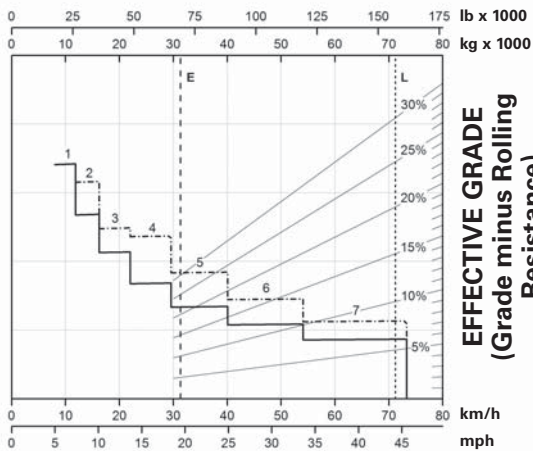

### SPEED

GRADE DISTANCE — 450 m (1500 ft)

### GROSS WEIGHT

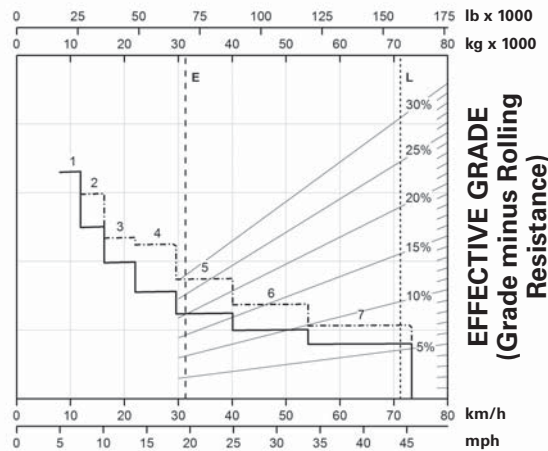

### SPEED

GRADE DISTANCE — 600 m (2000 ft)

### GROSS WEIGHT

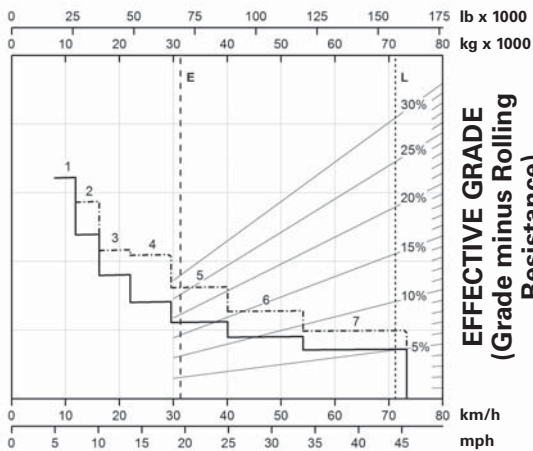

### SPEED

GRADE DISTANCE — 900 m (3000 ft)

### GROSS WEIGHT

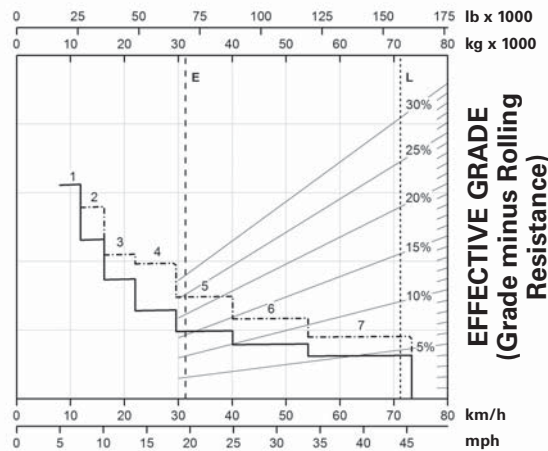

### SPEED

GRADE DISTANCE — 1500 m (5000 ft)

#### KEY

- 1 — 1st Gear
- 2 — 2nd Gear
- 3 — 3rd Gear
- 4 — 4th Gear
- 5 — 5th Gear
- 6 — 6th Gear
- 7 — 7th Gear

#### KEY

- E — Empty 33 224 kg (73,247 lb)
- L — Target GMW 71 214 kg (157,000 lb)
- With ARC Only
- - - - - ARC and Engine Brake

\*Meets Tier 4 Final, Stage IV, and Japan 2014 (Tier 4 Final) emission standards.

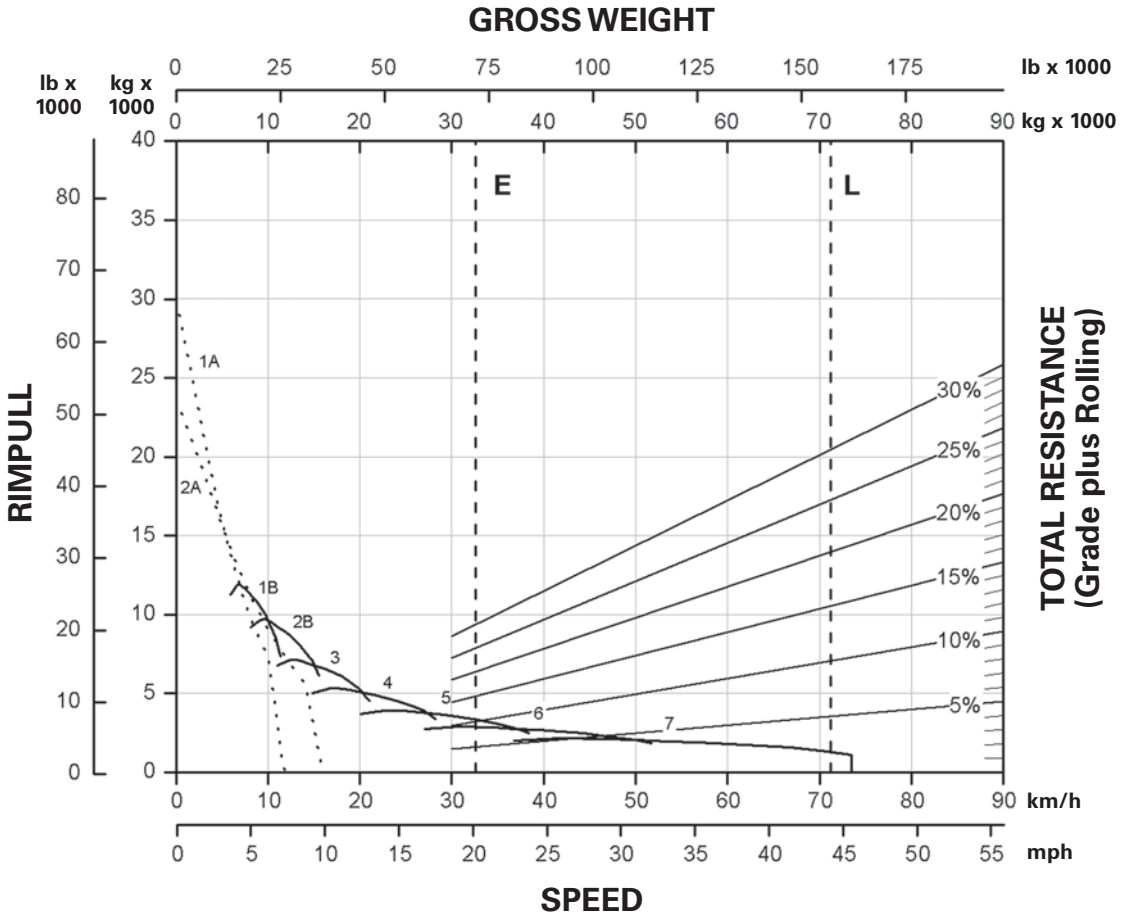

**KEY**

- 1A – 1st Gear (Torque Converter)
- 1B – 1st gear
- 2A – 2nd Gear (Torque Converter)
- 2B – 2nd Gear
- 3 – 3rd Gear
- 4 – 4th Gear
- 5 – 5th Gear
- 6 – 6th Gear
- 7 – 7th Gear

**KEY**

- E – Empty Weight 32 565 kg (71,793 lb)
- L – Target GMW 71 214 kg (157,000 lb)

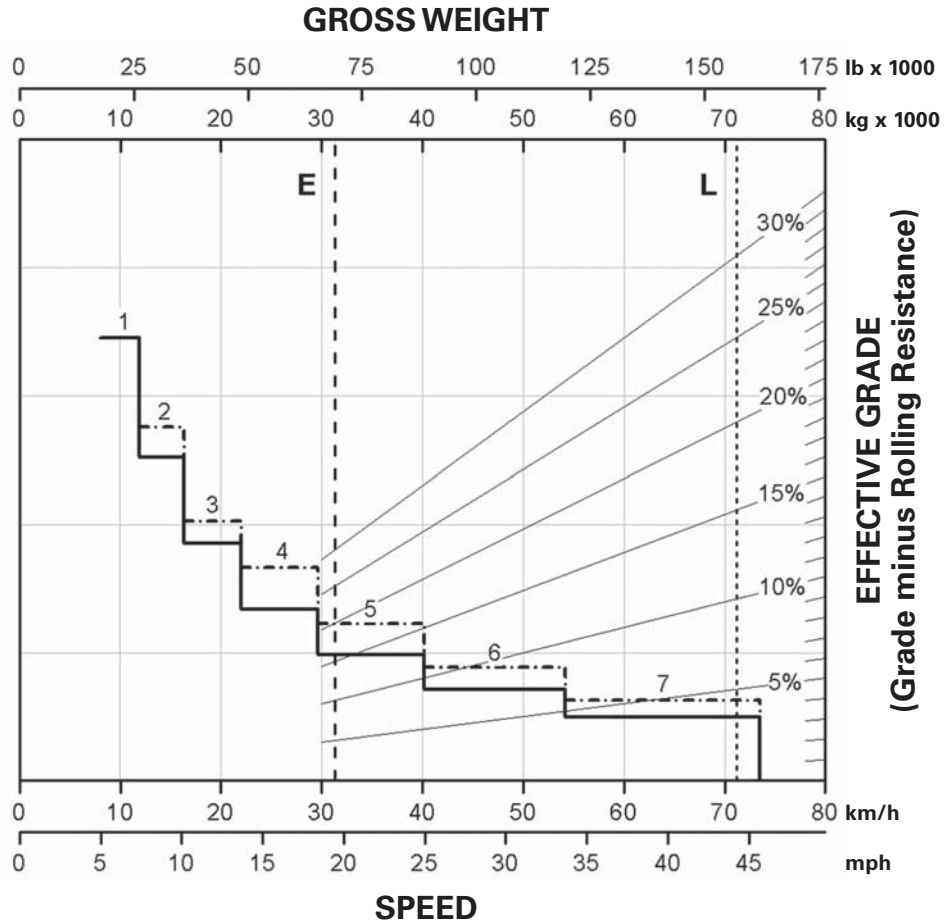

KEY

- 1 — 1st Gear
- 2 — 2nd Gear
- 3 — 3rd Gear
- 4 — 4th Gear
- 5 — 5th Gear
- 6 — 6th Gear
- 7 — 7th Gear

KEY

- E — Empty Weight 32 565 kg (71,793 lb)
- L — Target GMW 71 214 kg (157,000 lb)
- With ARC Only
- - - - - ARC and Engine Brake

770G Brake Performance

- 450 m (1500 ft)
- 600 m (2000 ft)
- 900 m (3000 ft)
- 1500 m (5000 ft)

GROSS WEIGHT

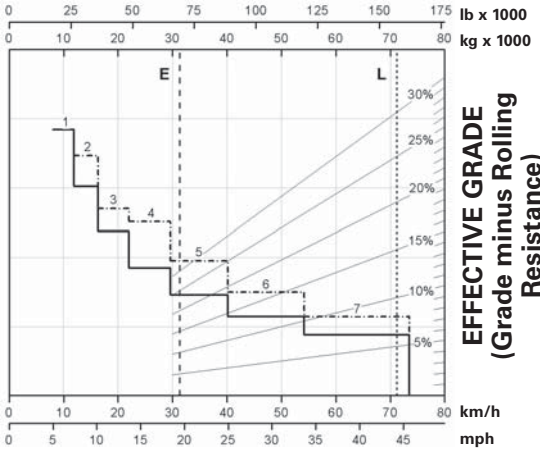

SPEED

GRADE DISTANCE — 450 m (1500 ft)

GROSS WEIGHT

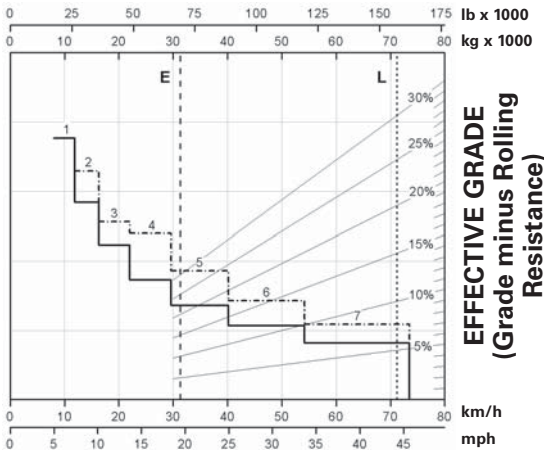

SPEED

GRADE DISTANCE — 600 m (2000 ft)

GROSS WEIGHT

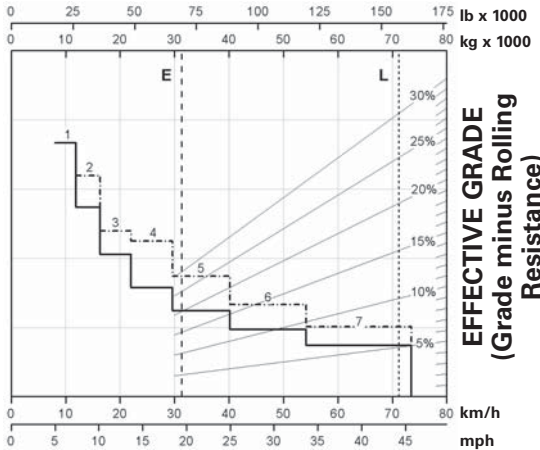

SPEED

GRADE DISTANCE — 900 m (3000 ft)

GROSS WEIGHT

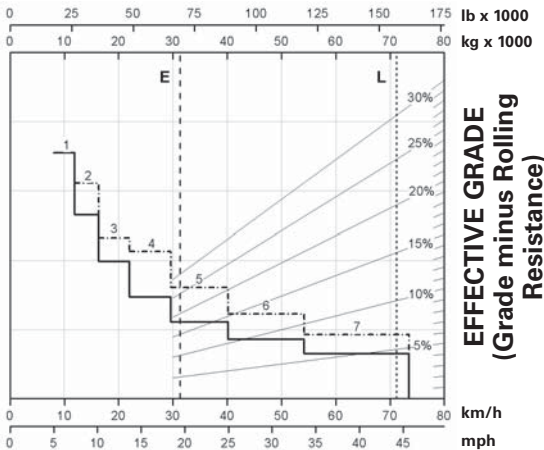

SPEED

GRADE DISTANCE — 1500 m (5000 ft)

KEY

- 1 — 1st Gear
- 2 — 2nd Gear
- 3 — 3rd Gear
- 4 — 4th Gear
- 5 — 5th Gear
- 6 — 6th Gear
- 7 — 7th Gear

KEY

- E — Empty Weight 32 565 kg (71,793 lb)
- L — Target GMW 71 214 kg (157,000 lb)
- With ARC Only
- - - - - ARC and Engine Brake

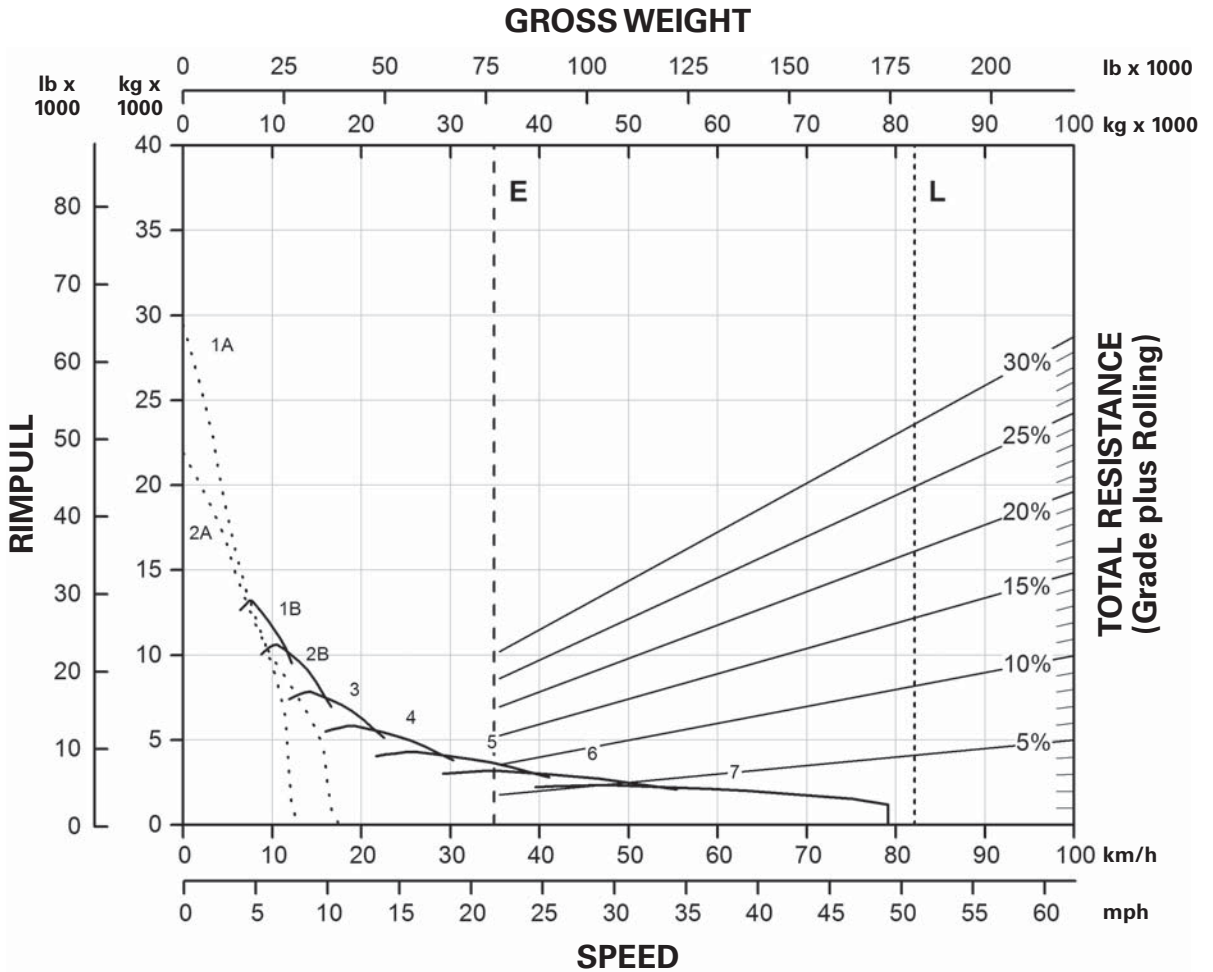

**KEY**

- 1A — 1st Gear (Torque Converter)
- 1B — 1st Gear
- 2 — 2nd Gear
- 3 — 3rd Gear
- 4 — 4th Gear
- 5 — 5th Gear
- 6 — 6th Gear
- 7 — 7th Gear

**KEY**

- E — Empty 34 893 kg (76,925 lb)
- L — Target GMW 82 100 kg (181,000 lb)

\*Meets Tier 4 Final, Stage IV, and Japan 2014 (Tier 4 Final) emission standards.

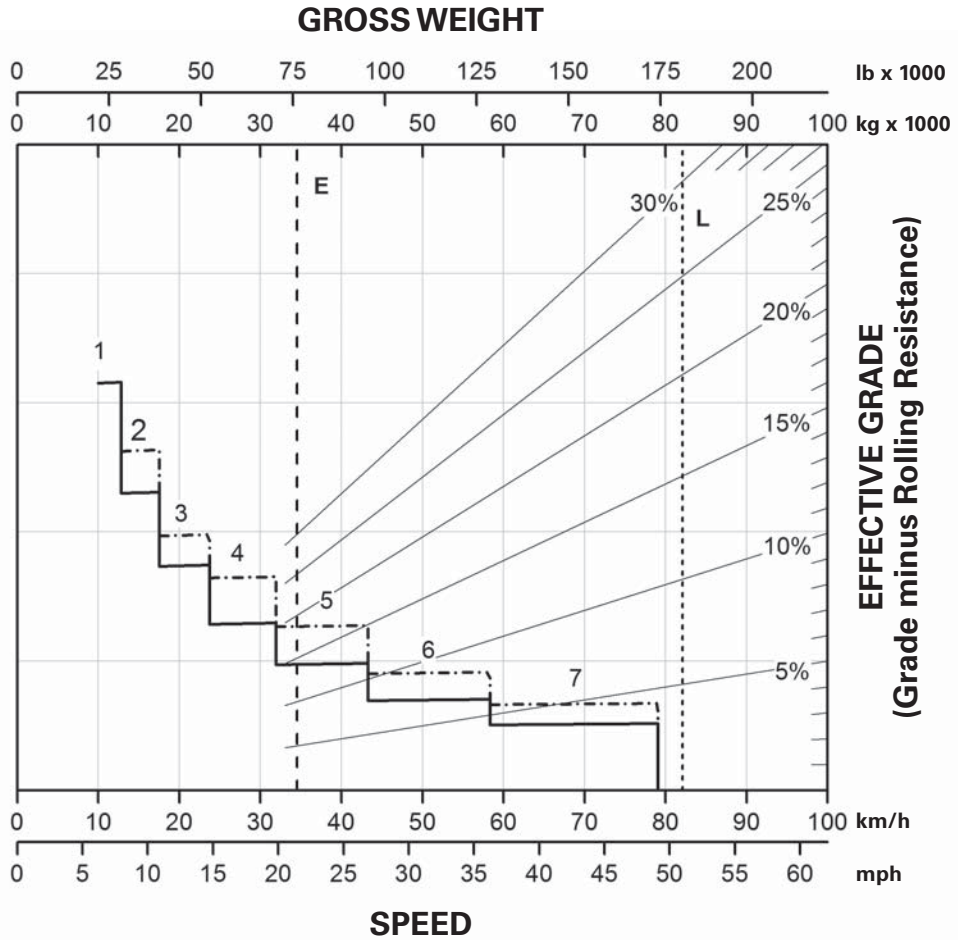

**CONTINUOUS GRADE LENGTH**

**KEY**

- 1 — 1st Gear
- 2 — 2nd Gear
- 3 — 3rd Gear
- 4 — 4th Gear
- 5 — 5th Gear
- 6 — 6th Gear
- 7 — 7th Gear

**KEY**

- E — Empty 34 893 kg (76,925 lb)
- L — Target GMW 82 100 kg (181,000 lb)
- With ARC Only
- - - - - ARC and Engine Brake

\*Meets Tier 4 Final, Stage IV, and Japan 2014 (Tier 4 Final) emission standards.

# Mining & Off-Highway Trucks

## 772G\* Brake Performance

- 450 m (1500 ft)
- 600 m (2000 ft)
- 900 m (3000 ft)
- 1500 m (5000 ft)

### GROSS WEIGHT

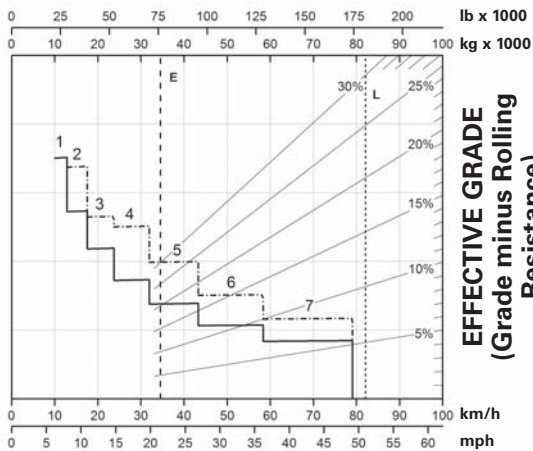

### SPEED

GRADE DISTANCE — 450 m (1500 ft)

### GROSS WEIGHT

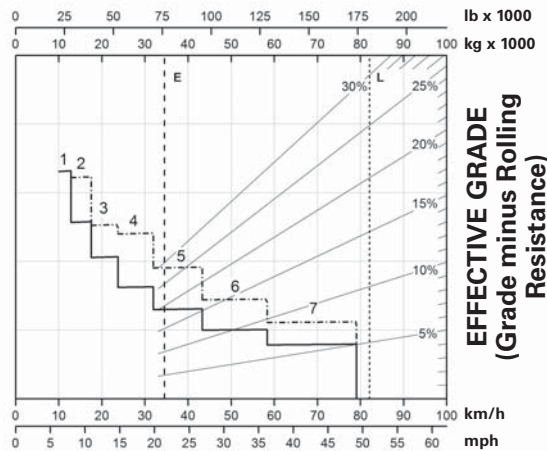

### SPEED

GRADE DISTANCE — 600 m (2000 ft)

### GROSS WEIGHT

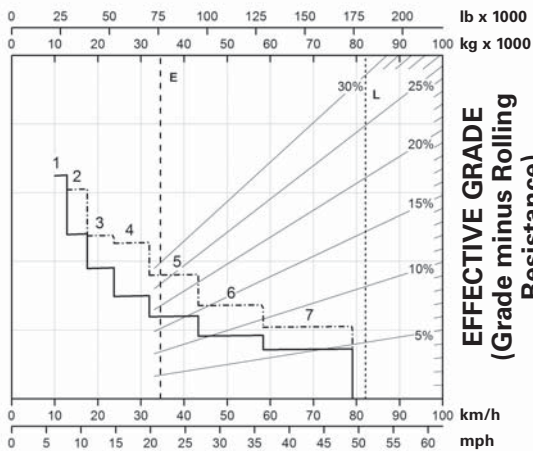

### SPEED

GRADE DISTANCE — 900 m (3000 ft)

### GROSS WEIGHT

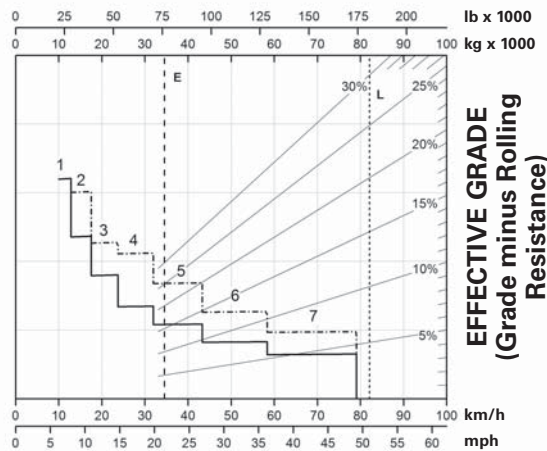

### SPEED

GRADE DISTANCE — 1500 m (5000 ft)

#### KEY

- 1 — 1st Gear
- 2 — 2nd Gear
- 3 — 3rd Gear
- 4 — 4th Gear
- 5 — 5th Gear
- 6 — 6th Gear
- 7 — 7th Gear

#### KEY

- E — Empty 34 893 kg (76,925 lb)
- L — Target GMW 82 100 kg (181,000 lb)
- With ARC Only
- - - - - ARC and Engine Brake

\*Meets Tier 4 Final, Stage IV, and Japan 2014 (Tier 4 Final) emission standards.

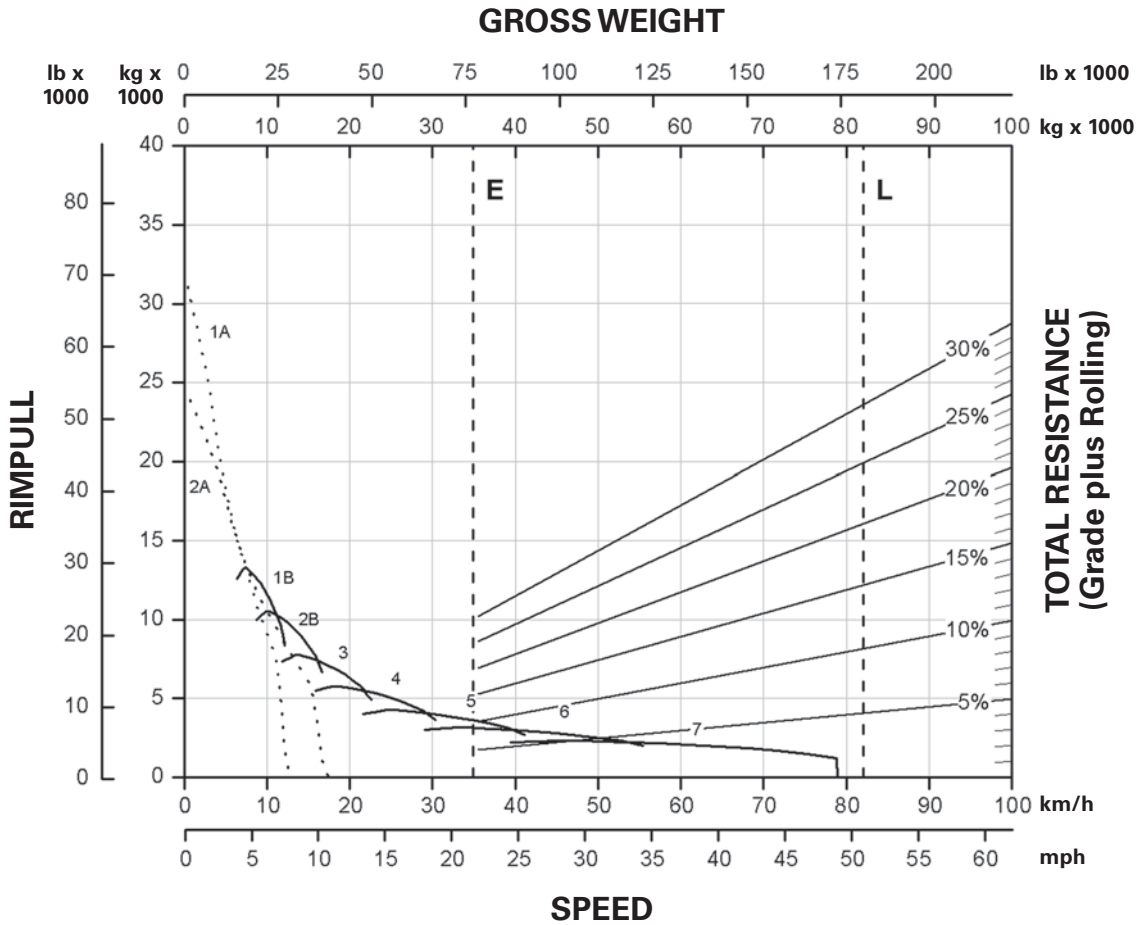

**KEY**

- 1A – 1st Gear (Torque Converter)
- 1B – 1st gear
- 2A – 2nd Gear (Torque Converter)
- 2B – 2nd Gear
- 3 – 3rd Gear
- 4 – 4th Gear
- 5 – 5th Gear
- 6 – 6th Gear
- 7 – 7th Gear

**KEY**

- E – Empty Weight 34 893 kg (76,925 lb)
- L – Target GMW 82 100 kg (181,000 lb)



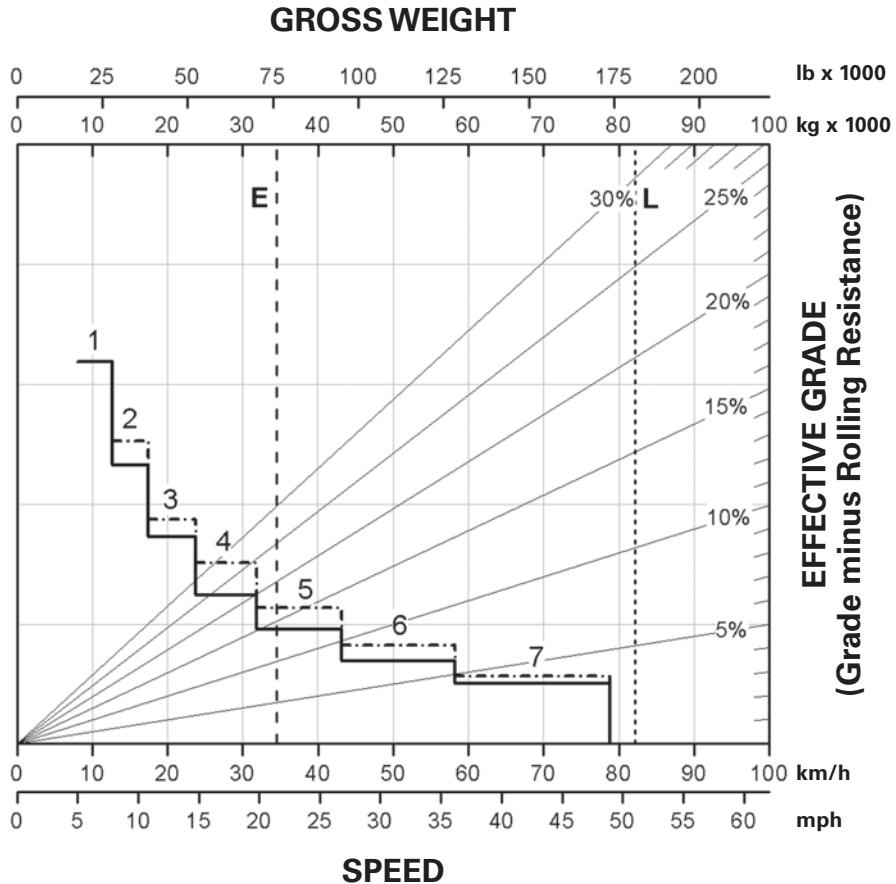

**KEY**

- 1 — 1st Gear
- 2 — 2nd Gear
- 3 — 3rd Gear
- 4 — 4th Gear
- 5 — 5th Gear
- 6 — 6th Gear
- 7 — 7th Gear

**KEY**

- E — Empty Weight 34 893 kg (76,925 lb)
- L — Target GMW 82 100 kg (181,000 lb)
- With ARC Only
- - - - - ARC and Engine Brake

772G Brake Performance

- 450 m (1500 ft)
- 600 m (2000 ft)
- 900 m (3000 ft)
- 1500 m (5000 ft)

GROSS WEIGHT

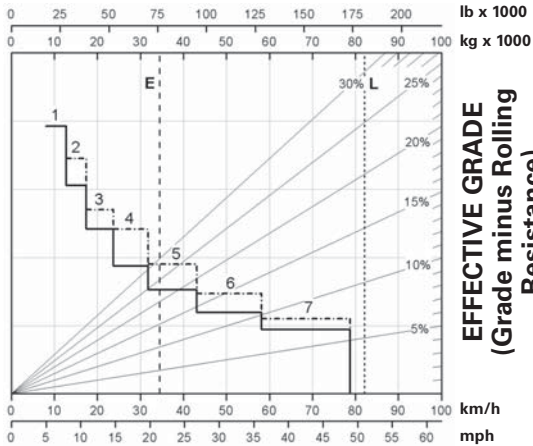

SPEED

GRADE DISTANCE — 450 m (1500 ft)

GROSS WEIGHT

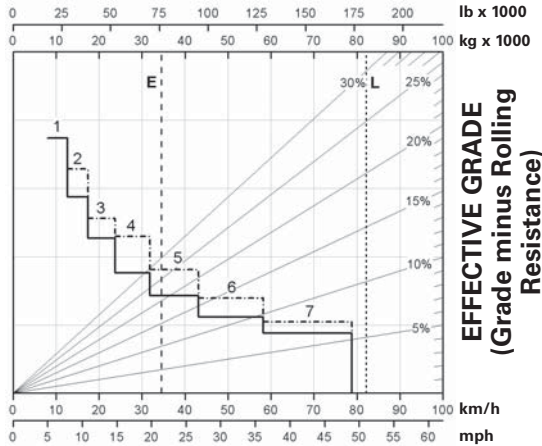

SPEED

GRADE DISTANCE — 600 m (2000 ft)

GROSS WEIGHT

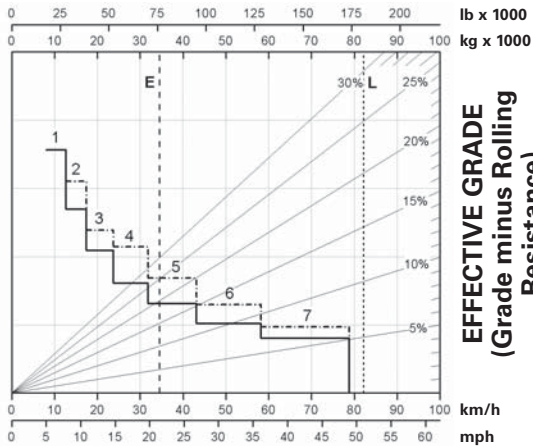

SPEED

GRADE DISTANCE — 900 m (3000 ft)

GROSS WEIGHT

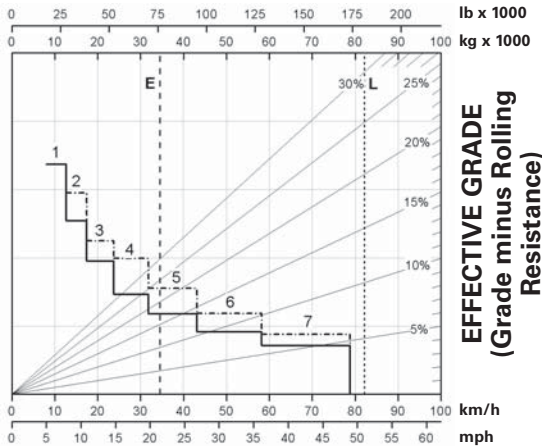

SPEED

GRADE DISTANCE — 1500 m (5000 ft)

KEY

- 1 – 1st Gear
- 2 – 2nd Gear
- 3 – 3rd Gear
- 4 – 4th Gear
- 5 – 5th Gear
- 6 – 6th Gear
- 7 – 7th Gear

KEY

- E – Empty Weight 34 893 kg (76,925 lb)
- L – Target GMW 82 100 kg (181,000 lb)
- With ARC Only
- - - - - ARC and Engine Brake

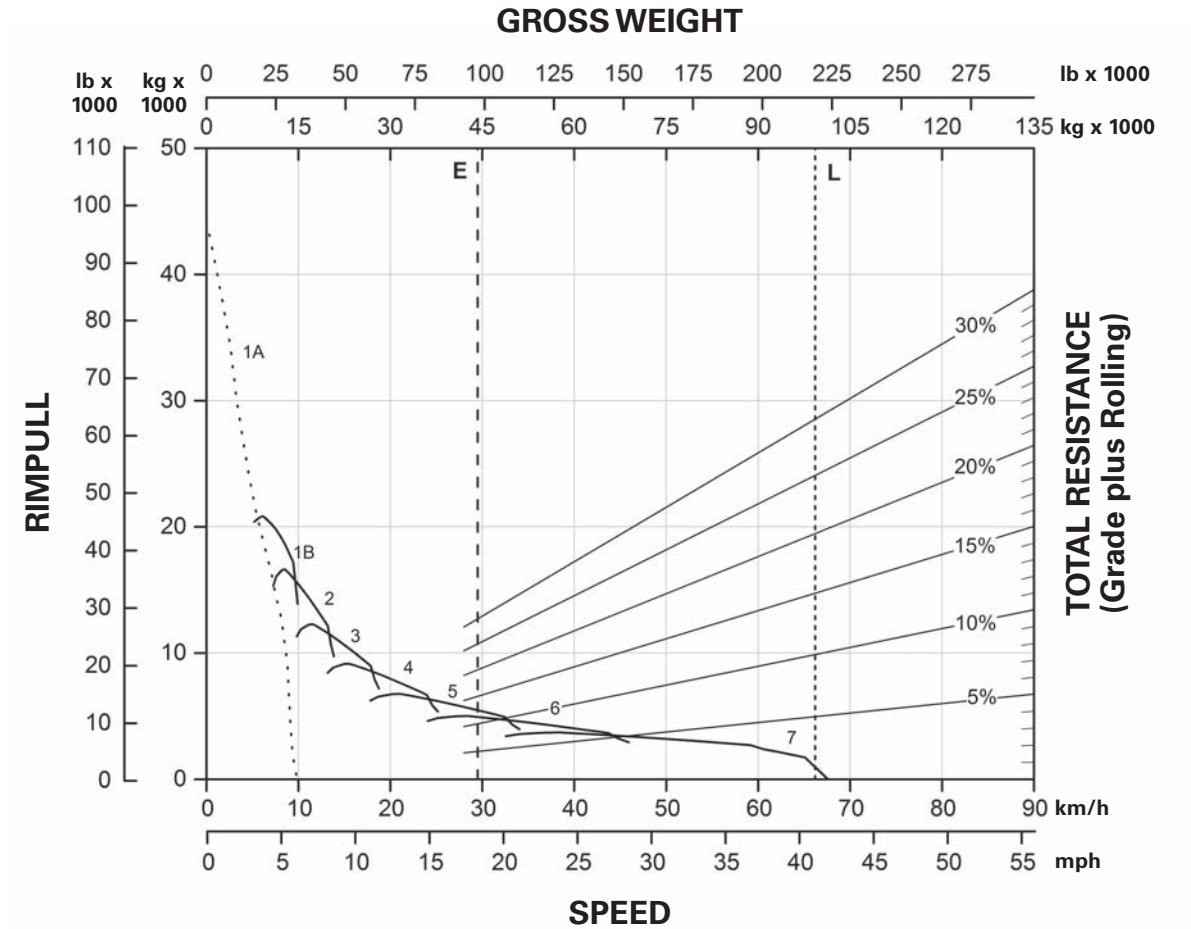

**KEY**

- 1A — 1st Gear (Torque Converter)
- 1B — 1st Gear
- 2 — 2nd Gear
- 3 — 3rd Gear
- 4 — 4th Gear
- 5 — 5th Gear
- 6 — 6th Gear
- 7 — 7th Gear

**KEY**

- E — Empty Weight 44 232 kg (97,515 lb)
- L — Target GMW 99 300 kg (218,919 lb)

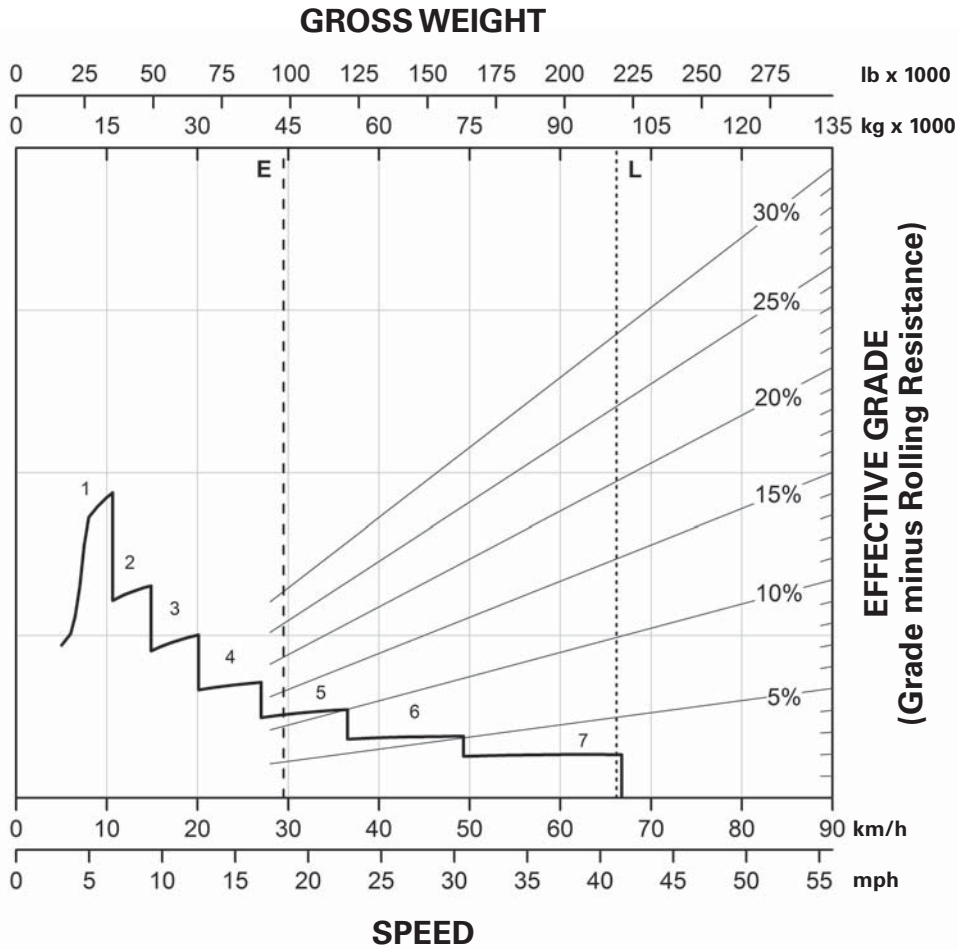

- KEY**
- 1 – 1st Gear
  - 2 – 2nd Gear
  - 3 – 3rd Gear
  - 4 – 4th Gear
  - 5 – 5th Gear
  - 6 – 6th Gear
  - 7 – 7th Gear

- KEY**
- E – Empty Weight 44 232 kg (97,515 lb)
  - L – Target GMW 99 300 kg (218,919 lb)

# Mining & Off-Highway Trucks

## 773E Brake Performance

- 450 m (1500 ft)    ● 600 m (2000 ft)
- 900 m (3000 ft)    ● 1500 m (5000 ft)

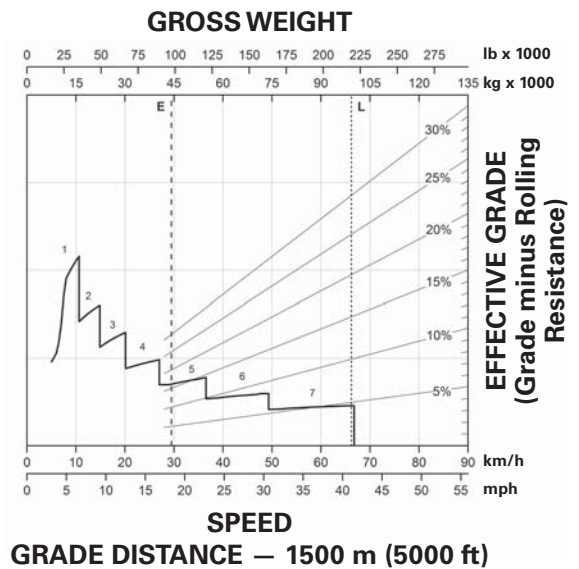
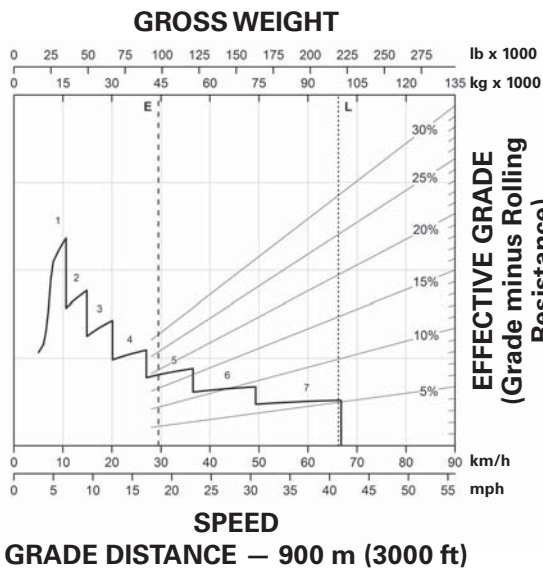
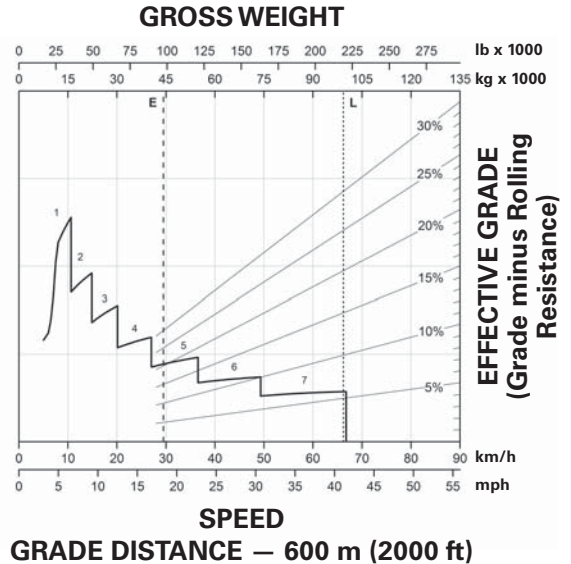
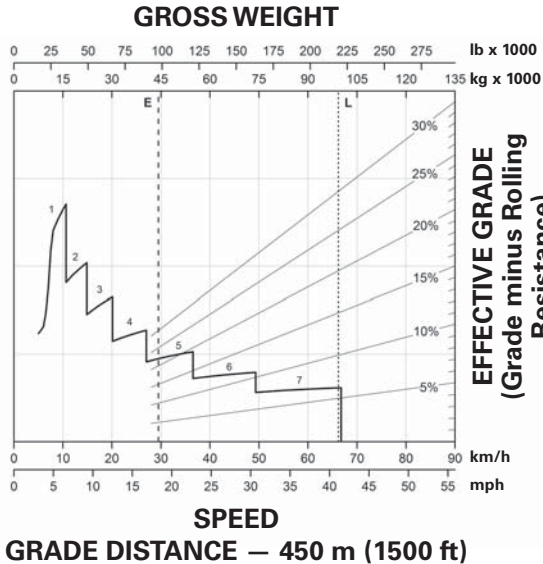

**KEY**

- 1 — 1st Gear
- 2 — 2nd Gear
- 3 — 3rd Gear
- 4 — 4th Gear
- 5 — 5th Gear
- 6 — 6th Gear
- 7 — 7th Gear

**KEY**

- E — Empty Weight 44 232 kg (97,515 lb)
- L — Target GMW 99 300 kg (218,919 lb)

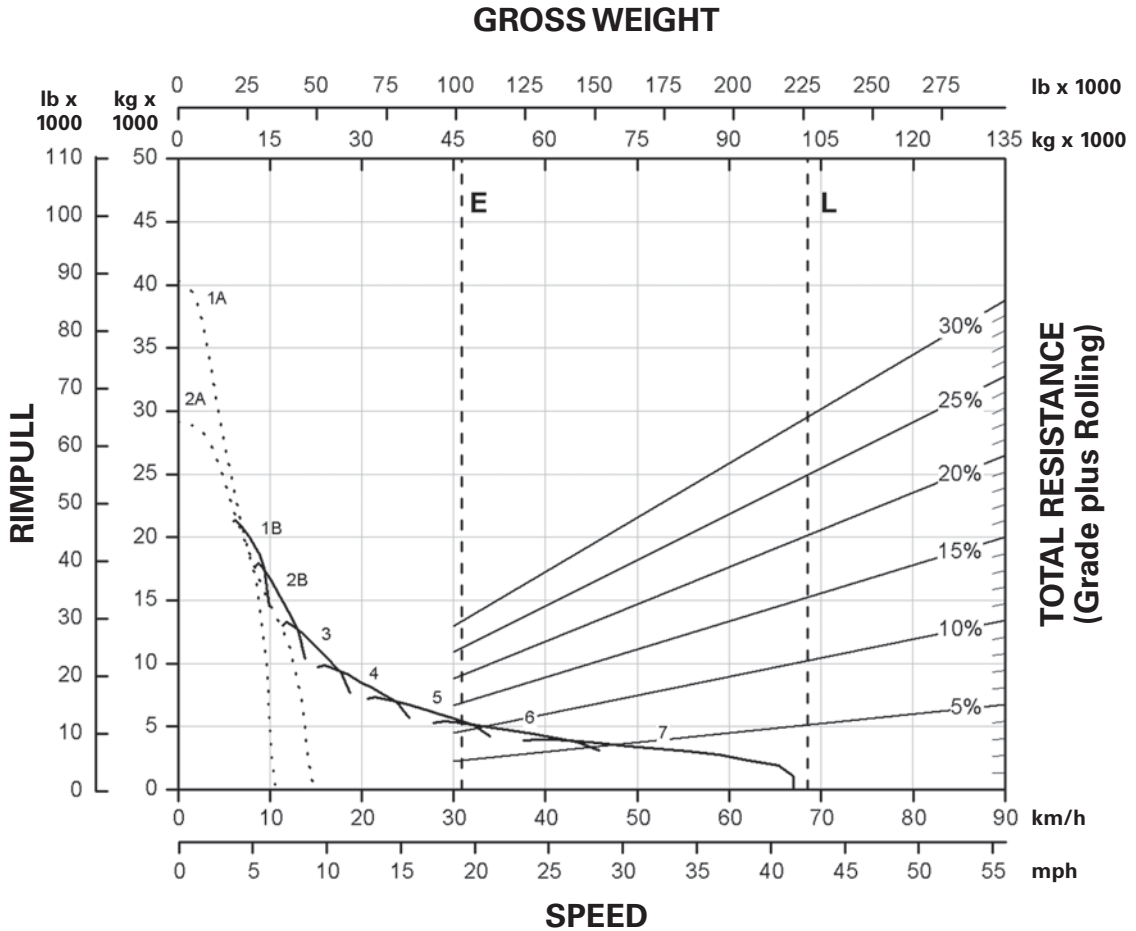

**KEY**

- 1A — 1st Gear (Torque Converter)
- 1B — 1st Gear
- 2A — 2nd Gear (Torque Converter)
- 2B — 2nd Gear
- 3 — 3rd Gear
- 4 — 4th Gear
- 5 — 5th Gear
- 6 — 6th Gear
- 7 — 7th Gear

**KEY**

- E — Empty 46 239 kg (101,726 lb)
- L — Target GMW 102 739 kg (226,500 lb)

\*Meets Tier 4 Final emission standards.

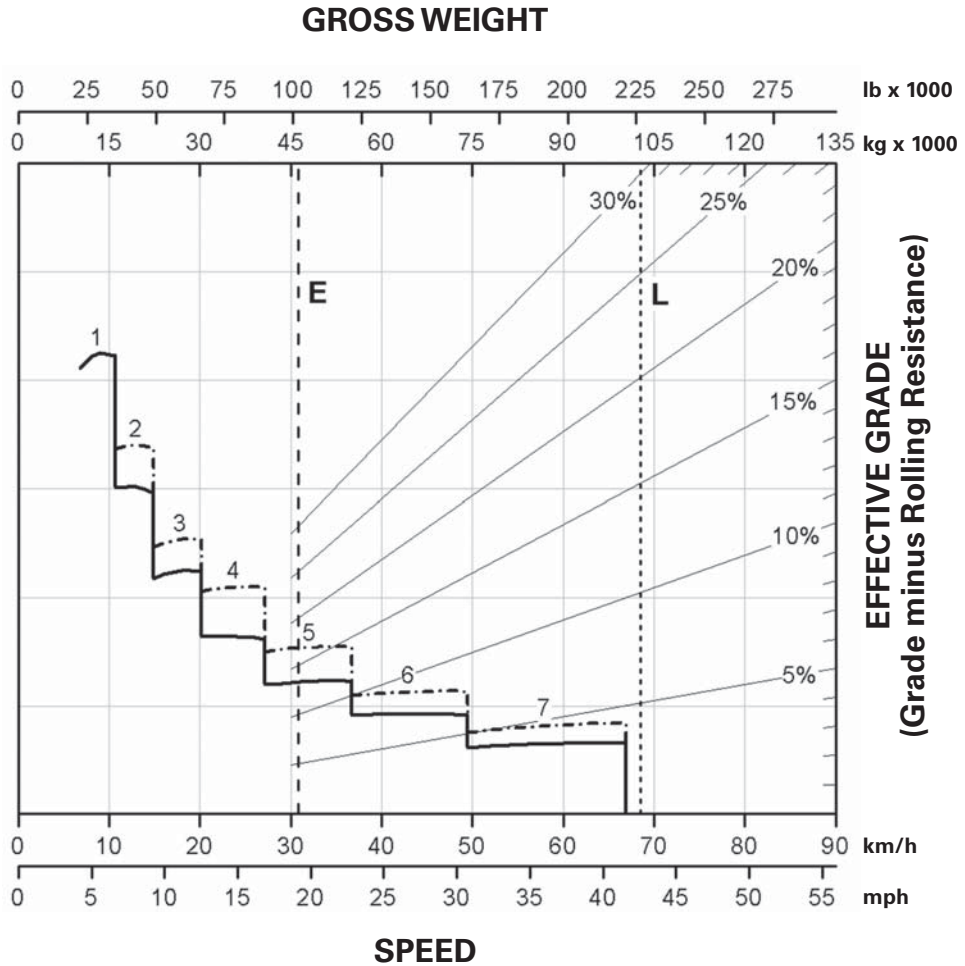

- KEY**
- 1 — 1st Gear
  - 2 — 2nd Gear
  - 3 — 3rd Gear
  - 4 — 4th Gear
  - 5 — 5th Gear
  - 6 — 6th Gear
  - 7 — 7th Gear

- KEY**
- E — Empty 46 239 kg (101,726 lb)
  - L — Target GMW 102 739 kg (226,500 lb)
  - With ARC Only
  - - - - - ARC and Engine Brake

\*Meets Tier 4 Final emission standards.

# 773G\* Brake Performance

- 450 m (1500 ft)
- 600 m (2000 ft)
- 900 m (3000 ft)
- 1500 m (5000 ft)

# Mining & Off-Highway Trucks

## GROSS WEIGHT

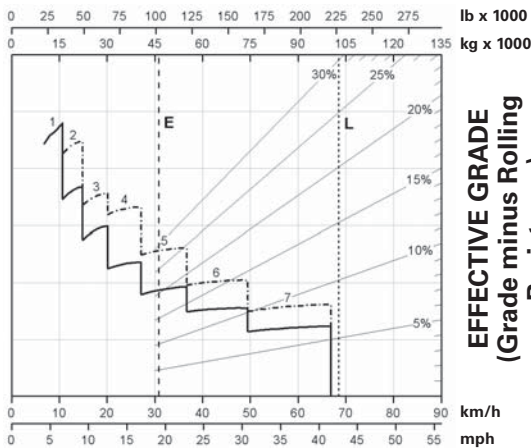

## SPEED

GRADE DISTANCE — 450 m (1500 ft)

## GROSS WEIGHT

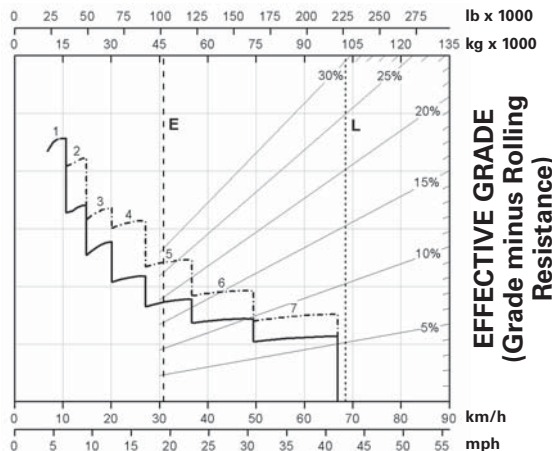

## SPEED

GRADE DISTANCE — 600 m (2000 ft)

## GROSS WEIGHT

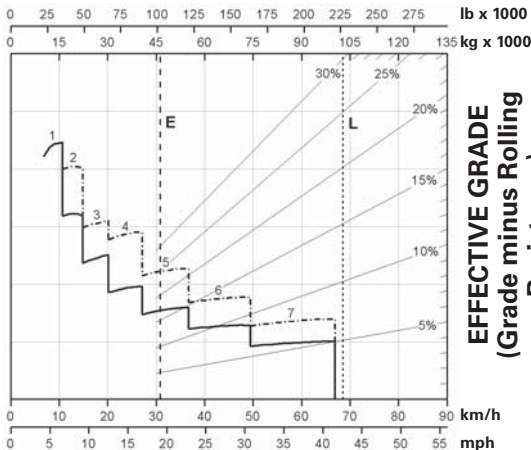

## SPEED

GRADE DISTANCE — 900 m (3000 ft)

## GROSS WEIGHT

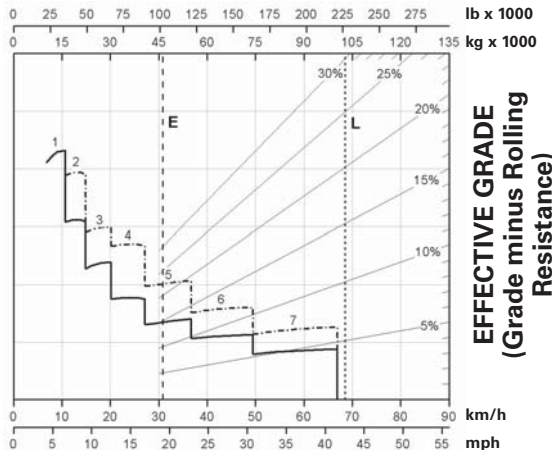

## SPEED

GRADE DISTANCE — 1500 m (5000 ft)

### KEY

- 1 — 1st Gear
- 2 — 2nd Gear
- 3 — 3rd Gear
- 4 — 4th Gear
- 5 — 5th Gear
- 6 — 6th Gear

### KEY

- E — Empty 46 239 kg (101,726 lb)
- L — Target GMW 102 739 kg (226,500 lb)
- With ARC Only
- - - - - ARC and Engine Brake

\*Meets Tier 4 Final emission standards.



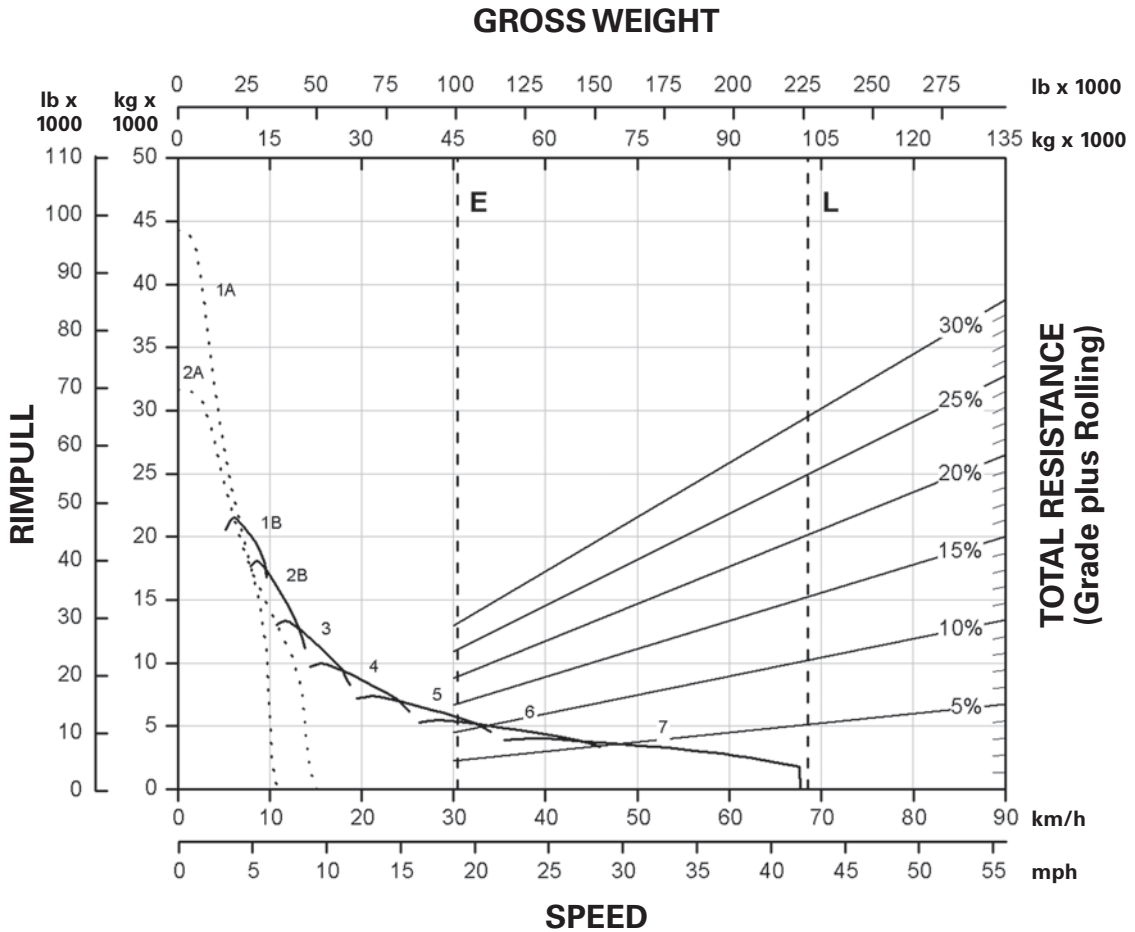

**KEY**

- 1A — 1st Gear (Torque Converter)
- 1B — 1st Gear
- 2A — 2nd Gear (Torque Converter)
- 2B — 2nd Gear
- 3 — 3rd Gear
- 4 — 4th Gear
- 5 — 5th Gear
- 6 — 6th Gear
- 7 — 7th Gear

**KEY**

- E — Empty 45 585 kg (100,286 lb)
- L — Target GMW 102 739 kg (226,500 lb)

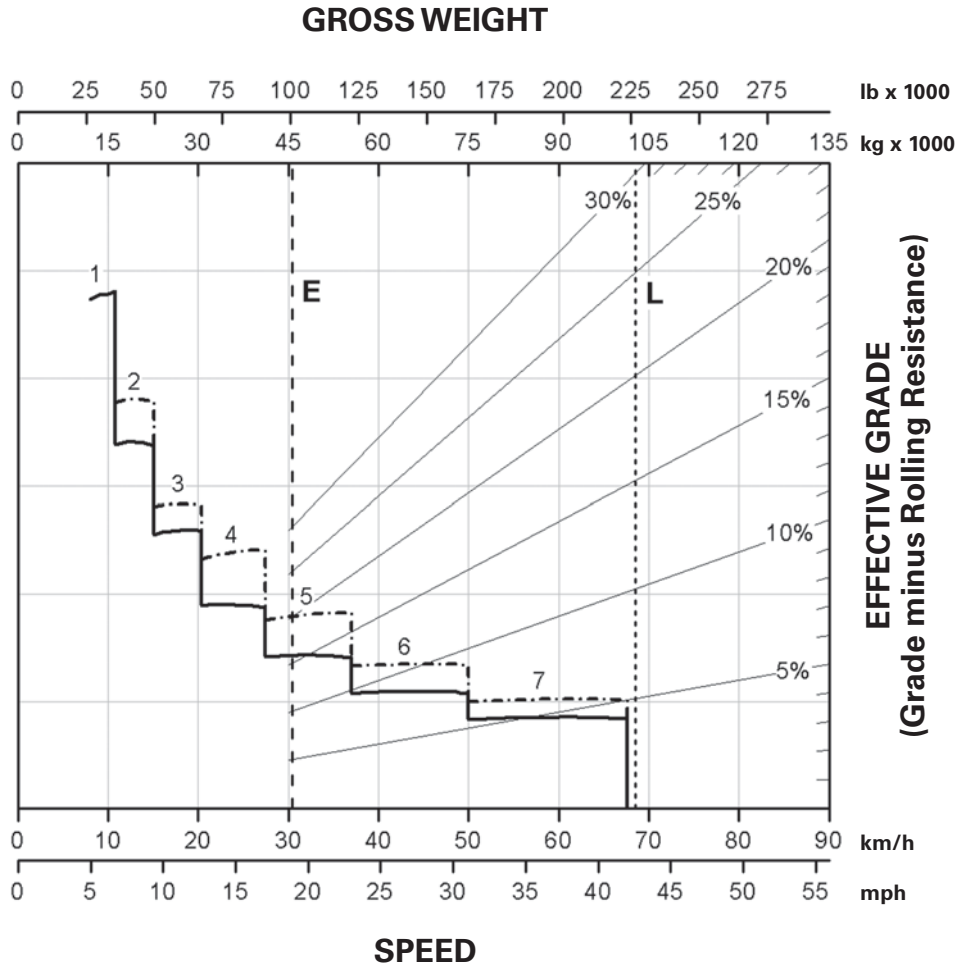

**CONTINUOUS GRADE LENGTH**

- KEY**
- 1 — 1st Gear
  - 2 — 2nd Gear
  - 3 — 3rd Gear
  - 4 — 4th Gear
  - 5 — 5th Gear
  - 6 — 6th Gear
  - 7 — 7th Gear

- KEY**
- E — Empty 45 585 kg (100,286 lb)
  - L — Target GMW 102 739 kg (226,500 lb)
  - With ARC Only
  - - - - - ARC and Engine Brake

# Mining & Off-Highway Trucks

## 773G Brake Performance

- 450 m (1500 ft)    ● 600 m (2000 ft)
- 900 m (3000 ft)    ● 1500 m (5000 ft)

### GROSS WEIGHT

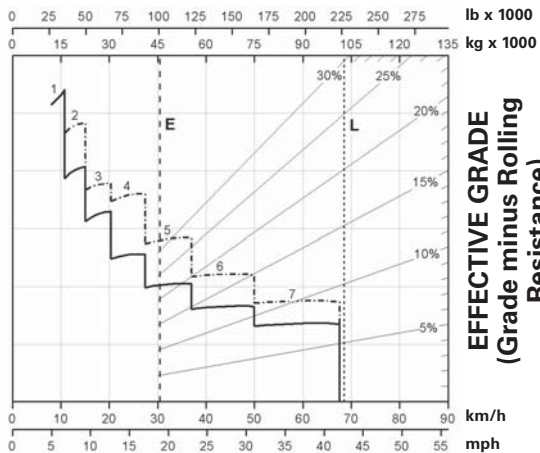

### SPEED

GRADE DISTANCE — 450 m (1500 ft)

### GROSS WEIGHT

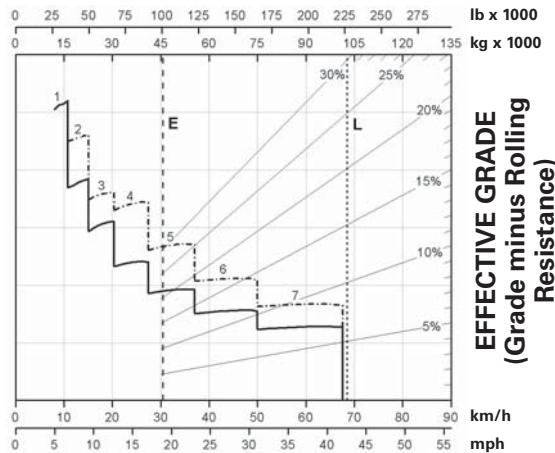

### SPEED

GRADE DISTANCE — 600 m (2000 ft)

### GROSS WEIGHT

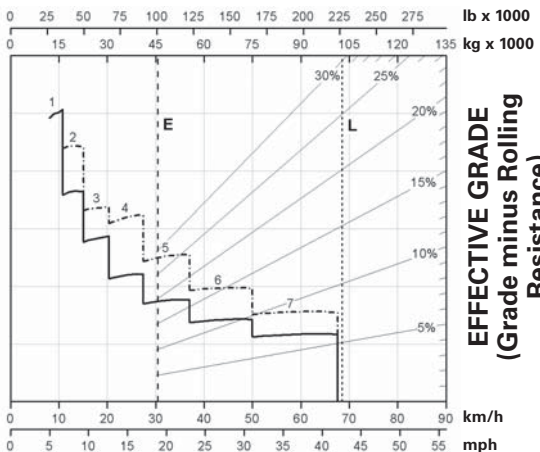

### SPEED

GRADE DISTANCE — 900 m (3000 ft)

### GROSS WEIGHT

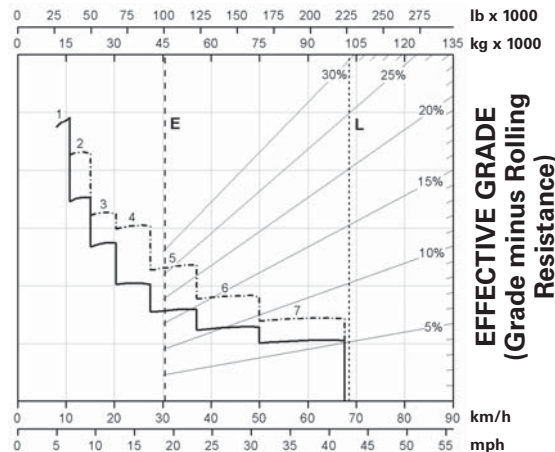

### SPEED

GRADE DISTANCE — 1500 m (5000 ft)

#### KEY

- 1 — 1st Gear
- 2 — 2nd Gear
- 3 — 3rd Gear
- 4 — 4th Gear
- 5 — 5th Gear
- 6 — 6th Gear
- 7 — 7th Gear

#### KEY

- E — Empty 45 585 kg (100,286 lb)
- L — Target GMW 102 739 kg (226,500 lb)
- With ARC Only
- - - - - ARC and Engine Brake

**GROSS WEIGHT**

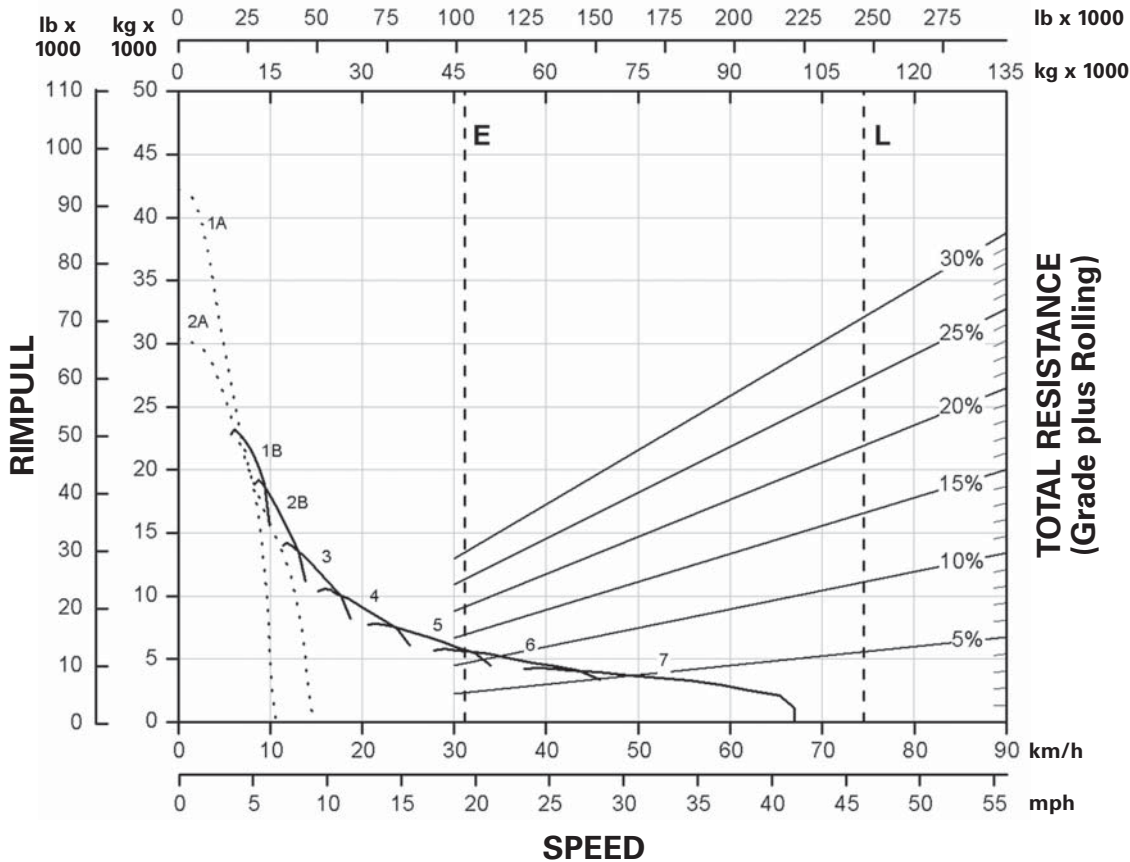

10

**KEY**

- 1A – 1st Gear (Torque Converter)
- 1B – 1st Gear
- 2A – 2nd Gear (Torque Converter)
- 2B – 2nd Gear
- 3 – 3rd Gear
- 4 – 4th Gear
- 5 – 5th Gear
- 6 – 6th Gear
- 7 – 7th Gear

**KEY**

- E – Empty 46 747 kg (102,842 lb)
- L – Target GMW 111 811 kg (246,500 lb)

\*Meets Tier 4 Final emission standards.

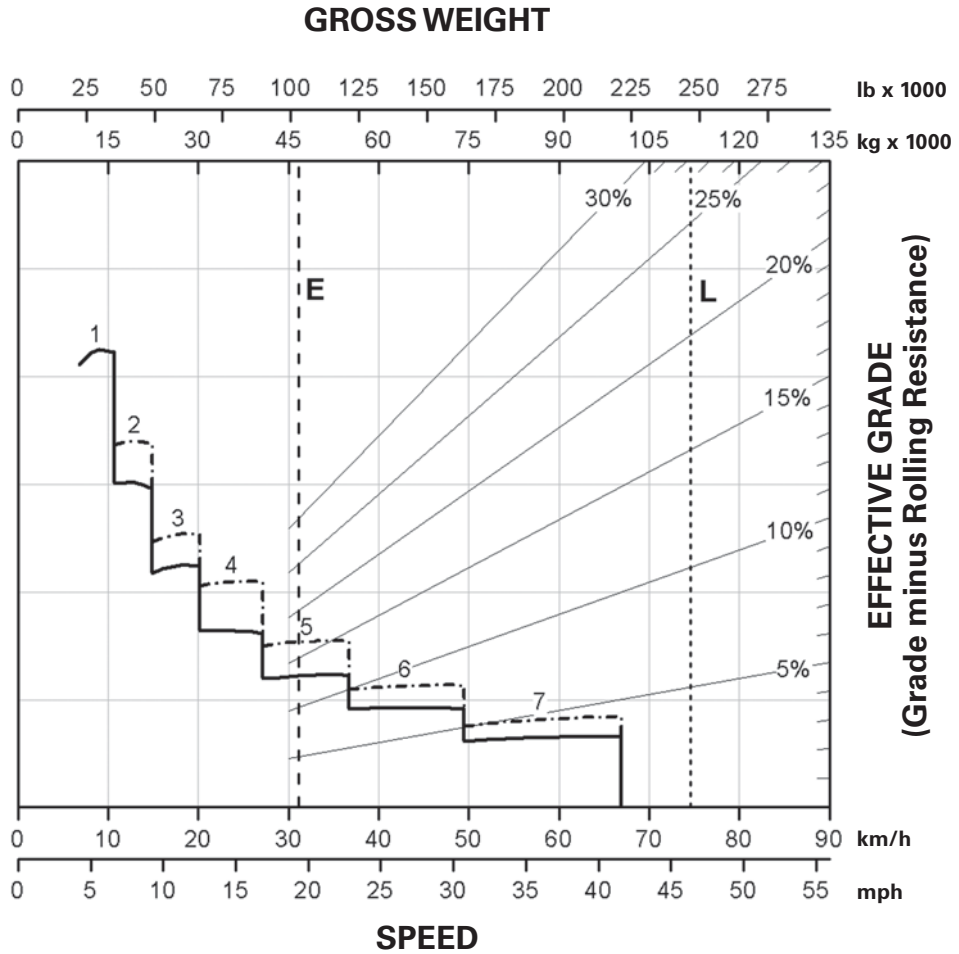

### CONTINUOUS GRADE LENGTH

**KEY**

- 1 — 1st Gear
- 2 — 2nd Gear
- 3 — 3rd Gear
- 4 — 4th Gear
- 5 — 5th Gear
- 6 — 6th Gear
- 7 — 7th Gear

**KEY**

- E — Empty 46 747 kg (102,842 lb)
- L — Target GMW 111 811 kg (246,500 lb)
- With ARC Only
- - - - - ARC and Engine Brake

\*Meets Tier 4 Final emission standards.

775G\* Brake Performance

- 450 m (1500 ft)
- 600 m (2000 ft)
- 900 m (3000 ft)
- 1500 m (5000 ft)

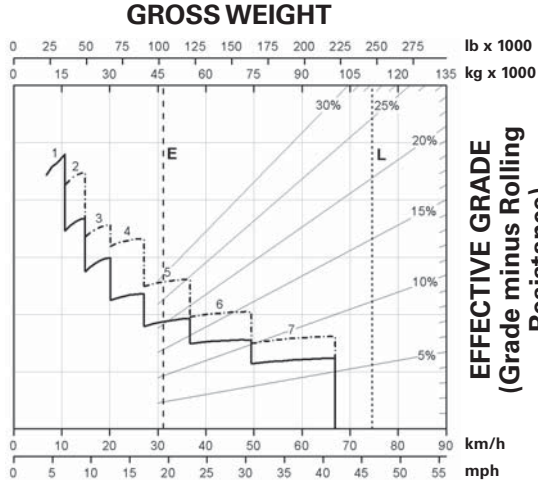

**SPEED**  
GRADE DISTANCE — 450 m (1500 ft)

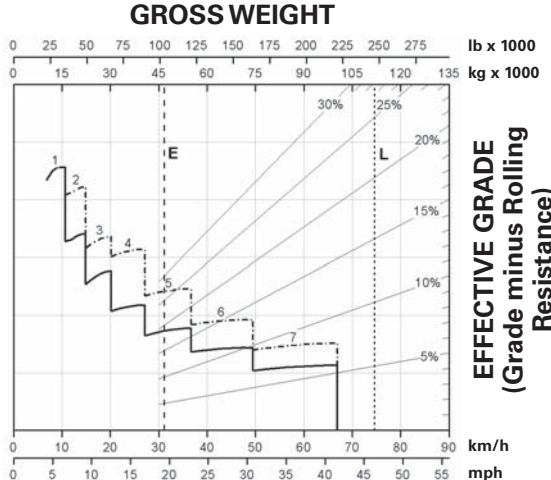

**SPEED**  
GRADE DISTANCE — 600 m (2000 ft)

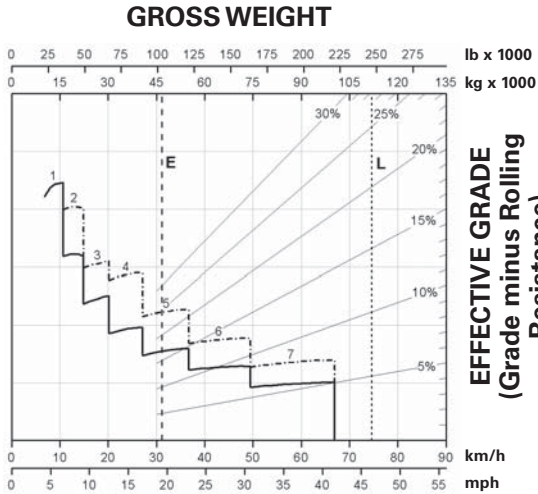

**SPEED**  
GRADE DISTANCE — 900 m (3000 ft)

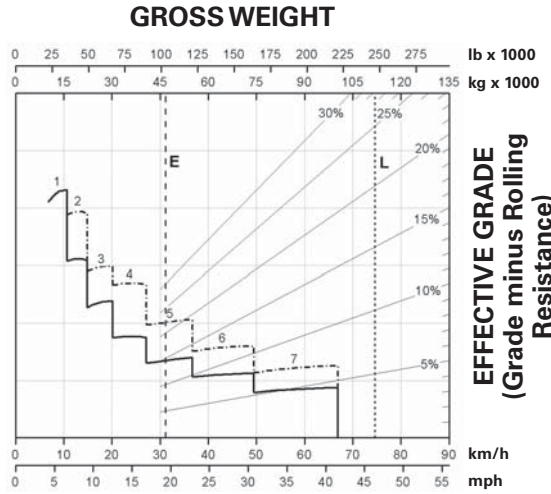

**SPEED**  
GRADE DISTANCE — 1500 m (5000 ft)

- KEY**
- 1 — 1st Gear
  - 2 — 2nd Gear
  - 3 — 3rd Gear
  - 4 — 4th Gear
  - 5 — 5th Gear
  - 6 — 6th Gear
  - 7 — 7th Gear

- KEY**
- E — Empty 46 747 kg (102,842 lb)
  - L — Target GMW 111 811 kg (246,500 lb)
  - With ARC Only
  - - - - - ARC and Engine Brake

\*Meets Tier 4 Final emission standards.

**GROSS WEIGHT**

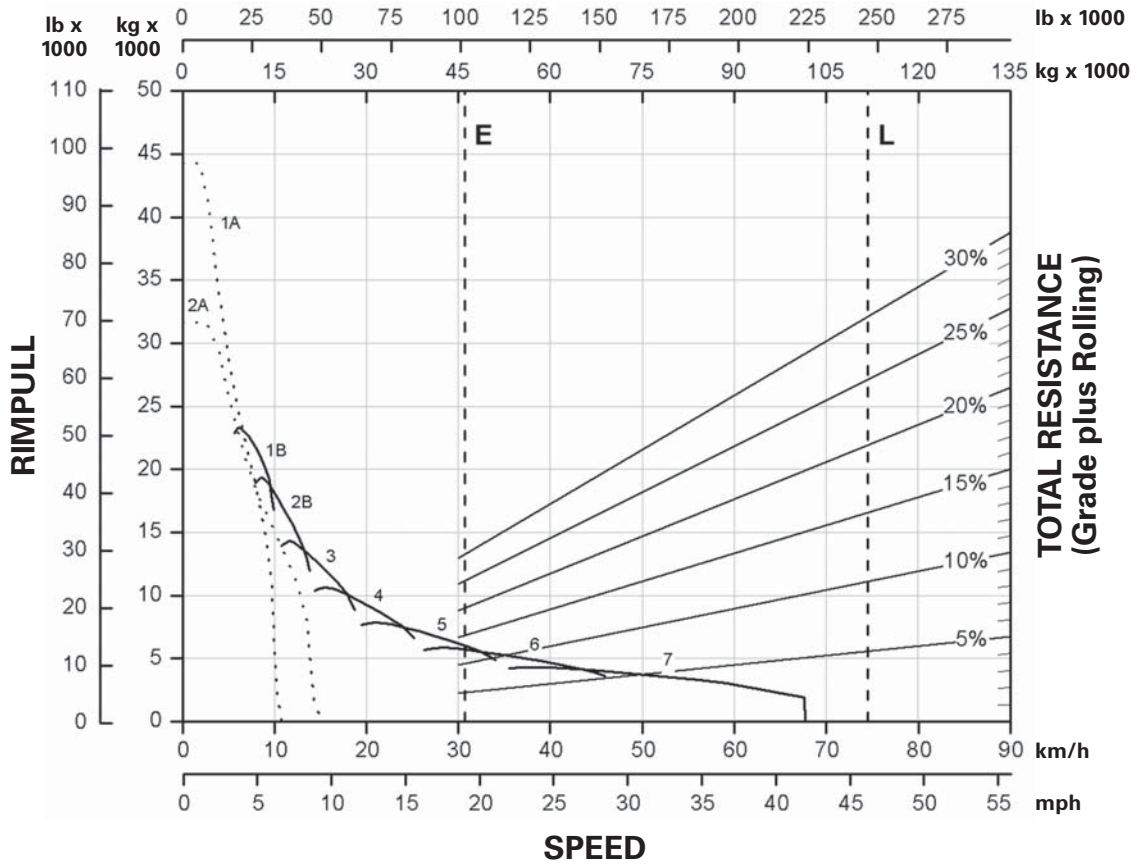

**KEY**

- 1A — 1st Gear (Torque Converter)
- 1B — 1st Gear
- 2A — 2nd Gear (Torque Converter)
- 2B — 2nd Gear
- 3 — 3rd Gear
- 4 — 4th Gear
- 5 — 5th Gear
- 6 — 6th Gear
- 7 — 7th Gear

**KEY**

- E — Empty 46 087 kg (101,392 lb)
- L — Target GMW 111 811 kg (246,500 lb)

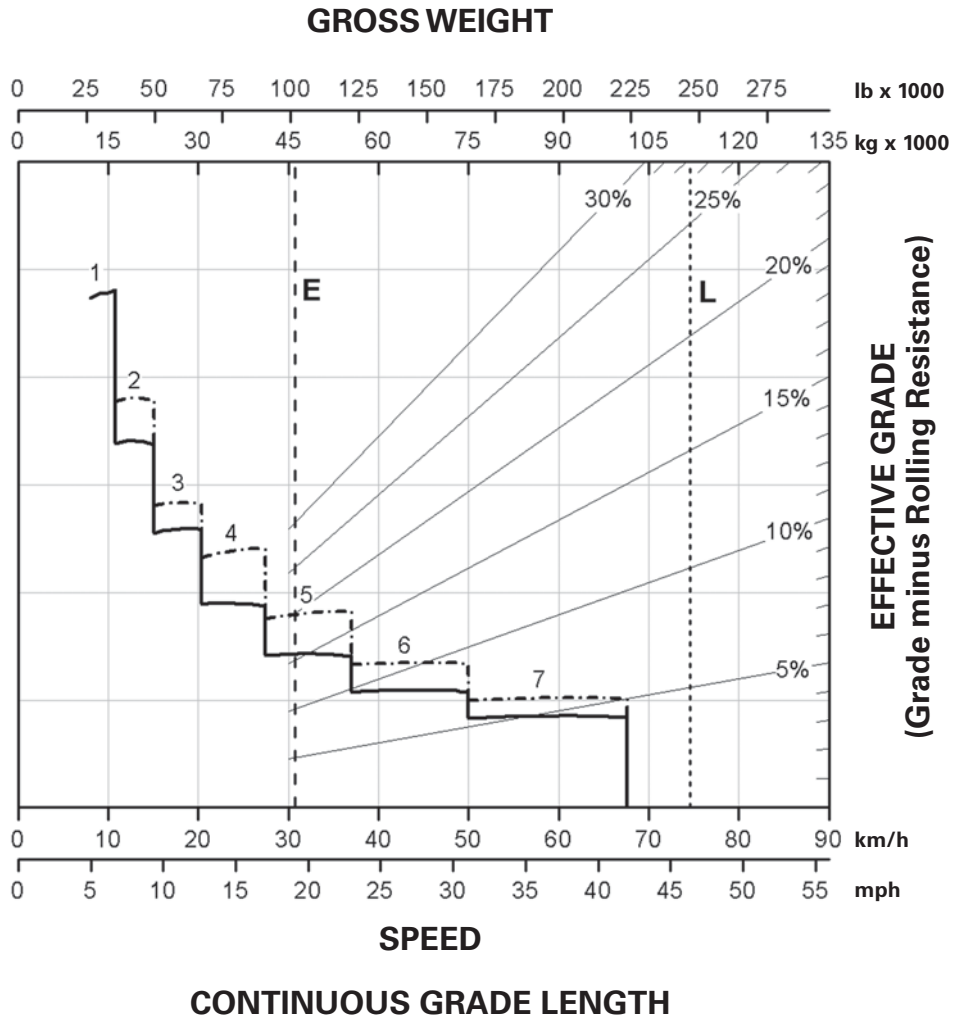

- KEY**
- 1 — 1st Gear
  - 2 — 2nd Gear
  - 3 — 3rd Gear
  - 4 — 4th Gear
  - 5 — 5th Gear
  - 6 — 6th Gear
  - 7 — 7th Gear

- KEY**
- E — Empty 46 087 kg (101,392 lb)
  - L — Target GMW 111 811 kg (246,500 lb)
  - With ARC Only
  - - - - - ARC and Engine Brake



# Mining & Off-Highway Trucks

## 775G Brake Performance

- 450 m (1500 ft)
- 600 m (2000 ft)
- 900 m (3000 ft)
- 1500 m (5000 ft)

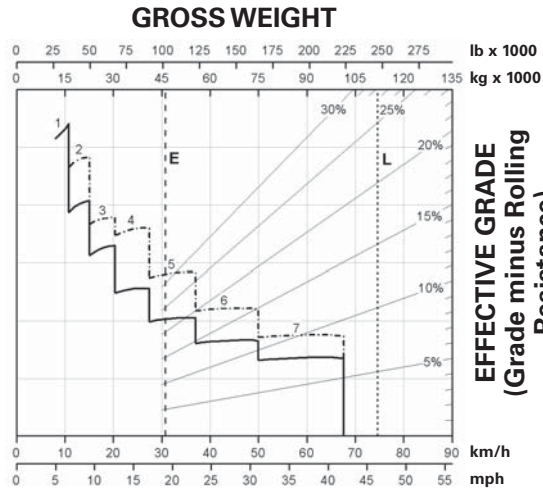

**GROSS WEIGHT**  
**EFFECTIVE GRADE (Grade minus Rolling Resistance)**  
**SPEED**  
**GRADE DISTANCE — 450 m (1500 ft)**

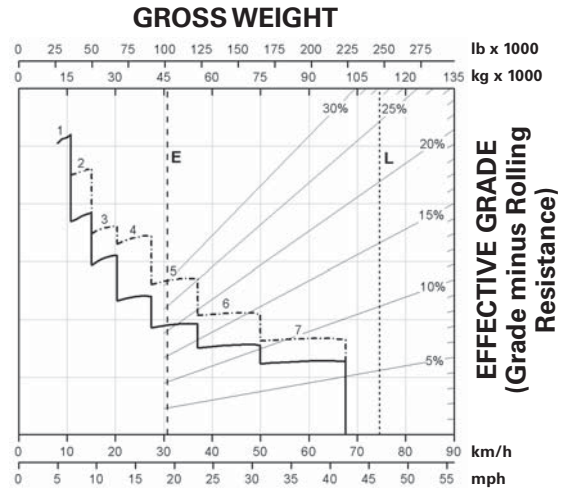

**GROSS WEIGHT**  
**EFFECTIVE GRADE (Grade minus Rolling Resistance)**  
**SPEED**  
**GRADE DISTANCE — 600 m (2000 ft)**

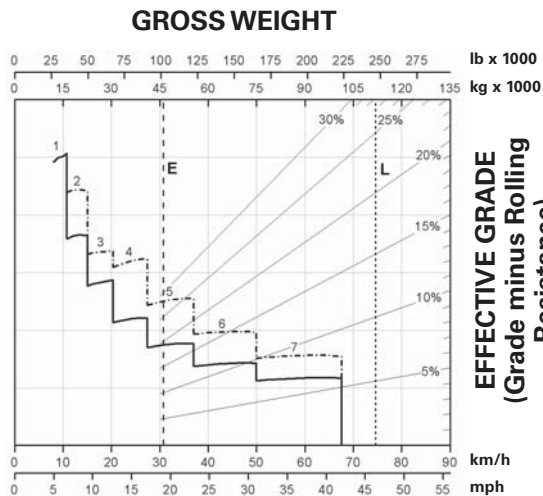

**GROSS WEIGHT**  
**EFFECTIVE GRADE (Grade minus Rolling Resistance)**  
**SPEED**  
**GRADE DISTANCE — 900 m (3000 ft)**

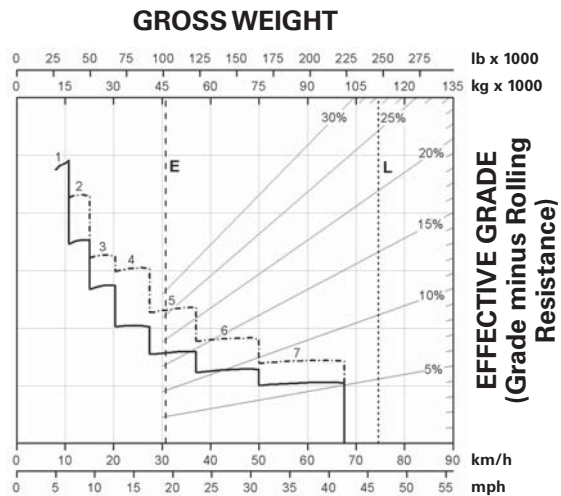

**GROSS WEIGHT**  
**EFFECTIVE GRADE (Grade minus Rolling Resistance)**  
**SPEED**  
**GRADE DISTANCE — 1500 m (5000 ft)**

### KEY

- 1 — 1st Gear
- 2 — 2nd Gear
- 3 — 3rd Gear
- 4 — 4th Gear
- 5 — 5th Gear
- 6 — 6th Gear
- 7 — 7th Gear

### KEY

- E — Empty 46 087 kg (101,392 lb)
- L — Target GMW 111 811 kg (246,500 lb)
- With ARC Only
- - - - - ARC and Engine Brake

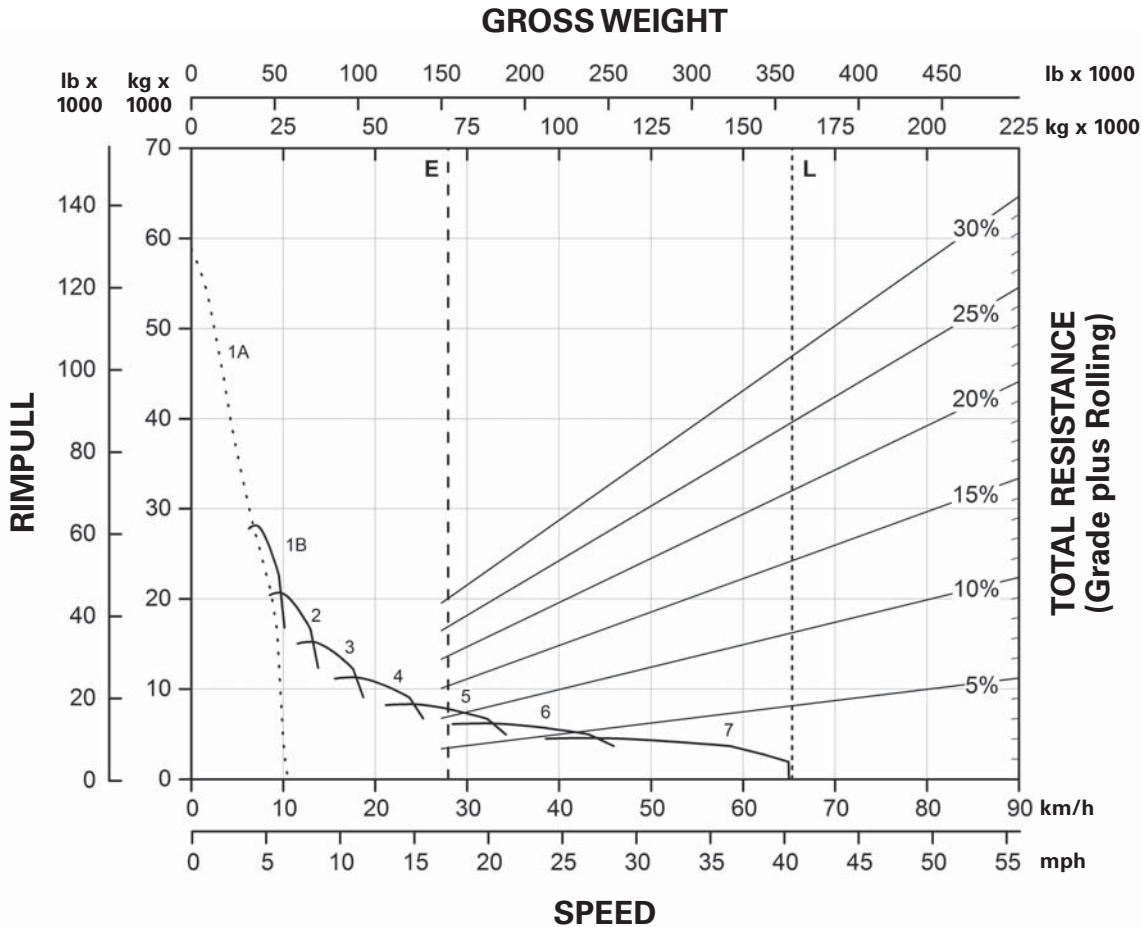

KEY

- 1A — 1st Gear (Torque Converter)
- 1B — 1st Gear
- 2 — 2nd Gear
- 3 — 3rd Gear
- 4 — 4th Gear
- 5 — 5th Gear
- 6 — 6th Gear
- 7 — 7th Gear

KEY

- E — Empty 70 753 kg (155,984 lb)
- L — Max GMW 163 360 kg (360,147 lb)

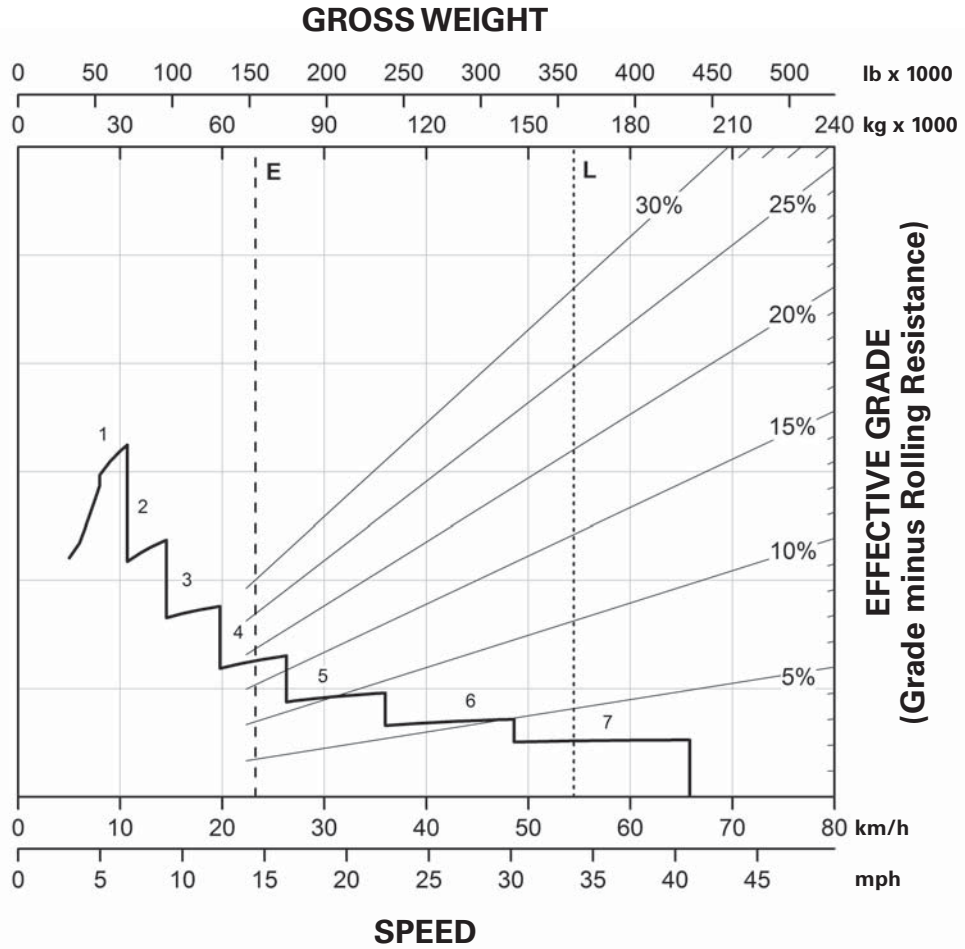

**CONTINUOUS GRADE LENGTH**

**KEY**

- 1 — 1st Gear
- 2 — 2nd Gear
- 3 — 3rd Gear
- 4 — 4th Gear
- 5 — 5th Gear
- 6 — 6th Gear
- 7 — 7th Gear

**KEY**

- E — Empty 70 753 kg (155,984 lb)
- L — Max GMW 163 360 kg (360,147 lb)

777E Brake Performance

- 450 m (1500 ft)
- 600 m (2000 ft)
- 900 m (3000 ft)
- 1500 m (5000 ft)

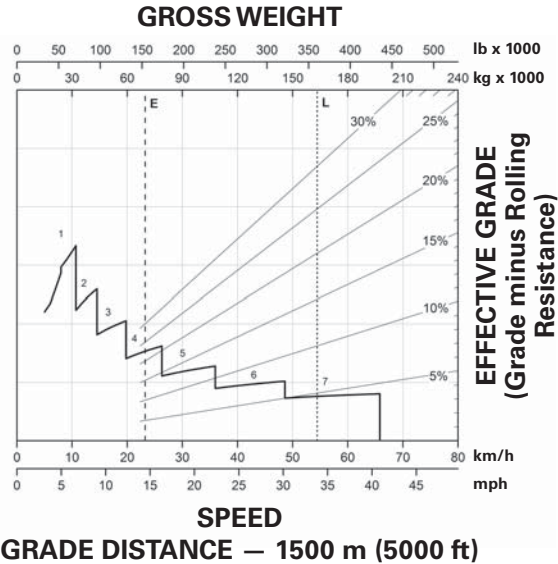
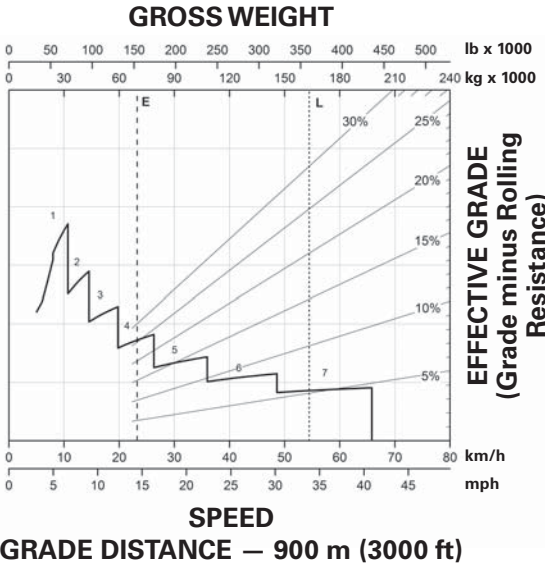
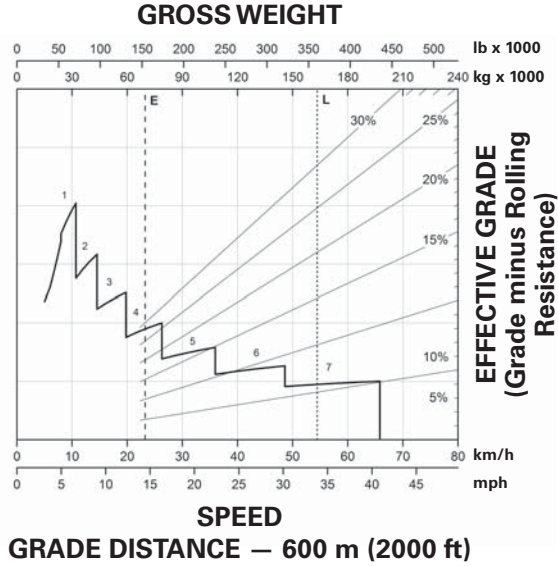
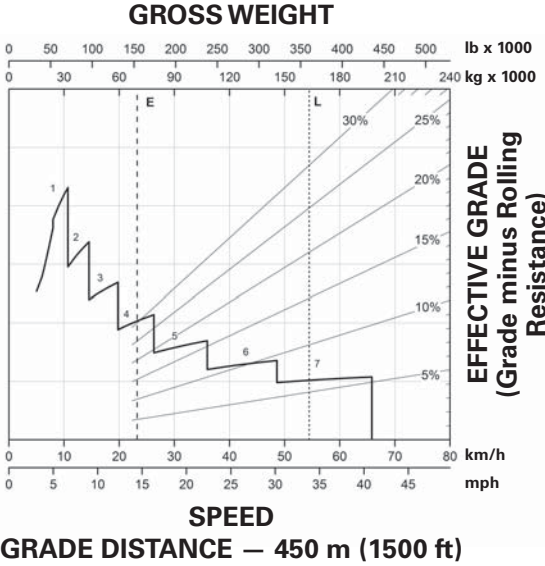

- KEY**
- 1 — 1st Gear
  - 2 — 2nd Gear
  - 3 — 3rd Gear
  - 4 — 4th Gear
  - 5 — 5th Gear
  - 6 — 6th Gear
  - 7 — 7th Gear

- KEY**
- E — Empty 70 753 kg (155,984 lb)
  - L — Max GMW 163 360 kg (360,147 lb)

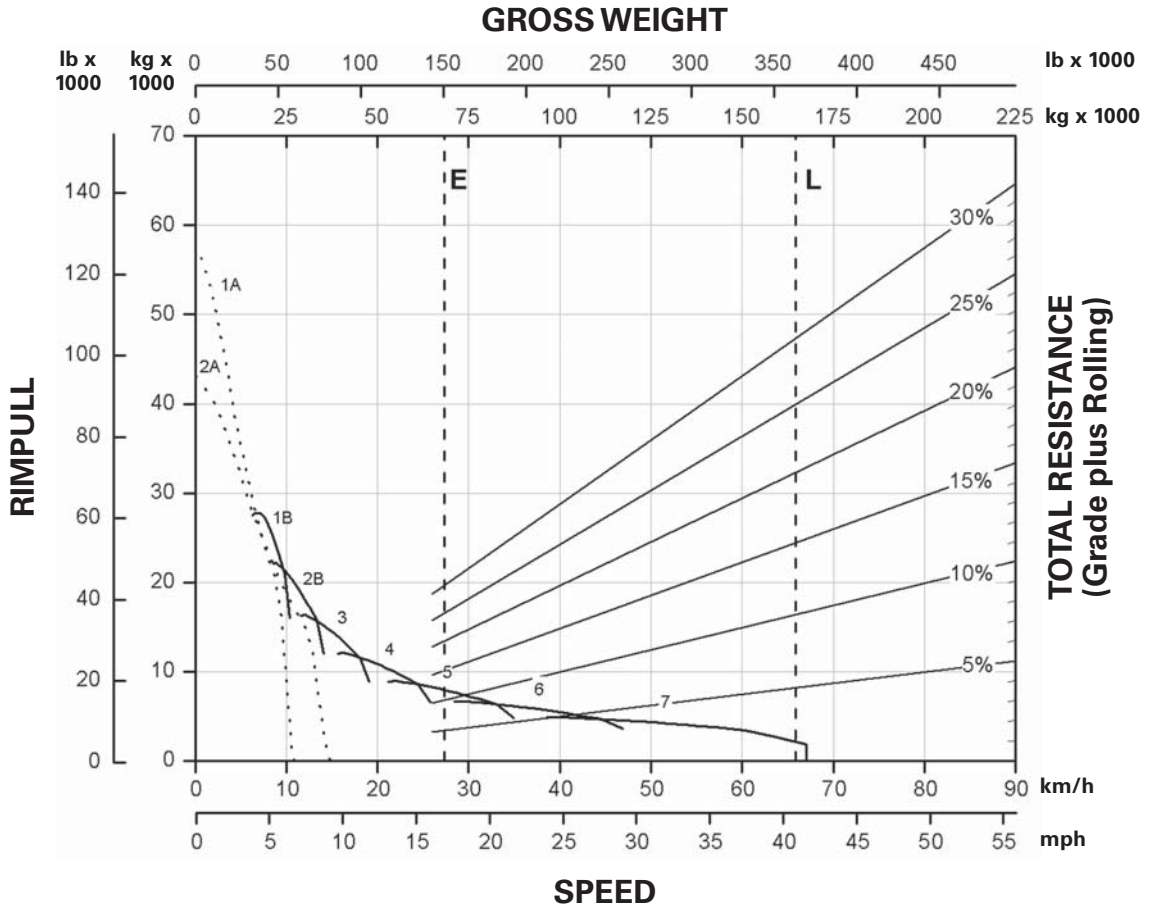

**KEY**

- 1A — 1st Gear (Torque Converter)
- 1B — 1st Gear
- 2A — 2nd Gear (Torque Converter)
- 2B — 2nd Gear
- 3 — 3rd Gear
- 4 — 4th Gear
- 5 — 5th Gear
- 6 — 6th Gear
- 7 — 7th Gear

**KEY**

- E — Empty 68 315 kg (150,609 lb)
- L — Target GMW 164 654 kg (363,000 lb)

\*Meets Tier 4 Final emission standards.

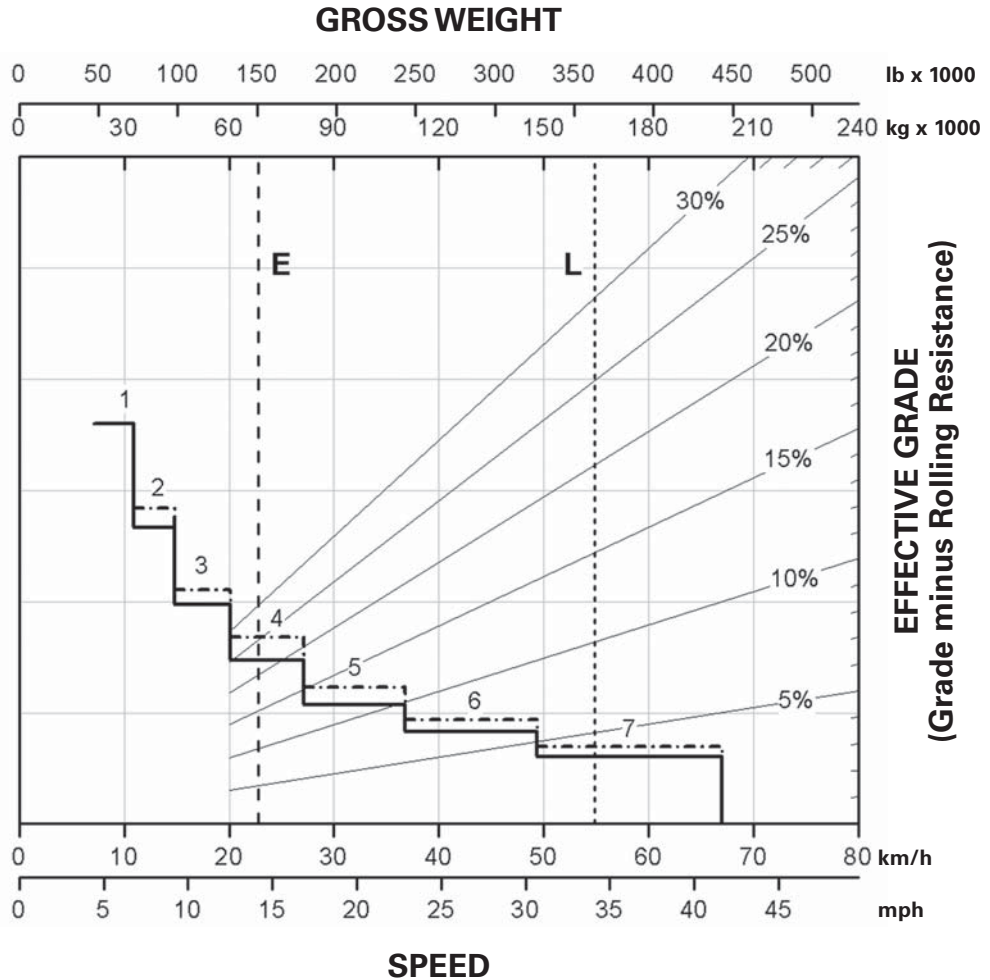

KEY

- 1 — 1st Gear
- 2 — 2nd Gear
- 3 — 3rd Gear
- 4 — 4th Gear
- 5 — 5th Gear
- 6 — 6th Gear
- 7 — 7th Gear

KEY

- E — Empty 68 315 kg (150,609 lb)
- L — Target GMW 164 654 kg (363,000 lb)
- With ARC Only
- - - - - ARC and Engine Brake

\*Meets Tier 4 Final emission standards.

# Mining & Off-Highway Trucks

## 777G\* Brake Performance

- 450 m (1500 ft)
- 600 m (2000 ft)
- 900 m (3000 ft)
- 1500 m (5000 ft)

### GROSS WEIGHT

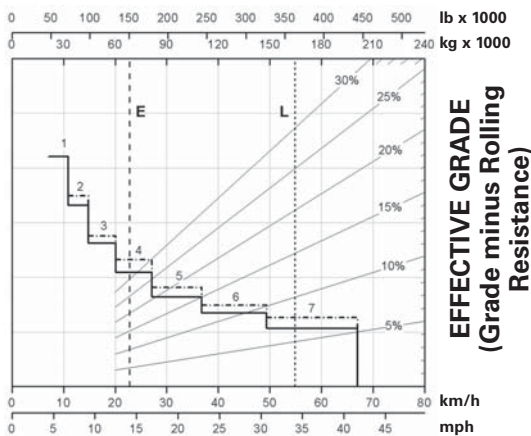

### SPEED

GRADE DISTANCE — 450 m (1500 ft)

### GROSS WEIGHT

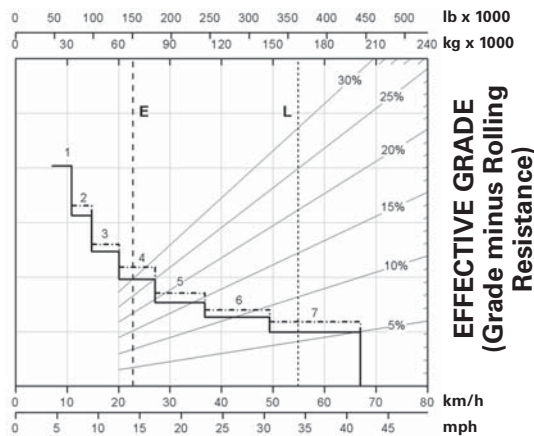

### SPEED

GRADE DISTANCE — 600 m (2000 ft)

### GROSS WEIGHT

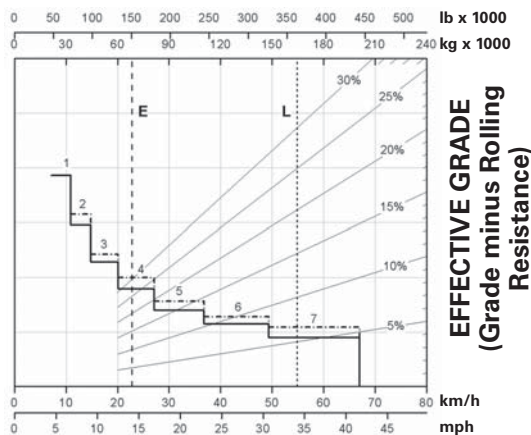

### SPEED

GRADE DISTANCE — 900 m (3000 ft)

### GROSS WEIGHT

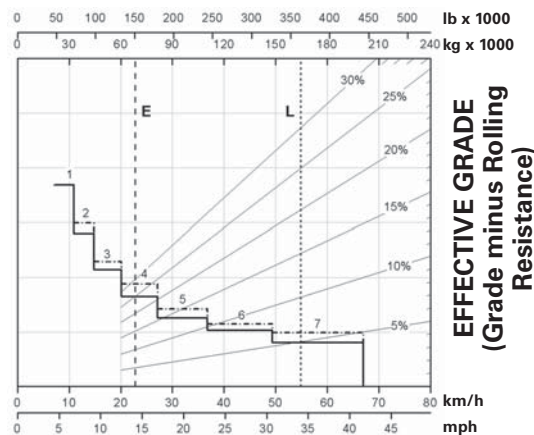

### SPEED

GRADE DISTANCE — 1500 m (5000 ft)

#### KEY

- 1 — 1st Gear
- 2 — 2nd Gear
- 3 — 3rd Gear
- 4 — 4th Gear
- 5 — 5th Gear
- 6 — 6th Gear
- 7 — 7th Gear

#### KEY

- E — Empty 68 315 kg (150,609 lb)
- L — Target GMW 164 654 kg (363,000 lb)
- With ARC Only
- - - - - ARC and Engine Brake

\*Meets Tier 4 Final emission standards.

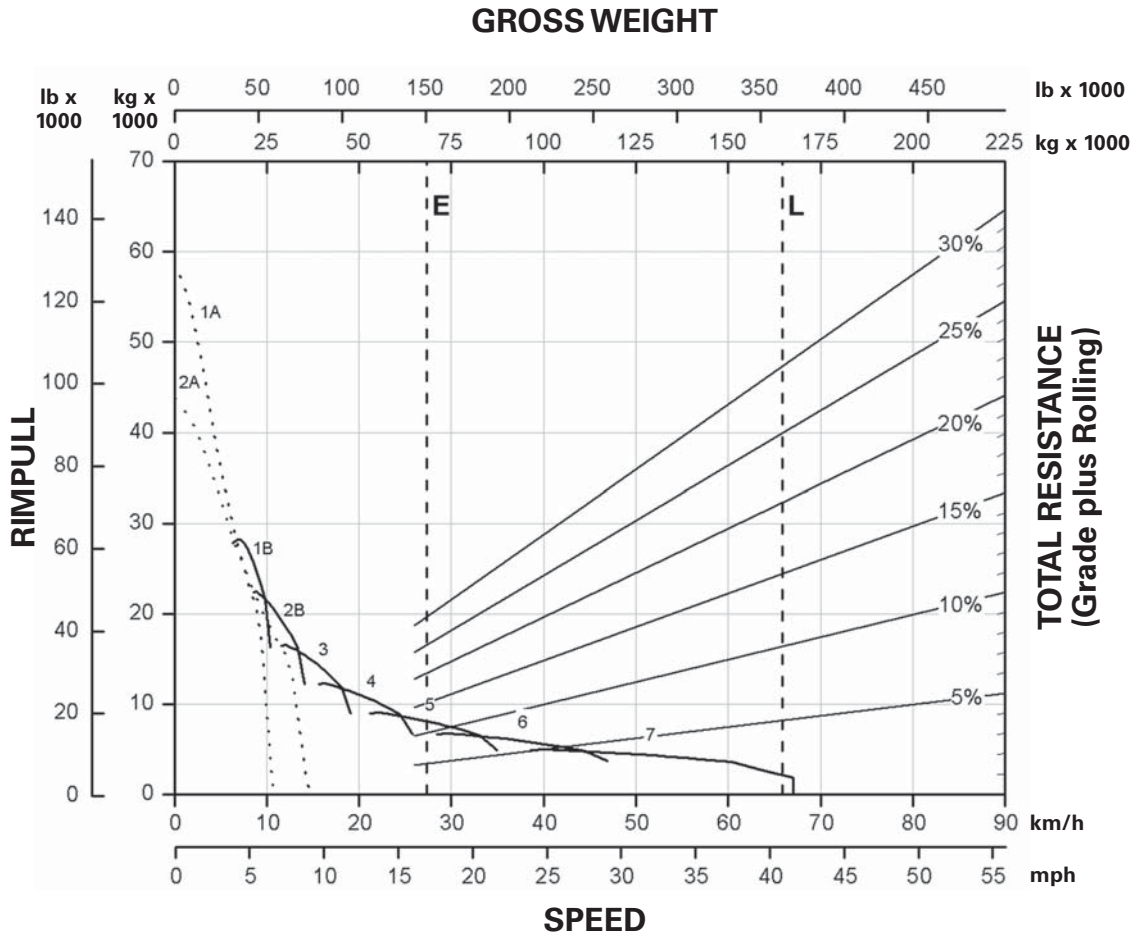

**KEY**

- 1A — 1st Gear (Torque Converter)
- 1B — 1st Gear
- 2A — 2nd Gear (Torque Converter)
- 2B — 2nd Gear
- 3 — 3rd Gear
- 4 — 4th Gear
- 5 — 5th Gear
- 6 — 6th Gear
- 7 — 7th Gear

**KEY**

- E — Empty 67 923 kg (149,744 lb)
- L — Target GMW 164 654 kg (363,000 lb)



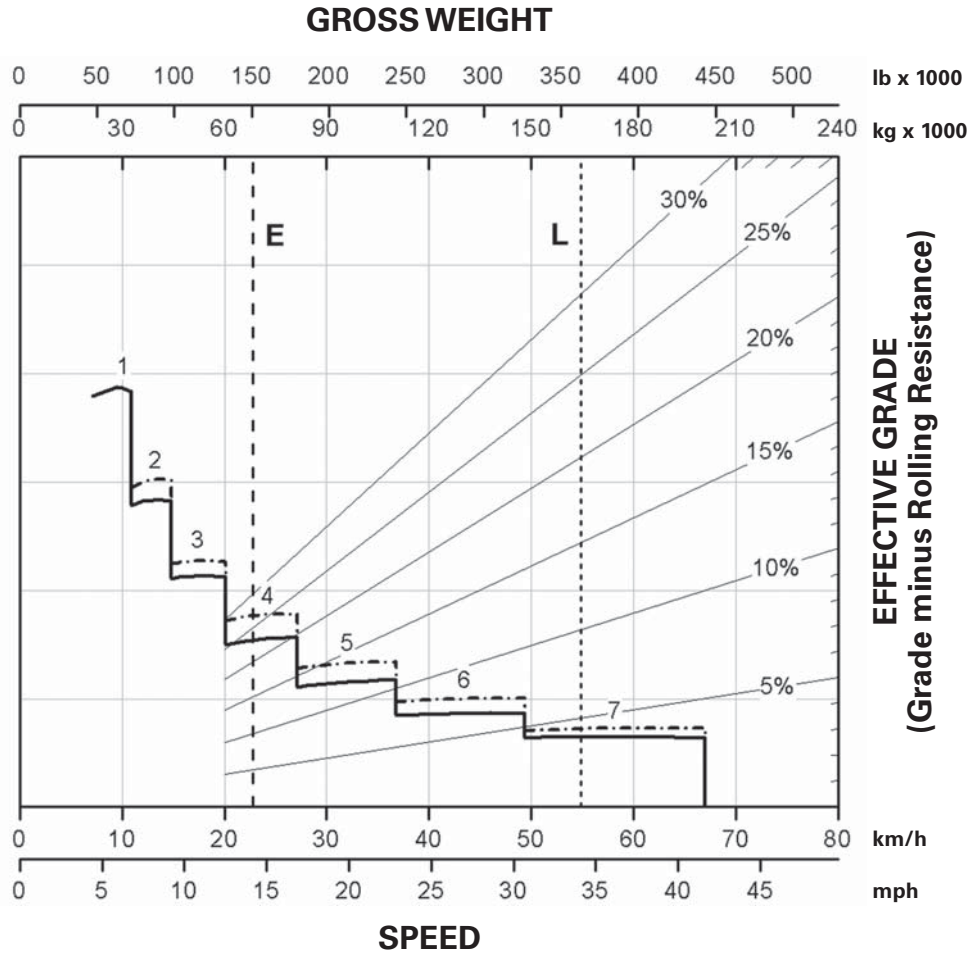

- KEY**
- 1 — 1st Gear
  - 2 — 2nd Gear
  - 3 — 3rd Gear
  - 4 — 4th Gear
  - 5 — 5th Gear
  - 6 — 6th Gear
  - 7 — 7th Gear

- KEY**
- E — Empty 67 923 kg (149,744 lb)
  - L — Target GMW 164 654 kg (363,000 lb)
  - With ARC Only
  - - - - - ARC and Engine Brake

# 777G Brake Performance

- 450 m (1500 ft)
- 600 m (2000 ft)
- 900 m (3000 ft)
- 1500 m (5000 ft)

# Mining & Off-Highway Trucks

## GROSS WEIGHT

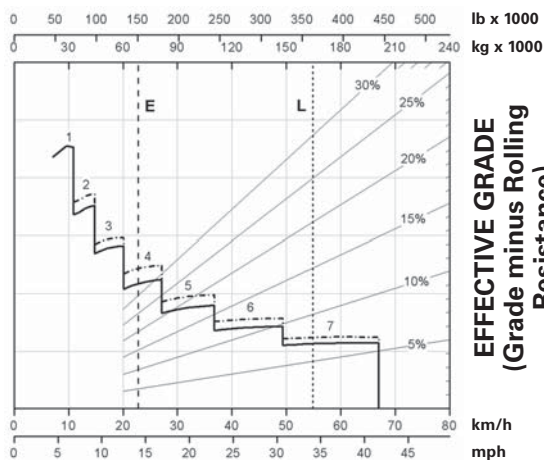

**SPEED**  
GRADE DISTANCE — 450 m (1500 ft)

## GROSS WEIGHT

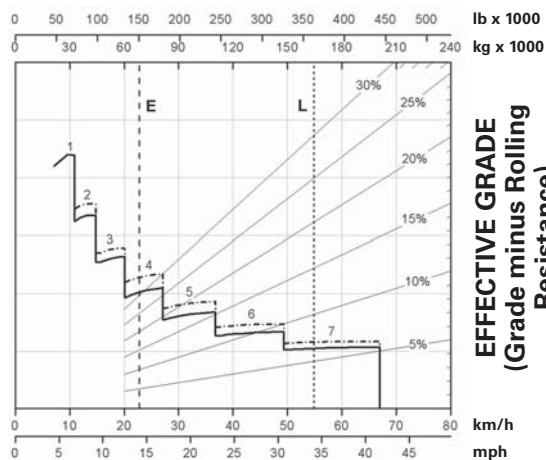

**SPEED**  
GRADE DISTANCE — 600 m (2000 ft)

## GROSS WEIGHT

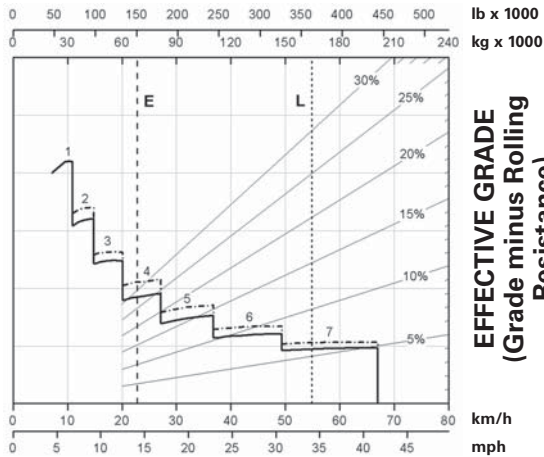

**SPEED**  
GRADE DISTANCE — 900 m (3000 ft)

## GROSS WEIGHT

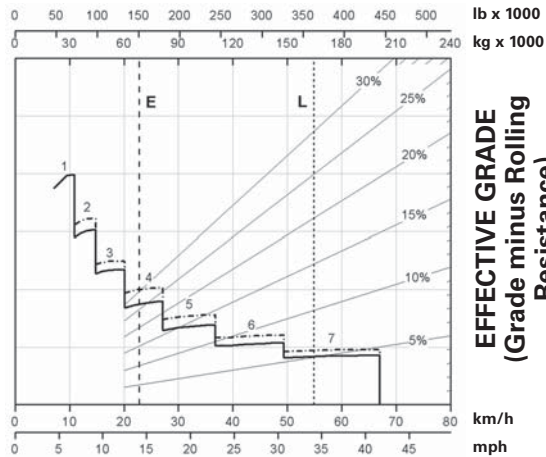

**SPEED**  
GRADE DISTANCE — 1500 m (5000 ft)

### KEY

- 1 — 1st Gear
- 2 — 2nd Gear
- 3 — 3rd Gear
- 4 — 4th Gear
- 5 — 5th Gear
- 6 — 6th Gear
- 7 — 7th Gear

### KEY

- E — Empty 67 923 kg (149,744 lb)
- L — Target GMW 164 654 kg (363,000 lb)
- With ARC Only
- - - - - ARC and Engine Brake

# Mining & Off-Highway Trucks

## 785C Rimpull-Speed-Gradeability

● 33.00R51 Tires\*

● 1433 mm (4'4.4") Tire Radius

### GROSS WEIGHT

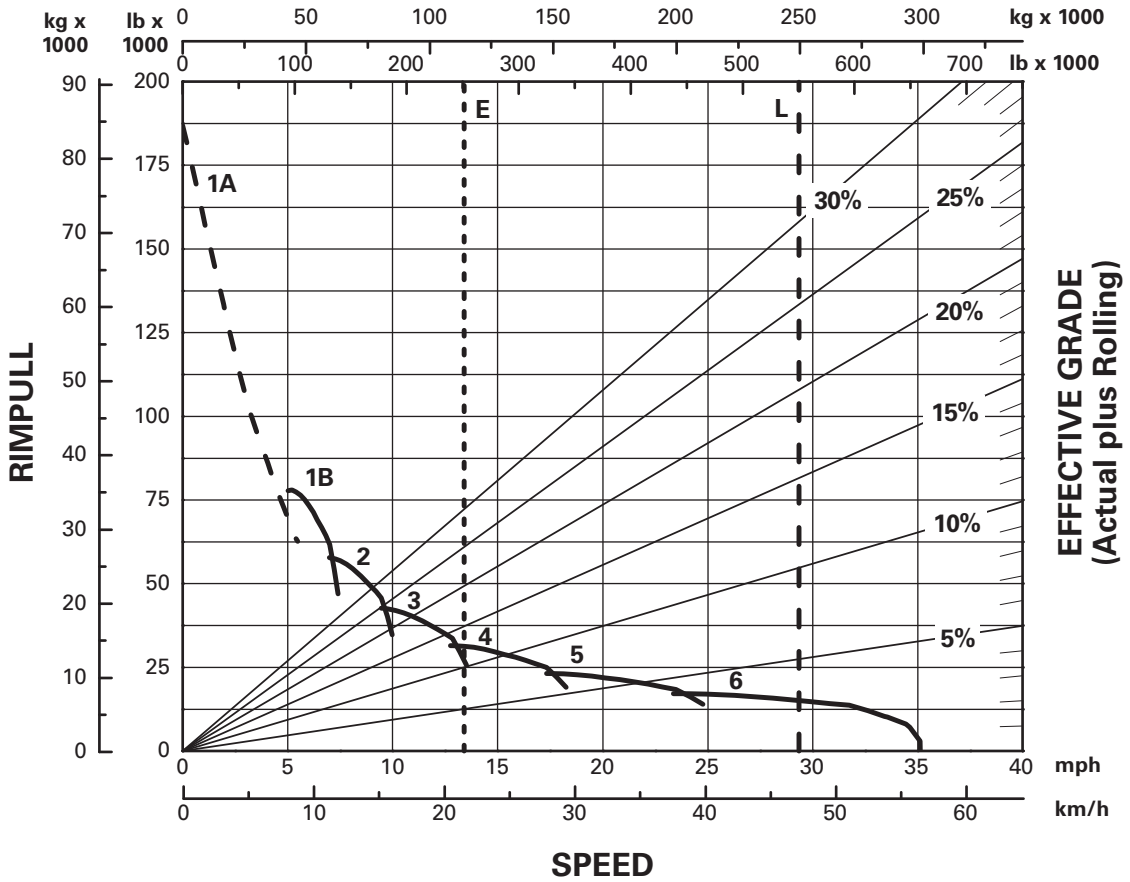

#### KEY

- 1A — 1st Gear (Torque Converter)
- 1B — 1st Gear
- 2 — 2nd Gear
- 3 — 3rd Gear
- 4 — 4th Gear
- 5 — 5th Gear
- 6 — 6th Gear

#### KEY

- E — Empty Operating Weight 115 460 kg (254,546 lb)
- L — Target GMW 249 476 kg (550,000 lb)

\*At Sea Level.

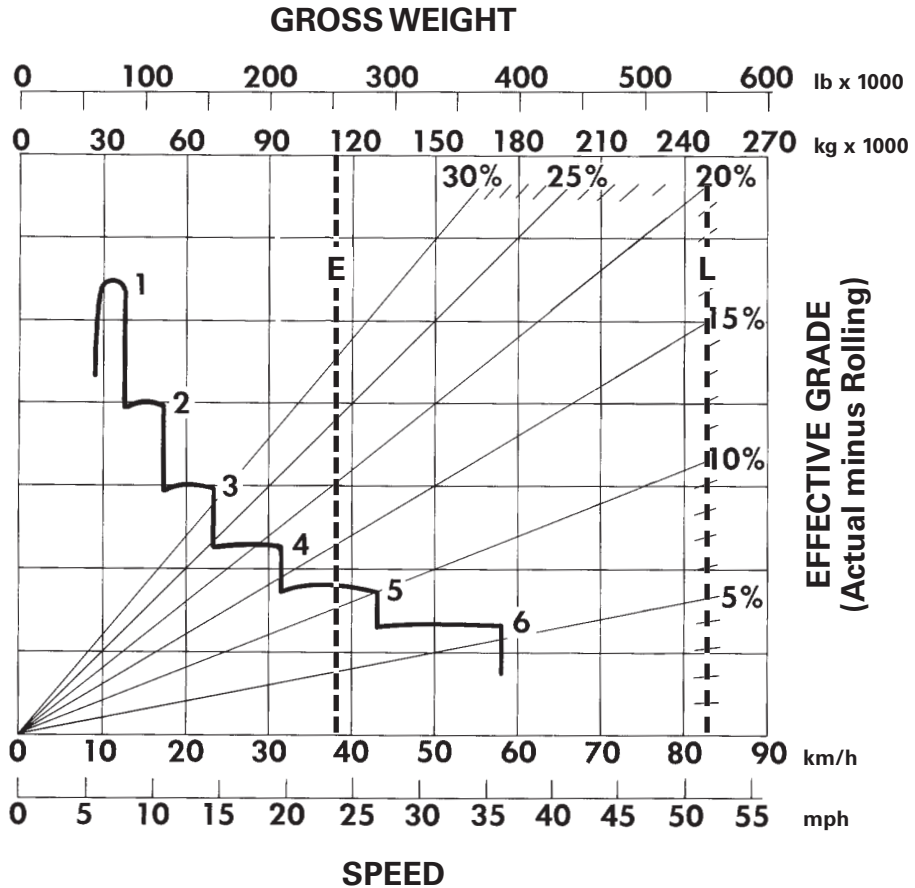

**EFFECTIVE GRADE**  
 (Actual minus Rolling)

- KEY**
- 1 – 1st Gear
  - 2 – 2nd Gear
  - 3 – 3rd Gear
  - 4 – 4th Gear
  - 5 – 5th Gear
  - 6 – 6th Gear

- KEY**
- E – Empty Operating Weight 115 460 kg (254,546 lb)
  - L – Target GMW 249 476 kg (550,000 lb)

# Mining & Off-Highway Trucks

## 785C Brake Performance

- 450 m (1500 ft)
- 600 m (2000 ft)
- 900 m (3000 ft)
- 1500 m (5000 ft)

### GROSS WEIGHT

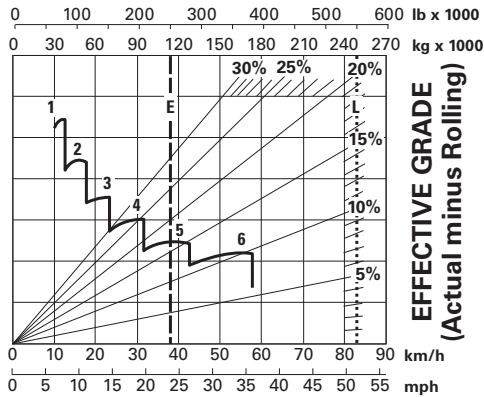

### SPEED

GRADE DISTANCE — 450 m (1500 ft)

### GROSS WEIGHT

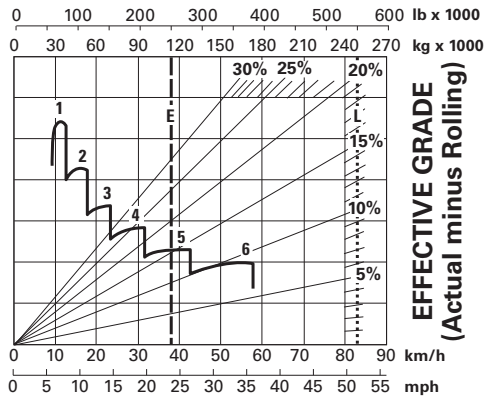

### SPEED

GRADE DISTANCE — 600 m (2000 ft)

### GROSS WEIGHT

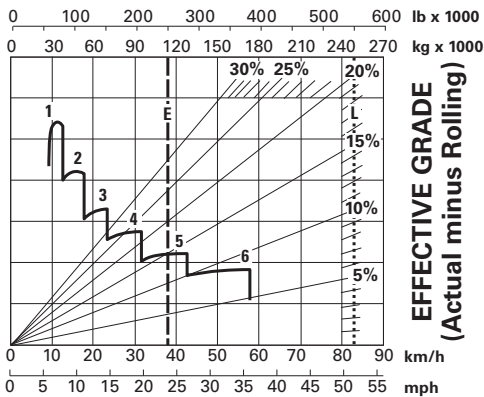

### SPEED

GRADE DISTANCE — 900 m (3000 ft)

### GROSS WEIGHT

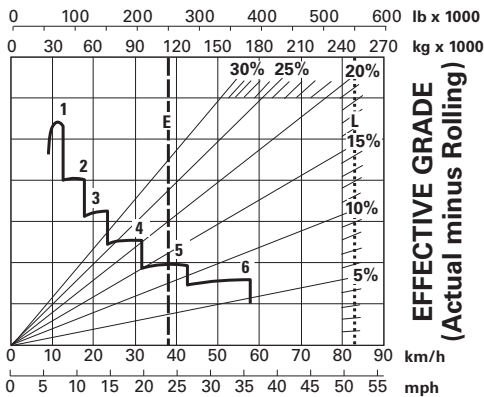

### SPEED

GRADE DISTANCE — 1500 m (5000 ft)

#### KEY

- 1 — 1st Gear
- 2 — 2nd Gear
- 3 — 3rd Gear
- 4 — 4th Gear
- 5 — 5th Gear
- 6 — 6th Gear

#### KEY

- E — Empty Operating Weight 115 460 kg (254,546 lb)
- L — Target GMW 249 476 kg (550,000 lb)

# 785D Rimpull-Speed-Gradeability

● 33.00R51 Tires\*

● 1433 mm (4'8.4") Tire Radius

# Mining & Off-Highway Trucks

## GROSS WEIGHT

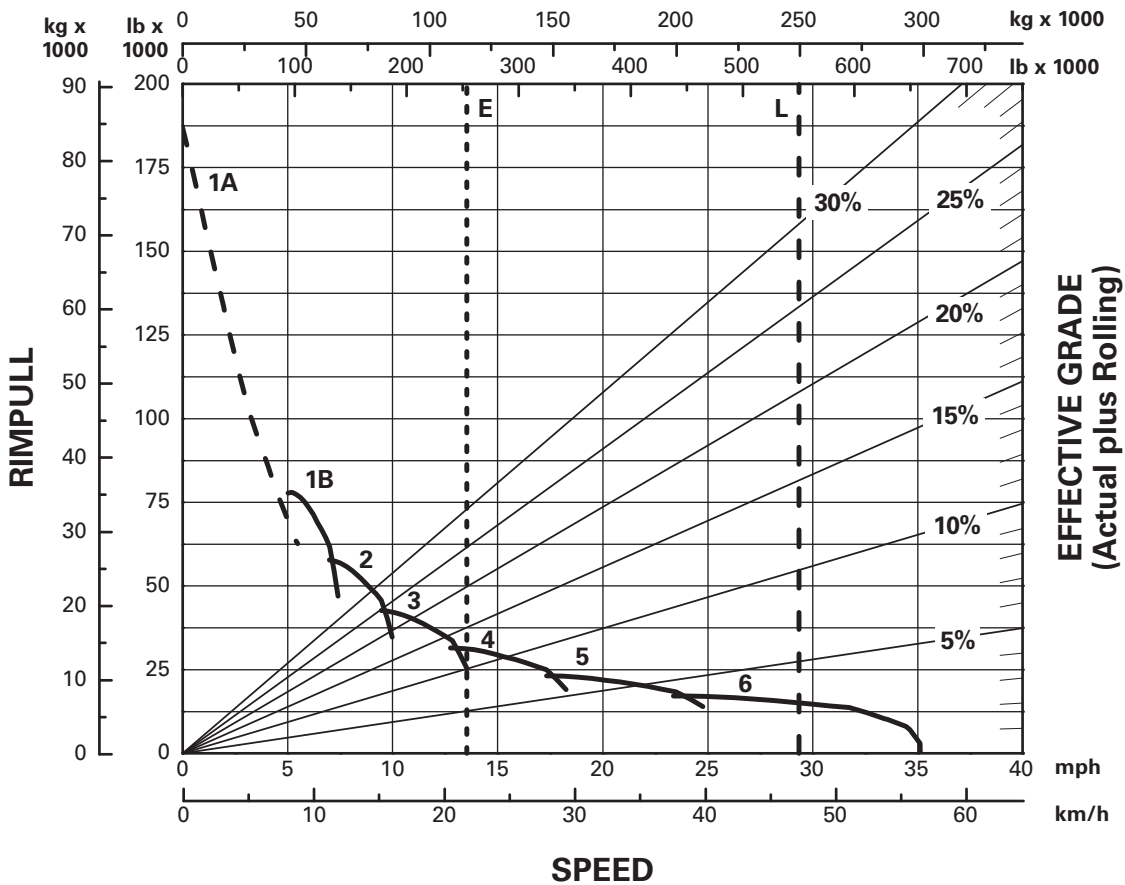

10

### KEY

- 1A — 1st Gear (Torque Converter)
- 1B — 1st Gear
- 2 — 2nd Gear
- 3 — 3rd Gear
- 4 — 4th Gear
- 5 — 5th Gear
- 6 — 6th Gear

### KEY

- E — Empty Operating Weight 116 525 kg (256,894 lb)
- L — Target GMW 249 476 kg (550,000 lb)

\*At Sea Level.

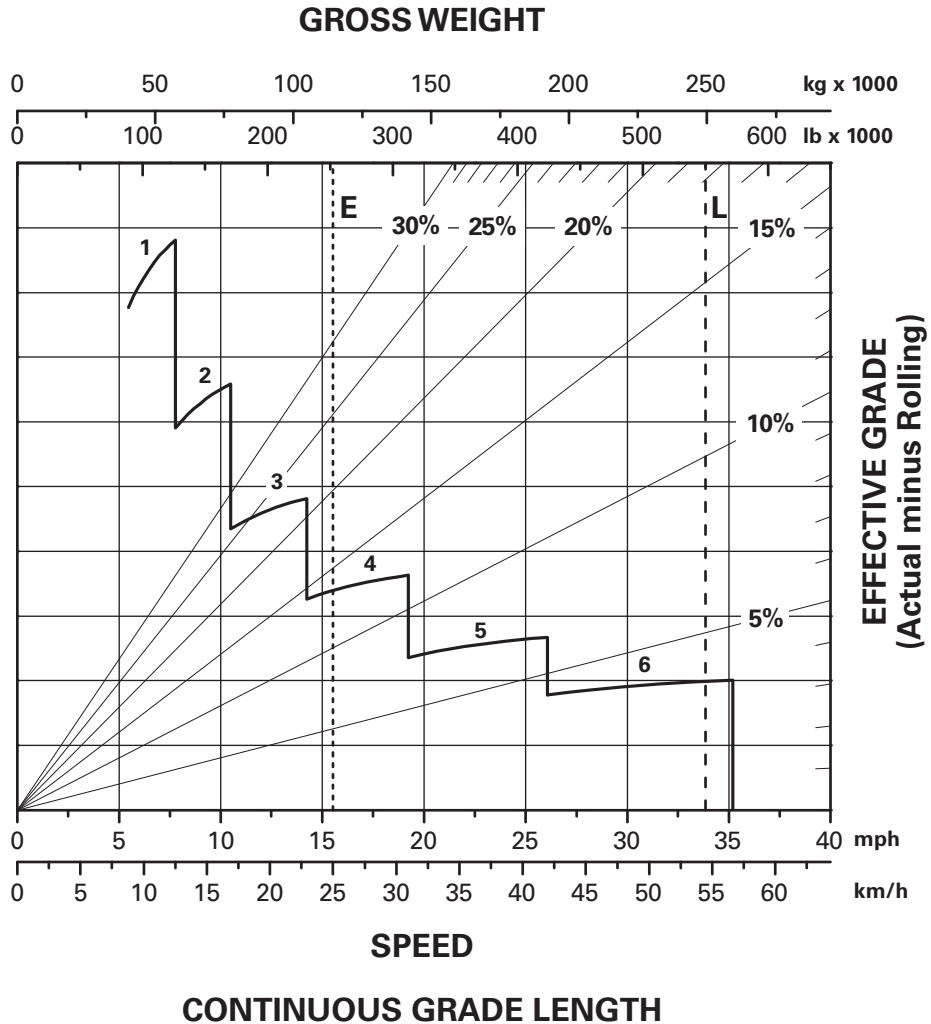

- KEY**
- 1 – 1st Gear
  - 2 – 2nd Gear
  - 3 – 3rd Gear
  - 4 – 4th Gear
  - 5 – 5th Gear
  - 6 – 6th Gear

- KEY**
- E – Empty Operating Weight 116 525 kg (256,894 lb)
  - L – Target GMW 249 476 kg (550,000 lb)

\*At Sea Level.

# 785D Brake Performance

- 450 m (1500 ft) ● 600 m (2000 ft)
- 900 m (3000 ft) ● 1500 m (5000 ft)

# Mining & Off-Highway Trucks

## GROSS WEIGHT

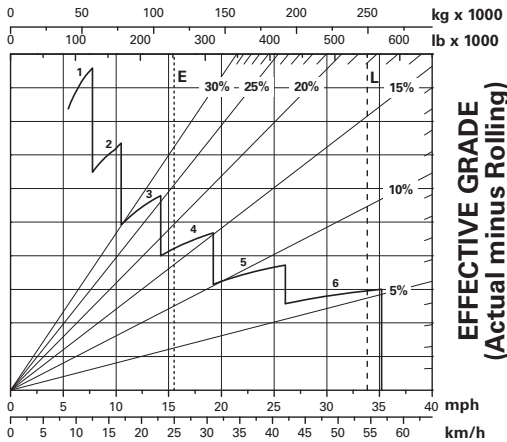

## SPEED

GRADE DISTANCE — 450 m (1500 ft)\*

## GROSS WEIGHT

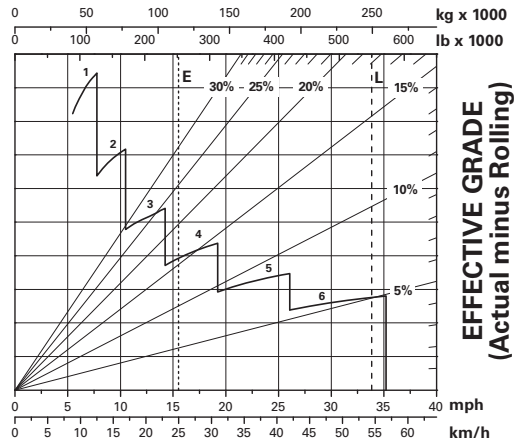

## SPEED

GRADE DISTANCE — 600 m (2000 ft)\*

## GROSS WEIGHT

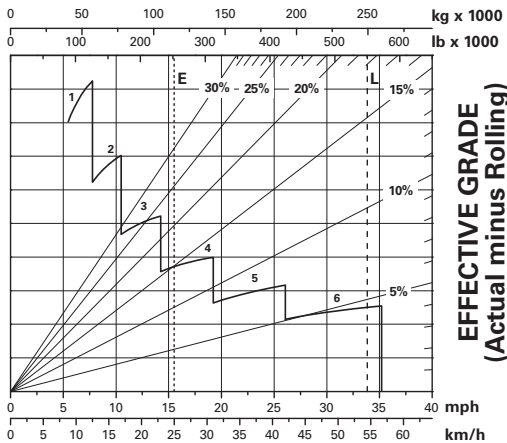

## SPEED

GRADE DISTANCE — 900 m (3000 ft)\*

## GROSS WEIGHT

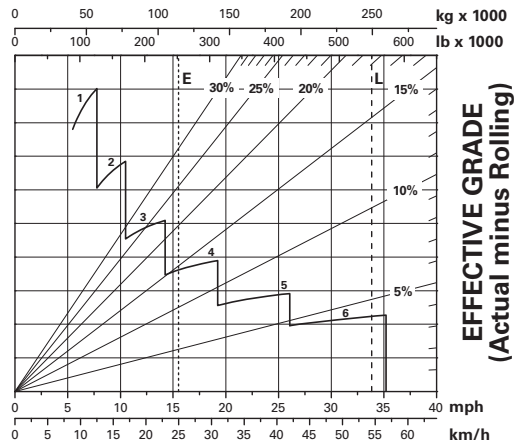

## SPEED

GRADE DISTANCE — 1500 m (5000 ft)\*

### KEY

- 1 — 1st Gear
- 2 — 2nd Gear
- 3 — 3rd Gear
- 4 — 4th Gear
- 5 — 5th Gear
- 6 — 6th Gear

### KEY

- E — Empty Operating Weight 116 525 kg (256,894 lb)
- L — Target GMW 249 476 kg (550,000 lb)

\*At Sea Level.



# Mining & Off-Highway Trucks

## 789D 2100 HP Rimpull-Speed-Gradeability

- 37.00R57 Tires\*\*
- 1593 mm (5'2.7") Tire Radius

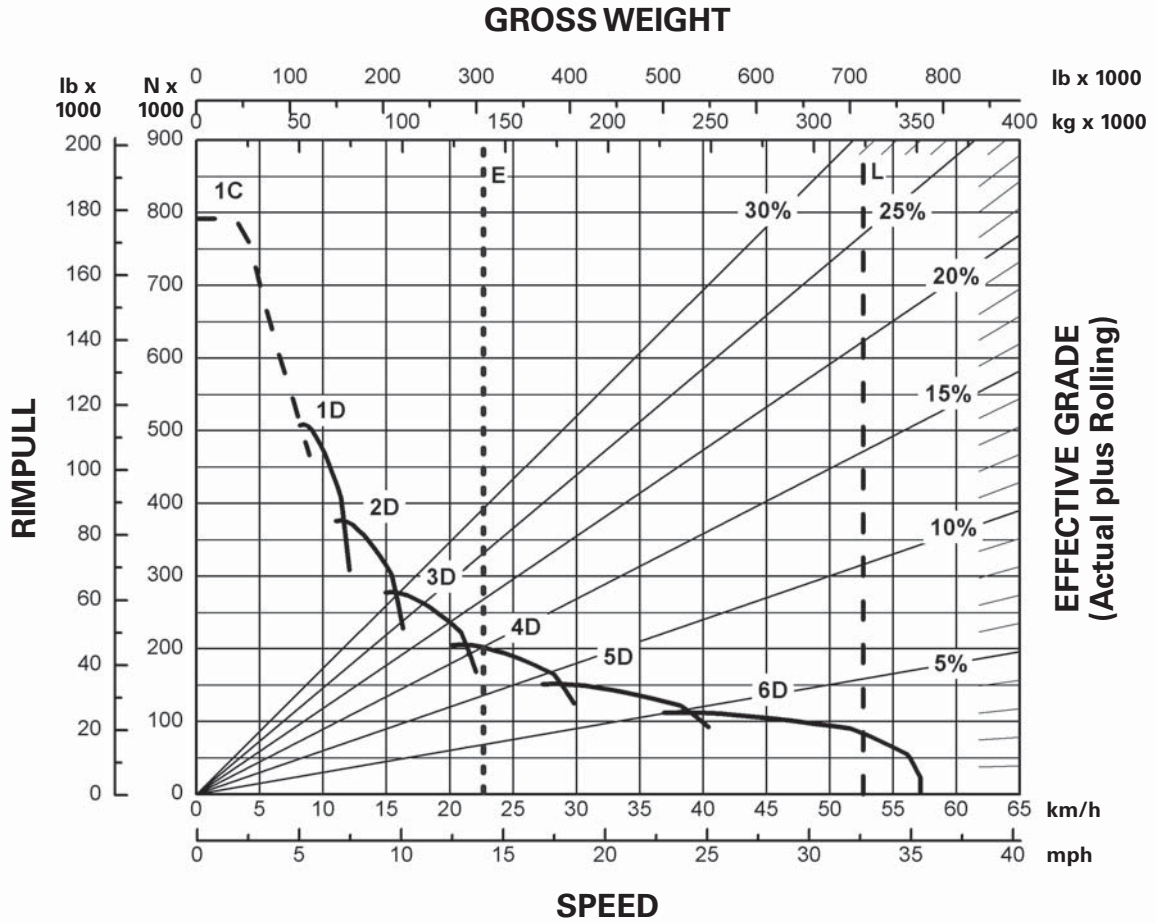

### KEY

- 1C — 1st Gear (Torque Converter)
- 1D — 1st Gear
- 2D — 2nd Gear
- 3D — 3rd Gear
- 4D — 4th Gear
- 5D — 5th Gear
- 6D — 6th Gear

### KEY

- E — Empty Operating Weight 141 214 kg (311,324 lb)\*
- L — Target GMW 324 319 kg (715,000 lb)

\*Truck equipped with sideboards and liners.  
\*\*At Sea Level.

# 789D 1900 HP Rimpull-Speed-Gradeability

# Mining & Off-Highway Trucks

- 37.00R57 Tires\*\*
- 1593 mm (5'2.7") Tire Radius

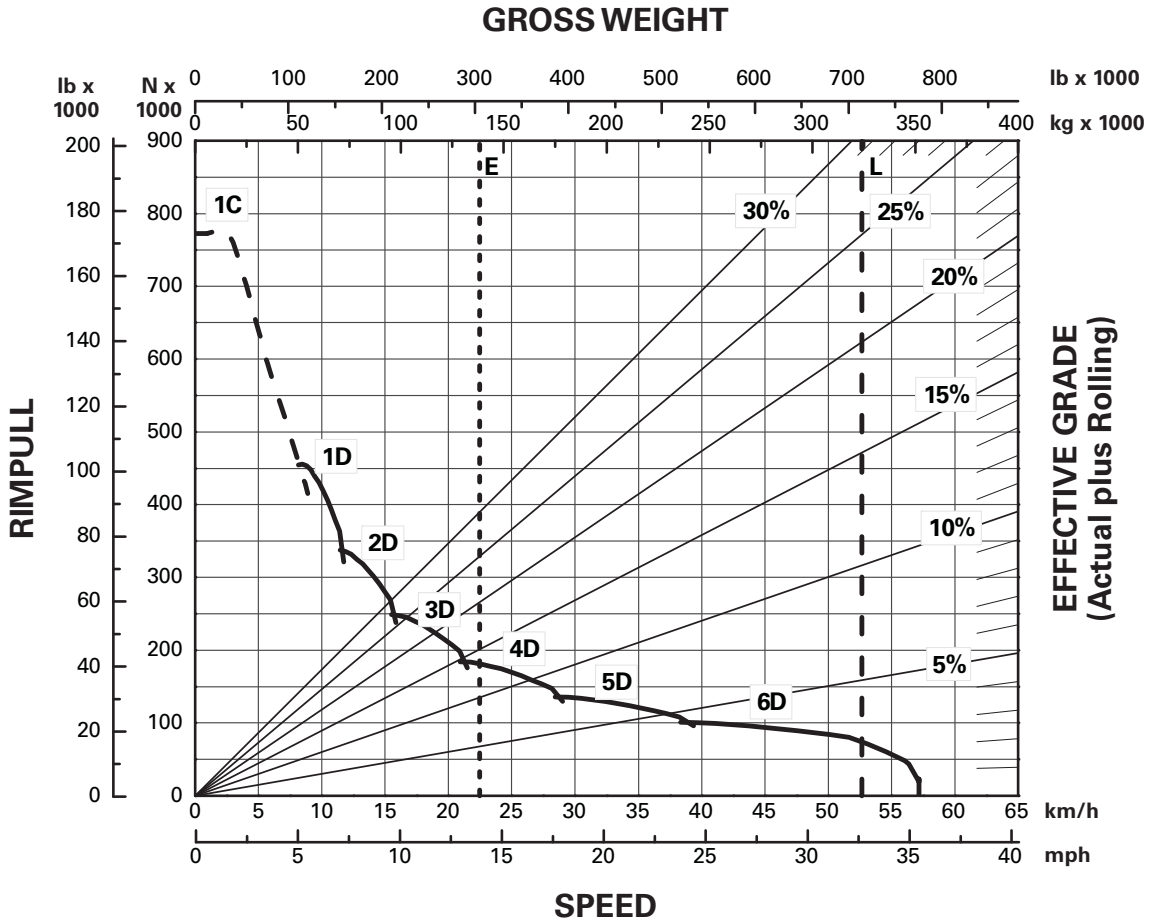

**KEY**

- 1C — 1st Gear (Torque Converter)
- 1D — 1st Gear
- 2D — 2nd Gear
- 3D — 3rd Gear
- 4D — 4th Gear
- 5D — 5th Gear
- 6D — 6th Gear

**KEY**

- E — Empty Operating Weight 141 214 kg (311,324 lb)\*
- L — Target GMW 324 319 kg (715,000 lb)

\*Truck equipped with sideboards and liners.  
 \*\*At Sea Level.

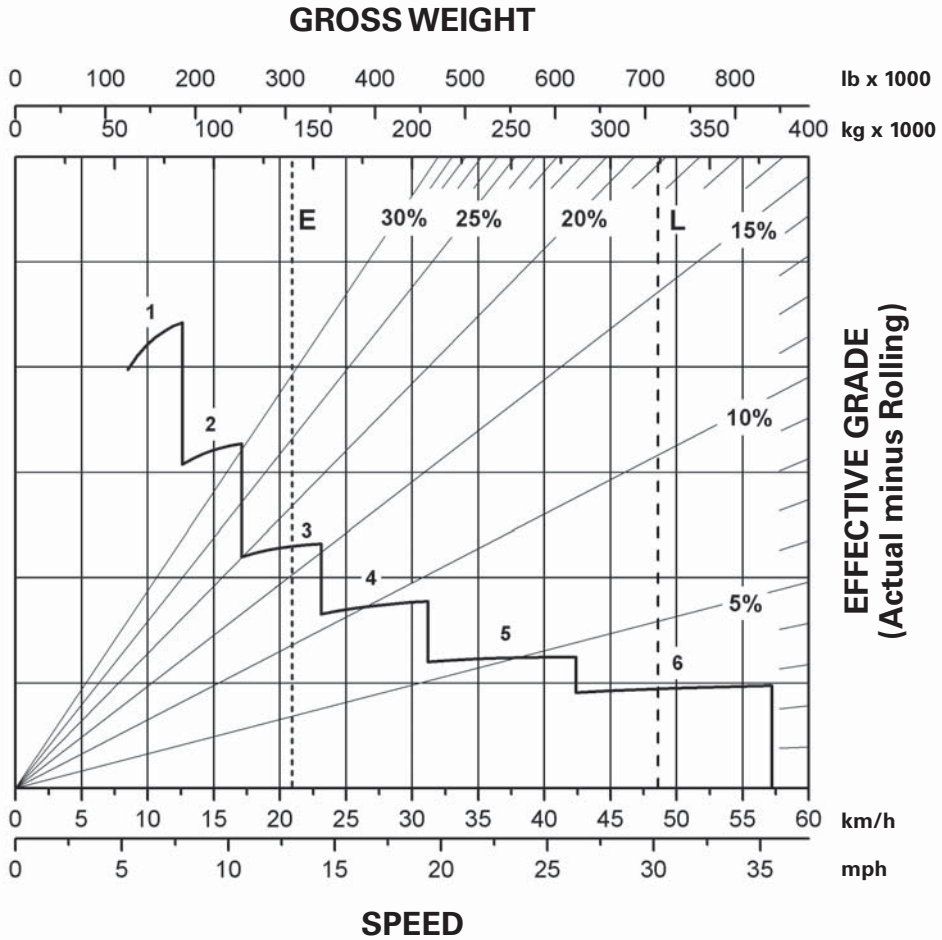

**KEY**

- 1 — 1st Gear
- 2 — 2nd Gear
- 3 — 3rd Gear
- 4 — 4th Gear
- 5 — 5th Gear
- 6 — 6th Gear

**KEY**

- E — Empty Operating Weight 141 214 kg (311,324 lb)\*
- L — Target GMW 324 319 kg (715,000 lb)

\*Truck equipped with sideboards and liners.  
 \*\*At Sea Level.

# 789D Brake Performance

- 450 m (1500 ft)
- 600 m (2000 ft)
- 900 m (3000 ft)
- 1500 m (5000 ft)

# Mining & Off-Highway Trucks

## GROSS WEIGHT

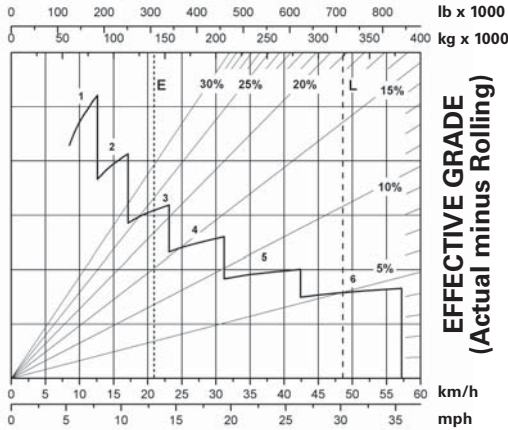

## SPEED

GRADE DISTANCE — 450 m (1500 ft)\*\*

## GROSS WEIGHT

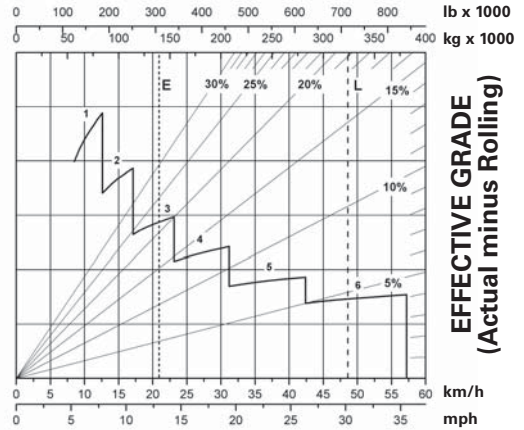

## SPEED

GRADE DISTANCE — 600 m (2000 ft)\*\*

## GROSS WEIGHT

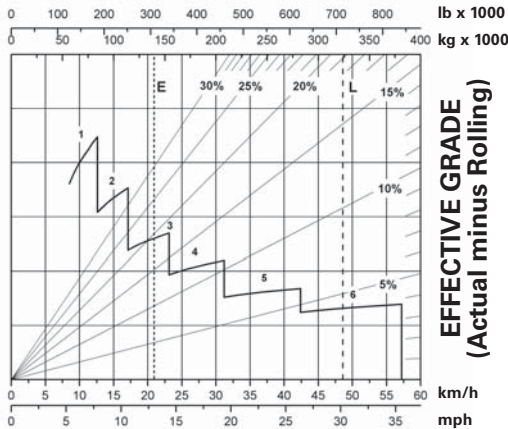

## SPEED

GRADE DISTANCE — 900 m (3000 ft)\*\*

## GROSS WEIGHT

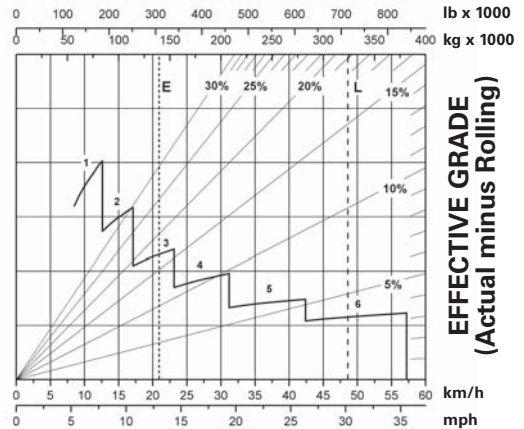

## SPEED

GRADE DISTANCE — 1500 m (5000 ft)\*\*

### KEY

- 1 — 1st Gear
- 2 — 2nd Gear
- 3 — 3rd Gear
- 4 — 4th Gear
- 5 — 5th Gear
- 6 — 6th Gear

### KEY

- E — Empty Operating Weight 141 214 kg (311,324 lb)\*
- L — Target GMW 324 319 kg (715,000 lb)

\*Truck equipped with sideboards and liners.  
 \*\*At Sea Level.

# Mining & Off-Highway Trucks

## 793D Rimpull-Speed-Gradeability

- Standard Arrangement\*
- 40.00R57 Tires
- 1778 mm (5'10") Tire Radius

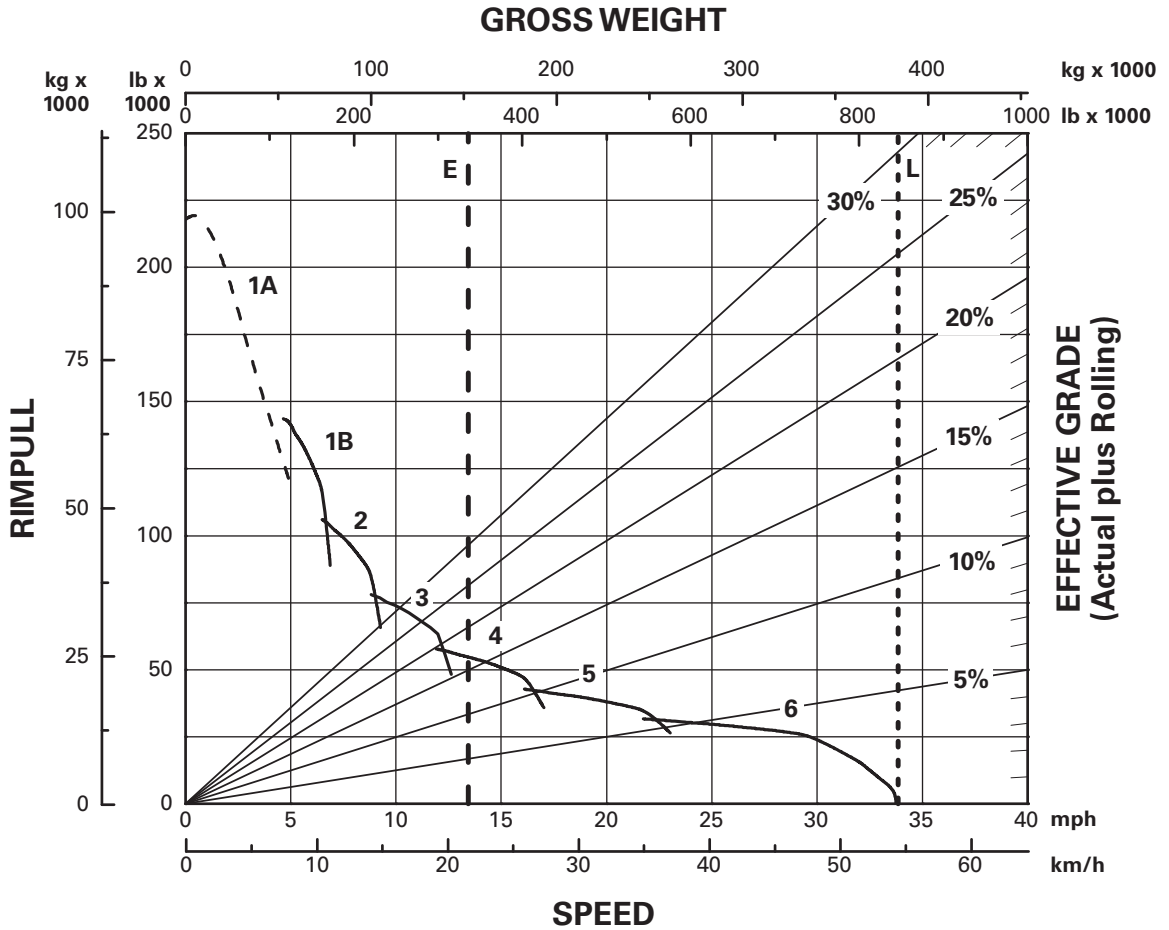

### KEY

- 1A — 1st Gear (Torque Converter)
- 1B — 1st Gear
- 2 — 2nd Gear
- 3 — 3rd Gear
- 4 — 4th Gear
- 5 — 5th Gear
- 6 — 6th Gear

### KEY

- E — Empty Operating Weight 154 729 kg (341,119 lb)
- L — Target GMW 383 740 kg (846,000 lb)

\*At Sea Level.

- 793D Brake Performance
- Standard Arrangement\*
  - Continuous Grade Retarding

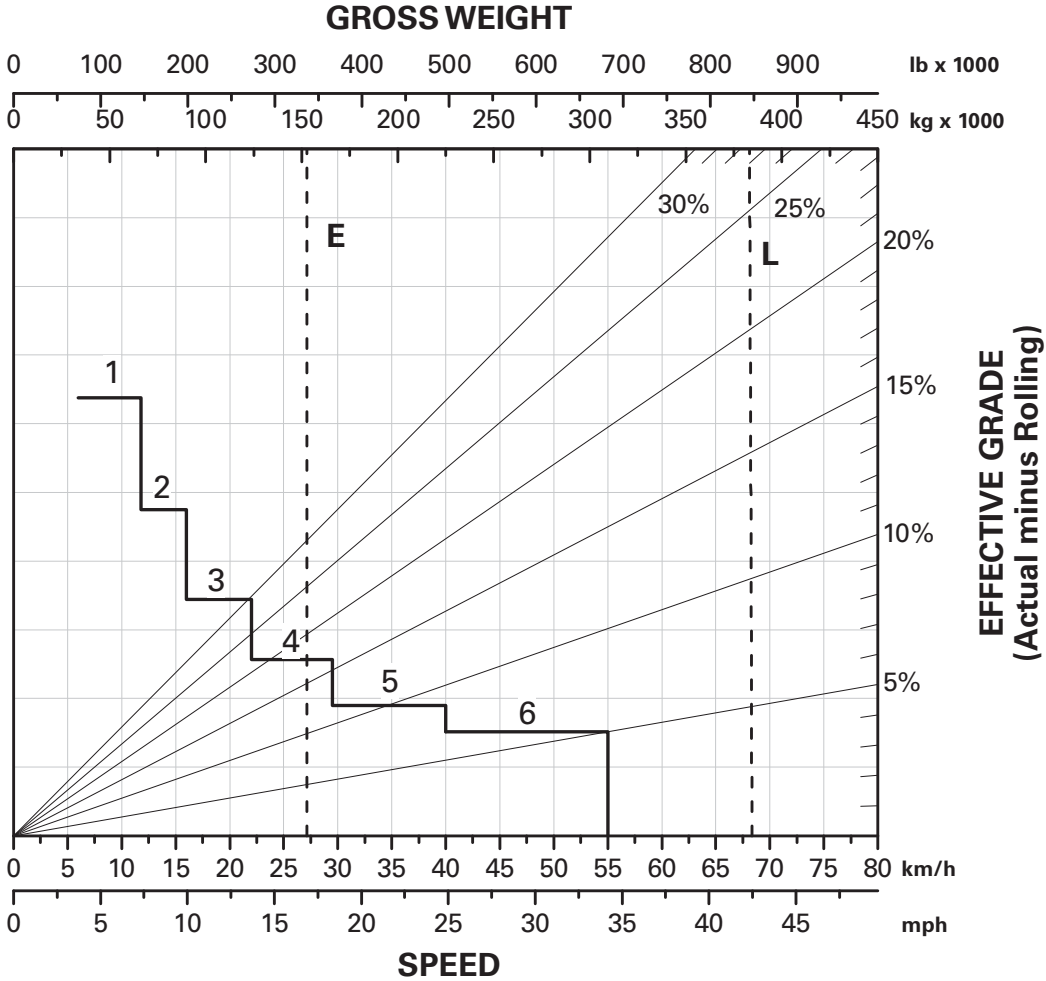

**CONTINUOUS GRADE LENGTH**

- KEY
- 1 – 1st Gear
  - 2 – 2nd Gear
  - 3 – 3rd Gear
  - 4 – 4th Gear
  - 5 – 5th Gear
  - 6 – 6th Gear

- KEY
- E – Empty Operating Weight 154 729 kg (341,119 lb)
  - L – Target GMW 383 740 kg (846,000 lb)

\*At Sea Level.

# Mining & Off-Highway Trucks

## 793D Brake Performance

● Standard Arrangement\*

● 450 m (1500 ft) ● 600 m (2000 ft)

● 900 m (3000 ft) ● 1500 m (5000 ft)

### GROSS WEIGHT

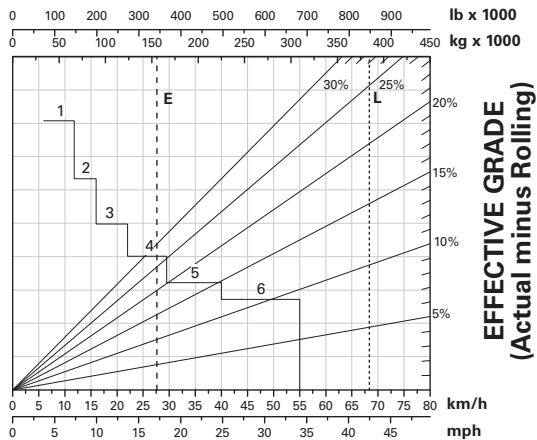

### SPEED

GRADE DISTANCE — 450 m (1500 ft)

### GROSS WEIGHT

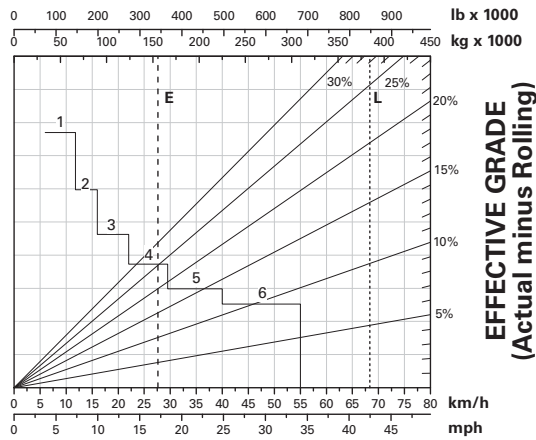

### SPEED

GRADE DISTANCE — 600 m (2000 ft)

### GROSS WEIGHT

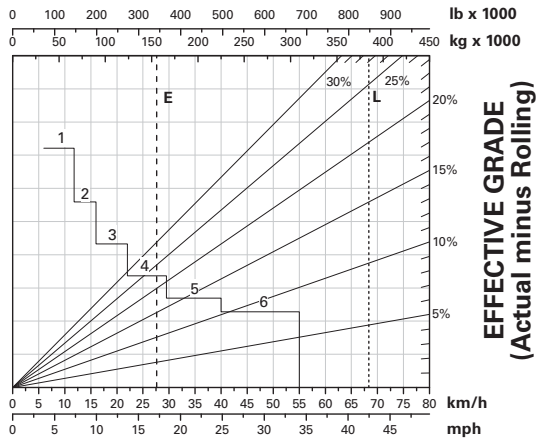

### SPEED

GRADE DISTANCE — 900 m (3000 ft)

### GROSS WEIGHT

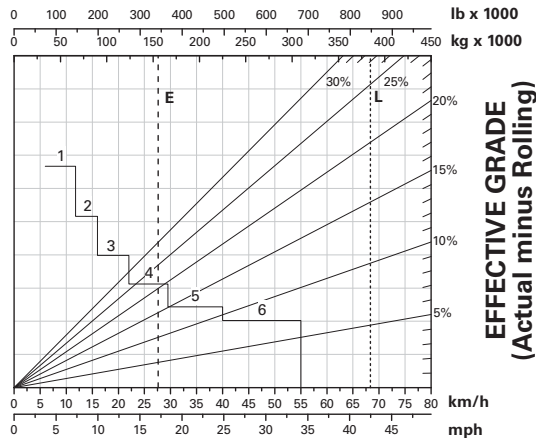

### SPEED

GRADE DISTANCE — 1500 m (5000 ft)

#### KEY

- 1 — 1st Gear
- 2 — 2nd Gear
- 3 — 3rd Gear
- 4 — 4th Gear
- 5 — 5th Gear
- 6 — 6th Gear

#### KEY

- E — Empty Operating Weight 154 729 kg (341,119 lb)
- L — Target GMW 383 740 kg (846,000 lb)

\*At Sea Level.

- 793D Brake Performance
- Additional Retarding Arrangement\*
- Continuous Grade Retarding

## Mining & Off-Highway Trucks

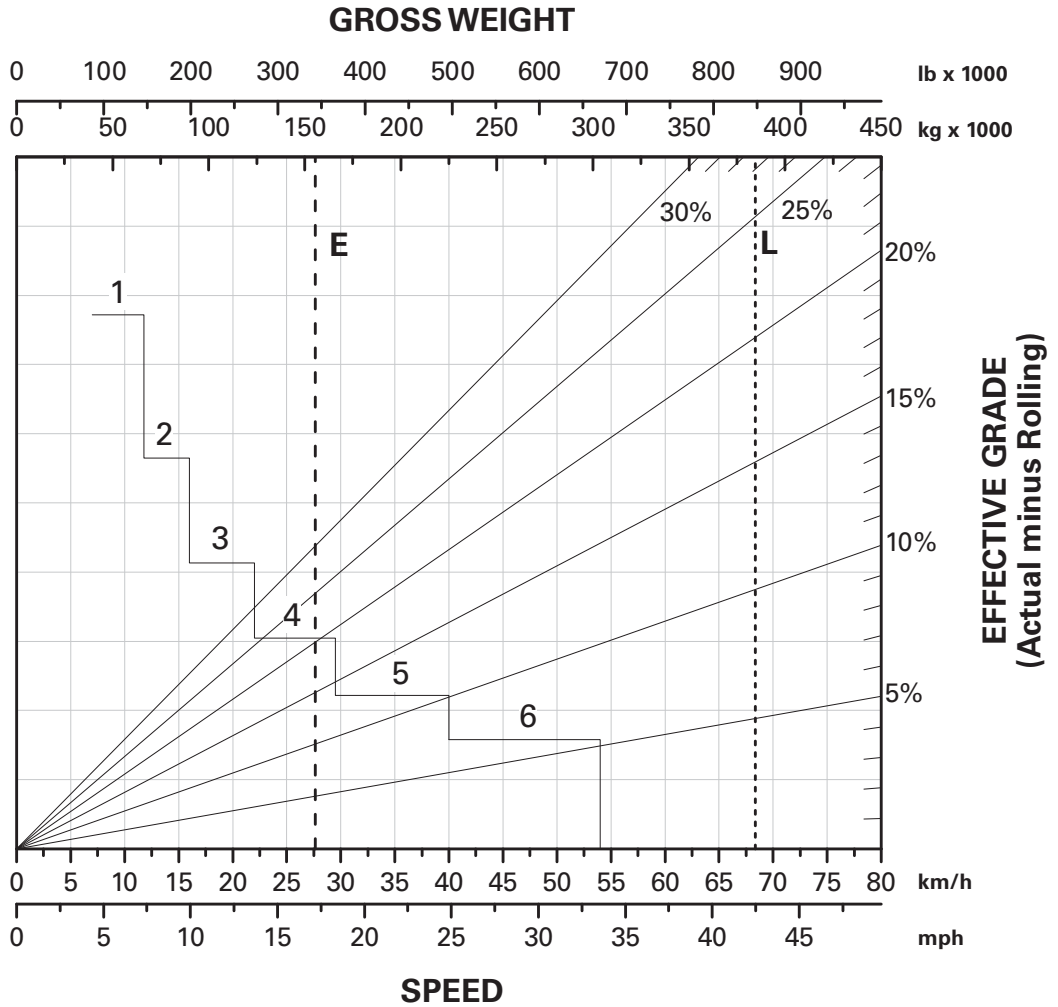

### CONTINUOUS GRADE LENGTH

- KEY**
- 1 — 1st Gear
  - 2 — 2nd Gear
  - 3 — 3rd Gear
  - 4 — 4th Gear
  - 5 — 5th Gear
  - 6 — 6th Gear

- KEY**
- E — Empty Operating Weight 154 729 kg (341,119 lb)
  - L — Target GMW 383 740 kg (846,000 lb)

\*At Sea Level.



# Mining & Off-Highway Trucks

## 793D Brake Performance

- Additional Retarding Arrangement\*
- 450 m (1500 ft) ● 600 m (2000 ft)
- 900 m (3000 ft) ● 1500 m (5000 ft)

### GROSS WEIGHT

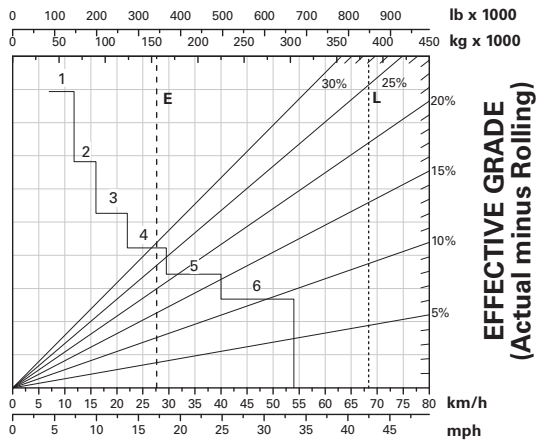

### SPEED

GRADE DISTANCE — 450 m (1500 ft)

### GROSS WEIGHT

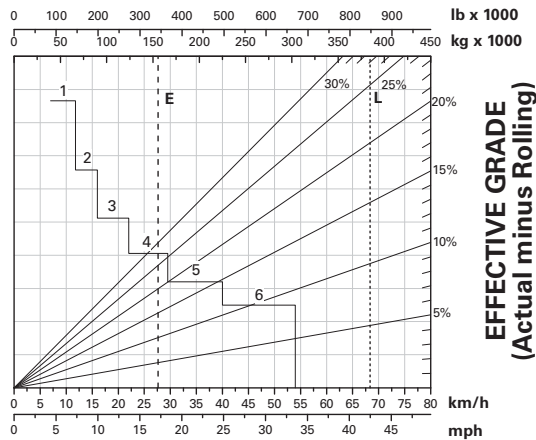

### SPEED

GRADE DISTANCE — 600 m (2000 ft)

### GROSS WEIGHT

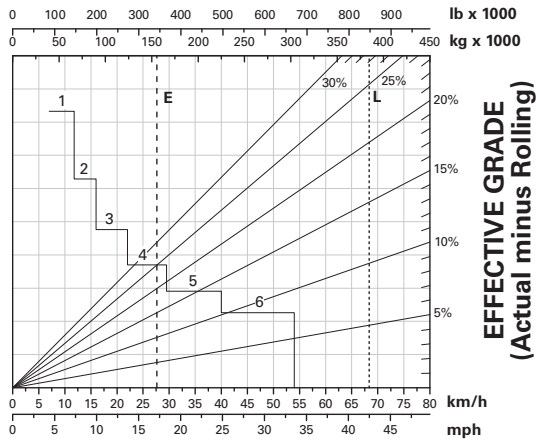

### SPEED

GRADE DISTANCE — 900 m (3000 ft)

### GROSS WEIGHT

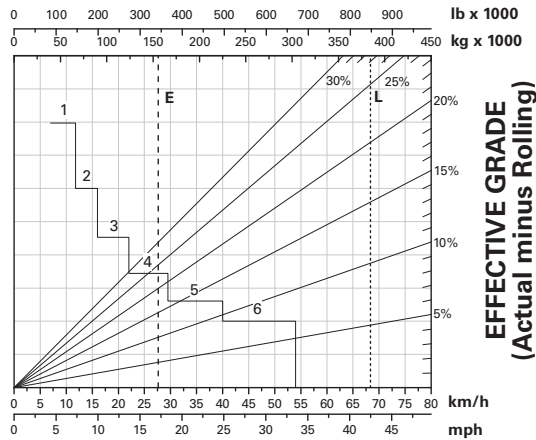

### SPEED

GRADE DISTANCE — 1500 m (5000 ft)

#### KEY

- 1 — 1st Gear
- 2 — 2nd Gear
- 3 — 3rd Gear
- 4 — 4th Gear
- 5 — 5th Gear
- 6 — 6th Gear

#### KEY

- E — Empty Operating Weight 154 729 kg (341,119 lb)
- L — Target GMW 383 740 kg (846,000 lb)

\*At Sea Level.

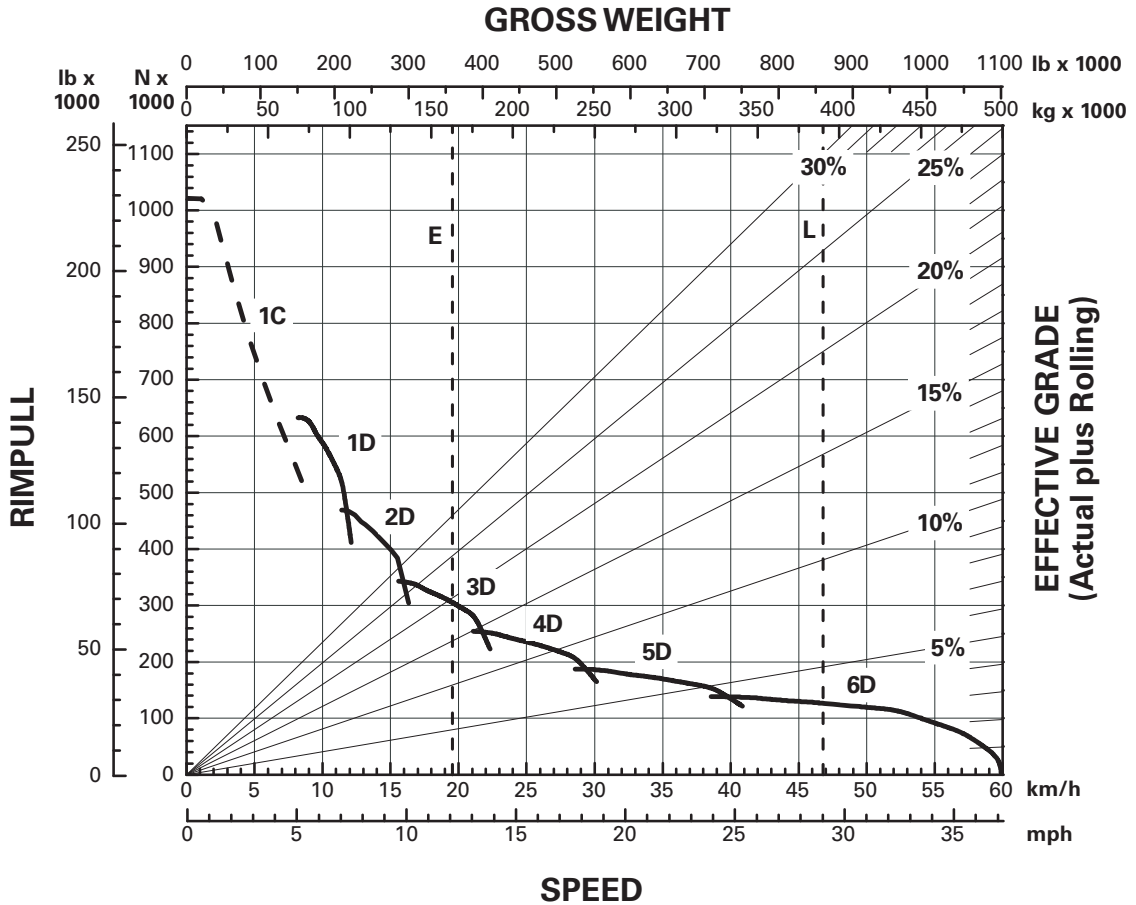

- KEY**
- 1 – 1st Gear
  - 2 – 2nd Gear
  - 3 – 3rd Gear
  - 4 – 4th Gear
  - 5 – 5th Gear
  - 6 – 6th Gear

- KEY**
- E – Empty Operating Weight 165 144 kg (364,080 lb)
  - L – Target GMW 390 090 kg (860,000 lb)

\*At Sea Level.

- Standard Retarding
- Continuous Grade Retarding\*

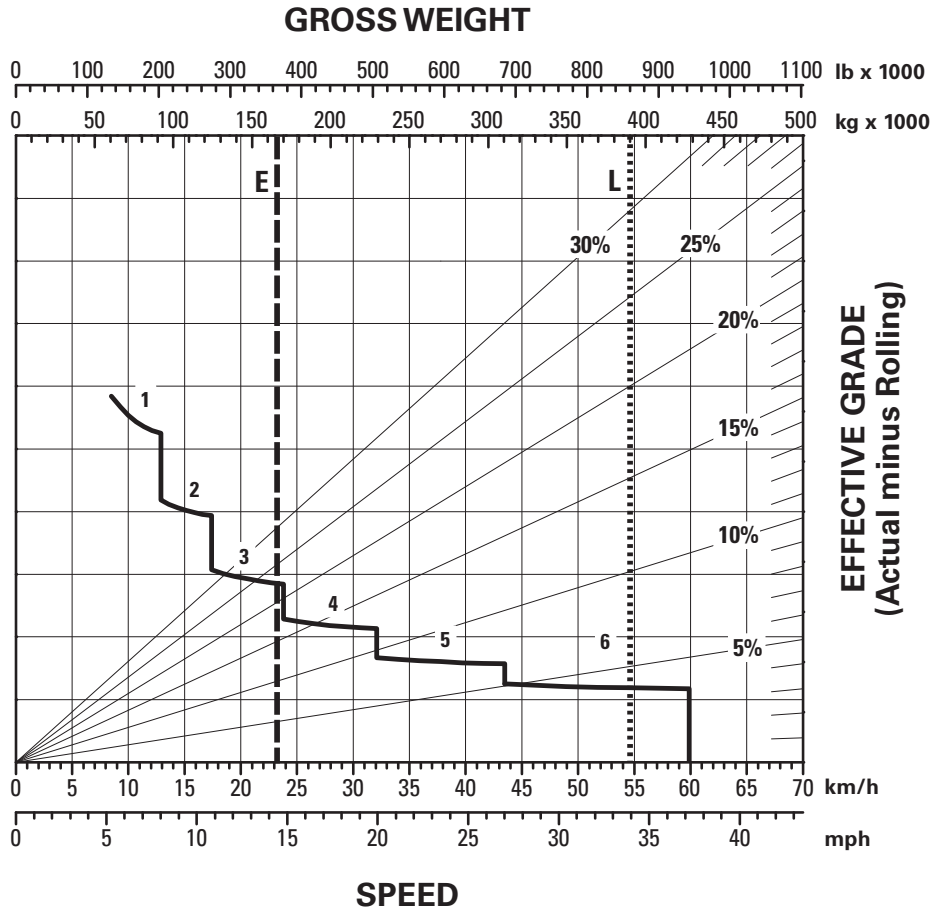

**CONTINUOUS GRADE LENGTH**

**KEY**

- 1 – 1st Gear
- 2 – 2nd Gear
- 3 – 3rd Gear
- 4 – 4th Gear
- 5 – 5th Gear
- 6 – 6th Gear

**KEY**

- E – Empty Operating Weight 165 144 kg (364,080 lb)
- L – Target GMW 390 090 kg (860,000 lb)

\*At Sea Level.

# 793F Brake Performance

- Standard Retarding
- 450 m (1500 ft)
- 600 m (2000 ft)
- 900 m (3000 ft)
- 1500 m (5000 ft)

# Mining & Off-Highway Trucks

## GROSS WEIGHT

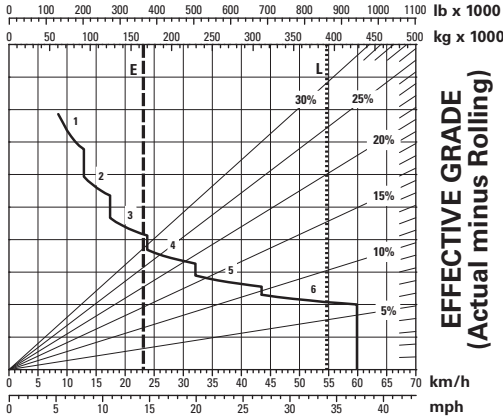

## SPEED

GRADE DISTANCE — 450 m (1500 ft)\*

## GROSS WEIGHT

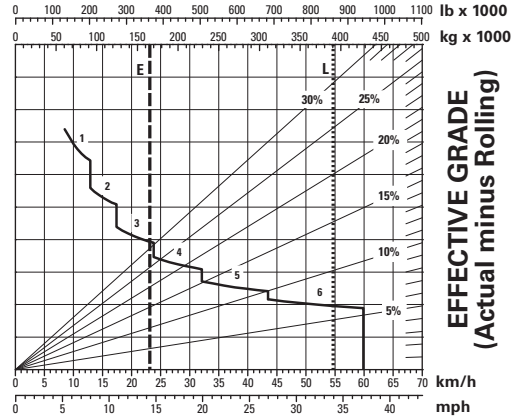

## SPEED

GRADE DISTANCE — 600 m (2000 ft)\*

## GROSS WEIGHT

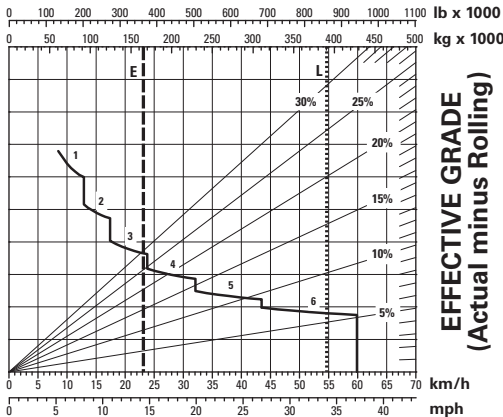

## SPEED

GRADE DISTANCE — 900 m (3000 ft)\*

## GROSS WEIGHT

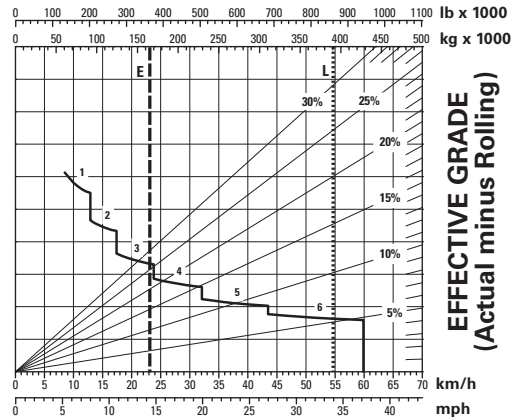

## SPEED

GRADE DISTANCE — 1500 m (5000 ft)\*

### KEY

- 1 — 1st Gear
- 2 — 2nd Gear
- 3 — 3rd Gear
- 4 — 4th Gear
- 5 — 5th Gear
- 6 — 6th Gear

### KEY

- E — Empty Operating Weight 165 144 kg (364,080 lb)
- L — Target GMW 390 090 kg (860,000 lb)

\*At Sea Level.

- Additional Retarding
- Continuous Grade Retarding\*

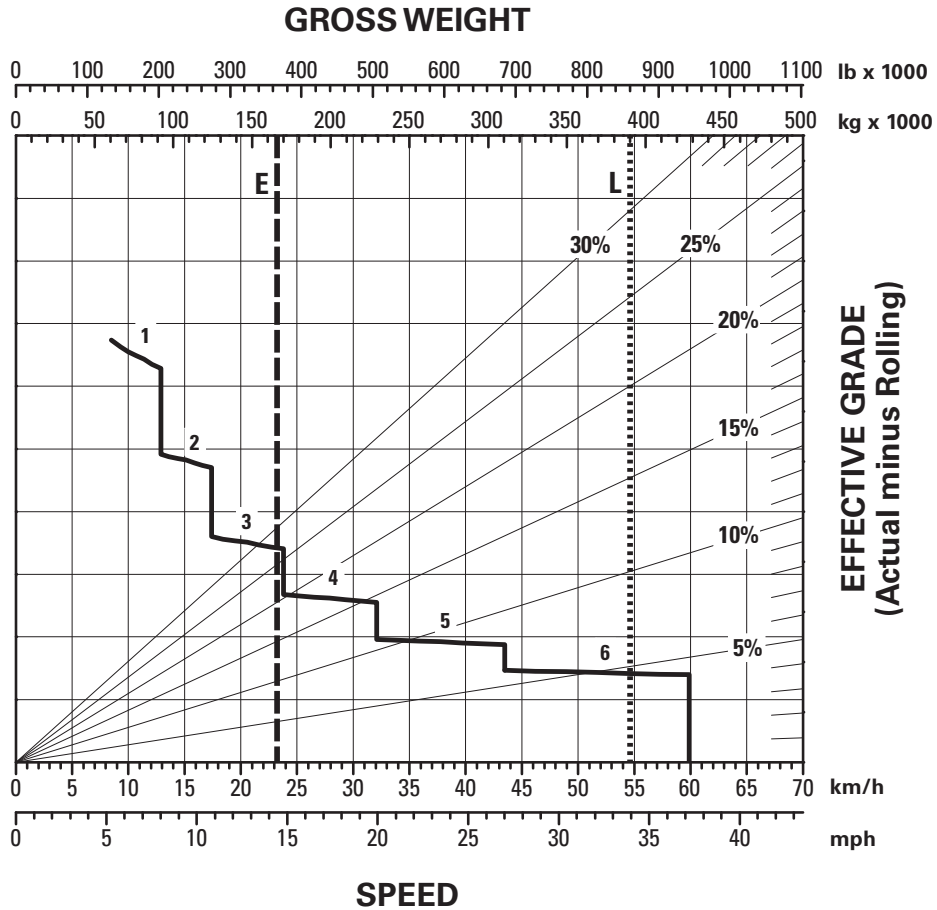

**CONTINUOUS GRADE LENGTH**

**KEY**

- 1 — 1st Gear
- 2 — 2nd Gear
- 3 — 3rd Gear
- 4 — 4th Gear
- 5 — 5th Gear
- 6 — 6th Gear

**KEY**

- E — Empty Operating Weight 165 144 kg (364,080 lb)
- L — Target GMW 390 090 kg (860,000 lb)

\*At Sea Level.

# 793F Brake Performance

# Mining & Off-Highway Trucks

- Additional Retarding
- 450 m (1500 ft)
- 600 m (2000 ft)
- 900 m (3000 ft)
- 1500 m (5000 ft)

## GROSS WEIGHT

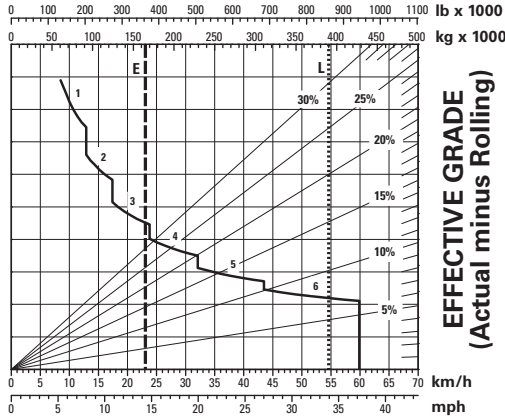

## SPEED

GRADE DISTANCE — 450 m (1500 ft)\*

## GROSS WEIGHT

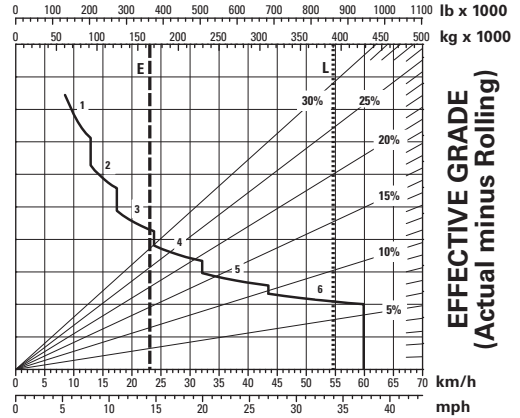

## SPEED

GRADE DISTANCE — 600 m (2000 ft)\*

## GROSS WEIGHT

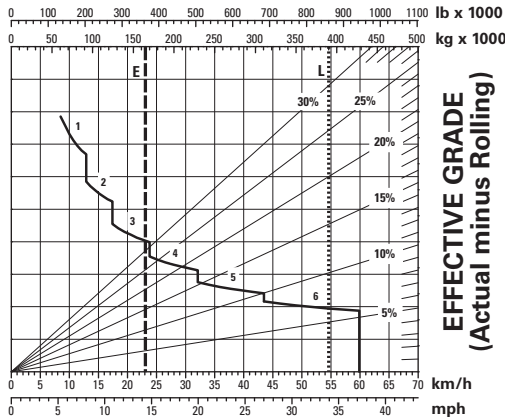

## SPEED

GRADE DISTANCE — 900 m (3000 ft)\*

## GROSS WEIGHT

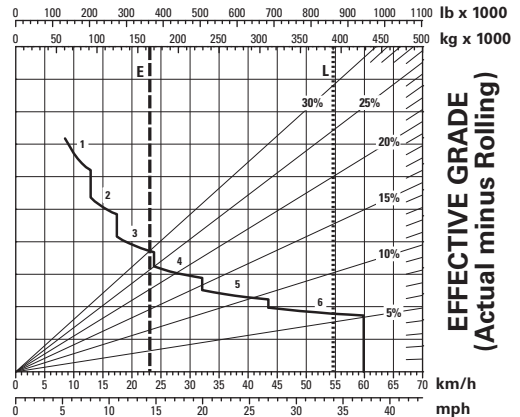

## SPEED

GRADE DISTANCE — 1500 m (5000 ft)\*

### KEY

- 1 — 1st Gear
- 2 — 2nd Gear
- 3 — 3rd Gear
- 4 — 4th Gear
- 5 — 5th Gear
- 6 — 6th Gear

### KEY

- E — Empty Operating Weight 165 144 kg (364,080 lb)
- L — Target GMW 390 090 kg (860,000 lb)

\*At Sea Level.

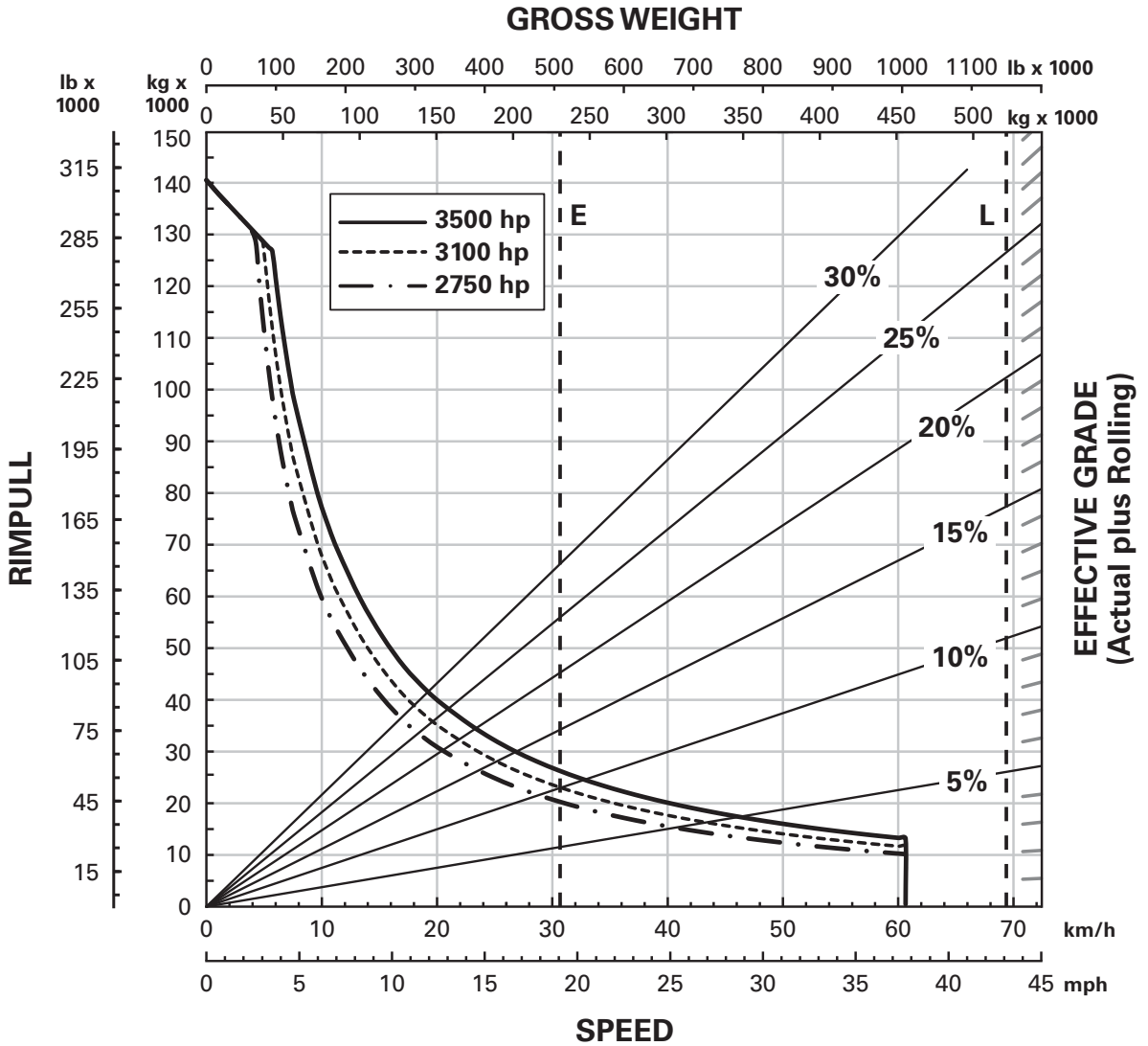

**KEY**

E — Empty Operating Weight 230 631 kg (508,454 lb)

L — Target GMW 521 631 kg (1,150,000 lb)

\*At Sea Level.

- 794 AC Brake Performance
- Continuous Grade Retarding\*
- 53/80R63 Tires

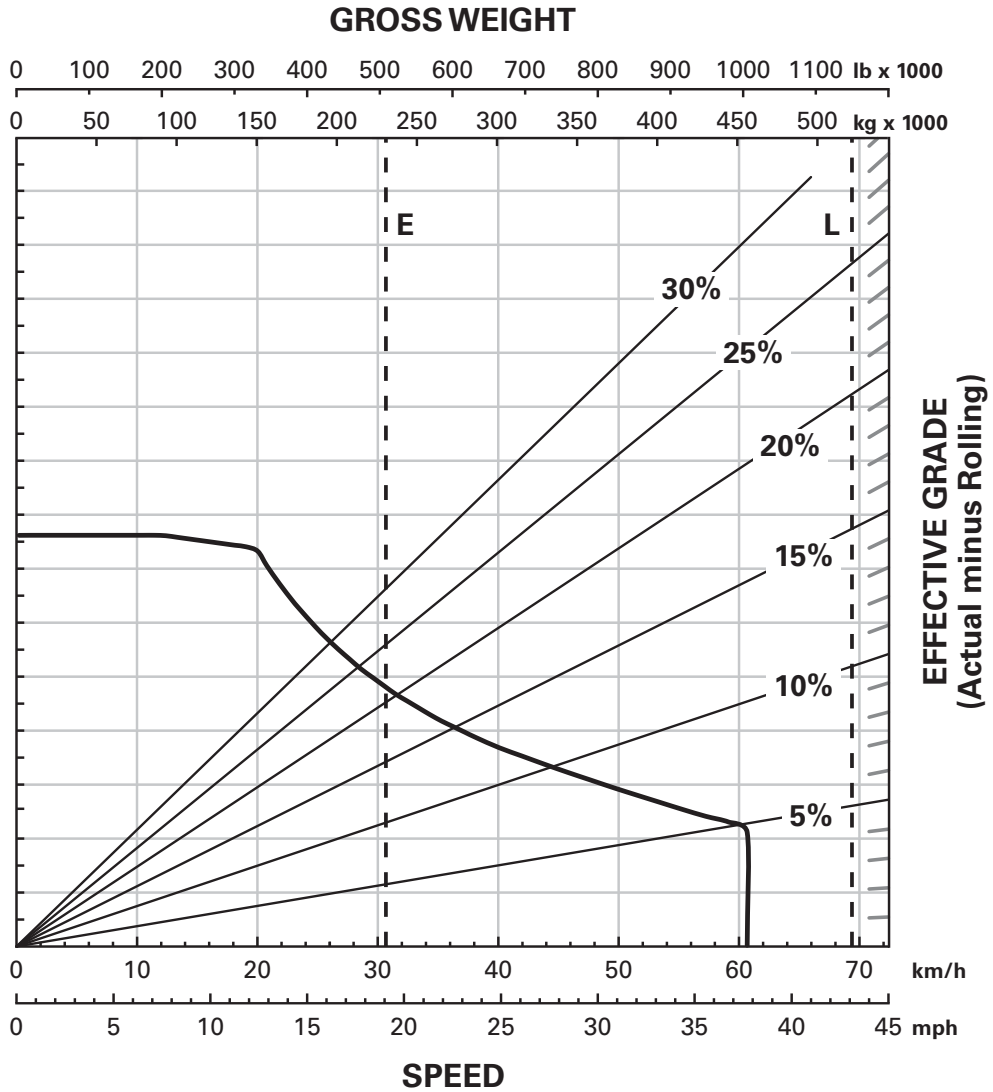

**CONTINUOUS GRADE LENGTH**

**KEY**

E — Empty Operating Weight 230 631 kg (508,454 lb)  
 L — Target GMW 521 631 kg (1,150,000 lb)

\*At Sea Level.



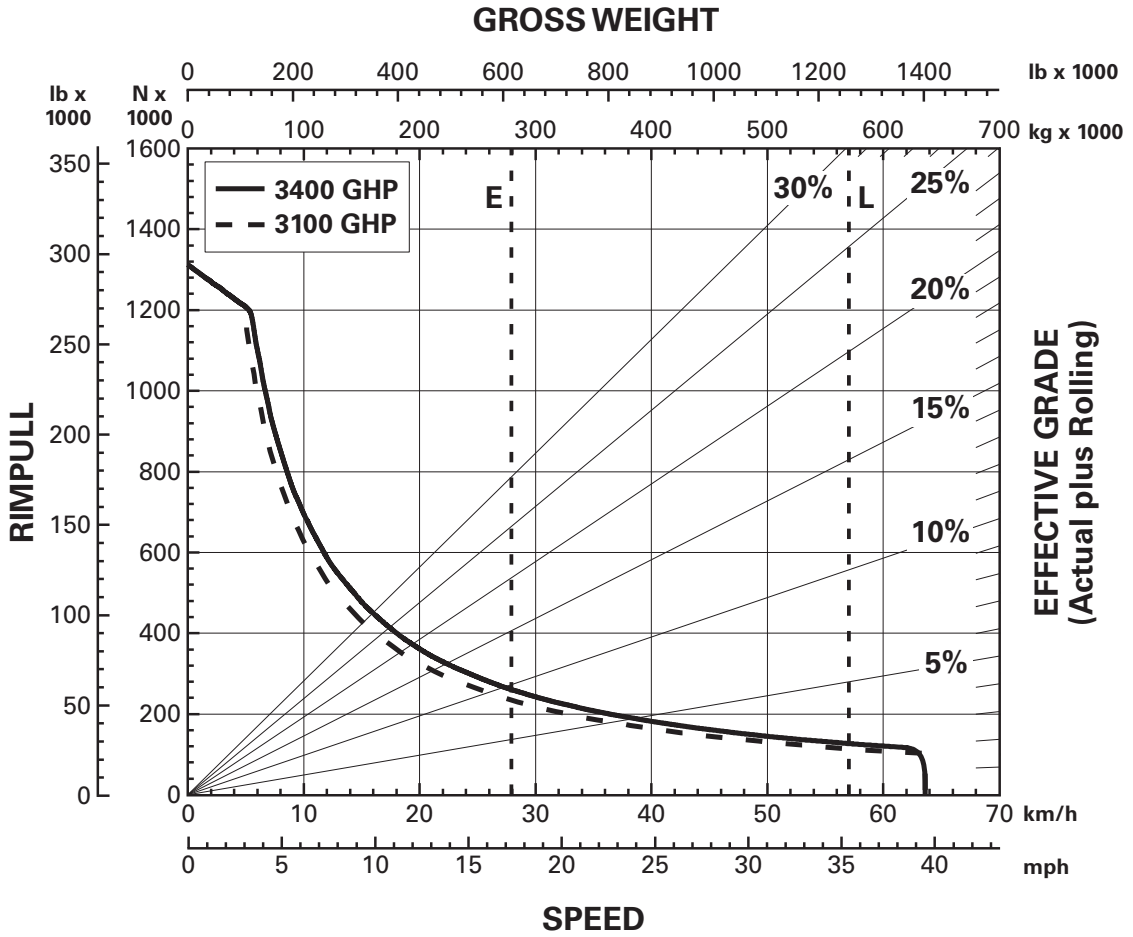

**KEY**

E — Empty Operating Weight 251 933 kg (555,417 lb)

L — Target GMW 570 166 kg (1,257,000 lb)

\*At Sea Level.

- 795F AC Brake Performance
- Continuous Grade Retarding\*
  - 56.80R63 Tires

## Mining & Off-Highway Trucks

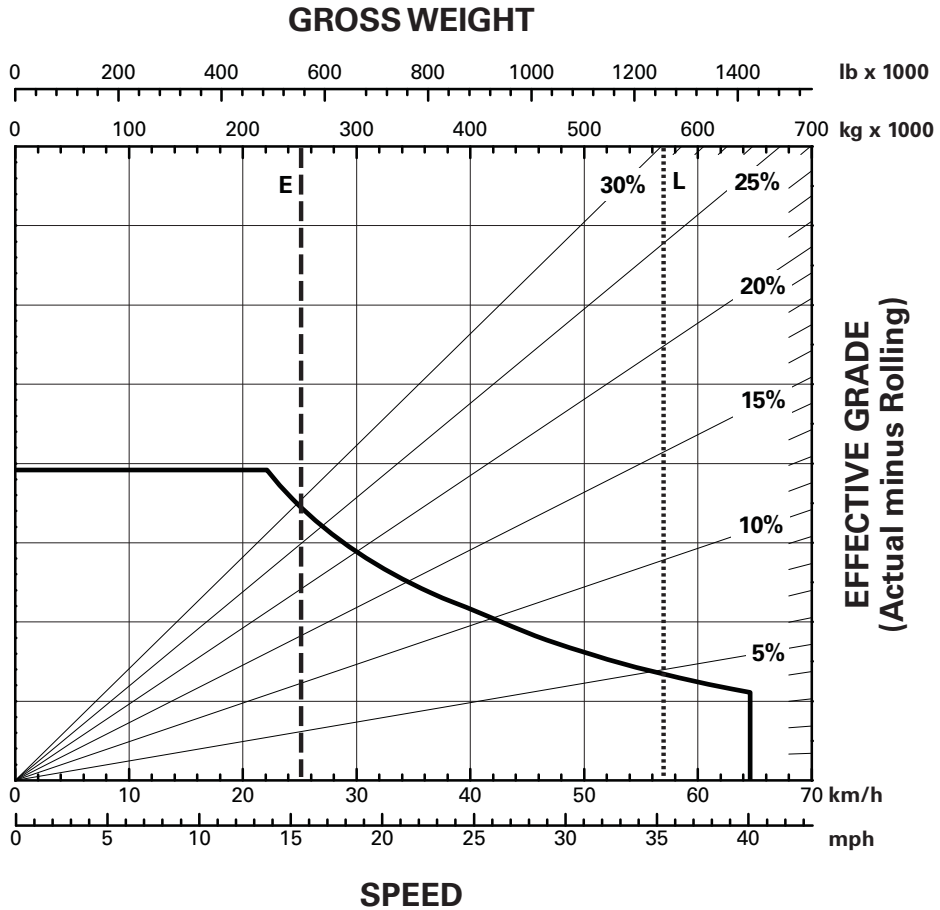

### CONTINUOUS GRADE LENGTH

**KEY**

- E — Empty Operating Weight 251 933 kg (555,417 lb)
- L — Target GMW 570 166 kg (1,257,000 lb)

\*At Sea Level.

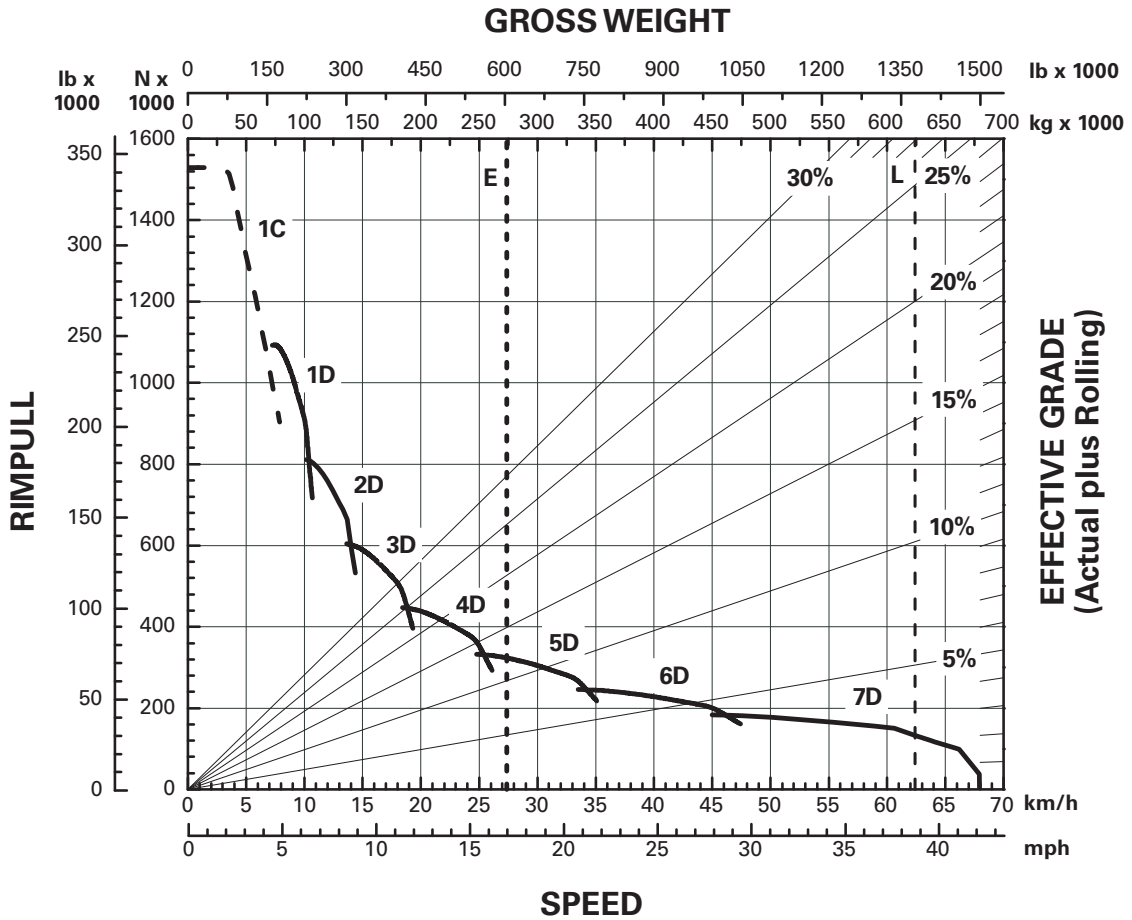

**KEY**

- 1 — 1st Gear
- 2 — 2nd Gear
- 3 — 3rd Gear
- 4 — 4th Gear
- 5 — 5th Gear
- 6 — 6th Gear
- 7 — 7th Gear

**KEY**

- E — Empty Operating Weight 274 415 kg (604,980 lb)
- L — Target GMW 623 690 kg (1,375,000 lb)

\*At Sea Level.

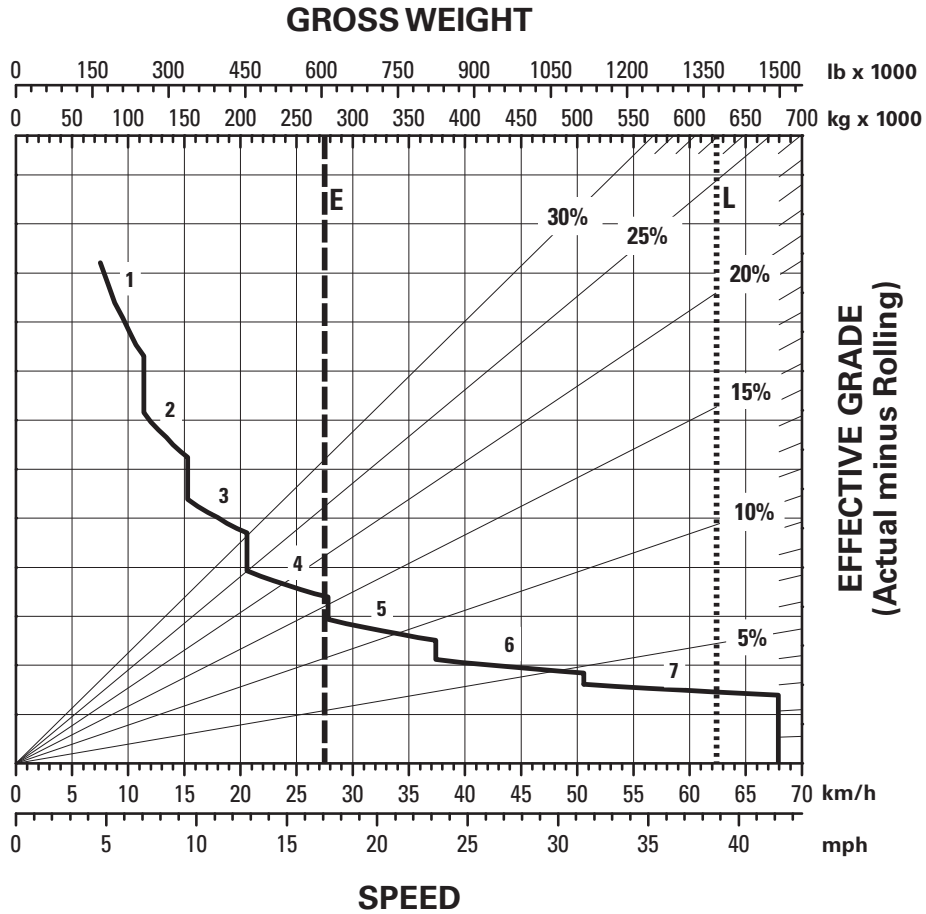

**KEY**

- 1 – 1st Gear
- 2 – 2nd Gear
- 3 – 3rd Gear
- 4 – 4th Gear
- 5 – 5th Gear
- 6 – 6th Gear
- 7 – 7th Gear

**KEY**

- E – Empty Operating Weight 274 415 kg (604,980 lb)
- L – Target GMW 623 690 kg (1,375,000 lb)

\*At Sea Level.

# Mining & Off-Highway Trucks

## 797F Brake Performance

- 450 m (1500 ft)
- 600 m (2000 ft)
- 900 m (3000 ft)
- 1500 m (5000 ft)

### GROSS WEIGHT

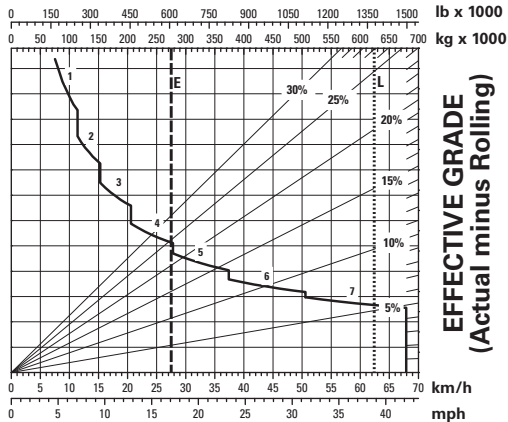

### SPEED

GRADE DISTANCE — 450 m (1500 ft)\*

### GROSS WEIGHT

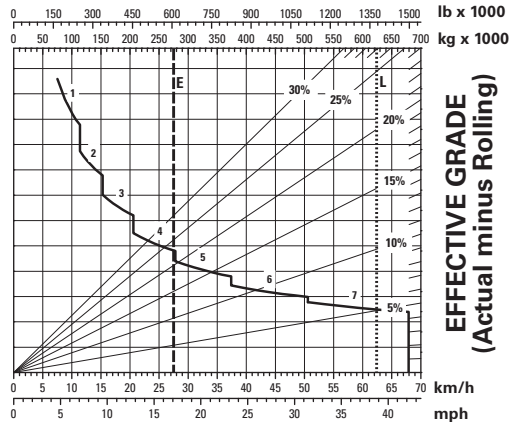

### SPEED

GRADE DISTANCE — 600 m (2000 ft)\*

### GROSS WEIGHT

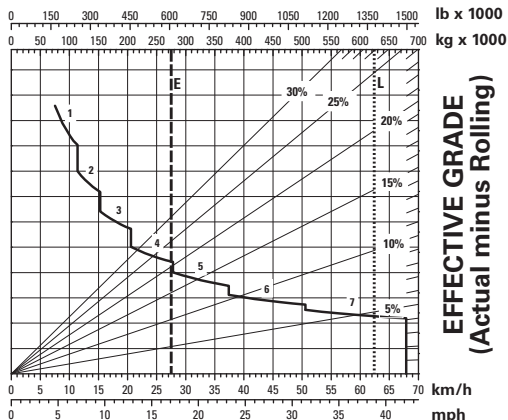

### SPEED

GRADE DISTANCE — 900 m (3000 ft)\*

### GROSS WEIGHT

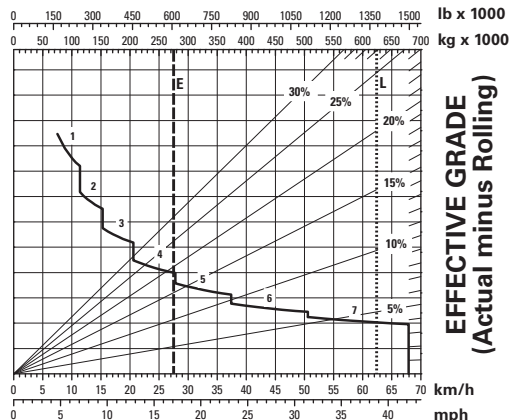

### SPEED

GRADE DISTANCE — 1500 m (5000 ft)\*

#### KEY

- 1 — 1st Gear
- 2 — 2nd Gear
- 3 — 3rd Gear
- 4 — 4th Gear
- 5 — 5th Gear
- 6 — 6th Gear
- 7 — 7th Gear

#### KEY

- E — Empty Operating Weight 274 415 kg (604,980 lb)
- L — Target GMW 623 690 kg (1,375,000 lb)

\*At Sea Level.

# MOTOR GRADERS

## CONTENTS

Industries Served . . . . .	11-1
Features . . . . .	11-2
Applications . . . . .	11-6
Truck to Motor Grader Match . . . . .	11-8
Specifications: Standard Versions . . . . .	11-9
Specifications: Global Versions . . . . .	11-12
Travel Speeds . . . . .	11-19
All Wheel Drive (AWD) . . . . .	11-21
Mid Mount and Front Mount Scarifiers . . . . .	11-21
Rear Ripper and Rear Ripper Scarifier . . . . .	11-22
Production . . . . .	11-27
Formulas . . . . .	11-29
Extreme Slope Operation . . . . .	11-30
Work Tools . . . . .	11-31

## INDUSTRIES SERVED

The motor grader is one of the most versatile work tools in the Cat® product line. The M Series machines are used in numerous applications within a wide range of industries. The major industries using Cat motor graders, along with the typical applications within each, are summarized below.

### ● Heavy Construction

- Highway Construction
- Paving/Resurfacing
- Airport Construction
- Railroad Construction
- Dam and Levee Construction
- Haul Road Maintenance

### ● Governmental

- Road Maintenance
- Road Construction
- Ditch Building/Cleaning
- Snow Removal

### ● Building Construction

- Residential Construction
- Commercial Construction
- Industrial Construction
- Sewer and Water Systems

### ● Industrial

- Waste Disposal
- Pipeline Construction

### ● Mining

- Haul Road Maintenance
- Snow Removal

### ● Forestry

- Access Road Construction
- Forest Development
- Snow Removal
- Haul Road Maintenance

- **Geographic Versions** — Cat motor graders were specifically designed to meet the needs of different geographic regions and regulations. K/K2 Series for less regulated locations and M/M2/M3 Series are available with an assortment of standard features and optional equipment. All motor graders feature advanced electronically controlled Cat engines, power train components, hydraulics and machine structures.

**FEATURES, M Series Motor Graders:**

Building on the strong heritage of the H Series, the M Series delivers multiple technological breakthroughs, setting the new standard for motor graders. The H Series has been the industry standard in a variety of heavy construction, mining, road building and governmental applications. The M Series continues this tradition, incorporating revolutionary, customer-driven enhancements by:

- Improving ease of operation and operation training time
- Offering best-in-class operator station and unmatched visibility
- Delivering maximum productivity
- Improving availability and decreasing maintenance time

The M Series line includes eleven models: 120, 120 AWD, 140, 140 AWD, 160, 160 AWD, 12, 12 AWD, 14, 16, 24. The 120 through 14 meet construction, road building, and governmental applications. The All Wheel Drive models improve traction in poor underfoot conditions such as snow, mud, and sand. The 16 and 24 meet the specialized needs of large mining customers.

- **Operation Station:** The 120 through 16 models feature a revolutionary cab design that provides unmatched comfort, visibility, storage and ease of use, which can enhance operator confidence and productivity. The interior noise level is maintained between 70 and 74 dB(A) with the doors and windows closed.

**Ease of Operation.** The revolutionary joystick controls and exceptional visibility make operating easier without sacrificing control. The intuitive joystick control pattern allows both new and experienced operators to become productive quickly. Logical grouping of hydraulic functions in the joysticks allow any operator to easily control several functions at the same time. This allows the operator to be more productive and remain comfortable throughout the work shift.

**Advanced Joystick Controls.** Two electro-hydraulic joysticks reduce hand and wrist movement as much as 78% compared to conventional lever controls for greatly enhanced operator efficiency. The intuitive pattern is easy to learn and provides the precise implement control to allow both new and experienced operators to become productive quickly. Logical grouping of hydraulic functions in the joysticks allow any operator to control several functions at the same time for more productivity.

**Visibility.** The 120 through 16 models boast excellent visibility to the work area, made possible with angled cab doors, a tapered engine enclosure and a patented sloped rear window. Ample glass area and carefully placed components provide excellent visibility to enhance operator confidence and productivity in all motor grader applications. The cab design gives the operator an exceptional view forward to the blade, working surface and front tires. The black glare-reducing paint on the front frame and engine enclosure enhances visibility.

- **Drawbar, Circle and Moldboard:** The 120 through 16 models provide a broad range of extended blade positions particularly beneficial in mid-range bank sloping, ditch cutting and ditch cleaning. A long wheel base allows for an aggressive blade angle permitting material to roll more freely, reducing power requirements. Top-accessible drawbar wear inserts and the shimless moldboard retention system make DCM adjustments fast and simple, delivering more precise material control while lowering operating costs.

**Top-Adjust Drawbar Wear Strips.** The patented top-adjust wear strips dramatically reduce drawbar/circle adjustment time. By removing the access plates on top of the drawbar, shims and wear strips can easily be added or replaced. This feature reduces service downtime and lowers overall machine operating costs.

**Shimless Moldboard Retention System.** The unique shimless moldboard retention system reduces the potential for blade chatter. Adjusting screws keep the moldboard's wear strips aligned for precise blade control and dramatic reductions in service time.

- **Power Train:** Integrated, electronically controlled systems, deliver smooth reliable performance with reduced operating costs.

**Smooth Shifting Transmission.** The transmission design combines several key innovations to ensure smooth, powerful shifts throughout the gear range.

**Advanced Productivity Electronics Control Strategy (APECS).** APECS utilizes an electronic control strategy to read the input from sensors to shift the transmission at the optimal point. Event based shifting allows operators to experience faster, smoother and more consistent shifts. Note: M Series 3 Only.

**Electronically Controlled Shifting.** The full Electronic Clutch Pressure Control (ECPC) system optimizes inching modulation and smoothes shifting between all gears and directional changes. This provides outstanding control and also extends the life of the transmission by reducing stress on gears.

**Load Compensation.** This standard feature ensures consistent shift quality regardless of blade or machine load.

**Hydraulic Brakes.** The oil bathed, multi-disc service brakes are hydraulically actuated, providing smooth predictable braking and lower operating costs. With brakes located at each tandem wheel, the Cat motor graders offer the largest total brake surface area in the industry, delivering dependable stopping power and longer brake life.

- **Engine:** The Cat motor grader combines power management with ACERT™ Technology to deliver maximum power and efficiency while reducing the environmental impact.

**ACERT Technology.** ACERT Technology allows Cat engines to supply more power per unit of displacement without causing premature wear. This breakthrough technology reduces emissions during the combustion process by using advanced technology in the air and fuel systems, in conjunction with integrated electronics. ACERT Technology enhances overall engine performance while dramatically reducing exhaust emissions.

**Power Management.** Power Management utilizes Variable Horse Power (VHP) and Variable Horse Power Plus (VHP Plus) to optimize motor grader performance. VHP delivers additional power in the working gear while balancing fuel consumption, traction and horsepower. VHP Plus, delivers additional power in each forward gear 5th through 8th for increased speed on grade and performance.

**Exhaust Emission Standards.** The Cat ACERT Technology engines in the M Series Motor Graders meet U.S. EPA Tier 3/EU Stage IIIA equivalent/Japan 2006 (Tier 3) emission standards. The M Series 2 machines meet U.S. EPA Tier 4 Interim/EU Stage IIIB/Japan 2011 (Tier 4 Interim) equivalent emission standards. The M Series 3 machines meet U.S. EPA Tier 4 Final/EU Stage IV/Japan 2014 (Tier 4 Final) emission standards.

- **Hydraulics:** Electro-hydraulics enable advanced machine controls with precise and predictable movements.

**Advanced Electro-Hydraulic System.** The Cat motor grader product line incorporates a state-of-the-art electro-hydraulic system. This technology is the foundation for revolutionary changes of the machine and implement controls. Advanced joystick controls provide unmatched controllability with precise, predictable hydraulic movements and the reliability you expect from Cat products.

**Load Sensing Hydraulics (PPPC).** The time proven load-sensing system and the advanced Proportional Priority Pressure-Compensating (PPPC, or “triple-PC”) electro-hydraulic valves are designed to provide superior implement control and enhanced machine performance in all applications. Continuous matching of hydraulic flow and pressure to power demands creates less heat and reduces power consumption.



- **Serviceability:**

**Grouped Service Points.** Grouped daily service points in the left side service center help ensure proper maintenance and inspection routines.

**Extended Service Intervals.** Extended service intervals, such as 500-hour engine oil changes and 4000-hour hydraulic oil changes, reduce machine service time and increase availability.

**Ecology Drains.** Conveniently located ecology drains shorten service times and help keep the environment safe by preventing spills.

**Diagnostics and Monitoring.** Cat Messenger and Cat Message are offered as standard equipment to enhance diagnostic capabilities by displaying machine system errors and fault codes. Cat Electronic Technician is a two way communication tool that provides easy access to stored diagnostic data and lets technicians configure machine parameters through the Cat Data Link. Product Link™ provides a communication flow of vital machine data and location. Cat motor graders integrate Cat Messenger, Cat Electronic Technician, and S•O•S<sup>SM</sup> analysis for easy monitoring and fast troubleshooting, keeping your machine up and running. Note: Cat Messenger is standard on M Series and M Series 2 only. Cat Message is standard on M Series 3 only.

- **Safety.** Safety is an integral part of all machine and system designs. Cat motor graders provide a safe working environment for both the operator and ground personnel. ROPS and FOPS structures meeting current SAE and ISO requirements are standard on all Global machines. Back-up alarms are a standard feature.

**Operator Presence System.** The Operator Presence System keeps the parking brake engaged until the operator is seated for safe operation.

**Secondary Steering System.** The standard secondary steering system automatically engages in case of a drop in steering pressure, allowing the operator to steer the machine to a stop.

**Speed Sensitive Steering.** The steering software automatically provides an infinitely variable ratio between the joystick and the steer tires, resulting in less sensitive steering as the groundspeed increases.

**Hydraulic Lockout.** A simple switch located in the cab disables all implement functions while still providing machine steering control. This safety feature is especially useful while the machine is roading.

**Circle Drive Slip Clutch.** This standard feature protects the drawbar, circle and moldboard from shock loads when the end of the blade encounters immovable objects. It also reduces the possibility of abrupt directional changes in poor traction conditions, protecting the machine, operator and surroundings.

**Blade Lift Accumulators.** This optional feature uses accumulators to help absorb impact loads to the moldboard by allowing vertical blade travel. Blade lift accumulators reduce unnecessary wear and help to avoid unintended machine movement for increased operator safety.

**Drop-Down Rear Lights.** Optional drop-down lights fold out from the rear of the machine. This creates a wider, lower profile, to be better aligned with passenger cars.

**Rearview Camera.** Visibility is further enhanced with an optional Work Area Vision System (WAVS) LCD color monitor in the cab.

- **Automatic Differential Lock/Unlock.** The Auto Diff-Lock feature automatically unlocks the differential during a turn, re-locks when straight, for easier operation and improved power train protection.
- **Swing Out Cooling Fan.** This standard feature allows for easy access to the cooling cores reducing time required for clean out. The latched door requires no tools for opening and closing. Note: M Series 2 and M Series 3 Only.

## FEATURES, K Series Motor Graders:

### Overview

The K Series model line-up is targeted to meet customer requirements in less regulated countries. Built on the success of the Standard H Series, the K Series delivers multiple improvements in emissions control and operator features, while still maintaining the industry standard for reliability. The K Series model line up consists of the 120K, 120K2, 12K, 140K, 140K2, and 160K.

### Engine

- **ACERT Engine Technology:** Cat ACERT engine technology utilizes numerous advanced components to efficiently produce more power and reduce emissions.
- **Emissions:** The K Series Motor Graders meet U.S. EPA Tier 2/EU Stage II equivalent emission standards. The K Series 2 machines are certified to Bharat Stage III and China Stage II emission standards.
- **Power Management Strategy:** The K Series power management strategy provides an additional 7.5 kW (10 hp) increase in third and another 7.5 kW (10 hp) in fourth gear through Variable Horsepower (VHP). This allows the operator to maintain maximum rim-pull while increasing ground speed and productivity.

### Power Train

- **Electronic Clutch Pressure Control (ECPC):** This standard feature smoothes shifts and improves inching control. The system uses input from the transmission and operator controls to modulate the directional clutches and produce consistent shifting.
- **Autoshift:** This optional feature improves ease of operation and maximizes productivity by automatically shifting the transmission at optimal shifting points.

### Serviceability

- **Grouped Service Points:** Grouped daily service points in the left side service center help ensure proper maintenance and inspection routines.
- **Diagnostic Capability:** The improved dash cluster keeps the operator informed of critical system conditions. Cat Electronic Technician is also offered, allowing faster diagnostic capabilities by service personnel. Product Link allows tracking of vital machine data and location, providing a convenient way to track the machine.
- **Extended Service Intervals:** Improvements in serviceability allow increased machine operation between service intervals. The machines can operate a full 500 hours between engine oil and filter changes, 4,000 hours between hydraulic oil changes, and 12,000 hours between engine coolant changes. This reduces downtime and operating expense.

**APPLICATIONS, Motor Graders:**

The broad line of Cat motor graders allows the customer to choose a motor grader that best fits the intended application. Below is a summary of the typical motor grader applications.

**Finish Grading**

This application involves preparing a roadway or site surface for future paving or other construction activity. The material being moved is usually a hard, dry base material on a solid underfoot. Finish blading is the motor grader application that requires the highest degree of accuracy. Thus, it is primarily done at low operating speeds — usually less than 5 km/h (3 mph) — in gears 1 and 2. To ensure a smooth, even finished surface, one gear is usually maintained for a given pass. Pass lengths during this application are usually less than 600 m (2000 feet) for road construction and 150 m (500 feet) for site development. Most finish blading is performed by contractors in the Heavy Construction and Building Construction industries.

**Heavy Blading**

This application involves cutting, moving, and mixing material, usually in the initial stages of surface preparation. A variety of material types are moved in this manner, and the blade tip position varies accordingly. Full blade loads are usually experienced during heavy blading, since moving material is the primary goal. Pass lengths within this application vary, but are usually less than 600 m (2000 feet). Unlike finish blading, the speed of the machine is dependent on the load being moved when heavy blading material. Typical operating speeds are from 0-10 km/h (0 to 6 mph). Therefore, gears 2 through 4 are frequently used in this application. Most heavy blading activity is performed by contractors in the Heavy Construction, Governmental, Industrial, and Forestry industries.

**Site Preparation**

This application involves any material cutting, moving, and mixing necessary to prepare a residential, commercial, or industrial site for construction. A variety of materials are encountered in this application. Blade loads vary depending on the activity being performed. Both heavy blading and finish blading are performed when preparing a site. Pass lengths are typically in the range of 30-300 m (100 to 1000 feet). Typical operating speeds for site preparation vary depending on whether heavy blading or finish blading activities are being performed. Most site preparation activities are performed by contractors in the Building Construction industry.

**Road Maintenance**

This application involves reshaping dirt or gravel roads to maintain a crown or superelevation, or restoring the surface itself. This generally involves secondary roads maintained by governmental bodies such as townships and counties. Materials being moved in this application vary from extremely hard dirt bases to moist gravel surfaces. The typical blade load falls between that of finish blading and heavy blading. Pass lengths are frequently longer than 600 m (2000 feet) and can extend for miles. The general speed range for this application is 5-16 km/h (3 to 10 mph), corresponding to gears 2 (heavy dirt) through 5 (soft gravel). As with finish blading, accuracy of the graded surface is the primary concern in this application. Thus, frequent shifts should be avoided whenever possible. A gear should be chosen and maintained unless there is a significant change in the material being moved. Most road maintenance activities are performed by the Governmental industry.

### Haul Road Maintenance

This application of the motor grader involves reshaping haul roads at mining, construction, or forestry work sites, usually for the purpose of maintaining smooth travel surfaces for equipment. Materials being moved while maintaining haul roads vary widely. Typical blade loads are about one-third to half of full capacity. Haul roads that experience large hauling units travelling on soft material may require heavy blade loads in order to reshape the road surface. Pass lengths vary depending on the application but can extend for miles on remote forestry or large mine haul roads. The general speed range for haul road maintenance is heavily dependent on the material being moved as well as the grade of the haul road. Many mine sites are in mountainous areas, requiring haul roads with steep grades. Generally, haul-road maintenance is performed at speeds similar to those required for general road maintenance 5-16 km/h (3 to 10 mph).

A travel surface that allows for the safe and efficient movement of machinery is the ultimate goal with this motor grader application. Very precise roadway elevations and slopes are desired but less crucial than when finish blading. Most haul road maintenance activities are performed by the Mining, Heavy Construction, and Forestry industries.

### Side/Bank Slope Work

This application involves preparing side slopes or bank slopes along roadways by placing the moldboard on a sloped surface. Slopes of up to a 2:1 angle can be cut using a motor grader. Often the motor grader is operated on the level surface adjacent to the slope, and the moldboard is extended outward to the sloped surface. Fine soils are generally encountered in this application of the motor grader. Blade loads are usually less than half of the full blade capacity, and pass lengths are seldom longer than 600 m (2000 feet). A smooth-graded sloped surface is the primary concern in this application so frequent shifts should be avoided. The typical speed range is 0-6 km/h (0 to 4 mph), corresponding to a gear selection of 1 to 3. The nominal speed is heavily dependent on the type of material being moved and on the slope of the surface. Most side/bank slope work is performed by the Heavy Construction and Governmental industries.

### Ditch Building/Cleaning

This application involves cutting “V” and flat-bottom ditches for drainage purposes and rebuilding them when necessary. Due to excessive rain and/or poor material, ditches often need cleaning and reshaping. When building ditches, materials with a wide range of densities are encountered. Blade loads vary accordingly, from half to full-blade capacity. Pass lengths are usually less than 600 m (2000 feet). The primary objective is to move material in a manner that yields a ditch with the desired slope. Ditch building often involves cutting and moving material of high density. Therefore, typical speed ranges vary. Most ditch building work, however, is performed in gears 1 through 3, corresponding to a maximum speed of about 8 km/h (5 mph). Ditch cleaning usually involves blading moist materials underneath a sod cover. Blade loads are usually less than half of full blade capacity when cleaning ditches, and pass lengths are similar to those encountered in ditch building. Typical maximum speeds for this activity are similar to that of ditch building, but less of a blade load is experienced. Ditch building and cleaning activities are usually performed by the Heavy Construction and Governmental industries.

















**Ripping/Scarifying**

This application involves conditioning hard, rough soils before they are bladed. Shanks on the ripper and/or scarifier are pushed into the ground, thus breaking up otherwise hard surfaces. Hard materials such as asphalt can also be loosened in order to make grading operations less damaging to the moldboard. Rippers and scarifiers can also be used to mix aggregates together. The materials being ripped/ scarified are usually hard and dry. Rippers generally penetrate 150-300 mm (6 to 12 inches) into the ground, while scarifiers typically penetrate to a depth of 25-200 mm (1 to 8 inches). Pass lengths are generally less than 600 m (2000 feet) for both activities. Since the material being ripped/scarified is generally hard, the typical maximum speed for this application is about 6 km/h (4 mph) gears 1-2. If the ripper/scarifier is used for mixing aggregates, the typical operating range becomes 6-20 km/h (4 to 12 mph) gears 3-6. Most ripping/scarifying activities are performed by the Heavy Construction and Governmental industries.

**Snow Removal**

Snow removal is the process of cutting and removing snow or ice from the roadway. In addition to the standard motor grader moldboard, other attachments such as a snow wing, V-plow, one-way plow, or reversible plow can be used to remove the snow. The moldboard itself is the most commonly used attachment for snow plowing. It is used in areas where snow depths are low, the terrain is relatively flat, and where excessive drifting does not occur. A snow wing is a moldboard that attaches to the machine's right side. The wing's curvature lifts the snow and "wings" it off the plowed surface. The snow wing is often used in conjunction with the standard moldboard, where the moldboard cuts the material and feeds it onto the wing. V-plows are mounted in front of the motor grader and are designed to dig into and lift packed snow. The typical speed range for snow removal is 10-30 km/h (6 to 18 mph), corresponding to a gear range of 3 to 7. Snow plowing often involves lower speeds than snow removal. The typical operating range for snow plowing is 8-19 km/h (5 to 12 mph) gears 2 to 4. The majority of Snow Removal/Plowing operations are performed by the Governmental, Mining, and Forestry industries.

**TRUCK TO MOTOR GRADER MATCH**

	740	770	775	777	785	789	793	797
12/140/160								
14								
16								
18								
24								

**NOTE:** Calculations based on 30 degree blade angle, standard moldboard width.  
 May not be applicable in all applications depending on haul road damage.  
 Rule of thumb 2.5 times the truck width.

MODEL	120K		12K	
Net Flywheel Power: Gears 4-8	108 kW	145 hp	123 kW	165 hp
Gear 3▲	101 kW	135 hp	116 kW	156 hp
Gears 1-2▲	93 kW	125 hp	108 kW	145 hp
Operating Weight (Typical)*	13 843 kg	30,519 lb	14 308 kg	31,543 lb
Engine Model	C7 ACERT VHP		C7 ACERT VHP	
Rated Engine RPM	2000		2000	
No. of Cylinders	6		6	
Displacement	7.2 L	439 in <sup>3</sup>	7.2 L	439 in <sup>3</sup>
Max. Torque	774 N·m	571 lb-ft	881 N·m	650 lb-ft
No. of Speeds Forward/Reverse	8/6		8/6	
Top Speed: Forward	47.5 km/h	29.5 mph	46.8 km/h	29.0 mph
Reverse	37.5 km/h	23.3 mph	36.8 km/h	22.9 mph
Std. Tires — Front and Rear	13.00-24 (12 PR) (G-2)		13.00-24 (12 PR) (G-2)	
Front Axle/Steering:				
Oscillation Angle	32°		32°	
Wheel Lean Angle	18°		18°	
Steering Angle	47.5°		47.5°	
Articulation Angle	20°		20°	
Minimum Turning Radius**	7.3 m	23'11"	7.5 m	24'7"
Front Frame Section Modulus:				
Min.	1619 cm <sup>3</sup>	99 in <sup>3</sup>	2083 cm <sup>3</sup>	127 in <sup>3</sup>
Max.	3681 cm <sup>3</sup>	225 in <sup>3</sup>	4785 cm <sup>3</sup>	291 in <sup>3</sup>
No. Circle Support Shoes	4		6	
Hydraulics: Pump Type	Variable Piston		Variable Piston	
Max. Pump Flow	210 L/min	55.7 gpm	210 L/min	55.7 gpm
Reservoir Tank Capacity	55 L	14.5 U.S. gal	55 L	14.5 U.S. gal
Implement Pressure: Max.	25 500 kPa	3699 psi	25 500 kPa	3699 psi
Min.	3600 kPa	522 psi	3600 kPa	522 psi
Electrical:				
System Size	24V		24V	
Std. Battery CCA @ 0° F	750		750	
Std. Alternator	115 amp		115 amp	
GENERAL DIMENSIONS:				
Height (to top of ROPS)	3.33 m	10'11"	3.35 m	11'0"
Height (No Cab/Canopy)***	2.88 m	9'6"	3.05 m	10'0"
Overall Length	8.24 m	27'0"	8.50 m	27'11"
With Ripper and Pushplate	9.77 m	32'1"	10.01 m	32'10"
Wheelbase	5.87 m	19'3"	6.09 m	20'0"
Blade Base	2.60 m	8'6"	2.60 m	8'6"
Overall Width (at top of front tires)	2.46 m	8'1"	2.48 m	8'2"
Standard Blade: Length	3.66 m	12'0"	3.66 m	12'0"
Height	610 mm	2'0"	610 mm	2'0"
Thickness	22 mm	0.87"	22 mm	0.87"
Lift Above Ground	410 mm	16"	480 mm	18.9"
Max. Shoulder Reach:◀				
Frame Straight — Right	1.93 m	6'4"	1.81 m	5'11"
Frame Straight — Left	1.76 m	5'9"	1.86 m	6'1"
Fuel Tank Capacity	305 L	80.6 U.S. gal	305 L	80.6 U.S. gal

\*Typical Operating Weight — based on standard machine configuration, with Cab High Profile ROPS, 13.00-24 12 PR (G-2) tires, full fuel tank, coolant, lubricants and operator.

\*\*Minimum Turning Radius — combining the use of articulated frame steering, front wheel steer and unlocked differential.

\*\*\*Height (No Cab/Canopy) — without ROPS, exhaust, or other easily removed encumbrances.

◀ Applicable for the standard blade with hydraulic sideshift and tip control. Maximum shoulder reach is obtainable to the right.

▲ Engine Power Management automatically reduces power in gears 1F-3F and 1R-2R.

<b>MODEL</b>	<b>140K</b>		<b>160K</b>	
Net Flywheel Power: Gears 4-8	143 kW	<b>191 hp</b>	154 kW	<b>206 hp</b>
Gear 3▲	135 kW	<b>181 hp</b>	147 kW	<b>196 hp</b>
Gears 1-2▲	128 kW	<b>171 hp</b>	139 kW	<b>186 hp</b>
Operating Weight (Typical)*	15 108 kg	<b>33,307 lb</b>	15 873 kg	<b>34,994 lb</b>
Engine Model	<b>C7 ACERT VHP</b>		<b>C7 ACERT VHP</b>	
Rated Engine RPM	<b>2000</b>		<b>2000</b>	
No. of Cylinders	<b>6</b>		<b>6</b>	
Displacement	7.2 L	<b>439 in<sup>3</sup></b>	7.2 L	<b>439 in<sup>3</sup></b>
Max. Torque	996 N·m	<b>735 lb-ft</b>	1076 N·m	<b>794 lb-ft</b>
No. of Speeds Forward/Reverse	<b>8/6</b>		<b>8/6</b>	
Top Speed: Forward	47.3 km/h	<b>29.4 mph</b>	46.9 km/h	<b>29.1 mph</b>
Reverse	37.4 km/h	<b>23.2 mph</b>	37.0 km/h	<b>23.0 mph</b>
Std. Tires — Front and Rear	<b>14.00-24 (12 PR) (G-2)</b>		<b>14.00-24 (12 PR) (G-2)</b>	
Front Axle/Steering:				
Oscillation Angle	<b>32°</b>		<b>32°</b>	
Wheel Lean Angle	<b>18°</b>		<b>18°</b>	
Steering Angle	<b>47.5°</b>		<b>47.5°</b>	
Articulation Angle	<b>20°</b>		<b>20°</b>	
Minimum Turning Radius**	7.5 m	<b>24'7"</b>	7.5 m	<b>24'7"</b>
Front Frame Section Modulus:				
Min.	2083 cm <sup>3</sup>	<b>127 in<sup>3</sup></b>	2083 cm <sup>3</sup>	<b>127 in<sup>3</sup></b>
Max.	4785 cm <sup>3</sup>	<b>291 in<sup>3</sup></b>	4785 cm <sup>3</sup>	<b>291 in<sup>3</sup></b>
No. Circle Support Shoes	<b>6</b>		<b>6</b>	
Hydraulics: Pump Type	<b>Variable Piston</b>		<b>Variable Piston</b>	
Max. Pump Flow	210 L/min	<b>55.7 gpm</b>	210 L/min	<b>55.7 gpm</b>
Reservoir Tank Capacity	55 L	<b>14.5 U.S. gal</b>	55 L	<b>14.5 U.S. gal</b>
Implement Pressure: Max.	25 500 kPa	<b>3699 psi</b>	25 500 kPa	<b>3699 psi</b>
Min.	3600 kPa	<b>522 psi</b>	3600 kPa	<b>522 psi</b>
Electrical:				
System Size	<b>24V</b>		<b>24V</b>	
Std. Battery CCA @ 0° F	<b>750</b>		<b>750</b>	
Std. Alternator	<b>115 amp</b>		<b>115 amp</b>	
GENERAL DIMENSIONS:				
Height (to top of ROPS)	3.35 m	<b>11'0"</b>	3.35 m	<b>11'0"</b>
Height (No Cab/Canopy)***	3.05 m	<b>10'0"</b>	3.05 m	<b>10'0"</b>
Overall Length	8.50 m	<b>27'11"</b>	8.50 m	<b>27'11"</b>
With Ripper and Pushplate	10.01 m	<b>32'10"</b>	10.01 m	<b>32'10"</b>
Wheelbase	6.09 m	<b>20'0"</b>	6.09 m	<b>20'0"</b>
Blade Base	2.60 m	<b>8'6"</b>	2.60 m	<b>8'6"</b>
Overall Width (at top of front tires)	2.48 m	<b>8'2"</b>	2.48 m	<b>8'2"</b>
Standard Blade: Length	3.66 m	<b>12'0"</b>	4.27 m	<b>14'0"</b>
Height	610 mm	<b>2'0"</b>	686 mm	<b>2'3"</b>
Thickness	22 mm	<b>0.87"</b>	25 mm	<b>1"</b>
Lift Above Ground	480 mm	<b>18.9"</b>	452 mm	<b>17.8"</b>
Max. Shoulder Reach:◄				
Frame Straight — Right	1.98 m	<b>6'6"</b>	2.26 m	<b>7'5"</b>
Frame Straight — Left	1.90 m	<b>6'3"</b>	2.22 m	<b>7'4"</b>
Fuel Tank Capacity	305 L	<b>80.6 U.S. gal</b>	344 L	<b>90.9 U.S. gal</b>

\***Typical Operating Weight** — based on standard machine configuration, with Cab High Profile ROPS, 14.00-24 12 PR (G-2) tires, full fuel tank, coolant, lubricants and operator.

\*\***Minimum Turning Radius** — combining the use of articulated frame steering, front wheel steer and unlocked differential.

\*\*\***Height (No Cab/Canopy)** — without ROPS, exhaust, or other easily removed encumbrances.

◄ Applicable for the standard blade with hydraulic sideshift and tip control. Maximum shoulder reach is obtainable to the right.

▲ Engine Power Management automatically reduces power in gears 1F-3F and 1R-2R.

MODEL	120K2		140K2	
Net Flywheel Power: Gears 4-8	108 kW	145 hp	143 kW	191 hp
Gear 3▲	101 kW	135 hp	135 kW	181 hp
Gears 1-2▲	93 kW	125 hp	128 kW	171 hp
Operating Weight (Typical)*	13 843 kg	30,519 lb	15 108 kg	33,307 lb
Engine Model	C7 ACERT VHP		C7 ACERT VHP	
Rated Engine RPM	2000		2000	
No. of Cylinders	6		6	
Displacement	7.2 L	439 in <sup>3</sup>	7.2 L	439 in <sup>3</sup>
Max. Torque	774 N·m	571 lb-ft	996 N·m	735 lb-ft
No. of Speeds Forward/Reverse	8/6		8/6	
Top Speed: Forward	47.5 km/h	29.5 mph	47.3 km/h	29.4 mph
Reverse	37.5 km/h	23.3 mph	37.4 km/h	23.2 mph
Std. Tires — Front and Rear	14.00-24 12 PR (G-2)		14.00 24 (10 PR) (G-2)	
Front Axle/Steering:				
Oscillation Angle	32°		32°	
Wheel Lean Angle	18°		18°	
Steering Angle	47.5°		47.5°	
Articulation Angle	20°		20°	
Minimum Turning Radius**	7.3 m	23'11"	7.5 m	24'7"
Front Frame Section Modulus:				
Min.	1619 cm <sup>3</sup>	99 in <sup>3</sup>	2083 cm <sup>3</sup>	127 in <sup>3</sup>
Max.	3681 cm <sup>3</sup>	225 in <sup>3</sup>	4785 cm <sup>3</sup>	291 in <sup>3</sup>
No. Circle Support Shoes	4		6	
Hydraulics: Pump Type	Variable Piston		Variable Piston	
Max. Pump Flow	210 L/min	55.7 gpm	210 L/min	55.7 gpm
Reservoir Tank Capacity	55 L	14.5 U.S. gal	55 L	14.5 gal
Implement Pressure: Max.	25 500 kPa	3699 psi	25 500 kPa	3699 psi
Min.	3600 kPa	522 psi	3600 kPa	522 psi
Electrical:				
System Size	24V		24V	
Std. Battery CCA @ 0° F	750		750	
Std. Alternator	115 amp		115 amp	
GENERAL DIMENSIONS:				
Height (to top of ROPS)	3.33 m	10'11"	3.35 m	11'0"
Height (No Cab/Canopy)***	2.88 m	9'6"	3.05 m	10'0"
Overall Length	8.24 m	27'0"	8.50 m	27'11"
With Ripper and Pushplate	9.77 m	32'1"	10.01 m	32'10"
Wheelbase	5.87 m	19'3"	6.09 m	20'0"
Blade Base	2.60 m	8'6"	2.60 m	8'6"
Overall Width (at top of front tires)	2.46 m	8'1"	2.48 m	8'2"
Standard Blade: Length	3.66 m	12'0"	3.66 m	12'0"
Height	610 mm	2'0"	610 mm	2'0"
Thickness	22 mm	0.87"	22 mm	0.87"
Lift Above Ground	410 mm	16"	480 mm	18.9"
Max. Shoulder Reach:◀				
Frame Straight — Right	1.93 m	6'4"	1.98 m	6'6"
Frame Straight — Left	1.76 m	5'9"	1.90 m	6'3"
Fuel Tank Capacity	305 L	80.6 U.S. gal	305 L	80.6 U.S. gal

\*Typical Operating Weight — based on standard machine configuration, with Cab High Profile ROPS, 14.00-24 12 PR (G-2) tires, full fuel tank, coolant, lubricants and operator.

\*\*Minimum Turning Radius — combining the use of articulated frame steering, front wheel steer and unlocked differential.

\*\*\*Height (No Cab/Canopy) — without ROPS, exhaust, or other easily removed encumbrances.

◀ Applicable for the standard blade with hydraulic sideshift and tip control. Maximum shoulder reach is obtainable to the right.

▲ Engine Power Management automatically reduces power in gears 1F-3F and 1R-2R.



<b>MODEL</b>	<b>120M</b>		<b>12M</b>	
Base Power — Net	103 kW	<b>138 hp</b>	136 kW	<b>183 hp</b>
VHP Range — Net	103-114 kW	<b>138-153 hp</b>	136-144 kW	<b>183-193 hp</b>
VHP Plus Range — Net	103-136 kW	<b>138-182 hp</b>	136-159 kW	<b>183-213 hp</b>
Operating Weight*	14 493 kg	<b>31,951 lb</b>	16 231 kg	<b>35,783 lb</b>
Engine Model	<b>C6.6 ACERT</b>		<b>C7 ACERT</b>	
Rated Engine RPM	<b>2000</b>		<b>2000</b>	
No. of Cylinders	<b>6</b>		<b>6</b>	
Displacement	6.6 L	<b>403 in<sup>3</sup></b>	7.2 L	<b>439 in<sup>3</sup></b>
Max. Torque	906 N·m	<b>668 lb-ft</b>	1052 N·m	<b>776 lb-ft</b>
No. of Speeds Forward/Reverse	<b>8/6</b>		<b>8/6</b>	
Top Speed: Forward	47.5 km/h	<b>29.5 mph</b>	46.6 km/h	<b>29.0 mph</b>
Reverse	37.5 km/h	<b>23.3 mph</b>	36.8 km/h	<b>22.9 mph</b>
Std. Tires — Front and Rear	<b>14.00 24 (12 PR) (G-2)</b>		<b>14.00 24 (10 PR) (G-2)</b>	
Front Axle/Steering:				
Oscillation Angle	<b>32°</b>		<b>32°</b>	
Wheel Lean Angle	<b>18.0°</b>		<b>18.0°</b>	
Steering Angle	<b>47.5°</b>		<b>47.5°</b>	
Articulation Angle	<b>20°</b>		<b>20°</b>	
Minimum Turning Radius**	7.3 m	<b>24'1"</b>	7.6 m	<b>24'10"</b>
No. Circle Support Shoes	<b>4</b>		<b>6</b>	
Hydraulics:				
Pump Type	<b>Variable Piston</b>		<b>Variable Piston</b>	
Max. Pump Flow	210 L	<b>55.7 gpm</b>	210 L/min	<b>55.7 gpm</b>
Tank Capacity	64 L	<b>16.9 U.S. gal</b>	64 L	<b>16.9 U.S. gal</b>
Implement Pressure: Max.	24 150 kPa	<b>3500 psi</b>	24 150 kPa	<b>3500 psi</b>
Min.	3100 kPa	<b>450 psi</b>	3100 kPa	<b>450 psi</b>
Interior Sound Level/SAE J919	<b>70 dB(A)</b>		<b>70 dB(A)</b>	
Electrical:				
System Size	<b>24V</b>		<b>24V</b>	
Std. Battery CCA @ 0° F	<b>1125</b>		<b>1125</b>	
Std. Alternator	<b>80</b>		<b>80</b>	
GENERAL DIMENSIONS:				
Height (to top of ROPS)	3308 mm	<b>130.2"</b>	3308 mm	<b>130.2"</b>
Overall Length	8436 mm	<b>332.1"</b>	8754 mm	<b>344.6"</b>
With Ripper and Pushplate	9930 mm	<b>390.9"</b>	10 136 mm	<b>399.1"</b>
Wheelbase	5915 mm	<b>233.0"</b>	6123 mm	<b>241.1"</b>
Blade Base	2511 mm	<b>98.9"</b>	2511 mm	<b>98.9"</b>
Overall Width (at top of front tires)	2491 mm	<b>98.1"</b>	2511 mm	<b>98.9"</b>
Standard Blade: Length	3658 mm	<b>12'0"</b>	3658 mm	<b>12'0"</b>
Height	610 mm	<b>24.0"</b>	610 mm	<b>24.0"</b>
Thickness	22 mm	<b>0.87"</b>	22 mm	<b>0.87"</b>
Lift Above Ground	427 mm	<b>16.8"</b>	480 mm	<b>18.9"</b>
Max. Shoulder Reach:***				
Frame Straight — Left	1742 mm	<b>68.6"</b>	1790 mm	<b>70.5"</b>
Frame Straight — Right	1905 mm	<b>75"</b>	1978 mm	<b>77.9"</b>
Fuel Tank Capacity	378 L	<b>100 U.S. gal</b>	416 L	<b>110 U.S. gal</b>

\*Operating Weight — based on standard machine configuration with full fuel tank, coolant, lubricants and operator.

\*\*Minimum Turning Radius — combining the use of articulated frame steering, front wheel steer and unlocked differential.

\*\*\*Applicable for the standard blade with hydraulic sideshift and tip control. Maximum shoulder reach is obtainable to the right.

MODEL	140M		160M	
Base Power — Net	136 kW	183 hp	159 kW	213 hp
VHP Range — Net	136-155 kW	183-208 hp	159-170 kW	213-228 hp
VHP Plus Range — Net	136-174 kW	183-233 hp	159-185 kW	213-248 hp
Operating Weight*	16 581 kg	36,554 lb	16 820 kg	37,082 lb
Engine Model	C7 ACERT/C9 ACERT (AWD)		C9 ACERT	
Rated Engine RPM	2000		2000	
No. of Cylinders	6		6	
Displacement	7.2 L/8.8 L	439 in <sup>3</sup> /537 in <sup>3</sup>	8.8 L	537 in <sup>3</sup>
Max. Torque	1159 N·m/1344 N·m	855 lb-ft/991 lb-ft	1237 N·m	912 lb-ft
No. of Speeds Forward/Reverse	8/6		8/6	
Top Speed: Forward	46.6 km/h	29.0 mph	47.4 km/h	29.5 mph
Reverse	36.8 km/h	22.9 mph	37.4 km/h	23.3 mph
Std. Tires — Front and Rear	14.00 24 (10 PR) (G-2)		14.00 24 (10 PR) (G-2)	
Front Axle/Steering:				
Oscillation Angle	32°		32°	
Wheel Lean Angle	18.0°		18.0°	
Steering Angle	47.5°		47.5°	
Articulation Angle	20°		20°	
Minimum Turning Radius**	7.6 m	24'10"	7.6 m	24'10"
No. Circle Support Shoes	6		6	
Hydraulics:				
Pump Type	Variable Piston		Variable Piston	
Max. Pump Flow	210 L/min	55.7 gpm	210 L/min	55.7 gpm
Tank Capacity	64 L	16.9 U.S. gal	64 L	16.9 U.S. gal
Implement Pressure: Max.	24 150 kPa	3500 psi	24 150 kPa	3500 psi
Min.	3100 kPa	450 psi	3100 kPa	450 psi
Interior Sound Level/SAE J919	70 dB(A)		70 dB(A)	
Electrical:				
System Size	24V		24V	
Std. Battery CCA @ 0° F	1125		1125	
Std. Alternator	80		80	
GENERAL DIMENSIONS:				
Height (to top of ROPS)	3308 mm	130.2"	3308 mm	130.2"
Overall Length	8754 mm	344.6"	8754 mm	344.6"
With Ripper and Pushplate	10 136 mm	399.1"	10 136 mm	399.1"
Wheelbase	6123 mm	241.1"	6123 mm	241.1"
Blade Base	2511 mm	98.9"	2511 mm	98.9"
Overall Width (at top of front tires)	2511 mm	98.9"	2511 mm	98.9"
Standard Blade: Length	3658 mm	12'0"	3658 mm	12'0"
Height	610 mm	24.0"	610 mm	24.0"
Thickness	22 mm	0.87"	22 mm	0.87"
Lift Above Ground	480 mm	18.9"	452 mm	17.8"
Max. Shoulder Reach:***				
Frame Straight — Left	1790 mm	70.5"	2090 mm	82.3"
Frame Straight — Right	1978 mm	77.9"	2278 mm	89.7"
Fuel Tank Capacity	416 L	110 U.S. gal	416 L	110 U.S. gal

\*Operating Weight — based on standard machine configuration with full fuel tank, coolant, lubricants and operator.

\*\*Minimum Turning Radius — combining the use of articulated frame steering, front wheel steer and unlocked differential.

\*\*\*Applicable for the standard blade with hydraulic sideshift and tip control. Maximum shoulder reach is obtainable to the right.

<b>MODEL</b>	<b>120M2</b>		<b>12M2</b>	
Base Power — Net	108 kW	<b>145 hp</b>	129 kW	<b>173 hp</b>
VHP Plus Range — Net	108-141 kW	<b>145-189 hp</b>	129-166 kW	<b>173-223 hp</b>
Operating Weight*	15 887 kg	<b>35,025 lb</b>	16 849 kg	<b>37,145 lb</b>
Engine Model	<b>C7.1 ACERT</b>		<b>C9.3 ACERT</b>	
Rated Engine RPM	<b>2100</b>		<b>2100</b>	
No. of Cylinders	<b>6</b>		<b>6</b>	
Displacement	7.01 L	<b>428 in<sup>3</sup></b>	9.3 L	<b>567 in<sup>3</sup></b>
Max. Torque	939 N·m	<b>693 lb·ft</b>	1138 N·m	<b>839 lb·ft</b>
No. of Speeds Forward/Reverse	<b>8/6</b>		<b>8/6</b>	
Top Speed: Forward	45.7 km/h	<b>28.4 mph</b>	46.6 km/h	<b>29.0 mph</b>
Reverse	36.1 km/h	<b>22.4 mph</b>	36.8 km/h	<b>22.9 mph</b>
Std. Tires — Front and Rear	<b>13.00 24 (12 PR) (G-2)</b>		<b>14.00R24 * (G-2)</b>	
Front Axle/Steering:				
Oscillation Angle	<b>32°</b>		<b>32°</b>	
Wheel Lean Angle	<b>18°</b>		<b>18°</b>	
Steering Angle	<b>47.5°</b>		<b>47.5°</b>	
Articulation Angle	<b>20°</b>		<b>20°</b>	
Minimum Turning Radius**	7.3 m	<b>24'1"</b>	7.6 m	<b>24'10"</b>
No. Circle Support Shoes	<b>6</b>		<b>6</b>	
Hydraulics:				
Pump Type	<b>Variable Piston</b>		<b>Variable Piston</b>	
Max. Pump Flow	210 L/min	<b>55.7 gpm</b>	210 L/min	<b>55.7 gpm</b>
Tank Capacity	64 L	<b>16.9 U.S. gal</b>	64 L	<b>16.9 U.S. gal</b>
Implement Pressure: Max.	24 150 kPa	<b>3500 psi</b>	24 150 kPa	<b>3500 psi</b>
Min.	4200 kPa	<b>609 psi</b>	4200 kPa	<b>609 psi</b>
Interior Sound Level/SAE J919	<b>71 dB(A)</b>		<b>71 dB(A)</b>	
Electrical:				
System Size	<b>24V</b>		<b>24V</b>	
Std. Battery CCA @ 0° F	<b>1125</b>		<b>1125</b>	
Std. Alternator	<b>150 amp</b>		<b>150 amp</b>	
GENERAL DIMENSIONS:				
Height (to top of ROPS)	3308 mm	<b>130.2"</b>	3308 mm	<b>130.2"</b>
Overall Length	8820 mm	<b>347.2"</b>	8912 mm	<b>350.9"</b>
With Ripper and Pushplate	10 032 mm	<b>395.0"</b>	10 136 mm	<b>399.1"</b>
Wheelbase	5917 mm	<b>233.0"</b>	6123 mm	<b>241.1"</b>
Blade Base	2510 mm	<b>98.8"</b>	2552 mm	<b>100.5"</b>
Overall Width (at top of front tires)	2511 mm	<b>98.9"</b>	2511 mm	<b>98.9"</b>
Standard Blade: Length	3658 mm	<b>12'0"</b>	3658 mm	<b>12'0"</b>
Height	610 mm	<b>24.0"</b>	610 mm	<b>24.0"</b>
Thickness	22 mm	<b>0.87"</b>	22 mm	<b>0.87"</b>
Lift Above Ground	427 mm	<b>16.8"</b>	480 mm	<b>18.9"</b>
Max. Shoulder Reach:***				
Frame Straight — Left	1742 mm	<b>68.6"</b>	1790 mm	<b>70.5"</b>
Frame Straight — Right	1905 mm	<b>75"</b>	1978 mm	<b>77.9"</b>
Fuel Tank Capacity	378 L	<b>100 U.S. gal</b>	416 L	<b>110 U.S. gal</b>

\***Operating Weight** — based on standard machine configuration with full fuel tank, coolant, lubricants and operator.

\*\***Minimum Turning Radius** — combining the use of articulated frame steering, front wheel steer and unlocked differential.

\*\*\*Applicable for the standard blade with hydraulic sideshift and tip control. Maximum shoulder reach is obtainable to the right.

<b>MODEL</b>	<b>140M2</b>		<b>160M2</b>	
Base Power — Net	144 kW	<b>193 hp</b>	159 kW	<b>213 hp</b>
VHP Plus Range — Net	144-181 kW	<b>193-243 hp</b>	159-196 kW	<b>213-263 hp</b>
Operating Weight*	17 198 kg	<b>37,916 lb</b>	17 438 kg	<b>38,443 lb</b>
Engine Model	<b>C9.3 ACERT</b>		<b>C9.3 ACERT</b>	
Rated Engine RPM	<b>2100</b>		<b>2100</b>	
No. of Cylinders	<b>6</b>		<b>6</b>	
Displacement	9.3 L	<b>567 in<sup>3</sup></b>	9.3 L	<b>567 in<sup>3</sup></b>
Max. Torque	1247 N·m	<b>920 lb-ft</b>	1355 N·m	<b>1000 lb-ft</b>
No. of Speeds Forward/Reverse	<b>8/6</b>		<b>8/6</b>	
Top Speed: Forward	46.6 km/h	<b>29.0 mph</b>	47.4 km/h	<b>29.5 mph</b>
Reverse	36.8 km/h	<b>22.9 mph</b>	37.4 km/h	<b>23.3 mph</b>
Std. Tires — Front and Rear	<b>14.00R24 ★ (G-2)</b>		<b>14.00R24 ★ (G-2)</b>	
Front Axle/Steering:				
Oscillation Angle	<b>32°</b>		<b>32°</b>	
Wheel Lean Angle	<b>18.0°</b>		<b>18.0°</b>	
Steering Angle	<b>47.5°</b>		<b>47.5°</b>	
Articulation Angle	<b>20°</b>		<b>20°</b>	
Minimum Turning Radius**	7.6 m	<b>24'10"</b>	7.6 m	<b>24'10"</b>
No. Circle Support Shoes	<b>6</b>		<b>6</b>	
Hydraulics:				
Pump Type	<b>Variable Piston</b>		<b>Variable Piston</b>	
Max. Pump Flow	210 L/min	<b>55.7 gpm</b>	210 L/min	<b>55.7 gpm</b>
Tank Capacity	64 L	<b>16.9 U.S. gal</b>	64 L	<b>16.9 U.S. gal</b>
Implement Pressure: Max.	24 150 kPa	<b>3500 psi</b>	24 150 kPa	<b>3500 psi</b>
Min.	4200 kPa	<b>609 psi</b>	4200 kPa	<b>609 psi</b>
Interior Sound Level/SAE J919	<b>71 dB(A)</b>		<b>71 dB(A)</b>	
Electrical:				
System Size	<b>24V</b>		<b>24V</b>	
Std. Battery CCA @ 0° F	<b>1125</b>		<b>1125</b>	
Std. Alternator	<b>150</b>		<b>150</b>	
GENERAL DIMENSIONS:				
Height (to top of ROPS)	3308 mm	<b>130.2"</b>	3308 mm	<b>130.2"</b>
Overall Length	8912 mm	<b>350.9"</b>	8912 mm	<b>350.9"</b>
With Ripper and Pushplate	10 136 mm	<b>399.1"</b>	10 136 mm	<b>399.1"</b>
Wheelbase	6123 mm	<b>241.1"</b>	6123 mm	<b>241.1"</b>
Blade Base	2552 mm	<b>100.5"</b>	2552 mm	<b>100.5"</b>
Overall Width (at top of front tires)	2511 mm	<b>98.9"</b>	2511 mm	<b>98.9"</b>
Standard Blade: Length	3658 mm	<b>12'0"</b>	4267 mm	<b>14'0"</b>
Height	610 mm	<b>24.0"</b>	610 mm	<b>24.0"</b>
Thickness	22 mm	<b>0.87"</b>	22 mm	<b>0.87"</b>
Lift Above Ground	480 mm	<b>18.9"</b>	452 mm	<b>17.8"</b>
Max. Shoulder Reach:***				
Frame Straight — Left	1790 mm	<b>70.5"</b>	2090 mm	<b>82.3"</b>
Frame Straight — Right	1978 mm	<b>77.9"</b>	2278 mm	<b>89.7"</b>
Fuel Tank Capacity	416 L	<b>110 U.S. gal</b>	416 L	<b>110 U.S. gal</b>

\***Operating Weight** — based on standard machine configuration with full fuel tank, coolant, lubricants and operator.

\*\***Minimum Turning Radius** — combining the use of articulated frame steering, front wheel steer and unlocked differential.

\*\*\*Applicable for the standard blade with hydraulic sideshift and tip control. Maximum shoulder reach is obtainable to the right.

<b>MODEL</b>	<b>12M3</b>		<b>140M3</b>		<b>160M3</b>	
Base Power — Net	133 kW	<b>179 hp</b>	149 kW	<b>200 hp</b>	165 kW	<b>221 hp</b>
VHP Plus Range — Net	133-172 kW	<b>179-231 hp</b>	149-188 kW	<b>200-252 hp</b>	165-203 kW	<b>221-272 hp</b>
Operating Weight (Typical)*	16 974 kg	<b>37,420 lb</b>	17 323 kg	<b>38,191 lb</b>	17 563 kg	<b>38,719 lb</b>
Engine Model	<b>C9.3 ACERT</b>		<b>C9.3 ACERT</b>		<b>C9.3 ACERT</b>	
Rated Engine RPM	<b>2000</b>		<b>2000</b>		<b>2000</b>	
No. of Cylinders	<b>6</b>		<b>6</b>		<b>6</b>	
Displacement	9.3 L	<b>567 in<sup>3</sup></b>	9.3 L	<b>567 in<sup>3</sup></b>	9.3 L	<b>567 in<sup>3</sup></b>
Max. Torque	1138 N·m	<b>840 lb-ft</b>	1247 N·m	<b>920 lb-ft</b>	1355 N·m	<b>1000 lb-ft</b>
No. of Speeds Forward/Reverse	<b>8/6</b>		<b>8/6</b>		<b>8/6</b>	
Top Speed: Forward	46.6 km/h	<b>29.0 mph</b>	46.6 km/h	<b>29.0 mph</b>	47.4 km/h	<b>29.5 mph</b>
Reverse	36.8 km/h	<b>23.0 mph</b>	36.8 km/h	<b>23.0 mph</b>	37.4 km/h	<b>23.3 mph</b>
Std. Tires — Front and Rear	<b>14.00R24 * (G-2)</b>		<b>14.00R24 * (G-2)</b>		<b>14.00R24 * (G-2)</b>	
Front Axle/Steering:						
Oscillation Angle	<b>32°</b>		<b>32°</b>		<b>32°</b>	
Wheel Lean Angle	<b>18.0°</b>		<b>18.0°</b>		<b>18.0°</b>	
Steering Angle	<b>47.5°</b>		<b>47.5°</b>		<b>47.5°</b>	
Articulation Angle	<b>20°</b>		<b>20°</b>		<b>20°</b>	
Minimum Turning Radius**	7.6 m	<b>24'10"</b>	7.6 m	<b>24'10"</b>	7.6 m	<b>24'10"</b>
No. Circle Support Shoes	<b>6</b>		<b>6</b>		<b>6</b>	
Hydraulics:						
Pump Type	<b>Variable Piston</b>		<b>Variable Piston</b>		<b>Variable Piston</b>	
Max. Pump Flow	210 L/min	<b>55.7 gpm</b>	210 L/min	<b>55.7 gpm</b>	210 L/min	<b>55.7 gpm</b>
Tank Capacity	64 L	<b>16.9 U.S. gal</b>	64 L	<b>16.9 U.S. gal</b>	64 L	<b>16.9 U.S. gal</b>
Implement Pressure: Max.	24 150 kPa	<b>3500 psi</b>	24 150 kPa	<b>3500 psi</b>	24 150 kPa	<b>3500 psi</b>
Min.	6100 kPa	<b>885 psi</b>	6100 kPa	<b>885 psi</b>	6100 kPa	<b>885 psi</b>
Interior Sound Level/SAE J919	<b>71 dB(A)</b>		<b>71 dB(A)</b>		<b>71 dB(A)</b>	
Electrical:						
System Size	<b>24V</b>		<b>24V</b>		<b>24V</b>	
Std. Battery CCA @ 0° F	<b>1125</b>		<b>1125</b>		<b>1125</b>	
Std. Alternator	<b>150</b>		<b>150</b>		<b>150</b>	
GENERAL DIMENSIONS:						
Height (to top of ROPS)	3308 mm	<b>130.2"</b>	3308 mm	<b>130.2"</b>	3308 mm	<b>130.2"</b>
Overall Length	8912 mm	<b>350.9"</b>	8912 mm	<b>350.9"</b>	8912 mm	<b>350.9"</b>
With Ripper and Pushplate	10 136 mm	<b>399.1"</b>	10 136 mm	<b>399.1"</b>	10 136 mm	<b>399.1"</b>
Wheelbase	6123 mm	<b>241.1"</b>	6123 mm	<b>241.1"</b>	6123 mm	<b>241.1"</b>
Blade Base	2552 mm	<b>100.5"</b>	2552 mm	<b>100.5"</b>	2552 mm	<b>100.5"</b>
Overall Width						
(at top of front tires)	2511 mm	<b>98.9"</b>	2511 mm	<b>98.9"</b>	2511 mm	<b>98.9"</b>
Standard Blade: Length	3658 mm	<b>12'0"</b>	3658 mm	<b>12'0"</b>	4267 mm	<b>14'0"</b>
Height	610 mm	<b>24.0"</b>	610 mm	<b>24.0"</b>	610 mm	<b>24.0"</b>
Thickness	22 mm	<b>0.87"</b>	22 mm	<b>0.87"</b>	22 mm	<b>0.87"</b>
Lift Above Ground	480 mm	<b>18.9"</b>	480 mm	<b>18.9"</b>	480 mm	<b>18.9"</b>
Max. Shoulder Reach:***						
Frame Straight — Left	1790 mm	<b>70.5"</b>	1790 mm	<b>70.5"</b>	2090 mm	<b>82.3"</b>
Frame Straight — Right	1978 mm	<b>77.9"</b>	1978 mm	<b>77.9"</b>	2278 mm	<b>89.7"</b>
Fuel Tank Capacity	394 L	<b>104 U.S. gal</b>	394 L	<b>104 U.S. gal</b>	394 L	<b>104 U.S. gal</b>
Diesel Exhaust Fluid Capacity	22.0 L	<b>5.8 U.S. gal</b>	22.0 L	<b>5.8 U.S. gal</b>	22.0 L	<b>5.8 U.S. gal</b>

\***Operating Weight** — based on standard machine configuration with full fuel tank, coolant, lubricants and operator.

\*\***Minimum Turning Radius** — combining the use of articulated frame steering, front wheel steer and unlocked differential.

\*\*\*Applicable for the standard blade with hydraulic sideshift and tip control. Maximum shoulder reach is obtainable to the right.

MODEL	14M3		16M3	
Base Power — Net	178 kW	238 hp	216 kW	290 hp
VHP Range — Net	178-213 kW	238-285 hp	216-259 kW	290-348 hp
VHP Plus Range — Net	180-215 kW	241-289 hp	—	—
Operating Weight*	25 968 kg	57,250 lb	32 411 kg	71,454 lb
Engine Model	C13 ACERT		C13 ACERT	
Rated Engine RPM	1850		2000	
No. of Cylinders	6		6	
Displacement	12.5 L	763 in <sup>3</sup>	12.5 L	763 in <sup>3</sup>
Max. Torque:				
Tier 4 Final <sup>1</sup>	1542 N·m	1137 lb-ft	1771 N·m	1306 lb-ft
Tier 2 and Tier 3 Equivalent <sup>2</sup>	1542 N·m	1137 lb-ft	1721 N·m	1270 lb-ft
No. of Speeds Forward/Reverse	8/6		8/6	
Top Speed: Forward	50.5 km/h	31.4 mph	51.7 km/h	32.1 mph
Reverse	39.9 km/h	24.8 mph	40.8 km/h	25.3 mph
Std. Tires — Front and Rear	20.5R25		23.5R25	
Front Axle/Steering:				
Oscillation Angle	32°		35°	
Wheel Lean Angle — Left/Right	17.1°/17.1°		18°/17°	
Steering Angle	50°		47.5°	
Articulation Angle	20°		20°	
Minimum Turning Radius**	7.9 m	25'11"	9.3 m	30'6"
No. Circle Support Shoes	6		6	
Hydraulics:				
Pump Type	Variable Piston		Variable Piston	
Max. Pump Flow	257 L/min	68 gpm	280 L/min	74 gpm
Tank Capacity	64 L	16.9 U.S. gal	70 L	18.5 U.S. gal
Implement Pressure: Max.	24 100 kPa	3495 psi	24 750 kPa	3590 psi
Min.	3400 kPa	493 psi	3400 kPa	493 psi
Interior Sound Level/SAE J919:				
Tier 4 Final/EU Certified <sup>1</sup>	73 dB(A)		71 dB(A)	
Tier 2 and Tier 3 Equivalent <sup>2</sup>	73 dB(A)		72 dB(A)	
Electrical:				
System Size	24V		24V	
Std. Battery CCA @ 0° F	1125		1400	
Std. Alternator	150		150	
GENERAL DIMENSIONS:				
Height (to top of ROPS)	3566 mm	140.4"	3719 mm	146.4"
Overall Length	9677 mm	381"	10 593 mm	417"
With Ripper and Pushplate	10 899 mm	429.1"	12 051 mm	474.4"
Wheelbase	6616 mm	260.5"	7365 mm	290"
Blade Base	2880 mm	113.4"	3066 mm	120.7"
Overall Width (at top of front tires)	3050 mm	120.1"	3411 mm	134.3"
Standard Blade: Length	4267 mm	14'0"	4877 mm	16'0"
Height	585 mm	23.0"	787 mm	31.0"
Thickness	25.4 mm	1.0"	25 mm	1.0"
Lift Above Ground	438 mm	17.2"	400 mm	15.7"
Max. Shoulder Reach:***				
Frame Straight — Left	3460 mm	136.2"	2311 mm	91"
Frame Straight — Right	3350 mm	131.9"	2311 mm	91"
Fuel Tank Capacity	416 L	109.9 U.S. gal	496 L	131 U.S. gal

\*Operating Weight — based on standard machine configuration with full fuel tank, coolant, lubricants and operator.

\*\*Minimum Turning Radius — combining the use of articulated frame steering, front wheel steer and unlocked differential.

\*\*\*Applicable for the standard blade with hydraulic sideshift and tip control. Maximum shoulder reach is obtainable to the right.

<sup>1</sup> Meets Tier 4 Final/Stage IV/Japan 2014 (Tier 4 Final) emission standards.

<sup>2</sup> Meets Tier 2/Stage II/Japan 2001 (Tier 2) equivalent and Tier 3/Stage IIIA/Japan 2006 (Tier 3) equivalent emission standards.

<b>MODEL</b>	<b>18M3</b>		<b>24M</b>	
Base Power — Net	227 kW	<b>304 hp</b>	397 kW	<b>533 hp</b>
VHP Range — Net	227-266 kW	<b>304-357 hp</b>	—	—
Operating Weight*	32 794 kg	<b>72,298 lb</b>	62 726 kg	<b>138,287 lb</b>
Engine Model	<b>C13 ACERT</b>		<b>C18 ACERT</b>	
Rated Engine RPM	<b>2000</b>		<b>1800</b>	
No. of Cylinders	<b>6</b>		<b>6</b>	
Displacement	12.5 L	<b>763 in<sup>3</sup></b>	18.1 L	<b>1104.5 in<sup>3</sup></b>
Max. Torque:	—		2713 N·m	
Tier 4 Final <sup>1</sup>	1771 N·m	<b>1306 lb-ft</b>	—	—
Tier 2 and Tier 3 Equivalent <sup>2</sup>	1721 N·m	<b>1270 lb-ft</b>	—	—
No. of Speeds Forward/Reverse	<b>8/6</b>		<b>6/3</b>	
Top Speed: Forward	51.7 km/h	<b>32.1 mph</b>	43.4 km/h	<b>27.0 mph</b>
Reverse	40.8 km/h	<b>25.3 mph</b>	41.6 km/h	<b>25.8 mph</b>
Std. Tires — Front and Rear	<b>23.5R25</b>		<b>29.5R29</b>	
Front Axle/Steering:	—		—	
Oscillation Angle	<b>35°</b>		<b>32°</b>	
Wheel Lean Angle — Left/Right	<b>18°/17°</b>		<b>18°/ 18°</b>	
Steering Angle	<b>47.5°</b>		<b>47.5°</b>	
Articulation Angle	<b>20°</b>		<b>25°</b>	
Minimum Turning Radius**	9.3 m	<b>30'6"</b>	12.4 m	<b>40'9"</b>
No. Circle Support Shoes	<b>6</b>		<b>6</b>	
Hydraulics:	—		—	
Pump Type	<b>Variable Piston</b>		<b>Variable Piston</b>	
Max. Pump Flow	280 L/min	<b>74 gpm</b>	550 L/min	<b>145 gpm</b>
Tank Capacity	70 L	<b>18.5 U.S. gal</b>	135 L	<b>36 U.S. gal</b>
Implement Pressure: Max.	24 750 kPa	<b>3590 psi</b>	24 150 kPa	<b>3500 psi</b>
Min.	3400 kPa	<b>493 psi</b>	3100 kPa	<b>450 psi</b>
Interior Sound Level/SAE J919:	—		<b>74 dB(A)</b>	
Tier 4 Final/EU Certified <sup>1</sup>	<b>71 dB(A)</b>		—	
Tier 2 and Tier 3 Equivalent <sup>2</sup>	<b>72 dB(A)</b>		—	
Electrical:	—		—	
System Size	<b>24V</b>		<b>24V</b>	
Std. Battery CCA @ 0° F	<b>1400</b>		<b>1500</b>	
Std. Alternator	<b>150</b>		<b>150</b>	
GENERAL DIMENSIONS:	—		—	
Height (to top of ROPS)	3719 mm	<b>146.4"</b>	4452 mm	<b>175.3"</b>
Overall Length	10 593 mm	<b>417"</b>	14 194 mm	<b>558.8"</b>
With Ripper and Pushplate	12 051 mm	<b>474.4"</b>	16 102 mm	<b>633.9"</b>
Wheelbase	7365 mm	<b>290"</b>	10 278 mm	<b>404.6"</b>
Blade Base	3066 mm	<b>120.7"</b>	4048 mm	<b>159.4"</b>
Overall Width (at top of front tires)	3411 mm	<b>134.3"</b>	4280 mm	<b>168.5"</b>
Standard Blade: Length	5511 mm	<b>18'0"</b>	7315 mm	<b>24'0"</b>
Height	787 mm	<b>31.0"</b>	1025 mm	<b>40.0"</b>
Thickness	25 mm	<b>1.0"</b>	50 mm	<b>2.0"</b>
Lift Above Ground	400 mm	<b>15.7"</b>	634 mm	<b>25.0"</b>
Max. Shoulder Reach:***	—		—	
Frame Straight — Left	2605 mm	<b>102.6"</b>	3222 mm	<b>126.9"</b>
Frame Straight — Right	2605 mm	<b>102.6"</b>	3228 mm	<b>127.1"</b>
Fuel Tank Capacity	496 L	<b>131 U.S. gal</b>	1326 L	<b>350 U.S. gal</b>

\***Operating Weight** — based on standard machine configuration with full fuel tank, coolant, lubricants and operator. 24M includes ripper.

\*\***Minimum Turning Radius** — combining the use of articulated frame steering, front wheel steer and unlocked differential.

\*\*\*Applicable for the standard blade with hydraulic sideshift and tip control. Maximum shoulder reach is obtainable to the right.

<sup>1</sup> Meets Tier 4 Final/Stage IV/Japan 2014 (Tier 4 Final) emission standards.

<sup>2</sup> Meets Tier 2/Stage II/Japan 2001 (Tier 2) equivalent and Tier 3/Stage IIIA/Japan 2006 (Tier 3) equivalent emission standards.

**TRAVEL SPEEDS @ MAXIMUM RPM WITH STD. TIRES (M/M2/M3 SERIES)**

Gear		1		2		3		4		5		6		7		8	
		km/h	mph	km/h	mph	km/h	mph	km/h	mph	km/h	mph	km/h	mph	km/h	mph	km/h	mph
120M	Forward	4.1	2.6	5.6	3.5	8.2	5.1	11.2	7.0	17.5	10.8	23.7	14.8	32.7	20.3	47.5	29.5
	Reverse	3.3	2.0	6.1	3.8	8.9	5.5	13.8	8.6	25.8	16.0	37.5	23.3	—	—	—	—
120M2	Forward	4.0	2.5	5.4	3.4	7.8	4.8	10.8	6.7	16.8	10.4	22.8	14.2	31.4	19.5	45.7	28.4
	Reverse	3.1	1.9	5.9	3.9	8.5	5.3	13.2	8.2	24.8	15.4	36.1	22.4	—	—	—	—
12M	Forward	4.0	2.5	5.5	3.4	8.0	5.0	11.0	6.8	17.1	10.6	23.3	14.5	32.0	19.9	46.6	29.0
	Reverse	3.2	2.0	6.0	3.7	8.7	5.4	13.5	8.4	25.3	15.7	36.8	22.9	—	—	—	—
12M2	Forward	4.1	2.5	5.5	3.4	8.0	5.0	11.0	6.9	17.1	10.6	23.3	14.5	32.0	19.9	46.6	29.0
	Reverse	3.2	2.0	6.0	3.7	8.7	5.4	13.5	8.4	25.3	15.7	36.8	22.9	—	—	—	—
12M3	Forward	4.1	2.5	5.5	3.4	8.0	5.0	11.0	6.9	17.1	10.6	23.3	14.5	32.0	19.9	46.6	29.0
	Reverse	3.2	2.0	6.0	3.7	8.7	5.4	13.5	8.4	25.3	15.7	36.8	23.0	—	—	—	—
140M	Forward	4.0	2.5	5.5	3.4	8.0	5.0	11.0	6.9	17.1	10.6	23.3	14.5	32.0	19.9	46.6	29.0
	Reverse	3.2	2.0	6.0	3.7	8.7	5.4	13.5	8.4	25.3	15.7	36.8	22.9	—	—	—	—
140M2	Forward	4.1	2.5	5.5	3.4	8.0	5.0	11.0	6.9	17.1	10.6	23.3	14.5	32.0	19.9	46.6	29.0
	Reverse	3.2	2.0	6.0	3.7	8.7	5.4	13.5	8.4	25.3	15.7	36.8	22.9	—	—	—	—
140M3	Forward	4.1	2.5	5.5	3.4	8.0	5.0	11.0	6.9	17.1	10.6	23.3	14.5	32.0	19.9	46.6	29.0
	Reverse	3.2	2.0	6.0	3.7	8.7	5.4	13.5	8.4	25.3	15.7	36.8	23.0	—	—	—	—
160M	Forward	4.1	2.5	5.6	3.5	8.1	5.0	11.2	7.0	17.4	10.8	23.7	14.7	32.6	20.3	47.4	29.5
	Reverse	3.3	2.0	6.1	3.8	8.8	5.5	13.7	8.5	25.7	16.0	37.4	23.3	—	—	—	—
160M2	Forward	4.1	2.6	5.6	3.5	8.1	5.1	11.2	7.0	17.4	10.8	23.7	14.7	32.6	20.3	47.4	29.5
	Reverse	3.3	2.0	6.1	3.8	8.9	5.5	13.7	8.5	25.7	16.0	37.4	23.3	—	—	—	—
160M3	Forward	4.1	2.6	5.6	3.5	8.1	5.1	11.2	7.0	17.4	10.8	23.7	14.7	32.6	20.3	47.4	29.5
	Reverse	3.3	2.0	6.1	3.8	8.8	5.5	13.7	8.5	25.7	16.0	37.4	23.3	—	—	—	—
14M3	Forward	4.4	2.7	5.9	3.7	8.6	5.3	11.8	7.4	18.4	11.4	24.9	15.5	34.3	21.3	49.9	31.0
	Reverse	3.4	2.1	6.4	4.0	9.4	5.8	14.5	9.0	27.0	16.8	39.4	24.5	—	—	—	—
16M3	Forward	4.5	2.8	6.1	3.8	8.9	5.5	12.3	7.6	19.0	11.8	25.8	16.0	35.5	22.0	51.7	32.1
	Reverse	3.6	2.2	6.6	4.1	9.7	6.0	15.0	9.3	28.0	17.4	40.8	25.3	—	—	—	—
18M3	Forward	4.5	2.8	6.1	3.8	8.9	5.5	12.3	7.6	19.0	11.8	25.8	16.0	35.5	22.0	51.7	32.1
	Reverse	3.6	2.2	6.6	4.1	9.7	6.0	15.0	9.3	28.0	17.4	40.8	25.3	—	—	—	—
24M	Forward	3.7	2.3	5.7	3.6	9.7	6.0	15.1	9.4	28.0	17.4	43.4	27.0	—	—	—	—
	Reverse	5.5	3.4	14.5	9.0	41.6	25.8	—	—	—	—	—	—	—	—	—	—

**NOTE:** 120M speeds were calculated with a 628 mm (24.7") tire at 2000 rpm rated speed.  
 120M2 speeds were calculated with a 620 mm (24.4") tire at high idle, 2150 rpm.  
 12M2-160M2 speeds were calculated with a 655 mm (25.8") tire at high idle, 2150 rpm.  
 12M3-160M3 speeds were calculated with a 655 mm (25.8") tire at 2000 rpm rated speed.



**TRAVEL SPEEDS @ MAXIMUM RPM WITH STD. TIRES (K/K2 SERIES)**

Gear		1		2		3		4		5		6		7		8	
		km/h	mph	km/h	mph	km/h	mph	km/h	mph	km/h	mph	km/h	mph	km/h	mph	km/h	mph
120K	Forward	4.1	2.5	5.5	3.4	8.0	5.0	11.1	6.9	17.5	10.8	23.7	14.8	32.7	20.3	47.5	29.5
	Reverse	3.2	2.0	6.0	3.7	8.7	5.4	13.8	8.6	25.8	16.0	37.5	23.3	—	—	—	—
120K2	Forward	4.1	2.5	5.5	3.4	8.0	5.0	11.1	6.9	17.5	10.8	23.7	14.8	32.7	20.3	47.5	29.5
	Reverse	3.2	2.0	6.0	3.7	8.7	5.4	13.8	8.6	25.8	16.0	37.5	23.3	—	—	—	—
12K	Forward	4.0	2.5	5.4	3.4	7.9	4.9	10.9	6.8	17.1	10.6	23.3	14.5	32.0	19.9	46.8	29.0
	Reverse	3.2	2.0	5.9	3.7	8.6	5.3	13.5	8.4	25.3	15.7	36.8	22.9	—	—	—	—
140K	Forward	4.1	2.5	5.5	3.4	8.0	5.0	11.0	6.9	17.4	10.8	23.6	14.7	32.5	20.2	47.3	29.4
	Reverse	3.2	2.0	6.0	3.7	8.7	5.4	13.7	8.5	25.7	16.0	37.4	23.2	—	—	—	—
140K2	Forward	4.1	2.5	5.5	3.4	8.0	5.0	11.0	6.9	17.4	10.8	23.6	14.7	32.5	20.2	47.3	29.4
	Reverse	3.2	2.0	6.0	3.7	8.7	5.4	13.7	8.5	25.7	16.0	37.4	23.2	—	—	—	—
160K	Forward	4.1	2.5	5.5	3.4	8.1	5.0	11.1	6.9	17.2	10.7	23.4	14.6	32.2	20.0	46.9	29.1
	Reverse	3.2	2.0	6.0	3.7	8.8	5.4	13.6	8.4	25.4	15.8	37.0	23.0	—	—	—	—

<b>ALL WHEEL DRIVE (AWD)</b>	<b>120M/120M2, 12M2/M3, 140M/M2/M3, 160M/M2/M3</b>	
Working Range:		
Forward Gears	<b>gears 1-7</b>	
Reverse Gears	<b>gears 1-5</b>	
Pump Type	<b>Variable Displacement Axial Piston Pumps (2)</b>	
Motor Type	<b>Variable Displacement Axial Piston Motors (2)</b>	
Front Wheel Gear Reduction	<b>Double Planetary Reduction</b>	
Maximum Pump Flow (each pump)	125 L/min	<b>33 gpm</b>
Front Wheel Torque	13 998 N·m	<b>10,325 lb-ft</b>
Control Type	<b>Speed control with closed-loop feedback</b>	

The optional AWD system utilizes dedicated left and right pumps for precise hydraulic control.

Hydrostatic Mode disengages the transmission and provides hydraulic power to the front wheels only-infininitely variable to 8 km/h (5 mph).

Exclusive AWD Steering Compensation adjusts outside front tire speed up to 50% faster than the inside tire.

Operating Pressure depends on engine speed, gear selection and operating conditions.

<b>M10 – MID MOUNT SCARIFIER</b>	<b>120M/M2, 12M/M2/M3, 140M/M2/M3, 160M/M2/M3</b>			
Type	<b>V-type</b>		<b>Straight type*</b>	
Working Width	1184 mm	<b>46.6"</b>	1800 mm	<b>71"</b>
Depth (Max.)	292 mm	<b>11.5"</b>	317 mm	<b>12.5"</b>
Number of Shank Holders	<b>11</b>		<b>17</b>	
Spacing	116 mm	<b>4.6"</b>	111 mm	<b>4.4"</b>

\*Available on M Series Global Versions only.

<b>FRONT MOUNT SCARIFIER</b>	<b>120M/M2, 12M/M2/M3, 140M/M2/M3, 160M/M2/M3</b>		
Type	<b>V-type</b>		
Working Width	1205 mm		<b>47.4"</b>
Depth (Max.)	467 mm		<b>18.4"</b>
Number of Shank Holders	<b>11</b>		
Spacing	116 mm		<b>4.6"</b>

MOTOR GRADER/RIPPER	120M		120M2		12M		12M2	
Parallelogram — Rear Mounted	Ripper/ Scarifier		Ripper/ Scarifier		Ripper/ Scarifier		Ripper/ Scarifier	
Tire Size (Std.)	13.00 24		13.00 24		14R24		14.00R24	
Front and Rear	12PR (G-4)		12PR (G-2)		12PR (G-2)		★ (G-2)	
<b>Scarifier</b>								
Maximum Digging Depth	267 mm	10.5"	267 mm	10.5"	267 mm	10.5"	267 mm	10.5"
Number of Pockets	9		9		9		9	
Spacing	267 mm	10.5"	267 mm	10.5"	267 mm	10.5"	267 mm	10.5"
<b>Ripper Shank</b>								
Maximum Digging Depth	428 mm	16.9"	428 mm	16.9"	428 mm	16.9"	428 mm	16.9"
Maximum Reach at Ground Line	973 mm	38.3"	973 mm	38.3"	973 mm	38.3"	973 mm	38.3"
Maximum Ground Clearance under Tip (shank pinned in bottom hole)	502 mm	19.8"	502 mm	19.8"	502 mm	19.8"	502 mm	19.8"
Maximum Ramp Angle, Ripper Up, Shanks in Working Position (shank pinned in bottom hole)	14.5°		13.5°		14.5°		15.0°	
Shank Section	59 × 138 mm 2.3" × 5.4"		59 × 138 mm 2.3" × 5.4"		59 × 138 mm 2.3" × 5.4"		59 × 138 mm 2.3" × 5.4"	
<b>Ripper Beam</b>								
Overall Width	2.31 m	7'7"	2.31 m	7'7"	2.31 m	7'7"	2.31 m	7'7"
Height	152 mm	6.0"	152 mm	6.0"	152 mm	6.0"	152 mm	6.0"
Length	230 mm	9.1"	230 mm	9.1"	230 mm	9.1"	230 mm	9.1"
Number of Pockets	5		5		5		5	
Pocket Spacing:								
Inside	533 mm	1'9"	533 mm	1'9"	533 mm	1'9"	533 mm	1'9"
Middle	533 mm	1'9"	533 mm	1'9"	533 mm	1'9"	533 mm	1'9"
Outside	533 mm	1'9"	533 mm	1'9"	533 mm	1'9"	533 mm	1'9"
Shank Gauge	2.13 m	7'0"	2.13 m	7'0"	2.13 m	7'0"	2.13 m	7'0"
Installed Weights:								
Ripper with Standard Shank	1100 kg	2425 lb	1100 kg	2425 lb	1111 kg	2449 lb	1086 kg	2394 lb
Each Additional Shank	31 kg	68 lb	31 kg	68 lb	31 kg	68 lb	31 kg	68 lb
Ripper Forces:								
Penetration Force	8454 kg	18,638 lb	9106 kg	20,075 lb	9189 kg	20,258 lb	9440 kg	20,812 lb
Pryout Force	10 024 kg	22,099 lb	10 616 kg	23,404 lb	11 635 kg	25,651 lb	12 430 kg	27,403 lb

<b>MOTOR GRADER/RIPPER</b>	<b>12M3</b>		<b>140M</b>		<b>140M2</b>		<b>140M3</b>	
<b>Parallelogram — Rear Mounted</b>	<b>Ripper/Scarifier</b>		<b>Ripper/Scarifier</b>		<b>Ripper/Scarifier</b>		<b>Ripper/Scarifier</b>	
<b>Tire Size (Std.)</b>	<b>14.00R24</b>		<b>14.00-24</b>		<b>14.00R24</b>		<b>14.00R24</b>	
<b>Front and Rear</b>	<b>★ (G-2)</b>		<b>10PR (G-2)</b>		<b>★ (G-2)</b>		<b>★ (G-2)</b>	
<b>Scarifier</b>								
Maximum Digging Depth	267 mm	<b>10.5"</b>	261 mm	<b>10.3"</b>	265 mm	<b>10.4"</b>	265 mm	<b>10.4"</b>
Number of Pockets	<b>9</b>		<b>9</b>		<b>9</b>		<b>9</b>	
Spacing	267 mm	<b>10.5"</b>	267 mm	<b>10.5"</b>	267 mm	<b>10.5"</b>	267 mm	<b>10.5"</b>
<b>Ripper Shank</b>								
Maximum Digging Depth	428 mm	<b>16.9"</b>	422 mm	<b>16.6"</b>	426 mm	<b>16.8"</b>	426 mm	<b>16.8"</b>
Maximum Reach at Ground Line	973 mm	<b>38.3"</b>	973 mm	<b>38.3"</b>	973 mm	<b>38.3"</b>	973 mm	<b>38.3"</b>
Maximum Ground Clearance under Tip (shank pinned in bottom hole)	502 mm	<b>19.8"</b>	508 mm	<b>20"</b>	488 mm	<b>19.2"</b>	488 mm	<b>19.2"</b>
Maximum Ramp Angle, Ripper Up, Shanks in Working Position (shank pinned in bottom hole)	<b>15.0°</b>		<b>15.3°</b>		<b>15.0°</b>		<b>15.0°</b>	
Shank Section	59 × 138 mm <b>2.3" × 5.4"</b>		59 × 138 mm <b>2.3" × 5.4"</b>		59 × 138 mm <b>2.3" × 5.4"</b>		59 × 138 mm <b>2.3" × 5.4"</b>	
<b>Ripper Beam</b>								
Overall Width	2.31 m	<b>7'7"</b>	2.31 m	<b>7'7"</b>	2.31 m	<b>7'7"</b>	2.31 m	<b>7'7"</b>
Height	152 mm	<b>6.0"</b>	152 mm	<b>6.0"</b>	152 mm	<b>6.0"</b>	152 mm	<b>6.0"</b>
Length	230 mm	<b>9.1"</b>	230 mm	<b>9.1"</b>	230 mm	<b>9.1"</b>	230 mm	<b>9.1"</b>
Number of Pockets	<b>5</b>		<b>5</b>		<b>5</b>		<b>5</b>	
Pocket Spacing:								
Inside	533 mm	<b>1'9"</b>	533 mm	<b>1'9"</b>	533 mm	<b>1'9"</b>	533 mm	<b>1'9"</b>
Middle	533 mm	<b>1'9"</b>	533 mm	<b>1'9"</b>	533 mm	<b>1'9"</b>	533 mm	<b>1'9"</b>
Outside	533 mm	<b>1'9"</b>	533 mm	<b>1'9"</b>	533 mm	<b>1'9"</b>	533 mm	<b>1'9"</b>
Shank Gauge	2.13 m	<b>7'0"</b>	2.13 m	<b>7'0"</b>	2.13 m	<b>7'0"</b>	2.13 m	<b>7'0"</b>
Installed Weights:								
Ripper with Standard Shank	1086 kg	<b>2394 lb</b>	1111 kg	<b>2449 lb</b>	1086 kg	<b>2394 lb</b>	1086 kg	<b>2394 lb</b>
Each Additional Shank	31 kg	<b>68 lb</b>	31 kg	<b>68 lb</b>	31 kg	<b>68 lb</b>	31 kg	<b>68 lb</b>
Ripper Forces:								
Penetration Force	9440 kg	<b>20,812 lb</b>	9440 kg	<b>20,812 lb</b>	9440 kg	<b>20,812 lb</b>	9440 kg	<b>20,812 lb</b>
Pryout Force	12 607 kg	<b>27,794 lb</b>	12 147 kg	<b>26,780 lb</b>	12 943 kg	<b>28,534 lb</b>	12 607 kg	<b>27,794 lb</b>

<b>MOTOR GRADER/RIPPER</b>	<b>160M</b>		<b>160M2</b>		<b>160M3</b>	
<b>Parallelogram — Rear Mounted</b>	<b>Ripper/ Scarifier</b>		<b>Ripper/ Scarifier</b>		<b>Ripper/ Scarifier</b>	
<b>Tire Size (Std.)</b>	<b>14.00-24</b>		<b>14.00R24</b>		<b>14.00R24</b>	
<b>Front and Rear</b>	<b>10PR (G-2)</b>		<b>★ (G-2)</b>		<b>★ (G-2)</b>	
<b>Scarifier</b>						
Maximum Digging Depth	261 mm	<b>10.3"</b>	265 mm	<b>10.4"</b>	265 mm	<b>10.4"</b>
Number of Pockets	<b>9</b>		<b>9</b>		<b>9</b>	
Spacing	267 mm	<b>10.5"</b>	267 mm	<b>10.5"</b>	267 mm	<b>10.5"</b>
<b>Ripper Shank</b>						
Maximum Digging Depth	422 mm	<b>16.6"</b>	426 mm	<b>16.8"</b>	426 mm	<b>16.8"</b>
Maximum Reach at Ground Line	973 mm	<b>38.3"</b>	973 mm	<b>38.3"</b>	973 mm	<b>38.3"</b>
Maximum Ground Clearance under Tip (shank pinned in bottom hole)	508 mm	<b>20"</b>	488 mm	<b>19.2"</b>	488 mm	<b>19.2"</b>
Maximum Ramp Angle, Ripper Up, Shanks in Working Position (shank pinned in bottom hole)	<b>15.3°</b>		<b>15.0°</b>		<b>15.0°</b>	
Shank Section	59 × 138 mm <b>2.3" × 5.4"</b>		59 × 138 mm <b>2.3" × 5.4"</b>		59 × 138 mm <b>2.3" × 5.4"</b>	
<b>Ripper Beam</b>						
Overall Width	2.31 m	<b>7'7"</b>	2.31 m	<b>7'7"</b>	2.31 m	<b>7'7"</b>
Height	152 mm	<b>6.0"</b>	152 mm	<b>6.0"</b>	152 mm	<b>6.0"</b>
Length	230 mm	<b>9.1"</b>	230 mm	<b>9.1"</b>	230 mm	<b>9.1"</b>
Number of Pockets	<b>5</b>		<b>5</b>		<b>5</b>	
Pocket Spacing:						
Inside	533 mm	<b>1'9"</b>	533 mm	<b>1'9"</b>	533 mm	<b>1'9"</b>
Middle	533 mm	<b>1'9"</b>	533 mm	<b>1'9"</b>	533 mm	<b>1'9"</b>
Outside	533 mm	<b>1'9"</b>	533 mm	<b>1'9"</b>	533 mm	<b>1'9"</b>
Shank Gauge	2.13 m	<b>7'0"</b>	2.13 m	<b>7'0"</b>	2.13 m	<b>7'0"</b>
Installed Weights:						
Ripper with Standard Shank	1111 kg	<b>2449 lb</b>	1086 kg	<b>2394 lb</b>	1086 kg	<b>2394 lb</b>
Each Additional Shank	31 kg	<b>68 lb</b>	31 kg	<b>68 lb</b>	31 kg	<b>68 lb</b>
Ripper Forces:						
Penetration Force	9440 kg	<b>20,812 lb</b>	9440 kg	<b>20,812 lb</b>	9440 kg	<b>20,812 lb</b>
Pryout Force	12 861 kg	<b>28,354 lb</b>	13 656 kg	<b>30,106 lb</b>	12 924 kg	<b>28,493 lb</b>

<b>MOTOR GRADER/RIPPER</b>	<b>14M3</b>		<b>16M3</b>	
<b>Parallelogram — Rear Mounted</b>	<b>Ripper</b>		<b>Ripper</b>	
<b>Tire Size (Std.)</b>	<b>20.5R25</b>		<b>23.5-25</b>	
<b>Front and Rear</b>	<b>—</b>		<b>12PR (G-2)</b>	
<b>Ripper Shank</b>				
Maximum Digging Depth	404 mm	<b>15.9"</b>	452 mm	<b>17.8"</b>
Maximum Reach at Ground Line	1062 mm	<b>41.8"</b>	1500 mm	<b>4'11"</b>
Maximum Ground Clearance under Tip (shank pinned in bottom hole)	617.7 mm	<b>24.3"</b>	673 mm	<b>2'2.5"</b>
Maximum Ramp Angle, Ripper Up, Shanks in Working Position (shank pinned in bottom hole)	<b>14.5°</b>		<b>14.3°</b>	
Shank Section	59 × 138 mm <b>2.3" × 5.4"</b>		76 × 178 mm <b>3" × 7"</b>	
<b>Ripper Beam</b>				
Overall Width	2595 mm	<b>102.2"</b>	2.98 m	<b>9'9"</b>
Height	165 mm	<b>6.5"</b>	214 mm	<b>8.4"</b>
Length	211 mm	<b>8.3"</b>	254 mm	<b>10"</b>
Number of Pockets	<b>7</b>		<b>7</b>	
Pocket Spacing:				
Inside	472 mm	<b>18.6"</b>	500 mm	<b>1'8"</b>
Middle	373 mm	<b>14.7"</b>	445 mm	<b>17.5"</b>
Outside	373 mm	<b>14.7"</b>	445 mm	<b>17.5"</b>
Installed Weights:				
Ripper with Standard Shank	1643 kg	<b>3622 lb</b>	2198 kg	<b>4836 lb</b>
Each Additional Shank	31 kg	<b>68 lb</b>	68 kg	<b>150 lb</b>
Ripper Forces:				
Penetration Force	13 116 kg	<b>28,916 lb</b>	13 749 kg	<b>30,311 lb</b>
Pryout Force	21 228 kg	<b>46,800 lb</b>	19 822 kg	<b>43,700 lb</b>

<b>MOTOR GRADER/RIPPER</b>	<b>18M3</b>		<b>24M</b>	
<b>Parallelogram – Rear Mounted</b>	<b>Ripper</b>		<b>Ripper</b>	
<b>Tire Size (Std.)</b>	<b>23.5-25</b>		<b>29.5-29</b>	
<b>Front and Rear</b>	<b>12PR (G-2)</b>		<b>28PR</b>	
<b>Ripper Shank</b>				
Maximum Digging Depth	452 mm	<b>178"</b>	490 mm	<b>1'7.3"</b>
Maximum Reach at Ground Line	1500 mm	<b>4'11"</b>	1165 mm	<b>3'9.9"</b>
Maximum Ground Clearance under Tip (shank pinned in bottom hole)	673 mm	<b>2'2.5"</b>	739 mm	<b>2'5.1"</b>
Maximum Ramp Angle, Ripper Up, Shanks in Working Position (shank pinned in bottom hole)	<b>14.3°</b>		<b>12.5°</b>	
Shank Section	76 × 178 mm <b>3" × 7"</b>		76 × 178 mm <b>3" × 7"</b>	
<b>Ripper Beam</b>				
Overall Width	2.98 m	<b>9'9"</b>	3.91 m	<b>12'10"</b>
Height	214 mm	<b>8.4"</b>	216 mm	<b>8.5"</b>
Length	254 mm	<b>10"</b>	254 mm	<b>10"</b>
Number of Pockets	<b>7</b>		<b>7</b>	
Pocket Spacing:				
Inside	500 mm	<b>1'8"</b>	593 mm	<b>1'11.4"</b>
Middle	445 mm	<b>17.5"</b>	604 mm	<b>1'11.8"</b>
Outside	445 mm	<b>17.5"</b>	604 mm	<b>1'11.8"</b>
Installed Weights:				
Ripper with Standard Shank	2198 kg	<b>4836 lb</b>	2812 kg	<b>6186 lb</b>
Each Additional Shank	68 kg	<b>150 lb</b>	68 kg	<b>150 lb</b>
Ripper Forces:				
Penetration Force	13 749 kg	<b>30,311 lb</b>	13 601 kg	<b>29,985 lb</b>
Pryout Force	19 822 kg	<b>43,700 lb</b>	18 621 kg	<b>41,052 lb</b>

## PRODUCTION

The motor grader is used in a variety of applications in a variety of industries. Therefore, there are many ways to measure its operating capacity, or production. One method expresses a motor grader's production in relation to the area covered by the moldboard.

### Formula:

$$A = S \times (L_e - L_o) \times 1000 \times E \text{ (Metric)}$$

$$A = S \times (L_e - L_o) \times 5280 \times E \text{ (English)}$$

where A: Hourly operating area (m<sup>2</sup>/h or ft<sup>2</sup>/h)

S: Operating speed (km/h or mph)

L<sub>e</sub>: Effective blade length (m or ft)

L<sub>o</sub>: Width of overlap (m or ft)

E: Job efficiency

## Operating Speeds:

Typical operating speeds by application

Finish Grading:	0-4 km/h	(0-2.5 mph)
Heavy Blading:	0-9 km/h	(0-6 mph)
Ditch Repair:	0-5 km/h	(0-3 mph)
Ripping:	0-5 km/h	(0-3 mph)
Road Maintenance:	5-16 km/h	(3-9.5 mph)
Haul Road Maintenance:	5-16 km/h	(3-9.5 mph)
Snow Plowing:	7-21 km/h	(4-13 mph)
Snow Winging:	15-28 km/h	(9-17 mph)

## Effective Blade Length:

Since the moldboard is usually angled when moving material, an effective blade length must be computed to account for this angle. This is the actual width of material swept by the moldboard.

**NOTE:** Angles are measured as shown below. The effective length becomes shorter as the angle increases.

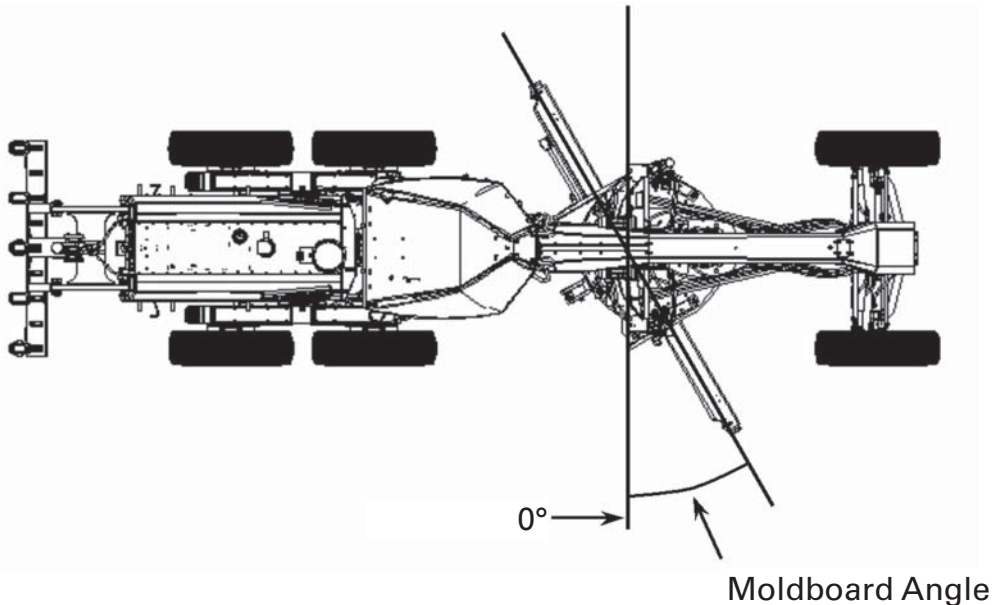



Moldboard Length, m (ft)	Effective Length, m (ft) 30 degree blade angle	Effective Length, m (ft) 45 degree blade angle
3.658 (12)	3.17 (10.4)	2.59 (8.5)
4.267 (14)	3.70 (12.1)	3.02 (9.9)
4.877 (16)	4.22 (13.9)	3.45 (11.3)
7.315 (24)	6.33 (20.8)	5.17 (17.0)

For other blade lengths and carry angles:  
 Effective length = COS [Radians (Blade L)] 3 Blade Length

**Width of Overlap:**

The width of overlap is generally 0.6 m (2.0 ft). This overlap accounts for the need to keep the tires out of the windrow on the return pass.

**Job Efficiency:**

Job efficiencies vary based on job conditions, operator skill, etc.

A good estimation for efficiency is approximately 0.70 to 0.85, but actual operating conditions should be used to determine the best value.

Example problem:

A Cat motor grader with a 3.66 m (12 ft) moldboard is performing road maintenance on a township road. The machine is working at an average speed of 13 km/h (8 mph) with a moldboard carry angle of 30 degrees. What is the motor grader’s production based on coverage area?

**Note:** Due to the long passes involved in road maintenance — fewer turnarounds — a higher job efficiency of 0.90 is chosen.

**Solution:**

From the table, the effective blade length is 3.17 m (10.4 ft).

*Metric*

$$\begin{aligned} \text{Production, A} &= 13 \text{ km/h} \times (3.17 \text{ m} - 0.6 \text{ m}) \times \\ &1000 \times 0.90 \\ &= \mathbf{30\ 069 \text{ m}^2/\text{hr} (3.07 \text{ hectares/hr})} \end{aligned}$$

*English*

$$\begin{aligned} \text{Production, A} &= 8 \text{ mph} \times (10.4 \text{ ft} - 2.0 \text{ ft}) \times \\ &5280 \times 0.90 \\ &= \mathbf{319,334 \text{ ft}^2/\text{hr} (7.33 \text{ acres/hr})} \end{aligned}$$

To pinpoint the theoretical number of motor graders required to properly maintain your haul roads, based on your specific mining applications, please download the haul road maintenance calculator on <https://catminer.cat.com>.

Haul road maintenance impacts cycle time, tire, frame and drive train components, safety and ultimately your cost per ton. To achieve optimal truck productivity, your haul roads must be properly maintained.

- Moderate: ● Road Maintenance  
 ● Pad Cleaning  
 ● Rock Clearing  
 ● Shoulder Sweeping

- Difficult: ● Ripping  
 ● Spreading Dump Material  
 ● Road Profiling/Reshaping

### BLADE PULL

This specification is also known as drawbar pull. This spec can be calculated as follows:

Variables:

Rear weight of machine = Wr

Tire traction coefficient = T (Look up the table entitled "Coefficient of Traction Factors")

$$Wr \times T = \text{Blade Pull}$$

Example problem:

Calculate the blade pull for a 140M Global Version machine operating in a quarry pit...

Metric

RW = 10 501 kg

T = 0.65

$$10\,501 \times 0.65 = 6825.65$$

English

RW = 23,151 lb

T = 0.65

$$23,151 \times 0.65 = 15,048.15$$

### BLADE DOWN PRESSURE

This spec can be calculated as follows:

Variables:

Blade to front axle length = BA

Wheel base length = WB

Weight on front wheels = FW

Blade down pressure = BD

$$\frac{WB}{(WB - BA)} \times FW = BD$$

Example problem:

Calculate the blade down pressure for a 140M Global Version machine...

Metric

BA = 2565 mm                      FW = 4223 kg

WB = 6086 mm                    BD = ?

$$\frac{6086}{(6086 - 2565)} \times 4223 = 7299 \text{ kg}$$

English

BA = 101 in

FW = 9310 lb

WB = 240 in

BD = ?

$$\frac{240}{(240 - 101)} \times 9310 = 16,075 \text{ lb}$$

This specification is only a minor indicator of a motor grader's productivity. It alone gives no measure of overall machine productivity. When considering motor grader production you need an optimum balance between the machine's front and rear weights. If a machine has too much weight on the front axle, it might have a high blade down pressure spec. It will, however, lack the essential rear weight and traction needed to push through the load. Too much weight in the rear and it will not have the necessary weight in the front during heavy cuts to maintain proper steering control.

Cat machines are built with this optimum balance in mind. A Cat motor grader is engineered with the proper weight distribution necessary for maximum productivity.

Effective Blade Length\*

		Moldboard							
		3.66 m (12')		4.27 m (14')		4.88 m (16')		7.32 m (24')	
Angle°		m	ft	m	ft	m	ft	m	ft
	0°	3.66	12.00	4.27	14.00	4.88	16.00	7.32	24.00
	5°	3.64	11.95	4.25	13.95	4.86	15.94	7.29	23.91
	10°	3.60	11.82	4.20	13.79	4.80	15.76	7.21	23.64
	15°	3.53	11.59	4.12	13.52	4.71	15.45	7.07	23.18
	20°	3.44	11.28	4.01	13.16	4.58	15.04	6.87	22.55
	25°	3.32	10.88	3.87	12.69	4.42	14.50	6.63	21.75
	30°	3.17	10.39	3.69	12.12	4.22	13.86	6.33	20.78
	35°	3.00	9.83	3.50	11.47	4.00	13.11	5.99	19.66
	40°	2.80	9.19	3.27	10.72	3.74	12.26	5.61	18.39
45°	2.59	8.49	3.02	9.90	3.45	11.31	5.17	16.97	

\*Effective blade length is the amount of blade coverage the machine is capable of when the blade is at a given angle.

## EXTREME SLOPE OPERATION

There are two ways of defining slope work. The slope perpendicular to the machine's direction of travel is commonly referred to as "Side Sloping." The slope parallel to the machine's direction of travel — the machine's ability to travel up or down terrain, is commonly referred to as "Gradeability."

Side Sloping capability for our Cat graders is somewhat subjective, but general agreement among professional operators is that working on a slope ratio of 2.5:1 (21.8 degrees) is the safe limit ... an experienced operator may be able to operate on a 2:1 (28 degrees) slope. Many factors influence this limit such as operator experience, machine configuration, tires and soil conditions, but a 2.5:1 is achievable. Further, a 3:1 slope is the approximate maximum side slope a grader can work on in straight frame configuration. The steeper side slopes all require the machine be articulated to safely navigate the slope.

Gradeability is approximately 22 degrees. This is established by the grader's ability to stop without skidding the tires while moving downhill. The motor grader can, however, *climb* grades steeper than 22 degrees. The traction coefficient is the critical factor in determining whether a grader can safely navigate the slope. Caterpillar recommends that you never climb a slope steeper than you can safely descend.

Maximum lubrication angle: We have measured the graders on a tilt table and pump cavitation occurs around 30 degrees (58% or 1.7:1). This is beyond the grade or slope a motor grader can operate on.

When working side hills and slopes, consideration should be given to the following important points.

- **Speed of Travel** — At higher speeds, inertia forces tend to make the grader less stable.
- **Roughness of Terrain or Surface** — Ample allowance should be made where the terrain or surface is uneven.
- **Mounted Equipment** — Mounted attachments such as front plows, snow wings, rippers and other mounted equipment cause the tractor to balance differently.
- **Nature of Surface** — New earthen fills may give way with the weight of the grader. Rocky surfaces may promote side slipping of grader.
- **Excessive Loads or Side Draft** — This may cause wheel slippage, where the downhill tires "dig in," increasing the angle of grader.
- **Tire Selection and Maintenance** — Consideration should be given to proper tire selection and air pressure. For more information, consult Caterpillar publications — Motor Grader Tire Selection Guide and Operation and Maintenance Manual.
- **Drawbar, Circle and Blade Position** — The position of the blade can affect the stability of the machine.
- **Articulation Angle** — Articulation angle can affect the stability of the machine.
- **Wheel Lean Angle** — Wheel lean angle can affect the stability of the machine.

**NOTE:** Safe operation on steep slopes may require special machine maintenance as well as excellent operator skill and proper equipment setup for the specific application. Consult Caterpillar publications for further operating tips — Operation & Maintenance Manual, Motor Grader Application Guide, and the Grade Comparison Chart in the Tables section of this Performance Handbook.

Work Tool	120M/ 120M2	12M/ 12M2/ 12M3	140M/ 140M2/ 140M3	160M/ 160M2/ 160M3	16M3/ 18M3	14M3	24M
	Lift Group	x	x	x	x	x	x
V-Plow	x	x	x	x	—	x	—
One Way Plow	x	x	x	x	—	x	—
Manual Reversible Plow	—	—	—	—	—	x	—
Hydraulic Reversible Plow	x	x	x	x	—	x	—
Snow Wing	x	x	x	x	—	x	—
Mid Mount Scarifier	x	x	x	—	—	—	—
Front Scarifier	x	x	x	x	—	x	—
Manual Angle Blade	x	x	x	x	—	x	—
Hydraulic Angle Blade	x	x	x	x	—	x	—
Straight Blade	x	x	x	x	x	x	—

This list is not all-inclusive.

See Price Lists, Cat Work Tools (Cat WT) Price List, and your Cat dealer for special attachment needs.

Attachments for Cat motor graders require additional hydraulics.

Most front-mounted attachments require a Quick Attach-Detach Parallel Lift Group.



# ON-HIGHWAY TRUCKS (for Sale in North America Only)

## CONTENTS

Preface . . . . .	12-1
Features . . . . .	12-2
Chassis Types . . . . .	12-3
Specifications . . . . .	12-12
Weight Distribution . . . . .	12-13
GVWR and GCWR . . . . .	12-14
Frame Selection . . . . .	12-15
Selecting Gear Ratios for Transmission and Axles . . . . .	12-18
Engine Selection . . . . .	12-19
Driveline Braking . . . . .	12-23
Appendix A Reference Equations (English Units) . . . . .	12-24
Appendix B Vehicle Identification Number (VIN Structure) . . . . .	12-25
Appendix C CT13 Torque Curves . . . . .	12-26
Appendix D Transmission Specifications . . . . .	12-32
Appendix E Rear Axle Specifications . . . . .	12-36
Appendix F Front Axle Specifications . . . . .	12-38
Lift Axle Specifications . . . . .	12-38
Appendix G CX31 Startability Reference Guide . . . . .	12-39
Appendix H Front Tire Specifications . . . . .	12-40
Appendix I Rear Tire Specifications . . . . .	12-42
Appendix J Front Suspension Specifications . . . . .	12-46
Appendix K Rear Suspension Details . . . . .	12-48
Appendix L Rear Suspension Specifications . . . . .	12-51
Appendix M Power Take Off Specifications . . . . .	12-52

## PREFACE

This handbook is a guide that can be used as a first step when configuring a truck. It allows the user to examine options and variables that affect performance of the driveline and frame.

Trucks are highly configurable machines. There are numerous choices for every major component (frame, engine, transmission, tires, axles, suspension, gear ratios, etc.). It's critical not to over or under spec a truck for an application. A well spec'd truck is typically a balance between variables like cost, GVWR, maximum speed, gradeability, startability, and fuel economy. There are also intangibles like driver preference, serviceability, and customer history to consider.

The equations and methodology in this handbook are provided to help select components and predict how they will work together to create a truck with the desired level of performance.

Time spent investigating the customers needs is critical for creating a well configured truck that will meet or exceed customer expectations. Normally, experts with years of experience and/or classroom training perform this type of work.

## FEATURES

### Cat® CT13 Engines

- **Cat CT Series Engines** meet EPA regulatory requirements.
- **6 cylinder — 4 valve per cylinder with intercooled dual turbochargers** for excellent response.
- **High pressure common rail fuel system** improves fuel efficiency and reduces soot.
- **Compact graphite iron block (13L)** reduces weight/ noise and increases strength.
- **Separate cooling and oil passages for block and head** to eliminate head gasket leaks.

### Transmission

- **Cat CX31 full automatic:** 6 speed (based on Cat 730 articulated transmission).
  - Full electronic control allows Jake Brake integration and advanced body builder options.
  - Two standard power takeoff ports at 1 o'clock and 8 o'clock.
  - Optional rear power takeoff port allows easier access to install and service pumps.
  - External solenoids and filter allow for quicker maintenance and troubleshooting.
  - Torque converter locks up near the end of 2nd gear. Can be programmed to lock in 1st gear.
- **Eaton Fuller manual transmission:** 10–18 speeds. 10 speed manual standard.
- **Eaton Fuller Ultrashift Plus Vocational:** 10–18 speeds.

### Cab Exterior

- **Premium, conventional, aluminum alloy cab** (riveted + glued) for extra strength.
- **Sloped Metton hood** for CT660 provides excellent visibility to the ground.
- **Large curved front window (1 or 2 piece)** for maximum visibility to the sides.
- **Cowl mounted mirrors** that are heated, powered, lit, and break away to reduce impact damage.
- **Three piece bumper and grill surround** for CT660 and CT680 reduces repair costs after an impact.
- **TPO fender flairs** protect the hood.
- **Piano style door hinges** for a super tight seal and to reduce wind noise.
- **Front mounted PTO (FEMPTO)** for CT681.
- **Integral front frame extensions** for CT681.
- **Stationary grill** for CT681.

### Cab Interior

- **Premium grade sound insulation package** reduces operator fatigue.
- **Primary gauges** are clearly visible through the steering wheel for easy access.
- **Powered mirrors, windows, and door locks.**
- **Ergonomic dash board with tilted center stack** for easy access and storage.
- **Large rocker switches with tactile feedback.** Can be used with gloves on.
- **Maximized door, dash, overhead, and back panel storage.**
- **Radio (hands free cell, CD, USB, 1/8 auxiliary) + factory installed CB wiring.**
- **Oversized HVAC system** for quick maximum heating, defrosting, and cooling.

Chassis Types

- CT660L
- SBA ● 122 BBC ● 4x4
- All Axles Powered

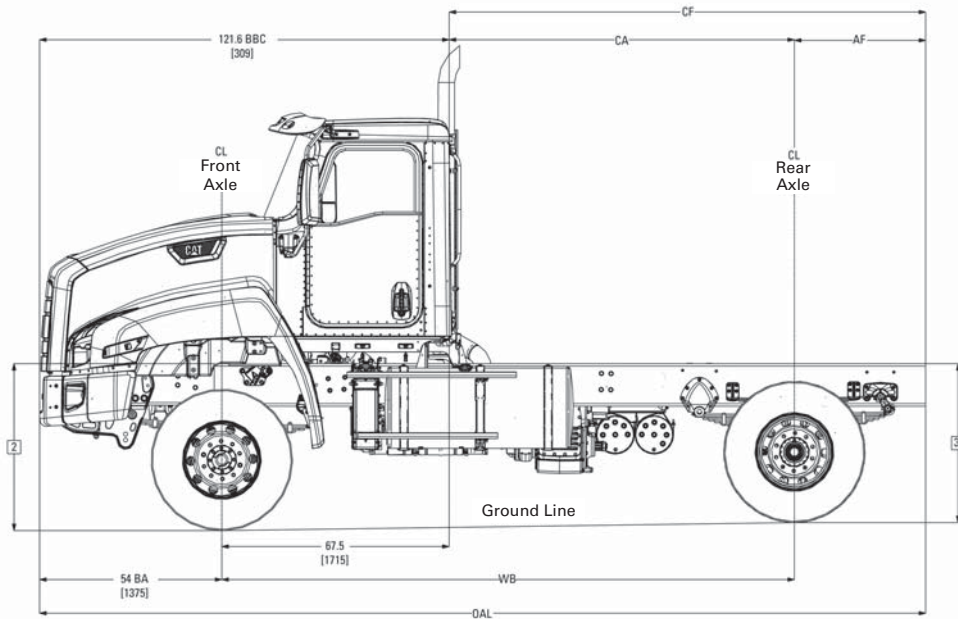

Wheelbase (in)	Chassis Weight (lb)*			Dimensions (in)				Turning Radius**
	Front	Rear	Total	CA	CF	AF	OAL	To Curb
170	11,346	5466	16,812	101.4	154.5	39	270.6	22'0"
188				119.1	172.2	39	288.3	23'10"
206				136.8	190	39	306	25'7"

\*Weight includes standard chassis, oil and water, less fuel.

\*\*Maximum turning radius with 11R22.5 tires.



# On-Highway Trucks

## Chassis Types

- CT660L
- SBA ● 122 BBC ● 6x6
- All Axles Powered

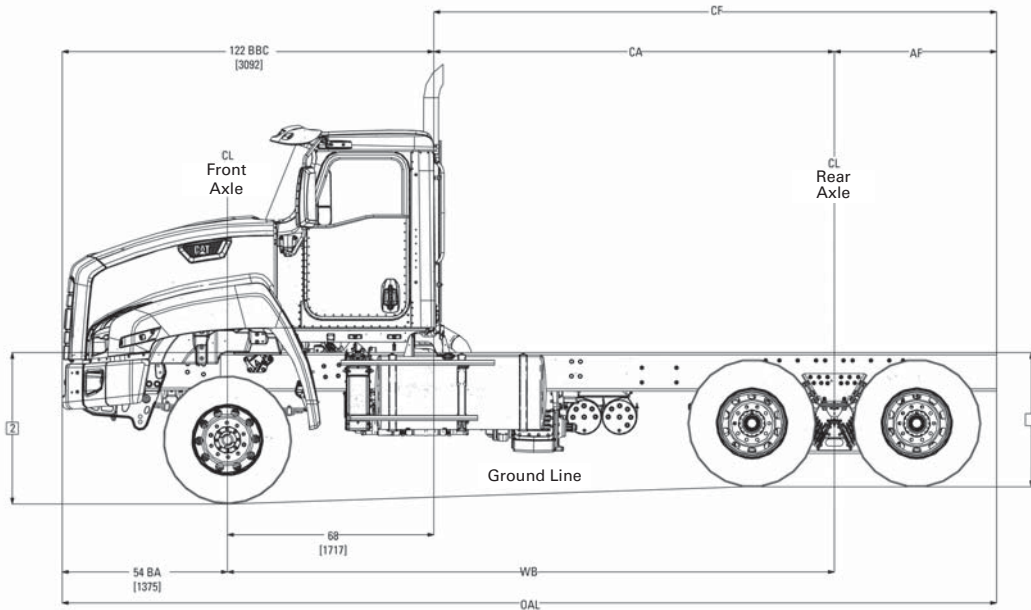

Wheelbase (in)	Chassis Weight (lb)*			Dimensions (in)				Turning Radius**
	Front	Rear	Total	CA	CF	AF	OAL	To Curb
163				95.4	148.5	53	270.6	21'4"
181				113.1	166.2	53	288.3	23'1"
199	11,348	7199	18,547	130.8	184	53	306	24'11"
211				195.8	195.8	53	317.8	26'1"

\*Weight includes standard chassis, oil and water, less fuel.

\*\*Maximum turning radius with 11R22.5 tires.

**Chassis Types**

- CT660S
- SBA ● 116 BBC ● 6x4
- Rear Tandem Axles Powered

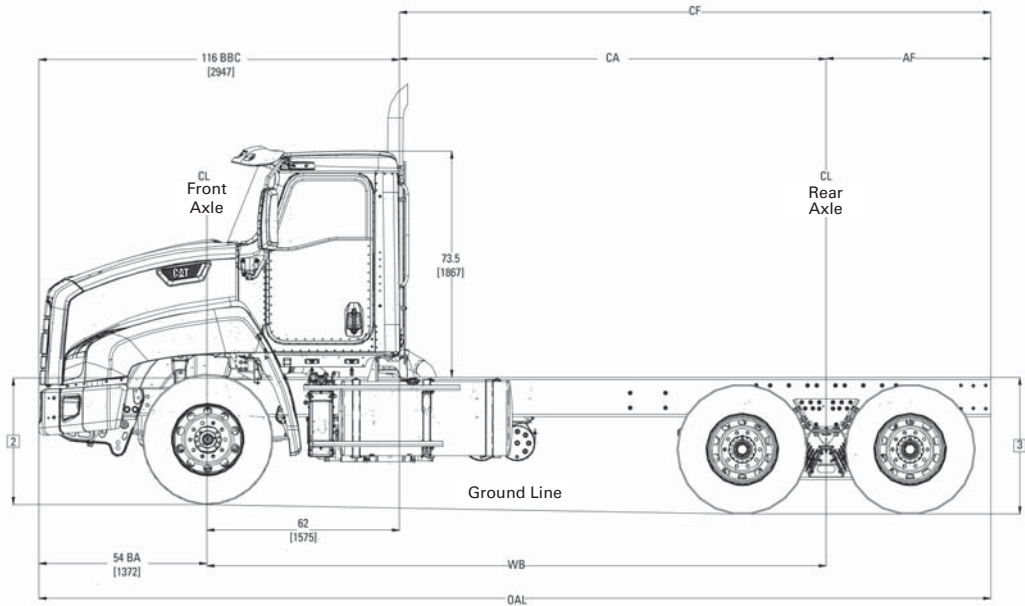

Wheelbase (in)	Chassis Weight (lb)*			Dimensions (in)				Turning Radius**
	Front	Rear	Total	CA	CF	AF	OAL	To Curb
163				101.4	154.5	53	270.6	21'4"
181				119.1	172.2	53	288.3	23'1"
199	9545	6674	16,219	136.8	190	53	306	24'11"
211				148.6	201.8	53	317.8	26'1"

\*Weight includes standard chassis, oil and water, less fuel.

\*\*Maximum turning radius with 11R22.5 tires.

# On-Highway Trucks

## Chassis Types

- CT660L
- SBA ● 122 BBC ● 6x4
- Rear Tandem Axles Powered

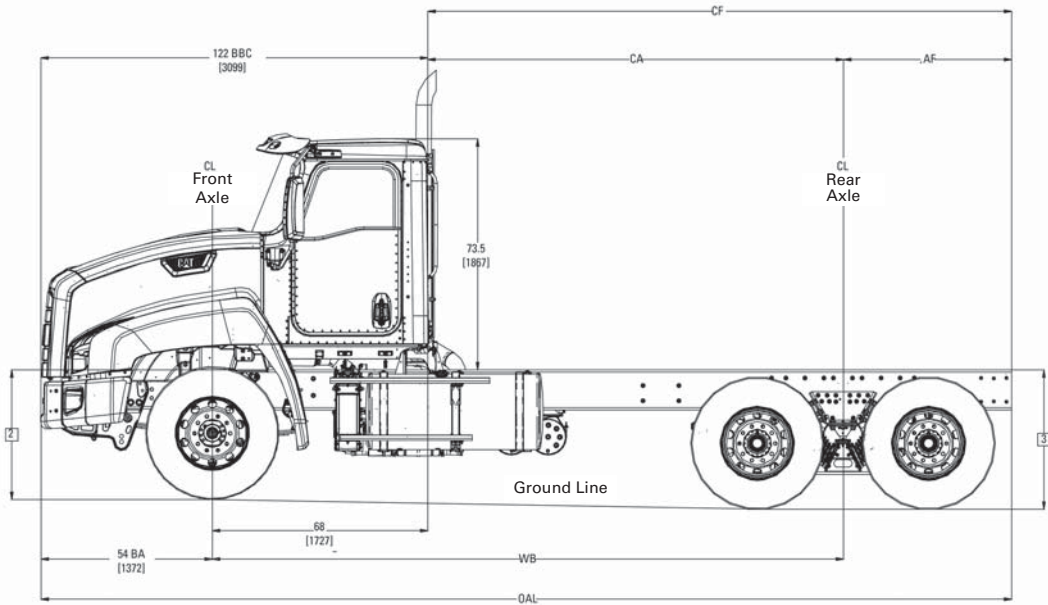

Wheelbase (in)	Chassis Weight (lb)*			Dimensions (in)				Turning Radius**
	Front	Rear	Total	CA	CF	AF	OAL	To Curb
163				95.4	148.4	53	270.4	21'4"
181				113.1	166.1	53	288.1	23'1"
199	9509	7028	16,537	130.8	183.8	53	305.8	24'11"
211				142.6	195.6	53	317.6	26'1"

\*Weight includes standard chassis, oil and water, less fuel.

\*\*Maximum turning radius with 11R22.5 tires.

**Chassis Types**

- CT660S
- SBA ● 116 BBC ● 8x6
- Rear Tridem Axle Powered

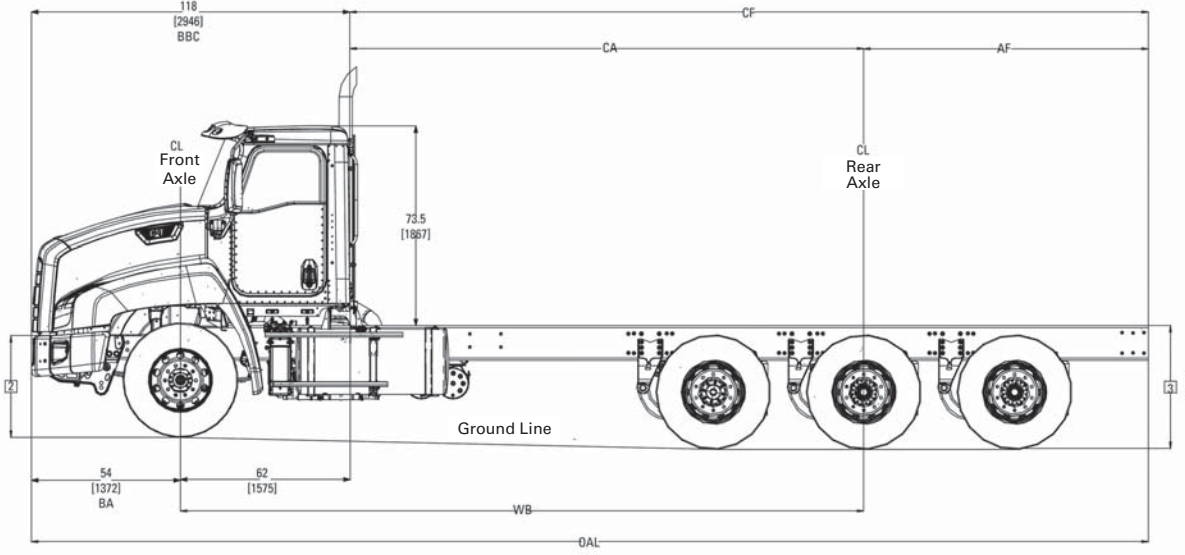

Wheelbase (in)	Chassis Weight (lb)*			Dimensions (in)				Turning Radius**
	Front	Rear	Total	CA	CF	AF	OAL	To Curb
250	10,176	9379	19,573	188	292	104	408	29'11"
252				190	294	104	410	30'1"
286				224	328	104	444	33'6"
321				258.9	363	104	479	37'1"

\*Weight includes standard chassis, oil and water, less fuel.  
 \*\*Maximum turning radius with 11R22.5 tires.

# On-Highway Trucks

## Chassis Types

- CT660L
- SBA ● 122 BBC ● 8x6
- Rear Tridem Axle Powered

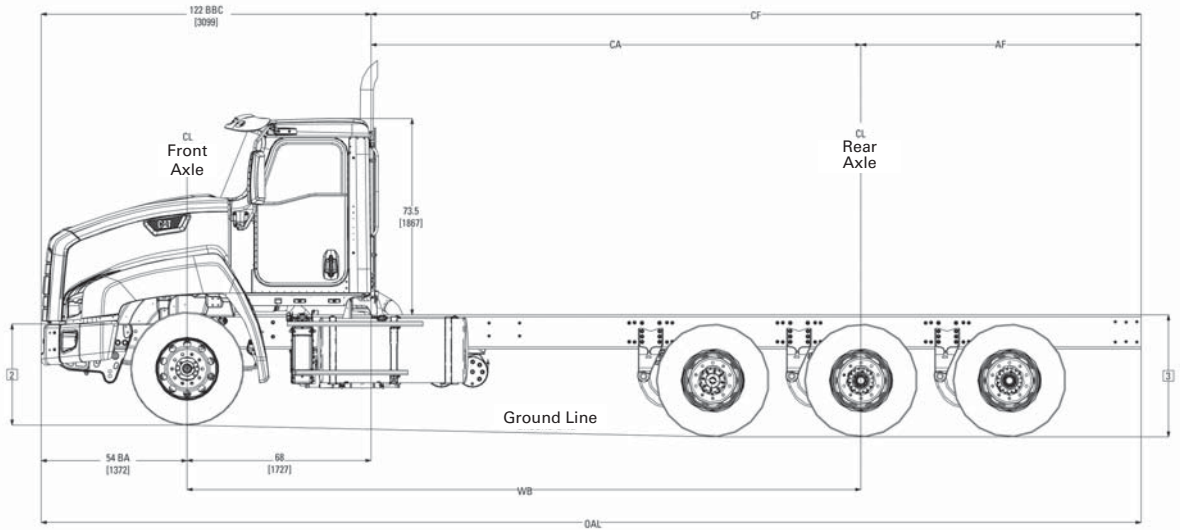

Wheelbase (in)	Chassis Weight (lb)*			Dimensions (in)				Turning Radius**
	Front	Rear	Total	CA	CF	AF	OAL	To Curb
250	9835	9774	19,609	182	286	104	408	29'11"
252				184	288	104	410	30'1"
286				218	322	104	444	33'6"
321				356.9	356.9	104	478.9	37'1"

\*Weight includes standard chassis, oil and water, less fuel.

\*\*Maximum turning radius with 11R22.5 tires.

Chassis Types

- CT681
- SFA ● 114 BBC ● 6x4
- Rear Tandem Axles Powered

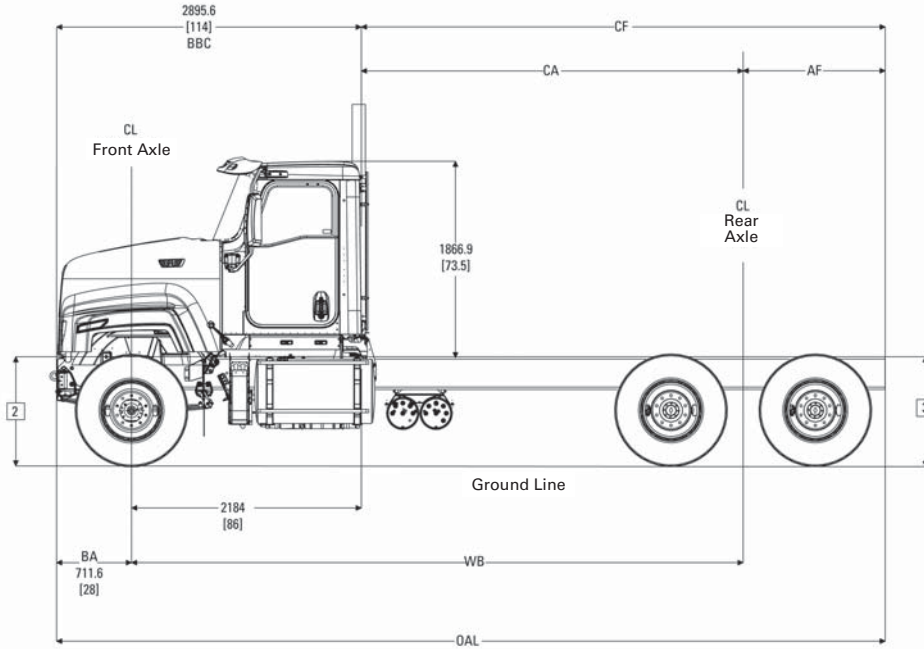

Wheelbase (in)	Chassis Weight (lb)*			Dimensions (in)				Turning Radius**
	Front	Rear	Total	CA	CF	AF	OAL	To Curb
188				102	156	54	270	30'0"
206				120	174	54	288	32'4"
224	7955	7082	15,037	138	192	54	306	34'7"
236				150	204	54	318	36'2"

\*Weight includes standard chassis, oil and water, less fuel.

\*\*Maximum turning radius with 11R22.5 tires.

# On-Highway Trucks

## Chassis Types

- CT680
- SFA ● 124 BBC ● 6x4
- Rear Tandem Axles Powered

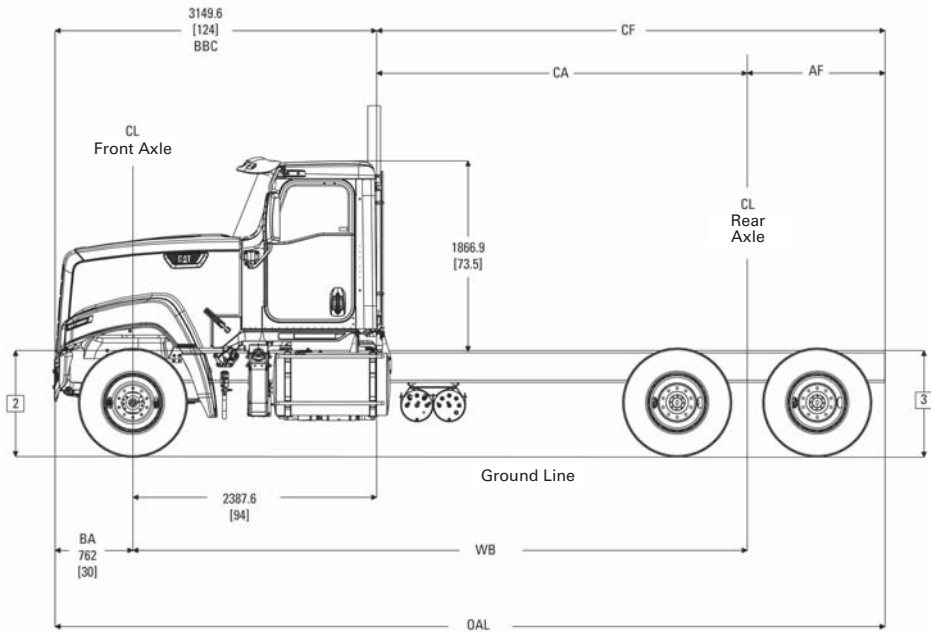

Wheelbase (in)	Chassis Weight (lb)*			Dimensions (in)				Turning Radius**
	Front	Rear	Total	CA	CF	AF	OAL	To Curb
192				102	156	54	276	30'6"
210				120	174	54	294	32'9"
228	8880	7609	16,489	138	192	54	312	35'1"
240				150	204	54	324	36'8"

\*Weight includes standard chassis, oil and water, less fuel.

\*\*Maximum turning radius with 11R22.5 tires.

Chassis Types

- CT680
- SFA ● 124 BBC ● 8x6
- Rear Tridem Axle Powered

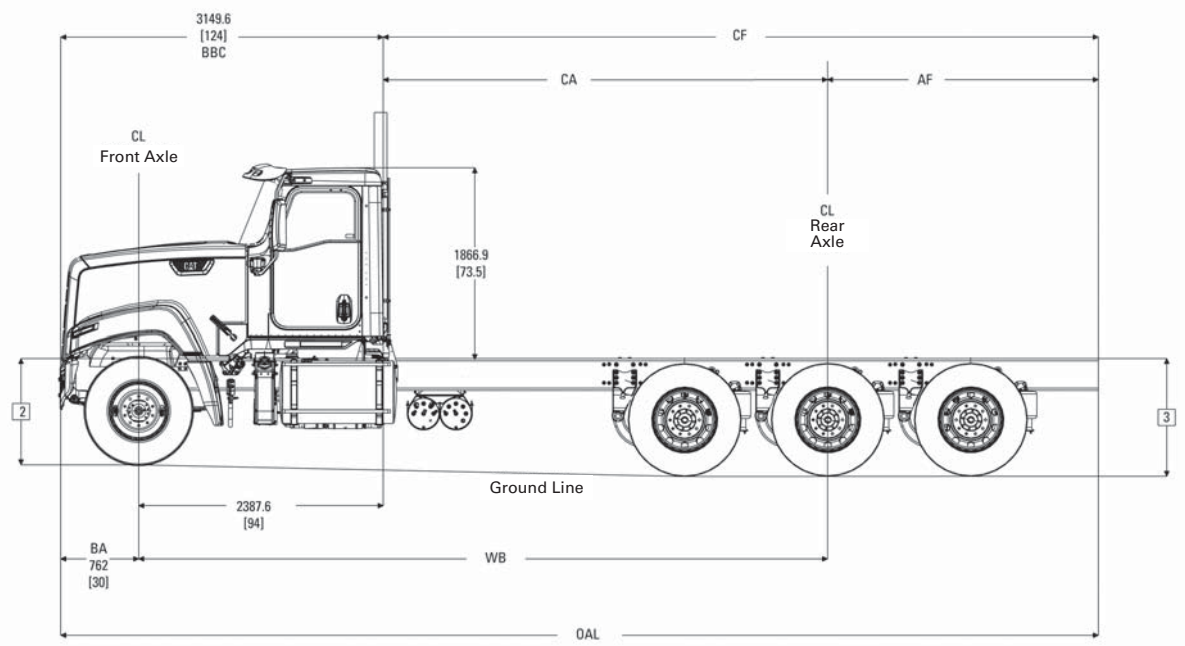

Wheelbase (in)	Chassis Weight (lb)*			Dimensions (in)				Turning Radius**
	Front	Rear	Total	CA	CF	AF	OAL	To Curb
192				102	156	54	276	30'6"
210				120	174	54	294	32'9"
228	8880	9209	18,089	138	192	54	312	35'1"
240				150	204	54	324	36'8"

\*Weight includes standard chassis, oil and water, less fuel.  
 \*\*Maximum turning radius with 11R22.5 tires.



**General Specifications**

Model	BBC	Chassis	Engine
CT660S SBA	116"	6x4, 8x6	13L
CT660L SBA	122"	4x4, 6x6	13L
CT680 SFA	124"	6x4, 8x6	13L
CT681 SFA	114"	6x4	13L

**Engine Specifications**

Engine	BHP/GT (lbf-ft)
CT13	365/1250; 370/1350; 390/1450; 410/1450; 430/1550; 475/1700

**NOTE:** CT681 available with Front Engine PTO.  
Gov. Speed RPM = 2100  
Available CT681 hp ranges: 365-430 hp

**Wheelbase**

Variable: 138" – 394"

**Transmission**

Cat CX31 Power Shift Automatic, (6 Fwd, 1 Rev) Speeds  
(2 PTO's Std.) Opt. Rear PTO  
Eaton Manual 10, 11, 13, 18 Speeds  
Eaton UltraShift PLUS Vocational 10, 13, 15, 18 Speeds

**Frame (120,000 psi steel)**

12.25 x 3.375 x 0.375	SM = 21	RBM = 2,520,000 lb
12.65 x 3.5 x 0.5	SM = 29	RBM = 3,458,580 lb
13.03 x 3.687 x 0.6880	SM = 40	RBM = 4,865,748 lb

**NOTE:** CT681 available with Integral Front Frame Extension.

**Axles (Meritor/Dana Spicer)**

13,200 lb – 23,000 lb Front  
40,000 lb – 70,000 lb Rear

**Suspension (Hendrickson, Chalmers, Neway)**

Front: Multi Leaf (Shackle or Slipper type)  
Front: Parabolic Taper Leaf  
Rear: Walking Beam, Air, Spring

**Brakes (Bendix and Meritor)**

ABS and ASA Standard  
Front Disc Brakes for Tractor 16K Axle and above  
Opt.: Traction and Stability Control

**Fuel Tanks**

60, 80, 100, 120 U.S. gal  
Polished/non polished aluminum  
Dual tanks optional

**GVWR**

Variable: Based on Frame, Wheelbase, Axles, Suspension,  
Brakes, Wheels, and Tires selected. Also, Federal  
and State Laws.

**Lift Axles (Watson and Chalin)**

6x4: CT660 and CT681  
Pusher Type: 8000 lb-20,000 lb  
Tag Type: 13,200 and 20,000 lb

**WEIGHT DISTRIBUTION**

The first step in spec'ing a Truck is to understand how the load is distributed on the Front and Rear Axles. The load is defined as the Maximum expected weight of a fully loaded Truck. That includes the Driver, Fuel, Fluids, Payload, and Truck Body. Once the axle loading is known, it's possible to begin selecting the Frame, Engine, Transmission, Axles, Suspension, Tires, etc.

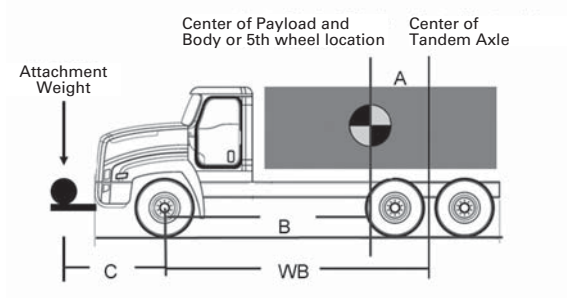

**Start** by identifying where (in relation to the axles) the load will come onto the truck. This can be a 5th wheel location, or the center of gravity of the Body and Payload (like a Dump Truck or Tanker). See above illustration.

**Axle Loading** can be found by adding up how major loads are distributed on each axle. Typical loads are the weight of the Truck Chassis, Body, Payload, or 5th wheel. Add up all the loads that apply for your Truck.

**Axle Loading Due to Truck Chassis**  
(see "Chassis Types" tables in this section)

Front Axle Load (Given by Caterpillar) = \_\_\_\_\_ lb

Rear Axle Load (Given by Caterpillar) = \_\_\_\_\_ lb

**Axle Loading Due to Body and Payload**  
(omit if using a 5th wheel)

Front Axle Load = (Body + Payload weight) × (A/WB)  
= \_\_\_\_\_ lb

Rear Axle Load = (Body + Payload weight) × (B/WB)  
= \_\_\_\_\_ lb

**Axle Loading Due to 5th Wheel**  
(omit if using a Body)

Front Axle Load = 5th Wheel Load × (A/WB)  
= \_\_\_\_\_ lb

Rear Axle Load = 5th Wheel Load × (B/WB)  
= \_\_\_\_\_ lb

**Axle Loading Due to Forward Mounted Loads**  
(Winches, Plows, etc.)

Front Axle Load = Attachment weight × (C + WB)/WB = \_\_\_\_\_ lb

Rear Axle Load = - Attachment weight × (C/WB) =  
- \_\_\_\_\_ lb Negative

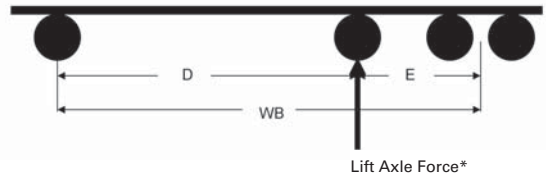

\*Max Lift Force = Lift Axle (Rated Capacity) – Weight of the Lift Axle.

Example:

Max lift force for a 13,200 lb lift axle is approximately 12,000 lb. The remaining 1200 lb is the weight of the axle, tires, wheels, and brakes.

**Axle Loading Due to Lift Axles\***  
(see above illustration)

Front Axle Load = - Lift Axle Force × (E/WB) =  
- \_\_\_\_\_ lb Negative

Rear Axle Load = - Lift Axle Force × (D/WB) =  
- \_\_\_\_\_ lb Negative

\*If more than one (1) lift axle repeat as required.

**Total Axle Loading**

Front Axle Load = Add all Front loads that apply =  
\_\_\_\_\_ lb

Rear Axle Load = Add all Rear loads that apply =  
\_\_\_\_\_ lb

**GVWR AND GCWR**

**GVWR** = Gross Vehicle Weight Rating. This rating is used for a Straight Truck.

**GCWR** = Gross Combination Weight Rating. This rating is used for Tractors with 5th wheels.

**Procedure to Determine GVWR or GCWR**

- 1) Determine the maximum expected load on each axle (see Weight Distribution section).
- 2) Select Axles, Suspensions, Brakes, Wheels and Tires that are sized to take the load predicted by the Weight Distribution Study. All components must be rated equal to or greater than the expected axle loading. See Appendix D, E, F, H, I, J, K, and L for component ratings.
- 3) The lowest rated component for each axle (including the axle), is the Maximum **Axle Rating** for that axle.

**GVWR** = Front + Rear + Lift (Axle Rating for each axle)

**GCWR** = Front + Rear + Lift + Trailer (Axle Rating for each axle)

**Example: Front Axle Rating**

Expected Front Axle Load	12,420 lb
Axle rated for	13,200 lb
Suspension rated for	14,000 lb
Wheels rated for	14,000 lb
Tires rated for	13,800 lb
Brakes rated for	14,000 lb

In this example the front axle is the lowest rated component that will carry the load predicted by the Weight Distribution Study. Thus, the Front **Axle Rating** is 13,200 lb in this example.

**Bridge Laws**

Careful attention must be given to laws governing overall weight, maximum axle loading, and axle spacing. These laws are commonly referred to as Bridge Laws, and are different in every State, Region, or Province. This handbook does not cover these laws. The reader is advised to refer to their local Bridge Law formulas.

### FRAME SELECTION GUIDE FOR CT660

Based on Front Axle Load, Desired GVWR and Wheelbase: Select a Frame from table below. Frame length varies in roughly two inch increments to accommodate many different body sizes. Frames can also be Reinforced (or Doubled) to carry heavier loads.

	Dimensions	Code	Front Axles	GVWR	Maximum Wheelbase															
					200	210	220	230	240	250	260	270	280	290	300	310	320	330	340	350
Not Reinforced	12.25 x 3.375 x 0.375	01CDH	12K	<=52K	331" (8400 mm)															
			13.2K	<=53.2K	329" (8350 mm)															
			14-14.6K	<=60.6K	280" (7100 mm)															
			16K	<=62K	260" (6600 mm)															
			18K	<=64K	246" (6250 mm)															
			20K	<=85K					234" (5950 mm)											
			21-22K	<=87K					222" (5650 mm)											
			23K	<=88K	215" (5450 mm)															
Reinforced	12.0 x 3.25 x 0.25 with 0.25 Outer Reinforcement	01DAV	12K	<=52K												360" (9150 mm)				
			13.2K	<=53.2K												360" (9150 mm)				
			14-14.6K	<=60.6K												358" (9100 mm)				
		01GDL	16K	<=62K	325" (8250 mm)															
			18K	<=64K	299" (7600 mm)															
			20K	<=98K	293" (7450 mm)															
			21-22K	<=100K	276" (7000 mm)															
	23K	<=101K	266" (6750 mm)																	
Reinforced	12.25 x 3.375 x 0.375	01CDH	12K	<=52K												360" (9150 mm)				
			13.2K	<=53.2K												360" (9150 mm)				
			14-14.6K	<=60.6K												360" (9150 mm)				
	01GDM	16K	<=62K												360" (9150 mm)					
		18K	<=64K	352" (8950 mm)																
		20K	<=98K	317" (8050 mm)																
		21-22K	<=100K	309" (7850 mm)																
	23K	<=101K	301" (7650 mm)																	

**FRAME SELECTION GUIDE  
FOR CT680 AND CT681**

Based on Front Axle Load, Desired GVWR and Wheelbase: Select a Frame from table below. Frame length varies in roughly two inch increments to accommodate many different body sizes. Frames can also be Reinforced (or Doubled) to carry heavier loads.

Dimensions	Code	Front Axles	GVWR	Maximum Wheelbase																
				200	210	220	230	240	250	260	270	280	290	300	310	320	330	340	350	360
12.25 x 3.375 x 0.375	01CDH	12K	<=52K	299" (7600 mm)																
		13.2K	<=53.2K	274" (6950 mm)																
		14K	<=60K	258" (6550 mm)																
		16K	<=62K	258" (6550 mm)																
		18K	<=64K	254" (6450 mm)																
		20K	<=66K	254" (6450 mm)																
		20K	<=85K	205" (5200 mm)																
12.0 x 3.25 x 0.25  with 0.25 Outer Reinforcement	01DAV 01GDL	12K	<=52K	360" (9150 mm)																
		13.2K	<=53.2K	337" (8550 mm)																
		14K	<=60K	329" (8350 mm)																
		16K	<=62K	299" (7600 mm)																
		18K	<=64K	283" (7200 mm)																
		20K	<=66K	283" (7200 mm)																
		20K	<=85K	270" (6850 mm)																
12.25 x 3.375 x 0.375  with 0.312 Outer Reinforcement	01CDH 01GDM	12K	<=52K	360" (9150 mm)																
		13.2K	<=53.2K	360" (9150 mm)																
		14K	<=60K	360" (9150 mm)																
		16K	<=62K	348" (8850 mm)																
		18K	<=64K	339" (8600 mm)																
		20K	<=66K	319" (8100 mm)																
		20K	<=85K	295" (7500 mm)																

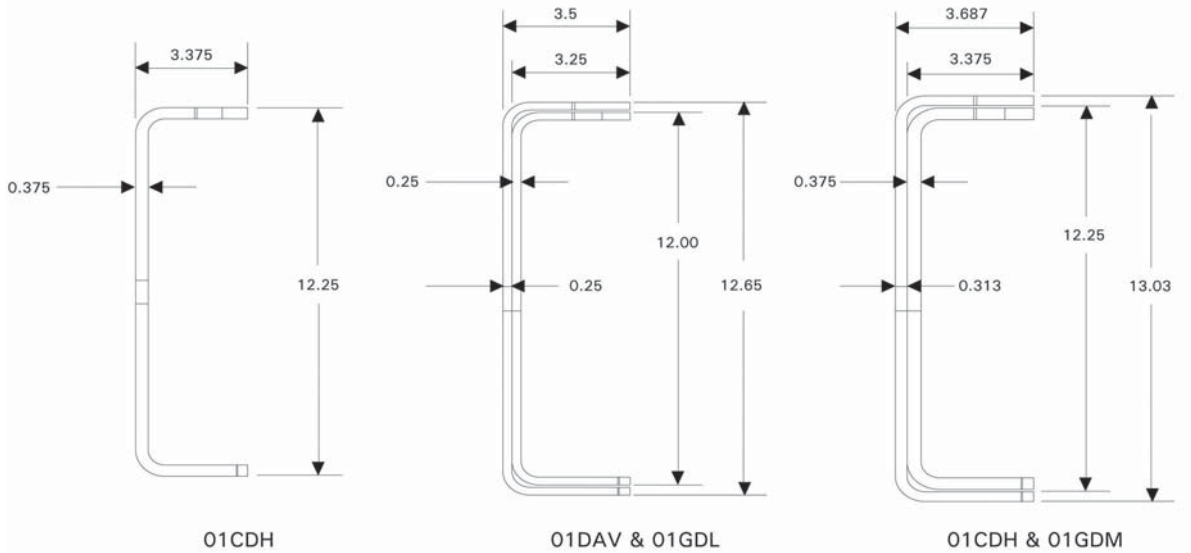

**Standard Frame Not Reinforced**

**SM = 21 in<sup>3</sup>**

**RBM = 2,520,000 lb**

**Optional Reinforced Frame**

**SM = 28.82 in<sup>3</sup>**

**RBM = 3,458,580 lb**

**Optional Reinforced Frame**

**SM = 40.45 in<sup>3</sup>**

**RBM = 4,865,748 lb**

SM = Section Modulus is based on the cross sectional area of the frame and its distance from the neutral axis of bending.

RBM = Resistance to Bending Moment = SM × Steel Strength = SM × 120,000 psi for All Cat Frames.

**SELECTING GEAR RATIOS FOR TRANSMISSION AND AXLES**

**Select the Desired Axle Ratio (AR)**

$$AR = \frac{RPM \text{ (at cruise)} \times 60}{TR \times MPH \times M \times ATR \times DBR}$$

**NOTE:** This equation provides the Theoretical axle ratio. Select the closest axle ratio found in Appendix E.

RPM = Engine RPM at desired cruise. See table below or Torque Curves in Appendix C.

TR = Transmission ratio (Top gear). See Appendix D.

MPH = Desired cruise speed (not maximum speed).

M = Tire revolutions per mile. See Appendix I.

ATR = Auxiliary Transmission ratio. See Appendix D.

DBR = Drop Box Ratio. See Appendix D (omit if 1:1).

60 = Constant.

**Suggested Cruise Speeds**

Engine Family	Application	Engine Speed for Fuel Economy	Engine Speed for Performance	Vehicle Cruise Speed
CT13	Vocational	1375-1500	1500-1650	55
CT13	Extended Highway	1325-1375	1375-1450	65

**Select the Desired Transmission Ratio (TR) Top Gear/Overdrive**

$$TR = \frac{RPM \text{ (at cruise)} \times 60}{AR \times MPH \times M \times ATR \times DBR}$$

**NOTE:** For AR, use the Axle ratio selected from Appendix E.

**NOTE:** This equation provides the Theoretical Transmission ratio. Select the closest actual gear ratio from Appendix D.

**Verify Cruise and Maximum Speed**

Use the actual Transmission and Axle ratios you selected from Appendix D and E to verify the desired cruise and Maximum speed. Do not use the theoretical values. If you're within 5 mph of your desired cruise speed that is a good gearing combination. Otherwise, modify your choices for the Axle or Transmission Ratios to get closer. It may take a few attempts to meet your requirements.

$$MPH \text{ (cruise)} = \frac{RPM \text{ (at cruise)} \times 60}{AR \times TR \times M \times ATR \times DBR}$$

$$MPH \text{ (Max)} = \frac{2100 \text{ (max RPM)} \times 60}{AR \times TR \times M \times ATR \times DBR}$$

**NOTE:** Use the actual AR and TR selected from Appendix D and E for MPH (cruise) and MPH (Max).

**ENGINE SELECTION**

There are many factors that dictate the correct engine size for a specific application. It’s possible to use a mathematical approach to add up all the horsepower demands to size the engine. However, it’s also important to understand the application and driver habits. In addition, understand how the customer’s other trucks are configured. This critical customer knowledge is used to verify or modify the results of the mathematical approach to achieve the best engine selection for the application.

**Mathematical Approach Overview:** 3 step process.

- 1) Add up all the HP loads at vehicle cruise speed. Examples of HP demands are: Rolling Resistance, Drag, Slopes, Road Surface, Driveline Losses, Accessories, and Power Takeoffs.
- 2) Determine the Torque required to start fully loaded on the customer’s maximum grade. This is called (Startability).
- 3) Use your knowledge of the application to verify if the Engine selected in steps 1 and 2 makes sense.

**Step 1 Calculations:** Add up the HP required at the expected vehicle cruise speed.

**NOTE:** All the following formulas can be programmed into a Spread Sheet for faster evaluation.

**Rolling Resistance:** The HP required on a flat surface to overcome Tire Squat. Since tires are not perfectly round, (especially when loaded) the Truck is climbing a small slope just to move forward.

$$Pr = \frac{(6.1 + (0.06 \times MPH)) \times Cp \times GW \times MPH}{375,000}$$

Cp = Tire Pavement Factors. See table below.

GW = Gross Vehicle Weight or Gross Combination Weight required for the application.

6.1 = Constant.

0.06 = Constant.

375,000 = Constant.

MPH = Desired Cruise Speed (not maximum speed).

**Tire Pavement Factors**

Surface	Bias	Radial	LP Radial	Wide Base
Concrete	1.00	0.70	0.63	0.50
Cold Blacktop	1.20	0.85	0.70	0.60
Hot Blacktop	1.50	0.90	0.83	0.70
Hard Soil	1.75	1.00	0.98	0.85
Hard Gravel	2.00	1.20	1.13	1.00
Loose Gravel	7.50	1.70	1.63	1.50
Sand	12.00			



**Air Resistance:** The HP required to overcome wind resistance. This starts becoming significant above 30 MPH. Over 65 MPH it can be the largest single load.

$$Pa = \frac{FA \times Cd \times MPH^3}{156,000}$$

Cd = Aerodynamic Drag Coefficient. See table below.

FA = Frontal Area of the Truck (sq ft) + Area of the body or trailer that is wider or taller than the Truck. If the trailer is more than eight feet behind the Truck, FA = the Frontal Area of the Truck + the Total Frontal area of the Trailer. See illustration below.

156,000 = Constant.

MPH = Desired Cruise Speed (not maximum speed).

**Aerodynamic Drag Coefficients**

Configuration	Factor
HD Tractor – Full Aero/Van Trailer Full Aero	0.42
HD Tractor – Full Aero/Van Trailer Typical	0.48
MD Van Truck – Full Aero	0.50
HD Tractor – Full Aero/Van Trailer some Aero	0.54
HD Tractor – Full Aero/Tank Trailer Insulated	0.55
HD Tractor – Full Aero/Flat Trailer some Aero (Smooth Load)	0.55
HD Tractor – Full Aero/Van Trailer no Aero	0.80
HD Tractor – Full Aero/Flat Trailer some Aero (Rough Load)	0.80
HD Tractor – Full Aero/Tank Trailer Non Insulated	0.80
HD Tractor – No Aero/Van Trailer no Aero	0.80
MD Van Truck – No Aero	0.80
HD Dump	0.90
MD Dump – No Aero	0.90
HD Tractor – Car Hauler	1.00
HD Tractor – No Aero/Flat Trailer some Aero	1.00

Aero refers to side panels and deflectors to make the Truck more aerodynamic.

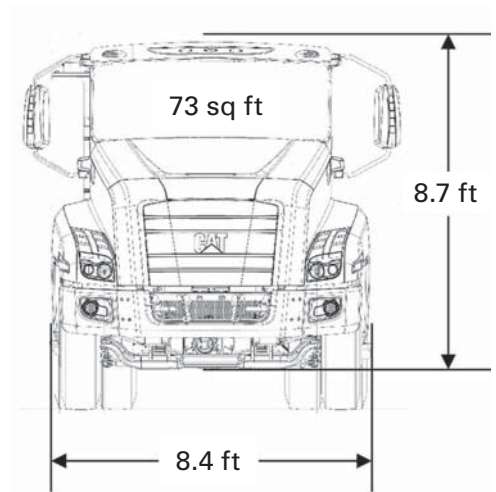

**CT660**

**Gradeability:** The reserve HP required to operate indefinitely (without downshifting) at the desired cruise speed on a small grade between 0.5% – 1% Grade.

$$Pg = \frac{G \times GW \times MPH}{37,500}$$

G = Grade Percent (Typically 0.5 or 1).

GW = Desired Gross Vehicle Weight or Gross Combination Weight.

37,500 = Constant.

MPH = Desired Cruise Speed (not maximum speed).

**Accessories:** The HP required to power the Cooling Fan, Alternator, Power Steering, A/C and Air Compressor at the desired cruise speed.

$$P_{acc} = 57 \text{ HP @ 1600 RPM} = 73 \text{ HP at 1800 RPM}$$

Considering 2100 is Max Engine RPM. Select a Pacc that best matches your application.

**PTO:** The HP required to power Mixers, Pumps, Generators, etc. that are running while the truck is cruising.

$$P_{pto} = \text{Supplied by Body Builder}$$

Zero if not running while cruising

**Total HP Required at the Drive Wheel**

$$P_{req} = P_r + P_a + P_g + P_{acc} + P_{pto}$$

**Engine Selection:** Account for Driveline losses and select an Engine with at least as much HP as P(eng) from table below. Continue to Step 2, to verify the Engine you selected has the required Torque.

$$P_{eng} = \frac{P_{req}}{0.93}$$

0.93 = Driveline Efficiency

**Engine Specifications**

Engine	Horsepower (BHP @ 1700 RPM)	Torque Peak (lbf-ft @ 1000 RPM)	Gov. Speed (RPM)	Fully Developed Torque (lbf-ft at 800 RPM)
CT13	365	1250	2100	686
CT13	370	1350	2100	770
CT13	390	1450	2100	811
CT13	410	1450	2100	828
CT13	430	1550	2100	868
CT13	475	1700	2100	959

**Step 2A:** (Manual and Automated Manual Transmissions) Verify the Engine selected in Step 1 can get the Truck moving on the customer’s maximum grade.

**Startability:** Is the ability of the truck to start moving on the steepest grade the driver will face. The equation below (S) calculates the **Theoretical** Maximum Percent grade for the Engine you selected in Step 1. To more accurately predict Startability, ground conditions must be considered. Subtract the effects of ground conditions from (S) to determine the Maximum Predicted Startability.

$$S = \frac{(Tc \times R \times M)}{(10.7 \times GW)}$$

Tc = Fully Developed Torque (from Engine selected in Step 1). See Engine Specification table.

R = The overall Driveline gear ratio.

$\frac{\text{Transmission (low gear)} \times \text{Axle} \times \text{Aux Trans} \times \text{Drop box}}{\text{Omit Aux Trans and Drop Box ratios if not used}}$

M = Tire Revolutions per mile. See Appendix I.

GW = Desired Gross Vehicle Weight or Gross Combination Weight.

10.7 = Constant.

**Ground Conditions:** See Tire Pavement Factors table or Subtract 6% for every inch of tire penetration.

**Maximum Predicted Startability**

= S – Ground Conditions

Startability must be equal to or greater than the customer’s maximum percent grade. If below Maximum, Select an Engine of equal or greater HP with Higher Fully Developed Torque from Engine Specifications table. Rerun the Startability calculations to verify. Continue to Step 3 for final Engine selection.

**Step 2B:** (CX31 Automatic Transmission) Verify the Engine selected in Step 1 can get the Truck moving on the customer’s maximum grade.

**Startability:** Is the ability of the truck to Start moving on the steepest grade the driver will face. For an Automatic Transmission a simple equation cannot be used to predict Startability. For the CX31, see the Startability chart in Appendix G. It assumes starting on the best concrete. To more accurately predict Startability, ground conditions must be considered. Subtract the effects of ground conditions from (S) to determine the Maximum Predicted Startability.

S = See Appendix G

**Ground Conditions:** See Tire Pavement Factors table or Subtract 6% for every inch of tire penetration.

**Maximum Predicted Startability**

= S – Ground Conditions

Startability must be equal to or greater than the customer’s maximum percent grade. If below Maximum, Select an Engine with equal or greater HP and Higher Fully Developed Torque from Engine Specifications table. Rerun the Startability calculations to verify.

**Step 3: Final Engine Selection.** In Steps 1 and 2 you selected an Engine that had enough HP to maintain cruise speed and start on the maximum grade. Before making the final Engine selection, factor in application and driver habits. For example, additional Torque may be required in mountainous regions. Perhaps a smaller Engine can be used to save fuel if the driveline gearing is modified.

## DRIVELINE BRAKING

Driveline Braking is used to augment the main service brake system. A technology called Engine Compression Braking allows the engine to remove horsepower from the driveline by compressing air. In addition to providing additional stopping power, driveline braking also reduces maintenance costs by prolonging the life of brake linings. This technology is often referred to in the industry as a “Jake Brake.”

**NOTE:** Engine Compression Braking is recommended for all CT660 driveline braking applications.

### Engine Compression Brake HP vs. Engine RPM

Engine RPM	CT13		
	Level 1	Level 2	Level 3
1100	37	73	110
1300	57	113	170
1600	80	160	240
1700	110	220	330
1900	138	277	415
2100	157	313	470

### Driver Selectable Engine Compression Brake Levels

**NOTE:** The driver can select levels 1-3 at anytime with a 3 way toggle switch, even during braking.

An alternate Driveline Braking option is a Transmission Retarder. This is an option within the Cat CX31 automatic Transmission. It cannot be used in conjunction with Engine Compression Braking because of driveline overload.

Engine RPM	Braking HP
900	100
1000	133
1100	164
1200	210
1300	265
1400	298
1500	335
1600	414
1700	550
1800	583
1900	615
2000	647
2100	680

Reference Equations (English Units)

$$\text{MPH} = \frac{60 \times \text{RPM}}{\text{M} \times \text{Ra} \times \text{Rt}} \qquad \text{*Miles per Hour}$$

$$\text{M} = \frac{60 \times \text{RPM}}{\text{Ra} \times \text{Rt} \times \text{MPH}} \qquad \text{*Tire Revolutions per Mile}$$

$$\text{Ra} = \frac{60 \times \text{RPM}}{\text{M} \times \text{Rt} \times \text{MPH}} \qquad \text{*Rear Axle Ratio}$$

$$\text{Rt} = \frac{60 \times \text{RPM}}{\text{M} \times \text{Ra} \times \text{MPH}} \qquad \text{*Transmission Gear Ratio (Top Gear)}$$

$$\text{RPM} = \frac{\text{MPH} \times \text{M} \times \text{Ra} \times \text{Rt}}{60} \qquad \text{*Revolutions per Minute (Engine)}$$

$$\text{Torque} = \frac{\text{HP} \times 5252}{\text{RPM}} \qquad \text{Torque in lbf-ft}$$

$$\text{Horsepower} = \frac{\text{Torque} \times \text{RPM}}{5252} \qquad \text{Horsepower in lbf-ft per Second}$$

\*No Drop Box or Auxiliary Transmission.

● Vehicle Identification Number (VIN Structure)

**Vehicle Identification Number (VIN Structure)**

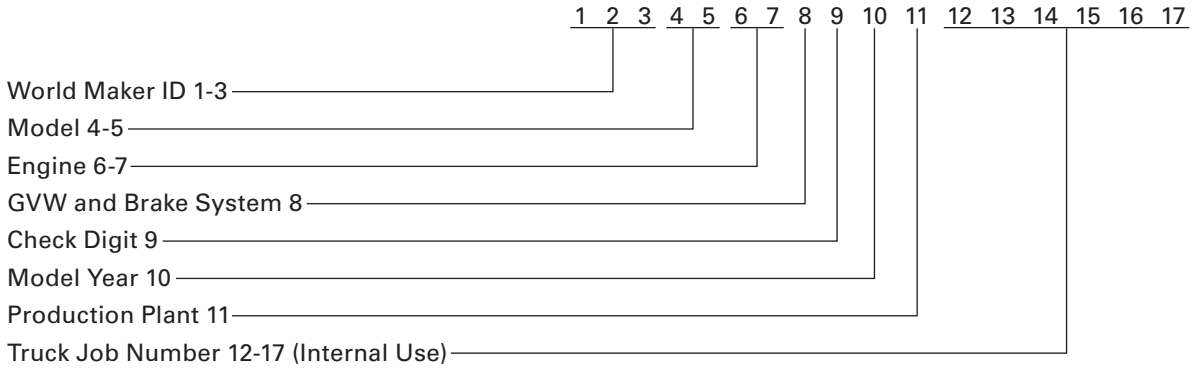

**World Maker ID 1-3**

- 3HP = Complete Truck
- 3HS = Complete Tractor
- 3HT = Incomplete Truck (Needs Body)

**Model 4-5**

- JG = CT660 6x4 112 BBC
- JK = CT660 6x4 122 BBC
- JN = CT660 4x4 122 BBC
- JP = CT660 6x6 122 BBC
- JH = CT660 8x6 112 BBC
- JL = CT660 8x6 122 BBC
- KB = CT680 6X4 124 BBC
- KA = CT681 6x4 114 BBC

**Engine Size 6-7**

CT13: TK

**Position 8**

GVW Range  
 33,001 to 55,000 = R  
 55,001 and Over = T

**Model Year 10**

- B = 2011    F = 2015
- C = 2012    G = 2016
- D = 2013    H = 2017
- E = 2014    I = 2018

**Production Facility 11**

N = Escobedo Mexico

**Example**

3HTKATKT8EN021730

An Incomplete Truck needing a body, CT681 model, CT13 Engine, GVWR over 55,000 lb, 2014 Model Year, Made in Mexico

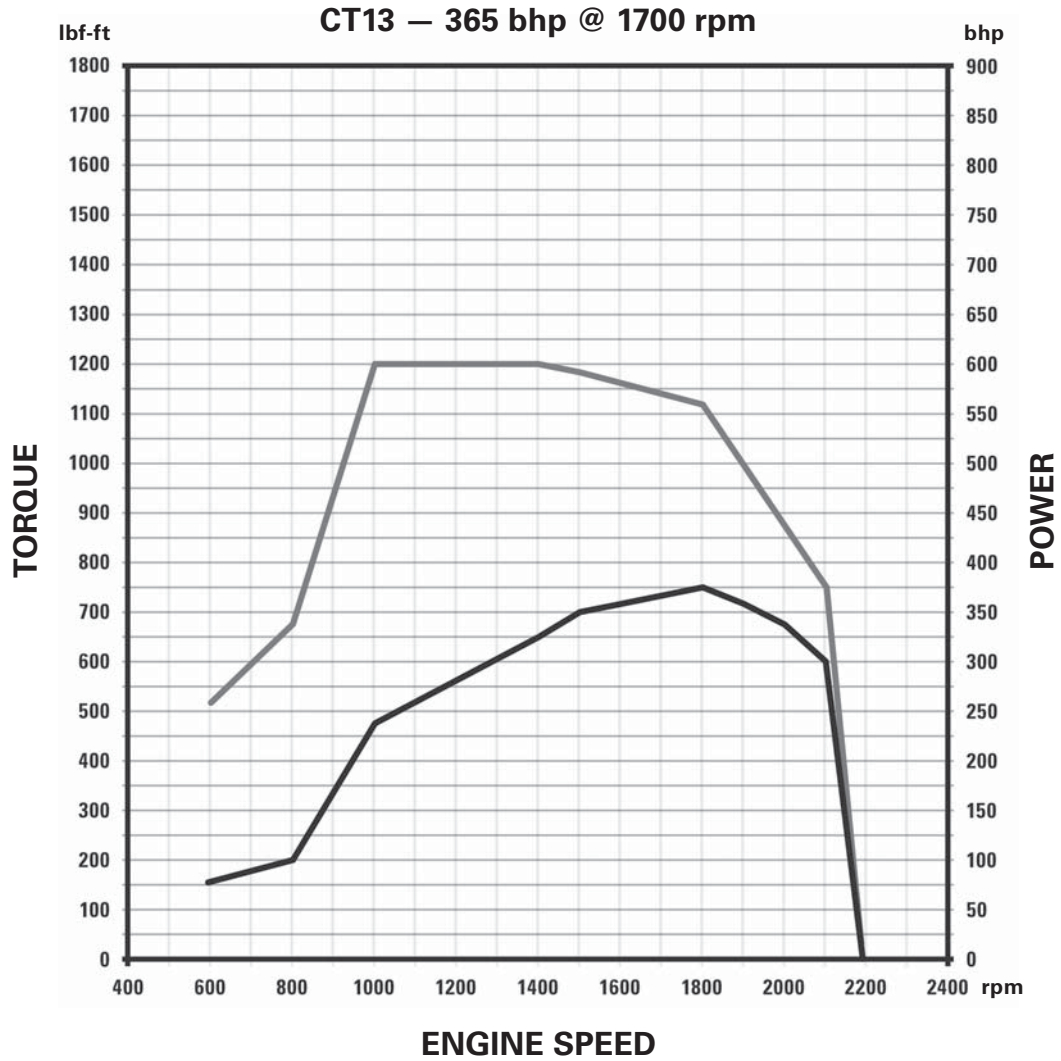

KEY  
— Torque  
— Power

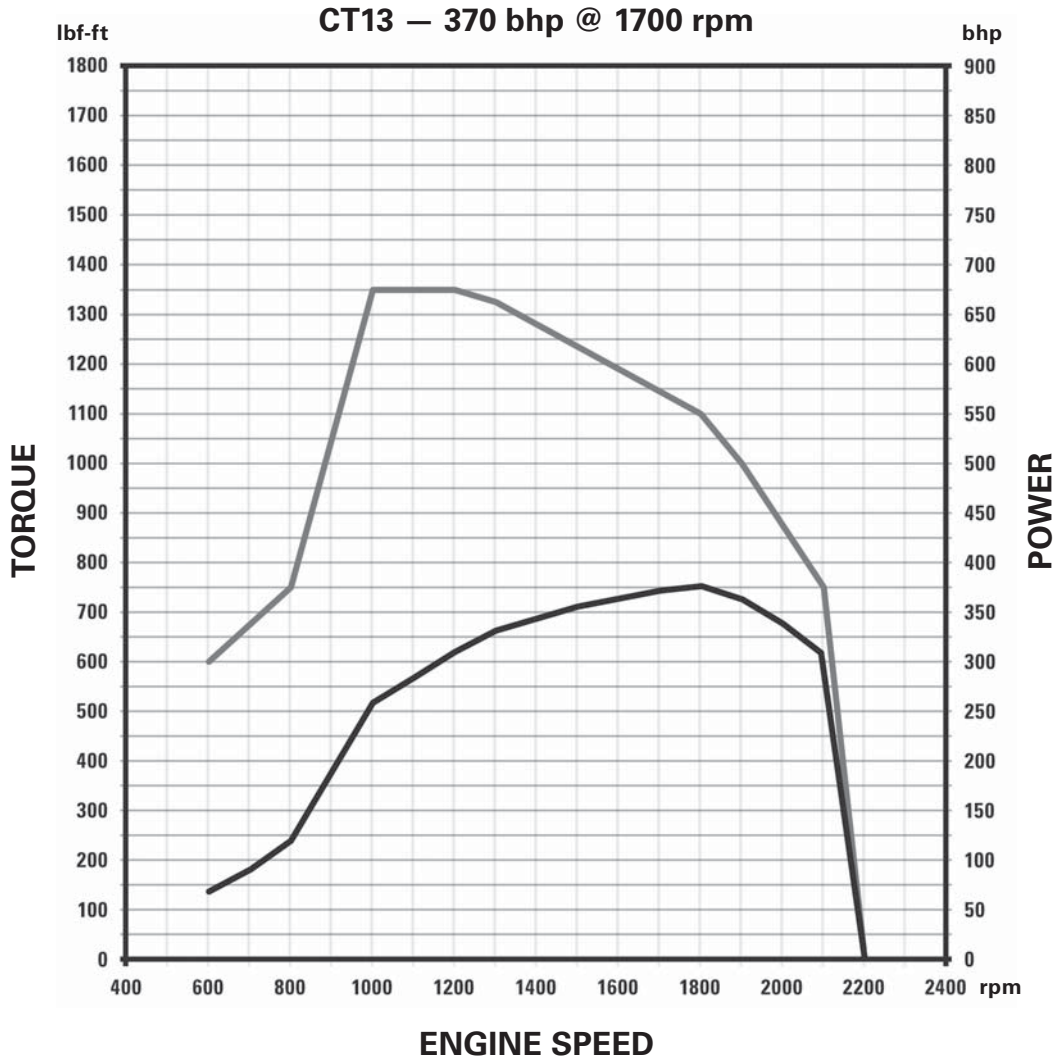

KEY  
— Torque  
— Power



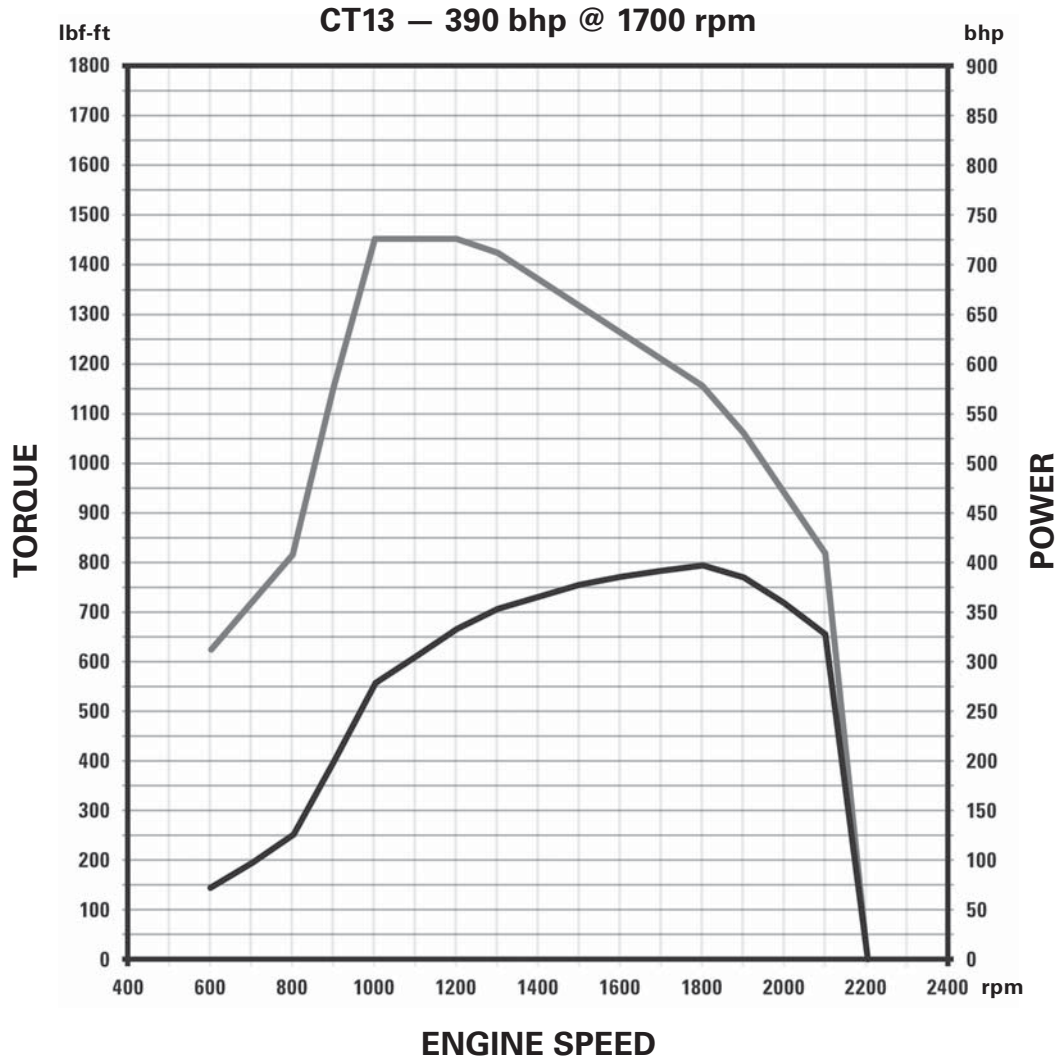

KEY  
— Torque  
— Power

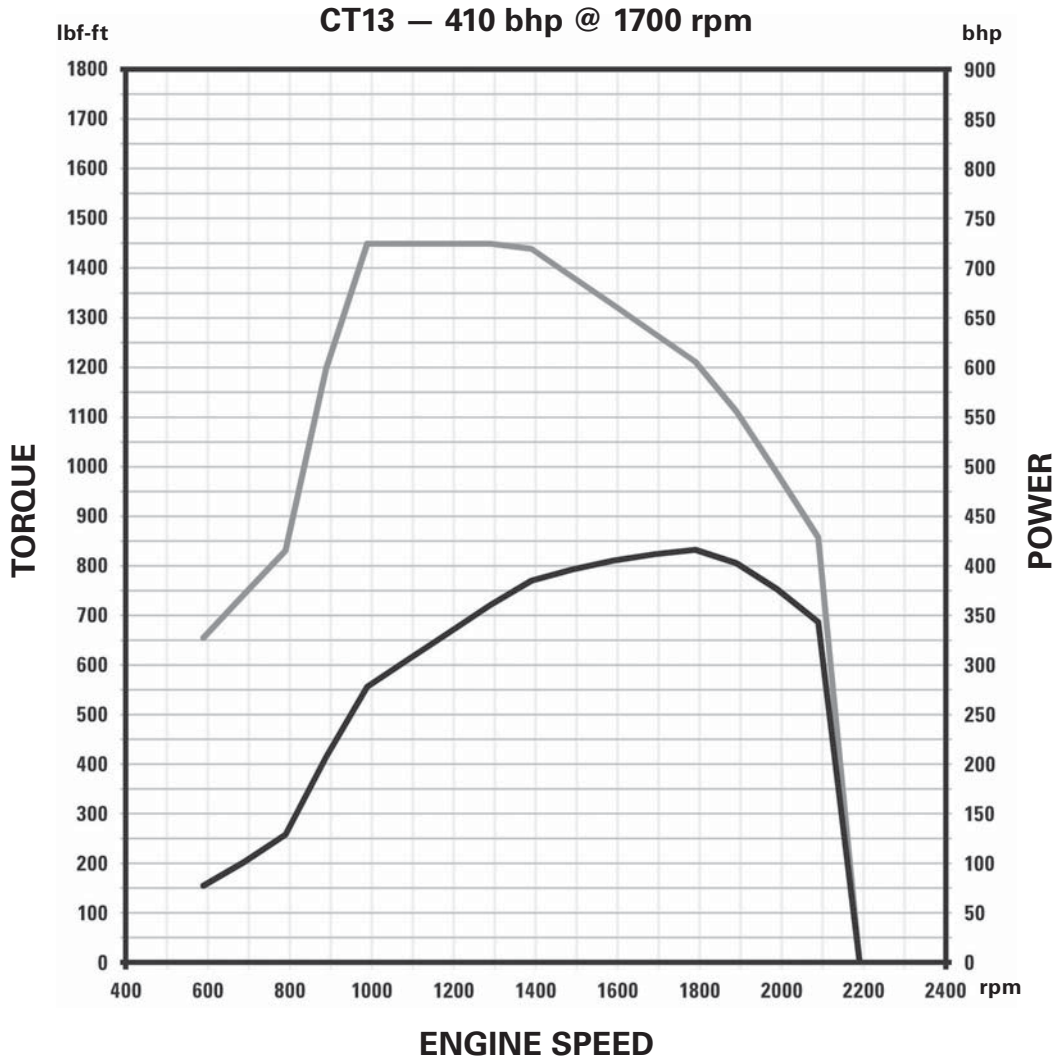

KEY  
— Torque  
— Power

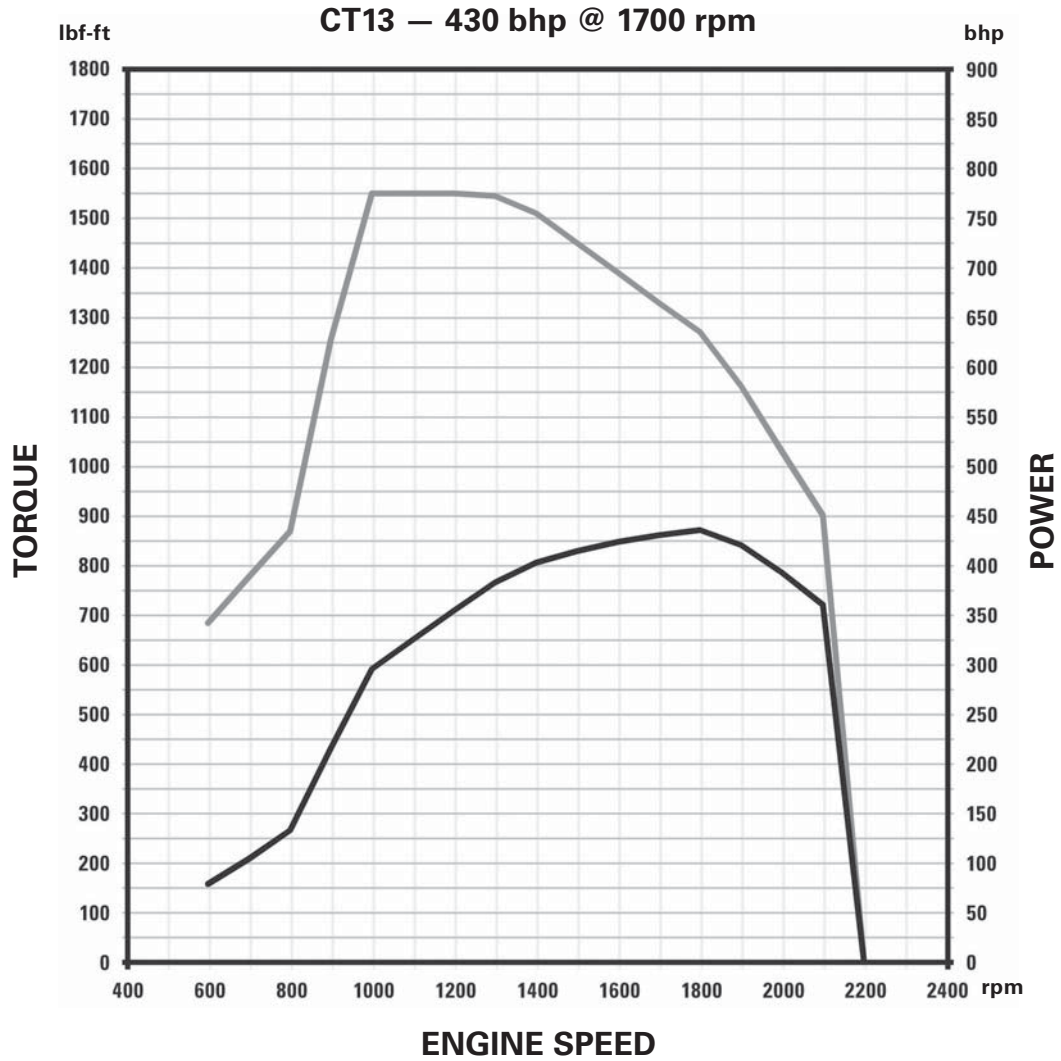

KEY  
— Torque  
— Power

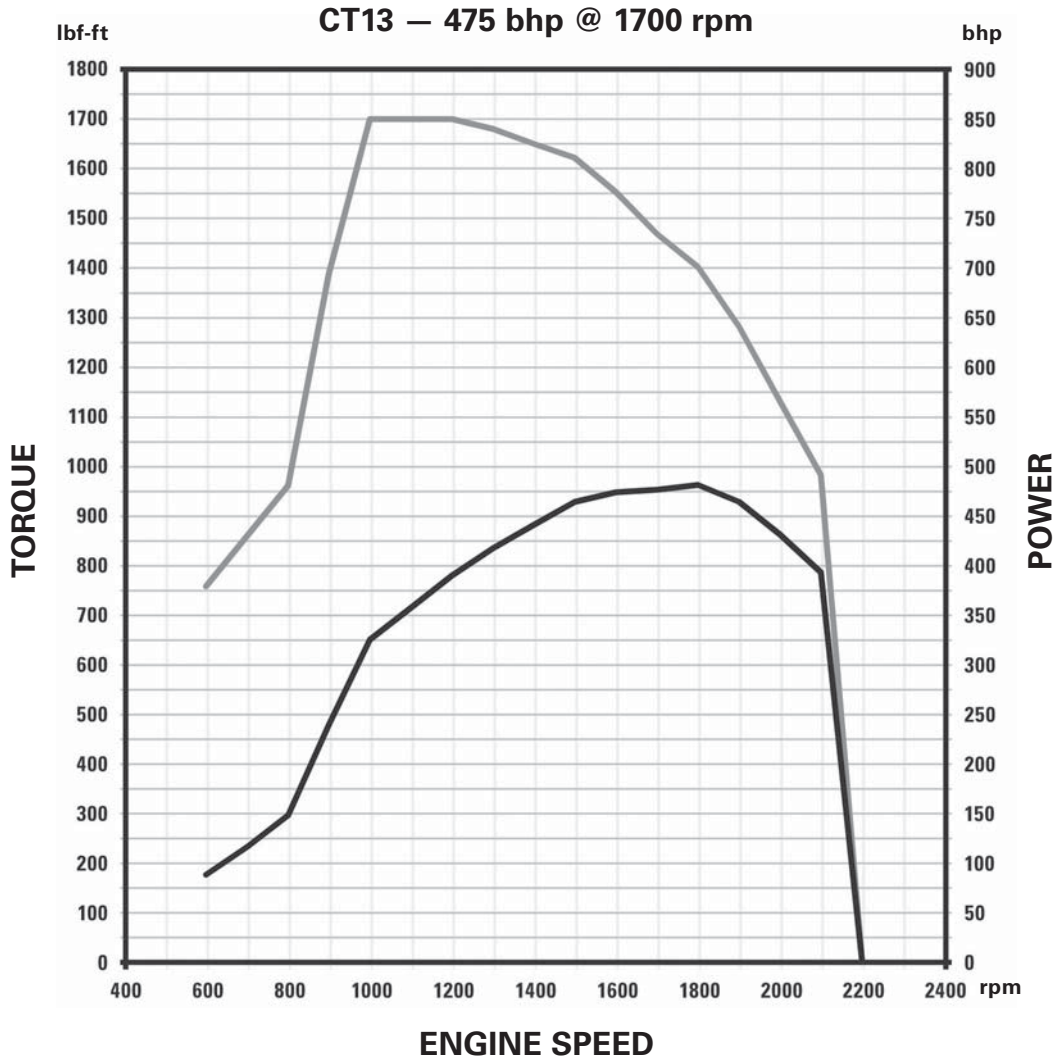

KEY  
— Torque  
— Power

Feature Code	Cat CX31 Automatic	CT681 6x4 114 BBC	CT680 6x4 124 BBC	CT660 6x4 116 BBC	CT660 6x4 122 BBC	CT660 4x4 122 BBC	CT660 6x6 122 BBC	CT680 8x6 124 BBC	CT660 8x6 116 BBC	CT660 8x6 122 BBC	Speeds	Rated lbf-ft	Gear Ratios									
													R4	R3	R2	R1	F1	F2	F3	F4	F5	F6
0013CZY	CX31 with Retarder for CT13 Engines	x	x	x	x			x	x	x	6	1900				3.97	*4.4	*2.2	1.53	1.00	0.72	0.61
0013CZZ	CX31 for CT13 Engines	x	x	x	x	x	x	x	x	x	6	1900				3.97	*4.4	*2.2	1.53	1.00	0.72	0.61

\*Multiply 1st and 2nd by 1.9 to account for torque converter.  
 Torque converter locks up at 75% of 2nd gear speed range.

Feature Code	Eaton Manual Air Shift	CT681 6x4 114 BBC	CT680 6x4 124 BBC	CT660 6x4 116 BBC	CT660 6x4 122 BBC	CT660 4x4 122 BBC	CT660 6x6 122 BBC	CT680 8x6 124 BBC	CT660 8x6 116 BBC	CT660 8x6 122 BBC	Speeds	Rated lbf-ft	Gear Ratios										
													R4	R3	R2	R1	F1	F2	F3	F4	F5	F6	F7
0013GHC	Fuller FRO-13210C	x		x						x	10	1350			2.80	13.75	12.69	9.29	6.75	4.90	3.62	2.64	1.90
0013GHJ	Fuller FR-14210B	x	x	x	x	x					10	1450			2.72	12.12	11.06	8.19	6.05	4.46	3.34	2.48	1.83
0013GHL	Fuller FRO-14210C	x	x	x	x	x				x	10	1450			2.80	13.75	12.69	9.29	6.75	4.90	3.62	2.64	1.90
0013GHW	Fuller RTO(F)-14908LL	x	x	x	x	x	x				10	1450		2.89	9.85	15.22	14.56	9.42	6.24	4.63	3.40	2.53	1.83
0013GGV	Fuller FRO-12210C	x		x							10	1550			2.80	13.75	12.69	9.29	6.75	4.90	3.62	2.64	1.90
0013GHP	Fuller FRO-15210C	x	x	x	x			x	x	x	10	1550			2.80	13.75	12.69	9.29	6.75	4.90	3.62	2.64	1.90
0013GHS	Fuller FRO-16210C	x	x	x	x	x	x	x	x	x	10	1650			2.80	13.75	12.69	9.29	6.75	4.90	3.62	2.64	1.90
0013GHX	Fuller RTO(F)-16908LL	x	x	x	x	x	x				10	1650		2.89	9.85	15.22	14.56	9.42	6.24	4.63	3.40	2.53	1.83
0013GMZ	Fuller RTO(F)-14909ALL	x	x	x	x	x	x				11	1450		3.43	13.03	20.84	26.08	16.30	11.85	7.41	5.23	3.79	2.77
0013GNA	Fuller RTO(F)-16909ALL	x	x	x	x	x	x	x	x	x	11	1650		3.43	13.03	20.84	26.08	16.30	11.85	7.41	5.23	3.79	2.77
0013GRD	Fuller RTLO(F)-12913A	x	x	x	x	x	x				13	1250			3.50	13.22	12.31	8.64	6.11	4.43	3.23	2.29	1.95
0013GRE	Fuller RTLO(F)-14913A					x	x				13	1450			3.50	13.22	12.31	8.64	6.11	4.43	3.23	2.29	1.95
0013GKJ	Fuller RTLO(F)-16913A	x	x	x	x						13	1650			3.50	13.22	12.31	8.64	6.11	4.43	3.23	2.29	1.95
0013GJS	Fuller RTLO-18913A	x	x	x	x						13	1850			3.50	13.22	12.31	8.64	6.11	4.43	3.23	2.29	1.95
0013GHY	Fuller RTO(F)-16915	x	x	x	x			x	x	x	15	1650		2.17	7.73	13.14	13.31	10.20	7.88	6.07	4.77	7.83	6.00
0013GKL	Fuller RTLO(F)-16918B	x	x	x	x			x	x	x	18	1650	3.43	4.03	12.85	15.06	14.40	12.29	8.56	7.30	6.05	5.16	4.38
0013GKM	Fuller RTLO(F)-18918B	x	x	x	x			x	x	x	18	1850	3.43	4.03	12.85	15.06	14.40	12.29	8.56	7.30	6.05	5.16	4.38
0013GNM	Fuller RTLOF-20918B	x	x	x	x	x	x	x	x	x	18	2050	3.43	4.03	12.85	15.06	14.40	12.29	8.56	7.30	6.05	5.16	4.38

Chart continued on next page.

Appendix D  
● Transmission Specifications

On-Highway Trucks

Feature Code	Eaton Manual Air Shift	CT681 6x4 114 BBC	CT680 6x4 124 BBC	CT660 6x4 116 BBC	CT660 6x4 122 BBC	CT660 4x4 122 BBC	CT660 6x6 122 BBC	CT680 8x6 124 BBC	CT660 8x6 116 BBC	CT660 8x6 122 BBC	Speeds	Rated lbf-ft	Gear Ratios										
													F8	F9	F10	F11	F12	F13	F14	F15	F16	F17	F18
0013GHC	Fuller FRO-13210C	x		x						x	10	1350	1.38	1.00	0.74								
0013GHJ	Fuller FR-14210B	x	x	x	x	x	x				10	1450	1.36	1.00	0.75								
0013GHL	Fuller FRO-14210C	x	x	x	x	x	x				10	1450	1.38	1.00	0.74								
0013GHW	Fuller RTO(F)-14908LL	x	x	x	x	x	x				10	1450	1.36	1.00	0.74								
0013GGV	Fuller FRO-12210C	x		x							10	1550	1.38	1.00	0.74								
0013GHP	Fuller FRO-15210C	x	x	x	x			x	x	x	10	1550	1.38	1.00	0.74								
0013GHS	Fuller FRO-16210C	x	x	x	x	x	x	x	x	x	10	1650	1.38	1.00	0.74								
0013GHX	Fuller RTO(F)-16908LL	x	x	x	x	x	x				10	1650	1.36	1.00	0.74								
0013GMZ	Fuller RTO(F)-14909ALL	x	x	x	x	x	x				11	1450	1.95	1.38	1.00	0.73							
0013GNA	Fuller RTO(F)-16909ALL	x	x	x	x	x	x	x	x	x	11	1650	1.95	1.38	1.00	0.73							
0013GRD	Fuller RTLO(F)-12913A	x	x	x	x	x	x				13	1250	1.62	1.38	1.17	1.00	0.86	0.73					
0013GRE	Fuller RTLO(F)-14913A					x	x				13	1450	1.62	1.38	1.17	1.00	0.86	0.73					
0013GKJ	Fuller RTLO(F)-16913A	x	x	x	x						13	1650	1.62	1.38	1.17	1.00	0.86	0.73					
0013GJS	Fuller RTLO-18913A	x	x	x	x						13	1850	1.62	1.38	1.17	1.00	0.86	0.73					
0013GHY	Fuller RTO(F)-16915	x	x	x	x			x	x	x	15	1650	4.63	3.57	2.81	2.19	1.68	1.30	1.00	0.79			
0013GKL	Fuller RTLO(F)-16918B	x	x	x	x			x	x	x	18	1650	3.74	3.20	2.73	2.29	1.95	1.62	1.38	1.17	1.00	0.86	0.73
0013GKM	Fuller RTLO(F)-18918B	x	x	x	x			x	x	x	18	1850	3.74	3.20	2.73	2.29	1.95	1.62	1.38	1.17	1.00	0.86	0.73
0013GNM	Fuller RTLOF-20918B	x	x	x	x	x	x	x	x	x	18	2050	3.74	3.20	2.73	2.29	1.95	1.62	1.38	1.17	1.00	0.86	0.73

● Transmission Specifications

Feature Code	Eaton UltraShift Plus Vocational Aluminum Clutch Housing, Hill Start Aid	CT681 6x4 114 BBC	CT680 6x4 124 BBC	CT660 6x4 116 BBC	CT660 6x4 122 BBC	CT660 4x4 122 BBC	CT660 6x6 122 BBC	CT680 8x6 124 BBC	CT660 8x6 116 BBC	CT660 8x6 122 BBC	Speeds	Rated lbf-ft	Gear Ratios										
													R4	R3	R2	R1	F1	F2	F3	F4	F5	F6	F7
0013GWM	FO-12E308LL-VCS	x	x						x	10	1250		2.89	9.85	15.22	14.56	9.42	6.24	4.63	3.40	2.53	1.83	
0013GWN	FO-14E308LL-VCS	x	x	x	x			x	x	x	10	1450		2.89	9.85	15.22	14.56	9.42	6.24	4.63	3.40	2.53	1.83
0013GWE	FO-14E310C-VAS	x	x	x	x			x	x	x	10	1450			2.78	13.63	12.80	9.25	6.76	4.90	3.58	2.61	1.89
0013GWH	FOM-14E310C-VAS	x	x	x	x			x	x	x	10	1450			2.78	13.63	12.80	9.25	6.76	4.90	3.58	2.61	1.89
0013GWJ	FOM-15E310C-VAS	x	x	x	x			x	x	x	10	1550			2.78	13.63	12.80	9.25	6.76	4.90	3.58	2.61	1.89
0013GWP	FO-16E308LL-VCS	x	x	x	x			x	x	x	10	1650		2.89	9.85	15.22	14.56	9.42	6.24	4.63	3.40	2.53	1.83
0013GWG	FO-16E310C-VAS	x	x	x	x			x	x	x	10	1650			2.78	13.63	12.80	9.25	6.76	4.90	3.58	2.61	1.89
0013GWL	FOM-16E310C-VAS	x	x	x	x			x	x	x	10	1650			2.78	13.63	12.80	9.25	6.76	4.90	3.58	2.61	1.89
0013GWR	FO-17E308LL-VCS	x	x	x	x			x	x	x	10	1750		2.89	9.85	15.22	14.56	9.42	6.24	4.63	3.40	2.53	1.83
0013GWW	FO-14E309ALL-VMS	x	x	x	x			x	x	x	11	1450		3.43	13.03	20.84	26.08	16.30	11.85	7.41	5.23	3.79	2.77
0013GWW	FO-16E309ALL-VMS	x	x	x	x			x	x	x	11	1650		3.43	13.03	20.84	26.08	16.30	11.85	7.41	5.23	3.79	2.77
0013GWX	FO-17E309ALL-VMS	x	x	x	x	x	x	x	x	x	11	1750		3.43	13.03	20.84	26.08	16.30	11.85	7.41	5.23	3.79	2.77
0013GWS	FO-16E313A-VHP	x	x	x	x			x	x	x	13	1650		4.03	12.85	15.06	12.29	8.51	6.05	4.38	3.20	2.28	1.94
0013GWT	FO-18E313A-VHP	x	x	x	x			x	x	x	13	1850		4.03	12.85	15.06	12.29	8.51	6.05	4.38	3.20	2.28	1.94
0013GUZ	FO-20E313A-VHP	x	x	x	x			x	x	x	13	2050		4.03	12.85	15.06	12.29	8.51	6.05	4.38	3.20	2.28	1.94
0013GXE	FO-14E318B-VXP	x	x	x	x			x	x	x	18	1450	3.43	4.03	12.85	15.06	14.40	12.29	8.51	7.26	6.05	5.16	4.38
0013GXG	FO-16E318B-VXP	x	x	x	x			x	x	x	18	1650	3.43	4.03	12.85	15.06	14.40	12.29	8.51	7.26	6.05	5.16	4.38
0013GXD	FO-18E318B-MXP			x							18	1850	3.43	4.03	12.85	15.06	14.40	12.29	8.51	7.26	6.05	5.16	4.38
0013GXH	FO-18E318B-VXP	x	x	x	x			x	x	x	18	1850	3.43	4.03	12.85	15.06	14.40	12.29	8.51	7.26	6.05	5.16	4.38

Chart continued on next page.

Appendix D  
● Transmission Specifications

On-Highway Trucks

Feature Code	Eaton UltraShift Plus Vocational Aluminum Clutch Housing, Hill Start Aid	CT681 6x4 114 BBC	CT680 6x4 124 BBC	CT660 6x4 116 BBC	CT660 6x4 122 BBC	CT660 4x4 122 BBC	CT660 6x6 122 BBC	CT680 8x6 124 BBC	CT660 8x6 116 BBC	CT660 8x6 122 BBC	Speeds	Rated lbf-ft	Gear Ratios										
													F8	F9	F10	F11	F12	F13	F14	F15	F16	F17	F18
0013GWM	FO-12E308LL-VCS	x		x						x	10	1250	1.36	1.00	0.74								
0013GWN	FO-14E308LL-VCS	x	x	x	x			x	x	x	10	1450	1.36	1.00	0.74								
0013GWE	FO-14E310C-VAS	x	x	x	x			x	x	x	10	1450	1.38	1.00	0.73								
0013GWH	FOM-14E310C-VAS	x	x	x	x			x	x	x	10	1450	1.38	1.00	0.73								
0013GWJ	FOM-15E310C-VAS	x	x	x	x			x	x	x	10	1550	1.38	1.00	0.73								
0013GWP	FO-16E308LL-VCS	x	x	x	x			x	x	x	10	1650	1.36	1.00	0.74								
0013GWG	FO-16E310C-VAS	x	x	x	x			x	x	x	10	1650	1.38	1.00	0.73								
0013GWL	FOM-16E310C-VAS	x	x	x	x			x	x	x	10	1650	1.38	1.00	0.73								
0013GWR	FO-17E308LL-VCS	x	x	x	x			x	x	x	10	1750	1.36	1.00	0.74								
0013GWW	FO-14E309ALL-VMS	x	x	x	x			x	x	x	11	1450	1.95	1.38	1.00	0.73							
0013GWW	FO-16E309ALL-VMS	x	x	x	x			x	x	x	11	1650	1.95	1.38	1.00	0.73							
0013GWX	FO-17E309ALL-VMS	x	x	x	x	x	x	x	x	x	11	1750	1.95	1.38	1.00	0.73							
0013GWS	FO-16E313A-VHP	x	x	x	x			x	x	x	13	1650	1.62	1.38	1.17	1.00	0.86	0.73					
0013GWT	FO-18E313A-VHP	x	x	x	x			x	x	x	13	1850	1.62	1.38	1.17	1.00	0.86	0.73					
0013GUZ	FO-20E313A-VHP	x	x	x	x			x	x	x	13	2050	1.62	1.38	1.17	1.00	0.86	0.73					
0013GXE	FO-14E318B-VXP	x	x	x	x			x	x	x	18	1450	3.74	3.20	2.73	2.28	1.94	1.62	1.38	1.17	1.00	0.86	0.73
0013GXG	FO-16E318B-VXP	x	x	x	x			x	x	x	18	1650	3.74	3.20	2.73	2.28	1.94	1.62	1.38	1.17	1.00	0.86	0.73
0013GXD	FO-18E318B-MXP			x							18	1850	3.74	3.20	2.73	2.28	1.94	1.62	1.38	1.17	1.00	0.86	0.73
0013GXH	FO-18E318B-VXP	x	x	x	x			x	x	x	18	1850	3.74	3.20	2.73	2.28	1.94	1.62	1.38	1.17	1.00	0.86	0.73

Feature Code	Auxiliary Transmission and Transfer Case	CT681 6x4 114 BBC	CT680 6x4 124 BBC	CT660 6x4 116 BBC	CT660 6x4 122 BBC	CT660 4x4 122 BBC	CT660 6x6 122 BBC	CT680 8x6 124 BBC	CT660 8x6 116 BBC	CT660 8x6 122 BBC	Speeds	Rated lbf-ft	Gear Ratios										
													R4	R3	R2	R1	F1	F2					
0013TJP	TC-270 Fabco Transfer Case					x	x				2	12,000									1.00	2.23	
0013TJG	TC-142 Fabco Transfer Case					x	x				2	14,000										1.00	2.23
0013TKJ	TC-142 Fabco Transfer Case						x				2	14,000										1.00	2.23
0013TLC	TC-180 Fabco Transfer Case					x	x				1	15,000										1.00	
0013607	AT-1202 Aux Transmission, Eaton 2-Speed with Air Shift Controls	x	x	x	x				x	x	x	2	17,500									1.00	2.04



Feature Code	Description	CT681 6x4 114 BBC	CT680 6x4 124 BBC	CT660 6x4 116 BBC	CT660 6x4 122 BBC	CT660 4x4 122 BBC	CT660 6x6 122 BBC	CT680 8x6 124 BBC	CT660 8x6 116 BBC	CT660 8x6 122 BBC	Meritor/Spicer	Load Rating (lb)	Locking Diff Rear/ Mid/Forward	Lube Pump	Wheel Ends
<b>Single Drive Axles</b>															
0014051	RS-23-160					x					M	23,000			200
0014ARB	RS-23-160					x					M	23,000	R		200
0014ARK	RS-23-161					x					M	23,000	R		R
0014AHE	S23-190 Hypoid					x					S	23,000			R
0014AHG	S23-190D Hypoid					x					S	23,000	R		R
0014ARZ	RS-26-185 Standard Track					x					M	26,000			R
0014ASA	RS-26-185 Standard Track					x					M	26,000	R		R
0014ATN	RS-26-185 Wide Track					x					M	26,000	R		R
0014ASB	RS-30-185 Standard Track					x					M	30,000			T
0014ASD	RS-30-185 Standard Track					x					M	30,000	R		T
0014ERB	RS-30-380 Double Reduction					x					M	30,000			T
<b>Tandem Drive Axles</b>															
0014GGC	DD405/RD405	x	x	x	x						S	40,000	RF		200
0014GGD	DD405P/RD405	x	x	x	x						S	40,000	RF	Y	200
0014GJD	DST41/RST41	x	x	x	x						S	40,000			200
0014GJE	DST41P/RST41 0.44" Wall Housing	x	x	x	x						S	40,000		Y	200
0014GVJ	MT-40-A144 Vocational	x	x	x	x		x				M	40,000	R	Y	R
0014GVK	MT-40-A145 Vocational	x	x	x	x		x				M	40,000	R	Y	R
0014GVL	MT-40-A144	x	x								M	40,000	RF	Y	R
0014GVM	MT-40-A145 Vocational	x	x	x	x						M	40,000	RF	Y	R
0014GVN	MT-40-A144 Vocational	x	x	x	x		x				M	40,000	RF		R
0014GVR	MT-40-A144 Vocational	x	x	x	x		x				M	40,000	R		R
0014GVU	MT-40-14X-4DFR-P 0.433" Wall Housing Thickness	x	x	x	x		x				M	40,000		Y	R
0014GVY	MT-40-A144 Vocational	x	x	x	x		x				M	40,000			R
0014GVZ	MT-40-A145 Vocational	x	x	x	x		x				M	40,000			R
0014HRU	RT-44-145 Heavy Wall Housing	x	x	x	x		x				M	44,000	RF		200
0014GGU	DT463P/RT463 Two-Speed 18" Ring Gear	x	x	x	x						S	46,000			200
0014GJH	D46-170HP/R46-170H	x	x	x	x		x				S	46,000		Y	R
0014GJJ	D46-170HP/R46-170DH	x	x	x	x		x				S	46,000	R	Y	R
0014GJK	D46-170DHP/R46-170DH	x	x	x	x		x				S	46,000	RF	Y	R
0014GJN	D46-170DP/R46-170D	x	x	x	x						S	46,000	RF	Y	R
0014GRD	RT-46-160	x	x	x	x		x				M	46,000			200
0014GRP	RT-46-160	x	x	x	x		x				M	46,000	R		200
0014GRR	RT-46-160P	x	x	x	x						M	46,000		Y	200
0014GRS	RT-46-160P	x	x	x	x		x				M	46,000	R	Y	200
0014HRA	RT-46-164EH Wide Track	x	x	x	x		x				M	46,000	RF		200
0014HRC	RT-46-164EH Standard Width	x	x	x	x		x				M	46,000	RF		200
0014HRE	RT-46-164P Standard Width	x	x	x	x		x				M	46,000	RF	Y	200
0014HRH	RT-46-164P Wide Track	x	x	x	x		x				M	46,000	RF	Y	200
0014HRL	RT-46-160P	x	x	x	x		x				M	46,000	RF	Y	200
0014HRM	RT-46-160	x	x	x	x		x				M	46,000	RF		200
0014HRW	RT-46-164P	x	x	x	x						S	46,000		Y	R
0014GTS	RT-52-185	x	x	x	x		x				M	52,000		Y	R
0014GTW	RT-52-185P	x	x	x	x						M	52,000	R	Y	R
0014GUV	RT-52-185P	x	x	x	x						M	52,000	R	Y	T
0014GRJ	RT-58-380 Double Reduction Standard Track 74"	x	x	x	x						M	58,000			T
0014GTT	RT-58-185	x	x	x	x						M	58,000		Y	T
0014GTU	RT-58-185	x	x	x	x		x				M	58,000	R	Y	T
0014GRM	RT-70-380 Double Reduction Standard Track 73.75"	x	x	x	x		x				M	70,000			W
<b>Tridem Drive Axles</b>															
0014HRG	RZ-166 EH Wide Track							x	x	x	M	53,000	RMF		200

Axles are Single Reduction unless otherwise noted.

Feature Code

**Axle Ratios**

Single Drive Axles																										
0014051					3.07	3.21	3.42	3.58	3.73	3.91	4.10	4.30	4.56	4.89	5.38	5.63	6.14	6.43	6.83	7.17						
0014ARB					3.07	3.21	3.42	3.58	3.73	3.91	4.10	4.30	4.56	4.89	5.38	5.63	6.14	6.43	6.83	7.17						
0014ARK	2.50	2.67	2.80	2.93	3.08	3.21	3.42	3.58	3.73	3.91	4.10	4.30	4.56	4.89	5.38	5.63	6.14	6.43	6.83	7.17						
0014AHE		2.69	2.87	2.93	3.07	3.21	3.42	3.58	3.73	3.91	4.10	4.30		4.78	5.25	5.38	5.63	6.14	6.83	7.17				7.83		
0014AHG		2.69	2.87	2.93	3.07	3.21	3.42	3.58	3.73	3.91	4.10	4.30		4.78	5.25	5.38	5.63	6.14	6.83	7.17				7.83		
0014ARZ				2.93	3.08	3.21	3.42	3.58	3.73	3.91	4.10	4.30	4.56	4.89	5.13	5.38	5.63	5.86	6.14	6.83	7.17			7.40		
0014ASA				2.93	3.08	3.21	3.42	3.58	3.73	3.91	4.10	4.30	4.56	4.89	5.13	5.38	5.63	5.86	6.14	6.83	7.17			7.40		
0014ATN				2.93	3.08	3.21	3.42	3.58	3.73	3.91	4.10	4.30	4.56	4.89	5.13	5.38	5.63	5.86	6.14	6.83	7.17			7.40		
0014ASB				2.93	3.08	3.21	3.42	3.58	3.73	3.91	4.10	4.30	4.56	4.89	5.13	5.38	5.63	5.86	6.14	6.83	7.17			7.40		
0014ASD				2.93	3.08	3.21	3.42	3.58	3.73	3.91	4.10	4.30	4.56	4.89	5.13	5.38	5.63	5.86	6.14	6.83	7.17			7.40		
0014ERB				2.93	3.08	3.21	3.42	3.58	3.73	3.91	4.10	4.30	4.56	4.89	5.13	5.38	5.63	5.86	6.14	6.83	7.17			7.40		
Tandem Drive Axles																										
0014GGC		2.64	2.85	2.93	3.08	3.25	3.36	3.36	3.55	3.70	3.90	4.11	4.33	4.63	4.88	5.29	5.57	6.17	6.50	7.17						
0014GGD		2.64	2.85	2.93	3.08	3.25	3.36	3.36	3.55	3.70	3.90	4.11	4.33	4.63	4.88	5.29	5.57	6.17	6.50	7.17						
0014GJD		2.64			3.08	3.25	3.36		3.55	3.70	3.90	4.11	4.33													
0014GJE		2.64			3.08	3.25	3.36		3.55	3.70	3.90	4.11	4.33													
0014GVJ	2.47	2.64			3.08	3.25	3.36	3.55	3.70	3.90	4.11	4.33	4.63	4.88	5.29	5.86	6.14	6.43	6.83	7.17						
0014GVK	2.47	2.64			3.08	3.25	3.36	3.55	3.70	3.90	4.11	4.33	4.63	4.88	5.29	5.86	6.14	6.43	6.83	7.17						
0014GVL	2.47	2.64			3.08	3.25	3.36	3.55	3.70	3.90	4.11	4.33	4.63	4.88	5.29	5.86	6.14	6.43	6.83	7.17						
0014GVM	2.47	2.64			3.08	3.25	3.36	3.55	3.70	3.90	4.11	4.33	4.63	4.88	5.29	5.86	6.14	6.43	6.83	7.17						
0014GVN	2.47	2.64			3.08	3.25	3.36	3.55	3.70	3.90	4.11	4.33	4.63	4.88	5.29	5.86	6.14	6.43	6.83	7.17						
0014GVR	2.47	2.64			3.08	3.25	3.36	3.55	3.70	3.90	4.11	4.33	4.63	4.88	5.29	5.86	6.14	6.43	6.83	7.17						
0014GVU	2.47	2.64			3.08	3.25	3.36	3.55	3.70	3.90	4.11															
0014GVY	2.47	2.64			3.08	3.25	3.36	3.55	3.70	3.90	4.11	4.33	4.63	4.88	5.29	5.86	6.14	6.43	6.83	7.17						
0014GVZ	2.47	2.64			3.08	3.25	3.36	3.55	3.70	3.90	4.11	4.33	4.63	4.88	5.29	5.86	6.14	6.43	6.83	7.17						
0014HRU						3.42	3.58	3.73	3.91	4.10	4.30	4.56	4.89	5.38	5.63	6.14	6.43	6.83	7.17							
0014GGU		3.7/5.04		4.56/6.20	3.90/5.31	4.88/6.64			4.11/5.60	5.43/7.39	4.33/5.91	6.17/8.40														
0014GJH					3.07	3.21	3.42		3.58	3.73	3.91	4.10	4.30	4.56	4.78	5.25	5.38	5.57	6.14	6.83	7.17					
0014GJJ					3.07	3.21	3.42		3.58	3.73	3.91	4.10	4.30	4.56	4.78	5.25	5.38	5.57	6.14	6.83	7.17					
0014GJK					3.07	3.21	3.42		3.58	3.73	3.91	4.10	4.30	4.56	4.78	5.25	5.38	5.57	6.14	6.83	7.17					
0014GJN					3.07	3.21	3.42		3.58	3.73	3.91	4.10	4.30	4.56	4.78	5.25	5.38	5.57	6.14	6.83	7.17					
0014GRD						3.42	3.58	3.73	3.91	4.10	4.30	4.56	4.89	5.38	5.63	6.14	6.43	6.83	7.17							
0014GRP						3.42	3.58	3.73	3.91	4.10	4.30	4.56	4.89	5.38	5.63	6.14	6.43	6.83	7.17							
0014GRR						3.42	3.58	3.73	3.91	4.10	4.30	4.56	4.89	5.38	5.63	6.14	6.43	6.83	7.17							
0014GRS						3.42	3.58	3.73	3.91	4.10	4.30	4.56	4.89	5.38	5.63	6.14	6.43	6.83	7.17							
0014HRA						3.42	3.58	3.73	3.91	4.10	4.30	4.56	4.89	5.38	5.63	6.14	6.43	6.83	7.17							
0014HRC						3.42	3.58	3.73	3.91	4.10	4.30	4.56	4.89	5.38	5.63	6.14	6.43	6.83	7.17							
0014HRE						3.42	3.58	3.73	3.91	4.10	4.30	4.56	4.89	5.38	5.63	6.14	6.43	6.83	7.17							
0014HRH						3.42	3.58	3.73	3.91	4.10	4.30	4.56	4.89	5.38	5.63	6.14	6.43	6.83	7.17							
0014HRL						3.42	3.58	3.73	3.91	4.10	4.30	4.56	4.89	5.38	5.63	6.14	6.43	6.83	7.17							
0014HRM						3.42	3.58	3.73	3.91	4.10	4.30	4.56	4.89	5.38	5.63	6.14	6.43	6.83	7.17							
0014HRW						3.42		3.58	3.73	3.91	4.10	4.30	4.56	4.89	5.38	5.63	6.14	6.43	6.83	7.17						
0014GTS									3.73		4.10	4.30		4.89	5.38	6.14	6.83	7.17								
0014GTW									3.73		4.10	4.30		4.89	5.38	6.14	6.83	7.17								
0014GUV									3.73		4.10	4.30		4.89	5.38	6.14	6.83	7.17								
0014GRJ																5.52	6.07	6.37	6.75	7.24	7.83	9.14	10.12	10.62		
0014GTT									3.73		4.10	4.30		4.89	5.38	6.14	6.83	7.17								
0014GTU									3.73		4.10	4.30		4.89	5.38	6.14	6.83	7.17								
0014GRM																5.52	6.07	6.37	6.75	7.24	7.83	9.14	10.12	10.62		
Tridem Drive Axles																										
0014HRG					3.42	3.58	3.73	3.91	4.10	4.30	4.56	4.89	5.38	5.63	6.14	6.43	6.83	7.17								

Axles are Single Reduction unless otherwise noted.

- Front Axle Specifications
- Lift Axle Specifications

Feature Code	Description											Single Reduction	Load Rating (lb)	Axle Ratios													
		CT681 6x4 114 BBC	CT680 6x4 124 BBC	CT660 6x4 116 BBC	CT660 6x4 122 BBC	CT660 4x4 122 BBC	CT660 6x6 122 BBC	CT680 8x6 124 BBC	CT660 8x6 116 BBC	CT660 8x6 122 BBC																	
<b>Front Drive Axles</b>																											
0002EYU	Fabco SDA-1800 Hub Piloted					x	x					Y	18,000			3.90	4.11	4.33	4.56	4.88	5.29			5.57	6.14	6.57	7.17
0002EYV	Fabco SDA-2100 Hub Piloted					x	x					Y	21,000			3.90	4.11	4.33	4.56	4.88	5.29			5.57	6.14	6.57	7.17
0002EYN	Fabco SDA-2300					x	x					Y	23,000	3.55	3.70	3.90	4.11	4.33	4.56	4.88	5.29	5.43			6.17	6.50	6.67

Feature Code	Description											I-Beam	Load Rating (lb)	Wide Track	Meritor/Spicer	
		CT681 6x4 114 BBC	CT680 6x4 124 BBC	CT660 6x4 116 BBC	CT660 6x4 122 BBC	CT660 4x4 122 BBC	CT660 6x6 122 BBC	CT680 8x6 124 BBC	CT660 8x6 116 BBC	CT660 8x6 122 BBC						
<b>Front Non Drive Axles</b>																
0002ARA	FF-961	x										Y	12,000			M
0002ARW	MFS-12-143A		x	x	x							Y	12,000	Y	M	
0002227	FF-942	x										y	13,200		M	
0002ASG	MFS-13-143A		x	x	x							Y	13,200	Y	M	
0002ARG	FG-941	x										Y	14,600		M	
0002ASM	MFS-14-143A		x	x	x							Y	14,600	Y	M	
0002231	FL-941	x										y	16,000		M	
0002AEU	I-160W			x	x					x	x	Y	16,000	Y	S	
0002ARU	MFS-16-143A		x	x	x			x	x	x	Y	16,000	Y	M		
0002AUR	MFS-16-133A		x	x	x			x	x	x	Y	16,000	Y	M		
0002AYL	D-2000W			x	x					x	x	Y	16,000	Y	S	
0002232	FL-941	x										y	18,000		M	
0002AEV	I-180W			x	x					x	x	Y	18,000	Y	S	
0002ARZ	MFS-18-133A		x	x	x			x	x	x	Y	18,000	Y	M		
0002AYK	D-2000W			x	x					x	x	Y	18,000	Y	S	
0002233	FL-941	x										y	20,000		M	
0002AEW	I-200W			x	x					x	x	Y	20,000	Y	S	
0002ARY	MFS-20-133A		x	x	x			x	x	x	Y	20,000	Y	M		
0002AYJ	D-2000W			x	x					x	x	Y	20,000	Y	S	
0002AGT	I-220W			x	x					x	x	Y	22,000	Y	S	
0002ATB	MFS-20-133A			x	x					x	x	Y	22,000	Y	M	

Feature Code	Description	CT660 6x4 116 BBC	CT660 6x4 122 BBC	CT680 6x4 124 BBC	CT681 6x4 114 BBC	Capacity (lb)	Pusher/Tag
<b>Lift Axles</b>							
0014WML	Watson and Chalin SL-0893 Tru Track includes Three Self-Steer Axles			x	x	8000	P
0014WMA	Watson and Chalin SL1190 Tru Track Alumilite includes One Self-Steer Axle	x	x	x	x	13,200	P
0014WMB	Watson and Chalin SL1190 Tru Track Alumilite includes Two Self-Steer Axles	x	x	x	x	13,200	P
0014WLM	Watson and Chalin AL-2200 includes One Non-Steer Axle	x	x	x	x	20,000	P
0014WMM	Watson and Chalin SL-2050 Tru Track includes One Self-Steer Axle	x	x	x	x	20,000	P
0014WMC	Watson and Chalin SL1190 Tru Track Alumilite includes One Self-Steer Axle	x	x	x	x	13,200	T
0014WLR	Watson and Chalin AL-2200 includes One Non-Steer Axle	x	x	x	x	20,000	T

**CX31 Startability Reference Guide (for Common GVWR/GCCR and Axle Ratios)**

Maximum Startability (% Grade) at given weight for the most common Axle Ratios: 4.56, 4.89, and 5.38

Tire Revs/Mile = 488

Engine	HP/Torque	60,000 lb GVWR/GCCR			70,000 lb GVWR/GCCR			80,000 lb GVWR/GCCR			90,000 lb GVWR/GCCW		
		4.56	4.89	5.38	4.56	4.89	5.38	4.56	4.89	5.38	4.56	4.89	5.38
CT13	365/1250	22.9	24.8	27.5	19.5	21.0	23.3	16.9	18.2	20.2	14.9	16.1	17.7
CT13	370/1350	23.4	25.2	28.0	19.8	21.3	23.6	17.2	18.5	20.5	15.1	16.3	18.0
CT13	390/1450	24.0	25.9	28.8	20.3	21.9	24.3	17.6	19.0	21.0	15.6	16.8	18.5
CT13	410/1450	29.5	31.9	35.5	24.9	26.9	29.9	21.6	23.2	25.8	19.0	20.5	22.6
CT13	430/1550	30.7	33.2	37.0	25.9	27.9	31.1	22.4	24.2	26.8	19.7	21.3	23.5
CT13	475/1700	33.3	36.0	40.3	28.0	30.3	33.7	24.2	26.1	29.0	21.3	23.0	25.4

If your Truck is outside the weight or axle ratios specified above, please contact the Truck Coordinator at your Cat dealer for assistance. Other options are available.

Feature	Size	Description	Manufacturer	Rev/Mile	Load Range	Ply	Maximum Load Single (lb)	Unloaded Diameter (in)	Application
7372130524	11R22.5	S581	GENERAL	500	G	14	6175	41.4	Long haul, over-the-highway steering and all-position use
7372135414	11R22.5	HSL2	CONTINENTAL	500	G	14	6175	41.4	Long haul, over-the-highway steering and all-purpose use
7372135415	11R22.5	HSR2	CONTINENTAL	498	G	14	6175	41.6	Regional hauling and on/off road, all-position
7372138107	11R22.5	G661 HAS	GOODYEAR	497	G	14	6175	41.8	Enhanced toughness for high-scrub applications
7372138108	11R22.5	G662 FUEL MAX	GOODYEAR	497	G	14	6175	41.8	Long tread life and toughness for regional highway and local driving
7372138116	11R22.5	G399 LHS FUEL MAX	GOODYEAR	504	G	14	6175	41.2	Long haul/regional steer fuel efficiency combined with long mileage
7472133208	11R22.5	XZY-3	MICHELIN	496	G	14	6175	41.8	All-position radial designed for exceptional wear and traction in mixed on/off road service
7472133269	11R22.5	XZE2	MICHELIN	501	G	14	6175	41.3	Regional, all-position radial with extra-wide, extra-deep tread designed to help deliver best wear in high scrub applications
7382130125	11R22.5	G287 MSA	GOODYEAR	498	H	16	6610	41.7	Superior over-the-road performance
7382130126	11R22.5	G288 MSA	GOODYEAR	498	H	16	6610	41.9	Outstanding performance in off-highway rough road conditions
7382135413	11R22.5	HDO	CONTINENTAL	490	H	16	6610	42.4	Logging, mining, construction and other aggressive, off-road traction needs
7382135419	11R22.5	HSC1	CONTINENTAL	496	H	16	6610	41.7	Coal haulers, logging, construction, waste haulers, and other all-position service
7382135420	11R22.5	HDC1	CONTINENTAL	488	H	16	6610	42.4	Coal haulers, logging, construction, waste haulers, school buses and other on/off highway service
7382138103	11R22.5	G287 MSA DURASEAL	GOODYEAR	498	H	16	6610	41.7	Puncture-sealing* superior over-the-road performance
7482133208	11R22.5	XZY-3	MICHELIN	496	H	16	6610	41.8	All-position radial designed for exceptional wear and traction in mixed on/off road service
7482133269	11R22.5	XZE2	MICHELIN	501	H	16	6610	41.4	Regional, all-position radial with extra-wide, extra-deep tread designed to help deliver best wear in high scrub applications
7374228116	11R24.5	G399 LHS FUEL MAX	GOODYEAR	481	G	14	6610	43.2	Long haul/regional steer fuel efficiency combined with long mileage
7474223268	11R24.5	XZA3+	MICHELIN	479	G	14	6610	43.3	Ultra-fuel-efficient radial that delivers long original tread life in long haul steer service
7474223269	11R24.5	XZE2	MICHELIN	476	G	14	6610	43.5	Regional, all-position radial with extra-wide, extra-deep tread designed to help deliver best wear in high scrub applications
7384220125	11R24.5	G287 MSA	GOODYEAR	475	H	16	7160	43.7	Superior over-the-road performance
7384220162	11R24.5	UNISTEEL G177	GOODYEAR	471	H	16	7160	44.3	Seals tread punctures* and is for rugged off-road conditions like coal fields
7384225415	11R24.5	HSR2	CONTINENTAL	476	H	16	7160	43.5	Regional hauling and on/off road, all-position

All tires listed are radials.

Availability can change without warning.

\*Seals up to ¼" diameter punctures in the repairable area of the tread. Does not seal sidewall punctures.

## Appendix H ● Front Tire Specifications

## On-Highway Trucks

Feature	Size	Description	Manufacturer	Rev/Mile	Load Range	Ply	Maximum Load Single (lb)	Unloaded Diameter (in)	Application
7384228108	11R24.5	G662 FUEL MAX	GOODYEAR	497	H	16	6610	41.8	Long tread life and toughness for regional highway and local driving
6354060162	1200R24	UNISTEEL G177	GOODYEAR	423	J	18	9370	49.4	Seals tread punctures* and is for rugged off-road conditions like coal fields
7382150125	12R22.5	G287 MSA	GOODYEAR	482	H	16	7390	43.1	Superior over-the-road performance
7382150162	12R22.5	UNISTEEL G177	GOODYEAR	478	H	16	7390	43.7	Seals tread punctures* and is for rugged off-road conditions like coal fields
7382155419	12R22.5	HSC1	CONTINENTAL	482	H	16	7390	43.0	Coal haulers, logging, construction, waste haulers, and other all-position service
7382158103	12R22.5	G287 MSA DURASEAL	GOODYEAR	482	H	16	7390	43.1	Puncture-sealing* superior over-the-road performance
7382158107	12R22.5	G661 HAS	GOODYEAR	484	H	16	7390	42.9	Enhanced toughness for high-scrub applications
7422153253	12R22.5	XZE	MICHELIN	486	H	16	7390	42.6	All-position radial with extra-wide, extra-deep tread designed to help deliver best wear in high scrub applications
7482153208	12R22.5	XZY-3	MICHELIN	483	H	16	7390	42.9	All-position radial designed for exceptional wear and traction in mixed on/off road service
7384240125	12R24.5	G287 MSA	GOODYEAR	463	H	16	7830	44.9	Superior over-the-road performance
7384240162	12R24.5	UNISTEEL G177	GOODYEAR	457	H	16	7830	45.7	Seals tread punctures* and is for rugged off-road conditions like coal fields
7484243208	12R24.5	XZY-3	MICHELIN	461	H	16	7830	44.9	All-position radial designed for exceptional wear and traction in mixed on/off road service
7652543208	315/80R22.5	XZY-3	MICHELIN	486	L	20	9090	42.9	All-position radial designed for exceptional wear and traction in mixed on/off road service
7682543212	315/80R22.5	XZU-S2	MICHELIN	488	L	20	10,000	42.8	All-position tire with high carrying capacity designed for exceptional tread life in high scrub urban applications such as refuse vehicles
7782548109	315/80R22.5	G289 WHA	GOODYEAR	484	L	20	10,200	43.1	Offers a 68 MPH speed rating and helps provide outstanding performance in waste haul applications
7792545416	315/80R22.5	HSU2+	CONTINENTAL	481	L	20	10,000	43.0	Waste haulers, construction and other on/off highway service
7602653208	385/65R22.5	XZY-3	MICHELIN	491	J	18	9370	42.4	All-position radial designed for exceptional wear and traction in mixed on/off road service
7652663208	425/65R22.5	XZY-3	MICHELIN	465	L	20	11,400	44.7	All-position radial designed for exceptional wear and traction in mixed on/off road service
7652663267	425/65R22.5	XZL	MICHELIN	467	L	20	11,400	44.8	All-terrain, all-position radial for special service such as Emergency Response vehicles
7752665412	425/65R22.5	HTC1	CONTINENTAL	465	L	20	11,400	44.5	Super single fitment for steer and trailer positions
7602673208	445/65R22.5	XZY-3	MICHELIN	455	L	20	12,800	45.8	All-position radial designed for exceptional wear and traction in mixed on/off road service

All tires listed are radials.

Availability can change without warning.

\*Seals up to ¼" diameter punctures in the repairable area of the tread. Does not seal sidewall punctures.

Feature	Size	Description	Manufacturer	Rev/Mile	Load Range	Ply	Maximum Load Single (lb)	Maximum Load Dual (lb)	Unloaded Diameter (in)	Application
7372130509	11R22.5	D660	GENERAL	492	G	14	6175	5840	42.1	Tandem drive axle to long and short over-the-highway use
7372130524	11R22.5	S581	GENERAL	500	G	14	6175	5840	41.4	Long haul, over-the-highway steering and all-position use
7372135401	11R22.5	HDL ECO PLUS	CONTINENTAL	493	G	14	6175	5840	42.0	Long haul, over the highway, drive position
7372135414	11R22.5	HSL2	CONTINENTAL	500	G	14	6175	5840	41.4	Long haul, over-the-highway steering and all-purpose use
7372135415	11R22.5	HSR2	CONTINENTAL	498	G	14	6175	5840	41.6	Regional hauling and on/off road, all-position
7372135418	11R22.5	HDR1	CONTINENTAL	495	G	14	6175	5840	41.8	Drive position, short and long-haul — on/off highway service (depending on conditions)
7372138101	11R22.5	G305AT LHD FUEL MAX	GOODYEAR	495	G	14	6175	5840	42.2	Long haul/regional — a fuel-efficient tire that provides long mileage
7372138107	11R22.5	G661 HSA1	GOODYEAR	497	G	14	6175	5840	41.8	Enhanced toughness for high-scrub applications
7372138108	11R22.5	G662 FUEL MAX	GOODYEAR	497	G	14	6175	5840	41.8	Long tread life and toughness for regional highway and local driving
7372138116	11R22.5	G399 LHS FUEL MAX	GOODYEAR	504	G	14	6175	5840	41.2	Long haul/regional steer fuel efficiency combined with long mileage
7372138118	11R22.5	G572 LHD FUEL MAX	GOODYEAR	492	G	14	6175	5840	42.4	A fuel-efficient long haul drive tire with long mileage
7402133217	11R22.5	XDE M/S	MICHELIN	498	G	14	6175	5840	41.6	The open shoulder drive axle engineered for excellent mileage and traction across a wide range of applications
7472133208	11R22.5	XZY-3	MICHELIN	496	G	14	6175	5840	41.8	All-position radial designed for exceptional wear and traction in mixed on/off road service
7472133264	11R22.5	XDN2	MICHELIN	496	G	14	6175	5840	41.7	All-weather, non-directional, premium drive tire optimized for exceptional traction with no compromise on tread wear
7472133269	11R22.5	XZE2	MICHELIN	501	G	14	6175	5840	41.3	Regional, all-position radial with extra-wide, extra-deep tread designed to help deliver best wear in high scrub applications
7472133274	11R22.5	XDA5	MICHELIN	497	G	14	6175	5840	41.7	Long wearing long haul drive tire featuring regenerating tread features that deliver excellent traction late in life
7382130121	11R22.5	G182 RSD	GOODYEAR	496	H	16	6610	6005	42.1	All-around tire for regional service
7382130125	11R22.5	G287 MSA	GOODYEAR	498	H	16	6610	6005	41.7	Superior over-the-road performance
7382130126	11R22.5	G288 MSA	GOODYEAR	498	H	16	6610	6005	41.9	Outstanding performance in off-highway rough road conditions
7382130162	11R22.5	UNISTEEL G177	GOODYEAR	493	H	16	6610	6005	42.3	Seals tread punctures* and is for rugged off-road conditions like coal fields
7382135401	11R22.5	HDL ECO PLUS	CONTINENTAL	493	H	16	6610	6005	42.0	Long haul, over the highway, drive position

All tires listed are radials.

Availability can change without warning.

\*Seals up to ¼" diameter punctures in the repairable area of the tread. Does not seal sidewall punctures.

# Appendix I

## ● Rear Tire Specifications

# On-Highway Trucks

Feature	Size	Description	Manufacturer	Rev/Mile	Load Range	Ply	Maximum Load Single (lb)	Maximum Load Dual (lb)	Unloaded Diameter (in)	Application
7382135413	11R22.5	HDO	CONTINENTAL	490	H	16	6610	6005	42.4	Logging, mining, construction and other aggressive, off-road traction needs
7382135417	11R22.5	HDL2 DL	CONTINENTAL	491	H	16	6610	6005	42.4	Long haul, over the highway, drive position
7382135418	11R22.5	HDR1	CONTINENTAL	495	H	16	6610	6005	41.8	Drive position, short and long-haul — on/off highway service (depending on conditions)
7382135419	11R22.5	HSC1	CONTINENTAL	496	H	16	6610	6005	41.7	Coal haulers, logging, construction, waste haulers and other all-position service
7382135420	11R22.5	HDC1	CONTINENTAL	488	H	16	6610	6005	42.4	Coal haulers, logging, construction, waste haulers, school buses and other on/off highway service
7382138103	11R22.5	G287 MSA DURASEAL	GOODYEAR	498	H	16	6610	6005	41.7	Puncture-sealing* superior over-the-road performance
7452133217	11R22.5	XDE M/S	MICHELIN	497	H	16	6610	5950	41.7	The open shoulder drive axle engineered for excellent mileage and traction across a wide range of applications
7452133276	11R22.5	XDS2	MICHELIN	494	H	16	6610	6005	41.9	Drive axle radial for year round traction, optimized for winter conditions and limited all position service
7482133208	11R22.5	XZY-3	MICHELIN	496	H	16	6610	6005	41.8	All-position radial designed for exceptional wear and traction in mixed on/off road service
7482133213	11R22.5	XDE2+	MICHELIN	497	H	16	6940	6395	41.7	Open shoulder drive axle radial designed for regional/highway service (directional tread)
7482133264	11R22.5	XDN2	MICHELIN	496	H	16	6610	6005	41.6	All-weather, non-directional, premium drive tire optimized for exceptional traction with no compromise on tread wear
7482133269	11R22.5	XZE2	MICHELIN	501	H	16	6610	6005	41.4	Regional, all-position radial with extra-wide, extra-deep tread designed to help deliver best wear in high scrub applications
7374228116	11R24.5	G399 LHS FUEL MAX	GOODYEAR	481	G	14	6610	6005	43.2	Long haul/regional steer fuel efficiency combined with long mileage
7474223217	11R24.5	XDE M/S	MICHELIN	475	G	14	6610	6005	43.8	The open shoulder drive axle engineered for excellent mileage and traction across a wide range of applications
7474223262	11R24.5	XDA3	MICHELIN	473	G	14	6610	6005	43.8	Fuel-efficient, standard drive tire that helps deliver long, even tread wear and a smooth quiet ride
7474223268	11R24.5	XZA3+	MICHELIN	479	G	14	6610	6005	43.3	Ultra-fuel-efficient radial that delivers long original tread life in long haul steer service
7474223269	11R24.5	XZE2	MICHELIN	476	G	14	6610	6005	43.5	Regional, all-position radial with extra-wide, extra-deep tread designed to help deliver best wear in high scrub applications
7474223274	11R24.5	XDA5	MICHELIN	472	G	14	6610	6005	43.8	Long wearing long haul drive tire featuring regenerating tread features that deliver excellent traction late in life

All tires listed are radials.

Availability can change without warning.

\*Seals up to ¼" diameter punctures in the repairable area of the tread. Does not seal sidewall punctures.



Feature	Size	Description	Manufacturer	Rev/Mile	Load Range	Ply	Maximum Load Single (lb)	Maximum Load Dual (lb)	Unloaded Diameter (in)	Application
7384220121	11R24.5	G182 RSD	GOODYEAR	473	H	16	7160	6610	44.1	All-around tire for regional service
7384220125	11R24.5	G287 MSA	GOODYEAR	475	H	16	7160	6610	43.7	Superior over-the-road performance
7384220162	11R24.5	UNISTEEL G177	GOODYEAR	471	H	16	7160	6610	44.3	Seals tread punctures* and is for rugged off-road conditions like coal fields
7384225415	11R24.5	HSR2	CONTINENTAL	476	H	16	7160	6610	43.5	Regional hauling and on/off road, all-position
7384228105	11R24.5	G282 MSD	GOODYEAR	475	H	16	7160	6610	43.9	Long on-/off-highway performance
7384228108	11R24.5	G662 FUEL MAX	GOODYEAR	497	H	16	6610	6005	41.8	Long tread life and toughness for regional highway and local driving
7484223217	11R24.5	XDE M/S	MICHELIN	474	H	16	7160	6610	43.9	The open shoulder drive axle engineered for excellent mileage and traction across a wide range of applications
7484223274	11R24.5	XDA5	MICHELIN	471	H	16	7160	6610	43.8	Long wearing long haul drive tire featuring regenerating tread features that deliver excellent traction late in life
6354060162	1200R24**	UNISTEEL G177	GOODYEAR	423	J	18	9370	8450	49.4	Seals tread punctures* and is for rugged off-road conditions like coal fields
6394060126	1200R24**	G288 MSA	GOODYEAR	430	J	18	9370	8540	45.0	Outstanding performance in off-highway rough road conditions
7382150125	12R22.5	G287 MSA	GOODYEAR	482	H	16	7390	6780	43.1	Superior over-the-road performance
7382150162	12R22.5	UNISTEEL G177	GOODYEAR	478	H	16	7390	6780	43.7	Seals tread punctures* and is for rugged off-road conditions like coal fields
7382155419	12R22.5	HSC1	CONTINENTAL	482	H	16	7390	6780	43.0	Coal haulers, logging, construction, waste haulers, and other all-position service
7382158102	12R22.5	G622 RSD	GOODYEAR	482	H	16	7390	6780	43.3	For regional and local high-scrub applications
7382158103	12R22.5	G287 MSA DURASEAL	GOODYEAR	482	H	16	7390	6780	43.1	Puncture-sealing* superior over-the-road performance
7382158105	12R22.5	G282 MSD	GOODYEAR	481	H	16	6610	6005	41.9	Long on-/off-highway performance
7382158107	12R22.5	G661 HSA1	GOODYEAR	484	H	16	7390	6780	42.9	Enhanced toughness for high-scrub applications
7422153253	12R22.5	XZE	MICHELIN	486	H	16	7390	6750	42.6	All-position radial with extra-wide, extra-deep tread designed to help deliver best wear in high scrub applications
7482153208	12R22.5	XZY-3	MICHELIN	483	H	16	7390	6780	42.9	All-position radial designed for exceptional wear and traction in mixed on/off road service
7384240125	12R24.5	G287 MSA	GOODYEAR	463	H	16	7830	7160	44.9	Superior over-the-road performance
7384240162	12R24.5	UNISTEEL G177	GOODYEAR	457	H	16	7830	7160	45.7	Seals tread punctures** and is for rugged off-road conditions like coal fields
7484243208	12R24.5	XZY-3	MICHELIN	461	H	16	7830	7160	44.9	All-position radial designed for exceptional wear and traction in mixed on/off road service
7702490524	295/75R22.5	S581	GENERAL	516	G	14	6175	5675	40.1	Long haul, over-the-highway steering and all-position use

All tires listed are radials.

Availability can change without warning.

\*Seals up to ¼" diameter punctures in the repairable area of the tread. Does not seal sidewall punctures.

\*\*Tubed tires.

# Appendix I

## ● Rear Tire Specifications

# On-Highway Trucks

Feature	Size	Description	Manufacturer	Rev/Mile	Load Range	Ply	Maximum Load Single (lb)	Maximum Load Dual (lb)	Unloaded Diameter (in)	Application
7702540190	315/80R22.5	UNISTEEL G291	GOODYEAR	491	J	18	8270	7610	42.3	All-position tire with wear and traction toughness for rugged metro service
7652543208	315/80R22.5	XZY-3	MICHELIN	486	L	20	9090	8270	42.9	All-position radial designed for exceptional wear and traction in mixed on/off road service
7682543212	315/80R22.5	XZU-S2	MICHELIN	488	L	20	10,000	8270	42.8	All-position tire with high carrying capacity designed for exceptional tread life in high scrub urban applications such as refuse vehicles
7772540125	315/80R22.5	G287 MSA	GOODYEAR	485	L	20	9090	8270	42.8	Superior over-the-road performance
7772540190	315/80R22.5	UNISTEEL G291	GOODYEAR	491	L	20	9090	8270	42.3	All-position tire with wear and traction toughness for rugged metro service
7782548109	315/80R22.5	G289 WHA	GOODYEAR	484	L	20	10,200	9090	43.1	Offers a 68 MPH speed rating and helps provide outstanding performance in waste haul applications
7792545416	315/80R22.5	HSU2+	CONTINENTAL	481	L	20	10,000	9090	43.0	Waste haulers, construction and other on/off highway service
7602653208	385/65R22.5	XZY-3	MICHELIN	491	J	18	9370	—	42.4	All-position radial designed for exceptional wear and traction in mixed on/off road service
7702658113	385/65R22.5	G296 MSA	GOODYEAR	488	J	18	9370	—	42.5	Long mileage super single tire for heavy on- and off-road applications
7792655412	385/65R22.5	HTC1	CONTINENTAL	493	L	20	9920	—	42.0	Super single fitment for steer and trailer positions
7652663208	425/65R22.5	XZY-3	MICHELIN	465	L	20	11,400	—	44.7	All-position radial designed for exceptional wear and traction in mixed on/off road service
7652663267	425/65R22.5	XZL	MICHELIN	467	L	20	11,400	—	44.8	All-terrain, all-position radial for special service such as emergency response vehicles
7752665412	425/65R22.5	HTC1	CONTINENTAL	465	L	20	11,400	—	44.5	Super single fitment for steer and trailer positions
7752668113	425/65R22.5	G296 MSA	GOODYEAR	468	L	20	11,400	—	44.4	Long mileage super single tire for heavy on- and off-road applications
7602673208	445/65R22.5	XZY-3	MICHELIN	455	L	20	12,800	—	45.8	All-position radial designed for exceptional wear and traction in mixed on/off road service
7702678113	445/65R22.5	G296 MSA	GOODYEAR	457	L	20	12,300	—	45.5	Long mileage super single tire for heavy on- and off-road applications

All tires listed are radials.  
Availability can change without warning.

**Front Suspension Specifications**

**Multi Leaf Shackle**

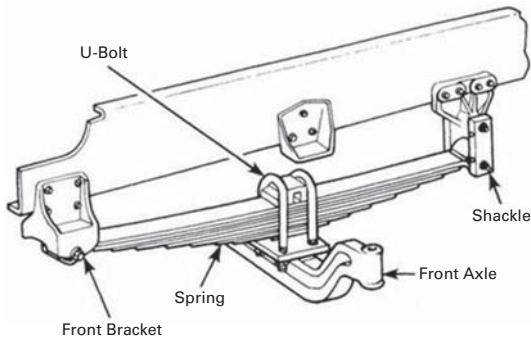

- Improved ride performance.
- Recommended for heavy duty applications (on/off road) 20,000 lb or lower.
- Can be used for heavy duty on-highway applications above 20,000 lb with limited off road.

**Multi Leaf Slipper**

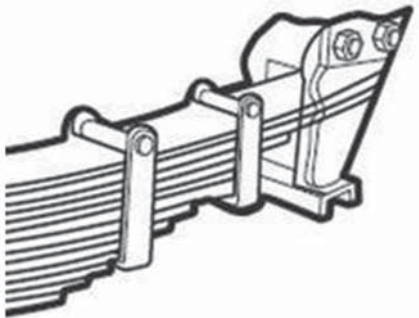

- Most durable.
- Recommended for severe off road applications above 20,000 lb.

**Parabolic Taper Leaf**

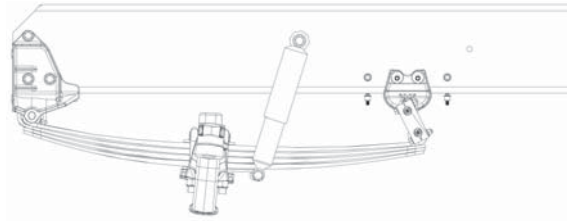

- Best ride.
- Lightest weight.
- Shock absorber required.
- Recommended for heavy duty applications (on/off road) 20,000 lb or lower.

Appendix J  
● Front Suspension Specifications

On-Highway Trucks

Feature Code	Description	CT681	6x4	114	BBC	CT680	6x4	124	BBC	CT660	6x4	116	BBC	CT660	6x4	122	BBC	CT660	4x4	122	BBC	CT660	6x6	122	BBC	CT660	8x6	124	BBC	CT660	8x6	116	BBC	CT660	8x6	122	BBC	Load Rating (lb)	With Shock	Torque Rods
0003ADC	SPRING Parabolic, Taper Leaf	x	x																																		12,000	Y		
0003ADS	SPRING Multi Leaf; 12,000-lb Capacity Left; 10,000-lb Capacity Right; Use with Left Wing Snow Plow																										x	x									12,000			
0003AGD	SUSPENSION, FRONT, SPRING Parabolic, Taper Leaf; 13,200-lb Capacity; with Shock Absorbers																																					13,200	Y	
0003ACH	SPRING Multi Leaf, Shackle																																					14,000	Y	N
0003ADD	SPRING Parabolic, Taper Leaf	x	x																																		14,000	Y		
0003ACP	SPRING Multi Leaf, Shackle																																					16,000	N	N
0003ADE	SPRING Parabolic, Taper Leaf	x	x																																		16,000	Y		
0003ACR	SPRING Multi Leaf, Shackle																																					18,000	N	N
0003ADG	SPRING Parabolic, Taper Leaf	x	x																																		18,000	Y		
0003ADH	SPRING Parabolic, Taper Leaf	x	x																																		18,000	Y		
0003ACS	SPRING Multi Leaf, Shackle																																				20,000	N	N	
0003ACU	SPRING Multi Leaf, Slipper																																				20,000	N	Y	
0003ADR	SPRING Multi Leaf, Slipper, includes (1) Extra Leaf on Right Side																																				20,000		Y	
0003AEB	SPRING Taper Leaf, Shackle; 18,000-lb Capacity Steel Springs with (2) Aeon Rubber Auxiliary Springs (2000-lb Capacity); includes One Extra Leaf and 1.0" Spacer on Left Side	x																																			20,000			
0003AEX	SPRING Two Stage Multi Leaf; Two Stage Steel Springs and (2) Rubber Auxiliary Springs	x	x																																		20,000	Y	N	
0003AGA	SPRING Parabolic, Taper Leaf																																				20,000	Y		
0003AGR	SPRING Multi Leaf, Shackle, Two Stage Spring																																				20,000	N	N	
0003ACW	SPRING Multi Leaf, Slipper																																				21,000	N	Y	
0003ACT	SPRING Multi Leaf, Shackle																																				23,000	N	N	
0003AEP	SPRING Multi Leaf, Shackle; with Special Spacer Blocks for Mixer Application																																				23,000	N	N	
0003ACX	SPRING Multi Leaf, Slipper																																				24,000	N	Y	

Rear Suspension Details

**HENDRICKSON** Walking Beam Suspension

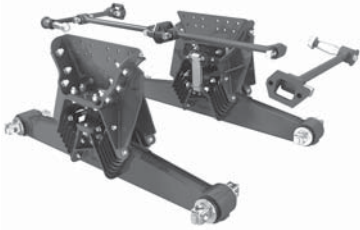

**HAULMAAX/HMX**

- Recommended for dump, refuse, mixer, building /material supply and logging applications.
- Lightweight design for additional payload and route consolidation.
- Reduced maintenance with fewer bushings and no lubrication requirements.
- VariRate spring system provides superior combination of empty ride and loaded stability.
- Up to 17 in of diagonal articulation for greater off-road mobility.
- Capacities of 40,000 and 46,000 lb.

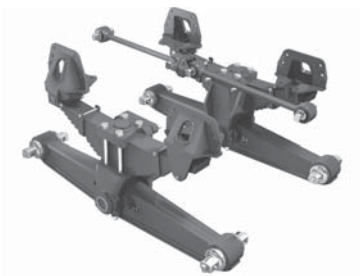

**RT**

- RT Series well suited for dump, refuse and building/material supply.
- Engineered with low maintenance bushings and spring assemblies.
- Operating in the field for over 85 years.
- RT capacities up to 65,000 lb.

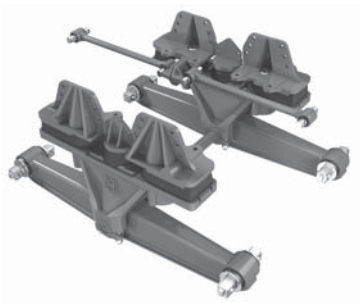

**RS/R**

- Recommended for mining, refuse, logging and other specialty applications.
- R Series solid mount is an extra heavy-duty suspension where maximum roll stability is essential.
- RS rubber load cushions absorb shock and provide high roll stability for severe-service applications.
- Capacities up to 85,000 lb.

## Rear Suspension Details (cont'd)



**Chalmers  
Suspensions**

### Walking Beam Suspension

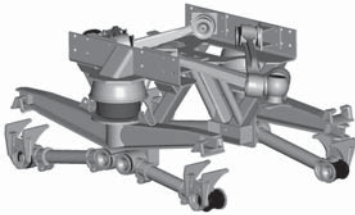

#### 800 Series

- Recommended for all types of applications, mixer, refuse, dump, logging, oilfield, mining, tanker, airport refueler and other vocational applications.
- Lightweight design, minimum maintenance, improved traction on uneven ground because axles do not transfer weight from one axle to the other.
- Loadguard hollow rubber spring is virtually indestructible, variable rate self damping for enhanced ride qualities laden and unladen. Greatly increased stability, combats side sway with wider spring centers.
- Full freedom of articulation both “parallel and diagonal.”
- Capacity range from 40,000 to 52,000 lb.



### Air Suspension

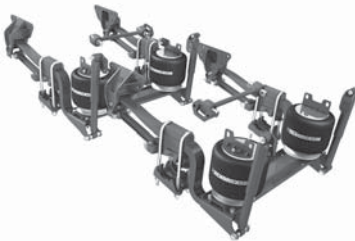

#### HAS

- Suited for both on- and off-highway applications.
- Excellent ride quality.
- Approved for up to 25 percent off-highway use.
- Approved for use with lift axles.
- Optional inboard shocks available.
- Capacities of 40,000 and 46,000 lb.



#### PRIMAAX

- Approved for 100% off-highway use.
- Ideal for heavy-haul, dump, logging, refuse, mixer, building/material supply and crane applications.
- Optimized configuration helps improve handling and roll stiffness for expanded applications.
- Axle connection and torque rods help reduce torsional axle stress and drive-line vibration.
- Large-volume, low frequency air springs provide a smooth ride for on- and off-road usage.
- Up to 12.5 in of diagonal wheel articulation for superior mobility.
- Capacities of 46,000 lb and 52,000 lb.

## Rear Suspension Details (cont'd)



## Air Suspension for Tridem Axles



## AD Series

- 100% off-highway rated performance.
- Designed for maximum durability in challenging operational environments.
- Non-torque reactive design maintains proper pinion angle to reduce unwanted driveline vibration and noise while helping increase driveline component life.
- Proprietary SAF-Holland rubber bushings and Sachs shocks are standard for increased durability and service life.

**Developed for severe duty applications characterized by:**

- Heavy vertical loads
- High gross combined weights
- High torque drive trains
- High center of gravity loads
- Significant off-highway travel

**Severe and Heavy Duty Applications Include:**

- Heavy haul/heavy construction
- Mine/Pit/Quarry
- Logging
- Oilfield
- Mixers and dumps for aggregate
- Asphalt and concrete transfer
- Straight truck in municipal, utility, and maintenance

# Appendix L

## ● Rear Suspension Specifications

# On-Highway Trucks

Feature Code	Description	Axle Spacing (in)							Load Rating (lb)	Air Ride	Walking Beam	Spring	Tandem	Tridem	Axle Spacing (in)
		CT681 6x4 114 BBC	CT680 6x4 124 BBC	CT660 6x4 116 BBC	CT660 6x4 122 BBC	CT660 4x4 122 BBC	CT660 6x6 122 BBC	CT680 8x6 124 BBC							
0014SAP	SINGLE Constant Rate, Double Eye Type, includes 4500-lb Capacity Auxiliary					x			23,000		x	x			
0014SAD	SINGLE Constant Rate, Double Eye Type, includes 4500-lb Capacity Multi Leaf Auxiliary					x			30,000		x	x			
0014UHD	Hendrickson RT-403 with Rubber Center Bushings	x	x	x	x		x		40,000	x			x		54
0014ULA	Hendrickson HAS-402-60 9.5" Ride Height, with Shock Absorbers Mounted in Standard Location	x	x	x	x				40,000	x			x		60
0014ULU	Hendrickson HAS-402-55 9.5" Ride Height, with Shock Absorbers Mounted Inboard	x	x	x	x				40,000	x			x		55
0014ULV	Hendrickson HAS-402-60 9.5" Ride Height, with Shock Absorbers Mounted Inboard	x	x	x	x				40,000	x			x		60
0014ULX	Hendrickson HMX-400-54 with Rubber End Bushings, Transverse Torque Rods, Less Shock Absorbers	x	x	x	x		x		40,000	x			x		54
0014UZS	Chalmers 854-40L with Standard Restrictor Cans, (8) Torque Rods, Less Shocks	x	x	x	x				40,000	x			x		54
0014UKZ	Hendrickson HAS-402-55, 9.5" Ride Height, with Shock Absorbers Mounted in Standard Location	x	x	x	x				40,000	x			x		55
0014VBA	Hendrickson HAS-402-55, 6.5" Ride Height, with Shock Absorbers Mounted Inboard	x	x	x	x				40,000	x			x		55
0014VBC	Hendrickson HAS-402-60, 6.5" Ride Height, with Shock Absorbers Mounted Inboard	x	x	x	x				40,000	x			x		60
0014UHK	Hendrickson RT-463 with Bronze Center Bushings	x	x	x	x		x		46,000	x			x		54
0014UHL	Hendrickson RT-463 with Transverse Torque Rods and Rubber Center Bushings	x	x	x	x		x		46,000	x			x		60
0014ULB	Hendrickson HAS-460-55 9.5" Ride Height, with Shock Absorbers Mounted in Standard Location	x	x	x	x				46,000	x			x		55
0014ULC	Hendrickson HAS-460-60 9.5" Ride Height, with Shock Absorbers Mounted in Standard Location	x	x	x	x				46,000	x			x		60
0014ULS	Hendrickson HAS-460-60 9.5" Ride Height, with Shock Absorbers Mounted Inboard	x	x	x	x				46,000	x			x		60
0014ULT	Hendrickson HAS-460-55 9.5" Ride Height, with Shock Absorbers Mounted Inboard	x	x	x	x				46,000	x			x		55
0014ULY	Hendrickson HMX-460-54 with Rubber End Bushings, Transverse Torque Rods, Less Shock Absorbers	x	x	x	x		x		46,000	x			x		54
0014ULZ	Hendrickson HMX-460-60 with Rubber End Bushings, Transverse Torque Rods, Less Shock Absorbers	x	x	x	x		x		46,000	x			x		60
0014UMC	Hendrickson HMX-460-72.5 with Rubber End Bushings, Transverse Torque Rods, Less Shock Absorbers	x	x	x	x		x		46,000	x			x		73
0014UNW	Hendrickson PAX-460-72 9.0" Ride Height, with Shock Absorbers Mounted in Standard Location	x	x	x	x				46,000	x			x		72
0014UNY	Hendrickson PAX-460-60 9.0" Ride Height, with Shock Absorbers Mounted in Standard Location	x	x	x	x				46,000	x			x		60
0014UZB	Chalmers 854-46H-HS with High Stability (HS) Restrictor Cans and (8) Torque Rods Less Shocks	x	x	x	x				46,000	x			x		54
0014UZT	Chalmers 860-46H-HS with High Stability (HS) Restrictor Cans, (8) Torque Rods, Less Shocks	x	x	x	x				46,000	x			x		60
0014UZU	Chalmers 854-46H with Standard Restrictor Cans, (8) Torque Rods, Less Shocks	x	x	x	x				46,000	x			x		54
0014UZV	Chalmers 860-46H with Standard Restrictor Cans, (8) Torque Rods, Less Shocks	x	x	x	x				46,000				x		60
0014UZW	Chalmers 872-46H-HS with High Stability Restrictor Cans, (8) Torque Rods, Less Shocks	x	x	x	x				46,000	x			x		72
0014VBE	Hendrickson HAS-460-55, 6.5" Ride Height, with Shock Absorbers Mounted Inboard	x	x	x	x				46,000	x			x		55
0014VBH	Hendrickson HAS-460-60, 6.5" Ride Height, with Shock Absorbers Mounted Inboard	x	x	x	x				46,000	x			x		60
0014698	Hendrickson RT-523 with Bronze Center Bushings	x	x	x	x		x		52,000	x			x		54
0014UZX	Chalmers 854-52-H-HS with High Stability Restrictor Cans, (8) Torque Rods, Less Shocks	x	x	x	x				52,000	x			x		54
0014UNX	Hendrickson PAX-460-55, 9.0" Ride Height, with Shock Absorbers Mounted in Standard Location	x	x	x	x				52,000	x			x		55
0014UPU	Hendrickson PAX-520-60, 10.0" Ride Height, with Shock Absorbers Mounted in Standard Location	x	x	x	x				52,000	x			x		60
0014UPV	Hendrickson PAX-520-55, 9.0" Ride Height, with Shock Absorbers Mounted in Standard Location	x	x	x	x				52,000	x			x		55
0014UPW	Hendrickson PAX-520-60, 9.0" Ride Height, with Shock Absorbers Mounted in Standard Location	x	x	x	x				52,000	x			x		60
0014UPX	Hendrickson PAX-520-55, 10.0" Ride Height, with Shock Absorbers Mounted in Standard Location	x	x	x	x				52,000	x			x		55
0014524	Hendrickson RT-650 with Rubber Center Bushings	x	x	x	x		x		65,000	x			x		56
0014VKD	Neway AD-369 10.00" Ride Height, with Shock Absorbers							x	69,000	x				x	55
0014VKE	Neway AD-378 10.00" Ride Height, with Shock Absorbers							x	78,000	x				x	55
0014UJE	Hendrickson R-700, Solid Mount Less Transverse Torque Rods	x	x	x	x				80,000	x			x		60
0014UNR	Hendrickson RS-850 Less Transverse Torque Rods and with Rubber Load Cushions, with 9.75" Ride Height and 35.875" Frame Width	x	x	x	x		x		85,000	x			x		60



**Power Take Off Specifications**  
**Rear Engine PTO for CT13 Engines**

Engine RPM	REPTO RPM	REPTO Torque (lbf-ft)	REPTO HP
800	1021	479	92
900	1148	479	105
1000	1276	479	117
1100	1404	479	128
1200	1531	479	140
1300	1659	479	151
1400	1786	479	163
1500	1914	479	175
1600	2042	479	186
1700	2169	479	198

**NOTE:** 6 bolt circle, CCW rotation.

**Front Engine PTO (CT681)**

Engine RPM	FEPTO RPM	FEPTO Torque (lbf-ft)	FEPTO HP
800	800	479	73
900	900	479	82
1000	1000	479	91
1100	1100	479	100
1200	1200	479	109
1300	1300	479	119
1400	1400	479	128
1500	1500	479	137
1600	1600	479	146
1700	1700	479	155

**NOTE:** 4 bolt circle, CW rotation.

**CX31 Automatic Transmission Power Take Off Ports**

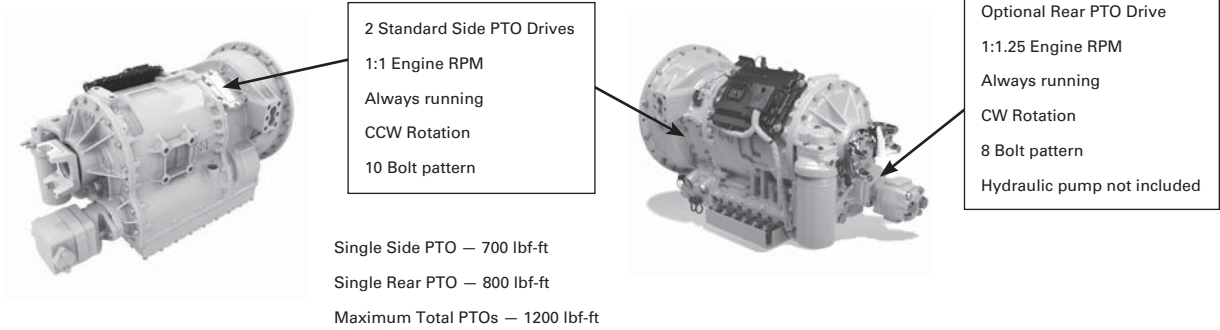

**Side PTOs**

Engine RPM	PTO RPM	Torque (lbf-ft)	HP
800	800	700	107
900	900	700	120
1000	1000	700	133
1100	1100	700	147
1200	1200	700	160
1300	1300	700	173
1400	1400	700	187
1500	1500	700	200
1600	1600	700	213
1700	1700	700	227
1800	1800	700	240
1900	1900	700	253
2000	2000	700	267
2100	2100	700	280

**Optional Rear Thru-Shaft PTOs**

Engine RPM	PTO RPM	Torque (lbf-ft)	HP
800	1000	800	152
900	1125	800	171
1000	1250	800	190
1100	1375	800	209
1200	1500	800	228
1300	1625	800	248
1400	1750	800	267
1500	1875	800	286
1600	2000	800	305
1700	2125	800	324
1800	2250	800	343
1900	2375	800	362
2000	2500	800	381
2100	2625	800	400



# PAVING PRODUCTS

## CONTENTS

### COLD PLANERS

Sustainability . . . . .	13-1
Features . . . . .	13-1
Specifications . . . . .	13-2
Production Estimating . . . . .	13-3
Machine Selection . . . . .	13-5
Cold Planing Fundamentals . . . . .	13-5
Applications . . . . .	13-7
Cold Planer Use by Project Type . . . . .	13-8

### ROTARY MIXERS

Sustainability . . . . .	13-9
Features . . . . .	13-9
Specifications . . . . .	13-10
Optional Equipment . . . . .	13-11
Production Estimating . . . . .	13-11
Weight of Materials . . . . .	13-12
Stabilization/Reclamation Production . . . . .	13-12

### ASPHALT PAVERS

Sustainability . . . . .	13-13
Features . . . . .	13-13
Specifications . . . . .	13-14
Screeds . . . . .	13-18
Production Table . . . . .	13-20
Slope Conversion Table/ Inches in Decimals Table . . . . .	13-21

### VIBRATORY AND PNEUMATIC TIRE COMPACTORS

Sustainability . . . . .	13-22
Features . . . . .	13-22
Specifications: Vibratory Compactors . . . . .	13-23
Pneumatic Tire Compactors . . . . .	13-37
Pneumatic Tires: Inflation Pressures . . . . .	13-38
Ballast Configurations . . . . .	13-38
Maximum Ground Pressures . . . . .	13-39
Ground Contact Pressures . . . . .	13-39
Production Estimating: Vibratory Compactors . . . . .	13-41
Pneumatic Tire Compactors . . . . .	13-45

### Cold Planer

#### Sustainability:

- **Long-lasting lubricants and fluids** extend maintenance intervals, decreasing the amount of waste and filters contributed to environment.
- **Superior Cat® cutting tools last longer**, providing higher daily productivity with less fuel burn.
- **Available Cat Diamond Cutting Bits** last up to 80 times longer than conventional carbide bits.
- **Ecology drains** provide a simple means to drain machine fluids with a minimized risk of spillage.
- **Maintenance free Cat batteries** are recyclable.
- **Cat ACERT™ engines** meet applicable emission standards.
- **Cold planers recycle aggregate from worn out roads** for use in new roads, reducing the cost and energy needs required for excavating, processing and hauling virgin aggregate.

#### Features:

- **Cat ACERT engines.**
- **Up-cutting mandrels** provide cutting efficiency and improved bit life.
- **Excellent maneuverability** for productivity and job site flexibility.
- **Front-discharge conveyor** facilitates haul unit movement in congested urban applications.
- **Optimum weight-to-horsepower balance** for delivering maximum available horsepower to the cutter.
- **Computerized Monitoring System (CMS)** provides three warning levels for abnormal operating conditions.
- **Load control system** keeps machine operating at peak efficiency.
- **Water spray system** for dust control and bit cooling.
- **Optional Cat Grade and Slope** available for PM620 and PM622 models.

<b>MODEL</b>	<b>PM102</b>		<b>PM620</b>		<b>PM622</b>	
Gross Power	168 kW	<b>225 hp</b>	470 kW	<b>630 hp</b>	470 kW	<b>630 hp</b>
Operating Weight	17 600 kg	<b>38,810 lb</b>	33 330 kg	<b>73,260 lb</b>	33 900 kg	<b>74,580 lb</b>
Engine Model	<b>C7 ACERT</b>		<b>C18 ACERT</b>		<b>C18 ACERT</b>	
Emission Standards	<b>U.S. EPA Tier 3/ EU Stage IIIA equivalent</b>		<b>Tier 4 Final/ Stage IV</b>		<b>Tier 4 Final/ Stage IV</b>	
Rated Engine RPM	<b>2200</b>		<b>1900</b>		<b>1900</b>	
No. of Cylinders	<b>6</b>		<b>6</b>		<b>6</b>	
Drive Systems: Rotor	<b>Mechanical</b>		<b>Mechanical</b>		<b>Mechanical</b>	
Ground	<b>Hydrostatic with 4 track design</b>		<b>Hydrostatic with 4 track design</b>		<b>Hydrostatic with 4 track design</b>	
Discharge Conveyor Width	600 mm	<b>23.6"</b>	850 mm	<b>33.5"</b>	850 mm	<b>33.5"</b>
Width of Standard Track Shoe	225 mm	<b>8.8"</b>	305 mm	<b>12"</b>	305 mm	<b>12"</b>
Track Length	720 mm	<b>28.3"</b>	788 mm	<b>70.4"</b>	788 mm	<b>70.4"</b>
Operating Dimensions:						
Height	3400 mm	<b>11'2"</b>	4050 mm	<b>13'4"</b>	4050 mm	<b>13'4"</b>
Width	2500 mm	<b>8'2"</b>	2790 mm	<b>9'2"</b>	2790 mm	<b>9'2"</b>
Length	10 700 mm	<b>35'1"</b>	14 520 mm	<b>47'7"</b>	14 520 mm	<b>47'7"</b>
Shipping Dimensions:						
Height	3100 mm	<b>10'1"</b>	3000 mm	<b>9'11"</b>	3000 mm	<b>9'11"</b>
Width	2500 mm	<b>8'2"</b>	2500 mm	<b>8'3"</b>	2700 mm	<b>10'10"</b>
Length	8500 mm	<b>27'8"</b>	12 430 mm	<b>40'10"</b>	12 430 mm	<b>40'10"</b>
Standard Mandrel (Width of Cut)	1000 mm	<b>40"</b>	2010 mm	<b>79.1"</b>	2235 mm	<b>88"</b>
No. of Teeth	<b>97</b>		<b>178</b>		<b>193</b>	
Depth of Cut (Max.)	305 mm	<b>12"</b>	330 mm	<b>13"</b>	330 mm	<b>13"</b>
Speeds: Operating (Max.)						
Track undercarriage	27 m/min	<b>89 ft/min</b>	100 m/min	<b>328 ft/min</b>	100 m/min	<b>328 ft/min</b>
Wheel undercarriage	46 m/min	<b>151 ft/min</b>	—	—	—	—
Speeds: Travel (Max.)						
Track undercarriage	4.1 km/h	<b>2.5 mph</b>	5.9 km/h	<b>3.7 mph</b>	5.9 km/h	<b>3.7 mph</b>
Wheel undercarriage	6.4 km/h	<b>3.9 mph</b>	—	—	—	—
Inside Turning Radius: Right						
Track undercarriage	3450 mm	<b>11'3"</b>	2000 mm	<b>6'7"</b>	1800 mm	<b>5'11"</b>
Wheel undercarriage	2100 mm	<b>6'8"</b>	—	—	—	—
Fuel Capacity	400 L	<b>105 U.S. gal</b>	1108 L	<b>288.1 U.S. gal</b>	1108 L	<b>288.1 U.S. gal</b>
Diesel Exhaust Fluid Refill Capacity	—	—	47 L	<b>12.2 U.S. gal</b>	47 L	<b>12.2 U.S. gal</b>
Water Capacity	1060 L	<b>280 U.S. gal</b>	3400 L	<b>898 U.S. gal</b>	3400 L	<b>898 U.S. gal</b>

Speed		Cutter/Drum Width — m <sup>2</sup> /min (yd <sup>2</sup> /min)									
		350 mm (1'2")		400 mm (1'4")		500 mm (1'8")		600 mm (2'0")		1000 mm (3'4")	
m/min	ft/min	m <sup>2</sup>	yd <sup>2</sup>	m <sup>2</sup>	yd <sup>2</sup>	m <sup>2</sup>	yd <sup>2</sup>	m <sup>2</sup>	yd <sup>2</sup>	m <sup>2</sup>	yd <sup>2</sup>
3.0	10	1.1	1.3	1.2	1.4	1.5	1.8	1.8	2.2	3.0	3.6
4.6	15	1.6	1.9	1.8	2.2	2.3	2.8	2.8	3.3	4.6	5.5
6.1	20	2.1	2.6	2.4	2.9	3.1	3.6	3.7	4.4	6.1	7.3
7.6	25	2.7	3.2	3.0	3.6	3.8	4.5	4.6	5.5	7.6	9.1
9.1	30	3.2	3.8	3.6	4.4	4.6	5.4	5.5	6.5	9.1	10.9
10.7	35	3.7	4.5	4.3	5.1	5.4	6.4	6.4	7.7	10.7	12.8
12.2	40	4.3	5.1	4.9	5.8	6.1	7.3	7.3	8.8	12.2	14.6
13.7	45	4.8	5.7	5.5	6.6	6.9	8.2	8.2	9.8	13.7	16.4
15.2	50	5.3	6.4	6.1	7.3	7.6	9.1	9.1	10.9	15.2	18.2
16.8	55	5.9	7.0	6.7	8.0	8.4	10.0	10.1	12.1	16.8	20.1
18.3	60	6.4	7.7	7.3	8.8	9.2	10.9	11.0	13.1	18.3	21.9
Speed		1220 mm (4'0")		1900 mm (6'3")		2010 mm (6'7")		2100 mm (6'11")		2210 mm (7'3")	
m/min	ft/min	m <sup>2</sup>	yd <sup>2</sup>	m <sup>2</sup>	yd <sup>2</sup>	m <sup>2</sup>	yd <sup>2</sup>	m <sup>2</sup>	yd <sup>2</sup>	m <sup>2</sup>	yd <sup>2</sup>
3.0	10	3.7	4.4	5.7	6.8	6.0	7.2	6.3	7.5	6.6	7.9
4.6	15	5.6	6.7	8.7	10.5	9.2	11.1	9.7	11.6	10.2	12.2
6.1	20	7.4	8.9	11.6	13.9	12.3	14.7	12.8	15.3	13.5	16.1
7.6	25	9.3	11.1	14.4	17.3	15.3	18.3	16.0	19.1	16.8	20.1
9.1	30	11.1	13.3	17.3	20.7	18.3	21.9	19.1	22.9	20.1	24.1
10.7	35	13.1	15.6	20.3	24.3	21.5	25.7	22.5	26.9	23.6	28.3
12.2	40	14.9	17.8	23.2	27.7	24.5	29.3	25.6	30.6	27.0	32.2
13.7	45	16.7	20.0	26.0	31.1	27.5	32.9	28.8	34.4	30.3	36.2
15.2	50	18.5	22.2	28.9	34.5	30.6	36.5	31.9	38.2	33.6	40.2
16.8	55	20.5	24.5	31.9	38.2	33.8	40.4	35.3	42.2	37.1	44.4
18.3	60	22.3	26.7	34.8	41.6	36.8	44.0	38.4	46.0	40.4	48.4
Speed		3050 mm (10'0")		3500 mm (11'6")		3810 mm (12'6")					
m/min	ft/min	m <sup>2</sup>	yd <sup>2</sup>	m <sup>2</sup>	yd <sup>2</sup>	m <sup>2</sup>	yd <sup>2</sup>				
3.0	10	9.2	10.9	10.5	12.6	11.4	13.7				
4.6	15	14.0	16.8	16.1	19.3	17.5	21.0				
6.1	20	18.6	22.3	21.4	25.5	23.2	27.8				
7.6	25	23.2	27.7	26.6	31.8	29.0	34.6				
9.1	30	27.8	33.2	31.9	38.1	34.7	41.5				
10.7	35	32.6	39.0	37.5	44.8	40.8	48.8				
12.2	40	37.2	44.5	42.7	51.1	46.5	55.6				
13.7	45	41.8	50.0	48.0	57.3	52.2	62.4				
15.2	50	46.4	55.4	53.2	63.6	57.9	69.3				
16.8	55	51.2	61.3	58.8	70.3	64.0	76.6				
18.3	60	55.8	66.8	64.1	76.6	69.7	83.4				

NOTE: Above figures are based on approximately 25 mm (1 in) depth of cut. For greater depths of cut, multiply the production rate by cutting depth. Figures are based on asphalt density of 2322 kg/m<sup>3</sup> (145 lb/ft<sup>3</sup>). (As referenced on *AsphaltPavement.org* — the website of NAPA.)

Speed		Cutter/Drum Width — metric tons/min (U.S. tons/min)									
		350 mm (1'2")		400 mm (1'4")		500 mm (1'8")		600 mm (2'0")		1000 mm (3'4")	
m/min	ft/min	Metric tons	U.S. tons	Metric tons	U.S. tons	Metric tons	U.S. tons	Metric tons	U.S. tons	Metric tons	U.S. tons
3.0	10	0.06	0.07	0.07	0.08	0.09	0.10	0.10	0.12	0.17	0.19
4.6	15	0.09	0.10	0.11	0.12	0.13	0.15	0.16	0.18	0.27	0.29
6.1	20	0.12	0.14	0.14	0.16	0.18	0.20	0.21	0.23	0.35	0.39
7.6	25	0.15	0.17	0.18	0.19	0.22	0.24	0.26	0.29	0.44	0.49
9.1	30	0.18	0.20	0.21	0.23	0.26	0.29	0.32	0.35	0.53	0.58
10.7	35	0.22	0.24	0.25	0.27	0.31	0.34	0.37	0.41	0.62	0.68
12.2	40	0.25	0.27	0.28	0.31	0.35	0.39	0.42	0.47	0.71	0.78
13.7	45	0.28	0.31	0.32	0.35	0.40	0.44	0.48	0.53	0.80	0.88
15.2	50	0.31	0.34	0.35	0.39	0.44	0.49	0.53	0.58	0.88	0.97
16.8	55	0.34	0.38	0.39	0.43	0.49	0.54	0.59	0.64	0.98	1.07
18.3	60	0.37	0.41	0.42	0.47	0.53	0.59	0.64	0.70	1.06	1.17
Speed		1220 mm (4'0")		1900 mm (6'3")		2010 mm (6'7")		2100 mm (6'11")		2210 mm (7'3")	
		Metric tons	U.S. tons	Metric tons	U.S. tons	Metric tons	U.S. tons	Metric tons	U.S. tons	Metric tons	U.S. tons
3.0	10	0.21	0.23	0.33	0.36	0.35	0.39	0.37	0.40	0.38	0.42
4.6	15	0.33	0.36	0.51	0.56	0.54	0.59	0.56	0.62	0.59	0.65
6.1	20	0.43	0.48	0.67	0.74	0.71	0.78	0.74	0.82	0.78	0.86
7.6	25	0.54	0.59	0.84	0.92	0.89	0.98	0.93	1.02	0.98	1.07
9.1	30	0.64	0.71	1.00	1.11	1.06	1.17	1.11	1.22	1.17	1.29
10.7	35	0.76	0.84	1.18	1.30	1.25	1.38	1.30	1.44	1.37	1.51
12.2	40	0.86	0.95	1.35	1.48	1.42	1.57	1.49	1.64	1.57	1.72
13.7	45	0.97	1.07	1.51	1.67	1.60	1.76	1.67	1.84	1.76	1.94
15.2	50	1.08	1.19	1.68	1.85	1.77	1.95	1.85	2.04	1.95	2.15
16.8	55	1.19	1.31	1.85	2.04	1.96	2.16	2.05	2.26	2.16	2.38
18.3	60	1.30	1.43	2.02	2.22	2.14	2.35	2.23	2.46	2.35	2.59
Speed		3050 mm (10'0")		3500 mm (11'6")		3810 mm (12'6")					
		Metric tons	U.S. tons	Metric tons	U.S. tons	Metric tons	U.S. tons				
3.0	10	0.53	0.59	0.61	0.67	0.66	0.73				
4.6	15	0.81	0.90	0.93	1.03	1.02	1.12				
6.1	20	1.08	1.19	1.24	1.37	1.35	1.49				
7.6	25	1.35	1.48	1.54	1.70	1.68	1.85				
9.1	30	1.61	1.78	1.85	2.04	2.01	2.22				
10.7	35	1.89	2.09	2.17	2.40	2.37	2.61				
12.2	40	2.16	2.38	2.48	2.73	2.70	2.97				
13.7	45	2.43	2.67	2.78	3.07	3.03	3.34				
15.2	50	2.69	2.97	3.09	3.40	3.36	3.70				
16.8	55	2.97	3.28	3.41	3.76	3.72	4.09				
18.3	60	3.24	3.57	3.72	4.10	4.05	4.46				

NOTE: Above figures are based on approximately 25 mm (1 in) depth of cut. For greater depths of cut, multiply the production rate by cutting depth. Figures are based on asphalt density of 2322 kg/m<sup>3</sup> (145 lb/ft<sup>3</sup>). (As referenced on *AsphaltPavement.org* — the website of NAPA.)

## MACHINE SELECTION

Prime considerations in selecting the proper cold planer model are:

- specifics of work to be done
- type of projects generally done by the contractor
  - City/Urban or Highway/Airport
- desired production capacities

### PM102 Cold Planer

The Cat PM102 Cold Planer features compact dimensions and excellent maneuverability ideal for easy operation in urban applications. The machine performs controlled, full-depth removal of asphalt layers in a single pass and is also capable of concrete removal. The machine is available with a wheel or track undercarriage and features four steering modes for high maneuverability.

### PM620 and PM622 Cold Planers

The Cat PM620 and PM622 Cold Planers are high-production, half-lane milling machines with excellent maneuverability and plenty of power to perform controlled full-depth removal of asphalt and concrete pavements in a single pass. The track-driven machine features four steering modes for high maneuverability. The PM620 features a 2.0 m (79") cutting width and performs well in urban environments or in applications where great maneuverability is required. The PM622 features a 2.2 m (88") cutting width and is ideal for high-production applications such as main line milling.

### Cold Planer Characteristics (Highway/Airport)

Highway/Airport work requires high-volume cold planers. The PM620, PM622 and other high horsepower half-lane cold planers are being used more on Highway/Airport projects. Users like to have one machine that can work successfully on high production jobs then switch to city/urban applications.

### Cold Planer Characteristics (City/Urban)

All Cat cold planers are four-track, front discharge models. Front discharge cold planers make traffic control easier in congested quarters. The trucks travel forward in the same direction as the cold planer. The trucks move in and out of traffic faster increasing production.

## COLD PLANING FUNDAMENTALS

### Definition

Cold planing is automatically controlled cold milling to restore the pavement surface to a specified grade and slope; remove bumps, ruts, and other imperfections; and leave a textured surface which can be opened immediately to traffic or overlaid with new pavement materials.

### Production and Tooth Wear

Because pavement materials vary, so do production and tooth wear. While predicting the exact production rate and tooth wear on a particular job is difficult, general guidelines are available.

Production depends on the milling rate (the speed at which the cold planer moves forward). The machine's forward speed is determined, primarily, by aggregate type, asphalt bond strength and depth of cut. When milling asphalt pavement, the cold planer's teeth essentially are breaking the bond between asphalt-coated aggregate, not actually fracturing the aggregate itself. A pavement made with a mix containing a high percentage of fine aggregate and a high asphalt content is more difficult to mill than a pavement with a high percentage of coarse aggregate.

A dense or fine mix usually requires more power at the cutting drum, limiting the cold planer's forward speed. Decreased speed lowers production, and the tough bond between the small aggregate particles causes increased cutting-tooth wear. Lower production and higher tooth wear result in increased unit costs.

Cutting depth affects power demand at the drum and helps determine the cold planer's forward speed. However, production increases, to a point, as the depth of cut increases. For example, changing from a 25 mm (1 in) cut to a 51 mm (2 in) cut slows the machine only slightly but doubles the amount of material produced.

As the cut increases beyond the machine's peak-production depth, the reduced forward speed begins to offset the production gains of the deeper cut. For example, production at a 152 mm (6 in) cutting depth and slow speed may be no greater than cutting at a 76 mm (3 in) depth and a much faster speed.



**Low Density Asphalt**

Depth		PM620, PM622	
mm	in	m/min	ft/min
51	2	40	130
101	4	32	105
127	5	21	70
178	7	12	40
254	10	6	20
305	12	5	15

**High Density Asphalt**

Depth		PM620, PM622	
mm	in	m/min	ft/min
51	2	32	105
101	4	26	85
127	5	18	60
178	7	9	30
254	10	5	15
305	12	4	12

As long as the cold planer maintains a productive forward speed, deeper cuts will yield greater production and tend to lower tooth cost. Tooth wear does not increase in direct proportion to production when the machine is working in an efficient range.

Tooth wear at various depths for a given material is affected by how long the tooth remains in the cut. Because the teeth are mounted on a circular drum, each tooth cuts through the pavement in an arc. The tooth arc at a 102 mm (4 in) cutting depth, however, is not four times longer than at a 25 mm (1 in) cutting depth, even though production may be four times greater. The cutting arc at 102 mm (4 in) is approximately twice as long as that at 25 mm (1 in).

The peak cutting depth for a particular cold planer on a specific job is best determined by examining production, and subsequent costs, of a single deep cut versus multiple passes at a shallow depth.

## APPLICATIONS

Although new applications for cold planers are being discovered, most work can be classified in six general categories:

### Leveling and Bonding

This application removes a layer of pavement to eliminate potholes, ruts, bumps and other surface imperfections. The cold planer leaves a level, textured surface ideal for bonding to a new, thin overlay of asphalt or concrete. The surface has an interlocking texture with double the bonding area of a conventional smooth pavement. The textured surface and overlay form a monolithic bond, eliminating the shear plane that causes pavement layers to move and separate. Thinner overlays can be used, making the technique more economical than traditional overlay methods.

### Surface Refinishing

Rough pavement can also be cold planed to specified grade and slope, providing a new riding surface without adding new paving materials. This application is particularly useful when base and sub-base are in good shape, or when several layers have been added to the roadway over the years. Roads can be cold planed during cold, wet months and reopened immediately. New overlays can be added whenever weather permits. This lengthens the practical working season for many contractors. The cold planer can also be used to correct expansion joint faults and pavement cracks.

### Surface Repair

This category generally requires deeper cutting than leveling. It consists of removing isolated distressed pavement sections down to subbase, if necessary, prior to adding new overlay materials. Since the cutter mandrel on Cat cold planers cuts forward and upward, there's no damaging impact to the underlying base.

### Pavement Removal

Pavement buildup is a problem that plagues most older streets, roads and highways. As overlays are added, curbs and drains are buried — creating drainage problems. Overhead clearances are dangerously reduced ... and additional weight is added to over-passes and bridges. Cold planing is an economical method of curing all these problems.

### Surface Texturing

Serious accidents increase when pavement becomes slick from wear. The textured surface produced by cold planing is highly skid-resistant and has dramatically reduced hydroplaning characteristics.

### Pavement Mining

Cold milling has made it practical to actually “mine” deteriorated pavement materials from existing roads and streets. The cold planer produces an ideally-sized asphalt or concrete material which can be recycled in a variety of ways. Depending on type, age and condition of pavement, the largest cold planer can reclaim up to 900 tons of material per hour.

## COLD PLANER USE BY PROJECT TYPE

Applications	Highway/Airport	City/Urban
Planing (Milling)	<ul style="list-style-type: none"> <li>● To establish grade and slope.</li> <li>● Remove excess pavement.</li> </ul>	<ul style="list-style-type: none"> <li>● To establish proper grade and slope.</li> <li>● To establish new grade and slope.</li> </ul>
Partial Removal	<ul style="list-style-type: none"> <li>● For use with hot mix recycle.</li> <li>● Remove pavement irregularities.</li> <li>● Texture for skid resistance.</li> </ul>	<ul style="list-style-type: none"> <li>● To correct drainage and curb reveal.</li> <li>● To lower elevation at overpass.</li> <li>● For use with hot recycle.</li> <li>● Eliminate leveling course.</li> </ul>
Full Depth Removal	<ul style="list-style-type: none"> <li>● Total rebuild. RAP used for base or hot recycle.</li> <li>● Cold recycle. This requires additional surface treatment.</li> </ul>	<ul style="list-style-type: none"> <li>● Total rebuild. RAP used for base or hot recycle.</li> <li>● Cold recycle. Requires additional surface treatment.</li> </ul>
Texturing	<ul style="list-style-type: none"> <li>● For skid resistance and improved bond when overlay is applied.</li> </ul>	<ul style="list-style-type: none"> <li>● For skid resistance and improved bond when overlay is applied.</li> </ul>
Leveling		<ul style="list-style-type: none"> <li>● At intersections to remove bumps, shoving and improve drainage.</li> </ul>
Special	<ul style="list-style-type: none"> <li>● Joint and crack repair.</li> <li>● Cut rumble grooves on shoulders of bridge approaches.</li> <li>● Concrete removal.</li> </ul>	<ul style="list-style-type: none"> <li>● Intersection defect repair.</li> <li>● Pothole repair.</li> <li>● Railroad crossing repair.</li> <li>● Tight radius profiling around manhole covers, etc.</li> <li>● Pavement adjustments (transitions from existing pavements to new overlays).</li> </ul>

**RM300 and RM500B:**

The RM300 and the RM500B combine superior performance and reliability to achieve the most demanding job specifications while maximizing machine uptime. With many enhanced features and options, the RM300 and the RM500B are designed to work well in both full depth reclamation and soil stabilization applications.

**Rotary Mixers****Sustainability:**

- Long-lasting lubricants and fluids extend maintenance intervals, decreasing the amount of waste and filters contributed to environment.
- Ecology drains provide a simple means to drain machine fluids with a minimized risk of spillage.
- Maintenance free Cat batteries are recyclable.
- Cat ACERT engines meet applicable emission standards.
- Rotary Mixers recycle the materials into aggregate on site. That reduces overall fuel consumption and engine emissions.
- Rotary Mixers and the reclamation process can eliminate the need for an excavator and motor grader at most job sites.
- Rotary Mixers can reclaim and stabilize simultaneously. If stabilization is required, the agent can be placed on top of the reclamation project. The Rotary Mixer then makes a single pass, mixing the stabilizer with the material beneath the surface. At the same time, it reduces the aggregate to its original size. All this is accomplished with one machine — in one pass.
- The reclamation and stabilization process can easily incorporate environmentally sensitive sealants. Now the life of the road bases can be extended without fear of harming wildlife.

- The reclamation process usually is quicker than full replacement, allowing roads to open sooner. This means fewer traffic jams — a quality of life issue as well.
- Reclamation and stabilization dramatically extend the life of roads. Some contractors conservatively estimate that a reclaimed/stabilized base will help a recycled road last 30 to 40 years. Extending that life is an enormous cost-saver, and also results in the use of less energy.

**RM300 Features:**

- **Maximum Production** ... from Cat ACERT engines.
- **Highly Efficient** ... load-sensing propel system helps prevent overloading while allowing continuous work near rated horsepower.
- **Extremely Versatile** ... interchangeable rotors provide both reclamation and stabilization capabilities.
- **Consistent Blending** ... automatic depth control, mid-mounted mixing chamber and multi-speed rotor drive combine for optimum blending and increased production.

**RM500B Features:**

- **Maximum Production** ... from Cat ACERT engines.
- **Highly Maneuverable** ... separate hydraulic pump provides hydraulic flow to large displacement motors on each rear wheel.
- **Versatility** ... choice of three rotors for full depth reclamation or soil stabilization.
- **Reliability** ... field proven Cat components maximize machine availability.
- **Standard all-wheel drive with advanced traction control system** for maximum traction.
- **Rotating operator's station with handwheel steering and integrated touchscreen display** provides operator with fingertip control, high visibility and exceptional comfort.

MODEL	RM300		RM500B	
Gross Power	261 kW	<b>350 hp</b>	407 kW*	<b>546 hp*</b>
Operating Weight with ROPS, cab and universal rotor	24 454 kg	<b>53,911 lb</b>	28 553 kg	<b>62,950 lb</b>
Engine Model	<b>C11 ACERT</b>		<b>C15 ACERT</b>	
Emission Standards	<b>Tier 3/Stage IIIA equivalent</b>		<b>Tier 4 Final/Stage IV*</b>	
Rated Engine RPM	<b>1800</b>		<b>2000</b>	
No. Cylinders	<b>6</b>		<b>6</b>	
Bore	130 mm	<b>5.1"</b>	137.2 mm	<b>5.4"</b>
Stroke	140 mm	<b>5.5"</b>	171.4 mm	<b>6.75"</b>
Displacement	11.1 L	<b>680 in<sup>3</sup></b>	15.1 L	<b>921.5 in<sup>3</sup></b>
Drive Systems: Rotor	<b>3 Speed Chain</b>		<b>3 Speed Chain</b>	
Propel	<b>Hydrostatic/Planetary</b>		<b>Hydrostatic/Planetary</b>	
Operating Dimensions: Height	3500 mm	<b>11'6"</b>	3480 mm	<b>11'4"</b>
Width	3000 mm	<b>9'10"</b>	2980 mm	<b>9'7"</b>
Length	10 000 mm	<b>32'10"</b>	10 320 mm	<b>33'10"</b>
Width of Cut	2438 mm	<b>8'0"</b>	2438 mm	<b>8'0"</b>
Depth of Cut (Max.)	457 mm	<b>18"</b>	508 mm	<b>20"</b>
Rotor Speed	<b>@ 1800 engine rpm</b>		<b>@ 2000 engine rpm</b>	
	First	106 rpm	First	115 rpm
	Second	144 rpm	Second	160 rpm
	Third	216 rpm	Third	215 rpm
Minimum Turning Radius:				
Standard	3900 mm	<b>12'10"</b>	4330 mm	<b>14'2"</b>
Travel Speed (Max.): Working	4.3 km/h	<b>2.7 mph</b>	3.3 km/h	<b>2 mph</b>
Roading	9.7 km/h	<b>6.0 mph</b>	10.5 km/h	<b>6.5 mph</b>
Standard Tires: Front	<b>28.1 × 26 18-ply Lug Type R-1</b>		<b>725/70-25 — L-4</b>	
Rear	<b>18.4 × 30 12-ply Lug Type R-1</b>		<b>23.1-26 LS-2</b>	
Fuel Capacity	1056 L	<b>279 U.S. gal</b>	1506 L	<b>279 U.S. gal</b>
Diesel Exhaust Fluid Refill Capacity	—		46 L	<b>12.2 U.S. gal</b>
Cooling System	62.5 L	<b>16.5 U.S. gal</b>	80 L	<b>21.1 U.S. gal</b>
Crankcase	32 L	<b>8.5 U.S. gal</b>	34 L	<b>8.9 U.S. gal</b>

\*402 kW (540 hp), Tier 3/Stage IIIA equivalent emission standards in some markets.

**Rotor Options for RM300 and RM500B**

Rotor	Maximum Depth of Work	No. of Bits/Tools	Direction of Cut	Stabilization	Reclamation
Universal 406 mm (16")*	406 mm 16"	200	Up	X	X
Universal 457 mm (18")**	457 mm 18"	200	Up	X	X
Soil	508 mm 20"	238	Up	X	
Combination	508 mm 20"	114	Up	X	
Spade	457 mm 18"	58	Up	X	

\*Designed to produce maximum breakout force, the Universal Rotor 406 mm (16") performs well in severe asphalt cuts.

\*\*The Universal Rotor 457 mm (18") is designed to provide maximum mixing depth and has lower breakout force compared to the Universal Rotor 406 mm (16").

**Rotor Options:**

*Some rotor options are not available in certain markets.*

- **Soil Rotor** is designed primarily for use in soil stabilization.
- **Combination Rotor** is designed primarily for use in soil stabilization with a secondary application in light cuts of asphalt reclamation.
- **Universal Rotor** can be used for either reclamation or stabilization.
- **Spade Rotor** is designed for soil stabilization applications.

**PRODUCTION ESTIMATING**

The maximum cutting depth is 381 mm (15 in) for the RM300 and 457 mm (18 in) for the RM500B. The RM300 can mix up to 457 mm (18 in). In addition, the cutting width of their rotors is 2.4 m (8 ft). The following formulas allow you to determine the production in square yards (yd<sup>2</sup>)/minute or cubic yards (yd<sup>3</sup>)/minute.

Production in square yards (yd<sup>2</sup>) per minute

$$\text{yd}^2/\text{min} = \frac{\text{FPM of travel speed}}{1.125}$$

$$\frac{9 \text{ ft}^2/\text{yd}^2}{8 \text{ ft Cutting width}} = 1.125 \text{ (This is a constant value for an eight foot wide rotor)}$$

Gallons of additive (for units with pump and metering additive system)

$$\frac{\text{GPM}}{\text{yd}^2/\text{min}} = \text{gal}/\text{yd}^2$$

Or, if required additive amounts are known, you can determine necessary travel speed as shown:

$$\frac{\text{GPM}}{\text{gal}/\text{yd}^2} = \text{yd}^2/\text{min}; \text{yd}^2/\text{min} \times 1.125 = \text{ft}/\text{min}$$

Production in Cubic Yards (yd<sup>3</sup>) per minute

$$\frac{\text{FPM of travel speed}}{1.125} \times \frac{\text{Cutting or mixing depth in inches}}{36} = \frac{\text{yd}^3}{\text{min}}$$

Production in Tons per Minute

$$\text{yd}^3/\text{min} \times \frac{\text{Wt. of Material per yd in lbs}}{2000 \text{ lb}/\text{ton}} = \text{tons}/\text{min}$$

**Abbreviations**

FPM = Feet Per Minute

GPM = Gallons Per Minute

**WEIGHT OF MATERIALS**

Material	LOOSE		IN-PLACE		
	kg/m <sup>3</sup>	lb/yd <sup>3</sup>	kg/m <sup>3</sup>	lb/yd <sup>3</sup>	
Clay	— Dry	1480	2500	1840	3100
	— Wet	1660	2800	2080	3500
Clay and Gravel	— Dry	1420	2400	1660	2800
	— Wet	1540	2600	1840	3100
Sand and Gravel	— Dry	1720	2900	1930	3250
	— Wet	2020	3400	2220	3750
Sand	— Dry	1420	2400	1600	2700
	— Damp	1690	2850	1900	3200
	— Wet	1840	3100	2080	3500
Earth	— Dry Packed	1510	2550	1900	3200
	— Wet Excavated	1600	2700	2020	3400
	— Top Soil	950	1600	1360	2300
	— Loam	1250	2100	1540	2600
Bituminous Concrete	— Windrowed Chunks (25% Voids)	1740	2925	—	—
	— Compacted	—	—	2310	3900

**STABILIZATION/RECLAMATION PRODUCTION**

The following charts list production in square meters per minute, square yards per minute, cubic meters per minute, and cubic yards per minute. The information is based on various travel speeds and cutting depths for Cat Rotary Mixers equipped with a 2438 mm (8 ft) cutting rotor.

		PRODUCTION RATES																
Travel Speed m/ min	m <sup>2</sup> /min	m <sup>3</sup> /minute																
		Cutting Depth — mm																
		100	125	150	175	200	225	250	275	300	325	350	375	400	425	450	475	500
3	7.3	0.73	0.9	1.1	1.3	1.5	1.6	1.8	2.0	2.2	2.4	2.6	2.7	2.9	3.1	3.3	3.5	3.7
6	14.6	1.46	1.8	2.2	2.6	2.9	3.3	3.7	4.0	4.4	4.8	5.1	5.5	5.9	6.2	6.6	6.9	7.3
9	21.9	2.2	2.7	3.3	3.8	4.4	4.9	5.5	6.0	6.6	7.1	7.7	8.2	8.8	9.3	9.9	10.4	11.0
12	29.3	2.9	3.7	4.4	5.1	5.9	6.6	7.3	8.0	8.8	9.5	10.2	11.0	11.7	12.4	13.2	13.9	14.6
15	36.6	3.6	4.6	5.5	6.4	7.3	8.2	9.1	10.0	11.0	11.9	12.8	13.7	14.6	15.5	16.5	17.4	18.3
18	43.9	4.4	5.5	6.6	7.7	8.8	9.9	11.0	12.1	13.2	14.3	15.4	16.5	17.6	18.7	19.7	20.8	21.9
21	51.2	5.1	6.4	7.7	9.0	10.2	11.5	12.8	14.1	15.4	16.6	17.9	19.2	20.5	21.8	23.0	24.3	25.6
24	58.5	5.9	7.3	8.8	10.2	11.7	13.2	14.6	16.1	17.6	19.0	20.5	21.9	23.4	24.9	26.3	27.8	29.3
27	65.8	6.6	8.2	9.9	11.5	13.2	14.8	16.4	18.1	19.7	21.4	23.0	24.7	26.3	28.0	29.6	31.3	32.9

		PRODUCTION RATES																
Travel Speed ft/ min	yd <sup>2</sup> /min	yd <sup>3</sup> /minute																
		Cutting Depth — inches																
		4	5	6	7	8	9	10	11	12	13	14	15	16	17	18	19	20
10	8.9	0.98	1.2	1.5	1.7	2.0	2.2	2.5	2.7	3.0	3.2	3.5	3.7	4.0	4.2	4.5	4.7	4.9
20	17.8	1.96	2.5	3.0	3.4	4.0	4.4	4.9	5.5	5.9	6.4	6.9	7.4	7.9	8.4	8.9	9.4	9.9
30	26.7	2.9	3.7	4.5	5.2	5.9	6.7	7.4	8.2	8.9	9.6	10.4	11.1	11.9	12.6	13.4	14.0	14.8
40	35.6	3.9	4.9	5.9	6.9	7.9	8.9	9.9	10.9	11.9	12.8	13.9	14.8	15.8	16.8	17.8	18.7	19.8
50	44.5	4.9	6.2	7.4	8.6	9.9	11.1	12.4	13.6	14.8	16.0	17.3	18.5	19.8	21.0	22.3	23.4	24.7
60	53.4	5.9	7.4	8.9	10.3	11.9	13.3	14.8	16.4	17.8	19.2	20.8	22.2	23.7	25.2	26.7	28.1	29.7
70	62.3	6.8	8.6	10.4	12.0	13.8	15.6	17.3	19.1	20.8	22.4	24.3	25.9	27.7	29.5	31.2	32.8	34.6
80	71.2	7.8	9.9	11.9	13.7	15.8	17.8	19.8	21.8	23.7	25.6	27.7	29.6	31.6	33.7	35.6	37.5	39.6
90	80.1	8.8	11.1	13.4	15.5	17.8	20.0	22.4	24.5	26.7	28.8	31.2	33.3	35.6	37.9	40.1	42.1	44.5

**Asphalt Pavers****Sustainability:**

- Long-lasting lubricants and fluids extend maintenance intervals, decreasing the amount of waste and filters contributed to environment.
- Ecology drains provide a simple means to drain machine fluids with a minimized risk of spillage.
- Maintenance free Cat batteries are recyclable.
- Cat ACERT engines meet applicable emission standards.
- Proprietary undercarriage design on Mobil-Trac™ pavers significantly reduces track belt wear, reducing frequency of replacement.
- Cat electric-heated screeds provide a reduction in engine emissions, which not only reduces the impact to the environment, but helps prevent soot build-up on indicators and decals — for enhanced safety.
- Electric-heated screeds produce less noise, which is appreciated by the crew as well as those who work and live near the construction sites.
- Electric-heated screeds, unlike their diesel counterparts, don't require a constant flame — another way emissions are reduced, and operators spared some heat.
- Electric-heated screeds are lighter, which means the paver consumes less fuel.
- Electric-heated screeds warm up quickly, another energy saver.
- Pavers equipped with Eco-mode can reduce engine speed to increase fuel efficiency during normal operation conditions.
- Pavers equipped with automatic engine speed control can be programmed to idle the engine when machine is in neutral for a predetermined amount of time, reducing fuel burn.

**Features:**

- **Variable width screeds** available.
- **Self-dumping hydraulic hoppers** are heavy-duty and high capacity.
- **Soldered and molded** electrical connections.
- **Self diagnostics** on propel and feeder systems.
- **Electrically heated screeds.**
- **Dual independent operating stations.**
- **Mobil-Trac undercarriage** provides speed of a wheeled paver with maneuverability of a track paver.
- **Optional Cat Grade and Slope** is integrated with the paver.
- **Large generators** deliver fast heat with less fuel consumption.\*
- **One-touch functions** for cleanout/warm up mode.\*
- **One-touch Auto-fill function.**\*
- **One-touch feeder system activation.**\*
- **Advanced generator diagnostics** helps determine heating element life.\*

\*Feature available on F Series pavers only.



MODEL	AP300F		AP500F		AP500F	
Gross Power	55.5 kW	<b>74.8 hp</b>	106 kW	<b>142 hp</b>	106 kW	<b>142 hp</b>
Rated Engine RPM	<b>2200</b>		<b>2200</b>		<b>2200</b>	
No. Cylinders	<b>4</b>		<b>4</b>		<b>4</b>	
Displacement	3.3 L	<b>201.4 in³</b>	4.4 L	<b>269 in³</b>	4.4 L	<b>269 in³</b>
Engine Model	<b>C3.3B</b>		<b>C4.4 ACERT</b>		<b>C4.4 ACERT</b>	
Emission Standards	<b>Tier 4 Final/Stage IV</b>		<b>Tier 3/Stage IIIA equivalent</b>		<b>Tier 4 Final/Stage IV</b>	
Operating Weight (Tractor)	6600 kg	<b>14,550 lb</b>	13 161 kg	<b>29,020 lb</b>	13 161 kg	<b>29,020 lb</b>
Speeds:						
Paving (Vibratory Screenshot)	61 m/min	<b>200 ft/min</b>	61 m/min	<b>200 ft/min</b>	61 m/min	<b>200 ft/min</b>
Paving (Tamper Bar Screenshot)	25 m/min	<b>82 ft/min</b>	25 m/min	<b>82 ft/min</b>	25 m/min	<b>82 ft/min</b>
Travel	16 km/h	<b>10 mph</b>	16 km/h	<b>10 mph</b>	16 km/h	<b>10 mph</b>
Tires:						
Front (4)	<b>455 × 260 Solid Rubber</b>		<b>13 × 22 Solid Rubber</b>		<b>13 × 22 Solid Rubber</b>	
Rear (2)	<b>365/80 R20</b>		<b>17.5 R25</b>		<b>17.5 R25</b>	
Dimensions:						
Standard Paving Width	1.75 m	<b>5'9"</b>	2.55 m	<b>8'4"</b>	2.55 m	<b>8'4"</b>
Shipping Width (maximum)	1.94 m	<b>6'4"</b>	2.76 m	<b>9'1"</b>	2.76 m	<b>9'1"</b>
Height (less exhaust)	2.65 m	<b>8'8"</b>	3.05 m	<b>10'0"</b>	3.05 m	<b>10'0"</b>
Approximate Length (with push roller and screed)	5.05 m	<b>16'6"</b>	6.29 m	<b>20'7"</b>	6.29 m	<b>20'7"</b>
Turning Radius	0.5 m	<b>1'8"</b>	0.35 m	<b>1'2"</b>	0.35 m	<b>1'2"</b>
Wheelbase	1950 mm	<b>6'5"</b>	2294 mm	<b>7'6"</b>	2294 mm	<b>7'6"</b>
Hopper Capacity	3.8 m³	<b>134 ft³</b>	6.7 m³	<b>237 ft³</b>	6.7 m³	<b>237 ft³</b>
Auger Diameter	260 mm	<b>10"</b>	406 mm	<b>16"</b>	406 mm	<b>16"</b>
Available Screenshot:						
SE34 V		<b>X</b>		—		—
SE34 VT		<b>X</b>		—		—
SE50 V		—		<b>X</b>		<b>X</b>
SE50 VT		—		<b>X</b>		<b>X</b>
SE60 V		—		—		—
SE60 V XW		—		—		—
SE60 VT XW		—		—		—
Service Refill Capacities:						
Cooling System	9 L	<b>2.4 U.S.gal</b>	30 L	<b>7.9 U.S. gal</b>	30 L	<b>7.9 U.S. gal</b>
Fuel Tank	110 L	<b>29 U.S.gal</b>	179 L	<b>47 U.S. gal</b>	179 L	<b>47 U.S. gal</b>
Diesel Exhaust Fluid Refill Capacity		—		—	19.1 L	<b>5 U.S. gal</b>
Hydraulic Oil Tank	80 L	<b>17.6 U.S.gal</b>	107 L	<b>28 U.S. gal</b>	107 L	<b>28 U.S. gal</b>

MODEL	AP600F		AP600F		AP1000F	
Gross Power	151 kW	202 hp	129 kW	175 hp	168 kW	225 hp
Rated Engine RPM	2200		2200		2200	
No. Cylinders	6		4		6	
Displacement	7.1 L	427.7 in <sup>3</sup>	4.4 L	268.5 in <sup>3</sup>	7.1 L	427.7 in <sup>3</sup>
Engine Model	C7.1 ACERT		C4.4 ACERT		C7.1 ACERT	
Emission Standards	Tier 3/Stage IIIA equivalent		Tier 4 Final/Stage IV		Tier 4 Final/Stage IV	
Operating Weight (Tractor)	13 845 kg	30,522 lb	13 845 kg	30,522 lb	15 889 kg	35,030 lb
Speeds:						
Paving (Vibratory Screed)	76 m/min	250 ft/min	76 m/min	250 ft/min	76 m/min	250 ft/min
Paving (Tamper Bar Screed)	25 m/min	82 ft/min	25 m/min	82 ft/min	25 m/min	82 ft/min
Travel	0-16 km/h	0-10 mph	0-16 km/h	0-10 mph	0-19.9 km/h	0-12 mph
Tires:						
Front (4)	13 × 22 Solid Rubber		13 × 22 Solid Rubber		16 × 22 Solid Rubber	
Rear (2)	16 × 25		16 × 25		18.00 R25	
Dimensions:						
Standard Paving Width	2550 mm	8'4"	2550 mm	8'4"	3200 mm	10'6"
Shipping Width (maximum)	3211 mm	10'6"	3211 mm	10'6"	3211 mm	10'6"
Height (less exhaust)	2997 mm	9'10"	2997 mm	9'10"	2929 mm	9'7"
Approximate Length (with push roller and screed)	6825 mm	22'5"	6825 mm	22'5"	7034 mm	23'1"
Turning Radius	1500 mm	4'6"	1500 mm	4'6"	500 mm	1'6"
Wheelbase	2776 mm	9'1"	2776 mm	9'1"	2776 mm	9'1"
Hopper Capacity	7.1 m <sup>3</sup>	250 ft <sup>3</sup>	7.1 m <sup>3</sup>	250 ft <sup>3</sup>	8.1 m <sup>3</sup>	286 ft <sup>3</sup>
Auger Diameter	406 mm	16"	406 mm	16"	406 mm	16"
Available Screeds:						
SE34 V		—		—		—
SE34 VT		—		—		—
SE50 V		X		X		—
SE50 VT		X		X		—
SE60 V		X		X		X
SE60 V XW		—		—		X
SE60 VT XW		—		—		X
Service Refill Capacities:						
Cooling System	37 L	9.8 U.S. gal	31 L	8 U.S. gal	45.4 L	12 U.S. gal
Fuel Tank	278 L	73 U.S. gal	278 L	73 U.S. gal	348 L	92 U.S. gal
Diesel Exhaust Fluid Refill Capacity		—	19.1 L	5 U.S. gal	37.8 L	10 U.S. gal
Hydraulic Oil Tank	219 L	58 U.S. gal	219 L	58 U.S. gal	219 L	58 U.S. gal

MODEL	AP255E		AP355F		AP555F		AP555F	
Gross Power	34.1 kW	<b>45.7 hp</b>	55 kW	<b>73.8 hp</b>	106 kW	<b>142 hp</b>	106 kW	<b>144 hp</b>
Rated Engine RPM	<b>2400</b>		<b>2200</b>		<b>2200</b>		<b>2200</b>	
No. Cylinders	<b>4</b>		<b>4</b>		<b>4</b>		<b>4</b>	
Displacement	2.2 L	<b>134.3 in<sup>3</sup></b>	3.3 L	<b>201.4 in<sup>3</sup></b>	4.4 L	<b>269 in<sup>3</sup></b>	4.4 L	<b>269 in<sup>3</sup></b>
Engine Model	<b>C2.2</b>		<b>C3.3B</b>		<b>C4.4 ACERT</b>		<b>C4.4 ACERT</b>	
Emission Standards	<b>Tier 4 Interim/ Stage IIIB equivalent</b>		<b>Tier 4 Final/ Stage IV</b>		<b>Tier 3/ Stage IIIA equivalent</b>		<b>Tier 4 Final/ Stage IV</b>	
Operating Weight (Tractor):								
with Mobil-Trac	—		7300 kg	<b>16,094 lb</b>	13 800 kg	<b>30,430 lb</b>	13 800 kg	<b>30,430 lb</b>
with Steel Track	4500 kg	<b>9921 lb</b>	—		—		—	
Maximum Speeds:								
Paving (Mobil-Trac)	—		64 m/min	<b>210 ft/min</b>	64 m/min	<b>210 ft/min</b>	64 m/min	<b>210 ft/min</b>
(Steel Track)	33 m/min	<b>108.3 ft/min</b>	—		—		—	
Travel (Mobil-Trac)	—		11 km/h	<b>7 mph</b>	11 km/h	<b>7 mph</b>	11 km/h	<b>7 mph</b>
(Steel Track)	16 km/h	<b>9.9 mph</b>	—		—		—	
Tracks Assemblies:								
Width (Mobil-Trac)	—		356 mm	<b>14"</b>	406 mm	<b>16"</b>	406 mm	<b>16"</b>
(Steel Track)	200 mm	<b>7.9"</b>	—		—		—	
Length on Ground:								
(Mobil-Trac)	—		2615 mm	<b>8'7"</b>	2460 mm	<b>8'1"</b>	2460 mm	<b>8'1"</b>
(Steel Track)	1420 mm	<b>4'8"</b>	—		—		—	
Dimensions:								
Standard Paving Width	1.4 m	<b>4'7"</b>	1.75 m	<b>5'9"</b>	2.55 m	<b>8'4"</b>	2.55 m	<b>8'4"</b>
Shipping Width (maximum)	1.6 m	<b>5'3"</b>	1.94 m	<b>6'4"</b>	2.76 m	<b>9'1"</b>	2.76 m	<b>9'1"</b>
Height (less exhaust)	1.8 m	<b>5'11"</b>	2.65 m	<b>8'8"</b>	3.06	<b>10'0"</b>	3.06	<b>10'0"</b>
Length (screed, push roller)	4.04 m	<b>13'3"</b>	5.05 m	<b>16'6"</b>	6.32 m	<b>20'9"</b>	6.32 m	<b>20'9"</b>
Turning Radius	0.7 m	<b>2'4"</b>	0.5 m	<b>1'8"</b>	304 mm	<b>12"</b>	304 mm	<b>12"</b>
Hopper Capacity	3.1 m <sup>3</sup>	<b>109.5 ft<sup>3</sup></b>	3.8 m <sup>3</sup>	<b>134 ft<sup>3</sup></b>	6.2 m <sup>3</sup>	<b>219 ft<sup>3</sup></b>	6.2 m <sup>3</sup>	<b>219 ft<sup>3</sup></b>
Auger Diameter	260 mm	<b>10.2"</b>	260 mm	<b>10"</b>	406 mm	<b>16"</b>	406 mm	<b>16"</b>
Available Screens:								
AS3143	<b>X</b>		—		—		—	
SE34 V	—		<b>X</b>		—		—	
SE34 VT	—		<b>X</b>		—		—	
SE50 V	—		—		<b>X</b>		<b>X</b>	
SE50 VT	—		—		<b>X</b>		<b>X</b>	
SE60 V	—		—		—		—	
SE60 V XW	—		—		—		—	
SE60 VT XW	—		—		—		—	
Service Refill Capacities:								
Cooling System	17 L	<b>4.5 U.S.gal</b>	9 L	<b>2.4 U.S.gal</b>	30 L	<b>7.9 U.S. gal</b>	30 L	<b>7.9 U.S. gal</b>
Fuel Tank	65 L	<b>17.2 U.S.gal</b>	110 L	<b>29 U.S.gal</b>	189 L	<b>50 U.S. gal</b>	189 L	<b>50 U.S. gal</b>
Diesel Exhaust Fluid Refill Capacity	—		—		—		19.1 L	<b>5 U.S. gal</b>
Hydraulic Oil Tank	73 L	<b>19.3 U.S.gal</b>	80 L	<b>17.6 U.S.gal</b>	170 L	<b>45 U.S. gal</b>	170 L	<b>45 U.S. gal</b>

MODEL	AP655F		AP655F		AP1055F		AP1055F	
Gross Power	151 kW	<b>202 hp</b>	129 kW	<b>175 hp</b>	186 kW	<b>249 hp</b>	168 kW	<b>225 hp</b>
Rated Engine RPM	<b>2200</b>		<b>2200</b>		<b>2200</b>		<b>2200</b>	
No. Cylinders	<b>6</b>		<b>4</b>		<b>6</b>		<b>6</b>	
Displacement	7.1 L	<b>427.7 in<sup>3</sup></b>	4.4 L	<b>268.5 in<sup>3</sup></b>	7.1 L	<b>427.7 in<sup>3</sup></b>	7.1 L	<b>427.7 in<sup>3</sup></b>
Engine Model	<b>C7.1</b>		<b>C4.4 ACERT</b>		<b>C7.1</b>		<b>C7.1 ACERT</b>	
Emission Standards	<b>Tier 3/ Stage IIIA equivalent</b>		<b>Tier 4 Final/ Stage IV</b>		<b>Tier 3/ Stage IIIA equivalent</b>		<b>Tier 4 Final/ Stage IV</b>	
Operating Weight (Tractor):								
with Mobil-Trac	15 584 kg	<b>34,356 lb</b>	15 584 kg	<b>34,356 lb</b>	17 056 kg	<b>37,608 lb</b>	17 056 kg	<b>37,608 lb</b>
with Steel Track	16 043 kg	<b>35,368 lb</b>	16 043 kg	<b>35,368 lb</b>	—	—	—	—
Maximum Speeds:								
Paving (Mobil-Trac)	64 m/min	<b>210 ft/min</b>	64 m/min	<b>210 ft/min</b>	64 m/min	<b>210 ft/min</b>	64 m/min	<b>210 ft/min</b>
(Steel Track)	49 m/min	<b>160 ft/min</b>	49 m/min	<b>160 ft/min</b>	—	—	—	—
Travel (Mobil-Trac)	14.5 km/h	<b>9 mph</b>	14.5 km/h	<b>9 mph</b>	14.5 km/h	<b>9 mph</b>	14.5 km/h	<b>9 mph</b>
(Steel Track)	6.5 km/h	<b>4 mph</b>	6.5 km/h	<b>4 mph</b>	—	—	—	—
Tracks Assemblies:								
Width (Mobil-Trac)	406 mm	<b>16"</b>	406 mm	<b>16"</b>	457 mm	<b>18"</b>	457 mm	<b>18"</b>
(Steel Track)	356 mm	<b>14"</b>	356 mm	<b>14"</b>	—	—	—	—
Length on Ground:								
(Mobil-Trac)	3020 mm	<b>9'11"</b>	3020 mm	<b>9'11"</b>	3136 mm	<b>10'3"</b>	3136 mm	<b>10'3"</b>
(Steel Track)	3048 mm	<b>10'0"</b>	3048 mm	<b>10'0"</b>	—	—	—	—
Dimensions:								
Standard Paving Width	2550 mm	<b>8'4"</b>	2550 mm	<b>8'4"</b>	3200 mm	<b>10'6"</b>	3200 mm	<b>10'6"</b>
Shipping Width (maximum)	3211 mm	<b>10'6"</b>	3211 mm	<b>10'6"</b>	3211 mm	<b>10'6"</b>	3211 mm	<b>10'6"</b>
Height (less exhaust)	2997 mm	<b>9'10"</b>	2997 mm	<b>9'10"</b>	2929 mm	<b>9'7"</b>	2929 mm	<b>9'7"</b>
Length (screed, push roller)	6910 mm	<b>22'8"</b>	6910 mm	<b>22'8"</b>	7034 mm	<b>23'1"</b>	7034 mm	<b>23'1"</b>
Turning Radius	304 mm	<b>12"</b>	304 mm	<b>12"</b>	0 mm	<b>0"</b>	0 mm	<b>0"</b>
Hopper Capacity	7.1 m <sup>3</sup>	<b>250 ft<sup>3</sup></b>	7.1 m <sup>3</sup>	<b>250 ft<sup>3</sup></b>	8.1 m <sup>3</sup>	<b>286 ft<sup>3</sup></b>	8.1 m <sup>3</sup>	<b>286 ft<sup>3</sup></b>
Auger Diameter	406 mm	<b>16"</b>	406 mm	<b>16"</b>	406 mm	<b>16"</b>	406 mm	<b>16"</b>
Available Screens:								
AS3143	—	—	—	—	—	—	—	—
SE34 V	—	—	—	—	—	—	—	—
SE34 VT	—	—	—	—	—	—	—	—
SE50 V	X	X	X	X	—	—	—	—
SE50 VT	X	X	X	X	—	—	—	—
SE60 V	X	X	X	X	X	X	X	X
SE60 V XW	X	X	X	X	X	X	X	X
SE60 VT XW	X	X	X	X	X	X	X	X
Service Refill Capacities:								
Cooling System	37 L	<b>9.8 U.S. gal</b>	31 L	<b>8 U.S. gal</b>	45.4 L	<b>12 U.S. gal</b>	45.4 L	<b>12 U.S. gal</b>
Fuel Tank	278 L	<b>73 U.S. gal</b>	278 L	<b>73 U.S. gal</b>	348 L	<b>92 U.S. gal</b>	348 L	<b>92 U.S. gal</b>
Diesel Exhaust Fluid Refill Capacity	—	—	19.1 L	<b>5 U.S. gal</b>	—	—	19.1 L	<b>5 U.S. gal</b>
Hydraulic Oil Tank	219 L	<b>58 U.S. gal</b>	219 L	<b>58 U.S. gal</b>	219 L	<b>58 U.S. gal</b>	219 L	<b>58 U.S. gal</b>

MODEL	AS3143		SE34 V		SE34 VT	
Standard Paving Width	1.40 m	<b>4'7"</b>	1.75 m	<b>5'9"</b>	1.75 m	<b>5'9"</b>
Paving Ranges:						
Hydraulically Extendible (maximum)	2.60 m	<b>8'6"</b>	3.42 m	<b>11'2"</b>	3.42 m	<b>11'2"</b>
With Bolt-on Extensions (maximum)	3.40 m	<b>11'2"</b>	4.57 m	<b>15'1"</b>	4.00 m	<b>13'1"</b>
With Cutoff Shoes (minimum)	0.15 m	<b>6"</b>	0.70 m	<b>2'4"</b>	0.70 m	<b>2'4"</b>
Extender Mounting		<b>Rear</b>		<b>Rear</b>		<b>Rear</b>
Tamper System		—		—		<b>X</b>
Vibration System		<b>X</b>		<b>X</b>		—
Length:						
Without End Gates (front to rear)		—		—		—
With End Gates (front to rear)		—		—		—
Width:						
Without End Gates		—		—		—
With End Gates		—		—		—
Height	0.94 m	<b>3'1"</b>		—		—
Weights:						
Electric Heat Screed	700 kg	<b>1563 lb</b>	1400 kg	<b>3086 lb</b>	1450 kg	<b>3196 lb</b>

MODEL	SE50 V		SE50 VT		SE60 V	
Standard Paving Width	2.55 m	<b>8'4"</b>	2.55 m	<b>8'4"</b>	3.00 m	<b>9'10"</b>
Paving Ranges:						
Hydraulically Extendible (maximum)	5.00 m	<b>16'4"</b>	5.00 m	<b>16'4"</b>	6.00 m	<b>19'6"</b>
With Bolt-on Extensions (maximum)	6.50 m	<b>21'4"</b>	8.00 m	<b>26'4"</b>	7.65 m	<b>25'0"</b>
With Cutoff Shoes (minimum)		—		—		—
Extender Mounting		<b>Rear</b>		<b>Rear</b>		<b>Rear</b>
Tamper System		—		<b>X</b>		—
Vibration System		<b>X</b>		—		<b>X</b>
Length:						
Without End Gates (front to rear)		—		—		—
With End Gates (front to rear)		—		—		—
Width:						
Without End Gates	2.55 m	<b>8'4"</b>	2.55 m	<b>8'4"</b>	3.21 m	<b>10'6"</b>
With End Gates	2.76 m	<b>9'1"</b>	2.76 m	<b>9'1"</b>	3.21 m	<b>10'6"</b>
Height		—		—	2.30 mm	<b>7'7"</b>
Weights:						
Electric Heat Screed	3284 kg	<b>7239 lb</b>	3340 kg	<b>7363 lb</b>	3400 kg	<b>7495 lb</b>

<b>MODEL</b>	<b>SE60 V XW</b>		<b>SE60 VT XW</b>	
Standard Paving Width	3.00 m	<b>9'10"</b>	3.00 m	<b>9'10"</b>
Paving Ranges:				
Hydraulically Extendible (maximum)	6.00 m	<b>19'6"</b>	6.00 m	<b>19'6"</b>
With Bolt-on Extensions (maximum)	10.00 m	<b>33'0"</b>	10.00 m	<b>33'0"</b>
With Cutoff Shoes (minimum)	—		—	
Extender Mounting	<b>Rear</b>		<b>Rear</b>	
Tamper System	—		<b>X</b>	
Vibration System	<b>X</b>		—	
Length:				
Without End Gates (front to rear)	1.78 m	<b>5'10"</b>	1.78 m	<b>5'10"</b>
With End Gates (front to rear)	2.50 m	<b>8'3"</b>	2.50 m	<b>8'3"</b>
Width:				
Without End Gates	3.21 m	<b>10'6"</b>	3.21 m	<b>10'6"</b>
With End Gates	3.21 m	<b>10'6"</b>	3.21 m	<b>10'6"</b>
Height	2.30 mm	<b>7'7"</b>	2.30 mm	<b>7'7"</b>
Weights:				
Electric Heat Screed	4070 kg	<b>8973 lb</b>	4490 kg	<b>7695 lb</b>

**ASPHALT PAVING CHARTS**

These charts will assist you when trying to match plant output with paving speeds. Keep in mind when using these charts, it will be at 100% efficiency. If you know efficiency, multiply T.P. hour × efficiency. (Example: 75% efficiency at 300 T.P.H. –  $300 \times 0.75 = 225$  T.P.H.)

**Production in tons/hr with 1" compacted mat**

Speed	Paving Widths						
ft/min	6'0"	7'0"	8'0"	9'0"	10'0"	11'0"	12'0"
10	22	26	29	33	37	40	44
20	44	51	58	66	73	80	88
30	66	77	87	99	110	120	131
40	88	102	116	131	146	161	175
50	110	129	145	164	183	201	219

**Production in tons/hr with 2" compacted mat**

Speed	Paving Widths						
ft/min	6'0"	7'0"	8'0"	9'0"	10'0"	11'0"	12'0"
10	44	52	58	66	74	80	88
20	88	176	116	132	146	160	176
30	132	154	174	198	220	240	262
40	176	204	232	262	292	322	350
50	220	258	290	328	366	402	438

**Production in tons/hr with 3" compacted mat**

Speed	Paving Widths						
ft/min	6'0"	7'0"	8'0"	9'0"	10'0"	11'0"	12'0"
10	66	78	87	99	111	120	132
20	132	153	174	198	219	240	284
30	198	231	261	297	330	360	393
40	264	306	348	393	438	483	525
50	330	387	435	492	549	603	657

**Production in tons/hr with 4" compacted mat**

Speed	Paving Widths						
ft/min	6'0"	7'0"	8'0"	9'0"	10'0"	11'0"	12'0"
10	88	104	116	132	148	160	176
20	176	204	232	264	292	320	352
30	264	308	348	396	440	480	524
40	352	408	464	524	584	644	700
50	440	516	580	656	732	804	876

**Slope Conversion Table**

Percent	Inches per foot	Inches per 12 foot	Percent	Inches per foot	Inches per 12 foot
0.17%		1/4	5.21%	5/8	7 1/2
0.35%		1/2	5.38%		7 3/4
0.52%	1/16	3/4	5.56%		8
0.70%		1	5.73%	11/16	8 1/4
0.87%		1 1/4	5.90%		8 1/2
1.04%	1/8	1 1/2	6.08%		8 3/4
1.22%		1 3/4	6.25%	3/4	9
1.39%		2	6.42%		9 1/4
1.56%	3/16	2 1/4	6.60%		9 1/2
1.74%		2 1/2	6.77%	13/16	9 3/4
1.91%		2 3/4	6.94%		10
2.08%	1/4	3	7.12%		10 1/4
2.26%		3 1/4	7.29%	7/8	10 1/2
2.43%		3 1/2	7.47%		10 3/4
2.60%	5/16	3 3/4	7.64%		11
2.78%		4	7.81%	15/16	11 1/4
2.95%		4 1/4	7.99%		11 1/2
3.13%	3/8	4 1/2	8.16%		11 3/4
3.30%		4 3/4	8.33%	1	12
3.47%		5	8.51%		12 1/4
3.65%	7/16	5 1/4	8.68%		12 1/2
3.82%		5 1/2	8.85%	1 1/16	12 3/4
3.99%		5 3/4	9.03%		13
4.17%	1/2	6	9.20%		13 1/4
4.34%		6 1/4	9.38%	1 1/8	13 1/2
4.51%		6 1/2	9.55%		13 3/4
4.69%	9/16	6 3/4	9.72%		14
4.86%		7	9.90%	1 3/16	14 1/4
5.04%		7 1/4	10.07%		14 1/2

**Formula:**

$$\text{Percent} = \frac{\text{Inches per foot} \times 100}{12}$$

**Inches in decimals of a foot**

1/16 = .0052	1 = .0833
3/32 = .0078	2 = .1667
1/8 = .0104	3 = .2500
3/16 = .0156	4 = .3333
1/4 = .0208	5 = .4167
5/16 = .0260	6 = .5000
3/8 = .0313	7 = .5833
1/2 = .0417	8 = .6667
5/8 = .0521	9 = .7500
3/4 = .0625	10 = .8333
7/8 = .0729	11 = .9167



### **Vibratory and Pneumatic Tire Compactors**

#### **Sustainability:**

- Long-lasting lubricants and fluids extend maintenance intervals, decreasing the amount of waste and filters contributed to environment.
- Ecology drains provide a simple means to drain machine fluids with a minimized risk of spillage.
- Maintenance free Cat batteries are recyclable.
- Cat ACERT engines meet applicable emission standards.
- Biodegradable oil option available.

#### **General Compactor Features:**

- **Routine maintenance** simplified by grouped service points and easy access to service areas.
- **Operator stations** designed for maximum comfort, easy control, and optimal visibility.
- **Direct hydrostatic drive to front (drums or wheels) and rear (drums or wheels)** provides dependable, responsive, propulsion effort and maximum gradeability. (Does not include pneumatic tire compactors.)
- **Eco-mode standard equipment** on B Series Vibratory Soil Compactors and Double Drum Rollers reduces fuel consumption.

#### **Vibratory Compactor Features:**

##### **Single Drum**

- **Dual pump system** delivers positive tractive effort to both drum and rear wheels, regardless of underfooting. This increases the machine's ability to maneuver in a wide variety of soil types and conditions and improves gross gradeability.
- **Limited slip high traction differential** is standard on all units for best traction of rear tires.
- **Optional heavy-duty front-mounted blade** with reversible cutting edge is available to allow backfilling and leveling during compaction.
- **ROPS (Roll Over Protective Structure)** standard on all units. Enclosed cabs with EROPS rating available as an option.

- **Optional Cat Compaction Control** featuring exclusive Machine Drive Power (MDP) or CMV (accelerometer-based) measurement scalable to include GNSS mapping and recording.
- **Adjustable jaw-type cleaner bar** keeps drums clean between pads during forward and reverse movement.

##### **Double Drum and Combi**

- **Vibration automatically ceases before machine comes to a stop** to help produce a smooth, flawless mat surface.
- **Close side clearances** allow compactors to work close to curbs, walls and other obstructions.
- **Large, rust-proof water tanks and pressure spray system** provide hours of reliable operation between fill-ups.
- **Emulsion system** available for combi compactor rear tires to prevent materials sticking to tires.
- **ROPS (Roll Over Protective Structure)** available on all models. Enclosed cabs with EROPS rating available on some models.
- **Optional Cat Compaction Control** featuring GNSS mapping of pass count and mat surface temperature.

##### **Pneumatic Tire Compactor Features:**

- **All wheel oscillation.** Front and rear tires provide even wheel loads regardless of evenness underfoot.
- **High drive propel system.** Completely hydrostatic with drive motors and brakes located in mainframe away from contamination and damage.
- **Ballast compartments** are easily accessible for quick loading and are located to provide balanced wheel/weight ratio.
- **Single-lever hand control** of forward and reverse movement makes smooth rolling easy.
- **Optional Cat Compaction Control** featuring GNSS mapping of pass count and mat surface temperature.

**NOTE: All models and options are not available in all markets.**

MODEL	CS34		CS423E	
Gross Power	55 kW	74 hp	62 kW	83 hp
Rated Engine RPM	2200		2200	
No. Cylinders	4		4	
Displacement	3.4 L	207 in <sup>3</sup>	4.4 L	269 in <sup>3</sup>
Engine Model	C3.4B		3054C	
Emission Standards	Tier 4 Final/Stage IV		Tier 2/Stage II equivalent	
Speeds	1 forward/1 reverse		2 forward/2 reverse	
Max. Speed (For./Rev.)	8.9 km/h	5.5 mph	11.5 km/h	7.1 mph
Approximate Operating Weight	4445 kg	9799 lb	6745 kg	14,875 lb
Theoretical Gradeability <sup>1</sup>	—		—	
Rimpull <sup>2</sup>	—		—	
Drive	Drum/Rear Wheel		Drum/Rear Wheel	
Steering:				
Inside Radius	2625 mm	8'7"	3050 mm	10'0"
Outside Radius	3896 mm	12'9"	4730 mm	15'6"
Steering Angle	±38°		±37°	
Vibratory System:				
Ecc. Weight Drive	Hydraulic		Hydraulic	
Frequency	35 Hz	2100 vpm	31.9 Hz	1915 vpm
Amplitude:	1		2	
High Amplitude	1.3 mm	0.05"	1.67 mm	0.066"
Low Amplitude	1.3 mm	0.05"	0.84 mm	0.033"
Centrifugal Force:				
Maximum	66.8 kN	15,000 lb	133.5 kN	30,000 lb
Minimum	66.8 kN	15,000 lb	66.8 kN	15,000 lb
General Dimensions:				
Overall Width with Blade	—		—	
Overall Width without Blade	1393 mm	4'6"	1800 mm	5'11"
Drum Width	1270 mm	4'2"	1680 mm	5'6"
Drum Diameter	1016 mm	3'4"	1220 mm	4'0"
Tires	11.2 × 24 — 6 ply		14.9 × 24 — 6 ply	
Overall Height	2514 mm	8'2"	2930 mm	9'7"
Wheel to Drum	2240 mm	7'4"	2600 mm	8'6"
Overall Length	4150 mm	13'7"	4960 mm	16'3"
Curb Clearance	335 mm	13.2"	375 mm	14.8"
Service Refill Capacities:				
Fuel Tank	113 L	30 U.S. gal	153 L	40.4 U.S. gal
Crankcase	8 L	2.1 U.S. gal	6.8 L	1.8 U.S. gal
Hydraulic Fluid	40 L	10.6 U.S. gal	60 L	16 U.S. gal

<sup>1</sup>Theoretical gradeability calculated using rimpull, machine weight, weight transfer and slippage. Actual gradeability may vary based on site conditions and machine configuration.

<sup>2</sup>Actual performance may vary due to site conditions.

MODEL	CS44B		CS533E		CS54B <sup>3</sup>	
Gross Power	75 kW	<b>100.6 hp</b>	97 kW	<b>130 hp</b>	98 kW	<b>131 hp</b>
Rated Engine RPM	<b>2200</b>		<b>2200</b>		<b>2200</b>	
No. Cylinders	<b>4</b>		<b>4</b>		<b>4</b>	
Displacement	3.4 L	<b>207 in<sup>3</sup></b>	4.4 L	<b>269 in<sup>3</sup></b>	4.4 L	<b>268 in<sup>3</sup></b>
Engine Model	<b>C3.4B</b>		<b>C4.4 ACERT</b>		<b>C4.4 ACERT</b>	
Emission Standards	<b>Tier 4 Final/Stage IV</b>		<b>Tier 2/Stage II equivalent</b>		<b>Tier 4 Final/Stage IV</b>	
Speeds	<b>2 forward/2 reverse</b>		<b>2 forward/2 reverse</b>		<b>2 forward/2 reverse</b>	
Max. Speed (For./Rev.)	12.3 km/h	<b>7.6 mph</b>	12 km/h	<b>7.5 mph</b>	11.1 km/h	<b>6.8 mph</b>
Approximate Operating Weight	6943 kg	<b>15,307 lb</b>	10 485 kg	<b>23,120 lb</b>	10 555 kg	<b>23,265 lb</b>
Theoretical Gradeability <sup>1</sup>	<b>60%</b>		—		<b>55%</b>	
Rimpull <sup>2</sup>	54 kN	<b>12,140 lbf</b>	—		55 kN	<b>12,365 lbf</b>
Drive	<b>Drum/Rear Wheel</b>		<b>Drum/Rear Wheel</b>		<b>Drum/Rear Wheel</b>	
Steering:						
Inside Radius	3050 mm	<b>10'0"</b>	3680 mm	<b>12'1"</b>	3680 mm	<b>12'1"</b>
Outside Radius	4730 mm	<b>15'6"</b>	5810 mm	<b>19'1"</b>	5810 mm	<b>19'1"</b>
Steering Angle	<b>±37°</b>		<b>±34°</b>		<b>±34°</b>	
Vibratory System:						
Ecc. Weight Drive	<b>Hydraulic</b>		<b>Hydraulic</b>		<b>Hydraulic</b>	
Frequency	31.9 Hz	<b>1914 vpm</b>	31 Hz	<b>1860 vpm</b>	30.5 Hz	<b>1830 vpm</b>
Amplitude:	<b>2</b>		<b>2</b>		<b>2</b>	
High Amplitude	1.59 mm	<b>0.063"</b>	1.80 mm	<b>0.071"</b>	1.90 mm	<b>0.075"</b>
Low Amplitude	0.80 mm	<b>0.032"</b>	0.85 mm	<b>0.033"</b>	0.95 mm	<b>0.037"</b>
Centrifugal Force:						
Maximum	133 kN	<b>29,900 lb</b>	234 kN	<b>52,600 lb</b>	234 kN	<b>52,600 lb</b>
Minimum	67 kN	<b>15,000 lb</b>	133 kN	<b>30,000 lb</b>	133 kN	<b>29,900 lb</b>
General Dimensions:						
Overall Width with Blade	2120 mm	<b>7'0"</b>	—		—	
Overall Width without Blade	1800 mm	<b>5'11"</b>	2286 mm	<b>7'6"</b>	2300 mm	<b>7'7"</b>
Drum Width	1676 mm	<b>5'6"</b>	2130 mm	<b>7'0"</b>	2134 mm	<b>7'0"</b>
Drum Diameter	1221 mm	<b>4'0"</b>	1534 mm	<b>5'0"</b>	1534 mm	<b>5'0"</b>
Tires	<b>14.9 × 24 — 6 ply</b>		<b>23.1 × 26 — 8 ply floatation</b>		<b>23.1 × 26 — 8 ply floatation</b>	
Overall Height	2850 mm	<b>9'4"</b>	3070 mm	<b>10'1"</b>	3110 mm	<b>10'3"</b>
Wheel to Drum	2600 mm	<b>8'6"</b>	2900 mm	<b>9'6"</b>	2900 mm	<b>9'7"</b>
Overall Length	5090 mm	<b>16'9"</b>	5510 mm	<b>18'1"</b>	5850 mm	<b>19'2"</b>
Curb Clearance	369 mm	<b>14.5"</b>	521 mm	<b>20.5"</b>	543 mm	<b>21.4"</b>
Service Refill Capacities:						
Fuel Tank	150 L	<b>39.6 U.S. gal</b>	180 L	<b>47.5 U.S. gal</b>	242 L	<b>64 U.S. gal</b>
Diesel Exhaust Fluid Refill Capacity	18.9 L	<b>5 U.S. gal</b>	—		15 L	<b>4 U.S. gal</b>
Crankcase	9 L	<b>2.4 U.S. gal</b>	9 L	<b>2.4 U.S. gal</b>	8.8 L	<b>2.3 U.S. gal</b>
Hydraulic Fluid	26 L	<b>6.9 U.S. gal</b>	60 L	<b>16 U.S. gal</b>	50 L	<b>13.2 U.S. gal</b>

<sup>1</sup>Theoretical gradeability calculated using rimpull, machine weight, weight transfer and slippage. Actual gradeability may vary based on site conditions and machine configuration.

<sup>2</sup>Actual performance may vary due to site conditions.

<sup>3</sup>Some markets feature a Cat C4.4 ACERT engine that meets U.S. EPA Tier 3/EU Stage IIIA equivalent emission standards.

MODEL	CS56B <sup>3</sup>		CS64B <sup>3</sup>		CS66B	
Gross Power	117 kW	157 hp	98 kW	131 hp	117 kW	157 hp
Rated Engine RPM	2200		2200		2200	
No. Cylinders	4		4		4	
Displacement	4.4 L	268 in <sup>3</sup>	4.4 L	268 in <sup>3</sup>	4.4 L	268 in <sup>3</sup>
Engine Model	C4.4 ACERT		C4.4 ACERT		C4.4 ACERT	
Emission Standards	Tier 4 Final/Stage IV		Tier 4 Final/Stage IV		Tier 4 Final/Stage IV	
Speeds	2 forward/2 reverse		2 forward/2 reverse		2 forward/2 reverse	
Max. Speed (For./Rev.)	11.1 km/h	6.8 mph	11 km/h	6.8 mph	11.4 km/h	7 mph
Approximate Operating Weight	11 555 kg	25,474 lb	12 305 kg	27,128 lb	12 360 kg	27,245 lb
Theoretical Gradeability <sup>1</sup>	57%		50%		57%	
Rimpull <sup>2</sup>	95 kN	21,357 lbf	55 kN	12,365 lbf	95 kN	21,357 lbf
Drive	Drum/Rear Wheel		Drum/Rear Wheel		Drum/Rear Wheel	
Steering:						
Inside Radius	3680 mm	12'1"	3680 mm	12'1"	3680 mm	12'1"
Outside Radius	5810 mm	19'1"	5810 mm	19'1"	5810 mm	19'1"
Steering Angle	±34°		±34°		±34°	
Vibratory System:						
Ecc. Weight Drive	Hydraulic		Hydraulic		Hydraulic	
Frequency	30.5 Hz	1830 vpm	30.5 Hz	1830 vpm	30.5 Hz	1830 vpm
Amplitude:	2		2		2	
High Amplitude	2.10 mm	0.083"	1.90 mm	0.075"	2.10 mm	0.083"
Low Amplitude	0.98 mm	0.039"	0.95 mm	0.037"	0.98 mm	0.039"
Centrifugal Force:						
Maximum	301 kN	67,600 lb	234 kN	52,600 lb	301 kN	67,600 lb
Minimum	141 kN	31,670 lb	133 kN	29,900 lb	141 kN	31,670 lb
General Dimensions:						
Overall Width with Blade	2500 mm	8'3"	—	—	2500 mm	8'3"
Overall Width without Blade	2300 mm	7'7"	2330 mm	7'8"	2330 mm	7'8"
Drum Width	2134 mm	7'0"	2134 mm	7'0"	2134 mm	7'0"
Drum Diameter	1534 mm	5'0"	1534 mm	5'0"	1534 mm	5'0"
Tires	23.1 × 26 — 8 ply floatation		23.1 × 26 — 8 ply floatation		23.1 × 26 — 8 ply floatation	
Overall Height	3110 mm	10'3"	3110 mm	10'3"	3110 mm	10'3"
Wheel to Drum	2900 mm	9'7"	2900 mm	9'7"	2900 mm	9'7"
Overall Length	5860 mm	19'3"	5850 mm	19'2"	5860 mm	19'3"
Curb Clearance	494 mm	19.4"	543 mm	21.4"	494 mm	19.4"
Service Refill Capacities:						
Fuel Tank	242 L	64 U.S. gal	242 L	64 U.S. gal	242 L	64 U.S. gal
Diesel Exhaust Fluid Refill Capacity	15 L	4 U.S. gal	15 L	4 U.S. gal	15 L	4 U.S. gal
Crankcase	11.6 L	3.1 U.S. gal	8.8 L	2.3 U.S. gal	11.6 L	3.1 U.S. gal
Hydraulic Fluid	50 L	13.2 U.S. gal	50 L	13.2 U.S. gal	50 L	13.2 U.S. gal

<sup>1</sup>Theoretical gradeability calculated using rimpull, machine weight, weight transfer and slippage. Actual gradeability may vary based on site conditions and machine configuration.

<sup>2</sup>Actual performance may vary due to site conditions.

<sup>3</sup>Some markets feature a Cat C4.4 ACERT engine that meets U.S. EPA Tier 3/EU Stage IIIA equivalent emission standards.

MODEL	CS68B <sup>3</sup>		CS74B <sup>4</sup>		CS76B	
Gross Power	117 kW	157 hp	129.5 kW	173.7 hp	129.5 kW	173.7 hp
Rated Engine RPM	2200		2200		2200	
No. Cylinders	4		4		4	
Displacement	4.4 L	268 in <sup>3</sup>	4.4 L	268 in <sup>3</sup>	4.4 L	268 in <sup>3</sup>
Engine Model	C4.4 ACERT		C4.4 ACERT		C4.4 ACERT	
Emission Standards	Tier 4 Final/Stage IV		Tier 4 Final/Stage IV		Tier 4 Final/Stage IV	
Speeds	2 forward/2 reverse		2 forward/2 reverse		2 forward/2 reverse	
Max. Speed (For./Rev.)	11.4 km/h	7 mph	11.4 km/h	7 mph	11.4 km/h	7 mph
Approximate Operating Weight	14 325 kg	31,572 lb	16 000 kg	35,264 lb	17 445 kg	38,450 lb
Theoretical Gradeability <sup>1</sup>	57%		57%		57%	
Rimpull <sup>2</sup>	95 kN	21,357 lbf	96 kN	21,582 lbf	96 kN	21,582 lbf
Drive	Drum/Rear Wheel		Drum/Rear Wheel		Drum/Rear Wheel	
Steering:						
Inside Radius	3680 mm	12'1"	3680 mm	12'1"	3680 mm	12'1"
Outside Radius	5810 mm	19'1"	5810 mm	19'1"	5810 mm	19'1"
Steering Angle	±34°		±34°		±34°	
Vibratory System:						
Ecc. Weight Drive	Hydraulic		Hydraulic		Hydraulic	
Frequency	30.5 Hz	1830 vpm	30.5 Hz	1830 vpm	30.5 Hz	1830 vpm
Amplitude:	2		2		2	
High Amplitude	2.10 mm	0.083"	2.10 mm	0.083"	2.10 mm	0.083"
Low Amplitude	0.98 mm	0.039"	0.98 mm	0.039"	0.98 mm	0.039"
Centrifugal Force:						
Maximum	301 kN	67,600 lb	332 kN	74,600 lb	332 kN	74,600 lb
Minimum	141 kN	31,670 lb	166 kN	37,300 lb	166 kN	37,300 lb
General Dimensions:						
Overall Width with Blade	2500 mm	8'3"	2500 mm	8'3"	—	—
Overall Width without Blade	2330 mm	7'8"	2330 mm	7'8"	2360 mm	7'9"
Drum Width	2134 mm	7'0"	2134 mm	7'0"	2134 mm	7'0"
Drum Diameter	1534 mm	5'0"	1534 mm	5'0"	1534 mm	5'0"
Tires	23.1 × 26 — 8 ply floatation		23.1 × 26 — 8 ply floatation		23.1 × 26 — 12 ply floatation	
Overall Height	3110 mm	10'3"	3110 mm	10'3"	3110 mm	10'3"
Wheel to Drum	2900 mm	9'7"	2900 mm	9'7"	2900 mm	9'7"
Overall Length	6050 mm	19'10"	6050 mm	19'10"	6130 mm	20'1"
Curb Clearance	489 mm	19.3"	489 mm	19.3"	528 mm	20.8"
Service Refill Capacities:						
Fuel Tank	242 L	64 U.S. gal	332 L	88 U.S. gal	332 L	88 U.S. gal
Diesel Exhaust Fluid Refill Capacity	15 L	4 U.S. gal	15 L	4 U.S. gal	15 L	4 U.S. gal
Crankcase	11.6 L	3.1 U.S. gal	11.6 L	3.1 U.S. gal	11.6 L	3.1 U.S. gal
Hydraulic Fluid	50 L	13.2 U.S. gal	50 L	13.2 U.S. gal	50 L	13.2 U.S. gal

<sup>1</sup>Theoretical gradeability calculated using rimpull, machine weight, weight transfer and slippage. Actual gradeability may vary based on site conditions and machine configuration.

<sup>2</sup>Actual performance may vary due to site conditions.

<sup>3</sup>Some markets feature a Cat C4.4 ACERT engine that meets U.S. EPA Tier 3/EU Stage IIIA equivalent emission standards.

<sup>4</sup>Some markets feature a Cat C6.6 ACERT engine that meets U.S. EPA Tier 3/EU Stage IIIA equivalent emission standards.

MODEL	CS78B <sup>3</sup>		CS79B	
Gross Power	129.5 kW	173.7 hp	129.5 kW	173.7 hp
Rated Engine RPM	2200		2200	
No. Cylinders	4		6	
Displacement	4.4 L	268 in <sup>3</sup>	6.6 L	403 in <sup>3</sup>
Engine Model	C4.4 ACERT		C6.6 ACERT	
Emission Standards	Tier 4 Final/Stage IV		Tier 3/Stage IIIA equivalent	
Speeds	2 forward/2 reverse		2 forward/2 reverse	
Max. Speed (For./Rev.)	11.4 km/h	7 mph	11.4 km/h	7 mph
Approximate Operating Weight	18 700 kg	41,214 lb	20 200 kg	44,577 lb
Theoretical Gradeability <sup>1</sup>	53%		50%	
Rimpull <sup>2</sup>	96 kN	21,582 lbf	96 kN	21,582 lbf
Drive	Drum/Rear Wheel		Drum/Rear Wheel	
Steering:				
Inside Radius	3680 mm	12'1"	3680 mm	12'1"
Outside Radius	5810 mm	19'1"	5810 mm	19'1"
Steering Angle	±34°		±34°	
Vibratory System:				
Ecc. Weight Drive	Hydraulic		Hydraulic	
Frequency	28 Hz	1680 vpm	28 Hz	1680 vpm
Amplitude:	2		2	
High Amplitude	2.10 mm	0.083"	2.10 mm	0.083"
Low Amplitude	0.98 mm	0.039"	0.98 mm	0.039"
Centrifugal Force:				
Maximum	332 kN	74,600 lb	332 kN	74,600 lb
Minimum	166 kN	37,300 lb	166 kN	37,300 lb
General Dimensions:				
Overall Width without Blade	2460 mm	8'1"	2460 mm	8'1"
Drum Width	2134 mm	7'0"	2134 mm	7'0"
Drum Diameter	1534 mm	5'0"	1534 mm	5'0"
Tires	23.1 × 26 — 12 ply floatation		23.1 × 26 — 12 ply floatation	
Overall Height	3110 mm	10'3"	3110 mm	10'3"
Wheel to Drum	2900 mm	9'7"	2900 mm	9'7"
Overall Length	6130 mm	20'1"	6130 mm	20'1"
Curb Clearance	535 mm	21.1"	535 mm	21.1"
Service Refill Capacities:				
Fuel Tank	332 L	88 U.S. gal	332 L	88 U.S. gal
Diesel Exhaust Fluid Refill Capacity	15 L	4 U.S. gal	—	—
Crankcase	11.6 L	3.1 U.S. gal	17.4 L	4.6 U.S. gal
Hydraulic Fluid	50 L	13.2 U.S. gal	50 L	13.2 U.S. gal

<sup>1</sup>Theoretical gradeability calculated using rimpull, machine weight, weight transfer and slippage. Actual gradeability may vary based on site conditions and machine configuration.

<sup>2</sup>Actual performance may vary due to site conditions.

<sup>3</sup>Some markets feature a Cat C6.6 ACERT engine that meets U.S. EPA Tier 3/EU Stage IIIA equivalent emission standards.

MODEL	CP34		CP44B	
Gross Power	55 kW	74 hp	75 kW	100.6 hp
Rated Engine RPM	2200		2200	
No. Cylinders	4		4	
Displacement	3.4 L	207 in <sup>3</sup>	3.4 L	207 in <sup>3</sup>
Engine Model	C3.4B		C3.4B	
Emission Standards	Tier 4 Final/Stage IV		Tier 4 Final/Stage IV	
Speeds	1 forward/1 reverse		2 forward/2 reverse	
Max. Speed (For./Rev.)	8.9 km/h	5.5 mph	12.3 km/h	7.6 mph
Approximate Operating Weight	4995 kg	11,000 lb	7228 kg	15,935 lb
Theoretical Gradeability <sup>1</sup>	—		55%	
Rimpull <sup>2</sup>	—		54 kN	12,140 lbf
Drive	Drum/Rear Wheel		Drum/Rear Wheel	
Steering:				
Inside Radius	2625 mm	8'7"	3050 mm	10'0"
Outside Radius	3896 mm	12'9"	4730 mm	15'6"
Steering Angle	±38°		±37°	
Vibratory System:				
Ecc. Weight Drive	Hydraulic		Hydraulic	
Frequency	35 Hz	2100 vpm	31.9 Hz	1914 vpm
Amplitude:	1		2	
High Amplitude	1.3 mm	0.05"	1.59 mm	0.063"
Low Amplitude	1.3 mm	0.05"	0.80 mm	0.031"
Centrifugal Force:				
Maximum	66.8 kN	15,000 lb	133 kN	29,900 lb
Minimum	66.8 kN	15,000 lb	67 kN	15,000 lb
General Dimensions:				
Overall Width with Blade	1575 mm	5'2"	2120 mm	7'0"
Overall Width without Blade	1393 mm	4'6"	1800 mm	5'11"
Drum Width	1270 mm	4'2"	1676 mm	5'6"
Drum Diameter over Pads	1016 mm	3'4"	1225 mm	4'0"
Tires	11.2 × 24 — 6 ply traction		14.9 × 24 — 6 ply traction	
Overall Height	2514 mm	8'2"	2850 mm	9'4"
Wheel to Drum	2240 mm	7'4"	2600 mm	8'6"
Overall Length	4580 mm	15'0"	5090 mm	16'9"
Curb Clearance	335 mm	13.2"	371 mm	14.6"
Service Refill Capacities:				
Fuel Tank	113 L	30 U.S. gal	150 L	39.6 U.S. gal
Diesel Exhaust Fluid Refill Capacity	—		18.9 L	5 U.S. gal
Crankcase	8 L	2.1 U.S. gal	9 L	2.4 U.S. gal
Hydraulic Fluid	40 L	10.6 U.S. gal	26 L	6.9 U.S. gal

<sup>1</sup>Theoretical gradeability calculated using rimpull, machine weight, weight transfer and slippage. Actual gradeability may vary based on site conditions and machine configuration.

<sup>2</sup>Actual performance may vary due to site conditions.

MODEL	CP533E		CP54B <sup>3</sup>		CP56B <sup>3</sup>	
Gross Power	97 kW	130 hp	98 kW	131 hp	117 kW	157 hp
Rated Engine RPM	2200		2200		2200	
No. Cylinders	4		4		4	
Displacement	4.4 L	268 in <sup>3</sup>	4.4 L	268 in <sup>3</sup>	4.4 L	268 in <sup>3</sup>
Engine Model	C4.4 ACERT		C4.4 ACERT		C4.4 ACERT	
Emission Standards	Tier 2/Stage II equivalent		Tier 4 Final/Stage IV		Tier 4 Final/Stage IV	
Speeds	2 forward/2 reverse		2 forward/2 reverse		2 forward/2 reverse	
Max. Speed (For./Rev.)	12 km/h	7.5 mph	11 km/h	6.8 mph	11.4 km/h	7 mph
Approximate Operating Weight	11 320 kg	24,960 lb	10 935 kg	24,096 lb	11 665 kg	25,707 lb
Theoretical Gradeability <sup>1</sup>	—		54%		57%	
Rimpull <sup>2</sup>	—		55 kN	12,365 lbf	95 kN	21,357 lbf
Drive	Drum/Rear Wheel		Drum/Rear Wheel		Drum/Rear Wheel	
Steering:						
Inside Radius	3680 mm	12'1"	3680 mm	12'1"	3680 mm	12'1"
Outside Radius	5810 mm	19'1"	5810 mm	19'1"	5810 mm	19'1"
Steering Angle	±34°		±34°		±34°	
Vibratory System:						
Ecc. Weight Drive	Hydraulic		Hydraulic		Hydraulic	
Frequency	31.9 Hz	1914 vpm	30.5 Hz	1830 vpm	30.5 Hz	1830 vpm
Amplitude:	2		2		2	
High Amplitude	1.70 mm	0.067"	1.90 mm	0.075"	2.10 mm	0.083"
Low Amplitude	0.85 mm	0.033"	0.88 mm	0.035"	0.98 mm	0.039"
Centrifugal Force:						
Maximum	266 kN	60,000 lb	266 kN	59,800 lb	301 kN	67,600 lb
Minimum	133.5 kN	30,000 lb	133 kN	29,900 lb	141 kN	31,670 lb
General Dimensions:						
Overall Width with Blade	—		—		2500 mm	8'3"
Overall Width without Blade	2286 mm	7'6"	2300 mm	7'7"	2300 mm	7'7"
Drum Width	2130 mm	7'0"	2134 mm	7'0"	2134 mm	7'0"
Drum Diameter over Pads	1549 mm	5'1"	1534 mm	5'0"	1549 mm	5'1"
Tires	23.1 × 26 — 8 ply traction		23.1 × 26 — 8 ply traction		23.1 × 26 — 8 ply traction	
Overall Height	3070 mm	10'1"	3110 mm	10'3"	3110 mm	10'3"
Wheel to Drum	2900 mm	9'6"	2900 mm	9'7"	2900 mm	9'7"
Overall Length	5510 mm	18'1"	5850 mm	19'2"	5860 mm	19'3"
Curb Clearance	521 mm	20.5"	551 mm	21.7"	506 mm	19.9"
Service Refill Capacities:						
Fuel Tank	180 L	475 U.S. gal	242 L	64 U.S. gal	242 L	64 U.S. gal
Diesel Exhaust Fluid Refill Capacity	—		15 L	4 U.S. gal	15 L	4 U.S. gal
Crankcase	9 L	2.4 U.S. gal	8.8 L	2.3 U.S. gal	11.6 L	3.1 U.S. gal
Hydraulic Fluid	60 L	16 U.S. gal	50 L	13.2 U.S. gal	50 L	13.2 U.S. gal

<sup>1</sup>Theoretical gradeability calculated using rimpull, machine weight, weight transfer and slippage. Actual gradeability may vary based on site conditions and machine configuration.

<sup>2</sup>Actual performance may vary due to site conditions.

<sup>3</sup>Some markets feature a Cat C4.4 ACERT engine that meets U.S. EPA Tier 3/EU Stage IIIA equivalent emission standards.



MODEL	CP68B <sup>3</sup>		CP74B <sup>4</sup>	
Gross Power	117 kW	157 hp	129.5 kW	173.7 hp
Rated Engine RPM	2200		2200	
No. Cylinders	4		4	
Displacement	4.4 L	268 in <sup>3</sup>	4.4 L	268 in <sup>3</sup>
Engine Model	C4.4 ACERT		C4.4 ACERT	
Emission Standards	Tier 4 Final/Stage IV		Tier 4 Final/Stage IV	
Speeds	2 forward/2 reverse		2 forward/2 reverse	
Max. Speed (For./Rev.)	11.4 km/h	7 mph	11.4 km/h	7 mph
Approximate Operating Weight	14 685 kg	32,370 lb	16 355 kg	36,048 lb
Theoretical Gradeability <sup>1</sup>	57%		57%	
Rimpull <sup>2</sup>	95 kN	21,357 lbf	96 kN	21,582 lbf
Drive	Drum/Rear Wheel		Drum/Rear Wheel	
Steering:				
Inside Radius	3680 mm	12'1"	3680 mm	12'1"
Outside Radius	5810 mm	19'1"	5810 mm	19'1"
Steering Angle	±34°		±34°	
Vibratory System:				
Ecc. Weight Drive	Hydraulic		Hydraulic	
Frequency	30.5 Hz	1830 vpm	28 Hz	1680 vpm
Amplitude:	2		2	
High Amplitude	2.10 mm	0.083"	2.10 mm	0.083"
Low Amplitude	0.98 mm	0.039"	0.98 mm	0.039"
Centrifugal Force:				
Maximum	301 kN	67,600 lb	332 kN	74,600 lb
Minimum	141 kN	31,670 lb	166 kN	37,300 lb
General Dimensions:				
Overall Width with Blade	2500 mm	8'3"	2500 mm	8'3"
Overall Width without Blade	2330 mm	7'8"	2330 mm	7'8"
Drum Width	2134 mm	7'0"	2134 mm	7'0"
Drum Diameter over Pads	1549 mm	5'1"	1549 mm	5'1"
Tires	23.1 × 26 – 8 ply traction		23.1 × 26 – 12 ply traction	
Overall Height	3110 mm	10'3"	3110 mm	10'3"
Wheel to Drum	2900 mm	9'7"	2900 mm	9'7"
Overall Length	6050 mm	19'10"	6050 mm	19'10"
Curb Clearance	497 mm	19.6"	497 mm	19.6"
Service Refill Capacities:				
Fuel Tank	242 L	64 U.S. gal	332 L	88 U.S. gal
Diesel Exhaust Fluid Refill Capacity	15 L	4 U.S. gal	15 L	4 U.S. gal
Crankcase	11.6 L	3.1 U.S. gal	11.6 L	3.1 U.S. gal
Hydraulic Fluid	50 L	13.2 U.S. gal	50 L	13.2 U.S. gal

<sup>1</sup>Theoretical gradeability calculated using rimpull, machine weight, weight transfer and slippage. Actual gradeability may vary based on site conditions and machine configuration.

<sup>2</sup>Actual performance may vary due to site conditions.

<sup>3</sup>Some markets feature a Cat C4.4 ACERT engine that meets U.S. EPA Tier 3/EU Stage IIIA equivalent emission standards.

<sup>4</sup>Some markets feature a Cat C6.6 ACERT engine that meets U.S. EPA Tier 3/EU Stage IIIA equivalent emission standards.

MODEL	CB14B		CB14B XW		CB22B	
Gross Power	16.8 kW	22.5 hp	16.8 kW	22.5 hp	27 kW	36.2 hp
Rated Engine RPM	2850		2850		2800	
No. Cylinders	3		3		3	
Displacement	1028 cm <sup>3</sup>	62.7 in <sup>3</sup>	1028 cm <sup>3</sup>	62.7 in <sup>3</sup>	1.5 L	92 in <sup>3</sup>
Engine Model	KDW1003		KDW1003		C1.5	
Emission Standards	Tier 4 Final/Stage IV		Tier 4 Final/Stage IV		Tier 4 Final/Stage IV	
Speeds	Variable		Variable		—	
Max. Speed (For./Rev.)	9.3 km/h	5.8 mph	9.3 km/h	5.8 mph	12 km/h	7.5 mph
Working Speed	0-9.3 km/h	0-5.8 mph	0-9.3 km/h	0-5.8 mph	—	
Operating Weight	1485 kg	3274 lb	1520 kg	3351 lb	2558 kg	5629 lb
Drive	—		—		Hydraulic	
Steering:						
Inside Radius	2.02 m	6.6'	1.97 m	6.4'	2670 mm	105"
Outside Radius	2.9 m	9.6'	3.0 m	9.8'	3470 mm	137"
Steering Angle	±32°		±32°		±32°	
Vibratory System:						
Ecc. Weight Drive	Hydraulic		Hydraulic		Hydraulic	
Frequency (Max.)	70 Hz	4200 vpm	65 Hz	3900 vpm	63 Hz	3780 vpm
Amplitude:	—		—		1	
High Amplitude	0.92 mm	0.036"	0.92 mm	0.036"	0.53 mm	0.021"
Centrifugal Force:						
High Amplitude	15 kN	3400 lb	15 kN	3400 lb	28.8 kN	6475 lb
General Dimensions:						
Overall Width	1000 mm	39"	1102 mm	43"	1112 mm	44"
Drum Width	900 mm	35"	1000 mm	39"	1000 mm	39"
Drum Diameter	560 mm	22"	560 mm	22"	720 mm	28"
Overall Height (ROPS)	2545 mm	100"	2545 mm	100"	2700 mm	106"
Wheelbase	1380 mm	54"	1380 mm	54"	1800 mm	71"
Overall Length	1950 mm	77"	1950 mm	77"	2575 mm	101"
Curb Clearance	400 mm	16"	400 mm	16"	620 mm	24"
Ground Clearance	220 mm	9"	220 mm	9"	285 mm	11"
Service Refill Capacities:						
Fuel Tank	23 L	6.1 U.S. gal	23 L	6.1 U.S. gal	63.5 L	16.7 U.S. gal
Crankcase	—		—		6.0 L	1.6 U.S. gal
Hydraulic Tank	—		—		18.9 L	5 U.S. gal
Sprinkler Water	100 L	26.4 U.S. gal	100 L	26.4 U.S. gal	235 L	62.1 U.S. gal

MODEL	CB24B <sup>1</sup>		CB24B XT		CC24B <sup>2</sup>		CB32B <sup>1</sup>	
Gross Power	27 kW	<b>36.2 hp</b>	27 kW	<b>36.2 hp</b>	27 kW	<b>36.2 hp</b>	27 kW	<b>36.2 hp</b>
Rated Engine RPM	<b>2800</b>		<b>2800</b>		<b>2800</b>		<b>2800</b>	
No. Cylinders	<b>3</b>		<b>3</b>		<b>3</b>		<b>3</b>	
Displacement	1.5 L	<b>92 in<sup>3</sup></b>	1.5 L	<b>92 in<sup>3</sup></b>	1.5 L	<b>92 in<sup>3</sup></b>	1.5 L	<b>92 in<sup>3</sup></b>
Engine Model	<b>C1.5</b>		<b>C1.5</b>		<b>C1.5</b>		<b>C1.5</b>	
Emission Standards	<b>Tier 4 Final/Stage IV</b>		<b>Tier 4 Final/Stage IV</b>		<b>Tier 4 Final/Stage IV</b>		<b>Tier 4 Final/Stage IV</b>	
Max. Speed (For./Rev.)	12 km/h	<b>7.5 mph</b>	12 km/h	<b>7.5 mph</b>	12 km/h	<b>7.5 mph</b>	12 km/h	<b>7.5 mph</b>
Operating Weight	2723 kg	<b>6003 lb</b>	3123 kg	<b>6885 lb</b>	2554 kg	<b>6438 lb</b>	3321 kg	<b>7320 lb</b>
Drive	<b>Hydraulic</b>		<b>Hydraulic</b>		<b>Hydraulic</b>		<b>Hydraulic</b>	
Steering:								
Inside Radius	2470 mm	<b>97"</b>	2470 mm	<b>97"</b>	2475 mm	<b>97"</b>	2370 mm	<b>93"</b>
Outside Radius	3670 mm	<b>145"</b>	3670 mm	<b>145"</b>	3675 mm	<b>145"</b>	3770 mm	<b>148"</b>
Steering Angle	<b>±32°</b>		<b>±32°</b>		<b>±32°</b>		<b>±32°</b>	
Vibratory System:								
Ecc. Weight Drive	<b>Hydraulic</b>		<b>Hydraulic</b>		<b>Hydraulic</b>		<b>Hydraulic</b>	
Frequency (Max.)	63 Hz	<b>3780 vpm</b>	63 Hz	<b>3780 vpm</b>	63 Hz	<b>3780 vpm</b>	63 Hz	<b>3780 vpm</b>
Amplitude:	<b>1</b>		<b>1</b>		<b>1</b>		<b>1</b>	
High Amplitude	0.53 mm	<b>0.021"</b>	0.53 mm	<b>0.021"</b>	0.53 mm	<b>0.021"</b>	0.53 mm	<b>0.021"</b>
Centrifugal Force:								
High Amplitude	32.8 kN	<b>7374 lb</b>	34.7 kN	<b>7801 lb</b>	34.7 kN	<b>7801 lb</b>	37.1 kN	<b>8340 lb</b>
General Dimensions:								
Overall Width	1312 mm	<b>52"</b>	1312 mm	<b>52"</b>	1312 mm	<b>52"</b>	1312 mm	<b>52"</b>
Drum Width	1200 mm	<b>47"</b>	1200 mm	<b>47"</b>	1200 mm	<b>47"</b>	1300 mm	<b>51"</b>
Drum Diameter	720 mm	<b>28"</b>	720 mm	<b>28"</b>	720 mm	<b>28"</b>	720 mm	<b>28"</b>
Tires	—		—		<b>6-ply</b>		—	
Overall Height (ROPS)	2700 mm	<b>106"</b>	2700 mm	<b>106"</b>	2700 mm	<b>106"</b>	2700 mm	<b>106"</b>
Wheelbase	1800 mm	<b>71"</b>	1800 mm	<b>71"</b>	1800 mm	<b>71"</b>	1800 mm	<b>71"</b>
Overall Length	2575 mm	<b>101"</b>	2575 mm	<b>101"</b>	2575 mm	<b>101"</b>	2575 mm	<b>101"</b>
Curb Clearance	620 mm	<b>24"</b>	620 mm	<b>24"</b>	620 mm	<b>24"</b>	620 mm	<b>24"</b>
Ground Clearance	285 mm	<b>11"</b>	285 mm	<b>11"</b>	285 mm	<b>11"</b>	285 mm	<b>11"</b>
Service Refill Capacities:								
Fuel Tank	63.5 L	<b>16.7 U.S. gal</b>	63.5 L	<b>16.7 U.S. gal</b>	63.5 L	<b>16.7 U.S. gal</b>	63.5 L	<b>16.7 U.S. gal</b>
Crankcase	6.0 L	<b>1.6 U.S. gal</b>	6.0 L	<b>1.6 U.S. gal</b>	6.0 L	<b>1.6 U.S. gal</b>	6.0 L	<b>1.6 U.S. gal</b>
Hydraulic Tank	18.9 L	<b>5 U.S. gal</b>	18.9 L	<b>5 U.S. gal</b>	18.9 L	<b>5 U.S. gal</b>	18.9 L	<b>5 U.S. gal</b>
Sprinkler Water	235 L	<b>62.1 U.S. gal</b>	235 L	<b>62.1 U.S. gal</b>	235 L	<b>62.1 U.S. gal</b>	235 L	<b>62.1 U.S. gal</b>

<sup>1</sup>400 kg (882 lb) ballast weight kit available.

<sup>2</sup>Combi Asphalt Compactor with steel drum on front and rubber tires on rear.

MODEL	CB34B <sup>1</sup>		CB36B		CC34B <sup>2</sup>	
Gross Power	36.4 kW	<b>48.8 hp</b>	36.4 kW	<b>48.8 hp</b>	36.4 kW	<b>48.8 hp</b>
Rated Engine RPM	<b>2400</b>		<b>2400</b>		<b>2400</b>	
No. Cylinders	<b>4</b>		<b>4</b>		<b>4</b>	
Displacement	2.2 L	<b>134 in<sup>3</sup></b>	2.2 L	<b>134 in<sup>3</sup></b>	2.2 L	<b>134 in<sup>3</sup></b>
Engine Model	<b>C2.2</b>		<b>C2.2</b>		<b>C2.2</b>	
Emission Standards	<b>Tier 4 Final/Stage IV</b>		<b>Tier 4 Final/Stage IV</b>		<b>Tier 4 Final/Stage IV</b>	
Max. Speed (For./Rev.)	12 km/h	<b>7.5 mph</b>	12 km/h	<b>7.5 mph</b>	12 km/h	<b>7.5 mph</b>
Operating Weight	3699 kg	<b>8155 lb</b>	3803 kg	<b>8385 lb</b>	3378 kg	<b>7446 lb</b>
Shipping Weight	3466 kg	<b>7641 lb</b>	3570 kg	<b>7871 lb</b>	3145 kg	<b>6932 lb</b>
Drive	<b>Hydraulic</b>		<b>Hydraulic</b>		<b>Hydraulic</b>	
Steering:						
Inside Radius	2932 mm	<b>115"</b>	2897 mm	<b>114"</b>	2937 mm	<b>116"</b>
Outside Radius	4232 mm	<b>167"</b>	4297 mm	<b>169"</b>	4237 mm	<b>169"</b>
Steering Angle	<b>±32°</b>		<b>±32°</b>		<b>±32°</b>	
Vibratory System:						
Ecc. Weight Drive	<b>Hydraulic</b>		<b>Hydraulic</b>		<b>Hydraulic</b>	
Frequency	55 Hz	<b>3300 vpm</b>	55 Hz	<b>3300 vpm</b>	55 Hz	<b>3300 vpm</b>
Amplitude:	<b>1</b>		<b>1</b>		<b>1</b>	
High Amplitude	0.50 mm	<b>0.020"</b>	0.50 mm	<b>0.020"</b>	0.50 mm	<b>0.020"</b>
Centrifugal Force:						
High Amplitude	31.6 kN	<b>7104 lb</b>	33.5 kN	<b>7531 lb</b>	31.6 kN	<b>7104 lb</b>
Low Amplitude	24.1 kN	<b>5418 lb</b>	25.5 kN	<b>5733 lb</b>	24.1 kN	<b>5418 lb</b>
General Dimensions:						
Overall Width	1400 mm	<b>55"</b>	1500 mm	<b>59"</b>	1400 mm	<b>55"</b>
Drum Width	1300 mm	<b>51"</b>	1400 mm	<b>55"</b>	1300 mm	<b>51"</b>
Drum Diameter	800 mm	<b>32"</b>	800 mm	<b>32"</b>	800 mm	<b>32"</b>
Tires	—		—		<b>6-ply</b>	
Overall Height (ROPS)	2765 mm	<b>109"</b>	2765 mm	<b>109"</b>	2765 mm	<b>109"</b>
Wheelbase	2050 mm	<b>81"</b>	2050 mm	<b>81"</b>	2050 mm	<b>81"</b>
Overall Length	2859 mm	<b>113"</b>	2859 mm	<b>113"</b>	2859 mm	<b>113"</b>
Curb Clearance	625 mm	<b>25"</b>	625 mm	<b>25"</b>	625 mm	<b>25"</b>
Ground Clearance	284 mm	<b>11"</b>	284 mm	<b>11"</b>	284 mm	<b>11"</b>
Service Refill Capacities:						
Fuel Tank	90.7 L	<b>24 U.S. gal</b>	90.7 L	<b>24 U.S. gal</b>	90.7 L	<b>24 U.S. gal</b>
Crankcase	10.6 L	<b>2.8 U.S. gal</b>	10.6 L	<b>2.8 U.S. gal</b>	10.6 L	<b>2.8 U.S. gal</b>
Hydraulic Tank	18.9 L	<b>5 U.S. gal</b>	18.9 L	<b>5 U.S. gal</b>	18.9 L	<b>5 U.S. gal</b>
Sprinkler Water	308 L	<b>81 U.S. gal</b>	308 L	<b>81 U.S. gal</b>	308 L	<b>81 U.S. gal</b>

<sup>1</sup>400 kg (882 lb) ballast weight kit available.

<sup>2</sup>Combi Asphalt Compactor with steel drum on front and rubber tires on rear.

MODEL	CB44B <sup>1,3</sup>		CD44B <sup>2,4</sup>		CB46B <sup>1,4</sup>	
Gross Power	75 kW	100 hp	75 kW	100 hp	75 kW	100 hp
Rated Engine RPM	2200		2200		2200	
No. Cylinders	4		4		4	
Displacement	3.4 L	207.5 in <sup>3</sup>	3.4 L	207.5 in <sup>3</sup>	3.4 L	207.5 in <sup>3</sup>
Engine Model	C3.4B		C3.4B		C3.4B	
Emission Standards	Tier 4 Final/ Stage IV		Tier 4 Final/ Stage IV		Tier 4 Interim/ Stage IIIB equivalent	
Speeds	2 forward/2 reverse		2 forward/2 reverse		2 forward/2 reverse	
Max. Speed (For./Rev.)	12 km/h	7.5 mph	12 km/h	7.5 mph	12 km/h	7.5 mph
Working Speed	0-12 km/h	0-7.5 mph	0-12 km/h	0-7.5 mph	0-12 km/h	0-7.5 mph
Approximate Operating Weight	7990 kg	17,615 lb	8390 kg	18,497 lb	9250 kg	20,343 lb
Drive	Hydraulic		Hydraulic		Hydraulic	
Steering:						
Inside Radius	4351 mm	14'3"	2942 mm	9'9"	4250 mm	13'11"
Outside Radius	5851 mm	19'2"	4441 mm	14'8"	5950 mm	19'6"
Steering Angle	±36°		±25°		±36°	
Vibratory System:						
Ecc. Weight Drive	Hydraulic		Hydraulic		Hydraulic	
Frequency	53.3 Hz	3200 vpm	42/53.3 Hz	2520/ 3200 vpm	53.3/63.3 Hz	3200/ 3800 vpm
Amplitude:						
High Amplitude	0.64 mm	0.025"	0.62 mm	0.024"	0.56 mm	0.022"
Low Amplitude	0.25 mm	0.010"	0.31 mm	0.012"	0.27 mm	0.010"
Centrifugal Force:						
High Amplitude	76.9 kN	17,288 lb	73.8 kN	16,591 lb	78.3 kN	17,603 lb
Low Amplitude	30.2 kN	6789 lb	59.2 kN	13,309 lb	53.3 kN	11,982 lb
General Dimensions:						
Overall Width	1670 mm	5'6"	1664 mm	5'6"	1862 mm	6'1"
Drum Width	1500 mm	4'11"	1500 mm	4'11"	1700 mm	5'7"
Drum Diameter	1100 mm	3'7"	1100 mm	3'7"	1108 mm	3'8"
Overall Height (ROPS)	2980 mm	9'9"	2940 mm	9'8"	2980 mm	9'9"
Wheelbase	3300 mm	10'10"	3120 mm	10'3"	3300 mm	10'10"
Overall Length	4565 mm	14'11"	4284 mm	13'10"	4565 mm	14'11"
Curb Clearance	898 mm	35"	663 mm	26"	934 mm	37"
Ground Clearance	226 mm	9"	273 mm	10"	268 mm	10"
Service Refill Capacities:						
Fuel Tank	208 L	55 U.S. gal	135 L	36 U.S. gal	208 L	55 U.S. gal
Diesel Exhaust Fluid Refill Capacity	18.9 L	5 U.S. gal	18.9 L	5 U.S. gal	18.9 L	5 U.S. gal
Crankcase	9 L	2.4 U.S. gal	9 L	2.4 U.S. gal	9 L	2.4 U.S. gal
Hydraulic Tank	36 L	9.5 U.S. gal	36 L	9.5 U.S. gal	36 L	9.5 U.S. gal
Sprinkler Water	742 L	196 U.S. gal	600 L	159 U.S. gal	837 L	221 U.S. gal

<sup>1</sup>Weights reflect solid drum configuration with ROPS/FOPS canopy.

<sup>2</sup>Weights reflect split drum configuration with ROPS/FOPS cab.

<sup>3</sup>With 5-Amp vibratory system. Other systems available.

<sup>4</sup>With Dual Amp — Dual Frequency vibratory system. Other systems available.

MODEL	CB54B <sup>1,3</sup>		CD54B <sup>2,4</sup>	
Gross Power	98 kW	131 hp	75 kW	100 hp
Rated Engine RPM	2200		2200	
No. Cylinders	4		4	
Displacement	4.4 L	269 in <sup>3</sup>	3.4 L	207.5 in <sup>3</sup>
Engine Model	C4.4 ACERT		C3.4B	
Emission Standards	Tier 4 Final/Stage IV		Tier 4 Final/Stage IV	
Speeds	2 forward/2 reverse		2 forward/2 reverse	
Max. Speed (For./Rev.)	12 km/h	7.5 mph	12 km/h	7.5 mph
Working Speed	0-12 km/h	0-7.5 mph	0-12 km/h	0-7.5 mph
Approximate Operating Weight	9500 kg	20,944 lb	10 120 kg	22,311 lb
Drive	Hydraulic		Hydraulic	
Steering:				
Inside Radius	4250 mm	13'11"	2842 mm	9'4"
Outside Radius	5950 mm	19'6"	4541 mm	14'11"
Steering Angle	±36°		±25°	
Vibratory System:				
Ecc. Weight Drive	Hydraulic		Hydraulic	
Frequency	43 Hz	2580 vpm	42/53.3 Hz	2520/ 3200 vpm
Amplitude:				
High Amplitude	1.06 mm	0.042"	0.61 mm	0.023"
Low Amplitude	0.34 mm	0.013"	0.33 mm	0.013"
Centrifugal Force:				
High Amplitude	107 kN	24,055 lb	86.7 kN	19,491 lb
Low Amplitude	34.6 kN	7778 lb	75.5 kN	16,973 lb
General Dimensions:				
Overall Width	1872 mm	6'2"	1874 mm	6'2"
Drum Width	1700 mm	5'7"	1700 mm	5'7"
Drum Diameter	1200 mm	3'11"	1200 mm	3'11"
Overall Height (ROPS)	2982 mm	9'9"	2985 mm	9'9"
Wheelbase	3300 mm	10'10"	3120 mm	10'3"
Overall Length	4565 mm	14'11"	4322 mm	14'2"
Curb Clearance	934 mm	37"	808 mm	31"
Ground Clearance	268 mm	10"	272 mm	10"
Service Refill Capacities:				
Fuel Tank	208 L	55 U.S. gal	191 L	50 U.S. gal
Diesel Exhaust Fluid Refill Capacity	18.9 L	5 U.S. gal	18.9 L	5 U.S. gal
Crankcase	9 L	2.4 U.S. gal	9 L	2.4 U.S. gal
Hydraulic Tank	36 L	9.5 U.S. gal	36 L	9.5 U.S. gal
Sprinkler Water	837 L	221 U.S. gal	750 L	198 U.S. gal

<sup>1</sup>Weights reflect solid drum configuration with ROPS/FOPS canopy.

<sup>2</sup>Weights reflect split drum configuration with ROPS/FOPS cab.

<sup>3</sup>With 5-Amp vibratory system. Other systems available.

<sup>4</sup>With Dual Amp — Dual Frequency vibratory system. Other systems available.

MODEL	CB64B		CB66B		CB68B	
Gross Power	106 kW	<b>142 hp</b>	106 kW	<b>142 hp</b>	106 kW	<b>142 hp</b>
Rated Engine RPM	<b>2200</b>		<b>2200</b>		<b>2200</b>	
No. Cylinders	<b>4</b>		<b>4</b>		<b>4</b>	
Displacement	4.4 L		4.4 L		4.4 L	
Engine Model	<b>C4.4 ACERT</b>		<b>C4.4 ACERT</b>		<b>C4.4 ACERT</b>	
Emission Standards	<b>Tier 4 Final/Stage IV</b>		<b>Tier 4 Final/Stage IV</b>		<b>Tier 4 Final/Stage IV</b>	
Speeds	<b>2 forward/2 reverse</b>		<b>2 forward/2 reverse</b>		<b>2 forward/2 reverse</b>	
Max. Speed (For./Rev.)	13 km/h	<b>8 mph</b>	13 km/h	<b>8 mph</b>	13 km/h	<b>8 mph</b>
Working Speed	0-13 km/h	<b>0-8 mph</b>	0-13 km/h	<b>0-8 mph</b>	0-13 km/h	<b>0-8 mph</b>
Approximate Operating Weight	12 000 kg	<b>26,455 lb</b>	13 000 kg	<b>28,660 lb</b>	14 000 kg	<b>30,865 lb</b>
Drive	<b>Hydraulic</b>		<b>Hydraulic</b>		<b>Hydraulic</b>	
Steering:						
Inside Radius	4200 mm	<b>13'10"</b>	4100 mm	<b>13'8"</b>	4100 mm	<b>13'8"</b>
Outside Radius	6200 mm	<b>20'5"</b>	6230 mm	<b>20'8"</b>	6230 mm	<b>20'8"</b>
Steering Angle	<b>±36.5°</b>		<b>±36.5°</b>		<b>±36.5°</b>	
Vibratory System:						
Ecc. Weight Drive	<b>Hydraulic</b>		<b>Hydraulic</b>		<b>Hydraulic</b>	
Frequency	42 Hz	<b>2520 vpm</b>	42 Hz	<b>2520 vpm</b>	42 Hz	<b>2520 vpm</b>
Amplitude:						
High Amplitude	0.96 mm	<b>0.038"</b>	0.96 mm	<b>0.038"</b>	0.96 mm	<b>0.038"</b>
Low Amplitude	0.30 mm	<b>0.012"</b>	0.30 mm	<b>0.012"</b>	0.30 mm	<b>0.012"</b>
Centrifugal Force:						
High Amplitude	110 kN	<b>24,728 lb</b>	110 kN	<b>24,728 lb</b>	110 kN	<b>24,728 lb</b>
Low Amplitude	34.7 kN	<b>7800 lb</b>	34.7 kN	<b>7800 lb</b>	34.7 kN	<b>7800 lb</b>
General Dimensions:						
Overall Width	2325 mm	<b>7'8"</b>	2325 mm	<b>7'8"</b>	2325 mm	<b>7'8"</b>
Drum Width	2000 mm	<b>6'7"</b>	2130 mm	<b>7'0"</b>	2130 mm	<b>7'0"</b>
Drum Diameter	1300 mm	<b>4'3"</b>	1300 mm	<b>4'3"</b>	1300 mm	<b>4'3"</b>
Overall Height (ROPS)	3050 mm	<b>10'0"</b>	3050 mm	<b>10'0"</b>	3050 mm	<b>10'0"</b>
Wheelbase	3450 mm	<b>11'4"</b>	3450 mm	<b>11'4"</b>	3450 mm	<b>11'4"</b>
Overall Length	4600 mm	<b>15'1"</b>	4600 mm	<b>15'1"</b>	4600 mm	<b>15'1"</b>
Curb Clearance	723 mm	<b>28.5"</b>	723 mm	<b>28.5"</b>	723 mm	<b>28.5"</b>
Ground Clearance	295 mm	<b>11.6"</b>	295 mm	<b>11.6"</b>	295 mm	<b>11.6"</b>
Service Refill Capacities:						
Fuel Tank	250 L	<b>66 U.S. gal</b>	250 L	<b>66 U.S. gal</b>	250 L	<b>66 U.S. gal</b>
Diesel Exhaust Fluid Refill Capacity	18.9 L	<b>5 U.S. gal</b>	18.9 L	<b>5 U.S. gal</b>	18.9 L	<b>5 U.S. gal</b>
Crankcase	8.1 L	<b>2.1 U.S. gal</b>	8.1 L	<b>2.1 U.S. gal</b>	8.1 L	<b>2.1 U.S. gal</b>
Hydraulic Tank	36 L	<b>9.5 U.S. gal</b>	36 L	<b>9.5 U.S. gal</b>	36 L	<b>9.5 U.S. gal</b>
Sprinkler Water	1000 L	<b>264 U.S. gal</b>	1000 L	<b>264 U.S. gal</b>	1000 L	<b>264 U.S. gal</b>

MODEL	CW14 <sup>2</sup>		CW16 <sup>2</sup>		PS360C <sup>3</sup>		CW34	
Gross Power	75 kW	<b>100 hp</b>	75 kW	<b>100.6 hp</b>	98 kW	<b>130 hp</b>	98 kW	<b>131 hp</b>
Rated Engine RPM	<b>2200</b>		<b>2200</b>		<b>2200</b>		<b>2200</b>	
No. Cylinders	<b>4</b>		<b>4</b>		<b>4</b>		<b>4</b>	
Displacement	3.4 L	<b>207.5 in<sup>3</sup></b>	3.4 L	<b>207.5 in<sup>3</sup></b>	4.4 L	<b>269 in<sup>3</sup></b>	4.4 L	<b>269 in<sup>3</sup></b>
Engine Model	<b>C3.4B</b>		<b>C3.4B<sup>4</sup></b>		<b>3054C ATAAC</b>		<b>C4.4 ACERT</b>	
Emission Standards	<b>Tier 4 Final/Stage IV</b>		—		<b>Tier 2/Stage II equivalent</b>		<b>Tier 4 Final/Stage IV</b>	
Speeds	—		—		<b>2 forward/2 reverse</b>		—	
Max. Speed (For./Rev.)	18 km/h	<b>11 mph</b>	19 km/h	<b>12 mph</b>	18 km/h	<b>11 mph</b>	19 km/h	<b>12 mph</b>
Working Speed	0-18 km/h	<b>0-11 mph</b>	0-19 km/h	<b>0-12 mph</b>	8 km/h	<b>5 mph</b>	0-19 km/h	<b>0-12 mph</b>
Wheel Configuration	<b>5 front/4 rear</b>		<b>5 front/4 rear</b>		<b>3 front/4 rear</b>		<b>4 front/4 rear</b>	
Tires	<b>8.50/90 × 15-6 ply</b>		<b>12-ply 7.5 × 15 Radial or 14-ply 7.5 × 15 Bias</b>		<b>14/70 × 20-20 ply</b>		<b>13/80-R20</b>	
Operating Weight Empty (No ballast) <sup>1</sup>	4885 kg	<b>10,775 lb</b>	5200 kg	<b>11,464 lb</b>	8580 kg	<b>18,915 lb</b>	10 000 kg	<b>22,050 lb</b>
Operating Weight Full (Max. ballast) <sup>1</sup>	12 940 kg	<b>28,535 lb</b>	15 000 kg	<b>33,069 lb</b>	18 500 kg	<b>40,785 lb</b>	27 000 kg	<b>59,525 lb</b>
Maximum Weight per Wheel	1440 kg	<b>3180 lb</b>	1670 kg	<b>3682 lb</b>	3571 kg	<b>7873 lb</b>	3380 kg	<b>7452 lb</b>
Shipping Weight	4805 kg	<b>10,580 lb</b>	5200 kg	<b>11,464 lb</b>	8500 kg	<b>18,740 lb</b>	—	
Drive	<b>Hydraulic</b>		<b>Hydraulic</b>		<b>Hydraulic</b>		<b>Hydraulic</b>	
Steering:								
Inside Radius	4648 mm	<b>15'3"</b>	4648 mm	<b>15'3"</b>	3470 mm	<b>11'5"</b>	6097 mm	<b>20'0"</b>
Outside Radius	6453 mm	<b>21'2"</b>	6453 mm	<b>21'2"</b>	6700 mm	<b>22'0"</b>	8672 mm	<b>28'5"</b>
General Dimensions:								
Overall Width	1740 mm	<b>5'8"</b>	1754 mm	<b>5'9"</b>	2280 mm	<b>7'6"</b>	2160 mm	<b>7'1"</b>
Rolling Width	1740 mm	<b>5'8"</b>	1754 mm	<b>5'9"</b>	2280 mm	<b>7'6"</b>	2090 mm	<b>6'10"</b>
Tire Width	191 mm	<b>7.5"</b>	191 mm	<b>7.5"</b>	368 mm	<b>14.5"</b>	298 mm	<b>11.7"</b>
Tire Overlap	13 mm	<b>0.5"</b>	36 mm	<b>1.42"</b>	58 mm	<b>2.25"</b>	42 mm	<b>1.7"</b>
Overall Height (ROPS)	3000 mm	<b>9'10"</b>	3000 mm	<b>9'10"</b>	3200 mm	<b>10'6"</b>	3000 mm	<b>9'10"</b>
Wheelbase	3340 mm	<b>10'11"</b>	3340 mm	<b>10'11"</b>	3650 mm	<b>12'0"</b>	3900 mm	<b>12'9"</b>
Overall Length	4290 mm	<b>14'1"</b>	4290 mm	<b>14'1"</b>	4870 mm	<b>16'0"</b>	5350 mm	<b>17'6"</b>
Ground Clearance	267 mm	<b>10.5"</b>	267 mm	<b>10.5"</b>	252 mm	<b>10"</b>	260 mm	<b>10"</b>
Service Refill Capacities:								
Fuel Tank	173 L	<b>45.6 U.S. gal</b>	146 L	<b>38 U.S. gal</b>	200 L	<b>52 U.S. gal</b>	270 L	<b>71 U.S. gal</b>
Crankcase	7.3 L	<b>1.9 U.S. gal</b>	9.5 L	<b>2.5 U.S. gal</b>	7.3 L	<b>1.9 U.S. gal</b>	9 L	<b>2.4 U.S. gal</b>
Hydraulic Fluid	54.9 L	<b>14.5 U.S. gal</b>	31.9 L	<b>8.4 U.S. gal</b>	90 L	<b>23.7 U.S. gal</b>	32 L	<b>8.5 U.S. gal</b>
Sprinkler Water	394 L	<b>104 U.S. gal</b>	348 L	<b>92 U.S. gal</b>	394 L	<b>104 U.S. gal</b>	380 L	<b>100 U.S. gal</b>

<sup>1</sup>With ROPS.<sup>2</sup>11-wheel configuration available.<sup>3</sup>Combined ballast available for an operating weight of 25 022 kg (55,115 lb).<sup>4</sup>C4.4 ACERT engine standard in certain markets.



**Pneumatic Tires — Bias Ply and Radial**

Model	Tire Size	Ply Rating	Tire Inflation Pressure			
			Minimum Pressure		Maximum Pressure	
			kPa	psi	kPa	psi
CW14	8.5 × 15	6	275	40	344	50
	7.5 × 15	12	344	50	757	110
	7.5 × 15	14	344	50	862	125
CW16	7.5R15	Radial	296	43	480	70
	7.5 × 15	12-ply Radial	344	50	757	110
	7.5 × 15	14-ply Bias	344	50	862	125
CW34	13/80-R20	Radial	300	44	900	131
PS360C	14/70 × 20	20	241	35	757	110

**Ballast Configurations**

Model	Load	Ballast Configuration					
		Empty	Water Only	Steel Only	Wet Sand Only	Steel and Water	Steel and Wet Sand
CW14	Wheel Load	545 kg	970 kg	*	1440 kg	*	*
		<b>1200 lb</b>	<b>2145 lb</b>	*	<b>3180 lb</b>	*	*
	Machine Weight	4885 kg	8710 kg	*	12 940 kg	*	*
		<b>10,775 lb</b>	<b>19,205 lb</b>	*	<b>28,535 lb</b>	*	*
CW14 (11-wheel)	Wheel Load	450 kg	798 kg	*	1183 kg	*	*
		<b>993 lb</b>	<b>1760 lb</b>	*	<b>2608 lb</b>	*	*
	Machine Weight	4955 kg	8780 kg	*	13 010 kg	*	*
		<b>10,925 lb</b>	<b>19,355 lb</b>	*	<b>28,685 lb</b>	*	*
CW14 (Heavy Weight Option)	Wheel Load	457 kg	805 kg	*	1189 kg	*	*
		<b>1008 lb</b>	<b>1775 lb</b>	*	<b>2621 lb</b>	*	*
	Machine Weight	5025 kg	8850 kg	*	13 080 kg	*	*
		<b>11,078 lb</b>	<b>19,511 lb</b>	*	<b>28,836 lb</b>	*	*
CW16	Wheel Load	580 kg	970 kg	940 kg	1360 kg	1310 kg	1670 kg
		<b>1279 lb</b>	<b>2139 lb</b>	<b>2072 lb</b>	<b>2998 lb</b>	<b>2888 lb</b>	<b>3682 lb</b>
	Machine Weight	5200 kg	8700 kg	8500 kg	12 200 kg	11 750 kg	15 000 kg
		<b>11,464 lb</b>	<b>19,180 lb</b>	<b>18,739 lb</b>	<b>26,896 lb</b>	<b>25,904 kg</b>	<b>33,069 lb</b>
CW16 (11-wheel)	Wheel Load	480 kg	800 kg	780 kg	1110 kg	1060 kg	1350 kg
		<b>1058 lb</b>	<b>1764 lb</b>	<b>1720 lb</b>	<b>2447 lb</b>	<b>2337 lb</b>	<b>2976 lb</b>
	Machine Weight	5300 kg	8800 kg	8600 kg	12 300 kg	11 750 kg	14 900 kg
		<b>11,685 lb</b>	<b>19,400 lb</b>	<b>18,960 lb</b>	<b>27,117 lb</b>	<b>25,904 kg</b>	<b>32,849 lb</b>
CW34	Wheel Load	1250 kg	1620 kg	2820 kg	2000 kg	3080 kg	3375 kg
		<b>2756 lb</b>	<b>3572 lb</b>	<b>6217 lb</b>	<b>4409 lb</b>	<b>6790 lb</b>	<b>7441 lb</b>
	Machine Weight	10 000 kg	13 000 kg	22 550 kg	16 000 kg	24 700 kg	27 000 kg
		<b>22,050 lb</b>	<b>28,660 lb</b>	<b>49,715 lb</b>	<b>35,275 lb</b>	<b>54,450 kg</b>	<b>59,525 lb</b>
PS360C	Wheel Load	1215 kg	1930 kg	2285 kg	2645 kg	2855 kg	3570 kg
		<b>2675 lb</b>	<b>4250 lb</b>	<b>5040 lb</b>	<b>5830 lb</b>	<b>6300 lb</b>	<b>7870 lb</b>
	Machine Weight	8500 kg	13 500 kg	15 995 kg	18 500 kg	20 000 kg	25 000 kg
		<b>18,740 lb</b>	<b>29,760 lb</b>	<b>35,265 lb</b>	<b>40,785 lb</b>	<b>44,090 lb</b>	<b>55,115 lb</b>

\*Configuration not available.

- Specifications
- Maximum Ground Pressures
- Ground Contact Pressures

## Pneumatic Tire Compactors

### Maximum Ground Pressures

Model	Ply Rating	Empty	Water Only	Steel Only	Wet Sand Only	Steel and Water	Steel and Wet Sand
CW14	6	469 kPa <b>68 psi</b>	689 kPa <b>100 psi</b>	* *	655 kPa <b>95 psi</b>	* *	* *
	12	469 kPa <b>68 psi</b>	724 kPa <b>105 psi</b>	* *	758 kPa <b>110 psi</b>	* *	* *
	14	469 kPa <b>68 psi</b>	1041 kPa <b>151 psi</b>	* *	972 kPa <b>141 psi</b>	* *	* *

\*Configuration not available.

### Ground Contact Pressures — CW16

Average Wheel Load	Tire Pressures: 12-Ply Radial						
	344 kPa 50 psi	413 kPa 60 psi	482 kPa 70 psi	550 kPa 80 psi	619 kPa 90 psi	688 kPa 100 psi	757 kPa 110 psi
545 kg <b>1200 lb</b>	236 kPa <b>34 psi</b>	266 kPa <b>39 psi</b>	284 kPa <b>41 psi</b>	306 kPa <b>44 psi</b>	317 kPa <b>46 psi</b>	317 kPa <b>46 psi</b>	344 kPa <b>50 psi</b>
970 kg <b>2145 lb</b>	250 kPa <b>36 psi</b>	284 kPa <b>41 psi</b>	314 kPa <b>46 psi</b>	343 kPa <b>50 psi</b>	369 kPa <b>54 psi</b>	378 kPa <b>55 psi</b>	410 kPa <b>60 psi</b>
1440 kg <b>3180 lb</b>	280 kPa <b>41 psi</b>	304 kPa <b>44 psi</b>	331 kPa <b>48 psi</b>	358 kPa <b>52 psi</b>	390 kPa <b>57 psi</b>	405 kPa <b>59 psi</b>	607 kPa <b>88 psi</b>

Average Wheel Load	Tire Pressures: 14-Ply Bias								
	344 kPa 50 psi	413 kPa 60 psi	482 kPa 70 psi	550 kPa 80 psi	619 kPa 90 psi	688 kPa 100 psi	757 kPa 110 psi	826 kPa 120 psi	862 kPa 125 psi
545 kg <b>1200 lb</b>	243 kPa <b>35 psi</b>	266 kPa <b>39 psi</b>	284 kPa <b>41 psi</b>	295 kPa <b>43 psi</b>	317 kPa <b>46 psi</b>	330 kPa <b>48 psi</b>	344 kPa <b>50 psi</b>	359 kPa <b>52 psi</b>	367 kPa <b>53 psi</b>
970 kg <b>2145 lb</b>	259 kPa <b>38 psi</b>	295 kPa <b>43 psi</b>	321 kPa <b>47 psi</b>	343 kPa <b>50 psi</b>	369 kPa <b>54 psi</b>	388 kPa <b>56 psi</b>	420 kPa <b>60 psi</b>	421 kPa <b>61 psi</b>	427 kPa <b>62 psi</b>
1440 kg <b>3180 lb</b>	273 kPa <b>40 psi</b>	312 kPa <b>45 psi</b>	336 kPa <b>49 psi</b>	364 kPa <b>53 psi</b>	390 kPa <b>57 psi</b>	413 kPa <b>60 psi</b>	437 kPa <b>64 psi</b>	465 kPa <b>68 psi</b>	475 kPa <b>69 psi</b>

#### NOTES:

1. Each tire type has a unique pressure distribution which varies with both tire inflation pressure and wheel load. The distribution of pressure along both transverse and longitudinal profiles is rarely uniform.
2. The measurements in this table represent the peak pressures measured in a transverse profile at each of the ballast conditions at maximum tire inflation pressure.
3. For most applications, it can be assumed that normal operation of the pneumatic compactor will result in the ground being subjected to pressures near the maximum during at least one machine pass.

**Ground Contact Pressures — CW34**

Average Wheel Load	Tire Pressure							
	300 kPa 44 psi	400 kPa 58 psi	500 kPa 73 psi	600 kPa 87 psi	700 kPa 102 psi	800 kPa 116 psi	850 kPa 123 psi	900 kPa 131 psi
1500 kg <b>3307 lb</b>	242 kPa <b>35 psi</b>	309 kPa <b>45 psi</b>	406 kPa <b>59 psi</b>	612 kPa <b>89 psi</b>	680 kPa <b>99 psi</b>	1038 kPa <b>151 psi</b>	1265 kPa <b>184 psi</b>	1587 kPa <b>230 psi</b>
2000 kg <b>4410 lb</b>	260 kPa <b>38 psi</b>	299 kPa <b>43 psi</b>	357 kPa <b>52 psi</b>	462 kPa <b>67 psi</b>	498 kPa <b>72 psi</b>	628 kPa <b>91 psi</b>	691 kPa <b>100 psi</b>	764 kPa <b>111 psi</b>
2500 kg <b>5512 lb</b>	308 kPa <b>45 psi</b>	322 kPa <b>47 psi</b>	360 kPa <b>52 psi</b>	429 kPa <b>62 psi</b>	458 kPa <b>66 psi</b>	539 kPa <b>78 psi</b>	577 kPa <b>84 psi</b>	618 kPa <b>90 psi</b>
3000 kg <b>6614 lb</b>	397 kPa <b>58 psi</b>	369 kPa <b>54 psi</b>	386 kPa <b>56 psi</b>	433 kPa <b>63 psi</b>	457 kPa <b>66 psi</b>	516 kPa <b>75 psi</b>	543 kPa <b>79 psi</b>	573 kPa <b>83 psi</b>
3375 kg <b>7441 lb</b>	518 kPa <b>75 psi</b>	423 kPa <b>61 psi</b>	418 kPa <b>61 psi</b>	448 kPa <b>65 psi</b>	469 kPa <b>68 psi</b>	517 kPa <b>75 psi</b>	539 kPa <b>78 psi</b>	564 kPa <b>82 psi</b>

**NOTES:**

1. Each tire type has a unique pressure distribution which varies with both tire inflation pressure and wheel load. The distribution of pressure along both transverse and longitudinal profiles is rarely uniform.
2. The measurements in this table represent the peak pressures measured in a transverse profile at each of the ballast conditions at maximum tire inflation pressure.
3. For most applications, it can be assumed that normal operation of the pneumatic compactor will result in the ground being subjected to pressures near the maximum during at least one machine pass.

The tables in this section give production estimates for the following assumed conditions:

Nominal machine travel speed: 6.4 km/h (4.0 mph)

Overlap of rolling width: 15.2 cm (6.0 inches)

Table values give **representative** production rates for three common construction conditions: trenches, roads, and wide areas (> 15 m, or 50 ft).

Model	Drum Width		Lift Thickness		Passes Required	Production Estimates			
	cm	in	cm	in		3.7 m (12 ft) Trench	9.15 m (30 ft) Road Base	Wide Areas	
CS423E, CS44, CS44B	167.6	66	10.2	4	4	m <sup>3</sup> /hr yds <sup>3</sup> /hr	159 209	249 326	249 326
CS533E, CS54, CS56, CS54B, CS56B, CS64B, CS66B	213.4	84	15.2	6	6	m <sup>3</sup> /hr yds <sup>3</sup> /hr	239 313	299 391	324 424
CS64, CS68B	213.4	84	15.2	6	5	m <sup>3</sup> /hr yds <sup>3</sup> /hr	— 489	373 489	405 530
CS74, CS74B	213.4	84	15.2	6	4	m <sup>3</sup> /hr yds <sup>3</sup> /hr	— 587	448 587	486 636
CS76, CS76B	213.4	84	15.2	12	6	m <sup>3</sup> /hr yds <sup>3</sup> /hr	— 782	598 782	648 848
CS76 XT, CS78B, CS79B	213.4	84	15.2	12	4	m <sup>3</sup> /hr yds <sup>3</sup> /hr	— 1174	896 1174	972 1272
CP44, CP44B	167.6	66	15.2	6	6	m <sup>3</sup> /hr yds <sup>3</sup> /hr	159 209	199 261	249 326
CP533E, CP54, CP56, CP54B, CP56B	213.4	84	30.5	12	6	m <sup>3</sup> /hr yds <sup>3</sup> /hr	478 626	478 626	647 847
CP76, CP68B, CP74B	213.4	84	30.5	12	6	m <sup>3</sup> /hr yds <sup>3</sup> /hr	— 782	598 782	648 848

Travel Speed Efficiency

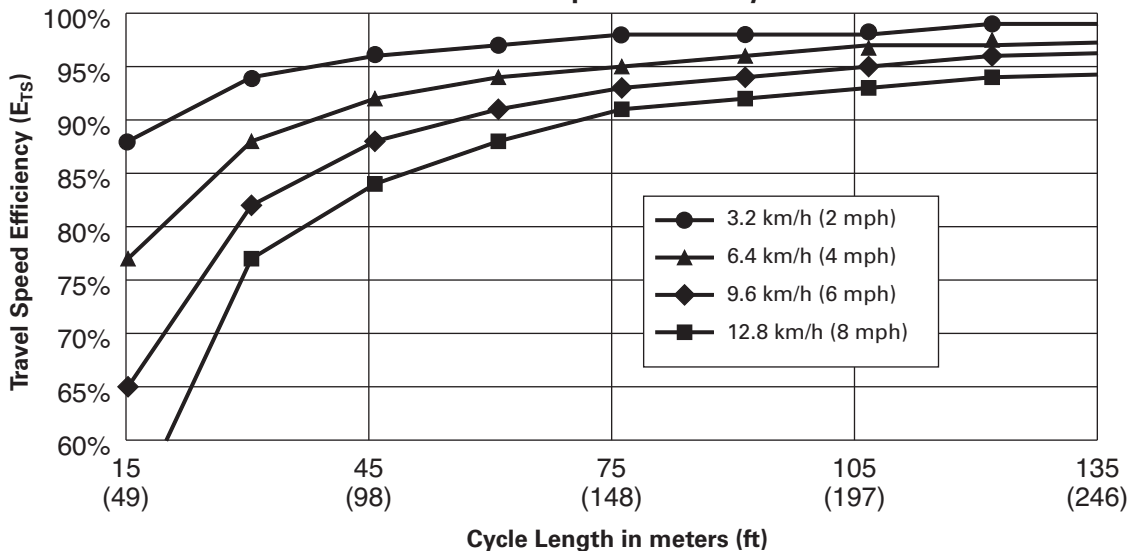

**Adjusting the Production Estimate**

If the assumed conditions are not close to the actual construction conditions, the production estimates should be corrected. The production estimate from the table can be adjusted for ‘actual’ construction conditions by applying adjustment factors:

$$Q \text{ (actual)} = Q \text{ (assumed)} \times F_s \times F_t \times F_p$$

- Where: Q (actual) = adjusted productivity
- Q (assumed) = productivity from table based on assumed conditions
- F<sub>s</sub> = adjustment for machine speed
- F<sub>t</sub> = adjustment for layer thickness
- F<sub>p</sub> = adjustment for no. of passes

The adjustment factors are determined by comparing the ‘actual’ conditions to the ‘assumed’ ones:

- F<sub>s</sub> = actual speed/assumed speed
- F<sub>t</sub> = actual thickness/assumed thickness
- F<sub>p</sub> = assumed passes/actual passes

Metric example

*Actual Conditions* — An 9.15-meter (full road width) base aggregate job is being completed with a compacted thickness of 15 cm. A CS44B is being used, operating at 4.0 km/h, and making 6 passes to achieve the desired compaction. The roller is overlapping its passes 6 inches.

For a 9.15-meter road base the table gives a CS44B productivity of 249 m<sup>3</sup>/hr. Since the speed, thickness, and passes are *different* from the assumed conditions, we should adjust this estimate:

	Assumed	Actual
<b>Speed</b>	6.4 km/h	4.0 km/h
<b>Thickness</b>	10.2 cm	15 cm
<b>Passes</b>	4 passes	6 passes

$$F_s = 4.0 \text{ km/h}/6.4 \text{ km/h} = 0.6$$

$$F_t = 15 \text{ cm}/10.2 \text{ cm} = 1.5$$

$$F_p = 4 \text{ passes}/6 \text{ passes} = 0.7$$

The estimated production is adjusted using these factors:

$$Q \text{ (actual)} = 249 \text{ m}^3/\text{hr} \times 0.6 \times 1.7 \times 0.7$$

$$= 178 \text{ m}^3/\text{hr} \text{ (233 yds}^3/\text{hr)}$$

English example

*Actual Conditions* — An wide area commercial site development job is being compacted in lifts of 8 inches. A CP56B is being used, operating at 4.0 mph, and making 4 passes to achieve the target density.

First, the table gives a CP56B productivity of 847 yds<sup>3</sup>/hr. Since lift thickness and passes required are *different* from the assumed conditions, we should adjust this estimate:

	Assumed	Actual
<b>Speed</b>	4.0 mph	4.0 mph
<b>Thickness</b>	12 inches	8 inches
<b>Passes</b>	6 passes	4 passes

$$F_s = \text{no correction necessary}$$

$$F_t = 8 \text{ inches}/12 \text{ inches} = 0.7$$

$$F_p = 6 \text{ passes}/4 \text{ passes} = 1.5$$

The estimated production is adjusted using these factors:

$$Q \text{ (actual)} = 847 \text{ yds}^3/\text{hr} \times 0.7 \times 1.5$$

$$= 890 \text{ yds}^3/\text{hr} \text{ (680 m}^3/\text{hr)}$$

**Notes on Productivity:**

- For jobs that are relatively narrow, especially road construction jobs, it is important to understand that certain widths of construction will be more productive than others for a given compactor. A productive construction width will make the most use of each side by side pass required by the compactor in order to cover the width.
- Production estimates should be adjusted further if the length of the compaction cycles are shorter than 75 m (250 ft). Refer to the Travel Speed Efficiency chart to determine efficiency E<sub>TS</sub>. For example, a compactor traveling at 6.4 km/h (4 mph) operating at cycle lengths of 150 ft has an E<sub>TS</sub> of 0.91. Multiply Q (actual) by E<sub>TS</sub>.

The table in this section gives production estimates for the following assumed conditions:

Compacted Layer Thickness	51 mm	2 in
Maximum Vibratory Frequency*	—	—
Impacts Spacing	33 impacts/m	10 impacts/ft
Passes per Machine Width	2	2
Compacted Material Density	2483 kg/m <sup>3</sup>	155 lb/ft <sup>3</sup>
Overlap of Rolling Width	152 mm	6 in
Overhang at Lane Edge	76 mm	3 in
Efficiency	75%	

\*Maximum vibratory frequency varies by machine, refer to table.

Table values give **representative** production rates for common construction widths. If the actual width falls between two assumed widths, use the higher number to estimate production. Minor adjustments can normally be made in the rolling method to reach this higher production: reduce overlap or overhang, increase speed, or increase the cycle time.

Model	Vibration Frequency	Units	PAVING WIDTH						
			1.8 m 6 ft	2.4 m 8 ft	3.0 m 10 ft	3.7 m 12 ft	4.3 m 14 ft	4.9 m 16 ft	5.5 m 18 ft
CB14B	53.3 Hz	Tonnes/hr	144.6	150.0	153.4	155.8	—	—	—
	<b>3200 vpm</b>	<b>tons/hr</b>	<b>159.4</b>	<b>165.3</b>	<b>169.1</b>	<b>171.7</b>	—	—	—
CB14B XW (1000 mm/39")	53.3 Hz	Tonnes/hr	144.6	192.9	187.5	184.1	—	—	—
	<b>3200 vpm</b>	<b>tons/hr</b>	<b>159.4</b>	<b>212.6</b>	<b>206.7</b>	<b>202.9</b>	—	—	—
CB22B	63 Hz	Tonnes/hr	170.8	227.8	221.4	217.5	214.6	245.3	239.2
	<b>3780 vpm</b>	<b>tons/hr</b>	<b>188.3</b>	<b>251.1</b>	<b>244.1</b>	<b>239.7</b>	<b>236.6</b>	<b>270.4</b>	<b>263.7</b>
CB24B, CB24B XT, and CC24B	63 Hz	Tonnes/hr	239.2	227.8	284.8	265.8	253.6	289.9	276.0
	<b>3780 vpm</b>	<b>tons/hr</b>	<b>263.7</b>	<b>251.1</b>	<b>313.9</b>	<b>293.0</b>	<b>279.6</b>	<b>319.6</b>	<b>304.2</b>
CB32B	63 Hz	Tonnes/hr	239.2	227.8	284.8	265.8	310.1	289.9	326.1
	<b>3780 vpm</b>	<b>tons/hr</b>	<b>263.7</b>	<b>251.1</b>	<b>313.9</b>	<b>293.0</b>	<b>341.8</b>	<b>319.6</b>	<b>359.5</b>
CB34B and CC34B	69 Hz	Tonnes/hr	262.0	249.5	311.9	291.1	339.6	317.5	357.2
	<b>4140 vpm</b>	<b>tons/hr</b>	<b>288.8</b>	<b>275.0</b>	<b>343.8</b>	<b>320.9</b>	<b>374.3</b>	<b>350.0</b>	<b>393.8</b>
CB36B	53 Hz	Tonnes/hr	201.2	268.3	239.6	287.5	260.8	298.1	274.4
	<b>3180 vpm</b>	<b>tons/hr</b>	<b>221.8</b>	<b>295.7</b>	<b>264.1</b>	<b>316.9</b>	<b>287.5</b>	<b>328.6</b>	<b>302.5</b>
CB44B	70 Hz	Tonnes/hr	265.8	354.3	316.4	379.7	344.5	393.7	362.4
	<b>4200 vpm</b>	<b>tons/hr</b>	<b>293.0</b>	<b>390.6</b>	<b>348.8</b>	<b>418.5</b>	<b>379.8</b>	<b>434.0</b>	<b>399.5</b>
CD44B	53 Hz	Tonnes/hr	201.2	268.3	239.6	287.5	260.8	298.1	274.4
	<b>3200 vpm</b>	<b>tons/hr</b>	<b>221.8</b>	<b>295.7</b>	<b>264.1</b>	<b>316.9</b>	<b>287.5</b>	<b>328.6</b>	<b>302.5</b>
CB46B	70 Hz	Tonnes/hr	265.8	354.3	443.0	379.7	442.9	393.7	442.9
	<b>4200 vpm</b>	<b>tons/hr</b>	<b>293.0</b>	<b>390.6</b>	<b>488.3</b>	<b>418.5</b>	<b>488.3</b>	<b>434.0</b>	<b>488.3</b>
CB54B	63.3 Hz	Tonnes/hr	240.5	320.6	400.8	343.5	400.8	356.3	400.8
	<b>3800 vpm</b>	<b>tons/hr</b>	<b>265.1</b>	<b>353.4</b>	<b>441.8</b>	<b>378.6</b>	<b>441.8</b>	<b>392.7</b>	<b>441.8</b>
CB64B	63.3 Hz	Tonnes/hr	400.8	320.6	400.8	480.9	400.8	458.0	515.3
	<b>3800 vpm</b>	<b>tons/hr</b>	<b>441.8</b>	<b>353.4</b>	<b>441.8</b>	<b>530.1</b>	<b>441.8</b>	<b>504.9</b>	<b>568.0</b>
CB66B, CB68B	63.3 Hz	Tonnes/hr	400.8	320.6	400.8	480.9	400.8	458.0	515.3
	<b>3800 vpm</b>	<b>tons/hr</b>	<b>441.8</b>	<b>353.4</b>	<b>441.8</b>	<b>530.1</b>	<b>441.8</b>	<b>504.9</b>	<b>568.0</b>
CD54B	63.3 Hz	Tonnes/hr	201.2	191.6	239.6	223.6	260.8	243.9	274.4
	<b>3800 vpm</b>	<b>tons/hr</b>	<b>221.8</b>	<b>211.2</b>	<b>264.1</b>	<b>246.5</b>	<b>287.5</b>	<b>268.9</b>	<b>302.5</b>

### Example

*Actual Conditions* — A 3.7 m (12 ft) lane is being paved with a compacted asphalt thickness of 10 cm (4 in). A CB54B is operating with a frequency of 42 Hz (2520 vpm) and 46 impacts per meter (14 impacts per ft) and making 4 passes to achieve target density. The roller is overlapping its passes 15 cm (6 in) and is overhanging the edges by 7.5 cm (3 in).

First, the table gives a CB54B productivity of 343 Tonnes/hr (378.6 tons/hr) for a 3.7 m (12 ft) paving width. Since the actual vibratory speed, thickness, impact spacing and passes are different from the assumed conditions, the estimate should be adjusted.

	Assumed	Actual
<b>Vibratory Speed</b>	63.3 Hz <b>3800 vpm</b>	42 Hz <b>2520 vpm</b>
<b>Impact Spacing</b>	33 impacts/m <b>10 impacts/ft</b>	46 impacts/m <b>14 impacts/ft</b>
<b>Thickness</b>	5 cm <b>2 in</b>	10 cm <b>4 in</b>
<b>Passes</b>	<b>2</b>	<b>4</b>

$$F_s = 42 \text{ Hz (2520 vpm)} / 63.3 \text{ Hz (3800 vpm)} = 0.66$$

$$F_i = 33 \text{ impacts/m (10 impacts/ft)} / 46 \text{ impacts/m (14 impacts/ft)} = 0.71$$

$$F_t = 10 \text{ cm (4 in)} / 5 \text{ cm (2 in)} = 2.0$$

$$F_p = 2 \text{ passes} / 4 \text{ passes} = 0.5$$

The actual, or adjusted, production estimate can then be determined from the following:

$$Q \text{ (actual)} = 343 \text{ Tonnes/hr (378.6 tons/hr)} \\ \times 0.66 \times 0.71 \times 2 \times 0.5 = \\ 161 \text{ Tonnes/hr (177.4 tons/hr)}$$

### Notes on Productivity:

- Higher speed usually results in lower density achieved per pass.
- Productivity on uphill slopes may be reduced.
- Tabulated production estimates assume that 1 pass is used for re-positioning the machine at the beginning of the next run.

The tables in this section give production estimates for the following assumed conditions:

	Hot Mix Asphalt		Soil and Aggregate		Cold In-Place Recycled Asphalt	
Compacted Layer Thickness	51 mm	<b>2 in</b>	152 mm	<b>6 in</b>	203 mm	<b>8 in</b>
Maximum Propelling Speed	8 km/h	<b>5 mph</b>	8 km/h	<b>5 mph</b>	4.8 km/h	<b>3 mph</b>
Passes per Machine Width	<b>4</b>		<b>4</b>		<b>6</b>	
Compacted Material Density	2486 kg/cm <sup>3</sup>	<b>155 lb/ft<sup>3</sup></b>	2085 kg/cm <sup>3</sup>	<b>130 lb/ft<sup>3</sup></b>	2246 kg/cm <sup>3</sup>	<b>140 lb/ft<sup>3</sup></b>
Overlap of Rolling Width	152 mm	<b>6 in</b>	152 mm	<b>6 in</b>	152 mm	<b>6 in</b>
Overhang at Lane Edge	76 mm	<b>3 in</b>	76 mm	<b>3 in</b>	76 mm	<b>3 in</b>
Cycle Time (2 passes)	<b>120 seconds</b>		<b>120 seconds</b>		<b>120 seconds</b>	

Table values give **representative** production rates for common construction widths. If the actual width falls between two assumed widths, use the higher number to estimate production. Minor adjustments can normally be made in the rolling method to reach this higher production: reduce overlap or overhang, increase speed, or increase the cycle time.

<b>Hot Mix Asphalt</b>		<b>PAVING WIDTH</b>						
		1.8 m <b>6 ft</b>	2.4 m <b>8 ft</b>	3.0 m <b>10 ft</b>	3.7 m <b>12 ft</b>	4.3 m <b>14 ft</b>	4.9 m <b>16 ft</b>	5.5 m <b>18 ft</b>
<b>Model</b>	<b>Units</b>							
CW14, CW16	Tonnes/hr <b>tons/hr</b>	195.2 <b>215.1</b>	260.2 <b>286.8</b>	325.3 <b>358.6</b>	270.2 <b>297.9</b>	315.3 <b>347.5</b>	275.5 <b>303.7</b>	310.0 <b>341.7</b>
CW34	Tonnes/hr <b>tons/hr</b>	323.2 <b>356.2</b>	239.4 <b>263.9</b>	299.3 <b>329.9</b>	359.1 <b>395.9</b>	419.0 <b>461.8</b>	331.5 <b>365.4</b>	372.9 <b>411.1</b>
PS360C	Tonnes/hr <b>tons/hr</b>	351.3 <b>387.2</b>	260.2 <b>286.8</b>	325.3 <b>358.6</b>	390.3 <b>430.3</b>	455.4 <b>502.0</b>	360.3 <b>397.2</b>	405.3 <b>446.8</b>

<b>Soil and Aggregate</b>		1.8 m <b>6 ft</b>	2.4 m <b>8 ft</b>	3.0 m <b>10 ft</b>	3.7 m <b>12 ft</b>	4.3 m <b>14 ft</b>	4.9 m <b>16 ft</b>	5.5 m <b>18 ft</b>
CW14, CW16	Tonnes/hr <b>tons/hr</b>	490.1 <b>540.2</b>	653.4 <b>720.3</b>	816.8 <b>900.4</b>	678.6 <b>748.0</b>	791.7 <b>872.7</b>	691.9 <b>762.7</b>	778.4 <b>858.0</b>
CW34	Tonnes/hr <b>tons/hr</b>	811.6 <b>894.6</b>	601.1 <b>662.7</b>	751.5 <b>828.4</b>	901.8 <b>994.0</b>	1052.1 <b>1159.7</b>	832.4 <b>917.5</b>	936.5 <b>1032.3</b>
PS360C	Tonnes/hr <b>tons/hr</b>	882.2 <b>972.4</b>	653.4 <b>720.3</b>	816.8 <b>900.4</b>	980.2 <b>1080.4</b>	1143.5 <b>1260.5</b>	904.8 <b>997.3</b>	1017.9 <b>1122.0</b>

<b>Cold In-Place Recycled Asphalt</b>		1.8 m <b>6 ft</b>	2.4 m <b>8 ft</b>	3.0 m <b>10 ft</b>	3.7 m <b>12 ft</b>	4.3 m <b>14 ft</b>	4.9 m <b>16 ft</b>	5.5 m <b>18 ft</b>
CW14, CW16	Tonnes/hr <b>tons/hr</b>	288.0 <b>317.5</b>	384.0 <b>423.3</b>	480.0 <b>529.2</b>	394.1 <b>434.5</b>	459.8 <b>506.9</b>	399.4 <b>440.3</b>	449.3 <b>495.3</b>
CW34	Tonnes/hr <b>tons/hr</b>	492.1 <b>542.4</b>	353.3 <b>389.5</b>	441.6 <b>486.9</b>	530.0 <b>584.2</b>	618.3 <b>681.5</b>	483.5 <b>533.0</b>	543.9 <b>600.0</b>
PS360C	Tonnes/hr <b>tons/hr</b>	534.9 <b>589.6</b>	384.0 <b>423.3</b>	480.0 <b>529.2</b>	576.1 <b>635.0</b>	672.1 <b>740.8</b>	525.5 <b>579.3</b>	591.2 <b>651.7</b>



Example

*Actual Conditions* — A 7.3 m (23'11") (full road width) base aggregate job is being completed with a compacted thickness of 200 mm (8 in). A CW14 is being used, operating at 6.5 km/h (4 mph), and making 6 passes achieve the desired compaction. The roller is overlapping its passes 152 mm (6 in).

First, the table does not show production for 7.3 m (23'11") so use the greatest width on the table: 5.5 m (18'1"). The table gives a CW14 productivity of 778.4 Tonnes/hr (858.0 tons/hr) for this paving width. We can expect that the actual productivity for 7.3 m (23'11") will be slightly higher than that. Since the speed, thickness, and passes are *different* from the assumed conditions, we should adjust this estimate:

	Assumed		Actual	
<b>Speed</b>	8 km/h	<b>5 mph</b>	6.5 km/h	<b>4 mph</b>
<b>Thickness</b>	152 mm	<b>6 in</b>	200 mm	<b>8 in</b>
<b>Passes</b>	<b>4</b>		<b>6</b>	

$$F_s = 6.5 \text{ km/h} / 8 \text{ km/h} (4 \text{ mph} / 5 \text{ mph}) = 0.8$$

$$F_t = 200 \text{ mm} / 152 \text{ mm} (8 \text{ in} / 6 \text{ in}) = 1.3$$

$$F_p = 4 \text{ passes} / 6 \text{ passes} = 0.7$$

The estimated production is adjusted using these factors:

$$Q (\text{actual}) = 778.4 \text{ Tonnes/hr} (858.0 \text{ tons/hr}) \times 0.8 \times 1.3 \times 0.7 = 567 \text{ Tonnes/hr} (625 \text{ ton/hr})$$

**Notes on Productivity:**

- Ballast weight and tire pressure can significantly affect performance of a pneumatic tire compactor. Refer to machine specifications to choose the best configuration.
- Productivity on uphill grades and very thick layers (>127 mm, or 5 in) may be reduced due to a necessary reduction in speed.
- The 11-tire configuration for the CW14 is designed only for chip-and-seal applications. It is not recommended in other applications.

# PIPELAYERS

## CONTENTS

Features . . . . .	14-1
Specifications . . . . .	14-2
Lifting Capacities . . . . .	14-4
Drawbar Pull Charts . . . . .	14-7
Travel and Hook Speeds . . . . .	14-9
Application . . . . .	14-10
Extreme Slope Operation . . . . .	14-12

## Features:

- **Hydrostatic transmission** on PL61.
- **Planetary power shift** transmission on PL72, PL83 and PL87 models.
- **Kick-out helps prevent boom bending** as boom approaches near-vertical.
- **Sealed and Lubricated Track.**
- **Simplified Controls** for all functions including raise, lower, quick-drop and power down, variable range and speed adjustments.
- **Modular design of major components and accessory drive system** for simplified repair.
- **Separate, self-energizing brakes** for boom and hook winches.
- **Positive** track pin retention (PL83 and PL87).
- **Hydraulic Drawworks** with two independently driven hydraulic motors for boom and hook winches.

MODEL	PL61		PL72		
Flywheel Power	92 kW	125 hp	183 kW	246 hp	
Operating Weight (with full fuel tank and operator)	17 000 kg	37,480 lb	31 278 kg	68,945 lb	
Engine Model	C6.6 ACERT™		C9.3 ACERT		
Rated Engine RPM	2100		2000		
No. of Cylinders	6		6		
Displacement	6.6 L	403 in <sup>3</sup>	9.3 L	5675 in <sup>3</sup>	
Lift Capacity at 1.22 m (4'0") Overhang	18 145 kg	40,000 lb	40 823 kg	90,000 lb	
Standard Boom Length	5.49 m	18'0"	6.1 m	20'0"	
Width of Standard Shoe	560 mm	22"	760 mm	30"	
Length of Track on Ground	2645 mm	8'8"	3.71 m	12'2"	
Ground Contact Area (with standard shoes)	3 m <sup>2</sup>	4650 in <sup>2</sup>	5.42 m <sup>2</sup>	8406 in <sup>2</sup>	
Track Gauge	2 m	6'7"	2.29 m	7'6"	
Fuel Tank Refill Capacity	295 L	78 U.S. gal	415 L	109.6 U.S. gal	
GENERAL DIMENSIONS:					
Height to Top of Stack	2.91 m	9'7"	3.21 m	10'6"	
Height to Top of Counterweight	2.45 m	8'1"	2.60 m	8'6"	
Height with ROPS (boom removed)	2958 mm	9'8.5"	3.43 m	11'3"	
Width, Weights Retracted	3 m	9'10"	3.67 m	12'1"	
Minimum Shipping Width (both side frames removed)	2560 mm	8'5"	3.62 m	11'11"	
Shipping Width	2816 mm*	9'3"*	3.77 m	12'4"	
Overall Length	3.78 m	12'5"	4.78 m	15'8"	
Ground Clearance	360 mm	14"	0.43 m	1'5"	
DRUMS and CABLES:					
Drum Capacity	Load	73 m	239'	52 m	170'
	Boom	49.4 m	162'	52 m	170'
Cable Diameter	Load	16 mm	0.62"	19 mm	0.75"
	Boom	16 mm	0.62"	19 mm	0.75"
Drum Diameter	Load	216 mm	8.5"	216 mm	8.5"
	Boom	245 mm	9.63"	216 mm	8.5"
Adjustable Counterweights		7 @		10 @	
	67.7 kg ea	149 lb ea	393 kg ea	865 lb ea	
		9 @			
	114.8 kg ea	253 lb ea			
Total Weight Extendable	1231 kg	2714 lb	8540 kg	18,827 lb	
	LGP Option				
Operating Weight 610 mm (24")	17 800 kg	39,242 lb			
Shipping Width:					
Boom Removed	3200 mm	10'6"			
Counterweight Removed	3116 mm	10'3"			
Frame, Brackets, Winches Removed	2760 mm	9'1"			
Track Shoe Width	610 mm	24"			
	760 mm	30"			
Ground Contact Area:					
610 mm (24") Shoes	3.2 m <sup>2</sup>	4690 in <sup>2</sup>			
760 mm (30") Shoes	4 m <sup>2</sup>	6200 in <sup>2</sup>			

\*Shipping width (left frame removed).

<b>MODEL</b>	<b>PL83</b>		<b>PL87</b>		
Flywheel Power	258 kW	<b>345 hp</b>	259 kW	<b>346 hp</b>	
Operating Weight (with full fuel tank and operator)	50 492 kg	<b>111,316 lb</b>	55 246 kg	<b>121,795 lb</b>	
Engine Model	<b>C15 ACERT</b>		<b>C15 ACERT</b>		
Rated Engine RPM	<b>1900</b>		<b>1900</b>		
No. of Cylinders	<b>6</b>		<b>6</b>		
Displacement	15.2 L	<b>928 in<sup>3</sup></b>	15.2 L	<b>928 in<sup>3</sup></b>	
Lift Capacity at 1.22 m (4'0") Overhang	77 111 kg	<b>170,000 lb</b>	97 976 kg	<b>216,000 lb</b>	
Standard Boom Length	7.3 m	<b>24'0"</b>	7.3 m	<b>24'0"</b>	
Width of Standard Shoe	760 mm	<b>30"</b>	864 mm	<b>34"</b>	
Length of Track on Ground	3715 mm	<b>12'2"</b>	3715 mm	<b>12'2"</b>	
Ground Contact Area (with standard shoes)	5.3 m <sup>2</sup>	<b>8215 in<sup>2</sup></b>	6.4 m <sup>2</sup>	<b>9920 in<sup>2</sup></b>	
Track Gauge	2.34 m	<b>7'8"</b>	2.54 m	<b>8'4"</b>	
Fuel Tank Refill Capacity	415 L	<b>109.6 U.S. gal</b>	415 L	<b>109.6 U.S. gal</b>	
<b>GENERAL DIMENSIONS:</b>					
Height to Top of Stack	3.49 m	<b>11'5"</b>	3.49 m	<b>11'5"</b>	
Height to Top of Counterweight	3.4 m	<b>11'2"</b>	3.4 m	<b>11'2"</b>	
Height with ROPS (boom removed)	3.53 m	<b>11'7"</b>	3.53 m	<b>11'7"</b>	
Width, Weights Retracted	4.11 m	<b>13'6"</b>	4.32 m	<b>14'2"</b>	
Minimum Shipping Width (both side frames removed)	3.86 m	<b>12'8"</b>	4.06 m	<b>13'4"</b>	
Shipping Width	3.77 m	<b>13'4"</b>	4.26 m	<b>14'0"</b>	
Overall Length	5.45 m	<b>17'11"</b>	5.45 m	<b>17'11"</b>	
Ground Clearance	0.47 m	<b>1'7"</b>	0.47 m	<b>1'7"</b>	
<b>DRUMS and CABLES:</b>					
Drum Capacity	Load	129 m	<b>425'</b>	129 m	<b>425'</b>
	Boom	129 m	<b>425'</b>	129 m	<b>425'</b>
Cable Diameter	Load	19 mm	<b>0.75"</b>	19 mm	<b>0.75"</b>
	Boom	19 mm	<b>0.75"</b>	19 mm	<b>0.75"</b>
Drum Diameter	Load	254 mm	<b>10"</b>	254 mm	<b>10"</b>
	Boom	254 mm	<b>10"</b>	254 mm	<b>10"</b>
Adjustable Counterweights		<b>12 @</b>		<b>14 @</b>	
Total Weight Extendable		735 kg ea	<b>1617 lb ea</b>	795 kg ea	<b>1749 lb ea</b>
		10 688 kg	<b>25,563 lb</b>	12 911 kg	<b>28,463 lb</b>

**PL61**

**LIFTING CAPACITY\* 5.49 m (18'0") BOOM**

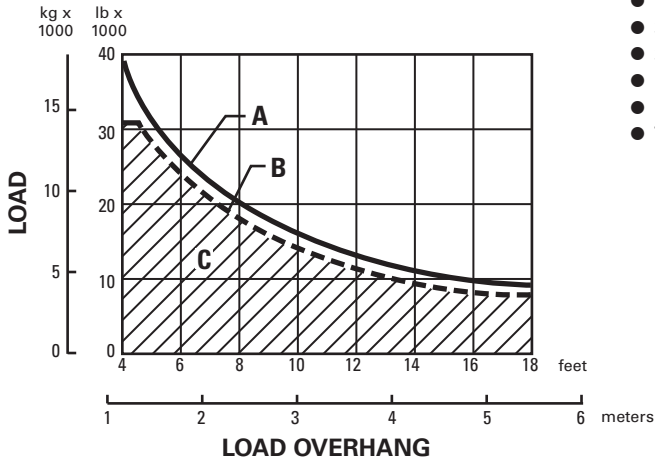

**\*Specified Equipment:**

- 16 mm (5/8") diameter wire rope.
- 183.3 kN (41,200 lb) minimum breaking strength.
- 3 part load line.
- 3 part boom line.
- 1231 kg (2714 lb) counterweight extended.
- Standard 5.49 m (18'0") Boom.
- Total operating weight
  - Narrow — 17 000 kg (37,480 lb).
  - LGP — 17 800 kg (39,242).

**KEY**

- A — Lift capacity at tipping point per ISO 8813
- B — Rated load capacity per ANSI/ASME B30.14
- C — Working range per ANSI/ASME B30.14

**PL72**

**LIFTING CAPACITY\* 6.1 m or 7.3 m (20'0" or 24'0") BOOMS**

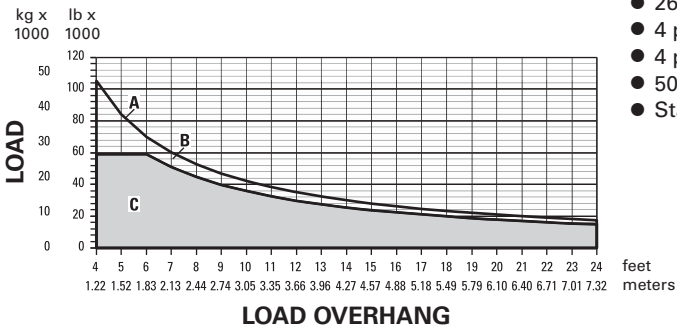

**\*Specified Equipment:**

- 19 mm (3/4") diameter wire rope.
- 261.66 kN (58,800 lb) minimum breaking strength.
- 4 part load line.
- 4 part boom line.
- 5073 kg (11,184 lb) counterweight extended.
- Standard 6.1 m (20'0") Boom.

**KEY**

- A — Lift capacity at tipping point\*
- B — Rated load capacity\*
- C — Working range\*

\*Per ISO 8813:1992.

**NOTE:** ISO stands for the International Standards Organization. ANSI stands for American National Standard Institute.

**PL83**

**LIFTING CAPACITY\* 7.3 m, 8.5 m (24'0", 28'0") BOOMS**

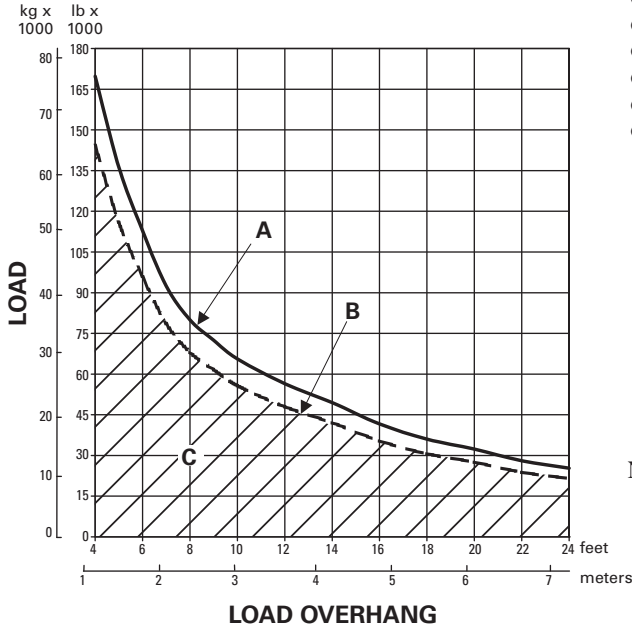

**\*Specified Equipment:**

- 19 mm (3/4") diameter wire rope.
- 26 672 kg (58,800 lb) minimum breaking strength.
- 6 part load line.
- 5 part boom line.
- 10 826 kg (23,817 lb) counterweight extended.
- Standard 7.3 m (24'0") Boom.
- Total operating weight 48 444 kg (106,800 lb).

**KEY**

- A – Max lift capacity per ISO 8813
- B – Rated load per ANSI/ASME B30.14
- C – Working range per ANSI/ASME B30.14

**NOTE:** ISO stands for the International Standards Organization. ANSI stands for American National Standard Institute.

**PL87**

**LIFTING CAPACITY\* 8.5 m (28'0") BOOM**

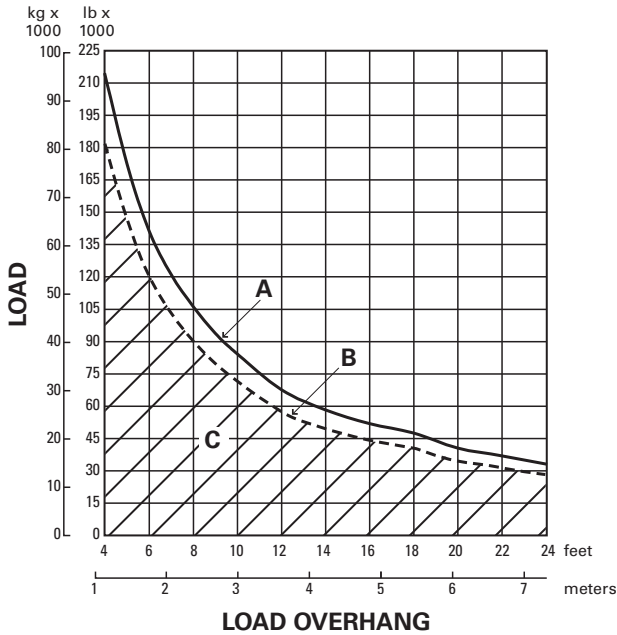

**\*Specified Equipment:**

- Load: 19 mm (3/4") dia. wire rope 26 672 kg (58,800 lb) minimum breaking strength.
- Boom: 19 mm (3/4") dia. wire rope 26 672 kg (58,800 lb) minimum breaking strength.
- 8 part load line.
- 5 part boom line.
- 13 903 kg (30,587 lb) counterweight extended.
- Standard 7.3 m (24'0") Boom.
- Total operating weight 54 485 kg (120,123 lb).

**KEY**

- A — Max lift
- B — Rated lift
- C — Working range per ANSI/ASME B30.14

**NOTE:** ISO stands for the International Standards Organization. ANSI stands for American National Standard Institute.

**PL61**

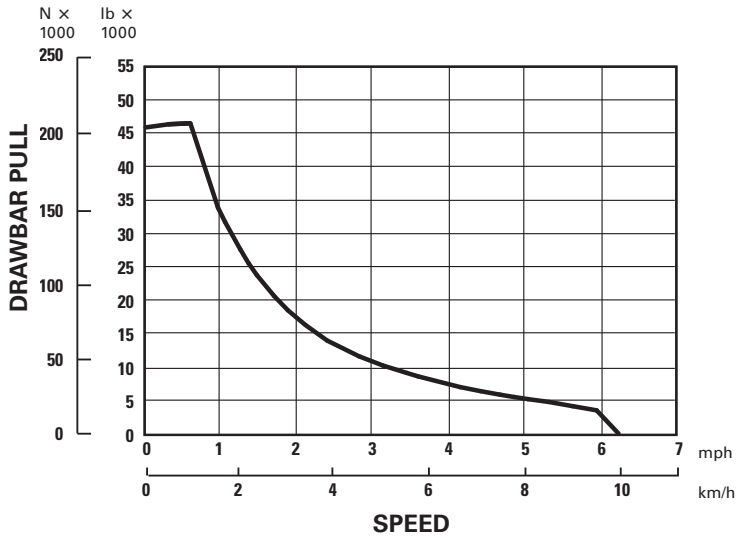

**NOTE:** Usable pull will depend upon weight and traction of equipped tractor.

**PL72**

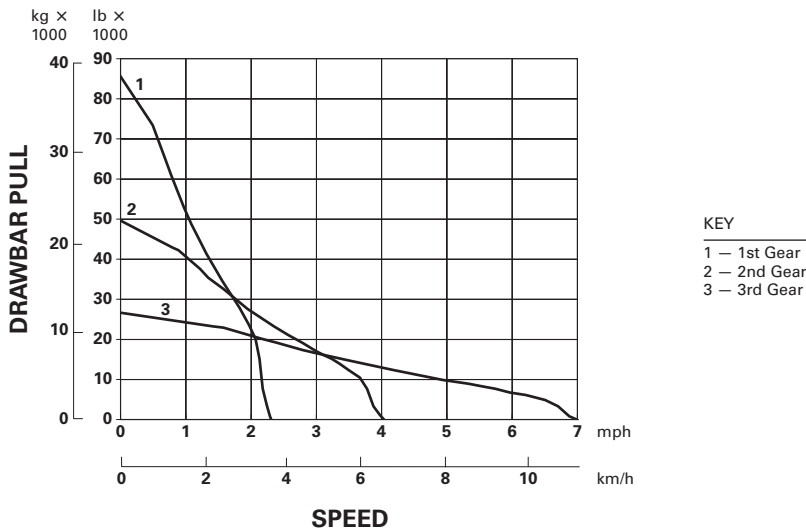

**KEY**  
 1 — 1st Gear  
 2 — 2nd Gear  
 3 — 3rd Gear



**PL83**

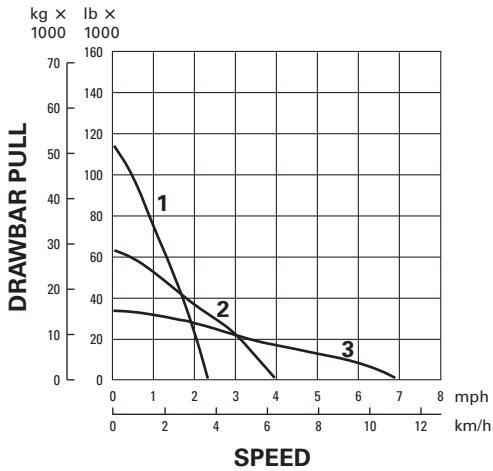

**KEY**  
 1 — 1st Gear  
 2 — 2nd Gear  
 3 — 3rd Gear

**PL87**

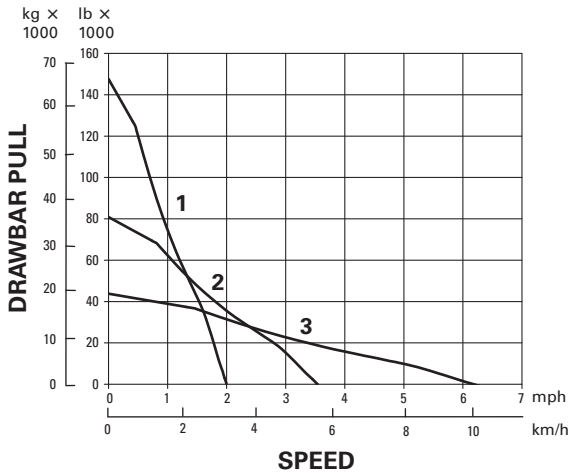

**KEY**  
 1 — 1st Gear  
 2 — 2nd Gear  
 3 — 3rd Gear

MODEL	PL61				PL72			
	Forward		Reverse		Forward		Reverse	
Travel	km/h	mph	km/h	mph	km/h	mph	km/h	mph
<b>Speeds (at rated RPM)</b>								
1st Gear .....	3.1	1.9	3.8	2.3	3.8	2.3	4.8	3.0
2nd Gear .....	5.4	3.3	6.7	4.1	6.6	4.1	8.4	5.2
3rd Gear .....	10.0	6.2	10.0	6.2	11.4	7.1	14.6	9.0
Hydrostatic .....	10.0	6.2	10.0	6.2	—		—	

MODEL	PL83				PL87			
	Forward		Reverse		Forward		Reverse	
Travel	km/h	mph	km/h	mph	km/h	mph	km/h	mph
<b>Speeds (at rated RPM)</b>								
1st Gear .....	3.4	2.1	4.5	2.8	3.4	2.1	4.5	2.8
2nd Gear .....	6.1	3.8	8.0	5.0	6.1	3.8	8.0	5.0
3rd Gear .....	10.6	6.6	14.2	8.8	10.6	6.6	14.2	8.8

MODEL	PL61		PL72	
	m/min	ft/min	m/min	ft/min
Pipelayer Hook Speeds per minute, Bare drum at rated engine RPM				
Low Raise & Lower .....	33.0	108	15.9	60.9
Hi Raise & Lower .....	69.5	228	44.0	144.4

MODEL	PL83		PL87	
	m/min	ft/min	m/min	ft/min
Pipelayer Hook Speeds per minute, Bare drum at rated engine RPM				
Low Raise & Lower .....	15.5	50.8	15.5	50.8
Hi Raise & Lower .....	22.0	72.0	15.5	50.8

**PIPELAYER APPLICATION CALCULATIONS:**

**Typical pipelayer applications on flat, firm underfoot conditions**

- PL61** laying 8" to 16" pipe
- PL72** laying 16" to 24" pipe
- PL83** laying 24" to 36" pipe
- PL87** laying 36" to 56" pipe

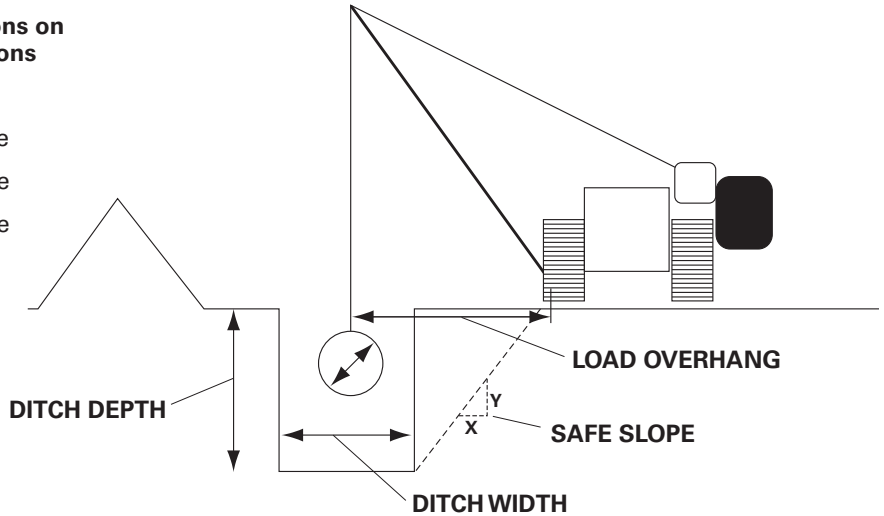

The chart above provides general information representing typical pipelayer applications. While the following scenario explores many of the variables involved in pipelaying it does not cover all the possible variables that must be considered by pipelaying contractors.

When sizing pipelayers for an application there are many considerations other than the machine's SAE rated lift capacity. These include but are not limited to:

- pipe diameter and weight per linear foot
- ditch width and depth
  - ditch width is typically  $2 \times$  pipe diameter
  - ditch depth is typically  $>2.5 \times$  pipe diameter
- distance from the ditch (safe slope) required by soil stability conditions
  - varies by local ground conditions but typically 2:1 (meaning the pipelayer must be  $2 \times$  ditch depth from the ditch edge)

- acceptable distance between pipe lifting points while suspended (to prevent bending)
  - determined by the pipe's bending characteristics.
  - If the lifting points are too far apart a pipe can sag enough due to its own weight that it will damage itself.
- the operating safety factor desired by the contractor
- the length of pipe that will need to be suspended while laying-in
  - determined by pipe bending characteristics, terrain, etc.
- ground conditions, road bed preparation

An important consideration is the necessary load overhang. This is the distance from the center of the pipe to the tractor's left track rail. The load overhang required for an application can be estimated by:

- load overhang = safe slope × ditch depth + (0.5 × ditch width)

The pipelayer's rated load capacity at a specific load overhang (per ANSI/ASME B30.14) can be found in the load capacity graphs in this section of the performance handbook. Once the load capacity is determined the maximum lift point spacing can be estimated by:

- max lift point spacing =  $\frac{\text{load capacity at load overhang}}{\text{safety factor} \times \text{pipe weight per linear foot}}$

The maximum distance between pipe lift points (based on pipe bending characteristics) may be a shorter distance than the maximum spacing between lift points as calculated based on pipelayer load capacity. If this is the case, then in order to avoid damaging the pipe, the shorter distance should be considered to be the maximum distance between pipelayers.

As an example, consider a project involving 0.5" wall 24" diameter pipe which has a weight per linear foot of 125.5 lb and the soil has a safe slope of 2. Using the above formulas:

- the ditch depth would be 3 × 2 ft = 6 ft deep
- the ditch width would be 2 × 2 ft = 4 ft
- the load overhang would be 2 × 6 ft + (0.5 × 4 ft) = 14 ft

Using the PL72's lift capacity chart we find that the PL72 has an ANSI rated load capacity of approximately 21,250 lb at a 14 ft load overhang.

When using rated load numbers it is important to understand that the lift capacity charts are based on SAE and ANSI test procedures that rate pipelayers on level, concrete surfaces. Working on softer underfoot conditions, working on slopes, (and other) can greatly reduce the pipelayer's load capacity.

If the contractor employs a safety factor of 2 then the maximum spacing between pipe lift points is:

$$\frac{21,250 \text{ lb}}{2 \times 125.5 \text{ lb/ft}} = 84.7 \text{ ft}$$

It is important to remember that this is the distance between the lift points, not the distance nose-to-tail between pipelayers. For this example, assume that 500 ft of pipe must be suspended during the laying-in process.

$$\frac{500 \text{ ft}}{84.7 \text{ ft per pipelayer}} = 5.9 \text{ which means that six pipelayers are needed}$$

The number of pipelayers required could also be determined by a second method:

$$\frac{\text{ft of pipe suspended} \times \text{pipe weight per ft} \times \text{safety factor}}{\text{rated load at overhang}}$$

In this case:

$$\frac{500 \text{ ft} \times 125.5 \text{ lb/ft} \times 2}{21,250 \text{ lb}} = 5.9 \text{ which again implies six pipelayers}$$

If, in this same example, soil conditions required a safe slope of 2.33 then the load overhang would have been 16 ft. At this load overhang the 90,000 lb lift pipelayer's rated load capacity is approximately 18,125 lb. Using the equations above, this results in 72.2 ft between lift points which means that seven 90,000 lb lift pipelayers are now necessary. Using the second method:

$$\frac{500 \text{ ft} \times 125.5 \text{ lb/ft} \times 2}{18,125 \text{ lb}} = 6.9 \text{ again implying that seven 90,000 lb lift pipelayers are needed}$$

Rather than adding another pipelayer, PL83's could be used. At a 16 ft load overhang the PL83 has a rated load capacity of 29,400 lb. This translates to 117.1 ft between lift points. If the pipe's bending characteristics will allow this space between lift points, the job could be done with only five PL83's.

## EXTREME SLOPE OPERATION

The maximum fore and aft grade in static condition on which each track-type tractor or pipelayer will maintain proper lubrication is 45 degrees (100%). Consult Operation & Maintenance Manual (if applicable) for POWER TRAIN fluid level overfill requirements for operation on extreme slopes. Extreme slope operation is anytime the slope exceeds 25° (47%).

When working sidehills and slopes, consideration should be given to the following important points:

- Speed of travel — At higher speeds, inertia forces tend to make the tractor less stable.
- Roughness of terrain or surface — Ample allowance should be made where the terrain or surface is uneven.
- Mounted equipment — Bulldozers, sidebooms, winches, and other mounted equipment cause the tractor to balance differently.
- Nature of surface — New earthen fills may give way with the weight of the tractor. Rocky surfaces may promote side slipping of tractor.
- Track slippage due to excessive loads — This may cause downhill track to “dig in,” increasing angle of tractor.

The ENGINE should never be overfilled with oil. This may lead to rapid overheating. For extreme slope operation, engine oil should be maintained at the full mark.

**NOTE:** Both ENGINE and POWER TRAIN fluid levels should be checked on level ground before working sidehills and slopes.

- Implements hitched to the drawbar — This may decrease weight on uphill track, e.g., logging arch, two-wheel wagon.
- Height of hitch on tractor — When a high drawbar is used the tractor is less stable than with the standard drawbar.
- Width of shoes — Wide track shoes tend to decrease “digging in”, hence tractor is more stable.
- Operated equipment — Be aware of the stability and other performance features of the equipment operated by the tractor.
- Keep all attachments or pulled loads low to the ground for optimum stability.

**NOTE:** Safe operation on steep slopes may require special machine maintenance as well as excellent operator skill and proper equipment for the specific application. Consult Operation & Maintenance Manual (if applicable) for proper fluid level requirements.

# SKID STEER LOADERS MULTITERRAIN LOADERS COMPACT TRACK LOADERS

## CONTENTS

### SKID STEER LOADERS/ MULTITERRAIN LOADERS/ COMPACT TRACK LOADERS

Features . . . . .	15-2	Work Tools:	
SSL Specifications . . . . .	15-3	Augers . . . . .	15-105
SSL Performance Data . . . . .	15-7	Brushcutters . . . . .	15-108
SSL Dimensions . . . . .	15-40	Cold Planers . . . . .	15-110
SSL Work Tool Compatibility . . . . .	15-44	Landscape Tillers . . . . .	15-115
MTL Specifications . . . . .	15-47	Landscape Rakes . . . . .	15-117
MTL Performance Data . . . . .	15-49	Mulchers . . . . .	15-119
MTL Dimensions . . . . .	15-64	Power Box Rakes . . . . .	15-121
MTL Work Tool Compatibility . . . . .	15-66	Trenchers . . . . .	15-123
CTL Specifications . . . . .	15-69	Vibratory Compactors . . . . .	15-126
CTL Performance Data . . . . .	15-72	Brooms . . . . .	15-128
CTL Dimensions . . . . .	15-99	Stump Grinders . . . . .	15-131
CTL Work Tool Compatibility . . . . .	15-102	Angle Blades . . . . .	15-134
		Backhoes . . . . .	15-135
		Material Handling Arm . . . . .	15-136
		Snow Blowers . . . . .	15-137
		Wheel Saws . . . . .	15-138

**Features:**

- **The standard demand cooling fan** provides improved fuel efficiency and increased horsepower.
- **Industry leading sealed and pressurized cab option** provides a cleaner and quieter operating environment with excellent Work Tool visibility on D and D2 Series machines.
- **Ergonomically designed cab** provides maximum operator comfort and visibility.
- **Low-effort joystick controls, armrest and retractable seat belt** for easy operation.
- **Available high-back, heated, air ride seat with seat mounted adjustable joystick controls** make the D and D2 Series machines the industry leaders in operator comfort.
- **Deep skid resistant steps** and two tilt cylinders makes egress/ingress easy.
- **Hand and foot throttle** for continuous or variable engine speed.
- **Anti-stall feature (B3 Series) and Electronic Torque Management (D and D2 Series)** provide maximum rimpull and hydraulic power while lugging the engine.
- **High hydraulic horsepower** gets work done quickly.
- **Direct drive hystat pumps** eliminate drive belts.
- **Ground level access** to all daily service and routine maintenance points helps reduce machine downtime for greater productivity.
- **High performance power train** provides maximum performance and production capability on D and D2 Series machines through the Electronic Torque Management system, optional two speed travel and an electronic hand/foot throttle with decel pedal capability.
- **Cat® “Intelligent Leveling” system (ILEV)** provides industry leading technology, integration and optional features on D and D2 Series machines such as dual direction self level, work tool return to dig and work tool positioner.
- **Speed Sensitive Ride Control** option on D and D2 Series machines improves operation on rough terrain, enabling better load retention, increased productivity and greater operator comfort.
- **Maximize machine capability and control with optional Advanced Display** providing on-screen adjustment capability on D and D2 Series machines for implement response, hystat response, and creep control, multi-language functionality with customizable layouts, security system, and rearview camera.
- **High performance cooling systems and extended life coolant**, along with high performance engine and hydraulic oils, extend service intervals for low operating costs.
- **Deutsch electrical connectors** are color coded, numbered and protected with nylon braiding.
- **Electro-deposited** or “E” coat corrosion protection for long paint life.
- **High flow XPS hydraulics** are optional on most D Series models. The XHP hydraulic package option on the 272D2, 297D2 and 299D2 combines the high pressure of XPS with even higher flow for the most demanding hydromechanical work tool applications such as mulching, cold planing, and wheel saw cutting.
- **High flow hydraulics** on the 226B3, 226D, 232D, 236D, 239D, 242D, 249D, 257D, and 259D operate more demanding, rotating work tools such as brooms, cold planers, trenchers, landscape rakes, power rakes, tillers, snow blowers, brush cutters, and stump grinders.

<b>MODEL</b>	<b>216B3</b>		<b>226B3</b>	
Flywheel Power: Net	35 kW	<b>48 hp</b>	42 kW	<b>56 hp</b>
Gross	38 kW	<b>51 hp</b>	46 kW	<b>62 hp</b>
Engine Model	<b>C2.2</b>		<b>C2.2 T</b>	
Rated Engine RPM	<b>3000</b>		<b>3000</b>	
Bore	84 mm	<b>3.3"</b>	84 mm	<b>3.3"</b>
Stroke	100 mm	<b>3.9"</b>	100 mm	<b>3.9"</b>
Displacement	2.2 L	<b>134 in<sup>3</sup></b>	2.2 L	<b>134 in<sup>3</sup></b>
No. Cylinders	<b>4</b>		<b>4</b>	
One Speed Forward	0-12.7 km/h	<b>0-7.9 mph</b>	0-12.7 km/h	<b>0-7.9 mph</b>
One Speed Reverse	0-12.7 km/h	<b>0-7.9 mph</b>	0-12.7 km/h	<b>0-7.9 mph</b>
Hydraulic Cycle Time, Empty Bucket:	<b>Seconds</b>		<b>Seconds</b>	
Raise	<b>2.7</b>		<b>2.7</b>	
Dump	<b>2.1</b>		<b>2.1</b>	
Lower (Empty, Float Down)	<b>2.7</b>		<b>2.7</b>	
Total	<b>7.5</b>		<b>7.5</b>	
Tread Width	1244 mm	<b>4'1"</b>	1244 mm	<b>4'1"</b>
Width Over Tires	1525 mm	<b>5'0"</b>	1525 mm	<b>5'0"</b>
Ground Clearance	195 mm	<b>8.0"</b>	195 mm	<b>8.0"</b>
Fuel Tank Capacity	58 L	<b>15.4 U.S. gal</b>	58 L	<b>15.4 U.S. gal</b>
Hydraulic Tank Capacity	35 L	<b>9.2 U.S. gal</b>	35 L	<b>9.2 U.S. gal</b>
Hydraulic System Capacity (includes tank)	55 L	<b>14.5 U.S. gal</b>	55 L	<b>14.5 U.S. gal</b>
Hydraulic Pump Capacity	61 L/min	<b>16 gpm</b>	61 L/min	<b>16 gpm</b>



MODEL	226D		232D	
Flywheel Power:				
Gross (SAE J1995)	50.1 kW	<b>67.1 hp</b>	50.1 kW	<b>67.1 hp</b>
Net (SAE 1349)*	49.1 kW	<b>65.8 hp</b>	49.1 kW	<b>65.8 hp</b>
Net (SAE 1349)#	44.0 kW	<b>58.9 hp</b>	44.0 kW	<b>58.9 hp</b>
Engine Model	<b>C2.2 CRDI</b>		<b>C2.2 CRDI</b>	
Rated Engine RPM	<b>2800</b>		<b>2800</b>	
Bore	84 mm	<b>3.3"</b>	84 mm	<b>3.3"</b>
Stroke	100 mm	<b>3.9"</b>	100 mm	<b>3.9"</b>
Displacement	2.2 L	<b>134.3 in<sup>3</sup></b>	2.2 L	<b>134.3 in<sup>3</sup></b>
No. Cylinders	<b>4</b>		<b>4</b>	
One Speed Forward	12.3 km/h	<b>7.6 mph</b>	12.3 km/h	<b>7.6 mph</b>
Two Speed Forward	17.8 km/h	<b>11.1 mph</b>	17.8 km/h	<b>11.1 mph</b>
One Speed Reverse	12.3 km/h	<b>7.6 mph</b>	12.3 km/h	<b>7.6 mph</b>
Two Speed Reverse	17.8 km/h	<b>11.1 mph</b>	17.8 km/h	<b>11.1 mph</b>
Hydraulic Cycle Time, Empty Bucket:	<b>Seconds</b>		<b>Seconds</b>	
Raise	<b>2.6</b>		<b>4.4</b>	
Dump	<b>2.1</b>		<b>2.1</b>	
Lower (Empty, Float Down)	<b>2.9</b>		<b>6.6</b>	
Total	<b>7.6</b>		<b>13.1</b>	
Tread Width, Standard	242 mm	<b>9.5"</b>	242 mm	<b>9.5"</b>
Width Over Tires	1497 mm	<b>58.9"</b>	1497 mm	<b>58.9"</b>
Ground Clearance	175 mm	<b>6.9"</b>	175 mm	<b>6.9"</b>
Fuel Tank Capacity	59 L	<b>15.5 U.S. gal</b>	59 L	<b>15.5 U.S. gal</b>
Hydraulic Tank Capacity	34 L	<b>9.0 U.S. gal</b>	34 L	<b>9.0 U.S. gal</b>
Hydraulic System Capacity (includes tank)	45 L	<b>11.9 U.S. gal</b>	45 L	<b>11.9 U.S. gal</b>
Hydraulic Pump Capacity, Standard	69 L/min	<b>18 gpm</b>	69 L/min	<b>18 gpm</b>
Hydraulic Pressure, Standard	23 000 kPa	<b>3336 psi</b>	23 000 kPa	<b>3336 psi</b>
Hydraulic Pump Capacity, XPS	99 L/min	<b>26 gpm</b>	99 L/min	<b>26 gpm</b>
Hydraulic Pressure, XPS	23 000 kPa	<b>3336 psi</b>	23 000 kPa	<b>3336 psi</b>

\*Meets U.S. EPA Tier 4 Final, EU Stage IIIB, Japan 2011 (Tier 4 Interim) emission standards.

#Meets Tier 4 Interim, Stage IIIA, Japan 2006 (Tier 3) equivalent emission standards OR Tier 2, Stage II, Japan 2001 (Tier 2) equivalent emission standards.

MODEL	236D		242D		246D	
Flywheel Power:						
Gross (SAE J1995)	55.4 kW	<b>74.3 hp</b>	55.4 kW	<b>74.3 hp</b>	55.4 kW	<b>74.3 hp</b>
Net (SAE 1349)*	54.6 kW	<b>73.2 hp</b>	54.6 kW	<b>73.2 hp</b>	54.6 kW	<b>73.2 hp</b>
Net (SAE 1349)†	54.2 kW	<b>72.7 hp</b>	54.2 kW	<b>72.7 hp</b>	54.0 kW	<b>72.4 hp</b>
Net (SAE 1349)#	53.8 kW	<b>72.1 hp</b>	53.8 kW	<b>72.1 hp</b>	53.6 kW	<b>71.8 hp</b>
Engine Model	<b>C3.3B DIT</b>		<b>C3.3B DIT</b>		<b>C3.3B DIT</b>	
Rated Engine RPM	<b>2400</b>		<b>2400</b>		<b>2400</b>	
Bore	94 mm	<b>3.7"</b>	94 mm	<b>3.7"</b>	94 mm	<b>3.7"</b>
Stroke	120 mm	<b>4.7"</b>	120 mm	<b>4.7"</b>	120 mm	<b>4.7"</b>
Displacement	3.3 L	<b>203 in³</b>	3.3 L	<b>203 in³</b>	3.3 L	<b>203 in³</b>
No. Cylinders	<b>4</b>		<b>4</b>		<b>4</b>	
One Speed Forward	0-11.2 km/h	<b>0-7.0 mph</b>	0-12.1 km/h	<b>0-7.5 mph</b>	0-12.5 km/h	<b>0-7.7 mph</b>
Two Speed Forward	0-17.1 km/h	<b>0-10.6 mph</b>	0-18.5 km/h	<b>0-11.5 mph</b>	0-17.7 km/h	<b>0-11.0 mph</b>
One Speed Reverse	0-11.2 km/h	<b>0-7.0 mph</b>	0-12.1 km/h	<b>0-7.5 mph</b>	0-12.5 km/h	<b>0-7.7 mph</b>
Two Speed Reverse	0-17.1 km/h	<b>0-10.6 mph</b>	0-18.5 km/h	<b>0-11.5 mph</b>	0-17.7 km/h	<b>0-11.0 mph</b>
Hydraulic Cycle Time, Empty Bucket:	<b>Seconds</b>		<b>Seconds</b>		<b>Seconds</b>	
Raise	<b>3.1</b>		<b>4.4</b>		<b>3.1</b>	
Dump	<b>2.4</b>		<b>2.4</b>		<b>2.5</b>	
Lower (Empty, Float Down)	<b>3.6</b>		<b>3.6</b>		<b>4.0</b>	
Total	<b>9.1</b>		<b>10.4</b>		<b>9.6</b>	
Tread Width, Standard	1371 mm	<b>54"</b>	1371 mm	<b>54"</b>	1371 mm	<b>54"</b>
Width Over Tires	1676 mm	<b>66"</b>	1676 mm	<b>66"</b>	1676 mm	<b>66"</b>
Ground Clearance	195 mm	<b>7.7"</b>	222 mm	<b>8.7"</b>	226 mm	<b>8.9"</b>
Fuel Tank Capacity	105 L	<b>27.7 U.S. gal</b>	105 L	<b>27.7 U.S. gal</b>	94 L	<b>24.8 U.S. gal</b>
Hydraulic Tank Capacity	39 L	<b>10.3 U.S. gal</b>	39 L	<b>10.3 U.S. gal</b>	39 L	<b>10.3 U.S. gal</b>
Hydraulic System Capacity (includes tank)	50 L	<b>13.2 U.S. gal</b>	50 L	<b>13.2 U.S. gal</b>	52 L	<b>13.7 U.S. gal</b>
Hydraulic Pump Capacity, Standard	76 L/min	<b>20 gpm</b>	76 L/min	<b>20 gpm</b>	86 L/min	<b>23 gpm</b>
Hydraulic Pressure, Standard	23 000 kPa	<b>3335 psi</b>	23 000 kPa	<b>3335 psi</b>	23 000 kPa	<b>3335 psi</b>
Hydraulic Pump Capacity, XPS	112 L/min	<b>30 gpm</b>	112 L/min	<b>30 gpm</b>	121 L/min	<b>32 gpm</b>
Hydraulic Pressure, XPS	23 000 kPa	<b>3335 psi</b>	23 000 kPa	<b>3335 psi</b>	28 000 kPa	<b>4061 psi</b>

\*Meets Tier 4 Final, Stage IIIB, Japan 2011 (Tier 4 Interim) emission standards.

†Meets Tier 4 Interim, Stage IIIA, Japan 2006 (Tier 3) equivalent emission standards OR Tier 2, Stage II, Japan 2001 (Tier 2) equivalent emission standards.

#Meets Tier 4 Interim, Stage IIIA, Japan 2006 (Tier 3) equivalent emission standards OR Tier 2, Stage II, Japan 2001 (Tier 2) equivalent emission standards.

MODEL	262D		272D2		272D2 XHP	
Flywheel Power:						
Gross (SAE J1995)	55.4 kW	<b>74.3 hp</b>	73.2 kW	<b>98.2 hp</b>	82.0 kW	<b>110.0 hp</b>
Net (SAE 1349)*	54.6 kW	<b>73.2 hp</b>	70.6 kW	<b>94.7 hp</b>	79.0 kW	<b>105.9 hp</b>
Net (SAE 1349)†	54.0 kW	<b>72.4 hp</b>	—	—	—	—
Net (SAE 1349)#	53.6 kW	<b>71.8 hp</b>	—	—	—	—
Engine Model	<b>C3.3B DIT</b>		<b>C3.8 DIT</b>		<b>C3.8 DITA</b>	
Rated Engine RPM	<b>2400</b>		<b>2400</b>		<b>2400</b>	
Bore	94 mm	<b>3.7"</b>	100 mm	<b>3.9"</b>	100 mm	<b>3.9"</b>
Stroke	120 mm	<b>4.7"</b>	120 mm	<b>4.7"</b>	120 mm	<b>4.7"</b>
Displacement	3.3 L	<b>203 in³</b>	3.8 L	<b>231.9 in³</b>	3.8 L	<b>231.9 in³</b>
No. Cylinders	<b>4</b>		<b>4</b>		<b>4</b>	
One Speed Forward	0-12.5 km/h	<b>0-7.7 mph</b>	10.6 km/h	<b>6.6 mph</b>	10.6 km/h	<b>6.6 mph</b>
Two Speed Forward	0-17.7 km/h	<b>0-11.0 mph</b>	15.1 km/h	<b>9.4 mph</b>	15.1 km/h	<b>9.4 mph</b>
One Speed Reverse	0-12.5 km/h	<b>0-7.7 mph</b>	10.6 km/h	<b>6.6 mph</b>	10.6 km/h	<b>6.6 mph</b>
Two Speed Reverse	0-17.7 km/h	<b>0-11.0 mph</b>	15.1 km/h	<b>9.4 mph</b>	15.1 km/h	<b>9.4 mph</b>
Hydraulic Cycle Time, Empty Bucket:	<b>Seconds</b>		<b>Seconds</b>		<b>Seconds</b>	
Raise	<b>4.6</b>		<b>5.2</b>		<b>4.4</b>	
Dump	<b>2.3</b>		<b>2.3</b>		<b>2.0</b>	
Lower (Empty, Float Down)	<b>4.0</b>		<b>4.6</b>		<b>4.7</b>	
Total	<b>10.9</b>		<b>12.1</b>		<b>11.1</b>	
Tread Width, Standard	1371 mm	<b>54"</b>	1524 mm	<b>60"</b>	1524 mm	<b>60"</b>
Width Over Tires	1676 mm	<b>66"</b>	1829 mm	<b>72"</b>	1930 mm	<b>76"</b>
Ground Clearance	226 mm	<b>8.9"</b>	226 mm	<b>8.9"</b>	263 mm	<b>10.4"</b>
Fuel Tank Capacity	94 L	<b>24.8 U.S. gal</b>	122 L	<b>32.2 U.S. gal</b>	122 L	<b>32.2 U.S. gal</b>
Hydraulic Tank Capacity	39 L	<b>10.3 U.S. gal</b>	39 L	<b>10.3 U.S. gal</b>	39 L	<b>10.3 U.S. gal</b>
Hydraulic System Capacity (includes tank)	52 L	<b>13.7 U.S. gal</b>	55 L	<b>14.5 U.S. gal</b>	55 L	<b>14.5 U.S. gal</b>
Hydraulic Pump Capacity, Standard	86 L/min	<b>23 gpm</b>	86 L/min	<b>23 gpm</b>	86 L/min	<b>23 gpm</b>
Hydraulic Pressure, Standard	23 000 kPa	<b>3335 psi</b>	23 000 kPa	<b>3336 psi</b>	23 000 kPa	<b>3336 psi</b>
Hydraulic Pump Capacity, XPS	121 L/min	<b>32 gpm</b>	121 L/min	<b>32 gpm</b>	—	—
Hydraulic Pressure, XPS	28 000 kPa	<b>4061 psi</b>	28 000 kPa	<b>4061 psi</b>	—	—
Hydraulic Pump Capacity, XHP	—	—	—	—	150 L/min	<b>40 gpm</b>
Hydraulic Pressure, XHP	—	—	—	—	28 000 kPa	<b>4061 psi</b>

\*Meets Tier 4 Final, Stage IIIB, Japan 2011 (Tier 4 Interim) emission standards.

†Meets Tier 4 Interim, Stage IIIA, Japan 2006 (Tier 3) equivalent emission standards OR Tier 2, Stage II, Japan 2001 (Tier 2) equivalent emission standards.

#Meets Tier 4 Interim, Stage IIIA, Japan 2006 (Tier 3) equivalent emission standards OR Tier 2, Stage II, Japan 2001 (Tier 2) equivalent emission standards.

Bucket Type	General Purpose						Multi-Purpose			
Bucket Width	1520 mm (60")			1680 mm (66")			1520 mm (60")			
Tire Size	10 x 16.5			10 x 16.5			10 x 16.5			
Ground Engaging Type	Holes Only	Bolt-on Edge	Bolt-on Teeth	Holes Only	Bolt-on Edge	Bolt-on Teeth	Holes Only	Bolt-on Edge		
Bucket Assembly No.	165-6152	152-0224	152-0223	165-6153	152-0226	152-0225	154-5004	154-5045		
Rated bucket capacity	m <sup>3</sup>	0.36	0.37	0.36	0.40	0.40	0.41	0.30	0.31	
	yd <sup>3</sup>	<b>0.47</b>	<b>0.48</b>	<b>0.47</b>	<b>0.52</b>	<b>0.52</b>	<b>0.53</b>	<b>0.39</b>	<b>0.41</b>	
Struck capacity	m <sup>3</sup>	0.26	0.27	0.26	0.29	0.29	0.29	0.22	0.22	
	yd <sup>3</sup>	<b>0.34</b>	<b>0.35</b>	<b>0.34</b>	<b>0.38</b>	<b>0.38</b>	<b>0.38</b>	<b>0.29</b>	<b>0.29</b>	
Width	mm	1576	1586	1576	1730	1740	1730	1595	1595	
	in	<b>62</b>	<b>62</b>	<b>62</b>	<b>68</b>	<b>68</b>	<b>68</b>	<b>63</b>	<b>63</b>	
Dump clearance at maximum lift/dump	mm	2133	2103	2069	2130	2100	2066	2122	2092	
	in	<b>84</b>	<b>83</b>	<b>81</b>	<b>84</b>	<b>83</b>	<b>81</b>	<b>84</b>	<b>82</b>	
Reach at maximum lift/dump	mm	546	557	620	549	560	623	560	571	
	in	<b>21</b>	<b>22</b>	<b>24</b>	<b>22</b>	<b>22</b>	<b>25</b>	<b>22</b>	<b>22</b>	
Floor angle at maximum lift/dump	degrees	<b>39.9</b>	<b>39.9</b>	<b>39.9</b>	<b>40</b>	<b>40</b>	<b>40</b>	<b>40.2</b>	<b>40.2</b>	
Floor angle at maximum lift/rack back	degrees	<b>96.7</b>	<b>96.7</b>	<b>96.7</b>	<b>96.5</b>	<b>96.5</b>	<b>96.5</b>	<b>96.4</b>	<b>96.4</b>	
Clearance at maximum lift/level bucket	mm	2658	2642	2657	2656	2640	2655	2655	2683	
	in	<b>105</b>	<b>104</b>	<b>105</b>	<b>105</b>	<b>104</b>	<b>105</b>	<b>105</b>	<b>106</b>	
Hinge pin height at maximum lift	mm	2849	2849	2849	2849	2849	2849	2849	2849	
	in	<b>112</b>	<b>112</b>	<b>112</b>	<b>112</b>	<b>112</b>	<b>112</b>	<b>112</b>	<b>112</b>	
Maximum overall height	mm	3762	3790	3860	3759	3787	3857	3746	3774	
	in	<b>148</b>	<b>149</b>	<b>152</b>	<b>148</b>	<b>149</b>	<b>152</b>	<b>147</b>	<b>149</b>	
Reach at level lift arm/bucket	mm	1333	1361	1431	1335	1363	1433	1346	1374	
	in	<b>52</b>	<b>54</b>	<b>56</b>	<b>53</b>	<b>54</b>	<b>56</b>	<b>53</b>	<b>54</b>	
Maximum floor angle at minimum lift	degrees	<b>26.1</b>	<b>26.1</b>	<b>26.1</b>	<b>26</b>	<b>26</b>	<b>26</b>	<b>25.8</b>	<b>25.8</b>	
Dig depth with level bucket	mm	0	16	1	0	16	1	0	15	
	in	<b>0.0</b>	<b>0.6</b>	<b>0.0</b>	<b>0.0</b>	<b>0.6</b>	<b>0.0</b>	<b>0.0</b>	<b>0.6</b>	
Overall length with bucket on ground	mm	3286	3314	3384	3286	3314	3384	3290	3318	
	in	<b>129</b>	<b>130</b>	<b>133</b>	<b>129</b>	<b>130</b>	<b>133</b>	<b>130</b>	<b>131</b>	
Front clearance circle radius (with bucket)	mm	1989	2016	2079	2021	2048	2110	1992	2020	
	in	<b>78</b>	<b>79</b>	<b>82</b>	<b>80</b>	<b>81</b>	<b>83</b>	<b>78</b>	<b>80</b>	
Tipping load	216B3	kg	1213	1158	1187	1194	1140	1171	1074	1031
		lb	<b>2673</b>	<b>2554</b>	<b>2616</b>	<b>2631</b>	<b>2513</b>	<b>2582</b>	<b>2367</b>	<b>2272</b>
	226B3	kg	1293	1238	1267	1274	1219	1251	1153	1109
		lb	<b>2850</b>	<b>2729</b>	<b>2792</b>	<b>2808</b>	<b>2688</b>	<b>2759</b>	<b>2541</b>	<b>2445</b>
Breakout force — lift	216B3	kg	1437	1389	1421	1424	1374	1408	1330	1286
		lb	<b>3168</b>	<b>3062</b>	<b>3132</b>	<b>3140</b>	<b>3030</b>	<b>3104</b>	<b>2932</b>	<b>2835</b>
	226B3	kg	1437	1389	1421	1424	1374	1408	1330	1286
		lb	<b>3168</b>	<b>3062</b>	<b>3132</b>	<b>3140</b>	<b>3030</b>	<b>3104</b>	<b>2932</b>	<b>2835</b>
Breakout force — tilt	216B3	kg	1700	1596	1681	1694	1590	1677	1631	1539
		lb	<b>3747</b>	<b>3518</b>	<b>3705</b>	<b>3735</b>	<b>3506</b>	<b>3697</b>	<b>3596</b>	<b>3393</b>
	226B3	kg	1700	1596	1681	1694	1590	1677	1631	1539
		lb	<b>3747</b>	<b>3518</b>	<b>3705</b>	<b>3735</b>	<b>3506</b>	<b>3697</b>	<b>3596</b>	<b>3393</b>
Operating weight	216B3	kg	2637	2667	2654	2654	2687	2670	2769	2798
		lb	<b>5814</b>	<b>5880</b>	<b>5850</b>	<b>5851</b>	<b>5924</b>	<b>5887</b>	<b>6103</b>	<b>6169</b>
	226B3	kg	2669	2699	2686	2686	2719	2702	2801	2830
		lb	<b>5885</b>	<b>5951</b>	<b>5921</b>	<b>5922</b>	<b>5994</b>	<b>5958</b>	<b>6174</b>	<b>6240</b>

Bucket Type	Multi-Purpose					Dirt				
Bucket Width	1520 mm (60")	1680 mm (66")			1520 mm (60")	1680 mm (66")				
Tire Size	10 x 16.5	10 x 16.5			10 x 16.5		10 x 16.5			
Ground Engaging Type	Bolt-on Teeth	Holes Only	Bolt-on Edge	Bolt-on Teeth	Holes Only	Bolt-on Edge	Holes Only	Bolt-on Edge		
Bucket Assembly No.	154-5046	154-5008	154-5047	154-5048	165-6156	152-0231	165-6157	152-0232		
Rated bucket capacity	m <sup>3</sup>	0.30	0.33	0.33	0.34	0.34	0.35	0.37	0.38	
	yd <sup>3</sup>	<b>0.39</b>	<b>0.43</b>	<b>0.43</b>	<b>0.44</b>	<b>0.44</b>	<b>0.46</b>	<b>0.48</b>	<b>0.49</b>	
Struck capacity	m <sup>3</sup>	0.22	0.24	0.25	0.24	0.25	0.25	0.27	0.27	
	yd <sup>3</sup>	<b>0.29</b>	<b>0.31</b>	<b>0.33</b>	<b>0.31</b>	<b>0.33</b>	<b>0.33</b>	<b>0.35</b>	<b>0.35</b>	
Width	mm	1595	1749	1749	1749	1576	1586	1730	1740	
	in	<b>63</b>	<b>69</b>	<b>69</b>	<b>69</b>	<b>62</b>	<b>62</b>	<b>68</b>	<b>69</b>	
Dump clearance at maximum lift/dump	mm	2058	2122	2092	2058	2169	2140	2169	2140	
	in	<b>81</b>	<b>84</b>	<b>82</b>	<b>81</b>	<b>85</b>	<b>84</b>	<b>85</b>	<b>84</b>	
Reach at maximum lift/dump	mm	634	560	571	634	505	520	505	520	
	in	<b>25</b>	<b>22</b>	<b>22</b>	<b>25</b>	<b>20</b>	<b>20</b>	<b>20</b>	<b>20</b>	
Floor angle at maximum lift/dump	degrees	<b>40.2</b>	<b>40.2</b>	<b>40.2</b>	<b>40.2</b>	<b>39.9</b>	<b>39.9</b>	<b>39.9</b>	<b>39.9</b>	
Floor angle at maximum lift/rack back	degrees	<b>96.4</b>	<b>96.4</b>	<b>96.4</b>	<b>96.4</b>	<b>96.7</b>	<b>96.7</b>	<b>96.7</b>	<b>96.7</b>	
Clearance at maximum lift/level bucket	mm	2654	2655	2683	2654	2661	2648	2661	2648	
	in	<b>104</b>	<b>105</b>	<b>106</b>	<b>104</b>	<b>105</b>	<b>104</b>	<b>105</b>	<b>104</b>	
Hinge pin height at maximum lift	mm	2849	2849	2849	2849	2849	2849	2849	2849	
	in	<b>112</b>	<b>112</b>	<b>112</b>	<b>112</b>	<b>112</b>	<b>112</b>	<b>112</b>	<b>112</b>	
Maximum overall height	mm	3844	3746	3774	3844	3709	3739	3709	3739	
	in	<b>151</b>	<b>147</b>	<b>149</b>	<b>151</b>	<b>146</b>	<b>147</b>	<b>146</b>	<b>147</b>	
Reach at level lift arm/bucket	mm	1444	1346	1374	1444	1280	1310	1280	1310	
	in	<b>57</b>	<b>53</b>	<b>54</b>	<b>57</b>	<b>50</b>	<b>52</b>	<b>50</b>	<b>52</b>	
Maximum floor angle at minimum lift	degrees	<b>25.8</b>	<b>25.8</b>	<b>25.8</b>	<b>25.8</b>	<b>26.1</b>	<b>26.1</b>	<b>26.1</b>	<b>26.1</b>	
Dig depth with level bucket	mm	1	0	16	1	0	16	0	16	
	in	<b>0.0</b>	<b>0.0</b>	<b>0.6</b>	<b>0.0</b>	<b>0.0</b>	<b>0.6</b>	<b>0.0</b>	<b>0.6</b>	
Overall length with bucket on ground	mm	3388	3290	3318	3388	3233	3263	3233	3263	
	in	<b>133</b>	<b>130</b>	<b>131</b>	<b>133</b>	<b>127</b>	<b>128</b>	<b>127</b>	<b>128</b>	
Front clearance circle radius (with bucket)	mm	2083	1992	2020	2113	1940	1970	1970	2000	
	in	<b>82</b>	<b>78</b>	<b>80</b>	<b>83</b>	<b>76</b>	<b>78</b>	<b>78</b>	<b>79</b>	
Tipping load	216B3	kg	1058	1053	1001	1032	1304	1251	1280	1223
		lb	<b>2332</b>	<b>2321</b>	<b>2207</b>	<b>2275</b>	<b>2875</b>	<b>2758</b>	<b>2823</b>	<b>2696</b>
	226B3	kg	1137	1132	1079	1111	1386	1332	1363	1304
		lb	<b>2506</b>	<b>2495</b>	<b>2379</b>	<b>2449</b>	<b>3056</b>	<b>2937</b>	<b>3004</b>	<b>2875</b>
Breakout force — lift	216B3	kg	1316	1314	1265	1298	1515	1466	1495	1444
		lb	<b>2900</b>	<b>2896</b>	<b>2789</b>	<b>2860</b>	<b>3339</b>	<b>3232</b>	<b>3295</b>	<b>3183</b>
	226B3	kg	1316	1314	1265	1298	1515	1466	1495	1444
		lb	<b>2900</b>	<b>2896</b>	<b>2789</b>	<b>2860</b>	<b>3339</b>	<b>3232</b>	<b>3295</b>	<b>3183</b>
Breakout force — tilt	216B3	kg	1620	1618	1518	1601	1853	1740	1842	1727
		lb	<b>3571</b>	<b>3568</b>	<b>3346</b>	<b>3529</b>	<b>4084</b>	<b>3835</b>	<b>4061</b>	<b>3807</b>
	226B3	kg	1620	1618	1518	1601	1853	1740	1842	1727
		lb	<b>3571</b>	<b>3568</b>	<b>3346</b>	<b>3529</b>	<b>4084</b>	<b>3835</b>	<b>4061</b>	<b>3807</b>
Operating weight	216B3	kg	2785	2787	2820	2803	2579	2609	2604	2637
		lb	<b>6139</b>	<b>6144</b>	<b>6216</b>	<b>6180</b>	<b>5685</b>	<b>5751</b>	<b>5740</b>	<b>5813</b>
	226B3	kg	2817	2819	2852	2835	2611	2641	2636	2669
		lb	<b>6210</b>	<b>6215</b>	<b>6287</b>	<b>6251</b>	<b>5756</b>	<b>5822</b>	<b>5811</b>	<b>5883</b>

Work Tool		Pallet Fork			
Tine Length		910 mm (36")	1070 mm (42")	1220 mm (48")	
Tire Size		10 x 16.5	10 x 16.5	10 x 16.5	
Carriage Assembly No.		353-1694	353-1696	353-1697	
Carriage overall width without step	mm	1157	1157	1157	
	in	45	45	45	
Carriage step additional width	mm	108	108	108	
	in	4.25	4.25	4.25	
Carriage height above blade top	mm	923.5	923.5	923.5	
	in	36.4	36.4	36.4	
Blade surface height at maximum height	mm	2741	2741	2741	
	in	107.9	107.9	107.9	
Shank front face reach at maximum height	mm	290	290	290	
	in	11.4	11.4	11.4	
Blade surface height at level lift arms	mm	1383	1383	1383	
	in	54.4	54.4	54.4	
Shank front face reach at level lift arms	mm	743	743	743	
	in	29.3	29.3	29.3	
Blade surface height at minimum lift	mm	91	91	91	
	in	3.6	3.6	3.6	
Shank front face reach at minimum lift	mm	345	345	345	
	in	13.6	13.6	13.6	
Overall length at minimum lift, level tine	mm	3602	3762	3912	
	in	141.8	148.1	154.0	
Tipping load	216B3	kg	949	846	
		lb	2093	1864	
	226B3	kg	1012	903	
		lb	2230	1990	
	Operating weight	216B3	kg	2620	2640
			lb	5775	5820
226B3		kg	2652	2672	
		lb	5846	5890	

Bucket Type		General Purpose: Bolt-on Edge		
		1520 mm (60")	1680 mm (66")	1830 mm (72")
Bucket Width		1520 mm (60")	1680 mm (66")	1830 mm (72")
Tire Size		10 x 16.5	10 x 16.5	10 x 16.5
Ground Engaging Type		Bolt-on Edge	Bolt-on Edge	Bolt-on Edge
Bucket Assembly No.		279-5365	279-5369	279-5373
Rated bucket capacity	m <sup>3</sup>	0.36	0.40	0.44
	yd <sup>3</sup>	0.47	0.52	0.58
Struck capacity	m <sup>3</sup>	0.27	0.29	0.31
	yd <sup>3</sup>	0.35	0.38	0.41
Width	mm	1586	1740	1893
	in	62.4	68.5	74.5
Dump clearance at maximum lift/dump	mm	2003	2000	1999
	in	78.9	78.7	78.7
Reach at maximum lift/dump	mm	577	579	580
	in	22.7	22.8	22.8
Floor angle at maximum lift/dump	degrees	-46.8	-46.9	-46.9
Floor angle at maximum lift/rack back	degrees	88.8	88.7	88.7
Clearance at maximum lift/level bucket	mm	2607	2614	2613
	in	102.6	102.9	102.9
Hinge pin height at maximum lift	mm	2818	2816	2815
	in	110.9	110.9	110.8
Maximum overall height	mm	3731	3729	3728
	in	146.9	146.8	146.8
Reach at level lift arm/bucket	mm	1371	1374	1374
	in	54.0	54.1	54.1
Maximum floor angle at minimum lift	degrees	26.6	26.5	26.4
Dig depth with level bucket	mm	2	9	8
	in	0.1	0.4	0.3
Overall length with bucket on ground	mm	3317	3319	3319
	in	130.6	130.7	130.7
Front clearance circle radius (with bucket)	mm	2049	2080	2114
	in	80.7	81.9	83.2
Tipping load	kg	1299.1	1247.7	1230.7
	lb	2864	2751	2713
Breakout force — lift	kg	1438.2	1396.7	1383.6
	lb	3171	3079	3050
Breakout force — tilt	kg	1442.4	1408.8	1397.2
	lb	3180	3106	3080
Operating weight	kg	2625.8	2677.2	2692.7
	lb	5789	5902	5936

Bucket Type		Multi-Purpose: Bolt-on Edge		
Bucket Width		1520 mm (60")	1680 mm (66")	1830 mm (72")
Tire Size		10 x 16.5	10 x 16.5	10 x 16.5
Ground Engaging Type		Bolt-on Edge	Bolt-on Edge	Bolt-on Edge
Bucket Assembly No.		279-5381	279-5391	279-5399
Rated bucket capacity	m <sup>3</sup>	0.30	0.34	0.37
	yd <sup>3</sup>	<b>0.39</b>	<b>0.44</b>	<b>0.48</b>
Struck capacity	m <sup>3</sup>	0.22	0.25	0.26
	yd <sup>3</sup>	<b>0.29</b>	<b>0.33</b>	<b>0.34</b>
Width	mm	1595	1749	1902
	in	<b>62.8</b>	<b>68.9</b>	<b>74.9</b>
Dump clearance at maximum lift/dump	mm	1986	1985	1983
	in	<b>78.2</b>	<b>78.1</b>	<b>78.1</b>
Reach at maximum lift/dump	mm	588	590	591
	in	<b>23.2</b>	<b>23.2</b>	<b>23.3</b>
Floor angle at maximum lift/dump	degrees	-47.1	-47.2	-47.2
Floor angle at maximum lift/rack back	degrees	<b>88.6</b>	<b>88.5</b>	<b>88.5</b>
Clearance at maximum lift/level bucket	mm	2602	2600	2598
	in	<b>102.5</b>	<b>102.4</b>	<b>102.3</b>
Hinge pin height at maximum lift	mm	2808	2811	2810
	in	<b>110.5</b>	<b>110.7</b>	<b>110.6</b>
Maximum overall height	mm	3732	3731	3730
	in	<b>146.9</b>	<b>146.9</b>	<b>146.8</b>
Reach at level lift arm/bucket	mm	1385	1387	1388
	in	<b>54.5</b>	<b>54.6</b>	<b>54.6</b>
Maximum floor angle at minimum lift	degrees	<b>26.3</b>	<b>26.2</b>	<b>26.2</b>
Dig depth with level bucket	mm	-2	-4	-5
	in	<b>-0.1</b>	<b>-0.1</b>	<b>-0.2</b>
Overall length with bucket on ground	mm	3325	3324	3324
	in	<b>130.9</b>	<b>130.9</b>	<b>130.9</b>
Front clearance circle radius (with bucket)	mm	2058	2089	2123
	in	<b>81.0</b>	<b>82.3</b>	<b>83.6</b>
Tipping load	kg	1138.0	1106.9	1085.1
	lb	<b>2509</b>	<b>2440</b>	<b>2392</b>
Breakout force — lift	kg	1310.4	1288.7	1270.5
	lb	<b>2889</b>	<b>2841</b>	<b>2801</b>
Breakout force — tilt	kg	1344.3	1321.1	1306.7
	lb	<b>2964</b>	<b>2912</b>	<b>2881</b>
Operating weight	kg	2788.1	2810.6	2833.4
	lb	<b>6147</b>	<b>6196</b>	<b>6246</b>



Bucket Type		Dirt: Bolt-on Edge		
Bucket Width		1520 mm (60")	1680 mm (66")	1830 mm (72")
Tire Size		10 x 16.5	10 x 16.5	10 x 16.5
Ground Engaging Type		Bolt-on Edge	Bolt-on Edge	Bolt-on Edge
Bucket Assembly No.		279-5438	279-5441	285-6090
Rated bucket capacity	m <sup>3</sup>	0.34	0.37	0.41
	yd <sup>3</sup>	<b>0.44</b>	<b>0.48</b>	<b>0.54</b>
Struck capacity	m <sup>3</sup>	0.25	0.27	0.30
	yd <sup>3</sup>	<b>0.33</b>	<b>0.35</b>	<b>0.39</b>
Width	mm	1586	1740	1893
	in	<b>62.4</b>	<b>68.5</b>	<b>74.5</b>
Dump clearance at maximum lift/dump	mm	2043	2042	2041
	in	<b>80.4</b>	<b>80.4</b>	<b>80.3</b>
Reach at maximum lift/dump	mm	542	544	545
	in	<b>21.4</b>	<b>21.4</b>	<b>21.4</b>
Floor angle at maximum lift/dump	degrees	<b>-46.8</b>	<b>-46.9</b>	<b>-46.9</b>
Floor angle at maximum lift/rack back	degrees	<b>88.8</b>	<b>88.8</b>	<b>88.8</b>
Clearance at maximum lift/level bucket	mm	2620	2618	2616
	in	<b>103.1</b>	<b>103.1</b>	<b>103.0</b>
Hinge pin height at maximum lift	mm	2815	2817	2816
	in	<b>110.8</b>	<b>110.9</b>	<b>110.9</b>
Maximum overall height	mm	3678	3677	3676
	in	<b>144.8</b>	<b>144.8</b>	<b>144.7</b>
Reach at level lift arm/bucket	mm	1318	1320	1320
	in	<b>51.9</b>	<b>52.0</b>	<b>52.0</b>
Maximum floor angle at minimum lift	degrees	<b>26.6</b>	<b>26.5</b>	<b>26.5</b>
Dig depth with level bucket	mm	15	13	12
	in	<b>0.6</b>	<b>0.5</b>	<b>0.5</b>
Overall length with bucket on ground	mm	3267	3266	3266
	in	<b>128.6</b>	<b>128.6</b>	<b>128.6</b>
Front clearance circle radius (with bucket)	mm	2004	2036	2070
	in	<b>78.9</b>	<b>80.2</b>	<b>81.5</b>
Tipping load	kg	1331.9	1304.6	1287.8
	lb	<b>2936</b>	<b>2876</b>	<b>2839</b>
Breakout force — lift	kg	1463.7	1441.2	1427.5
	lb	<b>3227</b>	<b>3177</b>	<b>3147</b>
Breakout force — tilt	kg	1560.9	1486.2	1473.9
	lb	<b>3441</b>	<b>3276</b>	<b>3249</b>
Operating weight	kg	2626.8	2654.5	2670.6
	lb	<b>5791</b>	<b>5852</b>	<b>5888</b>

Work Tool		Pallet Fork		
Tine Length		910 mm (36")	1070 mm (42")	1220 mm (48")
Tire Size		10 x 16.5	10 x 16.5	10 x 16.5
Carriage Assembly No.		353-1694	353-1696	353-1697
Carriage overall width without step	mm	1160	1160	1160
	in	<b>45.7</b>	<b>45.7</b>	<b>45.7</b>
Carriage step additional width	mm	106	106	106
	in	<b>4.2</b>	<b>4.2</b>	<b>4.2</b>
Carriage height above blade top	mm	926	926	926
	in	<b>36.5</b>	<b>36.5</b>	<b>36.5</b>
Blade surface height at maximum height	mm	2722	2723	2724
	in	<b>107.2</b>	<b>107.2</b>	<b>107.2</b>
Shank front face reach at maximum height	mm	400	401	403
	in	<b>15.7</b>	<b>15.8</b>	<b>15.9</b>
Blade surface height at level lift arms	mm	1433	1433	1432
	in	<b>56.4</b>	<b>56.4</b>	<b>56.4</b>
Shank front face reach at level lift arms	mm	749	749	751
	in	<b>29.5</b>	<b>29.5</b>	<b>29.6</b>
Blade surface height at minimum lift	mm	116	117	117
	in	<b>4.6</b>	<b>4.6</b>	<b>4.6</b>
Shank front face reach at minimum lift	mm	363	363	363
	in	<b>14.3</b>	<b>14.3</b>	<b>14.3</b>
Overall length at minimum lift, level tine	mm	3610	3769	3920
	in	<b>142.1</b>	<b>148.4</b>	<b>154.3</b>
Tipping load	kg	1044.6	984.7	932.6
	lb	<b>2303</b>	<b>2171</b>	<b>2056</b>
Operating weight	kg	2598.6	2608.9	2618.5
	lb	<b>5729</b>	<b>5752</b>	<b>5773</b>

Bucket Type		General Purpose: Bolt-on Edge		
		1520 mm (60")	1680 mm (66")	1830 mm (72")
Bucket Width		1520 mm (60")	1680 mm (66")	1830 mm (72")
Tire Size		10 x 16.5	10 x 16.5	10 x 16.5
Ground Engaging Type		Bolt-on Edge	Bolt-on Edge	Bolt-on Edge
Bucket Assembly No.		279-5365	279-5369	279-5373
Rated bucket capacity	m <sup>3</sup>	0.36	0.40	0.44
	yd <sup>3</sup>	0.47	0.52	0.58
Struck capacity	m <sup>3</sup>	0.27	0.29	0.31
	yd <sup>3</sup>	0.35	0.38	0.41
Width	mm	1586	1740	1893
	in	62.4	68.5	74.5
Dump clearance at maximum lift/dump	mm	2179	2175	2174
	in	85.8	85.6	85.6
Reach at maximum lift/dump	mm	697	700	701
	in	27.4	27.6	27.6
Floor angle at maximum lift/dump	degrees	-47.5	-47.6	-47.6
Floor angle at maximum lift/rack back	degrees	88.2	88.1	88.0
Clearance at maximum lift/level bucket	mm	2803	2798	2796
	in	110.3	110.1	110.1
Hinge pin height at maximum lift	mm	2999	2997	2996
	in	118.1	118.0	118.0
Maximum overall height	mm	3910	3907	3906
	in	153.9	153.8	153.8
Reach at level lift arm/bucket	mm	1332	1335	1336
	in	52.5	52.6	52.6
Maximum floor angle at minimum lift	degrees	26.9	26.8	26.8
Dig depth with level bucket	mm	17	14	12
	in	0.7	0.5	0.5
Overall length with bucket on ground	mm	3321	3320	3320
	in	130.7	130.7	130.7
Front clearance circle radius (with bucket)	mm	2045	2077	2110
	in	80.5	81.8	83.1
Tipping load	kg	1571.5	1520.7	1503.8
	lb	3465	3353	3315
Breakout force — lift	kg	1647.1	1605.4	1592.2
	lb	3631	3539	3510
Breakout force — tilt	kg	1584.3	1561.6	1552.5
	lb	3493	3443	3423
Operating weight	kg	2856.3	2907.7	2923.2
	lb	6297	6410	6444

Bucket Type		Multi-Purpose: Bolt-on Edge		
Bucket Width		1520 mm (60")	1680 mm (66")	1830 mm (72")
Tire Size		10 x 16.5	10 x 16.5	10 x 16.5
Ground Engaging Type		Bolt-on Edge	Bolt-on Edge	Bolt-on Edge
Bucket Assembly No.		279-5381	279-5391	279-5399
Rated bucket capacity	m <sup>3</sup>	0.30	0.34	0.37
	yd <sup>3</sup>	0.39	0.44	0.48
Struck capacity	m <sup>3</sup>	0.22	0.25	0.26
	yd <sup>3</sup>	0.29	0.33	0.34
Width	mm	1595	1749	1902
	in	62.8	68.9	74.9
Dump clearance at maximum lift/dump	mm	2160	2159	2157
	in	85.0	85.0	84.9
Reach at maximum lift/dump	mm	710	712	714
	in	28.0	28.0	28.1
Floor angle at maximum lift/dump	degrees	-47.8	-47.9	-47.9
Floor angle at maximum lift/rack back	degrees	87.9	87.8	87.8
Clearance at maximum lift/level bucket	mm	2785	2782	2780
	in	109.6	109.5	109.4
Hinge pin height at maximum lift	mm	2992	2991	2990
	in	117.8	117.8	117.7
Maximum overall height	mm	3909	3908	3906
	in	153.9	153.8	153.8
Reach at level lift arm/bucket	mm	1347	1349	1350
	in	53.0	53.1	53.2
Maximum floor angle at minimum lift	degrees	26.6	26.6	25.5
Dig depth with level bucket	mm	3	0	-1
	in	0.1	0.0	-0.1
Overall length with bucket on ground	mm	3326	3325	3325
	in	130.9	130.9	130.9
Front clearance circle radius (with bucket)	mm	2054	2086	2119
	in	80.9	82.1	83.4
Tipping load	kg	1408.2	1377.4	1355.6
	lb	3105	3037	2988
Breakout force — lift	kg	1518.6	1497.0	1478.7
	lb	3348	3300	3260
Breakout force — tilt	kg	1524.3	1501.8	1492.5
	lb	3360	3311	3290
Operating weight	kg	3018.6	3041.1	3063.9
	lb	6655	6704	6755

Bucket Type		Dirt: Bolt-on Edge		
Bucket Width		1520 mm (60")	1680 mm (66")	1830 mm (72")
Tire Size		10 x 16.5	10 x 16.5	10 x 16.5
Ground Engaging Type		Bolt-on Edge	Bolt-on Edge	Bolt-on Edge
Bucket Assembly No.		279-5438	279-5441	285-6090
Rated bucket capacity	m <sup>3</sup>	0.34	0.37	0.41
	yd <sup>3</sup>	<b>0.44</b>	<b>0.48</b>	<b>0.54</b>
Struck capacity	m <sup>3</sup>	0.25	0.27	0.30
	yd <sup>3</sup>	<b>0.33</b>	<b>0.35</b>	<b>0.39</b>
Width	mm	1586	1740	1893
	in	<b>62.4</b>	<b>68.5</b>	<b>74.5</b>
Dump clearance at maximum lift/dump	mm	2220	2218	2217
	in	<b>87.4</b>	<b>87.3</b>	<b>87.3</b>
Reach at maximum lift/dump	mm	663	665	666
	in	<b>26.1</b>	<b>26.2</b>	<b>26.2</b>
Floor angle at maximum lift/dump	degrees	<b>-47.5</b>	<b>-47.5</b>	<b>-47.6</b>
Floor angle at maximum lift/rack back	degrees	<b>88.2</b>	<b>88.1</b>	<b>88.1</b>
Clearance at maximum lift/level bucket	mm	2804	2802	2800
	in	<b>110.4</b>	<b>110.3</b>	<b>110.2</b>
Hinge pin height at maximum lift	mm	2999	2998	2997
	in	<b>118.1</b>	<b>118.0</b>	<b>118.0</b>
Maximum overall height	mm	3857	3856	3855
	in	<b>151.9</b>	<b>151.8</b>	<b>151.8</b>
Reach at level lift arm/bucket	mm	1279	1281	1282
	in	<b>50.4</b>	<b>50.4</b>	<b>50.5</b>
Maximum floor angle at minimum lift	degrees	<b>26.9</b>	<b>26.9</b>	<b>26.8</b>
Dig depth with level bucket	mm	19	17	16
	in	<b>0.7</b>	<b>0.7</b>	<b>0.6</b>
Overall length with bucket on ground	mm	3268	3268	3267
	in	<b>128.7</b>	<b>128.6</b>	<b>128.6</b>
Front clearance circle radius (with bucket)	mm	2000	2033	2067
	in	<b>78.8</b>	<b>80.0</b>	<b>81.4</b>
Tipping load	kg	1610.6	1583.5	1567.0
	lb	<b>3551</b>	<b>3491</b>	<b>3454</b>
Breakout force — lift	kg	1675.6	1653.1	1639.3
	lb	<b>3694</b>	<b>3644</b>	<b>3614</b>
Breakout force — tilt	kg	1692.5	1680.7	1671.1
	lb	<b>3731</b>	<b>3705</b>	<b>3684</b>
Operating weight	kg	2857.3	2885.0	2901.1
	lb	<b>6299</b>	<b>6360</b>	<b>6396</b>

Work Tool		Pallet Fork		
Tine Length		910 mm (36")	1070 mm (42")	1220 mm (48")
Tire Size		10 x 16.5	10 x 16.5	10 x 16.5
Carriage Assembly No.		353-1694	353-1696	353-1697
Carriage overall width without step	mm	1160	1160	1160
	in	<b>45.7</b>	<b>45.7</b>	<b>45.7</b>
Carriage step additional width	mm	106	106	106
	in	<b>4.2</b>	<b>4.2</b>	<b>4.2</b>
Carriage height above blade top	mm	926	926	926
	in	<b>36.5</b>	<b>36.5</b>	<b>36.5</b>
Blade surface height at maximum height	mm	2908	2910	2910
	in	<b>114.5</b>	<b>114.6</b>	<b>114.6</b>
Shank front face reach at maximum height	mm	530	531	533
	in	<b>20.8</b>	<b>20.9</b>	<b>21.0</b>
Blade surface height at level lift arms	mm	1588	1589	1589
	in	<b>62.5</b>	<b>62.6</b>	<b>62.6</b>
Shank front face reach at level lift arms	mm	709	710	711
	in	<b>27.9</b>	<b>27.9</b>	<b>28.0</b>
Blade surface height at minimum lift	mm	122	124	124
	in	<b>4.8</b>	<b>4.9</b>	<b>4.9</b>
Shank front face reach at minimum lift	mm	363	363	364
	in	<b>14.3</b>	<b>14.3</b>	<b>14.3</b>
Overall length at minimum lift, level tine	mm	3610	3770	3920
	in	<b>142.1</b>	<b>148.4</b>	<b>154.3</b>
Tipping load	kg	1262.7	1192.6	1131.9
	lb	<b>2784</b>	<b>2629</b>	<b>2495</b>
Operating weight	kg	2829.1	2839.4	2849.0
	lb	<b>6237</b>	<b>6260</b>	<b>6281</b>

Bucket Type		General Purpose: Bolt-on Edge		
Bucket Width		1520 mm (60")	1680 mm (66")	1830 mm (72")
Tire Size		10 x 16.5	10 x 16.5	10 x 16.5
Ground Engaging Type		Bolt-on Edge	Bolt-on Edge	Bolt-on Edge
Bucket Assembly No.		279-5365	279-5369	279-5373
Rated bucket capacity	m <sup>3</sup>	0.36	0.40	0.44
	yd <sup>3</sup>	<b>0.47</b>	<b>0.52</b>	<b>0.58</b>
Struck capacity	m <sup>3</sup>	0.27	0.29	0.31
	yd <sup>3</sup>	<b>0.35</b>	<b>0.38</b>	<b>0.41</b>
Width	mm	1586	1740	1893
	in	<b>62.4</b>	<b>68.5</b>	<b>74.5</b>
Dump clearance at maximum lift/dump	mm	2295	2293	2292
	in	<b>90.4</b>	<b>90.3</b>	<b>90.2</b>
Reach at maximum lift/dump	mm	407	410	410
	in	<b>16.0</b>	<b>16.1</b>	<b>16.2</b>
Floor angle at maximum lift/dump	degrees	<b>-46.9</b>	<b>-47.0</b>	<b>-47.0</b>
Floor angle at maximum lift/rack back	degrees	<b>87.6</b>	<b>87.6</b>	<b>87.6</b>
Clearance at maximum lift/level bucket	mm	2908	2906	2905
	in	<b>114.5</b>	<b>114.4</b>	<b>114.4</b>
Hinge pin height at maximum lift	mm	3120	3118	3118
	in	<b>122.8</b>	<b>122.8</b>	<b>122.7</b>
Maximum overall height	mm	4063	4061	4061
	in	<b>160.0</b>	<b>159.9</b>	<b>159.9</b>
Reach at level lift arm/bucket	mm	1419	1422	1423
	in	<b>55.9</b>	<b>56.0</b>	<b>56.0</b>
Maximum floor angle at minimum lift	degrees	<b>23.4</b>	<b>23.4</b>	<b>23.4</b>
Dig depth with level bucket	mm	-23	-25	-26
	in	<b>-0.9</b>	<b>-1.0</b>	<b>-1.0</b>
Overall length with bucket on ground	mm	3575	3575	3575
	in	<b>140.8</b>	<b>140.8</b>	<b>140.8</b>
Front clearance circle radius (with bucket)	mm	2229	2258	2288
	in	<b>87.8</b>	<b>88.9</b>	<b>90.1</b>
Tipping load	kg	1535.3	1483.8	1466.8
	lb	<b>3385</b>	<b>3271</b>	<b>3234</b>
Breakout force — lift	kg	1676.0	1641.4	1629.6
	lb	<b>3695</b>	<b>3619</b>	<b>3593</b>
Breakout force — tilt	kg	2040.2	2017.0	2007.9
	lb	<b>4498</b>	<b>4447</b>	<b>4427</b>
Operating weight	kg	2979.4	3030.8	3046.3
	lb	<b>6568</b>	<b>6682</b>	<b>6716</b>

Bucket Type		Multi-Purpose: Bolt-on Edge		
Bucket Width		1520 mm (60")	1680 mm (66")	1830 mm (72")
Tire Size		10 x 16.5	10 x 16.5	10 x 16.5
Ground Engaging Type		Bolt-on Edge	Bolt-on Edge	Bolt-on Edge
Bucket Assembly No.		279-5381	279-5391	279-5399
Rated bucket capacity	m <sup>3</sup>	0.30	0.34	0.37
	yd <sup>3</sup>	<b>0.39</b>	<b>0.44</b>	<b>0.48</b>
Struck capacity	m <sup>3</sup>	0.22	0.25	0.26
	yd <sup>3</sup>	<b>0.29</b>	<b>0.33</b>	<b>0.34</b>
Width	mm	1595	1749	1902
	in	<b>62.8</b>	<b>68.9</b>	<b>74.9</b>
Dump clearance at maximum lift/dump	mm	2280	2279	2278
	in	<b>89.8</b>	<b>89.7</b>	<b>89.7</b>
Reach at maximum lift/dump	mm	418	419	421
	in	<b>16.5</b>	<b>16.5</b>	<b>16.6</b>
Floor angle at maximum lift/dump	degrees	<b>-47.2</b>	<b>-47.2</b>	<b>-47.3</b>
Floor angle at maximum lift/rack back	degrees	<b>87.7</b>	<b>87.8</b>	<b>87.8</b>
Clearance at maximum lift/level bucket	mm	2899	2898	2897
	in	<b>114.1</b>	<b>114.1</b>	<b>114.1</b>
Hinge pin height at maximum lift	mm	3115	3114	3113
	in	<b>122.6</b>	<b>122.6</b>	<b>122.6</b>
Maximum overall height	mm	4065	4065	4064
	in	<b>160.1</b>	<b>160.0</b>	<b>160.0</b>
Reach at level lift arm/bucket	mm	1433	1435	1436
	in	<b>56.4</b>	<b>56.5</b>	<b>56.5</b>
Maximum floor angle at minimum lift	degrees	<b>23.4</b>	<b>23.4</b>	<b>23.4</b>
Dig depth with level bucket	mm	-32	-33	-34
	in	<b>-1.3</b>	<b>-1.3</b>	<b>-1.3</b>
Overall length with bucket on ground	mm	3575	3575	3575
	in	<b>140.8</b>	<b>140.8</b>	<b>140.8</b>
Front clearance circle radius (with bucket)	mm	2232	2261	2291
	in	<b>87.9</b>	<b>89.0</b>	<b>90.2</b>
Tipping load	kg	1370.7	1339.9	1317.8
	lb	<b>3022</b>	<b>2954</b>	<b>2905</b>
Breakout force — lift	kg	1574.2	1551.1	1536.2
	lb	<b>3471</b>	<b>3419</b>	<b>3387</b>
Breakout force — tilt	kg	1978.5	1956.1	1946.5
	lb	<b>4362</b>	<b>4312</b>	<b>4291</b>
Operating weight	kg	3141.7	3164.2	3187.0
	lb	<b>6926</b>	<b>6976</b>	<b>7026</b>



Bucket Type		Dirt: Bolt-on Edge		
Bucket Width		1520 mm (60")	1680 mm (66")	1830 mm (72")
Tire Size		10 x 16.5	10 x 16.5	10 x 16.5
Ground Engaging Type		Bolt-on Edge	Bolt-on Edge	Bolt-on Edge
Bucket Assembly No.		279-5438	279-5441	285-6090
Rated bucket capacity	m <sup>3</sup>	0.34	0.37	0.41
	yd <sup>3</sup>	<b>0.44</b>	<b>0.48</b>	<b>0.54</b>
Struck capacity	m <sup>3</sup>	0.25	0.27	0.30
	yd <sup>3</sup>	<b>0.33</b>	<b>0.35</b>	<b>0.39</b>
Width	mm	1586	1740	1893
	in	<b>62.4</b>	<b>68.5</b>	<b>74.5</b>
Dump clearance at maximum lift/dump	mm	2335	2334	2334
	in	<b>91.9</b>	<b>91.9</b>	<b>91.9</b>
Reach at maximum lift/dump	mm	373	374	375
	in	<b>14.7</b>	<b>14.7</b>	<b>14.8</b>
Floor angle at maximum lift/dump	degrees	<b>-46.9</b>	<b>-47.0</b>	<b>-47.0</b>
Floor angle at maximum lift/rack back	degrees	<b>87.6</b>	<b>87.6</b>	<b>87.6</b>
Clearance at maximum lift/level bucket	mm	2911	2910	2909
	in	<b>114.6</b>	<b>114.6</b>	<b>114.5</b>
Hinge pin height at maximum lift	mm	3120	3119	3119
	in	<b>122.8</b>	<b>122.8</b>	<b>122.8</b>
Maximum overall height	mm	4010	4009	4008
	in	<b>157.9</b>	<b>157.8</b>	<b>157.8</b>
Reach at level lift arm/bucket	mm	1367	1368	1369
	in	<b>53.8</b>	<b>53.8</b>	<b>53.9</b>
Maximum floor angle at minimum lift	degrees	<b>23.4</b>	<b>23.4</b>	<b>23.4</b>
Dig depth with level bucket	mm	-21	-22	-22
	in	<b>-0.8</b>	<b>-0.9</b>	<b>-0.9</b>
Overall length with bucket on ground	mm	3575	3575	3575
	in	<b>140.8</b>	<b>140.8</b>	<b>140.8</b>
Front clearance circle radius (with bucket)	mm	2182	2211	1228
	in	<b>85.9</b>	<b>87.1</b>	<b>48.4</b>
Tipping load	kg	1572.8	1545.3	1528.6
	lb	<b>3467</b>	<b>3407</b>	<b>3370</b>
Breakout force — lift	kg	1743.7	1725.0	1712.5
	lb	<b>3844</b>	<b>3803</b>	<b>3775</b>
Breakout force — tilt	kg	2177.0	2164.9	2155.2
	lb	<b>4799</b>	<b>4773</b>	<b>4751</b>
Operating weight	kg	2980.4	3008.1	3024.2
	lb	<b>6571</b>	<b>6632</b>	<b>6667</b>

Work Tool		Pallet Fork		
Tine Length		910 mm (36")	1070 mm (42")	1220 mm (48")
Tire Size		10 x 16.5	10 x 16.5	10 x 16.5
Carriage Assembly No.		353-1694	353-1696	353-1697
Carriage overall width without step	mm	1160	1160	1160
	in	45.7	45.7	45.7
Carriage step additional width	mm	106	106	106
	in	4.2	4.2	4.2
Carriage height above blade top	mm	926	926	926
	in	36.5	36.5	36.5
Blade surface height at maximum height	mm	3020	3021	3022
	in	118.9	119.0	119.0
Shank front face reach at maximum height	mm	235	237	239
	in	9.3	9.3	9.4
Blade surface height at level lift arms	mm	1387	1386	1384
	in	54.6	54.6	54.5
Shank front face reach at level lift arms	mm	800	800	802
	in	31.5	31.5	31.6
Blade surface height at minimum lift	mm	78	79	78
	in	3.1	3.1	3.1
Shank front face reach at minimum lift	mm	437	437	437
	in	17.2	17.2	17.2
Overall length at minimum lift, level tine	mm	3861	4021	4171
	in	152.0	158.3	164.2
Tipping load	kg	1237.9	1171.0	1112.8
	lb	2729	2582	2453
Operating weight	kg	2952.2	2962.5	2972.1
	lb	6508	6531	6552

Bucket Type		General Purpose: Bolt-on Edge		
Bucket Width		1520 mm (60")	1680 mm (66")	1830 mm (72")
Tire Size		12 x 16.5	12 x 16.5	12 x 16.5
Ground Engaging Type		Bolt-on Edge	Bolt-on Edge	Bolt-on Edge
Bucket Assembly No.		279-5365	279-5369	279-5373
Rated bucket capacity	m <sup>3</sup>	0.36	0.40	0.44
	yd <sup>3</sup>	<b>0.47</b>	<b>0.52</b>	<b>0.58</b>
Struck capacity	m <sup>3</sup>	0.27	0.29	0.31
	yd <sup>3</sup>	<b>0.35</b>	<b>0.38</b>	<b>0.41</b>
Width	mm	1586	1740	1893
	in	<b>62.4</b>	<b>68.5</b>	<b>74.5</b>
Dump clearance at maximum lift/dump	mm	2218	2215	2215
	in	<b>87.3</b>	<b>87.2</b>	<b>87.2</b>
Reach at maximum lift/dump	mm	558	561	561
	in	<b>22.0</b>	<b>22.1</b>	<b>22.1</b>
Floor angle at maximum lift/dump	degrees	-51.3	-51.4	-51.4
Floor angle at maximum lift/rack back	degrees	<b>88.0</b>	<b>87.9</b>	<b>87.9</b>
Clearance at maximum lift/level bucket	mm	2866	2863	2863
	in	<b>112.8</b>	<b>112.7</b>	<b>112.7</b>
Hinge pin height at maximum lift	mm	3077	3076	3075
	in	<b>121.1</b>	<b>121.1</b>	<b>121.1</b>
Maximum overall height	mm	4004	4002	4001
	in	<b>157.6</b>	<b>157.6</b>	<b>157.5</b>
Reach at level lift arm/bucket	mm	1316	1318	1318
	in	<b>51.8</b>	<b>51.9</b>	<b>51.9</b>
Maximum floor angle at minimum lift	degrees	<b>23.0</b>	<b>23.0</b>	<b>23.0</b>
Dig depth with level bucket	mm	-12	-13	-14
	in	<b>-0.5</b>	<b>-0.5</b>	<b>-0.5</b>
Overall length with bucket on ground	mm	3564	3564	3564
	in	<b>140.3</b>	<b>140.3</b>	<b>140.3</b>
Front clearance circle radius (with bucket)	mm	2341	2383	2426
	in	<b>92.2</b>	<b>93.8</b>	<b>95.5</b>
Tipping load	kg	1873.9	1823.0	1806.0
	lb	<b>4131</b>	<b>4019</b>	<b>3981</b>
Breakout force — lift	kg	1852.8	1818.3	1806.5
	lb	<b>4085</b>	<b>4009</b>	<b>3983</b>
Breakout force — tilt	kg	2023.8	2000.6	1991.5
	lb	<b>4462</b>	<b>4411</b>	<b>4390</b>
Operating weight	kg	3170.3	3221.7	3237.2
	lb	<b>6989</b>	<b>7103</b>	<b>7137</b>

Bucket Type		Multi-Purpose: Bolt-on Edge		
Bucket Width		1520 mm (60")	1680 mm (66")	1830 mm (72")
Tire Size		12 x 16.5	12 x 16.5	12 x 16.5
Ground Engaging Type		Bolt-on Edge	Bolt-on Edge	Bolt-on Edge
Bucket Assembly No.		279-5381	279-5391	279-5399
Rated bucket capacity	m <sup>3</sup>	0.30	0.34	0.37
	yd <sup>3</sup>	<b>0.39</b>	<b>0.44</b>	<b>0.48</b>
Struck capacity	m <sup>3</sup>	0.22	0.25	0.26
	yd <sup>3</sup>	<b>0.29</b>	<b>0.33</b>	<b>0.34</b>
Width	mm	1595	1749	1902
	in	<b>62.8</b>	<b>68.9</b>	<b>74.9</b>
Dump clearance at maximum lift/dump	mm	2203	2202	2201
	in	<b>86.7</b>	<b>86.7</b>	<b>86.6</b>
Reach at maximum lift/dump	mm	568	569	570
	in	<b>22.3</b>	<b>22.4</b>	<b>22.4</b>
Floor angle at maximum lift/dump	degrees	<b>-51.6</b>	<b>-51.6</b>	<b>-51.6</b>
Floor angle at maximum lift/rack back	degrees	<b>87.8</b>	<b>87.8</b>	<b>87.7</b>
Clearance at maximum lift/level bucket	mm	2856	2855	2854
	in	<b>112.5</b>	<b>112.4</b>	<b>112.4</b>
Hinge pin height at maximum lift	mm	3072	3071	3070
	in	<b>120.9</b>	<b>120.9</b>	<b>120.9</b>
Maximum overall height	mm	4005	4004	4004
	in	<b>157.7</b>	<b>157.7</b>	<b>157.6</b>
Reach at level lift arm/bucket	mm	1328	1329	1330
	in	<b>52.3</b>	<b>52.3</b>	<b>52.4</b>
Maximum floor angle at minimum lift	degrees	<b>23.0</b>	<b>23.0</b>	<b>23.0</b>
Dig depth with level bucket	mm	-20	-20	-21
	in	<b>-0.8</b>	<b>-0.8</b>	<b>-0.8</b>
Overall length with bucket on ground	mm	3571	3571	3570
	in	<b>140.6</b>	<b>140.6</b>	<b>140.6</b>
Front clearance circle radius (with bucket)	mm	2344	2386	2428
	in	<b>92.3</b>	<b>93.9</b>	<b>95.6</b>
Tipping load	kg	1706.2	1675.2	1653.1
	lb	<b>3762</b>	<b>3693</b>	<b>3644</b>
Breakout force — lift	kg	1751.5	1728.3	1713.4
	lb	<b>3861</b>	<b>3810</b>	<b>3777</b>
Breakout force — tilt	kg	1962.1	1939.7	1930.1
	lb	<b>4326</b>	<b>4276</b>	<b>4255</b>
Operating weight	kg	3332.6	3355.1	3377.9
	lb	<b>7347</b>	<b>7397</b>	<b>7447</b>

Bucket Type		Dirt: Bolt-on Edge		
Bucket Width		1520 mm (60")	1680 mm (66")	1830 mm (72")
Tire Size		12 x 16.5	12 x 16.5	12 x 16.5
Ground Engaging Type		Bolt-on Edge	Bolt-on Edge	Bolt-on Edge
Bucket Assembly No.		279-5438	279-5441	285-6090
Rated bucket capacity	m <sup>3</sup>	0.34	0.37	0.41
	yd <sup>3</sup>	<b>0.44</b>	<b>0.48</b>	<b>0.54</b>
Struck capacity	m <sup>3</sup>	0.25	0.27	0.30
	yd <sup>3</sup>	<b>0.33</b>	<b>0.35</b>	<b>0.39</b>
Width	mm	1586	1740	1893
	in	<b>62.4</b>	<b>68.5</b>	<b>74.5</b>
Dump clearance at maximum lift/dump	mm	2260	2259	2259
	in	<b>89.0</b>	<b>88.9</b>	<b>88.9</b>
Reach at maximum lift/dump	mm	527	529	529
	in	<b>20.8</b>	<b>20.8</b>	<b>20.8</b>
Floor angle at maximum lift/dump	degrees	-51.3	-51.4	-51.4
Floor angle at maximum lift/rack back	degrees	<b>88.0</b>	<b>87.9</b>	<b>87.9</b>
Clearance at maximum lift/level bucket	mm	2868	2867	2866
	in	<b>112.9</b>	<b>112.9</b>	<b>112.8</b>
Hinge pin height at maximum lift	mm	3077	3076	3076
	in	<b>121.1</b>	<b>121.1</b>	<b>121.1</b>
Maximum overall height	mm	3951	3950	3949
	in	<b>155.5</b>	<b>155.5</b>	<b>155.5</b>
Reach at level lift arm/bucket	mm	1263	1264	1265
	in	<b>49.7</b>	<b>49.8</b>	<b>49.8</b>
Maximum floor angle at minimum lift	degrees	<b>23.0</b>	<b>23.0</b>	<b>23.0</b>
Dig depth with level bucket	mm	-10	-10	-11
	in	<b>-0.4</b>	<b>-0.4</b>	<b>-0.4</b>
Overall length with bucket on ground	mm	3511	3511	3511
	in	<b>138.2</b>	<b>138.2</b>	<b>138.2</b>
Front clearance circle radius (with bucket)	mm	2299	2341	2385
	in	<b>90.5</b>	<b>92.2</b>	<b>93.9</b>
Tipping load	kg	1921.9	1894.6	1878.2
	lb	<b>4237</b>	<b>4177</b>	<b>4141</b>
Breakout force — lift	kg	1928.3	1909.7	1897.2
	lb	<b>4251</b>	<b>4210</b>	<b>4183</b>
Breakout force — tilt	kg	2159.5	2147.4	2137.7
	lb	<b>4761</b>	<b>4734</b>	<b>4713</b>
Operating weight	kg	3171.3	3199.0	3215.1
	lb	<b>6991</b>	<b>7053</b>	<b>7088</b>

Work Tool	Pallet Fork		
Tine Length	910 mm (36")	1070 mm (42")	1220 mm (48")
Tire Size	12 x 16.5	12 x 16.5	12 x 16.5
Carriage Assembly No.	353-1694	353-1696	353-1697
Carriage overall width without step	mm	1160	1160
	in	45.7	45.7
Carriage step additional width	mm	106	106
	in	4.2	4.2
Carriage height above blade top	mm	926	926
	in	36.5	36.5
Blade surface height at maximum height	mm	2970	2970
	in	116.9	116.9
Shank front face reach at maximum height	mm	452	453
	in	17.8	17.8
Blade surface height at level lift arms	mm	1384	1384
	in	54.5	54.5
Shank front face reach at level lift arms	mm	695	696
	in	27.4	27.4
Blade surface height at minimum lift	mm	88	88
	in	3.5	3.5
Shank front face reach at minimum lift	mm	399	399
	in	15.7	15.7
Overall length at minimum lift, level tine	mm	3851	4011
	in	151.6	157.9
Tipping load	kg	1489.6	1408.7
	lb	3284	3106
Operating weight	kg	3143.1	3153.4
	lb	6929	6952

Bucket Type		General Purpose: Bolt-on Edge			
Bucket Width		1680 mm (66")	1830 mm (72")	1981 mm (78")	2134 mm (84")
Tire Size		12 x 16.5	12 x 16.5	12 x 16.5	12 x 16.5
Ground Engaging Type		Bolt-on Edge	Bolt-on Edge	Bolt-on Edge	Bolt-on Edge
Bucket Assembly No.		279-5369	279-5373	279-5377	296-8192
Rated bucket capacity	m <sup>3</sup>	0.40	0.44	0.48	0.63
	yd <sup>3</sup>	<b>0.52</b>	<b>0.58</b>	<b>0.63</b>	<b>0.82</b>
Struck capacity	m <sup>3</sup>	0.29	0.31	0.32	0.59
	yd <sup>3</sup>	<b>0.38</b>	<b>0.41</b>	<b>0.42</b>	<b>0.77</b>
Width	mm	1740	1893	2045	2198
	in	<b>68.5</b>	<b>74.5</b>	<b>80.5</b>	<b>86.5</b>
Dump clearance at maximum lift/dump	mm	2405	2404	2404	2343
	in	<b>94.7</b>	<b>94.7</b>	<b>94.6</b>	<b>92.3</b>
Reach at maximum lift/dump	mm	625	626	626	700
	in	<b>24.6</b>	<b>24.6</b>	<b>24.7</b>	<b>27.6</b>
Floor angle at maximum lift/dump	degrees	<b>-37.9</b>	<b>-38.0</b>	<b>-38.0</b>	<b>-38.0</b>
Floor angle at maximum lift/rack back	degrees	<b>97.1</b>	<b>97.1</b>	<b>97.1</b>	<b>97.0</b>
Clearance at maximum lift/level bucket	mm	2940	2939	2939	2936
	in	<b>115.7</b>	<b>115.7</b>	<b>115.7</b>	<b>115.6</b>
Hinge pin height at maximum lift	mm	3150	3150	3150	3148
	in	<b>124.0</b>	<b>124.0</b>	<b>124.0</b>	<b>124.0</b>
Maximum overall height	mm	4114	4114	4113	4205
	in	<b>162.0</b>	<b>162.0</b>	<b>161.9</b>	<b>165.6</b>
Reach at level lift arm/bucket	mm	1468	1469	1469	1564
	in	<b>57.8</b>	<b>57.8</b>	<b>57.8</b>	<b>61.6</b>
Maximum floor angle at minimum lift	degrees	<b>26.6</b>	<b>26.6</b>	<b>26.6</b>	<b>26.6</b>
Dig depth with level bucket	mm	-14	-14	-15	-17
	in	<b>-0.6</b>	<b>-0.6</b>	<b>-0.6</b>	<b>-0.7</b>
Overall length with bucket on ground	mm	3792	3792	3792	3885
	in	<b>149.3</b>	<b>149.3</b>	<b>149.3</b>	<b>153.0</b>
Front clearance circle radius (with bucket)	mm	2259	2290	2322	2436
	in	<b>88.9</b>	<b>90.1</b>	<b>91.4</b>	<b>95.9</b>
Tipping load	kg	1871.4	1854.3	1839.8	1764.7
	lb	<b>4126</b>	<b>4088</b>	<b>4056</b>	<b>3891</b>
Breakout force — lift	kg	2089.4	2077.5	2069.4	1902.4
	lb	<b>4606</b>	<b>4580</b>	<b>4562</b>	<b>4194</b>
Breakout force — tilt	kg	2947.3	2938.1	2934.0	2612.4
	lb	<b>6498</b>	<b>6477</b>	<b>6468</b>	<b>5759</b>
Operating weight	kg	3423.1	3438.6	3452.9	3489.8
	lb	<b>7547</b>	<b>7581</b>	<b>7612</b>	<b>7694</b>

Bucket Type		Multi-Purpose: Bolt-on Edge		
Bucket Width		1680 mm (66")	1830 mm (72")	1981 mm (78")
Tire Size		12 x 16.5	12 x 16.5	12 x 16.5
Ground Engaging Type		Bolt-on Edge	Bolt-on Edge	Bolt-on Edge
Bucket Assembly No.		279-5391	279-5399	279-5402
Rated bucket capacity	m <sup>3</sup>	0.34	0.37	0.40
	yd <sup>3</sup>	<b>0.44</b>	<b>0.48</b>	<b>0.52</b>
Struck capacity	m <sup>3</sup>	0.25	0.26	0.28
	yd <sup>3</sup>	<b>0.33</b>	<b>0.34</b>	<b>0.37</b>
Width	mm	1749	1902	2045
	in	<b>68.9</b>	<b>74.9</b>	<b>80.5</b>
Dump clearance at maximum lift/dump	mm	2393	2392	2391
	in	<b>94.2</b>	<b>94.2</b>	<b>94.1</b>
Reach at maximum lift/dump	mm	634	635	636
	in	<b>25.0</b>	<b>25.0</b>	<b>25.0</b>
Floor angle at maximum lift/dump	degrees	<b>-38.1</b>	<b>-38.1</b>	<b>-38.1</b>
Floor angle at maximum lift/rack back	degrees	<b>97.0</b>	<b>97.0</b>	<b>97.0</b>
Clearance at maximum lift/level bucket	mm	2933	2932	2931
	in	<b>115.5</b>	<b>115.4</b>	<b>115.4</b>
Hinge pin height at maximum lift	mm	3147	3146	3146
	in	<b>123.9</b>	<b>123.9</b>	<b>123.8</b>
Maximum overall height	mm	4119	4118	4118
	in	<b>162.2</b>	<b>162.1</b>	<b>162.1</b>
Reach at level lift arm/bucket	mm	1479	1480	1481
	in	<b>58.2</b>	<b>58.3</b>	<b>58.3</b>
Maximum floor angle at minimum lift	degrees	<b>26.6</b>	<b>26.6</b>	<b>26.6</b>
Dig depth with level bucket	mm	-21	-21	-22
	in	<b>-0.8</b>	<b>-0.8</b>	<b>-0.8</b>
Overall length with bucket on ground	mm	3798	3798	3798
	in	<b>149.5</b>	<b>149.5</b>	<b>149.5</b>
Front clearance circle radius (with bucket)	mm	2262	2292	2325
	in	<b>89.1</b>	<b>90.2</b>	<b>91.5</b>
Tipping load	kg	1722.8	1700.4	1687.8
	lb	<b>3798</b>	<b>3749</b>	<b>3721</b>
Breakout force — lift	kg	1998.7	1983.7	1968.9
	lb	<b>4406</b>	<b>4373</b>	<b>4341</b>
Breakout force — tilt	kg	2885.5	2875.8	2864.7
	lb	<b>6361</b>	<b>6340</b>	<b>6315</b>
Operating weight	kg	3556.5	3579.3	3599.2
	lb	<b>7841</b>	<b>7891</b>	<b>7935</b>



Bucket Type		Dirt: Bolt-on Edge		
Bucket Width		1680 mm (66")	1830 mm (72")	1981 mm (78")
Tire Size		12 x 16.5	12 x 16.5	12 x 16.5
Ground Engaging Type		Bolt-on Edge	Bolt-on Edge	Bolt-on Edge
Bucket Assembly No.		279-5441	285-6090	268-4083
Rated bucket capacity	m <sup>3</sup>	0.37	0.41	0.44
	yd <sup>3</sup>	<b>0.48</b>	<b>0.54</b>	<b>0.58</b>
Struck capacity	m <sup>3</sup>	0.27	0.30	0.32
	yd <sup>3</sup>	<b>0.35</b>	<b>0.39</b>	<b>0.42</b>
Width	mm	1740	1893	2045
	in	<b>68.5</b>	<b>74.5</b>	<b>80.5</b>
Dump clearance at maximum lift/dump	mm	2440	2440	2439
	in	<b>96.1</b>	<b>96.0</b>	<b>96.0</b>
Reach at maximum lift/dump	mm	584	585	585
	in	<b>23.0</b>	<b>23.0</b>	<b>23.0</b>
Floor angle at maximum lift/dump	degrees	<b>-37.9</b>	<b>-37.9</b>	<b>-38.0</b>
Floor angle at maximum lift/rack back	degrees	<b>97.1</b>	<b>97.1</b>	<b>97.1</b>
Clearance at maximum lift/level bucket	mm	2943	2942	2942
	in	<b>115.9</b>	<b>115.8</b>	<b>115.8</b>
Hinge pin height at maximum lift	mm	3151	3150	3150
	in	<b>124.1</b>	<b>124.0</b>	<b>124.0</b>
Maximum overall height	mm	4062	4061	4061
	in	<b>159.9</b>	<b>159.9</b>	<b>159.9</b>
Reach at level lift arm/bucket	mm	1415	1415	1416
	in	<b>55.7</b>	<b>55.7</b>	<b>55.7</b>
Maximum floor angle at minimum lift	degrees	<b>26.6</b>	<b>26.6</b>	<b>26.6</b>
Dig depth with level bucket	mm	-11	-12	-12
	in	<b>-0.4</b>	<b>-0.5</b>	<b>-0.5</b>
Overall length with bucket on ground	mm	3739	3739	3739
	in	<b>147.2</b>	<b>147.2</b>	<b>147.2</b>
Front clearance circle radius (with bucket)	mm	2212	2244	2277
	in	<b>87.1</b>	<b>88.3</b>	<b>89.6</b>
Tipping load	kg	1940.5	1923.9	1908.4
	lb	<b>4278</b>	<b>4241</b>	<b>4207</b>
Breakout force — lift	kg	2190.6	2178.0	2168.2
	lb	<b>4829</b>	<b>4802</b>	<b>4780</b>
Breakout force — tilt	kg	3155.3	2302.8	3140.8
	lb	<b>6956</b>	<b>5077</b>	<b>6924</b>
Operating weight	kg	3400.4	3416.5	3433.8
	lb	<b>7496</b>	<b>7532</b>	<b>7570</b>

Work Tool	Pallet Fork		
Tine Length	910 mm (36")	1070 mm (42")	1220 mm (48")
Tire Size	12 x 16.5	12 x 16.5	12 x 16.5
Carriage Assembly No.	353-1694	353-1696	353-1697
Carriage overall width without step	mm	1160	1160
	in	45.7	45.7
Carriage step additional width	mm	106	106
	in	4.2	4.2
Carriage height above blade top	mm	926	926
	in	36.5	36.5
Blade surface height at maximum height	mm	3043	3043
	in	119.8	119.8
Shank front face reach at maximum height	mm	329	329
	in	12.9	13.0
Blade surface height at level lift arms	mm	1487	1486
	in	58.5	58.5
Shank front face reach at level lift arms	mm	846	847
	in	33.3	33.3
Blade surface height at minimum lift	mm	91	91
	in	3.6	3.6
Shank front face reach at minimum lift	mm	421	421
	in	16.6	16.6
Overall length at minimum lift, level tine	mm	4078	4238
	in	160.6	166.9
Tipping load	kg	1551.8	1473.4
	lb	3421	3248
Operating weight	kg	3344.5	3354.8
	lb	7373	7396

Bucket Type		General Purpose: Bolt-on Edge			
Bucket Width		1680 mm (66")	1830 mm (72")	1981 mm (78")	2134 mm (84")
Tire Size		12 x 16.5	12 x 16.5	12 x 16.5	12 x 16.5
Ground Engaging Type		Bolt-on Edge	Bolt-on Edge	Bolt-on Edge	Bolt-on Edge
Bucket Assembly No.		279-5369	279-5373	279-5377	296-8192
Rated bucket capacity	m <sup>3</sup>	0.40	0.44	0.48	0.63
	yd <sup>3</sup>	<b>0.52</b>	<b>0.58</b>	<b>0.63</b>	<b>0.82</b>
Struck capacity	m <sup>3</sup>	0.29	0.31	0.32	0.59
	yd <sup>3</sup>	<b>0.38</b>	<b>0.41</b>	<b>0.42</b>	<b>0.77</b>
Width	mm	1740	1893	2045	2198
	in	<b>68.5</b>	<b>74.5</b>	<b>80.5</b>	<b>86.5</b>
Dump clearance at maximum lift/dump	mm	2312	2312	2311	2236
	in	<b>91.0</b>	<b>91.0</b>	<b>91.0</b>	<b>88.0</b>
Reach at maximum lift/dump	mm	795	796	797	857
	in	<b>31.3</b>	<b>31.3</b>	<b>31.4</b>	<b>33.7</b>
Floor angle at maximum lift/dump	degrees	<b>-50.3</b>	<b>-50.3</b>	<b>-50.3</b>	<b>-50.4</b>
Floor angle at maximum lift/rack back	degrees	<b>84.6</b>	<b>84.6</b>	<b>84.6</b>	<b>84.6</b>
Clearance at maximum lift/level bucket	mm	2961	2960	2959	2955
	in	<b>116.6</b>	<b>116.5</b>	<b>116.5</b>	<b>116.4</b>
Hinge pin height at maximum lift	mm	3172	3171	3171	3169
	in	<b>124.9</b>	<b>124.9</b>	<b>124.8</b>	<b>124.8</b>
Maximum overall height	mm	4093	4092	4092	4183
	in	<b>161.1</b>	<b>161.1</b>	<b>161.1</b>	<b>164.7</b>
Reach at level lift arm/bucket	mm	1359	1359	1360	1455
	in	<b>53.5</b>	<b>53.5</b>	<b>53.5</b>	<b>57.3</b>
Maximum floor angle at minimum lift	degrees	<b>26.6</b>	<b>26.6</b>	<b>26.6</b>	<b>26.6</b>
Dig depth with level bucket	mm	-12	-12	-12	-15
	in	<b>-0.5</b>	<b>-0.5</b>	<b>-0.5</b>	<b>-0.6</b>
Overall length with bucket on ground	mm	3793	3793	3793	3886
	in	<b>149.3</b>	<b>149.3</b>	<b>149.3</b>	<b>153.0</b>
Front clearance circle radius (with bucket)	mm	2259	2290	2322	2436
	in	<b>88.9</b>	<b>90.1</b>	<b>91.4</b>	<b>95.9</b>
Tipping load	kg	2384.1	2366.9	2352.0	2265.3
	lb	<b>5256</b>	<b>5218</b>	<b>5185</b>	<b>4994</b>
Breakout force — lift	kg	2392.0	2378.7	2367.6	2211.6
	lb	<b>5273</b>	<b>5244</b>	<b>5220</b>	<b>4876</b>
Breakout force — tilt	kg	2947.7	2938.5	2934.4	2612.8
	lb	<b>6499</b>	<b>6478</b>	<b>6469</b>	<b>5760</b>
Operating weight	kg	3667.4	3682.9	3697.2	3734.1
	lb	<b>8085</b>	<b>8119</b>	<b>8151</b>	<b>8232</b>

Bucket Type		Multi-Purpose: Bolt-on Edge		
Bucket Width		1680 mm (66")	1830 mm (72")	1981 mm (78")
Tire Size		12 x 16.5	12 x 16.5	12 x 16.5
Ground Engaging Type		Bolt-on Edge	Bolt-on Edge	Bolt-on Edge
Bucket Assembly No.		279-5391	279-5399	279-5402
Rated bucket capacity	m <sup>3</sup>	0.34	0.37	0.40
	yd <sup>3</sup>	<b>0.44</b>	<b>0.48</b>	<b>0.52</b>
Struck capacity	m <sup>3</sup>	0.25	0.26	0.28
	yd <sup>3</sup>	<b>0.33</b>	<b>0.34</b>	<b>0.37</b>
Width	mm	1749	1902	2045
	in	<b>68.9</b>	<b>74.9</b>	<b>80.5</b>
Dump clearance at maximum lift/dump	mm	2298	2297	2296
	in	<b>90.5</b>	<b>90.4</b>	<b>90.4</b>
Reach at maximum lift/dump	mm	803	804	805
	in	<b>31.6</b>	<b>31.7</b>	<b>31.7</b>
Floor angle at maximum lift/dump	degrees	<b>-50.5</b>	<b>-50.5</b>	<b>-50.5</b>
Floor angle at maximum lift/rack back	degrees	<b>84.5</b>	<b>84.5</b>	<b>84.4</b>
Clearance at maximum lift/level bucket	mm	2952	2951	2950
	in	<b>116.2</b>	<b>116.2</b>	<b>116.1</b>
Hinge pin height at maximum lift	mm	3166	3166	3165
	in	<b>124.7</b>	<b>124.6</b>	<b>124.6</b>
Maximum overall height	mm	4095	4094	4093
	in	<b>161.2</b>	<b>161.2</b>	<b>161.1</b>
Reach at level lift arm/bucket	mm	1370	1371	1371
	in	<b>53.9</b>	<b>54.0</b>	<b>54.0</b>
Maximum floor angle at minimum lift	degrees	<b>26.6</b>	<b>26.6</b>	<b>26.6</b>
Dig depth with level bucket	mm	-18	-19	-19
	in	<b>-0.7</b>	<b>-0.7</b>	<b>-0.8</b>
Overall length with bucket on ground	mm	3799	3799	3799
	in	<b>149.6</b>	<b>149.6</b>	<b>149.6</b>
Front clearance circle radius (with bucket)	mm	2262	2292	2325
	in	<b>89.1</b>	<b>90.2</b>	<b>91.5</b>
Tipping load	kg	2228.5	2205.9	2196.5
	lb	<b>4913</b>	<b>4863</b>	<b>4842</b>
Breakout force — lift	kg	2282.1	2263.6	2246.7
	lb	<b>5031</b>	<b>4990</b>	<b>4953</b>
Breakout force — tilt	kg	2885.9	2876.2	2865.1
	lb	<b>6362</b>	<b>6341</b>	<b>6316</b>
Operating weight	kg	3800.8	3823.6	3843.5
	lb	<b>8379</b>	<b>8430</b>	<b>8473</b>

Bucket Type		Dirt: Bolt-on Edge		
Bucket Width		1680 mm (66")	1830 mm (72")	1981 mm (78")
Tire Size		12 x 16.5	12 x 16.5	12 x 16.5
Ground Engaging Type		Bolt-on Edge	Bolt-on Edge	Bolt-on Edge
Bucket Assembly No.		279-5441	285-6090	268-4083
Rated bucket capacity	m <sup>3</sup>	0.37	0.41	0.44
	yd <sup>3</sup>	<b>0.48</b>	<b>0.54</b>	<b>0.58</b>
Struck capacity	m <sup>3</sup>	0.27	0.30	0.32
	yd <sup>3</sup>	<b>0.35</b>	<b>0.39</b>	<b>0.42</b>
Width	mm	1740	1893	2045
	in	<b>68.5</b>	<b>74.5</b>	<b>80.5</b>
Dump clearance at maximum lift/dump	mm	2356	2355	2354
	in	<b>92.7</b>	<b>92.7</b>	<b>92.7</b>
Reach at maximum lift/dump	mm	762	763	764
	in	<b>30.0</b>	<b>30.0</b>	<b>30.1</b>
Floor angle at maximum lift/dump	degrees	<b>-50.3</b>	<b>-50.3</b>	<b>-50.3</b>
Floor angle at maximum lift/rack back	degrees	<b>84.7</b>	<b>84.6</b>	<b>84.6</b>
Clearance at maximum lift/level bucket	mm	2964	2963	2963
	in	<b>116.7</b>	<b>116.7</b>	<b>116.6</b>
Hinge pin height at maximum lift	mm	3173	3172	3171
	in	<b>124.9</b>	<b>124.9</b>	<b>124.9</b>
Maximum overall height	mm	4042	4041	4040
	in	<b>159.1</b>	<b>159.1</b>	<b>159.1</b>
Reach at level lift arm/bucket	mm	1305	1306	1306
	in	<b>51.4</b>	<b>51.4</b>	<b>51.4</b>
Maximum floor angle at minimum lift	degrees	<b>26.6</b>	<b>26.6</b>	<b>26.6</b>
Dig depth with level bucket	mm	-9	-9	-10
	in	<b>-0.3</b>	<b>-0.4</b>	<b>-0.4</b>
Overall length with bucket on ground	mm	3740	3740	3740
	in	<b>147.2</b>	<b>147.2</b>	<b>147.2</b>
Front clearance circle radius (with bucket)	mm	2212	2244	2277
	in	<b>87.1</b>	<b>88.3</b>	<b>89.6</b>
Tipping load	kg	2467.9	2451.6	2436.5
	lb	<b>5441</b>	<b>5405</b>	<b>5371</b>
Breakout force — lift	kg	2450.5	2436.5	2423.0
	lb	<b>5402</b>	<b>5372</b>	<b>5342</b>
Breakout force — tilt	kg	3155.8	3146.0	3141.2
	lb	<b>6957</b>	<b>6936</b>	<b>6925</b>
Operating weight	kg	3644.7	3660.8	3678.1
	lb	<b>8035</b>	<b>8071</b>	<b>8109</b>

Work Tool	Pallet Fork		
Tine Length	910 mm (36")	1070 mm (42")	1220 mm (48")
Tire Size	12 x 16.5	12 x 16.5	12 x 16.5
Carriage Assembly No.	353-1694	353-1696	353-1697
Carriage overall width without step	mm	1160	1160
	in	45.7	45.7
Carriage step additional width	mm	106	106
	in	4.2	4.2
Carriage height above blade top	mm	926	926
	in	36.5	36.5
Blade surface height at maximum height	mm	3158	3158
	in	124.3	124.3
Shank front face reach at maximum height	mm	672	673
	in	26.5	26.5
Blade surface height at level lift arms	mm	1495	1495
	in	58.9	58.8
Shank front face reach at level lift arms	mm	736	736
	in	29.0	29.0
Blade surface height at minimum lift	mm	91	91
	in	3.6	3.6
Shank front face reach at minimum lift	mm	421	421
	in	16.6	16.6
Overall length at minimum lift, level tine	mm	4078	4238
	in	160.6	166.9
Tipping load	kg	1941.0	1841.8
	lb	4279	4060
Operating weight	kg	3588.8	3599.1
	lb	7912	7935
			7956

Bucket Type		General Purpose: Bolt-on Edge		
Bucket Width		1830 mm (72")	1981 mm (78")	2134 mm (84")
Tire Size		12 x 16.5	12 x 16.5	12 x 16.5
Ground Engaging Type		Bolt-on Edge	Bolt-on Edge	Bolt-on Edge
Bucket Assembly No.		279-5373	279-5377	296-8192
Rated bucket capacity	m <sup>3</sup>	0.44	0.48	0.63
	yd <sup>3</sup>	<b>0.58</b>	<b>0.63</b>	<b>0.82</b>
Struck capacity	m <sup>3</sup>	0.31	0.32	0.59
	yd <sup>3</sup>	<b>0.41</b>	<b>0.42</b>	<b>0.77</b>
Width	mm	1893	2045	2198
	in	<b>74.5</b>	<b>80.5</b>	<b>86.5</b>
Dump clearance at maximum lift/dump	mm	2360	2360	2284
	in	<b>92.9</b>	<b>92.9</b>	<b>89.9</b>
Reach at maximum lift/dump	mm	808	809	868
	in	<b>31.8</b>	<b>31.9</b>	<b>34.2</b>
Floor angle at maximum lift/dump	degrees	-51.1	-51.1	-51.1
Floor angle at maximum lift/rack back	degrees	<b>83.1</b>	<b>83.9</b>	<b>83.9</b>
Clearance at maximum lift/level bucket	mm	3027	3026	3023
	in	<b>119.2</b>	<b>119.1</b>	<b>119.0</b>
Hinge pin height at maximum lift	mm	3227	3226	3225
	in	<b>127.1</b>	<b>127.0</b>	<b>127.0</b>
Maximum overall height	mm	4139	4142	4233
	in	<b>162.9</b>	<b>163.1</b>	<b>166.7</b>
Reach at level lift arm/bucket	mm	1365	1365	1459
	in	<b>53.7</b>	<b>53.7</b>	<b>57.5</b>
Maximum floor angle at minimum lift	degrees	<b>28.4</b>	<b>28.4</b>	<b>28.3</b>
Dig depth with level bucket	mm	-5	-6	-8
	in	<b>-0.2</b>	<b>-0.2</b>	<b>-0.3</b>
Overall length with bucket on ground	mm	4042	4042	4134
	in	<b>159.1</b>	<b>159.1</b>	<b>162.8</b>
Front clearance circle radius (with bucket)	mm	2355	2387	2495
	in	<b>92.7</b>	<b>94.0</b>	<b>98.2</b>
Tipping load	kg	2910.9	2895.5	2799.3
	lb	<b>6417</b>	<b>6383</b>	<b>6171</b>
Breakout force — lift	kg	2631.7	2620.5	2517.3
	lb	<b>5802</b>	<b>5777</b>	<b>5550</b>
Breakout force — tilt	kg	2896.0	2887.8	2650.3
	lb	<b>6384</b>	<b>6366</b>	<b>5843</b>
Operating weight	kg	4056.1	4070.4	4107.3
	lb	<b>8942</b>	<b>8974</b>	<b>9055</b>

Bucket Type		Multi-Purpose: Bolt-on Edge		Dirt: Bolt-on Edge	
Bucket Width		1830 mm (72")	1981 mm (78")	1830 mm (72")	1981 mm (78")
Tire Size		12 x 16.5	12 x 16.5	12 x 16.5	12 x 16.5
Ground Engaging Type		Bolt-on Edge	Bolt-on Edge	Bolt-on Edge	Bolt-on Edge
Bucket Assembly No.		279-5399	279-5402	285-6090	268-4083
Rated bucket capacity	m <sup>3</sup>	0.37	0.40	0.41	0.44
	yd <sup>3</sup>	<b>0.48</b>	<b>0.52</b>	<b>0.54</b>	<b>0.58</b>
Struck capacity	m <sup>3</sup>	0.26	0.28	0.30	0.32
	yd <sup>3</sup>	<b>0.34</b>	<b>0.37</b>	<b>0.39</b>	<b>0.42</b>
Width	mm	1902	2045	1893	2045
	in	<b>74.9</b>	<b>80.5</b>	<b>74.5</b>	<b>80.5</b>
Dump clearance at maximum lift/dump	mm	2346	2346	2404	2403
	in	<b>92.4</b>	<b>92.3</b>	<b>94.6</b>	<b>94.6</b>
Reach at maximum lift/dump	mm	816	817	776	777
	in	<b>32.1</b>	<b>32.2</b>	<b>30.6</b>	<b>30.6</b>
Floor angle at maximum lift/dump	degrees	<b>-51.2</b>	<b>-51.3</b>	<b>-51.0</b>	<b>-51.1</b>
Floor angle at maximum lift/rack back	degrees	<b>83.8</b>	<b>83.8</b>	<b>83.9</b>	<b>83.9</b>
Clearance at maximum lift/level bucket	mm	3015	3014	3030	3029
	in	<b>118.7</b>	<b>118.7</b>	<b>119.3</b>	<b>119.2</b>
Hinge pin height at maximum lift	mm	3223	3222	3228	3227
	in	<b>126.9</b>	<b>126.8</b>	<b>127.1</b>	<b>127.1</b>
Maximum overall height	mm	4144	4143	4091	4090
	in	<b>163.2</b>	<b>163.1</b>	<b>161.1</b>	<b>161.0</b>
Reach at level lift arm/bucket	mm	1375	1375	1356	1312
	in	<b>54.1</b>	<b>54.1</b>	<b>53.4</b>	<b>51.6</b>
Maximum floor angle at minimum lift	degrees	<b>28.2</b>	<b>28.2</b>	<b>28.4</b>	<b>28.4</b>
Dig depth with level bucket	mm	-15	-16	-2	-3
	in	<b>-0.6</b>	<b>-0.6</b>	<b>-0.1</b>	<b>-0.1</b>
Overall length with bucket on ground	mm	4048	4047	3989	3989
	in	<b>159.4</b>	<b>159.3</b>	<b>157.0</b>	<b>157.0</b>
Front clearance circle radius (with bucket)	mm	2362	2394	2311	2344
	in	<b>93.0</b>	<b>94.2</b>	<b>91.0</b>	<b>92.3</b>
Tipping load	kg	2742.2	2735.3	3008.3	2993.3
	lb	<b>6045</b>	<b>6030</b>	<b>6632</b>	<b>6599</b>
Breakout force — lift	kg	2515.7	2498.7	2691.8	2678.1
	lb	<b>5546</b>	<b>5509</b>	<b>5934</b>	<b>5904</b>
Breakout force — tilt	kg	2801.6	2786.7	3028.1	3018.2
	lb	<b>6176</b>	<b>6144</b>	<b>6676</b>	<b>6654</b>
Operating weight	kg	4196.8	4216.7	4034.0	4051.3
	lb	<b>9252</b>	<b>9296</b>	<b>8893</b>	<b>8931</b>



Work Tool		Pallet Fork		
Tine Length		910 mm (36")	1070 mm (42")	1220 mm (48")
Tire Size		12 x 16.5	12 x 16.5	12 x 16.5
Carriage Assembly No.		353-1694	353-1696	353-1697
Carriage overall width without step	mm	1160	1160	1160
	in	<b>45.7</b>	<b>45.7</b>	<b>45.7</b>
Carriage step additional width	mm	106	106	106
	in	<b>4.2</b>	<b>4.2</b>	<b>4.2</b>
Carriage height above blade top	mm	926	926	926
	in	<b>36.5</b>	<b>36.5</b>	<b>36.5</b>
Blade surface height at maximum height	mm	3128	3140	3140
	in	<b>123.1</b>	<b>123.6</b>	<b>123.6</b>
Shank front face reach at maximum height	mm	709	700	701
	in	<b>27.9</b>	<b>27.5</b>	<b>27.6</b>
Blade surface height at level lift arms	mm	1454	1466	1466
	in	<b>57.2</b>	<b>57.7</b>	<b>57.7</b>
Shank front face reach at level lift arms	mm	751	741	742
	in	<b>29.6</b>	<b>29.2</b>	<b>29.2</b>
Blade surface height at minimum lift	mm	105	107	108
	in	<b>4.1</b>	<b>4.2</b>	<b>4.2</b>
Shank front face reach at minimum lift	mm	443	443	444
	in	<b>17.4</b>	<b>17.4</b>	<b>17.5</b>
Overall length at minimum lift, level tine	mm	4331	4491	4641
	in	<b>170.5</b>	<b>176.8</b>	<b>182.7</b>
Tipping load	kg	2369.1	2250.3	2147.7
	lb	<b>5223</b>	<b>4961</b>	<b>4735</b>
Operating weight	kg	3962.0	3972.3	3981.9
	lb	<b>8735</b>	<b>8757</b>	<b>8778</b>

Bucket Type		General Purpose: Bolt-on Edge		
		1830 mm (72")	1981 mm (78")	2134 mm (84")
Bucket Width		1830 mm (72")	1981 mm (78")	2134 mm (84")
Tire Size		14 x 17.5	14 x 17.5	14 x 17.5
Ground Engaging Type		Bolt-on Edge	Bolt-on Edge	Bolt-on Edge
Bucket Assembly No.		279-5373	279-5377	296-8192
Rated bucket capacity	m <sup>3</sup>	0.44	0.48	0.63
	yd <sup>3</sup>	0.58	0.63	0.82
Struck capacity	m <sup>3</sup>	0.31	0.32	0.59
	yd <sup>3</sup>	0.41	0.42	0.77
Width	mm	1893	2045	2198
	in	74.5	80.5	86.5
Dump clearance at maximum lift/dump	mm	2397	2397	2322
	in	94.4	94.4	91.4
Reach at maximum lift/dump	mm	774	774	833
	in	30.5	30.5	32.8
Floor angle at maximum lift/dump	degrees	-51.2	-51.2	-51.2
Floor angle at maximum lift/rack back	degrees	83.8	83.8	83.8
Clearance at maximum lift/level bucket	mm	3063	3063	3059
	in	120.6	120.6	120.5
Hinge pin height at maximum lift	mm	3265	3264	3263
	in	128.5	128.5	128.5
Maximum overall height	mm	4180	4179	4271
	in	164.6	164.5	168.1
Reach at level lift arm/bucket	mm	1328	1329	1423
	in	52.3	52.3	56.0
Maximum floor angle at minimum lift	degrees	27.6	27.5	27.5
Dig depth with level bucket	mm	-2	-2	-5
	in	-0.1	-0.1	-0.2
Overall length with bucket on ground	mm	4025	4025	4118
	in	158.5	158.5	162.1
Front clearance circle radius (with bucket)	mm	2345	2375	2484
	in	92.3	93.5	97.8
Tipping load	kg	3118.7	3103.1	3003.0
	lb	6876	6841	6621
Breakout force — lift	kg	2646.2	2635.0	2531.1
	lb	5834	5809	5580
Breakout force — tilt	kg	2949.5	2945.4	2622.6
	lb	6502	6493	5782
Operating weight	kg	4242.8	4257.1	4294.0
	lb	9354	9385	9467

Bucket Type		Multi-Purpose: Bolt-on Edge		Dirt: Bolt-on Edge	
Bucket Width		1830 mm (72")	1981 mm (78")	1830 mm (72")	1981 mm (78")
Tire Size		14 x 17.5	14 x 17.5	14 x 17.5	14 x 17.5
Ground Engaging Type		Bolt-on Edge	Bolt-on Edge	Bolt-on Edge	Bolt-on Edge
Bucket Assembly No.		279-5399	279-5402	285-6090	268-4083
Rated bucket capacity	m <sup>3</sup>	0.37	0.40	0.41	0.44
	yd <sup>3</sup>	<b>0.48</b>	<b>0.52</b>	<b>0.54</b>	<b>0.58</b>
Struck capacity	m <sup>3</sup>	0.26	0.28	0.30	0.32
	yd <sup>3</sup>	<b>0.34</b>	<b>0.37</b>	<b>0.39</b>	<b>0.42</b>
Width	mm	1902	2045	1893	2045
	in	<b>74.9</b>	<b>80.5</b>	<b>74.5</b>	<b>80.5</b>
Dump clearance at maximum lift/dump	mm	2385	2384	2441	2440
	in	<b>93.9</b>	<b>93.9</b>	<b>96.1</b>	<b>96.1</b>
Reach at maximum lift/dump	mm	780	781	742	742
	in	<b>30.7</b>	<b>30.8</b>	<b>29.2</b>	<b>29.2</b>
Floor angle at maximum lift/dump	degrees	<b>-51.3</b>	<b>-51.3</b>	<b>-51.1</b>	<b>-51.2</b>
Floor angle at maximum lift/rack back	degrees	<b>83.7</b>	<b>83.7</b>	<b>83.8</b>	<b>83.8</b>
Clearance at maximum lift/level bucket	mm	3053	3052	3066	3065
	in	<b>120.2</b>	<b>120.2</b>	<b>120.7</b>	<b>120.7</b>
Hinge pin height at maximum lift	mm	3261	3260	3265	3265
	in	<b>128.4</b>	<b>128.4</b>	<b>128.6</b>	<b>128.5</b>
Maximum overall height	mm	4182	4181	4128	4128
	in	<b>164.7</b>	<b>164.6</b>	<b>162.5</b>	<b>162.5</b>
Reach at level lift arm/bucket	mm	1338	1338	1275	1275
	in	<b>52.7</b>	<b>52.7</b>	<b>50.2</b>	<b>50.2</b>
Maximum floor angle at minimum lift	degrees	<b>27.4</b>	<b>27.4</b>	<b>27.6</b>	<b>27.6</b>
Dig depth with level bucket	mm	-10	-11	1	0
	in	<b>-0.4</b>	<b>-0.4</b>	<b>0.0</b>	<b>0.0</b>
Overall length with bucket on ground	mm	4031	4031	3972	3972
	in	<b>158.7</b>	<b>158.7</b>	<b>156.4</b>	<b>156.4</b>
Front clearance circle radius (with bucket)	mm	2350	2382	2299	2332
	in	<b>92.5</b>	<b>93.8</b>	<b>90.5</b>	<b>91.8</b>
Tipping load	kg	2946.8	2941.4	3223.3	3208.3
	lb	<b>6497</b>	<b>6485</b>	<b>7106</b>	<b>7073</b>
Breakout force — lift	kg	2530.3	2513.3	2706.7	2693.0
	lb	<b>5578</b>	<b>5541</b>	<b>5967</b>	<b>5937</b>
Breakout force — tilt	kg	2887.2	2876.1	3157.8	3153.0
	lb	<b>6365</b>	<b>6341</b>	<b>6962</b>	<b>6951</b>
Operating weight	kg	4383.5	4403.4	4220.7	4238.0
	lb	<b>9664</b>	<b>9708</b>	<b>9305</b>	<b>9343</b>

Work Tool	Pallet Fork		
	910 mm (36")	1070 mm (42")	1220 mm (48")
<b>Tine Length</b>	<b>910 mm (36")</b>	<b>1070 mm (42")</b>	<b>1220 mm (48")</b>
<b>Tire Size</b>	<b>14 x 17.5</b>	<b>14 x 17.5</b>	<b>14 x 17.5</b>
<b>Carriage Assembly No.</b>	<b>353-1694</b>	<b>353-1696</b>	<b>353-1697</b>
Carriage overall width without step	mm	1160	1160
	in	<b>45.7</b>	<b>45.7</b>
Carriage step additional width	mm	106	106
	in	<b>4.2</b>	<b>4.2</b>
Carriage height above blade top	mm	926	926
	in	<b>36.5</b>	<b>36.5</b>
Blade surface height at maximum height	mm	3173	3174
	in	<b>124.9</b>	<b>125.0</b>
Shank front face reach at maximum height	mm	666	667
	in	<b>26.2</b>	<b>26.3</b>
Blade surface height at level lift arms	mm	1499	1500
	in	<b>59.0</b>	<b>59.1</b>
Shank front face reach at level lift arms	mm	705	705
	in	<b>27.7</b>	<b>27.8</b>
Blade surface height at minimum lift	mm	107	109
	in	<b>4.2</b>	<b>4.3</b>
Shank front face reach at minimum lift	mm	389	389
	in	<b>15.3</b>	<b>15.3</b>
Overall length at minimum lift, level tine	mm	4314	4474
	in	<b>169.9</b>	<b>176.2</b>
Tipping load	kg	2511.5	2384.9
	lb	<b>5537</b>	<b>5258</b>
Operating weight	kg	4148.7	4159.0
	lb	<b>9146</b>	<b>9169</b>

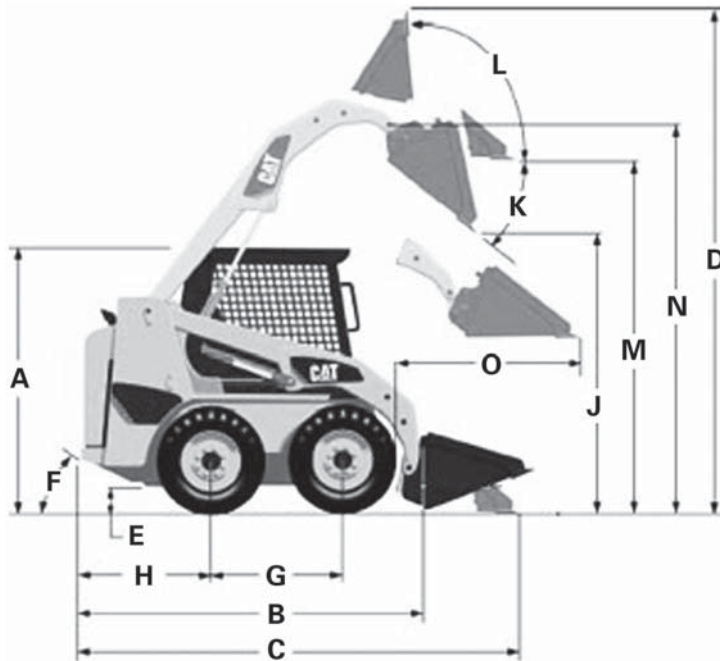

MODEL	216B3		226B3	
Rated operating capacity*	635 kg	1400 lb	680 kg	1500 lb
A Height to top of ROPS	1950 mm	6'5"	1950 mm	6'5"
B Length to coupler	2519 mm	8'3"	2519 mm	8'3"
C Length with bucket on ground	3233 mm	10'7"	3233 mm	10'7"
D Maximum overall height	3709 mm	12'2"	3709 mm	12'2"
E Ground clearance	195 mm	8"	195 mm	8"
F Departure angle		26°		26°
G Wheelbase	986 mm	3'3"	986 mm	3'3"
H Bumper overhang from axle	967 mm	3'2"	967 mm	3'2"
Bucket overall width	1524 mm	5'2"	1524 mm	5'2"
J Clearance at maximum lift/dump	2169 mm	7'1"	2169 mm	7'1"
K Floor angle at maximum lift/dump		40°		40°
L Floor angle at maximum lift/rack		96.7°		96.7°
M Clearance at maximum lift/level	2661 mm	8'9"	2661 mm	8'9"
N Hinge pin height at maximum lift	2854 mm	9'4"	2854 mm	9'4"
O Reach at level lift arm/bucket	1280 mm	4'2"	1280 mm	4'2"
Hinge pin height at carry position	239 mm	9.3"	239 mm	9.3"
Maximum floor angle at carry position		27.7°		27.7°

\*SAE J818 MAY87, ISO 5998:1986.

NOTE: 216B3/226B3 machine dimensions shown with standard machine equipped with optional 10 x 16.5 10 PR tires and 1520 mm (60") dirt bucket.

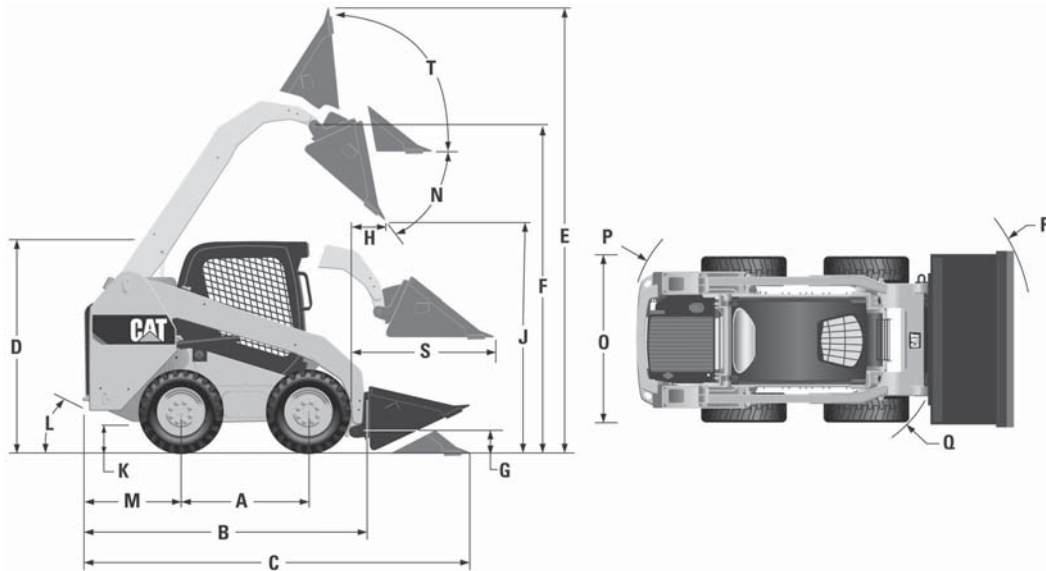

MODEL	226D		232D	
Operating weight	2588 kg	<b>5705 lb</b>	2818 kg	<b>6213 lb</b>
Rated operating capacity	703 kg	<b>1550 lb</b>	839 kg	<b>1850 lb</b>
Tipping load	1407 kg	<b>3100 lb</b>	1679 kg	<b>3700 lb</b>
Breakout force, tilt cylinder	1807 kg	<b>3983 lb</b>	1807 kg	<b>3983 lb</b>
A Wheelbase	1054 mm	<b>41.5"</b>	1054 mm	<b>41.5"</b>
B Length without bucket	2524 mm	<b>99.4"</b>	2523 mm	<b>99.3"</b>
C Length with bucket on ground	3234 mm	<b>127.3"</b>	3233 mm	<b>127.3"</b>
D Height to top of cab	2028 mm	<b>79.8"</b>	2029 mm	<b>79.9"</b>
E Maximum overall height	3652 mm	<b>143.8"</b>	3832 mm	<b>150.9"</b>
F Bucket pin height at maximum lift	2818 mm	<b>110.9"</b>	3001 mm	<b>118.1"</b>
G Bucket pin height at carry position	215 mm	<b>8.5"</b>	214 mm	<b>8.4"</b>
H Reach at maximum lift and dump	533 mm	<b>21.0"</b>	653 mm	<b>25.7"</b>
J Clearance at maximum lift and dump	2077 mm	<b>81.8"</b>	2254 mm	<b>88.7"</b>
K Ground clearance	175 mm	<b>6.9"</b>	170 mm	<b>6.7"</b>
L Departure angle		<b>28°</b>		<b>28°</b>
M Bumper overhang behind rear axle	894 mm	<b>35.2"</b>	894 mm	<b>35.2"</b>
N Maximum dump angle		<b>47°</b>		<b>47°</b>
O Vehicle width over tires	1497 mm	<b>58.9"</b>	1497 mm	<b>58.9"</b>
P Turning radius from center — machine rear	1513 mm	<b>59.6"</b>	1513 mm	<b>59.6"</b>
Q Turning radius from center — coupler	1104 mm	<b>43.5"</b>	1102 mm	<b>43.4"</b>
R Turning radius from center — bucket	1977 mm	<b>77.8"</b>	1976 mm	<b>77.8"</b>
S Maximum reach with arms parallel to ground	1288 mm	<b>50.7"</b>	1249 mm	<b>49.2"</b>
T Rack back angle at maximum height		<b>88.9°</b>		<b>88.2°</b>
Bucket pin reach at maximum lift	2818 mm	<b>110.9"</b>	3001 mm	<b>118.1"</b>

**NOTE:** Based on 75 kg (165 lb) operator, all fluids, one speed, OROPS, 1524 mm (60") dirt bucket, Cat 10 x 16.5 tires, standard flow hydraulics, mechanical suspension seat, no optional counterweights and manual quick coupler (unless otherwise noted).

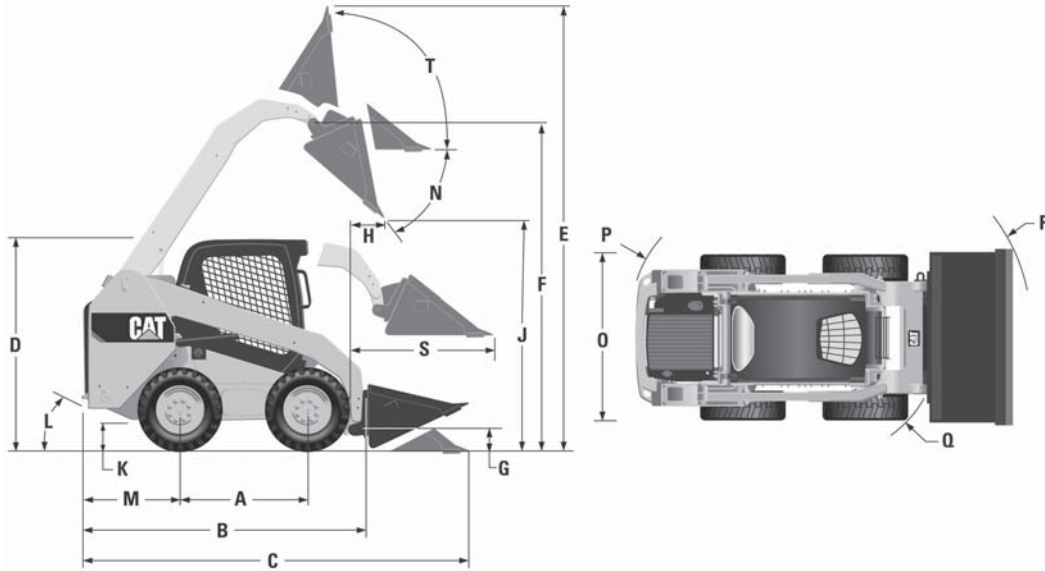

MODEL	236D		242D		246D	
	(10 x 16.5 tires)					
Operating weight	2975 kg	<b>6559 lb</b>	3166 kg	<b>6980 lb</b>	3368 kg	<b>7424 lb</b>
Rated operating capacity	818 kg	<b>1800 lb</b>	975 kg	<b>2150 lb</b>	975 kg	<b>2150 lb</b>
Tipping load	1633 kg	<b>3600 lb</b>	1950 kg	<b>4300 lb</b>	1950 kg	<b>4300 lb</b>
Breakout force, tilt cylinder	2302 kg	<b>5074 lb</b>	2283 kg	<b>5034 lb</b>	3336 kg	<b>7355 lb</b>
A Wheelbase	1105 mm	<b>43.5"</b>	1105 mm	<b>43.5"</b>	1249 mm	<b>49.2"</b>
B Length without bucket	2767 mm	<b>108.9"</b>	2767 mm	<b>108.9"</b>	2993 mm	<b>117.8"</b>
C Length with bucket on ground	3487 mm	<b>137.3"</b>	3487 mm	<b>137.3"</b>	3708 mm	<b>146.0"</b>
D Height to top of cab	2082 mm	<b>82.0"</b>	2111 mm	<b>83.1"</b>	2110 mm	<b>83.1"</b>
E Maximum overall height	3977 mm	<b>156.6"</b>	3917 mm	<b>154.2"</b>	4032 mm	<b>158.7"</b>
F Bucket pin height at maximum lift	3122 mm	<b>122.9"</b>	3076 mm	<b>121.1"</b>	3154 mm	<b>124.2"</b>
G Bucket pin height at carry position	190 mm	<b>7.5"</b>	200 mm	<b>7.9"</b>	200 mm	<b>7.9"</b>
H Reach at maximum lift and dump	408 mm	<b>16.0"</b>	552 mm	<b>21.7"</b>	600 mm	<b>23.6"</b>
J Clearance at maximum lift and dump	2359 mm	<b>92.9"</b>	2285 mm	<b>90.0"</b>	2465 mm	<b>97.1"</b>
K Ground clearance	195 mm	<b>7.7"</b>	222 mm	<b>8.7"</b>	226 mm	<b>8.9"</b>
L Departure angle		<b>26°</b>		<b>27°</b>		<b>26°</b>
M Bumper overhang behind rear axle	1021 mm	<b>40.2"</b>	1021 mm	<b>40.2"</b>	1083 mm	<b>42.6"</b>
N Maximum dump angle		<b>48°</b>		<b>52°</b>		<b>39°</b>
O Vehicle width over tires	1676 mm	<b>66.0"</b>	1675 mm	<b>66.0"</b>	1676 mm	<b>66.0"</b>
P Turning radius from center — machine rear	1639 mm	<b>64.5"</b>	1639 mm	<b>64.5"</b>	1806 mm	<b>71.2"</b>
Q Turning radius from center — coupler	1314 mm	<b>51.8"</b>	1314 mm	<b>51.8"</b>	1401 mm	<b>55.2"</b>
R Turning radius from center — bucket	2107 mm	<b>83.0"</b>	2107 mm	<b>83.0"</b>	2181 mm	<b>85.9"</b>
S Maximum reach with arms parallel to ground	1353 mm	<b>53.3"</b>	1249 mm	<b>49.2"</b>	1388 mm	<b>54.6"</b>
T Rack back angle at maximum height		<b>91°</b>		<b>87°</b>		<b>96°</b>
Bucket pin reach at maximum lift		—	182 mm	<b>7.2"</b>		—

NOTE: Based on 75 kg (165 lb) operator, all fluids, one speed, OROPS, 1676 mm (66") dirt bucket, Cat 12 x 16.5 tires, standard flow hydraulics, mechanical suspension seat, no optional counterweights and manual quick coupler (unless otherwise noted).

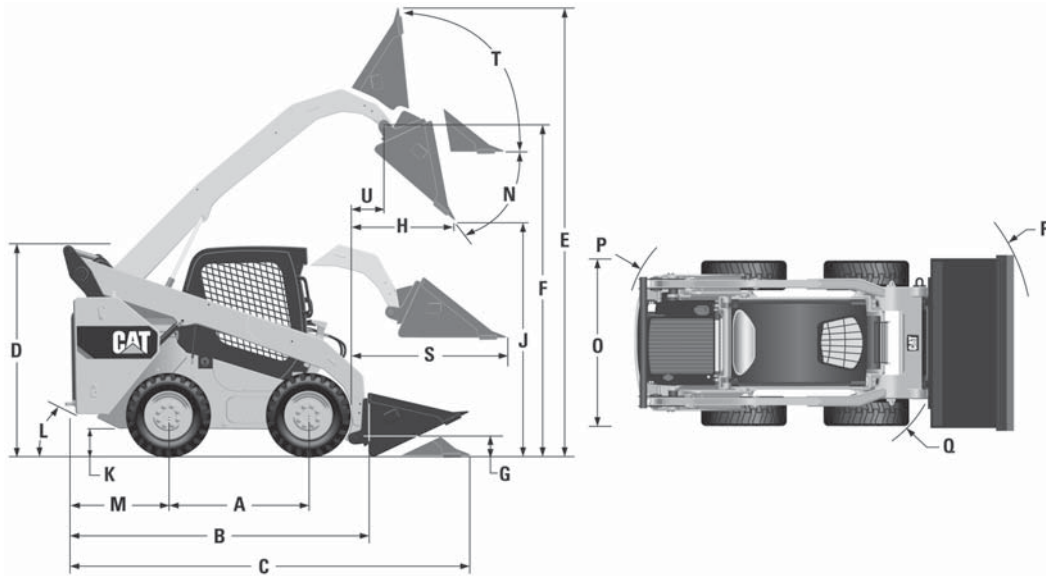

MODEL	262D		272D2		272D2 XHP	
Operating weight	3634 kg	<b>8011 lb</b>	3977 kg	<b>8768 lb</b>	4198 kg	<b>9255 lb</b>
Rated operating capacity	1225 kg	<b>2700 lb</b>	1542 kg	<b>3400 lb</b>	1656 kg	<b>3650 lb</b>
Tipping load	2449 kg	<b>5400 lb</b>	3084 kg	<b>6800 lb</b>	3311 kg	<b>7300 lb</b>
Breakout force, tilt cylinder	3336 kg	<b>7355 lb</b>	3336 kg	<b>7443 lb</b>	3339 kg	<b>7362 lb</b>
A Wheelbase	1249 mm	<b>49.2"</b>	1386 mm	<b>54.6"</b>	1386 mm	<b>54.6"</b>
B Length without bucket	2995 mm	<b>117.9"</b>	3242 mm	<b>127.6"</b>	3226 mm	<b>127.0"</b>
C Length with bucket on ground	3714 mm	<b>146.2"</b>	3954 mm	<b>155.7"</b>	3937 mm	<b>155.0"</b>
D Height to top of cab	2110 mm	<b>83.1"</b>	2094 mm	<b>82.4"</b>	2133 mm	<b>84.0"</b>
E Maximum overall height	4008 mm	<b>157.8"</b>	4067 mm	<b>160.1"</b>	4103 mm	<b>161.5"</b>
F Bucket pin height at maximum lift	3172 mm	<b>124.9"</b>	3229 mm	<b>127.1"</b>	3265 mm	<b>128.6"</b>
G Bucket pin height at carry position	200 mm	<b>7.9"</b>	198 mm	<b>7.8"</b>	235 mm	<b>9.3"</b>
H Reach at maximum lift and dump	786 mm	<b>30.9"</b>	769 mm	<b>30.3"</b>	736 mm	<b>29.0"</b>
J Clearance at maximum lift and dump	2380 mm	<b>93.7"</b>	2438 mm	<b>96.0"</b>	2474 mm	<b>97.4"</b>
K Ground clearance	226 mm	<b>8.9"</b>	226 mm	<b>8.9"</b>	263 mm	<b>10.4"</b>
L Departure angle		<b>26°</b>		<b>27°</b>		<b>28°</b>
M Bumper overhang behind rear axle	1083 mm	<b>42.6"</b>	1175 mm	<b>46.2"</b>	1175 mm	<b>46.2"</b>
N Maximum dump angle		<b>51°</b>		<b>51°</b>		<b>51°</b>
O Vehicle width over tires	1676 mm	<b>66.0"</b>	1829 mm	<b>72.0"</b>	1930 mm	<b>76.0"</b>
P Turning radius from center — machine rear	1805 mm	<b>71.1"</b>	1899 mm	<b>74.7"</b>	1899 mm	<b>74.7"</b>
Q Turning radius from center — coupler	1401 mm	<b>55.2"</b>	1482 mm	<b>58.3"</b>	1466 mm	<b>57.7"</b>
R Turning radius from center — bucket	2181 mm	<b>85.9"</b>	2280 mm	<b>89.8"</b>	2301 mm	<b>90.6"</b>
S Maximum reach with arms parallel to ground	1293 mm	<b>50.9"</b>	1282 mm	<b>50.5"</b>	1246 mm	<b>49.1"</b>
T Rack back angle at maximum height		<b>84°</b>		<b>84°</b>		<b>84°</b>
U Bucket pin reach at maximum lift	393 mm	<b>15.5"</b>	374 mm	<b>14.7"</b>	344 mm	<b>13.5"</b>

**NOTE:** 262D based on 75 kg (165 lb) operator, all fluids, one speed, OROPS, standard flow hydraulics, mechanical suspension seat, no optional counterweights and manual quick coupler (unless otherwise noted). 262D based on 1676 mm (66") dirt bucket and Cat 12 x 16.5 tires.

**NOTE:** 272D2 based on 75 kg (165 lb) operator, all fluids, one speed, C2 enclosed cab with heat, glass door, standard flow hydraulics, mechanical suspension seat, no optional counterweights and manual quick coupler (unless otherwise noted), 1829 mm (72") dirt bucket and Cat 12 x 16.5 tires.

**NOTE:** 272D2 XHP based on 75 kg (165 lb) operator, all fluids, one speed, C3 enclosed cab with A/C, glass door, standard flow hydraulics, mechanical suspension seat, no optional counterweights and manual quick coupler (unless otherwise noted), 1981 mm (78") dirt bucket and Cat 14 x 17.5 tires.



**CAT WORK TOOL COMPATIBILITY**

	216B3	226B3	226D	232D	236D	242D	246D	262D	272D2	272D2 XHP
<b>General Purpose Buckets</b>										
1524 mm (60")	C	C	C	C	C	C	C	C	C	C
1676 mm (66")	C	C	C	C	C	C	C	C	C	C
1829 mm (72")	C	C	C	C	C	C	C	C	C	C
1981 mm (78")	C	C	C	C	C	C	C	C	C	C
<b>High Capacity Bucket (GP)</b>										
2134 mm (84")	C	C	C	C	C	C	C	C	C	C
<b>Dirt Buckets</b>										
1372 mm (54")	C	C	C	C	C	C	C	C	C	C
1524 mm (60")	C	C	C	C	C	C	C	C	C	C
1676 mm (66")	C	C	C	C	C	C	C	C	C	C
1829 mm (72")	C	C	C	C	C	C	C	C	C	C
1981 mm (78")	C	C	C	C	C	C	C	C	C	C
<b>Utility Buckets</b>										
1524 mm (60")	C	C	C	C	C	C	C	C	C	C
1676 mm (66")	C	C	C	C	C	C	C	C	C	C
1829 mm (72")	C	C	C	C	C	C	C	C	C	C
<b>Light Material Buckets</b>										
1829 mm (72")	C	C	C	C	C	C	C	C	C	C
1981 mm (78")	C	C	C	C	C	C	C	C	C	C
2134 mm (84")	C	C	C	C	C	C	C	C	C	C
2438 mm (96")	C	C	C	C	C	C	C	C	C	C
<b>Multi-Purpose Buckets</b>										
1524 mm (60")	C	C	C	C	C	C	C	C	C	C
1676 mm (66")	C	C	C	C	C	C	C	C	C	C
1829 mm (72")	C	C	C	C	C	C	C	C	C	C
1981 mm (78")	C	C	C	C	C	C	C	C	C	C
2134 mm (84")	C	C	C	C	C	C	C	C	C	C
<b>Industrial Grapple Buckets</b>										
1524 mm (60")	C	C	C	C	C	C	C	C	C	C
1676 mm (66")	C	C	C	C	C	C	C	C	C	C
1829 mm (72")	C	C	C	C	C	C	C	C	C	C
1981 mm (78")	C	C	C	C	C	C	C	C	C	C
<b>Industrial Grapple Forks</b>										
1676 mm (66")	C	C	C	C	C	C	C	C	C	C
1829 mm (72")	C	C	C	C	C	C	C	C	C	C
<b>Industrial Grapple Rakes</b>										
1829 mm (72")	C	C	C	C	C	C	C	C	C	C
2134 mm (84")	C	C	C	C	C	C	C	C	C	C
<b>Utility Grapple Buckets</b>										
1676 mm (66")	C	C	C	C	C	C	C	C	C	C
1829 mm (72")	C	C	C	C	C	C	C	C	C	C

C – Compatible.

**CAT WORK TOOL COMPATIBILITY**

	216B3	226B3	226D	232D	236D	242D	246D	262D	272D2	272D2 XHP
<b>Carriage</b>	C	C	C	C	C	C	C	C	C	C
<b>Pallet Forks</b>										
910 mm (36") Tines	C	C	C	C	C	C	C	C	C	C
1070 mm (42") Tines	C	C	C	C	C	C	C	C	C	C
1220 mm (48") Tines	C	C	C	C	C	C	C	C	C	C
<b>Utility Grapple Forks</b>										
1676 mm (66")	C	C	C	C	C	C	C	C	C	C
1829 mm (72")	C	C	C	C	C	C	C	C	C	C
<b>Utility Forks</b>										
1676 mm (66")	C	C	C	C	C	C	C	C	C	C
1829 mm (72")	C	C	C	C	C	C	C	C	C	C
<b>Angle Blades</b>										
1829 mm (72")	C	C	C	C	C	C	C	C	C	C
2134 mm (84")	C	C	C	C	C	C	C	C	C	C
<b>Dozer Blades</b>										
2000 mm (79")	C	C	C	C	C	C	C	C	C	C
2337 mm (92")	C	C	C	C	C	C	C	C	C	C
<b>A14B Auger</b>	C	C	C	C	C	C	C	C	C	C
<b>A19B Auger</b>	C	C	C	C	C	C	C	C	C	C
<b>A26B Auger</b>	X	C	C	C	C	C	C	C	C	C
<b>BH150 Backhoe</b>	C	C	C	C	C	C	C	C	C	C
<b>BH160 Backhoe</b>	X	X	X	X	X	X	C	C	C	C
<b>BR160 Brushcutter</b>	C	C	C	C	X	X	X	X	X	X
<b>BR166 Brushcutter</b>	C	C	X	X	C	C	C	C	C	C
<b>BR172 Brushcutter</b>	C	C	X	X	C	C	C	C	C	C
<b>BR272 Brushcutter</b>	X	C	C	C	X	X	X	X	X	X
<b>BR378 Brushcutter</b>	X	X	X	X	X	X	C	C	C	C
<b>BP115C Pickup Broom</b>	C	C*	C*	C*	C*	C	C	C	C	C
<b>BP118C Pickup Broom</b>	X	X	X	X	C*	C	C	C	C	C
<b>BA118C Angle Broom</b>	C	C	C	C	C	C	C	C	C	C
<b>BU115 Utility Broom</b>	C	C	C	C	C	C	C	C	C	C
<b>BU118 Utility Broom</b>	X	X	X	X	C*	C*	C	C	C	C
<b>PC104B Cold Planer</b>	C	C	C	C	C	C	C	C	C	C
<b>PC205B Cold Planer</b>	X	C	C	C	C	C	C	C	C	C
<b>PC305B Cold Planer</b>	X	C	C	C	C	C	C	C	C	C
<b>PC306B Cold Planer</b>	X	C	C	C	C	C	C	C	C	C
<b>PC306B XD Cold Planer</b>	X	X	X	X	X	X	X	X	C*	C*
<b>PC310B Cold Planer</b>	X	X	X	X	X	X	C*	C	C	C
<b>PC310B XD Cold Planer</b>	X	X	X	X	X	X	X	X	X	X
<b>PC408B Cold Planer</b>	X	X	X	X	X	X	X	X	X	C
<b>PC412B Cold Planer</b>	X	X	X	X	X	X	X	X	X	X

C – Compatible.  
 C\* – Compatible but Lift Restrictions Apply.  
 X – Not Compatible.

**CAT WORK TOOL COMPATIBILITY**

	216B3	226B3	226D	232D	236D	242D	246D	262D	272D2	272D2 XHP
H55E S Hammer	C,D	C,D	C,D	C,D	C,D	C,D	C,D	C,D	C,D	C,D
H65E S Hammer	C,D	C,D	C,D	C,D	C,D	C,D	C,D	C,D	C,D	C,D
LR15B Landscape Rake	C	C*	C*	C*	C*	C*	C	C	C	C
LR18B Landscape Rake	X	X	X	X	X	X	C	C	C	C
LT13B Landscape Tiller	C	C	C	C	C	C	C	C	C	C
LT18B Landscape Tiller	X	X	X	X	X	X	C	C	C	C
Material Handling Arm	C	C	C	C	C	C	C	C	C	C
HM315B Mulcher	X	X	X	X	X	X	C	C	C	C
HM415B Mulcher	X	X	X	X	X	X	X	X	X	C
PR172 Power Box Rake	C	C	C	C	C	C	C	C	C	C
PR184 Power Box Rake	C	C	C	C	C	C	C	C	C	C
PR190 Power Box Rake	C	C	C	C	C	C	C	C	C	C
S305 Shear	X	X	X	X	C,D	C,D	C,D	C,D	C,D	C,D
Sectional Snow Push 2440 mm (8 ft)	C	C	C	C	C	C	C	C	C	C
Sectional Snow Push 3050 mm (10 ft)	X	X	X	X	C	C	C	C	C	C
Sectional Snow Push 3660 mm (12 ft)	X	X	X	X	X	X	X	C	C	C
Sectional Snow Push 4270 mm (15 ft)	X	X	X	X	X	X	X	X	C	C
SR117 Snowblower	C	C	C	C	X	X	X	X	X	X
SR118 Snowblower	X	X	X	X	C	C	C	C	C	C
SR121 Snowblower	X	X	X	X	C	C	C	C	C	C
SR318 Snowblower	X	C	C	C	C	C	C	C	C	C
SR321 Snowblower	X	C	C	C	C	C	C	C	C	C
SG16B Stump Grinder	C	C	C	C	C	C	C	C	C	C
SG18B Stump Grinder	X	C	C	C	C	C	C	C	C	C
T6B Trencher	C	C	C	C	C	C	C	C	C	C
T9B Trencher	C	C	C	C	C	C	C	C	C	C
T15B Trencher	X	C*	C	C	C	C	C	C	C	C
CV16B Vibratory Compactor	C*	C*	C*	C*	C	C	C	C	C	C
CV18B Vibratory Compactor	X	X	X	X	X	X	C	C	C	C
SW345B Wheel Saw – 80 mm (3")	X	X	X	X	X	X	C^	C^	C	C
SW345B Wheel Saw – 130 mm (5")	X	X	X	X	X	X	C^	C^	C	C
SW360B Wheel Saw – 80 mm (3")	X	X	X	X	X	X	X	X	C^	C^
SW360B Wheel Saw – 100 mm (4")	X	X	X	X	X	X	X	C^	C^	C^
SW360B Wheel Saw – 130 mm (5")	X	X	X	X	X	X	X	C^	C^	C^
SW360B Wheel Saw – 150 mm (6")	X	X	X	X	X	X	X	C^	C^	C^
SW360B Wheel Saw – 200 mm (8")	X	X	X	X	X	X	X	C^	C^	C^
SW460B Wheel Saw – 80 mm (3")	X	X	X	X	X	X	X	X	X	C^
SW460B Wheel Saw – 150 mm (6")	X	X	X	X	X	X	X	X	X	C^
SW460B Wheel Saw – 200 mm (8")	X	X	X	X	X	X	X	X	X	C^
SW380B Wheel Saw – 250 mm (10")	X	X	X	X	X	X	X	X	C^	C^
SW480B Wheel Saw – 250 mm (10")	X	X	X	X	X	X	X	X	X	C^

C – Compatible.

C\* – Compatible but Lift Restrictions Apply.

C^ – Compatible but Lift Restrictions Apply and Maximum Machine Counterweights Required.

D – European Union Restrictions Apply; Refer to Operation Maintenance Manual, "Safety Section: Worktools: Demolition."

X – Not Compatible.

MODEL	257D		277D		287D	
Flywheel Power:						
Gross (SAE J1995)	55.4 kW	<b>74.3 hp</b>	55.4 kW	<b>74.3 hp</b>	55.4 kW	<b>74.3 hp</b>
Net (SAE 1349)*	54.6 kW	<b>73.2 hp</b>	54.6 kW	<b>73.2 hp</b>	54.6 kW	<b>73.2 hp</b>
Net (SAE 1349)†	54.2 kW	<b>72.7 hp</b>	54.0 kW	<b>72.4 hp</b>	54.0 kW	<b>72.4 hp</b>
Net (SAE 1349)#	53.8 kW	<b>72.1 hp</b>	53.6 kW	<b>71.8 hp</b>	53.6 kW	<b>71.8 hp</b>
Engine Model	<b>C3.3B DIT</b>		<b>C3.3B DIT</b>		<b>C3.3B DIT</b>	
Rated Engine RPM	<b>2400</b>		<b>2400</b>		<b>2400</b>	
Bore	94 mm	<b>3.7"</b>	94 mm	<b>3.7"</b>	94 mm	<b>3.7"</b>
Stroke	120 mm	<b>4.7"</b>	120 mm	<b>4.7"</b>	120 mm	<b>4.7"</b>
Displacement	3.3 L	<b>203 in<sup>3</sup></b>	3.3 L	<b>203 in<sup>3</sup></b>	3.3 L	<b>203 in<sup>3</sup></b>
No. Cylinders	<b>4</b>		<b>4</b>		<b>4</b>	
One Speed Forward	0-10.1 km/h	<b>0-6.3 mph</b>	0-8.3 km/h	<b>0-5.2 mph</b>	0-8.3 km/h	<b>0-5.2 mph</b>
Two Speed Forward	0-16.0 km/h	<b>0-9.9 mph</b>	0-12.9 km/h	<b>0-8.0 mph</b>	0-12.9 km/h	<b>0-8.0 mph</b>
One Speed Reverse	0-10.1 km/h	<b>0-6.3 mph</b>	0-8.3 km/h	<b>0-5.2 mph</b>	0-8.3 km/h	<b>0-5.2 mph</b>
Two Speed Reverse	0-16.0 km/h	<b>0-9.9 mph</b>	0-12.9 km/h	<b>0-8.0 mph</b>	0-12.9 km/h	<b>0-8.0 mph</b>
Hydraulic CycleTime, Empty Bucket:	<b>Seconds</b>		<b>Seconds</b>		<b>Seconds</b>	
Raise	<b>4.4</b>		<b>3.1</b>		<b>4.6</b>	
Dump	<b>2.4</b>		<b>2.5</b>		<b>2.3</b>	
Lower (Empty, Float Down)	<b>3.6</b>		<b>4.0</b>		<b>4.0</b>	
Total	<b>10.4</b>		<b>9.6</b>		<b>10.9</b>	
Tread Width	381 mm	<b>15"</b>	457 mm	<b>18"</b>	457 mm	<b>18"</b>
Width Over Tracks	1676 mm	<b>76"</b>	1981 mm	<b>78"</b>	1981 mm	<b>78"</b>
Ground Clearance	242 mm	<b>9.5"</b>	226 mm	<b>8.9"</b>	226 mm	<b>8.9"</b>
Fuel Tank Capacity	105 L	<b>27.7 U.S. gal</b>	94 L	<b>24.8 U.S. gal</b>	94 L	<b>24.8 U.S. gal</b>
Hydraulic Tank Capacity	39 L	<b>10.3 U.S. gal</b>	39 L	<b>10.3 U.S. gal</b>	39 L	<b>10.3 U.S. gal</b>
Hydraulic System Capacity (includes tank)	50 L	<b>13.2 U.S. gal</b>	52 L	<b>13.7 U.S. gal</b>	52 L	<b>13.7 U.S. gal</b>
Hydraulic Pump Capacity, Standard	76 L/min	<b>20 gpm</b>	86 L/min	<b>23 gpm</b>	86 L/min	<b>23 gpm</b>
Loader Hydraulic Pressure, Standard	23 000 kPa	<b>3335 psi</b>	23 000 kPa	<b>3335 psi</b>	23 000 kPa	<b>3335 psi</b>
Hydraulic Pump Capacity, XPS	112 L/min	<b>30 gpm</b>	121 L/min	<b>32 gpm</b>	121 L/min	<b>32 gpm</b>
Loader Hydraulic Pressure, XPS	23 000 kPa	<b>3335 psi</b>	28 000 kPa	<b>4061 psi</b>	28 000 kPa	<b>4061 psi</b>

\*Meets Tier 4 Final, Stage IIIB, Japan 2011 (Tier 4 Interim) emission standards.

†Meets Tier 4 Interim, Stage IIIA, Japan 2006 (Tier 3) equivalent emission standards OR Tier 2, Stage II, Japan 2001 (Tier 2) equivalent emission standards.

#Meets Tier 4 Interim, Stage IIIA, Japan 2006 (Tier 3) equivalent emission standards OR Tier 2, Stage II, Japan 2001 (Tier 2) equivalent emission standards.

<b>MODEL</b>	<b>297D2</b>		<b>297D2 XHP</b>	
Flywheel Power:				
Gross (SAE J1995)	73.2 kW	<b>98.2 hp</b>	82.0 kW	<b>110.0 hp</b>
Net (SAE 1349)*	70.6 kW	<b>94.7 hp</b>	79.0 kW	<b>105.9 hp</b>
Engine Model	<b>C3.8 DIT</b>		<b>C3.8 DITA</b>	
Rated Engine RPM	<b>2400</b>		<b>2400</b>	
Bore	100 mm	<b>3.9"</b>	100 mm	<b>3.9"</b>
Stroke	120 mm	<b>4.7"</b>	120 mm	<b>4.7"</b>
Displacement	3.8 L	<b>231.9 in<sup>3</sup></b>	3.8 L	<b>231.9 in<sup>3</sup></b>
No. Cylinders	<b>4</b>		<b>4</b>	
One Speed Forward	9.6 km/h	<b>5.9 mph</b>	9.6 km/h	<b>5.9 mph</b>
Two Speed Forward	15.1 km/h	<b>9.4 mph</b>	15.1 km/h	<b>9.4 mph</b>
One Speed Reverse	9.6 km/h	<b>5.9 mph</b>	9.6 km/h	<b>5.9 mph</b>
Two Speed Reverse	15.1 km/h	<b>9.4 mph</b>	15.1 km/h	<b>9.4 mph</b>
Hydraulic Cycle Time, Empty Bucket:	<b>Seconds</b>		<b>Seconds</b>	
Raise	<b>5.2</b>		<b>4.4</b>	
Dump	<b>2.3</b>		<b>2.0</b>	
Lower (Empty, Float Down)	<b>4.6</b>		<b>4.7</b>	
Total	<b>12.1</b>		<b>11.1</b>	
Tread Width	400 mm	<b>15.7"</b>	400 mm	<b>15.7"</b>
Width Over Tracks	1984 mm	<b>78.1"</b>	1984 mm	<b>78.1"</b>
Ground Clearance	223 mm	<b>8.8"</b>	223 mm	<b>8.8"</b>
Fuel Tank Capacity	122 L	<b>32.2 U.S. gal</b>	122 L	<b>32.2 U.S. gal</b>
Hydraulic Tank Capacity	39 L	<b>10.3 U.S. gal</b>	39 L	<b>10.3 U.S. gal</b>
Hydraulic System Capacity (includes tank)	55 L	<b>14.5 U.S. gal</b>	55 L	<b>14.5 U.S. gal</b>
Hydraulic Pump Capacity, Standard	86 L/min	<b>23 gpm</b>	86 L/min	<b>23 gpm</b>
Loader Hydraulic Pressure, Standard	23 000 kPa	<b>3336 psi</b>	23 000 kPa	<b>3336 psi</b>
Hydraulic Pump Capacity, XPS	121 L/min	<b>32 gpm</b>	—	—
Loader Hydraulic Pressure, XPS	28 000 kPa	<b>4061 psi</b>	—	—
Hydraulic Pump Capacity, XHP	—	—	150 L/min	<b>40 gpm</b>
Loader Hydraulic Pressure, XHP	—	—	28 000 kPa	<b>4061 psi</b>

\*Meets Tier 4 Final, Stage IIIB, Japan 2011 (Tier 4 Interim) emission standards.

Bucket Type		General Purpose: Bolt-on Edge		Multi-Purpose: Bolt-on Edge	
Bucket Width		1680 mm (66")	1830 mm (72")	1680 mm (66")	1830 mm (72")
Ground Engaging Type		Bolt-on Edge	Bolt-on Edge	Bolt-on Edge	Bolt-on Edge
Bucket Assembly No.		279-5369	279-5373	279-5391	279-5399
Rated bucket capacity	m <sup>3</sup>	0.40	0.44	0.34	0.37
	yd <sup>3</sup>	<b>0.52</b>	<b>0.58</b>	<b>0.44</b>	<b>0.48</b>
Struck capacity	m <sup>3</sup>	0.29	0.31	0.25	0.26
	yd <sup>3</sup>	<b>0.38</b>	<b>0.41</b>	<b>0.33</b>	<b>0.34</b>
Width	mm	1740	1893	1749	1902
	in	<b>68.5</b>	<b>74.5</b>	<b>68.9</b>	<b>74.9</b>
Dump clearance at maximum lift/dump	mm	2190	2188	2174	2172
	in	<b>86.2</b>	<b>86.2</b>	<b>85.6</b>	<b>85.5</b>
Reach at maximum lift/dump	mm	711	712	722	723
	in	<b>28.0</b>	<b>28.0</b>	<b>28.4</b>	<b>28.5</b>
Floor angle at maximum lift/dump	degrees	<b>-53.4</b>	<b>-53.4</b>	<b>-53.7</b>	<b>-53.7</b>
Floor angle at maximum lift/rack back	degrees	<b>85.9</b>	<b>85.8</b>	<b>85.6</b>	<b>85.5</b>
Clearance at maximum lift/level bucket	mm	2854	2853	2844	2843
	in	<b>112.3</b>	<b>112.3</b>	<b>112.0</b>	<b>111.9</b>
Hinge pin height at maximum lift	mm	3064	3063	3057	3056
	in	<b>120.6</b>	<b>120.6</b>	<b>120.4</b>	<b>120.3</b>
Maximum overall height	mm	3979	3978	3978	3977
	in	<b>156.7</b>	<b>156.6</b>	<b>156.6</b>	<b>156.6</b>
Reach at level lift arm/bucket	mm	1441	1442	1454	1455
	in	<b>56.7</b>	<b>56.8</b>	<b>57.2</b>	<b>57.3</b>
Maximum floor angle at minimum lift	degrees	<b>23.8</b>	<b>23.8</b>	<b>23.8</b>	<b>23.8</b>
Dig depth with level bucket	mm	-20	-21	-29	-30
	in	<b>-0.8</b>	<b>-0.8</b>	<b>-1.2</b>	<b>-1.2</b>
Overall length with bucket on ground	mm	3555	3555	3561	3560
	in	<b>140.0</b>	<b>140.0</b>	<b>140.2</b>	<b>140.2</b>
Front clearance circle radius (with bucket)	mm	2257	2288	2260	2291
	in	<b>88.9</b>	<b>90.1</b>	<b>89.0</b>	<b>90.2</b>
Tipping load	kg	2365.9	2349.0	2211.5	2189.6
	lb	<b>5216</b>	<b>5179</b>	<b>4876</b>	<b>4827</b>
Breakout force — lift	kg	1994.8	1981.6	1885.8	1867.4
	lb	<b>4398</b>	<b>4369</b>	<b>4157</b>	<b>4117</b>
Breakout force — tilt	kg	2033.4	2024.3	1972.5	1962.9
	lb	<b>4483</b>	<b>4463</b>	<b>4348</b>	<b>4327</b>
Operating weight	kg	3693.0	3708.5	3826.4	3849.2
	lb	<b>8142</b>	<b>8176</b>	<b>8436</b>	<b>8486</b>

Bucket Type		Dirt: Bolt-on Edge	
		1680 mm (66")	1830 mm (72")
Bucket Width			
Ground Engaging Type		Bolt-on Edge	Bolt-on Edge
Bucket Assembly No.		279-5441	285-6090
Rated bucket capacity	m <sup>3</sup>	0.37	0.41
	yd <sup>3</sup>	<b>0.48</b>	<b>0.54</b>
Struck capacity	m <sup>3</sup>	0.27	0.30
	yd <sup>3</sup>	<b>0.35</b>	<b>0.39</b>
Width	mm	1740	1893
	in	<b>68.5</b>	<b>74.5</b>
Dump clearance at maximum lift/dump	mm	2235	2234
	in	<b>88.0</b>	<b>88.0</b>
Reach at maximum lift/dump	mm	679	681
	in	<b>26.7</b>	<b>26.8</b>
Floor angle at maximum lift/dump	degrees	<b>-53.3</b>	<b>-53.4</b>
Floor angle at maximum lift/rack back	degrees	<b>85.9</b>	<b>85.9</b>
Clearance at maximum lift/level bucket	mm	2857	2856
	in	<b>112.5</b>	<b>112.5</b>
Hinge pin height at maximum lift	mm	3065	3064
	in	<b>120.7</b>	<b>120.6</b>
Maximum overall height	mm	3928	3927
	in	<b>154.7</b>	<b>154.6</b>
Reach at level lift arm/bucket	mm	1387	1388
	in	<b>54.6</b>	<b>54.6</b>
Maximum floor angle at minimum lift	degrees	<b>23.8</b>	<b>23.8</b>
Dig depth with level bucket	mm	-17	-17
	in	<b>-0.7</b>	<b>-0.7</b>
Overall length with bucket on ground	mm	3502	3502
	in	<b>137.9</b>	<b>137.9</b>
Front clearance circle radius (with bucket)	mm	2211	2242
	in	<b>87.0</b>	<b>88.3</b>
Tipping load	kg	2449.3	2433.4
	lb	<b>5400</b>	<b>5365</b>
Breakout force — lift	kg	2048.5	2034.6
	lb	<b>4516</b>	<b>4485</b>
Breakout force — tilt	kg	2182.4	2172.7
	lb	<b>4811</b>	<b>4790</b>
Operating weight	kg	3670.3	3686.4
	lb	<b>8092</b>	<b>8127</b>

Work Tool	Pallet Fork			
		910 mm (36")	1070 mm (42")	1220 mm (48")
<b>Tine Length</b>		<b>910 mm (36")</b>	<b>1070 mm (42")</b>	<b>1220 mm (48")</b>
<b>Carriage Assembly No.</b>		<b>353-1694</b>	<b>353-1696</b>	<b>353-1697</b>
Carriage overall width without step	mm	1160	1160	1160
	in	<b>45.7</b>	<b>45.7</b>	<b>45.7</b>
Carriage step additional width	mm	106	106	106
	in	<b>4.2</b>	<b>4.2</b>	<b>4.2</b>
Carriage height above blade top	mm	926	926	926
	in	<b>36.5</b>	<b>36.5</b>	<b>36.5</b>
Blade surface height at maximum height	mm	2959	2958	2957
	in	<b>116.5</b>	<b>116.5</b>	<b>116.4</b>
Shank front face reach at maximum height	mm	622	624	626
	in	<b>24.5</b>	<b>24.6</b>	<b>24.7</b>
Blade surface height at level lift arms	mm	1405	1405	1403
	in	<b>55.3</b>	<b>55.3</b>	<b>55.2</b>
Shank front face reach at level lift arms	mm	818	819	820
	in	<b>32.2</b>	<b>32.2</b>	<b>32.3</b>
Blade surface height at minimum lift	mm	81	81	80
	in	<b>3.2</b>	<b>3.2</b>	<b>3.1</b>
Shank front face reach at minimum lift	mm	483	483	484
	in	<b>19.0</b>	<b>19.0</b>	<b>19.1</b>
Overall length at minimum lift, level tine	mm	3855	4015	4165
	in	<b>151.8</b>	<b>158.1</b>	<b>164.0</b>
Tipping load	kg	1950.7	1846.9	1757.5
	lb	<b>4300</b>	<b>4072</b>	<b>3875</b>
Operating weight	kg	3614.4	3624.7	3634.3
	lb	<b>7968</b>	<b>7991</b>	<b>8012</b>



Bucket Type		General Purpose: Bolt-on Edge	
		1981 mm (78")	2134 mm (84")
Bucket Width		1981 mm (78")	2134 mm (84")
Tire Size		12 x 16.5	12 x 16.5
Ground Engaging Type		Bolt-on Edge	Bolt-on Edge
Bucket Assembly No.		279-5377	296-8192
Rated bucket capacity	m <sup>3</sup>	0.48	0.63
	yd <sup>3</sup>	0.63	0.82
Struck capacity	m <sup>3</sup>	0.32	0.59
	yd <sup>3</sup>	0.42	0.77
Width	mm	2045	2198
	in	80.5	86.5
Dump clearance at maximum lift/dump	mm	2418	2355
	in	95.2	92.7
Reach at maximum lift/dump	mm	655	730
	in	25.8	28.7
Floor angle at maximum lift/dump	degrees	-38.9	-39.0
Floor angle at maximum lift/rack back	degrees	96.1	96.0
Clearance at maximum lift/level bucket	mm	2963	2960
	in	116.7	116.5
Hinge pin height at maximum lift	mm	3173	3171
	in	124.9	124.9
Maximum overall height	mm	4134	4224
	in	162.7	166.3
Reach at level lift arm/bucket	mm	1480	1575
	in	58.3	62.0
Maximum floor angle at minimum lift	degrees	24.2	24.2
Dig depth with level bucket	mm	-8	-12
	in	-0.3	-0.5
Overall length with bucket on ground	mm	3777	3870
	in	148.7	152.4
Front clearance circle radius (with bucket)	mm	2412	2525
	in	94.9	99.4
Tipping load	kg	2418.7	2325.6
	lb	5332	5127
Breakout force — lift	kg	2630.1	2515.2
	lb	5798	5545
Breakout force — tilt	kg	2826.4	2515.5
	lb	6231	5546
Operating weight	kg	4267.3	4304.2
	lb	9408	9489

Bucket Type		Multi-Purpose: Bolt-on Edge		Dirt: Bolt-on Edge
		1981 mm (78")	2134 mm (84")	1981 mm (78")
Bucket Width		1981 mm (78")	2134 mm (84")	1981 mm (78")
Tire Size		12 x 16.5	12 x 16.5	12 x 16.5
Bucket Assembly No.		Bolt-on Edge	Bolt-on Edge	Bolt-on Edge
Bucket Assembly No.		279-5402	296-8057	268-4083
Rated bucket capacity	m <sup>3</sup>	0.40	0.43	0.44
	yd <sup>3</sup>	0.52	0.56	0.58
Struck capacity	m <sup>3</sup>	0.28	0.30	0.32
	yd <sup>3</sup>	0.37	0.39	0.42
Width	mm	2045	2207	2045
	in	80.5	86.9	80.5
Dump clearance at maximum lift/dump	mm	2402	2400	2454
	in	94.6	94.5	96.6
Reach at maximum lift/dump	mm	670	671	614
	in	26.4	26.4	24.2
Floor angle at maximum lift/dump	degrees	-39.2	-39.2	-38.8
Floor angle at maximum lift/rack back	degrees	95.8	95.7	96.1
Clearance at maximum lift/level bucket	mm	2954	2953	2967
	in	116.3	116.3	116.8
Hinge pin height at maximum lift	mm	3167	3166	3174
	in	124.7	124.7	125.0
Maximum overall height	mm	4134	4133	4082
	in	162.8	162.7	160.7
Reach at level lift arm/bucket	mm	1494	1495	1426
	in	58.8	58.9	56.1
Maximum floor angle at minimum lift	degrees	24.2	24.2	24.2
Dig depth with level bucket	mm	-17	-18	-5
	in	-0.7	-0.7	-0.2
Overall length with bucket on ground	mm	3783	3782	3724
	in	148.9	148.9	146.6
Front clearance circle radius (with bucket)	mm	2414	2448	2366
	in	95.1	96.4	93.1
Tipping load	kg	2263.9	2241.3	2504.9
	lb	4991	4941	5522
Breakout force — lift	kg	2511.3	2491.6	2694.8
	lb	5537	5493	5941
Breakout force — tilt	kg	2757.1	2744.9	3026.1
	lb	6078	6051	6671
Operating weight	kg	4413.6	4437.6	4248.2
	lb	9730	9783	9366

Work Tool		Pallet Fork		
Tine Length		910 mm (36")	1070 mm (42")	1220 mm (48")
Tire Size		10 x 16.5	10 x 16.5	10 x 16.5
Carriage Assembly No.		353-1694	353-1696	353-1697
Carriage overall width without step	mm	1160	1160	1160
	in	<b>45.7</b>	<b>45.7</b>	<b>45.7</b>
Carriage step additional width	mm	106	106	106
	in	<b>4.2</b>	<b>4.2</b>	<b>4.2</b>
Carriage height above blade top	mm	926	926	926
	in	<b>36.5</b>	<b>36.5</b>	<b>36.5</b>
Blade surface height at maximum height	mm	3024	3024	3022
	in	<b>119.1</b>	<b>119.0</b>	<b>119.0</b>
Shank front face reach at maximum height	mm	457	459	461
	in	<b>18.0</b>	<b>18.1</b>	<b>18.2</b>
Blade surface height at level lift arms	mm	1449	1448	1446
	in	<b>57.1</b>	<b>57.0</b>	<b>56.9</b>
Shank front face reach at level lift arms	mm	902	903	905
	in	<b>35.5</b>	<b>35.6</b>	<b>35.6</b>
Blade surface height at minimum lift	mm	46	45	43
	in	<b>1.8</b>	<b>1.8</b>	<b>1.7</b>
Shank front face reach at minimum lift	mm	394	394	394
	in	<b>15.5</b>	<b>15.5</b>	<b>15.5</b>
Overall length at minimum lift, level tine	mm	4056	4216	4366
	in	<b>159.7</b>	<b>166.0</b>	<b>171.9</b>
Tipping load	kg	2098.2	1998.8	1912.4
	lb	<b>4626</b>	<b>4407</b>	<b>4216</b>
Operating weight	kg	4158.9	4169.2	4178.8
	lb	<b>9169</b>	<b>9191</b>	<b>9213</b>

Bucket Type		General Purpose: Bolt-on Edge	
		1981 mm (78")	2134 mm (84")
Bucket Width		1981 mm (78")	2134 mm (84")
Tire Size		12 x 16.5	12 x 16.5
Ground Engaging Type		Bolt-on Edge	Bolt-on Edge
Bucket Assembly No.		279-5377	296-8192
Rated bucket capacity	m <sup>3</sup>	0.48	0.63
	yd <sup>3</sup>	0.63	0.82
Struck capacity	m <sup>3</sup>	0.32	0.59
	yd <sup>3</sup>	0.42	0.77
Width	mm	2045	2198
	in	80.5	86.5
Dump clearance at maximum lift/dump	mm	2304	2227
	in	90.7	87.7
Reach at maximum lift/dump	mm	822	882
	in	32.3	34.7
Floor angle at maximum lift/dump	degrees	-51.3	-51.4
Floor angle at maximum lift/rack back	degrees	83.6	83.5
Clearance at maximum lift/level bucket	mm	2962	2958
	in	116.6	116.5
Hinge pin height at maximum lift	mm	3172	3169
	in	124.9	124.8
Maximum overall height	mm	4086	4175
	in	160.9	164.4
Reach at level lift arm/bucket	mm	1373	1468
	in	54.0	57.8
Maximum floor angle at minimum lift	degrees	26.3	26.3
Dig depth with level bucket	mm	-25	-29
	in	-1.0	-1.1
Overall length with bucket on ground	mm	3779	3872
	in	148.8	152.4
Front clearance circle radius (with bucket)	mm	2412	2526
	in	95.0	99.4
Tipping load	kg	3470.3	3356.3
	lb	7651	7399
Breakout force — lift	kg	2375.6	2275.8
	lb	5237	5017
Breakout force — tilt	kg	2922.6	2602.2
	lb	6443	5737
Operating weight	kg	4545.7	4582.6
	lb	10,021	10,103

Bucket Type		Multi-Purpose: Bolt-on Edge		Dirt: Bolt-on Edge
Bucket Width		1981 mm (78")	2134 mm (84")	1981 mm (78")
Tire Size		12 x 16.5	12 x 16.5	12 x 16.5
Bucket Assembly No.		Bolt-on Edge	Bolt-on Edge	Bolt-on Edge
Bucket Assembly No.		279-5402	296-8057	268-4083
Rated bucket capacity	m <sup>3</sup>	0.40	0.43	0.44
	yd <sup>3</sup>	<b>0.52</b>	<b>0.56</b>	<b>0.58</b>
Struck capacity	m <sup>3</sup>	0.28	0.30	0.32
	yd <sup>3</sup>	<b>0.37</b>	<b>0.39</b>	<b>0.42</b>
Width	mm	2045	2207	2045
	in	<b>80.5</b>	<b>86.9</b>	<b>80.5</b>
Dump clearance at maximum lift/dump	mm	2287	2286	2348
	in	<b>90.1</b>	<b>90.0</b>	<b>92.4</b>
Reach at maximum lift/dump	mm	833	835	789
	in	<b>32.8</b>	<b>32.9</b>	<b>31.1</b>
Floor angle at maximum lift/dump	degrees	-51.6	-51.6	-51.3
Floor angle at maximum lift/rack back	degrees	<b>83.3</b>	<b>83.3</b>	<b>83.6</b>
Clearance at maximum lift/level bucket	mm	2952	2950	2965
	in	<b>116.2</b>	<b>116.2</b>	<b>116.7</b>
Hinge pin height at maximum lift	mm	3165	3163	3173
	in	<b>124.6</b>	<b>124.5</b>	<b>124.9</b>
Maximum overall height	mm	4084	4083	4035
	in	<b>160.8</b>	<b>160.7</b>	<b>158.8</b>
Reach at level lift arm/bucket	mm	1387	1388	1319
	in	<b>54.6</b>	<b>54.6</b>	<b>51.9</b>
Maximum floor angle at minimum lift	degrees	<b>26.3</b>	<b>26.3</b>	<b>26.3</b>
Dig depth with level bucket	mm	-34	-35	-22
	in	<b>-1.3</b>	<b>-1.4</b>	<b>-0.9</b>
Overall length with bucket on ground	mm	3784	3784	3726
	in	<b>149.0</b>	<b>149.0</b>	<b>146.7</b>
Front clearance circle radius (with bucket)	mm	2415	2448	2367
	in	<b>95.1</b>	<b>96.4</b>	<b>93.2</b>
Tipping load	kg	3305.2	3282.7	3679.0
	lb	<b>7287</b>	<b>7237</b>	<b>8111</b>
Breakout force — lift	kg	2254.7	2234.7	2431.2
	lb	<b>4971</b>	<b>4927</b>	<b>5360</b>
Breakout force — tilt	kg	2853.3	2841.1	3128.6
	lb	<b>6290</b>	<b>6263</b>	<b>6897</b>
Operating weight	kg	4692.0	4716.0	4526.6
	lb	<b>10,344</b>	<b>10,397</b>	<b>9979</b>

Work Tool	Pallet Fork		
	910 mm (36")	1070 mm (42")	1220 mm (48")
Tine Length	910 mm (36")	1070 mm (42")	1220 mm (48")
Tire Size	10 x 16.5	10 x 16.5	10 x 16.5
Carriage Assembly No.	353-1694	353-1696	353-1697
Carriage overall width without step	mm	1160	1160
	in	45.7	45.7
Carriage step additional width	mm	106	106
	in	4.2	4.2
Carriage height above blade top	mm	926	926
	in	36.5	36.5
Blade surface height at maximum height	mm	3011	3011
	in	118.6	118.5
Shank front face reach at maximum height	mm	811	812
	in	31.9	32.0
Blade surface height at level lift arms	mm	1484	1483
	in	58.4	58.4
Shank front face reach at level lift arms	mm	795	796
	in	31.3	31.3
Blade surface height at minimum lift	mm	38	37
	in	1.5	1.5
Shank front face reach at minimum lift	mm	401	401
	in	15.8	15.8
Overall length at minimum lift, level tine	mm	4070	4230
	in	160.2	166.5
Tipping load	kg	2854.2	2707.9
	lb	6292	5970
Operating weight	kg	4437.3	4447.6
	lb	9783	9805
			9826

Bucket Type		General Purpose: Bolt-on Edge	
		1981 mm (78")	2134 mm (84")
Bucket Width		1981 mm (78")	2134 mm (84")
Tire Size		12 x 16.5	12 x 16.5
Ground Engaging Type		Bolt-on Edge	Bolt-on Edge
Bucket Assembly No.		279-5377	296-8192
Rated bucket capacity	m <sup>3</sup>	0.48	0.63
	yd <sup>3</sup>	0.63	0.82
Struck capacity	m <sup>3</sup>	0.32	0.59
	yd <sup>3</sup>	0.42	0.77
Width	mm	2045	2198
	in	80.5	86.5
Dump clearance at maximum lift/dump	mm	2366	2289
	in	93.1	90.1
Reach at maximum lift/dump	mm	816	876
	in	32.1	34.5
Floor angle at maximum lift/dump	degrees	-51.7	-51.8
Floor angle at maximum lift/rack back	degrees	83.3	83.3
Clearance at maximum lift/level bucket	mm	3008	3000
	in	118.4	118.1
Hinge pin height at maximum lift	mm	3238	3236
	in	127.5	127.4
Maximum overall height	mm	4150	4240
	in	163.4	166.9
Reach at level lift arm/bucket	mm	1359	1454
	in	53.5	57.2
Maximum floor angle at minimum lift	degrees	27.0	26.9
Dig depth with level bucket	mm	-54	-60
	in	-2.1	-2.4
Overall length with bucket on ground	mm	4015	4107
	in	158.1	161.7
Front clearance circle radius (with bucket)	mm	2408	2516
	in	94.8	99.1
Tipping load	kg	4021.1	3893.7
	lb	8865	8584
Breakout force — lift	kg	2630.0	2526.7
	lb	5798	5570
Breakout force — tilt	kg	2988.5	2661.5
	lb	6588	5868
Operating weight	kg	4908.9	4945.8
	lb	10,822	10,903

Bucket Type	Multi-Purpose: Bolt-on Edge		Dirt: Bolt-on Edge
	1981 mm (78")	2134 mm (84")	1981 mm (78")
Bucket Width	1981 mm (78")	2134 mm (84")	1981 mm (78")
Tire Size	12 x 16.5	12 x 16.5	12 x 16.5
Bucket Assembly No.	Bolt-on Edge	Bolt-on Edge	Bolt-on Edge
Bucket Assembly No.	279-5402	296-8057	268-4083
Rated bucket capacity	m <sup>3</sup>	0.40	0.43
	yd <sup>3</sup>	0.52	0.56
Struck capacity	m <sup>3</sup>	0.28	0.30
	yd <sup>3</sup>	0.37	0.39
Width	mm	2045	2207
	in	80.5	86.9
Dump clearance at maximum lift/dump	mm	2349	2347
	in	92.5	92.4
Reach at maximum lift/dump	mm	829	831
	in	32.6	32.7
Floor angle at maximum lift/dump	degrees	-52.0	-52.0
Floor angle at maximum lift/rack back	degrees	83.1	83.0
Clearance at maximum lift/level bucket	mm	2992	2990
	in	117.8	117.7
Hinge pin height at maximum lift	mm	3231	3230
	in	127.2	127.2
Maximum overall height	mm	4149	4147
	in	163.3	163.3
Reach at level lift arm/bucket	mm	1372	1373
	in	54.0	54.0
Maximum floor angle at minimum lift	degrees	26.8	26.7
Dig depth with level bucket	mm	-66	-68
	in	-2.6	-2.7
Overall length with bucket on ground	mm	4019	4019
	in	158.2	158.2
Front clearance circle radius (with bucket)	mm	2415	2448
	in	95.1	96.4
Tipping load	kg	3848.9	3826.4
	lb	8485	8436
Breakout force — lift	kg	2508.2	2488.0
	lb	5530	5485
Breakout force — tilt	kg	2919.2	2907.0
	lb	6436	6409
Operating weight	kg	5055.2	5079.2
	lb	11,145	11,198



Work Tool		Pallet Fork		
Tine Length		910 mm (36")	1070 mm (42")	1220 mm (48")
Tire Size		10 x 16.5	10 x 16.5	10 x 16.5
Carriage Assembly No.		353-1694	353-1696	353-1697
Carriage overall width without step	mm	1160	1160	1160
	in	<b>45.7</b>	<b>45.7</b>	<b>45.7</b>
Carriage step additional width	mm	106	106	106
	in	<b>4.2</b>	<b>4.2</b>	<b>4.2</b>
Carriage height above blade top	mm	926	926	926
	in	<b>36.5</b>	<b>36.5</b>	<b>36.5</b>
Blade surface height at maximum height	mm	3116	3113	3108
	in	<b>122.7</b>	<b>122.5</b>	<b>122.4</b>
Shank front face reach at maximum height	mm	706	708	710
	in	<b>27.8</b>	<b>27.9</b>	<b>28.0</b>
Blade surface height at level lift arms	mm	1432	1429	1425
	in	<b>56.4</b>	<b>56.3</b>	<b>56.1</b>
Shank front face reach at level lift arms	mm	734	734	736
	in	<b>28.9</b>	<b>28.9</b>	<b>29.0</b>
Blade surface height at minimum lift	mm	52	49	46
	in	<b>2.1</b>	<b>1.9</b>	<b>1.8</b>
Shank front face reach at minimum lift	mm	406	406	407
	in	<b>16.0</b>	<b>16.0</b>	<b>16.0</b>
Overall length at minimum lift, level tine	mm	4308	4467	4618
	in	<b>169.6</b>	<b>175.9</b>	<b>181.8</b>
Tipping load	kg	3315.5	3146.5	3001.5
	lb	<b>7309</b>	<b>6937</b>	<b>6617</b>
Operating weight	kg	4800.5	4810.8	4820.4
	lb	<b>10,583</b>	<b>10,606</b>	<b>10,627</b>

Bucket Type		General Purpose: Bolt-on Edge	
		1981 mm (78")	2134 mm (84")
Bucket Width		1981 mm (78")	2134 mm (84")
Tire Size		12 x 16.5	12 x 16.5
Ground Engaging Type		Bolt-on Edge	Bolt-on Edge
Bucket Assembly No.		279-5377	296-8192
Rated bucket capacity	m <sup>3</sup>	0.48	0.63
	yd <sup>3</sup>	0.63	0.82
Struck capacity	m <sup>3</sup>	0.32	0.59
	yd <sup>3</sup>	0.42	0.77
Width	mm	2045	2198
	in	80.5	86.5
Dump clearance at maximum lift/dump	mm	2366	2289
	in	93.1	90.1
Reach at maximum lift/dump	mm	816	876
	in	32.1	34.5
Floor angle at maximum lift/dump	degrees	-51.7	-51.8
Floor angle at maximum lift/rack back	degrees	83.3	83.3
Clearance at maximum lift/level bucket	mm	3008	3001
	in	118.4	118.1
Hinge pin height at maximum lift	mm	3238	3236
	in	127.5	127.4
Maximum overall height	mm	4150	4240
	in	163.4	166.9
Reach at level lift arm/bucket	mm	1358	1454
	in	53.5	57.2
Maximum floor angle at minimum lift	degrees	27.0	26.9
Dig depth with level bucket	mm	-53	-60
	in	-2.1	-2.4
Overall length with bucket on ground	mm	4015	4107
	in	158.1	161.7
Front clearance circle radius (with bucket)	mm	2408	2516
	in	94.8	99.1
Tipping load	kg	4103.7	3974.6
	lb	9047	8762
Breakout force — lift	kg	2624.9	2521.7
	lb	5787	5559
Breakout force — tilt	kg	2988.5	2661.5
	lb	6588	5868
Operating weight	kg	5011.2	5048.1
	lb	11,048	11,129

Bucket Type		Multi-Purpose: Bolt-on Edge		Dirt: Bolt-on Edge
Bucket Width		1981 mm (78")	2134 mm (84")	1981 mm (78")
Tire Size		12 x 16.5	12 x 16.5	12 x 16.5
Bucket Assembly No.		Bolt-on Edge	Bolt-on Edge	Bolt-on Edge
Bucket Assembly No.		279-5402	296-8057	268-4083
Rated bucket capacity	m <sup>3</sup>	0.40	0.43	0.44
	yd <sup>3</sup>	0.52	0.56	0.58
Struck capacity	m <sup>3</sup>	0.28	0.30	0.32
	yd <sup>3</sup>	0.37	0.39	0.42
Width	mm	2045	2207	2045
	in	80.5	86.9	80.5
Dump clearance at maximum lift/dump	mm	2349	2348	2410
	in	92.5	92.4	94.9
Reach at maximum lift/dump	mm	829	830	784
	in	32.6	32.7	30.9
Floor angle at maximum lift/dump	degrees	-51.9	-52.0	-51.6
Floor angle at maximum lift/rack back	degrees	83.1	83.0	83.4
Clearance at maximum lift/level bucket	mm	2992	2990	3013
	in	117.8	117.7	118.6
Hinge pin height at maximum lift	mm	3231	3230	3239
	in	127.2	127.2	127.5
Maximum overall height	mm	4149	4147	4099
	in	163.3	163.3	161.4
Reach at level lift arm/bucket	mm	1371	1372	1305
	in	54.0	54.0	51.4
Maximum floor angle at minimum lift	degrees	26.8	26.7	27.1
Dig depth with level bucket	mm	-66	-68	-49
	in	-2.6	-2.7	-1.9
Overall length with bucket on ground	mm	4019	4019	3962
	in	158.2	158.2	156.0
Front clearance circle radius (with bucket)	mm	2415	2448	2364
	in	95.1	96.4	93.1
Tipping load	kg	3930.7	3908.2	4235.0
	lb	8666	8616	9336
Breakout force — lift	kg	2503.1	2482.9	2682.4
	lb	5518	5474	5914
Breakout force — tilt	kg	2919.2	2907.0	3199.0
	lb	6436	6409	7052
Operating weight	kg	5157.5	5181.5	4992.1
	lb	11,370	11,423	11,006

Work Tool	Pallet Fork		
Tine Length	910 mm (36")	1070 mm (42")	1220 mm (48")
Tire Size	10 x 16.5	10 x 16.5	10 x 16.5
Carriage Assembly No.	353-1694	353-1696	353-1697
Carriage overall width without step	mm 1160	1160	1160
	in 45.7	45.7	45.7
Carriage step additional width	mm 106	106	106
	in 4.2	4.2	4.2
Carriage height above blade top	mm 926	926	926
	in 36.5	36.5	36.5
Blade surface height at maximum height	mm 3116	3112	3108
	in 122.7	122.5	122.4
Shank front face reach at maximum height	mm 707	708	710
	in 27.8	27.9	28.0
Blade surface height at level lift arms	mm 1432	1429	1425
	in 56.4	56.3	56.1
Shank front face reach at level lift arms	mm 734	734	736
	in 28.9	28.9	29.0
Blade surface height at minimum lift	mm 52	49	45
	in 2.0	1.9	1.8
Shank front face reach at minimum lift	mm 406	406	407
	in 16.0	16.0	16.0
Overall length at minimum lift, level tine	mm 4308	4467	4618
	in 169.6	175.9	181.8
Tipping load	kg 3381.9	3209.8	3062.0
	lb 7456	7076	6751
Operating weight	kg 4902.8	4913.1	4922.7
	lb 10,809	10,831	10,853

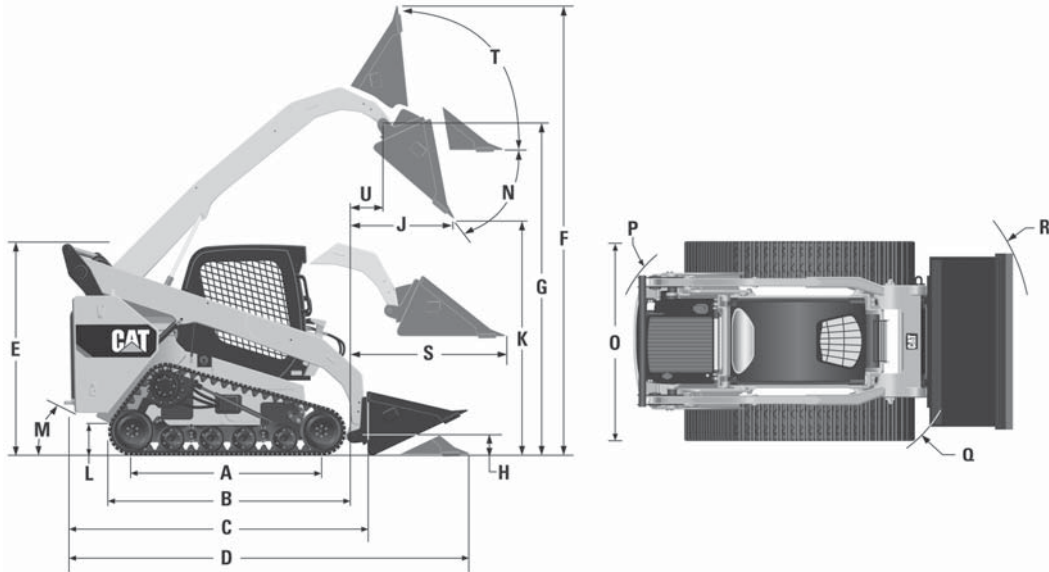

MODEL	257D		277D		287D	
Operating weight	3651 kg	<b>8048 lb</b>	4215 kg	<b>9293 lb</b>	4504 kg	<b>9929 lb</b>
Rated operating capacity at 35%	889 kg	<b>1960 lb</b>	1045 kg	<b>2303 lb</b>	1270 kg	<b>2800 lb</b>
Rated operating capacity at 50%	1270 kg	<b>2800 lb</b>	1492 kg	<b>3290 lb</b>	1814 kg	<b>4000 lb</b>
Tipping load	2540 kg	<b>5600 lb</b>	2985 kg	<b>6580 lb</b>	3629 kg	<b>8000 lb</b>
Breakout force, tilt cylinder	2284 kg	<b>5035 lb</b>	3304 kg	<b>7285 lb</b>	3307 kg	<b>7291 lb</b>
Ground pressure	31.3 kPa	<b>4.5 psi</b>	25.0 kPa	<b>3.6 psi</b>	26.7 kPa	<b>3.9 psi</b>
A Length of track on ground	1499 mm	<b>59.0"</b>	1807 mm	<b>71.1"</b>	1807 mm	<b>71.1"</b>
B Overall length of track	1898 mm	<b>74.7"</b>	2285 mm	<b>90.0"</b>	2285 mm	<b>90.0"</b>
C Length without bucket	2767 mm	<b>108.9"</b>	2995 mm	<b>117.9"</b>	2995 mm	<b>117.9"</b>
D Length with bucket on ground	3486 mm	<b>137.3"</b>	3714 mm	<b>146.2"</b>	3714 mm	<b>146.2"</b>
E Height to top of cab	2129 mm	<b>83.8"</b>	2113 mm	<b>83.2"</b>	2113 mm	<b>83.2"</b>
F Maximum overall height	3932 mm	<b>154.8"</b>	4052 mm	<b>159.5"</b>	4015 mm	<b>158.1"</b>
G Bucket pin height at maximum lift	3091 mm	<b>121.7"</b>	3174 mm	<b>125.0"</b>	3178 mm	<b>125.1"</b>
H Bucket pin height at carry position	215 mm	<b>8.5"</b>	202 mm	<b>8.0"</b>	190 mm	<b>7.5"</b>
J Reach at maximum lift and dump	637 mm	<b>25.1"</b>	598 mm	<b>23.5"</b>	783 mm	<b>30.8"</b>
K Clearance at maximum lift and dump	2300 mm	<b>90.5"</b>	2488 mm	<b>97.9"</b>	2387 mm	<b>94.0"</b>
L Ground clearance	242 mm	<b>9.5"</b>	226 mm	<b>8.9"</b>	226 mm	<b>8.9"</b>
M Departure angle		<b>35°</b>		<b>38°</b>		<b>38°</b>
N Maximum dump angle		<b>52°</b>		<b>39°</b>		<b>51°</b>
O Vehicle width	1676 mm	<b>66.0"</b>	1981 mm	<b>78.0"</b>	1981 mm	<b>78.0"</b>
P Turning radius from center — machine rear	1555 mm	<b>61.2"</b>	1713 mm	<b>67.4"</b>	1713 mm	<b>67.4"</b>
Q Turning radius from center — coupler	1399 mm	<b>55.1"</b>	1493 mm	<b>58.8"</b>	1493 mm	<b>58.8"</b>
R Turning radius from center — bucket	2191 mm	<b>86.3"</b>	2336 mm	<b>92.0"</b>	2336 mm	<b>92.0"</b>
S Maximum reach with arms parallel to ground	1334 mm	<b>52.5"</b>	1395 mm	<b>54.9"</b>	1292 mm	<b>50.9"</b>
T Rack back angle at maximum height		<b>87°</b>		<b>94°</b>		<b>84°</b>
U Bucket pin reach at maximum lift	367 mm	<b>14.5"</b>	—		391 mm	<b>15.4"</b>

NOTE: Based on 75 kg (165 lb) operator, all fluids, two speed, OROPS, 1981 mm (78") dirt bucket, standard flow hydraulics, mechanical suspension seat, no optional counterweights and manual quick coupler (unless otherwise noted). 257D based on 1676 mm (66") dirt bucket and one speed.

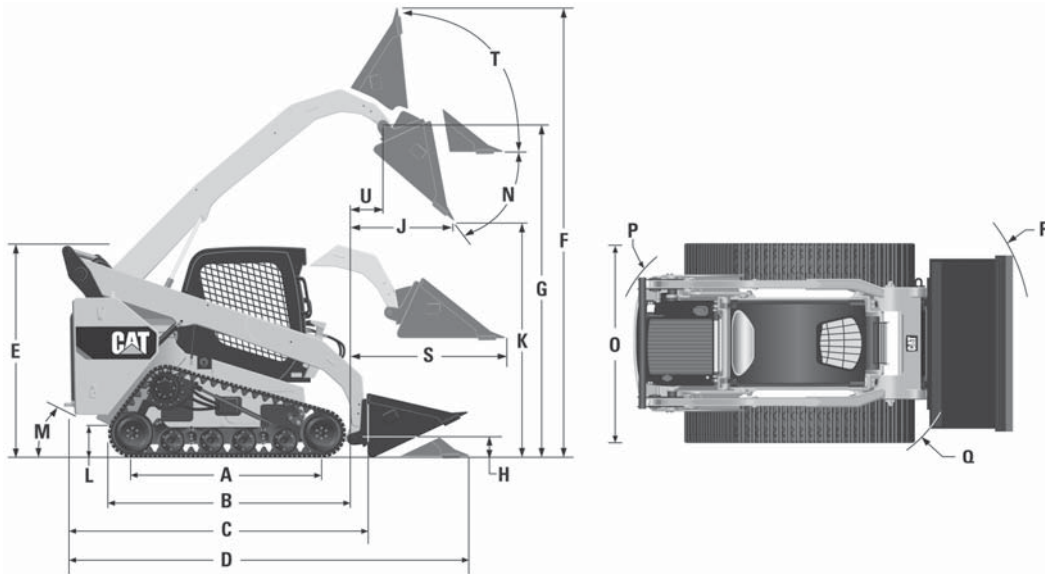

MODEL	297D2		297D2 XHP	
Operating weight	4850 kg	<b>10,692 lb</b>	4952 kg	<b>10,918 lb</b>
Rated operating capacity at 35%	1492 kg	<b>3290 lb</b>	1524 kg	<b>3360 lb</b>
Rated operating capacity at 50%	2332 kg	<b>4700 lb</b>	2177 kg	<b>4800 lb</b>
Tipping load	4264 kg	<b>9400 lb</b>	4354 kg	<b>9600 lb</b>
Breakout force, tilt cylinder	3387 kg	<b>7468 lb</b>	3387 kg	<b>7468 lb</b>
Ground pressure	28.8 kPa	<b>4.2 psi</b>	29.4 kPa	<b>4.3 psi</b>
A Length of track on ground	1807 mm	<b>71.1"</b>	1807 mm	<b>71.1"</b>
B Overall length of track	2286 mm	<b>90.0"</b>	2286 mm	<b>90.0"</b>
C Length without bucket	3201 mm	<b>126.0"</b>	3201 mm	<b>126.0"</b>
D Length with bucket on ground	3942 mm	<b>155.2"</b>	3942 mm	<b>155.2"</b>
E Height to top of cab	2114 mm	<b>83.2"</b>	2114 mm	<b>83.2"</b>
F Maximum overall height	4076 mm	<b>160.5"</b>	4076 mm	<b>160.5"</b>
G Bucket pin height at maximum lift	3241 mm	<b>127.6"</b>	3241 mm	<b>127.6"</b>
H Bucket pin height at carry position	200 mm	<b>7.9"</b>	200 mm	<b>7.9"</b>
J Reach at maximum lift and dump	776 mm	<b>30.5"</b>	776 mm	<b>30.5"</b>
K Clearance at maximum lift and dump	2445 mm	<b>96.3"</b>	2445 mm	<b>96.3"</b>
L Ground clearance	223 mm	<b>8.8"</b>	223 mm	<b>8.8"</b>
M Departure angle		<b>30°</b>		<b>30°</b>
N Maximum dump angle		<b>52°</b>		<b>52°</b>
O Vehicle width	1984 mm	<b>78.1"</b>	1984 mm	<b>78.1"</b>
P Turning radius from center — machine rear	1864 mm	<b>73.4"</b>	1864 mm	<b>73.4"</b>
Q Turning radius from center — coupler	1504 mm	<b>59.2"</b>	1504 mm	<b>59.2"</b>
R Turning radius from center — bucket	2333 mm	<b>91.8"</b>	2333 mm	<b>91.8"</b>
S Maximum reach with arms parallel to ground	1260 mm	<b>49.6"</b>	1260 mm	<b>49.6"</b>
T Rack back angle at maximum height		<b>83°</b>		<b>83°</b>
U Bucket pin reach at maximum lift	387 mm	<b>15.2"</b>	387 mm	<b>15.2"</b>

**NOTE:** 297D2 based on 75 kg (165 lb) operator, all fluids, two speed, C2 enclosed cab with heat, glass door, 1981 mm (78") dirt bucket, standard flow hydraulics, mechanical suspension seat, no optional counterweights and manual quick coupler (unless otherwise noted).

**NOTE:** 297D2 XHP based on 75 kg (165 lb) operator, all fluids, two speed, C3 enclosed cab with A/C, glass door, 1981 mm (78") dirt bucket, high flow hydraulics, air suspension seat, no optional counterweights and manual quick coupler (unless otherwise noted).

**CAT WORK TOOL COMPATIBILITY**

	<b>257D</b>	<b>277D</b>	<b>287D</b>	<b>297D2</b>	<b>297D2 XHP</b>
<b>General Purpose Buckets</b>					
1524 mm (60")	C	C	C	C	C
1676 mm (66")	C	C	C	C	C
1829 mm (72")	C	C	C	C	C
1981 mm (78")	C	C	C	C	C
<b>High Capacity Bucket (GP)</b>					
2134 mm (84")	C	C	C	C	C
<b>Dirt Buckets</b>					
1372 mm (54")	C	C	C	C	C
1524 mm (60")	C	C	C	C	C
1676 mm (66")	C	C	C	C	C
1829 mm (72")	C	C	C	C	C
1981 mm (78")	C	C	C	C	C
<b>Utility Buckets</b>					
1524 mm (60")	C	C	C	C	C
1676 mm (66")	C	C	C	C	C
1829 mm (72")	C	C	C	C	C
<b>Light Material Buckets</b>					
1829 mm (72")	C	C	C	C	C
1981 mm (78")	C	C	C	C	C
2134 mm (84")	C	C	C	C	C
2438 mm (96")	C	C	C	C	C
<b>Multi-Purpose Buckets</b>					
1524 mm (60")	C	C	C	C	C
1676 mm (66")	C	C	C	C	C
1829 mm (72")	C	C	C	C	C
1981 mm (78")	C	C	C	C	C
2134 mm (84")	C	C	C	C	C
<b>Industrial Grapple Buckets</b>					
1524 mm (60")	C	C	C	C	C
1676 mm (66")	C	C	C	C	C
1829 mm (72")	C	C	C	C	C
1981 mm (78")	C	C	C	C	C
<b>Industrial Grapple Forks</b>					
1676 mm (66")	C	C	C	C	C
1829 mm (72")	C	C	C	C	C
<b>Industrial Grapple Rakes</b>					
1829 mm (72")	C	C	C	C	C
2134 mm (84")	C	C	C	C	C
<b>Utility Grapple Buckets</b>					
1676 mm (66")	C	C	C	C	C
1829 mm (72")	C	C	C	C	C

C – Compatible.

**CAT WORK TOOL COMPATIBILITY**

	257D	277D	287D	297D2	297D2 XHP
<b>Carriage</b>	C	C	C	C	C
<b>Pallet Forks</b>					
910 mm (36") Tines	C	C	C	C	C
1070 mm (42") Tines	C	C	C	C	C
1220 mm (48") Tines	C	C	C	C	C
<b>Utility Grapple Forks</b>					
1676 mm (66")	C	C	C	C	C
1829 mm (72")	C	C	C	C	C
<b>Utility Forks</b>					
1676 mm (66")	C	C	C	C	C
1829 mm (72")	C	C	C	C	C
<b>Angle Blades</b>					
1829 mm (72")	C	C	C	C	C
2134 mm (84")	C	C	C	C	C
<b>Dozer Blades</b>					
2000 mm (79")	C	C	C	C	C
2337 mm (92")	C	C	C	C	C
<b>A14B Auger</b>	C	C	C	C	C
<b>A19B Auger</b>	C	C	C	C	C
<b>A26B Auger</b>	C	C	C	C	C
<b>BH150 Backhoe</b>	C	C	C	C	C
<b>BH160 Backhoe</b>	X	C	C	C	C,R
<b>BR160 Brushcutter</b>	X	X	X	X	X
<b>BR166 Brushcutter</b>	C	C	C	C	C
<b>BR172 Brushcutter</b>	C	C	C	C	C
<b>BR272 Brushcutter</b>	X	X	X	X	X
<b>BR378 Brushcutter</b>	X	C	C	C	C
<b>BP115C Pickup Broom</b>	C	C	C	C	C
<b>BP118C Pickup Broom</b>	C	C	C	C	C
<b>BA118C Angle Broom</b>	C	C	C	C	C
<b>BU115 Utility Broom</b>	C	C	C	C	C
<b>BU118 Utility Broom</b>	C*	C	C	C	C
<b>PC104B Cold Planer</b>	C	C	C	C	C
<b>PC205B Cold Planer</b>	C	C	C	C	C
<b>PC305B Cold Planer</b>	C	C	C	C	C
<b>PC306B Cold Planer</b>	C	C	C	C	C
<b>PC306B XD Cold Planer</b>	X	C*	C	C	C
<b>PC310B Cold Planer</b>	X	C	C	C	C
<b>PC310B XD Cold Planer</b>	X	X	C*	C*	C*
<b>PC408B Cold Planer</b>	X	X	X	X	C
<b>PC412B Cold Planer</b>	X	X	X	X	C

C – Compatible.

C\* – Compatible but Lift Restrictions Apply.

R – Machine must have limited options installed to avoid exceeding the maximum total machine rated capacity. Refer to the Operation and Maintenance Manual for the specific Work Tool for details.

X – Not Compatible.



## CAT WORK TOOL COMPATIBILITY

	257D	277D	287D	297D2	297D2 XHP
H55E S Hammer	C,D	C,D	C,D	C,D	C,D
H65E S Hammer	C,D	C,D	C,D	C,D	C,D
LR15B Landscape Rake	C*	C	C	C	C
LR18B Landscape Rake	C*	C	C	C	C
LT13B Landscape Tiller	C	C	C	C	C
LT18B Landscape Tiller	C	C	C	C	C
Material Handling Arm	C	C	C	C	C
HM315B Mulcher	X	C	C	C	C
HM415B Mulcher	X	X	X	X	C
PR172 Power Box Rake	C	C	C	C	C
PR184 Power Box Rake	C	C	C	C	C
PR190 Power Box Rake	C	C	C	C	C
S305 Shear	C,D	C,D	C,D	C,D	C,D
Sectional Snow Push 2440 mm (8 ft)	C	C	C	C	C
Sectional Snow Push 3050 mm (10 ft)	C	C	C	C	C
Sectional Snow Push 3660 mm (12 ft)	X	C	C	C	C
Sectional Snow Push 4270 mm (15 ft)	X	X	X	C	C
SR117 Snowblower	X	X	X	X	X
SR118 Snowblower	C	C	C	C	C
SR121 Snowblower	C	C	C	C	C
SR318 Snowblower	C	C	C	C	C
SR321 Snowblower	C	C	C	C	C
SG16B Stump Grinder	C	C	C	C	C
SG18B Stump Grinder	C	C	C	C	C
T6B Trencher	C	C	C	C	C
T9B Trencher	C	C	C	C	C
T15B Trencher	C	C	C	C	C
CV16B Vibratory Compactor	C*	C	C	C	C
CV18B Vibratory Compactor	X	C	C	C	C
SW345B Wheel Saw – 80 mm (3")	C^	C	C	C	C
SW345B Wheel Saw – 130 mm (5")	C*	C	C	C	C
SW360B Wheel Saw – 80 mm (3")	X	C^	C^	C	C
SW360B Wheel Saw – 100 mm (4")	X	C^	C^	C	C
SW360B Wheel Saw – 130 mm (5")	X	C^	C^	C	C
SW360B Wheel Saw – 150 mm (6")	X	C^	C^	C	C
SW360B Wheel Saw – 200 mm (8")	X	C^	C^	C	C
SW460B Wheel Saw – 80 mm (3")	X	X	X	X	C
SW460B Wheel Saw – 150 mm (6")	X	X	X	X	C
SW460B Wheel Saw – 200 mm (8")	X	X	X	X	C
SW380B Wheel Saw – 250 mm (10")	X	C^	C^	C	C
SW480B Wheel Saw – 250 mm (10")	X	X	X	X	C

C – Compatible.

C\* – Compatible but Lift Restrictions Apply.

C^ – Compatible but Lift Restrictions Apply and Maximum Machine Counterweights Required.

D – European Union Restrictions Apply; Refer to Operation Maintenance Manual, "Safety Section: Worktools: Demolition."

X – Not Compatible.

MODEL	239D		249D		259D	
Flywheel Power:						
Gross (SAE J1995)	50.1 kW	<b>67.1 hp</b>	50.1 kW	<b>67.1 hp</b>	55.4 kW	<b>74.3 hp</b>
Net (SAE 1349)*	49.1 kW	<b>65.8 hp</b>	49.1 kW	<b>65.8 hp</b>	54.6 kW	<b>73.2 hp</b>
Net (SAE 1349)†	—		—		54.2 kW	<b>72.7 hp</b>
Net (SAE 1349)#	44.0 kW	<b>58.9 hp</b>	44.0 kW	<b>58.9 hp</b>	53.8 kW	<b>72.1 hp</b>
Engine Model	<b>C2.2 CRDI</b>		<b>C2.2 CRDI</b>		<b>C3.3B DIT</b>	
Rated Engine RPM	<b>2800</b>		<b>2800</b>		<b>2400</b>	
Bore	84 mm	<b>3.3"</b>	84 mm	<b>3.3"</b>	94 mm	<b>3.7"</b>
Stroke	100 mm	<b>3.9"</b>	100 mm	<b>3.9"</b>	120 mm	<b>4.7"</b>
Displacement	2.2 L	<b>134.3 in<sup>3</sup></b>	2.2 L	<b>134.3 in<sup>3</sup></b>	3.3 L	<b>203 in<sup>3</sup></b>
No. Cylinders	<b>4</b>		<b>4</b>		<b>4</b>	
One Speed Forward	11.2 km/h	<b>7.0 mph</b>	11.2 km/h	<b>7.0 mph</b>	0-9.5 km/h	<b>0-5.9 mph</b>
Two Speed Forward	—		—		0-13.7 km/h	<b>0-8.5 mph</b>
One Speed Reverse	11.2 km/h	<b>7.0 mph</b>	11.2 km/h	<b>7.0 mph</b>	0-9.5 km/h	<b>0-5.9 mph</b>
Two Speed Reverse	—		—		0-13.7 km/h	<b>0-8.5 mph</b>
Hydraulic Cycle Time, Empty Bucket:	<b>Seconds</b>		<b>Seconds</b>		<b>Seconds</b>	
Raise	<b>2.6</b>		<b>4.4</b>		<b>4.4</b>	
Dump	<b>2.1</b>		<b>2.1</b>		<b>2.4</b>	
Lower (Empty, Float Down)	<b>2.9</b>		<b>6.6</b>		<b>3.6</b>	
Total	<b>7.6</b>		<b>13.1</b>		<b>10.4</b>	
Tread Width (per side)	320 mm	<b>12.6"</b>	320 mm	<b>12.6"</b>	320 mm	<b>12.6"</b>
	400 mm	<b>15.7"</b>	400 mm	<b>15.7"</b>	400 mm	<b>15.7"</b>
Width Over Tracks	1676 mm	<b>66.0"</b>	1676 mm	<b>66.0"</b>	1676 mm	<b>66"</b>
	1756 mm	<b>69.1"</b>	1756 mm	<b>69.1"</b>	1755 mm	<b>69"</b>
Ground Clearance	195 mm	<b>7.7"</b>	195 mm	<b>7.7"</b>	226 mm	<b>8.9"</b>
Fuel Tank Capacity	59 L	<b>15.5 U.S. gal</b>	59 L	<b>15.5 U.S. gal</b>	105 L	<b>27.7 U.S. gal</b>
Hydraulic Tank Capacity	34 L	<b>9.0 U.S. gal</b>	34 L	<b>9.0 U.S. gal</b>	39 L	<b>10.3 U.S. gal</b>
Hydraulic System Capacity (includes tank)	45 L	<b>11.9 U.S. gal</b>	45 L	<b>11.9 U.S. gal</b>	50 L	<b>13.2 U.S. gal</b>
Hydraulic Pump Capacity, Standard	69 L/min	<b>18 gpm</b>	69 L/min	<b>18 gpm</b>	76 L/min	<b>20 gpm</b>
Hydraulic Pressure, Standard	23 000 kPa	<b>3336 psi</b>	23 000 kPa	<b>3336 psi</b>	23 000 kPa	<b>3335 psi</b>
Hydraulic Pump Capacity, High Flow/XPS	99 L/min	<b>26 gpm</b>	99 L/min	<b>26 gpm</b>	112 L/min	<b>30 gpm</b>
Hydraulic Pressure, High Flow/XPS	23 000 kPa	<b>3336 psi</b>	23 000 kPa	<b>3336 psi</b>	23 000 kPa	<b>3335 psi</b>

\*Meets Tier 4 Final, Stage IIIB, Japan 2011 (Tier 4 Interim) emission standards.

†Meets Tier 4 Interim, Stage IIIA, Japan 2006 (Tier 3) equivalent emission standards OR Tier 2, Stage II, Japan 2001 (Tier 2) equivalent emission standards.

#Meets Tier 4 Interim, Stage IIIA, Japan 2006 (Tier 3) equivalent emission standards OR Tier 2, Stage II, Japan 2001 (Tier 2) equivalent emission standards.

MODEL	279D		289D		299D2	
Flywheel Power:						
Gross (SAE J1995)	55.4 kW	<b>74.3 hp</b>	55.4 kW	<b>74.3 hp</b>	73.2 kW	<b>98.2 hp</b>
Net (SAE 1349)*	54.6 kW	<b>73.2 hp</b>	54.6 kW	<b>73.2 hp</b>	70.6 kW	<b>94.7 hp</b>
Net (SAE 1349)†	54.0 kW	<b>72.4 hp</b>	54.0 kW	<b>72.4 hp</b>	—	—
Net (SAE 1349)#	53.6 kW	<b>71.8 hp</b>	53.6 kW	<b>71.8 hp</b>	—	—
Engine Model	<b>C3.3B DIT</b>		<b>C3.3B DIT</b>		<b>C3.8 DIT</b>	
Rated Engine RPM	<b>2400</b>		<b>2400</b>		<b>2400</b>	
Bore	94 mm	<b>3.7"</b>	94 mm	<b>3.7"</b>	100 mm	<b>3.9"</b>
Stroke	120 mm	<b>4.7"</b>	120 mm	<b>4.7"</b>	120 mm	<b>4.7"</b>
Displacement	3.3 L	<b>203 in³</b>	3.3 L	<b>203 in³</b>	3.8 L	<b>231.9 in³</b>
No. Cylinders	<b>4</b>		<b>4</b>		<b>4</b>	
One Speed Forward	0-7.2 km/h	<b>0-4.5 mph</b>	0-7.2 km/h	<b>0-4.5 mph</b>	8.4 km/h	<b>5.2 mph</b>
Two Speed Forward	0-11.3 km/h	<b>0-7.0 mph</b>	0-11.3 km/h	<b>0-7.0 mph</b>	13.5 km/h	<b>8.4 mph</b>
One Speed Reverse	0-7.2 km/h	<b>0-4.5 mph</b>	0-7.2 km/h	<b>0-4.5 mph</b>	8.4 km/h	<b>5.2 mph</b>
Two Speed Reverse	0-11.3 km/h	<b>0-7.0 mph</b>	0-11.3 km/h	<b>0-7.0 mph</b>	13.5 km/h	<b>8.4 mph</b>
Hydraulic Cycle Time, Empty Bucket:	<b>Seconds</b>		<b>Seconds</b>		<b>Seconds</b>	
Raise	<b>3.1</b>		<b>4.6</b>		<b>5.2</b>	
Dump	<b>2.5</b>		<b>2.3</b>		<b>2.3</b>	
Lower (Empty, Float Down)	<b>4.0</b>		<b>4.0</b>		<b>4.6</b>	
Total	<b>9.6</b>		<b>10.9</b>		<b>12.1</b>	
Tread Width (per side)	400 mm	<b>15.7"</b>	400 mm	<b>15.7"</b>	400 mm	<b>15.7"</b>
	450 mm	<b>17.7"</b>	450 mm	<b>17.7"</b>	450 mm	<b>17.7"</b>
Width Over Tracks	1931 mm	<b>76"</b>	1931 mm	<b>76"</b>	1931 mm	<b>76.0"</b>
	1981 mm	<b>78"</b>	1981 mm	<b>78"</b>	1981 mm	<b>78.0"</b>
Ground Clearance	226 mm	<b>8.9"</b>	226 mm	<b>8.9"</b>	245 mm	<b>9.6"</b>
Fuel Tank Capacity	94 L	<b>24.8 U.S. gal</b>	94 L	<b>24.8 U.S. gal</b>	122 L	<b>32.2 U.S. gal</b>
Hydraulic Tank Capacity	39 L	<b>10.3 U.S. gal</b>	39 L	<b>10.3 U.S. gal</b>	39 L	<b>10.3 U.S. gal</b>
Hydraulic System Capacity (includes tank)	52 L	<b>13.7 U.S. gal</b>	52 L	<b>13.7 U.S. gal</b>	55 L	<b>14.5 U.S. gal</b>
Hydraulic Pump Capacity, Standard	86 L/min	<b>23 gpm</b>	86 L/min	<b>23 gpm</b>	86 L/min	<b>23 gpm</b>
Hydraulic Pressure, Standard	23 000 kPa	<b>3335 psi</b>	23 000 kPa	<b>3335 psi</b>	23 000 kPa	<b>3336 psi</b>
Hydraulic Pump Capacity, High Flow/XPS	121 L/min	<b>32 gpm</b>	121 L/min	<b>32 gpm</b>	121 L/min	<b>32 gpm</b>
Hydraulic Pressure, High Flow/XPS	28 000 kPa	<b>4061 psi</b>	28 000 kPa	<b>4061 psi</b>	28 000 kPa	<b>4061 psi</b>

\*Meets Tier 4 Final, Stage IIIB, Japan 2011 (Tier 4 Interim) emission standards.

†Meets Tier 4 Interim, Stage IIIA, Japan 2006 (Tier 3) equivalent emission standards OR Tier 2, Stage II, Japan 2001 (Tier 2) equivalent emission standards.

#Meets Tier 4 Interim, Stage IIIA, Japan 2006 (Tier 3) equivalent emission standards OR Tier 2, Stage II, Japan 2001 (Tier 2) equivalent emission standards.

Specifications  
 ● 299D2 XHP/299D2 (Steel Track)/  
 299D2 XHP (Steel Track)

**Compact Track Loaders**

MODEL	299D2 XHP		299D2 (Steel Track)		299D2 XHP (Steel Track)	
Flywheel Power:						
Gross (SAE J1995)	82.0 kW	<b>110.0 hp</b>	73.2 kW	<b>98.2 hp</b>	82.0 kW	<b>110.0 hp</b>
Net (SAE 1349)*	79.0 kW	<b>105.9 hp</b>	70.6 kW	<b>94.7 hp</b>	79.0 kW	<b>105.9 hp</b>
Engine Model	<b>C3.8 DITA</b>		<b>C3.8 DIT</b>		<b>C3.8 DITA</b>	
Rated Engine RPM	<b>2400</b>		<b>2400</b>		<b>2400</b>	
Bore	100 mm	<b>3.9"</b>	100 mm	<b>3.9"</b>	100 mm	<b>3.9"</b>
Stroke	120 mm	<b>4.7"</b>	120 mm	<b>4.7"</b>	120 mm	<b>4.7"</b>
Displacement	3.8 L	<b>231.9 in<sup>3</sup></b>	3.8 L	<b>231.9 in<sup>3</sup></b>	3.8 L	<b>231.9 in<sup>3</sup></b>
No. Cylinders	<b>4</b>		<b>4</b>		<b>4</b>	
One Speed Forward	8.4 km/h	<b>5.2 mph</b>	7.8 km/h	<b>4.8 mph</b>	7.8 km/h	<b>4.8 mph</b>
Two Speed Forward	13.5 km/h	<b>8.4 mph</b>	—	—	—	—
One Speed Reverse	8.4 km/h	<b>5.2 mph</b>	7.8 km/h	<b>4.8 mph</b>	7.8 km/h	<b>4.8 mph</b>
Two Speed Reverse	13.5 km/h	<b>8.4 mph</b>	—	—	—	—
Hydraulic CycleTime, Empty Bucket:	<b>Seconds</b>		<b>Seconds</b>		<b>Seconds</b>	
Raise	<b>4.4</b>		<b>5.2</b>		<b>4.4</b>	
Dump	<b>2.0</b>		<b>2.3</b>		<b>2.0</b>	
Lower (Empty, Float Down)	<b>4.7</b>		<b>4.6</b>		<b>4.7</b>	
Total	<b>11.1</b>		<b>12.1</b>		<b>11.1</b>	
Tread Width (per side)	400 mm	<b>15.7"</b>	400 mm	<b>15.7"</b>	400 mm	<b>15.7"</b>
	450 mm	<b>17.7"</b>	450 mm	<b>17.7"</b>	450 mm	<b>17.7"</b>
Width Over Tracks	1931 mm	<b>76.0"</b>	1931 mm	<b>76.0"</b>	1931 mm	<b>76.0"</b>
	1981 mm	<b>78.0"</b>	1981 mm	<b>78.0"</b>	1981 mm	<b>78.0"</b>
Ground Clearance	245 mm	<b>9.6"</b>	245 mm	<b>9.6"</b>	245 mm	<b>9.6"</b>
Fuel Tank Capacity	122 L	<b>32.2 U.S. gal</b>	122 L	<b>32.2 U.S. gal</b>	122 L	<b>32.2 U.S. gal</b>
Hydraulic Tank Capacity	39 L	<b>10.3 U.S. gal</b>	39 L	<b>10.3 U.S. gal</b>	39 L	<b>10.3 U.S. gal</b>
Hydraulic System Capacity (includes tank)	55 L	<b>14.5 U.S. gal</b>	55 L	<b>14.5 U.S. gal</b>	55 L	<b>14.5 U.S. gal</b>
Hydraulic Pump Capacity, Standard	86 L/min	<b>23 gpm</b>	86 L/min	<b>23 gpm</b>	86 L/min	<b>23 gpm</b>
Hydraulic Pressure, Standard	23 000 kPa	<b>3336 psi</b>	23 000 kPa	<b>3336 psi</b>	23 000 kPa	<b>3336 psi</b>
Hydraulic Pump Capacity, High Flow/XPS	—	—	121 L/min	<b>32 gpm</b>	—	—
Hydraulic Pressure, High Flow/XPS	—	—	28 000 kPa	<b>4061 psi</b>	—	—
Hydraulic Pump Capacity, High Flow/XHP	150 L/min	<b>40 gpm</b>	—	—	150 L/min	<b>40 gpm</b>
Hydraulic Pressure, High Flow/XHP	28 000 kPa	<b>4061 psi</b>	—	—	28 000 kPa	<b>4061 psi</b>

\*Meets Tier 4 Final, Stage IIIB, Japan 2011 (Tier 4 Interim) emission standards.

Bucket Type		General Purpose: Bolt-on Edge		Multi-Purpose: Bolt-on Edge	
Bucket Width		1680 mm (66")	1830 mm (72")	1680 mm (66")	1830 mm (72")
Ground Engaging Type		Bolt-on Edge	Bolt-on Edge	Bolt-on Edge	Bolt-on Edge
Bucket Assembly No.		279-5369	279-5373	279-5391	279-5399
Rated bucket capacity	m <sup>3</sup>	0.40	0.44	0.34	0.37
	yd <sup>3</sup>	<b>0.52</b>	<b>0.58</b>	<b>0.44</b>	<b>0.48</b>
Struck capacity	m <sup>3</sup>	0.29	0.31	0.25	0.26
	yd <sup>3</sup>	<b>0.38</b>	<b>0.41</b>	<b>0.33</b>	<b>0.34</b>
Width	mm	1740	1893	1749	1902
	in	<b>68.5</b>	<b>74.5</b>	<b>68.9</b>	<b>74.9</b>
Dump clearance at maximum lift/dump	mm	1979	1978	1964	1962
	in	<b>77.9</b>	<b>77.9</b>	<b>77.3</b>	<b>77.3</b>
Reach at maximum lift/dump	mm	605	607	617	619
	in	<b>23.8</b>	<b>23.9</b>	<b>24.3</b>	<b>24.4</b>
Floor angle at maximum lift/dump	degrees	<b>-50.5</b>	<b>-50.5</b>	<b>-50.8</b>	<b>-50.8</b>
Floor angle at maximum lift/rack back	degrees	<b>85.3</b>	<b>85.3</b>	<b>85.1</b>	<b>85.1</b>
Clearance at maximum lift/level bucket	mm	2612	2611	2598	2596
	in	<b>102.8</b>	<b>102.8</b>	<b>102.3</b>	<b>102.2</b>
Hinge pin height at maximum lift	mm	2822	2822	2818	2817
	in	<b>111.1</b>	<b>111.1</b>	<b>110.9</b>	<b>110.9</b>
Maximum overall height	mm	3720	3720	3721	3720
	in	<b>146.5</b>	<b>146.4</b>	<b>146.5</b>	<b>146.5</b>
Reach at level lift arm/bucket	mm	1442	1443	1302	1458
	in	<b>56.8</b>	<b>56.8</b>	<b>51.3</b>	<b>57.4</b>
Maximum floor angle at minimum lift	degrees	<b>23.0</b>	<b>23.0</b>	<b>22.8</b>	<b>22.7</b>
Dig depth with level bucket	mm	6	5	-7	-8
	in	<b>0.2</b>	<b>0.2</b>	<b>-0.3</b>	<b>-0.3</b>
Overall length with bucket on ground	mm	3316	3315	3321	3320
	in	<b>130.5</b>	<b>130.5</b>	<b>130.7</b>	<b>130.7</b>
Front clearance circle radius (with bucket)	mm	2146	2178	2153	2185
	in	<b>84.5</b>	<b>85.8</b>	<b>84.8</b>	<b>86.0</b>
Tipping load	kg	1729.3	1712.4	1583.4	1561.5
	lb	<b>3812</b>	<b>3775</b>	<b>3491</b>	<b>3442</b>
Breakout force — lift	kg	1393.9	1380.8	1286.0	1267.7
	lb	<b>3073</b>	<b>3044</b>	<b>2835</b>	<b>2795</b>
Breakout force — tilt	kg	1564.5	1555.5	1504.8	1495.4
	lb	<b>3449</b>	<b>3429</b>	<b>3318</b>	<b>3297</b>
Operating weight	kg	3370.9	3386.4	3504.3	3527.1
	lb	<b>7431</b>	<b>7466</b>	<b>7726</b>	<b>7776</b>

Bucket Type		Dirt: Bolt-on Edge	
		1680 mm (66")	1830 mm (72")
Bucket Width			
Ground Engaging Type		Bolt-on Edge	Bolt-on Edge
Bucket Assembly No.		279-5441	285-6090
Rated bucket capacity	m <sup>3</sup>	0.37	0.41
	yd <sup>3</sup>	<b>0.48</b>	<b>0.54</b>
Struck capacity	m <sup>3</sup>	0.27	0.30
	yd <sup>3</sup>	<b>0.35</b>	<b>0.39</b>
Width	mm	1740	1893
	in	<b>68.5</b>	<b>74.5</b>
Dump clearance at maximum lift/dump	mm	2023	2022
	in	<b>79.6</b>	<b>79.6</b>
Reach at maximum lift/dump	mm	572	573
	in	<b>22.5</b>	<b>22.6</b>
Floor angle at maximum lift/dump	degrees	<b>-50.4</b>	<b>-50.5</b>
Floor angle at maximum lift/rack back	degrees	<b>85.4</b>	<b>85.4</b>
Clearance at maximum lift/level bucket	mm	2617	2615
	in	<b>103.0</b>	<b>103.0</b>
Hinge pin height at maximum lift	mm	2823	2823
	in	<b>111.2</b>	<b>111.1</b>
Maximum overall height	mm	3669	3668
	in	<b>144.4</b>	<b>144.4</b>
Reach at level lift arm/bucket	mm	1387	1388
	in	<b>54.6</b>	<b>54.7</b>
Maximum floor angle at minimum lift	degrees	<b>23.1</b>	<b>23.1</b>
Dig depth with level bucket	mm	10	9
	in	<b>0.4</b>	<b>0.4</b>
Overall length with bucket on ground	mm	3263	3263
	in	<b>128.5</b>	<b>128.5</b>
Front clearance circle radius (with bucket)	mm	2101	2134
	in	<b>82.7</b>	<b>84.0</b>
Tipping load	kg	1794.6	1778.3
	lb	<b>3956</b>	<b>3920</b>
Breakout force — lift	kg	1438.4	1424.6
	lb	<b>3171</b>	<b>3141</b>
Breakout force — tilt	kg	1683.8	1674.2
	lb	<b>3712</b>	<b>3691</b>
Operating weight	kg	3348.2	3364.3
	lb	<b>7381</b>	<b>7417</b>

Work Tool		Pallet Fork		
		910 mm (36")	1070 mm (42")	1220 mm (48")
Tine Length				
Carriage Assembly No.		<b>353-1694</b>	<b>353-1696</b>	<b>353-1697</b>
Carriage overall width without step	mm	1160	1160	1160
	in	<b>45.7</b>	<b>45.7</b>	<b>45.7</b>
Carriage step additional width	mm	106	106	106
	in	<b>4.2</b>	<b>4.2</b>	<b>4.2</b>
Carriage height above blade top	mm	926	926	926
	in	<b>36.5</b>	<b>36.5</b>	<b>36.5</b>
Blade surface height at maximum height	mm	2718	2718	2717
	in	<b>107.0</b>	<b>107.0</b>	<b>107.0</b>
Shank front face reach at maximum height	mm	475	477	479
	in	<b>18.7</b>	<b>18.8</b>	<b>18.9</b>
Blade surface height at level lift arms	mm	1426	1425	1422
	in	<b>56.1</b>	<b>56.1</b>	<b>56.0</b>
Shank front face reach at level lift arms	mm	816	817	819
	in	<b>32.1</b>	<b>32.2</b>	<b>32.2</b>
Blade surface height at minimum lift	mm	100	110	109
	in	<b>4.0</b>	<b>4.3</b>	<b>4.3</b>
Shank front face reach at minimum lift	mm	418	418	419
	in	<b>16.5</b>	<b>16.5</b>	<b>16.5</b>
Overall length at minimum lift, level tine	mm	3607	3767	3917
	in	<b>142.0</b>	<b>148.3</b>	<b>154.2</b>
Tipping load	kg	1470.0	1390.3	1321.4
	lb	<b>3241</b>	<b>3065</b>	<b>2913</b>
Operating weight	kg	3292.3	3302.6	3312.2
	lb	<b>7258</b>	<b>7281</b>	<b>7302</b>

Bucket Type		General Purpose: Bolt-on Edge		Multi-Purpose: Bolt-on Edge	
Bucket Width		1680 mm (66")	1830 mm (72")	1680 mm (66")	1830 mm (72")
Ground Engaging Type		Bolt-on Edge	Bolt-on Edge	Bolt-on Edge	Bolt-on Edge
Bucket Assembly No.		279-5369	279-5373	279-5391	279-5399
Rated bucket capacity	m <sup>3</sup>	0.40	0.44	0.34	0.37
	yd <sup>3</sup>	<b>0.52</b>	<b>0.58</b>	<b>0.44</b>	<b>0.48</b>
Struck capacity	m <sup>3</sup>	0.29	0.31	0.25	0.26
	yd <sup>3</sup>	<b>0.38</b>	<b>0.41</b>	<b>0.33</b>	<b>0.34</b>
Width	mm	1740	1893	1749	1902
	in	<b>68.5</b>	<b>74.5</b>	<b>68.9</b>	<b>74.9</b>
Dump clearance at maximum lift/dump	mm	2175	2174	2158	2156
	in	<b>85.6</b>	<b>85.6</b>	<b>85.0</b>	<b>84.9</b>
Reach at maximum lift/dump	mm	774	775	788	790
	in	<b>30.5</b>	<b>30.5</b>	<b>31.0</b>	<b>31.1</b>
Floor angle at maximum lift/dump	degrees	<b>-48.2</b>	<b>-48.2</b>	<b>-48.5</b>	<b>-48.5</b>
Floor angle at maximum lift/rack back	degrees	<b>87.5</b>	<b>87.4</b>	<b>87.2</b>	<b>87.1</b>
Clearance at maximum lift/level bucket	mm	2793	2791	2776	2774
	in	<b>110.0</b>	<b>109.9</b>	<b>109.3</b>	<b>109.2</b>
Hinge pin height at maximum lift	mm	3001	3000	2995	2994
	in	<b>118.2</b>	<b>118.1</b>	<b>117.9</b>	<b>117.9</b>
Maximum overall height	mm	3909	3908	3909	3908
	in	<b>153.9</b>	<b>153.9</b>	<b>153.9</b>	<b>153.8</b>
Reach at level lift arm/bucket	mm	1403	1470	1454	1420
	in	<b>55.2</b>	<b>57.9</b>	<b>57.2</b>	<b>55.9</b>
Maximum floor angle at minimum lift	degrees	<b>26.3</b>	<b>26.2</b>	<b>26.0</b>	<b>25.9</b>
Dig depth with level bucket	mm	11	10	-2	-4
	in	<b>0.4</b>	<b>0.4</b>	<b>-0.1</b>	<b>-0.1</b>
Overall length with bucket on ground	mm	3316	3316	3321	3321
	in	<b>130.6</b>	<b>130.6</b>	<b>130.8</b>	<b>130.7</b>
Front clearance circle radius (with bucket)	mm	2136	2168	2143	2175
	in	<b>84.1</b>	<b>85.4</b>	<b>84.4</b>	<b>85.6</b>
Tipping load	kg	1942.6	1925.8	1793.8	1772.0
	lb	<b>4283</b>	<b>4246</b>	<b>3955</b>	<b>3907</b>
Breakout force — lift	kg	1605.8	1592.6	1497.3	1479.0
	lb	<b>3540</b>	<b>3511</b>	<b>3301</b>	<b>3261</b>
Breakout force — tilt	kg	1562.1	1553.0	1502.3	1492.9
	lb	<b>3444</b>	<b>3424</b>	<b>3312</b>	<b>3291</b>
Operating weight	kg	3550.3	3565.8	3683.7	3706.5
	lb	<b>7827</b>	<b>7861</b>	<b>8121</b>	<b>8171</b>



Bucket Type		Dirt: Bolt-on Edge	
		1680 mm (66")	1830 mm (72")
Bucket Width			
Ground Engaging Type		Bolt-on Edge	Bolt-on Edge
Bucket Assembly No.		279-5441	285-6090
Rated bucket capacity	m <sup>3</sup>	0.37	0.41
	yd <sup>3</sup>	<b>0.48</b>	<b>0.54</b>
Struck capacity	m <sup>3</sup>	0.27	0.30
	yd <sup>3</sup>	<b>0.35</b>	<b>0.39</b>
Width	mm	1740	1893
	in	<b>68.5</b>	<b>74.5</b>
Dump clearance at maximum lift/dump	mm	2218	2217
	in	<b>87.3</b>	<b>87.3</b>
Reach at maximum lift/dump	mm	738	740
	in	<b>29.1</b>	<b>29.1</b>
Floor angle at maximum lift/dump	degrees	<b>-48.1</b>	<b>-48.2</b>
Floor angle at maximum lift/rack back	degrees	<b>87.5</b>	<b>87.5</b>
Clearance at maximum lift/level bucket	mm	2797	2796
	in	<b>110.1</b>	<b>110.1</b>
Hinge pin height at maximum lift	mm	3003	3002
	in	<b>118.2</b>	<b>118.2</b>
Maximum overall height	mm	3858	3857
	in	<b>151.9</b>	<b>151.8</b>
Reach at level lift arm/bucket	mm	1348	1350
	in	<b>53.1</b>	<b>53.1</b>
Maximum floor angle at minimum lift	degrees	<b>25.9</b>	<b>26.3</b>
Dig depth with level bucket	mm	15	14
	in	<b>0.6</b>	<b>0.5</b>
Overall length with bucket on ground	mm	3264	3263
	in	<b>128.5</b>	<b>128.5</b>
Front clearance circle radius (with bucket)	mm	2092	2125
	in	<b>82.4</b>	<b>83.7</b>
Tipping load	kg	2013.0	1996.8
	lb	<b>4438</b>	<b>4402</b>
Breakout force — lift	kg	1653.5	1639.7
	lb	<b>3645</b>	<b>3615</b>
Breakout force — tilt	kg	1681.2	1671.6
	lb	<b>3706</b>	<b>3685</b>
Operating weight	kg	3527.6	3543.7
	lb	<b>7777</b>	<b>7812</b>

Work Tool		Pallet Fork		
		910 mm (36")	1070 mm (42")	1220 mm (48")
<b>Tine Length</b>		<b>910 mm (36")</b>	<b>1070 mm (42")</b>	<b>1220 mm (48")</b>
<b>Carriage Assembly No.</b>		<b>353-1694</b>	<b>353-1696</b>	<b>353-1697</b>
Carriage overall width without step	mm	1160	1160	1160
	in	<b>45.7</b>	<b>45.7</b>	<b>45.7</b>
Carriage step additional width	mm	106	106	106
	in	<b>4.2</b>	<b>4.2</b>	<b>4.2</b>
Carriage height above blade top	mm	926	926	926
	in	<b>36.5</b>	<b>36.5</b>	<b>36.5</b>
Blade surface height at maximum height	mm	2901	2902	2900
	in	<b>114.2</b>	<b>114.2</b>	<b>114.2</b>
Shank front face reach at maximum height	mm	608	610	612
	in	<b>23.9</b>	<b>24.0</b>	<b>24.1</b>
Blade surface height at level lift arms	mm	1580	1580	1578
	in	<b>62.2</b>	<b>62.2</b>	<b>62.1</b>
Shank front face reach at level lift arms	mm	776	777	779
	in	<b>30.5</b>	<b>30.6</b>	<b>30.7</b>
Blade surface height at minimum lift	mm	118	118	486
	in	<b>4.6</b>	<b>4.7</b>	<b>19.1</b>
Shank front face reach at minimum lift	mm	416	416	399
	in	<b>16.4</b>	<b>16.4</b>	<b>15.7</b>
Overall length at minimum lift, level tine	mm	3607	3767	3900
	in	<b>142.0</b>	<b>148.3</b>	<b>153.5</b>
Tipping load	kg	1640.5	1552.7	1476.8
	lb	<b>3617</b>	<b>3423</b>	<b>3256</b>
Operating weight	kg	3471.7	3482.0	3491.6
	lb	<b>7654</b>	<b>7676</b>	<b>7698</b>

Bucket Type		General Purpose: Bolt-on Edge		Multi-Purpose: Bolt-on Edge	
Bucket Width		1680 mm (66")	1830 mm (72")	1680 mm (66")	1830 mm (72")
Ground Engaging Type		Bolt-on Edge	Bolt-on Edge	Bolt-on Edge	Bolt-on Edge
Bucket Assembly No.		279-5369	279-5373	279-5391	279-5399
Rated bucket capacity	m <sup>3</sup>	0.40	0.44	0.34	0.37
	yd <sup>3</sup>	<b>0.52</b>	<b>0.58</b>	<b>0.44</b>	<b>0.48</b>
Struck capacity	m <sup>3</sup>	0.29	0.31	0.25	0.26
	yd <sup>3</sup>	<b>0.38</b>	<b>0.41</b>	<b>0.33</b>	<b>0.34</b>
Width	mm	1740	1893	1749	1902
	in	<b>68.5</b>	<b>74.5</b>	<b>68.9</b>	<b>74.9</b>
Dump clearance at maximum lift/dump	mm	2420	2418	2404	2403
	in	<b>95.3</b>	<b>95.2</b>	<b>94.7</b>	<b>94.6</b>
Reach at maximum lift/dump	mm	653	654	666	668
	in	<b>25.7</b>	<b>25.8</b>	<b>26.2</b>	<b>26.3</b>
Floor angle at maximum lift/dump	degrees	<b>-38.8</b>	<b>-38.8</b>	<b>-39.1</b>	<b>-39.1</b>
Floor angle at maximum lift/rack back	degrees	<b>83.9</b>	<b>83.9</b>	<b>84.1</b>	<b>84.2</b>
Clearance at maximum lift/level bucket	mm	2965	2964	2956	2955
	in	<b>116.7</b>	<b>116.7</b>	<b>116.4</b>	<b>116.3</b>
Hinge pin height at maximum lift	mm	3174	3174	3169	3168
	in	<b>125.0</b>	<b>124.9</b>	<b>124.8</b>	<b>124.7</b>
Maximum overall height	mm	4135	4134	4136	4135
	in	<b>162.8</b>	<b>162.8</b>	<b>162.8</b>	<b>162.8</b>
Reach at level lift arm/bucket	mm	1478	1479	1492	1493
	in	<b>58.2</b>	<b>58.2</b>	<b>58.7</b>	<b>58.8</b>
Maximum floor angle at minimum lift	degrees	<b>23.0</b>	<b>23.0</b>	<b>23.0</b>	<b>23.0</b>
Dig depth with level bucket	mm	-7	-8	-16	-17
	in	<b>-0.3</b>	<b>-0.3</b>	<b>-0.6</b>	<b>-0.7</b>
Overall length with bucket on ground	mm	3777	3777	3783	3783
	in	<b>148.7</b>	<b>148.7</b>	<b>148.9</b>	<b>148.9</b>
Front clearance circle radius (with bucket)	mm	2251	2281	2253	2284
	in	<b>88.6</b>	<b>89.8</b>	<b>88.7</b>	<b>89.9</b>
Tipping load	kg	2450.2	2433.3	2294.5	2272.5
	lb	<b>5402</b>	<b>5364</b>	<b>5059</b>	<b>5010</b>
Breakout force — lift	kg	2007.9	1994.7	1899.0	1880.7
	lb	<b>4427</b>	<b>4398</b>	<b>4187</b>	<b>4146</b>
Breakout force — tilt	kg	2001.3	1992.2	1940.4	1930.8
	lb	<b>4412</b>	<b>4392</b>	<b>4278</b>	<b>4257</b>
Operating weight	kg	4237.5	4253.0	4370.9	4393.7
	lb	<b>9342</b>	<b>9376</b>	<b>9636</b>	<b>9686</b>

Bucket Type		Dirt: Bolt-on Edge	
		1680 mm (66")	1830 mm (72")
Bucket Width			
Ground Engaging Type		Bolt-on Edge	Bolt-on Edge
Bucket Assembly No.		279-5441	285-6090
Rated bucket capacity	m <sup>3</sup>	0.37	0.41
	yd <sup>3</sup>	<b>0.48</b>	<b>0.54</b>
Struck capacity	m <sup>3</sup>	0.27	0.30
	yd <sup>3</sup>	<b>0.35</b>	<b>0.39</b>
Width	mm	1740	1893
	in	<b>68.5</b>	<b>74.5</b>
Dump clearance at maximum lift/dump	mm	2456	2455
	in	<b>96.7</b>	<b>96.7</b>
Reach at maximum lift/dump	mm	611	613
	in	<b>24.1</b>	<b>24.1</b>
Floor angle at maximum lift/dump	degrees	<b>-38.8</b>	<b>-38.8</b>
Floor angle at maximum lift/rack back	degrees	<b>83.8</b>	<b>83.9</b>
Clearance at maximum lift/level bucket	mm	2968	2967
	in	<b>116.9</b>	<b>116.8</b>
Hinge pin height at maximum lift	mm	3175	3175
	in	<b>125.0</b>	<b>125.0</b>
Maximum overall height	mm	4083	4082
	in	<b>160.8</b>	<b>160.7</b>
Reach at level lift arm/bucket	mm	1424	1425
	in	<b>56.1</b>	<b>56.1</b>
Maximum floor angle at minimum lift	degrees	<b>23.0</b>	<b>23.0</b>
Dig depth with level bucket	mm	-3	-4
	in	<b>-0.1</b>	<b>-0.2</b>
Overall length with bucket on ground	mm	3725	3724
	in	<b>146.6</b>	<b>146.6</b>
Front clearance circle radius (with bucket)	mm	2204	2235
	in	<b>86.8</b>	<b>88.0</b>
Tipping load	kg	2535.1	2519.2
	lb	<b>5589</b>	<b>5554</b>
Breakout force — lift	kg	2062.0	2048.2
	lb	<b>4546</b>	<b>4515</b>
Breakout force — tilt	kg	2148.2	2138.5
	lb	<b>4736</b>	<b>4715</b>
Operating weight	kg	4214.8	4230.9
	lb	<b>9292</b>	<b>9327</b>

Work Tool		Pallet Fork		
		910 mm (36")	1070 mm (42")	1220 mm (48")
Tine Length				
Carriage Assembly No.		<b>353-1694</b>	<b>353-1696</b>	<b>353-1697</b>
Carriage overall width without step	mm	1160	1160	1160
	in	<b>45.7</b>	<b>45.7</b>	<b>45.7</b>
Carriage step additional width	mm	106	106	106
	in	<b>4.2</b>	<b>4.2</b>	<b>4.2</b>
Carriage height above blade top	mm	926	926	926
	in	<b>36.5</b>	<b>36.5</b>	<b>36.5</b>
Blade surface height at maximum height	mm	2975	2974	2973
	in	<b>117.1</b>	<b>117.1</b>	<b>117.0</b>
Shank front face reach at maximum height	mm	516	518	521
	in	<b>20.3</b>	<b>20.4</b>	<b>20.5</b>
Blade surface height at level lift arms	mm	1426	1425	1424
	in	<b>56.1</b>	<b>56.1</b>	<b>56.0</b>
Shank front face reach at level lift arms	mm	754	755	757
	in	<b>29.7</b>	<b>29.7</b>	<b>29.8</b>
Blade surface height at minimum lift	mm	92	92	90
	in	<b>3.6</b>	<b>3.6</b>	<b>3.6</b>
Shank front face reach at minimum lift	mm	452	453	453
	in	<b>17.8</b>	<b>17.8</b>	<b>17.8</b>
Overall length at minimum lift, level tine	mm	3851	4011	4161
	in	<b>151.6</b>	<b>157.9</b>	<b>163.8</b>
Tipping load	kg	2027.6	1920.2	1827.7
	lb	<b>4470</b>	<b>4233</b>	<b>4029</b>
Operating weight	kg	3958.1	3968.4	3978.0
	lb	<b>8726</b>	<b>8749</b>	<b>8770</b>

Bucket Type		General Purpose: Bolt-on Edge	
		1981 mm (78")	2134 mm (84")
Bucket Width		1981 mm (78")	2134 mm (84")
Tire Size		12 x 16.5	12 x 16.5
Ground Engaging Type		Bolt-on Edge	Bolt-on Edge
Bucket Assembly No.		279-5377	296-8192
Rated bucket capacity	m <sup>3</sup>	0.48	0.63
	yd <sup>3</sup>	0.63	0.82
Struck capacity	m <sup>3</sup>	0.32	0.59
	yd <sup>3</sup>	0.42	0.77
Width	mm	2045	2198
	in	80.5	86.5
Dump clearance at maximum lift/dump	mm	2427	2365
	in	95.6	93.1
Reach at maximum lift/dump	mm	615	691
	in	24.2	27.2
Floor angle at maximum lift/dump	degrees	-38.4	-38.5
Floor angle at maximum lift/rack back	degrees	96.5	96.4
Clearance at maximum lift/level bucket	mm	2969	2965
	in	116.9	116.7
Hinge pin height at maximum lift	mm	3178	3177
	in	125.1	125.1
Maximum overall height	mm	4140	4230
	in	163.0	166.6
Reach at level lift arm/bucket	mm	1446	1542
	in	56.9	60.7
Maximum floor angle at minimum lift	degrees	26.2	26.2
Dig depth with level bucket	mm	-3	-6
	in	-0.1	-0.2
Overall length with bucket on ground	mm	3779	3872
	in	148.8	152.4
Front clearance circle radius (with bucket)	mm	2331	2445
	in	91.8	96.2
Tipping load	kg	2769.6	2675.0
	lb	6106	5897
Breakout force — lift	kg	2575.6	2463.7
	lb	5678	5431
Breakout force — tilt	kg	2914.2	2594.6
	lb	6425	5720
Operating weight	kg	4542.6	4579.5
	lb	10,015	10,096

Bucket Type		Multi-Purpose: Bolt-on Edge		Dirt: Bolt-on Edge
Bucket Width		1981 mm (78")	2134 mm (84")	1981 mm (78")
Tire Size		12 x 16.5	12 x 16.5	12 x 16.5
Bucket Assembly No.		Bolt-on Edge	Bolt-on Edge	Bolt-on Edge
Bucket Assembly No.		279-5402	296-8057	268-4083
Rated bucket capacity	m <sup>3</sup>	0.40	0.43	0.44
	yd <sup>3</sup>	0.52	0.56	0.58
Struck capacity	m <sup>3</sup>	0.28	0.30	0.32
	yd <sup>3</sup>	0.37	0.39	0.42
Width	mm	2045	2207	2045
	in	80.5	86.9	80.5
Dump clearance at maximum lift/dump	mm	2412	2410	2464
	in	94.9	94.9	97.0
Reach at maximum lift/dump	mm	631	633	574
	in	24.8	24.9	22.6
Floor angle at maximum lift/dump	degrees	-38.7	-38.8	-38.4
Floor angle at maximum lift/rack back	degrees	96.2	96.2	96.5
Clearance at maximum lift/level bucket	mm	2960	2959	2972
	in	116.5	116.5	117.0
Hinge pin height at maximum lift	mm	3173	3172	3179
	in	124.9	124.9	125.2
Maximum overall height	mm	4141	4140	4088
	in	163.0	163.0	160.9
Reach at level lift arm/bucket	mm	1461	1462	1392
	in	57.5	57.6	54.8
Maximum floor angle at minimum lift	degrees	26.2	26.2	26.2
Dig depth with level bucket	mm	-12	-13	1
	in	-0.5	-0.5	0.0
Overall length with bucket on ground	mm	3785	3785	3726
	in	149.0	149.0	146.7
Front clearance circle radius (with bucket)	mm	2334	2368	2286
	in	91.9	93.2	90.0
Tipping load	kg	2613.8	2591.3	2860.0
	lb	5762	5713	6305
Breakout force — lift	kg	2456.5	2436.7	2638.5
	lb	5416	5372	5817
Breakout force — tilt	kg	2844.9	2832.7	3119.7
	lb	6272	6245	6878
Operating weight	kg	4688.9	4712.9	4523.5
	lb	10,337	10,390	9972

Work Tool	Pallet Fork		
	910 mm (36")	1070 mm (42")	1220 mm (48")
<b>Tine Length</b>	<b>910 mm (36")</b>	<b>1070 mm (42")</b>	<b>1220 mm (48")</b>
<b>Tire Size</b>	<b>10 x 16.5</b>	<b>10 x 16.5</b>	<b>10 x 16.5</b>
<b>Carriage Assembly No.</b>	<b>353-1694</b>	<b>353-1696</b>	<b>353-1697</b>
Carriage overall width without step	mm	1160	1160
	in	<b>45.7</b>	<b>45.7</b>
Carriage step additional width	mm	106	106
	in	<b>4.2</b>	<b>4.2</b>
Carriage height above blade top	mm	926	926
	in	<b>36.5</b>	<b>36.5</b>
Blade surface height at maximum height	mm	2976	2976
	in	<b>117.2</b>	<b>117.2</b>
Shank front face reach at maximum height	mm	530	531
	in	<b>20.9</b>	<b>20.9</b>
Blade surface height at level lift arms	mm	1396	1396
	in	<b>55.0</b>	<b>54.9</b>
Shank front face reach at level lift arms	mm	918	918
	in	<b>36.1</b>	<b>36.1</b>
Blade surface height at minimum lift	mm	7	7
	in	<b>0.3</b>	<b>0.3</b>
Shank front face reach at minimum lift	mm	369	369
	in	<b>14.5</b>	<b>14.5</b>
Overall length at minimum lift, level tine	mm	4067	4227
	in	<b>160.1</b>	<b>166.4</b>
Tipping load	kg	2198.5	2094.8
	lb	<b>4847</b>	<b>4618</b>
Operating weight	kg	4434.2	4444.5
	lb	<b>9776</b>	<b>9798</b>



Bucket Type		General Purpose: Bolt-on Edge	
		1981 mm (78")	2134 mm (84")
Bucket Width		1981 mm (78")	2134 mm (84")
Tire Size		12 x 16.5	12 x 16.5
Ground Engaging Type		Bolt-on Edge	Bolt-on Edge
Bucket Assembly No.		279-5377	296-8192
Rated bucket capacity	m <sup>3</sup>	0.48	0.63
	yd <sup>3</sup>	0.63	0.82
Struck capacity	m <sup>3</sup>	0.32	0.59
	yd <sup>3</sup>	0.42	0.77
Width	mm	2045	2198
	in	80.5	86.5
Dump clearance at maximum lift/dump	mm	2316	2239
	in	91.2	88.2
Reach at maximum lift/dump	mm	784	845
	in	30.9	33.3
Floor angle at maximum lift/dump	degrees	-50.9	-51.0
Floor angle at maximum lift/rack back	degrees	84.0	83.9
Clearance at maximum lift/level bucket	mm	2971	2967
	in	117.0	116.8
Hinge pin height at maximum lift	mm	3181	3178
	in	125.2	125.1
Maximum overall height	mm	4097	4187
	in	161.3	164.8
Reach at level lift arm/bucket	mm	1340	1436
	in	52.7	56.5
Maximum floor angle at minimum lift	degrees	26.2	26.2
Dig depth with level bucket	mm	-18	-22
	in	-0.7	-0.9
Overall length with bucket on ground	mm	3781	3874
	in	148.8	152.5
Front clearance circle radius (with bucket)	mm	2331	2445
	in	91.8	96.2
Tipping load	kg	3203.3	3093.0
	lb	7062	6819
Breakout force — lift	kg	2378.3	2278.4
	lb	5243	5023
Breakout force — tilt	kg	2916.6	2596.8
	lb	6430	5725
Operating weight	kg	4821.0	4857.9
	lb	10,628	10,710

Bucket Type		Multi-Purpose: Bolt-on Edge		Dirt: Bolt-on Edge
Bucket Width		1981 mm (78")	2134 mm (84")	1981 mm (78")
Tire Size		12 x 16.5	12 x 16.5	12 x 16.5
Bucket Assembly No.		Bolt-on Edge	Bolt-on Edge	Bolt-on Edge
Bucket Assembly No.		279-5402	296-8057	268-4083
Rated bucket capacity	m <sup>3</sup>	0.40	0.43	0.44
	yd <sup>3</sup>	0.52	0.56	0.58
Struck capacity	m <sup>3</sup>	0.28	0.30	0.32
	yd <sup>3</sup>	0.37	0.39	0.42
Width	mm	2045	2207	2045
	in	80.5	86.9	80.5
Dump clearance at maximum lift/dump	mm	2299	2298	2360
	in	90.5	90.5	92.9
Reach at maximum lift/dump	mm	797	799	751
	in	31.4	31.4	29.6
Floor angle at maximum lift/dump	degrees	-51.2	-51.2	-50.9
Floor angle at maximum lift/rack back	degrees	83.7	83.6	84.0
Clearance at maximum lift/level bucket	mm	2960	2959	2974
	in	116.6	116.5	117.1
Hinge pin height at maximum lift	mm	3174	3172	3182
	in	124.9	124.9	125.3
Maximum overall height	mm	4095	4094	4046
	in	161.2	161.2	159.3
Reach at level lift arm/bucket	mm	1355	1356	1286
	in	53.3	53.4	50.6
Maximum floor angle at minimum lift	degrees	26.2	26.2	26.2
Dig depth with level bucket	mm	-27	-28	-15
	in	-1.1	-1.1	-0.6
Overall length with bucket on ground	mm	3786	3786	3728
	in	149.1	149.1	146.8
Front clearance circle radius (with bucket)	mm	2334	2368	2286
	in	91.9	93.2	90.0
Tipping load	kg	3038.1	3015.5	3302.6
	lb	6698	6648	7281
Breakout force — lift	kg	2257.4	2237.3	2433.9
	lb	4977	4932	5366
Breakout force — tilt	kg	2847.3	2835.1	3122.3
	lb	6277	6250	6883
Operating weight	kg	4967.3	4991.3	4801.9
	lb	10,951	11,004	10,586

Work Tool		Pallet Fork		
Tine Length		910 mm (36")	1070 mm (42")	1220 mm (48")
Tire Size		10 x 16.5	10 x 16.5	10 x 16.5
Carriage Assembly No.		353-1694	353-1696	353-1697
Carriage overall width without step	mm	1160	1160	1160
	in	45.7	45.7	45.7
Carriage step additional width	mm	106	106	106
	in	4.2	4.2	4.2
Carriage height above blade top	mm	926	926	926
	in	36.5	36.5	36.5
Blade surface height at maximum height	mm	3076	3076	3074
	in	121.1	121.1	121.0
Shank front face reach at maximum height	mm	665	667	669
	in	26.2	26.3	26.4
Blade surface height at level lift arms	mm	1549	1548	1546
	in	61.0	60.9	60.9
Shank front face reach at level lift arms	mm	715	716	717
	in	28.1	28.2	28.2
Blade surface height at minimum lift	mm	85	84	83
	in	3.3	3.3	3.3
Shank front face reach at minimum lift	mm	381	381	382
	in	15.0	15.0	15.0
Overall length at minimum lift, level tine	mm	4069	4229	4379
	in	160.2	166.5	172.4
Tipping load	kg	2756.1	2619.6	2501.8
	lb	6076	5775	5515
Operating weight	kg	4712.6	4722.9	4732.5
	lb	10,389	10,412	10,433

Bucket Type		General Purpose: Bolt-on Edge	
		1981 mm (78")	2134 mm (84")
Bucket Width			
Ground Engaging Type		Bolt-on Edge	Bolt-on Edge
Bucket Assembly No.		279-5377	296-8192
Rated bucket capacity	m <sup>3</sup>	0.48	0.63
	yd <sup>3</sup>	<b>0.63</b>	<b>0.82</b>
Struck capacity	m <sup>3</sup>	0.32	0.59
	yd <sup>3</sup>	<b>0.42</b>	<b>0.77</b>
Width	mm	2045	2198
	in	<b>80.5</b>	<b>86.5</b>
Dump clearance at maximum lift/dump	mm	2319	2240
	in	<b>91.3</b>	<b>88.2</b>
Reach at maximum lift/dump	mm	890	947
	in	<b>35.0</b>	<b>37.3</b>
Floor angle at maximum lift/dump	degrees	<b>-53.7</b>	<b>-53.8</b>
Floor angle at maximum lift/rack back	degrees	<b>81.3</b>	<b>81.2</b>
Clearance at maximum lift/level bucket	mm	2973	2966
	in	<b>117.1</b>	<b>116.8</b>
Hinge pin height at maximum lift	mm	3205	3203
	in	<b>126.2</b>	<b>126.1</b>
Maximum overall height	mm	4105	4195
	in	<b>161.6</b>	<b>165.2</b>
Reach at level lift arm/bucket	mm	1403	1498
	in	<b>55.2</b>	<b>59.0</b>
Maximum floor angle at minimum lift	degrees	<b>25.0</b>	<b>25.0</b>
Dig depth with level bucket	mm	-73	-79
	in	<b>-2.9</b>	<b>-3.1</b>
Overall length with bucket on ground	mm	4000	4093
	in	<b>157.5</b>	<b>161.1</b>
Front clearance circle radius (with bucket)	mm	2388	2498
	in	<b>94.0</b>	<b>98.4</b>
Tipping load	kg	3944.3	3822.3
	lb	<b>8696</b>	<b>8427</b>
Breakout force — lift	kg	2668.9	2563.7
	lb	<b>5884</b>	<b>5652</b>
Breakout force — tilt	kg	2908.3	2589.2
	lb	<b>6412</b>	<b>5708</b>
Operating weight	kg	5173.5	5210.4
	lb	<b>11,405</b>	<b>11,487</b>

Bucket Type		Multi-Purpose: Bolt-on Edge		Dirt: Bolt-on Edge
		1981 mm (78")	2134 mm (84")	1981 mm (78")
Bucket Width				
Bucket Assembly No.		Bolt-on Edge	Bolt-on Edge	Bolt-on Edge
Bucket Assembly No.		279-5402	296-8057	268-4083
Rated bucket capacity	m <sup>3</sup>	0.40	0.43	0.44
	yd <sup>3</sup>	<b>0.52</b>	<b>0.56</b>	<b>0.58</b>
Struck capacity	m <sup>3</sup>	0.28	0.30	0.32
	yd <sup>3</sup>	<b>0.37</b>	<b>0.39</b>	<b>0.42</b>
Width	mm	2045	2207	2045
	in	<b>80.5</b>	<b>86.9</b>	<b>80.5</b>
Dump clearance at maximum lift/dump	mm	2302	2301	2365
	in	<b>90.6</b>	<b>90.6</b>	<b>93.1</b>
Reach at maximum lift/dump	mm	902	904	859
	in	<b>35.5</b>	<b>35.6</b>	<b>33.8</b>
Floor angle at maximum lift/dump	degrees	<b>-54.0</b>	<b>-54.0</b>	<b>-53.7</b>
Floor angle at maximum lift/rack back	degrees	<b>81.0</b>	<b>81.0</b>	<b>81.3</b>
Clearance at maximum lift/level bucket	mm	2957	2955	2979
	in	<b>116.4</b>	<b>116.3</b>	<b>117.3</b>
Hinge pin height at maximum lift	mm	3198	3197	3206
	in	<b>125.9</b>	<b>125.9</b>	<b>126.2</b>
Maximum overall height	mm	4104	4102	4055
	in	<b>161.6</b>	<b>161.5</b>	<b>159.6</b>
Reach at level lift arm/bucket	mm	1389	1416	1349
	in	<b>54.7</b>	<b>55.8</b>	<b>53.1</b>
Maximum floor angle at minimum lift	degrees	<b>24.8</b>	<b>24.8</b>	<b>25.1</b>
Dig depth with level bucket	mm	-85	-86	-68
	in	<b>-3.3</b>	<b>-3.4</b>	<b>-2.7</b>
Overall length with bucket on ground	mm	4004	4004	3948
	in	<b>157.7</b>	<b>157.6</b>	<b>155.4</b>
Front clearance circle radius (with bucket)	mm	2395	2429	2344
	in	<b>94.3</b>	<b>95.6</b>	<b>92.3</b>
Tipping load	kg	3774.2	3751.6	4068.5
	lb	<b>8321</b>	<b>8271</b>	<b>8969</b>
Breakout force — lift	kg	2547.3	2527.1	2727.6
	lb	<b>5616</b>	<b>5571</b>	<b>6013</b>
Breakout force — tilt	kg	2839.0	2826.8	3113.5
	lb	<b>6259</b>	<b>6232</b>	<b>6864</b>
Operating weight	kg	5319.8	5343.8	5154.4
	lb	<b>11,728</b>	<b>11,781</b>	<b>11,363</b>

Work Tool		Pallet Fork		
		910 mm (36")	1070 mm (42")	1220 mm (48")
<b>Tine Length</b>				
<b>Carriage Assembly No.</b>		<b>353-1694</b>	<b>353-1696</b>	<b>353-1697</b>
Carriage overall width without step	mm	1160	1160	1160
	in	<b>45.7</b>	<b>45.7</b>	<b>45.7</b>
Carriage step additional width	mm	106	106	106
	in	<b>4.2</b>	<b>4.2</b>	<b>4.2</b>
Carriage height above blade top	mm	926	926	926
	in	<b>36.5</b>	<b>36.5</b>	<b>36.5</b>
Blade surface height at maximum height	mm	3080	3077	3072
	in	<b>121.3</b>	<b>121.1</b>	<b>120.9</b>
Shank front face reach at maximum height	mm	811	813	815
	in	<b>31.9</b>	<b>32.0</b>	<b>32.1</b>
Blade surface height at level lift arms	mm	1398	1395	1390
	in	<b>55.1</b>	<b>54.9</b>	<b>54.7</b>
Shank front face reach at level lift arms	mm	778	779	780
	in	<b>30.6</b>	<b>30.7</b>	<b>30.7</b>
Blade surface height at minimum lift	mm	31	29	25
	in	<b>1.2</b>	<b>1.1</b>	<b>1.0</b>
Shank front face reach at minimum lift	mm	402	402	403
	in	<b>15.8</b>	<b>15.8</b>	<b>15.9</b>
Overall length at minimum lift, level tine	mm	4294	4453	4604
	in	<b>169.0</b>	<b>175.3</b>	<b>181.2</b>
Tipping load	kg	3258.7	3096.5	2956.9
	lb	<b>7184</b>	<b>6827</b>	<b>6519</b>
Operating weight	kg	5065.1	5075.4	5085.0
	lb	<b>11,166</b>	<b>11,189</b>	<b>11,210</b>

<b>Bucket Type</b>		<b>General Purpose: Bolt-on Edge</b>	
		<b>1981 mm (78")</b>	<b>2134 mm (84")</b>
<b>Bucket Width</b>		<b>1981 mm (78")</b>	<b>2134 mm (84")</b>
<b>Ground Engaging Type</b>		<b>Bolt-on Edge</b>	<b>Bolt-on Edge</b>
<b>Bucket Assembly No.</b>		<b>279-5377</b>	<b>296-8192</b>
Rated bucket capacity	m <sup>3</sup>	0.48	0.63
	yd <sup>3</sup>	<b>0.63</b>	<b>0.82</b>
Struck capacity	m <sup>3</sup>	0.32	0.59
	yd <sup>3</sup>	<b>0.42</b>	<b>0.77</b>
Width	mm	2045	2198
	in	<b>80.5</b>	<b>86.5</b>
Dump clearance at maximum lift/dump	mm	2319	2240
	in	<b>91.3</b>	<b>88.2</b>
Reach at maximum lift/dump	mm	890	947
	in	<b>35.1</b>	<b>37.3</b>
Floor angle at maximum lift/dump	<b>degrees</b>	<b>-53.7</b>	<b>-53.8</b>
Floor angle at maximum lift/rack back	<b>degrees</b>	<b>81.3</b>	<b>81.2</b>
Clearance at maximum lift/level bucket	mm	2973	2965
	in	<b>117.0</b>	<b>116.7</b>
Hinge pin height at maximum lift	mm	3205	3203
	in	<b>126.2</b>	<b>126.1</b>
Maximum overall height	mm	4105	4195
	in	<b>161.6</b>	<b>165.1</b>
Reach at level lift arm/bucket	mm	1403	1498
	in	<b>55.2</b>	<b>59.0</b>
Maximum floor angle at minimum lift	<b>degrees</b>	<b>25.0</b>	<b>25.0</b>
Dig depth with level bucket	mm	-73	-79
	in	<b>-2.9</b>	<b>-3.1</b>
Overall length with bucket on ground	mm	4000	4093
	in	<b>157.5</b>	<b>161.1</b>
Front clearance circle radius (with bucket)	mm	2388	2498
	in	<b>94.0</b>	<b>98.4</b>
Tipping load	kg	4052.3	3928.2
	lb	<b>8934</b>	<b>8660</b>
Breakout force — lift	kg	2663.7	2558.7
	lb	<b>5872</b>	<b>5641</b>
Breakout force — tilt	kg	2908.3	2589.2
	lb	<b>6412</b>	<b>5708</b>
Operating weight	kg	5324.4	5361.3
	lb	<b>11,738</b>	<b>11,819</b>

Bucket Type		Multi-Purpose: Bolt-on Edge		Dirt: Bolt-on Edge
		1981 mm (78")	2134 mm (84")	1981 mm (78")
Bucket Width				
Bucket Assembly No.		Bolt-on Edge	Bolt-on Edge	Bolt-on Edge
Bucket Assembly No.		279-5402	296-8057	268-4083
Rated bucket capacity	m <sup>3</sup>	0.40	0.43	0.44
	yd <sup>3</sup>	<b>0.52</b>	<b>0.56</b>	<b>0.58</b>
Struck capacity	m <sup>3</sup>	0.28	0.30	0.32
	yd <sup>3</sup>	<b>0.37</b>	<b>0.39</b>	<b>0.42</b>
Width	mm	2045	2207	2045
	in	<b>80.5</b>	<b>86.9</b>	<b>80.5</b>
Dump clearance at maximum lift/dump	mm	2302	2301	2364
	in	<b>90.6</b>	<b>90.6</b>	<b>93.1</b>
Reach at maximum lift/dump	mm	902	904	860
	in	<b>35.5</b>	<b>35.6</b>	<b>33.8</b>
Floor angle at maximum lift/dump	degrees	<b>-54.0</b>	<b>-54.0</b>	<b>-53.7</b>
Floor angle at maximum lift/rack back	degrees	<b>81.0</b>	<b>81.0</b>	<b>81.3</b>
Clearance at maximum lift/level bucket	mm	2957	2955	2978
	in	<b>116.4</b>	<b>116.3</b>	<b>117.3</b>
Hinge pin height at maximum lift	mm	3198	3197	3206
	in	<b>125.9</b>	<b>125.9</b>	<b>126.2</b>
Maximum overall height	mm	4104	4102	4054
	in	<b>161.6</b>	<b>161.5</b>	<b>159.6</b>
Reach at level lift arm/bucket	mm	1415	1416	1349
	in	<b>55.7</b>	<b>55.8</b>	<b>53.1</b>
Maximum floor angle at minimum lift	degrees	<b>24.8</b>	<b>24.8</b>	<b>25.1</b>
Dig depth with level bucket	mm	-85	-87	-69
	in	<b>-3.4</b>	<b>-3.4</b>	<b>-2.7</b>
Overall length with bucket on ground	mm	4004	4004	3948
	in	<b>157.7</b>	<b>157.6</b>	<b>155.4</b>
Front clearance circle radius (with bucket)	mm	2395	2429	2344
	in	<b>94.3</b>	<b>95.6</b>	<b>92.3</b>
Tipping load	kg	3881.1	3858.5	4179.2
	lb	<b>8556</b>	<b>8506</b>	<b>9214</b>
Breakout force — lift	kg	2542.1	2522.0	2722.4
	lb	<b>5604</b>	<b>5560</b>	<b>6002</b>
Breakout force — tilt	kg	2839.0	2826.8	3113.5
	lb	<b>6259</b>	<b>6232</b>	<b>6864</b>
Operating weight	kg	5470.7	5494.7	5305.3
	lb	<b>12,061</b>	<b>12,114</b>	<b>11,696</b>



<b>Work Tool</b>		<b>Pallet Fork</b>		
		<b>910 mm (36")</b>	<b>1070 mm (42")</b>	<b>1220 mm (48")</b>
<b>Tine Length</b>				
<b>Carriage Assembly No.</b>		<b>353-1694</b>	<b>353-1696</b>	<b>353-1697</b>
Carriage overall width without step	<b>mm</b>	1160	1160	1160
	<b>in</b>	<b>45.7</b>	<b>45.7</b>	<b>45.7</b>
Carriage step additional width	<b>mm</b>	106	106	106
	<b>in</b>	<b>4.2</b>	<b>4.2</b>	<b>4.2</b>
Carriage height above blade top	<b>mm</b>	926	926	926
	<b>in</b>	<b>36.5</b>	<b>36.5</b>	<b>36.5</b>
Blade surface height at maximum height	<b>mm</b>	3080	3076	3071
	<b>in</b>	<b>121.2</b>	<b>121.1</b>	<b>120.9</b>
Shank front face reach at maximum height	<b>mm</b>	812	814	816
	<b>in</b>	<b>32.0</b>	<b>32.0</b>	<b>32.1</b>
Blade surface height at level lift arms	<b>mm</b>	1398	1394	1390
	<b>in</b>	<b>55.0</b>	<b>54.9</b>	<b>54.7</b>
Shank front face reach at level lift arms	<b>mm</b>	778	779	780
	<b>in</b>	<b>30.6</b>	<b>30.7</b>	<b>30.7</b>
Blade surface height at minimum lift	<b>mm</b>	31	28	24
	<b>in</b>	<b>1.2</b>	<b>1.1</b>	<b>0.9</b>
Shank front face reach at minimum lift	<b>mm</b>	402	402	403
	<b>in</b>	<b>15.8</b>	<b>15.8</b>	<b>15.9</b>
Overall length at minimum lift, level tine	<b>mm</b>	4293	4453	4604
	<b>in</b>	<b>169.0</b>	<b>175.3</b>	<b>181.2</b>
Tipping load	<b>kg</b>	3345.4	3179.2	3036.1
	<b>lb</b>	<b>7375</b>	<b>7009</b>	<b>6693</b>
Operating weight	<b>kg</b>	5216.0	5226.3	5235.9
	<b>lb</b>	<b>11,499</b>	<b>11,522</b>	<b>11,543</b>

Bucket Type		General Purpose: Bolt-on Edge	
		1981 mm (78")	2134 mm (84")
Bucket Width			
Ground Engaging Type		Bolt-on Edge	Bolt-on Edge
Bucket Assembly No.		279-5377	296-8192
Rated bucket capacity	m <sup>3</sup>	0.48	0.63
	yd <sup>3</sup>	<b>0.63</b>	<b>0.82</b>
Struck capacity	m <sup>3</sup>	0.32	0.59
	yd <sup>3</sup>	<b>0.42</b>	<b>0.77</b>
Width	mm	2045	2198
	in	<b>80.5</b>	<b>86.5</b>
Dump clearance at maximum lift/dump	mm	2310	2232
	in	<b>91.0</b>	<b>87.9</b>
Reach at maximum lift/dump	mm	901	956
	in	<b>35.5</b>	<b>37.6</b>
Floor angle at maximum lift/dump	degrees	<b>-54.0</b>	<b>-54.0</b>
Floor angle at maximum lift/rack back	degrees	<b>81.0</b>	<b>81.0</b>
Clearance at maximum lift/level bucket	mm	2963	2957
	in	<b>116.7</b>	<b>116.4</b>
Hinge pin height at maximum lift	mm	3197	3196
	in	<b>125.9</b>	<b>125.8</b>
Maximum overall height	mm	4096	4187
	in	<b>161.3</b>	<b>164.8</b>
Reach at level lift arm/bucket	mm	1409	1503
	in	<b>55.5</b>	<b>59.2</b>
Maximum floor angle at minimum lift	degrees	<b>24.7</b>	<b>24.7</b>
Dig depth with level bucket	mm	-84	-90
	in	<b>-3.3</b>	<b>-3.5</b>
Overall length with bucket on ground	mm	3997	4089
	in	<b>157.3</b>	<b>161.0</b>
Front clearance circle radius (with bucket)	mm	2388	2498
	in	<b>94.0</b>	<b>98.4</b>
Tipping load	kg	4273.9	4145.3
	lb	<b>9422</b>	<b>9139</b>
Breakout force — lift	kg	2668.9	2563.7
	lb	<b>5884</b>	<b>5652</b>
Breakout force — tilt	kg	2908.3	2589.2
	lb	<b>6412</b>	<b>5708</b>
Operating weight	kg	5527.4	5564.3
	lb	<b>12,186</b>	<b>12,267</b>

Bucket Type		Multi-Purpose: Bolt-on Edge		Dirt: Bolt-on Edge
		1981 mm (78")	2134 mm (84")	1981 mm (78")
Bucket Width		Bolt-on Edge		Bolt-on Edge
Bucket Assembly No.		Bolt-on Edge		Bolt-on Edge
Bucket Assembly No.		279-5402	296-8057	268-4083
Rated bucket capacity	m <sup>3</sup>	0.40	0.43	0.44
	yd <sup>3</sup>	<b>0.52</b>	<b>0.56</b>	<b>0.58</b>
Struck capacity	m <sup>3</sup>	0.28	0.30	0.32
	yd <sup>3</sup>	<b>0.37</b>	<b>0.39</b>	<b>0.42</b>
Width	mm	2045	2207	2045
	in	<b>80.5</b>	<b>86.9</b>	<b>80.5</b>
Dump clearance at maximum lift/dump	mm	2298	2297	2355
	in	<b>90.5</b>	<b>90.4</b>	<b>92.7</b>
Reach at maximum lift/dump	mm	908	909	871
	in	<b>35.7</b>	<b>35.8</b>	<b>34.3</b>
Floor angle at maximum lift/dump	degrees	<b>-54.1</b>	<b>-54.1</b>	<b>-53.9</b>
Floor angle at maximum lift/rack back	degrees	<b>80.9</b>	<b>80.9</b>	<b>81.0</b>
Clearance at maximum lift/level bucket	mm	2953	2952	2968
	in	<b>116.3</b>	<b>116.2</b>	<b>116.8</b>
Hinge pin height at maximum lift	mm	3194	3193	3198
	in	<b>125.7</b>	<b>125.7</b>	<b>125.9</b>
Maximum overall height	mm	4098	4098	4045
	in	<b>161.3</b>	<b>161.3</b>	<b>159.2</b>
Reach at level lift arm/bucket	mm	1419	1419	1355
	in	<b>55.9</b>	<b>55.9</b>	<b>53.4</b>
Maximum floor angle at minimum lift	degrees	<b>24.6</b>	<b>24.6</b>	<b>24.8</b>
Dig depth with level bucket	mm	-92	-93	-80
	in	<b>-3.6</b>	<b>-3.7</b>	<b>-3.1</b>
Overall length with bucket on ground	mm	4002	4002	3944
	in	<b>157.6</b>	<b>157.6</b>	<b>155.3</b>
Front clearance circle radius (with bucket)	mm	2395	2429	2344
	in	<b>94.3</b>	<b>95.6</b>	<b>92.3</b>
Tipping load	kg	4099.4	4076.5	4408.7
	lb	<b>9038</b>	<b>8987</b>	<b>9719</b>
Breakout force — lift	kg	2547.3	2527.1	2727.6
	lb	<b>5616</b>	<b>5571</b>	<b>6013</b>
Breakout force — tilt	kg	2839.0	2826.8	3113.5
	lb	<b>6259</b>	<b>6232</b>	<b>6864</b>
Operating weight	kg	5673.7	5697.7	5508.3
	lb	<b>12,508</b>	<b>12,561</b>	<b>12,144</b>

Work Tool		Pallet Fork		
		910 mm (36")	1070 mm (42")	1220 mm (48")
<b>Tine Length</b>		<b>910 mm (36")</b>	<b>1070 mm (42")</b>	<b>1220 mm (48")</b>
<b>Carriage Assembly No.</b>		<b>353-1694</b>	<b>353-1696</b>	<b>353-1697</b>
Carriage overall width without step	mm	1160	1160	1160
	in	<b>45.7</b>	<b>45.7</b>	<b>45.7</b>
Carriage step additional width	mm	106	106	106
	in	<b>4.2</b>	<b>4.2</b>	<b>4.2</b>
Carriage height above blade top	mm	926	926	926
	in	<b>36.5</b>	<b>36.5</b>	<b>36.5</b>
Blade surface height at maximum height	mm	3063	3059	3054
	in	<b>120.6</b>	<b>120.4</b>	<b>120.3</b>
Shank front face reach at maximum height	mm	831	831	833
	in	<b>32.7</b>	<b>32.7</b>	<b>32.8</b>
Blade surface height at level lift arms	mm	1381	1377	1372
	in	<b>54.4</b>	<b>54.2</b>	<b>54.0</b>
Shank front face reach at level lift arms	mm	787	788	789
	in	<b>31.0</b>	<b>31.0</b>	<b>31.0</b>
Blade surface height at minimum lift	mm	14	11	8
	in	<b>0.6</b>	<b>0.4</b>	<b>0.3</b>
Shank front face reach at minimum lift	mm	403	403	404
	in	<b>15.9</b>	<b>15.9</b>	<b>15.9</b>
Overall length at minimum lift, level tine	mm	4289	4449	4600
	in	<b>168.9</b>	<b>175.2</b>	<b>181.1</b>
Tipping load	kg	3498.9	3324.6	3174.7
	lb	<b>7714</b>	<b>7329</b>	<b>6999</b>
Operating weight	kg	5419.0	5429.3	5438.9
	lb	<b>11,947</b>	<b>11,969</b>	<b>11,991</b>

<b>Bucket Type</b>		<b>General Purpose: Bolt-on Edge</b>	
		<b>1981 mm (78")</b>	<b>2134 mm (84")</b>
<b>Bucket Width</b>		<b>1981 mm (78")</b>	<b>2134 mm (84")</b>
<b>Ground Engaging Type</b>		<b>Bolt-on Edge</b>	<b>Bolt-on Edge</b>
<b>Bucket Assembly No.</b>		<b>279-5377</b>	<b>296-8192</b>
Rated bucket capacity	<b>m<sup>3</sup></b>	0.48	0.63
	<b>yd<sup>3</sup></b>	<b>0.63</b>	<b>0.82</b>
Struck capacity	<b>m<sup>3</sup></b>	0.32	0.59
	<b>yd<sup>3</sup></b>	<b>0.42</b>	<b>0.77</b>
Width	<b>mm</b>	2045	2198
	<b>in</b>	<b>80.5</b>	<b>86.5</b>
Dump clearance at maximum lift/dump	<b>mm</b>	2310	2233
	<b>in</b>	<b>91.0</b>	<b>87.9</b>
Reach at maximum lift/dump	<b>mm</b>	901	956
	<b>in</b>	<b>35.5</b>	<b>37.6</b>
Floor angle at maximum lift/dump	<b>degrees</b>	<b>-54.0</b>	<b>-54.0</b>
Floor angle at maximum lift/rack back	<b>degrees</b>	<b>81.0</b>	<b>81.0</b>
Clearance at maximum lift/level bucket	<b>mm</b>	2963	2957
	<b>in</b>	<b>116.7</b>	<b>116.4</b>
Hinge pin height at maximum lift	<b>mm</b>	3197	3196
	<b>in</b>	<b>125.9</b>	<b>125.8</b>
Maximum overall height	<b>mm</b>	4096	4187
	<b>in</b>	<b>161.3</b>	<b>164.8</b>
Reach at level lift arm/bucket	<b>mm</b>	1409	1503
	<b>in</b>	<b>55.5</b>	<b>59.2</b>
Maximum floor angle at minimum lift	<b>degrees</b>	<b>24.7</b>	<b>24.7</b>
Dig depth with level bucket	<b>mm</b>	-84	-89
	<b>in</b>	<b>-3.3</b>	<b>-3.5</b>
Overall length with bucket on ground	<b>mm</b>	3997	4089
	<b>in</b>	<b>157.3</b>	<b>161.0</b>
Front clearance circle radius (with bucket)	<b>mm</b>	2388	2498
	<b>in</b>	<b>94.0</b>	<b>98.4</b>
Tipping load	<b>kg</b>	4354.7	4224.4
	<b>lb</b>	<b>9600</b>	<b>9313</b>
Breakout force — lift	<b>kg</b>	2663.7	2558.7
	<b>lb</b>	<b>5872</b>	<b>5641</b>
Breakout force — tilt	<b>kg</b>	2908.3	2589.2
	<b>lb</b>	<b>6412</b>	<b>5708</b>
Operating weight	<b>kg</b>	5629.7	5666.6
	<b>lb</b>	<b>12,411</b>	<b>12,493</b>

Bucket Type		Multi-Purpose: Bolt-on Edge		Dirt: Bolt-on Edge
		1981 mm (78")	2134 mm (84")	1981 mm (78")
Bucket Width		Bolt-on Edge		Bolt-on Edge
Bucket Assembly No.		Bolt-on Edge		Bolt-on Edge
Bucket Assembly No.		279-5402	296-8057	268-4083
Rated bucket capacity	m <sup>3</sup>	0.40	0.43	0.44
	yd <sup>3</sup>	<b>0.52</b>	<b>0.56</b>	<b>0.58</b>
Struck capacity	m <sup>3</sup>	0.28	0.30	0.32
	yd <sup>3</sup>	<b>0.37</b>	<b>0.39</b>	<b>0.42</b>
Width	mm	2045	2207	2045
	in	<b>80.5</b>	<b>86.9</b>	<b>80.5</b>
Dump clearance at maximum lift/dump	mm	2298	2297	2355
	in	<b>90.5</b>	<b>90.4</b>	<b>92.7</b>
Reach at maximum lift/dump	mm	908	908	871
	in	<b>35.7</b>	<b>35.8</b>	<b>34.3</b>
Floor angle at maximum lift/dump	degrees	<b>-54.1</b>	<b>-54.1</b>	<b>-53.9</b>
Floor angle at maximum lift/rack back	degrees	<b>80.9</b>	<b>80.9</b>	<b>81.0</b>
Clearance at maximum lift/level bucket	mm	2954	2953	2968
	in	<b>116.3</b>	<b>116.2</b>	<b>116.9</b>
Hinge pin height at maximum lift	mm	3194	3193	3198
	in	<b>125.7</b>	<b>125.7</b>	<b>125.9</b>
Maximum overall height	mm	4098	4098	4045
	in	<b>161.4</b>	<b>161.3</b>	<b>159.2</b>
Reach at level lift arm/bucket	mm	1418	1419	1355
	in	<b>55.8</b>	<b>55.9</b>	<b>53.4</b>
Maximum floor angle at minimum lift	degrees	<b>24.6</b>	<b>24.6</b>	<b>24.8</b>
Dig depth with level bucket	mm	-92	-93	-80
	in	<b>-3.6</b>	<b>-3.7</b>	<b>-3.1</b>
Overall length with bucket on ground	mm	4002	4002	3944
	in	<b>157.6</b>	<b>157.6</b>	<b>155.3</b>
Front clearance circle radius (with bucket)	mm	2395	2429	2344
	in	<b>94.3</b>	<b>95.6</b>	<b>92.3</b>
Tipping load	kg	4179.3	4156.5	4491.5
	lb	<b>9214</b>	<b>9163</b>	<b>9902</b>
Breakout force — lift	kg	2542.1	2522.0	2722.4
	lb	<b>5604</b>	<b>5560</b>	<b>6002</b>
Breakout force — tilt	kg	2839.0	2826.8	3113.5
	lb	<b>6259</b>	<b>6232</b>	<b>6864</b>
Operating weight	kg	5776.0	5800.0	5610.6
	lb	<b>12,734</b>	<b>12,787</b>	<b>12,369</b>

Work Tool		Pallet Fork		
		910 mm (36")	1070 mm (42")	1220 mm (48")
<b>Tine Length</b>				
<b>Carriage Assembly No.</b>		<b>353-1694</b>	<b>353-1696</b>	<b>353-1697</b>
Carriage overall width without step	mm	1160	1160	1160
	in	<b>45.7</b>	<b>45.7</b>	<b>45.7</b>
Carriage step additional width	mm	106	106	106
	in	<b>4.2</b>	<b>4.2</b>	<b>4.2</b>
Carriage height above blade top	mm	926	926	926
	in	<b>36.5</b>	<b>36.5</b>	<b>36.5</b>
Blade surface height at maximum height	mm	3063	3059	3055
	in	<b>120.6</b>	<b>120.4</b>	<b>120.3</b>
Shank front face reach at maximum height	mm	831	831	833
	in	<b>32.7</b>	<b>32.7</b>	<b>32.8</b>
Blade surface height at level lift arms	mm	1371	1377	1372
	in	<b>54.0</b>	<b>54.2</b>	<b>54.0</b>
Shank front face reach at level lift arms	mm	787	788	789
	in	<b>31.0</b>	<b>31.0</b>	<b>31.0</b>
Blade surface height at minimum lift	mm	14	11	8
	in	<b>0.6</b>	<b>0.4</b>	<b>0.3</b>
Shank front face reach at minimum lift	mm	403	403	404
	in	<b>15.9</b>	<b>15.9</b>	<b>15.9</b>
Overall length at minimum lift, level tine	mm	4289	4449	4600
	in	<b>168.9</b>	<b>175.2</b>	<b>181.1</b>
Tipping load	kg	3563.5	3386.2	3233.7
	lb	<b>7856</b>	<b>7465</b>	<b>7129</b>
Operating weight	kg	5521.3	5531.6	5541.2
	lb	<b>12,172</b>	<b>12,195</b>	<b>12,216</b>

## Dimensions ● 239D/249D/259D

## Compact Track Loaders

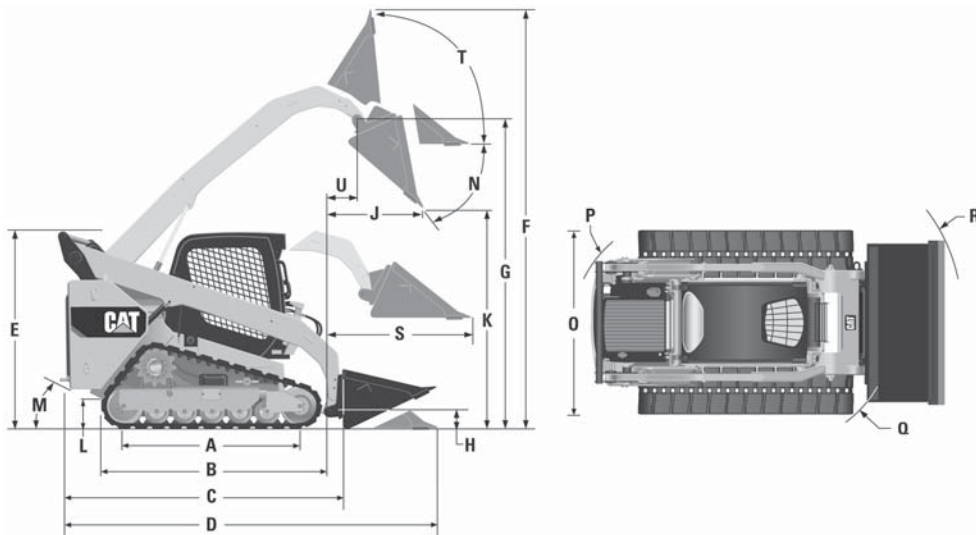

MODEL	239D		249D		259D	
Operating weight	3306 kg	<b>7289 lb</b>	3486 kg	<b>7685 lb</b>	4013 kg	<b>8846 lb</b>
Rated operating capacity at 35%	652 kg	<b>1437 lb</b>	729 kg	<b>1608 lb</b>	921 kg	<b>2030 lb</b>
Rated operating capacity at 50%	931 kg	<b>2053 lb</b>	1044 kg	<b>2300 lb</b>	1315 kg	<b>2900 lb</b>
Tipping load	1863 kg	<b>4107 lb</b>	2087 kg	<b>4600 lb</b>	2631 kg	<b>5800 lb</b>
Breakout force, tilt cylinder	1801 kg	<b>3969 lb</b>	1798 kg	<b>3963 lb</b>	2284 kg	<b>5035 lb</b>
Ground pressure	36.6 kPa	<b>5.3 psi</b>	38.6 kPa	<b>5.6 psi</b>	41.1 kPa	<b>6.0 psi</b>
A Length of track on ground	1384 mm	<b>54.5"</b>	1384 mm	<b>54.5"</b>	1499 mm	<b>59.0"</b>
B Overall length of track	1808 mm	<b>71.2"</b>	1808 mm	<b>71.2"</b>	1999 mm	<b>78.7"</b>
C Length without bucket	2522 mm	<b>99.3"</b>	2523 mm	<b>99.3"</b>	2767 mm	<b>108.9"</b>
D Length with bucket on ground	3234 mm	<b>127.3"</b>	3233 mm	<b>127.3"</b>	3486 mm	<b>137.3"</b>
E Height to top of cab	2034 mm	<b>80.1"</b>	2039 mm	<b>80.3"</b>	2111 mm	<b>83.1"</b>
F Maximum overall height	3645 mm	<b>143.5"</b>	3831 mm	<b>150.8"</b>	3915 mm	<b>154.1"</b>
G Bucket pin height at maximum lift	2825 mm	<b>111.2"</b>	3002 mm	<b>118.2"</b>	3075 mm	<b>121.0"</b>
H Bucket pin height at carry position	218 mm	<b>8.6"</b>	219 mm	<b>8.6"</b>	198 mm	<b>7.8"</b>
J Reach at maximum lift and dump	563 mm	<b>22.2"</b>	727 mm	<b>28.6"</b>	608 mm	<b>23.9"</b>
K Clearance at maximum lift and dump	2057 mm	<b>81.0"</b>	2253 mm	<b>88.7"</b>	2283 mm	<b>89.9"</b>
L Ground clearance	195 mm	<b>7.7"</b>	194 mm	<b>7.6"</b>	226 mm	<b>8.9"</b>
M Departure angle		<b>35°</b>		<b>35°</b>		<b>35°</b>
N Maximum dump angle		<b>50°</b>		<b>48°</b>		<b>52°</b>
O Vehicle width	1676 mm	<b>66.0"</b>	1676 mm	<b>66.0"</b>	1676 mm	<b>66.0"</b>
P Turning radius from center — machine rear	1458 mm	<b>57.4"</b>	1458 mm	<b>57.4"</b>	1561 mm	<b>61.5"</b>
Q Turning radius from center — coupler	1159 mm	<b>45.6"</b>	1160 mm	<b>45.7"</b>	1392 mm	<b>54.8"</b>
R Turning radius from center — bucket	2069 mm	<b>81.5"</b>	2060 mm	<b>81.1"</b>	2184 mm	<b>86.0"</b>
S Maximum reach with arms parallel to ground	1356 mm	<b>53.4"</b>	1317 mm	<b>51.8"</b>	1305 mm	<b>51.4"</b>
T Rack back angle at maximum height		<b>86°</b>		<b>88°</b>		<b>87°</b>
U Bucket pin reach at maximum lift	173 mm	<b>6.8"</b>	311 mm	<b>12.2"</b>	238 mm	<b>9.4"</b>

**NOTE:** 239D and 249D based on 75 kg (165 lb) operator, all fluids, one speed, OROPS, dual flange front idler/single flange rear idler, standard flow hydraulics, mechanical suspension seat, no optional counterweights and manual quick coupler (unless otherwise noted), 1676 mm (66") dirt bucket and 320 mm (12.6") track.

**NOTE:** 259D based on 75 kg (165 lb) operator, all fluids, two speed, OROPS, dual flange front idler/single flange rear idler, standard flow hydraulics, mechanical suspension seat, no optional counterweights and manual quick coupler (unless otherwise noted), 1676 mm (66") dirt bucket and 320 mm (12.6") track.



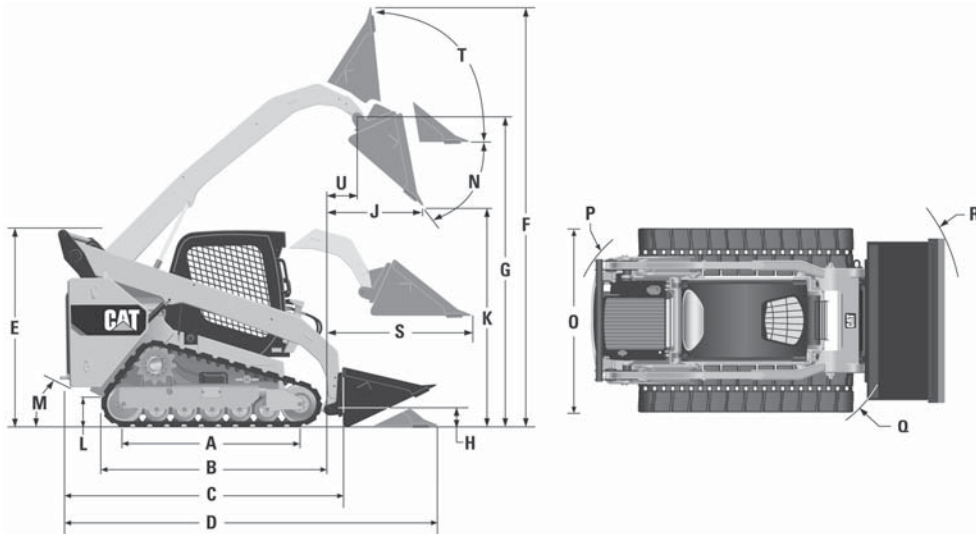

MODEL	279D		289D		299D2	
Operating weight	4487 kg	<b>9893 lb</b>	4778 kg	<b>10,533 lb</b>	5114 kg	<b>11,275 lb</b>
Rated operating capacity at 35%	932 kg	<b>2055 lb</b>	1207 kg	<b>2660 lb</b>	1451 kg	<b>3200 lb</b>
Rated operating capacity at 50%	1331 kg	<b>2935 lb</b>	1724 kg	<b>3800 lb</b>	2087 kg	<b>4600 lb</b>
Tipping load	2663 kg	<b>5870 lb</b>	3447 kg	<b>7600 lb</b>	4173 kg	<b>9200 lb</b>
Breakout force, tilt cylinder	3304 kg	<b>7285 lb</b>	3307 kg	<b>7291 lb</b>	3298 kg	<b>7270 lb</b>
Ground pressure	33.9 kPa	<b>4.9 psi</b>	36.1 kPa	<b>5.2 psi</b>	35.6 kPa	<b>5.2 psi</b>
A Length of track on ground	1630 mm	<b>64.2"</b>	1630 mm	<b>64.2"</b>	1767 mm	<b>69.6"</b>
B Overall length of track	2129 mm	<b>83.8"</b>	2129 mm	<b>83.8"</b>	2270 mm	<b>89.4"</b>
C Length without bucket	2995 mm	<b>117.9"</b>	2995 mm	<b>117.9"</b>	3189 mm	<b>125.5"</b>
D Length with bucket on ground	3714 mm	<b>146.2"</b>	3714 mm	<b>146.2"</b>	3931 mm	<b>154.7"</b>
E Height to top of cab	2113 mm	<b>83.2"</b>	2113 mm	<b>83.2"</b>	2125 mm	<b>83.6"</b>
F Maximum overall height	4051 mm	<b>159.5"</b>	4015 mm	<b>158.1"</b>	4032 mm	<b>158.7"</b>
G Bucket pin height at maximum lift	3173 mm	<b>124.9"</b>	3178 mm	<b>125.1"</b>	3208 mm	<b>126.3"</b>
H Bucket pin height at carry position	198 mm	<b>7.8"</b>	190 mm	<b>7.5"</b>	180 mm	<b>7.1"</b>
J Reach at maximum lift and dump	575 mm	<b>22.6"</b>	761 mm	<b>30.0"</b>	852 mm	<b>33.6"</b>
K Clearance at maximum lift and dump	2485 mm	<b>97.8"</b>	2387 mm	<b>94.0"</b>	2399 mm	<b>94.5"</b>
L Ground clearance	226 mm	<b>8.9"</b>	226 mm	<b>8.9"</b>	245 mm	<b>9.6"</b>
M Departure angle		<b>32°</b>		<b>33°</b>		<b>33°</b>
N Maximum dump angle		<b>39°</b>		<b>51°</b>		<b>54°</b>
O Vehicle width	1931 mm	<b>76.0"</b>	1931 mm	<b>76.0"</b>	1931 mm	<b>76.0"</b>
P Turning radius from center — machine rear	1796 mm	<b>70.7"</b>	1796 mm	<b>70.7"</b>	1881 mm	<b>74.0"</b>
Q Turning radius from center — coupler	1410 mm	<b>55.5"</b>	1410 mm	<b>55.5"</b>	1476 mm	<b>58.1"</b>
R Turning radius from center — bucket	2256 mm	<b>88.8"</b>	2256 mm	<b>88.8"</b>	2314 mm	<b>91.1"</b>
S Maximum reach with arms parallel to ground	1373 mm	<b>54.0"</b>	1270 mm	<b>50.0"</b>	1319 mm	<b>51.9"</b>
T Rack back angle at maximum height		<b>84°</b>		<b>84°</b>		<b>81°</b>
U Bucket pin reach at maximum lift		—	369 mm	<b>14.5"</b>	493 mm	<b>19.4"</b>

**NOTE:** 279D and 289D based on 75 kg (165 lb) operator, all fluids, two speed, OROPS, dual flange front idler/single flange rear idler, standard flow hydraulics, mechanical suspension seat, no optional counterweights and manual quick coupler (unless otherwise noted), 400 mm (15.7") track and 1981 mm (78") dirt bucket.

**NOTE:** 299D2 based on 75 kg (165 lb) operator, all fluids, two speed, 1981 mm (78") dirt bucket, 400 mm (15.7") tracks, and manual quick coupler (unless otherwise noted). 299D2 based on dual flange front idler/single flange rear idler, C2 enclosed cab with heat, glass door, standard flow hydraulics, mechanical suspension seat, and no optional counterweights.

Dimensions  
 ● 299D2 XHP/299D2 (Steel Track)/  
 299D2 XHP (Steel Track)

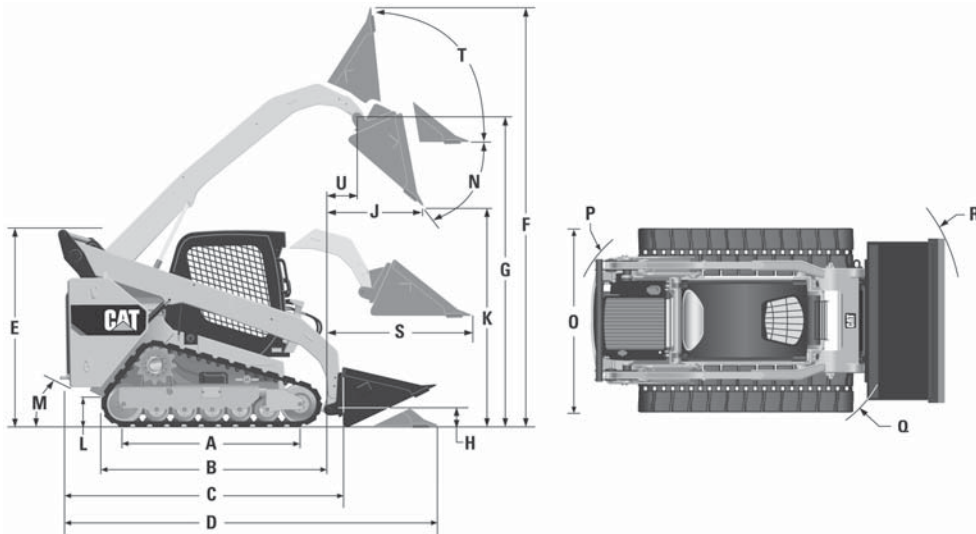

MODEL	299D2 XHP		299D2 (Steel Track)		299D2 XHP (Steel Track)	
Operating weight	5265 kg	<b>11,608 lb</b>	5468 kg	<b>12,055 lb</b>	5571 kg	<b>12,281 lb</b>
Rated operating capacity at 35%	1500 kg	<b>3308 lb</b>	1579 kg	<b>3481 lb</b>	1608 kg	<b>3546 lb</b>
Rated operating capacity at 50%	2143 kg	<b>4725 lb</b>	2255 kg	<b>4972 lb</b>	2298 kg	<b>5065 lb</b>
Tipping load	4286 kg	<b>9450 lb</b>	4511 kg	<b>9945 lb</b>	4595 kg	<b>10,131 lb</b>
Breakout force, tilt cylinder	3298 kg	<b>7270 lb</b>	3298 kg	<b>7270 lb</b>	3298 kg	<b>7270 lb</b>
Ground pressure	36.7 kPa	<b>5.3 psi</b>	38.1 kPa	<b>5.5 psi</b>	38.8 kPa	<b>5.6 psi</b>
A Length of track on ground	1767 mm	<b>69.6"</b>	1767 mm	<b>69.6"</b>	1767 mm	<b>69.6"</b>
B Overall length of track	2270 mm	<b>89.4"</b>	2270 mm	<b>89.4"</b>	2270 mm	<b>89.4"</b>
C Length without bucket	3189 mm	<b>125.5"</b>	3189 mm	<b>125.5"</b>	3189 mm	<b>125.5"</b>
D Length with bucket on ground	3931 mm	<b>154.7"</b>	3931 mm	<b>154.7"</b>	3931 mm	<b>154.7"</b>
E Height to top of cab	2125 mm	<b>83.6"</b>	2125 mm	<b>83.6"</b>	2125 mm	<b>83.6"</b>
F Maximum overall height	4032 mm	<b>158.7"</b>	4032 mm	<b>158.7"</b>	4032 mm	<b>158.7"</b>
G Bucket pin height at maximum lift	3208 mm	<b>126.3"</b>	3208 mm	<b>126.3"</b>	3208 mm	<b>126.3"</b>
H Bucket pin height at carry position	180 mm	<b>7.1"</b>	180 mm	<b>7.1"</b>	180 mm	<b>7.1"</b>
J Reach at maximum lift and dump	852 mm	<b>33.6"</b>	852 mm	<b>33.6"</b>	852 mm	<b>33.6"</b>
K Clearance at maximum lift and dump	2399 mm	<b>94.5"</b>	2399 mm	<b>94.5"</b>	2399 mm	<b>94.5"</b>
L Ground clearance	245 mm	<b>9.6"</b>	245 mm	<b>9.6"</b>	245 mm	<b>9.6"</b>
M Departure angle		<b>33°</b>		<b>33°</b>		<b>33°</b>
N Maximum dump angle		<b>54°</b>		<b>54°</b>		<b>54°</b>
O Vehicle width	1931 mm	<b>76.0"</b>	1931 mm	<b>76.0"</b>	1931 mm	<b>76.0"</b>
P Turning radius from center — machine rear	1881 mm	<b>74.0"</b>	1881 mm	<b>74.0"</b>	1881 mm	<b>74.0"</b>
Q Turning radius from center — coupler	1476 mm	<b>58.1"</b>	1476 mm	<b>58.1"</b>	1476 mm	<b>58.1"</b>
R Turning radius from center — bucket	2314 mm	<b>91.1"</b>	2314 mm	<b>91.1"</b>	2314 mm	<b>91.1"</b>
S Maximum reach with arms parallel to ground	1319 mm	<b>51.9"</b>	1319 mm	<b>51.9"</b>	1319 mm	<b>51.9"</b>
T Rack back angle at maximum height		<b>81°</b>		<b>81°</b>		<b>81°</b>
U Bucket pin reach at maximum lift	493 mm	<b>19.4"</b>	493 mm	<b>19.4"</b>	493 mm	<b>19.4"</b>

NOTE: Based on 75 kg (165 lb) operator, all fluids, two speed, 1981 mm (78") dirt bucket, 400 mm (15.7") tracks, and manual quick coupler (unless otherwise noted). 299D2 based on dual flange front idler/single flange rear idler, C2 enclosed cab with heat, glass door, standard flow hydraulics, mechanical suspension seat, and no optional counterweights. 299D2 XHP based on triple flange front/rear idlers, ride control, C3 enclosed cab A/C and glass door, side windows, and air ride seat.

**CAT WORK TOOL COMPATIBILITY**

	239D	249D	259D	279D	289D	299D2	299D2 XHP
<b>General Purpose Buckets</b>							
1524 mm (60")	C	C	C	C	C	C	C
1676 mm (66")	C	C	C	C	C	C	C
1829 mm (72")	C	C	C	C	C	C	C
1981 mm (78")	C	C	C	C	C	C	C
<b>High Capacity Bucket (GP)</b>							
2134 mm (84")	C	C	C	C	C	C	C
<b>Dirt Buckets</b>							
1372 mm (54")	C	C	C	C	C	C	C
1524 mm (60")	C	C	C	C	C	C	C
1676 mm (66")	C	C	C	C	C	C	C
1829 mm (72")	C	C	C	C	C	C	C
1981 mm (78")	C	C	C	C	C	C	C
<b>Utility Buckets</b>							
1524 mm (60")	C	C	C	C	C	C	C
1676 mm (66")	C	C	C	C	C	C	C
1829 mm (72")	C	C	C	C	C	C	C
<b>Light Material Buckets</b>							
1829 mm (72")	C	C	C	C	C	C	C
1981 mm (78")	C	C	C	C	C	C	C
2134 mm (84")	C	C	C	C	C	C	C
2438 mm (96")	C	C	C	C	C	C	C
<b>Multi-Purpose Buckets</b>							
1524 mm (60")	C	C	C	C	C	C	C
1676 mm (66")	C	C	C	C	C	C	C
1829 mm (72")	C	C	C	C	C	C	C
1981 mm (78")	C	C	C	C	C	C	C
2134 mm (84")	C	C	C	C	C	C	C
<b>Industrial Grapple Buckets</b>							
1524 mm (60")	C	C	C	C	C	C	C
1676 mm (66")	C	C	C	C	C	C	C
1829 mm (72")	C	C	C	C	C	C	C
1981 mm (78")	C	C	C	C	C	C	C
<b>Industrial Grapple Forks</b>							
1676 mm (66")	C	C	C	C	C	C	C
1829 mm (72")	C	C	C	C	C	C	C
<b>Industrial Grapple Rakes</b>							
1829 mm (72")	C	C	C	C	C	C	C
2134 mm (84")	C	C	C	C	C	C	C
<b>Utility Grapple Buckets</b>							
1676 mm (66")	C	C	C	C	C	C	C
1829 mm (72")	C	C	C	C	C	C	C

C – Compatible.

**CAT WORK TOOL COMPATIBILITY**

	239D	249D	259D	279D	289D	299D2	299D2 XHP
<b>Carriage</b>	C	C	C	C	C	C	C
<b>Pallet Forks</b>							
910 mm (36") Tines	C	C	C	C	C	C	C
1070 mm (42") Tines	C	C	C	C	C	C	C
1220 mm (48") Tines	C	C	C	C	C	C	C
<b>Utility Grapple Forks</b>							
1676 mm (66")	C	C	C	C	C	C	C
1829 mm (72")	C	C	C	C	C	C	C
<b>Utility Forks</b>							
1676 mm (66")	C	C	C	C	C	C	C
1829 mm (72")	C	C	C	C	C	C	C
<b>Angle Blades</b>							
1829 mm (72")	C	C	C	C	C	C	C
2134 mm (84")	C	C	C	C	C	C	C
<b>Dozer Blades</b>							
2000 mm (79")	C	C	C	C	C	C	C
2337 mm (92")	C	C	C	C	C	C	C
<b>A14B Auger</b>	C	C	C	C	C	C	C
<b>A19B Auger</b>	C	C	C	C	C	C	C
<b>A26B Auger</b>	C	C	C	C	C	C	C
<b>BH150 Backhoe</b>	C	C	C	C	C	C	C
<b>BH160 Backhoe</b>	X	X	X	C	C	C	C,R
<b>BR160 Brushcutter</b>	C	C	X	X	X	X	X
<b>BR166 Brushcutter</b>	X	X	C	C	C	C	C
<b>BR172 Brushcutter</b>	X	X	C	C	C	C	C
<b>BR272 Brushcutter</b>	C	C	X	X	X	X	X
<b>BR378 Brushcutter</b>	X	X	X	C	C	C	C
<b>BP115C Pickup Broom</b>	C	C*	C	C	C	C	C
<b>BP118C Pickup Broom</b>	C*	C*	C*	C	C	C	C
<b>BA118C Angle Broom</b>	C	C	C	C	C	C	C
<b>BU115 Utility Broom</b>	C	C*	C	C	C	C	C
<b>BU118 Utility Broom</b>	C*	C*	C*	C	C	C	C
<b>PC104B Cold Planer</b>	C	C	C	C	C	C	C
<b>PC205B Cold Planer</b>	C	C	C	C	C	C	C
<b>PC305B Cold Planer</b>	C	C	C	C	C	C	C
<b>PC306B Cold Planer</b>	C	C	C	C	C	C	C
<b>PC306B XD Cold Planer</b>	X	X	X	C	C	C	C
<b>PC310B Cold Planer</b>	X	X	X	C	C	C	C
<b>PC310B XD Cold Planer</b>	X	X	X	X	C*,R	C*,R	C*,R
<b>PC408B Cold Planer</b>	X	X	X	X	X	X	C
<b>PC412B Cold Planer</b>	X	X	X	X	X	X	C

C – Compatible.

C\* – Compatible but Lift Restrictions Apply.

R – Machine must have limited options installed to avoid exceeding the maximum total machine rated capacity. Refer to the Operation and Maintenance Manual for the specific Work Tool for details.

X – Not Compatible.

**CAT WORK TOOL COMPATIBILITY**

	239D	249D	259D	279D	289D	299D2	299D2 XHP
H55E S Hammer	C,D	C,D	C,D	C,D	C,D	C,D	C,D
H65E S Hammer	C,D	C,D	C,D	C,D	C,D	C,D	C,D
LR15B Landscape Rake	C*	C*	C*	C	C	C	C
LR18B Landscape Rake	C*	C*	C*	C	C	C	C
LT13B Landscape Tiller	C	C	C	C	C	C	C
LT18B Landscape Tiller	X	C	C	C	C	C	C
Material Handling Arm	C	C	C	C	C	C	C
HM315B Mulcher	X	X	X	C	C	C	C
HM415B Mulcher	X	X	X	X	X	X	C
PR172 Power Box Rake	C	C	C	C	C	C	C
PR184 Power Box Rake	C	C	C	C	C	C	C
PR190 Power Box Rake	C	C	C	C	C	C	C
S305 Shear	C,D	C,D	C,D	C,D	C,D	C,D	C,D
Sectional Snow Push 2440 mm (8 ft)	C	C	C	C	C	C	C
Sectional Snow Push 3050 mm (10 ft)	C	C	C	C	C	C	C
Sectional Snow Push 3660 mm (12 ft)	X	X	X	C	C	C	C
Sectional Snow Push 4270 mm (15 ft)	X	X	X	X	X	C	C
SR117 Snowblower	C	C	X	X	X	X	X
SR118 Snowblower	X	X	C	C	C	C	C
SR121 Snowblower	X	X	C	C	C	C	C
SR318 Snowblower	C	C	C	C	C	C	C
SR321 Snowblower	C	C	C	C	C	C	C
SG16B Stump Grinder	C	C	C	C	C	C	C
SG18B Stump Grinder	C	C	C	C	C	C	C
T6B Trencher	C	C	C	C	C	C	C
T9B Trencher	C	C	C	C	C	C	C
T15B Trencher	C	C	C	C	C	C	C
CV16B Vibratory Compactor	C*	C*	C*	C	C	C	C
CV18B Vibratory Compactor	X	X	X	C	C	C	C
SW345B Wheel Saw – 80 mm (3")	C^	C^	C^	C	C	C	C
SW345B Wheel Saw – 130 mm (5")	C^	C^	C*	C	C	C	C
SW360B Wheel Saw – 80 mm (3")	X	X	X	C^	C^	C	C,R
SW360B Wheel Saw – 100 mm (4")	X	X	X	C^	C^	C	C,R
SW360B Wheel Saw – 130 mm (5")	X	X	X	C^	C^	C	C,R
SW360B Wheel Saw – 150 mm (6")	X	X	X	C^	C^	C	C,R
SW360B Wheel Saw – 200 mm (8")	X	X	X	C^	C^	C	C,R
SW460B Wheel Saw – 80 mm (3")	X	X	X	X	X	X	C,R
SW460B Wheel Saw – 150 mm (6")	X	X	X	X	X	X	C,R
SW460B Wheel Saw – 200 mm (8")	X	X	X	X	X	X	C,R
SW380B Wheel Saw – 250 mm (10")	X	X	X	C^	C^	C	C,R
SW480B Wheel Saw – 250 mm (10")	X	X	X	X	X	X	C,R

C – Compatible.

C\* – Compatible but Lift Restrictions Apply.

C^ – Compatible but Lift Restrictions Apply and Maximum Machine Counterweights Required.

R – Machine must have limited options installed to avoid exceeding the maximum total machine rated capacity. Refer to the Operation and Maintenance Manual for the specific Work Tool for details.

D – European Union Restrictions Apply; Refer to Operation Maintenance Manual, "Safety Section: Worktools: Demolition."

X – Not Compatible.

**Features:**

- **Cat XT™-3 hose and O-ring face seals** are used throughout for superior leak-free performance.
- **Both standard and tree bits are available in a variety of sizes** for a wide range of projects.
- **Standard bit teeth and pilot points** are produced from hardened steel. Optional hardfaced and carbide inserted teeth are also available.
- **Optional bit extension is available** in 305 mm (12") length.
- **Hex-to-round shaft adapter is available** to accommodate existing round auger bit mountings.
- **A14B and A19B** are compatible with both mini hydraulic excavators and skid steer loaders.

**A14B Auger**

- **Direct drive system** features a variable speed, bidirectional, “Gerotor” style hydraulic motor that generates optimal speed and output torque for light to moderate duty work.

**A19B Auger**

- **Single reduction planetary drive system** transfers power from the drive motor to the drive shaft, reducing motor speed and increasing torque.
- **Drive motor shaft** is splined and couples directly to the planetary gearbox.

**A26B Auger**

- **Double reduction planetary drive system** transfers power from the drive motor to the drive shaft, reducing motor speed and increasing torque.
- **Drive motor shaft** is splined and couples directly to the planetary gearbox.

**Market Opportunities**

- **Agriculture** — Augers are an effective work tool around the farm to drill holes for fence posts, pole barn supports and footers for outbuildings.
- **Building/General Construction** — Augers are an essential work tool on many construction sites to drill holes for deck posts and footings, signs and fencing.

- **Landscaping/Landscape Maintenance** — Augers with special tree bits are ideal for preparing holes for tree planting. They are also ideal for school, park, golf course and recreational maintenance departments to drill holes for playground supports, trees and shrubs, fence posts, and signs.
- **Governmental/Municipalities** — Augers with multiple bit sizes are popular work tools to do a wide spectrum of jobs, including digging holes for traffic signs, poles, posts and trees.
- **Rental** — Augers are one of the highest opportunity rental work tool after buckets.
- **Specialty Trades/Utility** — Augers are ideal for electrical, fencing and plumbing contractors when installing lighting, fence posts and gas/water mains.

Augers are typically not a full time work tool, however they are a highly utilized option for specialized applications. They are often used in conjunction with a bucket, set of pallet forks and/or a trencher.

**Auger Bits**

Auger bits are available in standard duty, industrial duty, standard rock drill head and tree bit configurations with standard hardened, reversible teeth and cast/hardened pilot point. Optional hard-faced and carbide inserted teeth and pilot points are available for aggressive boring conditions. Standard bits are available in diameters ranging from 6"–36"; industrial bits and standard duty rock drill head bits are available in 6"–24" diameters and tree bits are available in 24" and 36" diameters. Typical digging depth is 48", however for deeper holes, optional 12", 24", 3' and 6' extensions are available. A special HEX to round adapter is also available for customers who use existing round shaft auger bits.

**Machine Compatibility**

Auger Model	Machine Models
A14B	216B3, 226B3, 226D, 232D, 236D, 239D, 242D, 246D, 249D, 257D, 259D, 262D, 272D2, 272D2 XHP, 277D, 279D, 287D, 289D, 297D2, 297D2 XHP, 299D2, 299D2 XHP
A19B	216B3, 226B3, 226D, 232D, 236D, 239D, 242D, 246D, 249D, 257D, 259D, 262D, 272D2, 272D2 XHP, 277D, 279D, 287D, 289D, 297D2, 297D2 XHP, 299D2, 299D2 XHP
A26B*	226B3, 226D, 232D, 236D, 239D, 242D, 246D, 249D, 257D, 259D, 262D, 272D2, 272D2 XHP, 277D, 279D, 287D, 289D, 297D2, 297D2 XHP, 299D2, 299D2 XHP

\*Requires high flow or high flow XPS option on machine.

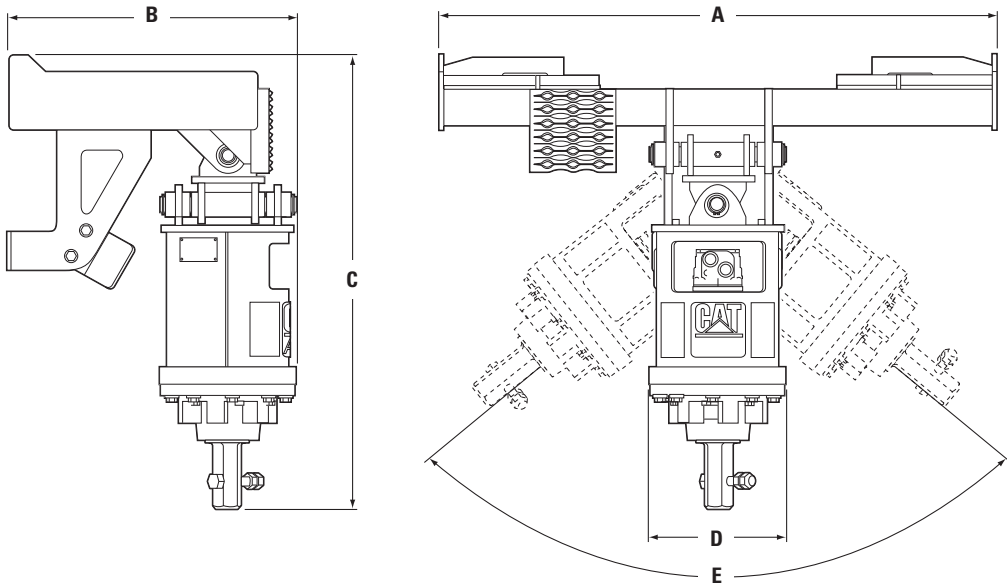

MODEL	A14B		A19B		A26B	
A Overall width with bracket	1152 mm	45"	1152 mm	45"	1152 mm	45"
B Overall length with bracket	593 mm	23"	593 mm	23"	599 mm	24"
C Overall drive unit height	1020 mm	40"	940 mm	37"	978 mm	39"
D Housing diameter	252 mm	10"	252 mm	10"	252 mm	10"
E Swing range	102°		102°		102°	
Drive unit weight with hydraulic lines without bit	84 kg	185 lb	79 kg	174 lb	91 kg	201 lb
Mounting frame weight with clevis	87 kg	192 lb	87 kg	192 lb	91 kg	201 lb
Total weight without bit	171 kg	317 lb	166 kg	366 lb	182 kg	402 lb
Drive method	<b>Gerotor Motor – Direct</b>		<b>Gerotor Motor – Single Planetary Reduction</b>		<b>Gear Motor – Double Planetary Reduction</b>	
Optimal hydraulic flow range	42-86 L/min	11-23 gpm	42-86 L/min	11-23 gpm	95-125 L/min	25-34 gpm
Optimal hydraulic pressure range	145-235 bar	2100-3400 psi	145-235 bar	2100-3400 psi	207-290 bar	3002-4206 psi
Effective displacement	629.1 cm <sup>3</sup> /rev	38.39 in <sup>3</sup> /rev	250 cm <sup>3</sup> /rev	15.26 in <sup>3</sup> /rev	43.77 cm <sup>3</sup> /rev	2.685 in <sup>3</sup> /rev
Drive shaft torque @ maximum pressure*	2304 N·m	1700 lb·ft	4122 N·m	3040 lb·ft	6826 N·m	5034 lb·ft
Bit speed (drive shaft) @ maximum flow	127 RPM		71 RPM		81 RPM	
HEX output shaft size	51 mm	2"	51 mm	2"	51 mm	2"
Auger bit retention method	<b>Cross bolts/nuts</b>		<b>Cross bolts/nuts</b>		<b>Cross bolts/nuts</b>	
Hydraulic hose	<b>Cat XT-3 ES</b>		<b>Cat XT-3 ES</b>		<b>Cat XT-6 ES</b>	

\*Theoretical values calculated at 100% efficiency.

### A14B Auger

Theoretical Bit Speed			Theoretical Digging Torque			
L/min	gpm	RPM	bar	psi	N-m	lb-ft
42	11	54	145	2100	1764	1300
45	12	59	152	2200	1848	1362
49	13	64	159	2300	1932	1424
53	14	69	166	2400	2016	1486
57	15	74	172	2500	2100	1548
61	16	79	179	2600	2184	1610
64	17	84	186	2700	2268	1672
68	18	89	193	2800	2352	1734
72	19	94	200	2900	2436	1795
76	20	99	207	3000	2520	1857
80	21	104	214	3100	2604	1919
83	22	109	221	3200	2688	1981
87	23	114	228	3300	2772	2043

### A19B Auger

Theoretical Bit Speed			Theoretical Digging Torque			
L/min	gpm	RPM	bar	psi	N-m	lb-ft
42	11	38	145	2100	2535	1868
45	12	41	152	2200	2655	1956
49	13	45	159	2300	2776	2045
53	14	48	166	2400	2897	2134
57	15	52	172	2500	3017	2223
61	16	55	179	2600	3138	2312
64	17	59	186	2700	3259	2401
68	18	62	193	2800	3379	2490
72	19	65	200	2900	3500	2579
76	20	69	207	3000	3621	2668
80	21	72	214	3100	3741	2757
83	22	76	221	3200	3862	2846
87	23	79	228	3300	3983	2935

### A26B Auger

Theoretical Bit Speed			Theoretical Digging Torque			
L/min	gpm	RPM	bar	psi	N-m	lb-ft
95	25	61	207	3000	4719	3492
99	26	64	214	3100	4880	3611
102	27	66	220	3200	5034	3725
106	28	69	227	3300	5191	3841
110	29	71	234	3400	5348	3958
114	30	74	241	3500	5506	4074
118	31	76	248	3600	5663	4191
121	32	79	255	3700	5820	4307
125	33	81	262	3800	5977	4423
129	34	84	269	3900	6135	4540
133	35	86	276	4000	6292	4656
136	36	88	282	4100	6449	4772
140	37	91	289	4200	6607	4889
144	38	93	296	4300	6764	5005
148	39	96	303	4400	6921	5122
152	40	98	310	4500	7079	5238



**Features:**

- **High-strength blades** deliver high cutting action and durability, and also mulch overgrowth.
- **Fully balanced blade carriers** prevent unnecessary vibration.
- **High-strength frame with reinforced corner gussets** provide strength in critical areas.
- **Long life motors** deliver years of high-speed blade performance.
- **Machined and heat treated gears** in sealed gearbox provide reliable, durable transfer of torque from motor to blade carrier.
- **Tapered blade carrier** allows cutter to ride up over stumps and rocks.
- **Galvanized coil chains** provide debris guarding in the front and rear areas to restrict flying debris and material.
- **Heavy-duty skids** allow easy movement of the brush-cutter through uneven terrain while maintaining stability of the work tool and machine.
- **Motor protection guard shields** motor and gear box from debris. Removing a set of bolts allows this hinged guard to be moved away for easy access to motor and gear box.
- **Cat XT-3 hose, couplings and O-ring face seals** provide superior, leak-free performance and reliability. All hoses are wrapped with nylon woven cordura sleeving for added operator protection. Hydraulic quick disconnects enable fast tool changes.
- **Quick coupler** with rugged, opposing edge design holds the work tool securely and allows the operator to quickly change from one high performance Cat Work Tool to another.

**Cat Brushcutters** are used for clearing overgrowth from highway medians, utility easements and for initial land clearing for housing, parks and recreational areas.

**Machine Compatibility**

<b>Brushcutter Model</b>	<b>Machine Models</b>
<b>BR160</b>	216B3, 226B3, 226D
<b>BR166#</b>	216B3, 226B3, 226D, 232D, 236D, 239D, 242D, 246D, 249D, 257D, 259D, 262D, 272D2, 272D2 XHP, 277D, 279D, 287D, 289D, 297D2, 297D2 XHP, 299D2, 299D2 XHP
<b>BR172#</b>	216B3, 226B3, 226D, 232D, 236D, 239D, 242D, 246D, 249D, 257D, 259D, 262D, 272D2, 272D2 XHP, 277D, 279D, 287D, 289D, 297D2, 297D2 XHP, 299D2, 299D2 XHP
<b>BR272*</b>	226B3, 226D
<b>BR378*#</b>	246D, 262D, 272D2, 272D2 XHP, 277D, 279D, 287D, 289D, 297D2, 297D2 XHP, 299D2, 299D2 XHP

\*Requires high flow or high flow XPS option on machine. Operates in high flow XPS on XHP machine.

#Requires a conversion kit for D Series machines.

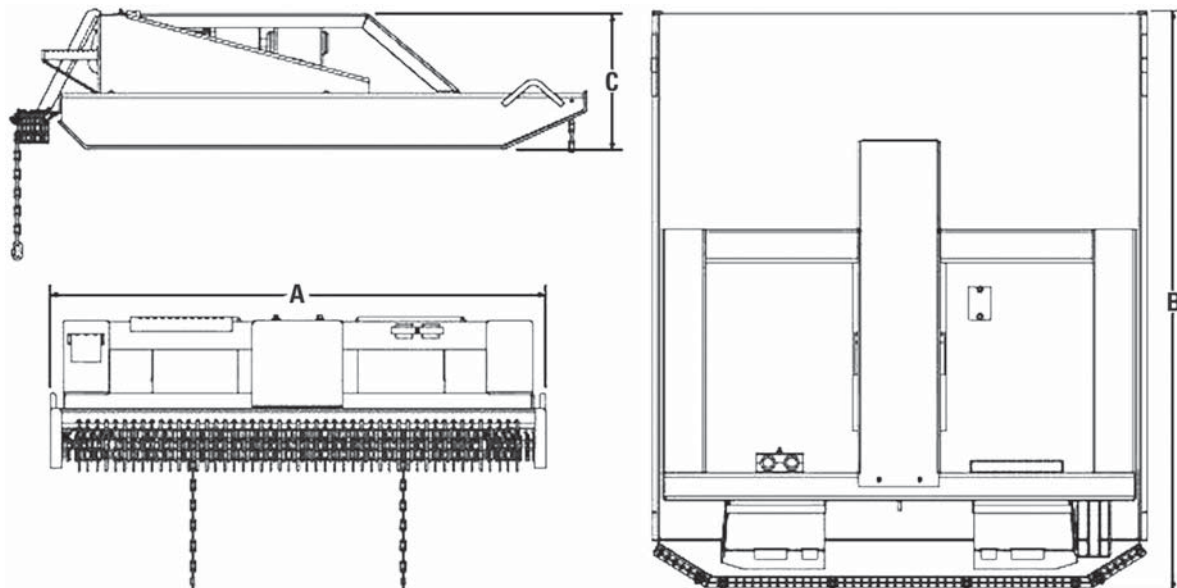

MODEL	BR160		BR166		BR172	
A Overall width	1575 mm	62"	1727 mm	68"	1880 mm	74"
B Overall length	1854 mm	73"	2007 mm	79"	2159 mm	85"
C Overall height	533 mm	21"	533 mm	21"	518 mm	20"
Cutting width	1524 mm	60"	1676 mm	66"	1829 mm	72"
Maximum cutting diameter	76 mm	3"	76 mm	3"	76 mm	3"
Unit weight	431 kg	950 lb	476 kg	1050 lb	499 kg	1100 lb
Optimal hydraulic flow range	57-65 L/min	15-17 gpm	57-80 L/min	15-21 gpm	57-80 L/min	15-21 gpm
Optimal hydraulic pressure range	150-230 bar	2176-3340 psi	150-230 bar	2176-3340 psi	150-230 bar	2176-3340 psi
Tip speed range (depends on flow)	3987-5596 m/min	13,080-18,360 ft/min	3130-4395 m/min	10,270-14,420 ft/min	3417-4795 m/min	11,210-15,730 ft/min

MODEL	BR272		BR378	
A Overall width	1880 mm	74"	2032 mm	80"
B Overall length	2159 mm	85"	2311 mm	91"
C Overall height	518 mm	20"	533 mm	21"
Cutting width	1829 mm	72"	1981 mm	78"
Maximum cutting diameter	76 mm	3"	76 mm	3"
Unit weight	508 kg	1120 lb	535 kg	1180 lb
Optimal hydraulic flow range	76-100 L/min	20-26 gpm	76-130 L/min	20-34 gpm
Optimal hydraulic pressure range	150-230 bar	2176-3340 psi	150-280 bar	2176-4065 psi
Tip speed range (depends on flow)	4554-5992 m/min	14,940-19,660 ft/min	4176-6032 m/min	13,700-19,790 ft/min

**Features:**

- **Self-leveling design** automatically levels itself when placed on the ground for consistent depth control without operator adjustments and excellent spoil retention.
- **Two wear resistant skid plates** remain parallel to the ground for optimum stability.
- **Hydraulic side-shift** permits close planing to curbs, walls and other obstructions.
- **Independent left/right depth control** allows maximum drum depths to be adjusted independently on each skid. The gauges are easily viewable from the cab. Independent depth control is mechanical on standard flow planers and hydraulic on high flow planers.
- **Max Pro Pressure gauge** provides operator feedback to adjust speed for maximum productivity in changing material loads. Gauge displays planer performance in real-time conditions and is visible from the cab. Standard on XHP models.
- **Float, spring tilt and hydraulic tilt** enables planers to follow the contour of the surface. Float is activated by a knob and is only available on high flow and XHP planers. Spring tilt and hydraulic tilt enable planers to oscillate for angled cuts. Tilt is hydraulically controlled on high flow models and spring controlled on standard flow planers.
- **Direct drive on standard flow** models features a variable speed, unidirectional, gerotor style hydraulic motor.
- **Direct drive on high flow and XHP** models features a hydraulic radial piston motor to ensure maximum cutting rate and drum torque for optimal production performance and efficiency.
- **Optional concrete bits and water sprinkler kits** are available for all models.
- **Cat XT-3 and medium pressure hose, couplings and O-ring face seals** provide superior, leak-free performance and reliability.
- **Quick coupler** with rugged, opposing edge design holds the work tool securely and allows the operator to quickly change from one high performance Cat Work Tool to another.

**Conical Bits:** Cold planer drums are designed with an optimal bit pattern to provide maximum cutting performance and efficiency, while ensuring superior surface texture. Standard all-purpose tungsten carbide inserted conical bits provide all-purpose planing in most applications.

### Market Opportunities

- **Infrastructure/Heavy Construction** — Skid steer mounted cold planers are frequently used on bridges to remove pavement where large dedicated planers are restricted due to weight.
- **Concrete/Masonry (Including Asphalt/Paving)** — Cold planers are used extensively by paving contractors in urban and rural settings to remove damaged pavement prior to overlay, remove excess pavement, provide specific surface texture (skid resistance), remove traffic lane stripes and re-establish proper draining characteristics of pavement.
- **Governmental/Municipalities (Street and Road Maintenance)** — Cold planers are ideal for urban road and parking lot maintenance departments to remove cracked or deteriorated pavement, milling bumps or imperfections in expanded pavement.

**Cold planers** are highly utilized work tools for specialized applications. They are often used in conjunction with a bucket and broom.

### Machine Compatibility

Cold Planer Model	Machine Models
<b>PC104B</b>	216B3, 226B3, 226D, 232D, 236D, 239D, 242D, 246D, 249D, 257D, 259D, 262D, 272D2, 272D2 XHP, 277D, 279D, 287D, 289D, 297D2, 297D2 XHP, 299D2, 299D2 XHP
<b>PC205B*</b>	216B3, 226B3, 226D, 232D, 236D, 239D, 242D, 246D, 249D, 257D, 259D, 262D, 272D2, 272D2 XHP, 277D, 279D, 287D, 289D, 297D2, 297D2 XHP, 299D2, 299D2 XHP
<b>PC305B#</b>	226B3, 226D, 232D, 236D, 239D, 242D, 246D, 249D, 257D, 259D, 262D, 272D2, 272D2 XHP, 277D, 279D, 287D, 289D, 297D2, 297D2 XHP, 299D2, 299D2 XHP
<b>PC306B#</b>	226B3, 226D, 232D, 236D, 239D, 242D, 246D, 249D, 257D, 259D, 262D, 272D2, 272D2 XHP, 277D, 279D, 287D, 289D, 297D2, 297D2 XHP, 299D2, 299D2 XHP
<b>PC310B#</b>	246D, 257D, 259D, 262D, 272D2, 272D2 XHP, 277D, 279D, 287D, 289D, 297D2, 297D2 XHP, 299D2, 299D2 XHP
<b>PC408B</b>	272D2 XHP, 297D2 XHP, 299D2 XHP
<b>PC412B</b>	272D2 XHP, 297D2 XHP, 299D2 XHP

\*Requires high flow option on machine. Operates in standard flow on high flow XPS or XHP option machines.

#Requires high flow XPS option on machine. Operates in high flow XPS on XHP machines.

**Skid Steer Loaders**  
**Multi Terrain Loaders**  
**Compact Track Loaders**

**WorkTools**  
**● Cold Planers**

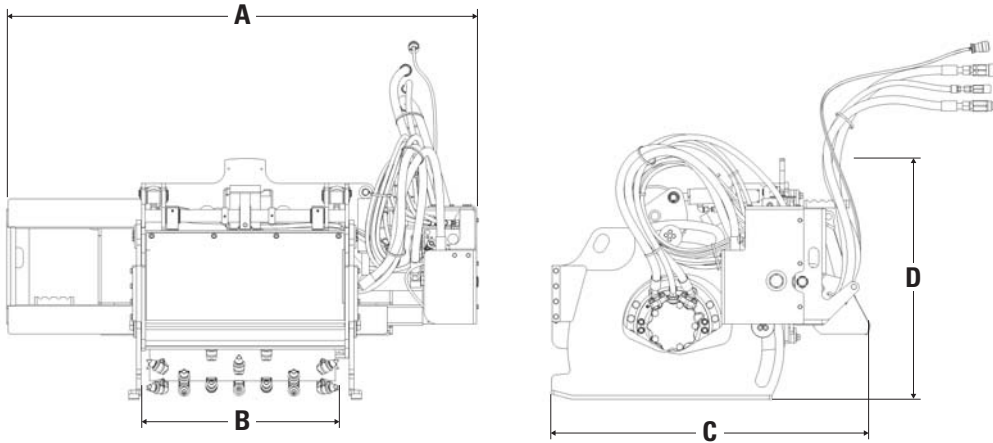

<b>MODEL</b>	<b>PC104B</b>		<b>PC205B</b>	
<b>A</b> Overall width	1730 mm	<b>68"</b>	1730 mm	<b>68"</b>
<b>B</b> Maximum drum width	350 mm	<b>14"</b>	450 mm	<b>18"</b>
Optional drum widths (depths)	400 (150) mm	<b>16 (6)"</b>	80 (200) mm	<b>3 (8)"</b>
			152 (200) mm	<b>6 (8)"</b>
			203 (200) mm	<b>8 (8)"</b>
			305 (200) mm	<b>12 (8)"</b>
			350 (200) mm	<b>14 (8)"</b>
			400 (200) mm	<b>16 (8)"</b>
			450 (150) mm	<b>18 (6)"</b>
<b>C</b> Length	1120 mm	<b>44"</b>	1184 mm	<b>47"</b>
<b>D</b> Overall height	950 mm	<b>37"</b>	1080 mm	<b>43"</b>
Weight	670 kg	<b>1474 lb</b>	730 kg	<b>1606 lb</b>
Drive method	<b>Direct drive</b>		<b>Direct drive</b>	
Optimal hydraulic flow range	60-80 L/min	<b>16-21 gpm</b>	80-115 L/min	<b>21-31 gpm</b>
Optimal hydraulic pressure	230 bar	<b>3330 psi</b>	230 bar	<b>3330 psi</b>
Drum torque @ max. pressure	1350 N·m	<b>996 lb-ft</b>	2047 N·m	<b>1510 lb-ft</b>
Drum speed @ max. flow	<b>150-200 RPM</b>		<b>142-205 RPM</b>	
Number of conical bits	<b>42 per 350 mm</b>		<b>48 per 450 mm</b>	
	<b>13.8" drum</b>		<b>18" drum</b>	
Standard bit type	<b>All purpose</b>		<b>All purpose</b>	
Maximum depth of cut	150 mm	<b>6"</b>	150 mm	<b>6"</b>
Tilt angle range	<b>±8.5°</b>		<b>±8.5°</b>	
Side shift travel	650 mm	<b>26"</b>	650 mm	<b>26"</b>

- Work Tools
- Cold Planers

**Skid Steer Loaders**  
**Multi Terrain Loaders**  
**Compact Track Loaders**

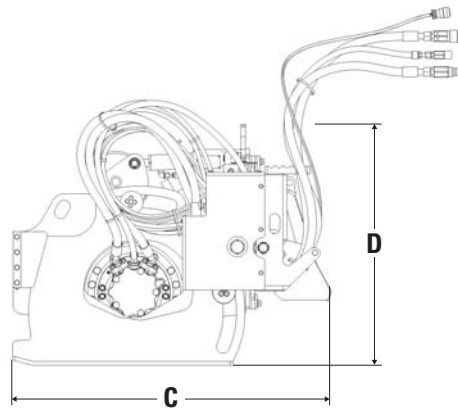
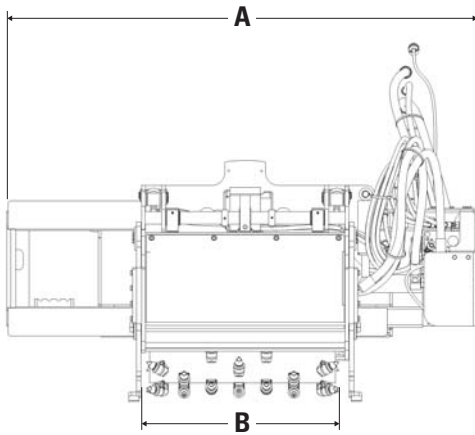

MODEL	PC305B		PC306B	
<b>A</b> Overall width	1858 mm	73"	1858 mm	73"
<b>B</b> Maximum drum width	450 mm	18"	600 mm	24"
Optional drum widths (depths)	80 (200) mm	3 (8)"	80 (200) mm	3 (8)"
	152 (200) mm	6 (8)"	152 (200) mm	6 (8)"
	203 (200) mm	8 (8)"	203 (200) mm	8 (8)"
	305 (200) mm	12 (8)"	305 (200) mm	12 (8)"
	350 (200) mm	14 (8)"	350 (200) mm	14 (8)"
	400 (200) mm	16 (8)"	400 (200) mm	16 (8)"
	450 (150) mm	18 (6)"	450 (150) mm	18 (6)"
	600 (180) mm	24 (7)"	600 (180) mm	24 (7)"
<b>C</b> Length	1240 mm	49"	1240 mm	49"
<b>D</b> Overall height	1100 mm	43"	1100 mm	43"
Weight	860 kg	1896 lb	935 kg	2061 lb
Drive method	<b>Planetary drive</b>		<b>Direct drive</b>	
Optimal hydraulic flow range	100-125 L/min	26-33 gpm	100-125 L/min	26-33 gpm
Optimal hydraulic pressure range	230-280 bar	3330-4000 psi	230-280 bar	3330-4000 psi
Drum torque @ max. pressure	3470 N·m	2558 lb-ft	3470 N·m	2558 lb-ft
Drum speed @ max. flow	<b>160 RPM</b>		<b>160 RPM</b>	
Number of conical bits	<b>48 per 450 mm</b>		<b>60 per 600 mm</b>	
	<b>18" drum</b>		<b>24" drum</b>	
Standard bit type	<b>All purpose</b>		<b>All purpose</b>	
Maximum depth of cut	170 mm	7"	170 mm	7"
Tilt angle range	<b>±8°</b>		<b>±8°</b>	
Side shift travel	750 mm	30"	750 mm	30"

**Skid Steer Loaders  
Multi Terrain Loaders  
Compact Track Loaders**

**WorkTools**  
● **Cold Planers**

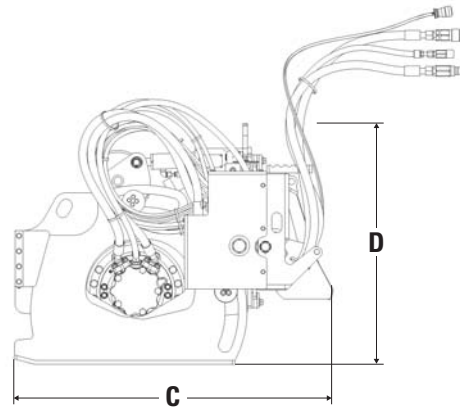
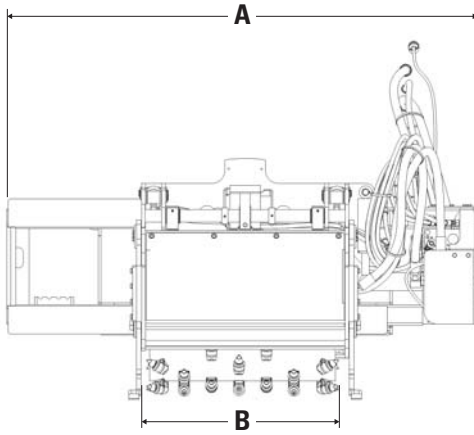

MODEL	PC310B		PC408B		PC412B	
<b>A</b> Overall width	1858 mm	<b>73"</b>	1858 mm	<b>73"</b>	1858 mm	<b>73"</b>
<b>B</b> Maximum drum width	1000 mm	<b>39"</b>	750 mm	<b>30"</b>	1200 mm	<b>47"</b>
Optional drum widths (depths)	—		80 (200) mm	<b>3 (8)"</b>	—	
			152 (200) mm	<b>6 (8)"</b>		
			203 (200) mm	<b>8 (8)"</b>		
			305 (200) mm	<b>12 (8)"</b>		
			350 (200) mm	<b>14 (8)"</b>		
			400 (200) mm	<b>16 (8)"</b>		
			450 (200) mm	<b>18 (8)"</b>		
			610 (178) mm	<b>24 (7)"</b>		
<b>C</b> Length	1140 mm	<b>45"</b>	1270 mm	<b>50"</b>	1140 mm	<b>45"</b>
<b>D</b> Overall height	965 mm	<b>38"</b>	1100 mm	<b>43"</b>	965 mm	<b>38"</b>
Weight	1050 kg	<b>2310 lb</b>	1050 kg	<b>2315 lb</b>	1170 kg	<b>2580 lb</b>
Drive method	<b>Direct drive</b>		<b>Direct drive</b>		<b>Direct drive</b>	
Optimal hydraulic flow	125 L/min	<b>33 gpm</b>	150 L/min	<b>40 gpm</b>	150 L/min	<b>40 gpm</b>
Optimal hydraulic pressure	280 bar	<b>4000 psi</b>	280 bar	<b>4000 psi</b>	280 bar	<b>4000 psi</b>
Drum torque @ max. pressure	3350 N·m	<b>2470 lb-ft</b>	3724 N·m	<b>2746 lb-ft</b>	4108 N·m	<b>3030 lb-ft</b>
Drum speed @ max. flow	<b>166 RPM</b>		<b>143 RPM</b>		<b>161 RPM</b>	
Number of conical bits	<b>78 per 1000 mm</b>		<b>60 per 750 mm</b>		<b>90 per 1200 mm</b>	
	<b>40" drum</b>		<b>30" drum</b>		<b>47" drum</b>	
Standard bit type	<b>All purpose</b>		<b>All purpose</b>		<b>All purpose</b>	
Maximum depth of cut	130 mm	<b>5"</b>	170 mm	<b>7"</b>	130 mm	<b>5"</b>
Tilt angle range	<b>±6.5°</b>		<b>±6.5°</b>		<b>±6.5°</b>	
Side shift travel	650 mm	<b>26"</b>	650 mm	<b>26"</b>	550 mm	<b>22"</b>

**Features:**

- **Two sizes available:** the 1321 mm (52") working width LT13B and the 1854 mm (73") working width LT18B. Both units efficiently utilize the standard flow auxiliary hydraulic horsepower capabilities of Cat Skid Steer Loaders.
- **Direct drive system** features two in-line motors that transmit power directly from the drive motor shaft to the tiller shaft. Power to both ends of the shaft eliminates torque twist and increased system performance.
- **Adjustable skid shoes** provide a working depth range of 25-152 mm (1"-6").
- **High strength medium carbon alloy steel tines** are hardened for maximum strength, durability and wear life in the toughest soil conditions.
- **Cat XT-3 hose and O-ring face seals** are used throughout for superior leak-free performance.

**Market Opportunities**

- **Agriculture** — Landscape tillers provide an effective work tool around the farm or orchard to breakup and condition soil prior to planting.
- **Building/General Construction** — Landscape tillers can be used on construction sites to level soil and remove ruts.
- **Landscaping/Landscape Maintenance** — Landscape tillers are ideal for mixing and composting soils for improved seedbeds, soil stabilization and soil preparation prior to landscaping and laying sod.
- **Governmental/Municipalities** — Landscape tillers are ideal for city maintenance departments and parks to recondition, level and stabilize soil after utility work or prior to yearly landscaping.

**Landscape tillers** are productive work tools for specialized applications. They are often used in conjunction with a bucket, landscape rake and auger.

**Machine Compatibility**

Landscape Tiller Model	Machine Models
LT13B	216B3, 226B3, 226D, 232D, 236D, 239D, 242D, 246D, 249D, 257D, 259D, 262D, 272D2, 272D2 XHP, 277D, 279D, 287D, 289D, 297D2, 297D2 XHP, 299D2, 299D2 XHP
LT18B	236D, 246D, 249D, 257D, 259D, 262D, 272D2, 272D2 XHP, 277D, 279D, 287D, 289D, 297D2, 297D2 XHP, 299D2, 299D2 XHP



**Skid Steer Loaders**  
**Multi Terrain Loaders**  
**Compact Track Loaders**

**WorkTools**  
 ● **Landscape Tillers**

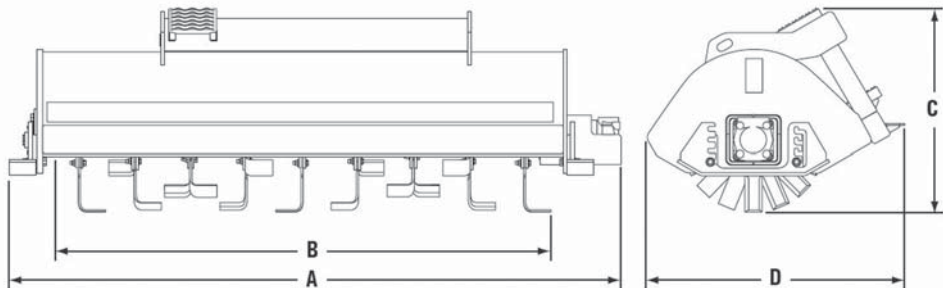

<b>MODEL</b>	<b>LT13B</b>		<b>LT18B</b>	
<b>A</b> Overall width	1788 mm	<b>70.5"</b>	2271 mm	<b>89.5"</b>
<b>B</b> Working width	1321 mm	<b>52"</b>	1847 mm	<b>73"</b>
<b>C</b> Height	755 mm	<b>30"</b>	755 mm	<b>30"</b>
<b>D</b> Length	956 mm	<b>38"</b>	956 mm	<b>38"</b>
Working depth range	25-152 mm	<b>1"-6"</b>	25-152 mm	<b>1"-6"</b>
Weight	340 kg	<b>750 lb</b>	420 kg	<b>926 lb</b>
Drive method	<b>Direct drive</b>		<b>Direct drive</b>	
Number of motors	<b>Two in-line</b>		<b>Two in-line</b>	
Hydraulic flow range	60-86 L/min	<b>16-23 gpm</b>	60-86 L/min	<b>16-23 gpm</b>
Hydraulic pressure	230 bar	<b>3340 psi</b>	230 bar	<b>3340 psi</b>
Motor displacement	629.1 cm <sup>3</sup> /rev	<b>38.4 in<sup>3</sup>/rev</b>	629.1 cm <sup>3</sup> /rev	<b>38.4 in<sup>3</sup>/rev</b>
Drum speed @ maximum flow	127 RPM @ 80 L/min	<b>127 RPM @ 21 gpm</b>	127 RPM @ 80 L/min	<b>127 RPM @ 21 gpm</b>
Fasteners	<b>Cat</b>		<b>Cat</b>	
Hydraulic hose	<b>Cat XT-3 ES</b>		<b>Cat XT-3 ES</b>	
Number of tines	<b>24</b>		<b>36</b>	

**Features:**

- **Two sizes available:** the 1576 mm (62") working width LR15B and the 1883 mm (74") working width LR18B. Both units efficiently utilize the standard flow auxiliary hydraulic horsepower capabilities of Cat Skid Steer Loaders.
- **Chain reduction drive system** features #80H roller chain for strength and durability, a variable speed unidirectional gerotor motor for maximum performance and cartridge relief valve for system protection.
- **Durable #2060H conveyor chain** provides strength, durability and long life in a variety of soil conditions.
- **High strength medium carbon alloy steel teeth** are hardened for maximum strength, durability and wear life in the toughest soil conditions.
- **Quick dumping capability** is accomplished with a poppet check valve. Once the hopper bucket is full, simply reverse flow to actuate the rake head and dump the bucket.
- **Cat XT-3 hose and O-ring face seals** are used throughout for superior leak-free performance.

**Market Opportunities**

- **Agriculture** — Landscape rakes provide an effective work tool around the farm or nursery to condition, level and remove rock and foreign material from soil prior to planting.
- **Building/General Construction** — Landscape rakes can be used on construction sites to level and remove debris from soil prior to landscaping and seeding.
- **Demolition** — Landscape rakes provide an excellent means to clean up loose material after the demolition work is complete.
- **Landscaping/Landscape Maintenance** — Landscape rakes are ideal for aerating, conditioning, leveling and removing rocks from soil prior to seeding or laying sod. They also are ideal for conditioning and cleaning baseball fields.

Landscape rakes are productive work tools for specialized applications. They are often used in conjunction with a bucket, landscape tiller and auger.

**Machine Compatibility**

The following are the recommended and approved Cat machine/Landscape Rake combinations for maximum system performance.

Landscape Rake Model	Machine Models*
LR15B	216B3, 226B3, 226D, 232D, 236D, 239D, 242D, 246D, 249D, 257D, 259D, 262D, 272D2, 272D2 XHP, 277D, 279D, 287D, 289D, 297D2, 297D2 XHP, 299D2, 299D2 XHP
LR18B	236D, 246D, 249D, 257D, 259D, 262D, 272D2, 272D2 XHP, 277D, 279D, 287D, 289D, 297D2, 297D2 XHP, 299D2, 299D2 XHP

\*Lift restriction! Do not raise lift arm — work tool hinge higher than 1 m (3 ft) above the ground. Tipping can result.

**Skid Steer Loaders  
Multi Terrain Loaders  
Compact Track Loaders**

**WorkTools**  
● **Landscape Rakes**

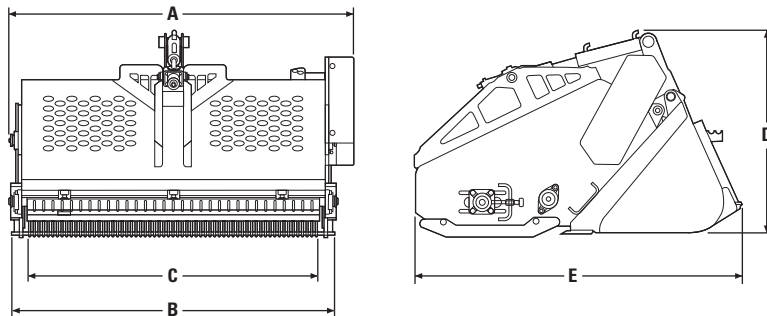

MODEL	LR15B		LR18B	
<b>A</b> Overall width	1683 mm	<b>66"</b>	1990 mm	<b>78"</b>
<b>B</b> Working width	1576 mm	<b>62"</b>	1883 mm	<b>74"</b>
<b>C</b> Raking width	1384 mm	<b>55"</b>	1655 mm	<b>65"</b>
<b>D</b> Height	989 mm	<b>39"</b>	989 mm	<b>39"</b>
<b>E</b> Length	1620 mm	<b>64"</b>	1620 mm	<b>64"</b>
Weight	595 kg	<b>1312 lb</b>	653 kg	<b>1440 lb</b>
Drive method	<b>Chain reduction</b>		<b>Chain reduction</b>	
Drive chain	<b>#80H</b>		<b>#80H</b>	
Conveyor chain	<b>#2060H</b>		<b>#2060H</b>	
Hydraulic flow range	42-86 L/min	<b>11-23 gpm</b>	42-86 L/min	<b>11-23 gpm</b>
Hydraulic pressure range	145-235 bar	<b>2100-3400 psi</b>	145-235 bar	<b>2100-3400 psi</b>
Bucket capacity (struck)*	0.31 m <sup>3</sup>	<b>0.4 yd<sup>3</sup></b>	0.34 m <sup>3</sup>	<b>0.44 yd<sup>3</sup></b>
Motor displacement	315 cm <sup>3</sup> /rev	<b>19.2 in<sup>3</sup>/rev</b>	315 cm <sup>3</sup> /rev	<b>19.2 in<sup>3</sup>/rev</b>
Driven shaft speed	165 RPM @ 80 L/min	<b>165 RPM @ 21 gpm</b>	165 RPM @ 80 L/min	<b>165 RPM @ 21 gpm</b>
Torque @ 230 bar ( <b>3336 psi</b> )	1774 N·m	<b>1310 lb-ft</b>	1774 N·m	<b>1310 lb-ft</b>
Fasteners	<b>Cat</b>		<b>Cat</b>	
Hydraulic hose	<b>Cat XT-3 ES</b>		<b>Cat XT-3 ES</b>	
Number of teeth	<b>372</b>		<b>444</b>	
Rock size	19-152 mm	<b>0.75"-6"</b>	19-152 mm	<b>0.75"-6"</b>

\*Rated struck capacities shown as per ISO 7546: 1983 and SAE J742 FEB85.

**Features:**

- **Dual speed, axial piston hydraulic motor** provides smooth, efficient performance while delivering optimal torque under changing material loads.
- **Rugged mulching head** processes trees up to 200 mm (8 in) diameter for effective forestry clearing applications.
- **Single bolt retention, fixed tooth balanced rotor** provides excellent operating efficiency at high speed. Single bolt retention provides quick tooth replacement.
- **Adjustable push frame** is standard equipment and provides the ability to position trees to allow for optimum cutting and efficiency. In forestry operation it also provides operator cab protection.
- **Pressure gauge** provides operator feedback to adjust speed for maximum productivity in changing material loads. Gauge displays planer performance in real-time conditions and is visible from the cab. Available on XHP models.
- **Heavy-duty bearings** extend work tool life.
- **Hydraulically operated front hood** is standard, allowing trees to be cut when opened and allows dense vegetation to be mulched.
- **Polychain belt drive** provides abrasion resistance, shock load capability and protects against debris blockage.
- **Rear chain guard protection** reduces spread of material.
- **Rigid, robust tempered steel construction** provides fully guarded protection in tough applications.
- **Cat XT-3 ES hose, couplings and O-ring face seals** provide superior, leak-free performance and reliability. All hoses are wrapped with nylon woven cordura sleeving for added operator protection. Hydraulic quick disconnects enable fast tool changes.
- **Quick coupler** with rugged, opposing edge design holds the work tool securely and allows the operator to quickly change from one high performance Cat Work Tool to another.

The **Cat Mulcher** is designed for high-performance cutting, and mulching vegetation and undergrowth from typical forested terrain. The hydraulic mulcher reduces saplings, shrubs and downed trees into mulched material, making it ideal for environmental maintenance, such as creating fire lanes. Other applications include: reclaiming untilled land, removing foliage from building construction sites, and shredding pruned material and organic waste for biomass production.

**Machine Compatibility**

Mulcher Model	Machine Models
<b>HM315B*</b>	246D, 262D, 272D2, 272D2 XHP, 277D, 279D, 287D, 289D, 297D2, 297D2 XHP, 299D2, 299D2 XHP
<b>HM415B</b>	272D2 XHP, 297D2 XHP, 299D2 XHP

\*Requires high flow XPS option on machine. Operates in high flow XPS on XHP machines.  
Debris Barrier package recommended.

**Skid Steer Loaders**  
**Multi Terrain Loaders**  
**Compact Track Loaders**

**WorkTools**  
 ● **Mulchers**

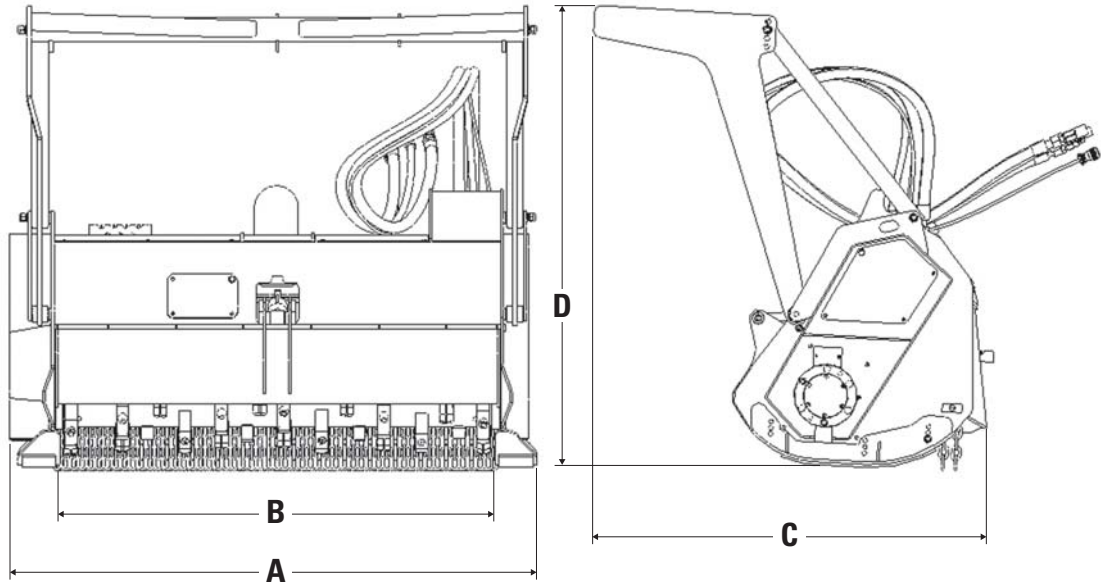

<b>MODEL</b>	<b>HM315B</b>		<b>HM415B</b>	
<b>A</b> Overall width	1840 mm	<b>72"</b>	1840 mm	<b>72"</b>
<b>B</b> Working width	1465 mm	<b>58"</b>	1465 mm	<b>58"</b>
<b>C</b> Length	1470 mm	<b>58"</b>	1470 mm	<b>58"</b>
<b>D</b> Overall height	1610 mm	<b>63"</b>	1610 mm	<b>63"</b>
Weight	1165 kg	<b>2564 lb</b>	1165 kg	<b>2564 lb</b>
Drive method	<b>Polychain belt</b>		<b>Polychain belt</b>	
Hydraulic motor type	<b>Dual speed axial piston</b>		<b>Dual speed axial piston</b>	
Hydraulic flow range	120-137 L/min	<b>31.5-36 gpm</b>	137-155 L/min	<b>36-41 gpm</b>
Hydraulic pressure range	195-350 bar	<b>2828-5075 psi</b>	195-350 bar	<b>2828-5075 psi</b>
Drum speed range	<b>2100-2400 RPM</b>		<b>1900-2200 RPM</b>	
Number of teeth	<b>34</b>		<b>34</b>	
Maximum diameter of material to be cut	200 mm	<b>8"</b>	200 mm	<b>8"</b>

**Features:**

- **A heavy-duty frame, pivot plate and attachment plate** are featured for reliable operation in rugged terrain and abusive soil conditions.
- **Pure carbide, blunt shaped teeth** create a dimpled sub-surface to ensure the best possible seedbed sub-base fracture pattern.
- **Two-position winged endplates** allow close raking to side walks or foundations. They can remain parallel, even during angling, for smoother plowing.
- **Convenient, heavy-duty, deep skid-resistant step** and a generous cab allow for easy operator entry and exit.
- **Dual independently adjustable gauge wheels** allow for skim passes for over-seeding or adjust to cut drainage grades.
- **Cat XT-3 ES hose, couplings and O-ring face seals** provide superior, leak-free performance and reliability. All hoses are wrapped with nylon woven cordura sleeving for added operator protection. Hydraulic quick disconnects enable fast tool changes.
- **Quick coupler** with rugged, opposing edge design holds the work tool securely and allows the operator to quickly change from one high performance Cat Work Tool to another.

**Cat Power Box Rakes** are ideal for clearing and preparing soil in general construction trench restoration, golf course construction and athletic field maintenance. They offer the versatility to de-thatch, remove old lawns and weeds, grade, level, rake, remove debris and prepare seedbeds with one work tool. Their angling ability allows the operator to windrow collected debris for easy pickup and removal. The consistent milling action creates an ideal seedbed for great germination results, laying the groundwork for a perfect lawn. Wet, dry, weedy, hard and rocky soil can be dried, flattened, pulverized and conditioned for seed in one step.

**Machine Compatibility**

Power Box Rake Model	Machine Models
<b>PR172</b>	216B3, 226B3, 226D, 232D, 236D, 239D, 242D, 246D, 249D, 257D, 259D, 262D, 272D2, 272D2 XHP, 277D, 279D, 287D, 289D, 297D2, 297D2 XHP, 299D2, 299D2 XHP
<b>PR184</b>	216B3, 226B3, 226D, 232D, 236D, 239D, 242D, 246D, 249D, 257D, 259D, 262D, 272D2, 272D2 XHP, 277D, 279D, 287D, 289D, 297D2, 297D2 XHP, 299D2, 299D2 XHP
<b>PR190</b>	216B3, 226B3, 226D, 232D, 236D, 239D, 242D, 246D, 249D, 257D, 259D, 262D, 272D2, 272D2 XHP, 277D, 279D, 287D, 289D, 297D2, 297D2 XHP, 299D2, 299D2 XHP

**Skid Steer Loaders  
Multi Terrain Loaders  
Compact Track Loaders**

**WorkTools**  
● **Power Box Rakes**

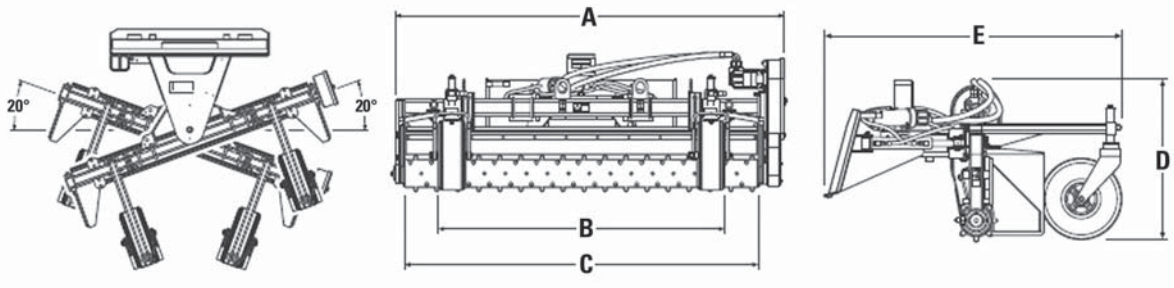

MODEL	PR172		PR184		PR190	
A Overall width	2057 mm	<b>81"</b>	2362 mm	<b>93"</b>	2515 mm	<b>99"</b>
B Width over tires	1386 mm	<b>55"</b>	1732 mm	<b>68"</b>	1845 mm	<b>73"</b>
C Roller width	1829 mm	<b>72"</b>	2134 mm	<b>84"</b>	2286 mm	<b>90"</b>
D Overall height	847 mm	<b>34"</b>	847 mm	<b>34"</b>	953 mm	<b>38"</b>
E Overall length	1626 mm	<b>64"</b>	1626 mm	<b>64"</b>	1626 mm	<b>64"</b>
Raking width at maximum angle	1727 mm	<b>68"</b>	2007 mm	<b>79"</b>	2159 mm	<b>85"</b>
Unit weight (Manual)	408 kg	<b>900 lb</b>	465 kg	<b>1026 lb</b>	588 kg	<b>1296 lb</b>
Unit weight (Hydraulic)	420 kg	<b>925 lb</b>	476 kg	<b>1050 lb</b>	599 kg	<b>1320 lb</b>
Maximum working angle	<b>20°</b>		<b>20°</b>		<b>20°</b>	
Optimal hydraulic flow	49-86 L/min	<b>13-23 gpm</b>	57-86 L/min	<b>15-23 gpm</b>	57-86 L/min	<b>15-23 gpm</b>
Optimal hydraulic pressure	230 bar	<b>3340 psi</b>	230 bar	<b>3340 psi</b>	230 bar	<b>3340 psi</b>

### Features:

- **Direct drive system** features a variable speed, bidirectional, gerotor style motor that delivers optimal chain speed, chain pull and torque for maximum trenching performance in a broad range of soil types.
- **Durable double standard anti-backflex chain** is standard for strength, durability and long life in all soil types.
- **Standard boom lengths** for all-purpose performance. Replaceable weld-on wear strips extend boom life.
- **Hardfaced, tungsten carbide steel cupped teeth** are standard for long life in many soil conditions. Teeth are spaced for optimum digging performance in most soil.
- **Hydraulic or manual side-shift on the T6B and T9B** provides close trenching flexibility near structures or obstructions.
- **Hydraulic side-shift on the T15B** is controlled from the operator's compartment using the standard flow auxiliary hydraulic circuit selector control.
- **Optional cutting widths and crumber bars** are available for wider trenching requirements and loose material removal.
- **Cat XT-3 hose and O-ring face seals** are used throughout for superior leak-free performance.

### Market Opportunities

- **Agriculture** — Trenchers provide an effective work tool around the farm or nursery to cut trenches for water lines, electrical cables and other utilities.
- **Building/General Construction** — Trenchers are often used on construction sites to cut trenches for plumbing, electrical, telephone and cable television lines.
- **Landscaping/Landscape Maintenance** — Trenchers are popular landscaping work tools when installing irrigation and water sprinkler systems. They can also be used to remove roots that grow too close to buildings or cart paths. Landscapers, golf course maintenance departments and irrigation contractors are prime users.
- **Specialty Trades/Utilities** — Trenchers are excellent work tools for specialty trades and utility contractors that need to bury water and gas pipe, conduit, electrical, telephone and cable television lines.

**Trenchers** are productive work tools for specialized applications. They are often used in conjunction with a bucket and auger.



**Machine Compatibility**

Trencher Model	Machine Models
<b>T6B</b>	216B3, 226B3, 226D, 232D, 236D, 239D, 242D, 246D, 249D, 257D, 259D, 262D, 272D2, 272D2 XHP, 277D, 279D, 287D, 289D, 297D2, 297D2 XHP, 299D2, 299D2 XHP
<b>T9B</b>	216B3, 226B3, 226D, 232D, 236D, 239D, 242D, 246D, 249D, 257D, 259D, 262D, 272D2, 272D2 XHP, 277D, 279D, 287D, 289D, 297D2, 297D2 XHP, 299D2, 299D2 XHP
<b>T15B*</b>	226B3, 226D, 232D, 239D, 242D, 246D, 249D, 257D, 259D, 262D, 272D2, 272D2 XHP, 277D, 279D, 287D, 289D, 297D2, 297D2 XHP, 299D2, 299D2 XHP

\*Requires high flow or high flow XPS option on machine.

**T6B/T9B Trencher**

Theoretical Drive Shaft Torque			
Pressure		Torque	
bar	psi	N-m	lb-ft
145	2100	848	625
152	2200	889	655
158	2300	924	681
166	2400	971	716
172	2500	1006	741
179	2600	1047	772
186	2700	1088	802
193	2800	1129	832
200	2900	1170	863
207	3000	1211	893
214	3100	1252	923
220	3200	1287	949
227	3300	1328	979

**T15B Trencher**

Theoretical Drive Shaft Torque			
Pressure		Torque	
bar	psi	N-m	lb-ft
207	3000	1916	1413
214	3100	1981	1461
220	3200	2036	1501
227	3300	2101	1549
235	3400	2175	1604
242	3500	2240	1652
248	3600	2295	1692
255	3700	2360	1740
262	3800	2425	1788
269	3900	2490	1836
276	4000	2555	1884
283	4100	2619	1931
290	4200	2684	1979
297	4300	2749	2027
304	4400	2814	2075
311	4500	2878	2122

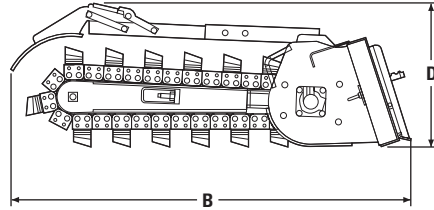
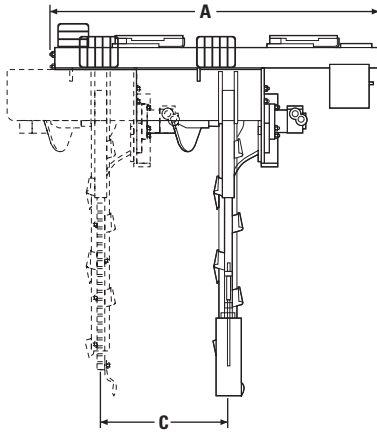

MODEL	T6B		T9B		T15B	
<b>A</b> Overall width	1426 mm	<b>56"</b>	1901 mm	<b>74.8"</b>	1901 mm	<b>74.8"</b>
<b>B</b> Overall length	2337 mm	<b>92"</b>	2705 mm	<b>106.5"</b>	3010 mm	<b>118.5"</b>
<b>C</b> Side shift travel (center to right)	419 mm	<b>16.5"</b>	559 mm	<b>22"</b>	559 mm	<b>22"</b>
<b>D</b> Height	786 mm	<b>30.9"</b>	786 mm	<b>30.9"</b>	786 mm	<b>30.9"</b>
Max. auger clearance	534 mm	<b>21"</b>	534 mm	<b>21"</b>	534 mm	<b>21"</b>
Spoil auger diameter	457 mm	<b>18"</b>	457 mm	<b>18"</b>	457 mm	<b>18"</b>
Standard boom length	914 mm	<b>36"</b>	1219 mm	<b>48"</b>	1524 mm	<b>60"</b>
Weight	397 kg*	<b>875 lb*</b>	551 kg**	<b>1215 lb**</b>	601 kg***	<b>1325 lb***</b>
Optimal hydraulic flow range	42-86 L/min	<b>11-23 gpm</b>	42-86 L/min	<b>11-23 gpm</b>	95-152 L/min	<b>25-40 gpm</b>
Optimal hydraulic pressure range	145-235 bar	<b>2100-3400 psi</b>	145-235 bar	<b>2100-3400 psi</b>	207-310 bar	<b>3000-4500 psi</b>
Motor displacement	393.9 cm <sup>3</sup>	<b>24.0 in<sup>3</sup></b>	393.9 cm <sup>3</sup>	<b>24.0 in<sup>3</sup></b>	629.1 cm <sup>3</sup>	<b>38.4 in<sup>3</sup></b>
Theoretical drive shaft torque	1447 N·m	<b>1068 lb-ft</b>	1447 N·m	<b>1068 lb-ft</b>	2905 N·m	<b>2144 lb-ft</b>
Chain pull @ max. pressure <sup>1</sup>	1207 kg	<b>2661 lb</b>	1207 kg	<b>2661 lb</b>	2424 kg	<b>5344 lb</b>
Chain speed @ max. flow <sup>2</sup>	155 m/min	<b>508.5 ft/min</b>	155 m/min	<b>508.5 ft/min</b>	158 m/min	<b>518.3 ft/min</b>
Drive shaft speed @ max. flow	<b>203 RPM @</b>		<b>203 RPM @</b>		<b>207 RPM @</b>	
	80 L/min	<b>21 gpm</b>	80 L/min	<b>21 gpm</b>	129 L/min	<b>34 gpm</b>
Optional cutting widths	152, 203,	<b>(6", 8",</b>	152, 203,	<b>(6", 8",</b>	152, 203,	<b>(6", 8",</b>
	254, 305 mm	<b>10", 12")</b>	254, 305 mm	<b>10", 12")</b>	254, 305 mm	<b>10", 12")</b>

\*T6B bare configuration, no chain.

\*\*T9B equipped with 1219 mm (48") boom, hydraulic side shift control, double standard anti-backflex chain, 203 mm (8") cutting width, 50/50 carbide/cup chain.

\*\*\*T15B equipped with 1524 mm (60") boom, double standard anti-backflex chain, 203 mm (8") cutting width, 50/50 carbide/cup chain.

<sup>1</sup>Max. Pressure: T6B, T9B — 230 bar (3335 psi), T15B — 290 bar (4206 psi).

<sup>2</sup>Max. Flow: T6B, T9B — 80 L/min (21 gpm), T15B — 130 L/min (34 gpm).

**Features:**

- **Caterpillar exclusive vibratory pod design** delivers desired balance between frequency and amplitude to provide a superior matte finish. Pod-style weight housings are factory sealed for longer bearing life and easy serviceability.
- **Higher compaction forces** provide twice the compaction force of the original design requiring fewer passes for greater productivity.
- **Replaceable rubber mounts** isolate vibration and enhance vibratory capabilities.
- **Durable high-strength steel drums** are roll formed and finish welded for a smoother surface and longer life.
- **Pivoting interface** allows the drum to oscillate  $\pm 15^\circ$  and follow the contour of the ground.
- **Cat XT-3 hose and O-ring face seals** are used throughout for superior leak-free performance.

**Market Opportunities**

- **Building/General Construction** — Vibratory compactors can be used on construction sites to level and compact soil around building foundations after backfilling.
- **Governmental/Municipalities (Street and Road Maintenance)** — Vibratory compactors are useful work tools for compacting soil and crushed rock prior to paving or pouring concrete. They are also useful for compacting small areas of asphalt (pothole repair).
- **Landscaping/Landscape Maintenance** — Vibratory compactors are used by landscaping contractors after installing irrigation and water sprinkler systems. Golf course maintenance departments will often use this product to compact greens and fairways.
- **Paving** — Vibratory compactors are used by paving contractors for smaller paving jobs (compacting soil and crushed stone), compacting hot patch (pot hole repair) or compacting material in tight areas where a dedicated roller can't maneuver.
- **Specialty Trades/Utilities** — Vibratory compactors are ideal for compacting back-filled soil after trenching and backhoe work.

**Vibratory compactors** are productive work tools for specialized applications. They are often used in conjunction with a bucket, cold planer and trencher.

**Machine Compatibility**

<b>Vibratory Compactor Model</b>	<b>Machine Models*</b>
<b>CV16B</b>	216B3, 226B3, 226D, 232D, 236D, 239D, 242D, 246D, 249D, 257D, 259D, 262D, 272D2, 272D2 XHP, 277D, 279D, 287D, 289D, 297D2, 297D2 XHP, 299D2, 299D2 XHP
<b>CV18B</b>	246D, 262D, 272D2, 272D2 XHP, 277D, 279D, 287D, 289D, 297D2, 297D2 XHP, 299D2, 299D2 XHP

\*Lift restriction! Do not raise lift arm — work tool coupler interface higher than 1 m (3 ft) above the ground. Tipping can result.

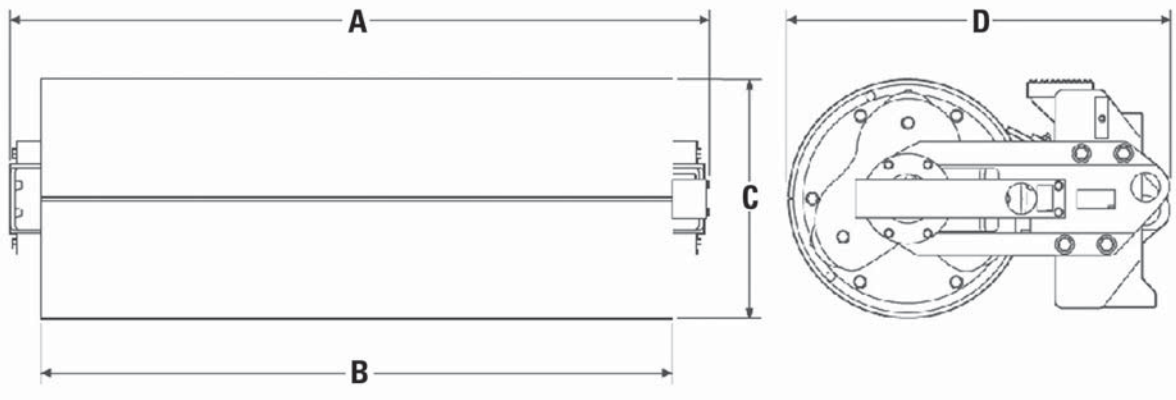

MODEL	CV16B		CV18B	
<b>A</b> Overall width	1854 mm	73"	2032 mm	80"
<b>B</b> Drum width	1676 mm	66"	1854 mm	73"
<b>C</b> Overall height	634 mm	25"	634 mm	25"
<b>D</b> Overall length	1009 mm	40"	1009 mm	40"
Drum diameter	634 mm	25"	634 mm	25"
Weight	936 kg	2063 lb	970 kg	2138 lb
Drive method	Direct drive		Direct drive	
Number of motors	1		1	
Motor size	28.2 cm <sup>3</sup>	1.72 in <sup>3</sup>	28.2 cm <sup>3</sup>	1.72 in <sup>3</sup>
Hydraulic flow range	42-86 L/min	11-23 gpm	42-86 L/min	11-23 gpm
Hydraulic pressure range	145-235 bar	2100-3400 psi	145-235 bar	2100-3400 psi
Drum oscillation range	±15°		±15°	
Drum frequency @ maximum flow	2946 vibrations/min		2946 vibrations/min	
Dynamic force	5399 kg	11,903 lb	5399 kg	11,903 lb
Amplitude	1.16 mm	0.046"	1.09 mm	0.043"

**Features:**

- **Pickup Brooms** sweep and deposit material into an integrated hopper bucket for easy removal and dumping. Bidirectional capabilities of the bristles allow Pickup and Utility Brooms to sweep in forward or reverse machine travel. Optimum sweeping style is in forward travel, resulting in over-the-brush pickup. Certain conditions require a dust pan style of sweeping, done in reverse travel.
- **Utility Brooms** sweep and collect light debris on smooth surfaces in forward or reverse travel. They can be adjusted for greater bristle down-force in tough applications such as sweeping course material out of a cold planer cut.
- **Angle Brooms** use a single variable speed, unidirectional gerotor style hydraulic motor, contained in a protective housing. They use a windrowing action to move loose debris ahead and to the side of the surface being swept. They can be oriented straight or angled up to 30° left or right of center in forward travel.
- **Direct drive motors** provide maximum performance and durability. Pickup and Utility Brooms use a single variable speed, bidirectional gerotor style hydraulic motor, contained in a special housing that is adjustable to compensate for bristle wear. Angle brooms use a single variable speed unidirectional gerotor style hydraulic motor contained in a protective housing.
- **Polypropylene/wire convoluted brushes** provide optimum results for sweeping. Optional all-polypropylene and all-steel wire convoluted brushes are available for specialty applications. Convoluted brush sections are available in half-kits for easy maintenance and quick replacement.
- **Drop core design** allows for quick bristle replacement without removing hydraulic hoses.
- **Quick coupler** with rugged, opposing edge design holds the work tool securely and allows the operator to quickly change from one high performance Cat Work Tool to another.

**Market Opportunities**

- **Building/General Construction** — Brooms are often found on construction sites once the construction is complete to remove and collect dirt, rock and other construction debris from driveways, sidewalks and streets.

- **Demolition** — Brooms are ideal for collecting loose dirt and debris from demolition sites.
- **Governmental/Municipalities (Street and Road Maintenance)** — Brooms are useful work tools for cleaning city streets, sidewalks and parking areas. Airport maintenance is another popular application.
- **Industrial/Recycling** — Pickup brooms are excellent for cleaning factory floors or industrial pavements.
- **Landscaping/Landscape Maintenance** — Brooms are used by landscaping contractors to clean paved surfaces after the landscaping is complete. Golf course maintenance departments will often use this product to clean cart paths, parking lots and even turf.
- **Paving** — Pickup brooms are often used by paving contractors to sweep and collect milled asphalt and concrete. Angle brooms are used to clean milled surfaces.
- **Specialty Trades/Utilities** — Brooms are often utilized by specialty trades and utility contractors to clean up after trenching and backhoe work.

**Pickup brooms** are productive work tools for specialized applications. They are often used in conjunction with a bucket, cold planer and trencher.

**Machine Compatibility**

Broom Model	Machine Models
<b>BP115C</b>	216B3, 226B3, 226D, 232D, 236D, 239D, 242D, 246D, 249D, 257D, 259D, 262D, 272D2, 272D2 XHP, 277D, 279D, 287D, 289D, 297D2, 297D2 XHP, 299D2, 299D2 XHP
<b>BP118C</b>	236D, 246D, 249D, 257D, 259D, 262D, 272D2, 272D2 XHP, 277D, 279D, 287D, 289D, 297D2, 297D2 XHP, 299D2, 299D2 XHP
<b>BA118C</b>	216B3, 226B3, 226D, 232D, 236D, 239D, 242D, 246D, 249D, 257D, 259D, 262D, 272D2, 272D2 XHP, 277D, 279D, 287D, 289D, 297D2, 297D2 XHP, 299D2, 299D2 XHP
<b>BU115</b>	216B3, 226B3, 226D, 232D, 236D, 239D, 242D, 246D, 249D, 257D, 259D, 262D, 272D2, 272D2 XHP, 277D, 279D, 287D, 289D, 297D2, 297D2 XHP, 299D2, 299D2 XHP
<b>BU118</b>	236D, 242D, 246D, 257D, 259D, 262D, 272D2, 272D2 XHP, 277D, 279D, 287D, 289D, 297D2, 297D2 XHP, 299D2, 299D2 XHP

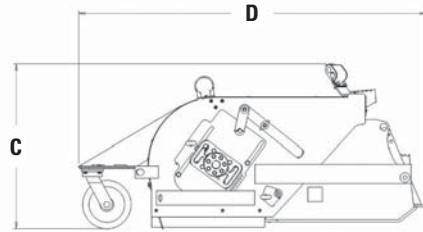
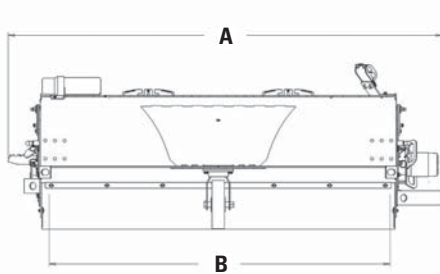

Pickup Brooms

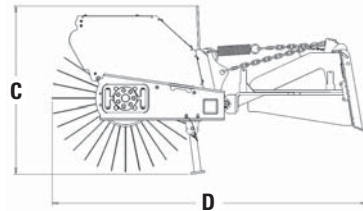
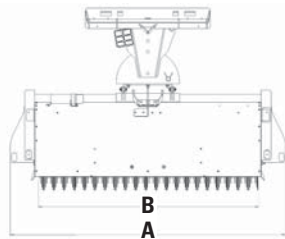
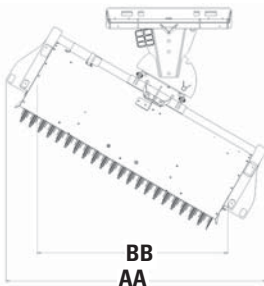

Angle Brooms

MODEL	BP115C Pickup Broom		BP118C Pickup Broom		BA118C Angle Broom	
A Overall width	1990 mm	78"	2295 mm	90"	2637 mm	104"
AA Overall width angled (±30°)	N/A		N/A		2508 mm	99"
B Sweeping width	1524 mm	60"	1829 mm	72"	2119 mm	83"
BB Sweeping width angled (±30°)	N/A		N/A		1849 mm	73"
C Height	872 mm	34"	872 mm	34"	918 mm	36"
D Length without gutter brush	1837 mm	72"	1837 mm	72"	1741 mm	69"
Weight without gutter brush	526 kg	1160 lb	570 kg	1258 lb	401 kg	885 lb
Drive method	Direct drive		Direct drive		Direct drive	
Motor displacement	405 cm <sup>3</sup> /rev	25 in <sup>3</sup> /rev	405 cm <sup>3</sup> /rev	25 in <sup>3</sup> /rev	405 cm <sup>3</sup> /rev	25 in <sup>3</sup> /rev
Optimal hydraulic flow range	42-86 L/min	11-23 gpm	42-86 L/min	11-23 gpm	42-86 L/min	11-23 gpm
Optimal hydraulic pressure range	145-235 bar	2100-3400 psi	145-235 bar	2100-3400 psi	145-235 bar	2100-3400 psi
Brush speed (shaft) @ maximum flow*	199 RPM		199 RPM		199 RPM	
Hopper capacity (struck)**	0.41 m <sup>3</sup>	0.54 yd <sup>3</sup>	0.49 m <sup>3</sup>	0.64 yd <sup>3</sup>	N/A	
	0.41 m <sup>3</sup>	14.6 ft <sup>3</sup>	0.49 m <sup>3</sup>	17.4 ft <sup>3</sup>		
Fasteners	Cat		Cat		Cat	
Hydraulic hose	Cat XT-3 ES		Cat XT-3 ES		Cat XT-3 ES	
Brush diameter	660 mm	26"	660 mm	26"	815 mm	32"
Brush head retention	Dual chain/ loader arm bracket		Dual chain/ loader arm bracket		N/A	
Brush material (standard)	Replaceable polypropylene/ steel wire sections		Replaceable polypropylene/ steel wire sections		Replaceable polypropylene/ steel wire sections	

\*Gutter brush receives 5 gpm maximum flow when installed.

\*\*Rated struck capacities shown as per ISO 7546:1983 and SAE J742 FEB85.

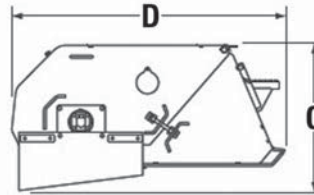
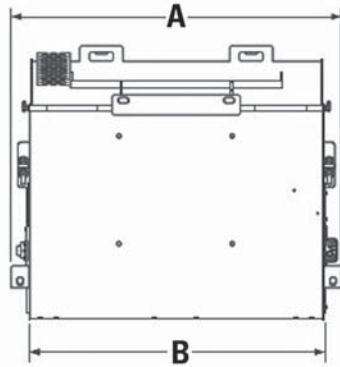

Utility Brooms

MODEL	BU115 Utility Broom		BU118 Utility Broom	
A Overall width	1810 mm	71"	2115 mm	83"
B Sweeping width	1510 mm	59"	1865 mm	73"
C Height	793 mm	31"	793 mm	31"
D Length	1490 mm	59"	1490 mm	59"
Weight	422 kg	930 lb	481 kg	1060 lb
Drive method	Direct drive		Direct drive	
Number of motors	1		1	
Motor displacement	393 cm <sup>3</sup> /rev	24 in <sup>3</sup> /rev	393 cm <sup>3</sup> /rev	24 in <sup>3</sup> /rev
Hydraulic flow range	30-86 L/min	8-23 gpm	30-86 L/min	8-23 gpm
Hydraulic pressure range	145-235 bar	2100-3400 psi	145-235 bar	2100-3400 psi
Rated brush speed @ maximum flow	220 RPM		220 RPM	
Hopper capacity*	0.42 m <sup>3</sup>	0.55 yd <sup>3</sup>	0.49 m <sup>3</sup>	0.64 yd <sup>3</sup>
Fasteners	Cat		Cat	
Hydraulic hose	Cat XT-3 ES		Cat XT-3 ES	
Brush diameter	660 mm	26"	660 mm	26"
Brush material (standard)	Replaceable polypropylene sections		Replaceable polypropylene sections	
Brush material (optional)	Replaceable steel wire sections		Replaceable steel wire sections	

\*Rated struck capacities shown as per ISO 7546:1983 and SAE J742 FEB85.

**Features:**

- **Two direct drive models, the standard flow SG16B and the high flow SG18B** feature a variable speed, unidirectional motor that is matched to the Cat Skid Steer Loader’s auxiliary hydraulic horsepower capabilities. Provides high torque for efficient grinding performance.
- **Heavy-duty 547 mm (21.5") cutting wheel and 32 bolt-on carbide teeth** provide maximum durability and cutting efficiency.
- **Heavy-duty, dual height, pivoting stand feet** provide a stable platform when grinding.
- **Standard hydraulic cutting wheel swing** (full 70 degrees) and extension [280 mm (11 in) max.].
- **Hydraulic depth control on SG18B, depth control on SG16B** is manually adjustable using a 3-position depth control bar.
- **Extension slider rods** are chrome plated for long life.
- **Cat XT-3 and medium pressure hose, couplings and O-Rings.**

**Market Opportunities**

- **Landscaping/Landscaping Maintenance** — Stump grinders are ideal for economically removing tree stumps in residential, commercial and agricultural settings.
- **Rental** — Stump grinders are a high opportunity rental work tool for lawn care and for clean up after natural disasters such as tornadoes and hurricanes where many trees are damaged.

**Stump grinders** are productive work tools for specialized applications. Maneuverability and compact size compared to tow behind stump grinders lend it be to very popular in lawn care and golf course maintenance.

**Machine Compatibility**

Stump Grinder Model	Machine Models
<b>SG16B</b>	216B3, 226B3, 226D, 232D, 236D, 239D, 242D, 246D, 249D, 257D, 259D, 262D, 272D2, 272D2 XHP, 277D, 279D, 287D, 289D, 297D2, 297D2 XHP, 299D2, 299D2 XHP
<b>SG18B*</b>	226B3, 226D, 232D, 236D, 239D, 242D, 246D, 249D, 257D, 259D, 262D, 272D2, 272D2 XHP, 277D, 279D, 287D, 289D, 297D2, 297D2 XHP, 299D2, 299D2 XHP

\*Requires high flow or high flow XPS option on machine.



**Skid Steer Loaders**  
**Multi Terrain Loaders**  
**Compact Track Loaders**

**WorkTools**  
**● Stump Grinders**

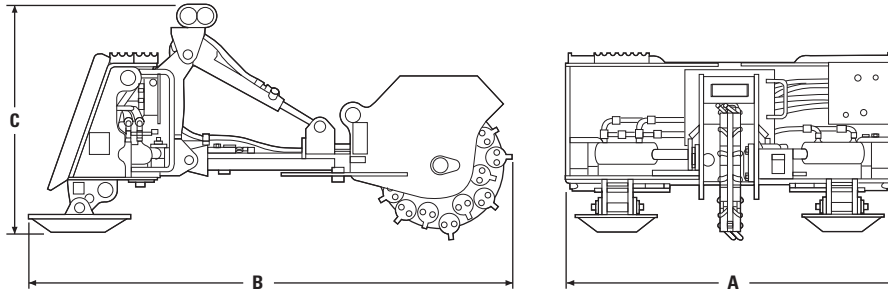

<b>MODEL</b>	<b>SG16B</b>		<b>SG18B</b>	
<b>A</b> Overall width	1175 mm	<b>46"</b>	1175 mm	<b>46"</b>
<b>B</b> Overall length	1737 mm	<b>69"</b>	1737 mm	<b>69"</b>
<b>C</b> Overall height	730 mm	<b>30"</b>	813 mm	<b>32"</b>
Unit weight	379 kg	<b>775 lb</b>	400 kg	<b>840 lb</b>
Drive method	<b>Gerotor Motor – Direct</b>		<b>Gerotor Motor – Direct</b>	
Optimal hydraulic flow	42-86 L/min	<b>11-23 gpm</b>	95-125 L/min	<b>25-33 gpm</b>
Optimal hydraulic pressure	145-235 bar	<b>2100-3400 psi</b>	207-310 bar	<b>3000-4500 psi</b>
Effective displacement	80 cm <sup>3</sup>	<b>4.9 in<sup>3</sup></b>	100 cm <sup>3</sup>	<b>6.2 in<sup>3</sup></b>
Drive shaft torque @ maximum pressure	295 N·m @ 230 bar	<b>218 lb-ft @ 3336 psi</b>	469 N·m @ 290 bar	<b>346 lb-ft @ 4206 psi</b>
Cutting head speed (drive shaft) @ maximum flow	993 RPM @ 80 L/min	<b>993 RPM @ 21 gpm</b>	1280 RPM @ 130 L/min	<b>1280 RPM @ 34 gpm</b>
Cutting wheel width (with teeth)	83 mm	<b>3.3"</b>	83 mm	<b>3.3"</b>
Cutting wheel diameter (with teeth)	547 mm	<b>21.5"</b>	547 mm	<b>21.5"</b>
Cutting width (full swing range)	1524 mm	<b>60"</b>	1524 mm	<b>60"</b>
Cutting head swing range		<b>70°</b>		<b>70°</b>
Cutting height (above ground)	470 mm	<b>18.5"</b>	470 mm	<b>18.5"</b>
Cutting height (below ground)	521 mm	<b>20.5"</b>	521 mm	<b>20.5"</b>
Cutting head extension	280 mm	<b>11"</b>	280 mm	<b>11"</b>
Fasteners	<b>Cat</b>		<b>Cat</b>	
Hydraulic hose	<b>XT-3 ES, medium pressure</b>		<b>XT-6 ES, medium pressure</b>	
Ground Engaging Tools (GET)	<b>12.7 mm (1/2") square bolt-on carbide teeth</b>		<b>12.7 mm (1/2") square bolt-on carbide teeth</b>	
Number of carbide teeth per cutting wheel	<b>32</b>		<b>32</b>	

### SG16B Stump Grinder

Theoretical Drive Shaft Torque			
Pressure		Torque	
bar	psi	N-m	lb-ft
145	2100	186	137
152	2200	194	143
158	2300	204	150
166	2400	212	156
172	2500	222	163
179	2600	230	169
186	2700	239	176
193	2800	248	182
200	2900	257	189
207	3000	265	195
214	3100	275	202
220	3200	283	208
227	3300	292	215

### SG18B Stump Grinder

Theoretical Drive Shaft Torque			
Pressure		Torque	
bar	psi	N-m	lb-ft
207	3000	336	247
214	3100	347	255
221	3200	358	263
227	3300	370	272
234	3400	381	280
241	3500	392	288
248	3600	403	296
255	3700	413	304
262	3800	426	313
269	3900	437	321
276	4000	447	329
282	4100	458	337
289	4200	471	346
296	4300	481	354
303	4400	492	362
310	4500	503	370

### SG16B Stump Grinder

Theoretical Cutting Head Speed (Drive Shaft)		
Flow		Cutting Head Speed
L/min	gpm	RPM
42	11	519
45	12	566
49	13	613
53	14	660
57	15	707
61	16	754
64	17	801
68	18	849
72	19	896
76	20	943
80	21	990
83	22	1037

### SG18B Stump Grinder

Theoretical Cutting Head Speed (Drive Shaft)		
Flow		Cutting Head Speed
L/min	gpm	RPM
95	25	931
99	26	969
102	27	1006
106	28	1043
110	29	1080
114	30	1118
118	31	1155
122	32	1192
125	33	1230

**Skid Steer Loaders  
Multi Terrain Loaders  
Compact Track Loaders**

**WorkTools  
● Angle Blades**

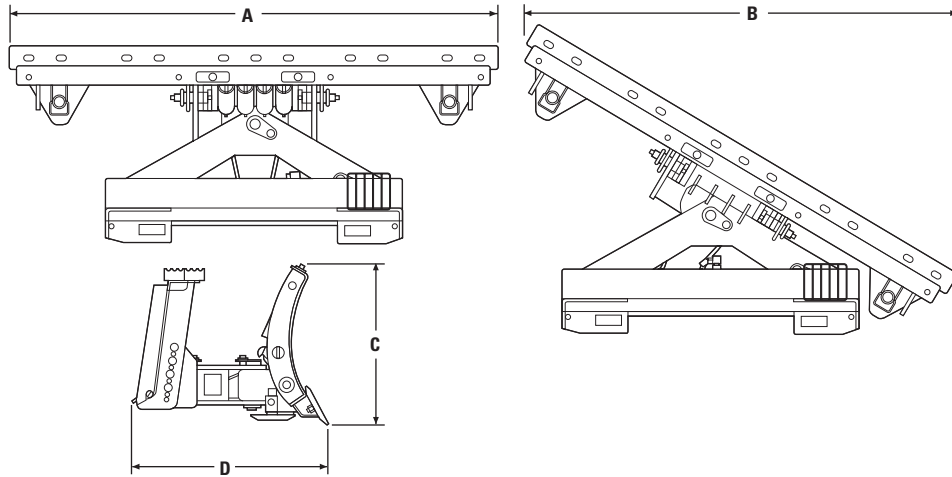

<b>A</b> Overall width (straight)*	1829 mm	<b>72"</b>	2134 mm	<b>84"</b>
<b>B</b> Working width, fully angled	1685 mm	<b>66"</b>	1949 mm	<b>78"</b>
<b>C</b> Height	614 mm	<b>24"</b>	614 mm	<b>24"</b>
<b>D</b> Length	753 mm	<b>30"</b>	753 mm	<b>30"</b>
Weight	313 kg	<b>690 lb</b>	331 kg	<b>730 lb</b>
Adjustable cutting depth (three positions — 25.4 mm (1") increments)	0, 25 and 51 mm	<b>0", 1" and 2"</b>	0, 25 and 51 mm	<b>0", 1" and 2"</b>
Maximum blade angle — (right or left of center)		<b>30°</b>		<b>30°</b>
Maximum blade trip angle		<b>60°</b>		<b>60°</b>

\*Measured from moldboard edges; overall width is approximately 50 mm (2") wider with bolt-on edge.

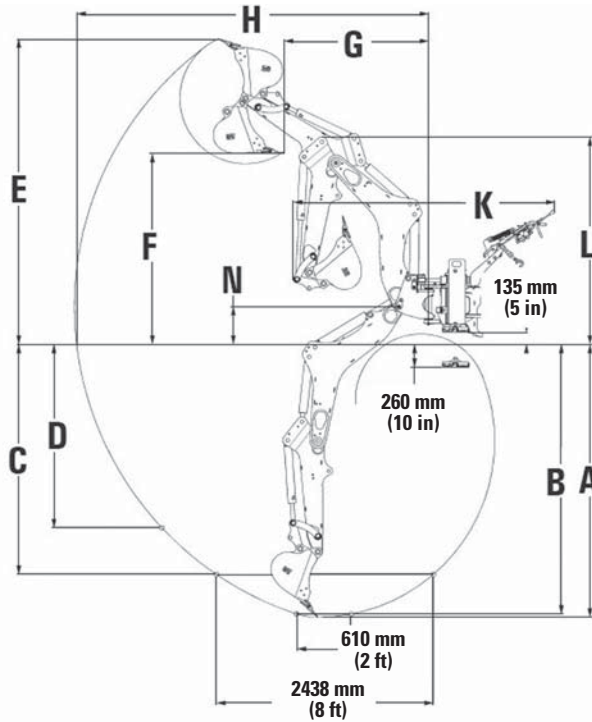

MODEL	BH150		BH160	
<b>Operational Specifications</b>				
A Digging depth maximum	3074 mm	121"	3074 mm	121"
B Digging depth 0.61 m (2') flat bottom	3040 mm	120"	3040 mm	120"
C Digging depth 2.44 m (8') flat bottom	2593 mm	102"	2593 mm	102"
D Straight wall digging depth	2064 mm	81"	2064 mm	81"
E Overall operating height	3442 mm	136"	3442 mm	136"
F Loading height	2147 mm	85"	2147 mm	85"
G Loading reach	1628 mm	64"	1628 mm	64"
H Reach from swing pivot	3955 mm	156"	3955 mm	156"
K Overall length	2776 mm	109"	2936 mm	116"
Side shift travel	742 mm	29"	894 mm	35"
Swing arc	180°		180°	
Bucket rotation	192°		192°	
Bucket breakout force	3241 kg	7146 lb	3241 kg	7146 lb
Stick breakout force	1560 kg	3439 lb	1560 kg	3439 lb
<b>Transport Dimensions</b>				
L Transport height	2336 mm	92"	2336 mm	92"
N Boom pivot height	425 mm	17"	425 mm	17"
Ground clearance	85.7 mm	3.4"	85.7 mm	3.4"
Operating weight	1023 kg	2256 lb	1047 kg	2309 lb

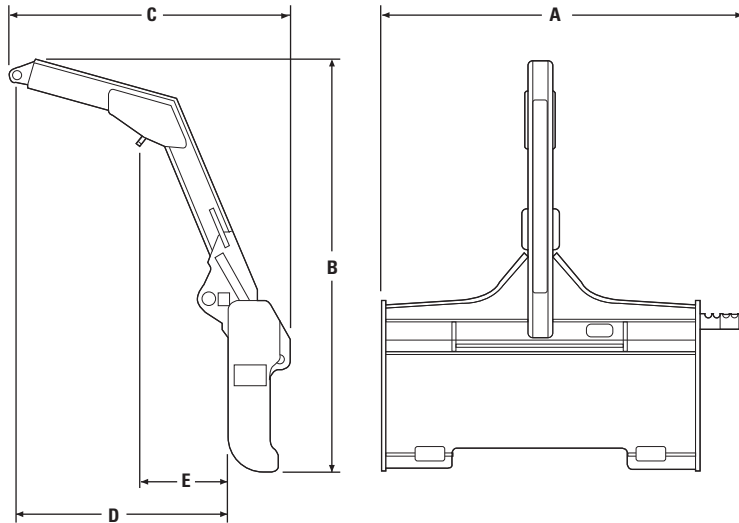

<b>A</b> Width with side step	1309 mm	<b>52"</b>
<b>B</b> Height	1473 mm	<b>58"</b>
<b>C</b> Length	1016 mm	<b>40"</b>
<b>D</b> Load length (end point)	768 mm	<b>30"</b>
<b>E</b> Load length (mid point)	311 mm	<b>12"</b>
Rated structural capacity*	907 kg	<b>2000 lb</b>
Maximum reach (horizontal)**	2134 mm	<b>84"</b>
Weight	127 kg	<b>280 lb</b>

\*Rated structural capacity is the maximum load that can be carried by the work tool and does not imply that the specific host machine has the tipping capacity to lift the load. Refer to the Cat Skid Steer Loader and Multi Terrain Loader Operation and Maintenance Manual (OMM) for Cat Skid Steer Loader and Multi Terrain Loader rated operating capacity with Material Handling Arm.

\*\*Maximum horizontal reach is measured from the front tire with the loader arms approximately 1.5 m (5') off the ground and work tool tilted forward approximately 68 degrees at the end point.

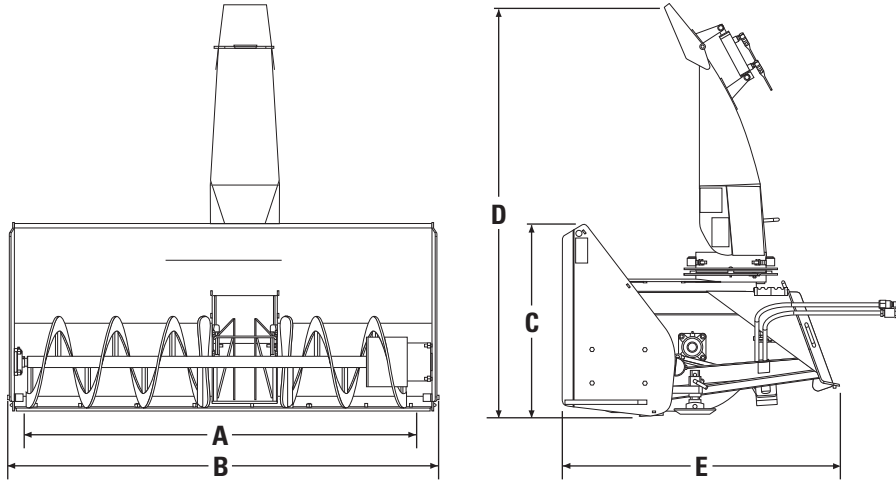

MODEL	SR117		SR118		SR121	
A Intake width	1702 mm	67"	1854 mm	73"	2159 mm	85"
B Overall width	1765 mm	69.5"	1918 mm	75.5"	2223 mm	87.5"
C Cutting height	610 mm	24"	826 mm	33"	883 mm	35"
D Overall height	1797 mm	71"	1797 mm	71"	1797 mm	71"
E Overall length	1148 mm	45.2"	1209 mm	47.6"	1440 mm	56.7"
Weight	419 kg	924 lb	474 kg	1045 lb	591 kg	1303 lb
Maximum throw distance*	9.1 m	30'0"	12.2 m	40'0"	12.2 m	40'0"
Auger diameter	305 mm	12"	406 mm	16"	457 mm	18"
Impeller/fan diameter	517 mm	20"	517 mm	20"	679 mm	27"
Chute rotation	180°		180°		180°	
Optimal hydraulic flow	53-75 L/min	14-20 gpm	68-83 L/min	18-22 gpm	68-87 L/min	18-23 gpm

MODEL	SR318		SR321	
A Intake width	1854 mm	73"	2159 mm	85"
B Overall width	1918 mm	75.5"	2223 mm	87.5"
C Cutting height	826 mm	33"	883 mm	35"
D Overall height	1957 mm	77"	1957 mm	77"
E Overall length	1209 mm	47.6"	1440 mm	56.7"
Weight	475 kg	1047 lb	592 kg	1305 lb
Maximum throw distance*	13.7 m	45'0"	13.7 m	45'0"
Auger diameter	406 mm	16"	457 mm	18"
Impeller/fan diameter	517 mm	20"	679 mm	27"
Chute rotation	180°		180°	
Optimal hydraulic flow	98-130 L/min	26-34 gpm	98-130 L/min	26-34 gpm

\*Theoretical values calculated at 100% efficiency.

**Skid Steer Loaders  
Multi Terrain Loaders  
Compact Track Loaders**

**WorkTools  
● Wheel Saws**

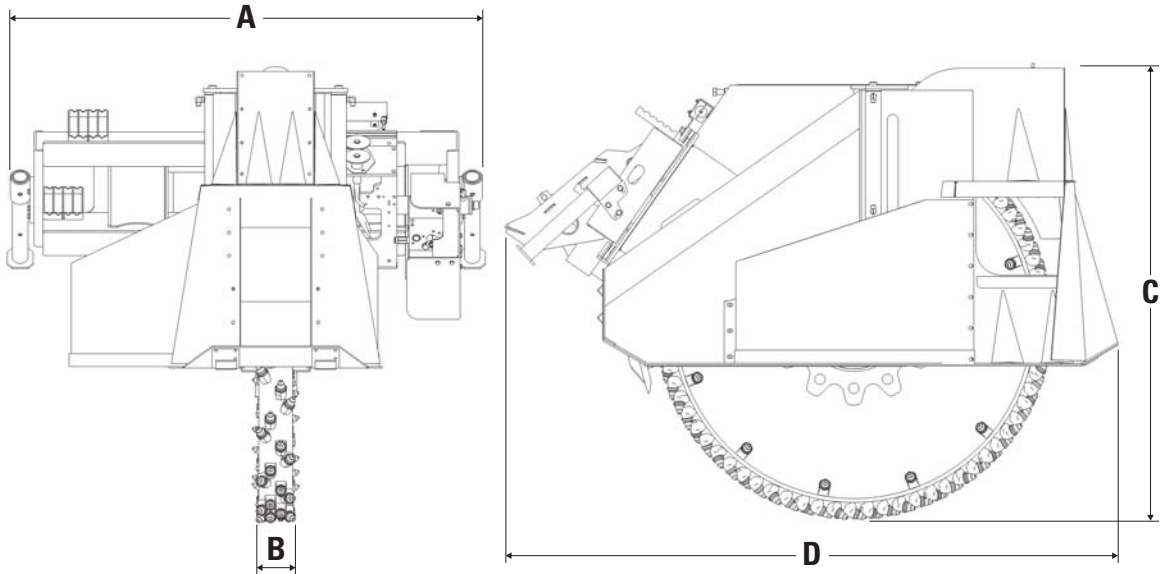

<b>MODEL</b>	<b>SW345B 80 mm (3")</b>		<b>SW360B 80 mm (3")</b>		<b>SW360B 160 mm (6")</b>	
<b>A Overall width</b>	1850 mm	<b>73"</b>	1850 mm	<b>73"</b>	1850 mm	<b>73"</b>
<b>B Wheel width</b>	80 mm	<b>3"</b>	80 mm	<b>3"</b>	160 mm	<b>6"</b>
<b>C Overall height</b>	1455 mm	<b>57"</b>	1765 mm	<b>70"</b>	1765 mm	<b>70"</b>
<b>D Length</b>	2165 mm	<b>85"</b>	2365 mm	<b>93"</b>	2365 mm	<b>93"</b>
Weight	1156 kg	<b>2549 lb</b>	1470 kg	<b>3240 lb</b>	1365 kg	<b>3009 lb</b>
Trench cleaning device	<b>No</b>		<b>No</b>		<b>Yes</b>	
Drive method	<b>Piston motor</b>		<b>Piston motor</b>		<b>Piston motor</b>	
Optimal hydraulic flow	125 L/min	<b>33 gpm</b>	125 L/min	<b>33 gpm</b>	125 L/min	<b>33 gpm</b>
Optimal hydraulic pressure	280 bar	<b>4065 psi</b>	280 bar	<b>4065 psi</b>	280 bar	<b>4065 psi</b>
Wheel torque @ maximum pressure	6244 N·m	<b>4604 lb-ft</b>	7509 N·m	<b>5538 lb-ft</b>	7509 N·m	<b>5538 lb-ft</b>
Wheel speed @ maximum flow	<b>89 RPM</b>		<b>74 RPM</b>		<b>74 RPM</b>	
Bit speed @ maximum flow	349 m/min	<b>1143 ft/min</b>	360 m/min	<b>1180 ft/min</b>	360 m/min	<b>1180 ft/min</b>
Conical bits	<b>64 per wheel</b>		<b>70 per wheel</b>		<b>96 per wheel</b>	
Standard bit type	<b>Concrete</b>		<b>Concrete</b>		<b>Concrete</b>	
Optional bit type	<b>All purpose</b>		<b>All purpose</b>		<b>All purpose</b>	
Maximum depth of cut	450 mm	<b>18"</b>	600 mm	<b>24"</b>	600 mm	<b>24"</b>
Sideshift travel	550 mm	<b>22"</b>	550 mm	<b>22"</b>	550 mm	<b>22"</b>

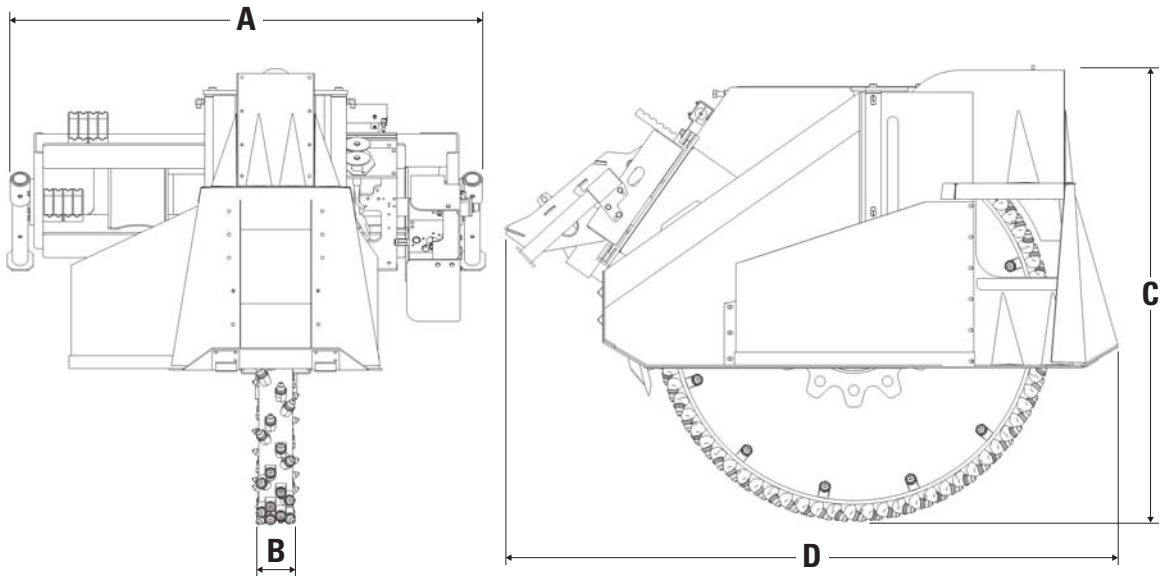

MODEL	SW360B 200 mm (8")		SW380B 250 mm (10")		SW460B 80 mm (3")	
A Overall width	1850 mm	73"	1850 mm	73"	1850 mm	73"
B Wheel width	200 mm	8"	250 mm	10"	80 mm	3"
C Overall height	1765 mm	70"	1950 mm	77"	1765 mm	70"
D Length	2365 mm	93"	2490 mm	98"	2365 mm	93"
Weight	1395 kg	3075 lb	1440 kg	3175 lb	1470 kg	3240 lb
Trench cleaning device	Yes		No		No	
Drive method	Piston motor		Piston motor		Piston motor	
Optimal hydraulic flow	125 L/min	33 gpm	125 L/min	33 gpm	150 L/min	40 gpm
Optimal hydraulic pressure	280 bar	4065 psi	280 bar	4065 psi	280 bar	4065 psi
Wheel torque @ maximum pressure	7509 N·m	5538 lb-ft	7509 N·m	5538 lb-ft	7509 N·m	5538 lb-ft
Wheel speed @ maximum flow	74 RPM		74 RPM		89 RPM	
Bit speed @ maximum flow	360 m/min	1180 ft/min	372 m/min	1228 ft/min	430 m/min	1420 ft/min
Conical bits	96 per wheel		72 per wheel		70 per wheel	
Standard bit type	Concrete		Concrete		Concrete	
Optional bit type	All purpose		All purpose		All purpose	
Maximum depth of cut	600 mm	24"	800 mm	32"	600 mm	24"
Sideshift travel	550 mm	22"	550 mm	22"	550 mm	22"



**Skid Steer Loaders  
Multi Terrain Loaders  
Compact Track Loaders**

**WorkTools  
● Wheel Saws**

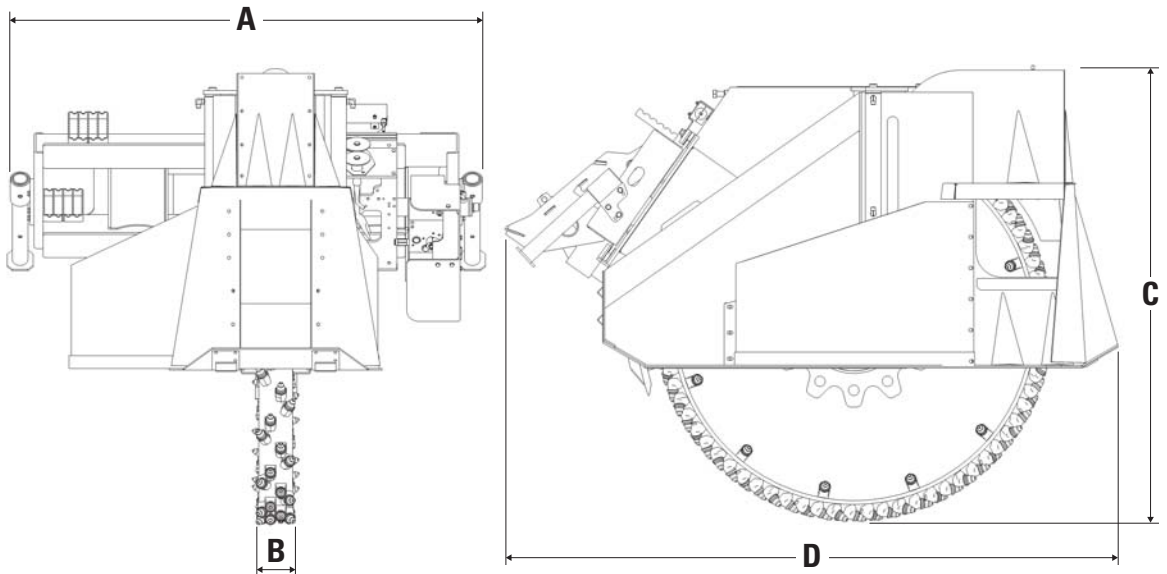

<b>MODEL</b>	<b>SW460B 160 mm (6")</b>		<b>SW460B 200 mm (8")</b>		<b>SW480B 200 mm (8")</b>	
<b>A Overall width</b>	1850 mm	<b>73"</b>	1850 mm	<b>73"</b>	1850 mm	<b>73"</b>
<b>B Wheel width</b>	160 mm	<b>6"</b>	200 mm	<b>8"</b>	250 mm	<b>10"</b>
<b>C Overall height</b>	1765 mm	<b>70"</b>	1765 mm	<b>70"</b>	1950 mm	<b>77"</b>
<b>D Length</b>	2365 mm	<b>93"</b>	2365 mm	<b>93"</b>	2490 mm	<b>98"</b>
Weight	1365 kg	<b>3009 lb</b>	1395 kg	<b>3075 lb</b>	1440 kg	<b>3175 lb</b>
Trench cleaning device	<b>Yes</b>		<b>Yes</b>		<b>No</b>	
Drive method	<b>Piston motor</b>		<b>Piston motor</b>		<b>Piston motor</b>	
Optimal hydraulic flow	150 L/min	<b>40 gpm</b>	150 L/min	<b>40 gpm</b>	150 L/min	<b>40 gpm</b>
Optimal hydraulic pressure	280 bar	<b>4065 psi</b>	280 bar	<b>4065 psi</b>	280 bar	<b>4065 psi</b>
Wheel torque @ maximum pressure	7509 N·m	<b>5538 lb-ft</b>	7509 N·m	<b>5538 lb-ft</b>	7509 N·m	<b>5538 lb-ft</b>
Wheel speed @ maximum flow	<b>89 RPM</b>		<b>89 RPM</b>		<b>89 RPM</b>	
Bit speed @ maximum flow	430 m/min	<b>1420 ft/min</b>	430 m/min	<b>1420 ft/min</b>	447 m/min	<b>1476 ft/min</b>
Conical bits	<b>96 per wheel</b>		<b>96 per wheel</b>		<b>72 per wheel</b>	
Standard bit type	<b>Concrete</b>		<b>Concrete</b>		<b>Concrete</b>	
Optional bit type	<b>All purpose</b>		<b>All purpose</b>		<b>All purpose</b>	
Maximum depth of cut	600 mm	<b>24"</b>	600 mm	<b>24"</b>	800 mm	<b>32"</b>
Sideshift travel	550 mm	<b>22"</b>	550 mm	<b>22"</b>	550 mm	<b>22"</b>

# SURFACE MINING EXTRACTION

## Draglines

### Electric Rope Shovels

### Hydraulic Mining Shovels

#### CONTENTS

##### DRAGLINES

Introduction . . . . .	16-3
Safety and Serviceability . . . . .	16-3
Features . . . . .	16-4
8000	
Specifications . . . . .	16-5
Dimensions/Working Ranges . . . . .	16-6
8200	
Specifications . . . . .	16-7
Dimensions/Working Ranges . . . . .	16-8
8750 – 22.9 m (75 ft) Base	
Specifications . . . . .	16-9
Dimensions/Working Ranges . . . . .	16-12
8750 – 25.6 m (84 ft) Base	
Specifications . . . . .	16-15
Dimensions/Working Ranges . . . . .	16-19
10/10/20 Load Management Policy . . . . .	16-23

##### ELECTRIC ROPE SHOVELS

Introduction . . . . .	16-25
Safety and Serviceability . . . . .	16-25
Features . . . . .	16-25
Specifications . . . . .	16-28
Digging Envelopes . . . . .	16-31
General Dimensions . . . . .	16-38
Ground Bearing Pressure . . . . .	16-45
Dipper Selection . . . . .	16-46
Truck Match . . . . .	16-47
Rated Suspended Load . . . . .	16-47
10/10/20 Load Management Policy . . . . .	16-48

Throughout this document, references to Tier 4 Interim/Stage IIIB/Japan 2011 (Tier 4 Interim) include U.S. EPA Tier 4 Interim, EU Stage IIIB, and Japan 2011 (Tier 4 Interim) equivalent emission standards. References to Tier 4 Final/Stage IV/Japan 2014 (Tier 4 Final) include U.S. EPA Tier 4 Final, EU Stage IV, and Japan 2014 (Tier 4 Final) emission standards.

Throughout this document, references to Tier 1/Stage I include U.S. EPA Tier 1 and EU Stage I equivalent emission standards. References to Tier 2/Stage II/Japan 2001 (Tier 2) equivalent include U.S. EPA Tier 2, EU Stage II, and Japan 2001 (Tier 2) equivalent emission standards. References to Tier 3/Stage IIIA/Japan 2006 (Tier 3) equivalent include U.S. EPA Tier 3, EU Stage IIIA, and Japan 2006 (Tier 3) equivalent emission standards.

**HYDRAULIC MINING SHOVELS**

- General Introduction..... 16-49
- Features ..... 16-50
- Specifications..... 16-51
- Digging Envelopes/Working Range/  
Digging Forces..... 16-60
- General Dimensions ..... 16-71
- Ground Pressures ..... 16-76
- Bucket Selection ..... 16-79
- Cycle Times ..... 16-80
- Production Overviews..... 16-82

# DRAGLINES

## CONTENTS

### DRAGLINES

Introduction . . . . .	16-3
Safety and Serviceability . . . . .	16-3
Features . . . . .	16-4
8000	
Specifications . . . . .	16-5
Dimensions/Working Ranges . . . . .	16-6
8200	
Specifications . . . . .	16-7
Dimensions/Working Ranges . . . . .	16-8
8750 – 22.9 m (75 ft) Base	
Specifications . . . . .	16-9
Dimensions/Working Ranges . . . . .	16-12
8750 – 25.6 m (84 ft) Base	
Specifications . . . . .	16-15
Dimensions/Working Ranges . . . . .	16-19
10/10/20 Load Management Policy . . . . .	16-23

## INTRODUCTION

Draglines are an important excavating tool used in many surface mining operations worldwide. These highly productive machines operate 24 hours a day, seven days a week and are able to reach depths of 79.8 m (262 ft) with capacities up to 116.2 m<sup>3</sup> (152 yd<sup>3</sup>). Offering the lowest material removal cost per tonne (ton) and an average operating life of 40 years, draglines are the most productive and versatile machine in the industry. Caterpillar offers an extensive variety of dragline specifications and on-staff application engineers who will help determine the solution that best addresses specific needs.

With over 100 years of dragline experience and the largest operating fleet of draglines with buckets of 40 m<sup>3</sup> (52.3 yd<sup>3</sup>) and above, coupled with an active installed base of over 300 machines, Cat draglines are the most efficient and proven overburden removal solution.

## SAFETY AND SERVICEABILITY

Safety plays an integral role in everything we do at Caterpillar, from our factory floors to our service centers to our clients' mine sites. Caterpillar's commitment to safety is apparent in our product designs, which undergo risk assessments and are designed to meet strict codes and regulations. Stairways, walkways, platforms and access points are incorporated throughout Cat<sup>®</sup> draglines to ensure safe and convenient access for maintenance personnel. With safety and serviceability enhancing features incorporated into the operator cab, structures, surfaces and electrical equipment, among others, Cat draglines were designed with safety in mind.

## FEATURES

### AC IGBT Electrics

Cat draglines are equipped with AC IGBT electrics which allow for greater machine uptime, lower operating costs, and faster cycle times, with AC providing up to 10% energy savings over the life of the machine.

- **Superior availability:** AC IGBT electric draglines have routinely demonstrated electrical availabilities of greater than 95%.
- **Greater reliability:** Fewer components including interchangeable inverters. IGBT systems require no fuses or circuit breakers.
- **Reduced maintenance:** No regular maintenance is required on IGBT power control modules. Motor maintenance on AC machines is reduced to greasing and replacing bearings every 30,000 hours.
- **Reduced inventory:** Hoist, drag, swing, and propel motions are all controlled by AC motors. Cat IGBT is a mine quality system with rugged welded cabinets to withstand harsh mining conditions.

### Major Structures

Cat major structures are designed for extended performance in harsh mining conditions. Structures are manufactured using impact-resistant, high-strength steel with select welds of full-penetration, profiled and ground type. All structural welds undergo visual inspection, with critical welds also receiving MT, UT or X-ray inspection. Large furnaces are used to stress-relieve entire weldments for reduced susceptibility to cracking. Interiors of finished structures are painted white to facilitate field inspection.

### Tri-Structure Design

The exclusive tri-structure design on Cat draglines reduces front end weight to enable optimization of boom configurations, allowing for increased load and reach. The tri-structure is manufactured with high impact strength steel for a simplified wide flange beam construction, and less maintenance points are required in comparison with an A-frame or mast assembly. Inventory stocking needs are reduced as the sheaves are interchangeable with both the fairlead and boom assemblies.

### Cat Cab

Cat's state-of-the-art operator's cab is the product of a multi-year collaboration between Caterpillar, mining companies and operators. The cab provides industry-leading visibility with excellent line of sight supplemented by five optimally-mounted cameras and display screens. It provides enhanced safety through dual access/egress doors and an optimally-placed trainer seat with independent emergency stop. Additionally, the cab offers the smoothest, most comfortable ride available with an ergonomic, adjustable operator's seat with a fully pneumatic suspension system, low-effort joysticks and dual display screens optimized for operator comfort.

### Custom Design and Aftermarket Support

The Cat dragline model selection process is grounded in analysis and collaboration with experienced application engineering professionals and a dragline optimization process to assist in determining the configuration optimally suited for a particular application. Additionally, mechanical and electrical upgrades, and component rebuilds are available to ensure productivity and reliability for the life of the machine. Caterpillar also offers machine relocation and field assembly services supported by experienced industry experts.

MODEL	8000					
Boom Length	76.2 m	<b>250'0"</b>	93.0 m	<b>305'0"</b>	96.0 m	<b>315'0"</b>
Boom Angle	<b>32°</b>		<b>38°</b>		<b>33°</b>	
Rated Suspension Load	95 254 kg	<b>210,000 lb</b>	92 986 kg	<b>205,000 lb</b>	79 379 kg	<b>175,000 lb</b>
Weights*						
Net Weight, Domestic (approximate with bucket)	1 469 639 kg	<b>3,240,000 lb</b>	1 542 214 kg	<b>3,400,000 lb</b>	1 610 253 kg	<b>3,550,000 lb</b>
Working Weight (approximate with bucket)	1 769 010 kg	<b>3,900,000 lb</b>	1 927 768 kg	<b>4,250,000 lb</b>	1 995 806 kg	<b>4,400,000 lb</b>
Ballast Weight (approximate)	299 371 kg	<b>660,000 lb</b>	385 554 kg	<b>850,000 lb</b>	385 554 kg	<b>850,000 lb</b>
Drag Rope						
Drum Diameter	243.8 cm	<b>96"</b>	243.8 cm	<b>96"</b>	243.8 cm	<b>96"</b>
Number	<b>2</b>		<b>2</b>		<b>2</b>	
Rope Diameter	6.99 cm	<b>2.75"</b>	6.99 cm	<b>2.75"</b>	6.99 cm	<b>2.75"</b>
Hoist Rope						
Drum Diameter	243.8 cm	<b>96"</b>	243.8 cm	<b>96"</b>	243.8 cm	<b>96"</b>
Number	<b>2</b>		<b>2</b>		<b>2</b>	
Rope Diameter	6.99 cm	<b>2.75"</b>	6.99 cm	<b>2.75"</b>	6.99 cm	<b>2.75"</b>
Electrical						
IGBT-AFE Inverter Cabinets	<b>(2) water cooled</b>		<b>(2) water cooled</b>		<b>(2) water cooled</b>	
Hoist Motors	(2) × 1230 kW	<b>(2) × 1650 hp</b>	(2) × 1230 kW	<b>(2) × 1650 hp</b>	(2) × 1230 kW	<b>(2) × 1650 hp</b>
Drag Motors	(2) × 1230 kW	<b>(2) × 1650 hp</b>	(2) × 1230 kW	<b>(2) × 1650 hp</b>	(2) × 1230 kW	<b>(2) × 1650 hp</b>
Swing Motors	(2) × 932 kW	<b>(2) × 1250 hp</b>	(2) × 932 kW	<b>(2) × 1250 hp</b>	(2) × 932 kW	<b>(2) × 1250 hp</b>
Walking Motors	<b>Common shaft clutched off one drag motor</b>		<b>Common shaft clutched off one drag motor</b>		<b>Common shaft clutched off one drag motor</b>	
Base						
Outside Diameter	15.5 m	<b>51'0"</b>	15.5 m	<b>51'0"</b>	15.5 m	<b>51'0"</b>
Bearing Area	189.8 m <sup>2</sup>	<b>2043 ft<sup>2</sup></b>	189.8 m <sup>2</sup>	<b>2043 ft<sup>2</sup></b>	189.8 m <sup>2</sup>	<b>2043 ft<sup>2</sup></b>
Bearing Pressure*	91.4 kPa	<b>13.3 psi</b>	91.6 kPa	<b>14.4 psi</b>	103.1 kPa	<b>15.0 psi</b>
Circle Rail Diameter	15.2 m	<b>50'0"</b>	15.2 m	<b>50'0"</b>	15.2 m	<b>50'0"</b>
Rollers (average diameter)	26 cm	<b>10.25"</b>	26 cm	<b>10.25"</b>	26 cm	<b>10.25"</b>
Swing Gear (pitch diameter)	12.9 m	<b>42'5"</b>	12.9 m	<b>42'5"</b>	12.9 m	<b>42'5"</b>
Walking Mounting						
Shoe Width and Length	2.7 m × 16.8 m	<b>9'0" × 55'0"</b>	2.7 m × 16.8 m	<b>9'0" × 55'0"</b>	2.7 m × 16.8 m	<b>9'0" × 55'0"</b>
Combined Bearing Area	92 m <sup>2</sup>	<b>990 ft<sup>2</sup></b>	92 m <sup>2</sup>	<b>990 ft<sup>2</sup></b>	92 m <sup>2</sup>	<b>990 ft<sup>2</sup></b>
Bearing Pressure (@ 80% working weight)	150.9 kPa	<b>21.9 psi</b>	164.4 kPa	<b>23.8 psi</b>	170.2 kPa	<b>24.7 psi</b>
Overall Width over Shoes	21.6 m	<b>71'0"</b>	21.6 m	<b>71'0"</b>	21.6 m	<b>71'0"</b>
Length of Step (approximate)	2.13 m	<b>7'0"</b>	2.13 m	<b>7'0"</b>	2.13 m	<b>7'0"</b>
Bucket Capacity	32 m <sup>3</sup>	<b>42 yd<sup>3</sup></b>	31 m <sup>3</sup>	<b>41 yd<sup>3</sup></b>	27 m <sup>3</sup>	<b>35 yd<sup>3</sup></b>

\*Net weight, ballast weight, working weight, bearing pressure (kPa/psi) will vary with boom length, angle, and rated suspended load.  
NOTE: The 93 m (305'0") and 96 m (315'0") boom options have a mast.

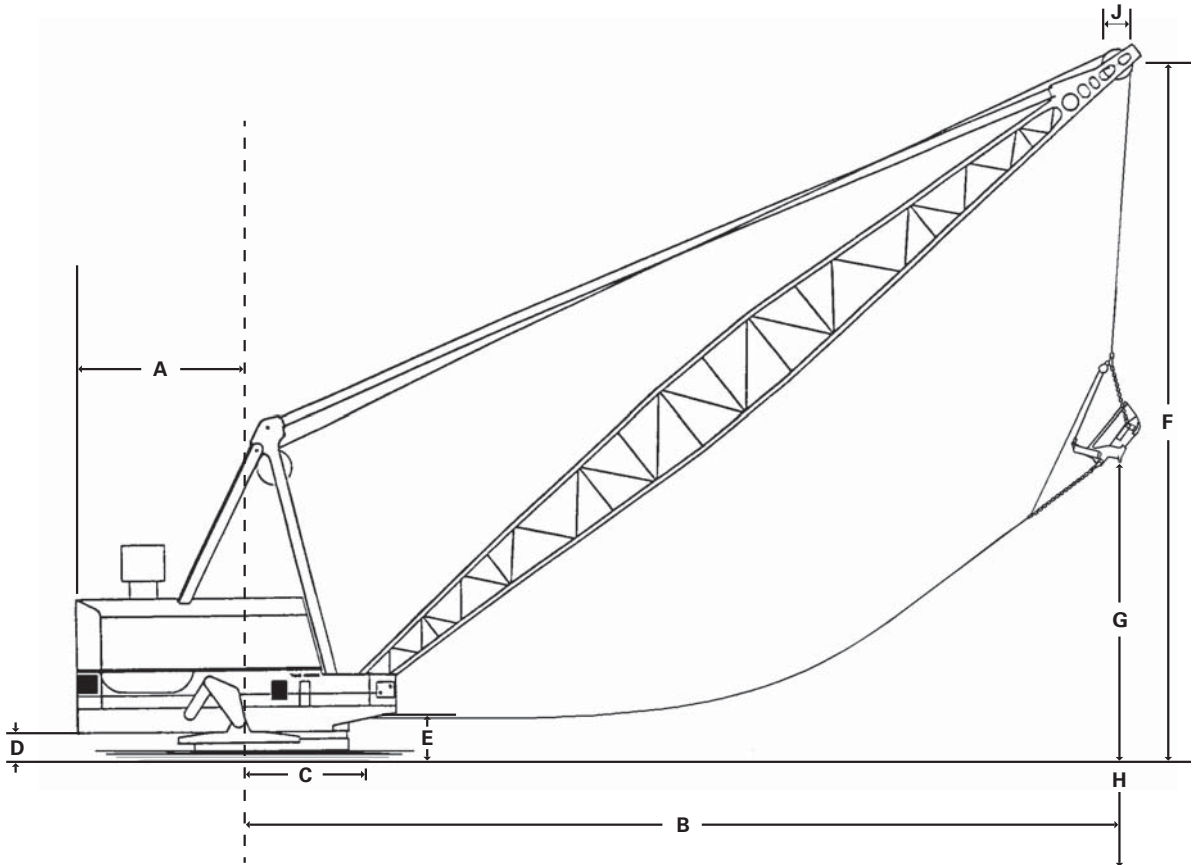

**MODEL**

**8000**

	76.2 m	250'0"	93.0 m	305'0"	96.0 m	315'0"
<b>Boom Length</b>	76.2 m	250'0"	93.0 m	305'0"	96.0 m	315'0"
<b>Boom Angle</b>	32°		38°		33°	
<b>Rated Suspension Load</b>	95 254 kg	210,000 lb	92 986 kg	205,000 lb	79 379 kg	175,000 lb
<b>Dimensions/Working Ranges</b>						
<b>A</b> Clearance Radius	16.8 m	55'3"	16.8 m	55'3"	16.8 m	55'3"
<b>B</b> Operating Radius	71.9 m	236'0"	79.9 m	262'0"	88.1 m	289'0"
<b>C</b> Boom Foot Radius	6.2 m	20'3"	6.2 m	20'3"	6.2 m	20'3"
<b>D</b> Clearance Height	1.8 m	5'9"	1.8 m	5'9"	1.8 m	5'9"
<b>E</b> Boom Foot Height	4.1 m	13'6"	4.1 m	13'6"	4.1 m	13'6"
<b>F</b> Boom Point Height	44.5 m	146'0"	62.2 m	204'0"	56.0 m	183'8"
<b>G</b> Dumping Height	32.3 m	106'0"	50.0 m	164'0"	44.2 m	145'0"
<b>H</b> Digging Depth	62.2 m	204'0"	44.5 m	146'0"	50.3 m	165'0"
<b>J</b> Point Sheave Pitch Diameter	228.6 cm	90"	228.6 cm	90"	228.6 cm	90"

NOTE: The 93 m (305'0") and 96 m (315'0") boom options have a mast.

MODEL	8200											
	100 m		328'0"		100 m		328'0"		100 m		328'0"	
Boom Length												
Boom Angle	39°		35°		32°							
Rated Suspension Load	181 437 kg	<b>400,000 lb</b>	181 437 kg	<b>400,000 lb</b>	172 365 kg	<b>380,000 lb</b>						
Weights*												
Net Weight, Domestic (approximate with bucket)	3 492 661 kg	<b>7,700,000 lb</b>	3 492 661 kg	<b>7,700,000 lb</b>	3 488 125 kg	<b>7,690,000 lb</b>						
Working Weight (approximate with bucket)	4 123 155 kg	<b>9,090,000 lb</b>	4 173 050 kg	<b>9,200,000 lb</b>	4 139 938 kg	<b>9,127,000 lb</b>						
Ballast Weight (approximate)	630 493 kg	<b>1,390,000 lb</b>	680 389 kg	<b>1,500,000 lb</b>	651 812 kg	<b>1,437,000 lb</b>						
Drag Rope												
Drum Diameter	254 cm	<b>100"</b>	254 cm	<b>100"</b>	254 cm	<b>100"</b>						
Number	2		2		2							
Rope Diameter	9.525 cm	<b>3.750"</b>	9.525 cm	<b>3.750"</b>	9.525 cm	<b>3.750"</b>						
Hoist Rope												
Drum Diameter	254 cm	<b>100"</b>	254 cm	<b>100"</b>	254 cm	<b>100"</b>						
Number	2		2		2							
Rope Diameter	9.525 cm	<b>3.750"</b>	9.525 cm	<b>3.750"</b>	9.525 cm	<b>3.750"</b>						
Electrical												
IGBT-AFE Inverter Cabinets	<b>(2) water cooled</b>		<b>(2) water cooled</b>		<b>(2) water cooled</b>							
Hoist Motors	(4) × 1230 kW	<b>(4) × 1650 applied hp</b>	(4) × 1230 kW	<b>(4) × 1650 applied hp</b>	(4) × 1230 kW	<b>(4) × 1650 applied hp</b>						
Drag Motors	(4) × 1230 kW	<b>(4) × 1650 applied hp</b>	(4) × 1230 kW	<b>(4) × 1650 applied hp</b>	(4) × 1230 kW	<b>(4) × 1650 applied hp</b>						
Swing Motors	(4) × 932 kW	<b>(4) × 1250 applied hp</b>	(4) × 932 kW	<b>(4) × 1250 applied hp</b>	(4) × 932 kW	<b>(4) × 1250 applied hp</b>						
Walking Motors	(2) × 932 kW	<b>(2) × 1250 applied hp</b>	(2) × 932 kW	<b>(2) × 1250 applied hp</b>	(2) × 932 kW	<b>(2) × 1250 applied hp</b>						
Base												
Outside Diameter	19.5 m	<b>64'0"</b>	19.5 m	<b>64'0"</b>	19.5 m	<b>64'0"</b>						
Bearing Area	298.9 m <sup>2</sup>	<b>3217 ft<sup>2</sup></b>	298.9 m <sup>2</sup>	<b>3217 ft<sup>2</sup></b>	298.9 m <sup>2</sup>	<b>3217 ft<sup>2</sup></b>						
Bearing Pressure*	135.1 kPa	<b>19.6 psi</b>	136.5 kPa	<b>19.8 psi</b>	135.8 kPa	<b>19.7 psi</b>						
Circle Rail Diameter	15.2 m	<b>50'0"</b>	15.2 m	<b>50'0"</b>	15.2 m	<b>50'0"</b>						
Rollers (average diameter)	30.5 cm	<b>12"</b>	30.5 cm	<b>12"</b>	30.5 cm	<b>12"</b>						
Swing Gear (pitch diameter)	130.3 m	<b>42'9"</b>	130.3 m	<b>42'9"</b>	130.3 m	<b>42'9"</b>						
Walking Mounting												
Shoe Width and Length	3.9 m × 19.8 m	<b>13'0" × 65'0"</b>	3.9 m × 19.8 m	<b>13'0" × 65'0"</b>	3.9 m × 19.8 m	<b>13'0" × 65'0"</b>						
Combined Bearing Area	157 m <sup>2</sup>	<b>1690 ft<sup>2</sup></b>	157 m <sup>2</sup>	<b>1690 ft<sup>2</sup></b>	157 m <sup>2</sup>	<b>1690 ft<sup>2</sup></b>						
Bearing Pressure (@ 80% of working weight)	206.2 kPa	<b>29.9 psi</b>	208.2 kPa	<b>30.2 psi</b>	206.8 kPa	<b>30.0 psi</b>						
Overall Width over Shoes	29.5 m	<b>97'0"</b>	29.5 m	<b>97'0"</b>	29.5 m	<b>97'0"</b>						
Length of Step (approximate)	2.26 m	<b>7'5"</b>	2.26 m	<b>7'5"</b>	2.26 m	<b>7'5"</b>						
Bucket Capacity	61 m <sup>3</sup>	<b>80 yd<sup>3</sup></b>	61 m <sup>3</sup>	<b>80 yd<sup>3</sup></b>	58 m <sup>3</sup>	<b>76 yd<sup>3</sup></b>						

\*Net weight, ballast weight, working weight, bearing pressure (kPa/psi) will vary with boom length, angle, and rated suspended load.



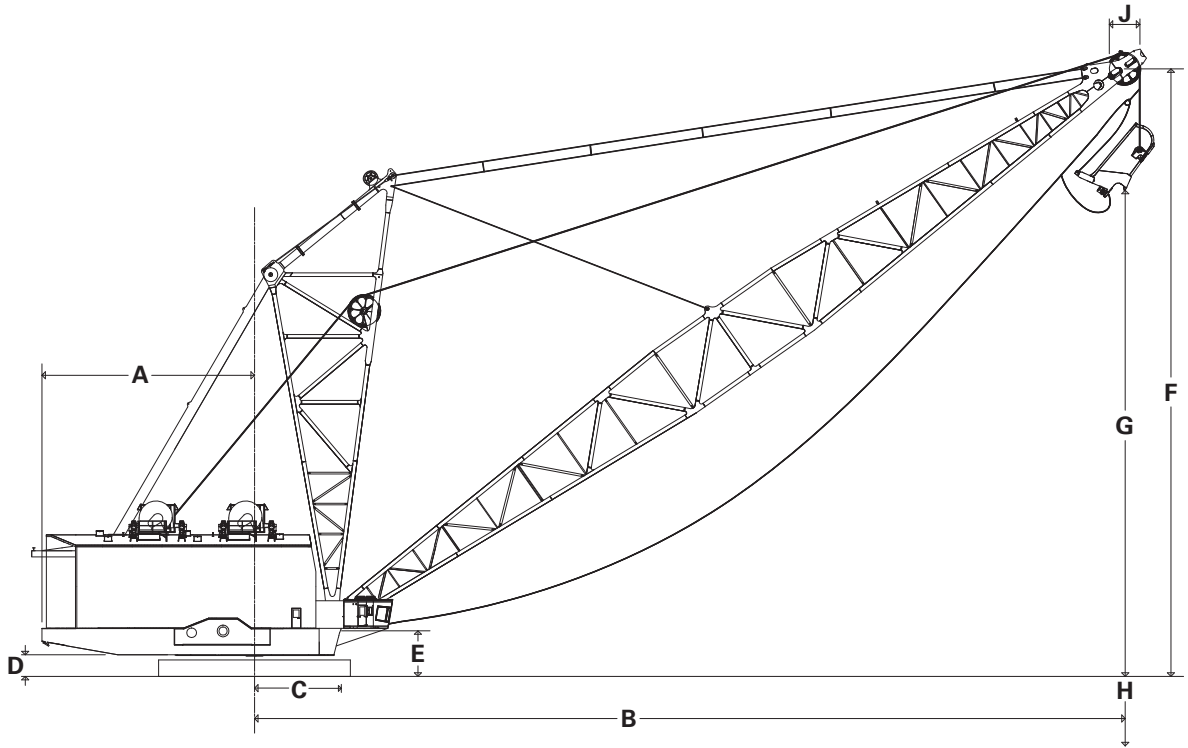

**MODEL**

**8200**

	100 m	328'0"	100 m	328'0"	100 m	328'0"
<b>Boom Length</b>						
<b>Boom Angle</b>	39°		35°		32°	
<b>Rated Suspension Load</b>	181 437 kg	400,000 lb	181 437 kg	400,000 lb	172 365 kg	380,000 lb
<b>Dimensions/Working Ranges</b>						
<b>A</b> Clearance Radius	21.6 m	71'0"	21.6 m	71'0"	21.6 m	71'0"
<b>B</b> Operating Radius	85.6 m	281.0'	90.1 m	295.5'	92.7 m	304.0'
<b>C</b> Boom Foot Radius	6.6 m	21'6"	6.6 m	21'6"	6.6 m	21'6"
<b>D</b> Clearance Height	2.2 m	7'3"	2.2 m	7'3"	2.2 m	7'3"
<b>E</b> Boom Foot Height	4.7 m	15'6"	4.7 m	15'6"	4.7 m	15'6"
<b>F</b> Boom Point Height	69.1 m	226.8'	62.6 m	205.4'	58.7 m	192.7'
<b>G</b> Dumping Height	48.2 m	158'0"	41.8 m	137'0"	38.1 m	125'0"
<b>H</b> Digging Depth	39.6 m	130'0"	46.3 m	152'0"	49.7 m	163'0"
<b>J</b> Point Sheave Pitch Diameter	304.8 cm	120"	304.8 cm	120"	304.8 cm	120"

MODEL	8750 – 22.9 m (75'0") Base			
Boom Length	109.7 m	360'0"	109.7 m	360'0"
Boom Angle	39°		35°	
Rated Suspension Load	294 840 kg	650,000 lb	294 840 kg	650,000 lb
Weights*				
Net Weight, Domestic (approximate with bucket)	5 502 075 kg	12,130,000 lb		*
Working Weight (approximate with bucket)	5 955 668 kg	13,130,000 lb		*
Ballast Weight (approximate)	453 592 kg	1,000,000 lb		*
Drag Rope				
Drum Diameter	317.5 cm	125"	317.5 cm	125"
Number		2		2
Rope Diameter	11.8 cm	4.63"	11.8 cm	4.63"
Hoist Rope				
Drum Diameter	317.5 cm	125"	317.5 cm	125"
Number		2		2
Rope Diameter	11.8 cm	4.63"	11.8 cm	4.63"
Electrical				
IGBT-AFE Inverter Cabinets	(4) or (5) water cooled		(4) or (5) water cooled	
Hoist Motors	(6) to (8) x 1230 kW	(6) to (8) x 1650 applied hp	(6) to (8) x 1230 kW	(6) to (8) x 1650 applied hp
Drag Motors	(6) to (8) x 1230 kW	(6) to (8) x 1650 applied hp	(6) to (8) x 1230 kW	(6) to (8) x 1650 applied hp
Swing Motors	(7) to (8) x 932 kW	(7) to (8) x 1250 applied hp	(7) to (8) x 932 kW	(7) to (8) x 1250 applied hp
Walking Motors	(4) x 932 kW	(4) x 1250 applied hp	(4) x 932 kW	(4) x 1250 applied hp
Base				
Outside Diameter	22.9 m	75'0"	22.9 m	75'0"
Bearing Area	410.5 m <sup>2</sup>	4418 ft <sup>2</sup>	410.5 m <sup>2</sup>	4418 ft <sup>2</sup>
Bearing Pressure*	137.9-147.5 kPa	20.00-21.40 psi	137.9-147.5 kPa	20.00-21.40 psi
Circle Rail Diameter	16.8 m	55'0"	16.8 m	55'0"
Rollers (average diameter)	35.6 cm	14"	35.6 cm	14"
Swing Gear (pitch diameter)	13.87 m	45'6"	13.87 m	45'6"
Walking Mounting				
Shoe Width and Length	4.3 m x 21.3 m	14'0" x 70'0"	2.7 m x 14.6 m	14'0" x 70'0"
Combined Bearing Area	182.1 m <sup>2</sup>	1960 ft <sup>2</sup>	80.3 m <sup>2</sup>	1960 ft <sup>2</sup>
Bearing Pressure (@ 80% of working weight)	256.5-268.9 kPa	37.2-39.0 psi	21.6 m	37.2-39.0 psi
Overall Width over Shoes	32.3 m	106'0"	2.1 m	106'0"
Length of Step (approximate)	2.13 m	7'0"	0.24 km/h	7'0"
Bucket Capacity	76-116 m <sup>3</sup>	100-152 yd <sup>3</sup>	76-116 m <sup>3</sup>	100-152 yd <sup>3</sup>

\*Net weight, ballast weight, working weight, bearing pressure (kPa/psi) will vary with boom length, angle, and rated suspended load.

**NOTE:** Motor combinations and IGBT-AFE Inverter Cabinets vary with boom length, angle, and rated suspension load.

MODEL	8750 – 22.9 m (75'0") Base					
Boom Length	117.3 m	385'0"	117.3 m	385'0"	117.3 m	385'0"
Boom Angle	39°		35°		32°	
Rated Suspension Load	278 964 kg	615,000 lb	278 964 kg	615,000 lb	263 088 kg	580,000 lb
Weights*						
Net Weight, Domestic (approximate with bucket)	5 497 540 kg	12,120,000 lb	*	*	*	*
Working Weight (approximate with bucket)	6 078 138 kg	13,400,000 lb	*	*	*	*
Ballast Weight (approximate)	580 598 kg	1,280,000 lb	*	*	*	*
Drag Rope						
Drum Diameter	317.5 cm	125"	317.5 cm	125"	317.5 cm	125"
Number	2		2		2	
Rope Diameter	11.8 cm	4.63"	11.8 cm	4.63"	11.4 cm	4.5"
Hoist Rope						
Drum Diameter	317.5 cm	125"	317.5 cm	125"	317.5 cm	125"
Number	2		2		2	
Rope Diameter	11.8 cm	4.63"	11.8 cm	4.63"	11.4 cm	4.5"
Electrical						
IGBT-AFE Inverter Cabinets	(4) or (5) water cooled		(4) or (5) water cooled		(4) or (5) water cooled	
Hoist Motors	(6) to (8) x 1230 kW	(6) to (8) x 1650 applied hp	(6) to (8) x 1230 kW	(6) to (8) x 1650 applied hp	(6) to (8) x 1230 kW	(6) to (8) x 1650 applied hp
Drag Motors	(6) to (8) x 1230 kW	(6) to (8) x 1650 applied hp	(6) to (8) x 1230 kW	(6) to (8) x 1650 applied hp	(6) to (8) x 1230 kW	(6) to (8) x 1650 applied hp
Swing Motors	(7) to (8) x 932 kW	(7) to (8) x 1250 applied hp	(7) to (8) x 932 kW	(7) to (8) x 1250 applied hp	(7) to (8) x 932 kW	(7) to (8) x 1250 applied hp
Walking Motors	(4) x 932 kW	(4) x 1250 applied hp	(4) x 932 kW	(4) x 1250 applied hp	(4) x 932 kW	(4) x 1250 applied hp
Base						
Outside Diameter	22.9 m	75'0"	22.9 m	75'0"	22.9 m	75'0"
Bearing Area	410.5 m <sup>2</sup>	4418 ft <sup>2</sup>	410.5 m <sup>2</sup>	4418 ft <sup>2</sup>	410.5 m <sup>2</sup>	4418 ft <sup>2</sup>
Bearing Pressure*	137.9-147.5 kPa	20.00-21.40 psi	137.9-147.5 kPa	20.00-21.40 psi	137.9-147.5 kPa	20.00-21.40 psi
Circle Rail Diameter	16.8 m	55'0"	16.8 m	55'0"	16.8 m	55'0"
Rollers (average diameter)	35.6 cm	14"	35.6 cm	14"	35.6 cm	14"
Swing Gear (pitch diameter)	13.87 m	45'6"	13.87 m	45'6"	13.87 m	45'6"
Walking Mounting						
Shoe Width and Length	4.3 m x 21.3 m	14'0" x 70'0"	4.3 m x 21.3 m	14'0" x 70'0"	4.3 m x 21.3 m	14'0" x 70'0"
Combined Bearing Area	182.1 m <sup>2</sup>	1960 ft <sup>2</sup>	182.1 m <sup>2</sup>	1960 ft <sup>2</sup>	182.1 m <sup>2</sup>	1960 ft <sup>2</sup>
Bearing Pressure (@ 80% of working weight)	256.5-268.9 kPa	37.2-39.0 psi	256.5-268.9 kPa	37.2-39.0 psi	256.5-268.9 kPa	37.2-39.0 psi
Overall Width over Shoes	32.3 m	106'0"	32.3 m	106'0"	32.3 m	106'0"
Length of Step (approximate)	2.13 m	7'0"	2.13 m	7'0"	2.13 m	7'0"
Bucket Capacity	76-116 m <sup>3</sup>	100-152 yd <sup>3</sup>	76-116 m <sup>3</sup>	100-152 yd <sup>3</sup>	76-116 m <sup>3</sup>	100-152 yd <sup>3</sup>

\*Net weight, ballast weight, working weight, bearing pressure (kPa/psi) will vary with boom length, angle, and rated suspended load.  
 NOTE: Motor combinations and IGBT-AFE Inverter Cabinets vary with boom length, angle, and rated suspension load.

MODEL	8750 – 22.9 m (75'0") Base					
Boom Length	124.9 m	410'0"	124.9 m	410'0"	124.9 m	410'0"
Boom Angle	39°		35°		32°	
Rated Suspension Load	249 480 kg	550,000 lb	242 676 kg	535,000 lb	226 800 kg	500,000 lb
Weights*						
Net Weight, Domestic (approximate with bucket)	5 535 188 kg	12,203,000 lb	*	*	*	*
Working Weight (approximate with bucket)	6 182 464 kg	13,630,000 lb	*	*	*	*
Ballast Weight (approximate)	647 276 kg	1,427,000 lb	*	*	*	*
Drag Rope						
Drum Diameter	317.5 cm	125"	317.5 cm	125"	317.5 cm	125"
Number	2	2	2	2	2	2
Rope Diameter	11.4 cm	4.5"	10.8 cm	4.25"	10.8 cm	4.25"
Hoist Rope						
Drum Diameter	317.5 cm	125"	317.5 cm	125"	317.5 cm	125"
Number	2	2	2	2	2	2
Rope Diameter	11.4 cm	4.5"	10.8 cm	4.25"	10.8 cm	4.25"
Electrical						
IGBT-AFE Inverter Cabinets	(4) or (5) water cooled		(4) or (5) water cooled		(4) or (5) water cooled	
Hoist Motors	(6) to (8) x 1230 kW	(6) to (8) x 1650 applied hp	(6) to (8) x 1230 kW	(6) to (8) x 1650 applied hp	(6) to (8) x 1230 kW	(6) to (8) x 1650 applied hp
Drag Motors	(6) to (8) x 1230 kW	(6) to (8) x 1650 applied hp	(6) to (8) x 1230 kW	(6) to (8) x 1650 applied hp	(6) to (8) x 1230 kW	(6) to (8) x 1650 applied hp
Swing Motors	(7) to (8) x 932 kW	(7) to (8) x 1250 applied hp	(7) to (8) x 932 kW	(7) to (8) x 1250 applied hp	(7) to (8) x 932 kW	(7) to (8) x 1250 applied hp
Walking Motors	(4) x 932 kW	(4) x 1250 applied hp	(4) x 932 kW	(4) x 1250 applied hp	(4) x 932 kW	(4) x 1250 applied hp
Base						
Outside Diameter	22.9 m	75'0"	22.9 m	75'0"	22.9 m	75'0"
Bearing Area	410.5 m <sup>2</sup>	4418 ft <sup>2</sup>	410.5 m <sup>2</sup>	4418 ft <sup>2</sup>	410.5 m <sup>2</sup>	4418 ft <sup>2</sup>
Bearing Pressure*	137.9-147.5 kPa	20.00-21.40 psi	137.9-147.5 kPa	20.00-21.40 psi	137.9-147.5 kPa	20.00-21.40 psi
Circle Rail Diameter	16.8 m	55'0"	16.8 m	55'0"	16.8 m	55'0"
Rollers (average diameter)	35.6 cm	14"	35.6 cm	14"	35.6 cm	14"
Swing Gear (pitch diameter)	13.87 m	45'6"	13.87 m	45'6"	13.87 m	45'6"
Walking Mounting						
Shoe Width and Length	4.3 m x 21.3 m	14'0" x 70'0"	4.3 m x 21.3 m	14'0" x 70'0"	4.3 m x 21.3 m	14'0" x 70'0"
Combined Bearing Area	182.1 m <sup>2</sup>	1960 ft <sup>2</sup>	182.1 m <sup>2</sup>	1960 ft <sup>2</sup>	182.1 m <sup>2</sup>	1960 ft <sup>2</sup>
Bearing Pressure (@ 80% of working weight)	256.5-268.9 kPa	37.2-39.0 psi	256.5-268.9 kPa	37.2-39.0 psi	256.5-268.9 kPa	37.2-39.0 psi
Overall Width over Shoes	32.3 m	106'0"	32.3 m	106'0"	32.3 m	106'0"
Length of Step (approximate)	2.13 m	7'0"	2.13 m	7'0"	2.13 m	7'0"
Bucket Capacity	76-116 m <sup>3</sup>	100-152 yd <sup>3</sup>	76-116 m <sup>3</sup>	100-152 yd <sup>3</sup>	76-116 m <sup>3</sup>	100-152 yd <sup>3</sup>

\*Net weight, ballast weight, working weight, bearing pressure (kPa/psi) will vary with boom length, angle, and rated suspended load.  
NOTE: Motor combinations and IGBT-AFE Inverter Cabinets vary with boom length, angle, and rated suspension load.

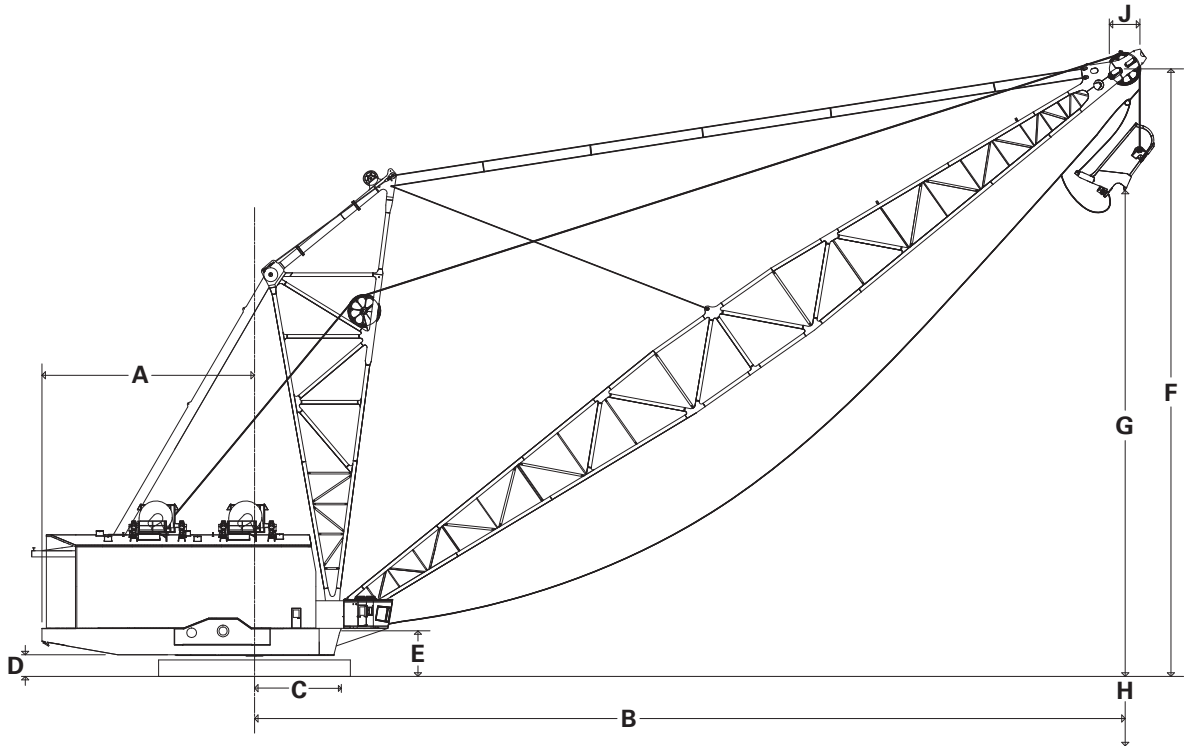

**MODEL**

**8750 – 22.9 m (75'0") Base**

	109.7 m	360'0"	109.7 m	360'0"
<b>Boom Length</b>	109.7 m	360'0"	109.7 m	360'0"
<b>Boom Angle</b>	39°		35°	
<b>Rated Suspension Load</b>	294 835 kg	650,000 lb	294 835 kg	650,000 lb
<b>Dimensions/Working Ranges</b>				
<b>A</b> Clearance Radius	27.9 m	91'8"	27.9 m	91'8"
<b>B</b> Operating Radius	94.5 m	310'0"	99.1 m	325'0"
<b>C</b> Boom Foot Radius	7.3 m	24'0"	7.3 m	24'0"
<b>D</b> Clearance Height	4.1 m	13'4"	4.1 m	13'4"
<b>E</b> Boom Foot Height	5.1 m	16'10"	5.1 m	16'10"
<b>F</b> Boom Point Height	74.2 m	243.5'	68.07 m	223.3'
<b>G</b> Dumping Height	52.1 m	171'0"	46.3 m	152'0"
<b>H</b> Digging Depth	60.7 m	199'0"	66.4 m	218'0"
<b>J</b> Point Sheave Pitch Diameter	353.1 cm	139"	353.1 cm	139"

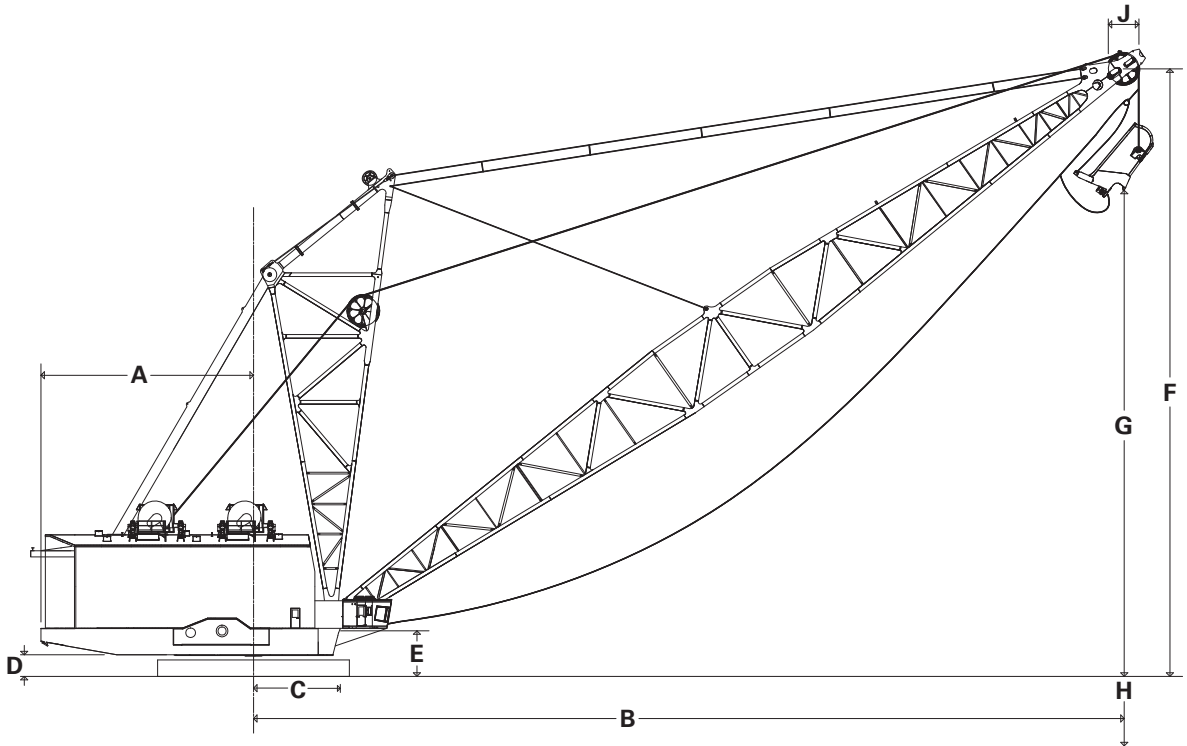

**MODEL**

**8750 – 22.9 m (75'0") Base**

	117.3 m	385'0"	117.3 m	385'0"	117.3 m	385'0"
<b>Boom Length</b>	117.3 m	385'0"	117.3 m	385'0"	117.3 m	385'0"
<b>Boom Angle</b>	39°		35°		32°	
<b>Rated Suspension Load</b>	278 964 kg	615,000 lb	278 964 kg	615,000 lb	263 088 kg	580,000 lb
<b>Dimensions/Working Ranges</b>						
<b>A</b> Clearance Radius	27.9 m	91'8"	27.9 m	91'8"	27.9 m	91'8"
<b>B</b> Operating Radius	100.2 m	329'0"	105.1 m	345'0"	108.5 m	356'0"
<b>C</b> Boom Foot Radius	7.3 m	24'0"	7.3 m	24'0"	7.3 m	24'0"
<b>D</b> Clearance Height	4.1 m	13'4"	4.1 m	13'4"	4.1 m	13'4"
<b>E</b> Boom Foot Height	5.1 m	16'10"	5.1 m	16'10"	5.1 m	16'10"
<b>F</b> Boom Point Height	78.9 m	259.1'	72.4 m	237.6'	67.4 m	130.8'
<b>G</b> Dumping Height	57.3 m	188'0"	50.5 m	166'0"	46.3 m	152'0"
<b>H</b> Digging Depth	55.5 m	182'0"	62.2 m	204'0"	66.1 m	217'0"
<b>J</b> Point Sheave Pitch Diameter	353.1 cm	139"	353.1 cm	139"	353.1 cm	139"

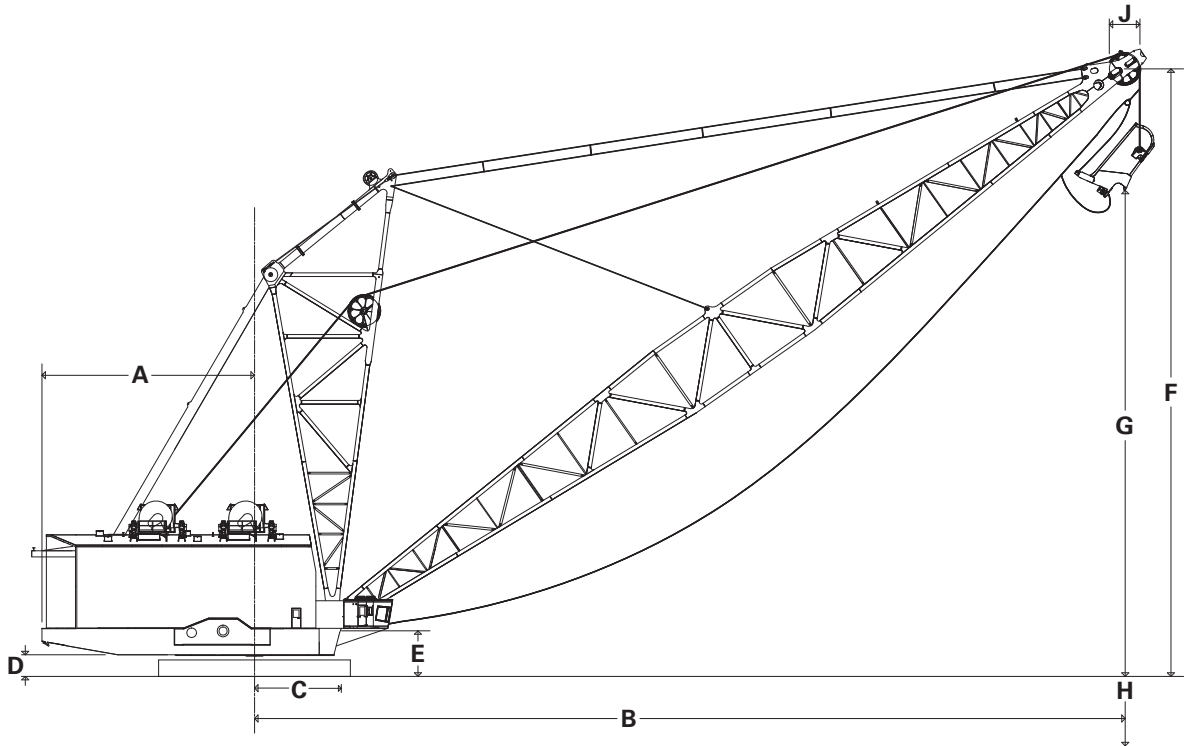

**MODEL**

**8750 – 22.9 m (75'0") Base**

	124.9 m	410'0"	124.9 m	410'0"	124.9 m	410'0"
<b>Boom Length</b>	124.9 m	410'0"	124.9 m	410'0"	124.9 m	410'0"
<b>Boom Angle</b>	39°		35°		32°	
<b>Rated Suspension Load</b>	249 480 kg	550,000 lb	242 676 kg	535,000 lb	226 800 kg	500,000 lb
<b>Dimensions/Working Ranges</b>						
<b>A</b> Clearance Radius	27.9 m	91'8"	27.9 m	91'8"	27.9 m	91'8"
<b>B</b> Operating Radius	106.1 m	348'0"	111.5 m	366'0"	114.9 m	377'0"
<b>C</b> Boom Foot Radius	7.3 m	24'0"	7.3 m	24'0"	7.3 m	24'0"
<b>D</b> Clearance Height	4.1 m	13'4"	4.1 m	13'4"	4.1 m	13'4"
<b>E</b> Boom Foot Height	5.1 m	16'10"	5.1 m	16'10"	5.1 m	16'10"
<b>F</b> Boom Point Height	83.7 m	274.8'	76.8 m	252.0'	71.3 m	234.1'
<b>G</b> Dumping Height	62.7 m	206'0"	56.7 m	186'0"	51.2 m	168'0"
<b>H</b> Digging Depth	49.7 m	163'0"	55.8 m	183'0"	61.3 m	201'0"
<b>J</b> Point Sheave Pitch Diameter	353.1 cm	139"	353.1 cm	139"	353.1 cm	139"

MODEL	8750 – 25.6 m (84'0") Base					
Boom Length	109.7 m	360'0"	109.7 m	360'0"	109.7 m	360'0"
Boom Angle	39°		35°		32°	
Rated Suspension Load	344 736 kg	760,000 lb	344 736 kg	760,000 lb	322 056 kg	710,000 lb
Weights*						
Net Weight, Domestic (approximate with bucket)	6 597 500 kg	14,545,000 lb	*	*	*	*
Working Weight (approximate with bucket)	6 876 006 kg	15,159,000 lb	*	*	*	*
Ballast Weight (approximate)	278 505 kg	614,000 lb	*	*	*	*
Drag Rope						
Drum Diameter	330.2 cm	130"	330.2 cm	130"	330.2 cm	130"
Number	2		2		2	
Rope Diameter	13.03 cm	5.13"	13.03 cm	5.13"	12.70 cm	5.00"
Hoist Rope						
Drum Diameter	330.2 cm	130"	330.2 cm	130"	330.2 cm	130"
Number	2		2		2	
Rope Diameter	13.03 cm	5.13"	13.03 cm	5.13"	12.70 cm	5.00"
Electrical						
IGBT-AFE Inverter Cabinets	(4) or (5) water cooled		(4) or (5) water cooled		(4) or (5) water cooled	
Hoist Motors	(6) to (8) × 1230 kW	(6) to (8) × 1650 applied hp	(6) to (8) × 1230 kW	(6) to (8) × 1650 applied hp	(6) to (8) × 1230 kW	(6) to (8) × 1650 applied hp
Drag Motors	(6) to (8) × 1230 kW	(6) to (8) × 1650 applied hp	(6) to (8) × 1230 kW	(6) to (8) × 1650 applied hp	(6) to (8) × 1230 kW	(6) to (8) × 1650 applied hp
Swing Motors	(8) to (10) × 932 kW	(8) to (10) × 1250 applied hp	(8) to (10) × 932 kW	(8) to (10) × 1250 applied hp	(8) to (10) × 932 kW	(8) to (10) × 1250 applied hp
Walking Motors	(4) × 932 kW	(4) × 1250 applied hp	(4) × 932 kW	(4) × 1250 applied hp	(4) × 932 kW	(4) × 1250 applied hp
Base						
Outside Diameter	25.6 m	84'0"	25.6 m	84'0"	25.6 m	84'0"
Bearing Area	514.85 m <sup>2</sup>	5542 ft <sup>2</sup>	514.85 m <sup>2</sup>	5542 ft <sup>2</sup>	514.85 m <sup>2</sup>	5542 ft <sup>2</sup>
Bearing Pressure*	131.0-140.6 kPa	19.00-20.39 psi	131.0-140.6 kPa	19.00-20.39 psi	131.0-140.6 kPa	19.00-20.39 psi
Circle Rail Diameter	16.8 m	55'0"	16.8 m	55'0"	16.8 m	55'0"
Rollers (average diameter)	40.6 cm	16"	40.6 cm	16"	40.6 cm	16"
Swing Gear (pitch diameter)	13.87 m	45'6"	13.87 m	45'6"	13.87 m	45'6"
Walking Mounting						
Shoe Width and Length	4.9 m × 24.4 m	16'0" × 80'0"	4.9 m × 24.4 m	16'0" × 80'0"	4.9 m × 24.4 m	16'0" × 80'0"
Combined Bearing Area	237.8 m <sup>2</sup>	2560 ft <sup>2</sup>	237.8 m <sup>2</sup>	2560 ft <sup>2</sup>	237.8 m <sup>2</sup>	2560 ft <sup>2</sup>
Bearing Pressure (@ 80% of working weight)	226.8-243.5 kPa	32.90-35.32 psi	226.8-243.5 kPa	32.90-35.32 psi	226.8-243.5 kPa	32.90-35.32 psi
Overall Width over Shoes	37.08 m	121'8"	37.08 m	121'8"	37.08 m	121'8"
Length of Step (approximate)	2.28 m	7'6"	2.28 m	7'6"	2.28 m	7'6"
Bucket Capacity	76-116 m <sup>3</sup>	100-152 yd <sup>3</sup>	76-116 m <sup>3</sup>	100-152 yd <sup>3</sup>	76-116 m <sup>3</sup>	100-152 yd <sup>3</sup>

\*Net weight, ballast weight, working weight, bearing pressure (kPa/psi) will vary with boom length, angle, and rated suspended load.  
NOTE: Motor combinations and IGBT-AFE Inverter Cabinets vary with boom length, angle, and rated suspension load.



MODEL	8750 – 25.6 m (84'0") Base					
Boom Length	117.3 m	385'0"	117.3 m	385'0"	117.3 m	385'0"
Boom Angle	39°		35°		32°	
Rated Suspension Load	344 736 kg	760,000 lb	344 736 kg	760,000 lb	283 500 kg	625,000 lb
Weights*						
Net Weight, Domestic (approximate with bucket)	6 705 000 kg	14,782,000 lb	*	*	*	*
Working Weight (approximate with bucket)	7 125 480 kg	15,709,000 lb	*	*	*	*
Ballast Weight (approximate)	420 480 kg	927,000 lb	*	*	*	*
Drag Rope						
Drum Diameter	330.2 cm	130"	330.2 cm	130"	330.2 cm	130"
Number	2		2		2	
Rope Diameter	13.03 cm	5.13"	13.03 cm	5.13"	11.76 cm	4.63"
Hoist Rope						
Drum Diameter	330.2 cm	130"	330.2 cm	130"	330.2 cm	130"
Number	2		2		2	
Rope Diameter	13.03 cm	5.13"	13.03 cm	5.13"	11.76 cm	4.63"
Electrical						
IGBT-AFE Inverter Cabinets	(4) or (5) water cooled		(4) or (5) water cooled		(4) or (5) water cooled	
Hoist Motors	(6) to (8) x 1230 kW	(6) to (8) x 1650 applied hp	(6) to (8) x 1230 kW	(6) to (8) x 1650 applied hp	(6) to (8) x 1230 kW	(6) to (8) x 1650 applied hp
Drag Motors	(6) to (8) x 1230 kW	(6) to (8) x 1650 applied hp	(6) to (8) x 1230 kW	(6) to (8) x 1650 applied hp	(6) to (8) x 1230 kW	(6) to (8) x 1650 applied hp
Swing Motors	(8) to (10) x 932 kW	(8) to (10) x 1250 applied hp	(8) to (10) x 932 kW	(8) to (10) x 1250 applied hp	(8) to (10) x 932 kW	(8) to (10) x 1250 applied hp
Walking Motors	(4) x 932 kW	(4) x 1250 applied hp	(4) x 932 kW	(4) x 1250 applied hp	(4) x 932 kW	(4) x 1250 applied hp
Base						
Outside Diameter	25.6 m	84'0"	25.6 m	84'0"	25.6 m	84'0"
Bearing Area	514.85 m <sup>2</sup>	5542 ft <sup>2</sup>	514.85 m <sup>2</sup>	5542 ft <sup>2</sup>	514.85 m <sup>2</sup>	5542 ft <sup>2</sup>
Bearing Pressure*	131.0-140.6 kPa	19.00-20.39 psi	131.0-140.6 kPa	19.00-20.39 psi	131.0-140.6 kPa	19.00-20.39 psi
Circle Rail Diameter	16.8 m	55'0"	16.8 m	55'0"	16.8 m	55'0"
Rollers (average diameter)	40.6 cm	16"	40.6 cm	16"	40.6 cm	16"
Swing Gear (pitch diameter)	13.87 m	45'6"	13.87 m	45'6"	13.87 m	45'6"
Walking Mounting						
Shoe Width and Length	4.9 m x 24.4 m	16'0" x 80'0"	4.9 m x 24.4 m	16'0" x 80'0"	4.9 m x 24.4 m	16'0" x 80'0"
Combined Bearing Area	237.8 m <sup>2</sup>	2560 ft <sup>2</sup>	237.8 m <sup>2</sup>	2560 ft <sup>2</sup>	237.8 m <sup>2</sup>	2560 ft <sup>2</sup>
Bearing Pressure (@ 80% of working weight)	226.8-243.5 kPa	32.90-35.32 psi	226.8-243.5 kPa	32.90-35.32 psi	226.8-243.5 kPa	32.90-35.32 psi
Overall Width over Shoes	37.08 m	121'8"	37.08 m	121'8"	37.08 m	121'8"
Length of Step (approximate)	2.28 m	7'6"	2.28 m	7'6"	2.28 m	7'6"
Bucket Capacity	76-116 m <sup>3</sup>	100-152 yd <sup>3</sup>	76-116 m <sup>3</sup>	100-152 yd <sup>3</sup>	76-116 m <sup>3</sup>	100-152 yd <sup>3</sup>

\*Net weight, ballast weight, working weight, bearing pressure (kPa/psi) will vary with boom length, angle, and rated suspended load.

NOTE: Motor combinations and IGBT-AFE Inverter Cabinets vary with boom length, angle, and rated suspension load.

**MODEL**

**8750 – 25.6 m (84'0") Base**

Boom Length	124.9 m 410'0"	124.9 m 410'0"	124.9 m 410'0"	124.9 m 410'0"	124.9 m 410'0"	
Boom Angle	39°		35°		32°	
Rated Suspension Load	306 180 kg 675,000 lb	317 520 kg 700,000 lb	272 160 kg 600,000 lb	306 180 kg 675,000 lb	317 520 kg 700,000 lb	272 160 kg 600,000 lb
Weights*						
Net Weight, Domestic (approximate with bucket)	6 709 992 kg 14,793,000 lb	*	*	*	*	*
Working Weight (approximate with bucket)	7 223 005 kg 15,924,000 lb	*	*	*	*	*
Ballast Weight (approximate)	513 013 kg 1,131,000 lb	*	*	*	*	*
Drag Rope						
Drum Diameter	330.2 cm 130"	330.2 cm 130"	330.2 cm 130"	330.2 cm 130"	330.2 cm 130"	330.2 cm 130"
Number	2	2	2	2	2	2
Rope Diameter	12.06 cm 4.75"	12.70 cm 5.00"	12.70 cm 5.00"	11.76 cm 4.63"	11.76 cm 4.63"	11.76 cm 4.63"
Hoist Rope						
Drum Diameter	330.2 cm 130"	330.2 cm 130"	330.2 cm 130"	330.2 cm 130"	330.2 cm 130"	330.2 cm 130"
Number	2	2	2	2	2	2
Rope Diameter	12.06 cm 4.75"	12.70 cm 5.00"	12.70 cm 5.00"	11.76 cm 4.63"	11.76 cm 4.63"	11.76 cm 4.63"
Electrical						
IGBT-AFE Inverter Cabinets	(4) or (5) water cooled		(4) or (5) water cooled		(4) or (5) water cooled	
Hoist Motors	(6) to (8) x 1230 kW x 1650 applied hp	(6) to (8) x 1650 applied hp	(6) to (8) x 1230 kW x 1650 applied hp	(6) to (8) x 1650 applied hp	(6) to (8) x 1230 kW x 1650 applied hp	(6) to (8) x 1650 applied hp
Drag Motors	(6) to (8) x 1230 kW x 1650 applied hp	(6) to (8) x 1650 applied hp	(6) to (8) x 1230 kW x 1650 applied hp	(6) to (8) x 1650 applied hp	(6) to (8) x 1230 kW x 1650 applied hp	(6) to (8) x 1650 applied hp
Swing Motors	(8) to (10) x 932 kW x 1250 applied hp	(8) to (10) x 1250 applied hp	(8) to (10) x 932 kW x 1250 applied hp	(8) to (10) x 1250 applied hp	(8) to (10) x 932 kW x 1250 applied hp	(8) to (10) x 1250 applied hp
Walking Motors	(4) x 932 kW applied hp	(4) x 1250 applied hp	(4) x 932 kW applied hp	(4) x 1250 applied hp	(4) x 932 kW applied hp	(4) x 1250 applied hp
Base						
Outside Diameter	25.6 m 84'0"	25.6 m 84'0"	25.6 m 84'0"	25.6 m 84'0"	25.6 m 84'0"	25.6 m 84'0"
Bearing Area	514.85 m <sup>2</sup> 5542 ft <sup>2</sup>	514.85 m <sup>2</sup> 5542 ft <sup>2</sup>	514.85 m <sup>2</sup> 5542 ft <sup>2</sup>	514.85 m <sup>2</sup> 5542 ft <sup>2</sup>	514.85 m <sup>2</sup> 5542 ft <sup>2</sup>	514.85 m <sup>2</sup> 5542 ft <sup>2</sup>
Bearing Pressure*	131.0-140.6 kPa 19.00-20.39 psi	131.0-140.6 kPa 19.00-20.39 psi	131.0-140.6 kPa 19.00-20.39 psi	131.0-140.6 kPa 19.00-20.39 psi	131.0-140.6 kPa 19.00-20.39 psi	131.0-140.6 kPa 19.00-20.39 psi
Circle Rail Diameter	16.8 m 55'0"	16.8 m 55'0"	16.8 m 55'0"	16.8 m 55'0"	16.8 m 55'0"	16.8 m 55'0"
Rollers (average diameter)	40.6 cm 16"	40.6 cm 16"	40.6 cm 16"	40.6 cm 16"	40.6 cm 16"	40.6 cm 16"
Swing Gear (pitch diameter)	13.87 m 45'6"	13.87 m 45'6"	13.87 m 45'6"	13.87 m 45'6"	13.87 m 45'6"	13.87 m 45'6"
Walking Mounting						
Shoe Width and Length	4.9 m x 24.4 m 16'0" x 80'0"	4.9 m x 24.4 m 16'0" x 80'0"	4.9 m x 24.4 m 16'0" x 80'0"	4.9 m x 24.4 m 16'0" x 80'0"	4.9 m x 24.4 m 16'0" x 80'0"	4.9 m x 24.4 m 16'0" x 80'0"
Combined Bearing Area	237.8 m <sup>2</sup> 2560 ft <sup>2</sup>	237.8 m <sup>2</sup> 2560 ft <sup>2</sup>	237.8 m <sup>2</sup> 2560 ft <sup>2</sup>	237.8 m <sup>2</sup> 2560 ft <sup>2</sup>	237.8 m <sup>2</sup> 2560 ft <sup>2</sup>	237.8 m <sup>2</sup> 2560 ft <sup>2</sup>
Bearing Pressure (@ 80% of working weight)	226.8-243.5 kPa 32.90-35.32 psi	226.8-243.5 kPa 32.90-35.32 psi	226.8-243.5 kPa 32.90-35.32 psi	226.8-243.5 kPa 32.90-35.32 psi	226.8-243.5 kPa 32.90-35.32 psi	226.8-243.5 kPa 32.90-35.32 psi
Overall Width over Shoes	37.08 m 121'8"	37.08 m 121'8"	37.08 m 121'8"	37.08 m 121'8"	37.08 m 121'8"	37.08 m 121'8"
Length of Step (approximate)	2.28 m 7'6"	2.28 m 7'6"	2.28 m 7'6"	2.28 m 7'6"	2.28 m 7'6"	2.28 m 7'6"
Bucket Capacity	76-116 m <sup>3</sup> 100-152 yd <sup>3</sup>	76-116 m <sup>3</sup> 100-152 yd <sup>3</sup>	76-116 m <sup>3</sup> 100-152 yd <sup>3</sup>	76-116 m <sup>3</sup> 100-152 yd <sup>3</sup>	76-116 m <sup>3</sup> 100-152 yd <sup>3</sup>	76-116 m <sup>3</sup> 100-152 yd <sup>3</sup>

\*Net weight, ballast weight, working weight, bearing pressure (kPa/psi) will vary with boom length, angle, and rated suspended load.  
NOTE: Motor combinations and IGBT-AFE Inverter Cabinets vary with boom length, angle, and rated suspension load.

MODEL	8750 – 25.6 m (84'0") Base					
Boom Length	132.5 m	435'0"	132.5 m	435'0"	132.5 m	435'0"
Boom Angle	39°		35°		32°	
Rated Suspension Load	263 088 kg	580,000 lb	254 016 kg	560,000 lb	240 404 kg	530,000 lb
Weights*						
Net Weight, Domestic (approximate with bucket)	6 672 341 kg	14,710,000 lb	*	*	*	*
Working Weight (approximate with bucket)	7 202 140 kg	15,878,000 lb	*	*	*	*
Ballast Weight (approximate)	529 796 kg	1,168,000 lb	*	*	*	*
Drag Rope						
Drum Diameter	330.2 cm	130"	330.2 cm	130"	330.2 cm	130"
Number	2		2		2	
Rope Diameter	11.43 cm	4.50"	11.43 cm	4.50"	11.43 cm	4.50"
Hoist Rope						
Drum Diameter	330.2 cm	130"	330.2 cm	130"	330.2 cm	130"
Number	2		2		2	
Rope Diameter	11.43 cm	4.50"	11.43 cm	4.50"	11.43 cm	4.50"
Electrical						
IGBT-AFE Inverter Cabinets	(4) or (5) water cooled		(4) or (5) water cooled		(4) or (5) water cooled	
Hoist Motors	(6) to (8) x 1230 kW	(6) to (8) x 1650 applied hp	(6) to (8) x 1230 kW	(6) to (8) x 1650 applied hp	(6) to (8) x 1230 kW	(6) to (8) x 1650 applied hp
Drag Motors	(6) to (8) x 1230 kW	(6) to (8) x 1650 applied hp	(6) to (8) x 1230 kW	(6) to (8) x 1650 applied hp	(6) to (8) x 1230 kW	(6) to (8) x 1650 applied hp
Swing Motors	(8) to (10) x 932 kW	(8) to (10) x 1250 applied hp	(8) to (10) x 932 kW	(8) to (10) x 1250 applied hp	(8) to (10) x 932 kW	(8) to (10) x 1250 applied hp
Walking Motors	(4) x 932 kW	(4) x 1250 applied hp	(4) x 932 kW	(4) x 1250 applied hp	(4) x 932 kW	(4) x 1250 applied hp
Base						
Outside Diameter	25.6 m	84'0"	25.6 m	84'0"	25.6 m	84'0"
Bearing Area	514.85 m <sup>2</sup>	5542 ft <sup>2</sup>	514.85 m <sup>2</sup>	5542 ft <sup>2</sup>	514.85 m <sup>2</sup>	5542 ft <sup>2</sup>
Bearing Pressure*	131.0-140.6 kPa	19.00-20.39 psi	131.0-140.6 kPa	19.00-20.39 psi	131.0-140.6 kPa	19.00-20.39 psi
Circle Rail Diameter	16.8 m	55'0"	16.8 m	55'0"	16.8 m	55'0"
Rollers (average diameter)	40.6 cm	16"	40.6 cm	16"	40.6 cm	16"
Swing Gear (pitch diameter)	13.87 m	45'6"	13.87 m	45'6"	13.87 m	45'6"
Walking Mounting						
Shoe Width and Length	4.9 m x 24.4 m	16'0" x 80'0"	4.9 m x 24.4 m	16'0" x 80'0"	4.9 m x 24.4 m	16'0" x 80'0"
Combined Bearing Area	237.8 m <sup>2</sup>	2560 ft <sup>2</sup>	237.8 m <sup>2</sup>	2560 ft <sup>2</sup>	237.8 m <sup>2</sup>	2560 ft <sup>2</sup>
Bearing Pressure (@ 80% of working weight)	226.8-243.5 kPa	32.90-35.32 psi	226.8-243.5 kPa	32.90-35.32 psi	226.8-243.5 kPa	32.90-35.32 psi
Overall Width over Shoes	37.08 m	121'8"	37.08 m	121'8"	37.08 m	121'8"
Length of Step (approximate)	2.28 m	7'6"	2.28 m	7'6"	2.28 m	7'6"
Bucket Capacity	76-116 m <sup>3</sup>	100-152 yd <sup>3</sup>	76-116 m <sup>3</sup>	100-152 yd <sup>3</sup>	76-116 m <sup>3</sup>	100-152 yd <sup>3</sup>

\*Net weight, ballast weight, working weight, bearing pressure (kPa/psi) will vary with boom length, angle, and rated suspended load.  
 NOTE: Motor combinations and IGBT-AFE Inverter Cabinets vary with boom length, angle, and rated suspension load.

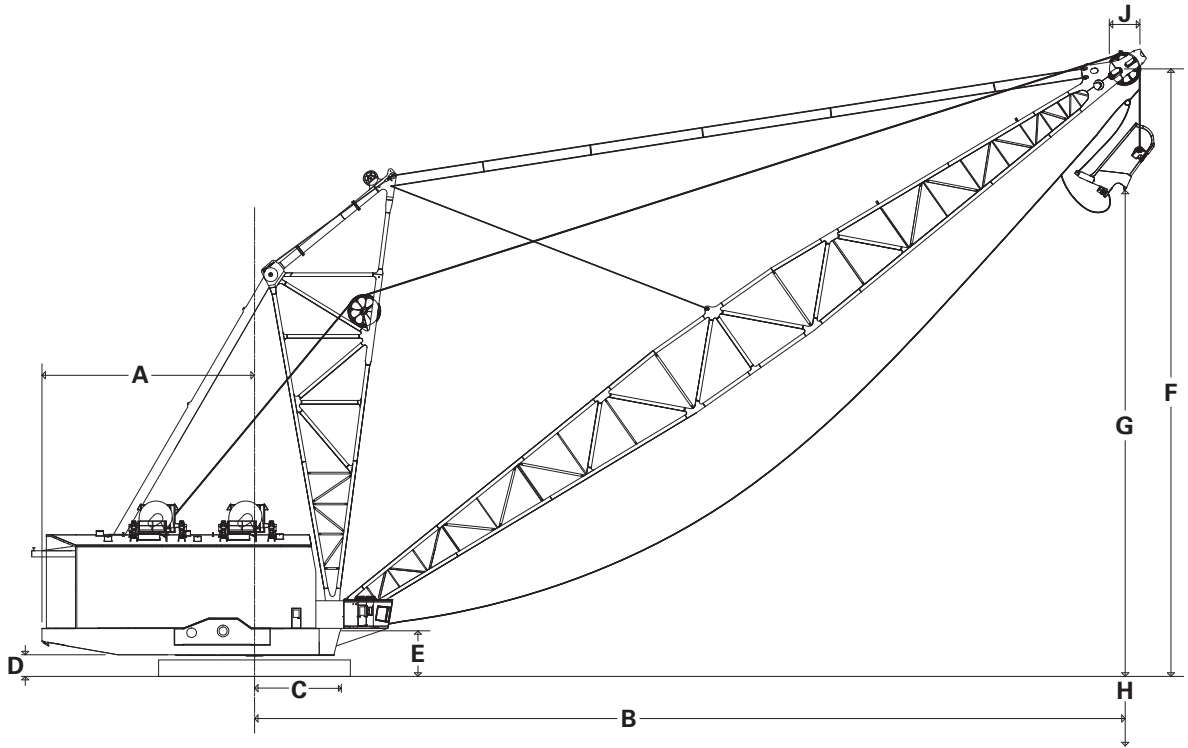

**MODEL**

**8750 – 25.6 m (84'0") Base**

	109.7 m	360'0"	109.7 m	360'0"	109.7 m	360'0"
<b>Boom Length</b>	109.7 m	360'0"	109.7 m	360'0"	109.7 m	360'0"
<b>Boom Angle</b>	39°		35°		32°	
<b>Rated Suspension Load</b>	344 730 kg	760,000 lb	344 730 kg	760,000 lb	322 051 kg	710,000 lb
<b>Dimensions/Working Ranges</b>						
<b>A</b> Clearance Radius	29.26 m	96'0"	29.26 m	96'0"	29.26 m	96'0"
<b>B</b> Operating Radius	94.5 m	310.0'	99.1 m	325.1'	102.2 m	335.5'
<b>C</b> Boom Foot Radius	7.3 m	24'0"	7.3 m	24'0"	7.3 m	24'0"
<b>D</b> Clearance Height	4.69 m	15'5"	4.69 m	15'5"	4.69 m	15'5"
<b>E</b> Boom Foot Height	6.5 m	21'6"	6.5 m	21'6"	6.5 m	21'6"
<b>F</b> Boom Point Height	75.6 m	248.0'	69.5 m	228.0'	64.7 m	212.3'
<b>G</b> Dumping Height	51.8 m	170'0"	45.7 m	150'0"	42.4 m	139'0"
<b>H</b> Digging Depth	64.3 m	211'0"	70.4 m	231'0"	73.5 m	241'0"
<b>J</b> Point Sheave Pitch Diameter	381 cm	150"	381 cm	150"	381 cm	150"

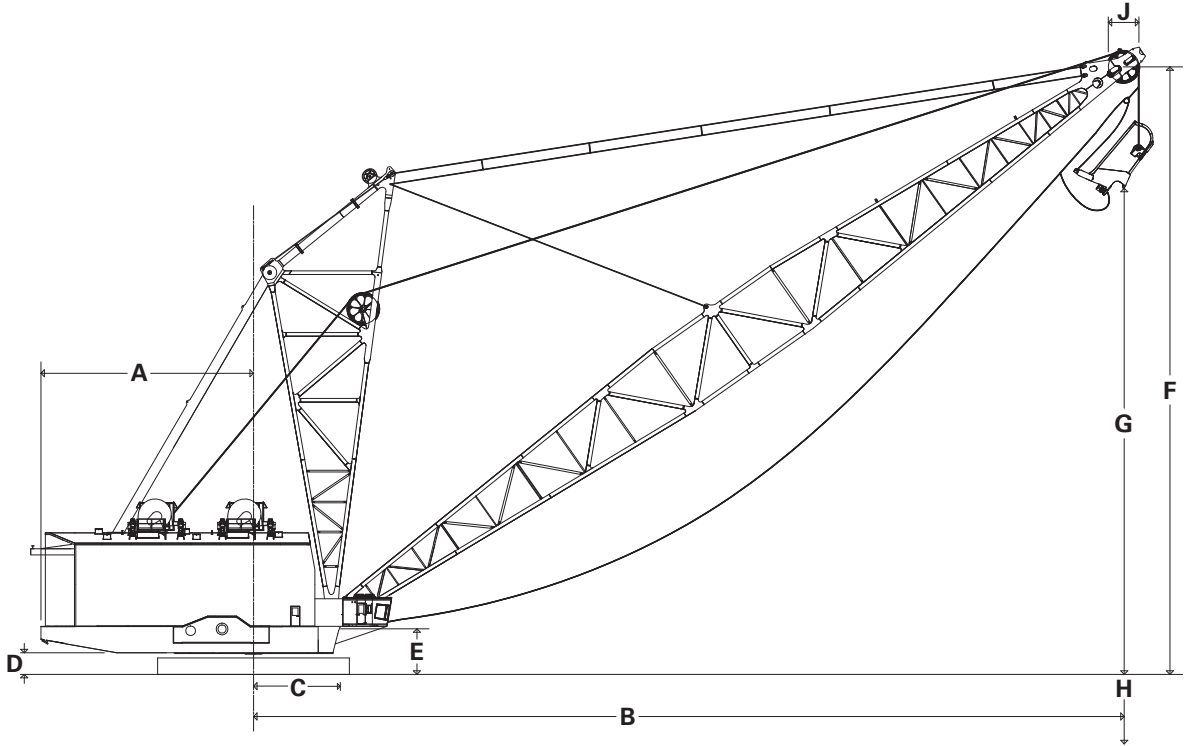

**MODEL**

**8750 – 25.6 m (84'0") Base**

	117.3 m	385'0"	117.3 m	385'0"	117.3 m	385'0"
<b>Boom Length</b>	117.3 m	385'0"	117.3 m	385'0"	117.3 m	385'0"
<b>Boom Angle</b>	39°		35°		32°	
<b>Rated Suspension Load</b>	344 730 kg	760,000 lb	344 730 kg	760,000 lb	283 495 kg	625,000 lb
<b>Dimensions/Working Ranges</b>						
<b>A</b> Clearance Radius	29.26 m	96'0"	29.26 m	96'0"	29.26 m	96'0"
<b>B</b> Operating Radius	100.4 m	329.5'	105.3 m	345.6'	109 m	356.7'
<b>C</b> Boom Foot Radius	7.3 m	24'0"	7.3 m	24'0"	7.3 m	24'0"
<b>D</b> Clearance Height	4.69 m	15'5"	4.69 m	15'5"	4.69 m	15'5"
<b>E</b> Boom Foot Height	6.5 m	21'6"	6.5 m	21'6"	6.5 m	21'6"
<b>F</b> Boom Point Height	80.4 m	263.8'	73.9 m	242.3'	68.7 m	225.5'
<b>G</b> Dumping Height	56.4 m	185'0"	50.0 m	164'0"	47.2 m	155'0"
<b>H</b> Digging Depth	59.4 m	195'0"	65.8 m	216'0"	68.9 m	226'0"
<b>J</b> Point Sheave Pitch Diameter	381 cm	150"	381 cm	150"	381 cm	150"

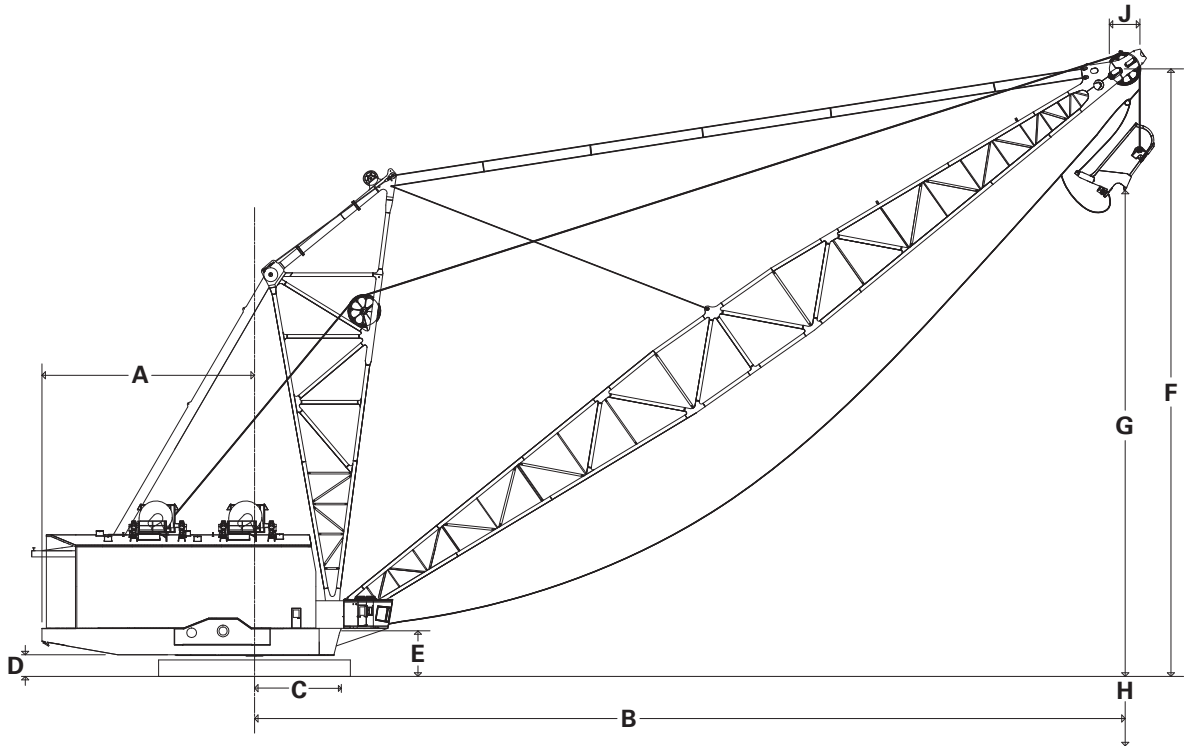

**MODEL**

**8750 – 25.6 m (84'0") Base**

	124.9 m	410'0"	124.9 m	410'0"	124.9 m	410'0"
<b>Boom Length</b>						
<b>Boom Angle</b>	39°		35°		32°	
<b>Rated Suspension Load</b>	306 175 kg	675,000 lb	317 515 kg	700,000 lb	272 155 kg	600,000 lb
<b>Dimensions/Working Ranges</b>						
<b>A</b> Clearance Radius	29.26 m	96'0"	29.26 m	96'0"	29.26 m	96'0"
<b>B</b> Operating Radius	106.3 m	348.9'	111.5 m	366.1'	115.2 m	377.9'
<b>C</b> Boom Foot Radius	7.3 m	24'0"	7.3 m	24'0"	7.3 m	24'0"
<b>D</b> Clearance Height	4.69 m	15'5"	4.69 m	15'5"	4.69 m	15'5"
<b>E</b> Boom Foot Height	6.5 m	21'6"	6.5 m	21'6"	6.5 m	21'6"
<b>F</b> Boom Point Height	85.2 m	279.5'	78.2 m	256.8'	72.8 m	238.9'
<b>G</b> Dumping Height	62.8 m	206'0"	55.2 m	181'0"	51.2 m	168'0"
<b>H</b> Digging Depth	53.0 m	174'0"	60.7 m	199'0"	64.6 m	212'0"
<b>J</b> Point Sheave Pitch Diameter	381 cm	150"	381 cm	150"	381 cm	150"

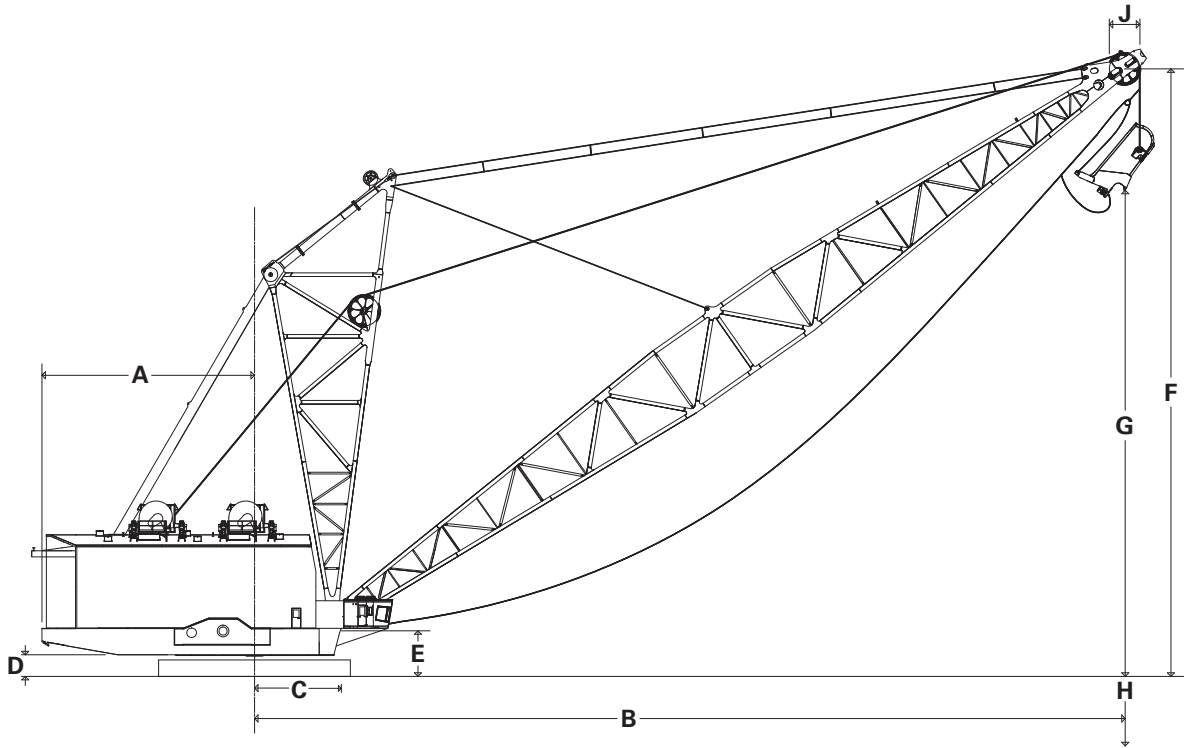

**MODEL**

**8750 – 25.6 m (84'0") Base**

	132.5 m	435'0"	132.5 m	435'0"	132.5 m	435'0"
<b>Boom Length</b>	132.5 m	435'0"	132.5 m	435'0"	132.5 m	435'0"
<b>Boom Angle</b>	39°		35°		32°	
<b>Rated Suspension Load</b>	263 084 kg	580,000 lb	254 012 kg	560,000 lb	240 404 kg	530,000 lb
<b>Dimensions/Working Ranges</b>						
<b>A</b> Clearance Radius	29.26 m	96'0"	29.26 m	96'0"	29.26 m	96'0"
<b>B</b> Operating Radius	112.3 m	368.3'	117.8 m	386.6'	121.6 m	399.2'
<b>C</b> Boom Foot Radius	7.3 m	24'0"	7.3 m	24'0"	7.3 m	24'0"
<b>D</b> Clearance Height	4.69 m	15'5"	4.69 m	15'5"	4.69 m	15'5"
<b>E</b> Boom Foot Height	6.5 m	21'6"	6.5 m	21'6"	6.5 m	21'6"
<b>F</b> Boom Point Height	90 m	295.2'	82.6 m	271.0'	76.8 m	252.0'
<b>G</b> Dumping Height	69.2 m	227'0"	61.9 m	203'0"	56.7 m	186'0"
<b>H</b> Digging Depth	46.9 m	154'0"	54.3 m	178'0"	59.1 m	194'0"
<b>J</b> Point Sheave Pitch Diameter	381 cm	150"	381 cm	150"	381 cm	150"

## 10/10/20 LOAD MANAGEMENT POLICY — DRAGLINES

“Machine overload” shall consist of operating the dragline(s) outside of the acceptable allowable load distribution.

The customer shall be responsible for the monitoring and management of all dragline operational activities, including, but not limited to, management of the machine loading such that its loaded distribution is within the acceptable allowable load distribution.

Operating outside of these parameters over any rolling 30 day period can void the customer’s standard warranty; any extended warranty; any availability guarantee and/or result in adjustments to Caterpillar’s obligations under any contract or agreement.

### Loading Distribution

Loading use over any rolling 30 Day period analyzed:

- No more than 10% of loads should exceed 110% of rated payload.
- No load should exceed 120% of rated payload.
- The average of all loads for the unit must at least equal the rated payload.

### KEY

- 90% of loads should fall into this range.
- No more than 10% of loads should exceed 110% of the target payload.
- No loads should be above 120% of the target payload.

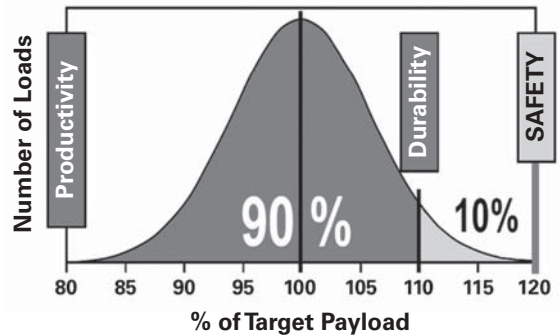

Loading use in excess of this prescribed distribution is considered “machine overload.”

### Notes

- For this policy to be in effect, the “operational cycle” payload feedback must be available to the operator in order that the customer can control actual payloads.
- Customer must procure, install, and use AccessDirect™, MIDAS, and Accuload, and the data must be provided to Caterpillar unmodified and unencumbered.
- Caterpillar must be notified in a timely fashion if the payload monitoring and feedback system is out of service.





# ELECTRIC ROPE SHOVELS

## CONTENTS

### ELECTRIC ROPE SHOVELS

Introduction . . . . .	16-25
Safety and Serviceability . . . . .	16-25
Features . . . . .	16-25
Specifications . . . . .	16-28
Digging Envelopes . . . . .	16-31
General Dimensions . . . . .	16-38
Ground Bearing Pressure . . . . .	16-45
Dipper Selection . . . . .	16-46
Truck Match . . . . .	16-47
Rated Suspended Load . . . . .	16-47
10/10/20 Load Management Policy . . . . .	16-48

## INTRODUCTION

Electric rope shovels are one of the largest loading tools on the market. They run in a truck-shovel operation with mining trucks in order to move large quantities of material at a low cost per ton. Electric rope shovels are used to mine a variety of minerals including oil sands, coal overburden, copper, gold, iron ore, etc. They operate in extreme climates in tough surface mining applications all over the world. With over 85 years' experience in the rope shovel industry, and an active population of nearly 250 machines, Cat Electric Rope Shovels are the most efficient and cost effective loading tools available.

## SAFETY AND SERVICEABILITY

Safety plays an integral role in everything we do at Caterpillar, from our factory floors to our service centers to our clients' mine sites. Caterpillar's commitment to safety is apparent in our product designs, which undergo risk assessments and are designed to meet strict codes and regulations.

Stairways, walkways, platforms and access points are incorporated throughout Cat Electric Rope Shovels to ensure safe and convenient access for maintenance personnel. With safety and serviceability enhancing features incorporated into the operator cab, structures, and electrical equipment, among others, Cat Electric Rope Shovels were designed with safety in mind.

## FEATURES

### AC IGBT Electronics

With over 30 years of AC experience and over 200 operating AC machines, Bucyrus led the industry in AC electric rope shovels. Caterpillar continues to carry on this proud tradition. Since its launch in 1981, the AC electric rope shovel has gained strong industry acceptance, offering:

- **Superior availability:** AC IGBT electric rope shovels have routinely demonstrated electrical availabilities of greater than 98%.
- **Greater reliability:** Fewer components including interchangeable inverters. IGBT systems require no fuses or circuit breakers.
- **Reduced maintenance:** No regular maintenance is required on IGBT power control modules. Motor maintenance on AC machines is reduced to greasing and replacing bearings every 30,000 hours.
- **Durability:** Cat IGBT is a mine quality system with rugged welded cabinets to withstand harsh mining conditions.
- **Reduced inventory:** One IGBT part number is used in multiple locations allowing for decreased component inventory.

### Major Structures

Cat major structures are designed for extended performance in harsh mining conditions. Structures are manufactured using cold-weather, impact-resistant, high-strength steel with select welds of full-penetration, profiled and ground type. All structural welds undergo visual inspection, with critical welds also receiving MT, UT or X-ray inspection. Large furnaces are used to stress-relieve entire weldments for reduced susceptibility to cracking. Interiors of finished structures are painted white to facilitate field inspection.

### Robust Front End Design

The Cat crowd/retract system design presents many benefits over traditional rack-and-pinions systems, including:

- **Fast swing times:** The Cat deck-mounted, rather than boom-mounted, crowd machinery greatly reduces front end weight for reduced swing inertia and fast swing times.
- **Elimination of torsional loading:** The free-floating tubular handle design allows the Cat handle to rotate under uneven loading, transferring force into the ropes rather than into the boom.
- **Superior visibility:** With deck-mounted crowd machinery, Cat machines provide operators with a clear left-hand line of sight for higher visibility and enhanced safety.
- **Efficient digging:** Wide-set boom point sheaves stabilize the dipper as it engages the bank for easier and more efficient digging.

### Cat Cab

Caterpillar's state-of-the-art operator's cab is the product of a multi-year collaboration between Caterpillar, mining companies and shovel operators. The cab provides industry-leading visibility supplemented by five optimally-mounted cameras and display screens. It provides enhanced safety through dual access/egress doors and an optimally-placed trainer seat with independent emergency stop. Additionally, the cab offers the smoothest, most comfortable ride available with an ergonomic, adjustable operator's seat with a fully pneumatic suspension system, low-effort joysticks and dual display screens optimized for operator comfort.

### Power Demand Management System

Caterpillar's exclusive Power Demand Management System for 7495 Series machines allows an electric rope shovel to operate efficiently in spite of electrical infrastructure challenges. This patented energy storage and power management technology reduces the number of generators required to run an electric rope shovel, giving mines the option of production without grid power. Additionally, this technology lowers the machine's peak power requirement, resulting in more alternatives when mines plan for power.

### HydraCrowd™

HydraCrowd represents the first new crowd technology developed in the past 70 years. A hydraulic cylinder inside the tubular dipper handle maintains all the benefits of the Cat front end while eliminating the need for routine crowd/retract rope replacements. HydraCrowd cuts downtime by reducing the number of maintenance events needed to keep the machine operational. HydraCrowd is controlled with proven Cat IGBT technology and has complete diagnostic and troubleshooting information with step-by-step instructions. This technology is currently under a controlled release.

**LatchFree™**

The LatchFree Dipper System is Caterpillar's solution to customers' number one cause of downtime — the traditional latch assembly. The LatchFree dipper eliminates the latch assembly, replacing it with a strong steel link mounted to the dipper back, away from material flow. The system enhances safety by reducing the number of maintenance events required to maintain the system and increases reliability by reducing unplanned downtime. The LatchFree Dipper System comes complete with a comprehensive training program to ensure customers achieve maximum system benefits, and is currently under a controlled release.

**FastFil™ Dipper Design**

The unique FastFil dipper provides customers with faster and fuller dipper loads where the application permits. Its trapezoidal shape accommodates the natural configuration of the load, eliminating voids that occur with box-shaped dippers for improved fill factors. The trapezoidal shape also optimizes dipper size and weight for improved maneuverability and faster swing times. Additionally, an adjustable pitch brace allows rake angle changes to improve bank penetration, eliminate bulldozing, and improve productivity. Combined, the FastFil features maximize the fill factor.

**Operator Assist — Enhanced Motion Control**

The operator assist — enhanced motion control system eliminates or reduces the occurrence of crowd over-speeds, crowd impacts, hoist stalls, boom jacking, and swinging while engaged in the bank. This is accomplished by intelligently controlling how motions are allowed to operate under certain conditions. The reduced system stress and equal or better cycle times improve shovel performance and cost per ton. This software is standard on all 7495 Series electric rope shovels.

**AccessDirect**

AccessDirect is an electrical interface system that facilitates remote access to a machine's onboard computer via the Internet. With AccessDirect, maintenance personnel can analyze faults from off-site locations and arrive on-site prepared to resolve issues, leading to reduced machine downtime. AccessDirect also enables factory experts to remotely access and troubleshoot faults, resulting in superior response times and reduced mean time to repair.

**AccuLoad**

AccuLoad is a data analysis system that provides real-time feedback on dipper loads. AccuLoad's payload calculation is accomplished without mechanical sensors, eliminating the need for recalibration, which is a common problem with other load weighing systems. The system can be employed to calculate material moved, to monitor overloading of trucks, or to allow operators to study their loading efficiency and shift performance. It can also log operator performance data which, when paired with MIDAS, can generate reports to help identify training opportunities to increase shift production.

**MIDAS**

The MIDAS health monitoring system continues to optimize machine performance by providing, logging and analyzing data on a variety of machine variables. MIDAS comes complete with a built-in report generator that outputs data in a format that can be easily analyzed to identify opportunities to improve machine performance. When paired with AccessDirect and AccuLoad, MIDAS provides real-time monitoring of shovel operation and provides users with a 3D model to watch the shovel in motion.

<b>MODEL</b>	<b>7295</b>		<b>7395</b>	
Payload	45 tonnes	<b>50 tons</b>	64 tonnes	<b>70 tons</b>
Operating Weight	793 259 kg*	<b>1,748,837 lb*</b>	1 202 927 kg**	<b>2,652,000 lb**</b>
Dipper Range	19.1-38.2 m <sup>3</sup>	<b>25-50 yd<sup>3</sup></b>	20.5-55.8 m <sup>3</sup>	<b>27-73 yd<sup>3</sup></b>
Drive	<b>AC IGBT</b>		<b>AC IGBT</b>	
Distribution System Requirements (separate system)	<b>2000 kVA</b>		<b>3500 kVA</b>	
Distribution System Requirements (large system)	<b>1320 kVA</b>		<b>2000 kVA</b>	
Average 15 Minute Demand	<b>538-753 kW</b>		<b>777-1087 kW</b>	
Peak Power	<b>2152 kW</b>		<b>3106 kW</b>	
Crowd Type	<b>Tubular handle rope crowd</b>		<b>Tubular handle rope crowd</b>	
Hoist Ropes				
Number	<b>2</b>		<b>2</b>	
Diameter	57 mm	<b>2¼"</b>	70 mm	<b>2¾"</b>
Type	<b>Twin dual</b>		<b>Twin dual</b>	
Construction	<b>8 strand</b>		<b>8 strand</b>	
Crowd/Retract Ropes				
Number	<b>1 crowd, 1 retract</b>		<b>1 crowd, 1 retract</b>	
Diameter	60 mm	<b>2¾"</b>	64 mm	<b>2½"</b>
Type	<b>Single dual</b>		<b>Single dual</b>	
Construction	<b>8 strand</b>		<b>8 strand</b>	

\*Based on a 19 m<sup>3</sup> (**25 yd<sup>3</sup>**) dipper.

\*\*Based on a 24 m<sup>3</sup> (**32 yd<sup>3</sup>**) dipper.

Information subject to change.

<b>MODEL</b>	<b>7495 HD</b>		<b>7495</b>		<b>7495 HydraCrowd</b>	
Payload	82 tonnes	<b>90 tons</b>	109 tonnes	<b>120 tons</b>	109 tonnes	<b>120 tons</b>
Operating Weight	1 295 777 kg*	<b>2,856,700 lb*</b>	1 386 178 kg**	<b>3,056,000 lb**</b>	1 390 714 kg***	<b>3,066,000 lb***</b>
Dipper Range	27.5-60.4 m <sup>3</sup>	<b>36-79 yd<sup>3</sup></b>	30.6-62.7 m <sup>3</sup>	<b>40-82 yd<sup>3</sup></b>	30.6-62.7 m <sup>3</sup>	<b>40-82 yd<sup>3</sup></b>
Drive	<b>AC IGBT</b>		<b>AC IGBT</b>		<b>AC IGBT</b>	
Distribution System Requirements (separate system)	<b>3500 kVA</b>		<b>4000 kVA</b>		<b>4000 kVA</b>	
Distribution System Requirements (large system)	<b>2000 kVA</b>		<b>2080 kVA</b>		<b>2120 kVA</b>	
Average 15 Minute Demand	<b>832-1165 kW</b>		<b>934-1308 kW</b>		<b>945-1322 kW</b>	
Peak Power	<b>3330 kW</b>		<b>3737 kW</b>		<b>3778 kW</b>	
Crowd Type	<b>Tubular handle rope crowd</b>		<b>Tubular handle rope crowd</b>		<b>Tubular handle HydraCrowd</b>	
Hoist Ropes	<b>2</b>		<b>2</b>		<b>2</b>	
Number	<b>2</b>		<b>2</b>		<b>2</b>	
Diameter	70 mm	<b>2¾"</b>	70 mm	<b>2¾"</b>	70 mm	<b>2¾"</b>
Type	<b>Twin dual</b>		<b>Twin dual</b>		<b>Twin dual</b>	
Construction	<b>8 strand</b>		<b>8 strand</b>		<b>8 strand</b>	
Crowd/Retract Ropes	<b>1 crowd, 1 retract</b>		<b>1 crowd, 1 retract</b>		<b>N/A</b>	
Number	<b>1 crowd, 1 retract</b>		<b>1 crowd, 1 retract</b>		<b>N/A</b>	
Diameter	64 mm	<b>2.5"</b>	64 mm	<b>2.5"</b>	<b>N/A</b>	
Type	<b>Single dual</b>		<b>Single dual</b>		<b>N/A</b>	
Construction	<b>8 strand</b>		<b>8 strand</b>		<b>N/A</b>	

\*Based on 32 m<sup>3</sup> (**42 yd<sup>3</sup>**) dipper.

\*\*Based on 55.8 m<sup>3</sup> (**73 yd<sup>3</sup>**) dipper.

\*\*\*Based on 45.1 m<sup>3</sup> (**59 yd<sup>3</sup>**) LatchFree dipper.

N/A = Not Available.

Information subject to change.

<b>MODEL</b>	<b>7495 HF</b>		<b>7495 HF HydraCrowd</b>	
Payload	109 tonnes	<b>120 tons</b>	109 tonnes	<b>120 tons</b>
Operating Weight	1 431 064 kg*	<b>3,155,000 lb*</b>	1 435 166 kg**	<b>3,164,000 lb**</b>
Dipper Range	30.6-62.7 m <sup>3</sup>	<b>40-82 yd<sup>3</sup></b>	30.6-62.7 m <sup>3</sup>	<b>40-82 yd<sup>3</sup></b>
Drive	<b>AC IGBT</b>		<b>AC IGBT</b>	
Distribution System Requirements (separate system)	<b>4000 kVA</b>		<b>4000 kVA</b>	
Distribution System Requirements (large system)	<b>2080 kVA</b>		<b>2120 kVA</b>	
Average 15 Minute Demand	<b>934-1308 kW</b>		<b>945-1322 kW</b>	
Peak Power	<b>3737 kW</b>		<b>3778 kW</b>	
Crowd Type	<b>Tubular handle rope crowd</b>		<b>Tubular handle HydraCrowd</b>	
Hoist Ropes				
Number	<b>2</b>		<b>2</b>	
Diameter	70 mm	<b>2¾"</b>	70 mm	<b>2¾"</b>
Type	<b>Twin dual</b>		<b>Twin dual</b>	
Construction	<b>8 strand</b>		<b>8 strand</b>	
Crowd/Retract Ropes				
Number	<b>1 crowd, 1 retract</b>		<b>N/A</b>	
Diameter	64 mm	<b>2½"</b>	<b>N/A</b>	
Type	<b>Single dual</b>		<b>N/A</b>	
Construction	<b>8 strand</b>		<b>N/A</b>	

\*Based on 55.8 m<sup>3</sup> (**73 yd<sup>3</sup>**) dipper.

\*\*Based on 45.1 m<sup>3</sup> (**59 yd<sup>3</sup>**) LatchFree dipper.

N/A = Not Available.

Information subject to change.

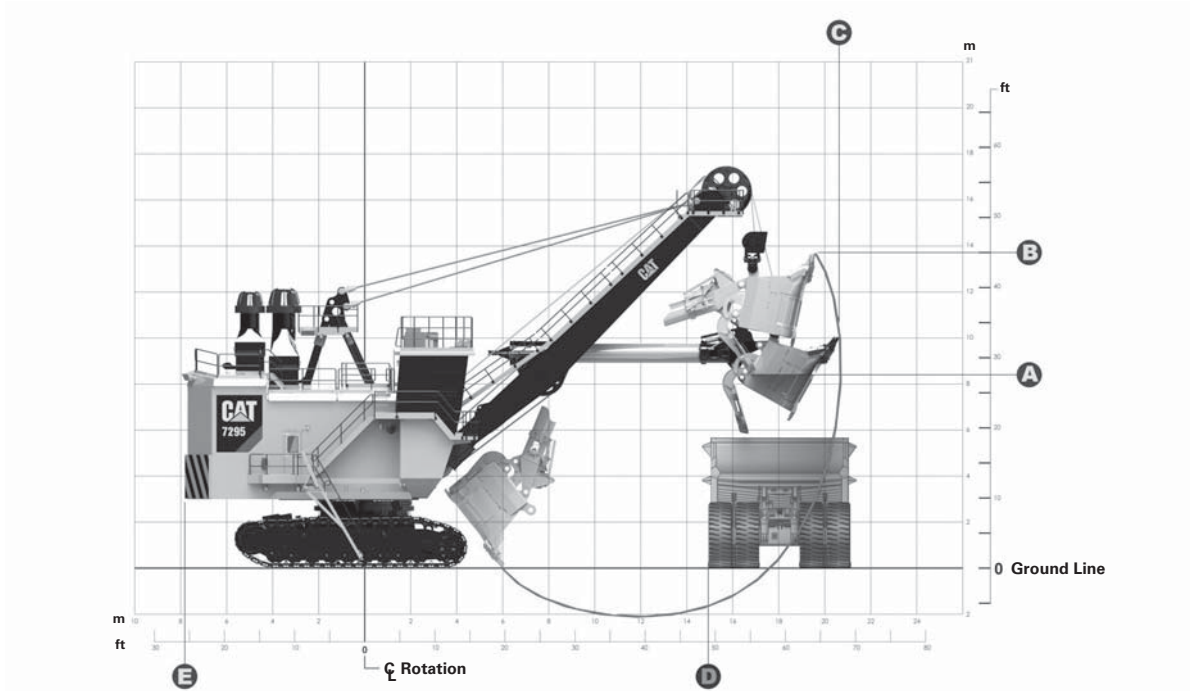

**MODEL**

**7295**

<b>A</b> Dumping Height with Clearance to Open Dipper Door	8.40 m	27'8"
<b>B</b> Cutting Height (maximum)	13.70 m	45'0"
<b>C</b> Cutting Radius (maximum)	20.60 m	67'8"
<b>D</b> Radius of Level Floor	14.90 m	48'11"
<b>E</b> Revolving Frame Tail Swing Radius	7.80 m	25'8"

Specifications are based on a 19 m<sup>3</sup> (25 yd<sup>3</sup>) dipper with standard 182.9 cm (72 in) treads, loading a Cat 785D truck.  
Information subject to change.  
All dimensions are approximate and will vary depending on dipper size.



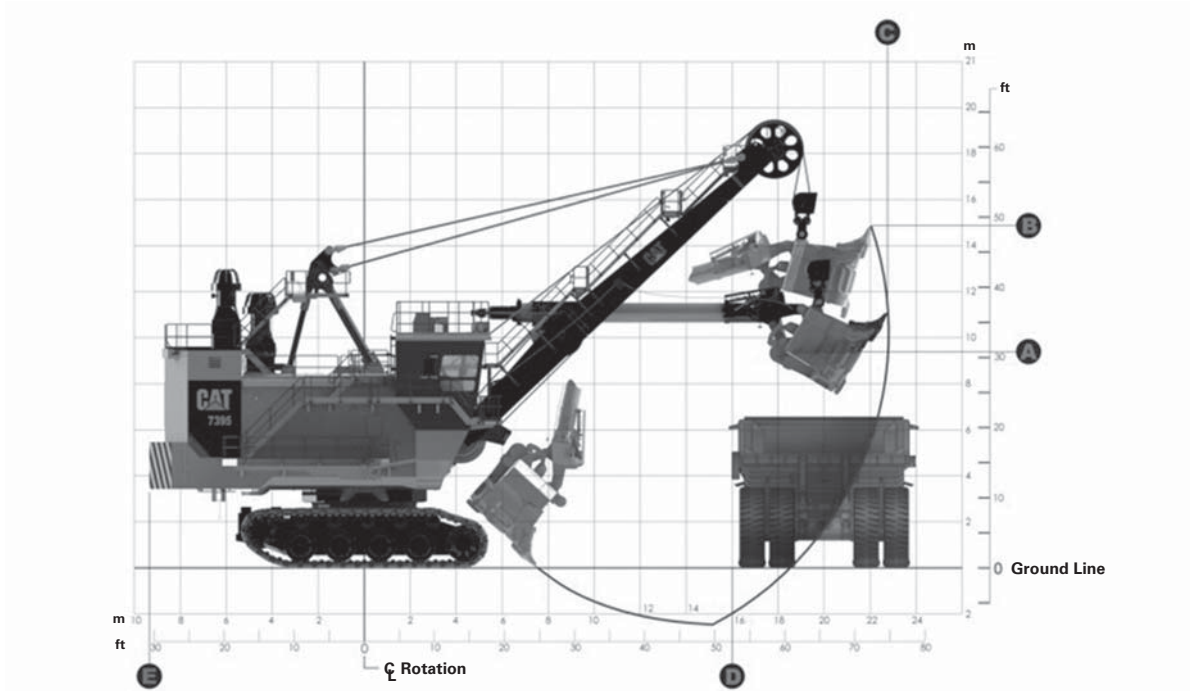

**MODEL**

**7395**

<b>A</b> Dumping Height with Clearance to Open Dipper Door	9.40 m	<b>30'10"</b>
<b>B</b> Cutting Height (maximum)	14.90 m	<b>48'9"</b>
<b>C</b> Cutting Radius (maximum)	22.80 m	<b>74'9"</b>
<b>D</b> Radius of Level Floor	16.00 m	<b>52'4"</b>
<b>E</b> Revolving Frame Tail Swing Radius	9.30 m	<b>30'8"</b>

Specifications are based on a 32 m<sup>3</sup> (42 yd<sup>3</sup>) dipper with standard 213.4 cm (84 in) treads, loading a Cat 793F truck.  
Information subject to change.  
All dimensions are approximate and will vary depending on dipper size.

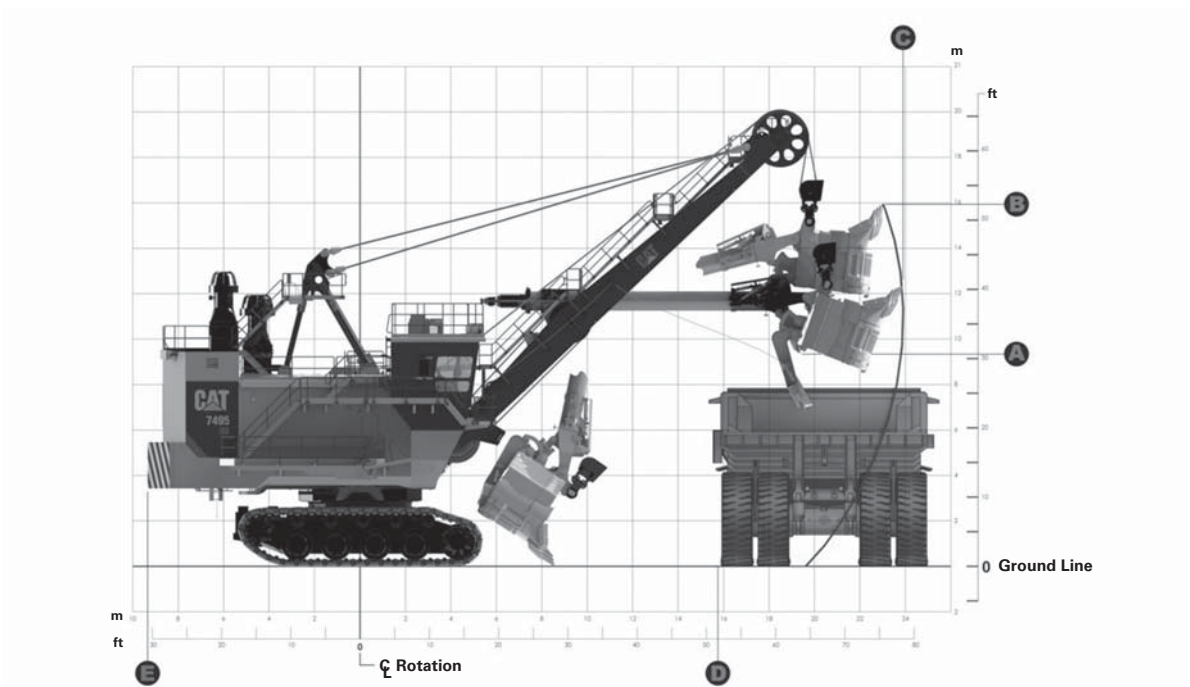

**MODEL**

**7495 HD**

<b>A</b> Dumping Height with Clearance to Open Dipper Door	9.40 m	30'9"
<b>B</b> Cutting Height (maximum)	16.00 m	52'4"
<b>C</b> Cutting Radius (maximum)	23.90 m	78'5"
<b>D</b> Radius of Level Floor	15.70 m	51'8"
<b>E</b> Revolving Frame Tail Swing Radius	9.30 m	30'8"

Specifications are based on a 32 m<sup>3</sup> (42 yd<sup>3</sup>) dipper with standard 213.4 cm (84 in) treads, loading a Cat 793F truck.  
Information subject to change.  
All dimensions are approximate and will vary depending on dipper size.

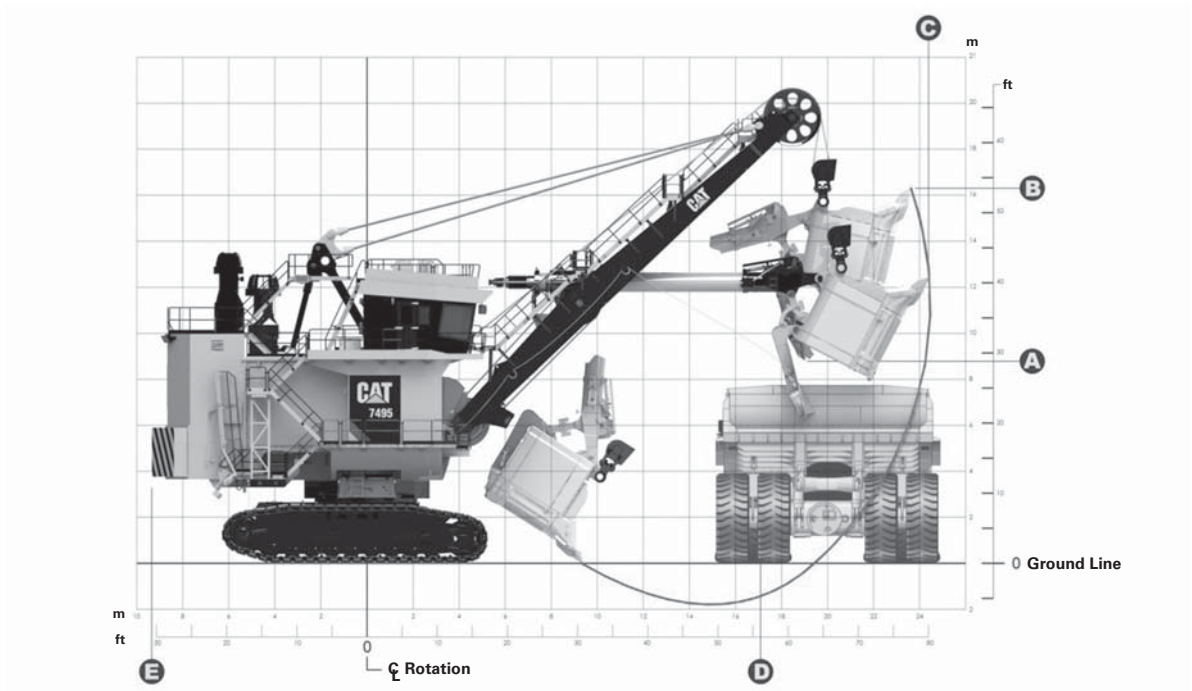

**MODEL**

**7495**

<b>A</b> Dumping Height with Clearance to Open Dipper Door	8.80 m	<b>28'11"</b>
<b>B</b> Cutting Height (maximum)	16.30 m	<b>53'6"</b>
<b>C</b> Cutting Radius (maximum)	24.40 m	<b>80'0"</b>
<b>D</b> Radius of Level Floor	17.10 m	<b>56'1"</b>
<b>E</b> Revolving Frame Tail Swing Radius	9.30 m	<b>30'8"</b>

Specifications are based on a 56 m<sup>3</sup> (73 yd<sup>3</sup>) dipper with standard 200.7 cm (79 in) treads, loading a Cat 797F truck.  
Information subject to change.  
All dimensions are approximate and will vary depending on dipper size.

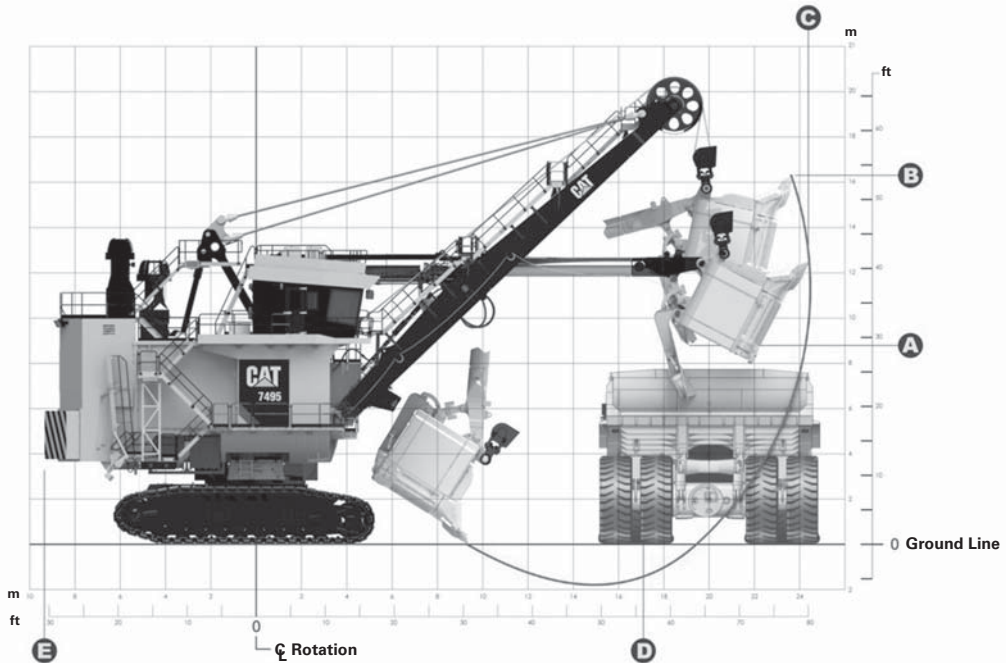

**MODEL**

**7495 HydraCrowd**

<b>A</b> Dumping Height with Clearance to Open Dipper Door	8.80 m	<b>28'11"</b>
<b>B</b> Cutting Height (maximum)	16.30 m	<b>53'6"</b>
<b>C</b> Cutting Radius (maximum)	24.40 m	<b>80'0"</b>
<b>D</b> Radius of Level Floor	17.10 m	<b>56'1"</b>
<b>E</b> Revolving Frame Tail Swing Radius	9.30 m	<b>30'8"</b>

Specifications are based on a 56 m<sup>3</sup> (73 yd<sup>3</sup>) dipper with standard 200.7 cm (79 in) treads, loading a Cat 795F AC truck.  
 Information subject to change.  
 All dimensions are approximate and will vary depending on dipper size.

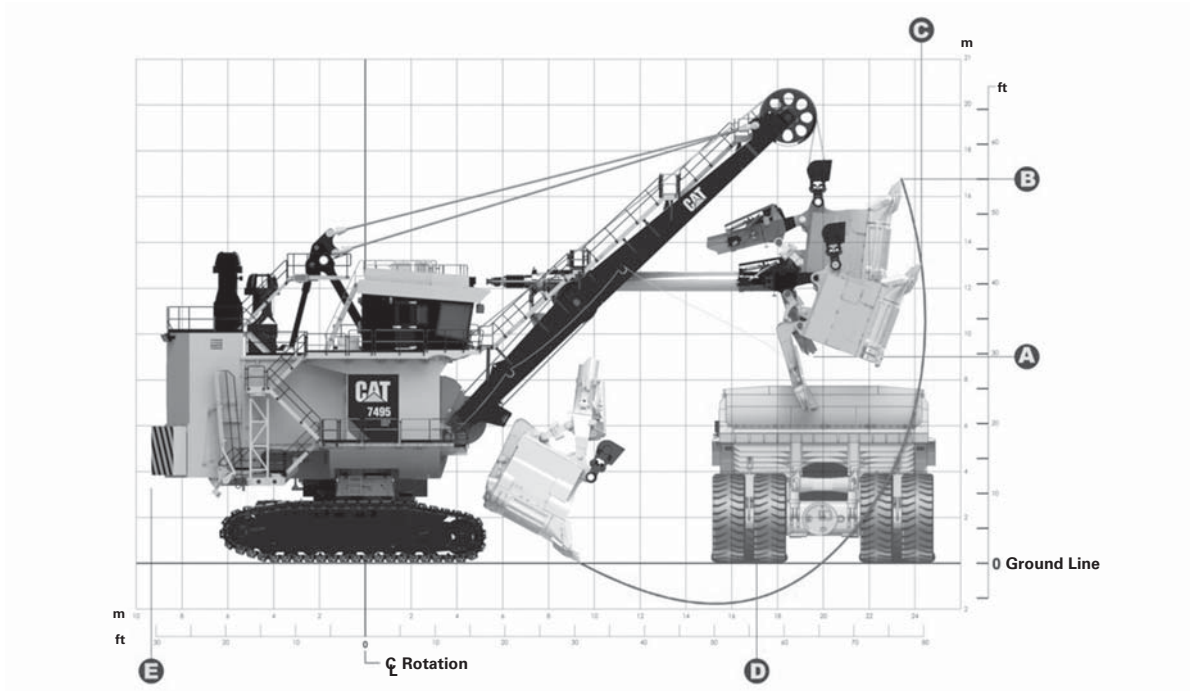

**MODEL**

**7495 HF**

<b>A</b> Dumping Height with Clearance to Open Dipper Door	9.00 m	29'8"
<b>B</b> Cutting Height (maximum)	16.80 m	55'0"
<b>C</b> Cutting Radius (maximum)	24.30 m	79'8"
<b>D</b> Radius of Level Floor	17.00 m	55'11"
<b>E</b> Revolving Frame Tail Swing Radius	9.30 m	30'8"

Specifications are based on a 45 m<sup>3</sup> (59 yd<sup>3</sup>) dipper with standard 317.5 cm (125 in) treads, loading a Cat 797F truck.  
Information subject to change.  
All dimensions are approximate and will vary depending on dipper size.

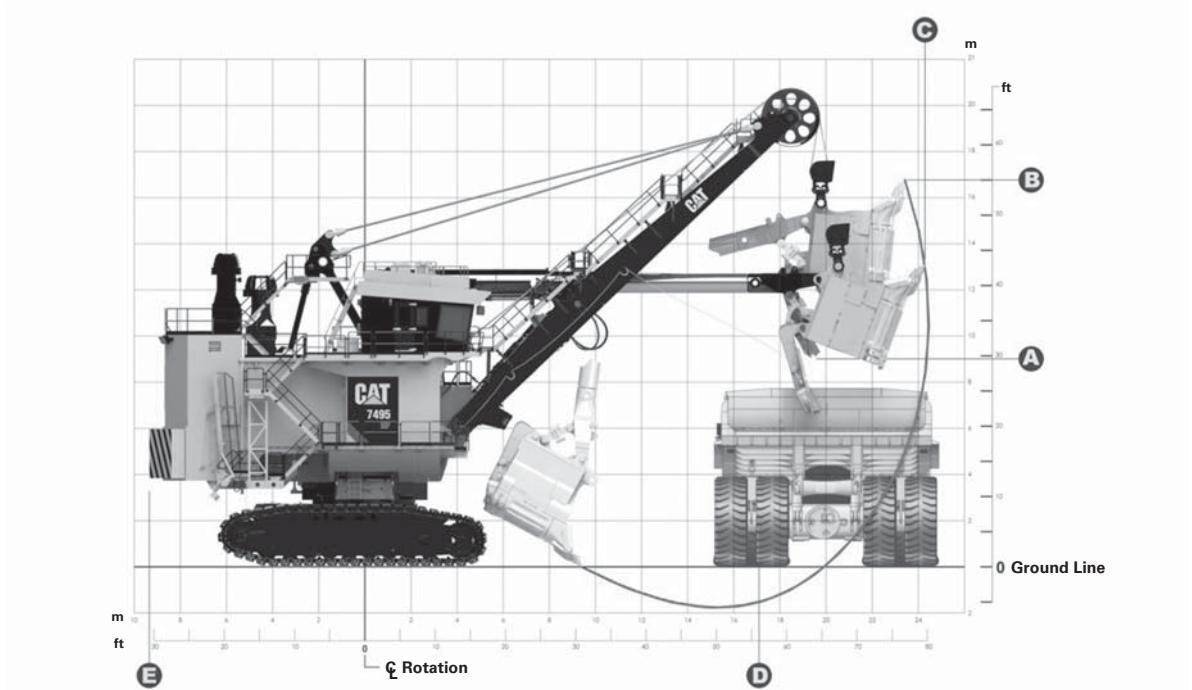

**MODEL**

**7495 HF HydraCrowd**

<b>A</b> Dumping Height with Clearance to Open Dipper Door	9.00 m	29'8"
<b>B</b> Cutting Height (maximum)	16.80 m	55'0"
<b>C</b> Cutting Radius (maximum)	24.30 m	79'8"
<b>D</b> Radius of Level Floor	17.00 m	55'11"
<b>E</b> Revolving Frame Tail Swing Radius	9.30 m	30'8"

Specifications are based on a 45 m<sup>3</sup> (59 yd<sup>3</sup>) dipper with standard 317.5 cm (125 in) treads, loading a Cat 797F truck.  
 Information subject to change.  
 All dimensions are approximate and will vary depending on dipper size.

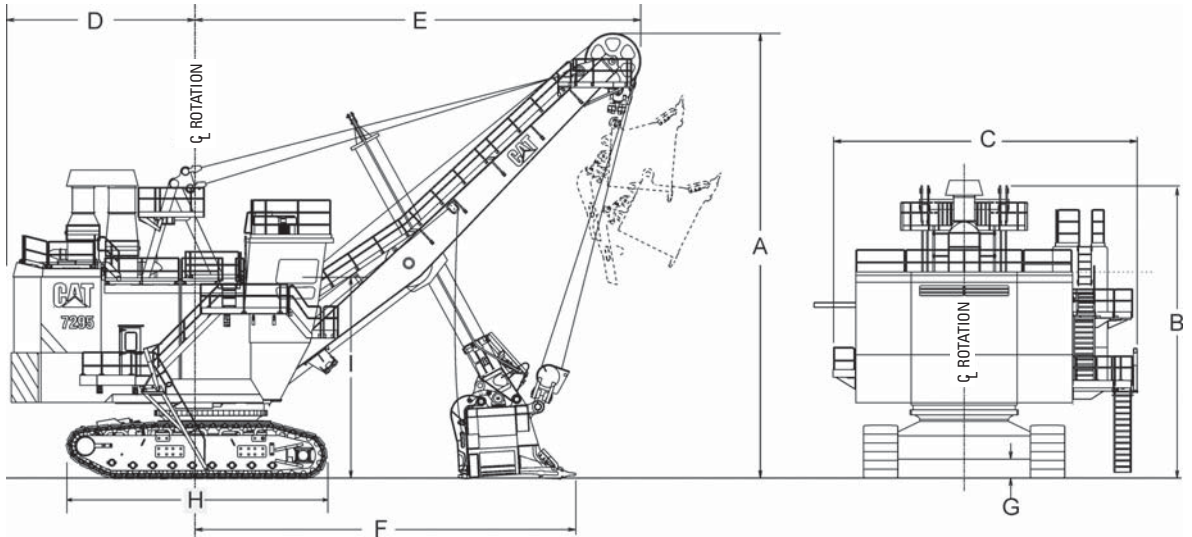

**MODEL**

**7295**

MODEL	7295	
<b>Boom Length</b>	18.00 m	59'0"
<b>A</b> Height	18.15 m	59'7"
<b>B</b> A-Frame Height	11.94 m	39'2"
<b>C</b> Overall Width	12.39 m	40'8"
<b>D</b> Tail Swing Radius	7.80 m	25'8"
<b>E</b> Clearance Radius	17.48 m	57'4"
<b>F</b> Radius of Level Floor*	14.90 m	48'11"
<b>G</b> Minimum Ground Clearance	0.78 m	2'6"
<b>H</b> Track Length	10.26 m	33'8"
<b>I</b> Operator Eye Level	8.20 m	26'11"

\*Dimensions based on 19 m<sup>3</sup> (25 yd<sup>3</sup>) dipper.

Information subject to change.

All dimensions are approximate and will vary depending on dipper size.

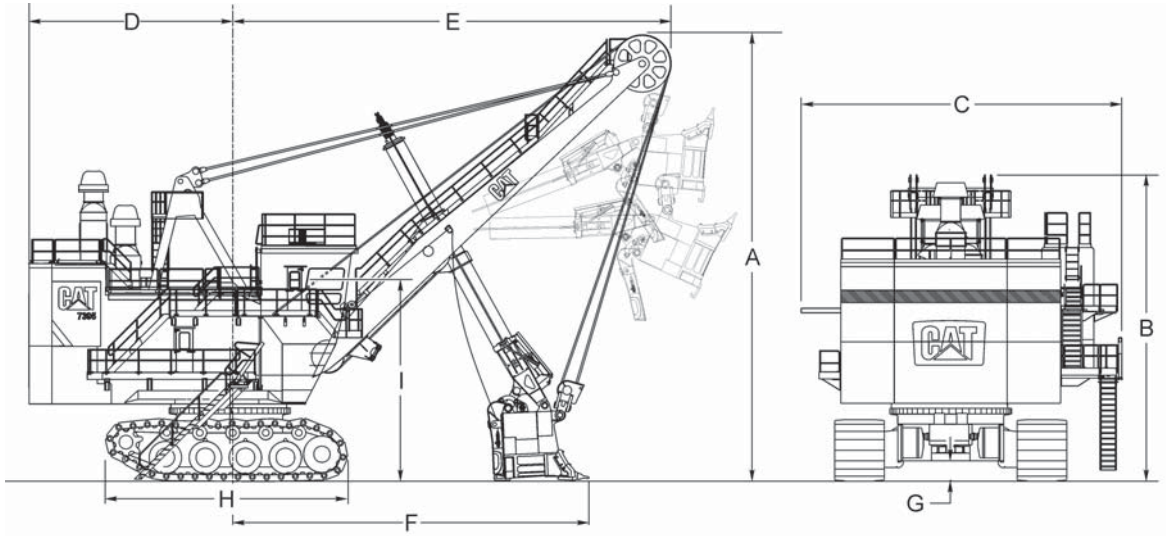

**MODEL**

**7395**

MODEL	7395	
<b>Boom Length</b>	19.51 m	64'0"
<b>A</b> Height	19.50 m	63'11"
<b>B</b> A-Frame Height	13.30 m	43'8"
<b>C</b> Overall Width	13.01 m	42'8"
<b>D</b> Tail Swing Radius	9.30 m	30'8"
<b>E</b> Clearance Radius	19.05 m	62'6"
<b>F</b> Radius of Level Floor*	16.00 m	52'4"
<b>G</b> Minimum Ground Clearance	0.86 m	2'10"
<b>H</b> Track Length	10.41 m	34'2"
<b>I</b> Operator Eye Level	8.64 m	28'4"

\*Dimensions based on 24 m<sup>3</sup> (32 yd<sup>3</sup>) dipper.

Information subject to change.

All dimensions are approximate and will vary depending on dipper size.



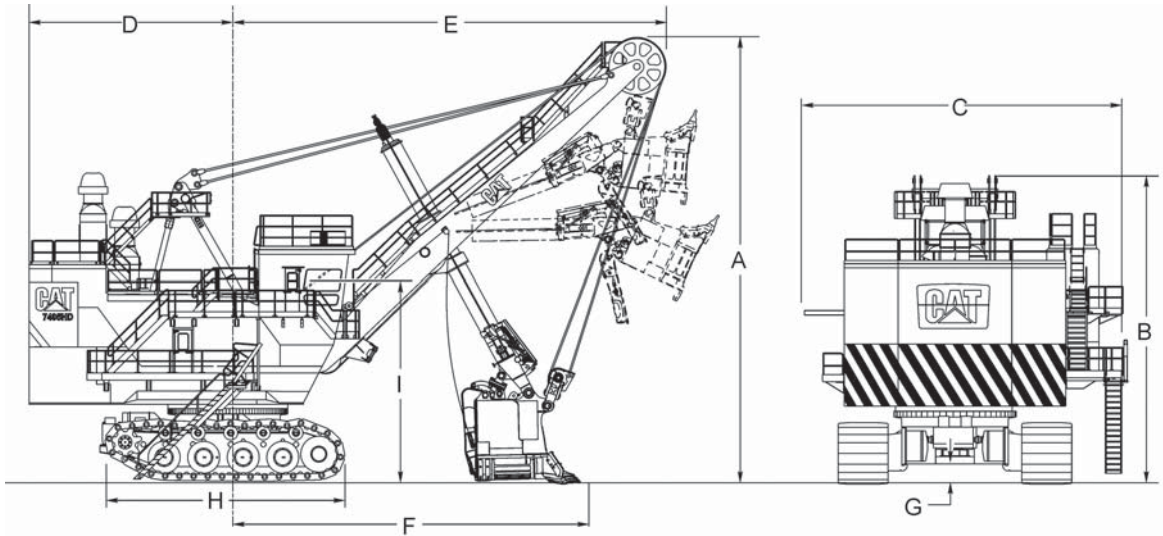

**MODEL**

**7495 HD**

MODEL	7495 HD	
<b>Boom Length</b>	20.40 m	67'0"
<b>A</b> Height	20.10 m	65'10"
<b>B</b> A-Frame Height	13.30 m	43'8"
<b>C</b> Overall Width	13.01 m	42'8"
<b>D</b> Tail Swing Radius	9.30 m	30'8"
<b>E</b> Clearance Radius	19.74 m	64'9"
<b>F</b> Radius of Level Floor*	15.70 m	51'8"
<b>G</b> Minimum Ground Clearance	0.86 m	2'10"
<b>H</b> Track Length	10.41 m	34'2"
<b>I</b> Operator Eye Level	8.64 m	28'4"

\*Dimensions based on 32 m<sup>3</sup> (42 yd<sup>3</sup>) dipper.

Information subject to change.

All dimensions are approximate and will vary depending on dipper size.

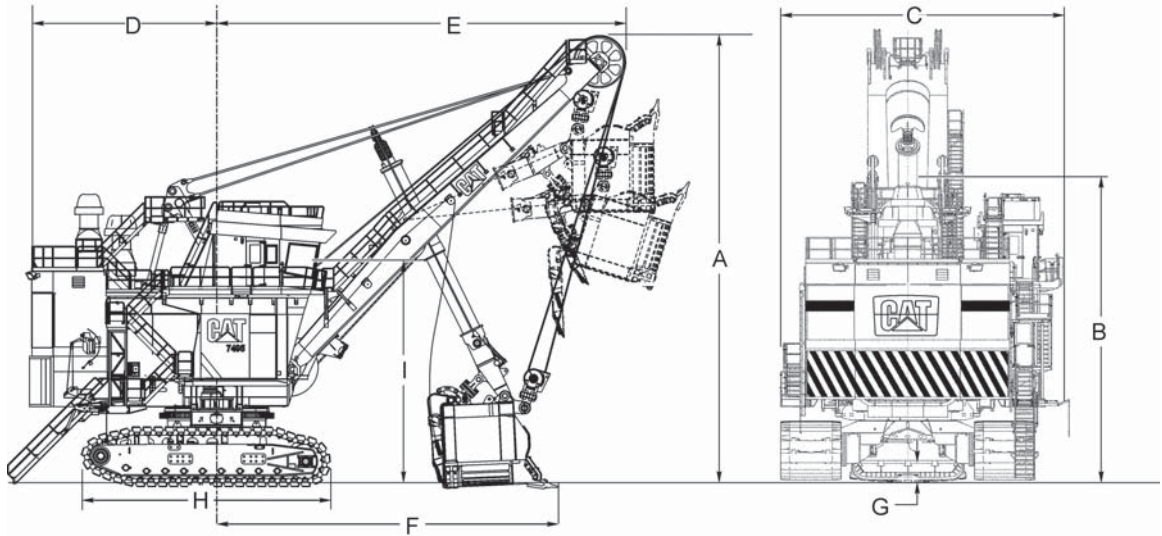

**MODEL**

**7495**

MODEL	7495	
<b>Boom Length</b>	20.40 m	67'0"
<b>A</b> Height	20.87 m	68'6"
<b>B</b> A-Frame Height	14.00 m	46'0"
<b>C</b> Overall Width	13.11 m	43'0"
<b>D</b> Tail Swing Radius	9.30 m	30'8"
<b>E</b> Clearance Radius	19.65 m	64'5"
<b>F</b> Radius of Level Floor*	17.10 m	56'1"
<b>G</b> Minimum Ground Clearance	0.90 m	3'0"
<b>H</b> Track Length	11.43 m	37'6"
<b>I</b> Operator Eye Level	10.61 m	34'10"

\*Dimensions based on 56 m<sup>3</sup> (73 yd<sup>3</sup>) dipper.

Information subject to change.

All dimensions are approximate and will vary depending on dipper size.

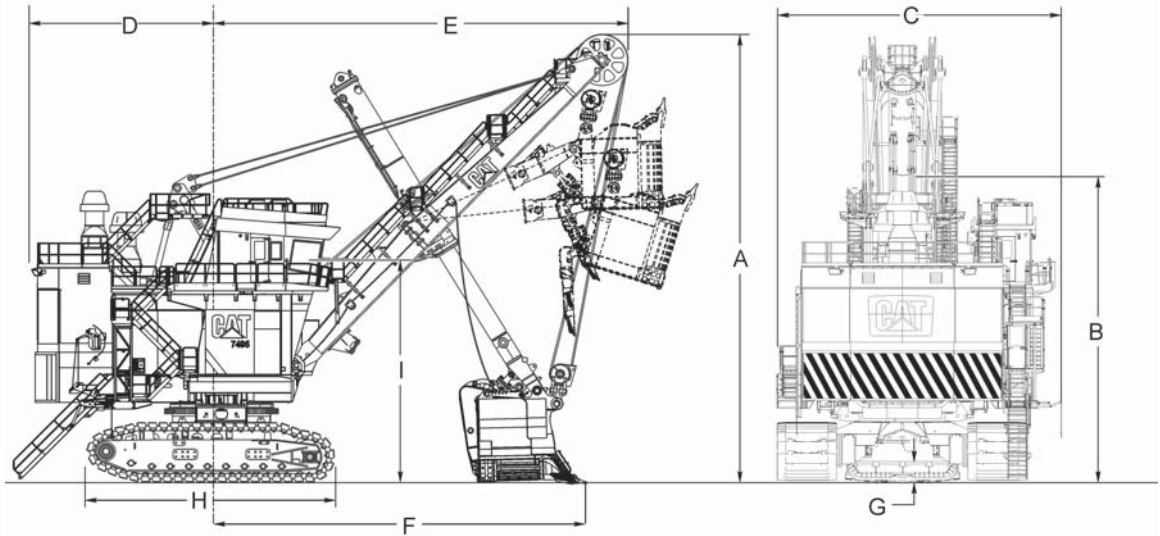

**MODEL**

**7495 HydraCrowd**

MODEL	7495 HydraCrowd	
<b>Boom Length</b>	20.40 m	<b>67'0"</b>
<b>A</b> Height	20.87 m	<b>68'6"</b>
<b>B</b> A-Frame Height	14.00 m	<b>46'0"</b>
<b>C</b> Overall Width	13.11 m	<b>43'0"</b>
<b>D</b> Tail Swing Radius	9.30 m	<b>30'8"</b>
<b>E</b> Clearance Radius	19.65 m	<b>64'5"</b>
<b>F</b> Radius of Level Floor*	17.10 m	<b>56'1"</b>
<b>G</b> Minimum Ground Clearance	0.90 m	<b>3'0"</b>
<b>H</b> Track Length	11.43 m	<b>37'6"</b>
<b>I</b> Operator Eye Level	10.61 m	<b>34'10"</b>

\*Dimensions based on 56 m<sup>3</sup> (73 yd<sup>3</sup>) dipper.

Information subject to change.

All dimensions are approximate and will vary depending on dipper size.

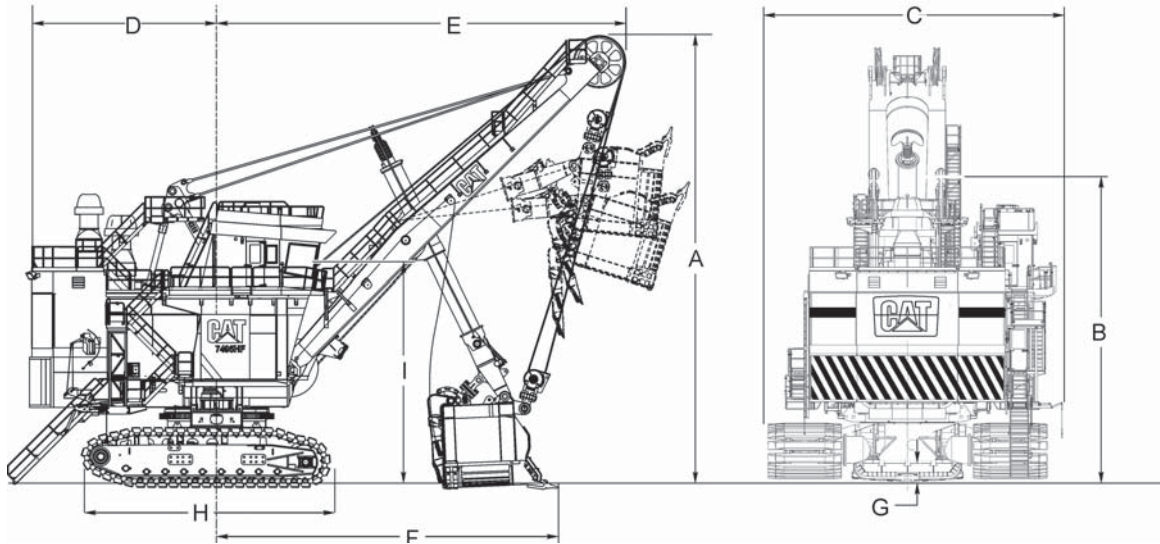

**MODEL**

**7495 HF**

MODEL	7495 HF	
<b>Boom Length</b>	20.40 m	<b>67'0"</b>
<b>A</b> Height	20.87 m	<b>68'6"</b>
<b>B</b> A-Frame Height	14.00 m	<b>46'0"</b>
<b>C</b> Overall Width	13.96 m	<b>46'1"</b>
<b>D</b> Tail Swing Radius	9.30 m	<b>30'8"</b>
<b>E</b> Clearance Radius	19.65 m	<b>64'5"</b>
<b>F</b> Radius of Level Floor*	17.00 m	<b>55'11"</b>
<b>G</b> Minimum Ground Clearance	0.90 m	<b>3'0"</b>
<b>H</b> Track Length	11.43 m	<b>37'6"</b>
<b>I</b> Operator Eye Level	10.61 m	<b>34'10"</b>

\*Dimensions based on 45 m<sup>3</sup> (59 yd<sup>3</sup>) dipper.

Information subject to change.

All dimensions are approximate and will vary depending on dipper size.

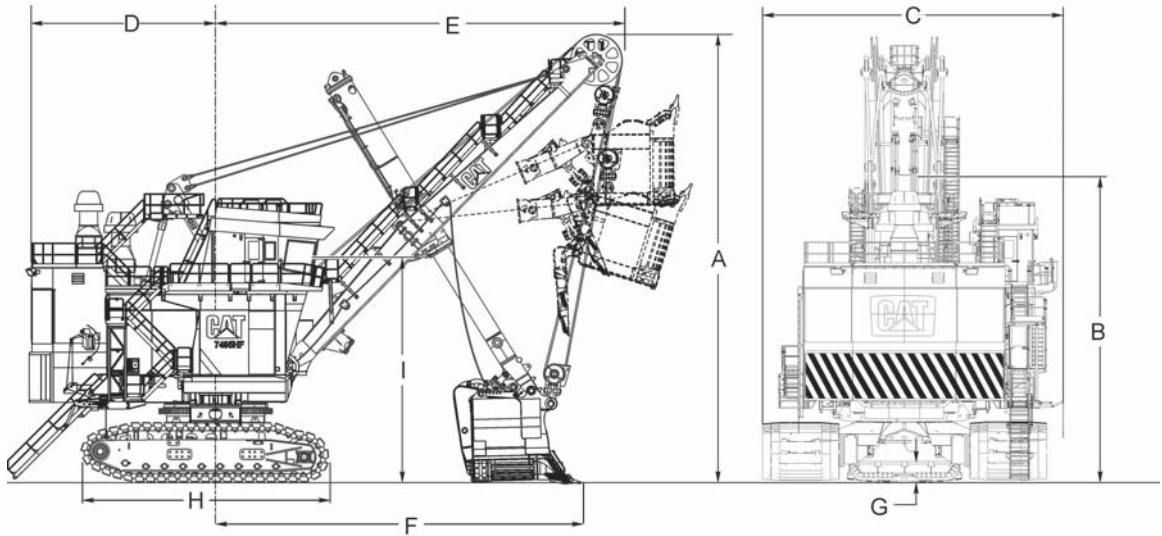

**MODEL**

**7495 HF HydraCrowd**

MODEL	7495 HF HydraCrowd	
<b>Boom Length</b>	20.40 m	<b>67'0"</b>
<b>A</b> Height	20.87 m	<b>68'6"</b>
<b>B</b> A-Frame Height	14.00 m	<b>46'0"</b>
<b>C</b> Overall Width	13.96 m	<b>46'1"</b>
<b>D</b> Tail Swing Radius	9.30 m	<b>30'8"</b>
<b>E</b> Clearance Radius	19.65 m	<b>64'5"</b>
<b>F</b> Radius of Level Floor*	17.00 m	<b>55'11"</b>
<b>G</b> Minimum Ground Clearance	0.90 m	<b>3'0"</b>
<b>H</b> Track Length	11.43 m	<b>37'6"</b>
<b>I</b> Operator Eye Level	10.61 m	<b>34'10"</b>

\*Dimensions based on 45 m<sup>3</sup> (59 yd<sup>3</sup>) dipper.  
Information subject to change.  
All dimensions are approximate and will vary depending on dipper size.

**GROUND BEARING PRESSURE**

Ground bearing pressure, or the amount of weight that can be supported by ground conditions, determines the link width (and occasionally the machine model) that can be used at a mine site. Softer ground conditions require wider links while the softest conditions (i.e. oil sands) require a specific model (7495 HF) which was

designed to operate under low ground bearing pressure conditions. A link too narrow for the application may even cause the crawlers to sink into the ground.

The chart below lists the link length options for each electric rope shovel model as well as the corresponding minimum ground bearing pressures.

<b>MODEL</b>	<b>7295<sup>1</sup></b>		<b>7395<sup>2</sup></b>		<b>7495 HD<sup>3</sup></b>		<b>7495<sup>4</sup></b>	
Standard Link Length	183 cm	<b>72"</b>	213 cm	<b>84"</b>	213 cm	<b>84"</b>	200 cm	<b>79"</b>
Ground Bearing Pressure	269 kPa	<b>39 psi</b>	371 kPa	<b>54 psi</b>	400 kPa	<b>58 psi</b>	380 kPa	<b>55 psi</b>
Optional Link Length	—		274 cm	<b>108"</b>	274 cm	<b>108"</b>	259 cm	<b>102"</b>
Ground Bearing Pressure	—		276 kPa	<b>43 psi</b>	316 kPa	<b>46 psi</b>	297 kPa	<b>43 psi</b>

<b>MODEL</b>	<b>7495 HydraCrowd<sup>4</sup></b>		<b>7495 HF<sup>5</sup></b>		<b>7495 HF HydraCrowd<sup>5</sup></b>	
Standard Link Length	200 cm	<b>79"</b>	318 cm	<b>125"</b>	318 cm	<b>125"</b>
Ground Bearing Pressure	382 kPa	<b>55 psi</b>	247 kPa	<b>36 psi</b>	248 kPa	<b>36 psi</b>
Optional Link Length	259 cm	<b>102"</b>	—		—	
Ground Bearing Pressure	298 kPa	<b>43 psi</b>	—		—	

<sup>1</sup>Based on 19 m<sup>3</sup> (25 yd<sup>3</sup>) dipper.

<sup>2</sup>Based on 24 m<sup>3</sup> (32 yd<sup>3</sup>) dipper.

<sup>3</sup>Based on 32 m<sup>3</sup> (42 yd<sup>3</sup>) dipper.

<sup>4</sup>Based on 56 m<sup>3</sup> (73 yd<sup>3</sup>) dipper.

<sup>5</sup>Based on 45 m<sup>3</sup> (59 yd<sup>3</sup>) dipper.

Information subject to change.

All dimensions are approximate.

**DIPPER SELECTION**

Selecting the correct dipper size plays an integral role in maximizing productivity from a truck shovel operation. Optimal dipper size is a function of truck size, material loose density, and fill factor.

The first step in calculating dipper size is to determine the machine’s optimal payload based on truck size. To calculate this, divide truck payload by three and four (three or four pass even loading is ideal for high productivity). Compare these values to the machine’s maximum payload. The machine’s optimal payload is the largest value that is less than the maximum payload.

For example, consider a mine operating a 7495 shovel (maximum payload = 120 tons) and 797 trucks (payload = 400 tons).  $400 \div 3 = 133.3$  and  $400 \div 4 = 100$ . 133.3 can be eliminated as it is greater than the shovel’s maximum payload (120 tons). 100 tons is the largest value less than the machine’s maximum payload, and therefore, is the machine’s optimal payload.

Once optimal machine payload is determined, material loose density and fill factor are used to calculate the optimum dipper size. To calculate material loose density, divide insitu (undisturbed material density) by  $1 + \text{swell factor}$ .

$$\text{Material loose density} = \frac{\text{Insitu}}{(1 + \text{swell factor})}$$

Once material loose density is calculated, use the equation below to find the optimal dipper size. Fill factor is affected by the dipper geometry, rake angle, and material properties, including fragmentation and critical angle of repose. Fill factors are generally between 90% and 115% for efficiently-sized dippers.

$$\text{Optimal dipper size} = \frac{\text{Optimal machine payload}}{\text{Material loose density}} \times \text{Fill factor}$$

*For example:* For a mine with the following conditions:

- Insitu: 2.276 ton/yd<sup>3</sup>
- Swell factor: 35%
- Fill factor: 95%
- Optimal machine payload: 100 tons

$$\text{Optimal dipper size} = \frac{100 \text{ tons}}{2.276 \div (1 + 0.35)} \times .95 = 62.5 \text{ yd}^3$$

<b>MODEL</b>	<b>7295</b>		<b>7395</b>		<b>7495 HD</b>		<b>7495</b>	
Dipper Range	19.1- 38.2 m <sup>3</sup>	<b>25- 50 yd<sup>3</sup></b>	20.6- 55.8 m <sup>3</sup>	<b>27- 73 yd<sup>3</sup></b>	27.5- 60.4 m <sup>3</sup>	<b>36- 79 yd<sup>3</sup></b>	30.6- 62.7 m <sup>3</sup>	<b>40- 82 yd<sup>3</sup></b>

<b>MODEL</b>	<b>7495 HydraCrowd</b>		<b>7495 HF</b>		<b>7495 HF HydraCrowd</b>	
Dipper Range	30.6-62.7 m <sup>3</sup>	<b>40-82 yd<sup>3</sup></b>	30.6-62.7 m <sup>3</sup>	<b>40-82 yd<sup>3</sup></b>	30.6-62.7 m <sup>3</sup>	<b>40-82 yd<sup>3</sup></b>

Information subject to change.

## TRUCK MATCH

Truck shovel match, or the number of passes necessary to load a truck, has a major impact on an operation's

productivity. To optimize productivity, 3 to 4 even pass loading of trucks is ideal. The chart below shows pass match between Cat electric rope shovels and Cat trucks.

MODEL	Payload	7295	7395	7495 HD	7495	7495 HF
	tonne (ton)	45 (50)	64 (70)	82 (90)	109* (120*)	109* (120*)
785D	136 (150)	3				
789D	181 (200)	4	3			
MT4400D AC	221 (244)		4	3		
793F	227 (250)		4	3		
794 AC	291 (320)			4	3	3
795F AC	313 (345)			4	3	3
797F	363 (400)				4	4

\*Indicates maximum payload.

## RATED SUSPENDED LOAD

Rated Suspended Load is the designed maximum load limit for any Cat Electric Rope Shovel (ERS) model/machine serial number. The maximum load limit is defined as the combined total of Dipper Weight plus Struck Payload Weight.

- **Dipper Weight:** Dipper Weight is the combined total dead weights of dipper body, GET, lip and corner shrouds, dipper door, door latch assembly, wear liner packages for body and door, snubbers, pitch braces, padlocks and pins/pin retainers. (**Note:** Handle weight is NOT included in calculation of Dipper Weight.)
- **Struck Payload Weight:** Struck Payload Weight is the live weight of the material in the dipper. This is a calculated payload weight based on the struck volume of the dipper multiplied by the density of the loose material in the dipper.

Struck volume of a dipper is the contained interior volume of the dipper from the closed door up to the plane of a straight line from the front edge of the dipper back (top) to a point on the dipper lip (floor) where the teeth are attached.

The below values for Rated Suspended Loads (RSL) for Cat Electric Rope Shovels are applicable to shovels commissioned on or after June 1, 2016. Since Cat Electric Rope Shovels have seen numerous upgrades throughout their history which will affect shovel capability, a Rated Suspended Load (RSL) value based on the specific configuration of each machine is more appropriate for machines manufactured or commissioned prior to that date.

ERS MODEL	Rated Suspended Load (RSL)	
7295	81 647 kg	<b>180,000 lb</b>
7395	117 934 kg	<b>260,000 lb</b>
7495 HD	154 221 kg	<b>340,000 lb</b>
7495 with 100 tonnes (110 short tons) Payload	185 973 kg	<b>410,000 lb</b>
7495 HF with 100 tonnes (110 short tons) Payload	185 973 kg	<b>410,000 lb</b>
7495 with 109 tonnes (120 short tons) Payload	195 045 kg	<b>430,000 lb</b>
7495 HF with 109 tonnes (120 short tons) Payload	195 045 kg	<b>430,000 lb</b>



**10/10/20 LOAD MANAGEMENT POLICY —  
ELECTRIC ROPE SHOVELS**

“Machine overload” shall consist of operating the shovel(s) outside of the acceptable allowable load distribution.

The customer shall be responsible for the monitoring and management of all shovel operational activities, including, but not limited to, management of the machine loading such that its loaded distribution is within the acceptable allowable load distribution.

Operating outside of these parameters over any rolling 30 day period can void the customer’s standard warranty; any extended warranty; any availability guarantee and/or result in adjustments to Caterpillar’s obligations under any contract or agreement.

**Loading Distribution**

Loading use over any rolling 30 Day period analyzed:

- No more than 10% of loads should exceed 110% of rated payload.
- No load should exceed 120% of rated payload.
- The average of all loads for the unit not to exceed the rated payload.

**KEY**

- 90% of loads should fall into this range.
- No more than 10% of loads should exceed 110% of the target payload.
- No loads should be above 120% of the target payload.

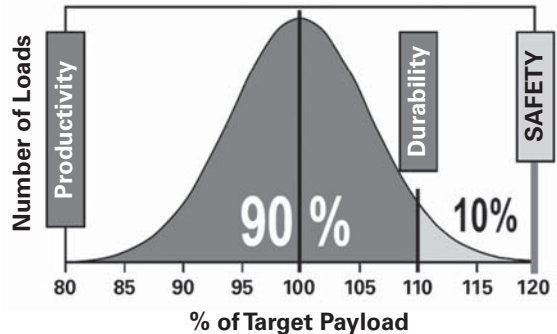

Loading use in excess of this prescribed distribution is considered “machine overload.”

**Notes**

- For this policy to be in effect, the “operational cycle” payload feedback must be available to the operator in order that the customer can control actual payloads.
- Customer must procure, install, and use AccessDirect, MIDAS, and Accuload, and the data must be provided to Caterpillar unmodified and unencumbered.
- Caterpillar must be notified in a timely fashion if the payload monitoring and feedback system is out of service.

# HYDRAULIC MINING SHOVELS

## CONTENTS

### HYDRAULIC MINING SHOVELS

General Introduction . . . . .	16-49
Features . . . . .	16-50
Specifications . . . . .	16-51
Digging Envelopes/Working Range/ Digging Forces . . . . .	16-60
General Dimensions . . . . .	16-71
Ground Pressures . . . . .	16-76
Bucket Selection . . . . .	16-79
Cycle Times . . . . .	16-80
Production Overviews . . . . .	16-82

## GENERAL INTRODUCTION

### Hydraulic Mining Shovels

Hydraulic mining shovels are designed to move large volumes of materials, and the majority are employed in the mining industry for loading large Mining and Off-Highway Trucks. Key design characteristics are high digging forces and quick working cycles for best performance, and a durable design to handle severe working conditions. Hydraulic mining shovels dig and load various commodities, such as gold, copper, iron ore, diamonds and coal, or they remove overburden, in any climatic condition around the world. Typically operated around the clock, Hydraulic Mining Shovels accumulate up to 6500 hours per year.

### Nomenclature

The 6000 Series constitutes the Cat hydraulic mining shovel product line. The name of each individual model gives a direct reference to the size of the machine and consists of a four-digit number, plus additional capital letters in specific cases, depending on the particular drive system and attachment configuration.

The first digit designates the 6000 Series and is followed by another three digits indicating the approximate bucket payload of that model in metric tonnes. Without any extra letters, the specific model is a diesel driven hydraulic mining shovel with a backhoe attachment. If the machine has a front shovel attachment with diesel drive, the letters “FS,” are added to the four-digit number, separated by a space character. An electrically driven hydraulic mining shovel will show an inserted “AC” after the four-digit number. For instance a 6030 FS is a front shovel with a payload of approximately 30 metric tonnes and diesel engines.

The following table gives a summary of all versions currently available.

Diesel Drive		Electric Drive	
Backhoe	Front Shovel	Backhoe	Front Shovel
6015B	N/A	N/A	N/A
6020B	N/A	N/A	N/A
6030	6030 FS	6030 AC	6030 AC FS
6040	6040 FS	6040 AC	6040 AC FS
6050	6050 FS	6050 AC	6050 AC FS
6060	6060 FS	6060 AC	6060 AC FS
N/A	6090 FS	N/A	6090 AC FS

N/A = Not Available

### Technical Specifications

All data given herewith is subject to change. The specs/sheets for individual models may have been updated after publishing of this Performance Handbook edition.

### Contact Details

If there are any questions or comments regarding the information on hydraulic mining shovels given in this chapter please contact:

*Boernke\_Volker@cat.com* or  
*Tegtmeier\_Dirk@cat.com*

### TriPower

On all face shovel (FS) models, Caterpillar uses a unique boom design, called TriPower, that employs rotatable triangular rockers to generate superior mechanical leverage and control. This unique Caterpillar design results in:

- Increased effective lifting force
- Constant boom momentum
- Automatic constant bucket angle position in horizontal and vertical direction
- Automatic roll-back limiter

Furthermore, the TriPower system enables Cat hydraulic front shovels to use smaller-diameter boom cylinders. This benefit results in faster lifting speeds.

### Superior Oil Cooling System

From 6020B up to 6090 FS the independent oil cooling system utilizes dedicated pumps to provide cooling capacity as needed, whether the engine is idling or under load, whereas conventional cooling systems only provide cooling when the engine is under load and the machine is working. Consequently, on above Cat hydraulic mining shovels, the hydraulic oil circulates through the cooling system even when the machine is waiting for the next truck. This system provides a more efficient means of cooling, particularly in demanding applications. The radiator fan speed is thermostatically or electronically controlled for greater efficiency.

### Closed-Loop Swing Circuit

The Cat closed-loop swing circuit results in fast boom lift motions during swing. The kinetic energy of the swing motion is used during deceleration to support driving the main and auxiliary pumps. Compared to conventional open circuit systems, the Cat closed-loop swing circuit is more energy-efficient, generates less heat and delivers faster speeds.

The new 6020B includes an open-loop swing circuit due to its newly designed advanced hydraulics. Utilizing patent-pending dedicated pump flow allocation technology, hydraulic pumps are allocated to individual circuits on demand, allowing all produced oil flow to be translated into cylinder motion, minimizing hydraulic inefficiencies and heat generation. To fully leverage the advantages of this innovative technology, the open-loop swing system was incorporated for its use of a common set of pumps to serve all functions and the flexibility it offers for utilization of hydraulic flow.

### Simple and Efficient Hydraulic System

From 6020B up to 6090 FS the main hydraulic valve block is located on top of the boom. This design reduces the total number of hoses that are needed and ensures they are neatly organized for safe operation, easy inspection and fast service. Because float valves are used to lower the boom instead of engaging pumps, the boom moves faster and other operating functions can occur simultaneously, such as bucket curl and stick in/out. This results in faster cycle times.

### Monitoring and Diagnostic System

Enhancing diagnostic capabilities and providing detailed troubleshooting functions, the Board Control System uses sensors throughout the machine to monitor operating data, record faults, and notify the operator audibly and visually. This promotes the earliest possible detection of faults and allows for timely maintenance planning and assistance for speedy repair.

### Machine Accessibility

Systems throughout Cat hydraulic mining shovels are designed for easy access, enhancing serviceability.

- **Hydraulic Valve Block** — The valve block is located on the boom where it's cleanly laid out and easily accessed by walkways on both sides. This reduces the number of hoses leading from the superstructure.
- **Superstructure** — Exceptional accessibility is provided to systems like the swing motor, swing gearbox and rotary distributor in the well-organized superstructure. The engine is accessible from three sides on most models.

MODEL	6015B		6020B	
Total Flywheel Power: Net	556 kW	<b>746 hp</b>	778 kW	<b>1043 hp</b>
Approximate Operating Weight*	140 000 kg	<b>308,647 lb</b>	230 200 kg	<b>507,500 lb</b>
Standard Bucket Capacity (heaped 1:1)	8.1 m <sup>3</sup>	<b>10.6 yd<sup>3</sup></b>	12.0 m <sup>3</sup>	<b>15.7 yd<sup>3</sup></b>
Standard Engine Model:	<b>C27 ACERT™</b>		<b>C32 ACERT</b>	
Number of Engines	<b>1</b>		<b>1</b>	
Rated Net Power SAE J1349	556 kW	<b>746 hp</b>	778 kW	<b>1043 hp</b>
Rated Engine RPM	<b>1800</b>		<b>1800</b>	
Displacement	27.0 L	<b>1648 in<sup>3</sup></b>	32.0 L	<b>1959 in<sup>3</sup></b>
No. Cylinders	<b>12</b>		<b>12</b>	
Emission Standards	<b>Tier 4 Final<sup>1</sup></b>		<b>Tier 4 Interim equivalent<sup>2</sup></b>	
Maximum Hydraulic Pump Output at Rated RPM:				
Implement	1544 L/min	<b>407 gpm</b>	2350 L/min	<b>621 gpm</b>
Swing	479 L/min	<b>127 gpm</b>	783 L/min	<b>216 gpm</b>
Relief Valve Settings:				
Implement Circuits (attachment)	32 000 kPa	<b>4641 psi</b>	31 000 kPa	<b>4495 psi</b>
Travel Circuits	32 000 kPa	<b>4641 psi</b>	31 000 kPa	<b>4495 psi</b>
Swing Circuits	36 500 kPa	<b>5294 psi</b>	35 000 kPa	<b>5080 psi</b>
Pilot Circuits	9500 kPa	<b>1378 psi</b>	3500 kPa	<b>508 psi</b>
Maximum Swing Speed	<b>4.9 RPM</b>		<b>4.9 RPM</b>	
Maximum Drawbar Pull	983 kN	<b>220,987 lbf</b>	1052 kN	<b>236,420 lbf</b>
Maximum Travel Speed at Rated RPM:				
Low	2.3 km/h	<b>1.3 mph</b>	1.2 km/h	<b>0.75 mph</b>
High	3.3 km/h	<b>2.1 mph</b>	2.7 km/h	<b>1.68 mph</b>
Standard Track Pad Width	700 mm	<b>28"</b>	800 mm	<b>2'7"</b>
Track Gauge	4100 mm	<b>13'5"</b>	4700 mm	<b>15'5"</b>
Overall Track Length	7000 mm	<b>23'0"</b>	7520 mm	<b>24'8"</b>
Fuel Tank Capacity	1700 L	<b>449 U.S. gal</b>	3600 L	<b>951 U.S. gal</b>
Hydraulic Oil System (includes tank)	1572 L	<b>463 U.S. gal</b>	3500 L	<b>925 U.S. gal</b>
Hydraulic Oil Tank	956 L	<b>253 U.S. gal</b>	2800 L	<b>740 U.S. gal</b>
Standard Backhoe Attachment:				
Monoboam	7600 mm	<b>24'11"</b>	8700 mm	<b>28'7"</b>
Stick	3400 mm	<b>11'2"</b>	3900 mm	<b>12'10"</b>
Bucket Range	5.8-10.4 m <sup>3</sup>	<b>7.6-13.6 yd<sup>3</sup></b>	12.0-13.7 m <sup>3</sup>	<b>15.7-17.9 yd<sup>3</sup></b>
Maximum Tearout Force	458 kN	<b>103,000 lbf</b>	650 kN	<b>146,125 lbf</b>
Maximum Breakout Force	586 kN	<b>131,700 lbf</b>	730 kN	<b>164,050 lbf</b>

\*Operating weights include coolant, lubricants, full fuel tank, standard track pads, standard bucket and operator.

<sup>1</sup>There are also products available to meet Tier 2 equivalent OR Tier 1 equivalent emission standards.

<sup>2</sup>There are also products available to meet Tier 2 equivalent emission standards. Please contact your local Cat dealer for product availability.

MODEL	6030		6040	
Total Flywheel Power: Net	1140 kW	<b>1530 hp</b>	1516 kW	<b>2032 hp</b>
Approximate Operating Weight*	296 500 kg	<b>653,660 lb</b>	407 300 kg	<b>897,930 lb</b>
Standard Bucket Capacity (heaped 1:1)	17.0 m <sup>3</sup>	<b>22.2 yd<sup>3</sup></b>	22.0 m <sup>3</sup>	<b>28.8 yd<sup>3</sup></b>
Standard Engine Model:	<b>C27 ACERT</b>		<b>C32 ACERT</b>	
Number of Engines	2		2	
Rated Net Power SAE J1349	570 kW	<b>765 hp</b>	758 kW	<b>1016 hp</b>
Rated Engine RPM	<b>1800</b>		<b>1750</b>	
Displacement	27.0 L	<b>1648 in<sup>3</sup></b>	32.1 L	<b>1959 in<sup>3</sup></b>
No. Cylinders	<b>12</b>		<b>12</b>	
Emission Standards	<b>Tier 4 Interim equivalent<sup>1</sup></b>		<b>Tier 4 Interim equivalent<sup>1</sup></b>	
Maximum Hydraulic Pump Output at Rated RPM:				
Implement	4 x 552 L/min	<b>4 x 146 gpm</b>	4 x 724 L/min	<b>4 x 191 gpm</b>
Swing	2 x 394 L/min	<b>2 x 104 gpm</b>	4 x 321 L/min	<b>4 x 85 gpm</b>
Relief Valve Settings:				
Implement Circuits (attachment)	31 000 kPa	<b>4465 psi</b>	30 000 kPa	<b>4350 psi</b>
Travel Circuits	36 000 kPa	<b>5220 psi</b>	35 000 kPa	<b>5080 psi</b>
Swing Circuits	35 000 kPa	<b>5080 psi</b>	35 000 kPa	<b>5080 psi</b>
Pilot Circuits	3500 kPa	<b>508 psi</b>	3500 kPa	<b>508 psi</b>
Maximum Swing Speed	<b>4.6 RPM</b>		<b>4.7 RPM</b>	
Maximum Drawbar Pull	1637 kN	<b>367,880 lbf</b>	2097 kN	<b>471,260 lbf</b>
Maximum Travel Speed at Rated RPM:				
Low	1.68 mph	<b>0.87 mph</b>	1.5 km/h	<b>0.93 mph</b>
High	2.7 km/h	<b>1.68 mph</b>	2.5 km/h	<b>1.55 mph</b>
Standard Track Pad Width	1000 mm	<b>3'3"</b>	1200 mm	<b>3'11"</b>
Track Gauge	4800 mm	<b>15'9"</b>	5400 mm	<b>17'9"</b>
Overall Track Length	7660 mm	<b>25'2"</b>	8090 mm	<b>26'7"</b>
Fuel Tank Capacity	5130 L	<b>1355 U.S. gal</b>	7800 L	<b>2060 U.S. gal</b>
Hydraulic Oil System (includes tank)	4570 L	<b>1255 U.S. gal</b>	5800 L	<b>1532 U.S. gal</b>
Hydraulic Oil Tank	3400 L	<b>898 U.S. gal</b>	3400 L	<b>898 U.S. gal</b>
Standard Backhoe Attachment:				
Monoboom	8500 mm	<b>27'11"</b>	9500 mm	<b>31'2"</b>
Stick	4000 mm	<b>13'1"</b>	4600 mm	<b>15'1"</b>
Bucket Range	12.0-17.0 m <sup>3</sup>	<b>15.7-22.2 yd<sup>3</sup></b>	15.0-24.0 m <sup>3</sup>	<b>19.6-31.4 yd<sup>3</sup></b>
Maximum Tearout Force	920 kN	<b>206,750 lbf</b>	1020 kN	<b>229,220 lbf</b>
Maximum Breakout Force	890 kN	<b>200,010 lbf</b>	1120 kN	<b>251,700 lbf</b>

\*Operating weights include coolant, lubricants, full fuel tank, standard track pads, standard bucket and operator.

<sup>1</sup>There are also products available to meet Tier 2 equivalent emission standards. Please contact your local Cat dealer for product availability.

MODEL	6050		6060	
Total Flywheel Power: Net	1880 kW	<b>2520 hp</b>	2240 kW	<b>3000 hp</b>
Approximate Operating Weight*	537 000 kg	<b>1,183,870 lb</b>	570 300 kg	<b>1,257,280 lb</b>
Standard Bucket Capacity (heaped 1:1)	28.0 m <sup>3</sup>	<b>36.6 yd<sup>3</sup></b>	34.0 m <sup>3</sup>	<b>44.5 yd<sup>3</sup></b>
Standard Engine Model:	<b>QSK38</b>		<b>3512C</b>	
Number of Engines	2		2	
Rated Net Power SAE J1349	940 kW	<b>1260 hp</b>	1120 kW	<b>1500 hp</b>
Rated Engine RPM	<b>1800</b>		<b>1800</b>	
Displacement	37.8 L	<b>2300 in<sup>3</sup></b>	58.6 L	<b>3574 in<sup>3</sup></b>
No. Cylinders	<b>12</b>		<b>12</b>	
Emission Standards	<b>Tier 4 Interim equivalent<sup>1</sup></b>		<b>Tier 4 Interim equivalent<sup>1</sup></b>	
Optional Engine Model:	<b>K1500E</b>		—	
Number of Engines	2		—	
Rated Net Power SAE J1349	900 kW	<b>1260 hp</b>	—	
Rated Engine RPM	<b>1800</b>		—	
Displacement	37.8 L	<b>2300 in<sup>3</sup></b>	—	
No. Cylinders	<b>12</b>		—	
Emission Standards	<b>Tier 1 equivalent</b>		—	
Maximum Hydraulic Pump Output at Rated RPM:				
Implement	4 × 912 L/min	<b>4 × 241 gpm</b>	4 × 1300 L/min	<b>4 × 343 gpm</b>
Swing	4 × 351 L/min	<b>4 × 93 gpm</b>	4 × 352 L/min	<b>4 × 93 gpm</b>
Relief Valve Settings:				
Implement Circuits (attachment)	30 000 kPa	<b>4350 psi</b>	32 000 kPa	<b>4640 psi</b>
Travel Circuits	34 000 kPa	<b>4930 psi</b>	37 000 kPa	<b>5365 psi</b>
Swing Circuits	35 000 kPa	<b>5080 psi</b>	37 000 kPa	<b>5365 psi</b>
Pilot Circuits	4000 kPa	<b>580 psi</b>	3500 kPa	<b>508 psi</b>
Maximum Swing Speed	<b>3.8 RPM</b>		<b>3.8 RPM</b>	
Maximum Drawbar Pull	2576 kN	<b>578,900 lbf</b>	2956 kN	<b>664,300 lbf</b>
Maximum Travel Speed at Rated RPM:				
Low	1.6 km/h	<b>0.99 mph</b>	1.4 km/h	<b>0.87 mph</b>
High	2.3 km/h	<b>1.44 mph</b>	2.0 km/h	<b>1.24 mph</b>
Standard Track Pad Width	1400 mm	<b>4'7"</b>	1400 mm	<b>4'7"</b>
Track Gauge	5600 mm	<b>18'4"</b>	5600 mm	<b>18'4"</b>
Overall Track Length	8540 mm	<b>28'0"</b>	9230 mm	<b>30'3"</b>
Fuel Tank Capacity	10 700 L	<b>2820 U.S. gal</b>	13 000 L	<b>3435 U.S. gal</b>
Hydraulic Oil System (includes tank)	7800 L	<b>2060 U.S. gal</b>	9400 L	<b>2483 U.S. gal</b>
Hydraulic Oil Tank	5500 L	<b>1450 U.S. gal</b>	7100 L	<b>1876 U.S. gal</b>
Standard Backhoe Attachment:				
Monoboom	10 500 mm	<b>34'5"</b>	10 500 mm	<b>34'5"</b>
Stick	5500 mm	<b>18'1"</b>	5000 mm	<b>16'5"</b>
Bucket Range	25.0-28.0 m <sup>3</sup>	<b>32.7-36.6 yd<sup>3</sup></b>	25.0-34.0 m <sup>3</sup>	<b>32.7-44.5 yd<sup>3</sup></b>
Maximum Tearout Force	1100 kN	<b>247,200 lbf</b>	1220 kN	<b>274,170 lbf</b>
Maximum Breakout Force	1210 kN	<b>271,920 lbf</b>	1240 kN	<b>278,670 lbf</b>

\*Operating weights include coolant, lubricants, full fuel tank, standard track pads, standard bucket and operator.

<sup>1</sup>There are also products available to meet Tier 2 equivalent emission standards. Please contact your local Cat dealer for product availability.

<b>MODEL</b>	<b>6030 AC</b>		<b>6040 AC</b>	
Total Output	<b>1000 kW</b>		<b>1400 kW</b>	
Operating Weight	296 500 kg	<b>653,660 lb</b>	407 000 kg	<b>897,270 lb</b>
Electric Motor Type:	<b>Squirrel cage induction motor</b>		<b>Squirrel cage induction motor</b>	
Number of Motors	<b>1</b>		<b>1</b>	
Standard Voltage*	<b>6.3 kV ± 10%</b>		<b>6.6 kV ± 10%</b>	
Rated Current I <sub>N</sub> (at standard voltage)	<b>109 A</b>		<b>156 A</b>	
Standard Frequency*	<b>50 Hz</b>		<b>50 Hz</b>	
Standard Revolutions*	<b>1500 RPM</b>		<b>1500 RPM</b>	
Starting Current (direct start)	<b>450% of I<sub>N</sub></b>		<b>350% of I<sub>N</sub></b>	
Starting Current (soft start, optional)	<b>253% of I<sub>N</sub></b>		<b>197% of I<sub>N</sub></b>	
Maximum Hydraulic Pump Output at Rated RPM:				
Implement	4 × 543 L/min	<b>4 × 143 gpm</b>	4 × 746 L/min	<b>4 × 197 gpm</b>
Swing	2 × 426 L/min	<b>2 × 113 gpm</b>	3 × 491 L/min	<b>3 × 130 gpm</b>
Maximum Swing Speed	<b>5.0 RPM</b>		<b>5.1 RPM</b>	
Maximum Travel Speed at Standard RPM:				
Low	1.4 km/h	<b>0.87 mph</b>	1.5 km/h	<b>0.93 mph</b>
High	2.7 km/h	<b>1.68 mph</b>	2.5 km/h	<b>1.55 mph</b>

\*Other voltages and frequencies like 7.2 kV/60 Hz are available on request.

**NOTE:** Other specifications of the diesel driven shovels remain unchanged.

MODEL	6050 AC		6060 AC	
Total Output	<b>1600 kW</b>		<b>1800 kW</b>	
Operating Weight	524 500 kg	<b>1,156,310 lb</b>	547 700 kg	<b>1,207,460 lb</b>
Electric Motor Type:	<b>Squirrel cage induction motor</b>		<b>Squirrel cage induction motor</b>	
Number of Motors	<b>1</b>		<b>1</b>	
Standard Voltage*	<b>6.6 kV ± 10%</b>		<b>6.6 kV ± 10%</b>	
Rated Current I <sub>N</sub> (at standard voltage)	<b>174 A</b>		<b>194 A</b>	
Standard Frequency*	<b>50 Hz</b>		<b>50 Hz</b>	
Standard Revolutions*	<b>1500 RPM</b>		<b>1500 RPM</b>	
Starting Current (direct start)	<b>350% of I<sub>N</sub></b>		<b>350% of I<sub>N</sub></b>	
Starting Current (soft start, optional)	<b>197% of I<sub>N</sub></b>		<b>197% of I<sub>N</sub></b>	
Maximum Hydraulic Pump Output at Rated RPM:				
Implement	4 × 933 L/min	<b>4 × 246 gpm</b>	4 × 933 L/min	<b>4 × 246 gpm</b>
Swing	3 × 491 L/min	<b>3 × 131 gpm</b>	3 × 491 L/min	<b>3 × 131 gpm</b>
Maximum Swing Speed	<b>4.0 RPM</b>		<b>4.0 RPM</b>	
Maximum Travel Speed at Standard RPM:				
Low	1.6 km/h	<b>0.99 mph</b>	1.4 km/h	<b>0.87 mph</b>
High	2.3 km/h	<b>1.44 mph</b>	2.7 km/h	<b>1.68 mph</b>

\*Other voltages and frequencies like 7.2 kV/60 Hz are available on request.

**NOTE:** Other specifications of the diesel driven shovels remain unchanged.



MODEL	6030 FS		6040 FS		6050 FS	
Total Flywheel Power: Net	1140 kW	<b>1530 hp</b>	1516 kW	<b>2032 hp</b>	1880 kW	<b>2520 hp</b>
Approximate Operating Weight*	294 300 kg	<b>648,810 lb</b>	404 600 kg	<b>891,980 lb</b>	527 600 kg	<b>1,163,150 lb</b>
Standard Bucket Capacity (heaped 2:1)	16.5 m <sup>3</sup>	<b>21.6 yd<sup>3</sup></b>	22.0 m <sup>3</sup>	<b>28.8 yd<sup>3</sup></b>	26.0 m <sup>3</sup>	<b>34.0 yd<sup>3</sup></b>
Standard Engine Model:	<b>C27 ACERT</b>		<b>C32 ACERT</b>		<b>QSK38</b>	
Number of Engines	2		2		2	
Rated Net Power SAE J1349	570 kW	<b>765 hp</b>	758 kW	<b>1016 hp</b>	900 kW	<b>1260 hp</b>
Rated Engine RPM	<b>1800</b>		<b>1750</b>		<b>1800</b>	
Displacement	27.0 L	<b>1648 in<sup>3</sup></b>	32.1 L	<b>1959 in<sup>3</sup></b>	37.8 L	<b>2300 in<sup>3</sup></b>
No. Cylinders	<b>12</b>		<b>12</b>		<b>12</b>	
Emission Standards	<b>Tier 4 Interim equivalent<sup>1</sup></b>		<b>Tier 4 Interim equivalent<sup>1</sup></b>		<b>Tier 4 Interim equivalent<sup>1</sup></b>	
Optional Engine Model:	—		—		<b>K1500E</b>	
Number of Engines	—		—		2	
Rated Net Power SAE J1349	—		—		900 kW	<b>1260 hp</b>
Rated Engine RPM	—		—		<b>1800</b>	
Displacement	—		—		37.8 L	<b>2300 in<sup>3</sup></b>
No. Cylinders	—		—		<b>12</b>	
Emission Standards	—		—		<b>Tier 1 equivalent</b>	
Maximum Hydraulic Pump Output at Rated RPM:						
Implement	4 x	<b>4 x</b>	4 x	<b>4 x</b>	4 x	<b>4 x</b>
	552 L/min	<b>146 gpm</b>	724 L/min	<b>191 gpm</b>	912 L/min	<b>241 gpm</b>
Swing	2 x	<b>2 x</b>	4 x	<b>4 x</b>	4 x	<b>4 x</b>
	288 L/min	<b>104 gpm</b>	321 L/min	<b>85 gpm</b>	351 L/min	<b>93 gpm</b>
Relief Valve Settings:						
Implement Circuits (attachment)	31 000 kPa	<b>4465 psi</b>	30 000 kPa	<b>4350 psi</b>	30 000 kPa	<b>4350 psi</b>
Travel Circuits	36 000 kPa	<b>5220 psi</b>	35 000 kPa	<b>5080 psi</b>	34 000 kPa	<b>4930 psi</b>
Swing Circuits	35 000 kPa	<b>5080 psi</b>	35 000 kPa	<b>5080 psi</b>	35 000 kPa	<b>5080 psi</b>
Pilot Circuits	3500 kPa	<b>508 psi</b>	3500 kPa	<b>508 psi</b>	4000 kPa	<b>580 psi</b>
Maximum Swing Speed	<b>4.6 RPM</b>		<b>4.7 RPM</b>		<b>3.8 RPM</b>	
Maximum Drawbar Pull	1637 kN	<b>367,880 lbf</b>	2097 kN	<b>471,260 lbf</b>	2576 kN	<b>578,900 lbf</b>
Maximum Travel Speed at Rated RPM:						
Low	1.4 km/h	<b>0.87 mph</b>	1.5 km/h	<b>0.93 mph</b>	1,6 km/h	<b>0.99 mph</b>
High	2.7 km/h	<b>1.68 mph</b>	2.5 km/h	<b>1.55 mph</b>	2.3 km/h	<b>1.44 mph</b>
Standard Track Pad Width	1000 mm	<b>3'3"</b>	1200 mm	<b>3'11"</b>	1400 mm	<b>4'7"</b>
Track Gauge	4800 mm	<b>15'9"</b>	5400 mm	<b>17'9"</b>	5600 mm	<b>18'4"</b>
Overall Track Length	7660 mm	<b>25'2"</b>	8090 mm	<b>26'7"</b>	8540 mm	<b>28'0"</b>
Fuel Tank Capacity	5130 L	<b>1355 U.S. gal</b>	7800 L	<b>2060 U.S. gal</b>	10 700 L	<b>2820 U.S. gal</b>
Hydraulic Oil System (includes tank)	3500 L	<b>925 U.S. gal</b>	5800 L	<b>1532 U.S. gal</b>	7800 L	<b>2060 U.S. gal</b>
Hydraulic Oil Tank	2500 L	<b>660 U.S. gal</b>	3400 L	<b>898 U.S. gal</b>	5500 L	<b>1450 U.S. gal</b>
TriPower Face Shovel Attachment:						
Boom	6200 mm	<b>20'4"</b>	7300 mm	<b>23'11"</b>	8000 mm	<b>26'2"</b>
Stick	4400 mm	<b>14'5"</b>	4600 mm	<b>15'1"</b>	5100 mm	<b>16'9"</b>
Bucket Range	10.0-	<b>13.1-</b>	15.0-	<b>19.6-</b>	18.0-	<b>23.5-</b>
	16.5 m <sup>3</sup>	<b>21.6 yd<sup>3</sup></b>	22.0 m <sup>3</sup>	<b>28.8 yd<sup>3</sup></b>	28.0 m <sup>3</sup>	<b>36.6 yd<sup>3</sup></b>
Maximum Crowd Force	1320 kN	<b>296,640 lbf</b>	1730 kN	<b>388,780 lbf</b>	1930 kN	<b>433,730 lbf</b>
Maximum Breakout Force	960 kN	<b>215,740 lbf</b>	1200 kN	<b>269,680 lbf</b>	1530 kN	<b>343,840 lbf</b>

\*Operating weights include coolant, lubricants, full fuel tank, standard track pads, standard bucket and operator.

<sup>1</sup> There are also products available to meet Tier 2 equivalent emission standards. Please contact your local Cat dealer for product availability.

MODEL	6060 FS		6090 FS	
Total Flywheel Power: Net	2240 kW	<b>3000 hp</b>	3360 kW	<b>4500 hp</b>
Approximate Operating Weight*	568 900 kg	<b>1,254,200 lb</b>	980 000 kg	<b>2,160,510 lb</b>
Standard Bucket Capacity (heaped 2:1)	34.0 m <sup>3</sup>	<b>44.5 yd<sup>3</sup></b>	52.0 m <sup>3</sup>	<b>68.0 yd<sup>3</sup></b>
Standard Engine Model:	<b>3512C</b>		<b>QSK60</b>	
Number of Engines	2		2	
Rated Net Power SAE J1349	1120 kW	<b>1500 hp</b>	1680 kW	<b>2250 hp</b>
Rated Engine RPM	<b>1800</b>		<b>1800</b>	
Displacement	58.6 L	<b>3574 in<sup>3</sup></b>	60.2 L	<b>3674 in<sup>3</sup></b>
No. Cylinders	<b>12</b>		<b>16</b>	
Emission Standards	<b>Tier 4 Interim equivalent<sup>1</sup></b>		<b>Tier 4 Interim equivalent<sup>1</sup></b>	
Maximum Hydraulic Pump Output at Rated RPM:				
Implement	4 × 1300 L/min	<b>4 × 343 gpm</b>	8 × 936 L/min	<b>8 × 247 gpm</b>
Swing	4 × 352 L/min	<b>4 × 93 gpm</b>	6 × 488 L/min	<b>6 × 129 gpm</b>
Relief Valve Settings:				
Implement Circuits (attachment)	32 000 kPa	<b>4640 psi</b>	30 000 kPa	<b>4350 psi</b>
Travel Circuits	37 000 kPa	<b>5365 psi</b>	36 000 kPa	<b>5220 psi</b>
Swing Circuits	37 000 kPa	<b>5365 psi</b>	35 000 kPa	<b>5080 psi</b>
Pilot Circuits	3500 kPa	<b>508 psi</b>	3500 kPa	<b>508 psi</b>
Maximum Swing Speed	<b>3.8 RPM</b>		<b>3.9 RPM</b>	
Maximum Drawbar Pull	2956 kN	<b>664,300 lbf</b>	4338 kN	<b>974,880 lbf</b>
Maximum Travel Speed at Rated RPM:				
Low	1.4 km/h	<b>0.87 mph</b>	1.4 km/h	<b>0.9 mph</b>
High	2.0 km/h	<b>1.24 mph</b>	1.9 km/h	<b>1.2 mph</b>
Standard Track Pad Width	1400 mm	<b>4'7"</b>	2000 mm	<b>6'7"</b>
Track Gauge	5600 mm	<b>18'4"</b>	6600 mm	<b>21'8"</b>
Overall Track Length	9230 mm	<b>30'3"</b>	10 980 mm	<b>36'0"</b>
Fuel Tank Capacity	13 000 L	<b>3435 U.S. gal</b>	16 400 L	<b>4330 U.S. gal</b>
Hydraulic Oil System (includes tank)	9400 L	<b>2483 U.S. gal</b>	13 000 L	<b>3450 U.S. gal</b>
Hydraulic Oil Tank	7100 L	<b>1876 U.S. gal</b>	10 000 L	<b>2640 U.S. gal</b>
TriPower Face Shovel Attachment:				
Boom	8000 mm	<b>26'2"</b>	9500 mm	<b>31'2"</b>
Stick	5100 mm	<b>16'9"</b>	5800 mm	<b>19'0"</b>
Bucket Range	21.0-34.0 m <sup>3</sup>	<b>27.5-44.5 yd<sup>3</sup></b>	37.0-52.0 m <sup>3</sup>	<b>48.8-68.0 yd<sup>3</sup></b>
Maximum Crowd Force	2250 kN	<b>505,640 lbf</b>	3090 kN	<b>694,420 lbf</b>
Maximum Breakout Force	1740 kN	<b>391,030 lbf</b>	2420 kN	<b>543,850 lbf</b>

\*Operating weights include coolant, lubricants, full fuel tank, standard track pads, standard bucket and operator.

<sup>1</sup>There are also products available to meet Tier 2 equivalent emission standards. Please contact your local Cat dealer for product availability.

<b>MODEL</b>	<b>6030 AC FS</b>		<b>6040 AC FS</b>	
Total Output	<b>1000 kW</b>		<b>1400 kW</b>	
Operating Weight	294 300 kg	<b>648,810 lb</b>	404 300 kg	<b>891,320 lb</b>
Electric Motor Type:	<b>Squirrel cage induction motor</b>		<b>Squirrel cage induction motor</b>	
Number of Motors	<b>1</b>		<b>1</b>	
Standard Voltage*	<b>6.3 kV ± 10%</b>		<b>6.6 kV ± 10%</b>	
Rated Current I <sub>N</sub> (at standard voltage)	<b>109 A</b>		<b>156 A</b>	
Standard Frequency*	<b>50 Hz</b>		<b>50 Hz</b>	
Standard Revolutions*	<b>1500 RPM</b>		<b>1500 RPM</b>	
Starting Current (direct start)	<b>450% of I<sub>N</sub></b>		<b>350% of I<sub>N</sub></b>	
Starting Current (soft start, optional)	<b>253% of I<sub>N</sub></b>		<b>197% of I<sub>N</sub></b>	
Maximum Hydraulic Pump Output at Rated RPM:				
Implement	4 × 543 L/min	<b>4 × 143 gpm</b>	4 × 746 L/min	<b>4 × 197 gpm</b>
Swing	2 × 426 L/min	<b>2 × 113 gpm</b>	3 × 491 L/min	<b>3 × 130 gpm</b>
Maximum Swing Speed	<b>5.0 RPM</b>		<b>5.1 RPM</b>	
Maximum Travel Speed at Standard RPM:				
Low	1.4 km/h	<b>0.87 mph</b>	1.5 km/h	<b>0.93 mph</b>
High	2.7 km/h	<b>1.68 mph</b>	2.5 km/h	<b>1.55 mph</b>

\*Other voltages and frequencies like 7.2 kV/60 Hz are available on request.

**NOTE:** Other specifications of the diesel driven shovels remain unchanged.

MODEL	6050 AC FS		6060 AC FS		6090 AC FS	
Total Output	1600 kW		1800 kW		3200 kW	
Operating Weight	515 100 kg	1,135,590 lb	546 300 kg	1,204,370 lb	955 000 kg	2,105,410 lb
Electric Motor Type:	Squirrel cage induction motor		Squirrel cage induction motor		Squirrel cage induction motor	
Number of Motors	1		1		2	
Standard Voltage*	6.6 kV ± 10%		6.6 kV ± 10%		6.6 kV ± 10%	
Rated Current I <sub>N</sub> (at standard voltage)	174 A		194 A		332 A	
Standard Frequency*	50 Hz		50 Hz		50 Hz	
Standard Revolutions*	1500 RPM		1500 RPM		1500 RPM	
Starting Current (direct start)	350% of I <sub>N</sub>		350% of I <sub>N</sub>		780 A	
Starting Current (soft start, optional)	197% of I <sub>N</sub>		197% of I <sub>N</sub>		N/A	
Maximum Hydraulic Pump Output at Rated RPM:						
Implement	4 x	4 x	4 x	4 x	8 x	8 x
	933 L/min	246 gpm	933 L/min	246 gpm	943 L/min	249 gpm
Swing	3 x	3 x	3 x	3 x	6 x	6 x
	491 L/min	131 gpm	491 L/min	131 gpm	496 L/min	131 gpm
Maximum Swing Speed	4.0 RPM		4.0 RPM		4.1 RPM	
Maximum Travel Speed at Standard RPM:						
Low	1.6 km/h	0.99 mph	1.4 km/h	0.87 mph	1.4 km/h	0.9 mph
High	2.3 km/h	1.44 mph	2.7 km/h	1.68 mph	1.9 km/h	1.2 mph

\*Other voltages and frequencies like 7.2 kV/60 Hz are available on request.

NOTE: Other specifications of the diesel driven shovels remain unchanged.

N/A = Not Available

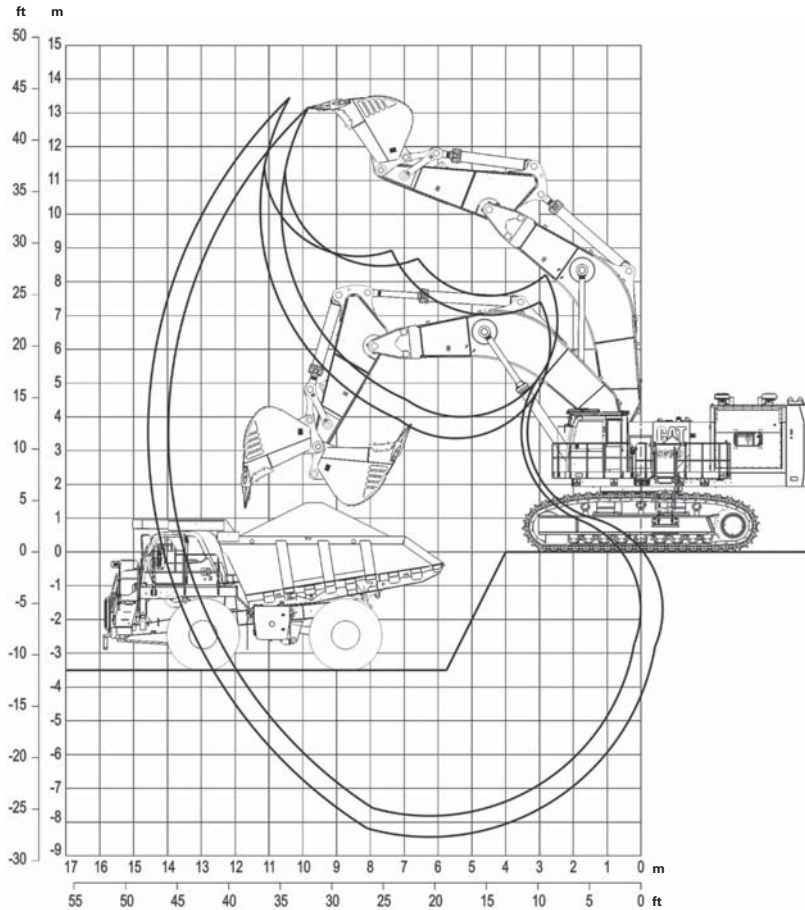

**MODEL**

**6015B**

<b>Stick</b>	3.4 m	11'2"	4.1 m	13'5"
<b>Working Range</b>				
Maximum Digging Depth	7.9 m	25'7"	8.4 m	27'7"
Maximum Digging Reach	13.9 m	45'11"	14.6 m	47'11"
Maximum Digging Height	13.2 m	43'4"	13.5 m	44'3"
<b>Digging Forces</b>				
Maximum Tearout Force (arm cylinder)	458 kN	103,000 lbf	407 kN	91,500 lbf
Maximum Breakout Force (bucket cylinder)	586 kN	131,700 lbf	585 kN	131,500 lbf

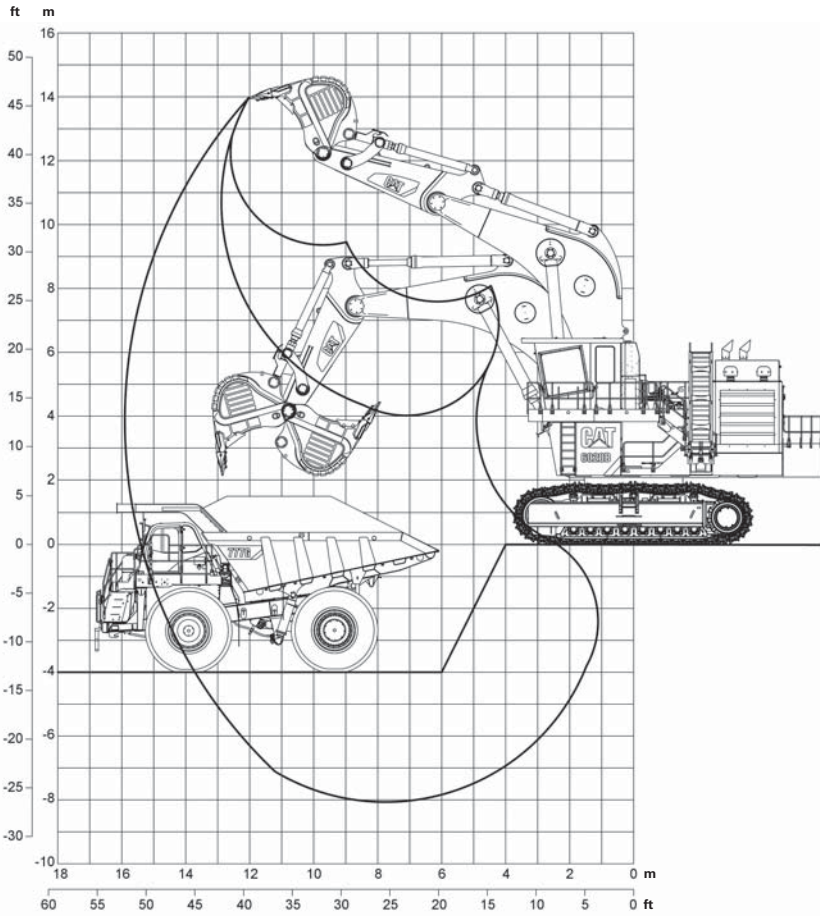

**MODEL**

**6020B**

**Working Range**

Maximum Digging Depth	8.1 m	26'7"
Maximum Digging Reach	15.9 m	52'2"
Maximum Digging Height	13.9 m	45'7"

**Digging Forces**

Maximum Tearout Force (arm cylinder)	650 kN	146,125 lbf
Maximum Breakout Force (bucket cylinder)	730 kN	164,050 lbf

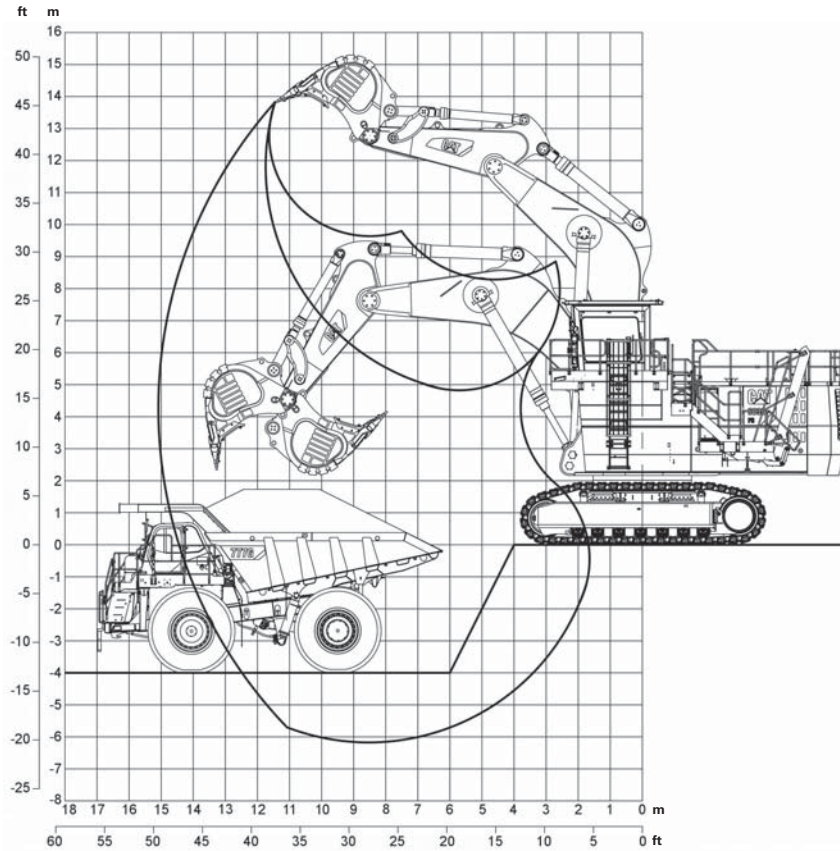

**MODEL**

**6030**

**Working Range**

Maximum Digging Depth	6.2 m	20'4"
Maximum Digging Reach	15.1 m	49'6"
Maximum Digging Height	13.8 m	45'3"

**Digging Forces**

Maximum Tearout Force (arm cylinder)	920 kN	206,750 lbf
Maximum Breakout Force (bucket cylinder)	890 kN	200,010 lbf

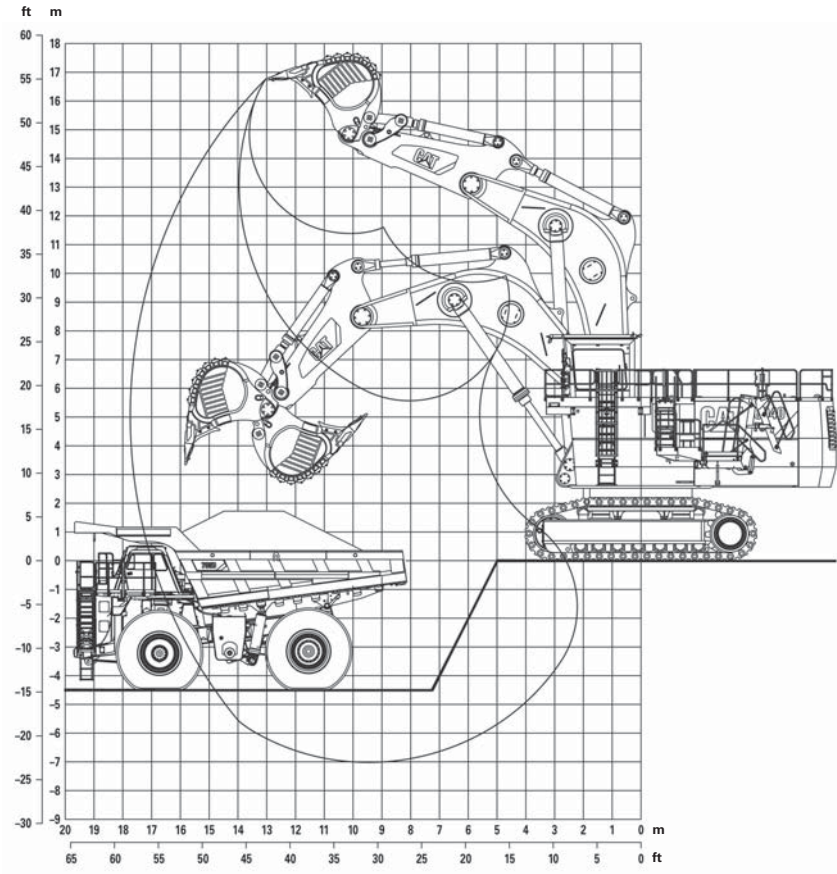

**MODEL**

**6040**

**Working Range**

Maximum Digging Depth	7.0 m	23'0"
Maximum Digging Reach	17.7 m	58'1"
Maximum Digging Height	16.8 m	55'1"

**Digging Forces**

Maximum Tearout Force (arm cylinder)	1020 kN	229,220 lbf
Maximum Breakout Force (bucket cylinder)	1120 kN	251,700 lbf



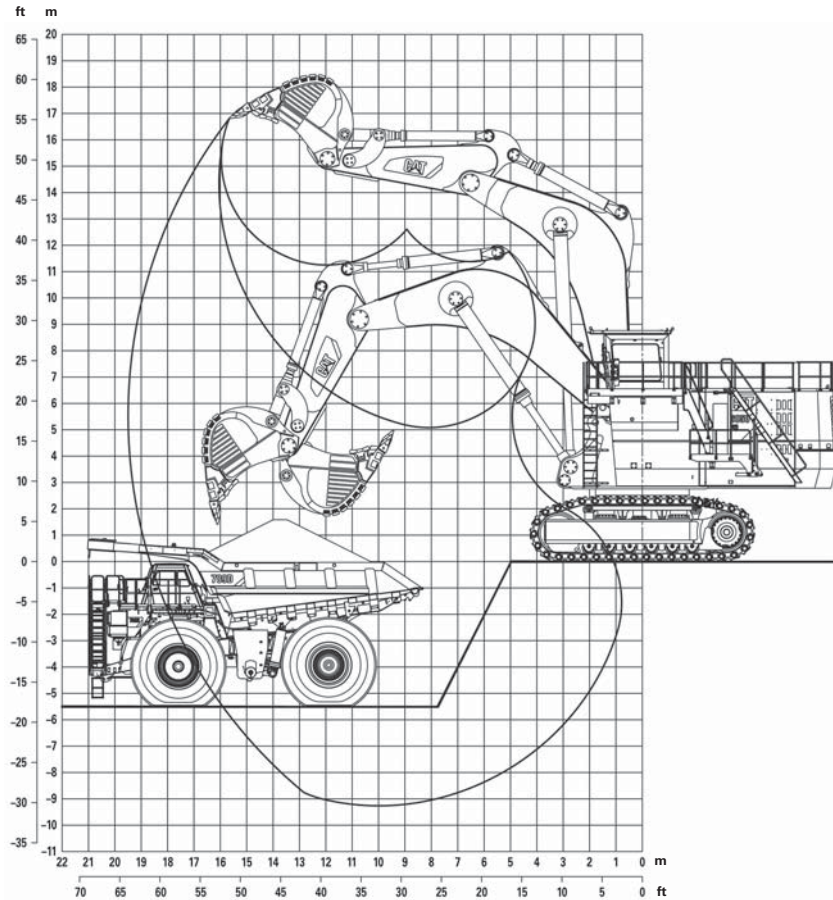

**MODEL**

**6050**

**Working Range**

Maximum Digging Depth	9.2 m	30'2"
Maximum Digging Reach	19.5 m	64'0"
Maximum Digging Height	16.8 m	55'1"

**Digging Forces**

Maximum Tearout Force (arm cylinder)	1100 kN	247,220 lbf
Maximum Breakout Force (bucket cylinder)	1210 kN	271,920 lbf

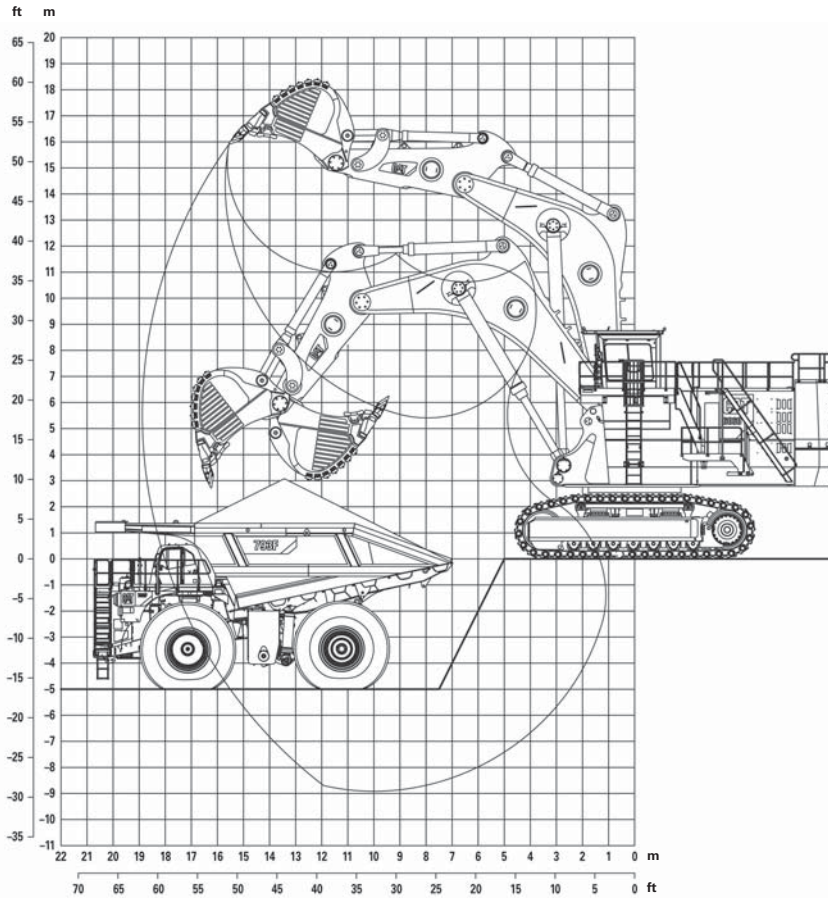

**MODEL**

**6060**

**Working Range**

Maximum Digging Depth	8.9 m	29'2"
Maximum Digging Reach	18.9 m	62'0"
Maximum Digging Height	15.9 m	52'2"

**Digging Forces**

Maximum Tearout Force (arm cylinder)	1220 kN	274,170 lbf
Maximum Breakout Force (bucket cylinder)	1240 kN	278,670 lbf

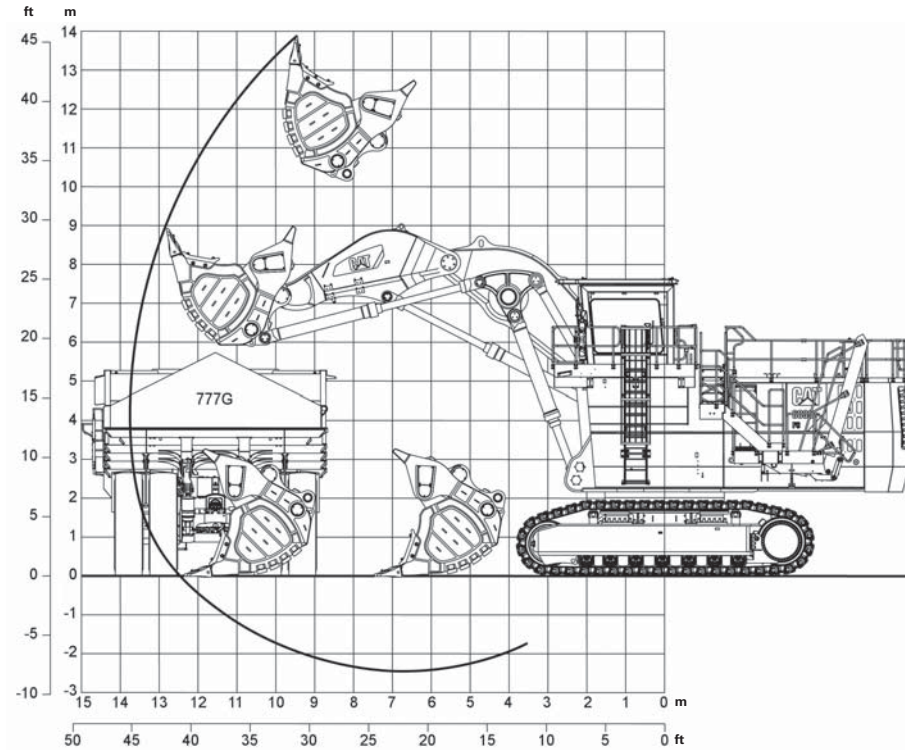

**MODEL**

**6030 FS**

**Working Range**

Maximum Digging Height	13.9 m	45'7"
Maximum Digging Reach	13.7 m	44'11"
Maximum Digging Depth	2.5 m	8'2"
Maximum Dumping Height	10.7 m	35'1"
Crowd Distance on Level	4.9 m	16'1"

**Digging Forces**

Maximum Crowd Force (arm cylinder)	1320 kN	296,640 lbf
Maximum Crowd Force at Ground Level (arm cylinder)	1210 kN	271,920 lbf
Maximum Breakout Force (bucket cylinder)	960 kN	215,740 lbf

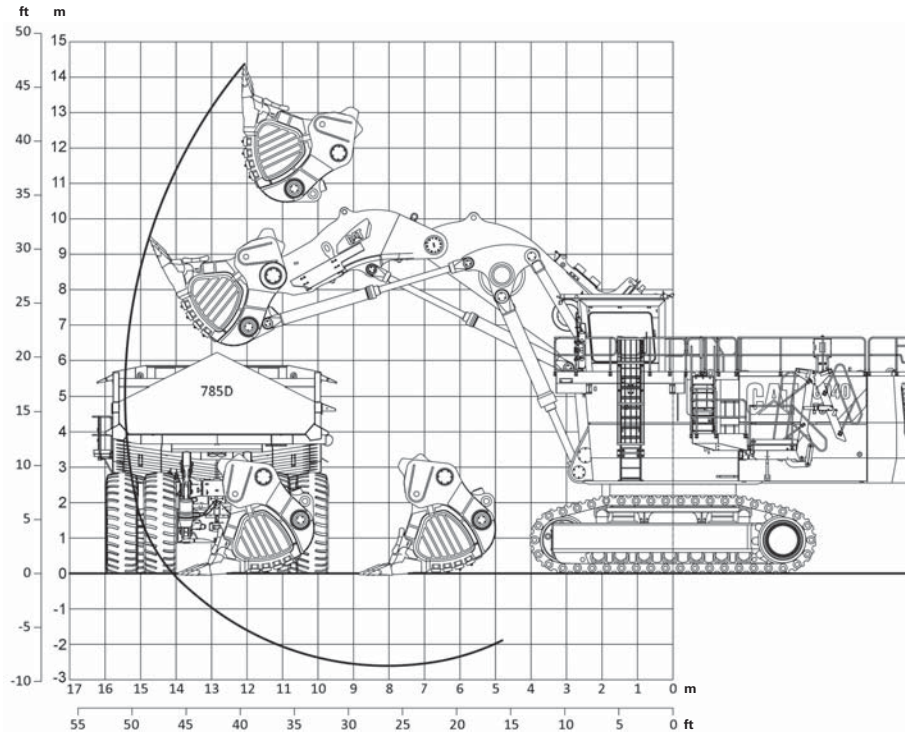

**MODEL**

**6040 FS**

**Working Range**

Maximum Digging Height	14.4 m	47'3"
Maximum Digging Reach	15.4 m	50'6"
Maximum Digging Depth	2.6 m	8'6"
Maximum Dumping Height	10.9 m	35'9"
Crowd Distance on Level	5.1 m	16'9"

**Digging Forces**

Maximum Crowd Force (arm cylinder)	1730 kN	388,780 lbf
Maximum Crowd Force at Ground Level (arm cylinder)	1200 kN	269,680 lbf
Maximum Breakout Force (bucket cylinder)	1200 kN	269,680 lbf

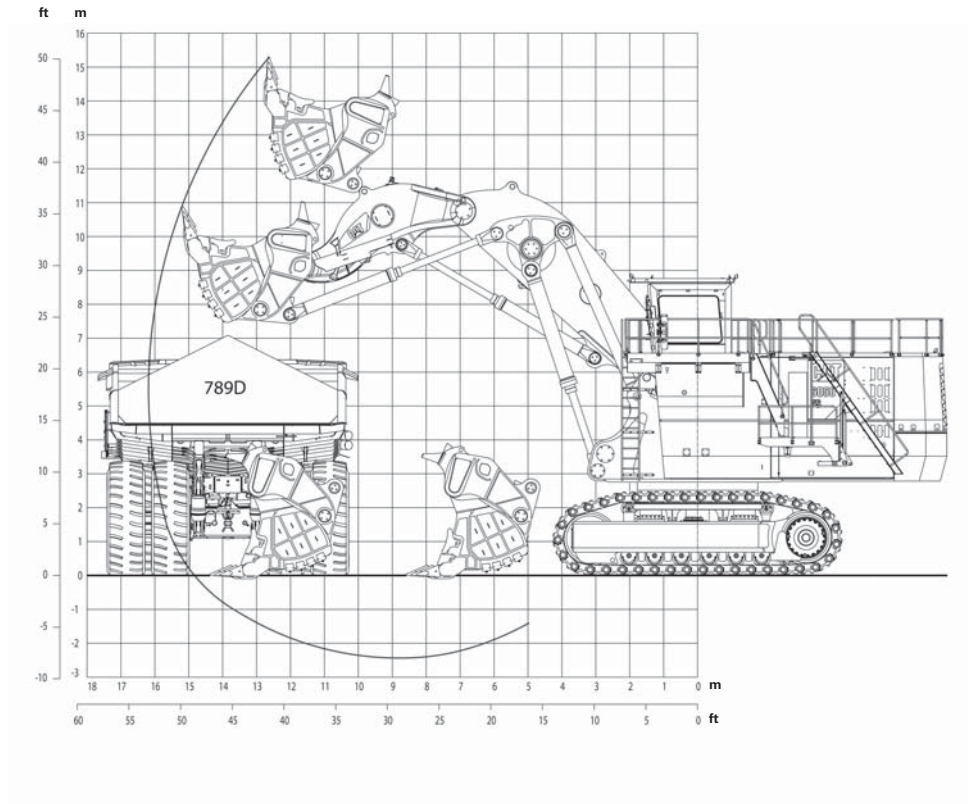

**MODEL**

**6050 FS**

**Working Range**

Maximum Digging Height	15.3 m	50'2"
Maximum Digging Reach	16.2 m	53'2"
Maximum Digging Depth	2.4 m	7'10"
Maximum Dumping Height	11.8 m	38'9"
Crowd Distance on Level	5.5 m	19'0"

**Digging Forces**

Maximum Crowd Force (arm cylinder)	1930 kN	433,730 lbf
Maximum Crowd Force at Ground Level (arm cylinder)	1650 kN	370,800 lbf
Maximum Breakout Force (bucket cylinder)	1530 kN	343,840 lbf

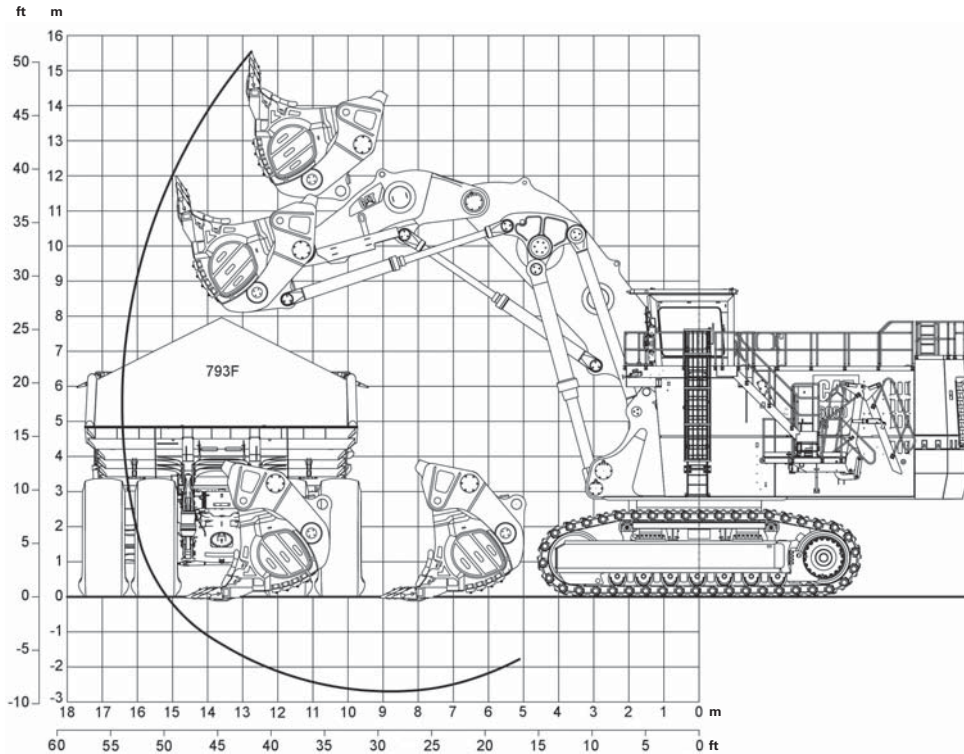

**MODEL**

**6060 FS**

**Working Range**

Maximum Digging Height	15.5 m	50'10"
Maximum Digging Reach	16.4 m	53'10"
Maximum Digging Depth	2.7 m	8'10"
Maximum Dumping Height	11.6 m	38'1"
Crowd Distance on Level	5.5 m	18'1"

**Digging Forces**

Maximum Crowd Force (arm cylinder)	2250 kN	505,640 lbf
Maximum Crowd Force at Ground Level (arm cylinder)	2100 kN	471,930 lbf
Maximum Breakout Force (bucket cylinder)	1740 kN	391,030 lbf

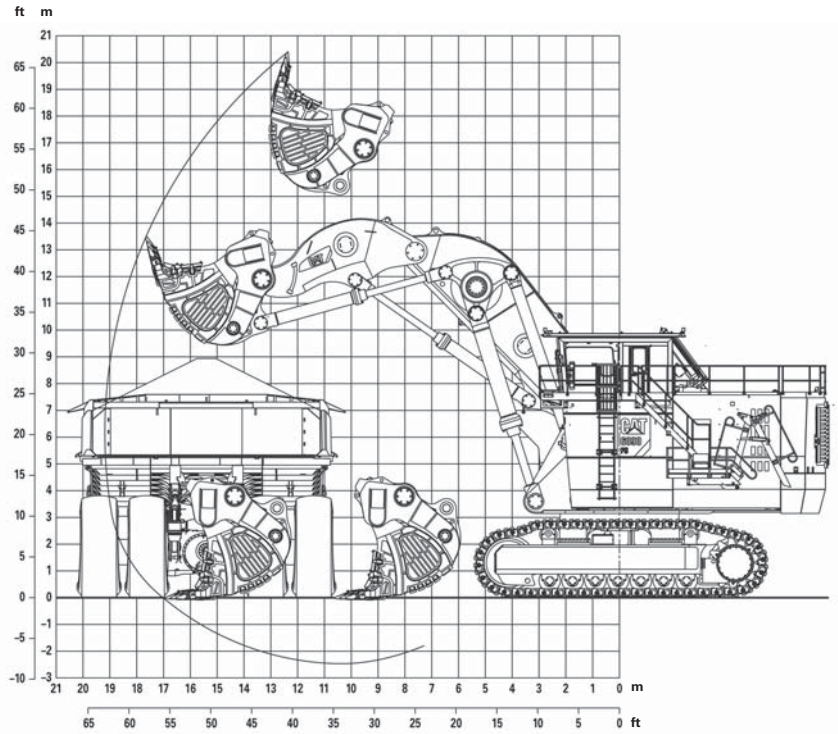

**MODEL**

**6090 FS**

**Working Range**

Maximum Digging Height	20.4 m	66'11"
Maximum Digging Reach	19.2 m	63'0"
Maximum Digging Depth	2.5 m	8'2"
Maximum Dumping Height	14.5 m	47'7"
Crowd Distance on Level	6.3 m	20'8"

**Digging Forces**

Maximum Crowd Force (arm cylinder)	3090 kN	694,420 lbf
Maximum Crowd Force at Ground Level (arm cylinder)	3080 kN	692,170 lbf
Maximum Breakout Force (bucket cylinder)	2420 kN	543,850 lbf

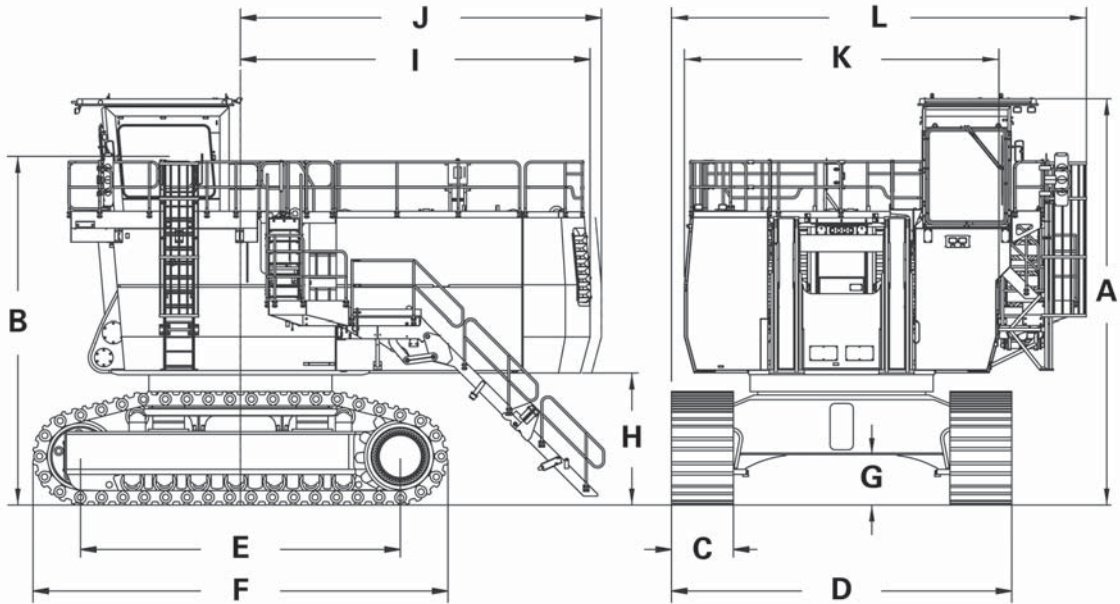

MODEL	6015B		6020B	
<b>A</b> Cab Height	4210 mm	13'10"	6430 mm	21'1"
<b>B</b> Operator's Eye Level, Approximate	3550 mm	11'8"	5500 mm	18'1"
<b>C</b> Width of Standard Track Shoe	700 mm	2'4"	800 mm	2'7"
<b>D</b> Track Width, Standard Shoe	4800 mm	15'9"	5500 mm	18'1"
<b>E</b> Track Length, Idler Center to Sprocket Center	5530 mm	18'2"	5810 mm	19'1"
<b>F</b> Overall Track Length, Grouser Bar to Grouser Bar	7000 mm	23'0"	7520 mm	24'8"
<b>G</b> Ground Clearance, Undercarriage Frame	1080 mm	3'7"	890 mm	2'11"
<b>H</b> Ground Clearance, Counterweight	1940 mm	6'4"	2095 mm	6'10"
<b>I</b> Tail Overhang	5120 mm	16'10"	5970 mm	19'7"
<b>J</b> Tail Swing Radius	5180 mm	17'0"	6045 mm	19'10"
<b>K</b> Counterweight Width	3650 mm	12'0"	6240 mm	20'6"
<b>L</b> Overall Width, Standard Shoe	5720 mm	18'9"	7850 mm	25'9"

NOTE: All measurements are based on the standard machine configuration.



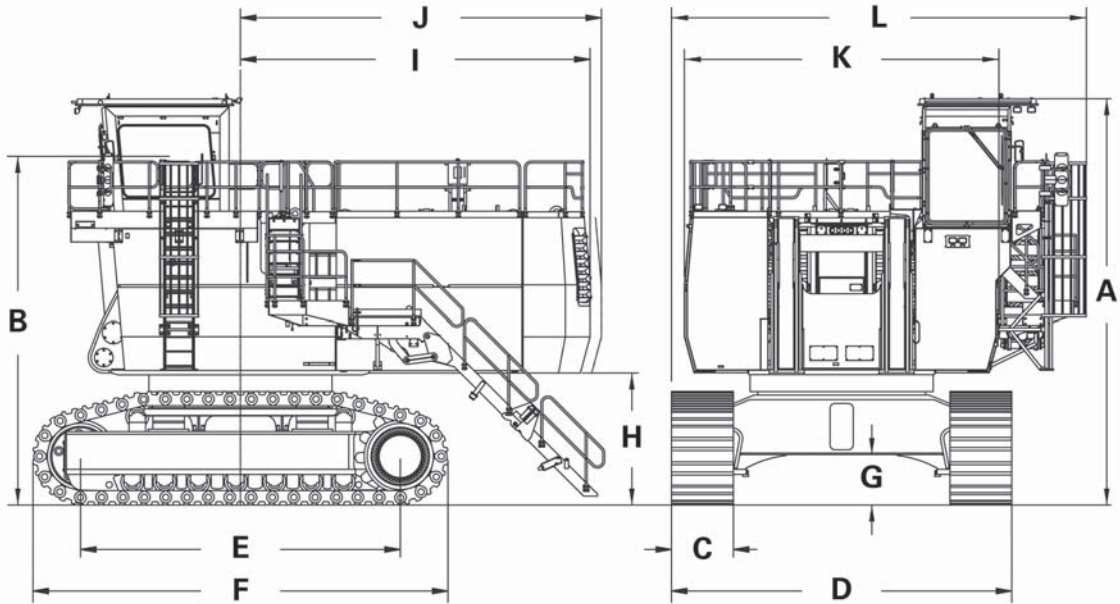

MODEL	6030/6030 FS		6040/6040 FS	
<b>A</b> Cab Height	7620 mm	25'0"	7920 mm	26'0"
<b>B</b> Operator's Eye Level, Approximate	6500 mm	21'4"	6780 mm	22'3"
<b>C</b> Width of Standard Track Shoe	1000 mm	3'3"	1200 mm	3'11"
<b>D</b> Track Width, Standard Shoe	5800 mm	19'0"	6600 mm	21'8"
<b>E</b> Track Length, Idler Center to Sprocket Center	6010 mm	19'9"	6170 mm	20'3"
<b>F</b> Overall Track Length, Grouser Bar to Grouser Bar	7660 mm	25'2"	8090 mm	26'7"
<b>G</b> Ground Clearance, Undercarriage Frame	880 mm	2'11"	1030 mm	3'5"
<b>H</b> Ground Clearance, Counterweight	2170 mm	7'1"	2620 mm	8'7"
<b>I</b> Tail Overhang	6310 mm	20'8"	6780 mm	22'3"
<b>J</b> Tail Swing Radius	6450 mm	21'2"	7000 mm	23'0"
<b>K</b> Counterweight Width	5300 mm	17'5"	6100 mm	20'0"
<b>L</b> Overall Width, Standard Shoe	7420 mm	24'4"	8050 mm	26'5"

**NOTE:** All measurements are based on the standard machine configuration.

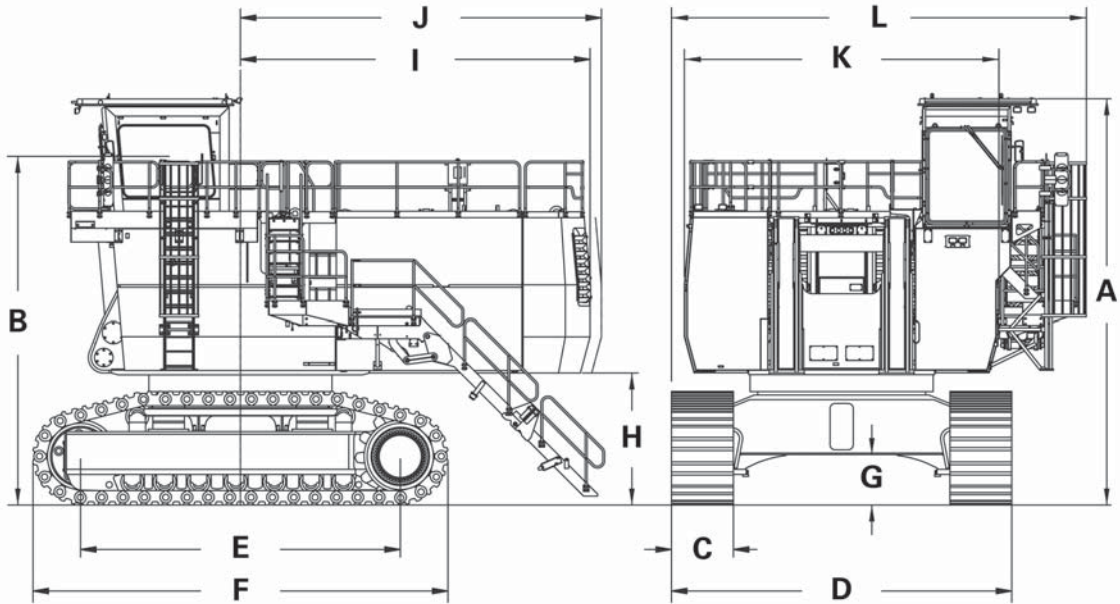

MODEL	6050/6050 FS		6060/6060 FS		6090 FS	
<b>A</b> Cab Height	8760 mm	28'9"	8790 mm	28'10"	9990 mm	32'9"
<b>B</b> Operator's Eye Level, Approximate	7600 mm	24'11"	7600 mm	24'11"	8800 mm	28'10"
<b>C</b> Width of Standard Track Shoe	1400 mm	4'7"	1400 mm	4'7"	2000 mm	6'7"
<b>D</b> Track Width, Standard Shoe	7000 mm	23'0"	7000 mm	23'0"	8600 mm	28'3"
<b>E</b> Track Length, Idler Center to Sprocket Center	6400 mm	21'0"	7090 mm	23'3"	8445 mm	27'8"
<b>F</b> Overall Track Length, Grouser Bar to Grouser Bar	8540 mm	28'0"	9230 mm	30'3"	10 980 mm	36'0"
<b>G</b> Ground Clearance, Undercarriage Frame	1120 mm	3'8"	1120 mm	3'8"	1135 mm	3'9"
<b>H</b> Ground Clearance, Counterweight	2790 mm	9'2"	2790 mm	9'2"	3150 mm	10'4"
<b>I</b> Tail Overhang	7350 mm	24'1"	7700 mm	25'3"	7800 mm	25'7"
<b>J</b> Tail Swing Radius	7580 mm	24'10"	7955 mm	26'1"	8050 mm	26'5"
<b>K</b> Counterweight Width	7000 mm	23'0"	7000 mm	23'0"	7600 mm	24'11"
<b>L</b> Overall Width, Standard Shoe	8430 mm	27'8"	8790 mm	28'10"	9720 mm	31'11"

NOTE: All measurements are based on the standard machine configuration.

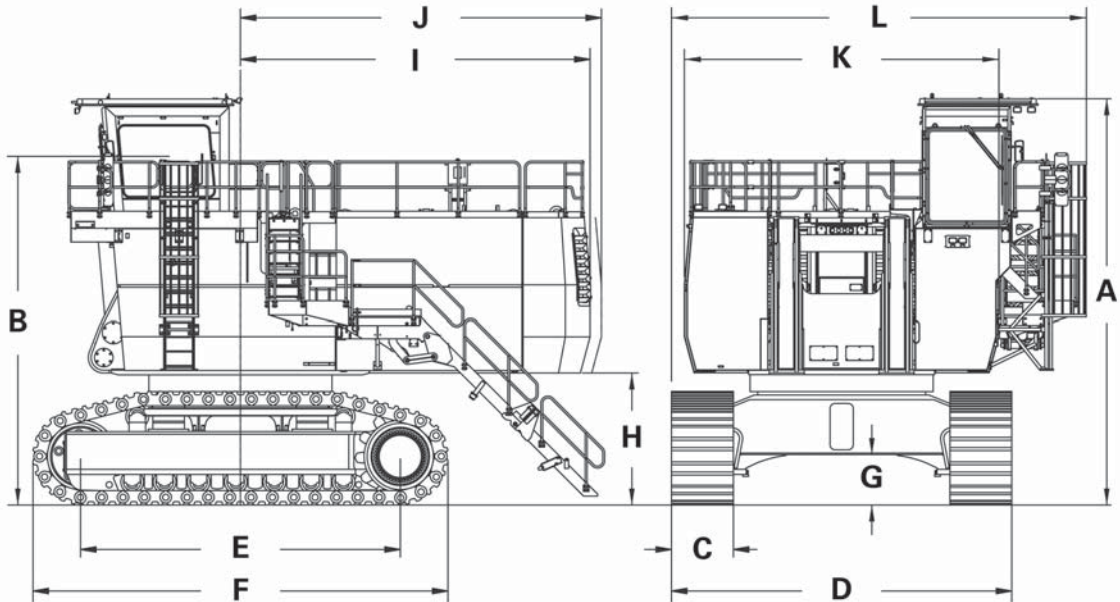

MODEL	6030 AC/ 6030 AC FS		6040 AC/ 6040 AC FS	
	mm	ft"	mm	ft"
<b>A</b> Cab Height	7620 mm	25'0"	7920 mm	26'0"
<b>B</b> Operator's Eye Level, Approximate	6500 mm	21'4"	6780 mm	22'3"
<b>C</b> Width of Standard Track Shoe	1000 mm	3'3"	1200 mm	3'11"
<b>D</b> Track Width, Standard Shoe	5800 mm	19'0"	6600 mm	21'8"
<b>E</b> Track Length, Idler Center to Sprocket Center	5980 mm	19'7"	6170 mm	20'3"
<b>F</b> Overall Track Length, Grouser Bar to Grouser Bar	7630 mm	25'0"	8090 mm	26'7"
<b>G</b> Ground Clearance, Undercarriage Frame	880 mm	2'11"	1030 mm	3'5"
<b>H</b> Ground Clearance, Counterweight	2170 mm	7'1"	2620 mm	8'7"
<b>I</b> Tail Overhang	6310 mm	20'8"	6780 mm	22'3"
<b>J</b> Tail Swing Radius	6450 mm	21'2"	7000 mm	23'0"
<b>K</b> Counterweight Width	5300 mm	17'5"	6100 mm	20'0"
<b>L</b> Overall Width, Standard Shoe	7110 mm	23'4"	7750 mm	25'5"

**NOTE:** All measurements are based on the standard machine configuration.

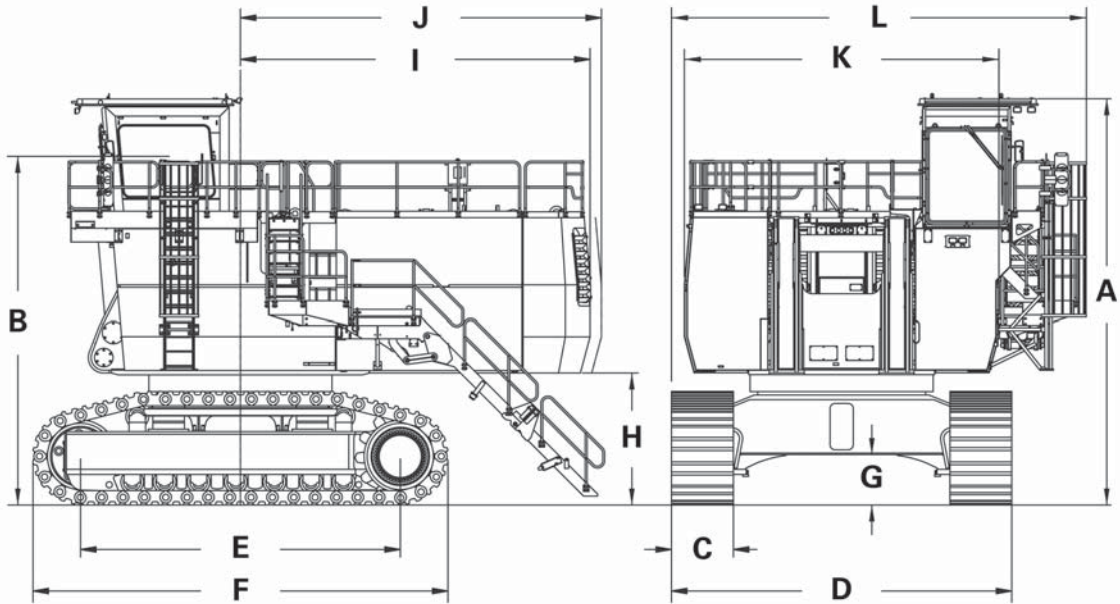

MODEL	6050 AC/ 6050 AC FS		6060 AC/ 6060 AC FS		6090 AC FS	
<b>A</b> Cab Height	8760 mm	28'9"	8730 mm	28'8"	9990 mm	32'9"
<b>B</b> Operator's Eye Level, Approximate	7600 mm	24'11"	7600 mm	24'11"	8800 mm	28'10"
<b>C</b> Width of Standard Track Shoe	1400 mm	4'7"	1400 mm	4'7"	2000 mm	6'7"
<b>D</b> Track Width, Standard Shoe	7000 mm	23'0"	7000 mm	23'0"	8600 mm	28'3"
<b>E</b> Track Length, Idler Center to Sprocket Center	6400 mm	21'0"	7090 mm	23'3"	8445 mm	27'8"
<b>F</b> Overall Track Length, Grouser Bar to Grouser Bar	8540 mm	28'0"	9230 mm	30'3"	10 980 mm	36'0"
<b>G</b> Ground Clearance, Undercarriage Frame	1120 mm	3'8"	1120 mm	3'8"	1135 mm	3'9"
<b>H</b> Ground Clearance, Counterweight	2790 mm	9'2"	2790 mm	9'2"	3150 mm	10'4"
<b>I</b> Tail Overhang	7350 mm	24'1"	7350 mm	24'1"	7800 mm	25'7"
<b>J</b> Tail Swing Radius	7580 mm	24'10"	7580 mm	24'10"	8050 mm	26'5"
<b>K</b> Counterweight Width	7000 mm	23'0"	7000 mm	23'0"	7600 mm	24'11"
<b>L</b> Overall Width, Standard Shoe	8730 mm	28'8"	8730 mm	28'8"	9720 mm	31'11"

NOTE: All measurements are based on the standard machine configuration.

**GROUND PRESSURE**

The ground pressure specifies the specific weight load transferred to the surface, and can be an indicator for the stability against subsidence. Though such conditions typically apply to smaller excavators in heavy earthmoving operations, there could be rare instances where this may apply in mining applications. Nevertheless, the vast majority of hydraulic mining shovels are delivered with standard track shoes.

The value is determined by setting the machine weight force in relation to the ground contact area of the tracks.

**Ground Contact Area**

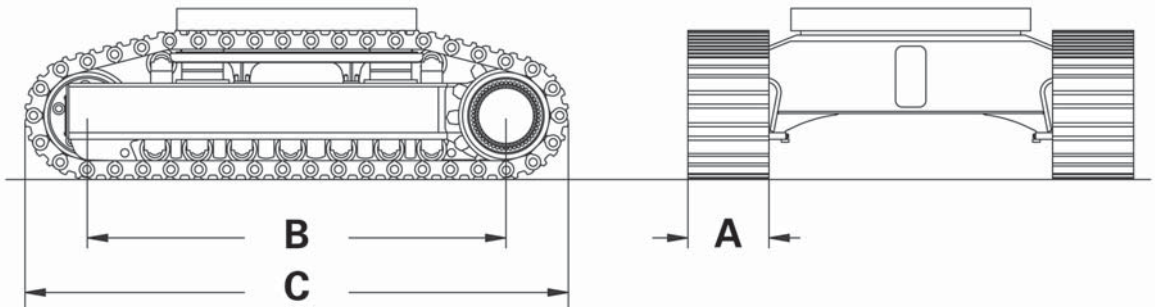

**Keys**

- A = Width of standard track shoe
- B = Track length, idler center to sprocket center
- C = Overall track length, grouser bar to grouser bar

To define the ground contact area on soft ground the following formula is applied:

$$2 \times A \times (B + (C - B) \times 0.35)$$

**Optional Track Pads**

In addition to the standard track shoes, optional track pads with different widths are available; however, these optional track pads are only procured on machine orders, and may therefore effect the lead time of the entire hydraulic mining shovel. Furthermore, a front shovel (FS) configured machine equipped with wider track pads increases the risk of track pad damage from bucket strikes.

- Backhoe Configurations
- Front Shovel Configurations

## Hydraulic Mining Shovels

### Backhoe Configurations

MODEL	Track Shoe Type	Width of Track Shoe [A]		Operating Weight		Ground Contact Area		Ground Pressure	
		mm	in	kg	lb	cm <sup>2</sup>	in <sup>2</sup>	N/cm <sup>2</sup>	psi
6015B	Standard	700	27.6	140 000	308,650	84 620	13,120	16.2	23.5
	Option 1	900	35.4	142 300	313,720	108 800	16,860	12.8	18.6
	Option 2	1000	39.4	143 500	316,360	120 890	18,740	11.6	16.9
6020B	Standard	800	31.5	230 500	508,160	102 540	15,890	22.1	32.0
6030	Option 1	800	31.5	294 300	648,810	105 400	16,340	27.4	39.7
	Standard	1000	39.4	296 500	653,660	131 750	20,420	22.1	32.0
	Option 2	1200	47.2	299 500	660,280	158 100	24,510	18.6	26.9
6040	Standard	1200	47.2	407 300	897,930	164 500	25,500	24.3	35.3
	Option 1	1400	55.1	410 300	904,550	191 930	29,750	21.0	30.4
	Option 2	1600	63.0	413 300	911,160	219 340	34,000	18.5	26.7
6050	Standard	1400	55.1	537 000	1,183,870	200 180	31,030	26.3	38.1
	Standard	1400	55.1	570 300	1,257,280	219 500	34,020	25.5	37.0

NOTE: All measurements are based on the standard machine configuration.

NOTE: All optional track shoes are long lead items.

### Front Shovel Configurations

MODEL	Track Shoe Type	Width of Track Shoe [A]		Operating Weight		Ground Contact Area		Ground Pressure	
		mm	in	kg	lb	cm <sup>2</sup>	in <sup>2</sup>	N/cm <sup>2</sup>	psi
6030 FS	Option 1	800	31.5	292 100	643,960	105 400	16,340	27.2	39.4
	Standard	1000	39.4	294 300	648,810	131 750	20,420	21.9	31.7
	Option 2	1200	47.2	297 300	655,430	158 100	24,510	18.4	26.7
6040 FS	Standard	1200	47.2	404 600	891,980	164 500	25,500	24.1	35.0
	Option 1	1400	55.1	407 600	898,590	191 930	29,750	20.8	30.2
	Option 2	1600	63.0	410 600	905,210	219 340	34,000	18.4	26.6
6050 FS	Standard	1400	55.1	527 600	1,163,150	200 180	31,030	25.9	37.5
6060 FS	Standard	1400	55.1	568 900	1,254,200	219 500	34,020	25.4	36.8
6090 FS	Option	1800	70.9	975 000	2,149,490	335 960	52,070	28.5	41.2
	Standard	2000	78.7	980 000	2,160,510	373 290	57,860	25.8	37.4

NOTE: All measurements are based on the standard machine configuration.

NOTE: All optional track shoes are long lead items.

# Hydraulic Mining Shovels

- Ground Pressures
- AC Units with Electric Drive
    - Backhoe Configurations
    - Front Shovel Configurations

## AC Units with Electric Drive — Backhoe Configurations

MODEL	Track Shoe Type	Width of Track Shoe [A]		Operating Weight		Ground Contact Area		Ground Pressure	
		mm	in	kg	lb	cm <sup>2</sup>	in <sup>2</sup>	N/cm <sup>2</sup>	psi
6030 AC	Option 1	800	31.5	294 300	648,810	105 400	16,340	27.4	39.7
	Standard	1000	39.4	296 500	653,660	131 750	20,420	22.1	32.0
	Option 2	1200	47.2	299 500	660,280	158 100	24,510	18.6	26.9
6040 AC	Standard	1200	47.2	407 000	897,270	164 500	25,500	24.3	35.1
	Option 1	1400	55.1	410 000	903,890	191 930	29,750	21.0	30.4
	Option 2	1600	63.0	413 000	910,500	219 340	34,000	18.5	26.7
6050 AC	Standard	1400	55.1	524 500	1,156,310	200 180	31,030	25.7	37.3
6060 AC	Standard	1400	55.1	547 700	1,207,460	219 500	34,020	24.5	35.6

NOTE: All measurements are based on the standard machine configuration.

NOTE: All optional track shoes are long lead items.

## AC Units with Electric Drive — Front Shovel Configurations

MODEL	Track Shoe Type	Width of Track Shoe [A]		Operating Weight		Ground Contact Area		Ground Pressure	
		mm	in	kg	lb	cm <sup>2</sup>	in <sup>2</sup>	N/cm <sup>2</sup>	psi
6030 AC FS	Option 1	800	31.5	292 100	643,960	105 400	16,340	27.2	39.4
	Standard	1000	39.4	294 300	648,810	131 750	20,420	21.9	31.7
	Option 2	1200	47.2	297 300	655,430	158 100	24,510	18.4	26.7
6040 AC FS	Standard	1200	47.2	404 300	891,320	164 500	25,500	24.1	35.0
	Option 1	1400	55.1	407 300	897,930	191 930	29,750	20.8	30.2
	Option 2	1600	63.0	410 300	904,550	219 340	34,000	18.4	26.6
6050 AC FS	Standard	1400	55.1	515 100	1,135,590	164 500	25,500	25.2	36.6
6060 AC FS	Standard	1400	55.1	546 300	1,204,370	219 500	34,020	24.4	35.4
6090 AC FS	Option	1800	70.9	950 000	2,094,370	335 960	52,070	27.7	40.3
	Standard	2000	78.7	955 000	2,105,390	373 290	57,860	25.1	36.4

NOTE: All measurements are based on the standard machine configuration.

NOTE: All optional track shoes are long lead items.

## BUCKET SELECTION

For the durability and life expectancy of hydraulic mining shovels, it is important to choose the correct bucket size based on the maximum loose density of the material to be loaded. Different bucket volumes for common material densities are available for most models. A loose density of  $1.8 \text{ t/m}^3$  ( $3030 \text{ lb/yd}^3$ ) is considered standard density and the respective bucket volume is suitable for the majority of applications. Additional volumes are offered in staggered increments of  $0.2 \text{ t/m}^3$  ( $340 \text{ lb/yd}^3$ ) and most of them are for heavier material.

### Rated Bucket Capacity

Basically, the total volume is a combination of the struck capacity plus a heap on top of it. On hydraulic mining shovels, the rated bucket capacity is calculated with a different angle of repose for the heap of backhoe buckets versus that of face shovel buckets. As the kinematics on backhoe machines allow for larger bucket tilt angles, steeper heaps are achieved compared to face shovel buckets. Therefore, the nominal bucket capacity is calculated on backhoe buckets with a heap of 1:1, and on face shovel buckets with a heap of 2:1 as shown exemplary in the adjacent sketch.

The following standards have been used to determine the rated bucket capacity:

ISO 7451 for backhoe buckets

ISO 7546 for face shovel buckets

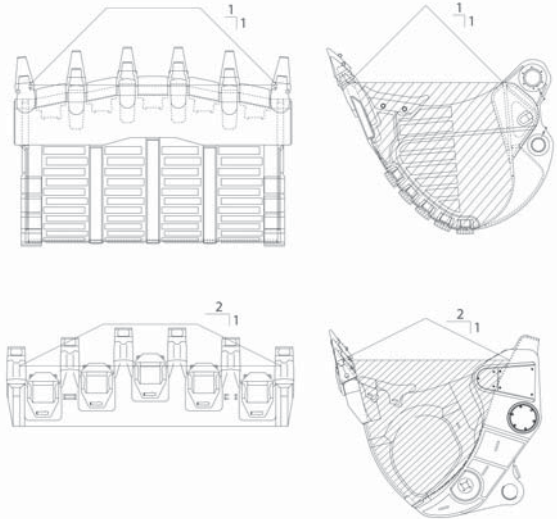

### Practical Bucket Capacity

Under real working conditions, the actual achieved bucket volume, over time, is generally lower when compared to the rated capacity. This is dependent upon various factors, such as fragmentation, bench or face height and humidity. An experienced, well-trained operator achieves between 90 to 95% in reasonably blasted material.



### CYCLE TIMES

The cycle time of a hydraulic mining shovel is an important productivity factor, and a key driver for high or low performance. There are two main areas that influence cycle times. One factor is the pure technical capability of the hydraulic mining shovel. The engine output and associated hydraulic power defines the maximum available oil flow, which consequently determines the speed of the hydraulic cylinders and swing drives, and ultimately the achievable working speed of the machine. The other factor is site specific parameters, such as operator skill, bench height (in particular for hydraulic front shovels), and swing angle, will impact cycle times considerably. Material fragmentation and penetration resistance make a big difference, as well.

Large hydraulic mining shovels are used as the prime mover in most applications. Therefore, the set-up of the loading area is pre-considered to be favorable for productive loading conditions when defining cycle times. Those are for example:

	For backhoe machines	For face shovel machines
Truck position	lower level	same level
Average swing angle	60°–90°	90°
Bench height	similar to stick length	75% of max. reach height

A complete working cycle of a hydraulic mining shovel can be separated into four segments:

- Bucket fill
- Swing loaded
- Dump
- Swing empty

However, the bucket fill process constitutes the main fraction of the loading cycle, with a portion between 40% and 50% of the total time. This is heavily influenced by the material parameters, therefore, the different cycle times, shown for each model in the attached diagram, only consider the increasing effort to fill the bucket:

- **Ideal loading conditions** — Loose material, such as dry sand, soil and gravel, or re-handled or tipped material with no effort to achieve a good fill. Bucket can penetrate anywhere in the face or pile without resistance.
- **Average loading conditions** — Soft overburden with low grade of compaction, and well-shot material with good and consistent fragmentation. Operator doesn't have to concentrate on loosening or finding the right spot for penetration.
- **Fair digging conditions** — Shot rock with partially interlocked sections, or compacted overburden, requiring some effort to loosen the material.
- **Difficult digging conditions** — Inhomogeneous shot rock with some oversized boulders and interlocking, or unblasted material. Also free digging applications in sediment type of rock with fractures and layers which allow to penetrate the material. Considerable effort required to break out material.
- **Severe digging conditions** — Poorly shot rock with a large amount of oversized boulders and/or heavily interlocked material in the majority of the face. Also free digging operations with high digging resistance. In those conditions neither cycle times nor bucket fills are predictable.

Cycle Time Estimating Chart

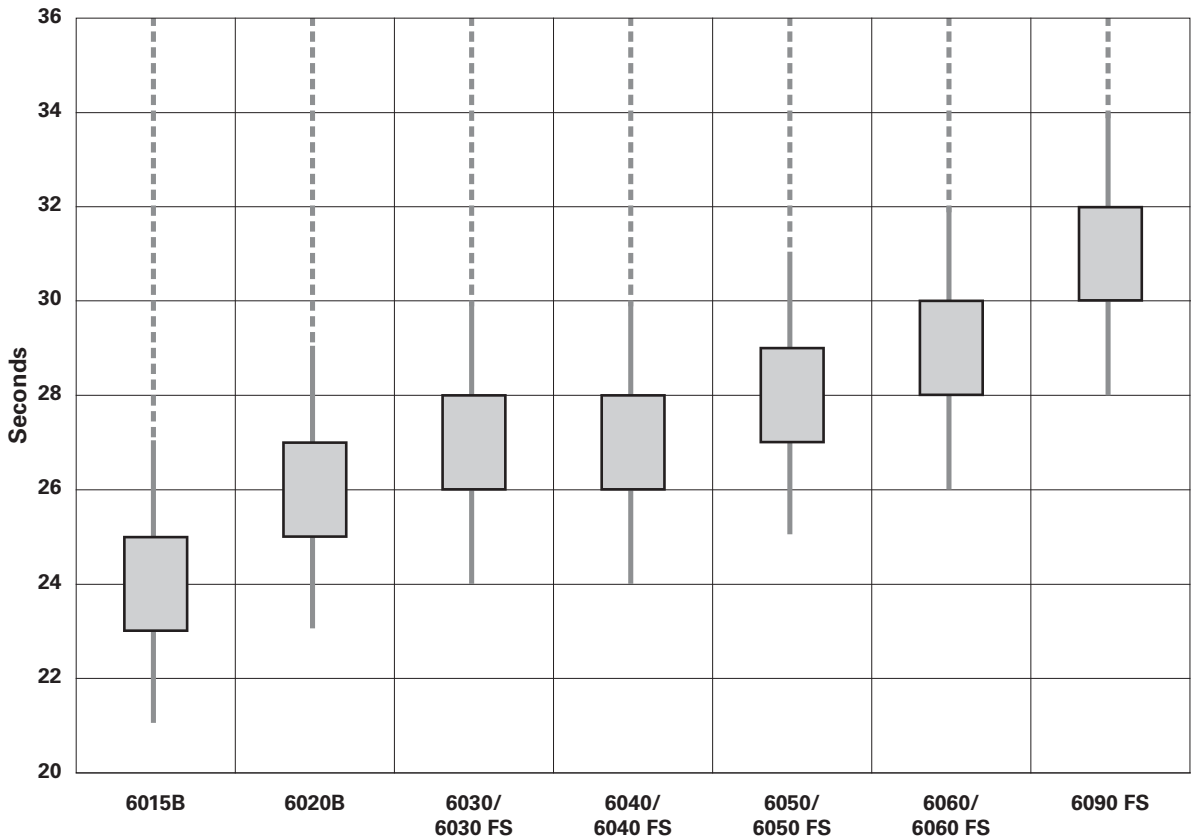

Key

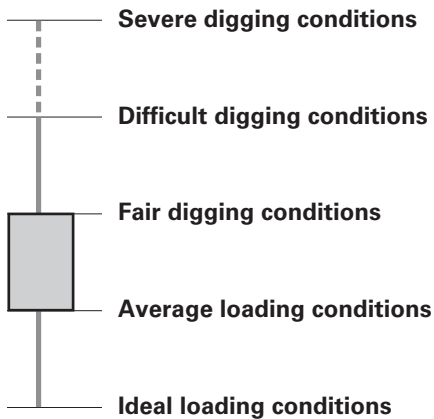

**NOTE:** The cycle times mentioned above are a guideline under the described application conditions.

Actual achievable cycle times depend on site specific conditions.

## **PRODUCTION OVERVIEWS**

As with any other piece of material handling equipment, the productivity of a hydraulic mining shovel depends on various aspects. These influencing factors are either defined by pure machine specifications, such as bucket capacity, or by application conditions and operator skills, like bucket fill factor and cycle time. In addition, there are parameters, which fall neither under the hydraulic mining shovel's physical capabilities, nor can they be controlled by the shovel operator or the set-up of the loading area. The major factors in this category are truck exchange time and overall mine efficiency.

The following tables indicate, for a typical hydraulic mining shovel/truck combination, the wide range of productivity figures in t/h (tons/h) under various conditions. The overall mine efficiency starts at 83%, which corresponds to 50 minutes per hour. This efficiency is generally achievable only during a short period of time, and could be the relevant factor for a short time production test. However, in the long-run, the overall mine efficiency tends to be in the 65% to 75% range. The grey highlighted area illustrates average productivity figures which can be expected under typical site conditions in well organized mines.

Furthermore, the size of the truck, and the required number of passes to load it, has an effect on hydraulic mining shovel productivity. The larger the truck, the higher the hydraulic mining shovel's productivity will be, because unproductive truck exchange time will be reduced.

The figures in the following tables given in t/h (tons/h) means the production per net loading hour and not per service meter units [SMU].

MODEL: 6015B ● Bucket Size: 8.1 m<sup>3</sup> ● Number of Cycles: 4 ● Material Density: 1.80 t/m<sup>3</sup>

Overall Mine Efficiency	Bucket Fill Factor		100%				95%			
	Load per Bucket		14.6 t				13.9 t			
	Load per Truck		58 t				55 t			
Truck Exchange	Cycle Time		21 sec	23 sec	25 sec	27 sec	21 sec	23 sec	25 sec	27 sec
	Truck Exchange		0.35 min	0.38 min	0.42 min	0.45 min	0.35 min	0.38 min	0.42 min	0.45 min
83% = maximum 50 min/hour	30 sec	0.50 min	1818 t/h	1721 t/h	1607 t/h	1531 t/h	1724 t/h	1633 t/h	1524 t/h	1452 t/h
	42 sec	0.70 min	1616 t/h	1539 t/h	1447 t/h	1385 t/h	1533 t/h	1460 t/h	1373 t/h	1314 t/h
	54 sec	0.90 min	1454 t/h	1392 t/h	1316 t/h	1264 t/h	1380 t/h	1320 t/h	1248 t/h	1200 t/h
	66 sec	1.10 min	1322 t/h	1270 t/h	1207 t/h	1163 t/h	1254 t/h	1205 t/h	1145 t/h	1104 t/h
80%	30 sec	0.50 min	1745 t/h	1652 t/h	1543 t/h	1470 t/h	1656 t/h	1568 t/h	1464 t/h	1394 t/h
	42 sec	0.70 min	1551 t/h	1478 t/h	1389 t/h	1330 t/h	1472 t/h	1402 t/h	1318 t/h	1262 t/h
	54 sec	0.90 min	1396 t/h	1336 t/h	1264 t/h	1214 t/h	1325 t/h	1268 t/h	1199 t/h	1152 t/h
	66 sec	1.10 min	1269 t/h	1220 t/h	1159 t/h	1117 t/h	1204 t/h	1157 t/h	1099 t/h	1060 t/h
75%	30 sec	0.50 min	1636 t/h	1549 t/h	1446 t/h	1378 t/h	1552 t/h	1469 t/h	1372 t/h	1307 t/h
	42 sec	0.70 min	1454 t/h	1385 t/h	1302 t/h	1246 t/h	1380 t/h	1314 t/h	1235 t/h	1182 t/h
	54 sec	0.90 min	1309 t/h	1252 t/h	1184 t/h	1138 t/h	1242 t/h	1188 t/h	1124 t/h	1080 t/h
	66 sec	1.10 min	1190 t/h	1143 t/h	1086 t/h	1047 t/h	1129 t/h	1084 t/h	1030 t/h	993 t/h
70%	30 sec	0.50 min	1526 t/h	1445 t/h	1349 t/h	1285 t/h	1448 t/h	1371 t/h	1280 t/h	1219 t/h
	42 sec	0.70 min	1357 t/h	1292 t/h	1215 t/h	1163 t/h	1287 t/h	1226 t/h	1153 t/h	1103 t/h
	54 sec	0.90 min	1221 t/h	1169 t/h	1105 t/h	1062 t/h	1158 t/h	1109 t/h	1048 t/h	1007 t/h
	66 sec	1.10 min	1110 t/h	1067 t/h	1013 t/h	977 t/h	1053 t/h	1012 t/h	961 t/h	927 t/h
65%	30 sec	0.50 min	1417 t/h	1341 t/h	1253 t/h	1193 t/h	1344 t/h	1273 t/h	1188 t/h	1132 t/h
	42 sec	0.70 min	1259 t/h	1200 t/h	1128 t/h	1080 t/h	1195 t/h	1138 t/h	1070 t/h	1024 t/h
	54 sec	0.90 min	1134 t/h	1085 t/h	1026 t/h	986 t/h	1075 t/h	1029 t/h	973 t/h	935 t/h
	66 sec	1.10 min	1030 t/h	990 t/h	941 t/h	907 t/h	978 t/h	939 t/h	892 t/h	860 t/h

Overall Mine Efficiency	Bucket Fill Factor		90%				85%			
	Load per Bucket		13.1 t				12.4 t			
	Load per Truck		52 t				50 t			
Truck Exchange	Cycle Time		21 sec	23 sec	25 sec	27 sec	21 sec	23 sec	25 sec	27 sec
	Truck Exchange		0.35 min	0.38 min	0.42 min	0.45 min	0.35 min	0.38 min	0.42 min	0.45 min
83% = maximum 50 min/hour	30 sec	0.50 min	1634 t/h	1547 t/h	1444 t/h	1376 t/h	1543 t/h	1461 t/h	1364 t/h	1299 t/h
	42 sec	0.70 min	1452 t/h	1383 t/h	1300 t/h	1245 t/h	1371 t/h	1306 t/h	1228 t/h	1176 t/h
	54 sec	0.90 min	1307 t/h	1251 t/h	1183 t/h	1136 t/h	1234 t/h	1181 t/h	1117 t/h	1073 t/h
	66 sec	1.10 min	1188 t/h	1141 t/h	1085 t/h	1046 t/h	1122 t/h	1078 t/h	1024 t/h	987 t/h
80%	30 sec	0.50 min	1569 t/h	1485 t/h	1387 t/h	1321 t/h	1482 t/h	1403 t/h	1310 t/h	1248 t/h
	42 sec	0.70 min	1394 t/h	1328 t/h	1249 t/h	1195 t/h	1317 t/h	1254 t/h	1179 t/h	1129 t/h
	54 sec	0.90 min	1255 t/h	1201 t/h	1136 t/h	1091 t/h	1185 t/h	1134 t/h	1073 t/h	1031 t/h
	66 sec	1.10 min	1141 t/h	1096 t/h	1041 t/h	1004 t/h	1078 t/h	1035 t/h	984 t/h	948 t/h
75%	30 sec	0.50 min	1470 t/h	1392 t/h	1300 t/h	1238 t/h	1389 t/h	1315 t/h	1228 t/h	1169 t/h
	42 sec	0.70 min	1307 t/h	1245 t/h	1170 t/h	1120 t/h	1234 t/h	1176 t/h	1105 t/h	1058 t/h
	54 sec	0.90 min	1176 t/h	1126 t/h	1064 t/h	1023 t/h	1111 t/h	1063 t/h	1005 t/h	966 t/h
	66 sec	1.10 min	1069 t/h	1027 t/h	976 t/h	941 t/h	1010 t/h	970 t/h	922 t/h	889 t/h
70%	30 sec	0.50 min	1372 t/h	1299 t/h	1213 t/h	1155 t/h	1296 t/h	1227 t/h	1145 t/h	1091 t/h
	42 sec	0.70 min	1219 t/h	1161 t/h	1092 t/h	1045 t/h	1152 t/h	1097 t/h	1031 t/h	987 t/h
	54 sec	0.90 min	1098 t/h	1050 t/h	993 t/h	954 t/h	1037 t/h	992 t/h	938 t/h	901 t/h
	66 sec	1.10 min	998 t/h	959 t/h	911 t/h	878 t/h	942 t/h	905 t/h	860 t/h	829 t/h
65%	30 sec	0.50 min	1273 t/h	1206 t/h	1126 t/h	1072 t/h	1203 t/h	1139 t/h	1063 t/h	1013 t/h
	42 sec	0.70 min	1132 t/h	1078 t/h	1014 t/h	970 t/h	1069 t/h	1018 t/h	957 t/h	916 t/h
	54 sec	0.90 min	1019 t/h	975 t/h	922 t/h	886 t/h	962 t/h	921 t/h	871 t/h	837 t/h
	66 sec	1.10 min	926 t/h	890 t/h	845 t/h	815 t/h	875 t/h	840 t/h	799 t/h	770 t/h

**MODEL: 6015B ● Bucket Size: 10.6 yd<sup>3</sup> ● Number of Cycles: 4 ● Material Density: 3030 lb/yd<sup>3</sup>**

Overall Mine Efficiency	Bucket Fill Factor		100%				95%			
	Load per Bucket		16.1 tons				15.3 tons			
	Load per Truck		64 tons				61 tons			
Truck Exchange	Cycle Time		21 sec	23 sec	25 sec	27 sec	21 sec	23 sec	25 sec	27 sec
	30 sec	0.50 min	0.35 min	0.38 min	0.42 min	0.45 min	0.35 min	0.38 min	0.42 min	0.45 min
83% = maximum 50 min/hour	30 sec	0.50 min	2004 tons/h	1897 tons/h	1771 tons/h	1687 tons/h	1901 tons/h	1800 tons/h	1680 tons/h	1601 tons/h
	42 sec	0.70 min	1781 tons/h	1696 tons/h	1595 tons/h	1527 tons/h	1690 tons/h	1609 tons/h	1513 tons/h	1448 tons/h
	54 sec	0.90 min	1603 tons/h	1534 tons/h	1451 tons/h	1394 tons/h	1521 tons/h	1455 tons/h	1376 tons/h	1322 tons/h
	66 sec	1.10 min	1457 tons/h	1400 tons/h	1330 tons/h	1282 tons/h	1382 tons/h	1328 tons/h	1262 tons/h	1217 tons/h
80%	30 sec	0.50 min	1924 tons/h	1822 tons/h	1701 tons/h	1620 tons/h	1825 tons/h	1728 tons/h	1614 tons/h	1537 tons/h
	42 sec	0.70 min	1710 tons/h	1629 tons/h	1532 tons/h	1466 tons/h	1622 tons/h	1545 tons/h	1453 tons/h	1391 tons/h
	54 sec	0.90 min	1539 tons/h	1473 tons/h	1393 tons/h	1338 tons/h	1460 tons/h	1397 tons/h	1321 tons/h	1270 tons/h
	66 sec	1.10 min	1399 tons/h	1344 tons/h	1277 tons/h	1231 tons/h	1327 tons/h	1275 tons/h	1212 tons/h	1168 tons/h
75%	30 sec	0.50 min	1803 tons/h	1707 tons/h	1594 tons/h	1519 tons/h	1711 tons/h	1620 tons/h	1512 tons/h	1441 tons/h
	42 sec	0.70 min	1603 tons/h	1527 tons/h	1435 tons/h	1374 tons/h	1521 tons/h	1448 tons/h	1362 tons/h	1303 tons/h
	54 sec	0.90 min	1443 tons/h	1381 tons/h	1306 tons/h	1254 tons/h	1369 tons/h	1310 tons/h	1239 tons/h	1190 tons/h
	66 sec	1.10 min	1311 tons/h	1260 tons/h	1197 tons/h	1154 tons/h	1244 tons/h	1195 tons/h	1136 tons/h	1095 tons/h
70%	30 sec	0.50 min	1683 tons/h	1593 tons/h	1487 tons/h	1417 tons/h	1596 tons/h	1511 tons/h	1411 tons/h	1344 tons/h
	42 sec	0.70 min	1496 tons/h	1424 tons/h	1339 tons/h	1282 tons/h	1419 tons/h	1351 tons/h	1271 tons/h	1216 tons/h
	54 sec	0.90 min	1346 tons/h	1288 tons/h	1218 tons/h	1171 tons/h	1277 tons/h	1222 tons/h	1156 tons/h	1110 tons/h
	66 sec	1.10 min	1224 tons/h	1176 tons/h	1117 tons/h	1077 tons/h	1161 tons/h	1115 tons/h	1060 tons/h	1022 tons/h
65%	30 sec	0.50 min	1562 tons/h	1479 tons/h	1381 tons/h	1315 tons/h	1482 tons/h	1403 tons/h	1310 tons/h	1248 tons/h
	42 sec	0.70 min	1388 tons/h	1322 tons/h	1243 tons/h	1190 tons/h	1317 tons/h	1254 tons/h	1180 tons/h	1129 tons/h
	54 sec	0.90 min	1250 tons/h	1196 tons/h	1131 tons/h	1087 tons/h	1185 tons/h	1134 tons/h	1073 tons/h	1031 tons/h
	66 sec	1.10 min	1136 tons/h	1091 tons/h	1037 tons/h	1000 tons/h	1078 tons/h	1035 tons/h	984 tons/h	948 tons/h

Overall Mine Efficiency	Bucket Fill Factor		90%				85%			
	Load per Bucket		14.5 tons				13.7 tons			
	Load per Truck		58 tons				55 tons			
Truck Exchange	Cycle Time		21 sec	23 sec	25 sec	27 sec	21 sec	23 sec	25 sec	27 sec
	30 sec	0.50 min	0.35 min	0.38 min	0.42 min	0.45 min	0.35 min	0.38 min	0.42 min	0.45 min
83% = maximum 50 min/hour	30 sec	0.50 min	1801 tons/h	1705 tons/h	1592 tons/h	1516 tons/h	1701 tons/h	1610 tons/h	1503 tons/h	1432 tons/h
	42 sec	0.70 min	1601 tons/h	1525 tons/h	1433 tons/h	1372 tons/h	1512 tons/h	1440 tons/h	1354 tons/h	1296 tons/h
	54 sec	0.90 min	1441 tons/h	1379 tons/h	1304 tons/h	1253 tons/h	1361 tons/h	1302 tons/h	1231 tons/h	1183 tons/h
	66 sec	1.10 min	1310 tons/h	1258 tons/h	1196 tons/h	1153 tons/h	1237 tons/h	1188 tons/h	1129 tons/h	1089 tons/h
80%	30 sec	0.50 min	1729 tons/h	1637 tons/h	1529 tons/h	1456 tons/h	1633 tons/h	1546 tons/h	1444 tons/h	1375 tons/h
	42 sec	0.70 min	1537 tons/h	1464 tons/h	1377 tons/h	1318 tons/h	1452 tons/h	1383 tons/h	1300 tons/h	1244 tons/h
	54 sec	0.90 min	1383 tons/h	1324 tons/h	1252 tons/h	1203 tons/h	1307 tons/h	1250 tons/h	1182 tons/h	1136 tons/h
	66 sec	1.10 min	1258 tons/h	1208 tons/h	1148 tons/h	1107 tons/h	1188 tons/h	1141 tons/h	1084 tons/h	1045 tons/h
75%	30 sec	0.50 min	1621 tons/h	1534 tons/h	1433 tons/h	1365 tons/h	1531 tons/h	1449 tons/h	1353 tons/h	1289 tons/h
	42 sec	0.70 min	1441 tons/h	1372 tons/h	1290 tons/h	1235 tons/h	1361 tons/h	1296 tons/h	1218 tons/h	1166 tons/h
	54 sec	0.90 min	1297 tons/h	1241 tons/h	1173 tons/h	1127 tons/h	1225 tons/h	1172 tons/h	1108 tons/h	1065 tons/h
	66 sec	1.10 min	1179 tons/h	1132 tons/h	1076 tons/h	1037 tons/h	1113 tons/h	1069 tons/h	1016 tons/h	980 tons/h
70%	30 sec	0.50 min	1512 tons/h	1432 tons/h	1337 tons/h	1273 tons/h	1428 tons/h	1352 tons/h	1263 tons/h	1203 tons/h
	42 sec	0.70 min	1344 tons/h	1280 tons/h	1204 tons/h	1152 tons/h	1270 tons/h	1209 tons/h	1137 tons/h	1088 tons/h
	54 sec	0.90 min	1210 tons/h	1158 tons/h	1095 tons/h	1052 tons/h	1143 tons/h	1093 tons/h	1034 tons/h	994 tons/h
	66 sec	1.10 min	1100 tons/h	1057 tons/h	1004 tons/h	968 tons/h	1039 tons/h	998 tons/h	948 tons/h	914 tons/h
65%	30 sec	0.50 min	1404 tons/h	1329 tons/h	1241 tons/h	1182 tons/h	1326 tons/h	1255 tons/h	1172 tons/h	1116 tons/h
	42 sec	0.70 min	1248 tons/h	1188 tons/h	1117 tons/h	1070 tons/h	1178 tons/h	1122 tons/h	1055 tons/h	1010 tons/h
	54 sec	0.90 min	1123 tons/h	1075 tons/h	1016 tons/h	977 tons/h	1061 tons/h	1015 tons/h	960 tons/h	922 tons/h
	66 sec	1.10 min	1021 tons/h	981 tons/h	932 tons/h	898 tons/h	964 tons/h	926 tons/h	880 tons/h	849 tons/h

MODEL: 6020B ● Bucket Size: 12.0 m<sup>3</sup> ● Number of Cycles: 4 ● Material Density: 1.80 t/m<sup>3</sup>

Overall Mine Efficiency	Bucket Fill Factor		100%				95%			
	Load per Bucket		21.6 t				20.5 t			
	Load per Truck		86 t				82 t			
Truck Exchange	Cycle Time		23 sec	25 sec	27 sec	29 sec	23 sec	25 sec	27 sec	29 sec
	Truck Exchange		0.38 min	0.42 min	0.45 min	0.48 min	0.38 min	0.42 min	0.45 min	0.48 min
83% = maximum 50 min/hour	30 sec	0.50 min	2546 t/h	2377 t/h	2265 t/h	2162 t/h	2419 t/h	2258 t/h	2151 t/h	2054 t/h
	42 sec	0.70 min	2277 t/h	2141 t/h	2049 t/h	1965 t/h	2163 t/h	2034 t/h	1946 t/h	1866 t/h
	54 sec	0.90 min	2059 t/h	1947 t/h	1871 t/h	1800 t/h	1956 t/h	1850 t/h	1777 t/h	1710 t/h
	66 sec	1.10 min	1879 t/h	1785 t/h	1721 t/h	1661 t/h	1785 t/h	1696 t/h	1635 t/h	1578 t/h
80%	30 sec	0.50 min	2445 t/h	2283 t/h	2175 t/h	2076 t/h	2323 t/h	2169 t/h	2066 t/h	1972 t/h
	42 sec	0.70 min	2186 t/h	2056 t/h	1967 t/h	1887 t/h	2077 t/h	1953 t/h	1869 t/h	1792 t/h
	54 sec	0.90 min	1977 t/h	1870 t/h	1796 t/h	1729 t/h	1878 t/h	1776 t/h	1707 t/h	1642 t/h
	66 sec	1.10 min	1804 t/h	1714 t/h	1653 t/h	1595 t/h	1714 t/h	1629 t/h	1570 t/h	1515 t/h
75%	30 sec	0.50 min	2291 t/h	2139 t/h	2038 t/h	1946 t/h	2177 t/h	2033 t/h	1936 t/h	1849 t/h
	42 sec	0.70 min	2049 t/h	1927 t/h	1844 t/h	1768 t/h	1946 t/h	1830 t/h	1752 t/h	1680 t/h
	54 sec	0.90 min	1853 t/h	1752 t/h	1684 t/h	1620 t/h	1760 t/h	1665 t/h	1599 t/h	1539 t/h
	66 sec	1.10 min	1691 t/h	1607 t/h	1549 t/h	1495 t/h	1606 t/h	1526 t/h	1472 t/h	1420 t/h
70%	30 sec	0.50 min	2138 t/h	1996 t/h	1902 t/h	1816 t/h	2031 t/h	1896 t/h	1807 t/h	1725 t/h
	42 sec	0.70 min	1912 t/h	1798 t/h	1721 t/h	1650 t/h	1816 t/h	1708 t/h	1635 t/h	1567 t/h
	54 sec	0.90 min	1729 t/h	1635 t/h	1571 t/h	1512 t/h	1642 t/h	1553 t/h	1492 t/h	1436 t/h
	66 sec	1.10 min	1578 t/h	1499 t/h	1445 t/h	1395 t/h	1499 t/h	1424 t/h	1373 t/h	1325 t/h
65%	30 sec	0.50 min	1985 t/h	1853 t/h	1765 t/h	1685 t/h	1885 t/h	1760 t/h	1677 t/h	1601 t/h
	42 sec	0.70 min	1775 t/h	1669 t/h	1597 t/h	1532 t/h	1686 t/h	1585 t/h	1517 t/h	1455 t/h
	54 sec	0.90 min	1605 t/h	1518 t/h	1458 t/h	1403 t/h	1525 t/h	1442 t/h	1385 t/h	1333 t/h
	66 sec	1.10 min	1465 t/h	1392 t/h	1342 t/h	1295 t/h	1391 t/h	1322 t/h	1275 t/h	1230 t/h

Overall Mine Efficiency	Bucket Fill Factor		90%				85%			
	Load per Bucket		19.4 t				18.4 t			
	Load per Truck		78 t				73 t			
Truck Exchange	Cycle Time		23 sec	25 sec	27 sec	29 sec	23 sec	25 sec	27 sec	29 sec
	Truck Exchange		0.38 min	0.42 min	0.45 min	0.48 min	0.38 min	0.42 min	0.45 min	0.48 min
83% = maximum 50 min/hour	30 sec	0.50 min	2291 t/h	2139 t/h	2038 t/h	1946 t/h	2164 t/h	2021 t/h	1925 t/h	1838 t/h
	42 sec	0.70 min	2049 t/h	1927 t/h	1844 t/h	1768 t/h	1935 t/h	1820 t/h	1742 t/h	1670 t/h
	54 sec	0.90 min	1853 t/h	1752 t/h	1684 t/h	1620 t/h	1750 t/h	1655 t/h	1590 t/h	1530 t/h
	66 sec	1.10 min	1691 t/h	1607 t/h	1549 t/h	1495 t/h	1597 t/h	1518 t/h	1463 t/h	1412 t/h
80%	30 sec	0.50 min	2200 t/h	2054 t/h	1957 t/h	1869 t/h	2078 t/h	1940 t/h	1848 t/h	1765 t/h
	42 sec	0.70 min	1967 t/h	1850 t/h	1771 t/h	1698 t/h	1858 t/h	1747 t/h	1672 t/h	1604 t/h
	54 sec	0.90 min	1779 t/h	1683 t/h	1617 t/h	1556 t/h	1680 t/h	1589 t/h	1527 t/h	1469 t/h
	66 sec	1.10 min	1624 t/h	1543 t/h	1487 t/h	1436 t/h	1534 t/h	1457 t/h	1405 t/h	1356 t/h
75%	30 sec	0.50 min	2062 t/h	1926 t/h	1834 t/h	1751 t/h	1948 t/h	1819 t/h	1732 t/h	1654 t/h
	42 sec	0.70 min	1844 t/h	1734 t/h	1660 t/h	1591 t/h	1742 t/h	1638 t/h	1567 t/h	1503 t/h
	54 sec	0.90 min	1668 t/h	1577 t/h	1515 t/h	1458 t/h	1575 t/h	1489 t/h	1431 t/h	1377 t/h
	66 sec	1.10 min	1522 t/h	1446 t/h	1394 t/h	1346 t/h	1437 t/h	1366 t/h	1317 t/h	1271 t/h
70%	30 sec	0.50 min	1924 t/h	1797 t/h	1712 t/h	1634 t/h	1817 t/h	1697 t/h	1616 t/h	1543 t/h
	42 sec	0.70 min	1721 t/h	1618 t/h	1549 t/h	1485 t/h	1625 t/h	1528 t/h	1463 t/h	1402 t/h
	54 sec	0.90 min	1556 t/h	1471 t/h	1414 t/h	1361 t/h	1470 t/h	1390 t/h	1335 t/h	1285 t/h
	66 sec	1.10 min	1420 t/h	1349 t/h	1301 t/h	1256 t/h	1341 t/h	1274 t/h	1229 t/h	1186 t/h
65%	30 sec	0.50 min	1786 t/h	1668 t/h	1589 t/h	1517 t/h	1687 t/h	1575 t/h	1500 t/h	1433 t/h
	42 sec	0.70 min	1597 t/h	1502 t/h	1437 t/h	1378 t/h	1508 t/h	1418 t/h	1358 t/h	1302 t/h
	54 sec	0.90 min	1444 t/h	1366 t/h	1312 t/h	1263 t/h	1364 t/h	1290 t/h	1240 t/h	1193 t/h
	66 sec	1.10 min	1318 t/h	1253 t/h	1207 t/h	1165 t/h	1245 t/h	1183 t/h	1140 t/h	1101 t/h

**MODEL: 6020B ● Bucket Size: 15.7 yd<sup>3</sup> ● Number of Cycles: 4 ● Material Density: 3030 lb/yd<sup>3</sup>**

		Bucket Fill Factor		100%				95%			
		Load per Bucket		23.8 tons				22.6 tons			
		Load per Truck		95 tons				90 tons			
Overall Mine Efficiency	Truck Exchange	Cycle Time		23 sec	25 sec	27 sec	29 sec	23 sec	25 sec	27 sec	29 sec
		0.38 min	0.42 min	0.45 min	0.48 min	0.38 min	0.42 min	0.45 min	0.48 min		
83% = maximum 50 min/hour	30 sec	0.50 min	2806 tons/h	2620 tons/h	2496 tons/h	2383 tons/h	2666 tons/h	2489 tons/h	2371 tons/h	2264 tons/h	
	42 sec	0.70 min	2509 tons/h	2360 tons/h	2259 tons/h	2166 tons/h	2384 tons/h	2242 tons/h	2146 tons/h	2057 tons/h	
	54 sec	0.90 min	2269 tons/h	2146 tons/h	2062 tons/h	1984 tons/h	2156 tons/h	2039 tons/h	1959 tons/h	1885 tons/h	
	66 sec	1.10 min	2071 tons/h	1968 tons/h	1897 tons/h	1831 tons/h	1968 tons/h	1870 tons/h	1802 tons/h	1740 tons/h	
80%	30 sec	0.50 min	2695 tons/h	2516 tons/h	2397 tons/h	2289 tons/h	2560 tons/h	2390 tons/h	2277 tons/h	2174 tons/h	
	42 sec	0.70 min	2410 tons/h	2266 tons/h	2169 tons/h	2080 tons/h	2289 tons/h	2153 tons/h	2060 tons/h	1976 tons/h	
	54 sec	0.90 min	2179 tons/h	2061 tons/h	1980 tons/h	1906 tons/h	2070 tons/h	1958 tons/h	1881 tons/h	1810 tons/h	
	66 sec	1.10 min	1989 tons/h	1890 tons/h	1822 tons/h	1758 tons/h	1889 tons/h	1795 tons/h	1731 tons/h	1671 tons/h	
75%	30 sec	0.50 min	2526 tons/h	2358 tons/h	2247 tons/h	2145 tons/h	2400 tons/h	2240 tons/h	2134 tons/h	2038 tons/h	
	42 sec	0.70 min	2259 tons/h	2124 tons/h	2033 tons/h	1949 tons/h	2146 tons/h	2018 tons/h	1931 tons/h	1852 tons/h	
	54 sec	0.90 min	2042 tons/h	1932 tons/h	1856 tons/h	1786 tons/h	1940 tons/h	1835 tons/h	1763 tons/h	1697 tons/h	
	66 sec	1.10 min	1864 tons/h	1771 tons/h	1707 tons/h	1648 tons/h	1771 tons/h	1683 tons/h	1622 tons/h	1566 tons/h	
70%	30 sec	0.50 min	2357 tons/h	2201 tons/h	2096 tons/h	2001 tons/h	2239 tons/h	2090 tons/h	1991 tons/h	1901 tons/h	
	42 sec	0.70 min	2107 tons/h	1982 tons/h	1897 tons/h	1819 tons/h	2002 tons/h	1882 tons/h	1802 tons/h	1728 tons/h	
	54 sec	0.90 min	1906 tons/h	1802 tons/h	1732 tons/h	1666 tons/h	1810 tons/h	1712 tons/h	1645 tons/h	1583 tons/h	
	66 sec	1.10 min	1739 tons/h	1653 tons/h	1593 tons/h	1538 tons/h	1652 tons/h	1570 tons/h	1514 tons/h	1461 tons/h	
65%	30 sec	0.50 min	2188 tons/h	2043 tons/h	1946 tons/h	1858 tons/h	2078 tons/h	1941 tons/h	1849 tons/h	1765 tons/h	
	42 sec	0.70 min	1956 tons/h	1839 tons/h	1761 tons/h	1688 tons/h	1858 tons/h	1747 tons/h	1673 tons/h	1604 tons/h	
	54 sec	0.90 min	1769 tons/h	1673 tons/h	1607 tons/h	1547 tons/h	1681 tons/h	1589 tons/h	1527 tons/h	1470 tons/h	
	66 sec	1.10 min	1614 tons/h	1534 tons/h	1479 tons/h	1427 tons/h	1534 tons/h	1457 tons/h	1405 tons/h	1356 tons/h	

		Bucket Fill Factor		90%				85%			
		Load per Bucket		21.4 tons				20.2 tons			
		Load per Truck		86 tons				81 tons			
Overall Mine Efficiency	Truck Exchange	Cycle Time		23 sec	25 sec	27 sec	29 sec	23 sec	25 sec	27 sec	29 sec
		0.38 min	0.42 min	0.45 min	0.48 min	0.38 min	0.42 min	0.45 min	0.48 min		
83% = maximum 50 min/hour	30 sec	0.50 min	2526 tons/h	2358 tons/h	2247 tons/h	2145 tons/h	2386 tons/h	2227 tons/h	2122 tons/h	2026 tons/h	
	42 sec	0.70 min	2259 tons/h	2124 tons/h	2033 tons/h	1949 tons/h	2133 tons/h	2006 tons/h	1920 tons/h	1841 tons/h	
	54 sec	0.90 min	2042 tons/h	1932 tons/h	1856 tons/h	1786 tons/h	1929 tons/h	1824 tons/h	1753 tons/h	1687 tons/h	
	66 sec	1.10 min	1864 tons/h	1771 tons/h	1707 tons/h	1648 tons/h	1760 tons/h	1673 tons/h	1613 tons/h	1557 tons/h	
80%	30 sec	0.50 min	2425 tons/h	2265 tons/h	2157 tons/h	2060 tons/h	2291 tons/h	2139 tons/h	2037 tons/h	1945 tons/h	
	42 sec	0.70 min	2169 tons/h	2039 tons/h	1952 tons/h	1872 tons/h	2048 tons/h	1926 tons/h	1843 tons/h	1768 tons/h	
	54 sec	0.90 min	1961 tons/h	1855 tons/h	1782 tons/h	1715 tons/h	1852 tons/h	1752 tons/h	1683 tons/h	1620 tons/h	
	66 sec	1.10 min	1790 tons/h	1701 tons/h	1640 tons/h	1583 tons/h	1690 tons/h	1606 tons/h	1548 tons/h	1495 tons/h	
75%	30 sec	0.50 min	2273 tons/h	2123 tons/h	2022 tons/h	1931 tons/h	2147 tons/h	2005 tons/h	1910 tons/h	1823 tons/h	
	42 sec	0.70 min	2033 tons/h	1911 tons/h	1829 tons/h	1754 tons/h	1920 tons/h	1805 tons/h	1728 tons/h	1657 tons/h	
	54 sec	0.90 min	1838 tons/h	1738 tons/h	1670 tons/h	1607 tons/h	1736 tons/h	1642 tons/h	1578 tons/h	1518 tons/h	
	66 sec	1.10 min	1678 tons/h	1594 tons/h	1537 tons/h	1483 tons/h	1584 tons/h	1506 tons/h	1451 tons/h	1401 tons/h	
70%	30 sec	0.50 min	2121 tons/h	1980 tons/h	1887 tons/h	1801 tons/h	2003 tons/h	1870 tons/h	1782 tons/h	1701 tons/h	
	42 sec	0.70 min	1897 tons/h	1783 tons/h	1707 tons/h	1637 tons/h	1791 tons/h	1684 tons/h	1612 tons/h	1546 tons/h	
	54 sec	0.90 min	1715 tons/h	1622 tons/h	1559 tons/h	1500 tons/h	1620 tons/h	1532 tons/h	1472 tons/h	1417 tons/h	
	66 sec	1.10 min	1565 tons/h	1487 tons/h	1434 tons/h	1384 tons/h	1478 tons/h	1405 tons/h	1354 tons/h	1307 tons/h	
65%	30 sec	0.50 min	1969 tons/h	1838 tons/h	1751 tons/h	1672 tons/h	1860 tons/h	1736 tons/h	1654 tons/h	1579 tons/h	
	42 sec	0.70 min	1761 tons/h	1655 tons/h	1585 tons/h	1519 tons/h	1663 tons/h	1563 tons/h	1496 tons/h	1435 tons/h	
	54 sec	0.90 min	1592 tons/h	1506 tons/h	1447 tons/h	1392 tons/h	1504 tons/h	1422 tons/h	1366 tons/h	1315 tons/h	
	66 sec	1.10 min	1453 tons/h	1381 tons/h	1331 tons/h	1285 tons/h	1372 tons/h	1304 tons/h	1257 tons/h	1213 tons/h	

MODEL: 6030 ● Bucket Size: 17.0 m<sup>3</sup> ● Number of Cycles: 5 ● Material Density: 1.80 t/m<sup>3</sup>

Overall Mine Efficiency	Bucket Fill Factor		100%				95%			
	Load per Bucket		30.6 t				29.1 t			
	Load per Truck		153 t				145 t			
Truck Exchange	Cycle Time		24 sec	26 sec	28 sec	30 sec	24 sec	26 sec	28 sec	30 sec
	0.40 min	0.43 min	0.47 min	0.50 min	0.40 min	0.43 min	0.47 min	0.50 min		
83% = maximum 50 min/hour	30 sec	0.50 min	3544 t/h	3357 t/h	3136 t/h	2988 t/h	3367 t/h	3189 t/h	2979 t/h	2839 t/h
	42 sec	0.70 min	3242 t/h	3085 t/h	2897 t/h	2771 t/h	3080 t/h	2931 t/h	2752 t/h	2632 t/h
	54 sec	0.90 min	2988 t/h	2854 t/h	2692 t/h	2583 t/h	2839 t/h	2711 t/h	2558 t/h	2454 t/h
	66 sec	1.10 min	2771 t/h	2655 t/h	2515 t/h	2419 t/h	2632 t/h	2522 t/h	2389 t/h	2298 t/h
80%	30 sec	0.50 min	3403 t/h	3223 t/h	3011 t/h	2869 t/h	3233 t/h	3062 t/h	2860 t/h	2726 t/h
	42 sec	0.70 min	3113 t/h	2962 t/h	2782 t/h	2661 t/h	2958 t/h	2814 t/h	2643 t/h	2528 t/h
	54 sec	0.90 min	2869 t/h	2740 t/h	2585 t/h	2480 t/h	2726 t/h	2603 t/h	2456 t/h	2356 t/h
	66 sec	1.10 min	2661 t/h	2549 t/h	2415 t/h	2323 t/h	2528 t/h	2422 t/h	2294 t/h	2207 t/h
75%	30 sec	0.50 min	3190 t/h	3021 t/h	2822 t/h	2689 t/h	3030 t/h	2870 t/h	2681 t/h	2555 t/h
	42 sec	0.70 min	2918 t/h	2776 t/h	2607 t/h	2494 t/h	2772 t/h	2637 t/h	2477 t/h	2369 t/h
	54 sec	0.90 min	2689 t/h	2568 t/h	2423 t/h	2325 t/h	2555 t/h	2440 t/h	2302 t/h	2208 t/h
	66 sec	1.10 min	2494 t/h	2389 t/h	2263 t/h	2177 t/h	2369 t/h	2270 t/h	2150 t/h	2068 t/h
70%	30 sec	0.50 min	2976 t/h	2819 t/h	2633 t/h	2509 t/h	2827 t/h	2678 t/h	2501 t/h	2384 t/h
	42 sec	0.70 min	2723 t/h	2590 t/h	2433 t/h	2327 t/h	2587 t/h	2461 t/h	2311 t/h	2210 t/h
	54 sec	0.90 min	2509 t/h	2396 t/h	2261 t/h	2169 t/h	2384 t/h	2277 t/h	2148 t/h	2061 t/h
	66 sec	1.10 min	2327 t/h	2229 t/h	2112 t/h	2031 t/h	2210 t/h	2118 t/h	2006 t/h	1930 t/h
65%	30 sec	0.50 min	2763 t/h	2617 t/h	2444 t/h	2329 t/h	2624 t/h	2486 t/h	2322 t/h	2213 t/h
	42 sec	0.70 min	2527 t/h	2405 t/h	2258 t/h	2160 t/h	2401 t/h	2284 t/h	2145 t/h	2052 t/h
	54 sec	0.90 min	2329 t/h	2225 t/h	2099 t/h	2013 t/h	2213 t/h	2113 t/h	1994 t/h	1913 t/h
	66 sec	1.10 min	2160 t/h	2069 t/h	1960 t/h	1886 t/h	2052 t/h	1966 t/h	1862 t/h	1791 t/h

Overall Mine Efficiency	Bucket Fill Factor		90%				85%			
	Load per Bucket		275 t				26.0 t			
	Load per Truck		138 t				130 t			
Truck Exchange	Cycle Time		24 sec	26 sec	28 sec	30 sec	24 sec	26 sec	28 sec	30 sec
	0.40 min	0.43 min	0.47 min	0.50 min	0.40 min	0.43 min	0.47 min	0.50 min		
83% = maximum 50 min/hour	30 sec	0.50 min	3190 t/h	3021 t/h	2822 t/h	2689 t/h	3012 t/h	2853 t/h	2665 t/h	2540 t/h
	42 sec	0.70 min	2918 t/h	2776 t/h	2607 t/h	2494 t/h	2756 t/h	2622 t/h	2463 t/h	2355 t/h
	54 sec	0.90 min	2689 t/h	2568 t/h	2423 t/h	2325 t/h	2540 t/h	2426 t/h	2289 t/h	2195 t/h
	66 sec	1.10 min	2494 t/h	2389 t/h	2263 t/h	2177 t/h	2355 t/h	2257 t/h	2137 t/h	2056 t/h
80%	30 sec	0.50 min	3063 t/h	2901 t/h	2710 t/h	2582 t/h	2893 t/h	2740 t/h	2559 t/h	2439 t/h
	42 sec	0.70 min	2802 t/h	2666 t/h	2504 t/h	2394 t/h	2646 t/h	2518 t/h	2365 t/h	2261 t/h
	54 sec	0.90 min	2582 t/h	2466 t/h	2327 t/h	2232 t/h	2439 t/h	2329 t/h	2198 t/h	2108 t/h
	66 sec	1.10 min	2394 t/h	2294 t/h	2173 t/h	2090 t/h	2261 t/h	2167 t/h	2052 t/h	1974 t/h
75%	30 sec	0.50 min	2871 t/h	2719 t/h	2540 t/h	2420 t/h	2711 t/h	2568 t/h	2399 t/h	2286 t/h
	42 sec	0.70 min	2626 t/h	2499 t/h	2347 t/h	2244 t/h	2480 t/h	2360 t/h	2216 t/h	2120 t/h
	54 sec	0.90 min	2420 t/h	2312 t/h	2181 t/h	2092 t/h	2286 t/h	2183 t/h	2060 t/h	1976 t/h
	66 sec	1.10 min	2244 t/h	2150 t/h	2037 t/h	1959 t/h	2120 t/h	2031 t/h	1924 t/h	1850 t/h
70%	30 sec	0.50 min	2678 t/h	2537 t/h	2370 t/h	2258 t/h	2530 t/h	2396 t/h	2238 t/h	2133 t/h
	42 sec	0.70 min	2450 t/h	2331 t/h	2190 t/h	2094 t/h	2314 t/h	2202 t/h	2068 t/h	1978 t/h
	54 sec	0.90 min	2258 t/h	2157 t/h	2035 t/h	1952 t/h	2133 t/h	2037 t/h	1922 t/h	1844 t/h
	66 sec	1.10 min	2094 t/h	2006 t/h	1901 t/h	1828 t/h	1978 t/h	1895 t/h	1795 t/h	1727 t/h
65%	30 sec	0.50 min	2486 t/h	2355 t/h	2200 t/h	2096 t/h	2348 t/h	2224 t/h	2078 t/h	1980 t/h
	42 sec	0.70 min	2275 t/h	2164 t/h	2033 t/h	1944 t/h	2148 t/h	2044 t/h	1920 t/h	1836 t/h
	54 sec	0.90 min	2096 t/h	2002 t/h	1889 t/h	1812 t/h	1980 t/h	1891 t/h	1784 t/h	1711 t/h
	66 sec	1.10 min	1944 t/h	1863 t/h	1764 t/h	1697 t/h	1836 t/h	1759 t/h	1666 t/h	1603 t/h



**MODEL: 6030 ● Bucket Size: 22.2 yd<sup>3</sup> ● Number of Cycles: 5 ● Material Density: 3030 lb/yd<sup>3</sup>**

Overall Mine Efficiency	Bucket Fill Factor		100%				95%			
	Load per Bucket		33.7 tons				32.1 tons			
	Load per Truck		169 tons				160 tons			
Truck Exchange	Cycle Time		24 sec	26 sec	28 sec	30 sec	24 sec	26 sec	28 sec	30 sec
	0.40 min	0.50 min	0.43 min	0.47 min	0.50 min	0.40 min	0.43 min	0.47 min	0.50 min	
83% = maximum 50 min/hour	30 sec	0.50 min	3906 tons/h	3700 tons/h	3456 tons/h	3294 tons/h	3715 tons/h	3519 tons/h	3287 tons/h	3132 tons/h
	42 sec	0.70 min	3574 tons/h	3400 tons/h	3194 tons/h	3054 tons/h	3399 tons/h	3234 tons/h	3037 tons/h	2904 tons/h
	54 sec	0.90 min	3294 tons/h	3146 tons/h	2968 tons/h	2847 tons/h	3132 tons/h	2991 tons/h	2822 tons/h	2708 tons/h
	66 sec	1.10 min	3054 tons/h	2926 tons/h	2772 tons/h	2666 tons/h	2904 tons/h	2783 tons/h	2636 tons/h	2536 tons/h
80%	30 sec	0.50 min	3751 tons/h	3553 tons/h	3319 tons/h	3163 tons/h	3567 tons/h	3379 tons/h	3156 tons/h	3008 tons/h
	42 sec	0.70 min	3432 tons/h	3265 tons/h	3067 tons/h	2933 tons/h	3264 tons/h	3105 tons/h	2916 tons/h	2789 tons/h
	54 sec	0.90 min	3163 tons/h	3021 tons/h	2850 tons/h	2734 tons/h	3008 tons/h	2873 tons/h	2710 tons/h	2600 tons/h
	66 sec	1.10 min	2933 tons/h	2810 tons/h	2662 tons/h	2560 tons/h	2789 tons/h	2672 tons/h	2531 tons/h	2435 tons/h
75%	30 sec	0.50 min	3516 tons/h	3330 tons/h	3111 tons/h	2964 tons/h	3343 tons/h	3167 tons/h	2958 tons/h	2819 tons/h
	42 sec	0.70 min	3217 tons/h	3060 tons/h	2874 tons/h	2749 tons/h	3059 tons/h	2910 tons/h	2733 tons/h	2614 tons/h
	54 sec	0.90 min	2964 tons/h	2831 tons/h	2671 tons/h	2562 tons/h	2819 tons/h	2692 tons/h	2540 tons/h	2437 tons/h
	66 sec	1.10 min	2749 tons/h	2634 tons/h	2495 tons/h	2400 tons/h	2614 tons/h	2505 tons/h	2372 tons/h	2282 tons/h
70%	30 sec	0.50 min	3281 tons/h	3107 tons/h	2903 tons/h	2766 tons/h	3120 tons/h	2955 tons/h	2760 tons/h	2630 tons/h
	42 sec	0.70 min	3001 tons/h	2856 tons/h	2682 tons/h	2565 tons/h	2854 tons/h	2716 tons/h	2550 tons/h	2439 tons/h
	54 sec	0.90 min	2766 tons/h	2642 tons/h	2492 tons/h	2391 tons/h	2630 tons/h	2512 tons/h	2370 tons/h	2274 tons/h
	66 sec	1.10 min	2565 tons/h	2458 tons/h	2328 tons/h	2239 tons/h	2439 tons/h	2337 tons/h	2214 tons/h	2129 tons/h
65%	30 sec	0.50 min	3045 tons/h	2884 tons/h	2694 tons/h	2568 tons/h	2896 tons/h	2743 tons/h	2562 tons/h	2432 tons/h
	42 sec	0.70 min	2786 tons/h	2651 tons/h	2489 tons/h	2381 tons/h	2649 tons/h	2521 tons/h	2367 tons/h	2264 tons/h
	54 sec	0.90 min	2568 tons/h	2452 tons/h	2313 tons/h	2219 tons/h	2442 tons/h	2332 tons/h	2200 tons/h	2111 tons/h
	66 sec	1.10 min	2381 tons/h	2281 tons/h	2161 tons/h	2078 tons/h	2264 tons/h	2169 tons/h	2055 tons/h	1977 tons/h

Overall Mine Efficiency	Bucket Fill Factor		90%				85%			
	Load per Bucket		30.3 tons				28.7 tons			
	Load per Truck		152 tons				143 tons			
Truck Exchange	Cycle Time		24 sec	26 sec	28 sec	30 sec	24 sec	26 sec	28 sec	30 sec
	0.40 min	0.50 min	0.43 min	0.47 min	0.50 min	0.40 min	0.43 min	0.47 min	0.50 min	
83% = maximum 50 min/hour	30 sec	0.50 min	3511 tons/h	3325 tons/h	3106 tons/h	2960 tons/h	3319 tons/h	3144 tons/h	2937 tons/h	2799 tons/h
	42 sec	0.70 min	3212 tons/h	3056 tons/h	2870 tons/h	2745 tons/h	3037 tons/h	2889 tons/h	2713 tons/h	2595 tons/h
	54 sec	0.90 min	2960 tons/h	2827 tons/h	2667 tons/h	2559 tons/h	2799 tons/h	2673 tons/h	2522 tons/h	2419 tons/h
	66 sec	1.10 min	2745 tons/h	2630 tons/h	2491 tons/h	2396 tons/h	2595 tons/h	2487 tons/h	2355 tons/h	2266 tons/h
80%	30 sec	0.50 min	3371 tons/h	3193 tons/h	2983 tons/h	2842 tons/h	3187 tons/h	3019 tons/h	2820 tons/h	2687 tons/h
	42 sec	0.70 min	3084 tons/h	2934 tons/h	2756 tons/h	2636 tons/h	2916 tons/h	2774 tons/h	2606 tons/h	2492 tons/h
	54 sec	0.90 min	2842 tons/h	2715 tons/h	2561 tons/h	2457 tons/h	2687 tons/h	2567 tons/h	2421 tons/h	2323 tons/h
	66 sec	1.10 min	2636 tons/h	2525 tons/h	2392 tons/h	2301 tons/h	2492 tons/h	2388 tons/h	2262 tons/h	2175 tons/h
75%	30 sec	0.50 min	3160 tons/h	2993 tons/h	2796 tons/h	2664 tons/h	2987 tons/h	2829 tons/h	2643 tons/h	2519 tons/h
	42 sec	0.70 min	2891 tons/h	2750 tons/h	2583 tons/h	2470 tons/h	2733 tons/h	2600 tons/h	2442 tons/h	2336 tons/h
	54 sec	0.90 min	2664 tons/h	2544 tons/h	2400 tons/h	2303 tons/h	2519 tons/h	2406 tons/h	2270 tons/h	2177 tons/h
	66 sec	1.10 min	2470 tons/h	2367 tons/h	2242 tons/h	2157 tons/h	2336 tons/h	2238 tons/h	2120 tons/h	2039 tons/h
70%	30 sec	0.50 min	2948 tons/h	2792 tons/h	2608 tons/h	2486 tons/h	2787 tons/h	2640 tons/h	2466 tons/h	2350 tons/h
	42 sec	0.70 min	2697 tons/h	2566 tons/h	2410 tons/h	2305 tons/h	2550 tons/h	2426 tons/h	2279 tons/h	2179 tons/h
	54 sec	0.90 min	2486 tons/h	2374 tons/h	2240 tons/h	2149 tons/h	2350 tons/h	2245 tons/h	2118 tons/h	2031 tons/h
	66 sec	1.10 min	2305 tons/h	2209 tons/h	2092 tons/h	2012 tons/h	2179 tons/h	2088 tons/h	1978 tons/h	1902 tons/h
65%	30 sec	0.50 min	2737 tons/h	2592 tons/h	2421 tons/h	2307 tons/h	2587 tons/h	2451 tons/h	2289 tons/h	2182 tons/h
	42 sec	0.70 min	2504 tons/h	2382 tons/h	2237 tons/h	2140 tons/h	2367 tons/h	2252 tons/h	2115 tons/h	2023 tons/h
	54 sec	0.90 min	2307 tons/h	2204 tons/h	2079 tons/h	1995 tons/h	2182 tons/h	2083 tons/h	1966 tons/h	1886 tons/h
	66 sec	1.10 min	2140 tons/h	2050 tons/h	1942 tons/h	1868 tons/h	2023 tons/h	1938 tons/h	1836 tons/h	1766 tons/h

MODEL: 6030 FS ● Bucket Size: 16.5 m<sup>3</sup> ● Number of Cycles: 5 ● Material Density: 1.80 t/m<sup>3</sup>

Overall Mine Efficiency	Bucket Fill Factor		100%				95%			
	Load per Bucket		29.7 t				28.2 t			
	Load per Truck		149 t				141 t			
Truck Exchange	Cycle Time		24 sec	26 sec	28 sec	30 sec	24 sec	26 sec	28 sec	30 sec
	0.40 min	0.43 min	0.47 min	0.50 min	0.40 min	0.43 min	0.47 min	0.50 min		
83% = maximum 50 min/hour	30 sec	0.50 min	3440 t/h	3258 t/h	3043 t/h	2900 t/h	3266 t/h	3093 t/h	2890 t/h	2754 t/h
	42 sec	0.70 min	3147 t/h	2994 t/h	2812 t/h	2689 t/h	2988 t/h	2843 t/h	2670 t/h	2553 t/h
	54 sec	0.90 min	2900 t/h	2770 t/h	2613 t/h	2507 t/h	2754 t/h	2630 t/h	2481 t/h	2380 t/h
	66 sec	1.10 min	2689 t/h	2577 t/h	2441 t/h	2348 t/h	2553 t/h	2447 t/h	2317 t/h	2229 t/h
80%	30 sec	0.50 min	3303 t/h	3128 t/h	2922 t/h	2785 t/h	3136 t/h	2970 t/h	2775 t/h	2644 t/h
	42 sec	0.70 min	3022 t/h	2875 t/h	2700 t/h	2582 t/h	2869 t/h	2730 t/h	2564 t/h	2452 t/h
	54 sec	0.90 min	2785 t/h	2660 t/h	2509 t/h	2407 t/h	2644 t/h	2525 t/h	2383 t/h	2286 t/h
	66 sec	1.10 min	2582 t/h	2474 t/h	2344 t/h	2254 t/h	2452 t/h	2349 t/h	2225 t/h	2141 t/h
75%	30 sec	0.50 min	3096 t/h	2932 t/h	2739 t/h	2610 t/h	2939 t/h	2784 t/h	2601 t/h	2478 t/h
	42 sec	0.70 min	2832 t/h	2695 t/h	2531 t/h	2420 t/h	2689 t/h	2559 t/h	2403 t/h	2298 t/h
	54 sec	0.90 min	2610 t/h	2493 t/h	2352 t/h	2256 t/h	2478 t/h	2367 t/h	2233 t/h	2142 t/h
	66 sec	1.10 min	2420 t/h	2319 t/h	2197 t/h	2113 t/h	2298 t/h	2202 t/h	2086 t/h	2006 t/h
70%	30 sec	0.50 min	2888 t/h	2736 t/h	2556 t/h	2435 t/h	2743 t/h	2598 t/h	2427 t/h	2312 t/h
	42 sec	0.70 min	2643 t/h	2514 t/h	2361 t/h	2258 t/h	2509 t/h	2387 t/h	2242 t/h	2144 t/h
	54 sec	0.90 min	2435 t/h	2326 t/h	2194 t/h	2105 t/h	2312 t/h	2208 t/h	2084 t/h	1999 t/h
	66 sec	1.10 min	2258 t/h	2164 t/h	2050 t/h	1972 t/h	2144 t/h	2055 t/h	1946 t/h	1872 t/h
65%	30 sec	0.50 min	2681 t/h	2540 t/h	2372 t/h	2261 t/h	2546 t/h	2411 t/h	2253 t/h	2147 t/h
	42 sec	0.70 min	2453 t/h	2334 t/h	2192 t/h	2096 t/h	2329 t/h	2216 t/h	2081 t/h	1990 t/h
	54 sec	0.90 min	2261 t/h	2159 t/h	2037 t/h	1954 t/h	2147 t/h	2050 t/h	1934 t/h	1855 t/h
	66 sec	1.10 min	2096 t/h	2009 t/h	1903 t/h	1830 t/h	1990 t/h	1907 t/h	1806 t/h	1738 t/h

Overall Mine Efficiency	Bucket Fill Factor		90%				85%			
	Load per Bucket		26.7 t				25.2 t			
	Load per Truck		134 t				126 t			
Truck Exchange	Cycle Time		24 sec	26 sec	28 sec	30 sec	24 sec	26 sec	28 sec	30 sec
	0.40 min	0.43 min	0.47 min	0.50 min	0.40 min	0.43 min	0.47 min	0.50 min		
83% = maximum 50 min/hour	30 sec	0.50 min	3092 t/h	2929 t/h	2736 t/h	2607 t/h	2919 t/h	2764 t/h	2582 t/h	2461 t/h
	42 sec	0.70 min	2829 t/h	2692 t/h	2528 t/h	2418 t/h	2670 t/h	2540 t/h	2386 t/h	2282 t/h
	54 sec	0.90 min	2607 t/h	2490 t/h	2349 t/h	2254 t/h	2461 t/h	2350 t/h	2217 t/h	2127 t/h
	66 sec	1.10 min	2418 t/h	2316 t/h	2194 t/h	2111 t/h	2282 t/h	2186 t/h	2071 t/h	1992 t/h
80%	30 sec	0.50 min	2969 t/h	2812 t/h	2627 t/h	2504 t/h	2802 t/h	2654 t/h	2480 t/h	2363 t/h
	42 sec	0.70 min	2717 t/h	2585 t/h	2427 t/h	2321 t/h	2564 t/h	2439 t/h	2291 t/h	2191 t/h
	54 sec	0.90 min	2504 t/h	2391 t/h	2256 t/h	2164 t/h	2363 t/h	2257 t/h	2129 t/h	2042 t/h
	66 sec	1.10 min	2321 t/h	2224 t/h	2107 t/h	2027 t/h	2191 t/h	2099 t/h	1989 t/h	1913 t/h
75%	30 sec	0.50 min	2783 t/h	2636 t/h	2462 t/h	2346 t/h	2627 t/h	2488 t/h	2324 t/h	2215 t/h
	42 sec	0.70 min	2546 t/h	2422 t/h	2275 t/h	2176 t/h	2403 t/h	2286 t/h	2147 t/h	2054 t/h
	54 sec	0.90 min	2346 t/h	2241 t/h	2114 t/h	2028 t/h	2215 t/h	2115 t/h	1996 t/h	1914 t/h
	66 sec	1.10 min	2176 t/h	2085 t/h	1975 t/h	1900 t/h	2054 t/h	1968 t/h	1864 t/h	1793 t/h
70%	30 sec	0.50 min	2597 t/h	2459 t/h	2298 t/h	2189 t/h	2451 t/h	2321 t/h	2168 t/h	2066 t/h
	42 sec	0.70 min	2376 t/h	2260 t/h	2123 t/h	2030 t/h	2242 t/h	2133 t/h	2004 t/h	1916 t/h
	54 sec	0.90 min	2189 t/h	2091 t/h	1973 t/h	1893 t/h	2066 t/h	1974 t/h	1862 t/h	1786 t/h
	66 sec	1.10 min	2030 t/h	1945 t/h	1843 t/h	1772 t/h	1916 t/h	1836 t/h	1739 t/h	1673 t/h
65%	30 sec	0.50 min	2410 t/h	2283 t/h	2133 t/h	2032 t/h	2275 t/h	2155 t/h	2013 t/h	1918 t/h
	42 sec	0.70 min	2205 t/h	2098 t/h	1971 t/h	1885 t/h	2081 t/h	1980 t/h	1860 t/h	1779 t/h
	54 sec	0.90 min	2032 t/h	1941 t/h	1831 t/h	1757 t/h	1918 t/h	1832 t/h	1728 t/h	1658 t/h
	66 sec	1.10 min	1885 t/h	1806 t/h	1710 t/h	1645 t/h	1779 t/h	1704 t/h	1614 t/h	1553 t/h

**MODEL: 6030 FS ● Bucket Size: 21.6 yd<sup>3</sup> ● Number of Cycles: 5 ● Material Density: 3030 lb/yd<sup>3</sup>**

Overall Mine Efficiency	Bucket Fill Factor		100%				95%			
	Load per Bucket		32.7 tons				31.1 tons			
	Load per Truck		164 tons				155 tons			
Truck Exchange	Cycle Time		24 sec	26 sec	28 sec	30 sec	24 sec	26 sec	28 sec	30 sec
	0.40 min	0.50 min	0.43 min	0.47 min	0.50 min	0.40 min	0.43 min	0.47 min	0.50 min	
83% = maximum 50 min/hour	30 sec	0.50 min	3792 tons/h	3591 tons/h	3355 tons/h	3197 tons/h	3600 tons/h	3410 tons/h	3185 tons/h	3035 tons/h
	42 sec	0.70 min	3469 tons/h	3300 tons/h	3100 tons/h	2964 tons/h	3294 tons/h	3134 tons/h	2943 tons/h	2815 tons/h
	54 sec	0.90 min	3197 tons/h	3053 tons/h	2881 tons/h	2763 tons/h	3035 tons/h	2899 tons/h	2735 tons/h	2624 tons/h
	66 sec	1.10 min	2964 tons/h	2840 tons/h	2690 tons/h	2588 tons/h	2815 tons/h	2697 tons/h	2555 tons/h	2457 tons/h
80%	30 sec	0.50 min	3641 tons/h	3448 tons/h	3221 tons/h	3070 tons/h	3457 tons/h	3274 tons/h	3059 tons/h	2915 tons/h
	42 sec	0.70 min	3331 tons/h	3169 tons/h	2976 tons/h	2846 tons/h	3163 tons/h	3009 tons/h	2826 tons/h	2703 tons/h
	54 sec	0.90 min	3070 tons/h	2932 tons/h	2766 tons/h	2653 tons/h	2915 tons/h	2784 tons/h	2626 tons/h	2519 tons/h
	66 sec	1.10 min	2846 tons/h	2727 tons/h	2583 tons/h	2485 tons/h	2703 tons/h	2590 tons/h	2453 tons/h	2360 tons/h
75%	30 sec	0.50 min	3412 tons/h	3232 tons/h	3019 tons/h	2877 tons/h	3240 tons/h	3069 tons/h	2867 tons/h	2732 tons/h
	42 sec	0.70 min	3122 tons/h	2970 tons/h	2790 tons/h	2668 tons/h	2964 tons/h	2820 tons/h	2649 tons/h	2533 tons/h
	54 sec	0.90 min	2877 tons/h	2748 tons/h	2592 tons/h	2487 tons/h	2732 tons/h	2609 tons/h	2462 tons/h	2361 tons/h
	66 sec	1.10 min	2668 tons/h	2556 tons/h	2421 tons/h	2329 tons/h	2533 tons/h	2427 tons/h	2299 tons/h	2211 tons/h
70%	30 sec	0.50 min	3184 tons/h	3016 tons/h	2817 tons/h	2685 tons/h	3023 tons/h	2863 tons/h	2675 tons/h	2549 tons/h
	42 sec	0.70 min	2913 tons/h	2772 tons/h	2603 tons/h	2489 tons/h	2766 tons/h	2632 tons/h	2471 tons/h	2364 tons/h
	54 sec	0.90 min	2685 tons/h	2564 tons/h	2419 tons/h	2321 tons/h	2549 tons/h	2434 tons/h	2297 tons/h	2203 tons/h
	66 sec	1.10 min	2489 tons/h	2385 tons/h	2259 tons/h	2173 tons/h	2364 tons/h	2265 tons/h	2145 tons/h	2063 tons/h
65%	30 sec	0.50 min	2956 tons/h	2799 tons/h	2615 tons/h	2492 tons/h	2806 tons/h	2658 tons/h	2483 tons/h	2366 tons/h
	42 sec	0.70 min	2704 tons/h	2573 tons/h	2416 tons/h	2311 tons/h	2568 tons/h	2443 tons/h	2294 tons/h	2194 tons/h
	54 sec	0.90 min	2492 tons/h	2380 tons/h	2245 tons/h	2154 tons/h	2366 tons/h	2260 tons/h	2132 tons/h	2045 tons/h
	66 sec	1.10 min	2311 tons/h	2214 tons/h	2097 tons/h	2017 tons/h	2194 tons/h	2102 tons/h	1991 tons/h	1915 tons/h

Overall Mine Efficiency	Bucket Fill Factor		90%				85%			
	Load per Bucket		29.4 tons				27.8 tons			
	Load per Truck		147 tons				139 tons			
Truck Exchange	Cycle Time		24 sec	26 sec	28 sec	30 sec	24 sec	26 sec	28 sec	30 sec
	0.40 min	0.50 min	0.43 min	0.47 min	0.50 min	0.40 min	0.43 min	0.47 min	0.50 min	
83% = maximum 50 min/hour	30 sec	0.50 min	3409 tons/h	3228 tons/h	3016 tons/h	2874 tons/h	3217 tons/h	3047 tons/h	2846 tons/h	2712 tons/h
	42 sec	0.70 min	3119 tons/h	2967 tons/h	2786 tons/h	2665 tons/h	2943 tons/h	2800 tons/h	2630 tons/h	2515 tons/h
	54 sec	0.90 min	2874 tons/h	2745 tons/h	2590 tons/h	2484 tons/h	2712 tons/h	2591 tons/h	2444 tons/h	2345 tons/h
	66 sec	1.10 min	2665 tons/h	2553 tons/h	2419 tons/h	2327 tons/h	2515 tons/h	2410 tons/h	2283 tons/h	2196 tons/h
80%	30 sec	0.50 min	3273 tons/h	3100 tons/h	2896 tons/h	2760 tons/h	3089 tons/h	2926 tons/h	2733 tons/h	2605 tons/h
	42 sec	0.70 min	2995 tons/h	2849 tons/h	2676 tons/h	2559 tons/h	2826 tons/h	2689 tons/h	2525 tons/h	2415 tons/h
	54 sec	0.90 min	2760 tons/h	2636 tons/h	2487 tons/h	2385 tons/h	2605 tons/h	2488 tons/h	2347 tons/h	2251 tons/h
	66 sec	1.10 min	2559 tons/h	2452 tons/h	2322 tons/h	2234 tons/h	2415 tons/h	2314 tons/h	2192 tons/h	2109 tons/h
75%	30 sec	0.50 min	3068 tons/h	2906 tons/h	2714 tons/h	2587 tons/h	2895 tons/h	2742 tons/h	2562 tons/h	2441 tons/h
	42 sec	0.70 min	2807 tons/h	2670 tons/h	2508 tons/h	2398 tons/h	2649 tons/h	2520 tons/h	2367 tons/h	2264 tons/h
	54 sec	0.90 min	2587 tons/h	2470 tons/h	2331 tons/h	2236 tons/h	2441 tons/h	2331 tons/h	2200 tons/h	2110 tons/h
	66 sec	1.10 min	2398 tons/h	2298 tons/h	2177 tons/h	2094 tons/h	2264 tons/h	2169 tons/h	2054 tons/h	1976 tons/h
70%	30 sec	0.50 min	2862 tons/h	2711 tons/h	2533 tons/h	2413 tons/h	2702 tons/h	2559 tons/h	2390 tons/h	2278 tons/h
	42 sec	0.70 min	2619 tons/h	2492 tons/h	2340 tons/h	2238 tons/h	2472 tons/h	2352 tons/h	2209 tons/h	2112 tons/h
	54 sec	0.90 min	2413 tons/h	2305 tons/h	2175 tons/h	2086 tons/h	2278 tons/h	2175 tons/h	2052 tons/h	1969 tons/h
	66 sec	1.10 min	2238 tons/h	2144 tons/h	2031 tons/h	1954 tons/h	2112 tons/h	2024 tons/h	1917 tons/h	1844 tons/h
65%	30 sec	0.50 min	2657 tons/h	2517 tons/h	2351 tons/h	2240 tons/h	2508 tons/h	2375 tons/h	2219 tons/h	2114 tons/h
	42 sec	0.70 min	2431 tons/h	2313 tons/h	2172 tons/h	2077 tons/h	2294 tons/h	2183 tons/h	2050 tons/h	1961 tons/h
	54 sec	0.90 min	2240 tons/h	2140 tons/h	2019 tons/h	1937 tons/h	2114 tons/h	2019 tons/h	1905 tons/h	1828 tons/h
	66 sec	1.10 min	2077 tons/h	1990 tons/h	1885 tons/h	1814 tons/h	1961 tons/h	1879 tons/h	1779 tons/h	1712 tons/h

MODEL: 6040 and 6040 FS ● Bucket Size: 22.0 m<sup>3</sup> ● Number of Cycles: 4  
● Material Density: 1.80 t/m<sup>3</sup>

		Bucket Fill Factor		100%				95%			
		Load per Bucket		39.6 t				37.6 t			
		Load per Truck		158 t				150 t			
Overall Mine Efficiency	Cycle Time		24 sec	26 sec	28 sec	30 sec	24 sec	26 sec	28 sec	30 sec	
	Truck Exchange		0.40 min	0.43 min	0.47 min	0.50 min	0.40 min	0.43 min	0.47 min	0.50 min	
83% = maximum 50 min/hour	30 sec	0.50 min	4508 t/h	4287 t/h	4025 t/h	3848 t/h	4280 t/h	4071 t/h	3821 t/h	3654 t/h	
	42 sec	0.70 min	4045 t/h	3867 t/h	3652 t/h	3506 t/h	3841 t/h	3672 t/h	3468 t/h	3329 t/h	
	54 sec	0.90 min	3669 t/h	3522 t/h	3343 t/h	3220 t/h	3484 t/h	3344 t/h	3174 t/h	3057 t/h	
	66 sec	1.10 min	3357 t/h	3233 t/h	3081 t/h	2977 t/h	3187 t/h	3070 t/h	2926 t/h	2826 t/h	
80%	30 sec	0.50 min	4328 t/h	4117 t/h	3865 t/h	3695 t/h	4110 t/h	3909 t/h	3669 t/h	3508 t/h	
	42 sec	0.70 min	3884 t/h	3713 t/h	3507 t/h	3367 t/h	3688 t/h	3526 t/h	3330 t/h	3197 t/h	
	54 sec	0.90 min	3523 t/h	3382 t/h	3210 t/h	3092 t/h	3345 t/h	3211 t/h	3048 t/h	2936 t/h	
	66 sec	1.10 min	3223 t/h	3104 t/h	2959 t/h	2858 t/h	3060 t/h	2948 t/h	2809 t/h	2714 t/h	
75%	30 sec	0.50 min	4057 t/h	3858 t/h	3622 t/h	3463 t/h	3852 t/h	3694 t/h	3439 t/h	3288 t/h	
	42 sec	0.70 min	3641 t/h	3480 t/h	3287 t/h	3155 t/h	3457 t/h	3304 t/h	3121 t/h	2996 t/h	
	54 sec	0.90 min	3302 t/h	3169 t/h	3008 t/h	2898 t/h	3135 t/h	3009 t/h	2856 t/h	2751 t/h	
	66 sec	1.10 min	3021 t/h	2910 t/h	2773 t/h	2679 t/h	2868 t/h	2763 t/h	2633 t/h	2544 t/h	
70%	30 sec	0.50 min	3785 t/h	3600 t/h	3380 t/h	3231 t/h	3594 t/h	3418 t/h	3209 t/h	3068 t/h	
	42 sec	0.70 min	3397 t/h	3247 t/h	3067 t/h	2944 t/h	3226 t/h	3083 t/h	2912 t/h	2795 t/h	
	54 sec	0.90 min	3081 t/h	2957 t/h	2807 t/h	2704 t/h	2925 t/h	2808 t/h	2665 t/h	2567 t/h	
	66 sec	1.10 min	2819 t/h	2715 t/h	2588 t/h	2500 t/h	2676 t/h	2578 t/h	2457 t/h	2373 t/h	
65%	30 sec	0.50 min	3514 t/h	3342 t/h	3137 t/h	3000 t/h	3336 t/h	3173 t/h	2979 t/h	2848 t/h	
	42 sec	0.70 min	3153 t/h	3014 t/h	2847 t/h	2733 t/h	2994 t/h	2862 t/h	2703 t/h	2595 t/h	
	54 sec	0.90 min	2860 t/h	2745 t/h	2606 t/h	2510 t/h	2716 t/h	2606 t/h	2474 t/h	2383 t/h	
	66 sec	1.10 min	2617 t/h	2520 t/h	2402 t/h	2320 t/h	2484 t/h	2393 t/h	2281 t/h	2203 t/h	

		Bucket Fill Factor		90%				85%			
		Load per Bucket		35.6 t				33.7 t			
		Load per Truck		142 t				135 t			
Overall Mine Efficiency	Cycle Time		24 sec	26 sec	28 sec	30 sec	24 sec	26 sec	28 sec	30 sec	
	Truck Exchange		0.40 min	0.43 min	0.47 min	0.50 min	0.40 min	0.43 min	0.47 min	0.50 min	
83% = maximum 50 min/hour	30 sec	0.50 min	4052 t/h	3854 t/h	3618 t/h	3459 t/h	3836 t/h	3648 t/h	3425 t/h	3275 t/h	
	42 sec	0.70 min	3637 t/h	3476 t/h	3283 t/h	3152 t/h	3443 t/h	3291 t/h	3108 t/h	2984 t/h	
	54 sec	0.90 min	3298 t/h	3166 t/h	3005 t/h	2894 t/h	3122 t/h	2997 t/h	2845 t/h	2740 t/h	
	66 sec	1.10 min	3018 t/h	2906 t/h	2770 t/h	2676 t/h	2857 t/h	2751 t/h	2622 t/h	2533 t/h	
80%	30 sec	0.50 min	3891 t/h	3701 t/h	3474 t/h	3322 t/h	3684 t/h	3503 t/h	3289 t/h	3144 t/h	
	42 sec	0.70 min	3492 t/h	3338 t/h	3153 t/h	3026 t/h	3306 t/h	3160 t/h	2984 t/h	2865 t/h	
	54 sec	0.90 min	3167 t/h	3040 t/h	2885 t/h	2779 t/h	2998 t/h	2878 t/h	2731 t/h	2631 t/h	
	66 sec	1.10 min	2898 t/h	2791 t/h	2660 t/h	2570 t/h	2743 t/h	2642 t/h	2518 t/h	2433 t/h	
75%	30 sec	0.50 min	3647 t/h	3469 t/h	3256 t/h	3113 t/h	3452 t/h	3284 t/h	3083 t/h	2947 t/h	
	42 sec	0.70 min	3273 t/h	3129 t/h	2955 t/h	2837 t/h	3098 t/h	2962 t/h	2797 t/h	2685 t/h	
	54 sec	0.90 min	2969 t/h	2849 t/h	2704 t/h	2605 t/h	2810 t/h	2697 t/h	2560 t/h	2466 t/h	
	66 sec	1.10 min	2716 t/h	2616 t/h	2493 t/h	2408 t/h	2571 t/h	2476 t/h	2360 t/h	2280 t/h	
70%	30 sec	0.50 min	3403 t/h	3237 t/h	3038 t/h	2905 t/h	3221 t/h	3064 t/h	2876 t/h	2750 t/h	
	42 sec	0.70 min	3054 t/h	2919 t/h	2757 t/h	2647 t/h	2891 t/h	2763 t/h	2610 t/h	2505 t/h	
	54 sec	0.90 min	2770 t/h	2659 t/h	2523 t/h	2431 t/h	2622 t/h	2517 t/h	2389 t/h	2301 t/h	
	66 sec	1.10 min	2534 t/h	2441 t/h	2326 t/h	2247 t/h	2399 t/h	2310 t/h	2202 t/h	2127 t/h	
65%	30 sec	0.50 min	3159 t/h	3004 t/h	2820 t/h	2697 t/h	2990 t/h	2844 t/h	2670 t/h	2553 t/h	
	42 sec	0.70 min	2835 t/h	2710 t/h	2559 t/h	2457 t/h	2684 t/h	2565 t/h	2423 t/h	2326 t/h	
	54 sec	0.90 min	2571 t/h	2468 t/h	2342 t/h	2256 t/h	2434 t/h	2336 t/h	2217 t/h	2136 t/h	
	66 sec	1.10 min	2352 t/h	2266 t/h	2159 t/h	2086 t/h	2227 t/h	2145 t/h	2044 t/h	1975 t/h	

MODEL: 6040 and 6040 FS ● Bucket Size: 28.8 yd<sup>3</sup> ● Number of Cycles: 4

● Material Density: 3030 lb/yd<sup>3</sup>

			100%				95%			
			43.7 tons				41.4 tons			
			175 tons				166 tons			
Overall Mine Efficiency	Cycle Time		24 sec	26 sec	28 sec	30 sec	24 sec	26 sec	28 sec	30 sec
	Truck Exchange		0.40 min	0.43 min	0.47 min	0.50 min	0.40 min	0.43 min	0.47 min	0.50 min
83% = maximum 50 min/hour	30 sec	0.50 min	4969 tons/h	4726 tons/h	4436 tons/h	4242 tons/h	4718 tons/h	4487 tons/h	4212 tons/h	4027 tons/h
	42 sec	0.70 min	4459 tons/h	4262 tons/h	4026 tons/h	3865 tons/h	4234 tons/h	4047 tons/h	3822 tons/h	3669 tons/h
	54 sec	0.90 min	4044 tons/h	3882 tons/h	3684 tons/h	3549 tons/h	3840 tons/h	3686 tons/h	3498 tons/h	3370 tons/h
	66 sec	1.10 min	3700 tons/h	3564 tons/h	3397 tons/h	3281 tons/h	3513 tons/h	3384 tons/h	3225 tons/h	3116 tons/h
80%	30 sec	0.50 min	4771 tons/h	4538 tons/h	4260 tons/h	4073 tons/h	4530 tons/h	4309 tons/h	4045 tons/h	3867 tons/h
	42 sec	0.70 min	4282 tons/h	4093 tons/h	3866 tons/h	3711 tons/h	4066 tons/h	3886 tons/h	3670 tons/h	3524 tons/h
	54 sec	0.90 min	3884 tons/h	3728 tons/h	3538 tons/h	3408 tons/h	3687 tons/h	3539 tons/h	3359 tons/h	3236 tons/h
	66 sec	1.10 min	3553 tons/h	3422 tons/h	3262 tons/h	3151 tons/h	3374 tons/h	3249 tons/h	3097 tons/h	2992 tons/h
75%	30 sec	0.50 min	4472 tons/h	4253 tons/h	3993 tons/h	3817 tons/h	4246 tons/h	4038 tons/h	3791 tons/h	3625 tons/h
	42 sec	0.70 min	4013 tons/h	3836 tons/h	3623 tons/h	3478 tons/h	3811 tons/h	3642 tons/h	3440 tons/h	3302 tons/h
	54 sec	0.90 min	3640 tons/h	3494 tons/h	3316 tons/h	3194 tons/h	3456 tons/h	3317 tons/h	3149 tons/h	3033 tons/h
	66 sec	1.10 min	3330 tons/h	3207 tons/h	3057 tons/h	2953 tons/h	3162 tons/h	3045 tons/h	2903 tons/h	2804 tons/h
70%	30 sec	0.50 min	4173 tons/h	3968 tons/h	3726 tons/h	3562 tons/h	3962 tons/h	3768 tons/h	3537 tons/h	3382 tons/h
	42 sec	0.70 min	3745 tons/h	3579 tons/h	3381 tons/h	3245 tons/h	3556 tons/h	3399 tons/h	3210 tons/h	3081 tons/h
	54 sec	0.90 min	3396 tons/h	3260 tons/h	3094 tons/h	2980 tons/h	3225 tons/h	3095 tons/h	2938 tons/h	2830 tons/h
	66 sec	1.10 min	3107 tons/h	2993 tons/h	2852 tons/h	2755 tons/h	2950 tons/h	2841 tons/h	2708 tons/h	2616 tons/h
65%	30 sec	0.50 min	3873 tons/h	3684 tons/h	3458 tons/h	3306 tons/h	3678 tons/h	3498 tons/h	3284 tons/h	3139 tons/h
	42 sec	0.70 min	3476 tons/h	3323 tons/h	3138 tons/h	3013 tons/h	3300 tons/h	3155 tons/h	2980 tons/h	2860 tons/h
	54 sec	0.90 min	3153 tons/h	3026 tons/h	2872 tons/h	2767 tons/h	2993 tons/h	2873 tons/h	2727 tons/h	2627 tons/h
	66 sec	1.10 min	2884 tons/h	2778 tons/h	2648 tons/h	2558 tons/h	2739 tons/h	2638 tons/h	2514 tons/h	2429 tons/h

			90%				85%			
			39.2 tons				37.1 tons			
			157 tons				149 tons			
Overall Mine Efficiency	Cycle Time		24 sec	26 sec	28 sec	30 sec	24 sec	26 sec	28 sec	30 sec
	Truck Exchange		0.40 min	0.43 min	0.47 min	0.50 min	0.40 min	0.43 min	0.47 min	0.50 min
83% = maximum 50 min/hour	30 sec	0.50 min	4467 tons/h	4248 tons/h	3988 tons/h	3813 tons/h	4228 tons/h	4022 tons/h	3775 tons/h	3610 tons/h
	42 sec	0.70 min	4009 tons/h	3832 tons/h	3619 tons/h	3474 tons/h	3795 tons/h	3627 tons/h	3426 tons/h	3289 tons/h
	54 sec	0.90 min	3636 tons/h	3490 tons/h	3312 tons/h	3191 tons/h	3442 tons/h	3304 tons/h	3136 tons/h	3020 tons/h
	66 sec	1.10 min	3326 tons/h	3204 tons/h	3054 tons/h	2950 tons/h	3149 tons/h	3033 tons/h	2891 tons/h	2792 tons/h
80%	30 sec	0.50 min	4289 tons/h	4079 tons/h	3830 tons/h	3662 tons/h	4060 tons/h	3862 tons/h	3625 tons/h	3466 tons/h
	42 sec	0.70 min	3849 tons/h	3680 tons/h	3475 tons/h	3336 tons/h	3644 tons/h	3483 tons/h	3290 tons/h	3158 tons/h
	54 sec	0.90 min	3491 tons/h	3351 tons/h	3181 tons/h	3064 tons/h	3305 tons/h	3172 tons/h	3011 tons/h	2900 tons/h
	66 sec	1.10 min	3194 tons/h	3076 tons/h	2932 tons/h	2833 tons/h	3024 tons/h	2912 tons/h	2776 tons/h	2681 tons/h
75%	30 sec	0.50 min	4020 tons/h	3824 tons/h	3589 tons/h	3432 tons/h	3806 tons/h	3619 tons/h	3398 tons/h	3249 tons/h
	42 sec	0.70 min	3608 tons/h	3449 tons/h	3257 tons/h	3127 tons/h	3415 tons/h	3265 tons/h	3083 tons/h	2960 tons/h
	54 sec	0.90 min	3272 tons/h	3141 tons/h	2981 tons/h	2872 tons/h	3098 tons/h	2973 tons/h	2822 tons/h	2718 tons/h
	66 sec	1.10 min	2994 tons/h	2883 tons/h	2748 tons/h	2655 tons/h	2834 tons/h	2729 tons/h	2602 tons/h	2513 tons/h
70%	30 sec	0.50 min	3751 tons/h	3568 tons/h	3349 tons/h	3202 tons/h	3551 tons/h	3377 tons/h	3170 tons/h	3031 tons/h
	42 sec	0.70 min	3366 tons/h	3218 tons/h	3039 tons/h	2918 tons/h	3187 tons/h	3046 tons/h	2877 tons/h	2762 tons/h
	54 sec	0.90 min	3053 tons/h	2931 tons/h	2782 tons/h	2679 tons/h	2890 tons/h	2774 tons/h	2633 tons/h	2536 tons/h
	66 sec	1.10 min	2793 tons/h	2690 tons/h	2564 tons/h	2477 tons/h	2644 tons/h	2547 tons/h	2427 tons/h	2345 tons/h
65%	30 sec	0.50 min	3482 tons/h	3312 tons/h	3109 tons/h	2972 tons/h	3296 tons/h	3135 tons/h	2943 tons/h	2814 tons/h
	42 sec	0.70 min	3125 tons/h	2987 tons/h	2821 tons/h	2708 tons/h	2958 tons/h	2828 tons/h	2671 tons/h	2564 tons/h
	54 sec	0.90 min	2834 tons/h	2720 tons/h	2582 tons/h	2487 tons/h	2683 tons/h	2575 tons/h	2444 tons/h	2354 tons/h
	66 sec	1.10 min	2593 tons/h	2497 tons/h	2380 tons/h	2299 tons/h	2455 tons/h	2364 tons/h	2253 tons/h	2177 tons/h

MODEL: 6050 ● Bucket Size: 28.0 m<sup>3</sup> ● Number of Cycles: 4 ● Material Density: 1.80 t/m<sup>3</sup>

		Bucket Fill Factor	100%				95%			
		Load per Bucket	50.4 t				47.9 t			
		Load per Truck	202 t				192 t			
Overall Mine Efficiency	Truck Exchange	Cycle Time	25 sec	27 sec	29 sec	31 sec	25 sec	27 sec	29 sec	31 sec
		0.42 min	0.45 min	0.48 min	0.52 min	0.42 min	0.45 min	0.48 min	0.52 min	
83% = maximum 50 min/hour	30 sec	0.50 min	5547 t/h	5284 t/h	5045 t/h	4758 t/h	5272 t/h	5022 t/h	4795 t/h	4522 t/h
	42 sec	0.70 min	4995 t/h	4781 t/h	4584 t/h	4346 t/h	4747 t/h	4544 t/h	4357 t/h	4131 t/h
	54 sec	0.90 min	4543 t/h	4365 t/h	4201 t/h	4000 t/h	4318 t/h	4149 t/h	3992 t/h	3801 t/h
	66 sec	1.10 min	4166 t/h	4016 t/h	3876 t/h	3705 t/h	3959 t/h	3817 t/h	3684 t/h	3521 t/h
80%	30 sec	0.50 min	5326 t/h	5074 t/h	4844 t/h	4569 t/h	5062 t/h	4822 t/h	4604 t/h	4342 t/h
	42 sec	0.70 min	4796 t/h	4591 t/h	4402 t/h	4173 t/h	4558 t/h	4363 t/h	4184 t/h	3966 t/h
	54 sec	0.90 min	4362 t/h	4192 t/h	4034 t/h	3841 t/h	4146 t/h	3984 t/h	3834 t/h	3650 t/h
	66 sec	1.10 min	4000 t/h	3856 t/h	3722 t/h	3557 t/h	3802 t/h	3665 t/h	3538 t/h	3381 t/h
75%	30 sec	0.50 min	4992 t/h	4756 t/h	4541 t/h	4282 t/h	4744 t/h	4520 t/h	4315 t/h	4070 t/h
	42 sec	0.70 min	4495 t/h	4303 t/h	4126 t/h	3912 t/h	4272 t/h	4089 t/h	3921 t/h	3718 t/h
	54 sec	0.90 min	4089 t/h	3929 t/h	3781 t/h	3600 t/h	3886 t/h	3734 t/h	3593 t/h	3421 t/h
	66 sec	1.10 min	3749 t/h	3614 t/h	3489 t/h	3334 t/h	3563 t/h	3435 t/h	3316 t/h	3169 t/h
70%	30 sec	0.50 min	4658 t/h	4437 t/h	4237 t/h	3996 t/h	4427 t/h	4217 t/h	4026 t/h	3797 t/h
	42 sec	0.70 min	4194 t/h	4015 t/h	3850 t/h	3650 t/h	3986 t/h	3816 t/h	3659 t/h	3469 t/h
	54 sec	0.90 min	3815 t/h	3666 t/h	3528 t/h	3359 t/h	3626 t/h	3484 t/h	3353 t/h	3192 t/h
	66 sec	1.10 min	3498 t/h	3372 t/h	3255 t/h	3111 t/h	3325 t/h	3205 t/h	3094 t/h	2957 t/h
65%	30 sec	0.50 min	4324 t/h	4119 t/h	3933 t/h	3709 t/h	4109 t/h	3915 t/h	3738 t/h	3525 t/h
	42 sec	0.70 min	3894 t/h	3727 t/h	3574 t/h	3388 t/h	3700 t/h	3542 t/h	3396 t/h	3220 t/h
	54 sec	0.90 min	3541 t/h	3403 t/h	3275 t/h	3118 t/h	3366 t/h	3234 t/h	3112 t/h	2963 t/h
	66 sec	1.10 min	3247 t/h	3130 t/h	3022 t/h	2888 t/h	3086 t/h	2975 t/h	2872 t/h	2745 t/h

		Bucket Fill Factor	90%				85%			
		Load per Bucket	45.4 t				42.8 t			
		Load per Truck	182 t				171 t			
Overall Mine Efficiency	Truck Exchange	Cycle Time	25 sec	27 sec	29 sec	31 sec	25 sec	27 sec	29 sec	31 sec
		0.42 min	0.45 min	0.48 min	0.52 min	0.42 min	0.45 min	0.48 min	0.52 min	
83% = maximum 50 min/hour	30 sec	0.50 min	4997 t/h	4760 t/h	4545 t/h	4286 t/h	4710 t/h	4487 t/h	4284 t/h	4041 t/h
	42 sec	0.70 min	4499 t/h	4307 t/h	4130 t/h	3915 t/h	4242 t/h	4060 t/h	3893 t/h	3691 t/h
	54 sec	0.90 min	4092 t/h	3932 t/h	3784 t/h	3603 t/h	3858 t/h	3707 t/h	3567 t/h	3397 t/h
	66 sec	1.10 min	3753 t/h	3617 t/h	3492 t/h	3337 t/h	3538 t/h	3410 t/h	3292 t/h	3146 t/h
80%	30 sec	0.50 min	4798 t/h	4571 t/h	4364 t/h	4116 t/h	4523 t/h	4309 t/h	4114 t/h	3880 t/h
	42 sec	0.70 min	4320 t/h	4135 t/h	3965 t/h	3759 t/h	4073 t/h	3898 t/h	3738 t/h	3544 t/h
	54 sec	0.90 min	3929 t/h	3776 t/h	3634 t/h	3460 t/h	3704 t/h	3559 t/h	3425 t/h	3262 t/h
	66 sec	1.10 min	3603 t/h	3474 t/h	3353 t/h	3204 t/h	3397 t/h	3275 t/h	3161 t/h	3021 t/h
75%	30 sec	0.50 min	4497 t/h	4284 t/h	4090 t/h	3857 t/h	4239 t/h	4039 t/h	3856 t/h	3637 t/h
	42 sec	0.70 min	4049 t/h	3876 t/h	3717 t/h	3524 t/h	3818 t/h	3654 t/h	3504 t/h	3322 t/h
	54 sec	0.90 min	3683 t/h	3539 t/h	3406 t/h	3243 t/h	3472 t/h	3336 t/h	3211 t/h	3057 t/h
	66 sec	1.10 min	3377 t/h	3256 t/h	3143 t/h	3003 t/h	3184 t/h	3069 t/h	2963 t/h	2831 t/h
70%	30 sec	0.50 min	4196 t/h	3997 t/h	3816 t/h	3599 t/h	3956 t/h	3768 t/h	3598 t/h	3393 t/h
	42 sec	0.70 min	3778 t/h	3616 t/h	3468 t/h	3288 t/h	3562 t/h	3409 t/h	3269 t/h	3099 t/h
	54 sec	0.90 min	3436 t/h	3302 t/h	3178 t/h	3026 t/h	3240 t/h	3113 t/h	2996 t/h	2852 t/h
	66 sec	1.10 min	3151 t/h	3038 t/h	2932 t/h	2802 t/h	2971 t/h	2864 t/h	2764 t/h	2642 t/h
65%	30 sec	0.50 min	3895 t/h	3710 t/h	3543 t/h	3341 t/h	3672 t/h	3498 t/h	3340 t/h	3150 t/h
	42 sec	0.70 min	3507 t/h	3357 t/h	3219 t/h	3052 t/h	3306 t/h	3165 t/h	3035 t/h	2877 t/h
	54 sec	0.90 min	3190 t/h	3065 t/h	2950 t/h	2809 t/h	3007 t/h	2890 t/h	2781 t/h	2648 t/h
	66 sec	1.10 min	2925 t/h	2820 t/h	2722 t/h	2601 t/h	2758 t/h	2658 t/h	2566 t/h	2452 t/h

**MODEL: 6050 ● Bucket Size: 36.6 yd<sup>3</sup> ● Number of Cycles: 4 ● Material Density: 3030 lb/yd<sup>3</sup>**

Overall Mine Efficiency	Bucket Fill Factor		100%				95%			
	Load per Bucket		51.6 tons				49.1 tons			
	Load per Truck		222 tons				211 tons			
Truck Exchange	Cycle Time		25 sec	27 sec	29 sec	31 sec	25 sec	27 sec	29 sec	31 sec
	30 sec	0.50 min	0.42 min	0.45 min	0.48 min	0.52 min	0.42 min	0.45 min	0.48 min	0.52 min
83% = maximum 50 min/hour	30 sec	0.50 min	5678 tons/h	5409 tons/h	5164 tons/h	4870 tons/h	5399 tons/h	5143 tons/h	4910 tons/h	4631 tons/h
	42 sec	0.70 min	5113 tons/h	4894 tons/h	4692 tons/h	4449 tons/h	4861 tons/h	4653 tons/h	4462 tons/h	4230 tons/h
	54 sec	0.90 min	4650 tons/h	4468 tons/h	4300 tons/h	4094 tons/h	4421 tons/h	4248 tons/h	4088 tons/h	3893 tons/h
	66 sec	1.10 min	4264 tons/h	4111 tons/h	3968 tons/h	3792 tons/h	4054 tons/h	3909 tons/h	3773 tons/h	3606 tons/h
80%	30 sec	0.50 min	5452 tons/h	5194 tons/h	4959 tons/h	4677 tons/h	5184 tons/h	4938 tons/h	4715 tons/h	4447 tons/h
	42 sec	0.70 min	4909 tons/h	4699 tons/h	4506 tons/h	4272 tons/h	4668 tons/h	4468 tons/h	4284 tons/h	4062 tons/h
	54 sec	0.90 min	4465 tons/h	4290 tons/h	4129 tons/h	3931 tons/h	4246 tons/h	4079 tons/h	3926 tons/h	3738 tons/h
	66 sec	1.10 min	4095 tons/h	3947 tons/h	3810 tons/h	3641 tons/h	3893 tons/h	3753 tons/h	3623 tons/h	3462 tons/h
75%	30 sec	0.50 min	5110 tons/h	4868 tons/h	4648 tons/h	4383 tons/h	4859 tons/h	4629 tons/h	4419 tons/h	4168 tons/h
	42 sec	0.70 min	4601 tons/h	4404 tons/h	4223 tons/h	4004 tons/h	4375 tons/h	4188 tons/h	4016 tons/h	3807 tons/h
	54 sec	0.90 min	4185 tons/h	4021 tons/h	3870 tons/h	3685 tons/h	3979 tons/h	3824 tons/h	3680 tons/h	3504 tons/h
	66 sec	1.10 min	3838 tons/h	3699 tons/h	3571 tons/h	3413 tons/h	3649 tons/h	3518 tons/h	3395 tons/h	3245 tons/h
70%	30 sec	0.50 min	4768 tons/h	4542 tons/h	4337 tons/h	4090 tons/h	4533 tons/h	4319 tons/h	4123 tons/h	3889 tons/h
	42 sec	0.70 min	4293 tons/h	4109 tons/h	3940 tons/h	3736 tons/h	4082 tons/h	3907 tons/h	3747 tons/h	3552 tons/h
	54 sec	0.90 min	3905 tons/h	3752 tons/h	3611 tons/h	3438 tons/h	3713 tons/h	3568 tons/h	3433 tons/h	3269 tons/h
	66 sec	1.10 min	3581 tons/h	3452 tons/h	3332 tons/h	3184 tons/h	3405 tons/h	3282 tons/h	3168 tons/h	3028 tons/h
65%	30 sec	0.50 min	4426 tons/h	4216 tons/h	4025 tons/h	3796 tons/h	4208 tons/h	4009 tons/h	3828 tons/h	3610 tons/h
	42 sec	0.70 min	3985 tons/h	3815 tons/h	3658 tons/h	3468 tons/h	3790 tons/h	3627 tons/h	3478 tons/h	3297 tons/h
	54 sec	0.90 min	3625 tons/h	3483 tons/h	3352 tons/h	3191 tons/h	3447 tons/h	3312 tons/h	3187 tons/h	3035 tons/h
	66 sec	1.10 min	3324 tons/h	3204 tons/h	3093 tons/h	2956 tons/h	3161 tons/h	3047 tons/h	2941 tons/h	2811 tons/h

Overall Mine Efficiency	Bucket Fill Factor		90%				85%			
	Load per Bucket		46.4 tons				43.9 tons			
	Load per Truck		200 tons				189 tons			
Truck Exchange	Cycle Time		25 sec	27 sec	29 sec	31 sec	25 sec	27 sec	29 sec	31 sec
	30 sec	0.50 min	0.42 min	0.45 min	0.48 min	0.52 min	0.42 min	0.45 min	0.48 min	0.52 min
83% = maximum 50 min/hour	30 sec	0.50 min	5107 tons/h	4865 tons/h	4645 tons/h	4381 tons/h	4828 tons/h	4600 tons/h	4392 tons/h	4142 tons/h
	42 sec	0.70 min	4599 tons/h	4402 tons/h	4221 tons/h	4002 tons/h	4348 tons/h	4162 tons/h	3991 tons/h	3783 tons/h
	54 sec	0.90 min	4183 tons/h	4019 tons/h	3868 tons/h	3683 tons/h	3954 tons/h	3800 tons/h	3657 tons/h	3482 tons/h
	66 sec	1.10 min	3836 tons/h	3698 tons/h	3569 tons/h	3411 tons/h	3626 tons/h	3496 tons/h	3374 tons/h	3225 tons/h
80%	30 sec	0.50 min	4904 tons/h	4672 tons/h	4461 tons/h	4207 tons/h	4636 tons/h	4417 tons/h	4217 tons/h	3977 tons/h
	42 sec	0.70 min	4416 tons/h	4227 tons/h	4053 tons/h	3843 tons/h	4175 tons/h	3996 tons/h	3832 tons/h	3633 tons/h
	54 sec	0.90 min	4017 tons/h	3859 tons/h	3714 tons/h	3537 tons/h	3797 tons/h	3649 tons/h	3511 tons/h	3343 tons/h
	66 sec	1.10 min	3683 tons/h	3551 tons/h	3427 tons/h	3276 tons/h	3482 tons/h	3357 tons/h	3240 tons/h	3097 tons/h
75%	30 sec	0.50 min	4597 tons/h	4379 tons/h	4181 tons/h	3943 tons/h	4346 tons/h	4140 tons/h	3952 tons/h	3728 tons/h
	42 sec	0.70 min	4139 tons/h	3962 tons/h	3799 tons/h	3602 tons/h	3913 tons/h	3745 tons/h	3591 tons/h	3405 tons/h
	54 sec	0.90 min	3765 tons/h	3617 tons/h	3481 tons/h	3315 tons/h	3559 tons/h	3420 tons/h	3291 tons/h	3134 tons/h
	66 sec	1.10 min	3452 tons/h	3328 tons/h	3212 tons/h	3070 tons/h	3264 tons/h	3146 tons/h	3037 tons/h	2902 tons/h
70%	30 sec	0.50 min	4289 tons/h	4086 tons/h	3901 tons/h	3679 tons/h	4055 tons/h	3863 tons/h	3688 tons/h	3478 tons/h
	42 sec	0.70 min	3862 tons/h	3697 tons/h	3545 tons/h	3361 tons/h	3651 tons/h	3495 tons/h	3351 tons/h	3177 tons/h
	54 sec	0.90 min	3513 tons/h	3375 tons/h	3248 tons/h	3093 tons/h	3321 tons/h	3191 tons/h	3071 tons/h	2924 tons/h
	66 sec	1.10 min	3221 tons/h	3105 tons/h	2997 tons/h	2865 tons/h	3045 tons/h	2936 tons/h	2834 tons/h	2708 tons/h
65%	30 sec	0.50 min	3981 tons/h	3793 tons/h	3621 tons/h	3415 tons/h	3764 tons/h	3585 tons/h	3423 tons/h	3229 tons/h
	42 sec	0.70 min	3585 tons/h	3431 tons/h	3290 tons/h	3120 tons/h	3389 tons/h	3244 tons/h	3111 tons/h	2949 tons/h
	54 sec	0.90 min	3261 tons/h	3133 tons/h	3015 tons/h	2871 tons/h	3083 tons/h	2962 tons/h	2850 tons/h	2714 tons/h
	66 sec	1.10 min	2990 tons/h	2882 tons/h	2782 tons/h	2659 tons/h	2827 tons/h	2725 tons/h	2630 tons/h	2514 tons/h

MODEL: 6050 FS ● Bucket Size: 26.0 m<sup>3</sup> ● Number of Cycles: 4 ● Material Density: 1.80 t/m<sup>3</sup>

		Bucket Fill Factor		100%				95%			
		Load per Bucket		46.8 t				44.5 t			
		Load per Truck		187 t				178 t			
Overall Mine Efficiency	Truck Exchange	Cycle Time		25 sec	27 sec	29 sec	31 sec	25 sec	27 sec	29 sec	31 sec
		0.42 min	0.45 min	0.48 min	0.52 min	0.42 min	0.45 min	0.48 min	0.52 min		
83% = maximum 50 min/hour	30 sec	0.50 min	5151 t/h	4907 t/h	4685 t/h	4418 t/h	4897 t/h	4665 t/h	4454 t/h	4201 t/h	
	42 sec	0.70 min	4638 t/h	4439 t/h	4257 t/h	4036 t/h	4410 t/h	4221 t/h	4048 t/h	3837 t/h	
	54 sec	0.90 min	4218 t/h	4053 t/h	3901 t/h	3714 t/h	4011 t/h	3854 t/h	3709 t/h	3532 t/h	
	66 sec	1.10 min	3868 t/h	3729 t/h	3599 t/h	3440 t/h	3678 t/h	3546 t/h	3423 t/h	3271 t/h	
80%	30 sec	0.50 min	4946 t/h	4712 t/h	4498 t/h	4243 t/h	4703 t/h	4480 t/h	4277 t/h	4034 t/h	
	42 sec	0.70 min	4454 t/h	4263 t/h	4088 t/h	3875 t/h	4235 t/h	4053 t/h	3887 t/h	3685 t/h	
	54 sec	0.90 min	4051 t/h	3892 t/h	3746 t/h	3566 t/h	3852 t/h	3701 t/h	3561 t/h	3391 t/h	
	66 sec	1.10 min	3714 t/h	3581 t/h	3456 t/h	3303 t/h	3532 t/h	3405 t/h	3286 t/h	3141 t/h	
75%	30 sec	0.50 min	4636 t/h	4416 t/h	4216 t/h	3976 t/h	4408 t/h	4199 t/h	4009 t/h	3781 t/h	
	42 sec	0.70 min	4174 t/h	3995 t/h	3831 t/h	3632 t/h	3969 t/h	3799 t/h	3643 t/h	3454 t/h	
	54 sec	0.90 min	3797 t/h	3648 t/h	3511 t/h	3343 t/h	3610 t/h	3469 t/h	3338 t/h	3178 t/h	
	66 sec	1.10 min	3481 t/h	3356 t/h	3239 t/h	3096 t/h	3310 t/h	3191 t/h	3080 t/h	2944 t/h	
70%	30 sec	0.50 min	4325 t/h	4120 t/h	3934 t/h	3710 t/h	4113 t/h	3918 t/h	3741 t/h	3528 t/h	
	42 sec	0.70 min	3895 t/h	3728 t/h	3575 t/h	3389 t/h	3703 t/h	3545 t/h	3399 t/h	3222 t/h	
	54 sec	0.90 min	3542 t/h	3404 t/h	3276 t/h	3119 t/h	3368 t/h	3237 t/h	3115 t/h	2966 t/h	
	66 sec	1.10 min	3248 t/h	3131 t/h	3023 t/h	2889 t/h	3089 t/h	2978 t/h	2874 t/h	2747 t/h	
65%	30 sec	0.50 min	4015 t/h	3825 t/h	3652 t/h	3444 t/h	3818 t/h	3637 t/h	3472 t/h	3275 t/h	
	42 sec	0.70 min	3615 t/h	3461 t/h	3318 t/h	3146 t/h	3438 t/h	3290 t/h	3155 t/h	2991 t/h	
	54 sec	0.90 min	3288 t/h	3160 t/h	3041 t/h	2895 t/h	3127 t/h	3004 t/h	2891 t/h	2753 t/h	
	66 sec	1.10 min	3015 t/h	2907 t/h	2806 t/h	2682 t/h	2867 t/h	2764 t/h	2668 t/h	2550 t/h	

		Bucket Fill Factor		90%				85%			
		Load per Bucket		42.1 t				39.8 t			
		Load per Truck		168 t				159 t			
Overall Mine Efficiency	Truck Exchange	Cycle Time		25 sec	27 sec	29 sec	31 sec	25 sec	27 sec	29 sec	31 sec
		0.42 min	0.45 min	0.48 min	0.52 min	0.42 min	0.45 min	0.48 min	0.52 min		
83% = maximum 50 min/hour	30 sec	0.50 min	4633 t/h	4414 t/h	4214 t/h	3975 t/h	4380 t/h	4173 t/h	3984 t/h	3757 t/h	
	42 sec	0.70 min	4172 t/h	3993 t/h	3829 t/h	3630 t/h	3944 t/h	3775 t/h	3620 t/h	3432 t/h	
	54 sec	0.90 min	3795 t/h	3646 t/h	3509 t/h	3341 t/h	3587 t/h	3447 t/h	3317 t/h	3159 t/h	
	66 sec	1.10 min	3480 t/h	3355 t/h	3238 t/h	3095 t/h	3290 t/h	3171 t/h	3061 t/h	2926 t/h	
80%	30 sec	0.50 min	4449 t/h	4238 t/h	4047 t/h	3817 t/h	4206 t/h	4007 t/h	3826 t/h	3608 t/h	
	42 sec	0.70 min	4006 t/h	3835 t/h	3677 t/h	3486 t/h	3788 t/h	3625 t/h	3476 t/h	3296 t/h	
	54 sec	0.90 min	3644 t/h	3501 t/h	3369 t/h	3208 t/h	3445 t/h	3310 t/h	3185 t/h	3033 t/h	
	66 sec	1.10 min	3341 t/h	3221 t/h	3109 t/h	2972 t/h	3159 t/h	3045 t/h	2939 t/h	2809 t/h	
75%	30 sec	0.50 min	4170 t/h	3972 t/h	3793 t/h	3577 t/h	3942 t/h	3755 t/h	3586 t/h	3382 t/h	
	42 sec	0.70 min	3755 t/h	3594 t/h	3446 t/h	3267 t/h	3550 t/h	3398 t/h	3258 t/h	3089 t/h	
	54 sec	0.90 min	3415 t/h	3282 t/h	3158 t/h	3007 t/h	3229 t/h	3102 t/h	2985 t/h	2843 t/h	
	66 sec	1.10 min	3132 t/h	3019 t/h	2914 t/h	2785 t/h	2961 t/h	2854 t/h	2755 t/h	2633 t/h	
70%	30 sec	0.50 min	3891 t/h	3707 t/h	3539 t/h	3338 t/h	3678 t/h	3504 t/h	3346 t/h	3155 t/h	
	42 sec	0.70 min	3504 t/h	3354 t/h	3216 t/h	3049 t/h	3312 t/h	3170 t/h	3040 t/h	2882 t/h	
	54 sec	0.90 min	3187 t/h	3062 t/h	2947 t/h	2806 t/h	3013 t/h	2895 t/h	2786 t/h	2652 t/h	
	66 sec	1.10 min	2922 t/h	2817 t/h	2719 t/h	2599 t/h	2763 t/h	2663 t/h	2571 t/h	2457 t/h	
65%	30 sec	0.50 min	3612 t/h	3441 t/h	3285 t/h	3098 t/h	3414 t/h	3253 t/h	3106 t/h	2929 t/h	
	42 sec	0.70 min	3252 t/h	3113 t/h	2985 t/h	2830 t/h	3075 t/h	2943 t/h	2822 t/h	2675 t/h	
	54 sec	0.90 min	2958 t/h	2842 t/h	2735 t/h	2604 t/h	2796 t/h	2687 t/h	2586 t/h	2462 t/h	
	66 sec	1.10 min	2713 t/h	2615 t/h	2524 t/h	2412 t/h	2564 t/h	2472 t/h	2386 t/h	2280 t/h	



**MODEL: 6050 FS ● Bucket Size: 34.0 yd<sup>3</sup> ● Number of Cycles: 4 ● Material Density: 3030 lb/yd<sup>3</sup>**

Overall Mine Efficiency	Bucket Fill Factor		100%				95%			
	Load per Bucket		51.6 tons				49.1 tons			
	Load per Truck		206 tons				196 tons			
Truck Exchange	Cycle Time		25 sec	27 sec	29 sec	31 sec	25 sec	27 sec	29 sec	31 sec
	0.42 min	0.45 min	0.48 min	0.52 min	0.42 min	0.45 min	0.48 min	0.52 min		
83% = maximum 50 min/hour	30 sec	0.50 min	5678 tons/h	5409 tons/h	5164 tons/h	4870 tons/h	5399 tons/h	5143 tons/h	4910 tons/h	4631 tons/h
	42 sec	0.70 min	5113 tons/h	4894 tons/h	4692 tons/h	4449 tons/h	4861 tons/h	4653 tons/h	4462 tons/h	4230 tons/h
	54 sec	0.90 min	4650 tons/h	4468 tons/h	4300 tons/h	4094 tons/h	4421 tons/h	4248 tons/h	4088 tons/h	3893 tons/h
	66 sec	1.10 min	4264 tons/h	4111 tons/h	3968 tons/h	3792 tons/h	4054 tons/h	3909 tons/h	3773 tons/h	3606 tons/h
80%	30 sec	0.50 min	5452 tons/h	5194 tons/h	4959 tons/h	4677 tons/h	5184 tons/h	4938 tons/h	4715 tons/h	4447 tons/h
	42 sec	0.70 min	4909 tons/h	4699 tons/h	4506 tons/h	4272 tons/h	4668 tons/h	4468 tons/h	4284 tons/h	4062 tons/h
	54 sec	0.90 min	4465 tons/h	4290 tons/h	4129 tons/h	3931 tons/h	4246 tons/h	4079 tons/h	3926 tons/h	3738 tons/h
	66 sec	1.10 min	4095 tons/h	3947 tons/h	3810 tons/h	3641 tons/h	3893 tons/h	3753 tons/h	3623 tons/h	3462 tons/h
75%	30 sec	0.50 min	5110 tons/h	4868 tons/h	4648 tons/h	4383 tons/h	4859 tons/h	4629 tons/h	4419 tons/h	4168 tons/h
	42 sec	0.70 min	4601 tons/h	4404 tons/h	4223 tons/h	4004 tons/h	4375 tons/h	4188 tons/h	4016 tons/h	3807 tons/h
	54 sec	0.90 min	4185 tons/h	4021 tons/h	3870 tons/h	3685 tons/h	3979 tons/h	3824 tons/h	3680 tons/h	3504 tons/h
	66 sec	1.10 min	3838 tons/h	3699 tons/h	3571 tons/h	3413 tons/h	3649 tons/h	3518 tons/h	3395 tons/h	3245 tons/h
70%	30 sec	0.50 min	4768 tons/h	4542 tons/h	4337 tons/h	4090 tons/h	4533 tons/h	4319 tons/h	4123 tons/h	3889 tons/h
	42 sec	0.70 min	4293 tons/h	4109 tons/h	3940 tons/h	3736 tons/h	4082 tons/h	3907 tons/h	3747 tons/h	3552 tons/h
	54 sec	0.90 min	3905 tons/h	3752 tons/h	3611 tons/h	3438 tons/h	3713 tons/h	3568 tons/h	3433 tons/h	3269 tons/h
	66 sec	1.10 min	3581 tons/h	3452 tons/h	3332 tons/h	3184 tons/h	3405 tons/h	3282 tons/h	3168 tons/h	3028 tons/h
65%	30 sec	0.50 min	4426 tons/h	4216 tons/h	4025 tons/h	3796 tons/h	4208 tons/h	4009 tons/h	3828 tons/h	3610 tons/h
	42 sec	0.70 min	3985 tons/h	3815 tons/h	3658 tons/h	3468 tons/h	3790 tons/h	3627 tons/h	3478 tons/h	3297 tons/h
	54 sec	0.90 min	3625 tons/h	3483 tons/h	3352 tons/h	3191 tons/h	3447 tons/h	3312 tons/h	3187 tons/h	3035 tons/h
	66 sec	1.10 min	3324 tons/h	3204 tons/h	3093 tons/h	2956 tons/h	3161 tons/h	3047 tons/h	2941 tons/h	2811 tons/h

Overall Mine Efficiency	Bucket Fill Factor		90%				85%			
	Load per Bucket		46.4 tons				43.9 tons			
	Load per Truck		186 tons				175 tons			
Truck Exchange	Cycle Time		25 sec	27 sec	29 sec	31 sec	25 sec	27 sec	29 sec	31 sec
	0.42 min	0.45 min	0.48 min	0.52 min	0.42 min	0.45 min	0.48 min	0.52 min		
83% = maximum 50 min/hour	30 sec	0.50 min	5107 tons/h	4865 tons/h	4645 tons/h	4381 tons/h	4828 tons/h	4600 tons/h	4392 tons/h	4142 tons/h
	42 sec	0.70 min	4599 tons/h	4402 tons/h	4221 tons/h	4002 tons/h	4348 tons/h	4162 tons/h	3991 tons/h	3783 tons/h
	54 sec	0.90 min	4183 tons/h	4019 tons/h	3868 tons/h	3683 tons/h	3954 tons/h	3800 tons/h	3657 tons/h	3482 tons/h
	66 sec	1.10 min	3836 tons/h	3698 tons/h	3569 tons/h	3411 tons/h	3626 tons/h	3496 tons/h	3374 tons/h	3225 tons/h
80%	30 sec	0.50 min	4904 tons/h	4672 tons/h	4461 tons/h	4207 tons/h	4636 tons/h	4417 tons/h	4217 tons/h	3977 tons/h
	42 sec	0.70 min	4416 tons/h	4227 tons/h	4053 tons/h	3843 tons/h	4175 tons/h	3996 tons/h	3832 tons/h	3633 tons/h
	54 sec	0.90 min	4017 tons/h	3859 tons/h	3714 tons/h	3537 tons/h	3797 tons/h	3649 tons/h	3511 tons/h	3343 tons/h
	66 sec	1.10 min	3683 tons/h	3551 tons/h	3427 tons/h	3276 tons/h	3482 tons/h	3357 tons/h	3240 tons/h	3097 tons/h
75%	30 sec	0.50 min	4597 tons/h	4379 tons/h	4181 tons/h	3943 tons/h	4346 tons/h	4140 tons/h	3952 tons/h	3728 tons/h
	42 sec	0.70 min	4139 tons/h	3962 tons/h	3799 tons/h	3602 tons/h	3913 tons/h	3745 tons/h	3591 tons/h	3405 tons/h
	54 sec	0.90 min	3765 tons/h	3617 tons/h	3481 tons/h	3315 tons/h	3559 tons/h	3420 tons/h	3291 tons/h	3134 tons/h
	66 sec	1.10 min	3452 tons/h	3328 tons/h	3212 tons/h	3070 tons/h	3264 tons/h	3146 tons/h	3037 tons/h	2902 tons/h
70%	30 sec	0.50 min	4289 tons/h	4086 tons/h	3901 tons/h	3679 tons/h	4055 tons/h	3863 tons/h	3688 tons/h	3478 tons/h
	42 sec	0.70 min	3862 tons/h	3697 tons/h	3545 tons/h	3361 tons/h	3651 tons/h	3495 tons/h	3351 tons/h	3177 tons/h
	54 sec	0.90 min	3513 tons/h	3375 tons/h	3248 tons/h	3093 tons/h	3321 tons/h	3191 tons/h	3071 tons/h	2924 tons/h
	66 sec	1.10 min	3221 tons/h	3105 tons/h	2997 tons/h	2865 tons/h	3045 tons/h	2936 tons/h	2834 tons/h	2708 tons/h
65%	30 sec	0.50 min	3981 tons/h	3793 tons/h	3621 tons/h	3415 tons/h	3764 tons/h	3585 tons/h	3423 tons/h	3229 tons/h
	42 sec	0.70 min	3585 tons/h	3431 tons/h	3290 tons/h	3120 tons/h	3389 tons/h	3244 tons/h	3111 tons/h	2949 tons/h
	54 sec	0.90 min	3261 tons/h	3133 tons/h	3015 tons/h	2871 tons/h	3083 tons/h	2962 tons/h	2850 tons/h	2714 tons/h
	66 sec	1.10 min	2990 tons/h	2882 tons/h	2782 tons/h	2659 tons/h	2827 tons/h	2725 tons/h	2630 tons/h	2514 tons/h

MODEL: 6060 and 6060 FS ● Bucket Size: 34.0 m<sup>3</sup> ● Number of Cycles: 4  
● Material Density: 1.80 t/m<sup>3</sup>

		Bucket Fill Factor		100%				95%			
		Load per Bucket		61.2 t				58.1 t			
		Load per Truck		245 t				232 t			
Overall Mine Efficiency	Truck Exchange	Cycle Time		26 sec	28 sec	30 sec	32 sec	26 sec	28 sec	30 sec	32 sec
		30 sec	0.50 min	0.43 min	0.47 min	0.50 min	0.53 min	0.43 min	0.47 min	0.50 min	0.53 min
83% = maximum 50 min/hour	30 sec	0.50 min	6626 t/h	6220 t/h	5947 t/h	5697 t/h	6290 t/h	5905 t/h	5646 t/h	5408 t/h	
	42 sec	0.70 min	5976 t/h	5644 t/h	5418 t/h	5210 t/h	5673 t/h	5358 t/h	5144 t/h	4946 t/h	
	54 sec	0.90 min	5442 t/h	5166 t/h	4976 t/h	4800 t/h	5167 t/h	4904 t/h	4724 t/h	4557 t/h	
	66 sec	1.10 min	4996 t/h	4762 t/h	4600 t/h	4449 t/h	4743 t/h	4521 t/h	4367 t/h	4224 t/h	
80%	30 sec	0.50 min	6362 t/h	5973 t/h	5710 t/h	5470 t/h	6040 t/h	5670 t/h	5421 t/h	5193 t/h	
	42 sec	0.70 min	5738 t/h	5420 t/h	5203 t/h	5003 t/h	5448 t/h	5145 t/h	4939 t/h	4749 t/h	
	54 sec	0.90 min	5226 t/h	4960 t/h	4778 t/h	4609 t/h	4961 t/h	4709 t/h	4536 t/h	4375 t/h	
	66 sec	1.10 min	4798 t/h	4573 t/h	4417 t/h	4272 t/h	4555 t/h	4341 t/h	4194 t/h	4056 t/h	
75%	30 sec	0.50 min	5963 t/h	5598 t/h	5352 t/h	5127 t/h	5661 t/h	5314 t/h	5081 t/h	4867 t/h	
	42 sec	0.70 min	5378 t/h	5080 t/h	4876 t/h	4689 t/h	5106 t/h	4822 t/h	4629 t/h	4451 t/h	
	54 sec	0.90 min	4898 t/h	4649 t/h	4478 t/h	4320 t/h	4650 t/h	4414 t/h	4251 t/h	4101 t/h	
	66 sec	1.10 min	4497 t/h	4286 t/h	4140 t/h	4004 t/h	4269 t/h	4069 t/h	3931 t/h	3802 t/h	
70%	30 sec	0.50 min	5564 t/h	5223 t/h	4994 t/h	4784 t/h	5282 t/h	4959 t/h	4741 t/h	4542 t/h	
	42 sec	0.70 min	5018 t/h	4740 t/h	4550 t/h	4375 t/h	4764 t/h	4500 t/h	4320 t/h	4153 t/h	
	54 sec	0.90 min	4570 t/h	4338 t/h	4179 t/h	4031 t/h	4339 t/h	4118 t/h	3967 t/h	3826 t/h	
	66 sec	1.10 min	4196 t/h	3999 t/h	3863 t/h	3736 t/h	3983 t/h	3796 t/h	3668 t/h	3547 t/h	
65%	30 sec	0.50 min	5165 t/h	4849 t/h	4636 t/h	4441 t/h	4903 t/h	4603 t/h	4401 t/h	4216 t/h	
	42 sec	0.70 min	4658 t/h	4400 t/h	4224 t/h	4061 t/h	4422 t/h	4177 t/h	4010 t/h	3855 t/h	
	54 sec	0.90 min	4242 t/h	4027 t/h	3879 t/h	3741 t/h	4028 t/h	3823 t/h	3682 t/h	3552 t/h	
	66 sec	1.10 min	3895 t/h	3712 t/h	3586 t/h	3468 t/h	3697 t/h	3524 t/h	3404 t/h	3293 t/h	

		Bucket Fill Factor		90%				85%			
		Load per Bucket		55.1 t				52.0 t			
		Load per Truck		220 t				208 t			
Overall Mine Efficiency	Truck Exchange	Cycle Time		26 sec	28 sec	30 sec	32 sec	26 sec	28 sec	30 sec	32 sec
		30 sec	0.50 min	0.43 min	0.47 min	0.50 min	0.53 min	0.43 min	0.47 min	0.50 min	0.53 min
83% = maximum 50 min/hour	30 sec	0.50 min	5965 t/h	5600 t/h	5354 t/h	5129 t/h	5630 t/h	5285 t/h	5053 t/h	4840 t/h	
	42 sec	0.70 min	5380 t/h	5081 t/h	4878 t/h	4691 t/h	5078 t/h	4796 t/h	4604 t/h	4427 t/h	
	54 sec	0.90 min	4900 t/h	4651 t/h	4480 t/h	4321 t/h	4624 t/h	4389 t/h	4228 t/h	4078 t/h	
	66 sec	1.10 min	4498 t/h	4287 t/h	4142 t/h	4006 t/h	4245 t/h	4046 t/h	3909 t/h	3780 t/h	
80%	30 sec	0.50 min	5728 t/h	5377 t/h	5141 t/h	4925 t/h	5406 t/h	5075 t/h	4852 t/h	4648 t/h	
	42 sec	0.70 min	5166 t/h	4879 t/h	4684 t/h	4504 t/h	4876 t/h	4605 t/h	4421 t/h	4251 t/h	
	54 sec	0.90 min	4705 t/h	4466 t/h	4302 t/h	4149 t/h	4440 t/h	4215 t/h	4060 t/h	3916 t/h	
	66 sec	1.10 min	4319 t/h	4117 t/h	3977 t/h	3847 t/h	4076 t/h	3885 t/h	3753 t/h	3630 t/h	
75%	30 sec	0.50 min	5369 t/h	5040 t/h	4819 t/h	4616 t/h	5067 t/h	4756 t/h	4548 t/h	4356 t/h	
	42 sec	0.70 min	4842 t/h	4573 t/h	4390 t/h	4222 t/h	4570 t/h	4316 t/h	4143 t/h	3984 t/h	
	54 sec	0.90 min	4410 t/h	4186 t/h	4032 t/h	3889 t/h	4162 t/h	3950 t/h	3805 t/h	3670 t/h	
	66 sec	1.10 min	4048 t/h	3859 t/h	3728 t/h	3605 t/h	3821 t/h	3642 t/h	3518 t/h	3402 t/h	
70%	30 sec	0.50 min	5009 t/h	4703 t/h	4496 t/h	4307 t/h	4727 t/h	4438 t/h	4243 t/h	4065 t/h	
	42 sec	0.70 min	4518 t/h	4267 t/h	4097 t/h	3939 t/h	4264 t/h	4027 t/h	3866 t/h	3717 t/h	
	54 sec	0.90 min	4115 t/h	3906 t/h	3762 t/h	3629 t/h	3883 t/h	3686 t/h	3550 t/h	3425 t/h	
	66 sec	1.10 min	3778 t/h	3600 t/h	3478 t/h	3364 t/h	3565 t/h	3398 t/h	3282 t/h	3175 t/h	
65%	30 sec	0.50 min	4650 t/h	4365 t/h	4174 t/h	3998 t/h	4388 t/h	4120 t/h	3939 t/h	3773 t/h	
	42 sec	0.70 min	4194 t/h	3961 t/h	3803 t/h	3656 t/h	3958 t/h	3738 t/h	3589 t/h	3451 t/h	
	54 sec	0.90 min	3820 t/h	3625 t/h	3492 t/h	3368 t/h	3605 t/h	3421 t/h	3296 t/h	3179 t/h	
	66 sec	1.10 min	3507 t/h	3342 t/h	3229 t/h	3123 t/h	3309 t/h	3154 t/h	3047 t/h	2947 t/h	

**MODEL: 6060 and 6060 FS** ● **Bucket Size: 44.5 yd<sup>3</sup>** ● **Number of Cycles: 4**  
 ● **Material Density: 3030 lb/yd<sup>3</sup>**

			Bucket Fill Factor		100%				95%			
			Load per Bucket		67.5 tons				64.0 tons			
			Load per Truck		270 tons				256 tons			
Overall Mine Efficiency	Cycle Time		26 sec	28 sec	30 sec	32 sec	26 sec	28 sec	30 sec	32 sec		
	Truck Exchange		0.43 min	0.47 min	0.50 min	0.53 min	0.43 min	0.47 min	0.50 min	0.53 min		
83% = maximum 50 min/hour	30 sec	0.50 min	7303 tons/h	6856 tons/h	6555 tons/h	6280 tons/h	6933 tons/h	6509 tons/h	6223 tons/h	5962 tons/h		
	42 sec	0.70 min	6587 tons/h	6221 tons/h	5973 tons/h	5743 tons/h	6254 tons/h	5906 tons/h	5670 tons/h	5452 tons/h		
	54 sec	0.90 min	5999 tons/h	5694 tons/h	5485 tons/h	5291 tons/h	5695 tons/h	5406 tons/h	5207 tons/h	5023 tons/h		
	66 sec	1.10 min	5508 tons/h	5249 tons/h	5071 tons/h	4904 tons/h	5229 tons/h	4983 tons/h	4814 tons/h	4656 tons/h		
80%	30 sec	0.50 min	7013 tons/h	6584 tons/h	6295 tons/h	6030 tons/h	6658 tons/h	6250 tons/h	5976 tons/h	5724 tons/h		
	42 sec	0.70 min	6326 tons/h	5974 tons/h	5735 tons/h	5515 tons/h	6005 tons/h	5671 tons/h	5445 tons/h	5235 tons/h		
	54 sec	0.90 min	5761 tons/h	5468 tons/h	5267 tons/h	5080 tons/h	5469 tons/h	5191 tons/h	5000 tons/h	4823 tons/h		
	66 sec	1.10 min	5289 tons/h	5041 tons/h	4869 tons/h	4709 tons/h	5021 tons/h	4785 tons/h	4623 tons/h	4471 tons/h		
75%	30 sec	0.50 min	6573 tons/h	6171 tons/h	5900 tons/h	5652 tons/h	6240 tons/h	5858 tons/h	5601 tons/h	5365 tons/h		
	42 sec	0.70 min	5929 tons/h	5599 tons/h	5375 tons/h	5169 tons/h	5628 tons/h	5316 tons/h	5103 tons/h	4907 tons/h		
	54 sec	0.90 min	5399 tons/h	5125 tons/h	4937 tons/h	4762 tons/h	5126 tons/h	4865 tons/h	4686 tons/h	4520 tons/h		
	66 sec	1.10 min	4957 tons/h	4724 tons/h	4564 tons/h	4414 tons/h	4706 tons/h	4485 tons/h	4333 tons/h	4190 tons/h		
70%	30 sec	0.50 min	6133 tons/h	5758 tons/h	5505 tons/h	5273 tons/h	5822 tons/h	5466 tons/h	5226 tons/h	5006 tons/h		
	42 sec	0.70 min	5532 tons/h	5225 tons/h	5016 tons/h	4823 tons/h	5252 tons/h	4960 tons/h	4761 tons/h	4578 tons/h		
	54 sec	0.90 min	5038 tons/h	4782 tons/h	4606 tons/h	4443 tons/h	4783 tons/h	4540 tons/h	4373 tons/h	4218 tons/h		
	66 sec	1.10 min	4625 tons/h	4408 tons/h	4258 tons/h	4119 tons/h	4391 tons/h	4185 tons/h	4043 tons/h	3910 tons/h		
65%	30 sec	0.50 min	5693 tons/h	5345 tons/h	5110 tons/h	4895 tons/h	5405 tons/h	5074 tons/h	4851 tons/h	4647 tons/h		
	42 sec	0.70 min	5135 tons/h	4850 tons/h	4656 tons/h	4477 tons/h	4875 tons/h	4604 tons/h	4420 tons/h	4250 tons/h		
	54 sec	0.90 min	4677 tons/h	4439 tons/h	4276 tons/h	4124 tons/h	4440 tons/h	4214 tons/h	4059 tons/h	3915 tons/h		
	66 sec	1.10 min	4293 tons/h	4092 tons/h	3953 tons/h	3823 tons/h	4076 tons/h	3885 tons/h	3753 tons/h	3629 tons/h		

			Bucket Fill Factor		90%				85%			
			Load per Bucket		60.7 tons				57.3 tons			
			Load per Truck		243 tons				229 tons			
Overall Mine Efficiency	Cycle Time		26 sec	28 sec	30 sec	32 sec	26 sec	28 sec	30 sec	32 sec		
	Truck Exchange		0.43 min	0.47 min	0.50 min	0.53 min	0.43 min	0.47 min	0.50 min	0.53 min		
83% = maximum 50 min/hour	30 sec	0.50 min	6575 tons/h	6173 tons/h	5902 tons/h	5654 tons/h	6206 tons/h	5826 tons/h	5570 tons/h	5336 tons/h		
	42 sec	0.70 min	5931 tons/h	5601 tons/h	5377 tons/h	5170 tons/h	5597 tons/h	5286 tons/h	5075 tons/h	4880 tons/h		
	54 sec	0.90 min	5401 tons/h	5127 tons/h	4938 tons/h	4763 tons/h	5097 tons/h	4838 tons/h	4660 tons/h	4495 tons/h		
	66 sec	1.10 min	4959 tons/h	4726 tons/h	4566 tons/h	4416 tons/h	4680 tons/h	4460 tons/h	4309 tons/h	4167 tons/h		
80%	30 sec	0.50 min	6314 tons/h	5927 tons/h	5667 tons/h	5429 tons/h	5959 tons/h	5594 tons/h	5348 tons/h	5123 tons/h		
	42 sec	0.70 min	5695 tons/h	5379 tons/h	5163 tons/h	4965 tons/h	5375 tons/h	5076 tons/h	4873 tons/h	4686 tons/h		
	54 sec	0.90 min	5187 tons/h	4923 tons/h	4742 tons/h	4574 tons/h	4895 tons/h	4646 tons/h	4475 tons/h	4317 tons/h		
	66 sec	1.10 min	4761 tons/h	4538 tons/h	4384 tons/h	4240 tons/h	4494 tons/h	4283 tons/h	4137 tons/h	4002 tons/h		
75%	30 sec	0.50 min	5918 tons/h	5556 tons/h	5312 tons/h	5088 tons/h	5585 tons/h	5243 tons/h	5013 tons/h	4802 tons/h		
	42 sec	0.70 min	5338 tons/h	5041 tons/h	4840 tons/h	4653 tons/h	5037 tons/h	4758 tons/h	4567 tons/h	4392 tons/h		
	54 sec	0.90 min	4861 tons/h	4614 tons/h	4444 tons/h	4287 tons/h	4588 tons/h	4354 tons/h	4194 tons/h	4046 tons/h		
	66 sec	1.10 min	4463 tons/h	4254 tons/h	4109 tons/h	3974 tons/h	4212 tons/h	4014 tons/h	3878 tons/h	3750 tons/h		
70%	30 sec	0.50 min	5522 tons/h	5184 tons/h	4956 tons/h	4748 tons/h	5211 tons/h	4892 tons/h	4677 tons/h	4481 tons/h		
	42 sec	0.70 min	4980 tons/h	4704 tons/h	4516 tons/h	4342 tons/h	4700 tons/h	4429 tons/h	4262 tons/h	4098 tons/h		
	54 sec	0.90 min	4536 tons/h	4305 tons/h	4147 tons/h	4000 tons/h	4281 tons/h	4063 tons/h	3914 tons/h	3775 tons/h		
	66 sec	1.10 min	4164 tons/h	3969 tons/h	3834 tons/h	3708 tons/h	3930 tons/h	3746 tons/h	3618 tons/h	3499 tons/h		
65%	30 sec	0.50 min	5126 tons/h	4812 tons/h	4601 tons/h	4407 tons/h	4837 tons/h	4541 tons/h	4342 tons/h	4159 tons/h		
	42 sec	0.70 min	4623 tons/h	4366 tons/h	4192 tons/h	4030 tons/h	4363 tons/h	4121 tons/h	3956 tons/h	3804 tons/h		
	54 sec	0.90 min	4210 tons/h	3996 tons/h	3850 tons/h	3713 tons/h	3974 tons/h	3771 tons/h	3633 tons/h	3504 tons/h		
	66 sec	1.10 min	3865 tons/h	3684 tons/h	3559 tons/h	3442 tons/h	3648 tons/h	3477 tons/h	3359 tons/h	3248 tons/h		

MODEL: 6090 FS ● Bucket Size: 52.0 m<sup>3</sup> ● Number of Cycles: 4 ● Material Density: 1.80 t/m<sup>3</sup>

Overall Mine Efficiency	Bucket Fill Factor		100%				95%			
	Load per Bucket		93.6 t				88.9 t			
	Load per Truck		374 t				356 t			
Truck Exchange	Cycle Time		28 sec	30 sec	32 sec	34 sec	28 sec	30 sec	32 sec	34 sec
	0.47 min	0.50 min	0.53 min	0.57 min	0.47 min	0.50 min	0.53 min	0.57 min		
83% = maximum 50 min/hour	30 sec	0.50 min	9513 t/h	9095 t/h	8713 t/h	N/A	9035 t/h	8638 t/h	8275 t/h	N/A
	42 sec	0.70 min	8632 t/h	8287 t/h	7968 t/h	7579 t/h	8199 t/h	7871 t/h	7568 t/h	7199 t/h
	54 sec	0.90 min	7900 t/h	7610 t/h	7341 t/h	7009 t/h	7504 t/h	7228 t/h	6972 t/h	6657 t/h
	66 sec	1.10 min	7283 t/h	7036 t/h	6805 t/h	6519 t/h	6918 t/h	6683 t/h	6463 t/h	6192 t/h
80%	30 sec	0.50 min	9135 t/h	8734 t/h	8366 t/h	N/A	8676 t/h	8295 t/h	7946 t/h	N/A
	42 sec	0.70 min	8289 t/h	7957 t/h	7651 t/h	7278 t/h	7873 t/h	7558 t/h	7267 t/h	6913 t/h
	54 sec	0.90 min	7586 t/h	7308 t/h	7049 t/h	6731 t/h	7205 t/h	6941 t/h	6695 t/h	6393 t/h
	66 sec	1.10 min	6994 t/h	6756 t/h	6534 t/h	6260 t/h	6642 t/h	6417 t/h	6206 t/h	5946 t/h
75%	30 sec	0.50 min	8562 t/h	8186 t/h	7841 t/h	N/A	8132 t/h	7775 t/h	7448 t/h	N/A
	42 sec	0.70 min	7769 t/h	7458 t/h	7171 t/h	6821 t/h	7379 t/h	7084 t/h	6811 t/h	6479 t/h
	54 sec	0.90 min	7110 t/h	6849 t/h	6607 t/h	6308 t/h	6753 t/h	6505 t/h	6275 t/h	5992 t/h
	66 sec	1.10 min	6555 t/h	6332 t/h	6124 t/h	5867 t/h	6226 t/h	6014 t/h	5817 t/h	5573 t/h
70%	30 sec	0.50 min	7988 t/h	7638 t/h	7317 t/h	N/A	7587 t/h	7254 t/h	6949 t/h	N/A
	42 sec	0.70 min	7249 t/h	6959 t/h	6691 t/h	6365 t/h	6885 t/h	6609 t/h	6355 t/h	6045 t/h
	54 sec	0.90 min	6634 t/h	6391 t/h	6164 t/h	5886 t/h	6301 t/h	6070 t/h	5855 t/h	5591 t/h
	66 sec	1.10 min	6116 t/h	5908 t/h	5714 t/h	5475 t/h	5809 t/h	5612 t/h	5427 t/h	5200 t/h
65%	30 sec	0.50 min	7415 t/h	7090 t/h	6792 t/h	N/A	7043 t/h	6734 t/h	6451 t/h	N/A
	42 sec	0.70 min	6729 t/h	6460 t/h	6211 t/h	5908 t/h	6391 t/h	6135 t/h	5899 t/h	5612 t/h
	54 sec	0.90 min	6159 t/h	5932 t/h	5722 t/h	5464 t/h	5849 t/h	5634 t/h	5435 t/h	5190 t/h
	66 sec	1.10 min	5677 t/h	5485 t/h	5304 t/h	5082 t/h	5392 t/h	5209 t/h	5038 t/h	4827 t/h

Overall Mine Efficiency	Bucket Fill Factor		90%				85%			
	Load per Bucket		84.2 t				79.6 t			
	Load per Truck		337 t				318 t			
Truck Exchange	Cycle Time		28 sec	30 sec	32 sec	34 sec	28 sec	30 sec	32 sec	34 sec
	0.47 min	0.50 min	0.53 min	0.57 min	0.47 min	0.50 min	0.53 min	0.57 min		
83% = maximum 50 min/hour	30 sec	0.50 min	8557 t/h	8182 t/h	7838 t/h	N/A	8090 t/h	7735 t/h	7409 t/h	N/A
	42 sec	0.70 min	7765 t/h	7455 t/h	7168 t/h	6818 t/h	7341 t/h	7047 t/h	6776 t/h	6446 t/h
	54 sec	0.90 min	7107 t/h	6846 t/h	6603 t/h	6306 t/h	6719 t/h	6472 t/h	6243 t/h	5961 t/h
	66 sec	1.10 min	6552 t/h	6329 t/h	6121 t/h	5865 t/h	6194 t/h	5984 t/h	5787 t/h	5544 t/h
80%	30 sec	0.50 min	8217 t/h	7856 t/h	7526 t/h	N/A	7768 t/h	7427 t/h	7115 t/h	N/A
	42 sec	0.70 min	7456 t/h	7158 t/h	6883 t/h	6547 t/h	7049 t/h	6767 t/h	6507 t/h	6189 t/h
	54 sec	0.90 min	6824 t/h	6574 t/h	6341 t/h	6055 t/h	6452 t/h	6215 t/h	5994 t/h	5724 t/h
	66 sec	1.10 min	6291 t/h	6078 t/h	5878 t/h	5631 t/h	5948 t/h	5746 t/h	5557 t/h	5324 t/h
75%	30 sec	0.50 min	7702 t/h	7364 t/h	7054 t/h	N/A	7281 t/h	6961 t/h	6669 t/h	N/A
	42 sec	0.70 min	6989 t/h	6709 t/h	6451 t/h	6136 t/h	6607 t/h	6343 t/h	6099 t/h	5801 t/h
	54 sec	0.90 min	6396 t/h	6161 t/h	5943 t/h	5675 t/h	6047 t/h	5825 t/h	5618 t/h	5365 t/h
	66 sec	1.10 min	5897 t/h	5696 t/h	5509 t/h	5278 t/h	5574 t/h	5385 t/h	5208 t/h	4990 t/h
70%	30 sec	0.50 min	7186 t/h	6871 t/h	6582 t/h	N/A	6794 t/h	6495 t/h	6222 t/h	N/A
	42 sec	0.70 min	6521 t/h	6260 t/h	6019 t/h	5726 t/h	6165 t/h	5918 t/h	5690 t/h	5413 t/h
	54 sec	0.90 min	5968 t/h	5749 t/h	5545 t/h	5295 t/h	5642 t/h	5435 t/h	5242 t/h	5006 t/h
	66 sec	1.10 min	5502 t/h	5315 t/h	5141 t/h	4925 t/h	5201 t/h	5025 t/h	4860 t/h	4656 t/h
65%	30 sec	0.50 min	6671 t/h	6378 t/h	6110 t/h	N/A	6306 t/h	6029 t/h	5776 t/h	N/A
	42 sec	0.70 min	6053 t/h	5811 t/h	5587 t/h	5315 t/h	5722 t/h	5493 t/h	5282 t/h	5025 t/h
	54 sec	0.90 min	5540 t/h	5337 t/h	5147 t/h	4915 t/h	5237 t/h	5045 t/h	4866 t/h	4647 t/h
	66 sec	1.10 min	5107 t/h	4934 t/h	4772 t/h	4572 t/h	4828 t/h	4664 t/h	4511 t/h	4322 t/h

**MODEL: 6090 FS ● Bucket Size: 68.0 yd<sup>3</sup> ● Number of Cycles: 4 ● Material Density: 3030 lb/yd<sup>3</sup>**

Overall Mine Efficiency	Bucket Fill Factor		100%				95%					
	Load per Bucket		103.2 tons				98.0 tons					
	Load per Truck		413 tons				392 tons					
Truck Exchange	Cycle Time		28 sec	30 sec	32 sec	34 sec	28 sec	30 sec	32 sec	34 sec		
	0.47 min	0.50 min	0.53 min	0.57 min	0.47 min	0.50 min	0.53 min	0.57 min	0.47 min	0.50 min	0.53 min	0.57 min
83% = maximum 50 min/hour	30 sec	0.50 min	10486 tons/h	10026 tons/h	9604 tons/h	N/A	9960 tons/h	9522 tons/h	9122 tons/h	N/A		
	42 sec	0.70 min	9515 tons/h	9135 tons/h	8783 tons/h	8355 tons/h	9037 tons/h	8676 tons/h	8342 tons/h	7935 tons/h		
	54 sec	0.90 min	8709 tons/h	8389 tons/h	8092 tons/h	7727 tons/h	8271 tons/h	7968 tons/h	7685 tons/h	7339 tons/h		
	66 sec	1.10 min	8028 tons/h	7756 tons/h	7501 tons/h	7186 tons/h	7625 tons/h	7366 tons/h	7124 tons/h	6825 tons/h		
80%	30 sec	0.50 min	10069 tons/h	9627 tons/h	9222 tons/h	N/A	9564 tons/h	9144 tons/h	8759 tons/h	N/A		
	42 sec	0.70 min	9137 tons/h	8771 tons/h	8434 tons/h	8023 tons/h	8678 tons/h	8331 tons/h	8010 tons/h	7620 tons/h		
	54 sec	0.90 min	8363 tons/h	8055 tons/h	7770 tons/h	7419 tons/h	7943 tons/h	7651 tons/h	7380 tons/h	7047 tons/h		
	66 sec	1.10 min	7709 tons/h	7447 tons/h	7203 tons/h	6901 tons/h	7322 tons/h	7073 tons/h	6841 tons/h	6554 tons/h		
75%	30 sec	0.50 min	9437 tons/h	9023 tons/h	8644 tons/h	N/A	8964 tons/h	8570 tons/h	8210 tons/h	N/A		
	42 sec	0.70 min	8564 tons/h	8221 tons/h	7905 tons/h	7519 tons/h	8134 tons/h	7808 tons/h	7508 tons/h	7142 tons/h		
	54 sec	0.90 min	7838 tons/h	7550 tons/h	7282 tons/h	6954 tons/h	7444 tons/h	7171 tons/h	6917 tons/h	6605 tons/h		
	66 sec	1.10 min	7226 tons/h	6980 tons/h	6751 tons/h	6468 tons/h	6863 tons/h	6630 tons/h	6412 tons/h	6143 tons/h		
70%	30 sec	0.50 min	8806 tons/h	8419 tons/h	8065 tons/h	N/A	8364 tons/h	7996 tons/h	7660 tons/h	N/A		
	42 sec	0.70 min	7990 tons/h	7671 tons/h	7376 tons/h	7016 tons/h	7589 tons/h	7286 tons/h	7005 tons/h	6664 tons/h		
	54 sec	0.90 min	7313 tons/h	7045 tons/h	6795 tons/h	6488 tons/h	6946 tons/h	6691 tons/h	6454 tons/h	6163 tons/h		
	66 sec	1.10 min	6742 tons/h	6513 tons/h	6299 tons/h	6035 tons/h	6403 tons/h	6186 tons/h	5983 tons/h	5732 tons/h		
65%	30 sec	0.50 min	8174 tons/h	7815 tons/h	7487 tons/h	N/A	7764 tons/h	7423 tons/h	7111 tons/h	N/A		
	42 sec	0.70 min	7417 tons/h	7121 tons/h	6847 tons/h	6513 tons/h	7045 tons/h	6763 tons/h	6503 tons/h	6186 tons/h		
	54 sec	0.90 min	6789 tons/h	6539 tons/h	6308 tons/h	6023 tons/h	6448 tons/h	6211 tons/h	5991 tons/h	5721 tons/h		
	66 sec	1.10 min	6258 tons/h	6046 tons/h	5847 tons/h	5602 tons/h	5944 tons/h	5742 tons/h	5554 tons/h	5321 tons/h		

Overall Mine Efficiency	Bucket Fill Factor		90%				85%					
	Load per Bucket		92.8 tons				87.7 tons					
	Load per Truck		371 tons				351 tons					
Truck Exchange	Cycle Time		28 sec	30 sec	32 sec	34 sec	28 sec	30 sec	32 sec	34 sec		
	0.47 min	0.50 min	0.53 min	0.57 min	0.47 min	0.50 min	0.53 min	0.57 min	0.47 min	0.50 min	0.53 min	0.57 min
83% = maximum 50 min/hour	30 sec	0.50 min	9433 tons/h	9019 tons/h	8640 tons/h	N/A	8918 tons/h	8526 tons/h	8168 tons/h	N/A		
	42 sec	0.70 min	8560 tons/h	8217 tons/h	7901 tons/h	7516 tons/h	8092 tons/h	7768 tons/h	7469 tons/h	7105 tons/h		
	54 sec	0.90 min	7834 tons/h	7546 tons/h	7279 tons/h	6951 tons/h	7406 tons/h	7134 tons/h	6881 tons/h	6571 tons/h		
	66 sec	1.10 min	7222 tons/h	6977 tons/h	6748 tons/h	6465 tons/h	6828 tons/h	6596 tons/h	6379 tons/h	6111 tons/h		
80%	30 sec	0.50 min	9058 tons/h	8660 tons/h	8296 tons/h	N/A	8563 tons/h	8187 tons/h	7843 tons/h	N/A		
	42 sec	0.70 min	8219 tons/h	7890 tons/h	7587 tons/h	7217 tons/h	7770 tons/h	7459 tons/h	7173 tons/h	6823 tons/h		
	54 sec	0.90 min	7523 tons/h	7246 tons/h	6990 tons/h	6674 tons/h	7112 tons/h	6850 tons/h	6608 tons/h	6310 tons/h		
	66 sec	1.10 min	6935 tons/h	6699 tons/h	6479 tons/h	6208 tons/h	6556 tons/h	6333 tons/h	6125 tons/h	5868 tons/h		
75%	30 sec	0.50 min	8490 tons/h	8117 tons/h	7776 tons/h	N/A	8026 tons/h	7674 tons/h	7351 tons/h	N/A		
	42 sec	0.70 min	7704 tons/h	7395 tons/h	7111 tons/h	6764 tons/h	7283 tons/h	6991 tons/h	6723 tons/h	6395 tons/h		
	54 sec	0.90 min	7051 tons/h	6792 tons/h	6551 tons/h	6256 tons/h	6666 tons/h	6421 tons/h	6193 tons/h	5914 tons/h		
	66 sec	1.10 min	6500 tons/h	6279 tons/h	6073 tons/h	5818 tons/h	6145 tons/h	5936 tons/h	5741 tons/h	5500 tons/h		
70%	30 sec	0.50 min	7921 tons/h	7574 tons/h	7255 tons/h	N/A	7489 tons/h	7160 tons/h	6859 tons/h	N/A		
	42 sec	0.70 min	7188 tons/h	6900 tons/h	6635 tons/h	6311 tons/h	6795 tons/h	6523 tons/h	6273 tons/h	5967 tons/h		
	54 sec	0.90 min	6579 tons/h	6337 tons/h	6113 tons/h	5837 tons/h	6219 tons/h	5991 tons/h	5779 tons/h	5518 tons/h		
	66 sec	1.10 min	6065 tons/h	5859 tons/h	5666 tons/h	5429 tons/h	5734 tons/h	5539 tons/h	5357 tons/h	5132 tons/h		
65%	30 sec	0.50 min	7353 tons/h	7030 tons/h	6735 tons/h	N/A	6951 tons/h	6646 tons/h	6367 tons/h	N/A		
	42 sec	0.70 min	6672 tons/h	6405 tons/h	6159 tons/h	5859 tons/h	6308 tons/h	6056 tons/h	5823 tons/h	5539 tons/h		
	54 sec	0.90 min	6107 tons/h	5883 tons/h	5674 tons/h	5418 tons/h	5773 tons/h	5561 tons/h	5364 tons/h	5122 tons/h		
	66 sec	1.10 min	5630 tons/h	5439 tons/h	5260 tons/h	5039 tons/h	5322 tons/h	5141 tons/h	4973 tons/h	4764 tons/h		

# TELESCOPIC HANDLERS

## CONTENTS

Features . . . . .	17-1
Specifications . . . . .	17-2
Performance Data . . . . .	17-14
Shipping Dimensions . . . . .	17-31
Work Tools . . . . .	17-34
Compatibility . . . . .	17-40

### Features:

- **Intuitive control layout** enables efficient and comfortable operation.
- **Hydraulic system** enables the use of work tools requiring both intermittent and continuous auxiliary hydraulic flows.
- **Range of lift heights and load capacities** from 2500 kg (5500 lb) to 5443 kg (12,000 lb) capacity and 5.6 m (18'4") to 17.3 m (56'9") lift height.
- **Cat® Telehandlers offer extended reach** to easily enable material to be placed over onsite obstacles.
- **Three steering modes and tight turning circles** allow simplified movement onsite and therefore increased productivity.
- **Cat Telehandlers have engine options** which either meet U.S. EPA Tier 4 Final/EU Stage IV/Japan 2014 (Tier 4 Final) emission standards, Tier 4 Interim/EU Stage IIIB/Japan 2011 (Tier 4 Interim) equivalent emission standards, or Tier 3/Stage IIIA/Japan 2006 (Tier 3) equivalent emission standards.

- **Three transmissions options are available on telehandlers.** The TH255 is fitted with a hydrostatic transmission. The TL and TH range are fitted with 4 speed powershift transmissions. The high horsepower TH range is fitted with 6 speed powershift transmissions.
- **Three types of quick couplers are offered on the various telehandler models.** The TH255 is fitted with a universal skid steer loader style coupler enabling the use of many SSL work tools. The TL and TH lines of telehandlers offer hydraulic and manual style IT interface couplers which provide excellent work tool compatibility with older models of telehandlers and other products (for example Backhoe Loaders and Small Wheel Loaders).
- **Three auxiliary hydraulic options** are available: one auxiliary hydraulic service, two auxiliary hydraulic services and continuous hydraulic flow. These options allow maximum work tool utilization.
- **Daily maintenance** consists of only a walkaround inspection, all major components and service points are located at ground level, providing excellent ease of service.

MODEL	TH255C		TH306D		TH306D	
Maximum Lift Height	5.6 m	<b>18'4"</b>	5.8 m	<b>19'0"</b>	5.8 m	<b>19'0"</b>
Maximum Lift Capacity	2500 kg	<b>5500 lb</b>	2800 kg	<b>6172 lb</b>	2800 kg	<b>6172 lb</b>
Operating Weight	5010 kg	<b>11,050 lb</b>	6168 kg	<b>13,598 lb</b>	6168 kg	<b>13,598 lb</b>
Flywheel Power (Gross)						
Standard	55 kW	<b>74 hp</b>	75 kW	<b>100 hp</b>	75 kW	<b>100 hp</b>
Engine Model						
Standard	<b>Deutz TD 2.9L L4 Tier 4 Final<sup>1,2</sup></b>		<b>Deutz 3.6L Tier 4 Final<sup>1</sup></b>		<b>Deutz 3.6L Tier 3 equivalent<sup>2</sup></b>	
Rated Engine RPM	<b>1800</b>		<b>2200</b>		<b>2200</b>	
No. of Cylinders	<b>4</b>		—		—	
Standard Engine						
Bore	92 mm	<b>3.6"</b>	98 mm	<b>3.9"</b>	98 mm	<b>3.9"</b>
Stroke	110 mm	<b>4.3"</b>	120 mm	<b>4.7"</b>	120 mm	<b>4.7"</b>
Displacement	2.9 L	<b>177 in<sup>3</sup></b>	3.6 L	<b>220 in<sup>3</sup></b>	3.6 L	<b>220 in<sup>3</sup></b>
Speeds Forward:						
1st						
2nd						
3rd	Hydrostatic, variable	<b>Hydrostatic, variable</b>	Hydrostatic, two speed	<b>Hydrostatic, two speed</b>	Hydrostatic, two speed	<b>Hydrostatic, two speed</b>
4th	0-29 km/h	<b>0-18 mph</b>	0-32 km/h	<b>0-20 mph</b>	0-32 km/h	<b>0-20 mph</b>
5th						
6th						
Speeds Reverse:						
1st						
2nd	Hydrostatic, variable	<b>Hydrostatic, variable</b>	Hydrostatic, two speed	<b>Hydrostatic, two speed</b>	Hydrostatic, two speed	<b>Hydrostatic, two speed</b>
3rd	0-29 km/h	<b>0-18 mph</b>	0-32 km/h	<b>0-20 mph</b>	0-32 km/h	<b>0-20 mph</b>
Turning Circle Radius:						
Over Tires	3200 mm	<b>126"</b>	3700 mm	<b>12.1'</b>	3700 mm	<b>12.1'</b>
Over Forks	4305 mm	<b>169"</b>	4400 mm	<b>14.4'</b>	4400 mm	<b>14.4'</b>
Standard Tires	<b>12.00 x 16.5</b>		<b>405/70 T20 MPT01 AIR</b>		<b>405/70 T20 MPT01 AIR</b>	
Service Refill Capacity:						
Fuel Tank @ 90% Fill	91 L	<b>24 U.S. gal</b>	104 L	<b>27.4 U.S. gal</b>	104 L	<b>27.4 U.S. gal</b>
Hydraulic System	98 L	<b>26 U.S. gal</b>	120 L	<b>31.7 U.S. gal</b>	120 L	<b>31.7 U.S. gal</b>

<sup>1</sup> Meets Tier 4 Final/Stage IV/Japan 2014 (Tier 4 Final) emission standards.

<sup>2</sup> Meets Tier 3/Stage IIIA/Japan 2006 (Tier 3) equivalent emission standards.

MODEL	TH336C		TH336C		TH337C	
Maximum Lift Height	6.1 m	20'0"	6.1 m	20'0"	7.3 m	24'0"
Maximum Lift Capacity	3300 kg	7275 lb	3300 kg	7275 lb	3300 kg	7275 lb
Operating Weight	6820 kg	15,035 lb	6820 kg	15,035 lb	7045 kg	15,531 lb
Flywheel Power (Gross)						
Standard	74.5 kW	100 hp	74.5 kW	101 hp	74.5 kW	100 hp
Option 1	92.6 kW	124 hp	93.1 kW	125 hp	92.6 kW	124 hp
Option 2	106 kW	142 hp	—	—	106 kW	142 hp
Engine Model						
Standard	C3.4B Tier 4 Final <sup>1</sup>		C4.4 Tier 3 equivalent <sup>2</sup>		C3.4B Tier 4 Final <sup>1</sup>	
Option 1	C4.4 ACERT™ Tier 4 Final <sup>1</sup>		C4.4 Tier 3 equivalent <sup>2</sup>		C4.4 ACERT Tier 4 Final <sup>1</sup>	
Option 2	C4.4 ACERT Tier 4 Final <sup>1</sup>				C4.4 ACERT Tier 4 Final <sup>1</sup>	
Rated Engine RPM	2200		2400		2200	
No. of Cylinders	4		4		4	
Standard Engine						
Bore	99 mm	3.9"	105 mm	4.13"	99 mm	3.9"
Stroke	110 mm	4.33"	127 mm	4.99"	110 mm	4.33"
Displacement	3.4 L	207.5 in <sup>3</sup>	4.4 L	269 in <sup>3</sup>	3.4 L	207.5 in <sup>3</sup>
Engine Options 1 and 2						
Bore	105 mm	4.13"	105 mm	4.13"	105 mm	4.13"
Stroke	127 mm	4.99"	127 mm	4.99"	127 mm	4.99"
Displacement	4.4 L	269 in <sup>3</sup>	4.4 L	269 in <sup>3</sup>	4.4 L	269 in <sup>3</sup>
Speeds Forward:	km/h	mph	km/h	mph	km/h	mph
1st	6.7	4.2	6.7	4.2	6.7	4.2
2nd	10.0	6.2	10.0	6.2	10.0	6.2
3rd	12.9	8.0	12.9	8.0	12.9	8.0
4th	19.4	12.1	19.4	12.1	19.4	12.1
5th	29.7	18.5	29.7	18.5	29.7	18.5
6th	40.0	24.9	40.0	24.9	40.0	24.9
Speeds Reverse:	km/h	mph	km/h	mph	km/h	mph
1st	6.7	4.2	6.7	4.2	6.7	4.2
2nd	12.9	8.0	12.9	8.0	12.9	8.0
3rd	29.7	18.5	29.7	18.5	29.7	18.5
Turning Circle Radius:						
Over Tires	3750 mm	12.3'	3820 mm	12.5'	3820 mm	12.5'
Over Forks	4750 mm	15.6'	4900 mm	16.0'	4900 mm	16.0'
Standard Tires	15.5/80-24 16PR		15.5/80-24 16PR		15.5/80-24 16PR	
Service Refill Capacity:						
Fuel Tank @ 90% Fill	150 L	39.6 U.S. gal	150 L	39.6 U.S. gal	150 L	39.6 U.S. gal
Hydraulic System	90 L	23.7 U.S. gal	90 L	23.7 U.S. gal	90 L	23.7 U.S. gal

<sup>1</sup> Meets Tier 4 Final/Stage IV/Japan 2014 (Tier 4 Final) emission standards.

<sup>2</sup> Meets Tier 3/Stage IIIA/Japan 2006 (Tier 3) equivalent emission standards.



MODEL	TH337C		TH406C		TH406C	
Maximum Lift Height	7.3 m	<b>24'0"</b>	6.1 m	<b>20'0"</b>	6.1 m	<b>20'0"</b>
Maximum Lift Capacity	3300 kg	<b>7275 lb</b>	3700 kg	<b>8157 lb</b>	3700 kg	<b>8157 lb</b>
Operating Weight	7045 kg	<b>15,531 lb</b>	7736 kg	<b>17,054 lb</b>	7736 kg	<b>17,054 lb</b>
Flywheel Power (Gross)						
Standard	74.5 kW	<b>101 hp</b>	74.5 kW	<b>100 hp</b>	74.5 kW	<b>101 hp</b>
Option 1	93.1 kW	<b>125 hp</b>	92.6 kW	<b>124 hp</b>	93.1 kW	<b>125 hp</b>
Option 2	—		106 kW	<b>142 hp</b>	—	
Engine Model						
Standard	<b>C4.4</b>		<b>C3.4B</b>		<b>C4.4</b>	
	<b>Tier 3 equivalent<sup>2</sup></b>		<b>Tier 4 Final<sup>1</sup></b>		<b>Tier 3 equivalent<sup>2</sup></b>	
Option 1	<b>C4.4</b>		<b>C4.4 ACERT</b>		<b>C4.4</b>	
	<b>Tier 3 equivalent<sup>2</sup></b>		<b>Tier 4 Final<sup>1</sup></b>		<b>Tier 3 equivalent<sup>2</sup></b>	
Option 2	—		<b>C4.4 ACERT</b>		—	
			<b>Tier 4 Final<sup>1</sup></b>			
Rated Engine RPM	<b>2400</b>		<b>2200</b>		<b>2400</b>	
No. of Cylinders	<b>4</b>		<b>4</b>		<b>4</b>	
Standard Engine						
Bore	105 mm	<b>4.13"</b>	99 mm	<b>3.9"</b>	105 mm	<b>4.13"</b>
Stroke	127 mm	<b>4.99"</b>	110 mm	<b>4.33"</b>	127 mm	<b>4.99"</b>
Displacement	4.4 L	<b>269 in<sup>3</sup></b>	3.4 L	<b>207.5 in<sup>3</sup></b>	4.4 L	<b>269 in<sup>3</sup></b>
Engine Options 1 and 2						
Bore	105 mm	<b>4.13"</b>	105 mm	<b>4.13"</b>	105 mm	<b>4.13"</b>
Stroke	127 mm	<b>4.99"</b>	127 mm	<b>4.99"</b>	127 mm	<b>4.99"</b>
Displacement	4.4 L	<b>269 in<sup>3</sup></b>	4.4 L	<b>269 in<sup>3</sup></b>	4.4 L	<b>269 in<sup>3</sup></b>
Speeds Forward:	<b>km/h</b>	<b>mph</b>	<b>km/h</b>	<b>mph</b>	<b>km/h</b>	<b>mph</b>
1st	6.7	<b>4.2</b>	6.7	<b>4.2</b>	6.7	<b>4.2</b>
2nd	10.0	<b>6.2</b>	10.0	<b>6.2</b>	10.0	<b>6.2</b>
3rd	12.9	<b>8.0</b>	12.9	<b>8.0</b>	12.9	<b>8.0</b>
4th	19.4	<b>12.1</b>	19.4	<b>12.1</b>	19.4	<b>12.1</b>
5th	29.7	<b>18.5</b>	29.7	<b>18.5</b>	29.7	<b>18.5</b>
6th	40.0	<b>24.9</b>	40.0	<b>24.9</b>	40.0	<b>24.9</b>
Speeds Reverse:	<b>km/h</b>	<b>mph</b>	<b>km/h</b>	<b>mph</b>	<b>km/h</b>	<b>mph</b>
1st	6.7	<b>4.2</b>	6.7	<b>4.2</b>	6.7	<b>4.2</b>
2nd	12.9	<b>8.0</b>	12.9	<b>8.0</b>	12.9	<b>8.0</b>
3rd	29.7	<b>18.5</b>	29.7	<b>18.5</b>	29.7	<b>18.5</b>
Turning Circle Radius:						
Over Tires	3820 mm	<b>12.5'</b>	3750 mm	<b>12.3'</b>	3820 mm	<b>12.5'</b>
Over Forks	4900 mm	<b>16.0'</b>	4750 mm	<b>15.5'</b>	4900 mm	<b>16.0'</b>
Standard Tires	<b>15.5/80-24 16PR</b>		<b>15.5/80-24 16PR</b>		<b>15.5/80-24 16PR</b>	
Service Refill Capacity:						
Fuel Tank @ 90% Fill	150 L	<b>39.6 U.S. gal</b>	150 L	<b>39.6 U.S. gal</b>	150 L	<b>39.6 U.S. gal</b>
Hydraulic System	90 L	<b>23.7 U.S. gal</b>	90 L	<b>23.7 U.S. gal</b>	90 L	<b>23.7 U.S. gal</b>

<sup>1</sup> Meets Tier 4 Final/Stage IV/Japan 2014 (Tier 4 Final) emission standards.

<sup>2</sup> Meets Tier 3/Stage IIIA/Japan 2006 (Tier 3) equivalent emission standards.

MODEL	TH407C		TH407C		TH3510D	
Maximum Lift Height	7.3 m	<b>24'0"</b>	7.3 m	<b>24'0"</b>	9.8 m	<b>32.1'</b>
Maximum Lift Capacity	3700 kg	<b>8157 lb</b>	3700 kg	<b>8157 lb</b>	3500 kg	<b>7716 lb</b>
Operating Weight	7941 kg	<b>17,506 lb</b>	7941 kg	<b>17,506 lb</b>	8990 kg	<b>19,819 lb</b>
Flywheel Power (Gross)						
Standard	74.5 kW	<b>100 hp</b>	74.5 kW	<b>101 hp</b>	75 kW	<b>100 hp</b>
Option 1	92.6 kW	<b>124 hp</b>	93.1 kW	<b>125 hp</b>	93 kW	<b>124 hp</b>
Option 2	106 kW	<b>142 hp</b>	—		106 kW	<b>142 hp</b>
Engine Model						
Standard	<b>C3.4B</b> Tier 4 Interim equivalent <sup>2</sup>		<b>C4.4</b> Tier 3 equivalent <sup>3</sup>		<b>C3.4B</b> Tier 4 Final <sup>1</sup>	
Option 1	<b>C4.4 ACERT</b> Tier 4 Interim equivalent <sup>2</sup>		<b>C4.4</b> Tier 3 equivalent <sup>3</sup>		<b>C4.4 ACERT</b> Tier 4 Final <sup>1</sup>	
Option 2	<b>C4.4 ACERT</b> Tier 4 Interim equivalent <sup>2</sup>		—		<b>C4.4 ACERT</b> Tier 4 Final <sup>1</sup>	
Rated Engine RPM	<b>2200</b>		<b>2400</b>		<b>2200</b>	
No. of Cylinders	<b>4</b>		<b>4</b>		<b>6</b>	
Standard Engine						
Bore	99 mm	<b>3.9"</b>	105 mm	<b>4.13"</b>	99 mm	<b>3.9"</b>
Stroke	110 mm	<b>4.33"</b>	127 mm	<b>4.99"</b>	110 mm	<b>4.33"</b>
Displacement	3.4 L	<b>207.5 in<sup>3</sup></b>	4.4 L	<b>269 in<sup>3</sup></b>	3.4 L	<b>207 in<sup>3</sup></b>
Engine Options 1 and 2						
Bore	105 mm	<b>4.13"</b>	105 mm	<b>4.13"</b>	105 mm	<b>4.13"</b>
Stroke	127 mm	<b>4.99"</b>	127 mm	<b>4.99"</b>	127 mm	<b>4.99"</b>
Displacement	4.4 L	<b>269 in<sup>3</sup></b>	4.4 L	<b>269 in<sup>3</sup></b>	4.4 L	<b>269 in<sup>3</sup></b>
Speeds Forward:	<b>km/h</b>	<b>mph</b>	<b>km/h</b>	<b>mph</b>	<b>km/h</b>	<b>mph</b>
1st	6.7	<b>4.2</b>	6.7	<b>4.2</b>	5.79	<b>3.60</b>
2nd	10.0	<b>6.2</b>	10.0	<b>6.2</b>	8.64	<b>5.36</b>
3rd	12.9	<b>8.0</b>	12.9	<b>8.0</b>	11.25	<b>6.99</b>
4th	19.4	<b>12.1</b>	19.4	<b>12.1</b>	16.65	<b>10.34</b>
5th	29.7	<b>18.5</b>	29.7	<b>18.5</b>	25.36	<b>15.75</b>
6th	40.0	<b>24.9</b>	40.0	<b>24.9</b>	36.36	<b>22.59</b>
Speeds Reverse:	<b>km/h</b>	<b>mph</b>	<b>km/h</b>	<b>mph</b>	<b>km/h</b>	<b>mph</b>
1st	6.7	<b>4.2</b>	6.7	<b>4.2</b>	5.79	<b>3.60</b>
2nd	12.9	<b>8.0</b>	12.9	<b>8.0</b>	11.25	<b>6.99</b>
3rd	29.7	<b>18.5</b>	29.7	<b>18.5</b>	25.36	<b>15.75</b>
Turning Circle Radius:						
Over Tires	3820 mm	<b>12.5'</b>	3820 mm	<b>12.5'</b>	3847 mm	<b>12.6'</b>
Over Forks	4900 mm	<b>16.0'</b>	4900 mm	<b>16.0'</b>	4875 mm	<b>16.0'</b>
Standard Tires	<b>15.5/80-24 16PR</b>		<b>15.5/80-24 16PR</b>		<b>15.5/80-24 16PR MITAS</b>	
Service Refill Capacity:						
Fuel Tank @ 90% Fill	150 L	<b>39.6 U.S. gal</b>	150 L	<b>39.6 U.S. gal</b>	148 L	<b>39 U.S. gal</b>
Hydraulic System	90 L	<b>23.7 U.S. gal</b>	90 L	<b>23.7 U.S. gal</b>	120 L	<b>31.7 U.S. gal</b>

<sup>1</sup> Meets Tier 4 Final/Stage IV/Japan 2014 (Tier 4 Final) emission standards.

<sup>2</sup> Meets Tier 4 Interim/Stage IIIB/Japan 2011 (Tier 4 Interim) equivalent emission standards.

<sup>3</sup> Meets Tier 3/Stage IIIA/Japan 2006 (Tier 3) equivalent emission standards.

MODEL	TH3510D		TH414C		TH414C	
Maximum Lift Height	9.8 m	<b>32.1'</b>	13.7 m	<b>45'0"</b>	13.7 m	<b>45'0"</b>
Maximum Lift Capacity	3500 kg	<b>7716 lb</b>	3700 kg	<b>8157 lb</b>	3700 kg	<b>8157 lb</b>
Operating Weight	9006 kg	<b>19,854 lb</b>	9360 kg	<b>20,635 lb</b>	9360 kg	<b>20,635 lb</b>
Flywheel Power (Gross)						
Standard	75 kW	<b>100 hp</b>	74.5 kW	<b>100 hp</b>	74.5 kW	<b>101 hp</b>
Engine Model						
Standard	<b>4.4 ACERT Tier 3 equivalent<sup>2</sup></b>		<b>C3.4B Tier 4 Interim equivalent<sup>1</sup></b>		<b>C4.4 Tier 3 equivalent<sup>2</sup></b>	
Rated Engine RPM	<b>2200</b>		<b>2400</b>		<b>2400</b>	
No. of Cylinders	<b>6</b>		<b>4</b>		<b>4</b>	
Standard Engine						
Bore	105 mm	<b>4.13"</b>	99 mm	<b>3.9"</b>	105 mm	<b>4.13"</b>
Stroke	127 mm	<b>4.99"</b>	110 mm	<b>4.33"</b>	127 mm	<b>4.99"</b>
Displacement	4.4 L	<b>269 in<sup>3</sup></b>	3.4 L	<b>207.5 in<sup>3</sup></b>	4.4 L	<b>269 in<sup>3</sup></b>
Speeds Forward:	<b>km/h</b>	<b>mph</b>	<b>km/h</b>	<b>mph</b>	<b>km/h</b>	<b>mph</b>
1st	5.79	<b>3.60</b>	7.0	<b>4.3</b>	7.0	<b>4.3</b>
2nd	8.64	<b>5.36</b>	12.0	<b>7.4</b>	12.0	<b>7.4</b>
3rd	11.25	<b>6.99</b>	21.0	<b>13.0</b>	21.0	<b>13.0</b>
4th	16.65	<b>10.34</b>	32.0	<b>19.8</b>	32.0	<b>19.8</b>
5th	25.36	<b>15.75</b>		—		—
6th	36.36	<b>22.59</b>		—		—
Speeds Reverse:	<b>km/h</b>	<b>mph</b>	<b>km/h</b>	<b>mph</b>	<b>km/h</b>	<b>mph</b>
1st	5.79	<b>3.60</b>	7.0	<b>4.3</b>	7.0	<b>4.3</b>
2nd	11.25	<b>6.99</b>	12.0	<b>7.4</b>	12.0	<b>7.4</b>
3rd	25.36	<b>15.75</b>	21.0	<b>13.0</b>	21.0	<b>13.0</b>
Turning Circle Radius:						
Over Tires	3847 mm	<b>12.6'</b>	3805 mm	<b>12.4'</b>	3920 mm	<b>12.8'</b>
Over Forks	4875 mm	<b>16.0'</b>	5640 mm	<b>18.5'</b>	5650 mm	<b>18.5'</b>
Standard Tires	<b>15.5/80-24 16PR MITAS</b>		<b>14.00-24 16 PRTG-02</b>		<b>14.00-24 16 PRTG-02</b>	
Service Refill Capacity:						
Fuel Tank @ 90% Fill	148 L	<b>39 U.S. gal</b>	150 L	<b>39.6 U.S. gal</b>	150 L	<b>39.6 U.S. gal</b>
Hydraulic System	120 L	<b>31.7 U.S. gal</b>	90 L	<b>23.7 U.S. gal</b>	90 L	<b>23.7 U.S. gal</b>

<sup>1</sup> Meets Tier 4 Interim/Stage IIIB/Japan 2011 (Tier 4 Interim) equivalent emission standards.

<sup>2</sup> Meets Tier 3/Stage IIIA/Japan 2006 (Tier 3) equivalent emission standards.

MODEL	TH417C		TH417C		TH514C	
Maximum Lift Height	17.3 m	<b>56'9"</b>	17.3 m	<b>56'9"</b>	13.7 m	<b>45'0"</b>
Maximum Lift Capacity	4000 kg	<b>8818 lb</b>	4000 kg	<b>8818 lb</b>	4999 kg	<b>11,020 lb</b>
Operating Weight	11 800 kg	<b>26,014 lb</b>	11 800 kg	<b>26,014 lb</b>	10 760 kg	<b>23,721 lb</b>
Flywheel Power (Gross)						
Standard	74.5 kW	<b>101 hp</b>	74.5 kW	<b>101 hp</b>	74.5 kW	<b>100 hp</b>
Engine Model						
Standard	<b>C3.4B</b>		<b>C4.4</b>		<b>C3.4B</b>	
	<b>Tier 4 Interim equivalent<sup>1</sup></b>		<b>Tier 3 equivalent<sup>2</sup></b>		<b>Tier 4 Interim equivalent<sup>1</sup></b>	
Rated Engine RPM	<b>2400</b>		<b>2400</b>		<b>2400</b>	
No. of Cylinders	<b>4</b>		<b>4</b>		<b>4</b>	
Standard Engine						
Bore	99 mm	<b>3.9"</b>	105 mm	<b>4.13"</b>	99 mm	<b>3.9"</b>
Stroke	110 mm	<b>4.33"</b>	127 mm	<b>4.99"</b>	110 mm	<b>4.33"</b>
Displacement	3.4 L	<b>207.5 in<sup>3</sup></b>	4.4 L	<b>269 in<sup>3</sup></b>	3.4 L	<b>207.5 in<sup>3</sup></b>
Speeds Forward:	<b>km/h</b>	<b>mph</b>	<b>km/h</b>	<b>mph</b>	<b>km/h</b>	<b>mph</b>
1st	7.0	<b>4.3</b>	7.0	<b>4.3</b>	7.0	<b>4.3</b>
2nd	12.0	<b>7.4</b>	12.0	<b>7.4</b>	12.0	<b>7.4</b>
3rd	21.0	<b>13.0</b>	21.0	<b>13.0</b>	21.0	<b>13.0</b>
4th	32.0	<b>19.8</b>	32.0	<b>19.8</b>	32.0	<b>19.8</b>
Speeds Reverse:	<b>km/h</b>	<b>mph</b>	<b>km/h</b>	<b>mph</b>	<b>km/h</b>	<b>mph</b>
1st	7.0	<b>4.3</b>	7.0	<b>4.3</b>	7.0	<b>4.3</b>
2nd	12.0	<b>7.4</b>	12.0	<b>7.4</b>	12.0	<b>7.4</b>
3rd	21.0	<b>13.0</b>	21.0	<b>13.0</b>	21.0	<b>13.0</b>
Turning Circle Radius:						
Over Tires	3920 mm	<b>12.8'</b>	3920 mm	<b>12.8'</b>	3920 mm	<b>12.8'</b>
Over Forks	5650 mm	<b>18.5'</b>	5650 mm	<b>18.5'</b>	5570 mm	<b>18.2'</b>
Standard Tires	<b>14.00-24 16 PRTG-02</b>		<b>14.00-24 16 PRTG-02</b>		<b>14.00-24 16 PRTG-02</b>	
Service Refill Capacity:						
Fuel Tank @ 90% Fill	150 L	<b>39.6 U.S. gal</b>	150 L	<b>39.6 U.S. gal</b>	150 L	<b>39.6 U.S. gal</b>
Hydraulic System	90 L	<b>23.7 U.S. gal</b>	90 L	<b>23.7 U.S. gal</b>	90 L	<b>23.7 U.S. gal</b>

<sup>1</sup> Meets Tier 4 Interim/Stage IIIB/Japan 2011 (Tier 4 Interim) equivalent emission standards.

<sup>2</sup> Meets Tier 3/Stage IIIA/Japan 2006 (Tier 3) equivalent emission standards.

MODEL	TH514C		TL642C		TL642C	
Maximum Lift Height	13.7 m	<b>45'0"</b>	12.8 m	<b>42'0"</b>	12.8 m	<b>42'0"</b>
Maximum Lift Capacity	4999 kg	<b>11,020 lb</b>	2948 kg	<b>6500 lb</b>	2948 kg	<b>6500 lb</b>
Operating Weight	10 760 kg	<b>23,721 lb</b>	9909 kg	<b>21,845 lb</b>	9999 kg	<b>22,045 lb</b>
Flywheel Power (Gross)						
Standard	74.5 kW	<b>101 hp</b>	75 kW	<b>100.6 hp</b>	74.5 kW	<b>101 hp</b>
Engine Model						
Standard	<b>C4.4</b>		<b>C3.4B</b>		<b>C4.4</b>	
	<b>Tier 3 equivalent<sup>2</sup></b>		<b>Tier 4 Interim equivalent<sup>1</sup></b>		<b>Tier 3 equivalent<sup>2</sup></b>	
Rated Engine RPM	<b>2400</b>		<b>2200</b>		<b>2400</b>	
No. of Cylinders	<b>4</b>		<b>4</b>		<b>4</b>	
Standard Engine						
Bore	105 mm	<b>4.13"</b>	99 mm	<b>3.9"</b>	105 mm	<b>4.13"</b>
Stroke	127 mm	<b>4.99"</b>	110 mm	<b>4.3"</b>	127 mm	<b>4.99"</b>
Displacement	4.4 L	<b>269 in<sup>3</sup></b>	3.4 L	<b>207.5 in<sup>3</sup></b>	4.4 L	<b>269 in<sup>3</sup></b>
Speeds Forward:	<b>km/h</b>	<b>mph</b>	<b>km/h</b>	<b>mph</b>	<b>km/h</b>	<b>mph</b>
1st	7.0	<b>4.3</b>	5.6	<b>3.5</b>	5.7	<b>3.6</b>
2nd	12.0	<b>7.4</b>	11.1	<b>6.9</b>	11.1	<b>6.9</b>
3rd	21.0	<b>13.0</b>	25.1	<b>15.6</b>	25.9	<b>16.1</b>
4th	32.0	<b>19.8</b>	32.9	<b>20.5</b>	35.4	<b>22.0</b>
Speeds Reverse:	<b>km/h</b>	<b>mph</b>	<b>km/h</b>	<b>mph</b>	<b>km/h</b>	<b>mph</b>
1st	7.0	<b>4.3</b>	5.6	<b>3.5</b>	5.7	<b>3.6</b>
2nd	12.0	<b>7.4</b>	11.2	<b>7.0</b>	11.1	<b>6.9</b>
3rd	21.0	<b>13.0</b>	25.2	<b>15.7</b>	26.0	<b>16.2</b>
Turning Circle Radius:						
Over Tires	3920 mm	<b>12.8'</b>	3588 mm	<b>11.7'</b>	3588 mm	<b>11.7'</b>
Over Forks	5650 mm	<b>18.5'</b>	4633 mm	<b>15.2'</b>	4633 mm	<b>15.2'</b>
Standard Tires	<b>14.00-24 16 PRTG-02</b>		<b>370/75-28 Duraforce MT</b>		<b>370/75-28 Duraforce MT</b>	
Service Refill Capacity:						
Fuel Tank @ 90% Fill	150 L	<b>39.6 U.S. gal</b>	144 L	<b>38 U.S. gal</b>	144 L	<b>38 U.S. gal</b>
Hydraulic System	90 L	<b>23.7 U.S. gal</b>	144 L	<b>38 U.S. gal</b>	144 L	<b>38 U.S. gal</b>

<sup>1</sup> Meets Tier 4 Interim/Stage IIIB/Japan 2011 (Tier 4 Interim) equivalent emission standards.

<sup>2</sup> Meets Tier 3/Stage IIIA/Japan 2006 (Tier 3) equivalent emission standards.

MODEL	TL943C		TL943C		TL1055C	
Maximum Lift Height	13.1 m	<b>43'0"</b>	13.1 m	<b>43.0'</b>	16.8 m	<b>55.1'</b>
Maximum Lift Capacity	4082 kg	<b>9000 lb</b>	4082 kg	<b>9000 lb</b>	4536 kg	<b>10,000 lb</b>
Operating Weight	12 304 kg	<b>27,125 lb</b>	12 304 kg	<b>27,125 lb</b>	15 495 kg	<b>34,160 lb</b>
Flywheel Power (Gross)						
Standard	83 kW	<b>111.3 hp</b>	82.1 kW	<b>110.1 hp</b>	106 kW	<b>142 hp</b>
Engine Model						
Standard	<b>C3.4B</b>		<b>C4.4</b>		<b>C4.4 ACERT</b>	
	<b>Tier 4 Interim equivalent<sup>1</sup></b>		<b>Tier 3 equivalent<sup>2</sup></b>		<b>Tier 4 Interim equivalent<sup>1</sup></b>	
Rated Engine RPM	<b>2200</b>		<b>2400</b>		<b>2200</b>	
No. of Cylinders	<b>4</b>		<b>4</b>		<b>4</b>	
Standard Engine						
Bore	99 mm	<b>3.9"</b>	105 mm	<b>4.13"</b>	105 mm	<b>4.13"</b>
Stroke	110 mm	<b>4.3"</b>	127 mm	<b>4.99"</b>	127 mm	<b>4.99"</b>
Displacement	3.4 L	<b>207.5 in<sup>3</sup></b>	4.4 L	<b>269 in<sup>3</sup></b>	4.4 L	<b>269 in<sup>3</sup></b>
Speeds Forward:	<b>km/h</b>	<b>mph</b>	<b>km/h</b>	<b>mph</b>	<b>km/h</b>	<b>mph</b>
1st	5.4	<b>3.4</b>	5.4	<b>3.4</b>	5.3	<b>3.3</b>
2nd	10.4	<b>6.5</b>	10.4	<b>6.5</b>	10.2	<b>6.4</b>
3rd	23.8	<b>14.8</b>	23.8	<b>14.8</b>	23.4	<b>14.6</b>
4th	32.6	<b>20.3</b>	32.6	<b>20.3</b>	32.8	<b>20.4</b>
Speeds Reverse:	<b>km/h</b>	<b>mph</b>	<b>km/h</b>	<b>mph</b>	<b>km/h</b>	<b>mph</b>
1st	5.4	<b>3.4</b>	5.4	<b>3.4</b>	5.3	<b>3.3</b>
2nd	10.6	<b>6.6</b>	10.6	<b>6.6</b>	10.2	<b>6.4</b>
3rd	23.1	<b>14.4</b>	23.1	<b>14.4</b>	23.3	<b>14.5</b>
Turning Circle Radius:						
Over Tires	3658 mm	<b>12.0'</b>	3658 mm	<b>12.0'</b>	3962 mm	<b>12.9'</b>
Over Forks	5197 mm	<b>17.0'</b>	5197 mm	<b>17.0'</b>	4267 mm	<b>13.9'</b>
Standard Tires	<b>370/75-28 Duraforce MT</b>		<b>370/75-28 Duraforce MT</b>		<b>400/75-28 Duraforce MT</b>	
Service Refill Capacity:						
Fuel Tank @ 90% Fill	144 L	<b>38 U.S. gal</b>	144 L	<b>38 U.S. gal</b>	144 L	<b>38 U.S. gal</b>
Hydraulic System	178 L	<b>47 U.S. gal</b>	178 L	<b>47 U.S. gal</b>	238 L	<b>63 U.S. gal</b>

<sup>1</sup> Meets Tier 4 Interim/Stage IIIB/Japan 2011 (Tier 4 Interim) equivalent emission standards.

<sup>2</sup> Meets Tier 3/Stage IIIA/Japan 2006 (Tier 3) equivalent emission standards.

MODEL	TL1055C		TL1255C		TL1255C	
Maximum Lift Height	16.8 m	<b>55.1'</b>	16.6 m	<b>54'5"</b>	16.6 m	<b>54'5"</b>
Maximum Lift Capacity	4536 kg	<b>10,000 lb</b>	5443 kg	<b>12,000 lb</b>	5443 kg	<b>12,000 lb</b>
Operating Weight	15 468 kg	<b>34,100 lb</b>	16 267 kg	<b>35,860 lb</b>	16 211 kg	<b>35,740 lb</b>
Flywheel Power (Gross)						
Standard	106 kW	<b>142 hp</b>	106 kW	<b>142 hp</b>	106 kW	<b>142 hp</b>
Engine Model						
Standard	<b>C4.4</b>		<b>C4.4 ACERT</b>		<b>C4.4</b>	
	<b>Tier 3 equivalent<sup>2</sup></b>		<b>Tier 4 Interim equivalent<sup>1</sup></b>		<b>Tier 3 equivalent<sup>2</sup></b>	
Rated Engine RPM	<b>2400</b>		<b>2200</b>		<b>2400</b>	
No. of Cylinders	<b>4</b>		<b>4</b>		<b>4</b>	
Standard Engine						
Bore	105 mm	<b>4.13"</b>	105 mm	<b>4.13"</b>	105 mm	<b>4.13"</b>
Stroke	127 mm	<b>4.99"</b>	127 mm	<b>4.99"</b>	127 mm	<b>4.99"</b>
Displacement	4.4 L	<b>269 in<sup>3</sup></b>	4.4 L	<b>269 in<sup>3</sup></b>	4.4 L	<b>269 in<sup>3</sup></b>
Speeds Forward:	<b>km/h</b>	<b>mph</b>	<b>km/h</b>	<b>mph</b>	<b>km/h</b>	<b>mph</b>
1st	5.3	<b>3.3</b>	5.3	<b>3.3</b>	5.3	<b>3.3</b>
2nd	10.1	<b>6.3</b>	10.2	<b>6.4</b>	10.1	<b>6.3</b>
3rd	22	<b>13.7</b>	23.4	<b>14.6</b>	22	<b>13.7</b>
4th	29.4	<b>18.3</b>	32.8	<b>20.4</b>	29.4	<b>18.3</b>
Speeds Reverse:	<b>km/h</b>	<b>mph</b>	<b>km/h</b>	<b>mph</b>	<b>km/h</b>	<b>mph</b>
1st	5.3	<b>3.3</b>	5.3	<b>3.3</b>	5.3	<b>3.3</b>
2nd	10.1	<b>6.3</b>	10.2	<b>6.4</b>	10.1	<b>6.3</b>
3rd	20.9	<b>13.0</b>	23.3	<b>14.5</b>	20.9	<b>13.0</b>
Turning Circle Radius:						
Over Tires	3962 mm	<b>12.9'</b>	3962 mm	<b>12.9'</b>	3962 mm	<b>12.9'</b>
Over Forks	4267 mm	<b>13.9'</b>	4267 mm	<b>13.9'</b>	4267 mm	<b>13.9'</b>
Standard Tires	<b>400/75-28 Duraforce MT</b>		<b>400/75-28 Duraforce MT</b>		<b>400/75-28 Duraforce MT</b>	
Service Refill Capacity:						
Fuel Tank @ 90% Fill	144 L	<b>38 U.S. gal</b>	144 L	<b>38 U.S. gal</b>	144 L	<b>38 U.S. gal</b>
Hydraulic System	238 L	<b>63 U.S. gal</b>	238 L	<b>63 U.S. gal</b>	238 L	<b>63 U.S. gal</b>

<sup>1</sup> Meets Tier 4 Interim/Stage IIIB/Japan 2011 (Tier 4 Interim) equivalent emission standards.

<sup>2</sup> Meets Tier 3/Stage IIIA/Japan 2006 (Tier 3) equivalent emission standards.

MODEL	TL642D		TL642D		TL943D	
Maximum Lift Height	12.8 m	<b>41'11"</b>	12.8 m	<b>41'11"</b>	13.1 m	<b>43'1"</b>
Maximum Lift Capacity	2948 kg	<b>6500 lb</b>	2948 kg	<b>6500 lb</b>	4082 kg	<b>9000 lb</b>
Operating Weight	9860 kg	<b>21,738 lb</b>	9860 kg	<b>21,738 lb</b>	11 550 kg	<b>25,463 lb</b>
Flywheel Power (Gross)						
Standard	75 kW	<b>100 hp</b>	75 kW	<b>100 hp</b>	83 kW	<b>111 hp</b>
Engine Model						
Standard	<b>C3.4B Tier 4 Final<sup>1</sup></b>		<b>C4.4 Tier 3 equivalent<sup>2</sup></b>		<b>C3.4B Tier 4 Final<sup>1</sup></b>	
Rated Engine RPM	<b>2200</b>		<b>2200</b>		<b>2200</b>	
No. of Cylinders	<b>4</b>		<b>4</b>		<b>4</b>	
Standard Engine						
Displacement	3.4 L	<b>207 in<sup>3</sup></b>	4.4 L	<b>269 in<sup>3</sup></b>	3.4 L	<b>207 in<sup>3</sup></b>
Speeds Forward	32 km/h	<b>20 mph</b>	32 km/h	<b>20 mph</b>	29.9 km/h	<b>19 mph</b>
Speeds Reverse	32 km/h	<b>20 mph</b>	32 km/h	<b>20 mph</b>	29.9 km/h	<b>19 mph</b>
Turning Circle Radius:						
OverTires	3660 mm	<b>12.0'</b>	3660 mm	<b>12.0'</b>	3660 mm	<b>12.0'</b>
Standard Tires	<b>370/75-28 Air Duraforce</b>		<b>370/75-28 Air Duraforce</b>		<b>370/75-28 Air Duraforce</b>	
Service Refill Capacity:						
Fuel Tank @ 90% Fill	145 L	<b>38.3 U.S. gal</b>	145 L	<b>38.3 U.S. gal</b>	145 L	<b>38.3 U.S. gal</b>
Hydraulic System	151.5 L	<b>40 U.S. gal</b>	151.5 L	<b>40 U.S. gal</b>	177 L	<b>47 U.S. gal</b>

<sup>1</sup> Meets Tier 4 Final/Stage IV/Japan 2014 (Tier 4 Final) emission standards.

<sup>2</sup> Meets Tier 3/Stage IIIA/Japan 2006 (Tier 3) equivalent emission standards.



MODEL	TL943D		TL1055D		TL1055D	
Maximum Lift Height	13.1 m	<b>43'1"</b>	16.7 m	<b>54'9"</b>	16.7 m	<b>54'9"</b>
Maximum Lift Capacity	4081 kg	<b>9000 lb</b>	4536 kg	<b>10,000 lb</b>	4536 kg	<b>10,000 lb</b>
Operating Weight	11 530 kg	<b>25,419 lb</b>	14 460 kg	<b>31,879 lb</b>	14 340 kg	<b>31,614 lb</b>
Flywheel Power (Gross)						
Standard	82 kW	<b>110 hp</b>	106 kW	<b>142 hp</b>	106 kW	<b>142 hp</b>
Engine Model						
Standard	<b>C4.4 Tier 3 equivalent<sup>2</sup></b>		<b>C4.4 ACERT Tier 4 Final<sup>1</sup></b>		<b>C4.4 ACERT Tier 3 equivalent<sup>2</sup></b>	
Rated Engine RPM	<b>2200</b>		<b>2200</b>		<b>2400</b>	
No. of Cylinders	<b>4</b>		<b>4</b>		<b>4</b>	
Standard Engine						
Bore	—		105 mm	<b>4.13"</b>	105 mm	<b>4.13"</b>
Stroke	—		127 mm	<b>4.99"</b>	127 mm	<b>4.99"</b>
Displacement	4.4 L	<b>269 in<sup>3</sup></b>	4.4 L	<b>269 in<sup>3</sup></b>	4.4 L	<b>269 in<sup>3</sup></b>
Speeds Forward:	29.9 km/h	<b>19 mph</b>	<b>km/h</b>	<b>mph</b>	<b>km/h</b>	<b>mph</b>
1st	—		5.1	<b>3.2</b>	5.1	<b>3.2</b>
2nd	—		10.0	<b>6.2</b>	10.0	<b>6.2</b>
3rd	—		22.9	<b>14.2</b>	22.9	<b>14.2</b>
4th	—		33.0	<b>20.5</b>	33.0	<b>20.5</b>
Speeds Reverse:	29.9 km/h	<b>19 mph</b>	<b>km/h</b>	<b>mph</b>	<b>km/h</b>	<b>mph</b>
1st	—		5.1	<b>3.2</b>	5.1	<b>3.2</b>
2nd	—		10.0	<b>6.2</b>	10.0	<b>6.2</b>
3rd	—		22.9	<b>14.2</b>	22.9	<b>14.2</b>
Turning Circle Radius:						
Over Tires	3660 mm	<b>12.0'</b>	4291 mm	<b>14.0'</b>	4291 mm	<b>14.0'</b>
Over Forks	—		5735 mm	<b>18.0'</b>	5735 mm	<b>18.0'</b>
Standard Tires	<b>370/75-28 Air Duraforce</b>		<b>400/75-28 Air Duraforce</b>		<b>400/75-28 Air Duraforce</b>	
Service Refill Capacity:						
Fuel Tank @ 90% Fill	145 L	<b>38.3 U.S. gal</b>	145 L	<b>38.3 U.S. gal</b>	145 L	<b>38.3 U.S. gal</b>
Hydraulic System	177 L	<b>47 U.S. gal</b>	184 L	<b>48.6 U.S. gal</b>	184 L	<b>48.6 U.S. gal</b>

<sup>1</sup> Meets Tier 4 Final/Stage IV/Japan 2014 (Tier 4 Final) emission standards.

<sup>2</sup> Meets Tier 3/Stage IIIA/Japan 2006 (Tier 3) equivalent emission standards.

<b>MODEL</b>	<b>TL1255D</b>		<b>TL1255D</b>	
Maximum Lift Height	16.6 m	<b>54'5"</b>	16.6 m	<b>54'5"</b>
Maximum Lift Capacity	5443 kg	<b>12,000 lb</b>	5443 kg	<b>12,000 lb</b>
Operating Weight	15 586 kg	<b>34,361 lb</b>	15 466 kg	<b>34,097 lb</b>
Flywheel Power (Gross)				
Standard	106 kW	<b>142 hp</b>	106 kW	<b>142 hp</b>
Engine Model				
Standard	<b>C4.4 ACERT Tier 4 Final<sup>1</sup></b>		<b>C4.4 ACERT Tier 3 equivalent<sup>2</sup></b>	
Rated Engine RPM	<b>2200</b>		<b>2400</b>	
No. of Cylinders	<b>4</b>		<b>4</b>	
Standard Engine				
Bore	105 mm	<b>4.13"</b>	105 mm	<b>4.13"</b>
Stroke	127 mm	<b>4.99"</b>	127 mm	<b>4.99"</b>
Displacement	4.4 L	<b>269 in<sup>3</sup></b>	4.4 L	<b>269 in<sup>3</sup></b>
Speeds Forward:	<b>km/h</b>	<b>mph</b>	<b>km/h</b>	<b>mph</b>
1st	5.1	<b>3.2</b>	5.1	<b>3.2</b>
2nd	10.0	<b>6.2</b>	10.0	<b>6.2</b>
3rd	22.9	<b>14.2</b>	22.9	<b>14.2</b>
4th	33.0	<b>20.5</b>	33.0	<b>20.5</b>
Speeds Reverse:	<b>km/h</b>	<b>mph</b>	<b>km/h</b>	<b>mph</b>
1st	5.1	<b>3.2</b>	5.1	<b>3.2</b>
2nd	10.0	<b>6.2</b>	10.0	<b>6.2</b>
3rd	22.9	<b>14.2</b>	22.9	<b>14.2</b>
Turning Circle Radius:				
Over Tires	4291 mm	<b>14.0'</b>	4291 mm	<b>14.0'</b>
Over Forks	5735 mm	<b>18.0'</b>	5735 mm	<b>18.0'</b>
Standard Tires	<b>400/75-28 Air Duraforce</b>		<b>400/75-28 Air Duraforce</b>	
Service Refill Capacity:				
Fuel Tank @ 90% Fill	145 L	<b>38.3 U.S. gal</b>	145 L	<b>38.3 U.S. gal</b>
Hydraulic System	189 L	<b>49.9 U.S. gal</b>	189 L	<b>49.9 U.S. gal</b>

<sup>1</sup> Meets Tier 4 Final/Stage IV/Japan 2014 (Tier 4 Final) emission standards.

<sup>2</sup> Meets Tier 3/Stage IIIA/Japan 2006 (Tier 3) equivalent emission standards.

**TH255C**  
**ROW Version**

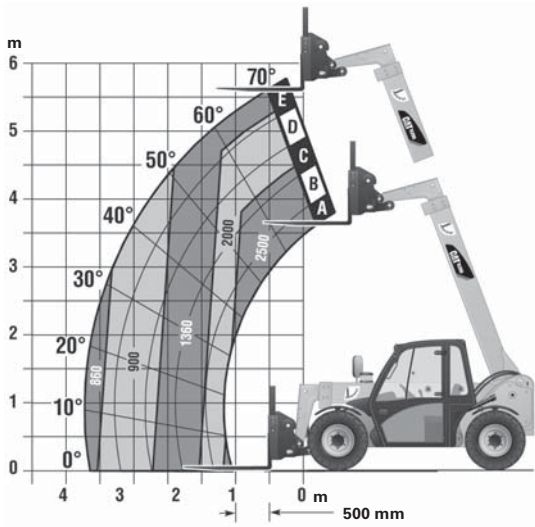

**TH255C**  
**North American Version**

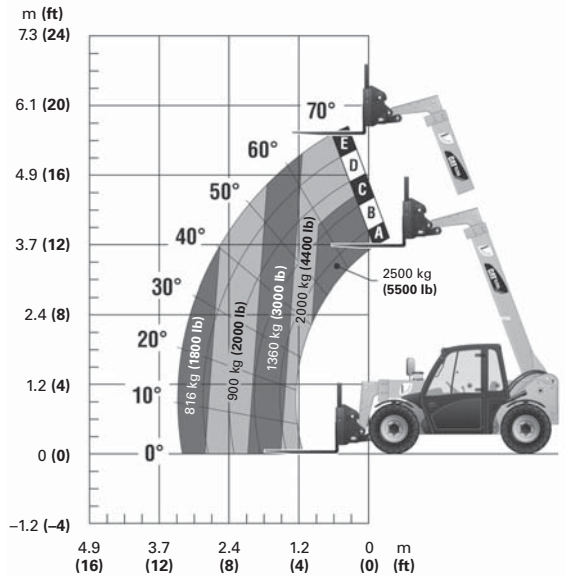

Numbers in chart measured in kilograms.

Maximum lift capacity	2500 kg	<b>5500 lb</b>
Maximum lift height	5.6 m	<b>18'4"</b>
Load at maximum height	1360 kg	<b>2998 lb</b>
Maximum forward reach	3.25 m	<b>10'10"</b>
Load at maximum reach	860 kg	<b>1896 lb</b>

Maximum lift capacity	2500 kg	<b>5500 lb</b>
Maximum lift height	5.6 m	<b>18'4"</b>
Load at maximum height	2000 kg	<b>4400 lb</b>
Maximum forward reach	3.25 m	<b>10'10"</b>
Load at maximum reach	816 kg	<b>1800 lb</b>

TH306D

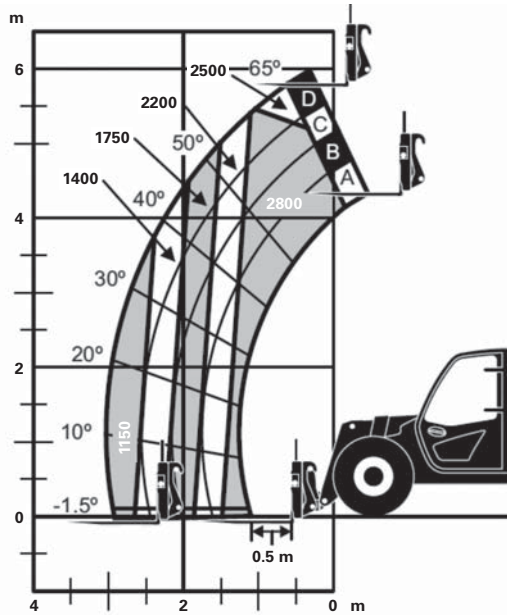

Numbers in chart measured in kilograms.

Maximum lift capacity	2800 kg	<b>6172 lb</b>
Maximum lift height	5.8 m	<b>19'0"</b>
Load at maximum height	2500 kg	<b>5511 lb</b>
Maximum forward reach	3100 mm	<b>10.1 ft</b>
Load at maximum reach	1150 kg	<b>2535 lb</b>

TH336C

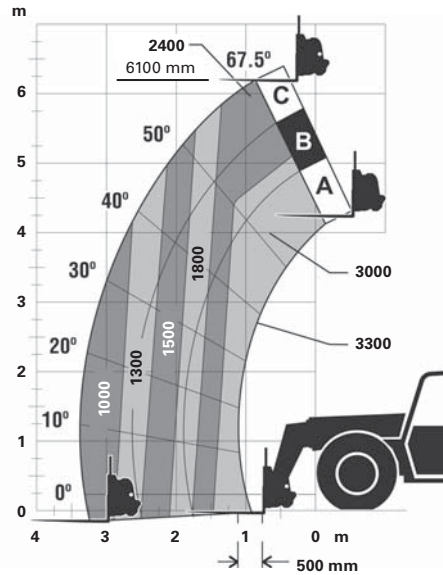

Numbers in chart measured in kilograms.

Maximum lift capacity	3300 kg	<b>7275 lb</b>
Maximum lift height	6.1 m	<b>20'0"</b>
Load at maximum height	2400 kg	<b>5291 lb</b>
Maximum forward reach	3.11 m	<b>10'2"</b>
Load at maximum reach	1000 kg	<b>2204 lb</b>

**TH337C**

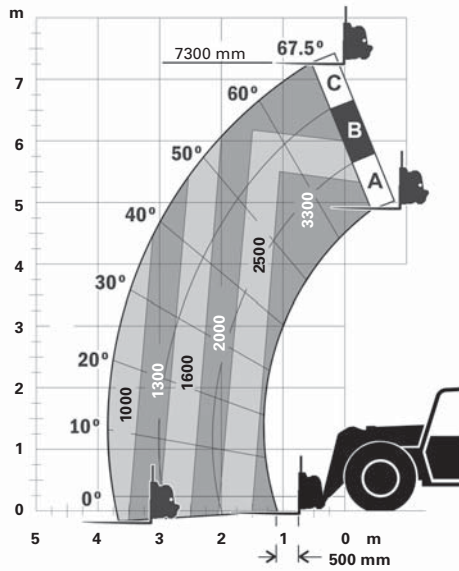

**TH406C**

**North American Version**

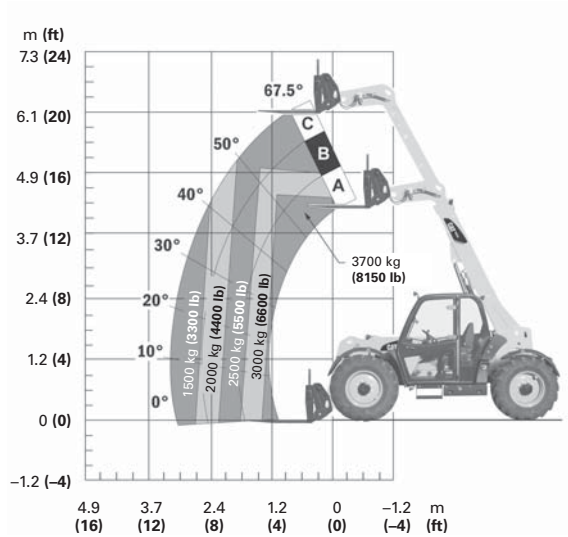

Numbers in chart measured in kilograms.

Maximum lift capacity	3300 kg	<b>7275 lb</b>
Maximum lift height	7.3 m	<b>24'0"</b>
Load at maximum height	2000 kg	<b>4409 lb</b>
Maximum forward reach	3.76 m	<b>12'4"</b>
Load at maximum reach	1000 kg	<b>2204 lb</b>

Maximum lift capacity	3700 kg	<b>8150 lb</b>
Maximum lift height	6.1 m	<b>20'0"</b>
Load at maximum height	2500 kg	<b>5511 lb</b>
Maximum forward reach	3.11 m	<b>10'2"</b>
Load at maximum reach	1500 kg	<b>3300 lb</b>

**TH406C**  
**ROW Version**

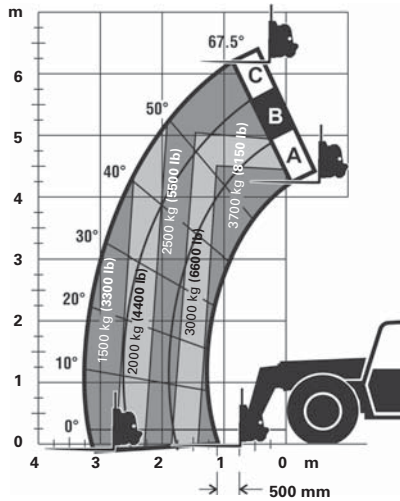

**TH407C**  
**ROW Version**

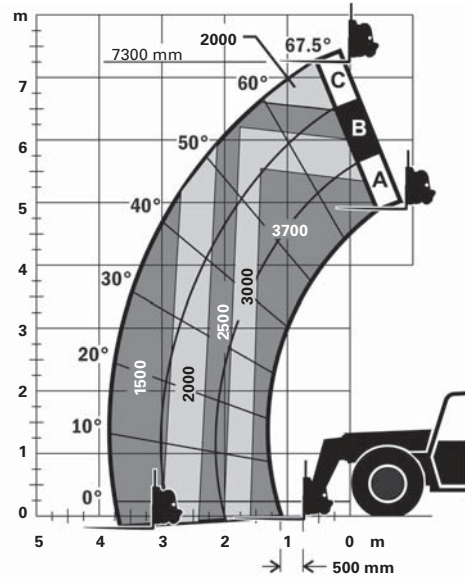

Numbers in chart measured in kilograms.

Maximum lift capacity	3700 kg	<b>8150 lb</b>
Maximum lift height	6.1 m	<b>20'0"</b>
Load at maximum height	2500 kg	<b>5511 lb</b>
Maximum forward reach	3.11 m	<b>10'2"</b>
Load at maximum reach	1500 kg	<b>3300 lb</b>

Maximum lift capacity	3700 kg	<b>8150 lb</b>
Maximum lift height	7.3 m	<b>24'0"</b>
Load at maximum height	2000 kg	<b>4410 lb</b>
Maximum forward reach	3.76 m	<b>12'4"</b>
Load at maximum reach	1500 kg	<b>3300 lb</b>

**TH407C**

**North American Version**

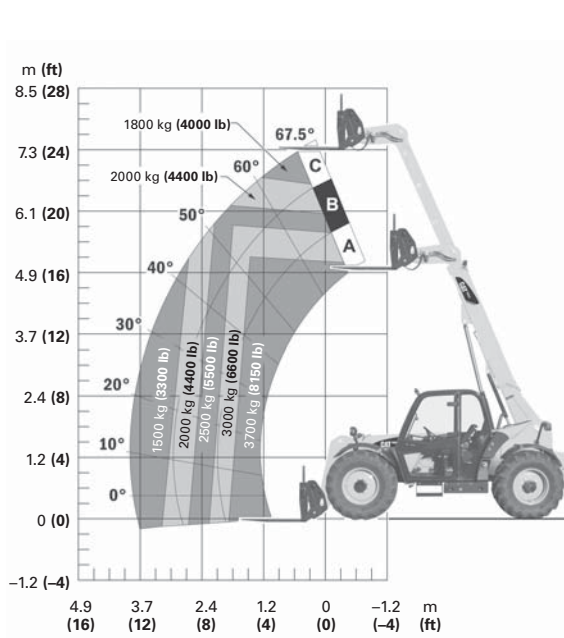

**TH3510D**

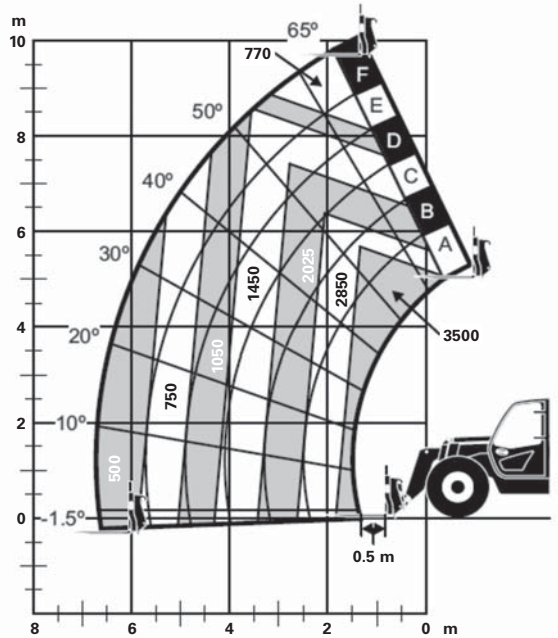

Numbers in chart measured in kilograms.

Maximum lift capacity	3700 kg	<b>8150 lb</b>
Maximum lift height	7.3 m	<b>24'0"</b>
Load at maximum height	1800 kg	<b>4000 lb</b>
Maximum forward reach	3.76 m	<b>12'4"</b>
Load at maximum reach	1500 kg	<b>3300 lb</b>

Maximum lift capacity	3500 kg	<b>7716 lb</b>
Maximum lift height	9.8 m	<b>32.1'</b>
Load at maximum height	770 kg	<b>1698 lb</b>
Maximum forward reach	6600 mm	<b>21.8 ft</b>
Load at maximum reach	500 kg	<b>1102 lb</b>

**TH414C**  
**Stabilizers Up**

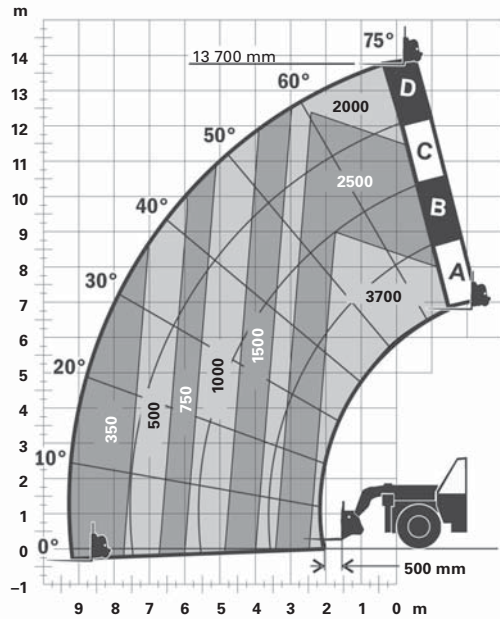

Numbers in chart measured in kilograms.

Maximum lift capacity	3700 kg	<b>8150 lb</b>
Maximum lift height	13.7 m	<b>44'11"</b>
Load at maximum height	2000 kg	<b>4410 lb</b>
Maximum forward reach	9.23 m	<b>30'3"</b>
Load at maximum reach	350 kg	<b>771 lb</b>

**TH414C**  
**Stabilizers Down**

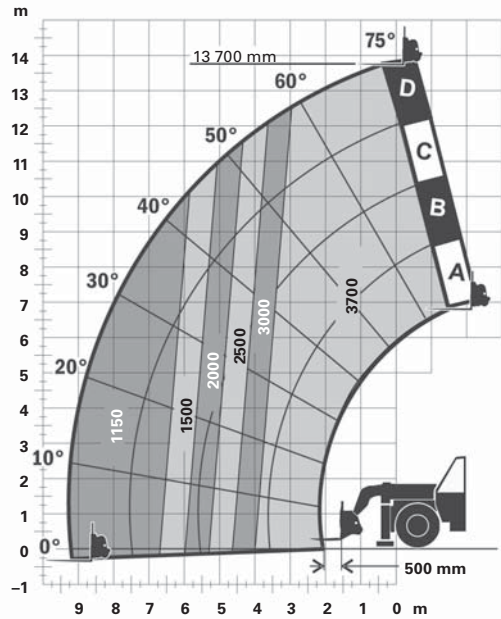

Numbers in chart measured in kilograms.

Maximum lift capacity	3700 kg	<b>8150 lb</b>
Maximum lift height	13.7 m	<b>44'11"</b>
Load at maximum height	3700 kg	<b>8150 lb</b>
Maximum forward reach	9.23 m	<b>30'3"</b>
Load at maximum reach	1150 kg	<b>2535 lb</b>



**TH417C**  
**Stabilizers Up**

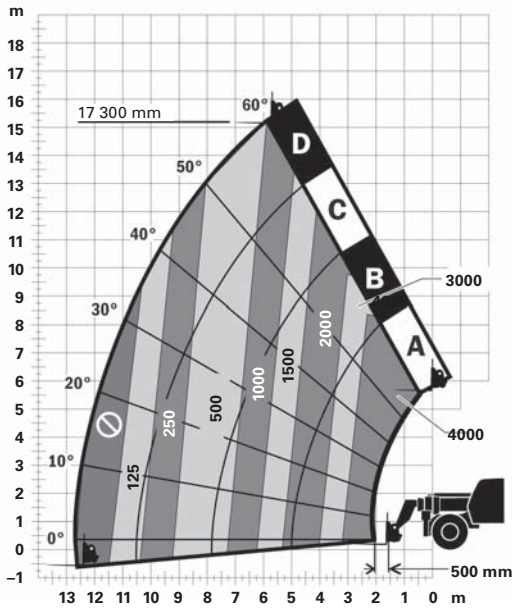

Numbers in chart measured in kilograms.

Maximum lift capacity	4000 kg	<b>8820 lb</b>
Maximum lift height	15.3 m	<b>50'2"</b>
Load at maximum height	1000 kg	<b>2200 lb</b>
Maximum forward reach	12.7 m	<b>41'8"</b>
Load at maximum reach	0 kg	<b>0 lb</b>

**TH417C**  
**Stabilizers Down**

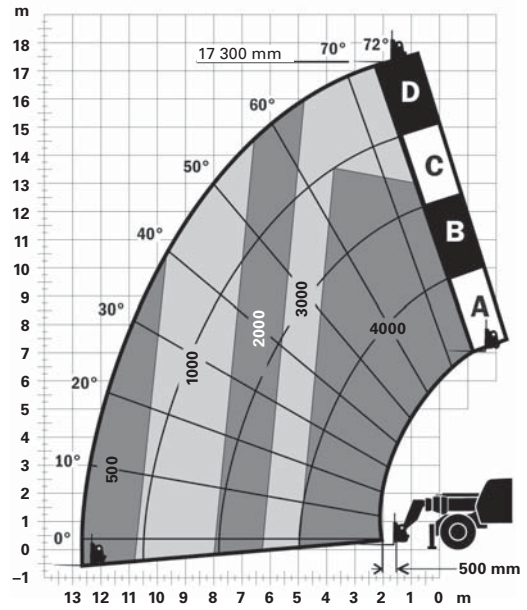

Numbers in chart measured in kilograms.

Maximum lift capacity	4000 kg	<b>8820 lb</b>
Maximum lift height	17.3 m	<b>56'10"</b>
Load at maximum height	3000 kg	<b>6610 lb</b>
Maximum forward reach	12.7 m	<b>41'8"</b>
Load at maximum reach	500 kg	<b>1100 lb</b>

**TH514C**  
**Stabilizers Up**

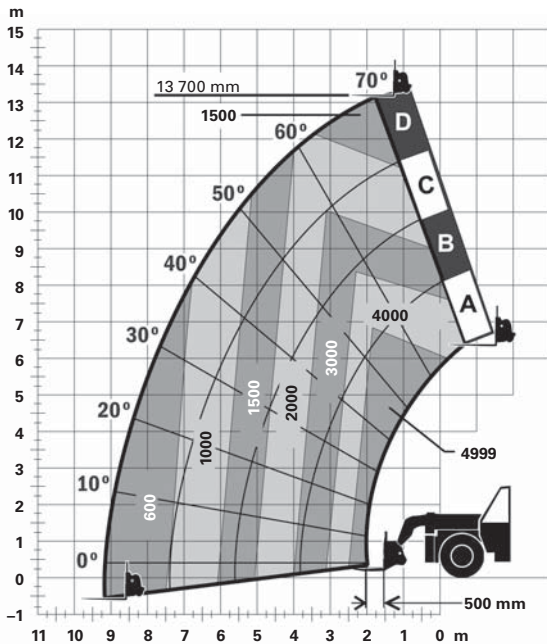

Numbers in chart measured in kilograms.

Maximum lift capacity	4999 kg	<b>11,020 lb</b>
Maximum lift height	13.4 m	<b>44'0"</b>
Load at maximum height	1500 kg	<b>3306 lb</b>
Maximum forward reach	9.22 m	<b>30'3"</b>
Load at maximum reach	600 kg	<b>1322 lb</b>

**TH514C**  
**Stabilizers Down**

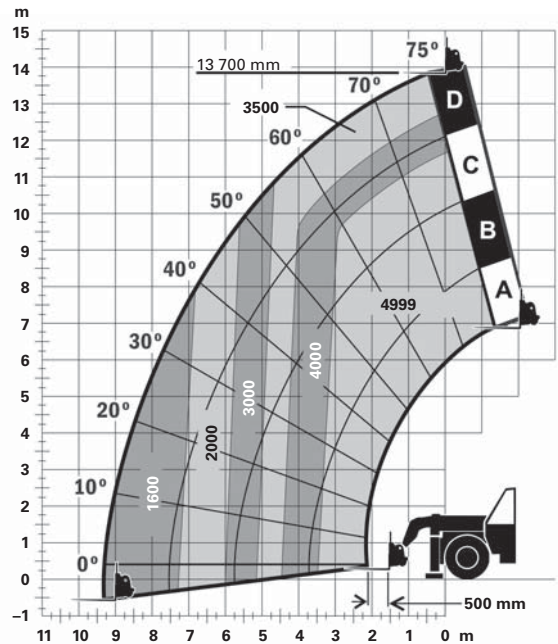

Numbers in chart measured in kilograms.

Maximum lift capacity	4999 kg	<b>11,020 lb</b>
Maximum lift height	13.7 m	<b>44'11"</b>
Load at maximum height	3500 kg	<b>7716 lb</b>
Maximum forward reach	9.22 m	<b>30'3"</b>
Load at maximum reach	1600 kg	<b>3527 lb</b>

**TL642C**  
**No Stabilizers**

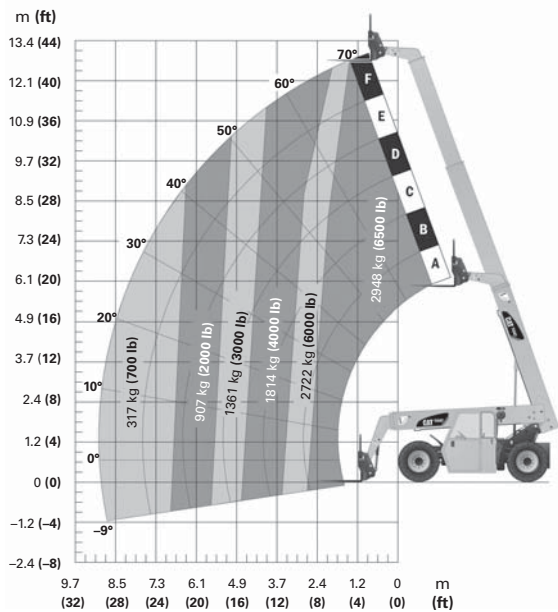

Maximum lift capacity	2948 kg	<b>6500 lb</b>
Maximum lift height	12.8 m	<b>42'0"</b>
Load at maximum height	2948 kg	<b>6500 lb</b>
Maximum forward reach	9.1 m	<b>30'0"</b>
Load at maximum reach	317 kg	<b>700 lb</b>

**TL642C**  
**Stabilizers Up**

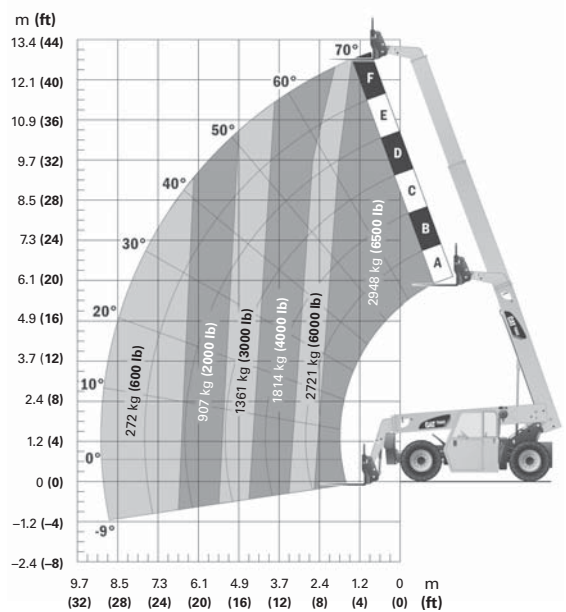

Maximum lift capacity	2948 kg	<b>6500 lb</b>
Maximum lift height	12.8 m	<b>42'0"</b>
Load at maximum height	2948 kg	<b>6500 lb</b>
Maximum forward reach	9.1 m	<b>30'0"</b>
Load at maximum reach	272 kg	<b>600 lb</b>

**TL642C**

**Stabilizers Down**

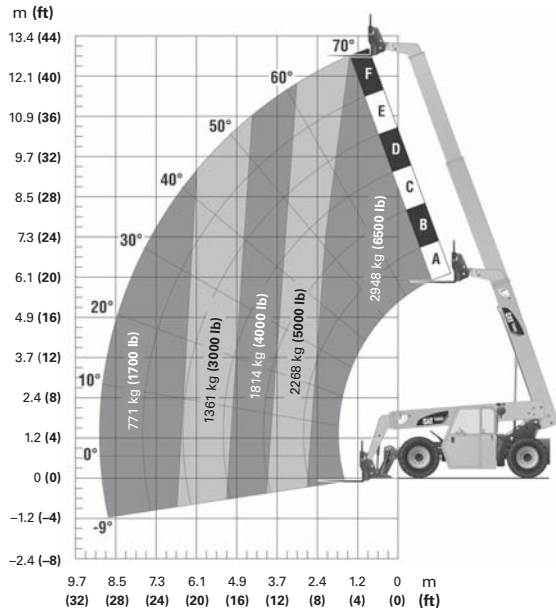

**TL943C**

**No Stabilizers**

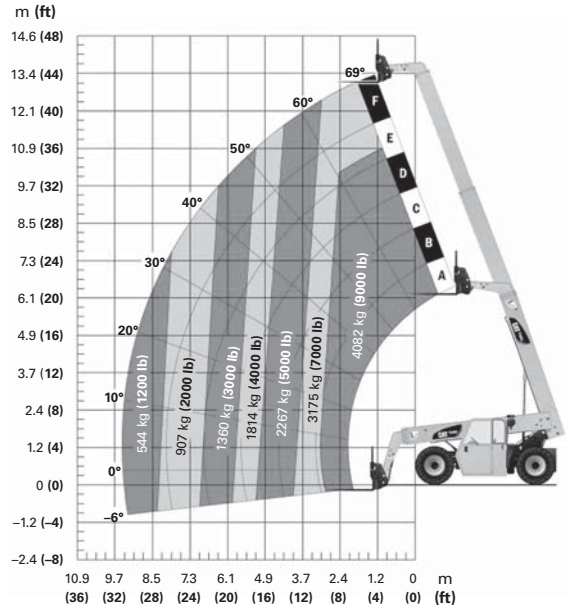

Maximum lift capacity	2948 kg	<b>6500 lb</b>
Maximum lift height	12.8 m	<b>42'0"</b>
Load at maximum height	2948 kg	<b>6500 lb</b>
Maximum forward reach	9.1 m	<b>30'0"</b>
Load at maximum reach	771 kg	<b>1700 lb</b>

Maximum lift capacity	4082 kg	<b>9000 lb</b>
Maximum lift height	13.1 m	<b>43'0"</b>
Load at maximum height	3175 kg	<b>7000 lb</b>
Maximum forward reach	9.6 m	<b>31'5"</b>
Load at maximum reach	544 kg	<b>1200 lb</b>

**TL943C**

**Stabilizers Up**

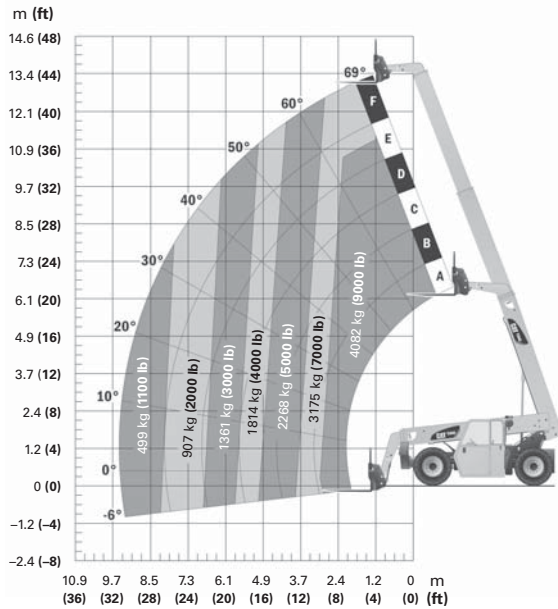

**TL943C**

**Stabilizers Down**

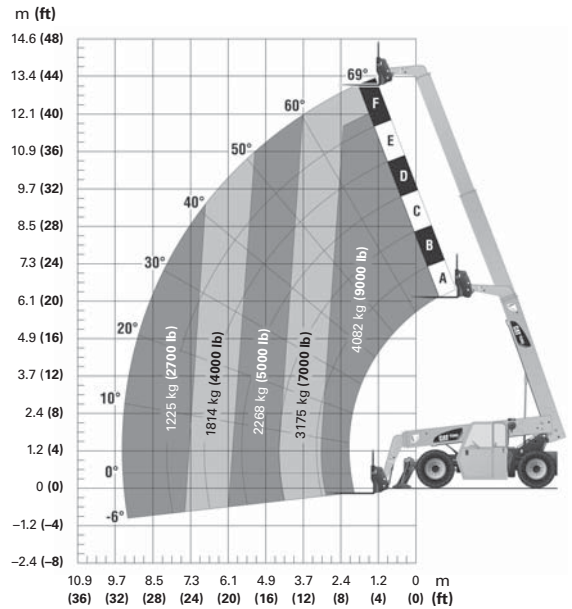

Maximum lift capacity	4082 kg	<b>9000 lb</b>
Maximum lift height	13.1 m	<b>43'0"</b>
Load at maximum height	3175 kg	<b>7000 lb</b>
Maximum forward reach	9.6 m	<b>31'5"</b>
Load at maximum reach	499 kg	<b>1100 lb</b>

Maximum lift capacity	4082 kg	<b>9000 lb</b>
Maximum lift height	13.1 m	<b>43'0"</b>
Load at maximum height	3175 kg	<b>7000 lb</b>
Maximum forward reach	9.6 m	<b>31'5"</b>
Load at maximum reach	1225 kg	<b>2700 lb</b>

**TL1055C**  
**Stabilizers Up**

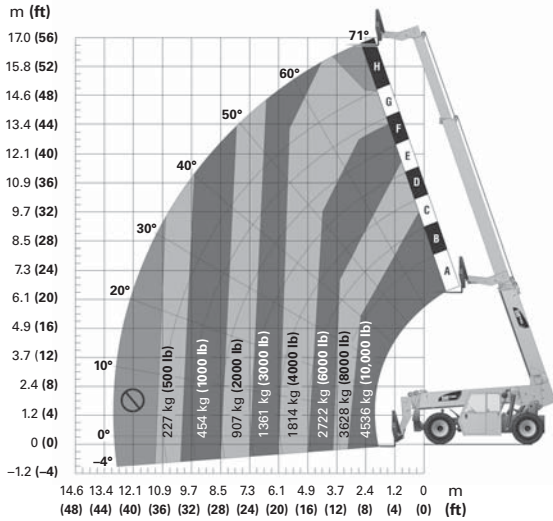

**TL1055C**  
**Stabilizers Down**

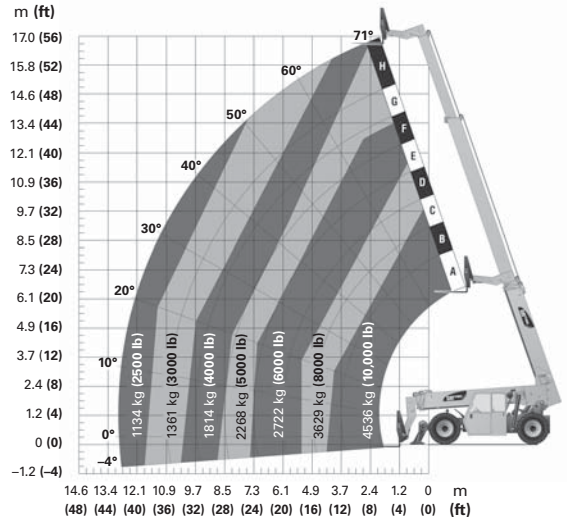

Maximum lift capacity	4536 kg	<b>10,000 lb</b>
Maximum lift height	16.8 m	<b>55'0"</b>
Load at maximum height	0 kg	<b>0 lb</b>
Maximum forward reach	13.0 m	<b>42'6"</b>
Load at maximum reach	0 kg	<b>0 lb</b>

Maximum lift capacity	4536 kg	<b>10,000 lb</b>
Maximum lift height	16.8 m	<b>55'1"</b>
Load at maximum height	2268 kg	<b>5000 lb</b>
Maximum forward reach	13.0 m	<b>42'6"</b>
Load at maximum reach	1134 kg	<b>2500 lb</b>

**TL1255C**  
**Stabilizers Up**

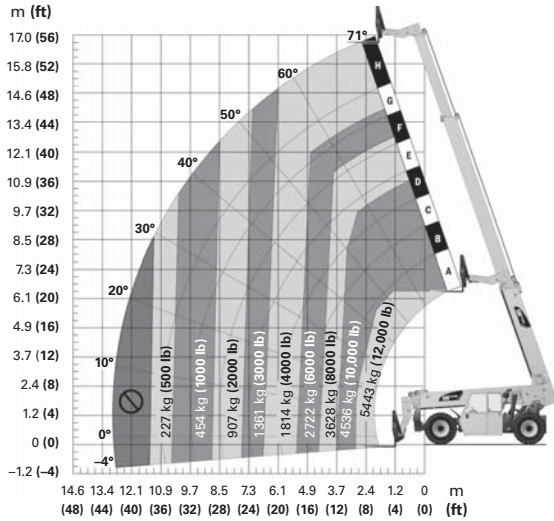

**TL1255C**  
**Stabilizers Down**

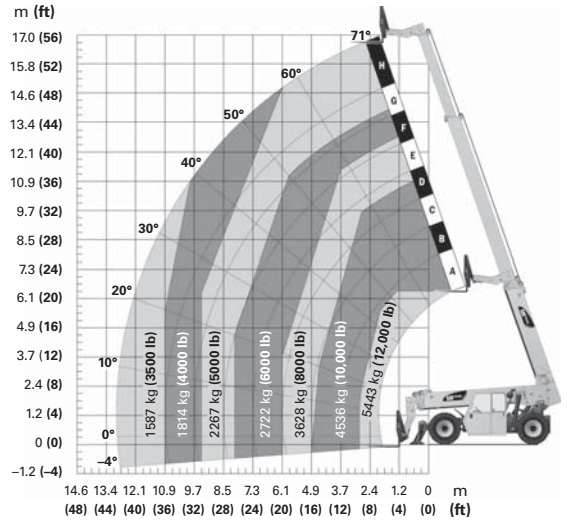

Maximum lift capacity	5443 kg	<b>12,000 lb</b>
Maximum lift height	16.6 m	<b>54'5"</b>
Load at maximum height	1814 kg	<b>4000 lb</b>
Maximum forward reach	13.0 m	<b>42'6"</b>
Load at maximum reach	0 kg	<b>0 lb</b>

Maximum lift capacity	5443 kg	<b>12,000 lb</b>
Maximum lift height	16.6 m	<b>54'5"</b>
Load at maximum height	2267 kg	<b>5000 lb</b>
Maximum forward reach	13.0 m	<b>42'6"</b>
Load at maximum reach	1588 kg	<b>3500 lb</b>

**TL642D**  
**Stabilizers Up**

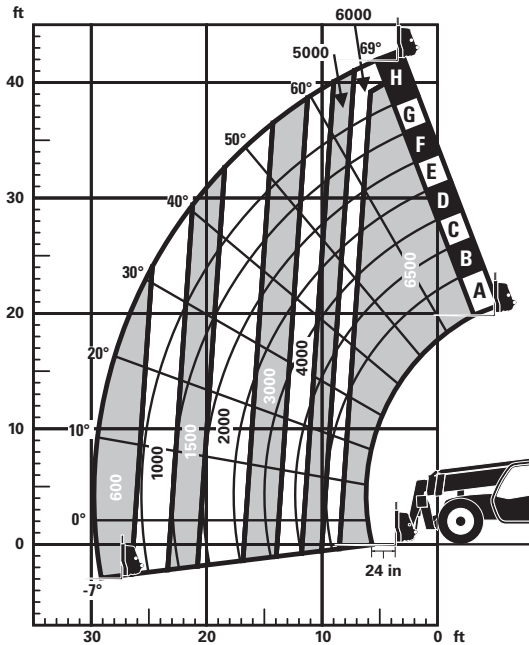

Numbers in chart measured in pounds.

Maximum lift capacity	2948 kg	<b>6500 lb</b>
Maximum lift height	12.8 m	<b>41'11"</b>
Load at maximum height	2948 kg	<b>6000 lb</b>
Maximum forward reach	9051 mm	<b>29.7 ft</b>
Load at maximum reach	272 kg	<b>600 lb</b>

**TL642D**  
**Stabilizers Down**

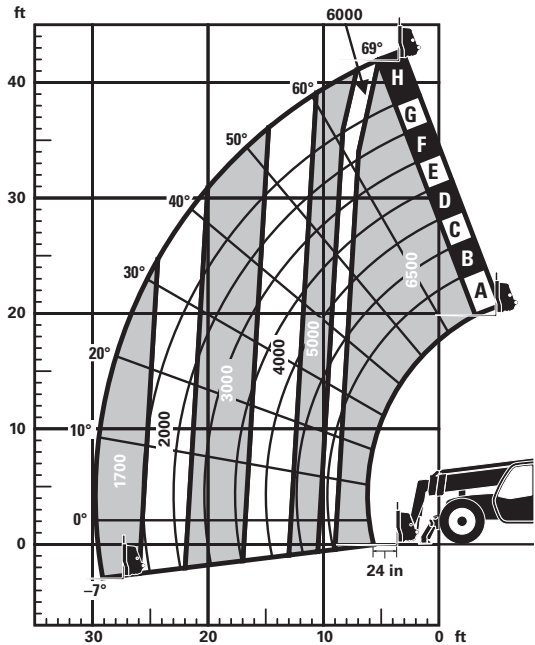

Numbers in chart measured in pounds.

Maximum lift capacity	2948 kg	<b>6500 lb</b>
Maximum lift height	12.8 m	<b>41'11"</b>
Load at maximum height	2993 kg	<b>6000 lb</b>
Maximum forward reach	9051 mm	<b>29.7 ft</b>
Load at maximum reach	771 kg	<b>1700 lb</b>



**TL943D**  
**Stabilizers Up**

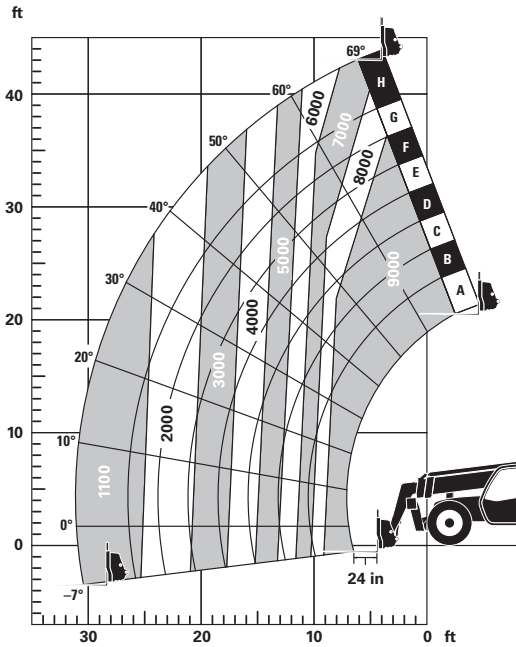

Numbers in chart measured in pounds.

Maximum lift capacity	4082 kg	<b>9000 lb</b>
Maximum lift height	13.1 m	<b>43'1"</b>
Load at maximum height	3175 kg	<b>7000 lb</b>
Maximum forward reach	9467 mm	<b>31 ft</b>
Load at maximum reach	499 kg	<b>1100 lb</b>

**TL943D**  
**Stabilizers Down**

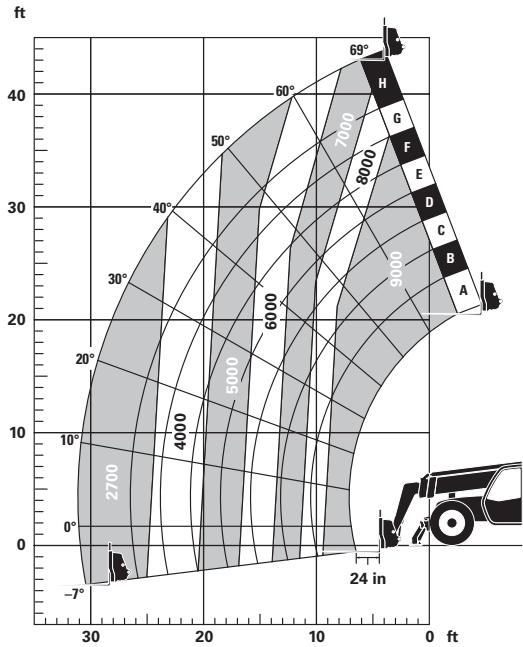

Numbers in chart measured in pounds.

Maximum lift capacity	4082 kg	<b>9000 lb</b>
Maximum lift height	13.1 m	<b>43'1"</b>
Load at maximum height	3175 kg	<b>7000 lb</b>
Maximum forward reach	9467 mm	<b>31 ft</b>
Load at maximum reach	1225 kg	<b>2700 lb</b>

**TL1055D**  
**Stabilizers Up**

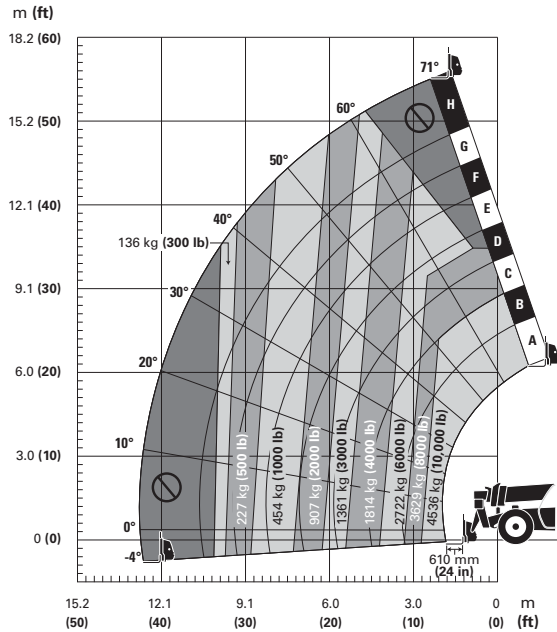

**TL1055D**  
**Stabilizers Down**

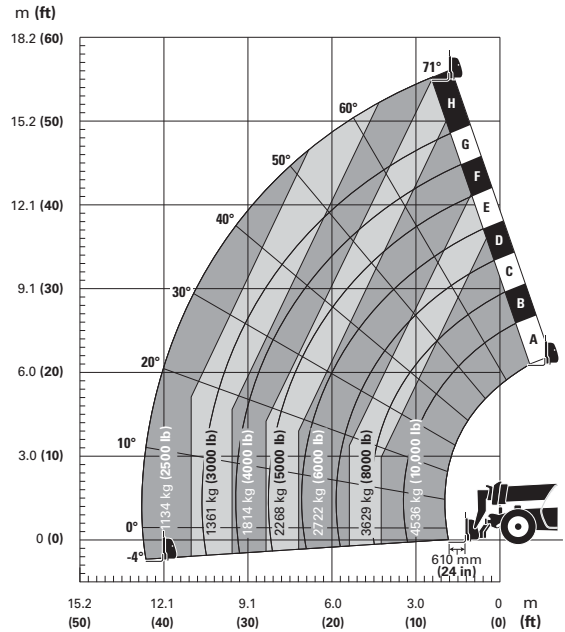

Maximum lift capacity	4536 kg	<b>10,000 lb</b>
Maximum lift height	16.8 m	<b>55'0"</b>
Load at maximum height	0 kg	<b>0 lb</b>
Maximum forward reach	13.0 m	<b>42'6"</b>
Load at maximum reach	0 kg	<b>0 lb</b>

Maximum lift capacity	4536 kg	<b>10,000 lb</b>
Maximum lift height	16.8 m	<b>55'1"</b>
Load at maximum height	2268 kg	<b>5000 lb</b>
Maximum forward reach	13.0 m	<b>42'6"</b>
Load at maximum reach	1134 kg	<b>2500 lb</b>

TL1255D

Stabilizers Up

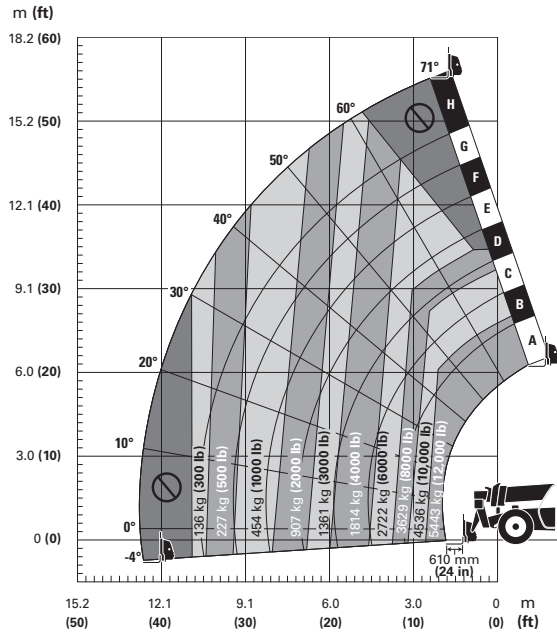

TL1255D

Stabilizers Down

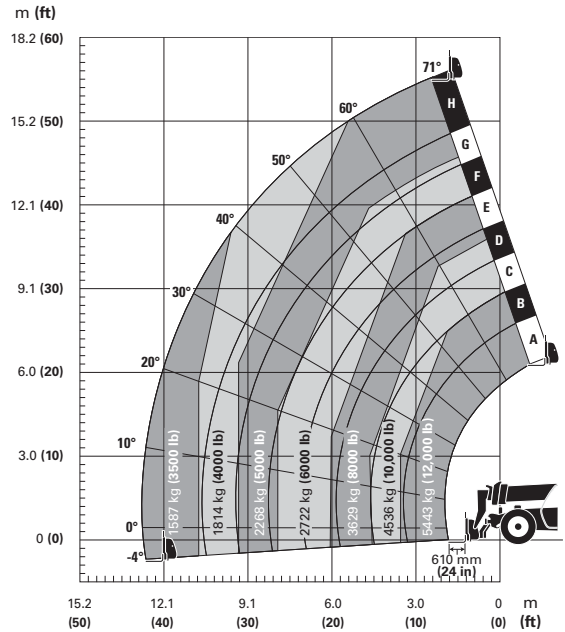

Maximum lift capacity	5443 kg	12,000 lb
Maximum lift height	16.6 m	54'5"
Load at maximum height	1814 kg	4000 lb
Maximum forward reach	13.0 m	42'6"
Load at maximum reach	0 kg	0 lb

Maximum lift capacity	5443 kg	12,000 lb
Maximum lift height	16.6 m	54'5"
Load at maximum height	2268 kg	5000 lb
Maximum forward reach	13.0 m	42'6"
Load at maximum reach	1588 kg	3500 lb

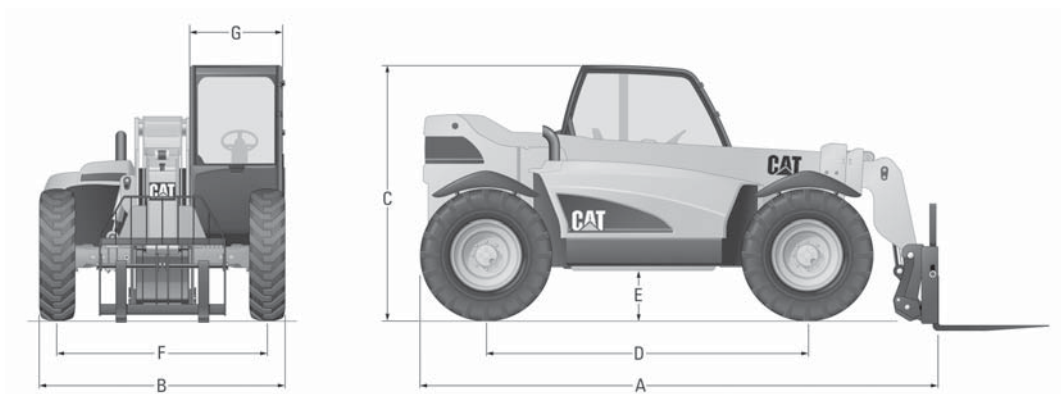
**Dimensions (approx.)**

Model	TH255C		TH306D		TH336C		TH337C	
	mm	ft	mm	ft	mm	ft	mm	ft
A) Length to fork face	3800	12'5"	4400	14.4'	4850	15'11"	5128	16'9"
B) Width	1800	5'10"	2100	6.8'	2382	7'10"	2382	7'10"
C) Height	1900	6'2"	2250	7.3'	2419	7.9'	2489	8.1'
D) Wheel base	2300	7'6"	2770	9.1'	2975	9'9"	3075	10'1"
E) Ground clearance	270	10"	390	1.2'	409	1'4"	430	1'5"
F) Wheel track	—		—		1988	6'6"	1988	6'6"
G) Cab width (inside)								
Standard	864	2'10"	—		880	2'11"	880	2'11"
Agriculture	N/A		—		920	3'0"	920	3'0"

Model	TH406C		TH407C		TH3510D		TH414C	
	mm	ft	mm	ft	mm	ft	mm	ft
A) Length to fork face	4850	15'11"	5347	17'6"	5272	17.2'	6575	21'4"
B) Width	2382	7'10"	2382	7'10"	2382	7.8'	2430	7'11"
C) Height	2419	7.9'	2489	8.1'	2475	8.1'	2588	8'6"
D) Wheel base	2975	9'9"	3075	10'1"	3165	10.4'	3200	10'6"
E) Ground clearance	409	1'4"	430	1'5"	429	1.4'	407	1'4"
F) Wheel track	1988	6'6"	1988	6'6"	—		2036	6'8"
G) Cab width (inside)								
Standard	880	2'11"	880	2'11"	—		880	2'11"
Agriculture	920	3'0"	920	3'0"	—		N/A	

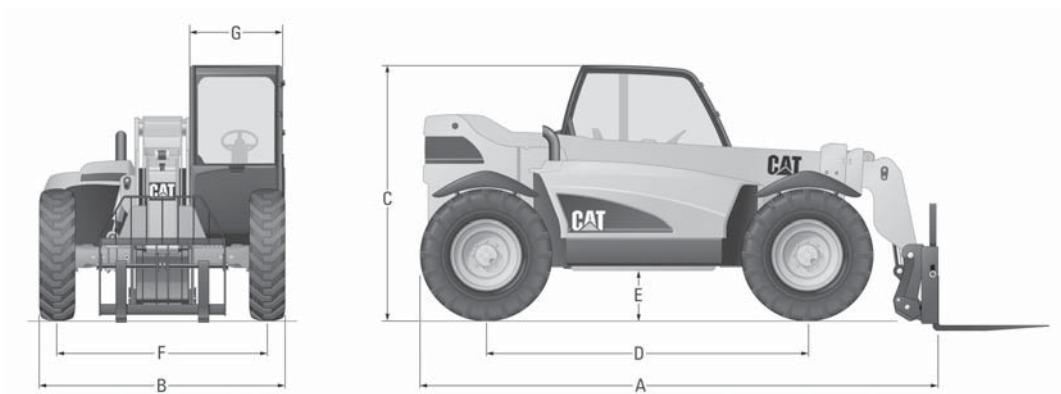

**Dimensions (approx.)**

Model	TH417C		TH514C		TL642C		TL943C	
	mm	ft	mm	ft	mm	ft	mm	ft
A) Length to fork face	6782	22'3"	6617	21'8"	5629	18'5"	6248	20'5"
B) Width	2440	8'0"	2440	8'0"	2426	8'0"	2426	8'0"
C) Height	2805	9'2"	2610	8'7"	2388	7'8"	2426	8'0"
D) Wheel base	3200	10'6"	3200	10'6"	3251	10'7"	3353	11'0"
E) Ground clearance	386	1'3"	430	1'5"	417	1'4"	483	1'7"
F) Wheel track	2078	6'10"	2078	6'10"	2108	6'9"	2108	6'9"
G) Cab width (inside)	880	2'11"	880	2'11"	940	3'1"	940	3'1"

Model	TL1055C		TL1255C		TL642D		TL943D	
	mm	ft	mm	ft	mm	ft	mm	ft
A) Length to fork face	6325	20'8"	6325	20'8"	5980	19'7"	5980	19'7"
B) Width	2565	8'4"	2565	8'4"	2470	8'1"	2470	8'1"
C) Height	2565	8'4"	2565	8'4"	2430	8'0"	2430	8'0"
D) Wheel base	3658	12'0"	3658	12'0"	3430	11'3"	3430	11'3"
E) Ground clearance	457	1'6"	483	1'7"	432	1'5"	432	1'5"
F) Wheel track	2159	7'1"	2159	7'1"	—	—	—	—
G) Cab width (inside)	940	3'1"	940	3'1"	—	—	—	—

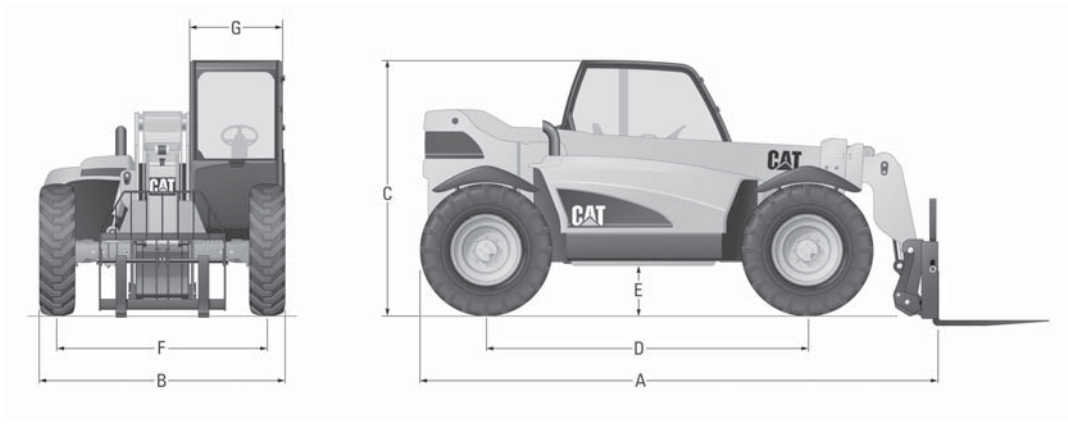
**Dimensions (approx.)**

Model	TL1055D		TL1255D	
	mm	ft	mm	ft
A) Length to fork face	6372	20'9"	6372	20'9"
B) Width	2559	8'4"	2559	8'4"
C) Height	2540	8'3"	2540	8'3"
D) Wheel base	3493	11'5"	3493	11'5"
E) Ground clearance	457	1'5"	457	1'5"
F) Wheel track	2140	7'0"	2140	7'0"
G) Cab width (inside)	900	3'0"	900	3'0"

All carriages are bar type with load backrest to support bulky loads.  
Widespread carriages provide added stability for lifting larger loads.  
Standard and widespread carriages are also available in rotating mode.

Carriage Type

Model	Standard		Standard — Framers		Rotate		Rotate — Framers		Side Shift	
<b>TH255</b>										
Weight w/1220 mm (48") forks	261 kg	<b>575 lb</b>	367 kg	<b>810 lb</b>	—	—	—	—	—	—
Width	1219 mm	<b>4'0"</b>	1219 mm	<b>4'0"</b>	1219 mm	<b>4'0"</b>	—	—	—	—
Height	1118 mm	<b>3'7"</b>	1118 mm	<b>3'7"</b>	1168 mm	<b>3'10"</b>	—	—	—	—
Max. fork spread	1067 mm	<b>3'5"</b>	1092 mm	<b>3'6"</b>	1067 mm	<b>3'5"</b>	—	—	—	—
Floating fork movement	76 mm	<b>3"</b>	76 mm	<b>3"</b>	76 mm	<b>3"</b>	—	—	—	—
<b>TH336 through TH417</b>										
Weight w/1220 mm (48") forks	272 kg	<b>600 lb</b>	336 kg	<b>740 kg</b>	408 kg	<b>900 lb</b>	492 kg	<b>1084 lb</b>	422 kg	<b>930 lb</b>
Width	1224 mm	<b>4'0"</b>	1880 mm	<b>6'2"</b>	1224 mm	<b>4'0"</b>	1880 mm	<b>6'2"</b>	1230 mm	<b>4'0"</b>
Height	1039 mm	<b>3'5"</b>	1039 mm	<b>3'5"</b>	1216 mm	<b>4'0"</b>	1216 mm	<b>4'0"</b>	1135 mm	<b>3'8"</b>
Max. fork spread	1200 mm	<b>3'11"</b>	1856 mm	<b>6'1"</b>	1200 mm	<b>3'11"</b>	1856 mm	<b>6'1"</b>	1200 mm	<b>3'11"</b>
Floating fork movement	70 mm	<b>3"</b>	70 mm	<b>3"</b>	70 mm	<b>3"</b>	70 mm	<b>3"</b>	70 mm	<b>3"</b>
Rotation	—	—	—	—	<b>11.5°</b>	<b>11.5°</b>	<b>11.5°</b>	<b>11.5°</b>	—	—
<b>TH514</b>										
Weight w/1220 mm (48") forks	303 kg	<b>600 lb</b>	336 kg	<b>740 lb</b>	408 kg	<b>900 lb</b>	492 kg	<b>1084 lb</b>	422 kg	<b>930 lb</b>
Width	1224 mm	<b>4'0"</b>	1880 mm	<b>6'2"</b>	1224 mm	<b>4'0"</b>	1880 mm	<b>6'2"</b>	1230 mm	<b>4'0"</b>
Height	1039 mm	<b>3'5"</b>	1039 mm	<b>3'5"</b>	1216 mm	<b>4'0"</b>	1216 mm	<b>4'0"</b>	1135 mm	<b>3'8"</b>
Max. fork spread	1200 mm	<b>3'11"</b>	1856 mm	<b>6'1"</b>	1200 mm	<b>3'11"</b>	1856 mm	<b>6'1"</b>	1200 mm	<b>3'11"</b>
Floating fork movement	70 mm	<b>3"</b>	70 mm	<b>3"</b>	70 mm	<b>3"</b>	70 mm	<b>3"</b>	70 mm	<b>3"</b>
Rotation	—	—	—	—	<b>11.5°</b>	<b>11.5°</b>	<b>11.5°</b>	<b>11.5°</b>	—	—

Model	Carriage Type					
	Standard		Standard – Framers		Rotate 1270 mm (50")	
<b>TL642C, TL943C, TL1055C, TL1255C, TL642D, TL943D</b>						
Weight* w/1220 mm (48") forks (51 mm × 51 mm/2" × 2")	295 kg	<b>650 lb</b>	363 kg	<b>800 lb</b>	454 kg	<b>1000 lb</b>
Width**	1422 mm	<b>56"</b>	1981 mm	<b>78"</b>	1422 mm	<b>56"</b>
Height**	1270 mm	<b>50"</b>	1067 mm	<b>42"</b>	1270 mm	<b>50"</b>
Max. fork spread (out to out)	1270 mm	<b>50"</b>	1829 mm	<b>72"</b>	1270 mm	<b>50"</b>
Floating fork movement	98 mm	<b>3.9"</b>	98 mm	<b>3.9"</b>	98 mm	<b>3.9"</b>
Rotation	—		—		<b>±10°</b>	

\*Weights are for information purposes only. Refer to applicable load charts for specific data.

\*\*Dimensions are approximate.

Model	Carriage Type					
	Rotate – Framers 1830 mm (72")		Side Shift ±102 mm (±4")		Swing	
<b>TL642C, TL943C, TL1055C, TL1255C, TL642D, TL943D, TL1055D, TL1255D</b>						
Weight* w/1220 mm (48") forks (51 mm × 51 mm/2" × 2")	522 kg	<b>1150 lb</b>	363 kg	<b>800 lb</b>	975 kg	<b>2150 lb</b>
Width**	1981 mm	<b>78"</b>	1245 mm	<b>49"</b>	1772 mm	<b>69.75"</b>
Height**	1067 mm	<b>42"</b>	1041 mm	<b>41"</b>	1194 mm	<b>47"</b>
Max. fork spread (out to out)	1829 mm	<b>72"</b>	1162 mm	<b>45.75"</b>	1854 mm	<b>73"</b>
Floating fork movement	98 mm	<b>3.9"</b>	51 mm	<b>2"</b>	76 mm	<b>3"</b>
Rotation	<b>±10°</b>		—		<b>100°</b>	

\*Weights are for information purposes only. Refer to applicable load charts for specific data.

\*\*Dimensions are approximate.



All carriages are bar type with load backrest to support bulky loads.  
Widespread carriages provide added stability for lifting larger loads.  
Standard and widespread carriages are also available in rotating mode.

---

**Non-U.S. Models**

---

**Fork Type**

---

**Pallet**

---

Model	Forks/Sets	Size	
TH255C, TH306D, TH336C, TH337C, TH406C, TH407C, TH3510D, TH414C, TH417C	2	45 mm × 100 mm × 1070 mm	1.77" × 4" × 42"
TH255C, TH306D, TH406C, TH407C, TH3510D, TH514C	2	50 mm × 100 mm × 1220 mm	2" × 4" × 48"
TH306D, TH406C, TH407C, TH3510D, TH514C	2	50 mm × 125 mm × 1220 mm	2" × 5" × 48"
TH255C, TH306D, TH336C, TH337C, TH406C, TH407C, TH3510D, TH414C, TH417C	2	50 mm × 100 mm × 1525 mm	2" × 4" × 60"
TH255C, TH306D, TH336C, TH337C, TH406C, TH407C, TH3510D, TH414C, TH417C, TH514C	2	50 mm × 100 mm × 1200 mm	2" × 4" × 47"
TH255C, TH306D, TH336C, TH337C, TH406C, TH407C, TH3510D, TH414C, TH417C, TH514C, TL642C, TL943C, TL1055C, TL1055D	2	60 mm × 100 mm × 1220 mm	2.36" × 4" × 48"
TL642C, TL943C, TL1055C, TL1255C, TL1055D, TL1255D	2	60 mm × 125 mm × 1220 mm	2.36" × 5" × 48"
TH306D, TH406C, TH407C, TH3510D, TH514C, TL642C, TL943C, TL1055C, TL1255C, TL1055D, TL1255D	2	60 mm × 150 mm × 1525 mm	2.36" × 6" × 60"

---

**Block**

---

Model	Forks/Sets	Size	
TH255C, TH306D, TH336C, TH337C, TH406C, TH407C, TH3510D, TH414C, TH417C, TH514C, TL642C, TL943C, TL1055C, TL1255C, TL1055D, TL1255D	2	50 mm × 50 mm × 1220 mm	2" × 2" × 48"

---

**Lumber**

---

Model	Forks/Sets	Size	
TH255C	2	40 mm × 150 mm × 1525 mm	1.5" × 6" × 60"
TH306D, TH406C, TH407C, TH3510D, TH514C, TL642C, TL943C, TL1055C, TL1055D	2	45 mm × 180 mm × 1525 mm	1.75" × 7" × 60"
TH306D, TH3510D, TH514C, TL642C, TL943C, TL1055C, TL1055D	2	50 mm × 150 mm × 1829 mm	2" × 6" × 72"
TH306D, TH406C, TH407C, TH3510D, TL642C, TL943C, TL1055C, TL1255C, TL1055D, TL1255D	2	60 mm × 150 mm × 1525 mm	2.36" × 6" × 60"

**North American Models**

**Fork Type**

**Pallet**

Model	Forks/Sets	Size
TH306D, TH406C, TH407C, TH3510D	2	45 mm × 100 mm × 1067 mm 1.77" × 4" × 42"
TH306D, TH406C, TH407C, TH3510D	2	50 mm × 100 mm × 1525 mm 2" × 4" × 48"
TH306D, TH406C, TH407C, TH3510D	2	50 mm × 120 mm × 1200 mm 2" × 5" × 48"
TH306D, TH406C, TH407C, TH3510D	2	50 mm × 125 mm × 1220 mm 2" × 6" × 60"
TH255C, TH306D, TH406C, TH407C, TH3510D, TH514C	2	50 mm × 100 mm × 1220 mm 2" × 4" × 48"
TH306D, TH406C, TH407C, TH3510D, TH514C, TL642C, TL943C, TL1055C, TL642D, TL943D, TL1055D	2	60 mm × 100 mm × 1220 mm 2.36" × 4" × 48"
TL642C, TL943C, TL1055C, TL1255C, TL642D, TL943D, TL1055D, TL1255D	2	60 mm × 125 mm × 1220 mm 2.36" × 5" × 48"
TH406C, TH407C, TH3510D, TH514C, TL642C, TL943C, TL1055D, TL1255D	2	60 mm × 150 mm × 1525 mm 2.36" × 6" × 60"

**Block**

Model	Forks/Sets	Size
TH255C, TH306D, TH406C, TH407C, TH3510D, TH514C, TL642C, TL943C, TL1055C, TL1255C, TL1055D, TL1255D	2	50 mm × 50 mm × 1220 mm 2" × 2" × 48"

**Lumber**

Model	Forks/Sets	Size
TH255C	2	40 mm × 150 mm × 1525 mm 1.5" × 6" × 60"
TH306D, TH406C, TH407C, TH3510D, TL642C, TL943C, TL1055C, TL1055D	2	45 mm × 180 mm × 1525 mm 1.75" × 7" × 60"
TH406C, TH407C, TH3510D, TH514C, TL642C, TL943C, TL1055C, TL1255C, TL1055D, TL1255D	2	50 mm × 150 mm × 1829 mm 2" × 6" × 72"
TH406C, TH407C, TH3510D, TL642C, TL943C, TL1055C, TL1255C, TL642D, TL943D, TL1055D, TL1255D	2	60 mm × 150 mm × 1525 mm 2.36" × 6" × 60"

**Work Tools**

<b>Truss Boom</b>			<b>General Purpose Buckets</b>		
Capacity	500 kg	<b>1100 lb</b>	<b>0.75 m<sup>3</sup> (0.98 yd<sup>3</sup>)</b>	Capacity	0.75 m <sup>3</sup> <b>0.98 yd<sup>3</sup></b>
Width	850 mm	<b>34"</b>	Capacity	1880 mm	<b>74"</b>
Length	4 m	<b>13'1"</b>	Weight	393 kg	<b>867 lb</b>
<b>Lifting Hook, Fork Mounted</b>			<b>0.76 m<sup>3</sup> (1.0 yd<sup>3</sup>)</b>	Capacity	0.76 m <sup>3</sup> <b>1.0 yd<sup>3</sup></b>
Capacity	5443 kg	<b>12,000 lb</b>	Capacity	1854 mm	<b>73"</b>
Width	1168 mm	<b>46"</b>	Weight	322 kg	<b>710 lb</b>
Weight	159 kg	<b>350 lb</b>	<b>1.0 m<sup>3</sup> (1.3 yd<sup>3</sup>)</b>	Capacity	1.0 m <sup>3</sup> <b>1.3 yd<sup>3</sup></b>
Length	800 mm	<b>31.5"</b>	Capacity	2418 mm	<b>95"</b>
<b>Lifting Hook, IT</b>			Weight	457 kg	<b>1007 lb</b>
Capacity	4536 kg	<b>10,000 lb</b>	<b>1.3 m<sup>3</sup> (1.75 yd<sup>3</sup>)</b>	Capacity	1.3 m <sup>3</sup> <b>1.75 yd<sup>3</sup></b>
Width	697 mm	<b>28"</b>	Capacity	2445 mm	<b>96"</b>
Weight	98 kg	<b>216 lb</b>	Width	509 kg	<b>1122 lb</b>
Length	500 mm	<b>20"</b>	Weight		
<b>Manure Fork + Grab</b>			<b>1.3 m<sup>3</sup> (1.75 yd<sup>3</sup>)</b>	Capacity	1.3 m <sup>3</sup> <b>1.75 yd<sup>3</sup></b>
Capacity	1.8 m <sup>3</sup>	<b>2.34 yd<sup>3</sup></b>	Capacity	2445 mm	<b>96"</b>
Width	2290 mm	<b>90"</b>	Width	509 kg	<b>1122 lb</b>
Weight	560 kg	<b>1234 lb</b>	<b>Grapple Bucket</b>		
Tine length	1060 mm	<b>42"</b>	<b>0.76 m<sup>3</sup> (1.0 yd<sup>3</sup>)</b>	Capacity	0.76 m <sup>3</sup> <b>1.0 yd<sup>3</sup></b>
No. of tines		<b>9</b>	Capacity	1854 mm	<b>73"</b>
<b>Material Handling Arm</b>			Weight	497 kg	<b>1096 lb</b>
<b>2135 mm (84")</b>			<b>Light Material Buckets</b>		
Length	2135 mm	<b>84"</b>	<b>1.3 m<sup>3</sup> (1.7 yd<sup>3</sup>)</b>	Capacity	1.3 m <sup>3</sup> <b>1.7 yd<sup>3</sup></b>
Weight	127 kg	<b>280 lb</b>	Capacity	1829 mm	<b>72"</b>
<b>4162 mm (164")</b>			Width	348 kg	<b>768 lb</b>
Length	4162 mm	<b>164"</b>	Weight		
Weight	449 kg	<b>990 lb</b>	<b>2.0 m<sup>3</sup> (2.6 yd<sup>3</sup>)</b>	Capacity	2.0 m <sup>3</sup> <b>2.6 yd<sup>3</sup></b>
<b>Winch</b>			Capacity	2500 mm	<b>98"</b>
<b>1360 kg (3000 lb)</b>			Width	457 kg	<b>1007 lb</b>
Capacity	1360 kg	<b>3000 lb</b>	Weight		
Width	23 m	<b>75 ft</b>	<b>2.5 m<sup>3</sup> (3.25 yd<sup>3</sup>)</b>	Capacity	2.5 m <sup>3</sup> <b>3.25 yd<sup>3</sup></b>
<b>2722 kg (6000 lb)</b>			Capacity	2500 mm	<b>98"</b>
Capacity	2722 kg	<b>6000 lb</b>	Width	526 kg	<b>1159 lb</b>
Width	46 m	<b>150 ft</b>	Weight		
<b>Work Platform, Fork Mounted</b>			<b>3.0 m<sup>3</sup> (3.9 yd<sup>3</sup>)</b>	Capacity	3.0 m <sup>3</sup> <b>3.9 yd<sup>3</sup></b>
<b>1219 mm (48")</b>			Capacity	2700 mm	<b>106"</b>
Capacity	970 kg	<b>2000 lb</b>	Width	599 kg	<b>1320 lb</b>
Width	1219 mm	<b>48"</b>	Weight		
Height	2438 mm	<b>96"</b>	<b>Work Platform, Fork Mounted</b>		
<b>2438 mm (96")</b>			<b>1219 mm (48")</b>		
Capacity	970 kg	<b>2000 lb</b>	Capacity	970 kg	<b>2000 lb</b>
Width	2438 mm	<b>96"</b>	Width	2438 mm	<b>96"</b>
Height	1219 mm	<b>48"</b>	Height	1219 mm	<b>48"</b>

## Work Tools

<b>Material Handling Bucket</b>		
<b>1.5 m<sup>3</sup> (1.96 yd<sup>3</sup>)</b>		
Capacity	1.5 m <sup>3</sup>	<b>1.96 yd<sup>3</sup></b>
Width	2418 mm	<b>95"</b>
Weight	480 kg	<b>1058 lb</b>
<b>Multi-Grapple Bucket</b>		
<b>0.85 m<sup>3</sup> (1.11 yd<sup>3</sup>)</b>		
Capacity	0.85 m <sup>3</sup>	<b>1.11 yd<sup>3</sup></b>
Width	1854 mm	<b>73"</b>
Weight	630 kg	<b>1389 lb</b>

<b>Multi-Purpose Buckets</b>		
<b>0.37 m<sup>3</sup> (0.48 yd<sup>3</sup>)</b>		
Capacity	0.37 m <sup>3</sup>	<b>0.48 yd<sup>3</sup></b>
Width	1829 mm	<b>72"</b>
Weight	410 kg	<b>905 lb</b>
<b>1.0 m<sup>3</sup> (1.3 yd<sup>3</sup>)</b>		
Capacity	1.0 m <sup>3</sup>	<b>1.3 yd<sup>3</sup></b>
Width	2418 mm	<b>95"</b>
Weight	765 kg	<b>1687 lb</b>

# Telescopic Handlers

## Compatibility ● Non-U.S. Models

	TH255C	TH336C	TH337C	TH406C	TH407C	TH414C	TH417C	TH514C	TL642C	TL943C	TL642D	TL943D	TL1055D	TL1255D
Lifting Hook, Fork Mounted 321-0556	N/A	N/A	N/A	N/A	N/A	N/A	N/A	N/A	Yes	Yes	Yes	Yes	Yes	Yes
Lifting Hook, IT 169-6460	N/A	Yes	Yes	Yes	Yes	Yes	Yes	Yes	Yes	Yes	Yes	Yes	Yes	Yes
Manure Fork + Grab 2286 mm (90") 186-6054	N/A	Yes	Yes	Yes	Yes	N/A	N/A	N/A	N/A	N/A	N/A	N/A	N/A	N/A
Material Handling Arm 229-9714/216-8756	N/A	Yes	Yes	Yes	Yes	Yes	Yes	Yes	Yes	Yes	Yes	Yes	Yes	Yes
Truss Boom 169-3945	N/A	Yes	Yes	Yes	Yes	Yes	Yes	Yes	Yes	Yes	Yes	Yes	Yes	Yes
Work Platform, Fork Mounted 343-9739/9738	N/A	N/A	N/A	N/A	N/A	N/A	N/A	N/A	Yes	Yes	Yes	Yes	Yes	Yes
Standard Tilt Carriage 1220 mm (48") 350-9099/326-2013/2014	Yes	Yes	Yes	Yes	Yes	Yes	Yes	Yes	N/A	N/A	N/A	N/A	N/A	N/A
Standard Tilt Carriage 1270 mm (50") 301-9757	N/A	N/A	N/A	N/A	N/A	N/A	N/A	N/A	Yes	Yes	Yes	Yes	Yes	Yes
Standard Rotate/Tilt Carriage 1220 mm (48") 331-3251/231-3229	N/A	Yes	Yes	Yes	Yes	Yes	Yes	Yes	N/A	N/A	N/A	N/A	N/A	N/A
Standard Rotate/Tilt Carriage 1270 mm (50") 309-4315	N/A	N/A	N/A	N/A	N/A	N/A	N/A	N/A	Yes	Yes	Yes	Yes	Yes	Yes
Sideshift Carriage 1220 mm (48") 314-8479/222-6210/331-3252	N/A	Yes	Yes	Yes	Yes	Yes	Yes	Yes	Yes	Yes	Yes	Yes	Yes	Yes
Swing Carriage, 100°, 1829 mm (72") 318-9222	N/A	N/A	N/A	N/A	N/A	N/A	N/A	N/A	Yes	Yes	Yes	Yes	Yes	Yes
Swing Carriage, 180°, 1829 mm (72") 341-3591	N/A	N/A	N/A	N/A	N/A	N/A	N/A	N/A	N/A	N/A	N/A	N/A	N/A	Yes
Wide Rotate/Side Tilt Carriage 1829 mm (72") 309-4316/227-5748	N/A	Yes	Yes	Yes	Yes	Yes	Yes	Yes	Yes	Yes	Yes	Yes	Yes	Yes
Wide Tilt Carriage 1829 mm (72") 301-9758/174-7731	N/A	Yes	Yes	Yes	Yes	Yes	Yes	Yes	Yes	Yes	Yes	Yes	Yes	Yes
<b>General Purpose Bucket:</b>														
0.75 m <sup>3</sup> (0.98 yd <sup>3</sup> ) 207-5154	Yes	N/A	N/A	N/A	N/A	N/A	N/A	N/A	N/A	N/A	N/A	N/A	N/A	N/A
0.76 m <sup>3</sup> (1.0 yd <sup>3</sup> ) 330-4237	N/A	N/A	N/A	N/A	N/A	N/A	N/A	N/A	N/A	N/A	N/A	N/A	N/A	N/A
1.0 m <sup>3</sup> (1.3 yd <sup>3</sup> ) 163-4261	N/A	Yes	Yes	Yes	Yes	Yes	Yes	Yes	Yes	Yes	Yes	Yes	Yes	Yes
1.3 m <sup>3</sup> (1.75 yd <sup>3</sup> ) 194-2564/2563	N/A	N/A	N/A	N/A	N/A	N/A	N/A	N/A	Yes	Yes	Yes	Yes	Yes	Yes
<b>Grapple Bucket:</b>														
0.85 m <sup>3</sup> (1.1 yd <sup>3</sup> ) 461-7032	N/A	Yes	Yes	Yes	Yes	Yes	N/A	Yes	N/A	N/A	N/A	N/A	N/A	N/A
<b>Light Material Bucket:</b>														
0.8 m <sup>3</sup> (1.05 yd <sup>3</sup> ) 350-0505	Yes	N/A	N/A	N/A	N/A	N/A	N/A	N/A	N/A	N/A	N/A	N/A	N/A	N/A
1.3 m <sup>3</sup> (1.7 yd <sup>3</sup> ) 330-4236	N/A	N/A	N/A	N/A	N/A	N/A	N/A	N/A	N/A	N/A	N/A	N/A	N/A	N/A
2.0 m <sup>3</sup> (2.6 yd <sup>3</sup> ) 220-4759	N/A	Yes	Yes	Yes	Yes	N/A	N/A	N/A	N/A	N/A	N/A	N/A	N/A	N/A
2.5 m <sup>3</sup> (3.25 yd <sup>3</sup> ) 220-4670	N/A	Yes	Yes	Yes	Yes	N/A	N/A	N/A	N/A	N/A	N/A	N/A	N/A	N/A
3.0 m <sup>3</sup> (3.9 yd <sup>3</sup> ) 220-4761	N/A	Yes	Yes	Yes	Yes	N/A	N/A	N/A	N/A	N/A	N/A	N/A	N/A	N/A
<b>Material Handling Bucket:</b>														
1.5 m <sup>3</sup> (1.96 yd <sup>3</sup> ) 186-5838	N/A	N/A	N/A	Yes	Yes	Yes	N/A	N/A	Yes	Yes	Yes	Yes	Yes	Yes
<b>Multi-Grapple Bucket:</b>														
0.85 m <sup>3</sup> (1.11 yd <sup>3</sup> ) 219-5515	N/A	N/A	N/A	N/A	N/A	N/A	N/A	N/A	N/A	N/A	N/A	N/A	N/A	N/A
<b>Multi-Purpose Bucket:</b>														
0.37 m <sup>3</sup> (0.48 yd <sup>3</sup> ) 279-5399	N/A	N/A	N/A	N/A	N/A	N/A	N/A	N/A	N/A	N/A	N/A	N/A	N/A	N/A
1.0 m <sup>3</sup> (1.3 yd <sup>3</sup> ) 163-4265	N/A	Yes	Yes	Yes	Yes	Yes	N/A	N/A	Yes	Yes	Yes	Yes	Yes	Yes

	TH255C	TH336C	TH337C	TH406C	TH407C	TH414C	TH417C	TH514C	TL642C	TL943C	TL642D	TL943D	TL1055D	TL1255D
<b>Pallet Fork — 45 mm (1.77") Diameter:</b> 1067 mm (42") x 100 mm (4") 252-1454	Yes	Yes	Yes	Yes	Yes	Yes	Yes	N/A	N/A	N/A	N/A	N/A	N/A	N/A
<b>Pallet Fork — 51 mm (2") Diameter:</b> 1200 mm (47") x 100 mm (4") 309-9179/326-1997	Yes	Yes	Yes	Yes	Yes	Yes	Yes	N/A	N/A	N/A	N/A	N/A	N/A	N/A
1200 mm (47") x 125 mm (5") 364-5356	Yes	Yes	Yes	Yes	Yes	Yes	Yes	Yes	N/A	N/A	N/A	N/A	N/A	N/A
1220 mm (48") x 100 mm (4") 323-5738/252-1455	Yes	N/A	N/A	Yes	Yes	N/A	N/A	Yes	N/A	N/A	N/A	N/A	N/A	N/A
1220 mm (48") x 125 mm (5") 252-1459	N/A	N/A	N/A	Yes	Yes	N/A	N/A	Yes	N/A	N/A	N/A	N/A	N/A	N/A
1525 mm (60") x 100 mm (4") 252-1456	Yes	Yes	Yes	Yes	Yes	Yes	Yes	N/A	N/A	N/A	N/A	N/A	N/A	N/A
<b>Pallet Fork — 60 mm (2.36") Diameter:</b> 1220 mm (48") x 100 mm (4") 301-9755/326-1998	N/A	Yes	Yes	Yes	Yes	Yes	Yes	Yes	Yes	Yes	Yes	Yes	Yes	N/A
1220 mm (48") x 125 mm (5") 301-9753	N/A	N/A	N/A	N/A	N/A	N/A	N/A	N/A	Yes	Yes	Yes	Yes	Yes	Yes
1525 mm (60") x 150 mm (6") 301-9754	N/A	N/A	N/A	Yes	Yes	N/A	N/A	Yes	Yes	Yes	Yes	Yes	Yes	Yes
<b>Block Fork — 50 mm (2") Diameter:</b> 1220 mm (48") x 50 mm (2") 252-1460	Yes	Yes	Yes	Yes	Yes	Yes	Yes	Yes	Yes	Yes	Yes	Yes	Yes	Yes
<b>Lumber Fork — 38 mm (1.5") Diameter:</b> 1525 mm (60") x 150 mm (6") 323-5737	Yes	N/A	N/A	N/A	N/A	N/A	N/A	N/A	N/A	N/A	N/A	N/A	N/A	N/A
<b>Lumber Fork — 45 mm (1.75") Diameter:</b> 1525 mm (60") x 180 mm (7") 301-9756	N/A	N/A	N/A	Yes	Yes	N/A	N/A	N/A	Yes	Yes	Yes	Yes	Yes	N/A
<b>Lumber Fork — 50 mm (2") Diameter:</b> 1829 mm (72") x 150 mm (6") 311-2854	N/A	N/A	N/A	Yes	Yes	N/A	N/A	Yes	Yes	Yes	Yes	Yes	Yes	Yes
<b>Lumber Fork — 60 mm (2.36") Diameter:</b> 1525 mm (60") x 150 mm (6") 301-9754	N/A	N/A	N/A	Yes	Yes	N/A	N/A	N/A	Yes	Yes	Yes	Yes	Yes	Yes
<b>Winch:</b> 23 m (75 ft) 305-3773	N/A	N/A	N/A	N/A	N/A	N/A	N/A	N/A	Yes	Yes	Yes	Yes	Yes	Yes
46 m (150 ft) 305-3768	N/A	N/A	N/A	N/A	N/A	N/A	N/A	N/A	Yes	Yes	Yes	Yes	N/A	N/A

	TH255C	TH406C	TH407C	TH514C	TL642C	TL943C	TL1055C	TL1255C	TL642D	TL943D	TL1055D	TL1255D
Lifting Hook, Fork Mounted 321-0556	Yes	Yes	Yes	Yes	Yes	Yes	Yes	Yes	Yes	Yes	Yes	Yes
Lifting Hook, IT 169-6460	N/A	Yes	Yes	Yes	Yes	Yes	Yes	Yes	Yes	Yes	Yes	Yes
Manure Fork + Grab 2286 mm (90") 186-6054	N/A	Yes	Yes	N/A	N/A	N/A	N/A	N/A	N/A	N/A	N/A	N/A
Material Handling Arm	Yes	N/A	N/A	Yes	Yes	Yes	Yes	Yes	Yes	Yes	Yes	Yes
Truss Boom 169-3945	N/A	Yes	Yes	Yes	Yes	Yes	Yes	Yes	Yes	Yes	Yes	Yes
Work Platform, Fork Mounted 343-9739/9738	N/A	Yes	Yes	Yes	Yes	Yes	Yes	Yes	Yes	Yes	Yes	Yes
Standard Tilt Carriage 1220 mm (48") 350-9099	Yes	N/A	N/A	N/A	N/A	N/A	N/A	N/A	N/A	N/A	N/A	N/A
Standard Tilt Carriage 1270 mm (50") 301-9757	N/A	Yes	Yes	Yes	Yes	Yes	Yes	Yes	Yes	Yes	Yes	Yes
Standard Rotate/Tilt Carriage 1220 mm (48") 331-3251	Yes	N/A	N/A	N/A	N/A	N/A	N/A	N/A	N/A	N/A	N/A	N/A
Standard Rotate/Tilt Carriage 1270 mm (50") 309-4315	N/A	Yes	Yes	Yes	Yes	Yes	Yes	Yes	Yes	Yes	Yes	Yes
Sideshift Carriage 1220 mm (48") 314-8479/222-6210/331-3252	Yes	Yes	Yes	Yes	Yes	Yes	Yes	Yes	Yes	Yes	Yes	Yes
Swing Carriage, 100°, 1829 mm (72") 318-9222	N/A	Yes	Yes	Yes	Yes	Yes	Yes	Yes	Yes	Yes	Yes	Yes
Swing Carriage, 180°, 1829 mm (72") 341-3591	N/A	N/A	N/A	N/A	N/A	N/A	N/A	Yes	N/A	N/A	N/A	Yes
Wide Rotate/Side Tilt Carriage 1829 mm (72") 309-4316	N/A	Yes	Yes	Yes	Yes	Yes	Yes	Yes	Yes	Yes	Yes	Yes
Wide Tilt Carriage 1829 mm (72") 301-9758	N/A	Yes	Yes	Yes	Yes	Yes	Yes	Yes	Yes	Yes	Yes	Yes
<b>General Purpose Bucket:</b>												
0.75 m <sup>3</sup> (0.98 yd <sup>3</sup> ) 207-5154	Yes	N/A	N/A	N/A	N/A	N/A	N/A	N/A	N/A	N/A	N/A	N/A
0.76 m <sup>3</sup> (1.0 yd <sup>3</sup> ) 330-4237	Yes	N/A	N/A	N/A	N/A	N/A	N/A	N/A	N/A	N/A	N/A	N/A
1.0 m <sup>3</sup> (1.3 yd <sup>3</sup> ) 163-4261	N/A	Yes	Yes	Yes	Yes	Yes	Yes	Yes	Yes	Yes	Yes	Yes
1.3 m <sup>3</sup> (1.75 yd <sup>3</sup> ) 194-2564/2563	N/A	Yes	Yes	Yes	Yes	Yes	Yes	Yes	Yes	Yes	Yes	Yes
<b>Grapple Bucket:</b>												
0.76 m <sup>3</sup> (1.0 yd <sup>3</sup> ) 330-4240/158-6095/157-7225	Yes	N/A	N/A	N/A	N/A	N/A	N/A	N/A	N/A	N/A	N/A	N/A
<b>Light Material Bucket:</b>												
1.3 m <sup>3</sup> (1.7 yd <sup>3</sup> ) 330-4236	Yes	N/A	N/A	N/A	N/A	N/A	N/A	N/A	N/A	N/A	N/A	N/A
2.0 m <sup>3</sup> (2.6 yd <sup>3</sup> ) 220-4759	N/A	Yes	Yes	N/A	N/A	N/A	N/A	N/A	N/A	N/A	N/A	N/A
2.5 m <sup>3</sup> (3.25 yd <sup>3</sup> ) 220-4670	N/A	Yes	Yes	N/A	N/A	N/A	N/A	N/A	N/A	N/A	N/A	N/A
3.0 m <sup>3</sup> (3.9 yd <sup>3</sup> ) 220-4761	N/A	Yes	Yes	N/A	N/A	N/A	N/A	N/A	N/A	N/A	N/A	N/A
<b>Material Handling Bucket:</b>												
1.5 m <sup>3</sup> (1.96 yd <sup>3</sup> ) 186-5838	N/A	Yes	Yes	Yes	Yes	Yes	Yes	Yes	Yes	Yes	Yes	Yes
<b>Multi-Grapple Bucket:</b>												
0.85 m <sup>3</sup> (1.11 yd <sup>3</sup> ) 219-5515	N/A	Yes	Yes	N/A	N/A	N/A	N/A	N/A	N/A	N/A	N/A	N/A
<b>Multi-Purpose Bucket:</b>												
0.37 m <sup>3</sup> (0.48 yd <sup>3</sup> ) 279-5399	Yes	N/A	N/A	N/A	N/A	N/A	N/A	N/A	N/A	N/A	N/A	N/A
1.0 m <sup>3</sup> (1.3 yd <sup>3</sup> ) 163-4265	N/A	Yes	Yes	N/A	Yes	Yes	Yes	Yes	Yes	Yes	Yes	Yes

	TH255C	TH406C	TH407C	TH514C	TL642C	TL943C	TL1055C	TL1255C	TL642D	TL943D	TL1055D	TL1255D
<b>Pallet Fork — 45 mm (1.77") Diameter:</b> 1067 mm (42") × 100 mm (4") 252-1454	N/A	Yes	Yes	N/A	N/A	N/A	N/A	N/A	N/A	N/A	N/A	N/A
<b>Pallet Fork — 51 mm (2") Diameter:</b> 1200 mm (47") × 125 mm (5") 364-5356	N/A	Yes	Yes	N/A	N/A	N/A	N/A	N/A	N/A	N/A	N/A	N/A
1220 mm (48") × 100 mm (4") 323-5738/252-1455	Yes	Yes	Yes	Yes	N/A	N/A	N/A	N/A	N/A	N/A	N/A	N/A
1220 mm (48") × 125 mm (5") 252-1459	N/A	Yes	Yes	N/A	N/A	N/A	N/A	N/A	N/A	N/A	N/A	N/A
1525 mm (60") × 100 mm (4") 252-1456/326-1997	N/A	Yes	Yes	N/A	N/A	N/A	N/A	N/A	N/A	N/A	N/A	N/A
<b>Pallet Fork — 60 mm (2.36") Diameter:</b> 1220 mm (48") × 100 mm (4") 301-9755/326-1998	N/A	Yes	Yes	Yes	Yes	Yes	Yes	N/A	Yes	Yes	Yes	N/A
1220 mm (48") × 125 mm (5") 301-9753	N/A	N/A	N/A	N/A	Yes	Yes	Yes	Yes	Yes	Yes	Yes	Yes
1525 mm (60") × 150 mm (6") 301-9754	N/A	Yes	Yes	Yes	Yes	Yes	Yes	Yes	Yes	Yes	Yes	Yes
<b>Block Fork — 50 mm (2") Diameter:</b> 1220 mm (48") × 50 mm (2") 252-1460/301-9752	Yes	Yes	Yes	Yes	Yes	Yes	Yes	Yes	Yes	Yes	Yes	Yes
<b>Lumber Fork — 38 mm (1.5") Diameter:</b> 1525 mm (60") × 150 mm (6") 323-5737	Yes	N/A	N/A	N/A	N/A	N/A	N/A	N/A	N/A	N/A	N/A	N/A
<b>Lumber Fork — 45 mm (1.75") Diameter:</b> 1525 mm (60") × 180 mm (7") 301-9756	N/A	Yes	Yes	N/A	Yes	Yes	Yes	N/A	Yes	Yes	Yes	N/A
<b>Lumber Fork — 50 mm (2") Diameter:</b> 1829 mm (72") × 150 mm (6") 311-2854	N/A	Yes	Yes	Yes	Yes	Yes	Yes	Yes	Yes	Yes	Yes	Yes
<b>Lumber Fork — 60 mm (2.36") Diameter:</b> 1525 mm (60") × 150 mm (6") 301-9754	N/A	Yes	Yes	N/A	Yes	Yes	Yes	Yes	Yes	Yes	Yes	Yes
<b>Winch:</b> 23 m (75 ft) 305-3773	N/A	N/A	N/A	N/A	Yes	Yes	Yes	Yes	Yes	Yes	Yes	Yes
46 m (150 ft) 305-3768	N/A	N/A	N/A	N/A	Yes	Yes	N/A	N/A	Yes	Yes	N/A	N/A





# TRACK LOADERS

## CONTENTS

Features . . . . .	18-1
Special Arrangements . . . . .	18-7
Specifications . . . . .	18-8
Performance Data . . . . .	18-10
Machine Dimensions with General Purpose Bucket . . . . .	18-22
Machine Dimensions with Multi-Purpose Bucket . . . . .	18-24
Rippers/Scarifiers . . . . .	18-25
Drawbar Curves . . . . .	18-26
Extreme Slope Operation . . . . .	18-27
SAE Loader Ratings . . . . .	18-28
Estimating Cycle Time . . . . .	18-29
Bucket Fill Factors . . . . .	18-30
Recommended Operating Capacities . . . . .	18-30
Loader Production . . . . .	18-30
Estimating Bucket Load . . . . .	18-30
Estimating Production . . . . .	18-31
Alternative Machine Selection Method . . . . .	18-31
Production and Machine Selection: Nomographs . . . . .	18-32
Travel Time Charts . . . . .	18-34
Production Estimating Table . . . . .	18-35
Work Tools . . . . .	18-36
Shoe Options . . . . .	18-38

## Features common to all D Series models (953D-963D-973D):

- **Improved serviceability.** All D Series Track-Type Loaders are equipped with a tiltable cab that allows complete service of the hydraulic system. Most daily maintenance checks are performed from the machine's right side, facilitating quick start up. Easy access to major components enhances serviceability and increase uptime.
- **Operator station.** Experience a high level of efficiency, comfort and productivity with the new D Series cab. The cab features a new gauge cluster, a fully air-suspension seat, the new seat mounted controls, an automatic air climate control and provides excellent visibility.
- **Messenger.** Messenger is a new electronic monitoring system with real time, visual feedback on engine and machine operating conditions. It provides information on diagnostic data, maintenance, and allows operating settings such as implement reactions.
- **Hydrostatic drive.** The closed loop hydrostatic drive with electronic control provides precise modulation for quick, smooth operation and superior maneuverability. Shorter cycle times, high efficiency, and excellent maneuverability results in increased productivity.

**Features common to all D Series models (953D-963D-973D) (continued):**

- **Steering controls.** All D Series Track Loaders are offered with a choice of either the traditional V-lever with pedal steering or joystick control. With joystick control both steering and transmission functions are managed using the joystick. The joystick handles includes three buttons. The yellow buttons are used to increase/decrease the travel speed of the machine. The black button activates the horn. There are four different settings for both forward and reverse with the speed displayed on the multifunctional dashboard. This pattern is commonly referred to as S-pattern steering. All Cat® D Series Track-Type Loaders (953D – 963D – 973D) provide the option of two different transmission control joystick configurations. All machines ship from the factory with the default S-Pattern like a Cat Skid Steer Loader. After the machine arrives at the dealership, it can be changed to C-Pattern by the Cat Electronic Technician service tool if required.
- **Electro-hydraulic implements controls.** The new electro-hydraulic implement controls provide the operator with responsive, smooth and precise control of bucket and lift arms.
- **Kickout settings.** Automatic kickouts are part of the electro-hydraulic controls; adjust from inside the cab with a simple rocker switch. Kickout stops are hydraulically cushioned for greater operator comfort and less material spillage.
- **Position Sensing Cylinder.** The D Series has electro-hydraulic implement controls for lower operator effort. The new position sensing cylinders allow setting detents at any positions from the cab. They feature also a load sensing implement pump which reduces engine power consumption.
- **Hydraulic on-demand fan.** The fan is a hydraulic demand type one with optional reversible function, operating in sucker mode. It gives the best efficiency and avoids also sucking the dust and debris coming from the outside into the cooling package.
- **Oscillating track roller frames** decrease ground shock, increase machine stability and improve traction.
- **Unmatched versatility** – excavates, loads, dozes, grades, clears, strips, backfills in all underfoot conditions including those that could damage tires.
- **Sound-suppressed, air-pressurized, resiliently mounted ROPS cab** for superior working environment.
- **Sealed loader linkage** extends lubrication intervals and reduces maintenance time.
- **Automatic bucket controls** let bucket rise to pre-set dumping height and return to pre-set digging angle for fast cycle time.
- **General Purpose and Multi-Purpose** buckets, quick couplers and many other work tools are available to increase versatility.
- **Rippers** are Multishank with wide beam coverage for utility ripping close to walls, footings and embankments. Three shanks are available for D Series Track Loaders.
- **Product Link™ System** reports machine location and hours and consequently makes the maintenance easier and reduces the downtime. Please check availability with your local dealer.
- **Cat Machine Security System** allows better machine protection by preventing theft. A microchip is embedded in the key to provide more security. Cat Machine Security System is an optional feature.
- **K System** is a Caterpillar exclusive which allows ease of installation and removal. New adapters provide better performance and offer a longer lasting life than J Series (+30%).
- **Special Application Arrangements.** Special arrangements — Waste Handling, Demolition, Wide Gauge and more, are available or can be designed on request, to allow the D Series to work in special applications.

**Features of 953D-963D:**

- **C6.6 ACERT™ Engine.** The Cat C6.6 ACERT engine utilizes the Cat Common Rail fuel delivery system. Designed for performance, durability, serviceability, and fuel economy, it meets U.S. EPA Tier 3, EU Stage IIIA and Japan 2006 (Tier 3) equivalent emission standards.
- **SystemOne™ Moving U/C.** The revolutionary Cat SystemOne Undercarriage provides maximum undercarriage life and reliability no matter the application, environment or underfoot conditions. Built to last longer and require less maintenance it ensures a dramatic drop in owning and operating costs.
- **Special Application Arrangements.** Ship Hold Arrangements are available on 953D-963D.

**Features of 973D:**

- **C9 ACERT Engine.** The Cat C9 ACERT engine is an 8.8 liter (537 in<sup>3</sup>) displacement, six-cylinder, in-line configured engine with hydraulically actuated electronic fuel injection or HEUI™. The 196 kW (263 hp) rated net power engine meets U.S. EPA Tier 3, EU Stage IIIA and Japan 2006 (Tier 3) equivalent emission standards.
- **Rear engine location** provides natural stability as a “working” counterweight, excellent visibility and good weight to horsepower ratio.
- **Electronic hydrostatic drive train with pedal steering** offers independent control of each track. Power turns, counterrotation infinitely variable speeds, and fast acceleration for increased maneuverability and production.
- **Variable displacement pump and motors** provide excellent efficiency and controllability.
- **Z-bar linkage** provides increased breakout force, fewer grease points and fast dump speed.
- **Special arrangements** including Wide Gauge, Waste Handling, Ship Hold, Tunneling and Steel Mill are available to tailor the machine to specific applications.
- **Special Application Arrangements.** The steel mill arrangement protects the 973D and its operator against extreme conditions to allow the machine to handle hot slag in steel mill operations. The special arrangement features additional guarding for critical components, sealed undercarriage, heat shields for fuel tank, power train and hydraulics, silicone seals and heat resistant windshield, remote parking brake release and fire-resistant fluids. The Steel Mill Arrangement provides the best protection available for this extremely difficult application.

**Features of 953K-963K:**

- **Fuel efficiency.** A more fuel efficient Cat C7.1 ACERT engine and Eco Mode combine to give you a 10-30 percent reduction in fuel use.\*
- **Performance.** Smarter power train management gives you power when you need it and improved implement and steering response.\*
- **Ease of operation.** Cab updates offer added comfort and convenience for operators. New handles and steps make access/egress even easier from the front or the back of the tracks.
- **Technology.** Remote monitoring with Product Link/VisionLink® helps you manage your fleet more effectively and profitably.
- **Engine.** A Cat C7.1 ACERT engine gives you the power and reliability you need to get the job done. The engine is equipped with a twin turbo, providing faster machine response under load.
- **Fuel efficiency/Eco Mode.** The more efficient engine and an Eco Mode combine to deliver a 10-30 percent reduction in fuel consumption compared to the 963D. Eco Mode automatically reduces engine speed, but maintains selected ground speed under lighter loads. Efficient use of Diesel Exhaust Fluid (DEF) — typically 2.5-3 percent of fuel consumption — provides excellent overall fluid efficiency.

\*Compared to the 953D or 963D.

- **Hydrostatic drive.** A new Electronic Control Module gives you smarter power train management, resulting in smoother implement/steering response and improved steering performance over the previous model. Power reaches the ground more efficiently based on the demands of the application, giving you fast acceleration and shorter cycle times. The electronically controlled Hystat drive uses variable displacement pumps and drive motors to power each track independently, delivering fast acceleration and infinitely variable speed. The operator can command smooth machine turns and counterrotation.
- **Cooling system.** The single unit cooling system incorporates the radiator, air-to-air aftercooler, oil cooler and fan installation. The cooling module is located at the rear of the loader, away from dust and debris stirred up by the bucket while the machine is working. The radiator has 6.5 fins per inch to help reduce plugging. A simple, side-by-side design reduces debris and makes cleaning easier. The fold-down design gives you easy access.  
  
A hydraulic demand fan reduces speed in cooler conditions to conserve power, save fuel and decrease sound levels. An optional reversing fan is available for high debris conditions.
- **Load-sensing hydraulics.** Field-proven system senses the load and continuously adjusts hydraulic power to maximize your efficiency. Operators have precise control and the power needed for simultaneous lift, tilt and travel.

**Features of 953K-963K (continued):**

- **Position sensing cylinders.** Position sensing cylinders allow the operator to set lift and tilt kickouts to match the application without leaving the cab. Linkage position can be automatically set to specific positions for increased productivity. Advanced automatic features help make start/stop motions smoother, reducing vibration in the cab.
  - **Automatic kickouts.** Standard programmable automatic kickouts provide flexibility and productivity for precise load and dump target heights. Tilt and lift kickouts are easily set by positioning the bucket or attachment and pressing a button on the right-hand control panel in the cab.
  - **Implement and steering controls.** Electro-hydraulic implement controls provide the operator with responsive, smooth and precise control of bucket and lift arms.
    - Choose from either joystick or two-lever implement controls to match operator preference or application.
    - Speed/steering controls are available as either a joystick or as V-lever and foot pedals.
    - A variable throttle control dial lets you use preset engine speeds, customize engine speeds for operator preference.
    - Selectable electro-hydraulic maps and hydrostatic transmission allow you to set implement response — fine, normal, coarse — to match operator preference or application.
    - Hydrostatic drive system provides quick machine travel speed, on-the-go directional changes and counterrotation.
  - **Aftertreatment technologies.** With millions of working hours on tens of thousands of units since the Tier 4 Interim/Stage IIIB/Japan 2011 (Tier 4 Interim) product introductions, you can be confident in the quality and value of your Cat Tier 4 Final/Stage IV/Japan 2014 (Tier 4 Final) investment. To meet the reduction in NO<sub>x</sub> emissions required by Tier 4 Final/Stage IV/Japan 2014 (Tier 4 Final) emission standards, Caterpillar engineers added Selective Catalytic Reduction (SCR) to the already proven aftertreatment solution.
  - **Diesel Exhaust Fluid.** Selective Catalytic Reduction utilizes Diesel Exhaust Fluid (DEF), which can be conveniently refilled from ground level when you refuel. The system is designed to use one tank of DEF for each tank of fuel (1:1 DEF fill ratio). A gauge on the dash shows your fluid level. Across a variety of applications, the 963K typically has used DEF at a rate of 2.5-3 percent of fuel consumption. When the machine is turned off, a pump will automatically purge the DEF lines. A symbol on the dash and a light/symbol in the engine compartment indicate when the purge is complete and that it is safe to turn off the electrical disconnect. If the engine/aftertreatment temperatures are high, a Delayed Engine Shutdown will activate automatically to cool the machine and then purge the lines.
  - **Buckets.** A choice of buckets help you optimize your machine for the work you do. The General Purpose bucket is designed for excellent loadability and long life in applications like hard bank excavating, stripping and stockpile loading. The Multipurpose bucket is designed for versatility, and is ideal for a variety of tasks like loading, stripping, clearing, bulldozing, picking up debris and fine grading. The bucket clamps hydraulically to grip or handle other tough-to-grasp materials.
- A new optional Performance Series bucket contributes to your productivity by moving 5-10 percent more material per hour. And for special applications, Caterpillar also offers buckets optimized for applications like waste/landfill and ship hold work.

**Features of 953K-963K (continued):**

- **K Series™ bucket tooth tips.** The K Series tooth system stays sharp, holds tight and allows for simple changes. The lower-profile shape maintains optimal sharpness, penetration and digging ability throughout the tip life.
- **Quick coupler ready.** Fusion™ Quick Coupler option gives you more versatility by allowing easy use of forks, buckets, etc. from wheel loaders and other Fusion compatible machines.
- **Ripper.** The multi shank ripper adds extra versatility and force to expand the machine's range of applications. The ripper beam has three pockets for holding ripper shanks, and its design allows the machine to rip frozen ground, asphalt and even hard soils or rock. Long shanks deliver more work per pass making the machine more productive.
- **Safety.** New handles and steps help operators climb on and off the machine more easily, from the front or the back of the tracks.
  - Excellent visibility to the bucket and all around the machine helps operators work more confidently.
  - Rear vision camera is available to enhance visibility behind the machine.
  - New seat belt indicator gives an alarm and registers fault code through Product Link if the operator fails to buckle up, enhancing job site safety.
  - Improved ergonomics, a quieter engine and reduced effort controls help lessen fatigue so operators are better able to remain fresh and focused.
- **Serviceability.** The 963K is designed to help you take care of routine maintenance and get back to work.
  - Grouped service points are located behind large access doors, and daily grease points are in easy reach at ground level.
  - The tilt cab allows easy access to drive train and hydraulic systems.
  - The cooling system can be accessed from the engine compartment and features a fold-down fan for easy clean-out.
  - A handy bracket at the rear of the machine holds a shovel to help you clean the undercarriage.
  - The Diesel Particulate Filter in the Clean Emissions Module is designed to work for the life of the engine without needing to clean or replace the filter.
  - The service mode in the operator display shows you hydrostatic and implement pressure for easier troubleshooting and servicing.

**Special Arrangements of 953K and 963K:**

- **Waste Handler.** Designed and built from the frame up to take on the unique challenges of landfill and transfer station work.
  - Specialized guarding, striker bars and seals help protect the machine from impact and airborne debris.
  - Final drive guarding helps prevent wrapping and damage.
  - Cooling system is designed for high debris environments, with easy access for cleanout.
  - Specialized air handling features help deliver cleaner air to the machine and to the cab.
  - Landfill buckets and track options help you optimize your waste handler for the job.
- **Ship Hold/Port Handling.** Maneuverability, ease of operation and reach make a track loader the ideal machine for quickly removing materials from ship holds.
  - Sweep down walls and handle a wide variety of materials.
  - Specialized sealing, guards and bumpers help protect key components.
  - Added lighting packages help illuminate the work area.
  - Specialized implements, like coal buckets and trim blades, help you equip the machine for optimal performance.
  - Fusion Quick Coupler option gives you more versatility by allowing easy use of forks, buckets, etc. from wheel loaders and other Fusion compatible machines.
  - Lift eyes on the frame and undercarriage are widely spaced for stability during lifting.
- **Custom Products/Value Packages.** Caterpillar offers a variety of custom product options for track loaders, such as wide gauge machines and special guarding packages.



MODEL	953D		963D		973D	
Emission Standards	Tier 3, Stage IIIA, Japan 2006 (Tier 3) equivalent <sup>1</sup>		Tier 3, Stage IIIA, Japan 2006 (Tier 3) equivalent <sup>1</sup>		Tier 3, Stage IIIA, Japan 2006 (Tier 3) equivalent <sup>1</sup>	
Flywheel Power	110 kW	<b>148 hp</b>	141 kW	<b>189 hp</b>	196 kW	<b>263 hp</b>
Operating Weight*	15 517 kg	<b>34,209 lb</b>	20 220 kg	<b>44,577 lb</b>	28 058 kg	<b>61,857 lb</b>
Engine Model	<b>C6.6 ACERT</b>		<b>C6.6 ACERT</b>		<b>C9 ACERT</b>	
Rated Engine RPM	<b>2000</b>		<b>2000</b>		<b>1900</b>	
Bore	105 mm	<b>4"</b>	105 mm	<b>4.13"</b>	112 mm	<b>4.41"</b>
Stroke	127 mm	<b>5"</b>	127 mm	<b>5"</b>	149 mm	<b>5.87"</b>
No. Cylinders	<b>6</b>		<b>6</b>		<b>6</b>	
Displacement	6.6 L	<b>402.7 in<sup>3</sup></b>	6.6 L	<b>402.7 in<sup>3</sup></b>	8.8 L	<b>537 in<sup>3</sup></b>
Speeds Forward/Reverse	km/h	<b>mph</b>	km/h	<b>mph</b>	km/h	<b>mph</b>
1st	0-10	<b>0-6.2</b>	0-10	<b>0-6.2</b>	0-11	<b>0-6.8</b>
2nd	<b>Infinitely</b>		<b>Infinitely</b>		<b>Infinitely</b>	
3rd	<b>Variable</b>		<b>Variable</b>		<b>Variable</b>	
Hydraulic Cycle Time, Bucket Empty, in Seconds:						
Raise	<b>5.9</b>		<b>5.8</b>		<b>6.5</b>	
Dump	<b>1.5</b>		<b>1.3</b>		<b>1.4</b>	
Lower (Empty, Float Down)	<b>3.2</b>		<b>2.9</b>		<b>2.7</b>	
Track Rollers (Each Side)	<b>6</b>		<b>7</b>		<b>7</b>	
Width of Standard Track Shoe	480 mm	<b>19"</b>	550 mm	<b>21.6"</b>	550 mm	<b>21.7"</b>
Length of Track on Ground	2323 mm	<b>91.4"</b>	2543 mm	<b>100.1"</b>	2930 mm	<b>115"</b>
Ground Contact Area (with Standard Shoes)	2.3 m <sup>2</sup>	<b>3565 in<sup>2</sup></b>	2.8 m <sup>2</sup>	<b>4340 in<sup>2</sup></b>	3.22 m <sup>2</sup>	<b>4991 in<sup>2</sup></b>
Ground Pressure	65.5 kPa	<b>9.5 psi</b>	71.5 kPa	<b>10.3 psi</b>	85.5 kPa	<b>12.0 psi</b>
Ground Clearance	416 mm	<b>16.3"</b>	471 mm	<b>18.5"</b>	482 mm	<b>18.98"</b>
Track Gauge	1800 mm	<b>71"</b>	1850 mm	<b>72.8"</b>	2160 mm	<b>85"</b>
Width without Bucket (with Standard Shoes)	2280 mm	<b>89.7"</b>	2400 mm	<b>94.5"</b>	2710 mm	<b>106.7"</b>
Fuel Tank Refill Capacity	316 L	<b>83.5 U.S. gal</b>	400 L	<b>105.6 U.S. gal</b>	621 L**	<b>164.1 U.S. gal**</b>
Hydraulic System Refill Capacity	70 L	<b>18.5 U.S. gal</b>	90 L	<b>23.8 U.S. gal</b>	189 L	<b>49.9 U.S. gal</b>

\*953D and 963D weights include GP bucket with bolt-on adapters, long tips and segments.

\*\*Except for Steel Mill Arrangement — Fuel Tank Refill Capacity is 422 L (111.4 U.S. gal).

<sup>1</sup> Products available to meet Tier 2/Stage II/Japan 2001 (Tier 2) equivalent OR Tier 3/Stage IIIA/Japan 2006 (Tier 3) equivalent emission standards.

<b>MODEL</b>	<b>953K</b>		<b>963K</b>	
Emission Standards	<b>Tier 4 Final/Stage IV/Japan 2014 (Tier 4 Final)/Korea Tier 4 Final</b>		<b>Tier 4 Final/Stage IV/Japan 2014 (Tier 4 Final)/Korea Tier 4 Final</b>	
Flywheel Power	115 kW	<b>154 hp</b>	144 kW	<b>193 hp</b>
Operating Weight	15 642 kg	<b>34,484 lb</b>	20 308 kg	<b>44,771 lb</b>
Engine Model	<b>C7.1 ACERT</b>		<b>C7.1 ACERT</b>	
Rated Engine RPM	<b>1800</b>		<b>1800</b>	
Bore	105 mm	<b>4.13"</b>	105 mm	<b>4.13"</b>
Stroke	135 mm	<b>5.31"</b>	135 mm	<b>5.31"</b>
No. Cylinders	<b>6</b>		<b>6</b>	
Displacement	7.01 L	<b>427.8 in<sup>3</sup></b>	7.01 L	<b>427.8 in<sup>3</sup></b>
Speeds Forward/Reverse	km/h	<b>mph</b>	km/h	<b>mph</b>
1st	0-10	<b>0-6.2</b>	0-10	<b>0-6.2</b>
2nd	<b>Infinitely</b>		<b>Infinitely</b>	
3rd	<b>Variable</b>		<b>Variable</b>	
Hydraulic Cycle Time, Bucket Empty, in Seconds:				
Raise	<b>5.4</b>		<b>5.5</b>	
Dump	<b>1.4</b>		<b>1.3</b>	
Lower (Empty, Float Down)	<b>3.0</b>		<b>2.0</b>	
Track Rollers (Each Side)	<b>6</b>		<b>7</b>	
Width of Standard Track Shoe	480 mm	<b>19"</b>	550 mm	<b>21.6"</b>
Length of Track on Ground	2323 mm	<b>91.4"</b>	2543 mm	<b>100.1"</b>
Ground Contact Area (with Standard Shoes)	2.23 m <sup>2</sup>	<b>3565 in<sup>2</sup></b>	2.8 m <sup>2</sup>	<b>4340 in<sup>2</sup></b>
Ground Pressure	68.8 kPa	<b>10.0 psi</b>	71.5 kPa	<b>10.3 psi</b>
Ground Clearance	416 mm	<b>16.3"</b>	471 mm	<b>18.5"</b>
Track Gauge	1836 mm	<b>72.3"</b>	1850 mm	<b>72.8"</b>
Width without Bucket (with Standard Shoes)	2316 mm	<b>91.2"</b>	2400 mm	<b>94.5"</b>
Fuel Tank Refill Capacity	265 L	<b>70 U.S. gal</b>	320 L	<b>84.5 U.S. gal</b>
Diesel Exhaust Fluid Refill Capacity	16 L	<b>4.22 U.S. gal</b>	16 L	<b>4.22 U.S. gal</b>
Hydraulic System Refill Capacity	70 L	<b>18.5 U.S. gal</b>	90 L	<b>23.8 U.S. gal</b>

BUCKET	General Purpose Bare		General Purpose Bolt-on Adapters, Long Teeth & Segments		General Purpose Bolt-on Cutting Edge		General Purpose Flush Weld-on Adapters & Long Teeth	
	m <sup>3</sup>	yd <sup>3</sup>	m <sup>3</sup>	yd <sup>3</sup>	m <sup>3</sup>	yd <sup>3</sup>	m <sup>3</sup>	yd <sup>3</sup>
Capacity, Rated (Nominal Heaped)	1.75 m <sup>3</sup>	<b>2.29 yd<sup>3</sup></b>	1.85 m <sup>3</sup>	<b>2.42 yd<sup>3</sup></b>	1.85 m <sup>3</sup>	<b>2.42 yd<sup>3</sup></b>	1.85 m <sup>3</sup>	<b>2.42 yd<sup>3</sup></b>
Struck	1.45 m <sup>3</sup>	<b>1.90 yd<sup>3</sup></b>	1.55 m <sup>3</sup>	<b>2.03 yd<sup>3</sup></b>	1.55 m <sup>3</sup>	<b>2.03 yd<sup>3</sup></b>	1.45 m <sup>3</sup>	<b>1.90 yd<sup>3</sup></b>
Cutting Edge, Type	<b>Straight</b>		<b>Straight</b>		<b>Straight</b>		—	
Bucket Width ◀	2392 mm	<b>94.2"</b>	2485 mm	<b>97.8"</b>	2395 mm	<b>94.3"</b>	2438 mm	<b>96"</b>
Teeth	<b>None</b>		<b>8, bolt-on plus replaceable tips</b>		<b>None</b>		<b>8, bolt-on plus replaceable tips</b>	
Dump Clearance @ Full Lift and 45° Discharge	2855 mm	<b>112.4"</b>	2616 mm	<b>102.9"</b>	2786 mm	<b>109.6"</b>	2659 mm	<b>104.7"</b>
Reach at 45° Discharge Angle 2133 mm (7'0") Clearance	1550 mm	<b>61"</b>	1630 mm	<b>64.2"</b>	1559 mm	<b>61.4"</b>	1656 mm	<b>65.2"</b>
Reach @ Full Lift and 45° Discharge	928 mm	<b>36.5"</b>	1099 mm	<b>43.3"</b>	961 mm	<b>37.8"</b>	1104 mm	<b>43.5"</b>
Digging Depth	92 mm	<b>3.6"</b>	140 mm	<b>5.5"</b>	117 mm	<b>4.6"</b>	105 mm	<b>4.1"</b>
Ground Clearance from Face of Shoes	416 mm	<b>16.3"</b>	416 mm	<b>16.3"</b>	416 mm	<b>16.3"</b>	416 mm	<b>16.3"</b>
Overall Machine Width without Bucket (with Standard Track) 480 mm (19")	2280 mm	<b>89.7"</b>	2280 mm	<b>89.7"</b>	2280 mm	<b>89.7"</b>	2280 mm	<b>89.7"</b>
Overall Machine Width without Bucket (with Narrow Track) 380 mm (15")	2180 mm	<b>85.8"</b>	2180 mm	<b>85.8"</b>	2180 mm	<b>85.8"</b>	2180 mm	<b>85.8"</b>
Overall Length	5926 mm	<b>233.3"</b>	6252 mm	<b>246.1"</b>	6017 mm	<b>236.9"</b>	6198 mm	<b>244"</b>
Overall Height	3105 mm	<b>122.2"</b>	3105 mm	<b>122.2"</b>	3105 mm	<b>122.2"</b>	3105 mm	<b>122.2"</b>
Static Tipping Load	11 431 kg	<b>25,201 lb</b>	11 089 kg	<b>24,447 lb</b>	11 252 kg	<b>24,806 lb</b>	11 255 kg	<b>24,813 lb</b>
Breakout Force*	160.5 kN	<b>36,092 lb</b>	157.8 kN	<b>35,491 lb</b>	159.3 kN	<b>35,828 lb</b>	162.5 kN	<b>36,549 lb</b>
Operating Weight**	15 517 kg	<b>34,209 lb</b>	15 758 kg	<b>34,740 lb</b>	15 638 kg	<b>34,475 lb</b>	15 635 kg	<b>34,469 lb</b>

\* Breakout force is measured 100 mm (3.94") behind tip of cutting edge with bucket hinge pin as pivot point.

\*\* Operating weight includes coolant, lubricants, full fuel tank, ROPS cab, bucket, and 75 kg (165 lb) operator.

◀ Bolt-on teeth increase bucket width by 52 mm (2"). Bolt-on cutting edge increases bucket width by 17 mm (0.67").

Machine stability can be affected by the addition of other attachments. Add or subtract the following to/from machine operating weight and static tipping load:

	Change in Operating Weight		Change in Static Tipping Load for General Purpose Bucket	
	kg	lb	kg	lb
Ripper (includes ripper, rear lines, and third valves) . . . . .	+461	<b>+1016</b>	+967	<b>+2131</b>
Air conditioner . . . . .	<b>Standard</b>		<b>Standard</b>	
Wide track shoes, 480 mm (19") double grouser . . . . .	-588	<b>-1296</b>	-405	<b>- 892</b>
Rear bumper (removal) . . . . .	-185	<b>- 408</b>	-411	<b>- 906</b>

BUCKET	Multi-Purpose Bare		Multi-Purpose Bolt-on Adapters, Long Tips & Segments		Multi-Purpose Bolt-on Cutting Edge	
Capacity, Rated (Nominal Heaped)	1.5 m <sup>3</sup>	<b>1.96 yd<sup>3</sup></b>	1.6 m <sup>3</sup>	<b>2.09 yd<sup>3</sup></b>	1.6 m <sup>3</sup>	<b>2.09 yd<sup>3</sup></b>
Struck	1.25 m <sup>3</sup>	<b>1.63 yd<sup>3</sup></b>	1.35 m <sup>3</sup>	<b>1.76 yd<sup>3</sup></b>	1.35 m <sup>3</sup>	<b>1.76 yd<sup>3</sup></b>
Cutting Edge, Type	<b>Straight</b>		<b>Straight</b>		<b>Straight</b>	
Bucket Width◀	2378 mm	<b>93.6"</b>	2471 mm	<b>97.3"</b>	2395 mm	<b>94.3"</b>
Teeth	<b>None</b>		<b>8, bolt-on plus replaceable tips</b>		<b>None</b>	
Dump Clearance @ Full Lift and 45° Discharge	2738 mm	<b>107.7"</b>	2499 mm	<b>98.3"</b>	2669 mm	<b>105"</b>
Reach at 45° Discharge Angle 2133 mm (7'0") Clearance	1434 mm	<b>56.5"</b>	1457 mm	<b>57.4"</b>	1428 mm	<b>56.2"</b>
Reach @ Full Lift and 45° Discharge	973 mm	<b>38.3"</b>	1144 mm	<b>45"</b>	1006 mm	<b>39.6"</b>
Digging Depth	142 mm	<b>5.6"</b>	190 mm	<b>7.5"</b>	147 mm	<b>5.8"</b>
Overall Length	6077 mm	<b>239.3"</b>	6401 mm	<b>252"</b>	6167 mm	<b>242.8"</b>
Overall Height	3105 mm	<b>122.2"</b>	3105 mm	<b>122.2"</b>	3105 mm	<b>122.2"</b>
Static Tipping Load	10 831 kg	<b>23,878 lb</b>	10 492 kg	<b>23,130 lb</b>	10 663 kg	<b>23,507 lb</b>
Breakout Force*	137.2 kN	<b>30,843 lb</b>	134.3 kN	<b>30,191 lb</b>	135.5 kN	<b>30,461 lb</b>
Operating Weight**	16 062 kg	<b>35,410 lb</b>	16 302 kg	<b>35,939 lb</b>	16 183 kg	<b>35,677 lb</b>

\* Breakout force is measured 100 mm (3.94") behind tip of cutting edge with bucket hinge pin as pivot point.

\*\* Operating weight includes coolant, lubricants, full fuel tank, ROPS cab, General Purpose bucket, and 80 kg (176 lb) operator.

◀ Bolt-on teeth increase bucket width by 52 mm (2"). Bolt-on cutting edge increases bucket width by 17 mm (0.67").

Machine stability can be affected by the addition of other attachments.

BUCKET	General Purpose Bare		General Purpose Bolt-on Cutting Edge		General Purpose Flush Weld-on Adapters & Long Tips		General Purpose Bolt-on Adapters, Long Tips & Segments	
	Capacity, Rated (Nominal Heaped)	2.3 m <sup>3</sup>	3.0 yd <sup>3</sup>	2.45 m <sup>3</sup>	3.2 yd <sup>3</sup>	2.45 m <sup>3</sup>	3.2 yd <sup>3</sup>	2.45 m <sup>3</sup>
Struck	2.0 m <sup>3</sup>	2.6 yd <sup>3</sup>	2.14 m <sup>3</sup>	2.8 yd <sup>3</sup>	2.0 m <sup>3</sup>	2.6 yd <sup>3</sup>	2.14 m <sup>3</sup>	2.8 yd <sup>3</sup>
Cutting Edge, Type	Straight		Straight		—		Straight	
Bucket Width*	2508 mm	98.7"	2539 mm	99.9"	2583 mm	101.6"	2612 mm	102.8"
Teeth	None		None		8, weld-on plus replaceable tips		8, weld-on plus replaceable tips	
Dump Clearance @ Full Lift and 45° Discharge	3155 mm	124.2"	3068 mm	120.7"	2951 mm	116.1"	2915 mm	114.7"
Reach at 45° Discharge Angle 2133 mm (7'0") Clearance	1771 mm	69.7"	1793 mm	70.5"	1926 mm	75.8"	1886 mm	74.2"
Reach @ Full Lift and 45° Discharge	1060 mm	41.7"	1215 mm	47.8"	1397 mm	55"	1373 mm	54"
Digging Depth	80 mm	3.1"	115 mm	4.5"	95 mm	3.7"	138 mm	5.4"
Ground Clearance from Face of Shoes	471 mm	18.5"	471 mm	18.5"	471 mm	18.5"	471 mm	18.5"
Overall Machine Width without Bucket (with Standard Track) 550 mm (21.6")	2400 mm	94.5"	2400 mm	94.5"	2400 mm	94.5"	2400 mm	94.5"
Overall Machine Width without Bucket (with Narrow Track) 450 mm (18")	2300 mm	90.5"	2300 mm	90.5"	2300 mm	90.5"	2300 mm	90.5"
Overall Length	6584 mm	259.2"	6676 mm	262.8"	6883 mm	270.9"	6896 mm	271.4"
Overall Height	3335 mm	131.3"	3335 mm	131.3"	3335 mm	131.3"	3335 mm	131.3"
Static Tipping Load	14 969 kg	33,000 lb	14 685 kg	32,375 lb	14 815 kg	32,661 lb	14 482 kg	31,927 lb
Breakout Force**	208.6 kN	46,895 lb	206.1 kN	46,333 lb	207.4 kN	46,625 lb	203.8 kN	45,816 lb
Operating Weight***	20 220 kg	44,585 lb	20 433 kg	45,055 lb	20 332 kg	44,832 lb	20 592 kg	45,405 lb

\*With bolt-on cutting edge add 17 mm (0.67"), with bolt-on teeth add 52 mm (2"), for flush weld-on teeth add 75 mm (3").

\*\*Breakout force is measured 100 mm (3.94") behind tip of cutting edge with bucket hinge pin as pivot point.

\*\*\*Operating weight includes coolant, lubricants, full fuel tank, ROPS cab, bucket, and 75 kg (165 lb) operator.

Machine stability can be affected by the addition of other attachments. Add or subtract the following to/from machine operating weight and static tipping load:

	Change in Operating Weight		Change in Static Tipping Load for General Purpose Bucket	
	kg	lb	kg	lb
Ripper (includes ripper, rear lines, and third valves) . . . . .	+639	+1409	+1421	+3133
Rear bumper (removal) . . . . .	-195	- 430	- 464	-1023

BUCKET	Multi-Purpose Bare		Multi-Purpose Bolt-on Segments & Long Teeth		Multi-Purpose Bolt-on Cutting Edge	
Capacity, Rated (Nominal Heaped)	1.9 m <sup>3</sup>	2.5 yd <sup>3</sup>	2.0 m <sup>3</sup>	2.6 yd <sup>3</sup>	2.0 m <sup>3</sup>	2.6 yd <sup>3</sup>
Struck	1.6 m <sup>3</sup>	2.1 yd <sup>3</sup>	1.7 m <sup>3</sup>	2.2 yd <sup>3</sup>	1.7 m <sup>3</sup>	2.2 yd <sup>3</sup>
Cutting Edge, Type	Straight		Straight		Straight	
Bucket Width*	2482 mm	97.7"	2575 mm	101.3"	2515 mm	99"
Teeth	None		8, bolt-on plus replaceable tips		None	
Dump Clearance @ Full Lift and 45° Discharge	3000 mm	118.1"	2772 mm	109.1"	2909 mm	114.5"
Reach at 45° Discharge Angle 2133 mm (7'0") Clearance	1598 mm	62.9"	1650 mm	65.0"	1607 mm	63.3"
Reach @ Full Lift and 45° Discharge	1065 mm	41.9"	1240 mm	48.8"	1119 mm	44"
Digging Depth	161 mm	6.3"	209 mm	8.2"	191 mm	7.5"
Ground Clearance from Face of Shoes	471 mm	18.5"	471 mm	18.5"	471 mm	18.5"
Overall Machine Width without Bucket (with Standard Track) 550 mm (21.6")	2400 mm	94.5"	2400 mm	94.5"	2400 mm	94.5"
Overall Machine Width without Bucket (with Narrow Track) 450 mm (18")	2300 mm	90.5"	2300 mm	90.5"	2300 mm	90.5"
Overall Length	6698 mm	263.7"	7013 mm	276.1"	6820 mm	268.5"
Overall Height	3335 mm	131.3"	3335 mm	131.3"	3335 mm	131.3"
Static Tipping Load	14 487 kg	31,944 lb	14 124 kg	31,143 lb	14 208 kg	31,329 lb
Breakout Force**	193.2 kN	43,333 lb	189.2 kN	42,533 lb	193.7 kN	43,545 lb
Operating Weight***	20 710 kg	45,666 lb	20 975 kg	46,250 lb	20 911 kg	46,109 lb

\*With bolt-on cutting edge add 17 mm (0.67"), for bolt-on teeth add 52 mm (2").

\*\*Breakout force is measured 100 mm (3.94") behind tip of cutting edge with bucket hinge pin as pivot point.

\*\*\*Operating weight includes coolant, lubricants, full fuel tank, ROPS cab, bucket, and 75 kg (165 lb) operator.

Machine stability can be affected by the addition of other attachments.

BUCKET	General Purpose Bare		General Purpose Bolt-on Adapters, Long Tips & Segments		General Purpose Bolt-on Cutting Edge		General Purpose Flush Weld-on Adapters & Long Tips	
Capacity, Rated (Nominal Heaped)	2.86 m <sup>3</sup>	<b>3.74 yd<sup>3</sup></b>	3.21 m <sup>3</sup>	<b>4.20 yd<sup>3</sup></b>	3.04 m <sup>3</sup>	<b>3.98 yd<sup>3</sup></b>	3.21 m <sup>3</sup>	<b>4.20 yd<sup>3</sup></b>
Struck	2.44 m <sup>3</sup>	<b>3.19 yd<sup>3</sup></b>	2.81 m <sup>3</sup>	<b>3.68 yd<sup>3</sup></b>	2.66 m <sup>3</sup>	<b>3.48 yd<sup>3</sup></b>	2.81 m <sup>3</sup>	<b>3.68 yd<sup>3</sup></b>
Cutting Edge, Type	Straight		Straight		Straight		Spade	
Bucket Width◀	2910 mm	<b>114.6"</b>	2910 mm	<b>114.6"</b>	2910 mm	<b>114.6"</b>	2990 mm	<b>117.7"</b>
Teeth	None		8, bolt-on plus replaceable tips		None		8, weld-on plus replaceable tips	
Dump Clearance @ Full Lift and 45° Discharge	3375 mm	<b>132.9"</b>	3013 mm	<b>118.6"</b>	3193 mm	<b>125.7"</b>	3069 mm	<b>120.8"</b>
Reach @ 45° Discharge Angle 2133 mm (7'0") Clearance	1839 mm	<b>72.4"</b>	2065 mm	<b>81.3"</b>	1929 mm	<b>75.9"</b>	2110 mm	<b>83.1"</b>
Reach @ Full Lift and 45° Discharge	1165 mm	<b>45.9"</b>	1327 mm	<b>52.2"</b>	1199 mm	<b>47.2"</b>	1357 mm	<b>53.4"</b>
Digging Depth	97 mm	<b>3.8"</b>	159 mm	<b>6.3"</b>	127 mm	<b>5.0"</b>	129 mm	<b>5.1"</b>
Ground Clearance from Face of Shoes	483 mm	<b>19.0"</b>	483 mm	<b>19.0"</b>	483 mm	<b>19.0"</b>	483 mm	<b>19.0"</b>
Overall Machine Width without Bucket (with Standard Track)	2710 mm	<b>106.7"</b>	2710 mm	<b>106.7"</b>	2710 mm	<b>106.7"</b>	2710 mm	<b>106.7"</b>
Overall Machine Width without Bucket (with Optional Track)	2835 mm	<b>111.6"</b>	2835 mm	<b>111.6"</b>	2835 mm	<b>111.6"</b>	2835 mm	<b>111.6"</b>
Overall Length	7194 mm	<b>283.2"</b>	7305 mm	<b>287.6"</b>	7275 mm	<b>286.4"</b>	7479 mm	<b>294.4"</b>
Overall Height	3510 mm	<b>138.2"</b>	3510 mm	<b>138.2"</b>	3510 mm	<b>138.2"</b>	3510 mm	<b>138.2"</b>
Static Tipping Load***	21 179 kg	<b>46,700 lb</b>	20 831 kg	<b>45,932 lb</b>	20 959 kg	<b>46,215 lb</b>	21 006 kg	<b>46,318 lb</b>
Breakout Force*	281 kN	<b>63,225 lb</b>	220 kN	<b>49,500 lb</b>	261 kN	<b>58,725 lb</b>	—	—
Operating Weight**	27 371 kg	<b>60,353 lb</b>	27 744 kg	<b>61,176 lb</b>	27 648 kg	<b>60,964 lb</b>	27 478 kg	<b>60,589 lb</b>

\*Breakout force is measured 100 mm (3.94") behind tip of cutting edge with bucket hinge pin as pivot point.  
 \*\*Operating weight includes lubricants, full fuel tank, ROPS cab, General Purpose bucket, and 80 kg (176 lb) operator.  
 \*\*\*Safe operating bucket load as defined by SAE for Track Loaders should not exceed 35% of static tipping load.  
 ◀Bolt-on teeth increase bucket width by 63.8 mm (2.5"). Bolt-on cutting edge increases bucket width by 19 mm (0.74").

Machine stability can be affected by the addition of other attachments. Add or subtract the following to/from machine operating weight and static tipping load:

	Change in Operating Weight		Change in Static Tipping Load	
	kg	lb	kg	lb
Ripper (includes 3 shanks and rear hydraulic arrangement) . . . . .	—	—	—	—
Rear bumper (removal) . . . . .	—	—	—	—

BUCKET	Multi-Purpose Bare		Multi-Purpose Bolt-on Segments & Long Teeth		Multi-Purpose Bolt-on Cutting Edge	
Capacity, Rated (Nominal Heaped)	2.75 m <sup>3</sup>	<b>3.60 yd<sup>3</sup></b>	3.05 m <sup>3</sup>	<b>3.99 yd<sup>3</sup></b>	2.86 m <sup>3</sup>	<b>3.74 yd<sup>3</sup></b>
Struck	2.33 m <sup>3</sup>	<b>3.05 yd<sup>3</sup></b>	2.7 m <sup>3</sup>	<b>3.53 yd<sup>3</sup></b>	2.44 m <sup>3</sup>	<b>3.19 yd<sup>3</sup></b>
Cutting Edge, Type	<b>Straight</b>		<b>Straight</b>		<b>Straight</b>	
Bucket Width ◀	2972 mm	<b>117.0"</b>	2972 mm	<b>117.0"</b>	2972 mm	<b>117.0"</b>
Teeth	<b>None</b>		<b>8, bolt-on plus replaceable tips</b>		<b>None</b>	
Dump Clearance @ Full Lift and 45° Discharge	3300 mm	<b>129.9"</b>	3106 mm	<b>122.3"</b>	3229 mm	<b>127.1"</b>
Reach @ 45° Discharge Angle 2133 mm (7'0") Clearance	2110 mm	<b>83.1"</b>	2327 mm	<b>91.6"</b>	2160 mm	<b>85.0"</b>
Digging Depth	188 mm	<b>7.4"</b>	244 mm	<b>9.6"</b>	219 mm	<b>8.6"</b>
Ground Clearance from Face of Shoes	582 mm	<b>22.9"</b>	582 mm	<b>22.9"</b>	582 mm	<b>22.9"</b>
Overall Machine Width without Bucket (with Standard Track)	2710 mm	<b>106.7"</b>	2710 mm	<b>106.7"</b>	2710 mm	<b>106.7"</b>
Overall Machine Width without Bucket (with Optional Track)	2835 mm	<b>111.6"</b>	2835 mm	<b>111.6"</b>	2835 mm	<b>111.6"</b>
Overall Length	7445 mm	<b>293.1"</b>	7743 mm	<b>304.8"</b>	7527 mm	<b>296.3"</b>
Overall Height	3510 mm	<b>138.2"</b>	3510 mm	<b>138.2"</b>	3510 mm	<b>138.2"</b>
Static Tipping Load	19 810 kg	<b>43,681 lb</b>	19 455 kg	<b>42,898 lb</b>	19 535 kg	<b>43,075 lb</b>
Breakout Force*	236 kN	<b>53,100 lb</b>	193 kN	<b>43,425 lb</b>	222 kN	<b>49,950 lb</b>
Operating Weight**	28 866 kg	<b>63,650 lb</b>	29 225 kg	<b>64,441 lb</b>	29 143 kg	<b>64,260 lb</b>

\* Breakout force is measured 100 mm (3.94") behind tip of cutting edge with bucket hinge pin as pivot point.

\*\* Operating weight includes lubricants, full fuel tank, ROPS cab, General Purpose bucket, and 80 kg (176 lb) operator.

◀ Bolt-on teeth increase bucket width by 63.8 mm (2.5"). Bolt-on cutting edge increases bucket width by 19 mm (0.74").

Machine stability can be affected by the addition of other attachments.



BUCKET	General Purpose Bare		General Purpose Bolt-on Adapters, Long Teeth & Segments		General Purpose Bolt-on Cutting Edge	
Capacity, Rated (Nominal Heaped)	1.75 m <sup>3</sup>	<b>2.29 yd<sup>3</sup></b>	1.85 m <sup>3</sup>	<b>2.42 yd<sup>3</sup></b>	1.85 m <sup>3</sup>	<b>2.42 yd<sup>3</sup></b>
Struck	1.45 m <sup>3</sup>	<b>1.90 yd<sup>3</sup></b>	1.55 m <sup>3</sup>	<b>2.03 yd<sup>3</sup></b>	1.55 m <sup>3</sup>	<b>2.03 yd<sup>3</sup></b>
Cutting Edge, Type	<b>Straight</b>		<b>Straight</b>		<b>Straight</b>	
Bucket Width ◀	2392 mm	<b>94.2"</b>	2485 mm	<b>97.8"</b>	2395 mm	<b>94.3"</b>
Teeth	<b>None</b>		<b>8, bolt-on plus replaceable tips</b>		<b>None</b>	
Dump Clearance @ Full Lift and 45° Discharge	2855 mm	<b>112.4"</b>	2616 mm	<b>102.9"</b>	2786 mm	<b>109.6"</b>
Reach at 45° Discharge Angle 2133 mm (7'0") Clearance	1550 mm	<b>61"</b>	1630 mm	<b>64.2"</b>	1559 mm	<b>61.4"</b>
Reach @ Full Lift and 45° Discharge	928 mm	<b>36.5"</b>	1099 mm	<b>43.3"</b>	961 mm	<b>37.8"</b>
Digging Depth	92 mm	<b>3.6"</b>	140 mm	<b>5.5"</b>	117 mm	<b>4.6"</b>
Ground Clearance from Face of Shoes	416 mm	<b>16.3"</b>	416 mm	<b>16.3"</b>	416 mm	<b>16.3"</b>
Overall Machine Width without Bucket (with Standard Track) 480 mm (19")	2280 mm	<b>89.7"</b>	2280 mm	<b>89.7"</b>	2280 mm	<b>89.7"</b>
Overall Machine Width without Bucket (with Narrow Track) 380 mm (15")	2180 mm	<b>85.8"</b>	2180 mm	<b>85.8"</b>	2180 mm	<b>85.8"</b>
Overall Length	6131 mm	<b>241.4"</b>	6396 mm	<b>251.8"</b>	6205 mm	<b>244.3"</b>
Overall Height	3155 mm	<b>124.2"</b>	3155 mm	<b>124.2"</b>	3155 mm	<b>124.2"</b>
Static Tipping Load	11 431 kg	<b>25,201 lb</b>	11 089 kg	<b>24,447 lb</b>	11 252 kg	<b>24,806 lb</b>
Breakout Force*	160.5 kN	<b>36,092 lb</b>	157.8 kN	<b>35,491 lb</b>	159.3 kN	<b>35,828 lb</b>
Operating Weight**	15 642 kg	<b>34,484 lb</b>	15 890 kg	<b>35,031 lb</b>	15 790 kg	<b>34,811 lb</b>

\* Breakout force is measured 100 mm (3.94") behind tip of cutting edge with bucket hinge pin as pivot point.

\*\* Operating weight includes coolant, lubricants, full fuel tank, ROPS cab, bucket, and 75 kg (165 lb) operator.

◀ Bolt-on teeth increase bucket width by 52 mm (2"). Bolt-on cutting edge increases bucket width by 17 mm (0.67").

Machine stability can be affected by the addition of other attachments. Add or subtract the following to/from machine operating weight and static tipping load:

	Change in Operating Weight		Change in Static Tipping Load for General Purpose Bucket	
	kg	lb	kg	lb
Ripper (includes ripper, rear lines, and third valves) . . . . .	+704	<b>+1552</b>	+1476	<b>+3254</b>
Air conditioner . . . . .	<b>Standard</b>		<b>Standard</b>	
Wide track shoes, 480 mm (19") double grouser . . . . .	-588	<b>-1296</b>	- 405	<b>- 892</b>
Rear bumper (removal) . . . . .	-167	<b>- 368</b>	- 371	<b>- 818</b>

BUCKET	General Purpose Flush Weld-on Adapters & Long Teeth		Performance Series Bolt-on Adapters, Long Teeth & Segments	
Capacity, Rated (Nominal Heaped)	1.85 m <sup>3</sup>	2.42 yd <sup>3</sup>	2.1 m <sup>3</sup>	2.75 yd <sup>3</sup>
Struck	1.45 m <sup>3</sup>	1.90 yd <sup>3</sup>	1.8 m <sup>3</sup>	2.35 yd <sup>3</sup>
Cutting Edge, Type	—		Straight	
Bucket Width◀	2438 mm	96"	2536 mm	99.8"
Teeth	8, bolt-on plus replaceable tips		8, bolt-on plus replaceable tips	
Dump Clearance @ Full Lift and 45° Discharge	2659 mm	104.7"	2552 mm	100.5"
Reach at 45° Discharge Angle 2133 mm (7'0") Clearance	1656 mm	65.2"	1694 mm	66.7"
Reach @ Full Lift and 45° Discharge	1104 mm	43.5"	1163 mm	45.8"
Digging Depth	105 mm	4.1"	140 mm	5.5"
Ground Clearance from Face of Shoes	416 mm	16.3"	416 mm	16.3"
Overall Machine Width without Bucket (with Standard Track) 480 mm (19")	2280 mm	89.7"	2316 mm	91.2"
Overall Machine Width without Bucket (with Narrow Track) 380 mm (15")	2180 mm	85.8"	2216 mm	87.2"
Overall Length	6394 mm	251.7"	6476 mm	255.2"
Overall Height	3155 mm	124.2"	3155 mm	124.2"
Static Tipping Load	11 255 kg	24,813 lb	10 786 kg	23,779 lb
Breakout Force*	162.5 kN	36,549 lb	143.5 kN	32,260 lb
Operating Weight**	15 787 kg	34,804 lb	16 193 kg	35,698 lb

\* Breakout force is measured 100 mm (3.94") behind tip of cutting edge with bucket hinge pin as pivot point.

\*\* Operating weight includes coolant, lubricants, full fuel tank, ROPS cab, bucket, and 75 kg (165 lb) operator.

◀ Bolt-on teeth increase bucket width by 52 mm (2"). Bolt-on cutting edge increases bucket width by 17 mm (0.67").

Machine stability can be affected by the addition of other attachments. Add or subtract the following to/from machine operating weight and static tipping load:

	Change in Operating Weight		Change in Static Tipping Load for General Purpose Bucket	
	kg	lb	kg	lb
Ripper (includes ripper, rear lines, and third valves) . . . . .	+704	+1552	+1476	+3254
Air conditioner . . . . .	Standard		Standard	
Wide track shoes, 480 mm (19") double grouser . . . . .	-588	-1296	- 405	- 892
Rear bumper (removal) . . . . .	-167	- 368	- 371	- 818

BUCKET	Multi-Purpose Bare		Multi-Purpose Bolt-on Adapters, Long Tips & Segments		Multi-Purpose Bolt-on Cutting Edge	
Capacity, Rated (Nominal Heaped)	1.5 m <sup>3</sup>	<b>1.96 yd<sup>3</sup></b>	1.6 m <sup>3</sup>	<b>2.09 yd<sup>3</sup></b>	1.6 m <sup>3</sup>	<b>2.09 yd<sup>3</sup></b>
Struck	1.25 m <sup>3</sup>	<b>1.63 yd<sup>3</sup></b>	1.35 m <sup>3</sup>	<b>1.76 yd<sup>3</sup></b>	1.35 m <sup>3</sup>	<b>1.76 yd<sup>3</sup></b>
Cutting Edge, Type	<b>Straight</b>		<b>Straight</b>		<b>Straight</b>	
Bucket Width ◀	2378 mm	<b>93.6"</b>	2471 mm	<b>97.3"</b>	2395 mm	<b>94.3"</b>
Teeth	<b>None</b>		<b>8, bolt-on plus replaceable tips</b>		<b>None</b>	
Dump Clearance @ Full Lift and 45° Discharge	2738 mm	<b>107.7"</b>	2499 mm	<b>98.3"</b>	2669 mm	<b>105"</b>
Reach at 45° Discharge Angle 2133 mm (7'0") Clearance	1434 mm	<b>56.5"</b>	1457 mm	<b>57.4"</b>	1428 mm	<b>56.2"</b>
Reach @ Full Lift and 45° Discharge	973 mm	<b>38.3"</b>	1144 mm	<b>45"</b>	1006 mm	<b>39.6"</b>
Digging Depth	142 mm	<b>5.6"</b>	190 mm	<b>7.5"</b>	147 mm	<b>5.8"</b>
Overall Length	6244 mm	<b>245.8"</b>	6568 mm	<b>258.6"</b>	6334 mm	<b>245.5"</b>
Overall Height	3155 mm	<b>124.2"</b>	3155 mm	<b>124.2"</b>	3155 mm	<b>124.2"</b>
Static Tipping Load	10 831 kg	<b>23,878 lb</b>	10 492 kg	<b>23,130 lb</b>	10 663 kg	<b>23,507 lb</b>
Breakout Force*	137.2 kN	<b>30,843 lb</b>	134.3 kN	<b>30,191 lb</b>	135.5 kN	<b>30,461 lb</b>
Operating Weight**	16 187 kg	<b>35,686 lb</b>	16 427 kg	<b>36,215 lb</b>	16 308 kg	<b>35,953 lb</b>

\* Breakout force is measured 100 mm (3.94") behind tip of cutting edge with bucket hinge pin as pivot point.

\*\* Operating weight includes coolant, lubricants, full fuel tank, ROPS cab, General Purpose bucket, and 80 kg (176 lb) operator.

◀ Bolt-on teeth increase bucket width by 52 mm (2"). Bolt-on cutting edge increases bucket width by 17 mm (0.67").

Machine stability can be affected by the addition of other attachments.

BUCKET	General Purpose Bare		General Purpose Bolt-on Cutting Edge		General Purpose Flush Weld-on Adapters & Long Tips	
Capacity, Rated (Nominal Heaped)	2.3 m <sup>3</sup>	<b>3.0 yd<sup>3</sup></b>	2.45 m <sup>3</sup>	<b>3.2 yd<sup>3</sup></b>	2.45 m <sup>3</sup>	<b>3.2 yd<sup>3</sup></b>
Struck	2.0 m <sup>3</sup>	<b>2.6 yd<sup>3</sup></b>	2.14 m <sup>3</sup>	<b>2.8 yd<sup>3</sup></b>	2.0 m <sup>3</sup>	<b>2.6 yd<sup>3</sup></b>
Cutting Edge, Type	<b>Straight</b>		<b>Straight</b>		—	
Bucket Width*	2508 mm	<b>98.7"</b>	2539 mm	<b>99.9"</b>	2583 mm	<b>101.6"</b>
Teeth	<b>None</b>		<b>None</b>		<b>8, weld-on plus replaceable tips</b>	
Dump Clearance @ Full Lift and 45° Discharge	3155 mm	<b>124.2"</b>	3068 mm	<b>120.7"</b>	2951 mm	<b>116.1"</b>
Reach at 45° Discharge Angle 2133 mm (7'0") Clearance	1771 mm	<b>69.7"</b>	1793 mm	<b>70.5"</b>	1926 mm	<b>75.8"</b>
Reach @ Full Lift and 45° Discharge	1060 mm	<b>41.7"</b>	1215 mm	<b>47.8"</b>	1397 mm	<b>55"</b>
Digging Depth	80 mm	<b>3.1"</b>	115 mm	<b>4.5"</b>	95 mm	<b>3.7"</b>
Ground Clearance from Face of Shoes	471 mm	<b>18.5"</b>	471 mm	<b>18.5"</b>	471 mm	<b>18.5"</b>
Overall Machine Width without Bucket (with Standard Track) 550 mm (21.6")	2400 mm	<b>94.5"</b>	2400 mm	<b>94.5"</b>	2400 mm	<b>94.5"</b>
Overall Machine Width without Bucket (with Narrow Track) 450 mm (18")	2300 mm	<b>90.5"</b>	2300 mm	<b>90.5"</b>	2300 mm	<b>90.5"</b>
Overall Length	6644 mm	<b>261.6"</b>	6766 mm	<b>266.4"</b>	6967 mm	<b>274.3"</b>
Overall Height	3325 mm	<b>130.9"</b>	3325 mm	<b>130.9"</b>	3325 mm	<b>130.9"</b>
Static Tipping Load	14 969 kg	<b>33,000 lb</b>	14 685 kg	<b>32,375 lb</b>	14 815 kg	<b>32,661 lb</b>
Breakout Force**	208.6 kN	<b>46,895 lb</b>	206.1 kN	<b>46,333 lb</b>	207.4 kN	<b>46,625 lb</b>
Operating Weight***	20 308 kg	<b>44,771 lb</b>	20 509 kg	<b>45,215 lb</b>	20 408 kg	<b>44,992 lb</b>

\*With bolt-on cutting edge add 17 mm (0.67"), with bolt-on teeth add 52 mm (2"), for flush weld-on teeth add 75 mm (3").

\*\*Breakout force is measured 100 mm (3.94") behind tip of cutting edge with bucket hinge pin as pivot point.

\*\*\*Operating weight includes coolant, lubricants, full fuel tank, ROPS cab, bucket, and 75 kg (165 lb) operator.

Machine stability can be affected by the addition of other attachments. Add or subtract the following to/from machine operating weight and static tipping load:

	Change in Operating Weight		Change in Static Tipping Load for General Purpose Bucket	
	kg	lb	kg	lb
Ripper (includes ripper, rear lines, and third valves) . . . . .	+639	<b>+1409</b>	+1421	<b>+3133</b>
Rear bumper (removal) . . . . .	-195	<b>- 430</b>	- 464	<b>-1023</b>

BUCKET	General Purpose Bolt-on Adapters, Long Tips & Segments		Performance Series Bolt-on Adapters, Long Teeth & Segments	
Capacity, Rated (Nominal Heaped)	2.45 m <sup>3</sup>	<b>3.2 yd<sup>3</sup></b>	2.8 m <sup>3</sup>	<b>3.7 yd<sup>3</sup></b>
Struck	2.14 m <sup>3</sup>	<b>2.8 yd<sup>3</sup></b>	2.5 m <sup>3</sup>	<b>3.3 yd<sup>3</sup></b>
Cutting Edge, Type	<b>Straight</b>		<b>Straight</b>	
Bucket Width*	2612 mm	<b>102.8"</b>	2712 mm	<b>106.8"</b>
Teeth	<b>8, weld-on plus replaceable tips</b>		<b>8, bolt-on plus replaceable tips</b>	
Dump Clearance @ Full Lift and 45° Discharge	2915 mm	<b>114.7"</b>	2840 mm	<b>111.8"</b>
Reach at 45° Discharge Angle 2133 mm (7'0") Clearance	1886 mm	<b>74.2"</b>	1824 mm	<b>71.8"</b>
Reach @ Full Lift and 45° Discharge	1373 mm	<b>54"</b>	1298 mm	<b>51.1"</b>
Digging Depth	138 mm	<b>5.4"</b>	138 mm	<b>5.4"</b>
Ground Clearance from Face of Shoes	471 mm	<b>18.5"</b>	471 mm	<b>18.5"</b>
Overall Machine Width without Bucket (with Standard Track) 550 mm (21.6")	2400 mm	<b>94.5"</b>	2400 mm	<b>94.5"</b>
Overall Machine Width without Bucket (with Narrow Track) 450 mm (18")	2300 mm	<b>90.5"</b>	2300 mm	<b>90.5"</b>
Overall Length	7001 mm	<b>275.6"</b>	7107 mm	<b>279.8"</b>
Overall Height	3325 mm	<b>130.9"</b>	3325 mm	<b>130.9"</b>
Static Tipping Load	14 482 kg	<b>31,927 lb</b>	14 377 kg	<b>31,696 lb</b>
Breakout Force**	203.8 kN	<b>45,816 lb</b>	185.3 kN	<b>41,651 lb</b>
Operating Weight***	20 668 kg	<b>45,565 lb</b>	20 753 kg	<b>45,753 lb</b>

\*With bolt-on cutting edge add 17 mm (0.67"), with bolt-on teeth add 52 mm (2"), for flush weld-on teeth add 75 mm (3").

\*\*Breakout force is measured 100 mm (3.94") behind tip of cutting edge with bucket hinge pin as pivot point.

\*\*\*Operating weight includes coolant, lubricants, full fuel tank, ROPS cab, bucket, and 75 kg (165 lb) operator.

Machine stability can be affected by the addition of other attachments. Add or subtract the following to/from machine operating weight and static tipping load:

	Change in Operating Weight		Change in Static Tipping Load for General Purpose Bucket	
	kg	lb	kg	lb
Ripper (includes ripper, rear lines, and third valves) . . . . .	+639	<b>+1409</b>	+1421	<b>+3133</b>
Rear bumper (removal) . . . . .	-195	<b>- 430</b>	- 464	<b>-1023</b>

BUCKET	Multi-Purpose Bare		Multi-Purpose Bolt-on Segments & Long Teeth		Multi-Purpose Bolt-on Cutting Edge	
Capacity, Rated (Nominal Heaped)	1.9 m <sup>3</sup>	2.5 yd <sup>3</sup>	2.0 m <sup>3</sup>	2.6 yd <sup>3</sup>	2.0 m <sup>3</sup>	2.6 yd <sup>3</sup>
Struck	1.6 m <sup>3</sup>	2.1 yd <sup>3</sup>	1.7 m <sup>3</sup>	2.2 yd <sup>3</sup>	1.7 m <sup>3</sup>	2.2 yd <sup>3</sup>
Cutting Edge, Type	Straight		Straight		Straight	
Bucket Width*	2482 mm	97.7"	2575 mm	101.3"	2515 mm	99"
Teeth	None		8, bolt-on plus replaceable tips		None	
Dump Clearance @ Full Lift and 45° Discharge	3000 mm	118.1"	2772 mm	109.1"	2909 mm	114.5"
Reach at 45° Discharge Angle 2133 mm (7'0") Clearance	1598 mm	62.9"	1650 mm	65.0"	1607 mm	63.3"
Reach @ Full Lift and 45° Discharge	1065 mm	41.9"	1240 mm	48.8"	1119 mm	44"
Digging Depth	161 mm	6.3"	209 mm	8.2"	191 mm	7.5"
Ground Clearance from Face of Shoes	471 mm	18.5"	471 mm	18.5"	471 mm	18.5"
Overall Machine Width without Bucket (with Standard Track) 550 mm (21.6")	2400 mm	94.5"	2400 mm	94.5"	2400 mm	94.5"
Overall Machine Width without Bucket (with Narrow Track) 450 mm (18")	2300 mm	90.5"	2300 mm	90.5"	2300 mm	90.5"
Overall Length	6758 mm	266.1"	7073 mm	278.5"	6880 mm	270.9"
Overall Height	3325 mm	130.9"	3325 mm	130.9"	3325 mm	130.9"
Static Tipping Load	14 487 kg	31,944 lb	14 124 kg	31,143 lb	14 208 kg	31,329 lb
Breakout Force**	193.2 kN	43,333 lb	189.2 kN	42,533 lb	193.7 kN	43,545 lb
Operating Weight***	20 786 kg	45,825 lb	21 051 kg	46,410 lb	20 987 kg	46,268 lb

\*With bolt-on cutting edge add 17 mm (0.67"), for bolt-on teeth add 52 mm (2").

\*\*Breakout force is measured 100 mm (3.94") behind tip of cutting edge with bucket hinge pin as pivot point.

\*\*\*Operating weight includes coolant, lubricants, full fuel tank, ROPS cab, bucket, and 75 kg (165 lb) operator.

Machine stability can be affected by the addition of other attachments.

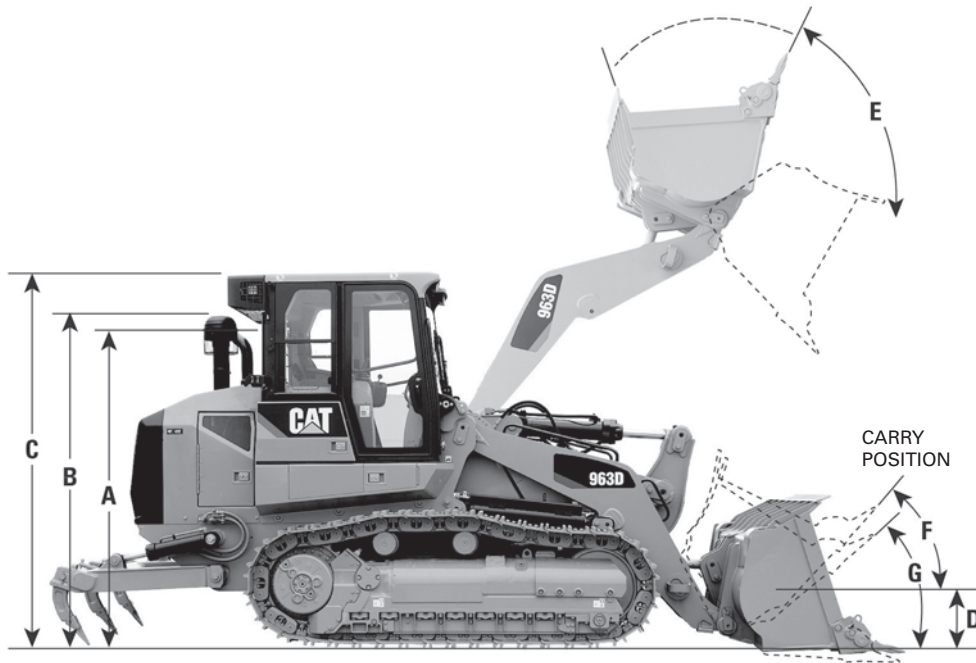

	953D		963D		973D	
A Height to Top of Seat	2560 mm	<b>100.7"</b>	2790 mm	<b>109.8"</b>	2975 mm	<b>117.1"</b>
B Height to Top of Stack	2783.5 mm	<b>109.6"</b>	2953 mm	<b>116"</b>	3018 mm	<b>118.8"</b>
C Height to Top of ROPS	3105 mm	<b>122.2"</b>	3335 mm	<b>131"</b>	3510 mm	<b>138.2"</b>
D Hinge Pin Height at Carry Position	421 mm	<b>16.5"</b>	467 mm	<b>18"</b>	483 mm	<b>19.0"</b>
E Rollback at Maximum Lift		<b>56°</b>		<b>52°</b>		<b>59°</b>
F Rollback at Carry Height		<b>48°</b>		<b>50°</b>		<b>49°</b>
G Rollback at Ground Level		<b>41°</b>		<b>43°</b>		<b>42°</b>
Grading Angle (Bare Edge)		<b>74°</b>		<b>63°</b>		<b>85°</b>
Width without Bucket (standard track)	2280 mm	<b>89.7"</b>	2400 mm	<b>94"</b>	2710 mm	<b>106.7"</b>
(optional track)	2180 mm	<b>85.8"</b>	2300 mm	<b>90.5"</b>	2835 mm	<b>111.6"</b>
Weight of General Purpose Bucket with Teeth & Segments	1266 kg	<b>2792 lb</b>	1866 kg	<b>4114 lb</b>	2090 kg	<b>4608 lb</b>

Machine Dimensions  
 ● With General Purpose Bucket

Track Loaders

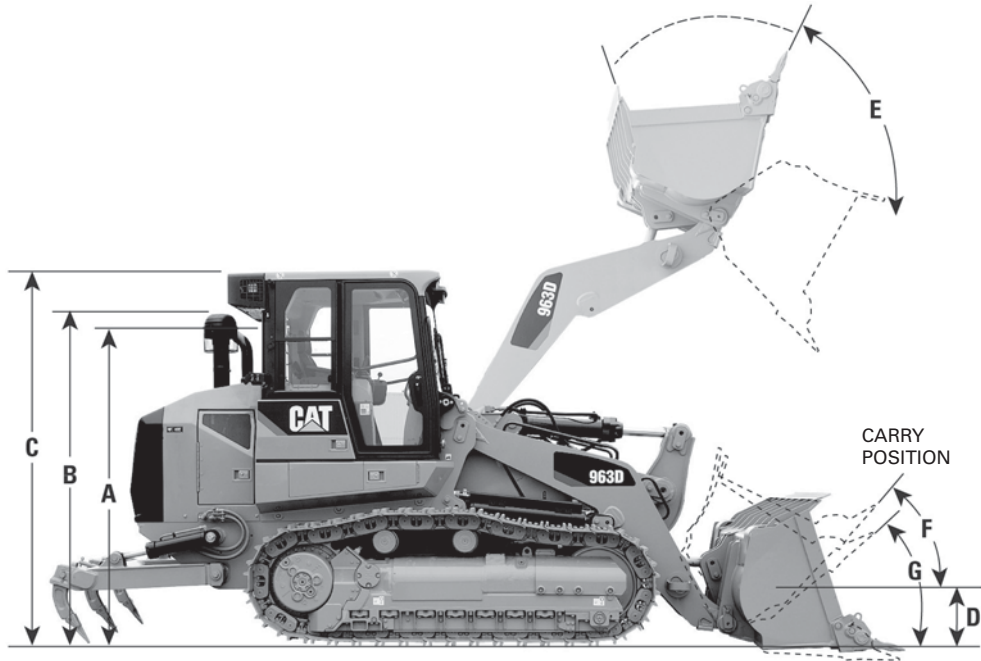

	953K		963K	
A Height to Top of Seat	2610 mm	102.7"	2808 mm	110.6"
B Height to Top of Stack	2803 mm	110.3"	2940 mm	115.7"
C Height to Top of ROPS	3155 mm	124.2"	3325 mm	130.9"
D Hinge Pin Height at Carry Position	421 mm	16.5"	457 mm	18"
E Rollback at Maximum Lift	56°		52°	
F Rollback at Carry Height	48°		50°	
G Rollback at Ground Level	41°		43°	
Grading Angle (Bare Edge)	74°		63°	
Width without Bucket (standard track)	2316 mm	91.2"	2400 mm	94"
(optional track)	2216 mm	87.2"	2300 mm	90.5"
Weight of General Purpose Bucket with Teeth & Segments	1266 kg	2792 lb	1866 kg	4114 lb



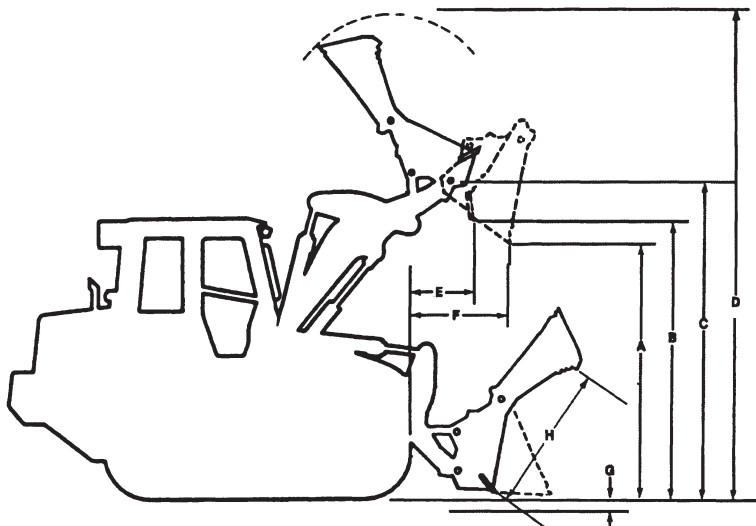

	953D/953K		963D		973D		963K	
<b>A</b> Forward Dump Clearance*	2738 mm	<b>107.7"</b>	3000 mm	<b>118"</b>	3138 mm	<b>123.5"</b>	3000 mm	<b>118"</b>
<b>B</b> Bottom Dump Clearance*	3181 mm	<b>125.2"</b>	3450 mm	<b>135.8"</b>	3670 mm	<b>144"</b>	3450 mm	<b>135.8"</b>
<b>C</b> Hinge Pin Height*	3610 mm	<b>142.1"</b>	3940 mm	<b>155"</b>	4234 mm	<b>166.7"</b>	3940 mm	<b>155"</b>
<b>D</b> Overall Height	4871 mm	<b>192"</b>	5308 mm	<b>209"</b>	5651 mm	<b>222.4"</b>	5308 mm	<b>209"</b>
<b>E</b> Bottom Dump Reach	559 mm	<b>22"</b>	627 mm	<b>24.7"</b>	655 mm	<b>26"</b>	627 mm	<b>24.7"</b>
<b>F</b> Forward Dump Reach*	973 mm	<b>38"</b>	1079 mm	<b>42.5"</b>	—		1079 mm	<b>42.5"</b>
<b>G</b> Digging Depth	142 mm	<b>5.6"</b>	161 mm	<b>6.3"</b>	159 mm	<b>6.26"</b>	161 mm	<b>6.3"</b>
<b>H</b> Bucket Opening	1061 mm	<b>41.7"</b>	1248 mm	<b>49"</b>	—		1248 mm	<b>49"</b>
Reach at 2133 mm (7'0") Height*	1434 mm	<b>56.4"</b>	1598 mm	<b>63"</b>	2327 mm	<b>92"</b>	1598 mm	<b>63"</b>
Tilt Back at Ground Level		<b>42°</b>		<b>45°</b>		<b>45°</b>		<b>45°</b>
Weight of Bucket with Teeth, Segments and Additional Hydraulics	1762 kg	<b>3884.5 lb</b>	2236 kg	<b>4930 lb</b>	3453 kg	<b>7614 lb</b>	2236 kg	<b>4930 lb</b>

\*45° Discharge and full lift.  
 Operator may prefer to tip bucket forward when bottom dumping.

TRACK LOADER	953D/953K		963D		973D		963K	
Ripper-Scarifier Type	Radial		Radial		Parallelogram		Radial	
Dimensions:								
<b>Ripper Shank</b>								
Maximum Penetration Depth	240 mm	<b>9.45"</b>	330 mm	<b>12.99"</b>	397 mm	<b>15.6"</b>	330 mm	<b>12.99"</b>
Maximum Reach at Ground Line (from track to teeth on ground)	1350 mm	<b>53"</b>	1585 mm	<b>62.4"</b>	1938 mm	<b>76.3"</b>	1585 mm	<b>62.4"</b>
Maximum Ground Clearance under Tip (shank pinned in bottom hole)	552 mm	<b>21.7"</b>	667 mm	<b>26.3"</b>	888 mm	<b>34.9"</b>	667 mm	<b>26.3"</b>
Maximum Ramp Angle, Ripper Up (shank pinned in bottom hole)	<b>18°</b>		<b>17°</b>		<b>28.5°</b>		<b>17°</b>	
Shank Section	50 × 109 mm <b>2.0" × 4.3"</b>		58.5 × 138 mm <b>2.3" × 5.4"</b>		74 × 175 mm <b>2.9" × 6.9"</b>		58.5 × 138 mm <b>2.3" × 5.4"</b>	
<b>Ripper Beam</b>								
Overall Width	1950 mm	<b>76.8"</b>	1950 mm	<b>76.7"</b>	2200 mm	<b>86.6"</b>	1950 mm	<b>76.7"</b>
Height	165 mm	<b>6.5"</b>	165 mm	<b>6.5"</b>	216 mm	<b>8.5"</b>	165 mm	<b>6.5"</b>
Length	211 mm	<b>8.3"</b>	211 mm	<b>8.3"</b>	254 mm	<b>10"</b>	211 mm	<b>8.3"</b>
Number of Pockets	<b>3</b>		<b>3</b>		<b>3</b>		<b>3</b>	
Pocket Spacing	900 mm	<b>35.4"</b>	896 mm	<b>35.2"</b>	875 mm	<b>34.4"</b>	896 mm	<b>35.2"</b>
Shank Gauge	1800 mm	<b>70.8"</b>	1792 mm	<b>70.5"</b>	1750 mm	<b>68.9"</b>	1792 mm	<b>70.5"</b>
Track Clearance with Standard Shoe	105.2 mm	<b>4.1"</b>	225.3 mm	<b>8.9"</b>	<b>N/A</b>		225.3 mm	<b>8.9"</b>
Installed Weights:								
Ripper with Standard Shank (1 shank)	581 kg	<b>1281 lb</b>	713 kg	<b>1572 lb</b>	1700 kg	<b>3747 lb</b>	713 kg	<b>1572 lb</b>
Each Additional Shank	25 kg	<b>55 lb</b>	36 kg	<b>79 lb</b>	<b>3 shanks std.</b>		36 kg	<b>79 lb</b>
<b>Ripper Forces*</b>								
Penetration Force at Ground Level	50 kN	<b>11,240 lb</b>	64 kN	<b>14,400 lb</b>	100 kN	<b>22,500 lb</b>	64 kN	<b>14,400 lb</b>
Pryout Force at Maximum Digging Depth	116 kN	<b>26,077 lb</b>	151 kN	<b>33,946 lb</b>	242 kN	<b>54,450 lb</b>	151 kN	<b>33,946 lb</b>

\*These values may vary slightly with different vehicle configurations.

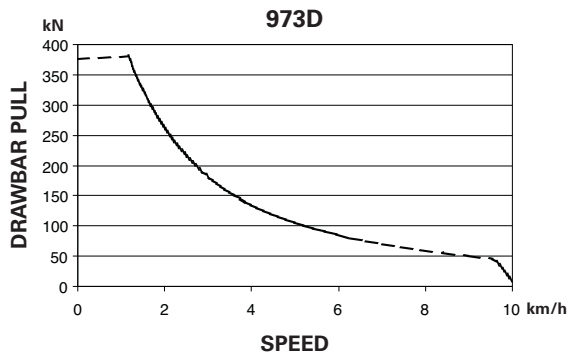
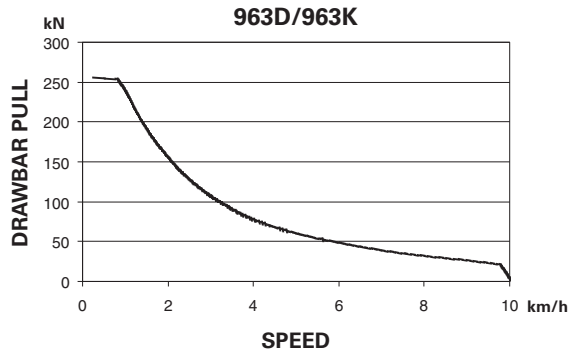
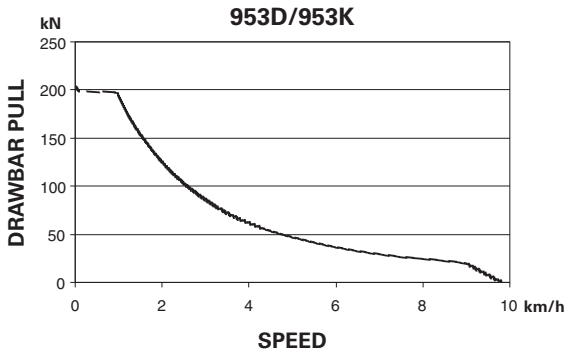

**NOTES:** Usable pull will depend upon weight and traction of equipped tractor.  
 Assumes sufficient machine weight for <5% track slip at POR pressure.  
 Assumes pumps and motors are broken in.  
 Assumes nominal engine power and valve settings.  
 Drawbar pull at track stall will be lower.

## EXTREME SLOPE OPERATION

The maximum fore and aft grade in static condition on which each track loader will maintain proper lubrication is 45 degrees (100%). Consult Operation & Maintenance Manual (if applicable) for POWER TRAIN fluid level overfill requirements for operation on extreme slopes. Extreme slope operation is anytime the slope exceeds 25° (47%).

When working sidehills and slopes, consideration should be given to the following important points:

- Speed of travel — At higher speeds, inertia forces tend to make the track loader less stable.
- Roughness of terrain or surface — Ample allowance should be made where the terrain or surface is uneven.
- Mounted equipment — Buckets, rippers, winches, and other mounted equipment cause the track loader to balance differently.
- Nature of surface — New earthen fills may give way with the weight of the track loader. Rocky surfaces may promote side slipping of track loader.

The ENGINE should never be overfilled with oil. This may lead to rapid overheating. For extreme slope operation, engine oil should be maintained at the full mark.

**NOTE:** Both ENGINE and POWER TRAIN fluid levels should be checked on level ground before working sidehills and slopes.

- Track slippage due to excessive loads — This may cause downhill track to “dig in,” increasing angle of track loader.
- Width of shoes — Wide track shoes tend to decrease “digging in,” hence track loader is more stable.
- Operated equipment — Be aware of the stability and other performance features of the equipment operated by the track loader.
- Keep all attachments or pulled loads low to the ground for optimum stability.

**NOTE:** Safe operation on steep slopes may require special machine maintenance as well as excellent operator skill and proper equipment for the specific application. Consult Operation & Maintenance Manual (if applicable) for proper fluid level requirements.

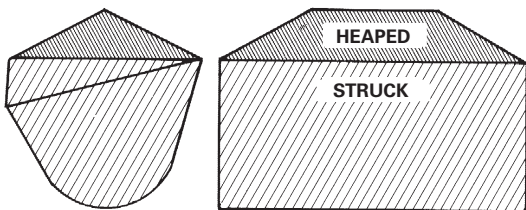
**SAE BUCKET RATING****SAE Bucket Capacities**

*Struck capacity* is that volume contained in a bucket after a load is leveled by drawing a straight edge resting on the cutting edge and the back of the bucket.

*Heaped capacity* is a struck capacity *plus* that additional material that would heap on the struck load at a 2:1 angle of repose with the struck line parallel to the ground.

SAE J742 (Oct. 79) specifies that the addition of any auxiliary spill guard to protect against spillage of material which might injure the operator will not be included in bucket capacity ratings. Buckets with irregular shaped cutting edges (vee edge) the strike plane should be drawn at one-third the distance of the protruding portion of the cutting edge. Cat rock buckets are built with integral see-through rock guards. Cat light material buckets come standard with bolt-on edges. These features which add to actual bucket capacity are included in published ratings.

**Dump Height**

SAE J732 JUN92 specifies that dump height is the vertical distance from the ground to the lowest point of the cutting edge with the bucket hinge pin at maximum height and the bucket at a 45° dump angle. Dump angle is the angle in degrees that the longest flat section of the inside bottom of the bucket will rotate below horizontal.

**Static Tipping Load**

The minimum weight at center of gravity of “SAE Rated” load in bucket which will rotate rear of machine to a point where, on track loaders, front rollers are clear of the track under the following conditions:

- Loader on hard level surface and stationary.
- Unit at standard operating weight.
- Bucket at maximum rollback position.

- Load at maximum forward position during raising cycle.
- Unit with standard equipment as described in specifications unless otherwise noted under the heading.

**Operating Load**

In order to comply with SAE standard J818 MAY87, the operating load for track loaders should not exceed 35% of the Static Tipping load rating. See “Performance Data” of each machine in this handbook for increases to static tipping load by adding cab, counterweights, ripper-scarifier, etc.

**SELECTING A MACHINE****Steps in selecting the proper size loader:**

- Determine production required or desired.
- Determine loader cycle time and cycles per hour. A machine size must be assumed to select a basic cycle time.
- Determine required payload per cycle in loose cubic yards and pounds (meters and kilograms).
- Determine bucket size needed.
- Make machine selection using bucket size and payload as criteria to meet production requirements.
- Compare the loader cycle time used in calculations to the cycle time of the machine selected. If there is a difference, rework the process beginning at step 2.

**1. Production Required**

The production required of a track loader should be slightly greater than the production capability of the other critical units in the earth or material moving system. For example, if a hopper can handle 300 tons per hour, a loader capable of slightly more than 300 tons should be used. Required production should be carefully calculated so the proper machine and bucket selections are made.

**2. Loader Cycle Times**

Material type, pile height, and other factors may improve or reduce production, and should be added to or subtracted from the basic cycle time when applicable.

When hauls are involved, obtain haul and return portions of the cycle from the estimated travel chart (this section). Add the haul and return times to the estimated basic cycle time to obtain total cycle time.

**CYCLE TIME FACTORS**

A basic cycle time (Load, Dump, Maneuver) of 0.25-0.35 minutes is average for a track loader [the basic cycle for large track loaders, 2 m<sup>3</sup> (2.6 yd<sup>3</sup>) and up, can be slightly longer], but variations can be authenticated in the field. The following values for many variable elements are based on normal operations. Adding or subtracting any of the variable times will give the total basic cycle time.

**Estimating Cycle Time**

Cycle time of a track loader needs to be determined to find loads per hour. Total cycle time includes the following segments:

Load Time + Maneuver Time + Travel Time + Dump Time

**Load Time —**

Material	Minutes
Uniform aggregates	0.03-0.05
Moist mixed aggregates	0.03-0.06
Moist loam	0.03-0.07
Soil, boulders, roots	0.04-0.20
Cemented materials	0.05-0.20

**Maneuver Time** — includes basic travel, four changes of direction and turning time, and will be about 0.20 minutes with a competent operator.

**Travel Time** — in a load and carry operation is comprised of haul and return times which can be determined by the travel charts in this section.

**Dump Time** — is dictated by the size and strength of the dump target and varies from 0.00 to 0.10 minutes. Typical dump times into highway trucks are from 0.04 to 0.07 minutes.

**NOTE:** When comparing hydrostatic track loaders with former power shift models (using the production estimating method) two factors must be considered: (1) The hydrostatic track loaders on the average outcycle power shift models by up to 10 percent due to faster machine speed and easier operation. (2) Larger, rear engine hydrostatic track loaders incorporate Z-bar linkage, which provides substantially better bucket fill factors. The degree to which each factor affects estimated production should be left to the user's judgment depending on the particular job application and conditions.

Example: Moist loam is being excavated from a bank and loaded into trucks.

	Minutes
Load — moist loam	0.05
Maneuver Time	0.20
Travel — none required	0.00
Dump	0.05
Total Cycle	0.30 min. or 200 cycles per 60 min. hour

*Minutes added (+)  
or Subtracted (-)  
From Basic Cycle*

**Materials**

- Mixed . . . . . +0.02
- Up to 3 mm (1/8 in) . . . . . +0.02
- 3 mm (1/8 in) to  
20 mm (3/4 in) . . . . . -0.02
- 20 mm (3/4 in) to  
150 mm (6 in) . . . . . 0.00
- 150 mm (6 in) and over . . . . . +0.03 and Up
- Bank or broken . . . . . +0.04 and Up

**Pile**

- Conveyor or Dozer piled  
3 m (10 ft) and up . . . . . 0.00
- Conveyor or Dozer piled  
3 m (10 ft) or less . . . . . +0.01
- Dumped by truck . . . . . +0.02

**Miscellaneous**

- Common ownership of  
trucks and loaders . . . . . Up to -0.04
- Independently owned trucks . . . . . Up to +0.04
- Constant operation . . . . . Up to -0.04
- Inconsistent operation . . . . . Up to +0.04
- Small target . . . . . Up to +0.04
- Fragile target . . . . . Up to +0.05

Using actual job conditions and the above factors, total cycle time can be estimated. Convert total cycle time to cycles per hour.

$$\text{Cycles per hour at 100\% Efficiency} = \frac{60 \text{ Min}}{\text{Total Cycle Time in Minutes}}$$

Job efficiency is an important factor in machine selection. Efficiency is the actual number of minutes worked during an hour. Job efficiency accounts for operator breaks, and other work interruptions. See "Efficiency Considerations" in this section.

- Bucket Fill Factors
  - Recommended Operating Capacities
- ## Loader Production

### Bucket Fill Factors

The following indicates the approximate amounts of material as a percent of rated bucket capacity which will actually be delivered per bucket per cycle. This is known as “Bucket Fill Factor.”

Loose Material	Fill Factor
Mixed Moist Aggregates	95-110%
Uniform Aggregates up to 3 mm (1/8 in)	95-110
3 mm-9 mm (1/8 in-3/8 in)	90-110
12 mm-20 mm (1/2 in-3/4 in)	90-110
24 mm and over (1 in)	90-110
<b>Blasted Rock</b>	
Well	80-95%
Average	75-90
Poor	60-75
<b>Other</b>	
Rock Dirt Mixtures	100-120%
Moist Loam	100-120
Soil, Boulders, Roots	80-100
Cemented Materials	85-100

Fill factors on track loaders are affected by bucket penetration, breakout force, rack back angle, bucket profile and ground engaging tools such as bucket teeth and segments or bolt-on replaceable cutting edges.

### GENERAL PURPOSE BUCKET W/TEETH & SEGMENTS MAXIMUM OPERATING CAPACITIES

MODEL	GENERAL PURPOSE BUCKET SIZE		MAXIMUM OPERATING CAPACITY	
	m <sup>3</sup>	yd <sup>3</sup>	kg	lb
953D/953K	1.85	2.4	3182	7015
963D/963K	2.45	3.2	4214	9290
973D	3.21	4.2	5521	12,174

### LOADER PRODUCTION

Loader production equals quantity of material the bucket carries per load × number of bucket loads per hour.

#### Estimating Bucket Load

The quantity of material in a loader bucket is estimated by two methods, depending on whether the material being loaded is in a loose or bank state.

1. When the material is loose, as in stockpile loading, the bucket load is estimated in loose meters (or cubic yards) by a Bucket Fill Factor (see Tables Section or chart following this discussion). The quantity of material is determined as follows:

$$\text{Rated Bucket Capacity} \times \text{Bucket Fill Factor} = \text{Bucket Payload in Loose m}^3 \text{ (yd}^3\text{)}$$

For example, a 973 with a 3.2 m<sup>3</sup> (4.2 yd<sup>3</sup>) General Purpose bucket loading moist loam material will carry:

$$3.2 \text{ m}^3 \times 1.15 = 3.68 \text{ loose cubic meters}$$

$$(4.2 \text{ yd}^3 \times 1.15 = 4.83 \text{ loose cubic yards})$$

Once the potential bucket load has been determined, check the static tipping load ratings on the specific machine to determine if bucket load is in fact a safe operating load. (*Safe operating load as defined by SAE for track loaders should not exceed 35% of static tipping load.*)

Productivity in many applications is measured in tons. See Tables Section for material densities if conversion to tons is desired.

2. When material is in the bank state, as in excavation, productivity is measured in bank meters (cubic yards). Bucket load in Bm<sup>3</sup> (BCY) is estimated by applying one of the load factors from the Tables section to convert the excavated material in the bucket from Bm<sup>3</sup> (BCY) to Lm<sup>3</sup> (LCY) to allow for the digging and carrying characteristics of the material. The quantity of excavated material a bucket carries is then determined as follows:

$$\text{Rated Bucket Capacity} \times \text{Load Factor} \times \text{Bucket Fill Factor} = \text{Bucket Payload in Bm}^3 \text{ (BCY)}$$

Example: a 953D with a 1.85 m<sup>3</sup> (2.4 yd<sup>3</sup>) General Purpose bucket loading wet loam earth from bank:

$$1.85 \text{ m}^3 \times 0.79 \times 1.15 = 1.68 \text{ Bm}^3$$

$$(2.4 \text{ yd}^3 \times 0.79 \times 1.15 = 2.18 \text{ BCY})$$

### Estimating Production

Machine and job considerations include:

- Machine model and bucket size
- Material type, particle size, density and load factor (see Tables Section)
- Bucket fill factor
- Haul distance
- Underfoot conditions
- Altitude
- Dump target size, height, and type

*Example:*

**Conditions —**

Machine	953D
Bucket size	1.85 m <sup>3</sup> (2.4 yd <sup>3</sup> )
Material	Moist Loam
Bucket fill factor	1.15
Haul length	30 m (100 ft)
Dump target	Pile
Travel in forward speed	

**Cycle Time**

	<b>Minutes</b>
Load time	0.15
Maneuver time	0.20
Travel time (from curves)	0.40
Dump time	<u>0.05</u>
Total	0.80

**Loads Per Hour —**

$$\frac{60 \text{ min/hr}}{0.80 \text{ min/cycle}} = 75 \text{ cycles per hour @ } 100\% \text{ efficiency}$$

**Load Per Cycle —**

$$\begin{aligned}
 1.85 \text{ m}^3 \times 1.15 \text{ BFF} &= 2.13 \text{ Lm}^3 \times 0.81 \text{ LF} \\
 &= 1.72 \text{ Bm}^3 \\
 (2.4 \text{ yd}^3 \times 1.15 \text{ BFF} &= 2.76 \text{ LCY} \times 0.81 \text{ LF} \\
 &= 2.24 \text{ BCY})
 \end{aligned}$$

**Hourly Production —**

$$\begin{aligned}
 1.72 \text{ Bm}^3 \times 75 \text{ cycles/h} &= 129 \text{ Bm}^3/\text{h} \\
 (2.24 \text{ BCY} \times 75 \text{ cycles/hr} &= 168 \text{ BCY/hr})
 \end{aligned}$$

More accurate production estimates can be made by recording actual machine cycle times in the same or similar application. Then visually verify the approximate bucket fill factor.

### Efficiency Considerations

Loader capacity should always be matched to peak production requirements of the job. Actual “on-the-job” loader productivity will be influenced by factors such as operator skill, personal delays, job layout and other delays. Experience and knowledge of local conditions will be the best indicators of actual job efficiency.

Operation	Working Hour	Efficiency Factor
Day	50 min/Hr	0.83

### An Alternative Machine Selection Method

Another method of selecting the right Track Loader and bucket to meet production requirements is by use of the nomographs on the following pages. The method is quicker and easier than the preceding example because it does not require as many calculations, yet the accuracy is about the same within the normal limits of input data.

Be careful when entering and reading data from the nomographs because some scales increase from bottom to top, while others are the reverse. Do not be overly concerned with the precision as affected by pencil line width or reading to the hundredth of a m<sup>3</sup> (yd<sup>3</sup>). Remember that bucket fill factor, material density, and cycle time are at best close estimates.

*Example problem*

A track loader must produce 200 Lm<sup>3</sup> (262 LCY) per hour. Estimated cycle time is 0.5 minutes, working 50 minutes per hour. Bucket fill factor is 110% and the material density is 1600 kg/Lm<sup>3</sup> (2700 lb/LCY).

Determine bucket size, machine model and hourly production in tons and yards.

### Solution

At full efficiency, it will cycle 120 times per hour. Since only an average 50 minutes are available, only 100 cycles will be completed per hour.

Starting on Scale A at 100 cycles per hour draw a straight line intersecting 200 m<sup>3</sup>/hr (262 yd<sup>3</sup>/hr) on Scale B and continuing the line on to Scale C giving 2.0 m<sup>3</sup> (2.62 yd<sup>3</sup>) required payload.

Follow steps 1 through 7 on the next two pages.





# Track Loaders

## Production and Machine Selection Nomograph

- To find required bucket payload and bucket size

- 1) Enter Scale A cycles per hour (100) and B hourly production 200 m<sup>3</sup>/hr (262 yd<sup>3</sup>/hr).
- 2) Connect A and B and extend to C to find required payload 2.0 m<sup>3</sup> (2.62 yd<sup>3</sup>).
- 3) Connect C to bucket fill factor on Scale D (110%) and extend to E to find required bucket size 1.8 m<sup>3</sup> (2.35 yd<sup>3</sup>).
- 4) Transfer Scale A and C readings to nomograph on following page.

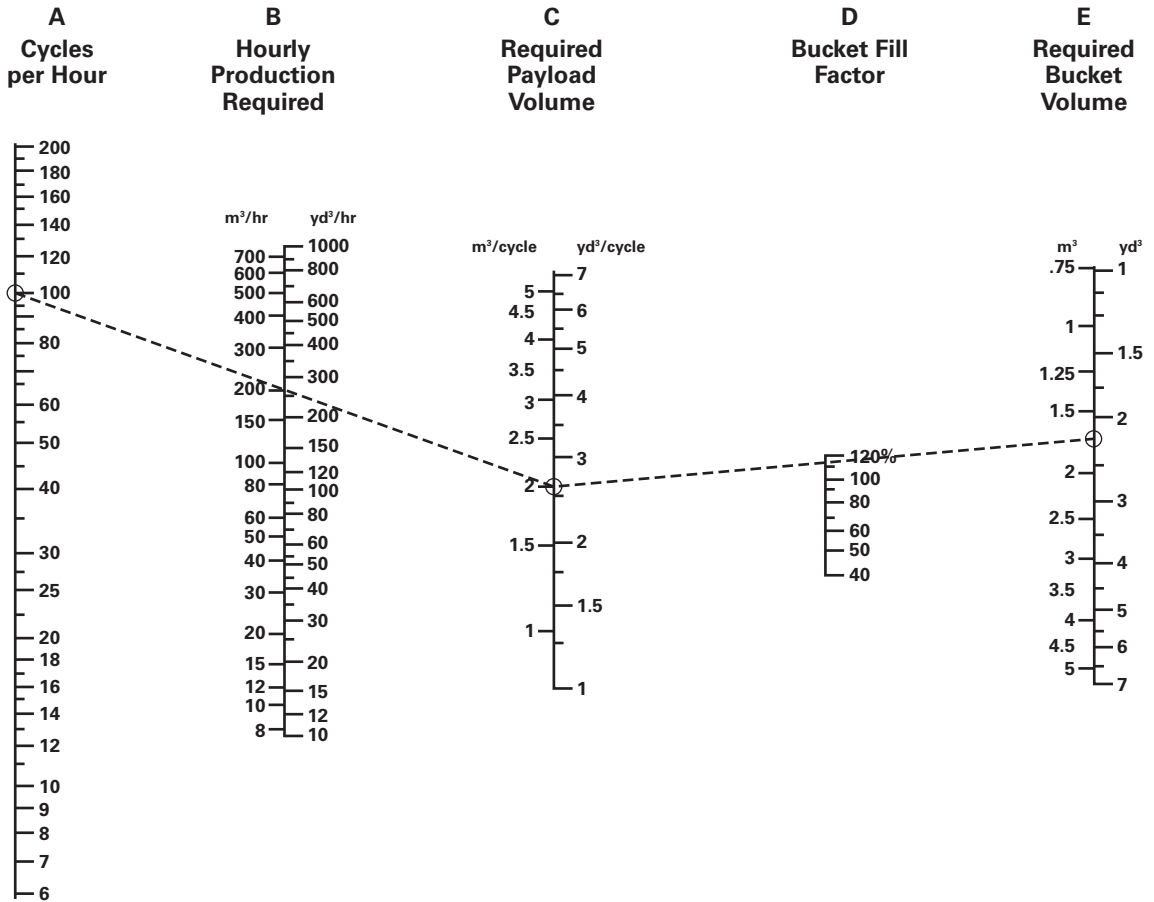

# Production and Machine Selection Nomograph

# Track Loaders

- To find payload weight for stability and output in tons per hour

- 5) Connect C 1.8 m<sup>3</sup> (2.35 yd<sup>3</sup>) to F 1600 kg/m<sup>3</sup> (2700 lb/yd<sup>3</sup>) and extend to G to find payload weight 2880 kg (6345 lb).
- 6) Compare G bucket payload weight 2880 kg (6345 lb) with maximum operating capacities table in this section to see if the 1.85 m<sup>3</sup> (2.4 yd<sup>3</sup>) bucket can handle the desired payload. Table indicates the 953D with a

- 1.85 m<sup>3</sup> (2.4 yd<sup>3</sup>) bucket equipped with bolt-on cutting edge or teeth and segments has a greater operating capacity of 3343 kg (7370 lb), therefore stability is okay.
- 7) Extend Scale G reading 2880 kg (6345 lb) through Scale A (100) to Scale I to find tons per hour 288 metric ton/hr (317 U.S. ton/hr).

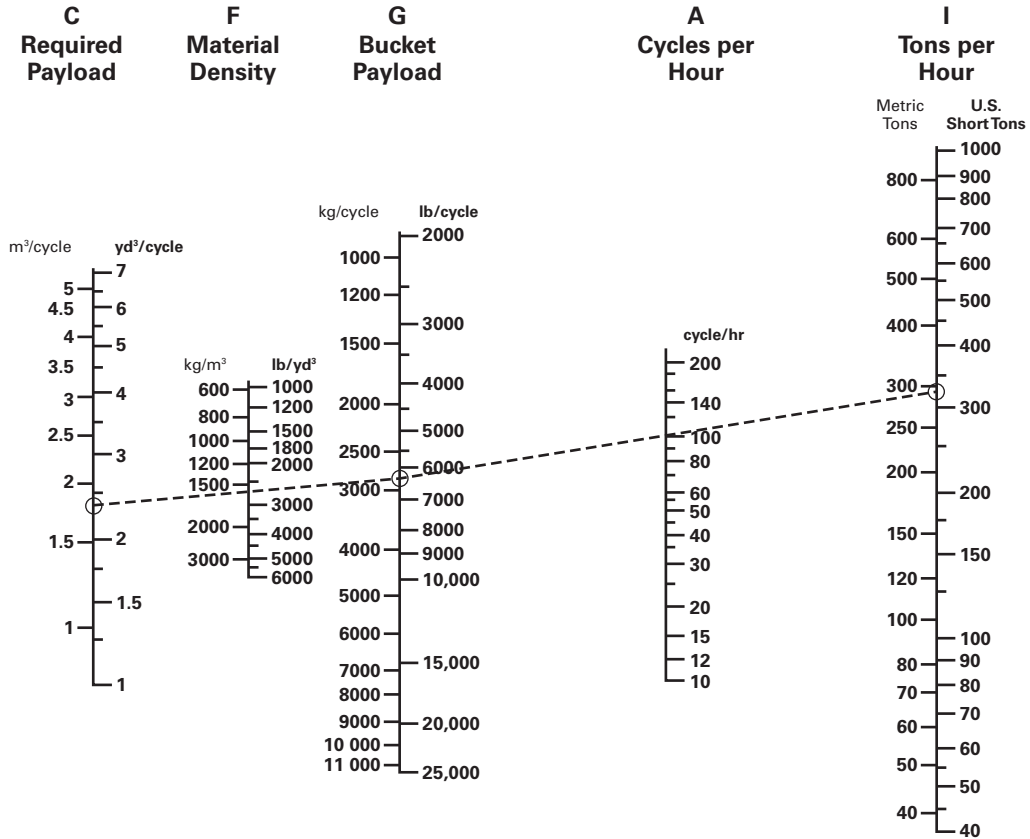

953D/953K

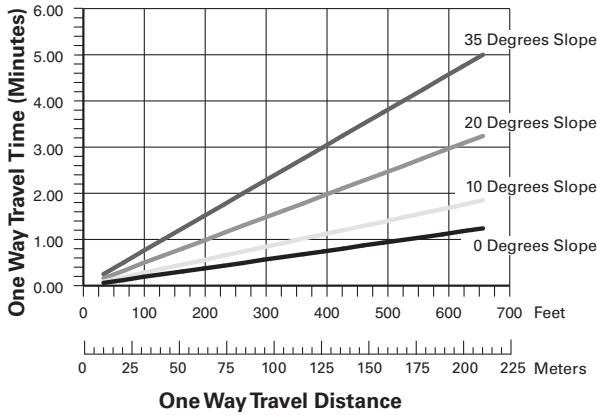

963D/963K

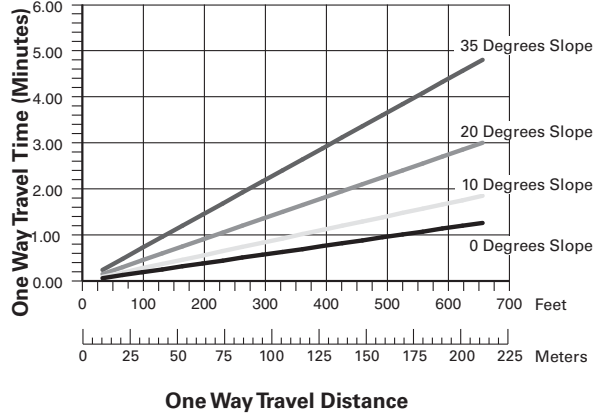

973D

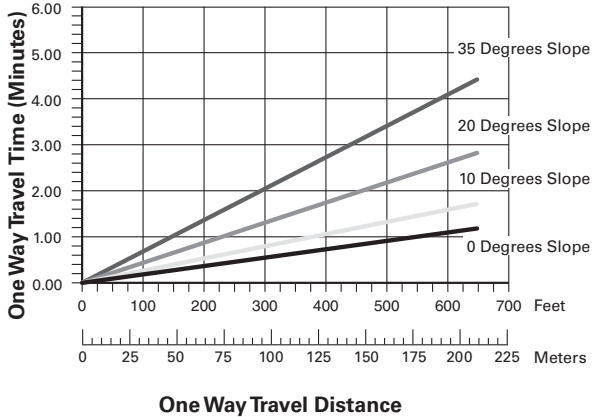

TRAVEL TIME CHARTS

Conditions:

- No grades.
- Speeds loaded and empty essentially the same.
- Bucket position constant during travel.
- Travel encountered in maneuver portion of cycle not included.
- Acceleration time accounted for in maneuver time.

Travel Time (in minutes) =

$$Metric - \frac{\text{number of meters traveled}}{\text{speed (in km/h)} \times 16.67}$$

$$English - \frac{\text{number of feet traveled}}{\text{speed (in mph)} \times 88}$$

KEY

953D/953K — Hydrostatic top speed both forward and reverse 10 km/h (6.2 mph)

963D/963K — Hydrostatic top speed both forward and reverse 10 km/h (6.2 mph)

973D — Hydrostatic top speed both forward and reverse 11 km/h (6.83 mph)

Production Estimating Table  
 ● m<sup>3</sup> or yd<sup>3</sup>/60 min. hour  
 ● Estimated bucket payload in  
 bank m<sup>3</sup> or yd<sup>3</sup>

**Track Loaders**

Bucket Size (m <sup>3</sup> or yd <sup>3</sup> )		1.0	1.5	2.0	2.5	3.0	3.5	4.0	4.5	5.0
Cycle Time Hundredths of a minute	Cycles Per Hr	Unshaded area indicates average work range								
		0.25	240	240	360	480	600	720	840	960
0.30	200	200	300	400	500	600	700	800		
0.35	171	171	257	342	428	513	599	684	769	
0.40	150	150	225	300	375	450	525	600	675	750
0.45	133	133	200	268	332	400	466	530	600	665
0.50	120	120	180	240	300	360	420	480	540	600
0.55	109	109	164	218	272	328	382	436	490	545
0.60	100	100	150	200	250	300	350	400	450	600
0.65	92	92	138	184	230	276	322	368	416	460

<b>Work Tools</b>	<b>953D/953K</b>	<b>963D/963K</b>	<b>973D</b>
Fusion™ Coupler	X (953K only)	X	
Quick Coupler	X	X	X
Fusion General Purpose Bucket	X (953K only)	X	
General Purpose (GP) bucket	X	X	X
GP bucket with trash rack	X	X	X
MP bucket with trash rack	X	X	X
Landfill bucket	X	X	X
Landfill Multi-purpose	X	X	X
Multi-purpose (MP) bucket	X	X	X
Trim blade	X	X	X
Slag bucket			X
Fusion Pallet Forks	X (953K only)	X	
Forks (for QC or bucket)	X	X	X
Material handling arm	X	X	X
Loader rake	X	X	X
Top-Clamp bucket	X		X
Side Dump bucket	X	X	X

### New Fusion Coupler System for 953K, 963D and 963K Track Loaders

The proven Fusion Coupler System is available for 953K, 963D and 963K machines. Key durability benefits experienced with the wheel loader platform are now available for the 953K, 963D and 963K Track Loader.

The biggest gain for the track loader user is durability; the Fusion coupler endures like no other. Patented dual wedge locks pull the tool tight to the coupler and hold it there for a solid, rattle-free fit. No rattle means no wear, so tools last longer. The wedge lock is built to stay tight even after thousands of tool changes. This coupler is built to be as tough as the linkage itself, for trouble-free performance day in and day out.

The 953K, 963D and 963K Fusion Coupler is supported by a set of tools:



**General Purpose Buckets** provide good all-around performance for stockpiling, re-handling, excavating and bank loading. A wide bucket is available for use with a machine that has wide gauge tracks.



**Multi-Purpose Buckets** have a unique four-way action that can load, strip top soil, bulldoze, clamp pipe or large chunks of concrete, clean up debris and many other tasks.



**Pallet Forks** are an essential tool on construction job sites. Cat Fusion Pallet Forks can be configured to allow the tines to either swing or stay in a fixed position.

### Fusion Interchangeability

The Fusion Coupler for the 953K, 963D and 963K is compatible with most of the Fusion tools for wheel loaders, allowing interchangeability. However, common sense must be used as machine power envelopes and use profiles are very different for each machine platform.

Care must be taken to get the best performance while taking advantage of tool interchangeability. While all Fusion couplers can pick up any Fusion tool, some tools are less useful when used on a different type of carrier than their design intent.

For compatibility questions, contact Cat Work Tools.

## SHOE OPTIONS



① **Double Grouser Shoes**

- **Extreme service shoes** are available which have more hardened wear material for longer wear life and higher impact applications.



② **Trapezoidal Center Hole Shoes**



③ **Single Grouser Shoes**

- **Wider shoes** are also available to reduce ground pressure in soft underfoot conditions.



④ **Chopper Shoes**

Other shoe options are available. Consult a Cat dealer for more information.

## SYSTEMONE SHOES



**Double Grouser Shoes**

- Work best in applications that require less penetration and traction.
- Recommended for applications that require better turning capability and less ground disturbance.
- Feature two or three short grousers instead of one tall grouser.

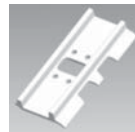

**Center Hole Shoes**

- Work best in applications where packing causes the track to tighten. They are recommended for applications with large amounts of debris what tend to pack in the track.
- Reduces extricable packing between the shoe and the bushing since they allow the sprocket to punch out dirt and debris.

# TRACK-TYPE TRACTORS

## Hydraulic Controls

## Bulldozers

## Rippers and Winches

### CONTENTS

#### TRACK-TYPE TRACTORS

Features . . . . .	19-1
Specifications . . . . .	19-3
Power Shift Drawbar Pull vs. Ground Speed Curves . . . . .	19-18
Power Shift Travel Speeds . . . . .	19-24
Ground Pressures . . . . .	19-26
Extreme Slope Operation . . . . .	19-28

#### HYDRAULIC CONTROLS

Features . . . . .	19-29
Specifications . . . . .	19-30

#### BULLDOZERS

Features . . . . .	19-33
Summary of Blade Options . . . . .	19-34
Blade Selection . . . . .	19-36
General Dimensions (Tractor and Blade) . . . . .	19-39
SAE Blade Capacity Definition . . . . .	19-39
Blade Specifications . . . . .	19-40
Estimating Production Off-the-Job . . . . .	19-50
Job Condition Correction Factors . . . . .	19-55
Measuring Production On-the-Job . . . . .	19-56
Attachments . . . . .	19-56
Special Attachments . . . . .	19-57

#### RIPPERS

Features . . . . .	19-59
Ripper Specification Diagrams	
Adjustable Parallelogram Ripper . . . . .	19-60
Radial Ripper . . . . .	19-62
Fixed Parallelogram Ripper . . . . .	19-62
Specifications	
Track-Type Tractors . . . . .	19-63
Tip Selection . . . . .	19-73
Estimating Ripping Production . . . . .	19-73
Seismic Wave Velocity Charts . . . . .	19-76
Estimated Ripper Production Graphs . . . . .	19-81

#### WINCHES

##### PACCAR

Features . . . . .	19-84
Physical Specifications . . . . .	19-85
Operating Specifications . . . . .	19-95

##### Allied

Features . . . . .	19-99
Physical Specifications . . . . .	19-100
Operating Specifications . . . . .	19-107

#### TRACK-TYPE TRACTORS

##### Features:

- **Cat® Diesel Engines** provide the power, high torque rise, reliability and performance you can depend on.
- **HEUI™** on D6R and D7R increases fuel efficiency, reduces smoke, improves cold starting and enhances diagnostic capabilities.
- **Mechanical Electronic Unit Injector (MEUI™)** on D8T, D9T, D10T2 and D11T excels in its ability to control injection pressure over the entire engine operating speed range. It combines the technical advancement of an electronic control system with the simplicity of direct mechanically controlled unit fuel injection. These features allow the engine to have complete control over injection timing, duration, and pressure.
- **Common Rail fuel injection system** on D3K2, D4K2, D5K2, D6K2, D5R2, D6N, D6T and D7E machines; optimizes performance and fuel consumption, minimizes heat rejection, and lowers emissions.



- **Oil cooled steering clutches and brakes** standard on D9R, D10T2 and D11T.
- **Finger Tip Controls (FTC)** of transmission, steering clutches and brakes on D10T2 and D11T.
- **Differential steering** allows infinitely variable turning radius. Standard on the D5R2, D6N, D6R2, D6T, D7R, D7E, D8R, D8T and D9T, allows the tractor to make a “power turn” keeping both tracks working for more traction and higher performance.
- **Electronic Hydrostatic Power Train System** on D3K2 through D6K2 allows power turns, stepless speed range, smooth modulation, dynamic hydrostatic braking, superior maneuverability and excellent controllability.
- **Electric Drive Power Train System** on D7E allows stepless speed range, smooth modulation, and excellent efficiency. When coupled with differential steer it provides superior maneuverability with locked-track pivot turn capability and excellent controllability.
- **Combined hand lever steering** located left of operator provides easier operation on D9R.
- **Standard Tractors** designed for heavy dozing and general grading.
- **XL Tractor D6T** offers higher horsepower and longer roller frames for increased finish grading capability, flotation and productivity.
- **Extra Wide (XW) gauge** on D6T length roller frame provides wider shoes for greater flotation and stability for steep slope grading.
- **Sealed and Lubricated Track** reduces pin and bushing wear for lower undercarriage repair costs. Sealed and lubricated track is standard on the D3K2, D4K2, and D5K2 while heavy duty track chain is available on D5R, D6K2, D6N, D6T, and D7E improves wear life and reduces pin/bore stretching and cracking.
- **SystemOne™ Undercarriage** extends undercarriage system life, improves reliability, and reduces owning and operating costs. Optional on D6T (all sources), D5R2, D6K2, D6N, D6R2, optional on D8T and D8R (all sources), D3K2, D4K2, D5K2.
- **Elevated sprockets** (not on D6K2 or D7E) eliminate final drive stress induced by roller frame movement and ground impact loads. Final drives pull chain only. Seals moved up out of dirt, sand and water for longer life. Blade visibility improved because operator sits higher.
- **Resilient mounted bogie undercarriage** on D8R, D8T, D9T, D10T2 and D11T reduces shock transmitted to tractor. Allows track to conform to rough ground for better traction.
- **Solid mounted undercarriage** standard on D3K2 through D5K2 provides stable platform for low impact, and high abrasion applications. Provides optimum finish grading performance.
- **Oscillating undercarriage** on D6K2 through D7E and optional on the D8R and D8T decreases ground shock to the machine and provides a smoother, more comfortable ride for the operator.
- **Accessible modular design** on D6N XL and up greatly reduces drive train removal and installation time resulting in reduced repair costs.
- **Tag link** on D7R, D8R/D8T and up; L-shaped push arms on D6N, D6T and D7E. Both designs allow closer mounting of dozer blades. This reduces total tractor length, improves maneuverability, balance, blade penetration and pryout.
- **Low ground pressure (LGP)** tractors offer greater flotation in soft, swampy conditions. Available on D3K2 through D8T.

MODEL	D3K2 XL		D3K2 LGP		D3K2 XL		D3K2 LGP	
Emission Standards	U.S. EPA Tier 3/ EU Stage IIIA/ Japan 2006 (Tier 3) equivalent <sup>1</sup>		Tier 3/Stage IIIA/ Japan 2006 (Tier 3) equivalent <sup>1</sup>		Tier 4 Final/Stage IV/ Japan 2014 (Tier 4 Final)		Tier 4 Final/Stage IV/ Japan 2014 (Tier 4 Final)	
Flywheel Power	55.2 kW	<b>74 hp</b>	55.2 kW	<b>74 hp</b>	59.7 kW	<b>80 hp</b>	59.7 kW	<b>80 hp</b>
Operating Weight <sup>2</sup>	7795 kg	<b>17,185 lb</b>	8093 kg	<b>17,842 lb</b>	7958 kg	<b>17,544 lb</b>	8403 kg	<b>18,525 lb</b>
Engine Model	<b>C4.4 ACERT™</b>		<b>C4.4 ACERT</b>		<b>C4.4 ACERT</b>		<b>C4.4 ACERT</b>	
Rated Engine RPM	<b>1900</b>		<b>1900</b>		<b>2200</b>		<b>2200</b>	
No. of Cylinders	<b>4</b>		<b>4</b>		<b>4</b>		<b>4</b>	
Bore	105 mm	<b>4.13"</b>	105 mm	<b>4.13"</b>	105 mm	<b>4.13"</b>	105 mm	<b>4.13"</b>
Stroke	127 mm	<b>5.0"</b>	127 mm	<b>5.0"</b>	127 mm	<b>5.0"</b>	127 mm	<b>5.0"</b>
Displacement	4.4 L	<b>269 in<sup>3</sup></b>	4.4 L	<b>269 in<sup>3</sup></b>	4.4 L	<b>269 in<sup>3</sup></b>	4.4 L	<b>269 in<sup>3</sup></b>
Track Rollers (Each Side)	<b>6</b>		<b>6</b>		<b>6</b>		<b>6</b>	
Width of Standard Track Shoe	406 mm	<b>16"</b>	635 mm	<b>25"</b>	406 mm	<b>16"</b>	635 mm	<b>25"</b>
Length of Track on Ground	2095 mm	<b>83"</b>	2095 mm	<b>83"</b>	2248 mm	<b>89"</b>	2248 mm	<b>89"</b>
Ground Contact Area (w/Std. Shoe)	17 011 cm <sup>2</sup>	<b>2637 in<sup>2</sup></b>	26 607 cm <sup>2</sup>	<b>4124 in<sup>2</sup></b>	18 254 cm <sup>2</sup>	<b>2848 in<sup>2</sup></b>	28 550 cm <sup>2</sup>	<b>4425 in<sup>2</sup></b>
Track Gauge	1495 mm	<b>59"</b>	1725 mm	<b>68"</b>	1495 mm	<b>59"</b>	1725 mm	<b>68"</b>
GENERAL DIMENSIONS:								
Height (To Top of ROPS)	2763 mm	<b>108.8"</b>	2763 mm	<b>108.8"</b>	2763 mm	<b>108.8"</b>	2763 mm	<b>108.8"</b>
Overall Length (with P blade)	4266 mm	<b>168"</b>	4255 mm	<b>167.6"</b>	4266 mm	<b>168"</b>	4266 mm	<b>168"</b>
(without Blade)	3275 mm	<b>128.9"</b>	3275 mm	<b>128.9"</b>	3275 mm	<b>128.9"</b>	3275 mm	<b>128.9"</b>
Width (w/o Trunnion and Blade — Std. Shoe)	1901 mm	<b>74.8"</b>	2360 mm	<b>92.9"</b>	1901 mm	<b>74.8"</b>	2360 mm	<b>92.9"</b>
Ground Clearance	332 mm	<b>13"</b>	332 mm	<b>13"</b>	332 mm	<b>13"</b>	332 mm	<b>13"</b>
Blade Types and Widths:								
VPAT, Straight	2646 mm	<b>104.1"</b>	3149 mm	<b>124.0"</b>	2646 mm	<b>104.1"</b>	3149 mm	<b>124"</b>
VPAT, Angled 25°	2417 mm	<b>95.1"</b>	2874 mm	<b>113"</b>	2417 mm	<b>95.1"</b>	2874 mm	<b>113"</b>
Fuel Tank Refill Capacity	195 L	<b>51.5 U.S. gal</b>	195 L	<b>51.5 U.S. gal</b>	195 L	<b>51.5 U.S. gal</b>	195 L	<b>51.5 U.S. gal</b>
DEF Tank Refill Capacity	—		—		19 L	<b>5 U.S. gal</b>	19 L	<b>5 U.S. gal</b>

<sup>1</sup> Meets Tier 3/Stage IIIA/Japan 2006 (Tier 3) equivalent emission standards.

<sup>2</sup> Operating weight includes ROPS canopy, operator, lubricants, coolant, full fuel tank, hydraulic controls and fluids, back-up alarm, seat belts, lights, rigid drawbar, front pull device and standard service crankcase guard.

MODEL	D4K2 XL		D4K2 LGP		D4K2 XL		D4K2 LGP	
Emission Standards	Tier 3/Stage IIIA/ Japan 2006 (Tier 3) equivalent <sup>1</sup>		Tier 3/Stage IIIA/ Japan 2006 (Tier 3) equivalent <sup>1</sup>		Tier 4 Final/Stage IV/ Japan 2014 (Tier 4 Final)		Tier 4 Final/Stage IV/ Japan 2014 (Tier 4 Final)	
Flywheel Power	62.6 kW	<b>84 hp</b>	62.6 kW	<b>84 hp</b>	68.8 kW	<b>92 hp</b>	68.8 kW	<b>92 hp</b>
Operating Weight <sup>2</sup>	8147 kg	<b>17,961 lb</b>	8501 kg	<b>18,742 lb</b>	8201 kg	<b>18,080 lb</b>	8510 kg	<b>18,761 lb</b>
Engine Model	<b>C4.4 ACERT</b>		<b>C4.4 ACERT</b>		<b>C4.4 ACERT</b>		<b>C4.4 ACERT</b>	
Rated Engine RPM	<b>1900</b>		<b>1900</b>		<b>2200</b>		<b>2200</b>	
No. of Cylinders	<b>4</b>		<b>4</b>		<b>4</b>		<b>4</b>	
Bore	105 mm	<b>4.13"</b>	105 mm	<b>4.13"</b>	105 mm	<b>4.13"</b>	105 mm	<b>4.13"</b>
Stroke	127 mm	<b>5.0"</b>	127 mm	<b>5.0"</b>	127 mm	<b>5.0"</b>	127 mm	<b>5.0"</b>
Displacement	4.4 L	<b>269 in<sup>3</sup></b>	4.4 L	<b>269 in<sup>3</sup></b>	4.4 L	<b>269 in<sup>3</sup></b>	4.4 L	<b>269 in<sup>3</sup></b>
Track Rollers (Each Side)	<b>7</b>		<b>7</b>		<b>7</b>		<b>7</b>	
Width of Standard Track Shoe	460 mm	<b>18"</b>	635 mm	<b>25"</b>	460 mm	<b>18"</b>	635 mm	<b>25"</b>
Length of Track on Ground	2248 mm	<b>89"</b>	2248 mm	<b>89"</b>	2248 mm	<b>89"</b>	2248 mm	<b>89"</b>
Ground Contact Area (w/Std. Shoe)	20 682 cm <sup>2</sup>	<b>3206 in<sup>2</sup></b>	28 550 cm <sup>2</sup>	<b>4425 in<sup>2</sup></b>	20 862 cm <sup>2</sup>	<b>3206 in<sup>2</sup></b>	28 550 cm <sup>2</sup>	<b>4425 in<sup>2</sup></b>
Track Gauge	1550 mm	<b>61"</b>	1725 mm	<b>68"</b>	1550 mm	<b>61"</b>	1725 mm	<b>68"</b>
GENERAL DIMENSIONS:								
Height (To Top of ROPS)	2763 mm	<b>108.8"</b>	2763 mm	<b>108.8"</b>	2763 mm	<b>108.8"</b>	2763 mm	<b>108.8"</b>
Overall Length (with P blade (without Blade)	4274 mm	<b>168"</b>	4266 mm	<b>168"</b>	4266 mm	<b>168"</b>	4266 mm	<b>168"</b>
Width (w/o Trunnion and Blade — Std. Shoe)	3275 mm	<b>128.9"</b>	3275 mm	<b>128.9"</b>	3275 mm	<b>128.9"</b>	3275 mm	<b>128.9"</b>
Ground Clearance	332 mm	<b>13"</b>	332 mm	<b>13"</b>	332 mm	<b>13"</b>	332 mm	<b>13"</b>
Blade Types and Widths:								
VPAT, Straight	2782 mm	<b>109.5"</b>	3149 mm	<b>124.0"</b>	2782 mm	<b>109.5"</b>	3149 mm	<b>124"</b>
VPAT, Angled 25°	2542 mm	<b>100.1"</b>	2874 mm	<b>113"</b>	2542 mm	<b>100.1"</b>	2874 mm	<b>113"</b>
Fuel Tank Refill Capacity	195 L	<b>51.5 U.S. gal</b>	195 L	<b>51.5 U.S. gal</b>	195 L	<b>51.5 U.S. gal</b>	195 L	<b>51.5 U.S. gal</b>
DEF Tank Refill Capacity	—		—		19 L	<b>5 U.S. gal</b>	19 L	<b>5 U.S. gal</b>

<sup>1</sup> Meets Tier 3/Stage IIIA/Japan 2006 (Tier 3) equivalent emission standards.

<sup>2</sup> Operating weight includes ROPS canopy, operator, lubricants, coolant, full fuel tank, hydraulic controls and fluids, back-up alarm, seat belts, lights, rigid drawbar, front pull device and standard service crankcase guard.

MODEL	D5K2 XL		D5K2 LGP		D5K2 XL		D5K2 LGP	
Emission Standards	Tier 3/Stage IIIA/ Japan 2006 (Tier 3) equivalent <sup>1</sup>		Tier 3/Stage IIIA/ Japan 2006 (Tier 3) equivalent <sup>1</sup>		Tier 4 Final/Stage IV/ Japan 2014 (Tier 4 Final)		Tier 4 Final/Stage IV/ Japan 2014 (Tier 4 Final)	
Flywheel Power:								
Hydrostatic	71.6 kW	96 hp	71.6 kW	96 hp	77.6 kW	104 hp	77.6 kW	104 hp
Operating Weight: <sup>2</sup>								
Hydrostatic	9408 kg	20,741 lb	9683 kg	21,347 lb	9314 kg	20,534 lb	9646 kg	21,266 lb
Engine Model	C4.4 ACERT		C4.4 ACERT		C4.4 ACERT		C4.4 ACERT	
Rated Engine RPM	1900		1900		2100		2100	
No. of Cylinders	4		4		4		4	
Bore	105 mm	4.13"	105 mm	4.13"	105 mm	4.13"	105 mm	4.13"
Stroke	127 mm	5.0"	127 mm	5.0"	127 mm	5.0"	127 mm	5.0"
Displacement	4.4 L	269 in <sup>3</sup>	4.4 L	269 in <sup>3</sup>	4.4 L	269 in <sup>3</sup>	4.4 L	269 in <sup>3</sup>
Track Rollers (Each Side)	7		7		7		7	
Width of Standard Track Shoe	510 mm	20"	660 mm	26"	510 mm	20"	660 mm	26"
Length of Track on Ground	2310 mm	91"	2310 mm	91"	2310 mm	91"	2310 mm	91"
Ground Contact Area (w/Std. Shoe)	23 562 cm <sup>2</sup>	3652 in <sup>2</sup>	30 492 cm <sup>2</sup>	4726 in <sup>2</sup>	23 562 cm <sup>2</sup>	3652 in <sup>2</sup>	30 492 cm <sup>2</sup>	4726 in <sup>2</sup>
Track Gauge	1600 mm	63"	1750 mm	69"	1600 mm	63"	1750 mm	69"
GENERAL DIMENSIONS:								
Height (To Top of ROPS Canopy)	2769 mm	109.0"	2769 mm	109.0"	2769 mm	109.0"	2769 mm	109.0"
Height (To Top of ROPS Cab)	2769 mm	109.0"	2769 mm	109.0"	2769 mm	109.0"	2769 mm	109.0"
Overall Length (with P Blade)	4321 mm	170.1"	4294 mm	169.1"	4321 mm	170.1"	4321 mm	170.1"
(without Blade)	3199 mm	125.9"	3265 mm	128.5"	3199 mm	125.9"	3265 mm	128.5"
Width (w/o Trunnion and Blade – Std. Shoe)	2110 mm	83.1"	2410 mm	94.9"	2110 mm	83.1"	2410 mm	94.9"
Ground Clearance	332 mm	13"	332 mm	13"	332 mm	13"	332 mm	13"
Blade Types and Widths:								
VPAT, Straight	2782 mm	109.5"	3220 mm	126.7"	2782 mm	109.5"	3220 mm	126.7"
VPAT, Angled 25°	2636 mm	103.8"	2940 mm	115.8"	2636 mm	103.8"	2940 mm	115.8"
Fuel Tank Refill Capacity	195 L	51.5 U.S. gal	195 L	51.5 U.S. gal	195 L	51.5 U.S. gal	195 L	51.5 U.S. gal
DEF Tank Refill Capacity	—		—		19 L	5 U.S. gal	19 L	5 U.S. gal

<sup>1</sup> Meets Tier 3/Stage IIIA/Japan 2006 (Tier 3) equivalent emission standards.

<sup>2</sup> Operating weight includes ROPS canopy, operator, lubricants, coolant, full fuel tank, hydraulic controls and fluids, back-up alarm, seat belts, lights, rigid drawbar, front pull device and standard service crankcase guard.

MODEL	D5R2 XL		D5R2 LGP		D5T XL	
Emission Standards	Tier 3/Stage IIIA/ Japan 2006 (Tier 3) equivalent		Tier 3/Stage IIIA/ Japan 2006 (Tier 3) equivalent		Tier 3/Stage IIIA/ Japan 2006 (Tier 3) equivalent	
Flywheel Power	112 kW	150 hp	112 kW	150 hp	112 kW	150 hp
Operating Weight:						
Power Shift Differential Steer	16 672 kg	36,755 lb	18 584 kg	40,971 lb	16 672 kg	36,755 lb
Engine Model	C7.1 ACERT		C7.1 ACERT		C7.1 ACERT	
Rated Engine RPM	2200		2200		2200	
No. of Cylinders	6		6		6	
Bore	105 mm	4.13"	105 mm	4.13"	105 mm	4.13"
Stroke	135 mm	5.3"	135 mm	5.3"	135 mm	5.3"
Displacement	7.01 L	427.8 in <sup>3</sup>	7.01 L	427.8 in <sup>3</sup>	7.01 L	427.8 in <sup>3</sup>
Track Rollers (Each Side)	7		8		7	
Width of Standard Track Shoe	610 mm	24"	840 mm	33.1"	610 mm	24"
Length of Track on Ground	2611 mm	103"	3113 mm	122.6"	2611 mm	103"
Ground Contact Area (w/Std. Shoe)	3.18 m <sup>2</sup>	4929 in <sup>2</sup>	5.23 m <sup>2</sup>	8107 in <sup>2</sup>	3.18 m <sup>2</sup>	4929 in <sup>2</sup>
Track Gauge	1890 mm	74.4"	2160 mm	85"	1890 mm	74.4"
GENERAL DIMENSIONS:						
Height (To Top of ROPS Cab/Canopy)	3086 mm	121.5"	3200 mm	126.0"	3086 mm	121.5"
Length of Basic Tractor (w/o Blade)	3480 mm	137.0"	4017 mm	158.1"	3480 mm	137.0"
with following attachments, add:						
SU Blade	1546 mm	60.9"	—	—	1546 mm	60.9"
A Blade (when Straight)	1450 mm	57.1"	—	—	—	—
A Blade (when Angled 25°)	2303 mm	90.7"	—	—	—	—
VPAT Blade (when Straight)	1343 mm	52.9"	1249 mm	49.2"	1343 mm	52.9"
VPAT Blade (when Angled 25°)	1965 mm	77.4"	2004 mm	78.9"	1965 mm	77.4"
Rear Drawbar	192 mm	7.6"	148 mm	5.8"	192 mm	7.6"
Multi-Shank Ripper (tip at ground level)	1230 mm	48.4"	1190 mm	46.9"	1230 mm	48.4"
Width of Tractor:	2500 mm	98.4"	3000 mm	118"	2500 mm	98.4"
Over Trunnion	2640 mm	103.9"	3279 mm	129.1"	2640 mm	103.9"
Without Trunnion (standard shoe width)	2490 mm	98.0"	3000 mm	118.1"	2490 mm	98.0"
Ground Clearance	394 mm	15.5"	507 mm	20.0"	394 mm	15.5"
Blade Types and Widths:						
SU Blade	3154 mm	124.2"	—	—	3154 mm	124.2"
A Blade	4165 mm	164.0"	—	—	—	—
VPAT Blade — XL	3272 mm	128.8"	—	—	3272 mm	128.8"
VPAT Blade — LGP	—	—	4080 mm	160.6"	—	—
Fuel Tank Refill Capacity	299 L	79.3 U.S. gal	299 L	79.3 U.S. gal	299 L	79.3 U.S. gal

MODEL	D6K2 XL		D6K2 LGP		D6K2 XL		D6K2 LGP	
Emission Standards	Tier 3/Stage IIIA/ Japan 2006 (Tier 3) equivalent		Tier 3/Stage IIIA/ Japan 2006 (Tier 3) equivalent		Tier 4 Final/Stage IV/ Japan 2014 (Tier 4 Final)		Tier 4 Final/Stage IV/ Japan 2014 (Tier 4 Final)	
Flywheel Power:								
Hydrostatic	97 kW	130 hp	97 kW	130 hp	97 kW	130 hp	97 kW	130 hp
Operating Weight:								
Hydrostatic	13 311 kg	29,346 lb	13 948 kg	30,750 lb	13 271 kg	29,258 lb	13 909 kg	30,664 lb
Engine Model	C7.1 ACERT		C7.1 ACERT		C4.4 ACERT		C4.4 ACERT	
Rated Engine RPM	2200		2200		2200		2200	
No. of Cylinders	6		6		4		4	
Bore	105 mm	4.13"	105 mm	4.13"	105 mm	4.13"	105 mm	4.13"
Stroke	135 mm	5.31"	135 mm	5.31"	127 mm	5.0"	127 mm	5.0"
Displacement	7.01 L	428.8 in <sup>3</sup>	7.01 L	428.8 in <sup>3</sup>	4.4 L	269 in <sup>3</sup>	4.4 L	269 in <sup>3</sup>
Track Rollers (Each Side)	7 or 8		7 or 8		8		8	
Width of Standard Track Shoe	560 mm	22"	760 mm	30"	560 mm	22"	760 mm	30"
Length of Track on Ground	2645 mm	104"	2645 mm	104"	2645 mm	104"	2645 mm	104"
Ground Contact Area (w/Std. Shoe)	3.0 m <sup>2</sup>	4650 in <sup>2</sup>	4.0 m <sup>2</sup>	6200 in <sup>2</sup>	3.0 m <sup>2</sup>	4650 in <sup>2</sup>	4.0 m <sup>2</sup>	6200 in <sup>2</sup>
Track Gauge	1770 mm	70"	2000 mm	79"	1770 mm	70"	2000 mm	79"
GENERAL DIMENSIONS:								
Height (To Top of ROPS Cab)	2958 mm	116.5"	2958 mm	116.5"	2958 mm	116.5"	2958 mm	116.5"
Overall Length								
(with VPAT Blade)**	5008 mm	197"	5008 mm	197"	5008 mm	197"	5008 mm	197"
without Blade**	4588 mm	181"	4588 mm	181"	4588 mm	181"	4588 mm	181"
Width (w/o Trunnion and Blade — Std. Shoe)*	2330 mm	91.7"	2760 mm	108.7"	2330 mm	91.7"	2760 mm	108.7"
Ground Clearance	360 mm	14.2"	360 mm	14.2"	360 mm	14.2"	360 mm	14.2"
Blade Types and Widths:								
VPAT, straight	3196 mm	125.8"	3682 mm	145.0"	3196 mm	125.8"	3682 mm	145.0"
VPAT, angled	2896 mm	114.0"	3337 mm	131.4"	2896 mm	114.0"	3337 mm	131.4"
Fuel Tank Refill Capacity	295 L	77.9 U.S. gal	295 L	77.9 U.S. gal	260 L	69 U.S. gal	260 L	69 U.S. gal
DEF Tank Refill Capacity	—		—		19 L	5 U.S. gal	19 L	5 U.S. gal

\*Width (w/o Trunnion — Std. Shoe) is also w/o VPAT Blade.

\*\*With drawbar.

<b>MODEL</b>	<b>D6N XL</b>		<b>D6N LGP</b>	
Emission Standards	<b>Tier 4 Final/Stage IV/ Japan 2014 (Tier 4 Final)</b>		<b>Tier 4 Final/Stage IV/ Japan 2014 (Tier 4 Final)</b>	
Flywheel Power:				
Power Shift	124 kW	<b>166 hp</b>	124 kW	<b>166 hp</b>
Operating Weight:				
Power Shift Differential Steer	16 757 kg	<b>36,943 lb</b>	18 346 kg	<b>40,446 lb</b>
Engine Model	<b>C7.1 ACERT</b>		<b>C7.1 ACERT</b>	
Rated Engine RPM	<b>2200</b>		<b>2200</b>	
No. of Cylinders	<b>6</b>		<b>6</b>	
Bore	105 mm	<b>4.13"</b>	105 mm	<b>4.13"</b>
Stroke	135 mm	<b>5.3"</b>	135 mm	<b>5.3"</b>
Displacement	7.1 L	<b>433 in<sup>3</sup></b>	7.1 L	<b>433 in<sup>3</sup></b>
Track Rollers (Each Side)	<b>7</b>		<b>8</b>	
Width of Standard Track Shoe	610 mm	<b>24"</b>	840 mm	<b>33"</b>
Length of Track on Ground	2605 mm	<b>102.6"</b>	3110 mm	<b>122.4"</b>
Ground Contact Area (w/Std. Shoe)	3.18 m <sup>2</sup>	<b>4929 in<sup>2</sup></b>	5.24 m <sup>2</sup>	<b>8122 in<sup>2</sup></b>
Track Gauge	1890 mm	<b>74.4"</b>	2160 mm	<b>85"</b>
GENERAL DIMENSIONS:				
Height (To Top of ROPS Canopy)	<b>NA**</b>		<b>NA**</b>	
Height (To Top of ROPS Cab)	3088 mm	<b>121.6"</b>	3202 mm	<b>126"</b>
Overall Length (with VPAT Blade)	5035 mm	<b>198.2"</b>	5401 mm	<b>212.6"</b>
without Blade	3735 mm	<b>147"</b>	4146 mm	<b>163.2"</b>
with SU Blade	5165 mm	<b>203.3"</b>	—	
Width (over Trunnion)	2630 mm	<b>103.5"</b>	—	
Width (w/o Trunnion — Std. Shoe)*	2500 mm	<b>98.4"</b>	3000 mm	<b>118"</b>
Ground Clearance	394 mm	<b>15.5"</b>	507 mm	<b>20"</b>
Blade Types and Widths:				
Semi-U	3154 mm	<b>124.2"</b>	—	
VPAT	3272 mm	<b>128.8"</b>	4080 mm	<b>160.6"</b>
Fuel Tank Refill Capacity	277 L	<b>73.2 U.S. gal</b>	277 L	<b>73.2 U.S. gal</b>
Diesel Exhaust Fluid Refill Capacity	19 L	<b>5 U.S. gal</b>	19 L	<b>5 U.S. gal</b>

\*Width (w/o Trunnion — Std. Shoe) is also w/o VPAT Blade.

\*\*Canopy not available.

MODEL	D6R2		D6R2 XL		D6R2 LGP	
Emission Standards	Tier 3/Stage IIIA/ Japan 2006 (Tier 3) equivalent <sup>1</sup>		Tier 3/Stage IIIA/ Japan 2006 (Tier 3) equivalent <sup>1</sup>		Tier 3/Stage IIIA/ Japan 2006 (Tier 3) equivalent <sup>1</sup>	
Flywheel Power:						
Stage II — ISO 9249/SAE J1349	133 kW	<b>179 hp</b>	148 kW	<b>198 hp</b>	148 kW	<b>198 hp</b>
Stage IIIA — ISO 9249/SAE J1349	147 kW	<b>196 hp</b>	153 kW	<b>206 hp</b>	153 kW	<b>206 hp</b>
Operating Weight: <sup>2</sup>						
Power Shift Differential Steer (SU Blade)	19 066 kg	<b>42,033 lb</b>	19 914 kg	<b>43,903 lb</b>	21 661 kg	<b>47,754 lb</b>
Engine Model	<b>C9 ACERT</b>		<b>C9 ACERT</b>		<b>C9 ACERT</b>	
Rated Engine RPM:						
Stage II	<b>2000</b>		<b>2000</b>		<b>2000</b>	
Stage IIIA	<b>1850</b>		<b>1850</b>		<b>1850</b>	
No. of Cylinders	<b>6</b>		<b>6</b>		<b>6</b>	
Bore	112 mm	<b>4.4"</b>	112 mm	<b>4.4"</b>	112 mm	<b>4.4"</b>
Stroke	149 mm	<b>5.9"</b>	149 mm	<b>5.9"</b>	149 mm	<b>5.9"</b>
Displacement	8.8 L	<b>537 in<sup>3</sup></b>	8.8 L	<b>537 in<sup>3</sup></b>	8.8 L	<b>537 in<sup>3</sup></b>
Track Rollers (Each Side)	<b>6</b>		<b>7</b>		<b>8</b>	
Width of Standard Track Shoe	560 mm	<b>22"</b>	560 mm	<b>22"</b>	915 mm	<b>36"</b>
Length of Track on Ground	2664 mm	<b>104.9"</b>	2871 mm	<b>113"</b>	3275 mm	<b>128.9"</b>
Ground Contact Area (w/Std. Shoe)	2.98 m <sup>2</sup>	<b>4625 in<sup>2</sup></b>	3.22 m <sup>2</sup>	<b>4984 in<sup>2</sup></b>	5.99 m <sup>2</sup>	<b>9290 in<sup>2</sup></b>
Track Gauge	1880 mm	<b>74"</b>	1880 mm	<b>74"</b>	2286 mm	<b>90.0"</b>
GENERAL DIMENSIONS:						
Height (To Top of ROPS Cab/Canopy)	3216 mm	<b>126.6"</b>	3216 mm	<b>126.6"</b>	3266 mm	<b>128.6"</b>
Height (To Exhaust Stack)	3115 mm	<b>122.6"</b>	3115 mm	<b>122.6"</b>	3165 mm	<b>124.6"</b>
Length of Basic Tractor (w/o Blade)	3860 mm	<b>152.0"</b>	3860 mm	<b>152.0"</b>	4247 mm	<b>167.2"</b>
with following attachments, add:						
S Blade	1043 mm	<b>41.1"</b>	—		1218 mm	<b>48.0"</b>
SU Blade	1235 mm	<b>48.6"</b>	1472 mm	<b>58.0"</b>	—	
Angle Blade (when Straight)	1147 mm	<b>45.2"</b>	1349 mm	<b>53.1"</b>	—	
Angle Blade (when Angled 25°)	1983 mm	<b>78.1"</b>	2185 mm	<b>86.0"</b>	—	
Rear Drawbar	366 mm	<b>14.4"</b>	366 mm	<b>14.4"</b>	251 mm	<b>9.9"</b>
Multi-Shank Ripper (tip at ground level)	1403 mm	<b>55.2"</b>	1403 mm	<b>55.2"</b>	—	
Width of Tractor:						
Over Trunnion	2640 mm	<b>103.9"</b>	2640 mm	<b>103.9"</b>	3491 mm	<b>137.4"</b>
Without Trunnion (standard shoe width)	2440 mm	<b>96.1"</b>	2440 mm	<b>96.1"</b>	3201 mm	<b>126.0"</b>
Ground Clearance	372 mm	<b>14.6"</b>	372 mm	<b>14.6"</b>	422 mm	<b>16.6"</b>
Blade Types and Widths:						
S Blade	3360 mm	<b>132.3"</b>	—		4063 mm	<b>160.0"</b>
SU Blade	3260 mm	<b>128.3"</b>	3260 mm	<b>128.3"</b>	—	
Angle Blade	4166 mm	<b>164.0"</b>	4166 mm	<b>164.0"</b>	—	
Fuel Tank Refill Capacity	424 L	<b>112 U.S. gal</b>	424 L	<b>112 U.S. gal</b>	424 L	<b>112 U.S. gal</b>

<sup>1</sup> Meets Tier 2/Stage II/ Japan 2001 (Tier 2) equivalent OR Tier 3/Stage IIIA/ Japan 2006 (Tier 3) equivalent emission standards.

<sup>2</sup> Operating weight includes ROPS canopy, operator lubricants, coolants, full fuel tank, hydraulic controls and fluid, SU blades, horn, backup alarm, retrieval hitch and front pull hook.



MODEL	D6T		D6T XL	
	Tier 3/Stage IIIA/ Japan 2006 (Tier 3) equivalent		Tier 3/Stage IIIA/ Japan 2006 (Tier 3) equivalent	
Emission Standards				
Flywheel Power	149 kW	200 hp	149 kW	200 hp
Operating Weight: <sup>1</sup>				
Power Shift Differential Steer				
SU Blade	20 580 kg	45,370 lb	21 600 kg	47,620 lb
Engine Model	C9 ACERT		C9 ACERT	
Rated Engine RPM: Power Shift	1850		1850	
No. of Cylinders	6		6	
Bore	112 mm	4.4"	112 mm	4.4"
Stroke	149 mm	5.9"	149 mm	5.9"
Displacement	8.8 L	537 in <sup>3</sup>	8.8 L	537 in <sup>3</sup>
Track Rollers (Each Side)	6		7	
Width of Standard Track Shoe	560 mm	22"	560 mm	22"
Length of Track on Ground	2.61 m	8'7"	2.81 m	9'3"
Ground Contact Area (w/Std. Shoe)	2.92 m <sup>2</sup>	4531 in <sup>2</sup>	3.15 m <sup>2</sup>	4878 in <sup>2</sup>
Track Gauge	1.88 m	74"	1.88 m	74"
GENERAL DIMENSIONS:				
Height <sup>2</sup> (Stripped Top) <sup>3</sup>	2.40 m	7'11"	2.40 m	7'11"
Height <sup>2</sup> (To Top of ROPS Canopy)	3.11 m	10'2"	3.11 m	10'2"
Height <sup>2</sup> (To Top of ROPS Cab)	3.11 m	10'2"	3.11 m	10'2"
Overall Length (without Blade)	3.85 m	12'7"	3.85 m	12'7"
with SU Blade	5.08 m	16'8"	5.33 m	17'6"
with Angle Blade	5.00 m	16'5"	5.21 m	17'1"
Width (over Trunnion)	2.64 m	8'8"	2.64 m	8'8"
Width (w/o Trunnion — Std. Track)	2.44 m	8'0"	2.44 m	8'0"
Ground Clearance <sup>2</sup>	384 mm	1'3"	384 mm	1'3"
Blade Types and Widths:				
Angle Straight	4.16 m	13'8"	4.16 m	13'8"
Full 25° Angle	3.77 m	12'5"	3.77 m	12'5"
Semi-U	3.26 m	10'8"	3.26 m	10'8"
Fuel Tank Refill Capacity	425 L	112 U.S. gal	425 L	112 U.S. gal

<sup>1</sup> Operating weight includes cab, operator, lubricants, coolant, full fuel tank, standard track, hydraulic controls and fluid, SU blade, drawbar and counterweight.

<sup>2</sup> Dimensions measured from ground line. Add grouser height for total dimension on hard surfaces.

<sup>3</sup> Height (Stripped Top) — without ROPS canopy, exhaust, seat back or other easily removed encumbrances.

### Track-Type Tractor Sustainability

Well matched engine and power train systems enhance productivity and fuel efficiency.

MODEL	D6T XL		D6T XW		D6T LGP	
Emission Standards	Tier 4 Final/Stage IV/ Japan 2014 (Tier 4 Final)		Tier 4 Final/Stage IV/ Japan 2014 (Tier 4 Final)		Tier 4 Final/Stage IV/ Japan 2014 (Tier 4 Final)	
Flywheel Power	151 kW	202 hp	151 kW	202 hp	151 kW	202 hp
Operating Weight: <sup>1</sup>						
Power Shift Differential Steer	20 985 kg	46,263 lb	21 788 kg	48,034 lb	22 902 kg	50,490 lb
VPAT	23 663 kg	52,167 lb	24 118 kg	53,170 lb	24 336 kg	53,651 lb
Engine Model	C9.3 ACERT		C9.3 ACERT		C9.3 ACERT	
Advertised Engine RPM	2000		2000		2000	
No. of Cylinders	6		6		6	
Bore	115 mm	4.5"	115 mm	4.5"	115 mm	4.5"
Stroke	149 mm	5.9"	149 mm	5.9"	149 mm	5.9"
Displacement	9.3 L	567 in <sup>3</sup>	9.3 L	567 in <sup>3</sup>	9.3 L	567 in <sup>3</sup>
Track Rollers (Each Side)	7		7		8	
VPAT	7		8		8	
Width of Standard Track Shoe	560 mm	22"	760 mm	30"	915 mm	36"
VPAT	560 mm	22"	710 mm	28"	785 mm	31"
Length of Track on Ground	2.84 m	9'5"	2.84 m	9'5"	3.25 m	10'9"
VPAT	2.84 m	9'5"	3.25 m	10'9"	3.25 m	10'9"
Ground Contact Area (w/Std. Shoe)	3.54 m <sup>2</sup>	5489 in <sup>2</sup>	4.81 m <sup>2</sup>	7449 in <sup>2</sup>	6.53 m <sup>2</sup>	10,122 in <sup>2</sup>
VPAT	3.54 m <sup>2</sup>	5489 in <sup>2</sup>	5.10 m <sup>2</sup>	7909 in <sup>2</sup>	5.60 m <sup>2</sup>	8684 in <sup>2</sup>
Track Gauge	1.88 m	74"	2.03 m	80"	2.29 m	90"
VPAT	2.13 m	84"	2.29 m	90"	2.29 m	90"
GENERAL DIMENSIONS:						
Height <sup>2</sup> (Stripped Top <sup>3</sup> )	2.46 m	8'1"	2.46 m	8'1"	2.51 m	8'3"
VPAT	2.46 m	8'1"	2.51 m	8'3"	2.51 m	8'3"
Height <sup>2</sup> (To Top of ROPS Canopy)	3.11 m	10'2"	3.11 m	10'2"	3.16 m	10'4"
VPAT	3.11 m	10'2"	3.16 m	10'4"	3.16 m	10'4"
Height <sup>2</sup> (To Top of ROPS Cab)	3.15 m	10'4"	3.15 m	10'4"	3.20 m	10'6"
VPAT	3.15 m	10'4"	3.20 m	10'6"	3.20 m	10'6"
Overall Length (without Blade)	3.89 m	12'9"	3.89 m	12'9"	4.25 m	13'11"
VPAT	3.89 m	12'9"	4.25 m	13'11"	4.25 m	13'11"
with S Blade	—	—	—	—	5.50 m	18'1"
with SU Blade	5.33 m	17'6"	5.33 m	17'6"	—	—
with VPAT Blade	5.39 m	17'8"	5.53 m	18'2"	5.53 m	18'2"
with Angle Blade	5.21 m	17'1"	5.29 m	17'4"	5.81 m	19'1"
Width (over Trunnion)	2.69 m	8'10"	2.94 m	9'8"	3.48 m	11'5"
Width (w/o Trunnion — Std. Track)	2.59 m	8'6"	2.79 m	9'2"	3.20 m	10'6"
VPAT	2.72 m	8'11"	3.00 m	9'10"	3.14 m	10'4"
Ground Clearance <sup>2</sup>	372 mm	1'3"	372 mm	1'3"	406 mm	1'4"
VPAT	372 mm	1'3"	406 mm	1'4"	406 mm	1'4"
Blade Types and Widths:						
Straight	—	—	—	—	4.06 m	13'4"
Angle Straight	4.16 m	13'8"	4.52 m	14'10"	5.07 m	16'8"
Full 25° Angle	3.77 m	12'5"	4.11 m	13'6"	4.63 m	15'2"
Semi-U	3.26 m	12'8"	3.56 m	11'8"	—	—
VPAT						
Straight	3.88 m	12'9"	4.16 m	13'8"	4.16 m	13'8"
Full 24° Angle	3.54 m	11'7"	3.79 m	12'5"	3.79 m	12'5"
Fuel Tank Refill Capacity	411 L	109 U.S. gal	411 L	109 U.S. gal	411 L	109 U.S. gal
DEF Tank Refill Capacity	17.1 L	4.5 U.S. gal	17.1 L	4.5 U.S. gal	17.1 L	4.5 U.S. gal

<sup>1</sup> Operating weight includes cab, operator, lubricants, coolant, full fuel tank, standard track, hydraulic controls and fluid, SU blade and drawbar.

<sup>2</sup> Dimensions measured from ground line. Add grouser height for total dimension on hard surfaces.

<sup>3</sup> Height (Stripped Top) — without ROPS canopy, exhaust, seat back or other easily removed encumbrances.

MODEL	D7E		D7E LGP	
Emission Standards	Tier 4 Final/Stage IV/ Japan 2014 (Tier 4 Final)		Tier 4 Final/Stage IV/ Japan 2014 (Tier 4 Final)	
Advertised Flywheel Power	178 kW	238 hp	178 kW	238 hp
Operating Weight: <sup>1</sup>				
Electric Drive Differential Steer	26 055 kg	57,441 lb	28 525 kg	62,886 lb
Engine Model	C9.3 ACERT		C9.3 ACERT	
Advertised Engine RPM	1700		1700	
No. of Cylinders	6		6	
Bore	115 mm	4.5"	115 mm	4.5"
Stroke	149 mm	5.9"	149 mm	5.9"
Displacement	9.3 L	567 in <sup>3</sup>	9.3 L	567 in <sup>3</sup>
Track Rollers (Each Side)	7		8	
Width of Standard Track Shoe	610 mm	24"	915 mm	36"
Length of Track on Ground	3.02 m	9'11"	3.45 m	11'4"
Ground Contact Area (w/Std. Shoe)	3.68 m <sup>2</sup>	5698 in <sup>2</sup>	6.31 m <sup>2</sup>	9792 in <sup>2</sup>
Track Gauge	1.98 m	6'6"	2.29 m	7'6"
GENERAL DIMENSIONS:				
Height <sup>2</sup> (To Top of ROPS Cab)	3.32 m	10'11"	3.32 m	10'11"
Overall Length (without Blade)	4.88 m	16'0"	4.88 m	16'0"
with S Blade	5.86 m	19'3"	5.56 m	18'3"
with SU Blade	6.07 m	19'11"	—	—
Width (over Trunnion)	2.88 m	9'5"	3.42 m	11'3"
Width (w/o Trunnion — Std. Shoe)	2.59 m	8'6"	3.2 m	10'6"
Ground Clearance	472 mm	18.6"	472 mm	18.6"
Blade Types and Widths:				
Straight	3.9 m	12'10"	4.54 m	14'11"
Angle Straight	4.5 m	14'9"	—	—
Full 25° Angle	4.12 m	13'6"	—	—
Universal	3.99 m	13'1"	—	—
Semi-U	3.71 m	12'2"	—	—
Fuel Tank Refill Capacity	430 L	114 U.S. gal	430 L	114 U.S. gal
DEF Tank Refill Capacity	175 L	4.6 U.S. gal	175 L	4.6 U.S. gal

<sup>1</sup> Operating weight includes cab, operator, lubricants, coolant, full fuel tank, standard track, hydraulic controls and fluid, SU blade and drawbar.

<sup>2</sup> Dimensions measured from ground line. Add grouser height for total dimension on hard surfaces.

### Cat D7E — Resourceful in every way

- The D7E is designed to maximize efficiency and productivity while conserving natural resources.
- Burns 10–30% less fuel per hour than previous models. Less fuel burned means reduced emissions.
- The D7E earned a 2009 Clean Air Excellence Award from the U.S. Environmental Protection Agency.
- More efficient – 25% more material moved per liter/gallon of fuel.
- Fewer parts and longer component life, less fuel and fluids, means less to replace and less to dispose.
- Major structures and components are built to be rebuilt, reducing waste and replacement costs.

MODEL	D7R		D7R XR		D7R LGP	
Emission Standards	Tier 2/Stage II/ Japan 2001 (Tier 2) equivalent <sup>1</sup>		Tier 2/Stage II/ Japan 2001 (Tier 2) equivalent <sup>1</sup>		Tier 2/Stage II/ Japan 2001 (Tier 2) equivalent <sup>1</sup>	
Flywheel Power	179 kW	240 hp	179 kW	240 hp	179 kW	240 hp
Operating Weight: <sup>2</sup>						
Power Shift Differential Steer	25 455 kg	56,129 lb	27 002 kg	59,540 lb	27 626 kg	60,916 lb
Engine Model	C9 ACERT		C9 ACERT		C9 ACERT	
Rated Engine RPM: Power Shift	2100		2100		2100	
No. of Cylinders	6		6		6	
Bore	112 mm	4.4"	112 mm	4.4"	112 mm	4.4"
Stroke	149 mm	5.9"	149 mm	5.9"	149 mm	5.9"
Displacement	8.8 L	537 in <sup>3</sup>	8.8 L	537 in <sup>3</sup>	8.8 L	537 in <sup>3</sup>
Track Rollers (Each Side)	7		8		8	
Width of Standard Track Shoe	560 mm	22"	560 mm	22"	914 mm	36"
Length of Track on Ground	2.87 m	9'5"	3.05 m	10'0"	3.16 m	10'5"
Ground Contact Area (w/Std. Shoe)	3.22 m <sup>2</sup>	4991 in <sup>2</sup>	3.42 m <sup>2</sup>	5295 in <sup>2</sup>	5.78 m <sup>2</sup>	8960 in <sup>2</sup>
Track Gauge	1980 mm	6'6"	1980 mm	6'6"	2235 mm	7'4"
GENERAL DIMENSIONS:						
Height <sup>3</sup> (Stripped Top) <sup>4</sup>	2.58 m	8'6"	2.58 m	8'6"	2.7 m	8'10"
Height <sup>3</sup> (To Top of ROPS Canopy)	3.29 m	10'9"	3.29 m	10'9"	3.37 m	11'1"
Height <sup>3</sup> (To Top of ROPS Cab)	3.28 m	10'9"	3.28 m	10'9"	3.36 m	11'0"
Overall Length (without Blade)	4.73 m	15'6"	4.73 m	15'6"	4.73 m	15'6"
with following attachments, add:						
with S Blade	—	—	—	—	1071 mm	42.2"
with SU Blade	1301 mm	51.2"	1301 mm	51.2"	—	—
with A Blade (Straight)	1372 mm	54.0"	1372 mm	54.0"	—	—
Rear Drawbar	1188 mm	46.7"	1188 mm	46.7"	1188 mm	46.7"
Multi-Shank Ripper (tip at ground level)	2442 mm	96.1"	2442 mm	96.1"	2442 mm	96.1"
Width (over Trunnion)	2.88 m	9'5"	2.88 m	9'5"	3.37 m	11'1"
Width (w/o Trunnion — Std. Shoe)	2.54 m	8'4"	2.54 m	8'4"	3.15 m	10'4"
Ground Clearance	415 mm	1'4"	415 mm	1'4"	495 mm	1'7"
Blade Types and Widths:						
Straight Blade	—	—	—	—	4545 mm	178.9"
Semi-U Blade	3.69 m	12'2"	3.69 m	12'2"	—	—
Angle Blade	4496 mm	177.0"	4496 mm	177.0"	—	—
Fuel Tank Refill Capacity	481 L	127 U.S. gal	481 L	127 U.S. gal	481 L	127 U.S. gal

<sup>1</sup> Meets Tier 2/Stage II/Japan 2001 (Tier 2) equivalent OR Tier 3/Stage IIIA/Japan 2006 (Tier 3) equivalent emission standards.

<sup>2</sup> Operating weight includes cab, operator, lubricants, coolant, full fuel tank, standard track, hydraulic controls and fluid, SU blade, drawbar and counterweight.

<sup>3</sup> Dimensions measured from ground line. Add grouser height for total dimension on hard surfaces.

<sup>4</sup> Height (Stripped Top) — without ROPS canopy, exhaust, seat back or other easily removed encumbrances.

## Track-Type Tractor Sustainability

Major structures and components are built to be rebuilt, reducing waste and replacement costs.

MODEL	D8R		D8R LGP	
	Tier 1/Stage I		Tier 1/Stage I	
Emission Standards				
Flywheel Power	226 kW	303 hp	226 kW	303 hp
Operating Weight: <sup>1</sup>				
Power Shift Differential Steer	37 920 kg	83,600 lb	35 176 kg	77,550 lb
Engine Model	3406C TA		3406C TA	
Rated Engine RPM	2100		2100	
No. of Cylinders	6		6	
Bore	137 mm	5.4"	137 mm	5.4"
Stroke	165 mm	6.5"	165 mm	6.5"
Displacement	14.6 L	893 in <sup>3</sup>	14.6 L	893 in <sup>3</sup>
Track Rollers (Each Side)	8		8	
Width of Standard Track Shoe	610 mm	24"	965 mm	38"
Length of Track on Ground	3.21 m	10'6"	3.26 m	10'8"
Ground Contact Area (w/Std. Shoe)	3.91 m <sup>2</sup>	6062 in <sup>2</sup>	6.3 m <sup>2</sup>	9746 in <sup>2</sup>
Track Gauge	2.08 m	6'10"	2.34 m	7'8"
GENERAL DIMENSIONS:				
Height <sup>2</sup> (Stripped Top) <sup>3</sup>	2.67 m	8'9"	2.67 m	8'9"
Height <sup>2</sup> (To Top of ROPS Canopy)	3.45 m	11'4"	3.51 m	11'6"
Height <sup>2</sup> (To Top of ROPS Cab)	3.42 m	11'3"	3.49 m	11'5"
Overall Length (with SU Blade) <sup>4</sup>	6.80 m	22'4"	6.80 m	22'4"
(without Blade)	4.96 m	16'3"	4.96 m	16'3"
Overall Length (without Blade)	—	—	—	—
with S Blade	—	—	—	—
Width (over Trunnion)	3.05 m	10'0"	3.38 m	11'1"
Width (w/o Trunnion — Std. Shoe)	2.70 m	8'8"	3.30 m	10'10"
Ground Clearance	613 mm	2'0"	606 mm	2'0"
Blade Types and Widths:				
Straight	—	—	—	—
Angle Straight	4.99 m	16'4"	—	—
Full 25° Angle	4.52 m	14'10"	—	—
Universal	4.26 m	14'0"	—	—
Semi-U	3.94 m	12'11"	4.40 m	14'5"
Fuel Tank Refill Capacity	625 L	165 U.S. gal	625 L	165 U.S. gal

<sup>1</sup> Operating weight includes cab, operator, lubricants, coolant, full fuel tank, standard track, hydraulic controls and fluid, SU blade, drawbar and counterweight. — D8R equipped with track guides, ROPS/FOPS cab, single shank ripper and SU blade.

<sup>2</sup> Dimensions measured from ground line. Add grouser height for total dimension on hard surfaces.

<sup>3</sup> Height (Stripped Top) — without ROPS canopy, exhaust, seat back or other easily removed encumbrances.

<sup>4</sup> Includes drawbar.

### Track-Type Tractor Sustainability

Cat tractors are designed for ease of serviceability, with features like ground-level service points and wide engine enclosure doors.

MODEL	D8T		D8T LGP		D8T		D8T LGP	
Emission Standards	Tier 4 Interim/ Stage IIIB		Tier 4 Interim/ Stage IIIB		Tier 4 Final/Stage IV/ Japan 2014 (Tier 4 Final)		Tier 4 Final/Stage IV/ Japan 2014 (Tier 4 Final)	
Flywheel Power	233 kW	<b>312 hp</b>	233 kW	<b>312 hp</b>	233 kW	<b>312 hp</b>	233 kW	<b>312 hp</b>
Operating Weight: <sup>1</sup>								
Power Shift Differential Steer	39 751 kg	<b>87,650 lb</b>	37 750 kg	<b>83,224 lb</b>	39 795 kg	<b>87,733 lb</b>	37 795 kg	<b>83,324 lb</b>
Engine Model	<b>C15 ACERT</b>		<b>C15 ACERT</b>		<b>C15 ACERT</b>		<b>C15 ACERT</b>	
Rated Engine RPM	<b>1900</b>		<b>1900</b>		<b>1900</b>		<b>1900</b>	
No. of Cylinders	<b>6</b>		<b>6</b>		<b>6</b>		<b>6</b>	
Bore	137 mm	<b>5.4"</b>	137 mm	<b>5.4"</b>	137 mm	<b>5.4"</b>	137 mm	<b>5.4"</b>
Stroke	172 mm	<b>6.75"</b>	172 mm	<b>6.75"</b>	172 mm	<b>6.75"</b>	172 mm	<b>6.75"</b>
Displacement	15.2 L	<b>928 in<sup>3</sup></b>	15.2 L	<b>928 in<sup>3</sup></b>	15.2 L	<b>928 in<sup>3</sup></b>	15.2 L	<b>928 in<sup>3</sup></b>
Track Rollers (Each Side)	<b>8</b>		<b>8</b>		<b>8</b>		<b>8</b>	
Width of Standard Track Shoe	610 mm	<b>24"</b>	965 mm	<b>38"</b>	610 mm	<b>24"</b>	965 mm	<b>38"</b>
Length of Track on Ground	3.21 m	<b>10'6"</b>	3.20 m	<b>10'6"</b>	3.21 m	<b>10'6"</b>	3.21 m	<b>10'6"</b>
Ground Contact Area (w/Std. Shoe)	3.91 m <sup>2</sup>	<b>6062 in<sup>2</sup></b>	6.19 m <sup>2</sup>	<b>9593 in<sup>2</sup></b>	3.91 m <sup>2</sup>	<b>6062 in<sup>2</sup></b>	6.19 m <sup>2</sup>	<b>9593 in<sup>2</sup></b>
Track Gauge	2.08 m	<b>6'10"</b>	2.34 m	<b>7'8"</b>	2.08 m	<b>6'10"</b>	2.34 m	<b>7'8"</b>
GENERAL DIMENSIONS:								
Height <sup>2</sup> (Stripped Top) <sup>3</sup>	2.67 m	<b>8'9"</b>	2.67 m	<b>8'9"</b>	—	—	—	—
Height <sup>2</sup> (To Top of ROPS Canopy)	3.46 m	<b>11'4"</b>	3.45 m	<b>11'4"</b>	—	—	—	—
Height <sup>2</sup> (To Top of ROPS Cab)	3.46 m	<b>11'4"</b>	3.46 m	<b>11'4"</b>	3.51 m	<b>11'6"</b>	3.51 m	<b>11'6"</b>
Overall Length (with SU Blade) <sup>4</sup>	6.09 m	<b>20'0"</b>	6.09 m	<b>20'0"</b>	6.09 m	<b>20'0"</b>	6.09 m	<b>20'0"</b>
(without Blade)	4.64 m	<b>15'3"</b>	4.98 m	<b>16'4"</b>	4.64 m	<b>15'3"</b>	4.98 m	<b>16'4"</b>
Width (over Trunnion)	3.06 m	<b>10'0"</b>	3.38 m	<b>11'1"</b>	3.06 m	<b>10'0"</b>	3.38 m	<b>11'1"</b>
Width (w/o Trunnion — Std. Shoe)	2.64 m	<b>8'8"</b>	3.30 m	<b>10'10"</b>	2.64 m	<b>8'8"</b>	3.30 m	<b>10'10"</b>
Ground Clearance	613 mm	<b>2'0"</b>	613 mm	<b>2'0"</b>	613 mm	<b>2'0"</b>	613 mm	<b>2'0"</b>
Blade Types and Widths:								
Angle Straight	4.99 m	<b>16'4"</b>	—	—	4.99 m	<b>16'4"</b>	—	—
Full 25° Angle	5.05 m	<b>16'7"</b>	—	—	5.05 m	<b>16'7"</b>	—	—
Universal	4.26 m	<b>14'0"</b>	—	—	4.26 m	<b>14'0"</b>	—	—
Semi-U	3.94 m	<b>12'11"</b>	4.53 m	<b>14'10"</b>	3.94 m	<b>12'11"</b>	4.53 m	<b>14'10"</b>
Fuel Tank Refill Capacity	627 L	<b>165 U.S. gal</b>	627 L	<b>165 U.S. gal</b>	627 L	<b>165 U.S. gal</b>	627 L	<b>165 U.S. gal</b>
DEF Tank Refill Capacity	—	—	—	—	24 L	<b>6.3 U.S. gal</b>	24 L	<b>6.3 U.S. gal</b>

<sup>1</sup> Operating weight includes ROPS/FOPS cab, operator, lubricants, coolant, full fuel tank, standard track, hydraulic controls and fluid, SU blade and ripper. LGP operating weight includes drawbar instead of ripper.

<sup>2</sup> Dimensions measured from ground line. Add grouser height for total dimension on hard surfaces.

<sup>3</sup> Height (Stripped Top) — without ROPS canopy, exhaust, seat back or other easily removed encumbrances.

<sup>4</sup> Includes drawbar.

## Track-Type Tractor Sustainability

Cat engines with ACERT Technology provide powerful reliability, while meeting the stringent emissions standards.

MODEL	D9R		D9T		D9T	
Emission Standards	—		Tier 3/Stage IIIA/ Japan 2006 (Tier 3) equivalent <sup>1</sup>		Tier 4 Final/Stage IV/ Japan 2014 (Tier 4 Final)	
Flywheel Power	302 kW	<b>405 hp</b>	306 kW	<b>410 hp</b>	325 kW	<b>436 hp</b>
Operating Weight: <sup>2</sup>	48 784 kg <b>107,548 lb</b>		—		—	
Power Shift Clutch Brake	—		47 872 kg <b>105,539 lb</b>		48 361 kg <b>106,618 lb</b>	
Power Shift Differential Steer	—		—		—	
Engine Model	<b>3408C SCAC</b>		<b>C18 ACERT</b>		<b>C18 ACERT</b>	
Rated Engine RPM	<b>1900</b>		<b>1833</b>		<b>1800</b>	
No. of Cylinders	<b>8</b>		<b>6</b>		<b>6</b>	
Bore	137 mm	<b>5.4"</b>	145 mm	<b>5.7"</b>	145 mm	<b>5.7"</b>
Stroke	152 mm	<b>6"</b>	183 mm	<b>7.2"</b>	183 mm	<b>7.2"</b>
Displacement	18 L	<b>1099 in<sup>3</sup></b>	18.1 L	<b>1106 in<sup>3</sup></b>	18.1 L	<b>1106 in<sup>3</sup></b>
Track Rollers (Each Side)	<b>8</b>		<b>8</b>		<b>8</b>	
Width of Standard Track Shoe	610 mm	<b>24"</b>	610 mm	<b>24"</b>	610 mm	<b>24"</b>
Length of Track on Ground	3.47 m	<b>11'5"</b>	3.47 m	<b>11'5"</b>	3.47 m	<b>11'5"</b>
Ground Contact Area (w/Std. Shoe)	4.24 m <sup>2</sup>	<b>6569 in<sup>2</sup></b>	4.24 m <sup>2</sup>	<b>6569 in<sup>2</sup></b>	4.24 m <sup>2</sup>	<b>6569 in<sup>2</sup></b>
Track Gauge	2.25 m	<b>7'5"</b>	2.25 m	<b>7'5"</b>	2.25 m	<b>7'5"</b>
GENERAL DIMENSIONS:						
Height <sup>3</sup> (Stripped Top) <sup>4</sup>	3.69 m	<b>12'1"</b>	3.69 m	<b>12'1"</b>	3.69 m	<b>12'1"</b>
Height <sup>3</sup> (To Top of ROPS Canopy)	4.00 m	<b>13'1"</b>	4.00 m	<b>13'1"</b>	4.00 m	<b>13'1"</b>
Height <sup>3</sup> (To Top of FOPS Cab)	3.82 m	<b>12'6"</b>	3.82 m	<b>12'6"</b>	3.82 m	<b>12'6"</b>
Overall Length (with SU Blade) <sup>5</sup>	6.88 m	<b>22'6"</b>	6.88 m	<b>22'6"</b>	6.88 m	<b>22'6"</b>
(without Blade)	5.18 m	<b>17'0"</b>	5.18 m	<b>17'0"</b>	5.18 m	<b>17'0"</b>
(with SU Blade and Ripper) <sup>5</sup>	8.23 m	<b>27'0"</b>	8.23 m	<b>27'0"</b>	8.23 m	<b>27'0"</b>
(without Blade and Ripper)	4.91 m	<b>16'1"</b>	4.91 m	<b>16'1"</b>	4.91 m	<b>16'1"</b>
Width (over Trunnion)	3.30 m	<b>10'8"</b>	3.30 m	<b>10'8"</b>	3.30 m	<b>10'8"</b>
Width (w/o Trunnion — Std. Shoe)	2.88 m	<b>9'5"</b>	2.88 m	<b>9'5"</b>	2.88 m	<b>9'5"</b>
Ground Clearance <sup>6</sup>	496 mm	<b>1'7"</b>	496 mm	<b>1'7"</b>	496 mm	<b>1'7"</b>
Blade Types and Widths:						
Universal	4.65 m	<b>15'3"</b>	4.65 m	<b>15'3"</b>	4.65 m	<b>15'3"</b>
Semi-U	4.31 m	<b>14'2"</b>	4.31 m	<b>14'2"</b>	4.31 m	<b>14'2"</b>
Fuel Tank Refill Capacity	818 L	<b>216 U.S. gal</b>	889 L	<b>235 U.S. gal</b>	821 L	<b>217 U.S. gal</b>
DEF Tank Refill Capacity	—		—		36 L	<b>9.5 U.S. gal</b>

<sup>1</sup> Product available to meet Tier 2/Stage II/Japan 2001 (Tier 2) equivalent OR Tier 3/Stage IIIA/Japan 2006 (Tier 3) equivalent emission standards.

<sup>2</sup> Operating weight includes ROPS canopy, operator, lubricants, coolant, full fuel tank, hydraulic controls and fluids, semi universal blade with tilt, back-up alarm, seat belts, lights, and single shank ripper.

— D9R equipped with track guides, ROPS/FOPS cab, single shank ripper and SU blade.

<sup>3</sup> Dimensions measured from ground line. Add grouser height for total dimension on hard surfaces.

<sup>4</sup> Height (Stripped Top) — without ROPS canopy, exhaust, seat back or other easily removed encumbrances.

<sup>5</sup> Includes drawbar.

<sup>6</sup> Per ISO 6746 — Must add grouser height for total dimension on hard surfaces.

MODEL	D10T2		D11T		D11T CD	
Emission Standards	Tier 4 Final/Stage IV/ Japan 2014 (Tier 4 Final) <sup>1</sup>		Tier 4 Final/Stage IV/ Japan 2014 (Tier 4 Final) <sup>1</sup>		Tier 4 Final/Stage IV/ Japan 2014 (Tier 4 Final) <sup>1</sup>	
Flywheel Power	447 kW	600 hp	634 kW	850 hp	634 kW	850 hp
Reverse Gears	538 kW	722 hp	—	—	—	—
Operating Weight: <sup>2</sup>						
Power Shift Clutch Brake	70 171 kg	154,700 lb	104 236 kg	229,800 lb	112 718 kg	248,500 lb
Engine Model	C27 ACERT		C32 ACERT		C32 ACERT	
Rated Engine RPM	1800		1800		1800	
No. of Cylinders	12		12		12	
Bore	137 mm	5.4"	145 mm	5.71"	145 mm	5.71"
Stroke	152 mm	6"	162 mm	6.38"	162 mm	6.38"
Displacement	27 L	1648 in <sup>3</sup>	32.1 L	1959 in <sup>3</sup>	32.1 L	1959 in <sup>3</sup>
Track Rollers (Each Side)	8		8		8	
Width of Standard Track Shoe	610 mm	24"	710 mm	28"	915 mm	36"
Length of Track on Ground (Idler to Idler)	3.88 m	12'9"	4.44 m	14'7"	4.44 m	14'7"
Ground Contact Area (w/Std. Shoe)	4.74 m <sup>2</sup>	7347 in <sup>2</sup>	6.31 m <sup>2</sup>	9781 in <sup>2</sup>	8.13 m <sup>2</sup>	12,605 in <sup>2</sup>
Track Gauge	2.55 m	8'4"	2.89 m	9'6"	2.89 m	9'6"
GENERAL DIMENSIONS:						
Height (Stripped Top) <sup>3</sup>	3.222 m	10'7"	3.64 m	11'11"	3.64 m	11'11"
Height (To Top of ROPS Canopy)	4.41 m	14'5"	4.70 m	15'5"	4.70 m	15'5"
Height (To Top of FOPS Cab)	4.10 m	13'5"	4.39 m	14'5"	4.39 m	14'5"
Overall Length:						
(with SU Blade and SS Ripper) <sup>4</sup>	9.16 m	30'1"	10.59 m	34'9"	10.70 m	35'1"
(without Blade and Ripper) <sup>5</sup>	5.32 m	17'5"	6.16 m	20'3"	6.16 m	20'3"
Width (over Trunnion)	3.74 m	12'3"	4.38 m	14'4"	4.38 m	14'4"
Width (w/o Trunnion — Std. Shoe)	3.30 m	10'10"	3.78 m	12'5"	3.81 m	12'6"
Ground Clearance <sup>6</sup>	632 mm	2'1"	675 mm	2'3"	675 mm	2'3"
Blade Types and Widths:						
CarryDozer	—	—	—	—	6.71 m	22'0"
Universal	5.26 m	17'3"	6.36 m	20'10"	—	—
Semi-U	4.94 m	16'3"	5.60 m	18'4"	—	—
Fuel Tank Refill Capacity	1204 L	314 U.S. gal	1609 L	425 U.S. gal	1609 L	425 U.S. gal
Fuel Tank Refill Capacity (Extra Capacity)	—	—	1987 L	505 U.S. gal	1987 L	505 U.S. gal

<sup>1</sup> Product available to meet Tier 2/Stage II/Japan 2001 (Tier 2) equivalent OR Tier 4 Final/Stage IV/Japan 2014 (Tier 4 Final) emission standards.

<sup>2</sup> Operating weight includes coolant, lubricants, full fuel tank, ROPS, FOPS cab, SU ABR bulldozer (D10T2) or U ABR bulldozer (D11T), dual tilt, single-shank ripper with pin-puller, fast fuel, standard ES shoes, and operator.

D11T CD has 11 Carrydozer and single-shank Carrydozer ripper.

<sup>3</sup> Height (Stripped Top) — without ROPS canopy, cab, exhaust, lift cylinders, seat back or other easily removed encumbrances.

<sup>4</sup> Overall length of D11T CD includes Straight (CarryDozer) Blade and SS Ripper.

<sup>5</sup> Overall length of machine from front tag link trunnion to rigid drawbar and excludes track grouser height.

<sup>6</sup> Per ISO 6746 — Must add grouser height for total dimension on hard surfaces.

All dimensions are approximate.



**D3K2 XL  
D3K2 LGP**

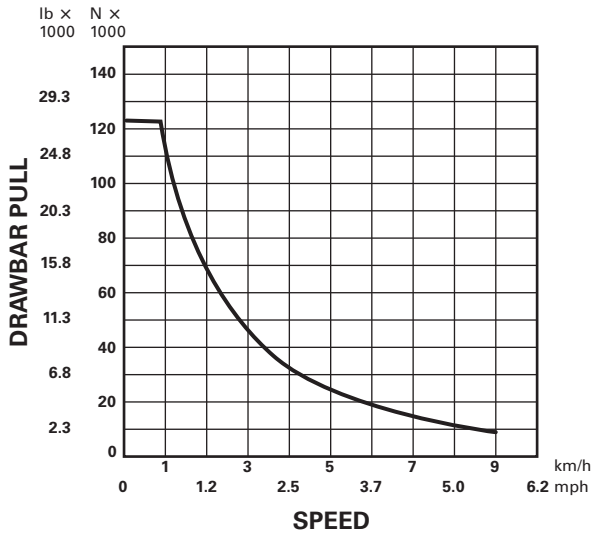

**NOTES:** Usable pull will depend upon weight and traction of equipped tractor.

Assumes sufficient machine weight for <5% track slip at POR pressure.

Assumes pumps and motors are broken in.

Assumes nominal engine power and valve settings.

Drawbar pull at track stall will be lower.

**D4K2 XL  
D4K2 LGP**

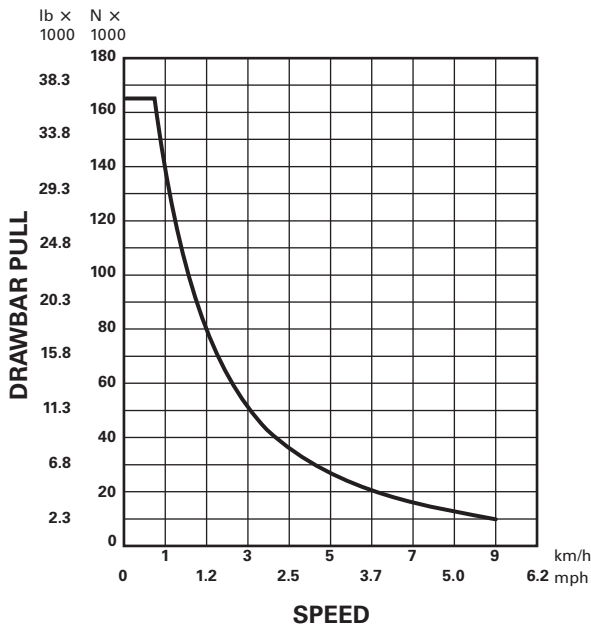

**D5K2 XL  
 D5K2 LGP**

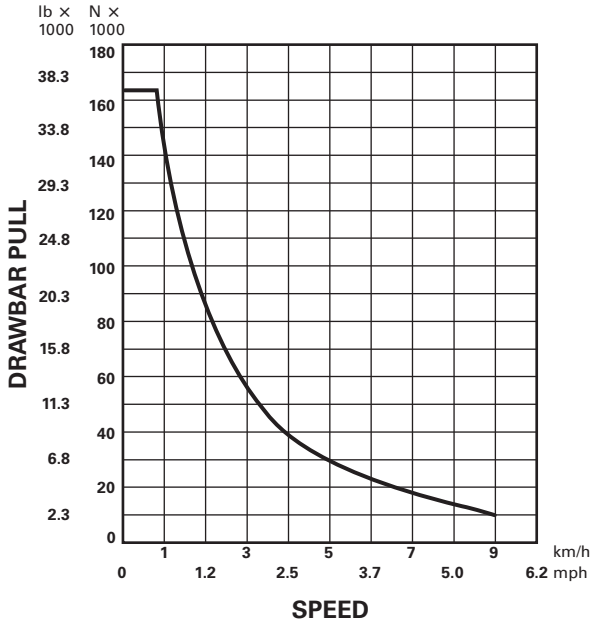

**NOTES:** Usable pull will depend upon weight and traction of equipped tractor.

Assumes sufficient machine weight for <5% track slip at POR pressure.

Assumes pumps and motors are broken in.

Assumes nominal engine power and valve settings.

Drawbar pull at track stall will be lower.

**D6K2 XL/D6K2 LGP**

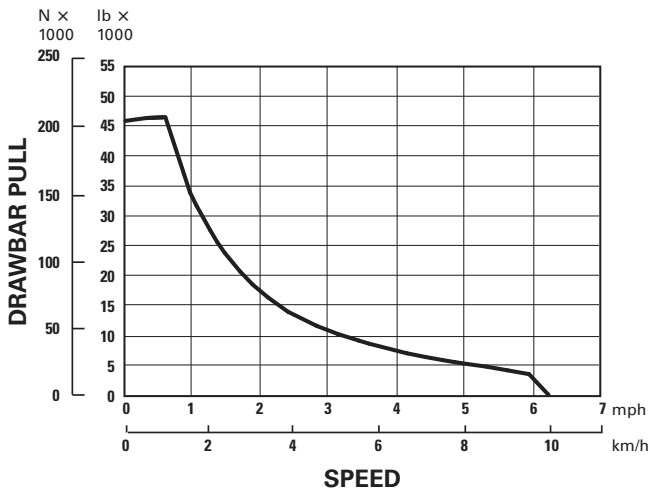

**D5R2 XL/LGP and D5T XL  
D6N XL/LGP**

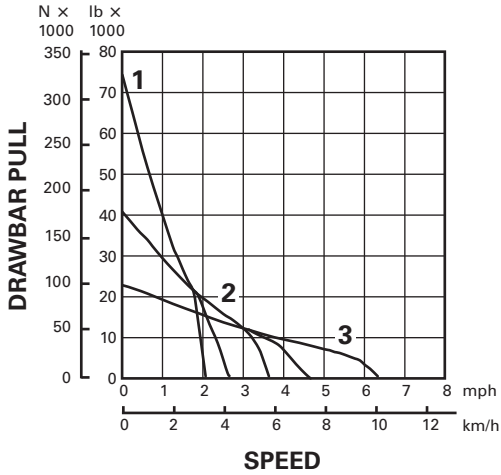

**D6N XL/LGP Tier 4 Final/Stage IV/  
Japan 2014 (Tier 4 Final)**

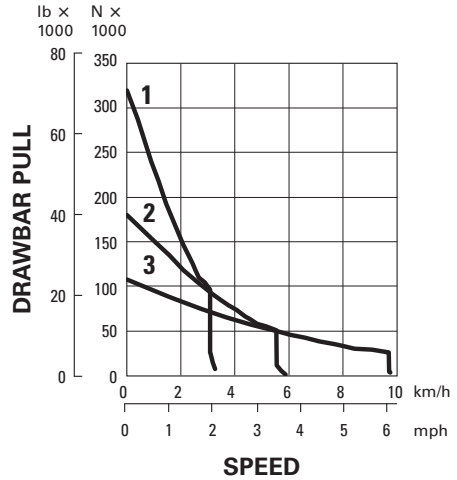

**D6R2 Tier 2/Stage II/  
Japan 2001 (Tier 2) equivalent**

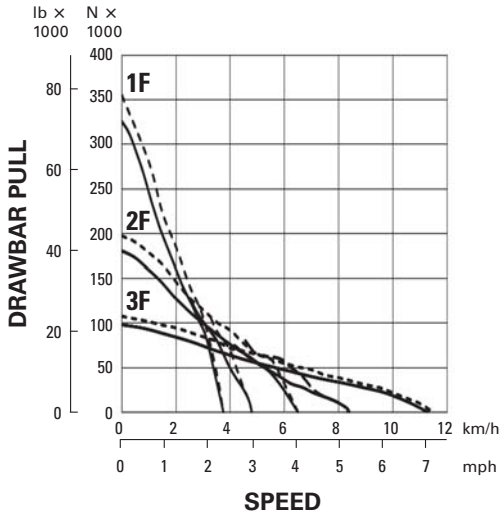

**D6R2 Tier 3/Stage IIIA/  
Japan 2006 (Tier 3) equivalent**

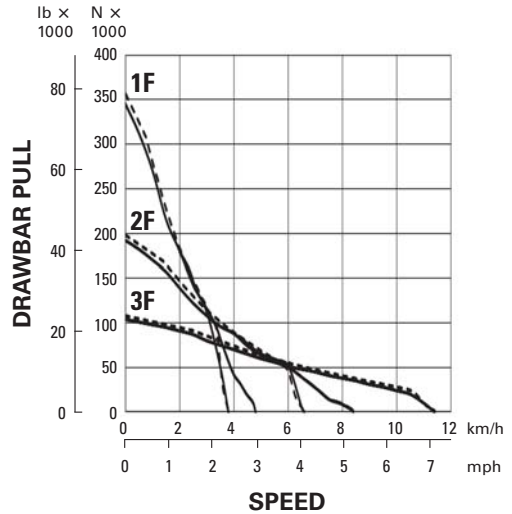

**KEY**

- STD
- - - - XL/LGP

**NOTE:** Usable pull will depend upon weight and traction of equipped tractor.

**D6T XL/XW/LGP**

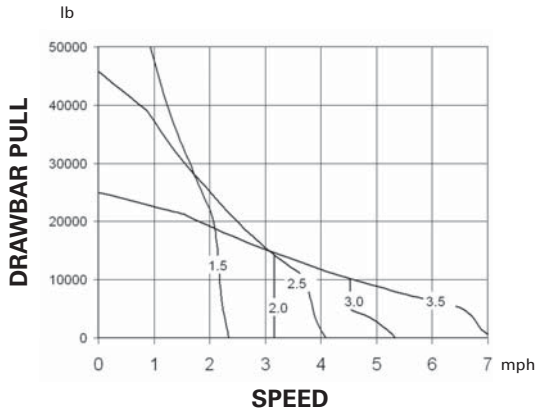

**D6T Tier 4 Final/Stage IV/  
Japan 2014 (Tier 4 Final)**

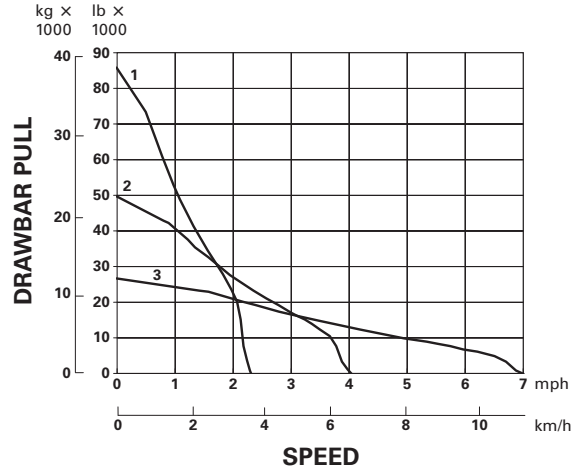

**D7E**

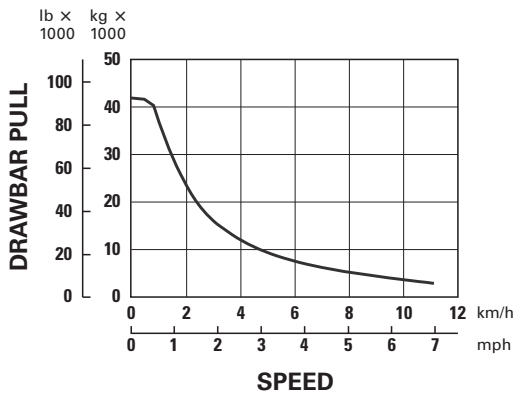

**D7R Standard/XR/LGP  
Differential Steer**

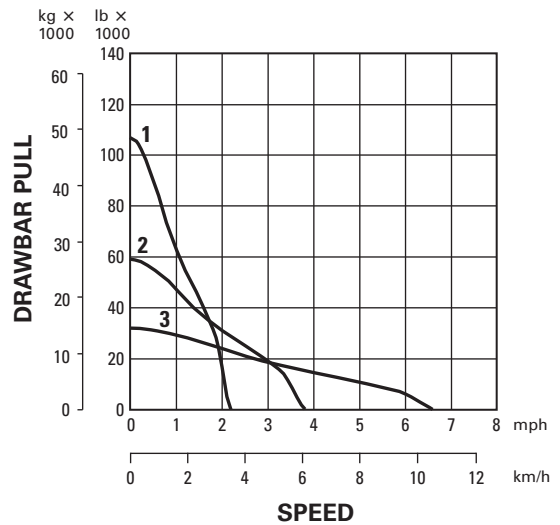

**KEY**

- 1 — 1st Gear
- 2 — 2nd Gear
- 3 — 3rd Gear

**NOTE:** Usable pull will depend upon weight and traction of equipped tractor.

**D8R  
D8R LGP**

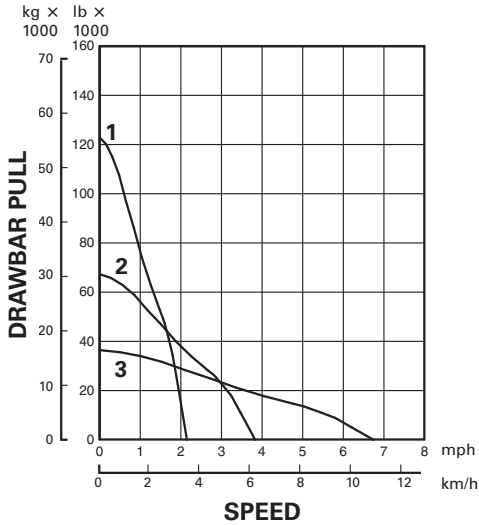

**D8T  
D8T LGP**

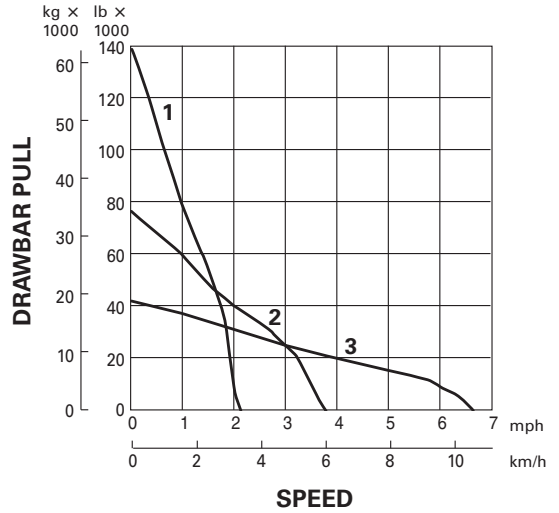

**D8T Tier 4 Final/Stage IV/  
Japan 2014 (Tier 4 Final)**

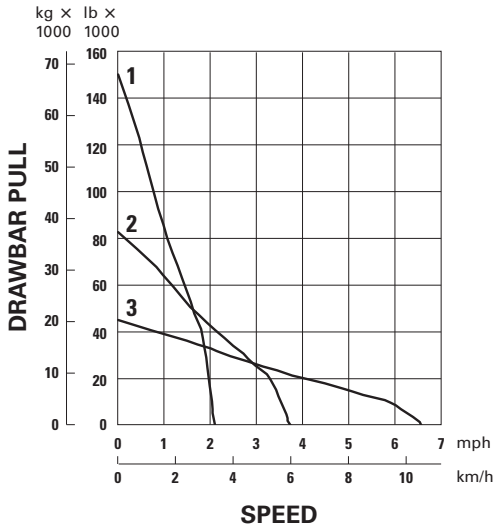

**D9R Power Shift with  
Steering Clutches and Brakes**

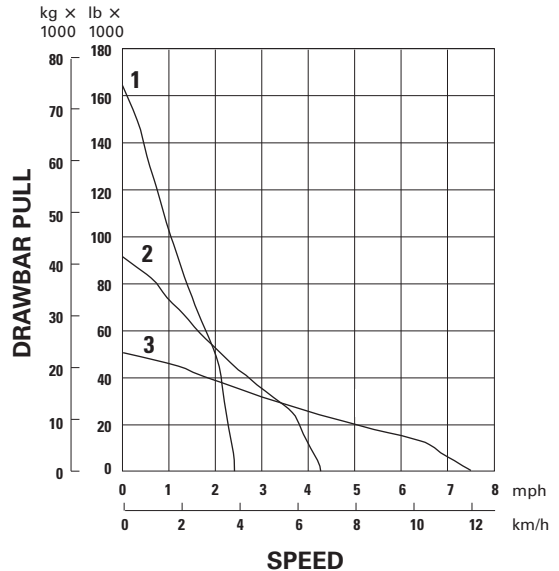

**KEY**

- 1 — 1st Gear
- 2 — 2nd Gear
- 3 — 3rd Gear

**NOTE:** Usable pull will depend upon weight and traction of equipped tractor.

**D9T Differential Steering**

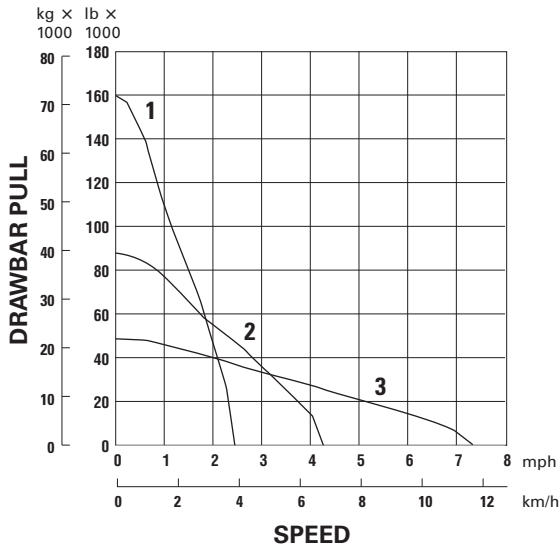

**D10T2**

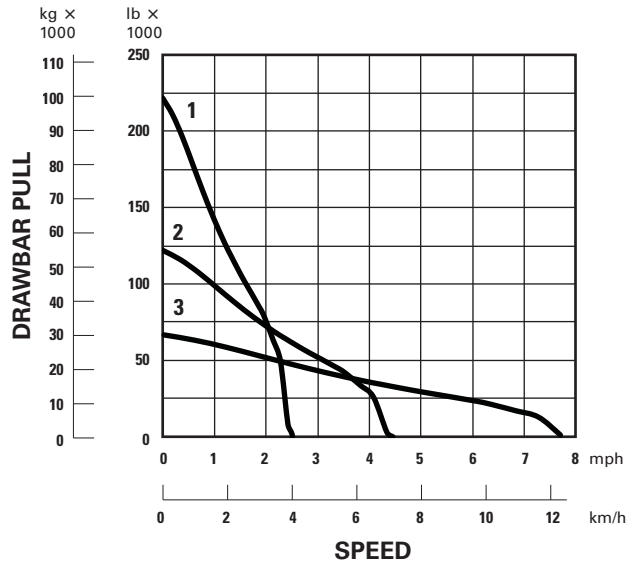

**D11T/D11T CD**

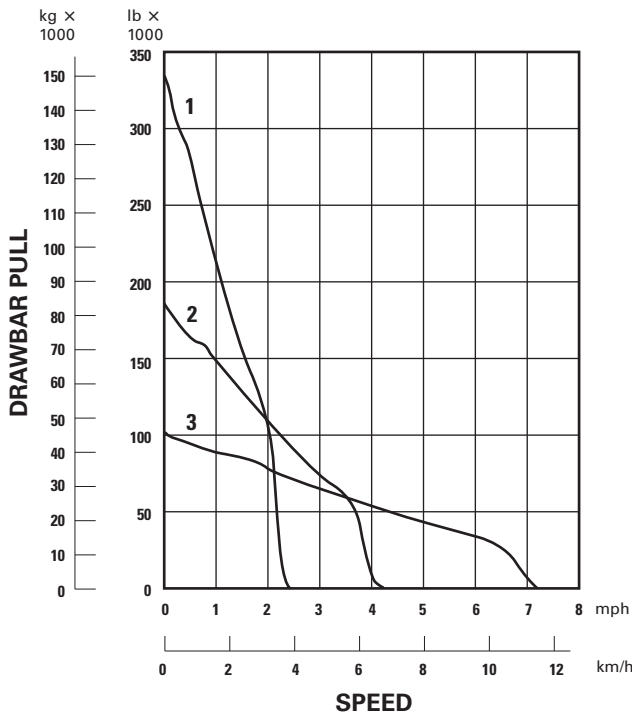

**KEY**

- 1 – 1st Gear
- 2 – 2nd Gear
- 3 – 3rd Gear

**NOTE:** Usable pull will depend upon weight and traction of equipped tractor. Tractors with suspended undercarriage can provide up to 15% more tractive effort than tractors with non-suspended undercarriage.

**TRAVEL SPEED**

POWER SHIFT MODEL	D3K2 <sup>1</sup> All Models		D3K2 All Models		D4K2 <sup>1</sup> All Models		D4K2 All Models		D5K2 <sup>1</sup> All Models		D5K2 All Models		D6K2 All Models	
	km/h	mph	km/h	mph	km/h	mph	km/h	mph	km/h	mph	km/h	mph	km/h	mph
HYDROSTATIC														
FORWARD	9.0	5.6	9.0	5.6	9.0	5.6	9.0	5.6	9.0	5.6	9.0	5.6	10.0	6.2
REVERSE	10.0	6.2	10.0	6.2	10.0	6.2	10.0	6.2	10.0	6.2	10.0	6.2	10.0	6.2

<sup>1</sup> Meets Tier 3/Stage IIIA/Japan 2006 (Tier 3) equivalent emission standards.

POWER SHIFT MODEL	D5R2 Powershift with AutoShift		D6R2 Powershift with AutoShift		D6T		D7E		D7E LGP		D7R	
	km/h	mph	km/h	mph	km/h	mph	km/h	mph	km/h	mph	km/h	mph
FORWARD												
1	3.3	2.1	3.8	2.4	3.8	2.3	—	—	—	—	3.52	2.19
1.5	4.2	2.6	4.8	3.0	—	—	—	—	—	—	—	—
2	5.8	3.6	6.5	4.1	6.5	4.0	—	—	—	—	6.10	3.79
2.5	7.3	4.5	8.4	5.2	—	—	—	—	—	—	—	—
3	10.1	6.3	11.5	7.1	11.3	7.0	—	—	—	—	10.54	6.55
REVERSE												
1	4.2	2.6	4.8	3.0	4.7	2.9	—	—	—	—	4.54	2.82
1.5	5.2	3.2	6.2	3.9	—	—	—	—	—	—	—	—
2	7.3	4.5	8.4	5.2	8.3	5.1	—	—	—	—	7.85	4.88
2.5	7.3	4.5	8.4	5.2	—	—	—	—	—	—	—	—
3	12.5	7.8	14.5	9.1	14.6	9.0	—	—	—	—	13.58	8.44
ELECTRIC												
FORWARD	—	—	—	—	—	—	11.3	7.0	11.3	7.0	—	—
REVERSE	—	—	—	—	—	—	11.3	7.0	11.3	7.0	—	—

GEAR	D6N* Powershift with AutoShift — Sound Suppressed			
	D6N* Powershift with AutoShift		D6N* Powershift with AutoShift — Sound Suppressed	
FORWARD	km/h	mph	km/h	mph
0.5	2.5	1.6	2.4	1.5
0.7	2.8	1.7	2.7	1.6
1.0	3.3	2.1	3.0	1.9
1.5	4.4	2.7	4.4	2.7
1.7	4.9	3.0	4.9	3.0
2.0	5.8	3.6	5.8	3.6
2.5	7.5	4.7	7.5	4.7
2.7	8.3	5.2	8.3	5.2
3.0	9.8	6.1	9.8	6.1
REVERSE				
0.5	3.1	1.9	2.9	1.8
0.7	3.4	2.1	3.1	1.9
1.0	4.1	2.5	3.5	2.2
1.5	5.4	3.4	5.4	3.4
1.7	6.0	3.7	6.0	3.7
2.0	7.1	4.4	7.1	4.4
2.5	9.5	5.9	9.5	5.9
2.7	10.5	6.5	10.5	6.5
	12.2	7.6	12.2	7.6

\*Meets Tier 4 Final/Stage IV/Japan 2014 (Tier 4 Final) emission standards.

## TRAVEL SPEED

POWER SHIFT MODEL	Differential Steer		D8T		D9R		D9T		D10T2		D11T/CD		D11T/CD High Altitude	
	km/h	mph	km/h	mph	km/h	mph	km/h	mph	km/h	mph	km/h	mph	km/h	mph
FORWARD														
1	3.5	2.2	3.4	2.1	3.8	2.4	3.9	2.4	4.0	2.5	3.9	2.4	4.0	2.5
2	6.2	3.9	6.0	3.7	6.8	4.2	6.8	4.2	7.2	4.5	6.8	4.2	7.0	4.4
3	10.8	6.7	10.6	6.6	11.9	7.4	11.7	7.3	12.7	7.9	11.8	7.3	12.0	7.5
REVERSE														
1	4.7	2.9	4.5	2.8	4.7	2.9	4.7	2.9	5.2	3.2	4.7	2.9	4.8	3.0
2	8.1	5.0	7.9	4.9	8.4	5.2	8.4	5.2	9.0	5.6	8.2	5.1	8.3	5.2
3	13.9	8.6	14.2	8.8	14.7	9.1	14.3	8.9	15.8	9.8	14.0	8.7	14.9	9.0

GEAR	D6T Powershift with AutoShift		D6T Powershift with AutoShift – Sound Suppressed	
	km/h	mph	km/h	mph
FORWARD				
0.5	2.7	1.7	2.7	1.7
0.7	3.3	2.0	3.2	2.0
1.0	3.7	2.3	3.2	2.0
1.5	4.7	2.9	4.7	2.9
1.7	5.7	3.6	5.7	3.6
2.0	6.5	4.0	6.3	3.9
2.5	8.2	5.1	8.2	5.1
2.7	10.0	6.2	10.0	6.2
3.0	11.3	7.0	10.9	6.8
REVERSE				
0.5	3.5	2.2	3.5	2.2
0.7	4.2	2.6	3.9	2.4
1.0	4.7	2.9	3.9	2.4
1.5	6.0	3.7	6.0	3.7
1.7	7.3	4.5	7.3	4.5
2.0	8.3	5.1	8.0	5.0
2.5	10.4	6.5	10.4	6.5
2.7	12.7	7.9	12.7	7.9
3.0	14.4	9.0	13.8	8.6



## GROUND PRESSURES

Pressures computed from operating weights given earlier in this section in the specifications tables.

MODEL	SHOE WIDTH		CONTACT AREA		GROUND PRESSURE	
	mm	in	m <sup>2</sup>	in <sup>2</sup>	kPa	psi
D3K2 XL <sup>1</sup>	406	16	1.70	2637	44.80	6.50
D3K2 LGP <sup>1</sup>	635	25	2.70	4124	29.70	4.30
D3K2 XL	406	16	1.70	2637	44.80	6.50
D3K2 LGP	635	25	2.70	4124	29.70	4.30
D4K2 XL <sup>1</sup>	460	18	2.10	3206	38.60	5.60
D4K2 LGP <sup>1</sup>	635	25	2.90	4425	29.20	4.24
D4K2 XL	460	18	2.10	3206	38.60	5.60
D4K2 LGP	635	25	2.90	4425	29.20	4.24
D5K2 XL <sup>1</sup>	510	20	2.40	3652	39.10	5.67
D5K2 LGP <sup>1</sup>	660	26	3.00	4726	31.10	4.52
D5K2 XL	510	20	2.40	3652	39.10	5.67
D5K2 LGP	660	26	3.00	4726	31.10	4.52
D5R2 XL <sup>1</sup>	560	22	2.89	4480	57.69	8.20
	600	23.6	3.13	4806	53.27	7.65
	610	24	3.18	4929	52.43	7.46
D5R2 LGP <sup>1</sup>	840	33	5.24	8117	35.47	5.05
	865	34	5.39	8385	34.48	4.89
D5T <sup>1</sup>	560	22	2.89	4480	57.69	8.20
	600	23.6	3.13	4806	53.27	7.65
	610	24	3.18	4929	52.43	7.46
D6K2 XL	510	20	2.70	4185	46.82	6.79
(Standard shoe)	560	22	3.00	4650	42.13	6.11
D6K2 LGP	610	24	3.20	4960	41.30	5.99
(Standard shoe)	760	30	4.00	6200	33.02	4.79
D6N XL <sup>2</sup>	610	24	3.18	4929	51.70	7.49
D6N LGP <sup>2</sup>	840	33	5.24	8122	34.20	4.96

<sup>1</sup> Meets Tier 3/Stage IIIA/Japan 2006 (Tier 3) equivalent emission standards.

<sup>2</sup> Meets Tier 4 Final/Stage IV/Japan 2014 (Tier 4 Final) emission standards.

MODEL	SHOE WIDTH		CONTACT AREA		GROUND PRESSURE	
	mm	in	m <sup>2</sup>	in <sup>2</sup>	kPa	psi
D6R2 STD <sup>1</sup>	560	22	2.98	4625	62.40	9.05
	610	24	3.25	5038	57.28	8.31
D6R2 XL <sup>1</sup>	560	22	3.22	4984	60.70	8.80
	610	24	3.50	5429	55.72	8.08
D6R2 LGP <sup>1</sup>	915	36	5.99	9290	35.40	5.13
	1000	39.37	6.55	10,153	32.39	4.70
D6T XL <sup>2</sup>	560	22	3.20	4922	64.82	9.40
	610	24	3.49	5369	59.43	8.62
D6T XW <sup>2</sup>	610	24	3.48	5390	61.45	8.91
	710	28	4.06	6289	52.66	7.64
	760	30	4.35	6738	49.15	7.13
D6T LGP <sup>2</sup>	760	30	4.98	7729	45.05	6.53
	915	36	5.98	9275	37.52	5.44
	991	39	6.48	10,048	34.65	5.02
D6T XL VPAT <sup>2</sup>	560	22	3.20	4922	73.1	10.60
	610	24	3.49	5369	66.9	9.70
D6T XW VPAT <sup>2</sup>	710	28	4.65	7214	51.0	7.40
D6T LGP VPAT <sup>2</sup>	790	31	5.18	8034	46.2	6.70

<sup>1</sup> Meets Tier 2/Stage II/Japan 2001 (Tier 2) or Tier 3/Stage IIIA/Japan 2006 (Tier 3) equivalent emission standards.

<sup>2</sup> Meets Tier 4 Final/Stage IV/Japan 2014 (Tier 4 Final) emission standards.

**NOTE:** Ground contact area = width of track shoe  
× length of track on ground × 2.

$$\text{Ground pressure} = \frac{\text{operating weight}}{\text{ground contact area}}$$

## GROUND PRESSURES

Pressures computed from operating weights given earlier in this section in the specifications tables.

MODEL	SHOE WIDTH		CONTACT AREA		GROUND PRESSURE	
	mm	in	m <sup>2</sup>	in <sup>2</sup>	kPa	psi
D7E <sup>1</sup>	560	22	3.37	5231	75.71	10.98
	◀ 610	24	3.68	5698	69.51	10.08
	660	26	3.98	6165	64.24	9.32
D7E LGP <sup>1</sup>	915	36	6.31	9792	44.28	6.42
D7R	◀ 560	22	3.24	5016	75.10	10.56
	610	24	3.53	5472	69.00	9.76
D7R XR	◀ 560	22	3.43	5315	70.60	10.03
	610	24	3.75	5808	65.90	9.26
D7R LGP	914	36	5.82	9029	45.50	6.48
D8R	◀ 610	24	3.91	6062	95.11	13.79
	660	26	4.23	6559	87.90	12.75
	710	28	4.55	7056	81.48	11.81
D8R LGP	965	38	6.29	9746	54.88	7.96
D8T	◀ 610	24	3.91	6062	99.69	14.46
	660	26	4.23	6559	92.14	13.36
	710	28	4.55	7056	85.65	12.42
D8T LGP	965	38	6.19	9593	59.83	8.68
D8T <sup>1</sup>	610	24	3.91	6062	99.81	14.47
	660	26	4.23	6559	92.25	13.38
	710	28	4.55	7056	85.75	12.43
D8T LGP <sup>1</sup>	965	38	6.19	9593	59.90	8.68

◀Standard shoe.

<sup>1</sup> Meets Tier 4 Interim/Stage IIIB/Japan 2011 (Tier 4 Interim) equivalent emission standards.

MODEL	SHOE WIDTH		CONTACT AREA		GROUND PRESSURE	
	mm	in	m <sup>2</sup>	in <sup>2</sup>	kPa	psi
D9R/D9T	560	22	3.89	6031	121.8	17.67
	◀ 610	24	4.24	6569	111.80	16.22
	685	27	4.74	7374	99.60	14.45
	760	30	5.28	8185	89.80	13.02
D10T2	◀ 610	24	4.74	7347	145.25	21.06
	710	28	5.52	8551	124.49	18.06
	760	30	5.91	9153	116.19	16.85
D11T	◀ 710	28	6.31	9781	161.98	23.49
	810	32	7.20	11,159	141.99	20.59
	915	36	8.13	12,605	125.69	18.23
D11T CD	810	32	7.20	11,159	153.54	22.27
	◀ 915	36	8.13	12,605	135.92	19.71

**NOTE:** Ground contact area = width of track shoe × length of track on ground × 2.

$$\text{Ground pressure} = \frac{\text{operating weight}}{\text{ground contact area}}$$

## EXTREME SLOPE OPERATION

The maximum fore and aft grade in static condition on which each track-type tractor or pipelayer will maintain proper lubrication is 45 degrees (100%). Consult Operation & Maintenance Manual (if applicable) for POWER TRAIN fluid level overfill requirements for operation on extreme slopes. Extreme slope operation is anytime the slope exceeds 25° (47%).

When working sidehills and slopes, consideration should be given to the following important points:

- Speed of travel — At higher speeds, inertia forces tend to make the tractor less stable.
- Roughness of terrain or surface — Ample allowance should be made where the terrain or surface is uneven.
- Mounted equipment — Bulldozers, sidebooms, winches, and other mounted equipment cause the tractor to balance differently.
- Nature of surface — New earthen fills may give way with the weight of the tractor. Rocky surfaces may promote side slipping of tractor.
- Track slippage due to excessive loads — This may cause downhill track to “dig in,” increasing angle of tractor.

The ENGINE should never be overfilled with oil. This may lead to rapid overheating. For extreme slope operation, engine oil should be maintained at the full mark.

**NOTE:** Both ENGINE and POWER TRAIN fluid levels should be checked on level ground before working sidehills and slopes.

- Implements hitched to the drawbar — This may decrease weight on uphill track, e.g., logging arch, two-wheel wagon.
- Height of hitch on tractor — When a high drawbar is used the tractor is less stable than with the standard drawbar.
- Width of shoes — Wide track shoes tend to decrease “digging in”, hence tractor is more stable.
- Operated equipment — Be aware of the stability and other performance features of the equipment operated by the tractor.
- Keep all attachments or pulled loads low to the ground for optimum stability.

**NOTE:** Safe operation on steep slopes may require special machine maintenance as well as excellent operator skill and proper equipment for the specific application. Consult Operation & Maintenance Manual (if applicable) for proper fluid level requirements.

# HYDRAULIC CONTROLS

## CONTENTS

Features .....19-29  
 Specifications .....19-30

### Features:

- **Designed and built for specific tractor applications.** Valves and components sized for exacting quality and performance.
- **Job requirements matched** through various arrangements.
- **Hydraulic blade and ripper controls:** Mechanical controls on G Series. Electro hydraulic controls on D6N and D6K2. Pilot blade and ripper controls on D6T Tier 3/Stage IIIA, Japan 2006 (Tier 3) equivalent with optional electro hydraulic blade control. Electro hydraulic blade and ripper controls on D6T Tier 4 Interim/Stage IIIB/Japan 2011 (Tier 4 Interim) equivalent Mechanical controls on D9R. Electro hydraulic blade and ripper controls on D7E, D8T, D9T, D10T2, and D11T.
- **Full flow filters\***... all oil completely filtered.
- **Dual tilt** — standard on D11T and D11T CD, attachment option on D7E, D8R, D8T, D9R, D9T, D10T2.

\*Exception — D8R 2-pump.

MODEL	D3K2		D3K2		D4K2		D4K2	
Mounting Point	Fender		Fender		Fender		Fender	
Number of Valves	3 or 4		3 or 4		3 or 4		3 or 4	
Flow at 6890 kPa (1000 psi)	73.5 L/min	19.4 gpm	73.5 L/min	19.4 gpm	73.5 L/min	19.4 gpm	73.5 L/min	19.4 gpm
	@ 2150 RPM		@ 2150 RPM		@ 2150 RPM		@ 2150 RPM	
Tank Capacity (Oil)	59.5 L	15.7 U.S. gal	59.5 L	15.7 U.S. gal	59.5 L	15.7 U.S. gal	59.5 L	15.7 U.S. gal
Lift Relief Valve Setting	20 600 kPa	2988 psi	20 600 kPa	2988 psi	20 600 kPa	2988 psi	20 600 kPa	2988 psi
Weight Installed:								
4 Valves	39 kg	86 lb*	39 kg	86 lb*	39 kg	86 lb*	39 kg	86 lb*

MODEL	D5K2		D5K2		D5R2/D5T	
Mounting Point	Fender		Fender		Under Operator's Platform	
Number of Valves	3 or 4		3 or 4		2, 3, or 4	
Flow at 6890 kPa (1000 psi)	73.5 L/min	19.4 gpm	73.5 L/min	19.4 gpm	135 L/min	35.7 gpm
	@ 2150 RPM		@ 2150 RPM		@ 2200 RPM	
Tank Capacity (Oil)	59.5 L	15.7 U.S. gal	59.5 L	15.7 U.S. gal	29.5 L	7.8 U.S. gal
Lift Relief Valve Setting	20 600 kPa	2988 psi	20 600 kPa	2988 psi	26 500 kPa	3843 psi
Weight Installed:						
2 Valves	—		—		27.26 kg	60.1 lb
3 Valves	—		—		31.25 kg	68.9 lb
4 Valves	39 kg	86 lb*	39 kg	86 lb*	36.19 kg	79.8 lb

MODEL	D6K2		D6N <sup>1</sup>		D6R2 <sup>3</sup>		D6R2 <sup>4</sup>	
Mounting Point	Under Operator's Platform		Right Rear Fender		Under Operator's Platform		Under Operator's Platform	
Number of Valves	3 or 4		3 or 4		2 or 3		2 or 3	
Flow at 6890 kPa (1000 psi)	120 L/min	31.7 gpm	132.5 L/min	35.0 gpm	203 L/min	53.6 gpm	188 L/min	49.7 gpm
	@ 2100 RPM		@ 2300 RPM		@ 2120 RPM		@ 1961 RPM	
Tank Capacity (Oil)	58 L	15.3 U.S. gal	29.5 L	7.8 U.S. gal	51.5 L	13.6 U.S. gal	51.5 L	13.6 U.S. gal
Lift Relief Valve Setting	—		—		19 300 kPa	2799 psi	19 300 kPa	2799 psi
XL and LGP	26 000 kPa	3771 psi	27 500 kPa	3989 psi	—		—	
Weight Installed:								
2 Valves	—		—		61.33 kg	135.2 lb	61.33 kg	135.2 lb
3 Valves	30 kg	66 lb	27 kg	59.5 lb	77.83 kg	171.6 lb	77.83 kg	171.6 lb
4 Valves	37 kg	81.6 lb	32 kg	70.5 lb	—		—	

MODEL	D6T		D6T <sup>2</sup>		D6T VPAT <sup>2</sup>		D7E (Differential Steer)	
Mounting Point	Under Operator's Platform		Under Operator's Platform		Under Operator's Platform		Blade Control under Hood, Ripper on Rear	
Number of Valves	2, 3, or 4		2, 3, or 4		3 or 4		2 Std. 4 with Ripper	
Flow at 6890 kPa (1000 psi)	205 L/min	54 gpm	205 L/min	54 gpm	205 L/min	54 gpm	204 L/min	54 gpm
	@ 2010 RPM		@ 2010 RPM		@ 2010 RPM		@ 2124 RPM (PMP)	
Tank Capacity (Oil)	47.3 L	12.5 U.S. gal	96 L	25.4 U.S. gal	96 L	25.4 U.S. gal	66 L	17.4 U.S. gal
Lift Relief Valve Setting	19 300 kPa	2800 psi	19 300 kPa	2800 psi	21 550 kPa	3125 psi	27 600 kPa	4000 psi
Weight Installed:								
2 Valves	Included in Std. Tractor		Included in Std. Tractor		—		Included in Std. Tractor	
3 Valves	—		—		Included in Std. Tractor		—	

\*Hydraulic tank not included.

<sup>1</sup> Meets Tier 4 Final/Stage IV/Japan 2014 (Tier 4 Final) emission standards.

<sup>2</sup> Meets Tier 4 Interim/Stage IIIB/Japan 2011 (Tier 4 Interim) equivalent emission standards.

<sup>3</sup> Meets Tier 2/Stage II/Japan 2001 (Tier 2) equivalent emission standards.

<sup>4</sup> Meets Tier 3/Stage IIIA/Japan 2006 (Tier 3) equivalent emission standards.

**NOTE:** Weight installed, two valves, includes pump, tank with filters, valves, lines, linkage, oil cooler and control levers.

MODEL	D7R (Differential Steer)	D8R	D8T	D9R
Mounting Point	Under Operator's Platform	Under Operator's Platform	At Rear Center of Fuel Tank	Under Operator's Platform
Number of Valves	3 or 5	2 Std. 4 with Ripper◀ Pilot Control System	2 Std., 3 with Winch, 4 with Ripper, 5 with Implement Towing AR Electro/Hydraulic Control System	4 + Dual Tilt (Attach.) Radiator Guard Mechanical Control System
Flow at 6890 kPa (1000 psi)	289 L/min 76 gpm @ 2100 RPM	240 L/min 63 gpm @ 2100 RPM (PMP)	282 L/min 74.5 gpm @ 2200 RPM	239 L/min 63 gpm @ 1900 RPM
Tank Capacity (Oil)	54 L 14.3 U.S. gal	72 L 19 U.S. gal	75 L 19.8 U.S. gal	77.2 L 20.4 U.S. gal
Lift Relief Valve Setting	22 750 kPa 3300 psi	24 100 kPa 3500 psi	24 000 kPa 3481 psi	26 200 kPa 3800 psi
Weight Installed	358 kg 784 lb (Two Valves)	Included in Std. Tractor (Two Valves)	Included in Std. Tractor	Included in Std. Tractor (Two Valves)
MODEL	D9T	D10T2	D11T	D11T CD
Mounting Point	Under Operator's Platform	Under Operator's Platform	Under Operator's Platform	Under Operator's Platform
Number of Valves	4 + Dual Tilt (Attach.) Electro/Hydraulic Control System	5 Single Tilt 6 Dual Tilt	4 At Rear Under Fuel Tank 1◀ + Dual Tilt Standard Radiator Guard	4 At Rear Under Fuel Tank 1◀ Dual Tilt Standard Quick Dump Valve Standard Both on Radiator Guard
Flow at 6890 kPa (1000 psi)	258 L/min 68 gpm @ 2010 RPM	380 L/min 100.4 gpm @ 1800 RPM	620 L/min 164 gpm @ 1800 RPM	670 L/min 177 gpm @ 1800 RPM
Tank Capacity (Oil)	89 L 23.5 U.S. gal	131 L 34.6 U.S. gal	223 L 58.9 U.S. gal	223 L 58.9 U.S. gal
Lift Relief Valve Setting	26 200 kPa 3800 psi	—	—	—
Lift	—	28 000 kPa 4061 psi	22 753 kPa 3300 psi	24 132 kPa 3500 psi
Tilt	—	20 300 kPa 2944 psi	24 304 kPa 3525 psi	24 821 kPa 3600 psi
Weight Installed	Included in Std. Tractor	Included in Std. Tractor (Six Valves)	Included in Std. Tractor	Included in Std. Tractor

◀Ripper valve.

NOTE: Weight installed, two valves, includes pump, tank with filters, valves, lines, linkage, oil cooler and control levers.



# BULLDOZERS

## CONTENTS

Features .....	19-33
Summary of Blade Options.....	19-34
Blade Selection .....	19-36
General Dimensions (Tractor and Blade).....	19-39
SAE Blade Capacity Definition .....	19-39
Blade Specifications.....	19-40
Estimating Production Off-the-Job.....	19-50
Job Condition Correction Factors .....	19-55
Measuring Production On-the-Job.....	19-56
Attachments.....	19-56
Special Attachments .....	19-57

## Features:

- **Straight Bulldozers** — adjustable tilt angle controls blade penetration.
- **Variable cutting edge Power Angle and Tilt (VPAT)** — blade is available on the D3K2, D4K2, D5K2, D6K2, D6N, and D6T. The blade can be mechanically tipped forward for improved penetration or back for more productivity and easier finish grading.
- **Angling Bulldozers** — 25° right/left angling; C-frame allows mounting other tools.
- **Universal Bulldozers** — 25° wings provide increased capacity, less spillage.
- **Semi-Universal Bulldozers** — combines penetration ability of straight blade with increased load capacity provided by short 25° wings.
- **Wheel Dozer blades** are offered in straight and universal blade design with hydraulic pitch and tilt control.
- **Box-section construction** on blades adds rigidity and strength.
- **Cutting edges** are heat treated and reversible for extra life.



MODEL	CAT BLADES										SPECIAL BLADES											
	S	U	SU	A	FS	LFS	VP	CD	RC	WC	CL	HU	LF	TW	CU	CPB	CB	VR	WCB	CS	WCS	W
D3K2 XL <sup>2</sup>							●															
D3K2 LGP <sup>2</sup>							●															
D3K2 XL							●															
D3K2 LGP							●															
D4K2 XL <sup>2</sup>							●															
D4K2 LGP <sup>2</sup>							●															
D4K2 XL							●															
D4K2 LGP							●															
D5K2 XL <sup>2</sup>							●															
D5K2 LGP <sup>2</sup>							●															
D5K2 XL							●															
D5K2 LGP							●															
D5E				●																		
D5R2 XL			●	●			●						●									
D5R2 LGP	●						●						●									
D5T XL		●					●						●									
D6K2 XL							●															
D6K2 LGP							●															
D6N XL <sup>1</sup>			●				●						●									
D6N LGP <sup>1</sup>							●						●									
D6R	●		●	●																		
D6R XL			●	●									●									
D6R LGP	●												●									
D6R2	●		●	●																		
D6R2 XL			●	●									●									
D6R2 LGP	●												●									
D6R Series 3	●		●	●						●	●		●					●				
D6R Series 3 XL			●	●			●															
D6R Series 3 LGP	●						●			●	●		●						●			
D6R Series 3 XW			●	●			●															
D6T XL			●	●			●			●			●						●			
D6T LGP	●			●			●			●	●		●						●			
D6T XW			●	●			●			●			●									

<sup>1</sup> Meets Tier 4 Final/Stage IV/Japan 2014 (Tier 4 Final) emission standards.  
<sup>2</sup> Meets Tier 3/Stage IIIA/Japan 2006 (Tier 3) equivalent emission standards.

**CATERPILLAR SUPPLIED**

- S – Straight
- U – Universal
- SU – Semi-Universal
- A – Angling
- FS – Fill Spreading
- LFS – Landfill Spreading
- VP – Variable Pitch, Lower, Angle and Tilt (VPAT)

**SPECIAL SUPPLIED**

- RC – Reclamation U
- WC – Woodchips
- CL – Coal
- HU – Heavy U
- LF – Landfill
- CD – Carry Dozer
- TW – Two-Way Dozer
- CU – Cushion Dozer
- CPB – Cushion Push Block
- CB – Coal Bowldozer
- VR – Variable Radius
- WCB – Wood Chip Bowldozer
- CS – Coal Scoop
- WCS – Wood Chip Scoop
- W – W-Blade

**NOTE:** This chart suggests a range of blade options for Caterpillar built machines. It is not totally inclusive of all blades available.

MODEL	CAT BLADES									SPECIAL BLADES													
	S	U	SU	A	FS	LFS	VP	CD	RC	WC	CL	HU	LF	TW	CU	CPB	CB	VR	WCB	CS	WCS	W	
D7E	●	●	●	●						●													
D7E LGP	●									●													
D7R			●	●									●										
D7R XR			●	●									●										
D7R LGP	●												●										
D7R Series 2	●	●	●	●						●	●		●	●					●				
D7R Series 2 LGP	●												●						●				
D7G Series 2	●		●	●																			
D8R		●	●	●					●	●	●		●		●	●			●				
D8R LGP		●	●										●										
D8T		●	●	●					●	●	●		●		●				●				
D8T LGP		●	●										●										
D9R/D9T		●	●						●	●	●		●		●	●	●			●			
D10T2		●	●						●	●	●		●		●	●	●						
D11T		●	●						●		●												
D11T CD								●															
814F	●										●	●								●	●		
815F					●																		
816F						●							●										●
824G/824H	●									●	●	●										●	
825G					●																		
826G/826H						●							●										●
834G/834H	●	●								●	●									●	●		
836G/836H													●										●

**CATERPILLAR SUPPLIED**

- S – Straight
- U – Universal
- SU – Semi-Universal
- A – Angling
- FS – Fill Spreading
- LFS – Landfill Spreading
- VP – Variable Pitch, Lower, Angle and Tilt (VPAT)

**SPECIAL SUPPLIED**

- RC – Reclamation U
- WC – Woodchips
- CL – Coal
- HU – Heavy U
- LF – Landfill
- CD – CarryDozer
- TW – Two-Way Dozer
- CU – Cushion Dozer
- CPB – Cushion Push Block
- CB – Coal Bowl Dozer
- VR – Variable Radius
- WCB – Wood Chip Bowl Dozer
- CS – Coal Scoop
- WCS – Wood Chip Scoop
- W – W-Blade

**NOTE:** This chart suggests a range of blade options for Caterpillar built machines. It is not totally inclusive of all blades available.

**BLADE SELECTION**

Properly matching tractor and dozer is a basic requirement for maximizing production. First consider the kind of work the tractor will be doing most of its life. Then evaluate:

- Material to be moved.
- Tractor limitations.

**Materials to be moved**

Most materials are dozeable. However, dozer performance will vary with material characteristics such as:

*Particle Size and Shape* — The larger the individual particle size, the harder it is for a cutting edge to penetrate. Particles with sharp edges resist the natural rolling action of a dozer blade. These particles require more horsepower to move than a similar volume of material with rounded edges.

*Voids* — Few voids or the absence of voids means the individual particles have most or all of their surface area in contact with other particles. This forms a bond which must be broken. A well graded material, which lacks voids, is generally heavy, and will be hard to remove from the bank state.

*Water Content* — In most materials the lack of moisture increases the bond between particles and makes the material difficult to remove from the bank state. A high moisture content makes dozing difficult because the material is heavy and requires more force to move. Optimum moisture reduces dust and offers the best condition for dozing ease and operator comfort.

The effect of freezing depends on the moisture content. When frozen, the material's bond strengthens as moisture content increases and temperature decreases. However, freezing a completely dry material does not change its characteristics.

An indication of a blade's ability to penetrate and obtain a blade load is kW per meter (or horsepower per foot) of cutting edge. The higher the kW/meter (HP/foot), the more aggressive the blade. Kilowatt per  $\text{Lm}^3$  (horsepower per loose cubic yard) indicates a blade's ability to push material. The higher the kW/ $\text{Lm}^3$  (HP/LCY), the greater the blade's potential capability for carrying material at a greater speed.

**Tractor Limitations**

The weight and horsepower of the machine determines its ability to push. No tractor can exert more pounds push than the machine itself weighs and its power train can develop. Various terrain and underfoot conditions on the job limit the tractor's ability to use its weight and horsepower. The "approximate coefficient of traction factors" chart in the Tables Section presents these traction factors for common materials. To use the chart, take the total tractor weight (with attachments) times the factor to arrive at the maximum usable push the dozer can exert.

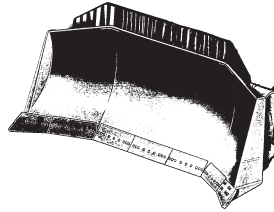
**Production Dozing Tools**

**"U"** — Universal blade — the large wings on this blade include one end bit and at least one section of cutting edge which make it efficient for moving big loads over long distances as in land reclamation, stockpile work, charging hoppers and trapping for loaders.

As this blade has a lower kW/meter (HP/foot) of cutting edge than an "S" or "SU", penetration should not be a prime objective. With a lower kW/ $\text{Lm}^3$  (HP/LCY) than an "S" or "SU", this blade is best for lighter or relatively easily dozed material. If equipped with tilt cylinders the U blade can be used to pry out, level, cut ditches and steer the tractor.

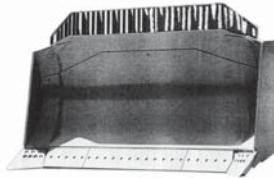

**"SU"** — The Semi-U blade combines the desirable characteristics of S and U-blades into one package. It has increased capacity by the addition of short wings which include only the dozer end bits. The

wings provide improved load retention capabilities while maintaining the blade's ability to penetrate and load quickly in tightly packed materials and to handle a wide variety of materials in production oriented applications. Tilt cylinder(s) increase both the productivity and versatility of this dozer. Equipped with a push plate, it is effectively used for push loading scrapers.

## Blade Selection

- General Purpose Dozing Tools
- Special Application Dozing Tools

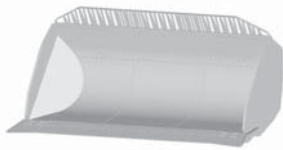

**“CD”** — The CD or Carry-Dozer Blade is available for the D11T CarryDozer only. It is built to the same high standard of structural integrity as the “U” and “SU” Dozers. The CD Blade has

a unique “bucket” shape that allows it to carry several cubic yards or cubic meters of material in the blade. This acts as a disposable counterweight that allows the CarryDozer to push more material per pass than a standard D11T. The CarryDozer will not be as effective as the “U” or “SU” dozer in tightly packed or poorly shot material. It is also more sensitive to the carry-back in sticky materials.

### General Purpose Dozing Tools

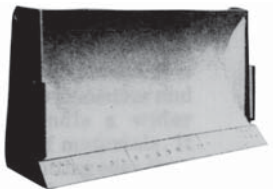

**“S”** — The Straight blade provides excellent versatility. Since it is physically smaller than the SU or U-blade, it is easier to maneuver and can handle a wider range of materials. It has a higher kW/ meter (HP/foot)

of cutting edge than the SU or U-blade; consequently, the “S” is more aggressive in penetrating and obtaining a blade load. A tilt cylinder increases both the productivity and versatility of this dozer. With a high kW/Lm<sup>3</sup> (HP/LCY), the S-blade can handle heavy material easily.



**Power Angle and Tilt Blade** — Versatility is its key feature with its ability to perform a variety of site development to general dozing work as well as heavy-duty applications.

Angle and tilt control is with 2 levers on some machines, 1 lever on others.

Variable Power Angle and Tilt (VPAT) blade can be mechanically tipped forward for improved penetration or shedding sticky material and backward for finish grading and improved productivity.

### Special Application Dozing Tools

Caterpillar provides specialty bulldozers for specific applications. The blades are designed to increase production while performing certain tasks. Following are the most popular special applications blades.

### Variable Radius (VR) Blades

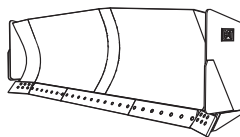

**Variable Radius Semi-U Blades** are excellent tools for land improvement, soil conservation, site development or general construction. They combine the

penetration ability of a Semi-U Blade with the load retention and high capacity of a U-blade.

They provide the aggressive cutting action needed for digging, while having the material retention characteristics needed for moving high volumes over a distance. This is accomplished through a moldboard which varies in radius from the edge to the center. This creates a rolling action in the material being moved, pushing it to the center of the blade for better retention. The extended side wings, angled to thirty degrees, further increase the capacity over a standard blade.

### Angle Blade (A-Blade)



**“A”** — Or Angling blade can be positioned straight or angled 25 degrees to either side. It is designed for side-casting, pioneering roads,

backfilling, cutting ditches and other similar tasks. It can reduce the amount of maneuvering required to do these jobs. Its “C” frame can be used for attachments such as pushing, land clearing, or snow removal tools. A-blades are not recommended for rock or severe applications.

### Cushion Dozers

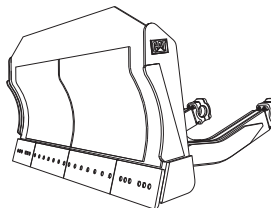

**Cushion Dozers** are designed to push-load wheel-tractor scrapers, or track-type tractors. The heavy-duty design includes reinforcement to transfer machine power without damaging the blade or the

tractor. Blade cylinders are pinned to the C-frame, and the blade height is such that the blade lift cylinders are isolated from damaging forces.

The taller blade allows pushing from a higher position, eliminating blade drag and increasing productivity. The blade curvature is matched to the curve of the Cat Push Block for maximum contact area, preventing the block from riding over the top of the blade. Extended side plates make it easier for operators to “catch” the stinger when repositioning for a new pass. The center of the blade is armored with T-1 plate steel for maximum service life. The narrow width of the cushion blade increases machine maneuverability in congested cuts and reduces the possibility of cutting tires associated with SU and U-blades.

When not push-loading, the dozer can be used for cut maintenance and other general dozing jobs.

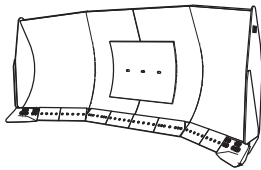

**Coal U-Blades** are designed specifically to move large volumes of coal in coal piles, at powerplants and transshipment points. The wing angle of thirty degrees crowds material to the center of the

blade, maximizing capacity by minimizing side spill. The moldboard is much higher and wider than standard, specifically to match the material density and loading characteristics of coal. The curve of the moldboard rolls the material forward, enhancing the carrying capacity. With this design, coal-moving capacity can be as much as 200 percent greater than a standard U-blade.

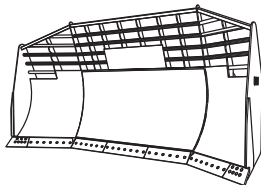

**Landfill U-Blades** provide capacity increases of up to fifty percent over a straight blade. Landfill blades have the height and width to handle large volumes of low-density refuse, but are tough

enough to dig and bulldoze ground cover. Vision to the load is provided by areas of screen in the upper blade. Angled wings slice into natural bed earth for trenches or cover material, adding to the versatility in the landfill.

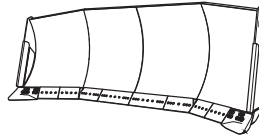

**Reclamation U-Blades** — are purpose-built for reclamation of mine spoil piles. The blade has a larger capacity than a standard U-blade.

The wing angle of 28 degrees provides a good balance between load retention and shearing action, keeping the optimal load in front of the blade, but cutting cleanly through the material when necessary.

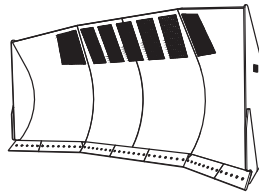

The width of **Woodchip U-Blades** gives operators maximum control and greater confidence, even in steep chip piles. Deep curvature of the moldboard keeps material flowing to live dead chips and optimize production on

long pushes. Blade height and wings angled at thirty degrees combine for excellent material retention – giving better production with every pass. An operator visibility window in the top section is standard.

**Multi-Application/Rock and Root Rakes**

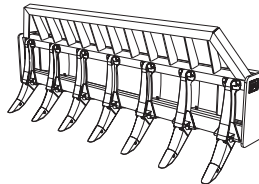

**Multi-Application/Rock and Root Rakes** are perfectly suited for heavy duty land clearing including removal of stumps, large rocks or large trees and for work in clay and other heavy soils.

Frames are constructed of high strength steel for longer life. Cast teeth, with replaceable tips, are designed for maximum ground penetration and resistance to shock loading when prying or pushing trees, stumps and rocks. Brush rack is standard and increases height and capacity by as much as 40%.

Rake is a direct replacement for existing blade, and utilizes existing push arms and C-frames.

- Tractor and Blade
- SAE Blade Capacity Definition

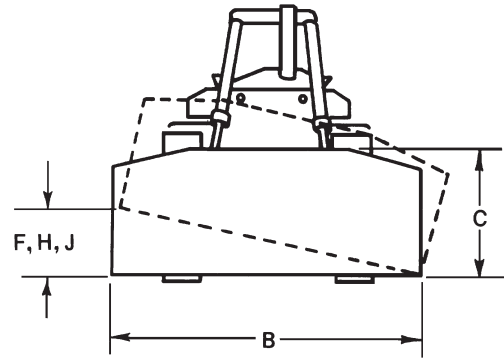
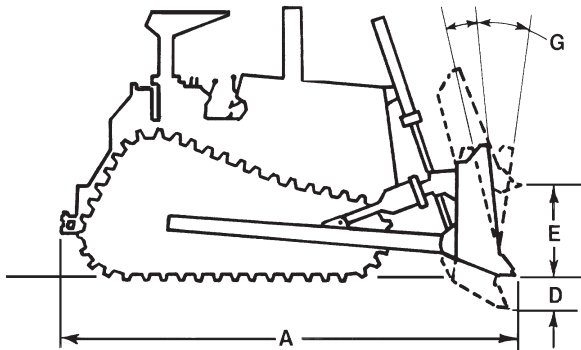

KEY

- A** Length (Blade Straight)  
Blade:
- B** Width (including standard end bits)
- C** Height
- D** Maximum Digging Depth
- E** Ground Clearance @ Full Lift
- F** Maximum Tilt (Manual)
- G** Maximum Pitch Adjustment
- H** Maximum Hydraulic Tilt
- J** Hydraulic Tilt (manual brace centered)
- K** Push Arm Trunnion Width (to Ball Centers)

Blade capacities on the following pages are as determined by SAE recommended practice J1265. Capacities are defined as:

$$V_s = 0.8 WH^2$$

$$V_u = ZH(W-Z) \tan X$$

Where:  $V_s$  = Capacity of straight or angling blade.

$V_u$  = Capacity of semi-U or full U-blade.

$W$  = Blade width exclusive of end bits.

$H$  = Effective blade height considering tapered top corners, etc.

$Z$  = Wing length measured parallel to blade width @ ground line of cutting edges.

$X$  = Wing angle.

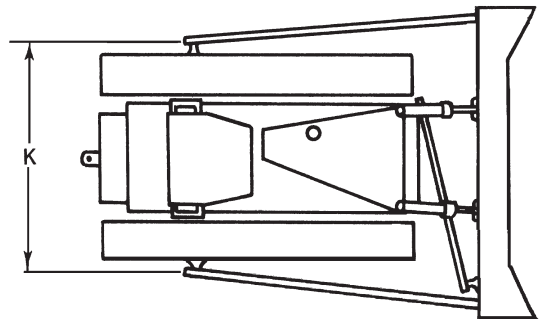

# Bulldozers

## Blade Specifications

● D3K2 ● D4K2 ● D5K2

MODEL	D3K2***				D4K2***			
	XL		LGP		XL		LGP	
Type	Variable Power Angling and Tilt		Variable Power Angling and Tilt		Variable Power Angling and Tilt		Variable Power Angling and Tilt	
Blade Capacities*	1.52 m <sup>3</sup>	1.99 yd <sup>3</sup>	1.66 m <sup>3</sup>	2.17 yd <sup>3</sup>	1.98 m <sup>3</sup>	2.59 yd <sup>3</sup>	1.85 m <sup>3</sup>	2.42 yd <sup>3</sup>
Weight Shipping** (Dozer)	572 kg	1261 lb	630 kg	1389 lb	642 kg	1415 lb	661 kg	1457 lb
Tractor and Dozer Dimensions:								
A Length (Blade Straight)	4266 mm	168.0"	4255 mm	167.6"	4274 mm	168.3"	4266 mm	168.0"
Length (Blade Angled)	4763 mm	187.5"	4854 mm	191.1"	4795 mm	188.8"	4873 mm	191.8"
Width (Blade Angled)	2417 mm	95.1"	2874 mm	113"	2542 mm	100"	2874 mm	113"
Blade Dimensions:								
B Width (including std. end bits)	2646 mm	104.1"	3149 mm	124.0"	2782 mm	109.5"	3149 mm	124.0"
C Height	910 mm	35.8"	860 mm	33.8"	1010 mm	39.8"	910 mm	35.8"
D Max. Digging Depth	573 mm	22.5"	573 mm	22.5"	572 mm	22.5"	590 mm	23.2"
E Ground Clearance @ Full Lift	730 mm	28.7"	730 mm	28.7"	743 mm	29.3"	708 mm	27.9"
G Max. Pitch Adjustment	52° to 58°		52° to 58°		52° to 58°		52° to 58°	
J Hydraulic Tilt	368 mm	14.4"	438 mm	17.2"	387 mm	15.2"	438 mm	17.2"
Blade Angle	25°		25°		25°		25°	

MODEL	D5K2***			
	XL		LGP	
Type	Variable Power Angling and Tilt		Variable Power Angling and Tilt	
Blade Capacities*	2.19 m <sup>3</sup>	2.86 yd <sup>3</sup>	2.34 m <sup>3</sup>	3.06 yd <sup>3</sup>
Weight Shipping** (Dozer)	706 kg	1556 lb	728 kg	1605 lb
Tractor and Dozer Dimensions:				
A Length (Blade Straight)	4321 mm	170.1"	4294 mm	169.1"
Length (Blade Angled)	4864 mm	191.5"	4908 mm	193.2"
Width (Blade Angled)	2636 mm	103.8"	2940 mm	115.8"
Blade Dimensions:				
B Width (including std. end bits)	2782 mm	109.5"	3220 mm	126.7"
C Height	1050 mm	41.3"	1010 mm	39.8"
D Max. Digging Depth	586 mm	23.1"	572 mm	22.5"
E Ground Clearance @ Full Lift	767 mm	30.2"	767 mm	30.2"
G Max. Pitch Adjustment	52° to 58°		52° to 58°	
J Hydraulic Tilt	402 mm	15.8"	448 mm	17.6"
Blade Angle	25°		25°	

\*Blade capacities as determined by SAE J1265.

\*\*Shipping Weight — Total Bulldozer Arrangement includes: Blade, push arms or C-frame, braces, cylinders, lines, trunnions and lift cylinder mountings.

\*\*\*Meets Tier 3/Stage IIIA/Japan 2006 (Tier 3) equivalent emission standards.

MODEL	D5R2 XL					
	ANGLE		SU		VPAT XL	
Type	Angle Blade		Semi-Universal		Variable Pitch Power Angle and Tilt	
Blade Capacities*	3.18 m <sup>3</sup>	4.16 yd <sup>3</sup>	4.28 m <sup>3</sup>	5.6 yd <sup>3</sup>	3.31 m <sup>3</sup>	4.33 yd <sup>3</sup>
Weight Shipping** (Dozer)	2546 kg	5612 lb	2600 kg	5732 lb	2375 kg	5236 lb
Tractor and Dozer Dimensions:						
A Length (Blade Straight)	5193 mm	17.04'	5157 mm	16'11"	5035 mm	16'6.2"
Length (Blade Angled)	6011 mm	19.72'	—	—	5680 mm	18'7.6"
Width (Blade Angled)	3785 mm	12.42'	—	—	2990 mm	9'9.7"
Width (with C-Frame only)	2918 mm	9.57'	—	—	2500 mm	8'2.4"
Blade Dimensions:	(outside mounted)		(outside mounted)		(inside mounted)	
B Width (including std. end bits)	4165 mm	13.66'	3154 mm	10'4.2"	3272 mm	10'8.8"
C Height	1034 mm	3.39'	1244 mm	4'1"	1195 mm	3'11"
D Max. Digging Depth	534 mm	1.75'	520 mm	1'8.5"	420 mm	1'4.5"
E Ground Clearance @ Full Lift	1098 mm	3.60'	983 mm	3'2.7"	1067 mm	3'6"
G Max. Pitch Adjustment	—	—	±5°	—	55.7° to 62.5°	
J Hydraulic Tilt	—	—	665 mm	2'2.2"	485 mm	1'7.1"
Blade Angle	25°		—		24.1°	

MODEL	D5R2 LGP		D6K2 XL		D6K2 LGP	
	VPAT LGP		VPAT XL		VPAT LGP	
Type	Variable Pitch Power Angle and Tilt		Variable Pitch Power Angle and Tilt		Variable Pitch Power Angle and Tilt	
Blade Capacities*	3.87 m <sup>3</sup>	5.06 yd <sup>3</sup>	3.07 m <sup>3</sup>	4.01 yd <sup>3</sup>	3.35 m <sup>3</sup>	4.38 yd <sup>3</sup>
Weight Shipping** (Dozer)	2740 kg	6041 lb	—	—	—	—
Tractor and Dozer Dimensions:						
A Length (Blade Straight)***	5398 mm	17'8.5"	5008 mm	197"	5008 mm	197"
Length (Blade Angled)	6083 mm	19'11.5"	5369 mm	211"	5399 mm	212"
Width (Blade Angled)	3727 mm	12'2.7"	2878 mm	113.3"	3337 mm	131.4"
Width (with C-Frame only)	3000 mm	9'10.1"	2330 mm	92"	2760 mm	109"
Blade Dimensions:	(inside mounted)		(inside mounted)		(inside mounted)	
B Width (including std. end bits)	4082 mm	13'4.7"	3196 mm	10'6"	3682 mm	12'0"
C Height	1040 mm	3'4.9"	1294 mm	50.9"	1294 mm	50.9"
D Max. Digging Depth	500 mm	1'7.7"	468 mm	18.4"	468 mm	18.4"
E Ground Clearance @ Full Lift	1052 mm	3'5.4"	1203 mm	3'10.8"	1201 mm	3'11.3"
G Max. Pitch Adjustment	54° to 62°		6°		6°	
H Max. Hydraulic Tilt	585 mm	1'11"	488 mm	1'7.2"	525 mm	1'8.4"
Blade Angle	24.1°		25°		25°	

\*Blade capacities as determined by SAE J1265.

Notice that the capacity of the SU-blade is the volume carried by a straight blade of the same dimensions plus the volume included in the "cup" of the SU-blade. It is intended for **relative comparisons of dozer sizes**, and not for predicting capacities or productivities in actual field conditions.

\*\*Shipping Weight — Total Bulldozer Arrangement includes: Blade, push arms or C-frame, braces, cylinders, lines, trunnions and lift cylinder mountings.

\*\*\*With rear drawbar.



MODEL	D6N XL***				D6N LGP***	
	6SU		6VPAT XL		6VPAT LGP	
Type	Semi-Universal		Variable Pitch Power Angle and Tilt		Variable Pitch Power Angle and Tilt	
Blade Capacities*	4.28 m <sup>3</sup>	5.6 yd <sup>3</sup>	3.31 m <sup>3</sup>	4.33 yd <sup>3</sup>	3.87 m <sup>3</sup>	5.06 yd <sup>3</sup>
Weight, Shipping** (Dozer)	2600 kg	5732 lb	2375 kg	5236 lb	2740 kg	6041 lb
Tractor and Dozer Dimensions:						
A Length (Blade Straight)	5157 mm	16'11"	5035 mm	16'6.2"	5398 mm	17'8.5"
Length (Blade Angled)	—	—	5680 mm	18'7.6"	6243 mm	20'5.8"
Width (Blade Angled)	—	—	2965 mm	116.7"	3699 mm	145.6"
Width (with C-Frame only)	—	—	2545 mm	100"	2965 mm	116.7"
Blade Dimensions:						
	(outside mounted)		(inside mounted)		(inside mounted)	
B Width (including std. end bits)	3154 mm	10'4.2"	3272 mm	10'8.8"	4082 mm	13'4.7"
C Height	1244 mm	4'1"	1195 mm	3'11"	1040 mm	3'4.9"
D Max. Digging Depth	520 mm	1'8.5"	420 mm	1'4.5"	500 mm	1'7.7"
E Ground Clearance @ Full Lift	983 mm	3'2.7"	1067 mm	3'6"	1052 mm	3'5.4"
G Max. Pitch Adjustment	±5°		55.7° to 62.5°		54° to 62°	
H Max. Hydraulic Tilt	665 mm	2'2.2"	485 mm	1'7.1"	585 mm	1'11"
Blade Angle	—		25°		25°	

MODEL	D6R			
	6A		6A XL	
Gauge	1.88 m	74"	1.88 m	74"
Type	Angling		Angling	
Blade Capacities*	3.94 m <sup>3</sup>	5.15 yd <sup>3</sup>	3.94 m <sup>3</sup>	5.15 yd <sup>3</sup>
Weight, Shipping** (Dozer)	3195 kg	7044 lb	3195 kg	7044 lb
Tractor and Dozer Dimensions:				
A Length (Blade Straight)	5.00 m	17'1"	5.21 m	17'1"
Length (Blade Angled)	5.83 m	19'2"	6.05 m	19'10"
Width (Blade Angled)	3.77 m	12'5"	3.77 m	12'5"
Width (with C-Frame only)	2.99 m	9'10"	2.99 m	9'10"
Blade Dimensions:				
B Width (including std. end bits)	4.16 m	13'8"	4.16 m	13'8"
C Height	1154 mm	3'10"	1154 mm	3'10"
D Max. Digging Depth	511 mm	1'8"	511 mm	1'8"
E Ground Clearance @ Full Lift	1217 mm	4'0"	1217 mm	4'0"
F Manual Tilt	—		—	
H Max. Hydraulic Tilt	485 mm	1'4"	485 mm	1'4"
Blade Angle	25°		25°	
K Push Arm Trunnion Width (to Ball Centers)	2.58 m	8'6"	2.58 m	8'6"

\*Blade capacities as determined by SAE J1265. Tractor and dozer dimensions variations due to SystemOne undercarriage products are negligible.

Notice that the capacity of the SU-blade is the volume carried by a straight blade of the same dimensions plus the volume included in the "cup" of the SU-blade. It is intended for **relative comparisons of dozer sizes**, and not for predicting capacities or productivities in actual field conditions.

\*\*Shipping Weight — Total Bulldozer Arrangement includes: Blade, push arms or C-frame, braces, cylinders, lines, trunnions and lift cylinder mountings.

\*\*\*Meets Tier 4 Final/EU Stage IV/Japan 2014 (Tier 4 Final) emission standards.

MODEL	D6R2							
	6S		6SU		6SU XL		6S LGP	
Gauge	—		1880 mm	74"	1880 mm	74"	2286 mm	90"
Type	Straight		Semi-Universal		Semi-Universal		Straight	
Blade Capacities*	3.89 m <sup>3</sup>	5.1 yd <sup>3</sup>	5.61 m <sup>3</sup>	7.3 yd <sup>3</sup>	5.55 m <sup>3</sup>	7.26 yd <sup>3</sup>	3.75 m <sup>3</sup>	4.9 yd <sup>3</sup>
Weight, Shipping** (Dozer)	2251 kg	4963 lb	2333 kg	5143 lb	2570 kg	5666 lb	2418 kg	5331 lb
Tractor and Dozer Dimensions:								
A Length (Blade Straight)	4903 mm	193.1"	5095 mm	200.6"	5332 mm	210.0"	5465 mm	215.2"
Blade Dimensions:								
B Width (including std. end bits)	3360 mm	132.3"	3260 mm	128.3"	3260 mm	128.3"	4063 mm	160"
C Height	1257 mm	49.5"	1412 mm	55.6"	1412 mm	55.6"	1101 mm	43.3"
D Max. Digging Depth	473 mm	18.6"	473 mm	18.6"	459 mm	18.1"	655 mm	25.8"
E Ground Clearance @ Full Lift	1104 mm	43.5"	1104 mm	43.5"	1195 mm	47.0"	1083 mm	42.6"
G Max. Pitch Adjustment	+5.3 to 4.8°		+5.6 to -5.2°		+5.6 to -5.2°		+4.4 to -4.4°	
H Max. Hydraulic Tilt	765 mm	30.1"	743 mm	29.3"	743 mm	29.3"	701 mm	27.6"
K Push Arm Trunnion Width (to Ball Centers)	2640 mm	103.9"	2640 mm	103.9"	2640 mm	103.9"	3490 mm	137.4"

MODEL	D6R2				D6T			
	6A		6A XL		6A		6SU	
Gauge	1880 mm	74"	1880 mm	74"	1880 mm	74"	1880 mm	74"
Type	Angling		Angling		Angling		Semi-Universal	
Blade Capacities*	3.93 m <sup>3</sup>	5.1 yd <sup>3</sup>	3.89 m <sup>3</sup>	5.1 yd <sup>3</sup>	3.64 m <sup>3</sup>	4.75 yd <sup>3</sup>	5.35 m <sup>3</sup>	6.99 yd <sup>3</sup>
Weight, Shipping** (Dozer)	2715 kg	5986 lb	2625 kg	5787 lb	3138 kg	6904 lb	2973 kg	6540 lb
Tractor and Dozer Dimensions:								
A Length (Blade Straight)	5007 mm	197.2"	5209 mm	205.1"	5.00 m	16'5"	5.08 m	17'6"
Length (Blade Angled)	—		—		5.83 m	19'2"	—	
Width (Blade Angled)	—		—		3.78 m	12'5"	—	
Width (with C-Frame only)	—		—		2.93 m	9'8"	—	
Blade Dimensions:								
B Width (including std. end bits)	4166 mm	164.0"	4166 mm	164.0"	4.16 m	13'8"	3.26 m	10'8"
C Height	1155 mm	45.5"	1155 mm	45.5"	1154 mm	3'10"	1411 mm	4'8"
D Max. Digging Depth	506 mm	19.9"	524 mm	20.6"	506 mm	1'8"	453 mm	1'6"
E Ground Clearance @ Full Lift	1142 mm	45.0"	1205 mm	47.4"	1144 mm	3'9"	1204 mm	3'11"
G Max. Pitch Adjustment	25°		25°		—		+5.6° to -5.2°	
H Max. Hydraulic Tilt	408 mm	16.1"	408 mm	16.1"	519 mm	1'8"	811 mm	2'8"
Blade Angle	—		—		25°		—	
J Hydraulic Tilt (Manual Brace Centered)	—		—		—		455 mm	1'6"
K Push Arm Trunnion Width (to Ball Centers)	2640 mm	103.9"	2625 mm	103.9"	2.58 m	8'6"	2.58 m	8'6"

\*Blade capacities as determined by SAE J1265. Tractor and dozer dimensions variations due to SystemOne undercarriage products are negligible. Notice that the capacity of the SU-blade is the volume carried by a straight blade of the same dimensions plus the volume included in the "cup" of the SU-blade. It is intended for relative comparisons of dozer sizes, and not for predicting capacities or productivities in actual field conditions.

\*\*Shipping Weight — Total Bulldozer Arrangement includes: Blade, push arms or C-frame, braces, cylinders, lines, trunnions and lift cylinder mountings.

MODEL	D6T							
	6A XL		6SU XL		6VPAT XL		6A XW	
Gauge	1.88 m	74"	1.88 m	74"	2.13 m	84"	2.03 m	80"
Type	<b>Angling</b>		<b>Semi-Universal</b>		<b>VPAT</b>		<b>Angling</b>	
Blade Capacities*	3.94 m <sup>3</sup>	5.15 yd <sup>3</sup>	5.55 m <sup>3</sup>	7.26 yd <sup>3</sup>	4.64 m <sup>3</sup>	6.07 yd <sup>3</sup>	4.35 m <sup>3</sup>	5.69 yd <sup>3</sup>
Weight, Shipping** (Dozer)	3086 kg	6803 lb	2831 kg	6242 lb	3464 kg	7637 lb	3731 kg	8226 lb
Tractor and Dozer Dimensions:								
<b>A</b> Length (Blade Straight)	5.21 m	17'1"	5.33 m	17'6"	5.39 m	17'8"	5.29 m	17'4"
Length (Blade Angled)	6.05 m	19'10"	—	—	3.54 m	11'7"	6.20 m	20'4"
Width (Blade Angled)	3.77 m	12'5"	—	—	3.49 m	11'5"	4.11 m	13'6"
Width (with C-Frame only)	2.99 m	9'10"	—	—	—	—	3.29 m	10'10"
Blade Dimensions:								
<b>B</b> Width (including std. end bits)	4.16 m	13'8"	3.26 m	10'8"	3.88 m	12'9"	4.52 m	14'10"
<b>C</b> Height	1154 mm	3'10"	1407 mm	4'7"	1294 mm	4'3"	1153 mm	3'9"
<b>D</b> Max. Digging Depth	555 mm	1'10"	501 mm	1'7"	792 mm	2'7"	541 mm	1'9"
<b>E</b> Ground Clearance @ Full Lift	1112 mm	3'7"	1180 mm	3'10"	1053 mm	3'5"	1139 mm	3'9"
<b>G</b> Max. Pitch Adjustment	—	—	+4.0° to -4.0°	—	+0.5° to -3.1°	—	—	—
<b>H</b> Max. Hydraulic Tilt	424 mm	1'5"	811 mm	2'8"	410 mm	1'4"	424 mm	1'5"
Blade Angle	—	25°	—	—	—	24°	—	25°
<b>J</b> Hydraulic Tilt (Manual Brace Centered)	—	—	455 mm	1'6"	—	—	—	—
<b>K</b> Push Arm Trunnion Width (to Ball Centers)	2.58 m	8'6"	2.58 m	8'6"	—	—	2.89 m	9'8"

MODEL	D6T							
	6SU XW		6A LGP		6S LGP		6VPAT LGP/XW	
Gauge	2.03 m	80"	2.29 m	90"	2.29 m	90"	2.29 m	90"
Type	<b>Semi-Universal</b>		<b>Angling</b>		<b>Straight</b>		<b>VPAT</b>	
Blade Capacities*	5.64 m <sup>3</sup>	7.38 yd <sup>3</sup>	4.94 m <sup>3</sup>	6.46 yd <sup>3</sup>	3.79 m <sup>3</sup>	4.96 yd <sup>3</sup>	5.02 m <sup>3</sup>	6.57 yd <sup>3</sup>
Weight, Shipping** (Dozer)	2976 kg	6562 lb	3745 kg	8255 lb	2720 kg	5997 lb	3558 kg	7845 lb
Tractor and Dozer Dimensions:								
<b>A</b> Length (Blade Straight)	5.33 m	17'6"	5.81 m	19'1"	5.50 m	18'1"	5.53 m	18'2"
Length (Blade Angled)	—	—	6.81 m	22'4"	—	—	—	—
Width (Blade Angled)	—	—	4.63 m	15'2"	—	—	3.72 m	12'2"
Width (with C-Frame only)	—	—	3.77 m	12'5"	—	—	—	—
Blade Dimensions:								
<b>B</b> Width (including std. end bits)	3.56 m	11'8"	5.07 m	16'8"	4.06 m	13'3"	4.16 m	13'8"
<b>C</b> Height	1407 mm	4'7"	1150 mm	3'9"	1108 mm	3'8"	1294 mm	4'3"
<b>D</b> Max. Digging Depth	502 mm	1'7"	853 mm	2'10"	590 mm	1'11"	743 mm	2'5"
<b>E</b> Ground Clearance @ Full Lift	1180 mm	3'10"	1004 mm	3'3"	1094 mm	3'7"	1102 mm	3'7"
<b>G</b> Max. Pitch Adjustment	—	+4.0° to -4.0°	—	—	+4.4° to -4.4°	—	+0.5° to -3.1°	—
<b>H</b> Max. Hydraulic Tilt	791 mm	2'7"	618 mm	2'0"	747 mm	2'5"	435 mm	1'5"
Blade Angle	—	—	—	24.2°	—	—	—	24°
<b>J</b> Hydraulic Tilt (Manual Brace Centered)	442 mm	1'5"	—	—	399 mm	1'4"	—	—
<b>K</b> Push Arm Trunnion Width (to Ball Centers)	2.89 m	9'8"	3.42 m	11'5"	3.42 m	11'5"	—	—

\*Blade capacities as determined by SAE J1265.

Notice that the capacity of the SU-blade is the volume carried by a straight blade of the same dimensions plus the volume included in the "cup" of the SU-blade. It is intended for **relative comparisons of dozer sizes**, and not for predicting capacities or productivities in actual field conditions.

\*\*Shipping Weight — Total Bulldozer Arrangement includes: Blade, push arms or C-frame, braces, cylinders, lines, trunnions and lift cylinder mountings.

MODEL	D7E							
	7A		7S		7SU		7U	
Type	Angling		Straight		Semi-Universal		Universal	
Blade Capacities*	5.9 m <sup>3</sup>	7.7 yd <sup>3</sup>	6.0 m <sup>3</sup>	7.8 yd <sup>3</sup>	6.6 m <sup>3</sup>	8.7 yd <sup>3</sup>	8.1 m <sup>3</sup>	10.6 yd <sup>3</sup>
Weight, Shipping** (Dozer)	3945 kg	8697 lb	3718 kg	8196 lb	3778 kg	8329 lb	4020 kg	8862 lb
Tractor and Dozer Dimensions:								
A Length (Blade Straight)	6.20 m	20'4"	5.92 m	19'5"	6.17 m	20'3"	6.38 m	20'11"
Length (Blade Angled)	7.07 m	23'2"	—	—	—	—	—	—
Width (Blade Angled)	4.12 m	13'6"	—	—	—	—	—	—
Width (with C-Frame only)	3.40 m	11'2"	—	—	—	—	—	—
Blade Dimensions:								
B Width (including std. end bits)	4.50 m	14'9"	3.90 m	12'10"	3.71 m	12'2"	4.02 m	13'2"
C Height	1423 mm	4'8"	1522 mm	5'0"	1524 mm	5'0"	1550 mm	5'1"
D Max. Digging Depth	715 mm	2'4"	555 mm	1'10"	555 mm	1'10"	555 mm	1'10"
E Ground Clearance @ Full Lift	1159 mm	3'10"	1159 mm	3'10"	1159 mm	3'10"	1159 mm	3'10"
G Max. Pitch Adjustment	—	—	52° to 58°		52° to 58°		52° to 58°	
Blade Angle (either side)	25°		—		—		—	
H Max. Hydraulic Tilt	631 mm	2'1"	590 mm	1'11"	551 mm	1'10"	601 mm	2'0"
J Hydraulic Tilt (Manual Brace Centered)	—	—	530 mm	1'9"	500 mm	1'8"	550 mm	1'10"
K Push Arm Trunnion Width (to Ball Centers)	2.81 m	9'2"	2.81 m	9'2"	2.81 m	9'2"	2.81 m	9'2"

MODEL	D7E		D7R/D7R XR			D7R LGP		
	7S LGP		7SU		7A		7S	
Type	Straight		Semi-Universal		Angling		Straight	
Blade Capacities*	6.1 m <sup>3</sup>	7.9 yd <sup>3</sup>	6.86 m <sup>3</sup>	8.98 yd <sup>3</sup>	3.89 m <sup>3</sup>	5.07 yd <sup>3</sup>	5.89 m <sup>3</sup>	7.7 yd <sup>3</sup>
Weight, Shipping** (Dozer)	3855 kg	8498 lb	3593 kg	7904 lb	3523 kg	7751 lb	3732 kg	8229 lb
Tractor and Dozer Dimensions:								
A Length (Blade Straight)	6.28 m	20'7"	6.03 m	19'9"	4218 mm	13'10"	5.81 m	19'1"
Length (Blade Angled)	—	—	—	—	5098 mm	16'9"	—	—
Width (Blade Angled)	—	—	—	—	4114 mm	13'6"	—	—
Width (with C-Frame only)	—	—	—	—	3073 mm	10'1"	—	—
Blade Dimensions:								
B Width (including std. end bits)	4.59 m	15'1"	3.69 m	12'1"	4503 mm	14'9"	4.50 m	14'9"
C Height	1351 mm	4'5"	1524 mm	5'0"	1111 mm	3'8"	1343 mm	4'4.9"
D Max. Digging Depth	631 mm	2'1"	527 mm	1'8.7"	647 mm	2'1"	668 mm	2'2.3"
E Ground Clearance @ Full Lift	1292 mm	4'3"	1145 mm	3'9.1"	1340 mm	4'5"	1153 mm	3'9.4"
G Max. Pitch Adjustment	54° to 60°		+3.1° to 3.9°		—		+3.0° to 3.9°	
Blade Angle (either side)	778 mm	2'7"	—	—	25°		—	
H Max. Hydraulic Tilt	468 mm	1'7"	799 mm	2'7.4"	466 mm	1'6"	686 mm	2'3"
J Hydraulic Tilt (Manual Brace Centered)	3.35 m	11'0"	474 mm	18.6"	627 mm	2'1"	426 mm	16.8"
K Push Arm Trunnion Width (to Ball Centers)	—	—	2.87 m	9'5"	2795 mm	9'2"	3.37 m	11'1"

\*Blade capacities as determined by SAE J1265.

Notice that the capacity of the U-blade is the volume carried by a straight blade of the same dimensions plus the volume included in the "cup" of the U-blade. It is intended for **relative comparisons of dozer sizes**, and not for predicting capacities or productivities in actual field conditions.

Notice that the capacity of the SU-blade is the volume carried by a straight blade of the same dimensions plus the volume included in the "cup" of the SU-blade. It is intended for **relative comparisons of dozer sizes**, and not for predicting capacities or productivities in actual field conditions.

\*\*Shipping Weight — Total Bulldozer Arrangement includes: Blade, push arms or C-frame, braces, cylinders, lines, trunnions and lift cylinder mountings.

MODEL	D8R/D8T							
	8A		8SU		8U		8SU LGP	
Type	Angling		Semi-U		Universal		Semi-U	
Blade Capacities*	5.2 m <sup>3</sup>	<b>6.8 yd<sup>3</sup></b>	8.6 m <sup>3</sup>	<b>11.3 yd<sup>3</sup></b>	11.8 m <sup>3</sup>	<b>15.4 yd<sup>3</sup></b>	9.9 m <sup>3</sup>	<b>12.9 yd<sup>3</sup></b>
Weight, Shipping** (Dozer)	5121 kg	<b>11,289 lb</b>	4260 kg	<b>9392 lb</b>	4895 kg	<b>10,793 lb</b>	4703 kg	<b>10,368 lb</b>
Tractor and Dozer Dimensions:								
<b>A</b> Length (Blade Straight)	6.57 m	<b>21'7"</b>	6.39 m	<b>21'0"</b>	6.79 m	<b>22'3"</b>	6281 mm	<b>20'7"</b>
Length (Blade Angled)	7.62 m	<b>25'0"</b>	—	—	—	—	—	—
Width (Blade Angled)	4.52 m	<b>14'10"</b>	—	—	—	—	—	—
Width (with C-Frame only)	3.38 m	<b>11'1"</b>	—	—	—	—	—	—
Blade Dimensions:								
<b>B</b> Width (including std. end bits)	5.00 m	<b>16'5"</b>	3.93 m	<b>12'11"</b>	4.25 m	<b>13'11"</b>	4.53 m	<b>14'10"</b>
<b>C</b> Height	1174 mm	<b>3'10"</b>	1690 mm	<b>5'7"</b>	1740 mm	<b>5'9"</b>	1622 mm	<b>5'4"</b>
<b>D</b> Max. Digging Depth	625 mm	<b>2'1"</b>	511 mm	<b>20.1"</b>	567 mm	<b>1'10"</b>	513 mm	<b>1'9"</b>
<b>E</b> Ground Clearance @ Full Lift	1323 mm	<b>4'3"</b>	1310 mm	<b>4'4"</b>	1239 mm	<b>4'1"</b>	1308 mm	<b>4'3.5"</b>
<b>G</b> Max. Pitch Adjustment	—	—	<b>+3.0° to 2.9°</b>		<b>+3.0° to 2.9°</b>		—	—
Blade Angle (either side)	<b>25°</b>		—	—	—	—	—	—
<b>H</b> Max. Hydraulic Tilt	733 mm	<b>2'5"</b>	861 mm	<b>2'10"</b>	996 mm	<b>3'3"</b>	908 mm	<b>3'0"</b>
<b>J</b> Hydraulic Tilt	—		—		—		—	
(Manual Brace Centered)	—	—	585 mm	<b>1'11"</b>	635 mm	<b>2'1"</b>	—	—
<b>K</b> Push Arm Trunnion Width	—		—		—		—	
(to Ball Centers)	2983 mm	<b>9'9"</b>	2983 mm	<b>9'9"</b>	2983 mm	<b>9'9"</b>	3329 mm	<b>10'11"</b>
Maximum Track Width Permitted	710 mm	<b>2'4"</b>	710 mm	<b>2'4"</b>	710 mm	<b>2'4"</b>	965 mm	<b>3'2"</b>
Dual Tilt Option								
<b>G</b> Dual Pitch Adj.	—	—	<b>±4.6°</b>		<b>±4.6°</b>		—	—
<b>H</b> Dual Max. Hyd. Tilt	—	—	879 mm	<b>2'11"</b>	950 mm	<b>3'1"</b>	—	—

\*Blade capacities as determined by SAE J1265.

Notice that the capacity of the U-blade is the volume carried by a straight blade of the same dimensions plus the volume included in the "cup" of the U-blade. It is intended for **relative comparisons of dozer sizes**, and not for predicting capacities or productivities in actual field conditions.

Notice that the capacity of the SU-blade is the volume carried by a straight blade of the same dimensions plus the volume included in the "cup" of the SU-blade. It is intended for **relative comparisons of dozer sizes**, and not for predicting capacities or productivities in actual field conditions.

\*\*Shipping Weight — Total Bulldozer Arrangement includes: Blade, push arms or C-frame, braces, cylinders, lines, trunnions and lift cylinder mountings.

MODEL	D9R/D9T			
	9SU		9U	
Type	Semi-U		Universal	
Blade Capacities*	13.5 m <sup>3</sup>	17.7 yd <sup>3</sup>	16.4 m <sup>3</sup>	21.4 yd <sup>3</sup>
Weight, Shipping** (Dozer)	6863 kg	15,130 lb	7388 kg	16,288 lb
Tractor and Dozer Dimensions:				
<b>A</b> Length (Blade Straight)	6.60 m	21'6"	6.96 m	22'8"
Blade Dimensions:				
<b>B</b> Width (including std. end bits)	4.31 m	14'1"	4.65 m	15'2"
<b>C</b> Height	1934 mm	6'4.1"	1934 mm	6'4.1"
<b>D</b> Max. Digging Depth	606 mm	1'11.9"	606 mm	1'11.9"
<b>E</b> Ground Clearance @ Full Lift	1422 mm	4'8"	1422 mm	4'8"
<b>G</b> Max. Pitch Adjustment	+3.4° to 2.9°		+3.4° to 2.9°	
<b>H</b> Max. Hydraulic Tilt	940 mm	3'1"	1014 mm	3'3.9"
<b>J</b> Hydraulic Tilt (Manual Brace Centered)	570 mm	1'10.4"	616 mm	2'0.3"
<b>K</b> Push Arm Trunnion Width (to Ball Centers)	3.30 m	10'8"	3.30 m	10'8"
Maximum Track Width Permitted	762 mm	2'6"	762 mm	2'6"
Dual Tilt Option				
<b>G</b> Dual Pitch Adj.	+4.8° to 5.2°		+4.8° to 4.9°	
<b>H</b> Dual Max. Hyd. Tilt	1139 mm	3'8.8"	1231 mm	4'0.5"

\*Blade capacities as determined by SAE J1265.

Notice that the capacity of the U-blade is the volume carried by a straight blade of the same dimensions plus the volume included in the "cup" of the U-blade. It is intended for **relative comparisons of dozer sizes**, and not for predicting capacities or productivities in actual field conditions.

Notice that the capacity of the SU-blade is the volume carried by a straight blade of the same dimensions plus the volume included in the "cup" of the SU-blade. It is intended for **relative comparisons of dozer sizes**, and not for predicting capacities or productivities in actual field conditions.

\*\*Shipping Weight — Total Bulldozer Arrangement includes: Blade, push arms or C-frame, braces, cylinders, lines, trunnions and lift cylinder mountings.

MODEL	D10T2			
	10SU		10U	
Type	Semi-U		Universal	
Blade Capacities*	18.5 m <sup>3</sup>	24.2 yd <sup>3</sup>	22.0 m <sup>3</sup>	28.7 yd <sup>3</sup>
Weight, Shipping**				
Standard Dozer	10 229 kg	22,550 lb	10 784 kg	23,775 lb
Abrasion Dozer	11 069 kg	24,403 lb	12 413 kg	27,366 lb
Tractor and Dozer Dimensions:				
<b>A</b> Length	7.37 m	24'2"	7.73 m	25'4"
Width	4.86 m	15'11"	5.26 m	17'3"
Blade Dimensions:				
<b>B</b> Width (including std. end bits)	4.94 m	16'3"	5.26 m	17'3"
<b>C</b> Height	2.12 m	6'11"	2.12 m	6'11"
<b>D</b> Max. Digging Depth	674 mm	2'2.5"	674 mm	2'2.5"
<b>E</b> Ground Clearance @ Full Lift	1497 mm	4'10.9"	1497 mm	4'10.9"
<b>G</b> Max. Pitch Adjustment		+1.7° to 2.3°		+1.7° to 2.3°
<b>H</b> Max. Hydraulic Tilt	993 mm	3'3.1"	1074 mm	3'6.3"
<b>J</b> Hydraulic Tilt (Manual Brace Centered)	722 mm	2'4.4"	782 mm	2'6.8"
<b>K</b> Push Arm Trunnion Width (to Ball Centers)	3.60 m	11'10"	3.60 m	11'10"
Maximum Track Width Permitted	762 mm	2'6"	762 mm	2'6"
Dual Tilt Option				
<b>G</b> Dual Pitch Adjustment		+5.2° to 5.5°		+5.2° to 5.5°
<b>H</b> Dual Max. Hyd. Tilt	1441 mm	4'8.7"	1560 mm	5'1.4"

\*Blade capacities as determined by SAE J1265.

Notice that the capacity of the U-blade is the volume carried by a straight blade of the same dimensions plus the volume included in the "cup" of the U-blade. It is intended for **relative comparisons of dozer sizes**, and not for predicting capacities or productivities in actual field conditions.

Notice that the capacity of the SU-blade is the volume carried by a straight blade of the same dimensions plus the volume included in the "cup" of the SU-blade. It is intended for **relative comparisons of dozer sizes**, and not for predicting capacities or productivities in actual field conditions.

\*\*Shipping Weight — Total Bulldozer Arrangement includes: Blade, push arms or C-frame, braces, cylinders, lines, trunnions and lift cylinder mountings.

All dimensions are approximate.

MODEL	D11T					
	11SU		11U		11 CD	
Type	Semi-U		Universal		CarryDozer	
Blade Capacities*	27.2 m <sup>3</sup>	35.5 yd <sup>3</sup>	34.4 m <sup>3</sup>	45.0 yd <sup>3</sup>	43.6 m <sup>3</sup>	57.0 yd <sup>3</sup>
Weight, Shipping**						
Standard Dozer	14 813 kg	32,658 lb	17 296 kg	38,131 lb	24 085 kg	53,099 lb
Abrasion Dozer	16 192 kg	35,698 lb	18 823 kg	41,498 lb	—	—
Tractor and Dozer Dimensions:						
A Length	8.58 m	28'2"	8.64 m	28'4"	8.77 m	28'9"
Width	5.50 m	18'1"	6.26 m	20'7"	6.43 m	21'1"
Blade Dimensions:						
B Width (including std. end bits)	5.58 m	18'4"	6.35 m	20'10"	6.71 m	22'0"
C Height	2.75 m	9'0"	2.83 m	9'3"	2.96 m***	9'8"***
D Max. Digging Depth	766 mm	2'6.2"	766 mm	2'6.2"	688 mm	2'3"
E Ground Clearance @ Full Lift	1533 mm	5'0.4"	1533 mm	5'0.4"	1850 mm	6'1"
G Max. Pitch Adjustment	+2.1° to 2.2°		+2.1° to 2.2°		—	
H Max. Hydraulic Tilt	1184 mm	3'10.6"	1344 mm	4'4.9"	1800 mm	5'11"
J Hydraulic Tilt (Manual Brace Centered)	886 mm	2'10.9"	1006 mm	3'3.6"	—	
K Push Arm Trunnion Width (to Ball Centers)	4.18 m	13'9"	4.18 m	13'9"	4.18 m	13'9"
Maximum Track Width Permitted	914 mm	3'0"	914 mm	3'0"	914 mm	3'0"
Dual Tilt Option	+7.5° to 7.6° or +0° to 13°		+7.5° to 7.6° or +0° to 13°		+47.8° to 10.4°	
G Dual Pitch Adjustment	+0° to 13°		+0° to 13°		+47.8° to 10.4°	
H Dual Max. Hyd. Tilt	1706 mm	5'7.2"	1938 mm	6'4.3"	—	

\*Blade capacities as determined by SAE J1265.

Notice that the capacity of the U-blade is the volume carried by a straight blade of the same dimensions plus the volume included in the "cup" of the U-blade. It is intended for **relative comparisons of dozer sizes**, and not for predicting capacities or productivities in actual field conditions.

Notice that the capacity of the SU-blade is the volume carried by a straight blade of the same dimensions plus the volume included in the "cup" of the SU-blade. It is intended for **relative comparisons of dozer sizes**, and not for predicting capacities or productivities in actual field conditions.

\*\*Shipping Weight — Total Bulldozer Arrangement includes: Blade, push arms or C-frame, braces, cylinders, lines, trunnions and lift cylinder mountings.

\*\*\*Blade height with cutting edge at 53°.

All dimensions are approximate.



**BULLDOZER PRODUCTION OFF-THE-JOB**

You can estimate bulldozer production using the production curves that follow and the correction factors that are applicable. Use this formula:

$$\text{Production (Lm}^3\text{/hr)} = \frac{\text{Maximum production}}{\text{LCY/hr}} \times \frac{\text{Correction factors}}{\text{LCY/hr}}$$

The bulldozer production curves give maximum uncorrected production for universal, semi-universal, and straight blades and are based on the following conditions:

1. 100% efficiency (60 minute hour — level cycle).
2. Power shift machines with 0.05 min. fixed times.
3. Machine cuts for 15 m (50 feet), then drifts blade load to dump over a high wall. (Dump time — 0 sec.)
4. Soil density of 1370 kg/Lm<sup>3</sup> (2300 lb/LCY).
5. Coefficient of traction:\*
  - a. Track machines — 0.5 or better
  - b. Wheel machines — 0.4 or better
6. Hydraulic controlled blades used.
7. Dig 1F\*\*  
Carry 2F\*\*  
Return 2R\*\*

To obtain estimated production in bank cubic meters or bank cubic yards, appropriate load factor from the Tables section should be applied to the corrected production as calculated above.

$$\text{Production Bm}^3\text{/hr} = \frac{\text{Lm}^3\text{/hr}}{\text{(BCY/h)}} \times \frac{\text{LF}}{\text{LCY/h}} \times \text{LF}$$

\*Coefficient of traction assumed to be at least 0.4. While poor traction affects both track and wheel vehicles, causing them to take smaller blade loads, wheeled units are affected more severely and production falls much more rapidly. While no fixed rules can predict this production loss, a rough rule of thumb is that wheel dozer production falls off 4% for each one-hundredth decrease in coefficient of traction below 0.40. If, for example, coefficient of traction is 0.30, the difference is ten-hundredths (0.10), and production is 60% (10 × 4% = 40% decrease).

\*\*This gear sequence is based on level to downhill terrain, light to medium density material, and no blade extensions such as spill plates, rock guards, etc. Exceeding these conditions may require carry in 1F, but productivity should equal or exceed “standard conditions” due to the larger loads that can be carried in 1F.

ESTIMATED DOZING PRODUCTION • Universal Blades • D7E through D11T CD

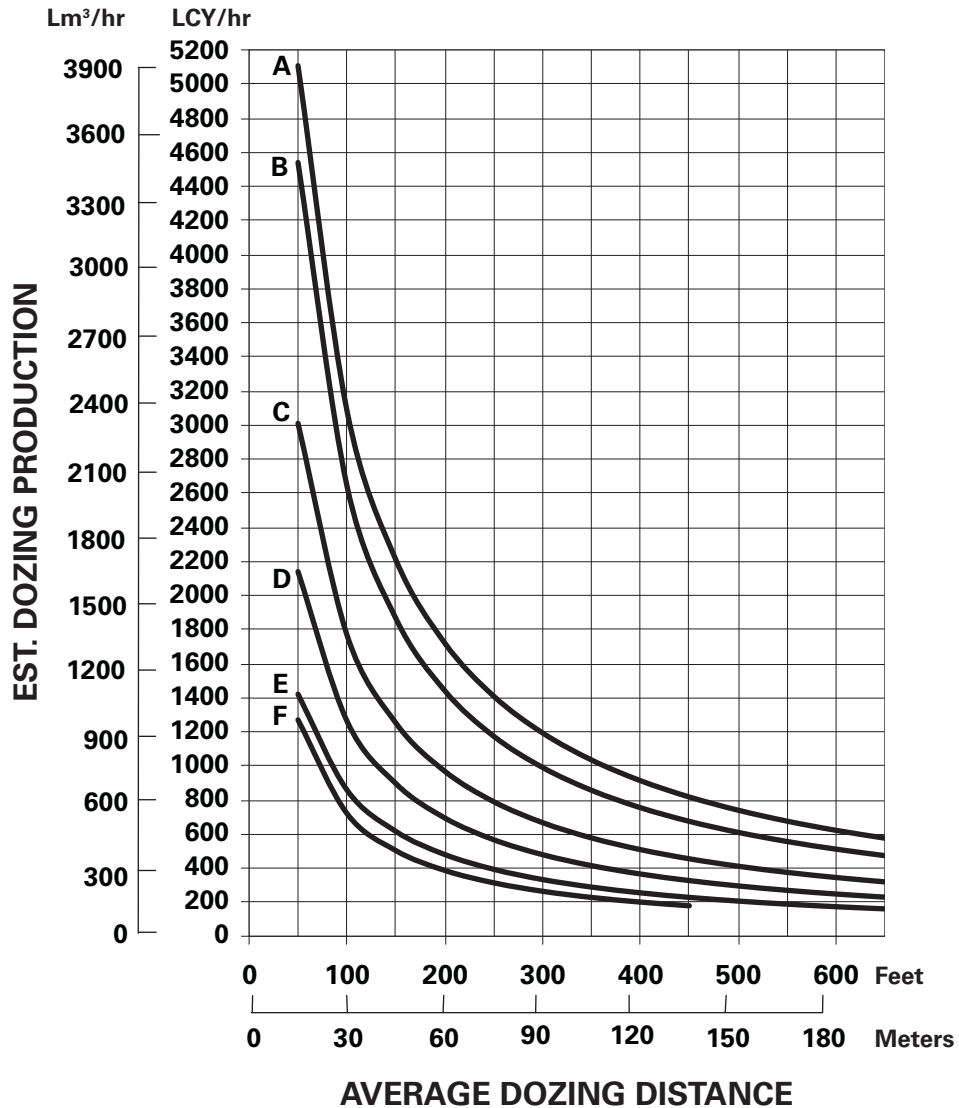

KEY

- A — D11T CD
- B — D11T
- C — D10T2
- D — D9T
- E — D8T
- F — D7E

**NOTE:** This chart is based on numerous field studies made under varying job conditions. Refer to correction factors following these charts.

**ESTIMATED DOZING PRODUCTION ● Semi-Universal Blades ● D7E through D11T**

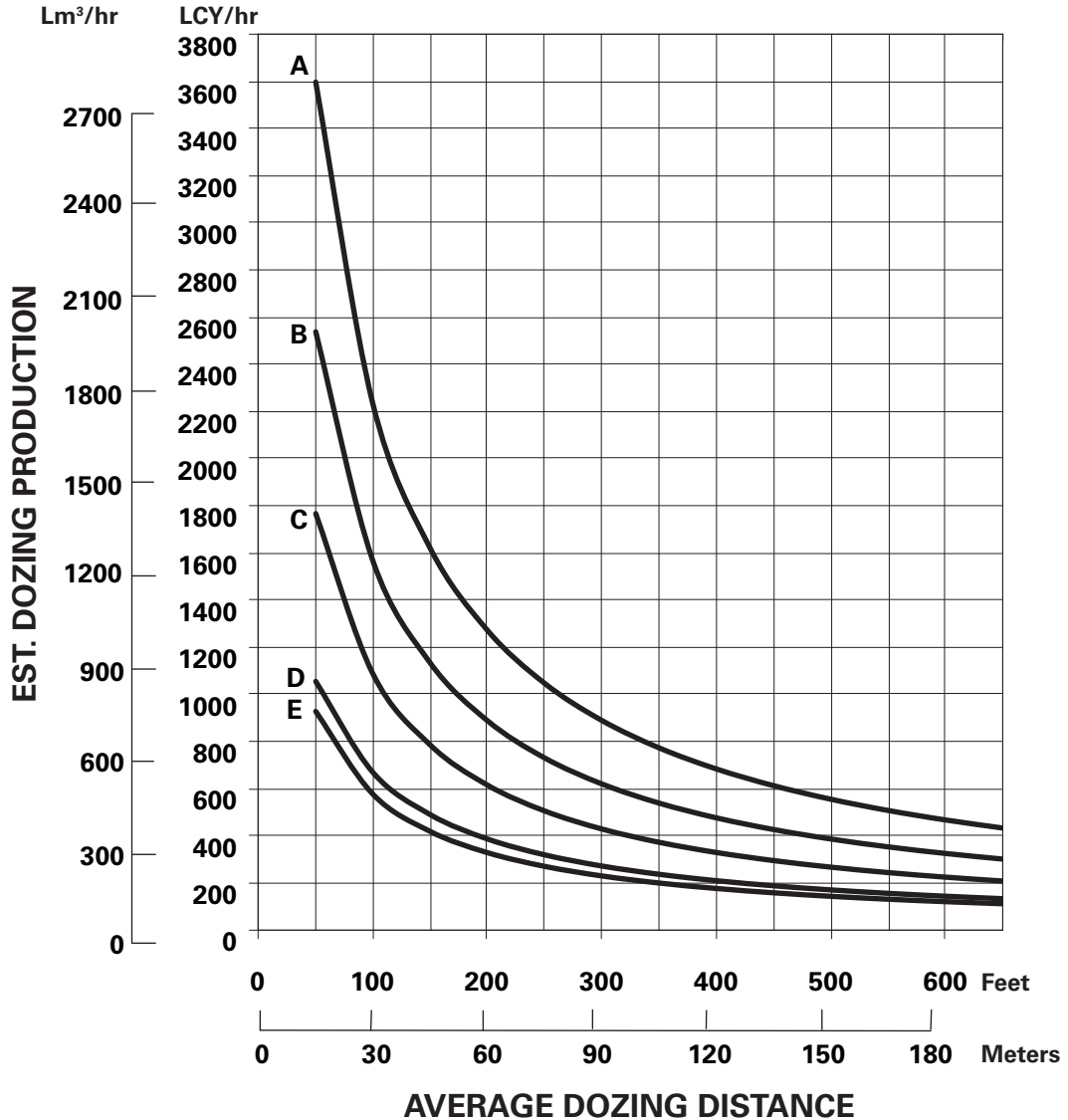

**KEY**

- A — D11T
- B — D10T2
- C — D9T
- D — D8T
- E — D7E

**NOTE:** This chart is based on numerous field studies made under varying job conditions. Refer to correction factors following these charts.

**ESTIMATED DOZING PRODUCTION • Semi-Universal Blades • D6N through D8R**

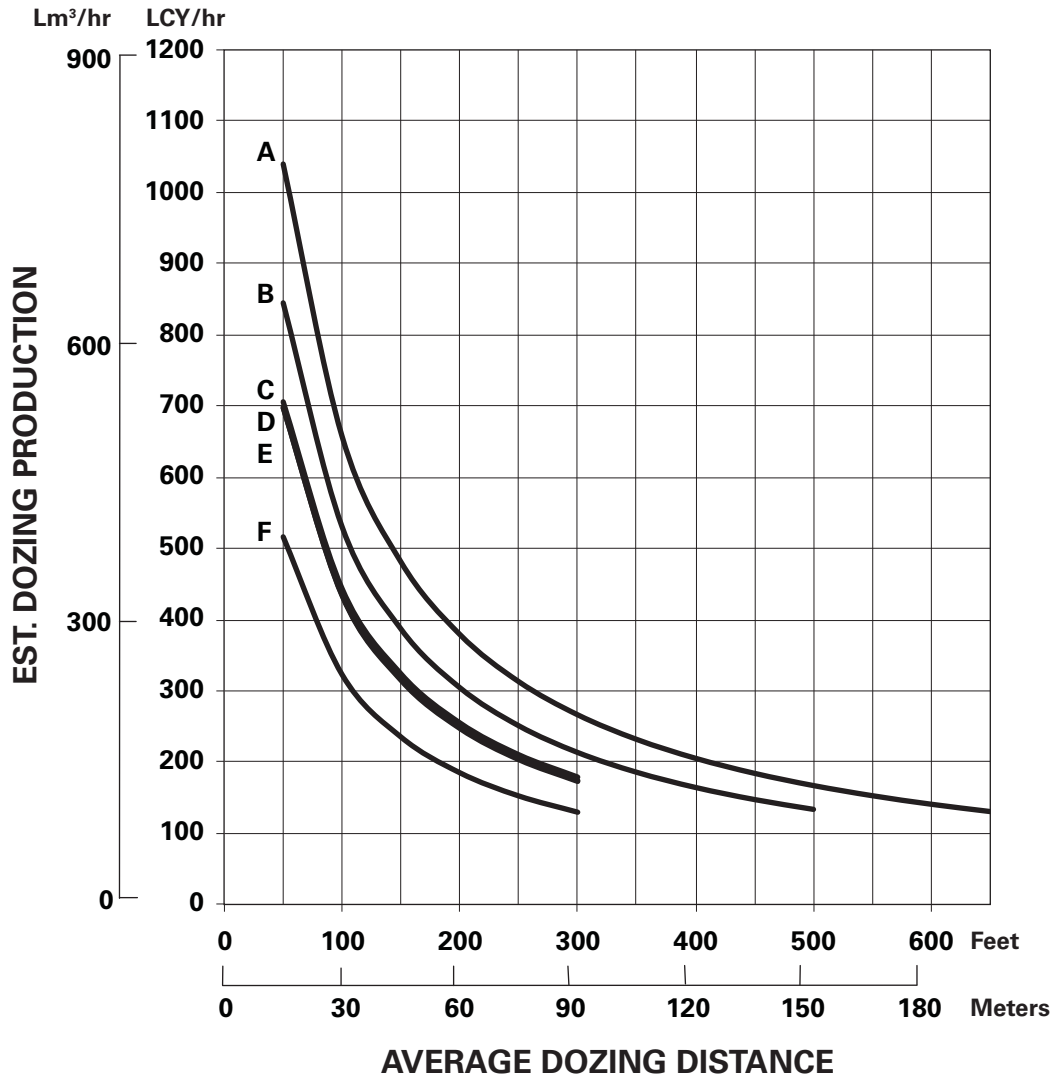

**KEY**

- A — D8R
- B — D7R
- C — D6T Tier 4 Interim/Stage IIIB/Japan 2011 (Tier 4 Interim)
- D — D6T
- E — D6R
- F — D6N

**NOTE:** This chart is based on numerous field studies made under varying job conditions. Refer to correction factors following these charts.

**ESTIMATED DOZING PRODUCTION ● Straight Blades ● D6T through D7E**

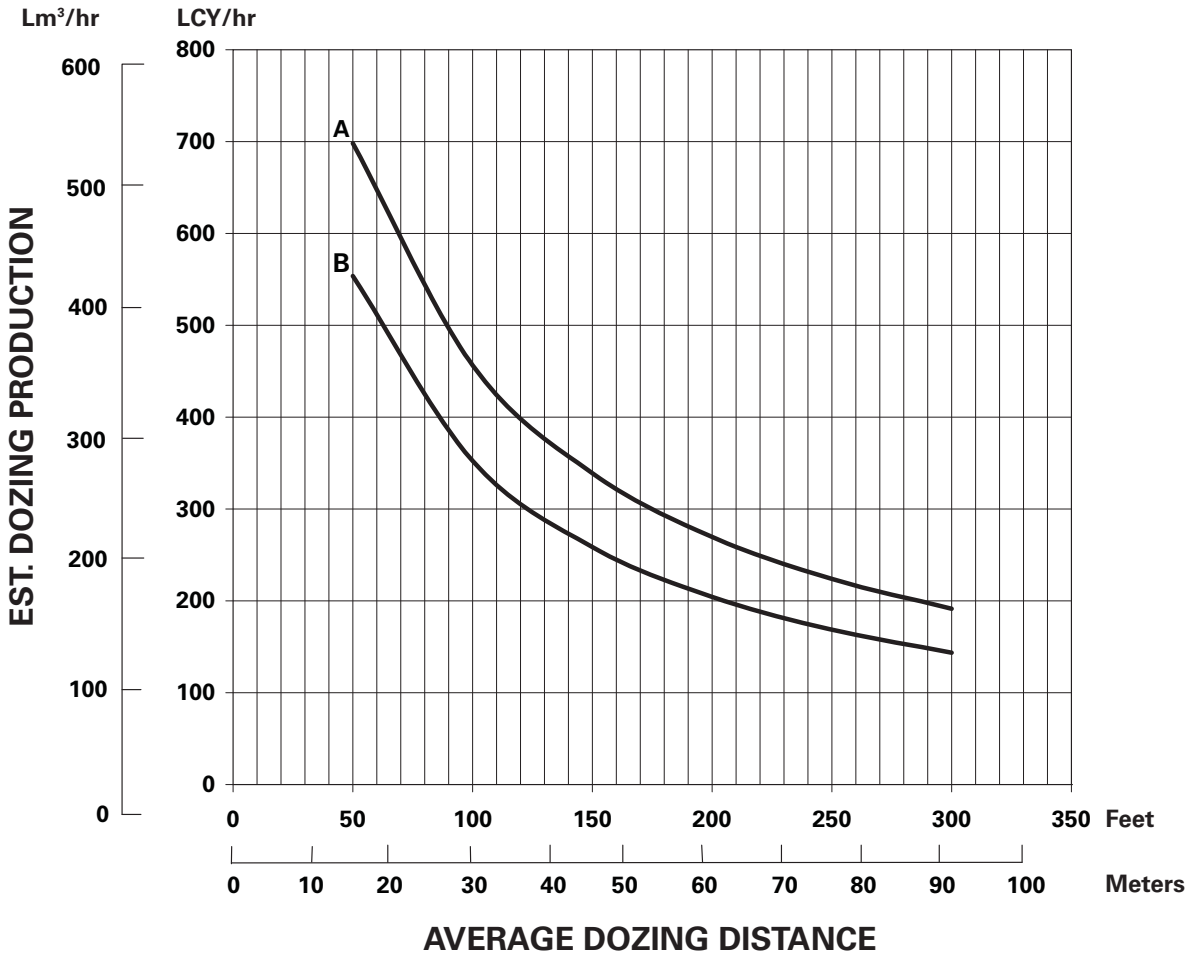

**KEY**

A — D7E

B — D6T

**NOTE:** This chart is based on numerous field studies made under varying job conditions. Refer to correction factors following these charts.

**JOB CONDITION CORRECTION FACTORS**

	TRACK-TYPE TRACTOR
<b>OPERATOR —</b>	
Excellent	1.00
Average	0.75
Poor	0.60
<b>MATERIAL —</b>	
Loose stockpile	1.20
Hard to cut; frozen —	
with tilt cylinder	0.80
without tilt cylinder	0.70
Hard to drift; “dead” (dry, non-cohesive material) or very sticky material	0.80
Rock, ripped or blasted	0.60-0.80
<b>SLOT DOZING</b>	
	1.20
<b>SIDE BY SIDE DOZING</b>	
	1.15-1.25
<b>VISIBILITY —</b>	
Dust, rain, snow, fog or darkness	0.80
<b>JOB EFFICIENCY —</b>	
50 min/hr	0.83
40 min/hr	0.67
<b>BULLDOZER*</b>	
Adjust based on SAE capacity relative to the base blade used in the Estimated Dozing Production graphs.	
<b>GRADES —</b> See following graph.	

\*NOTE: Angling blades and cushion blades are not considered production dozing tools. Depending on job conditions, the A-blade and C-blade will average 50-75% of straight blade production.

**% Grade vs. Dozing Factor**

(-) Downhill  
 (+) Uphill

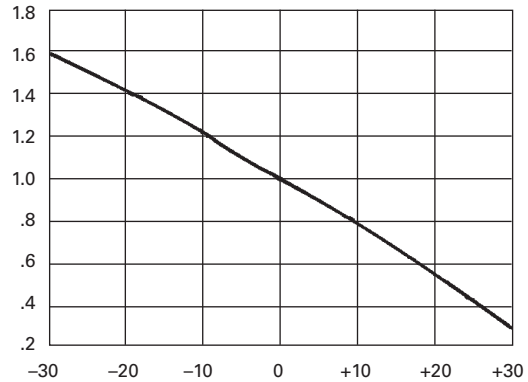

**ESTIMATING DOZER PRODUCTION OFF-THE-JOB**

*Example problem:*

Determine average hourly production of a D8T/8SU (with tilt cylinder) moving hard-packed clay an average distance of 45 m (150 feet) down a 15% grade, using a slot dozing technique.

Estimated material weight is 1600 kg/Lm<sup>3</sup> (2650 lb/LCY). Operator is average. Job efficiency is estimated at 50 min/hr.

Uncorrected Maximum Production — 458 Lm<sup>3</sup>/h (600 LCY/hr) (example only)

Applicable Correction Factors:

- Hard-packed clay is “hard to cut” material . . . -0.80
- Grade correction (from graph) . . . . . -1.30
- Slot dozing . . . . . -1.20
- Average operator . . . . . -0.75
- Job efficiency (50 min/hr) . . . . . -0.83
- Weight correction. . . . . (2300/2650) -0.87

$$\begin{aligned}
 \text{Production} &= \text{Maximum Production} \times \text{Correction Factors} \\
 &= (600 \text{ LCY/hr}) (0.80) (1.30) (1.20) (0.75) \\
 &\quad (0.83) (0.87) \\
 &= 405.5 \text{ LCY/hr}
 \end{aligned}$$

To obtain production in metric units, the same procedure is used substituting maximum uncorrected production in Lm<sup>3</sup>.

$$\begin{aligned}
 &= 458 \text{ Lm}^3/\text{h} \times \text{Factors} \\
 &= 309.6 \text{ Lm}^3/\text{h}
 \end{aligned}$$

**MEASURING PRODUCTION ON-THE-JOB**

Three generally accepted methods of measuring bulldozer production are listed below. The third method is empirical, but is the simplest to conduct.

1. Employing Surveying Techniques
  - a. Conduct time study and then cross-section the cut to determine the volume of material removed. (Production in  $Bm^3$  or BCY per unit of time)
  - b. Conduct time study and then cross-section the fill to determine the volume of fill material. (Production in  $Lm^3$  or LCY per unit of time)
2. Weighing Blade Loads
 

Conduct time study and weigh material moved by bulldozer by weighing the loader bucket loads.
3. Measuring Blade Loads
  - a. Dozer operation
    - (1) Pick up and carry load onto a level area and stop.
    - (2) Raise the blade directly over the pile pulling forward slightly as blade comes up, leaving a nearly symmetrical pile.
    - (3) Reverse to clear the pile.
  - b. Measurements
    - (1) The average *height* (H) of the pile in feet. Hold the tape vertically at the inside edge of each grouser mark. Sight along top of the pile to obtain the correct measurement.

**TOP VIEW**

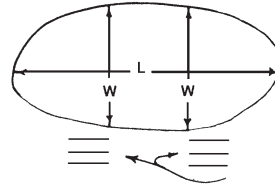

**SIDE VIEW**

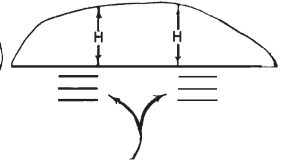

**GROUSER MARKS**

- (2) The average *width* (W) of the pile in feet. Hold the tape horizontally over the pile and sight at the inside edge of each grouser mark and the corresponding opposite side of the pile.
- (3) The greatest *length* (L) of the pile in feet. Hold the tape horizontally over the pile and sight at each end of the pile.
- c. With the above measurements, now compute the blade load.
  - (1) Average the height measurement (H)
  - (2) Average the width measurement (W)
  - (3) Load ( $Lm^3$  or LCY) =  $0.0138 \times (HWL)$
  - (4) Load ( $Bm^3$  or BCY) =  $Lm^3$  or LCY  $\times$  LF
- d. Combine the calculated blade load with time study to figure production.

**ATTACHMENTS**

**VARIABLE RADIUS (VR)  
SEMI-U BLADES**

	<b>D6T</b>		<b>D7R</b>		<b>D8R/D8T</b>	
Capacity	5.81 m <sup>3</sup>	<b>7.6 yd<sup>3</sup></b>	7.84 m <sup>3</sup>	<b>10.25 yd<sup>3</sup></b>	11.28 m <sup>3</sup>	<b>14.75 yd<sup>3</sup></b>
Width	3349 mm	<b>11'0"</b>	3912 mm	<b>12'10"</b>	4369 mm	<b>14'4"</b>
Height	1473 mm	<b>4'10"</b>	1626 mm	<b>5'4"</b>	1778 mm	<b>5'10"</b>
Weight	1360 kg	<b>3000 lb</b>	2000 kg	<b>4400 lb</b>	3010 kg	<b>6640 lb</b>

**LANDFILL BLADES**

	<b>D6T</b>		<b>D7E</b>		<b>D7R</b>	
Capacity	12.5 m <sup>3</sup>	<b>16.4 yd<sup>3</sup></b>	14 m <sup>3</sup>	<b>18.4 yd<sup>3</sup></b>	18.1 m <sup>3</sup>	<b>23.7 yd<sup>3</sup></b>
Width	3886 mm	<b>12'9"</b>	3713 mm	<b>12'2"</b>	4267 mm	<b>14'0"</b>
Height	1796 mm	<b>5'10.7"</b>	1524 mm	<b>5'0"</b>	2083 mm	<b>6'10"</b>
Weight	1450 kg	<b>3200 lb</b>	4380 kg	<b>9636 lb</b>	2608 kg	<b>5750 lb</b>

**LANDFILL BLADES**

	<b>D8R/D8T</b>		<b>D9R/D9T</b>	
Capacity	24.4 m <sup>3</sup>	<b>32 yd<sup>3</sup></b>	38.5 m <sup>3</sup>	<b>50.3 yd<sup>3</sup></b>
Width	4928 mm	<b>16'2"</b>	5442 mm	<b>17'10"</b>
Height	2286 mm	<b>7'6"</b>	2178 mm	<b>7'1.75"</b>
Weight	3175 kg	<b>7000 lb</b>	4900 kg	<b>10,800 lb</b>

This list is not all inclusive. Contact your Cat dealer for special attachment needs.

- Special Attachments
- Coal U-Blades
  - Woodchip Dozers
  - Reclamation U-Blades
  - Cushion Dozers

COAL U-BLADES	D6T		D7E		D7E LGP	
Capacity	9.7 m <sup>3</sup>	<b>12.63 yd<sup>3</sup></b>	14.8 m <sup>2</sup>	<b>19.4 yd<sup>2</sup></b>	14.8 m <sup>2</sup>	<b>19.4 yd<sup>2</sup></b>
Width	4267 mm	<b>14'0"</b>	4902 mm	<b>193"</b>	4902 mm	<b>193"</b>
Height	1473 mm	<b>4'10"</b>	1778 mm	<b>70"</b>	1778 mm	<b>70"</b>
Weight	1452 kg	<b>3200 lb</b>	2420 kg	<b>5335 lb</b>	2592 kg	<b>5714 lb</b>

COAL U-BLADES	D8R/D8T		D9R/D9T		D10T2		D11T	
Capacity	21.4 m <sup>3</sup>	<b>28 yd<sup>3</sup></b>	37 m <sup>3</sup>	<b>48 yd<sup>3</sup></b>	46.1 m <sup>3</sup>	<b>60.3 yd<sup>3</sup></b>	74.9 m <sup>3</sup>	<b>98.0 yd<sup>3</sup></b>
Width	5537 mm	<b>18'2"</b>	5940 mm	<b>18'10"</b>	6191 mm	<b>20'1"</b>	7416 mm	<b>24'4"</b>
Height	1930 mm	<b>6'4"</b>	2540 mm	<b>8'4"</b>	2794 mm	<b>9'2"</b>	3330 mm	<b>10'11"</b>
Weight	3200 kg	<b>7050 lb</b>	4490 kg	<b>9900 lb</b>	6670 kg	<b>14,700 lb</b>	11 340 kg	<b>25,000 lb</b>

WOODCHIP DOZERS	D6T		D7E		D7E LGP	
Capacity	15 m <sup>3</sup>	<b>20 yd<sup>3</sup></b>	23.5 m <sup>2</sup>	<b>30.8 yd<sup>2</sup></b>	23.5 m <sup>2</sup>	<b>30.8 yd<sup>2</sup></b>
Width	4267 mm	<b>14'0"</b>	4902 mm	<b>193"</b>	4902 mm	<b>193"</b>
Height	1880 mm	<b>6'2"</b>	2286 mm	<b>90"</b>	2286 mm	<b>90"</b>
Weight	1724 kg	<b>3800 lb</b>	2731 kg	<b>6020 lb</b>	2896 kg	<b>6384 lb</b>

WOODCHIP DOZERS	D8R/D8T		D9R/D9T		D10T2	
Capacity	28.3 m <sup>3</sup>	<b>37 yd<sup>3</sup></b>	45.9 m <sup>3</sup>	<b>60 yd<sup>3</sup></b>	72.6 m <sup>3</sup>	<b>95 yd<sup>3</sup></b>
Width	5486 mm	<b>18'0"</b>	5486 mm	<b>18'0"</b>	6300 mm	<b>20'8"</b>
Height	2337 mm	<b>7'8"</b>	3086 mm	<b>10'1.5"</b>	3480 mm	<b>11'5"</b>
Weight	2903 kg	<b>6400 lb</b>	5080 kg	<b>11,200 lb</b>	7575 kg	<b>16,700 lb</b>

RECLAMATION U-BLADES	D8R/D8T		D9R/D9T		D10T2	
Capacity	16.4 m <sup>3</sup>	<b>21.5 yd<sup>3</sup></b>	20.9 m <sup>3</sup>	<b>27.3 yd<sup>3</sup></b>	30.6 m <sup>3</sup>	<b>40 yd<sup>3</sup></b>
Width	4877 mm	<b>16'0"</b>	5182 mm	<b>17'0"</b>	5664 mm	<b>18'7"</b>
Height	1880 mm	<b>6'2"</b>	2032 mm	<b>6'8"</b>	2388 mm	<b>7'10"</b>
Weight	3810 kg	<b>8400 lb</b>	5220 kg	<b>11,500 lb</b>	6440 kg	<b>14,200 lb</b>

CUSHION DOZERS	D8R/D8T		D9R/D9T		D10T2		D11T	
Width	2889 mm	<b>9'5.75"</b>	3048 mm	<b>10'0"</b>	3505 mm	<b>11'6"</b>		
Height	1499 mm	<b>4'11"</b>	1575 mm	<b>5'2"</b>	1676 mm	<b>5'6"</b>		*
Weight	3185 kg	<b>7020 lb</b>	4310 kg	<b>9500 lb</b>	6440 kg	<b>14,200 lb</b>		
Rear Cushion								
Push Block		*	2175 kg	<b>4800 lb</b>	3105 kg	<b>6850 lb</b>		*

\*Available upon request.  
This list is not all inclusive.





# RIPPERS

## CONTENTS

Features .....	19-59
Ripper Specification Diagrams	
Adjustable Parallelogram Ripper .....	19-60
Radial Ripper .....	19-62
Fixed Parallelogram Ripper .....	19-62
Specifications	
Track-Type Tractors .....	19-63
Tip Selection .....	19-73
Estimating Ripping Production .....	19-73
Seismic Wave Velocity Charts .....	19-76
Estimated Ripper Production Graphs .....	19-81

## Features:

- **Parallelogram linkage with hydraulically variable pitch** on D7E, D7R, D8R/D8T, D9R/D9T, D10T2 and D11T. Operator can adjust angle of ripper tip to the material for penetration at all ripping depths to increase production.
- **Fixed Parallelogram linkage design** used on D3K2, D4K2, D5K2, D6K2, D6N, D6R, D6R XL, D6T and D6T XL. This design holds tooth angle constant at all ripping depths.
- **Adjustable Single shank** arrangements available for D8R/D8T, D9R/D9T, D10T2 and D11T for tough ripping applications and deep ripping requirements.
- **Hydraulically Variable Pitch Multi-shank** arrangements available on D7E, D7R, D8R/D8T, D9R/D9T, D10T2 and D11T allow wide-beam coverage in easier-to-rip materials.
- **Counterweighted CarryDozer Ripper single shank** available for D11T and D11T CD, multi-shank available for D11T CD.

**DEFINITION OF FORCES SHOWN IN TABLES THAT FOLLOW**

“Pryout,” (Breakout) kilonewtons (and pounds) — the maximum sustained upward force, generated by the lift cylinders measured at the ripper tip. Breakout force is measured with the shank in the top hole, shank vertical and ripper full down. Breakout force may be hydraulically or balance limited.

“Penetration force,” kilonewtons (and pounds) — the maximum sustained downward force, generated by the ripper lift cylinders measured at the ripper tip, which is required to raise the back end of the vehicle with the tip on ground and the shank (pinned in the top hole) vertical.

**Adjustable Parallelogram Ripper**

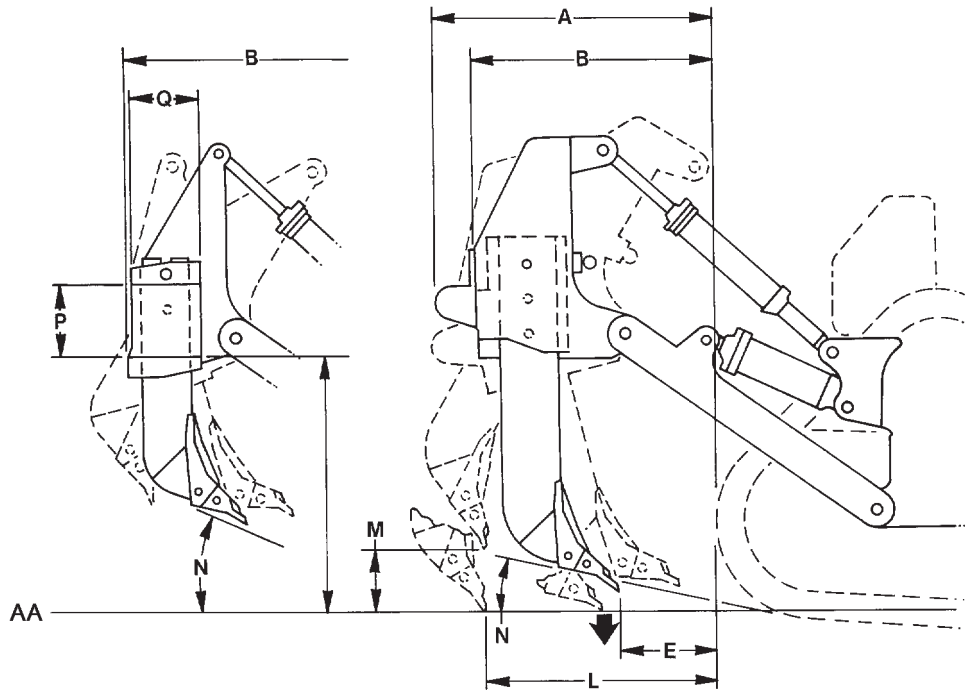

**NOTE:** Letters correspond to ripper specifications on pages that follow.

**KEY**

AA — Ground Line

Adjustable Parallelogram Ripper

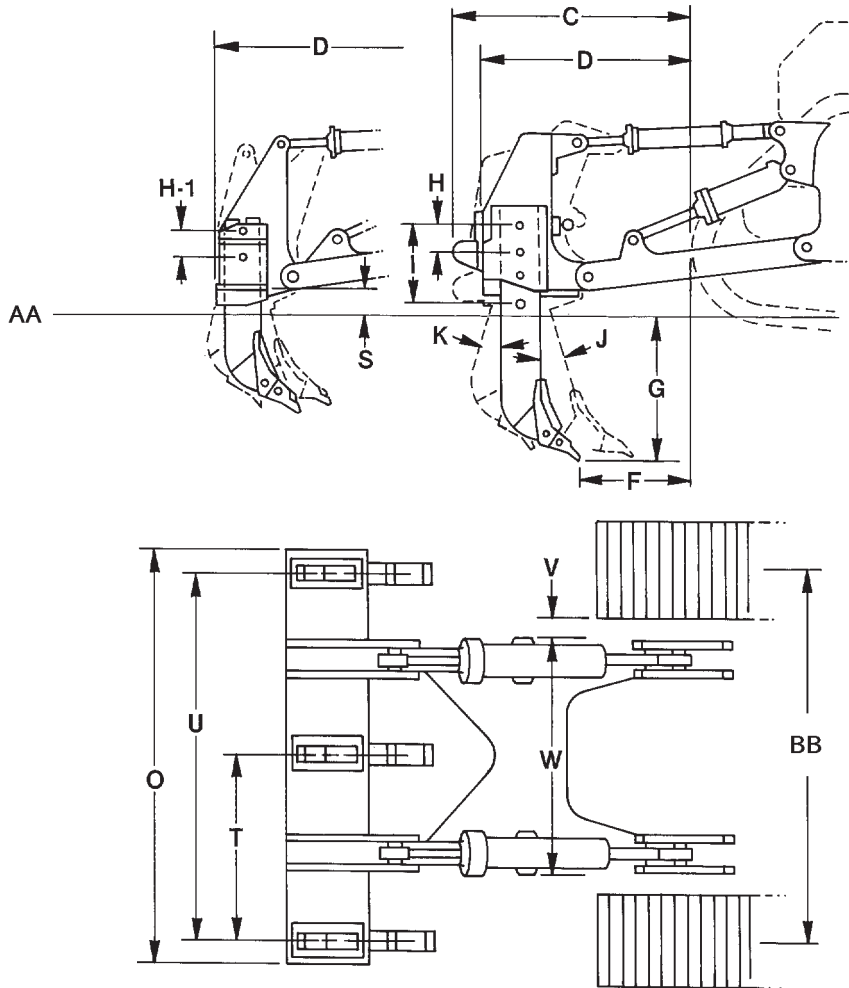

NOTE: Letters correspond to ripper specifications on pages that follow.

KEY

- AA — Ground Line
- BB — Track Gauge

# Rippers

## Specification Diagrams

- Radial Ripper
- Fixed Parallelogram Ripper

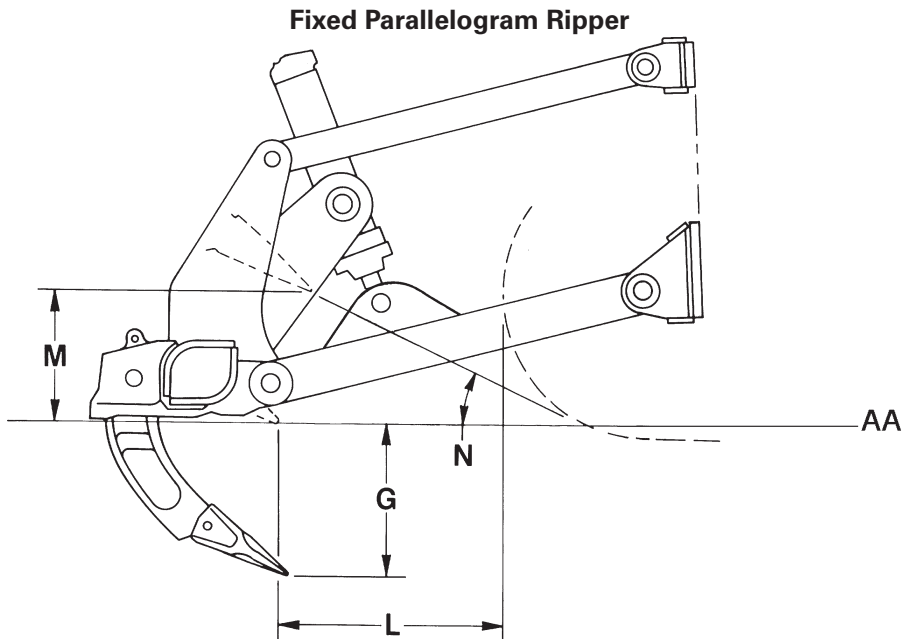
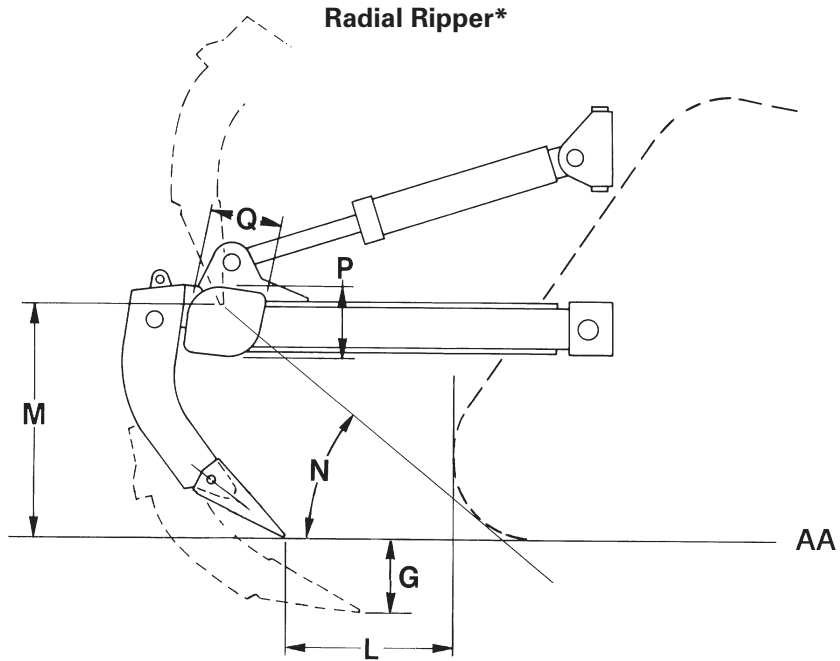

NOTE: Letters correspond to ripper specifications on pages that follow.

#### KEY

- AA — Ground Line
- \* — Tip Standard

TRACTOR/RIPPER	D3K2**		D3K2		D4K2**	
Ripper Type	Fixed Parallelogram		Fixed Parallelogram		Fixed Parallelogram	
Dimensions:						
<b>Ripper Shank</b>						
<b>G</b> Maximum digging depth	338 mm	13.3"	338 mm	13.3"	338 mm	13.3"
<b>L</b> Maximum reach at ground line	766 mm	30.2"	766 mm	30.2"	596 mm	23.5"
<b>M</b> Maximum ground clearance under tip (shank pinned in bottom hole)	448 mm	17.6"	448 mm	17.6"	448 mm	17.6"
<b>N</b> Maximum ramp angle, ripper up (shank pinned in bottom hole)	27°		27°		32°	
Shank section	36 × 76 mm	1.4" × 3"	36 × 76 mm	1.4" × 3"	36 × 76 mm	1.4" × 3"
<b>Ripper Beam</b>						
<b>O</b> Overall width	1710 mm	67.3"	1710 mm	67.3"	1710 mm	67.3"
<b>P</b> Height	165 mm	6.5"	165 mm	6.5"	165 mm	6.5"
<b>Q</b> Length	190 mm	7.5"	190 mm	7.5"	190 mm	7.5"
Number of Pockets	3		3		3	
<b>T</b> Pocket Spacing	775 mm	30.5"	775 mm	30.5"	775 mm	30.5"
<b>U</b> Shank Gauge	1550 mm	61.0"	1.55 m	61.0"	1550 mm	61.0"
<b>V</b> Track clearance with standard shoe	80 mm	3.2"	80 mm	3.2"	80 mm	3.2"
Installed weights:						
Ripper with standard shank	554 kg	1222 lb	554 kg	1222 lb	554 kg	1222 lb
<b>Ripper Forces:*</b>						
Penetration Force	22.1 kN	4970 lb	22.1 kN	4970 lb	24.7 kN	5560 lb
Pryout Force	44.0 kN	9900 lb	44.0 kN	9900 lb	44.0 kN	9900 lb

TRACTOR/RIPPER	D4K2		D5K2**		D5K2	
Ripper Type	Fixed Parallelogram		Fixed Parallelogram		Fixed Parallelogram	
Dimensions:						
<b>Ripper Shank</b>						
<b>G</b> Maximum digging depth	338 mm	13.3"	338 mm	13.3"	338 mm	13.3"
<b>L</b> Maximum reach at ground line	766 mm	30.2"	555 mm	21.9"	766 mm	30.2"
<b>M</b> Maximum ground clearance under tip (shank pinned in bottom hole)	448 mm	17.6"	448 mm	17.6"	448 mm	17.6"
<b>N</b> Maximum ramp angle, ripper up (shank pinned in bottom hole)	27°		33°		27°	
Shank section	36 × 76 mm	1.4" × 3"	36 × 76 mm	1.4" × 3"	36 × 76 mm	1.4" × 3"
<b>Ripper Beam</b>						
<b>O</b> Overall width	1710 mm	67.3"	1710 mm	67.3"	1710 mm	67.3"
<b>P</b> Height	165 mm	6.5"	165 mm	6.5"	165 mm	6.5"
<b>Q</b> Length	190 mm	7.5"	190 mm	7.5"	190 mm	7.5"
Number of Pockets	3		3		3	
<b>T</b> Pocket Spacing	775 mm	30.5"	775 mm	30.5"	775 mm	30.5"
<b>U</b> Shank Gauge	1.55 m	61.0"	1550 mm	61.0"	1.55 m	61.0"
<b>V</b> Track clearance with standard shoe	80 mm	3.2"	80 mm	3.2"	80 mm	3.2"
Installed weights:						
Ripper with standard shank	554 kg	1222 lb	554 kg	1222 lb	554 kg	1222 lb
<b>Ripper Forces:*</b>						
Penetration Force	22.1 kN	4970 lb	27.3 kN	6130 lb	22.1 kN	4970 lb
Pryout Force	44.0 kN	9900 lb	44.0 kN	9900 lb	44.0 kN	9900 lb

\*This value may vary slightly with various vehicle configurations.  
 \*\*Meets Tier 3/Stage IIIA/Japan 2006 (Tier 3) equivalent emission standards.  
 NOTE: Letters correspond to ripper dimension drawings.

TRACTOR/RIPPER	D5R2 XL/D5R2 LGP		D6K2 XL	
Ripper Type	Parallelogram		Fixed Parallelogram	
Dimensions:				
<b>Ripper Shank</b>				
<b>G</b> Maximum digging depth	355 mm	<b>14.0"</b>	355 mm	<b>14.0"</b>
<b>L</b> Maximum reach at ground line	516 mm	<b>1'8.3"</b>	725 mm	<b>28.5"</b>
<b>M</b> Maximum ground clearance under tip (shank pinned in bottom hole)	422 mm	<b>16.6"</b>	471 mm	<b>18.5"</b>
<b>N</b> Maximum ramp angle, ripper up (shank pinned in bottom hole)	<b>21.4°</b>		<b>24.8°</b>	
<b>Ripper Beam</b>				
<b>O</b> Overall width	2200 mm	<b>7'3"</b>	1951 mm	<b>6'4.8"</b>
<b>P</b> Height	216 mm	<b>8.5"</b>	165 mm	<b>6.5"</b>
<b>Q</b> Length	254 mm	<b>10"</b>	211 mm	<b>8.3"</b>
Number of Pockets	<b>3</b>		<b>3</b>	
<b>T</b> Pocket Spacing	1000 mm	<b>3'3.4"</b>	896 mm	<b>2'11.3"</b>
<b>U</b> Shank Gauge	2000 mm	<b>6'7"</b>	1792 mm	<b>5'10.6"</b>
<b>V</b> Track clearance with standard shoe	99 mm	<b>3.9"</b>	81 mm	<b>3.2"</b>
Installed weights:				
Ripper with standard shank	1406 kg	<b>3100 lb</b>	908 kg	<b>2002 lb</b>
Each additional shank	78 kg	<b>172 lb</b>	34 kg	<b>75 lb</b>
<b>Ripper Forces:</b>				
Penetration Force	51.6 kN	<b>11,600 lb</b>	43 kN	<b>9666.8 lb</b>
Pryout Force	211.2 kN	<b>47,480 lb</b>	170 kN	<b>38,218 lb</b>

NOTE: Letters correspond to ripper dimension drawings.

TRACTOR/RIPPER	D6K2 LGP		D6R2	
Ripper Type	Fixed Parallelogram		Parallelogram	
Dimensions:				
<b>Ripper Shank</b>				
<b>G</b> Maximum digging depth	355 mm	14.0"	495 mm	1'8"
<b>L</b> Maximum reach at ground line	725 mm	28.5"	733 mm	2'5"
<b>M</b> Maximum ground clearance under tip (shank pinned in bottom hole)	471 mm	18.5"	518 mm	1'8"
<b>N</b> Maximum ramp angle, ripper up (shank pinned in bottom hole)		24.8°		26°
Shank section		—	74 × 175 mm	2.9" × 6.9"
<b>Ripper Beam</b>				
<b>O</b> Overall width	1951 mm	6'4.8"	2.20 m	7'3"
<b>P</b> Height	165 mm	6.5"	216 mm	8.5"
<b>Q</b> Length	211 mm	8.3"	254 mm	10"
Number of Pockets		3		3
<b>T</b> Pocket Spacing	896 mm	2'11.3"	1000 mm	3'3"
<b>U</b> Shank Gauge	1792 mm	5'10.6"	2 m	6'7"
<b>V</b> Track clearance with standard shoe	89 mm	3.5"	120 mm	4.7"
Installed weights:				
Ripper with standard shank	845 kg	1863 lb	1508 kg	3324 lb
Each additional shank	34 kg	75 lb	73 kg	160 lb
<b>Ripper Forces:*</b>				
Penetration Force	46 kN	10,641 lb	65.6 kN	14,747 lb
Pryout Force	170 kN	38,218 lb	89.6 kN	20,140 lb

\*D6R2 tractor equipped with ripper, OROPS, SU dozer and heavy duty track. Values may vary slightly with various configurations.

NOTE: Letters correspond to ripper dimension drawings.



TRACTOR/RIPPER	D6R2 XL		D6R2 LGP	
Ripper Type	Parallelogram		Parallelogram	
Dimensions:				
<b>Ripper Shank</b>				
<b>G</b> Maximum digging depth	495 mm	1'8"	445 mm	1'6"
<b>L</b> Maximum reach at ground line	733 mm	2'5"	586 mm	1'11"
<b>M</b> Maximum ground clearance under tip (shank pinned in bottom hole)	518 mm	1'8"	568 mm	1'10"
<b>N</b> Maximum ramp angle, ripper up (shank pinned in bottom hole)		26°		28.5°
Shank section	74 × 175 mm	2.9" × 6.9"	74 × 175 mm	2.9" × 6.9"
<b>Ripper Beam</b>				
<b>O</b> Overall width	2.20 m	7'3"	2.20 m	7'3"
<b>P</b> Height	216 mm	8.5"	216 mm	8.5"
<b>Q</b> Length	254 mm	10"	254 mm	10"
Number of Pockets		3		3
<b>T</b> Pocket Spacing	1000 mm	3'3"	1000 mm	3'3"
<b>U</b> Shank Gauge	2 m	6'7"	2 m	6'7"
<b>V</b> Track clearance with standard shoe	69 mm	2.7"	171 mm	6.7"
Installed weights:				
Ripper with standard shank	1508 kg	3324 lb	1508 kg	3324 lb
Each additional shank	73 kg	160 lb	73 kg	160 lb
<b>Ripper Forces:*</b>				
Penetration Force	65.6 kN	14,747 lb	65.6 kN	14,747 lb
Pryout Force	116.5 kN	20,140 lb	116.5 kN	20,140 lb

\*Tractor equipped with ripper, OROPS, SU dozer and heavy duty track. Values may vary slightly with various configurations.

NOTE: Letters correspond to ripper dimension drawings.

TRACTOR/RIPPER	D6T XL**		D6T XW**		D6T LGP**	
Ripper Type	Parallelogram		Parallelogram		Parallelogram	
Dimensions:						
<b>Ripper Shank</b>						
<b>G</b> Maximum digging depth	495 mm	1'8"	495 mm	1'8"	445 mm	1'6"
VPAT	495 mm	1'8"	445 mm	1'6"	445 mm	1'6"
<b>L</b> Maximum reach at ground line	733 mm	2'5"	733 mm	2'5"	586 mm	1'11"
VPAT	733 mm	2'5"	586 mm	1'11"	586 mm	1'11"
<b>M</b> Maximum ground clearance under tip (shank pinned in bottom hole)	518 mm	1'8"	518 mm	1'8"	568 mm	1'10"
VPAT	518 mm	1'8"	568 mm	1'10"	568 mm	1'10"
<b>N</b> Maximum ramp angle, ripper up (shank pinned in bottom hole)		26°		26°		28.5°
VPAT		26°		28.5°		28.5°
Shank section	74 × 175 mm 2.9" × 6.9"		74 × 175 mm 2.9" × 6.9"		74 × 175 mm 2.9" × 6.9"	
<b>Ripper Beam</b>						
<b>O</b> Overall width	2.20 m	7'3"	2.20 m	7'3"	2.20 m	7'3"
<b>P</b> Height	216 mm	8.5"	216 mm	8.5"	216 mm	8.5"
<b>Q</b> Length	254 mm	10"	254 mm	10"	254 mm	10"
Number of Pockets		3		3		3
<b>T</b> Pocket Spacing	1000 mm	3'3"	1000 mm	3'3"	1000 mm	3'3"
<b>U</b> Shank Gauge	2 m	6'7"	2 m	6'7"	2 m	6'7"
<b>V</b> Track clearance with standard shoe	120 mm	4.7"	69 mm	2.7"	171 mm	6.7"
VPAT	374 mm	1'3"	374 mm	1'3"	374 mm	1'3"
Installed weights:						
Ripper with standard shank	1508 kg	3324 lb	1508 kg	3324 lb	1508 kg	3324 lb
Each additional shank	73 kg	160 lb	73 kg	160 lb	73 kg	160 lb
<b>Ripper Forces:*</b>						
Penetration Force	15.6 kN	3,507 lb	67.7 kN	15,220 lb	72.4 kN	16,276 lb
Pryout Force	116.5 kN	26,190 lb	116.5 kN	26,190 lb	116.5 kN	26,190 lb

\*Tractor equipped with ripper, cab, SU dozer, and standard track.

\*\*Meets Tier 4 Final/Stage IV/Japan 2014 (Tier 4 Final) emission standards.

NOTE: Letters correspond to ripper dimension drawings.

TRACTOR/RIPPER	D7R	
<b>Ripper Type</b>	<b>Adjustable Parallelogram</b>	
Dimensions:		
<b>Ripper Shank</b>		
<b>G</b> Maximum digging depth	748 mm	2'5.4"
<b>L</b> Maximum reach at ground line	1.07 m	3'6.1"
<b>M</b> Maximum ground clearance under tip (shank pinned in bottom hole)	638 mm	2'1.1"
<b>N</b> Maximum ramp angle, ripper up (shank pinned in bottom hole)	<b>26.6°</b>	
Shank section	72 × 228 mm	<b>2.8" × 6.9"</b>
<b>Ripper Beam</b>		
<b>O</b> Overall width	2.21 m	<b>7'3"</b>
<b>P</b> Height	279 mm	<b>11"</b>
<b>Q</b> Length	343 mm	<b>13.5"</b>
Number of Pockets	<b>3</b>	
<b>T</b> Pocket Spacing	991 mm	<b>3'3"</b>
<b>U</b> Shank Gauge	1.98 m	<b>6'6"</b>
<b>V</b> Track clearance with standard shoe	95 mm	<b>3.7"</b>
Installed weights:		
Ripper with standard shank	3277 kg	<b>7225 lb</b>
Each additional shank	138 kg	<b>305 lb</b>
<b>Ripper Forces:*</b>		
Penetration Force	85.0 kN	<b>19,104 lb</b>
Pryout Force	176.6 kN	<b>39,705 lb</b>

\*Tractor equipped with ripper, OROPS, SU dozer and heavy duty track. Values may vary slightly with various configurations.

**NOTE:** Letters correspond to ripper dimension drawings.

TRACTOR/RIPPER	D7E		D8R/D8T			
	Adjustable Parallelogram		Adjustable Parallelogram			
Ripper Type	Multi-shank		Single Shank		Multi-shank	
Dimensions:						
<b>Ripper to Track</b>						
Ripper length behind track, shank vertical, ripper up						
<b>A</b> With Pushblock	N/A		N/A		N/A	
<b>B</b> Without Pushblock	1222 mm	4'0"	1.69 m	5'7"	1.6 m	5'2"
Ripper length behind track, shank vertical, ripper down						
<b>C</b> With Pushblock	N/A		N/A		N/A	
<b>D</b> Without Pushblock	1660 mm	5'5"	1.84 m	6'0"	1.71 m	5'7"
Tip to track distance, shank vertical						
<b>E</b> Ripper Up	614 mm	2'0"	694 mm	2'3.3"	640 mm	2'1.2"
<b>F</b> Ripper Down	970 mm	3'2"	950 mm	3'1.4"	899 mm	2'11.4"
<b>Ripper Shank*</b>						
<b>G</b> Maximum digging depth	650 mm	2'2"	1130 mm	3'8.5"	780 mm	2'6.7"
<b>H</b> Dig adjustment per hole	230 mm	9"	305 mm	12"	250 mm	10"
<b>I</b> Total dig adjustment	230 mm	9"	610 mm	2'0"	250 mm	10"
Pitch Adjustment, ripper down:						
<b>J</b> Forward	16°		15°		14.9°	
<b>K</b> Backward	12°		9.9°		10°	
<b>L</b> Maximum reach at ground line	1156 mm	3'10"	1.32 m	4'3"	1.17 m	3'10"
<b>M</b> Maximum ground clearance under tooth (shank pinned in bottom hole)	588 mm	1'11"	636 mm	2'1"	593 mm	1'11.3"
<b>N</b> Maximum ramp angle, ripper up (shank pinned in bottom hole)	26°		28.2°		28.4°	
Shank Section	72 × 228 mm	2.8" × 9.0"	75 × 333 mm	2.9" × 13.1"	75 × 333 mm	2.9" × 13.1"
<b>Ripper Beam</b>						
<b>O</b> Overall width	2088 mm	6'10"	N/A		2.46 m	8'1"
<b>P</b> Height** (dia)	355.6 mm	14" (dia)	N/A		334 mm	13.1"
<b>Q</b> Length**	—		N/A		457 mm	18"
Clearance under beam, shank vertical						
<b>R</b> Ripper Up	1080 mm	3'7"	N/A		1.55 m	5'1"
<b>S</b> Ripper Down	145 mm	5.7"	N/A		449 mm	17.7"
Number of Pockets						
<b>T</b> Pocket Spacing	900 mm	2'11"	N/A		1092 mm	3'7"
<b>U</b> Shank Gauge	1800 mm	5'11"	N/A		2.17 m	7'1"
<b>V</b> Track Clearance with standard shoe	47 mm	1.9"	76 mm	3"	76 mm	3"
<b>W</b> Width across widest part of lift cylinders	1275 mm	4'2"	1.37 m	4'5"	1.37 m	4'5"
Installed Weights:						
Ripper with standard shank						
	1650 kg	3572 lb	4085 kg	9005 lb	4213 kg	9287 lb
Each additional tooth group						
	150 kg	330 lb	N/A		332 kg	730 lb
<b>Ripper Forces:***</b>						
Penetration Force, shank vertical						
	87.4 kN	19,639 lb	127.4 kN	28,620 lb	124.2 kN	27,920 lb
Pryout Force, shank vertical						
	234.4 kN	52,695 lb	222.8 kN	50,070 lb	227.9 kN	51,230 lb

\*Deep Ripping Shank is available for D8R/D8T single shank rippers. Hydraulic pin puller is standard with deep ripping shank. Deep Ripping Arrangement maximum digging depth is 1.57 m (5'2") for D8R/D8T.

\*\*D7E ripper beam circular cross section.

\*\*\*Forces for D7E are for machine equipped with SU-blade and standard track. Forces for D8R/D8T are for a ripper on a tractor equipped with EROPS, U-Dozer and performance track. Forces will vary slightly with other vehicle configurations.

NOTE: Letters correspond to ripper dimension drawings.

## TRACTOR/RIPPER

## D9R/D9T

Ripper Type	Adjustable Parallelogram			
	Single Shank		Multi-shank	
Dimensions:				
<b>Ripper to Track</b>				
Ripper length behind track, shank vertical, ripper up				
<b>A</b> With Pushblock		N/A		N/A
<b>B</b> Without Pushblock	1.57 m	5'2"	1.33 m	4'4"
Ripper length behind track, shank vertical, ripper down				
<b>C</b> With Pushblock		N/A		N/A
<b>D</b> Without Pushblock	1.88 m	6'2"	1.71 m	5'7"
Tip to track distance, shank vertical				
<b>E</b> Ripper Up	689 mm	2'3.2"	510 mm	1'8.1"
<b>F</b> Ripper Down	944 mm	3'1.2"	890 mm	2'11"
<b>Ripper Shank*</b>				
<b>G</b> Maximum digging depth	1231 mm	4'0.6"	798 mm	2'7.6"
<b>H</b> Dig adjustment per hole	295 mm	12"	250 mm	10"
<b>I</b> Total dig adjustment	590 mm	1'11.2"	250 mm	10"
Pitch Adjustment, ripper down:				
<b>J</b> Forward		10.6°		10°
<b>K</b> Backward		15.2°		15.1°
<b>L</b> Maximum reach at ground line	1.25 m	4'1"	1.16 m	3'10"
<b>M</b> Maximum ground clearance under tooth (shank pinned in bottom hole)	882 mm	2'10.9"	879 mm	2'10.6"
<b>N</b> Maximum ramp angle, ripper up (shank pinned in bottom hole)		36.9°		37.5°
Shank Section	90 × 355 mm	3.5" × 14"	75 × 332 mm	2.9" × 13.1"
<b>Ripper Beam</b>				
<b>O</b> Overall width		N/A	2.64 m	8'8"
<b>P</b> Height		N/A	380 mm	15"
<b>Q</b> Length		N/A	457 mm	18"
Clearance under beam, shank vertical				
<b>R</b> Ripper Up		N/A	1.77 m	5'10"
<b>S</b> Ripper Down		N/A	393 mm	15.5"
Number of Pockets		1		3
<b>T</b> Pocket Spacing		N/A	1176 mm	3'10.3"
<b>U</b> Shank Gauge		N/A	2.35 m	7'8"
<b>V</b> Track Clearance with standard shoe	71 mm	2.8"	71 mm	2.8"
<b>W</b> Width across widest part of lift cylinders	1.50 m	4'11"	1.50 m	4'11"
Installed Weights:				
Ripper with standard shank	4293 kg	9464 lb	4153 kg	9156 lb
Each additional tooth group		N/A	347 kg	765 lb
<b>Ripper Forces:**</b>				
Penetration Force, shank vertical	158 kN	35,520 lb	154 kN	34,621 lb
Pryout Force, shank vertical	332 kN	74,637 lb	361 kN	81,156 lb

\*Deep Ripping Shank is available for D9R/D9T single shank rippers. Hydraulic pin puller is standard with deep ripping shank. Deep Ripping Arrangement maximum digging depth is 1.66 m (5'5") for D9R/D9T.

\*\*Forces are for a ripper on a tractor equipped with EROPS, U-Dozer and performance track. Forces will vary slightly with other vehicle configurations.

NOTE: Letters correspond to ripper dimension drawings.

TRACTOR/RIPPER	D10T2		D11T		D11T	
	Adjustable Parallelogram		Adjustable Parallelogram		Adjustable Parallelogram	
Ripper Type	Single Shank	Multi-shank	Single Shank	CD Single Shank	Single Shank	CD Single Shank
Dimensions:						
<b>Ripper to Track</b>						
Ripper length behind track, shank vertical, ripper up (A)						
<b>A</b> With Pushblock	2.08 m <b>6'10"</b>	N/A	2.29 m <b>7'6"</b>	N/A		
<b>B</b> Without Pushblock	1.76 m <b>5'9"</b>	1.56 m <b>5'1"</b>	1.97 m <b>6'6"</b>	2.26 m <b>7'5"</b>		
Ripper length behind track, shank vertical, ripper down (A)						
<b>C</b> With Pushblock	2.48 m <b>8'2"</b>	N/A	2.71 m <b>8'11"</b>	N/A		
<b>D</b> Without Pushblock	2.16 m <b>7'1"</b>	1.96 m <b>6'5"</b>	2.39 m <b>7'10"</b>	2.52 m <b>8'3"</b>		
Tip to track distance, shank vertical (A)						
<b>E</b> Ripper Up*	730 mm <b>2'4.7"</b>	651 mm <b>2'1.6"</b>	751 mm <b>2'6"</b>	751 mm <b>2'6"</b>		
<b>F</b> Ripper Down**	1130 mm <b>3'8.5"</b>	1050 mm <b>3'5.3"</b>	1174 mm <b>3'10"</b>	1174 mm <b>3'10"</b>		
<b>Ripper Shank***</b>						
<b>G</b> Maximum digging depth**	1504 mm <b>4'11"</b>	950 mm <b>3'1.4"</b>	1612 mm <b>5'3"</b>	1612 mm <b>5'3"</b>		
<b>H</b> Dig adjustment per hole	355 mm <b>14"</b>	250 mm <b>10"</b>	280 mm <b>11"</b>	280 mm <b>11"</b>		
<b>I</b> Total dig adjustment	710 mm <b>2'4"</b>	250 mm <b>10"</b>	840 mm <b>2'9.1"</b>	840 mm <b>2'9.1"</b>		
Pitch Adjustment, ripper down:						
<b>J</b> Forward	<b>15.4°</b>	<b>18.1°</b>	<b>15°</b>	<b>13°</b>		
<b>K</b> Backward	<b>29.7°</b>	<b>23.2°</b>	<b>31.9°</b>	<b>31.9°</b>		
<b>L</b> Maximum reach at ground line**	1.60 m <b>5'3"</b>	1.39 m <b>4'7"</b>	1.87 m <b>6'2"</b>	1.87 m <b>6'2"</b>		
<b>M</b> Maximum ground clearance under tooth (shank pinned in bottom hole)	912 mm <b>3'0"</b>	1055 mm <b>3'5.5"</b>	1111 mm <b>3'9.7"</b>	1115 mm <b>3'8"</b>		
<b>N</b> Maximum ramp angle, ripper up (shank pinned in bottom hole)	<b>35.7°</b>	<b>50.9°</b>	<b>34.1°</b>	<b>34.1°</b>		
Shank Section						
	100 × 400 mm <b>(4" × 15.75")</b>	90 × 355 mm <b>(3.5" × 14")</b>	110 × 450 mm <b>(4.3" × 17.7")</b>	110 × 450 mm <b>(4.3" × 17.7")</b>		
<b>Ripper Beam</b>						
<b>O</b> Overall width	N/A	2.92 m <b>9'7"</b>	N/A	N/A		
<b>P</b> Height	N/A	468 mm <b>18.4"</b>	N/A	N/A		
<b>Q</b> Length	N/A	485 mm <b>19.1"</b>	N/A	N/A		
Clearance under beam, shank vertical						
<b>R</b> Ripper Up	N/A	2.03 m <b>6'8"</b>	N/A	N/A		
<b>S</b> Ripper Down	N/A	380 mm <b>15"</b>	N/A	N/A		
Number of Pockets						
	<b>1</b>	<b>3</b>	<b>1</b>	<b>1</b>		
<b>T</b> Pocket Spacing	N/A	1320 mm <b>4'4"</b>	N/A	N/A		
<b>U</b> Shank Gauge	N/A	2.63 m <b>8'8"</b>	N/A	N/A		
<b>V</b> Track Clearance with standard shoe	97 mm <b>4"</b>	97 mm <b>4"</b>	141 mm <b>5.6"</b>	141 mm <b>5.6"</b>		
<b>W</b> Width across widest part of lift cylinders	1.75 m <b>5'9"</b>	1.75 m <b>5'9"</b>	1.90 m <b>6'3"</b>	1.90 m <b>6'3"</b>		
Installed Weights:						
Ripper with standard shank						
	6445 kg <b>14,209 lb</b>	6132 kg <b>13,519 lb</b>	8817 kg <b>19,438 lb</b>	12 461 kg <b>27,472 lb</b>		
Each additional tooth group						
	N/A	544 kg <b>1200 lb</b>	N/A	N/A		
<b>Ripper Forces:****</b>						
Penetration Force, shank vertical						
	219 kN <b>49,233 lb</b>	208 kN <b>46,760 lb</b>	350 kN <b>78,683 lb</b>	381 kN <b>85,652 lb</b>		
Pryout Force, shank vertical						
	512 kN <b>115,102 lb</b>	515 kN <b>115,777 lb</b>	638 kN <b>143,428 lb</b>	629 kN <b>141,405 lb</b>		

\*With Standard Shank pinned in the bottom hole.

\*\*With Standard Shank pinned in the top hole.

\*\*\*Deep Ripping Shank is available for the D10T2 and D11T single shank rippers. Deep Ripping Arrangement maximum digging depth is 1.80 m (5'11") for the D10T2 and 2.17 m (7'1") for the D11T.

\*\*\*\*Forces are for a ripper on a tractor equipped with an EROPS, U-Dozer and performance track. Forces will vary slightly with other machine configurations. All dimensions are approximate.

TRACTOR/RIPPER	D11T		D11T	
	Adjustable Parallelogram			
Ripper Type	Multi-shank		CD Multi-shank	
Dimensions:				
<b>Ripper to Track</b>				
Ripper length behind track, shank vertical, ripper up (A)				
<b>A</b> With Pushblock		N/A		N/A
<b>B</b> Without Pushblock	1.69 m	5'6"	1.71 m	5'8"
Ripper length behind track, shank vertical, ripper down (A)				
<b>C</b> With Pushblock		N/A		N/A
<b>D</b> Without Pushblock	2.16 m	7'1"	2.16 m	7'1"
Tip to track distance, shank vertical (A)				
<b>E</b> Ripper Up	0.78 m	2'7"	0.78 m	2'7"
<b>F</b> Ripper Down	1.95 m	6'5"	1.96 m	6'5"
<b>Shank*</b>				
<b>G</b> Maximum digging depth	1100 mm	3'7.3"	1100 mm	3'7.3"
<b>H</b> Dig adjustment per hole	280 mm	11"	280 mm	11"
<b>I</b> Total dig adjustment	280 mm	11"	280 mm	11"
Pitch Adjustment, ripper down:				
<b>J</b> Forward		12.2°		12.2°
<b>K</b> Backward		31.8°		31.8°
<b>L</b> Maximum reach at ground line	1.71 m	5'7"	1.71 m	5'7"
<b>M</b> Maximum ground clearance under tooth (shank pinned in bottom hole)				
	1090 mm	3'6.9"	1090 mm	3'6.9"
<b>N</b> Maximum ramp angle, ripper up (shank pinned in bottom hole)				
		36.4°		36.4°
Shank Section				
	100 × 400 mm	3.9" × 15.7"	100 × 400 mm	3.9" × 15.7"
<b>Ripper Beam</b>				
<b>O</b> Overall width	3.33 m	10'11"	3.34 m	10'11.5"
<b>P</b> Height	560 mm	22"	595 mm	23.4"
<b>Q</b> Length	560 mm	22"	595 mm	23.4"
Clearance under beam, shank vertical				
<b>R</b> Ripper Up	2.06 m	6'9"	2.03 m	6'8"
<b>S</b> Ripper Down	282 mm	11.1"	247 mm	9.7"
Number of Pockets				
		3		3
<b>T</b> Pocket Spacing	1.5 m	4'11"	1.5 m	4'11"
<b>U</b> Shank Gauge	3.0 m	9'10"	3.0 m	9'10"
<b>V</b> Track Clearance with standard shoe	166 mm	5.6"	166 mm	5.6"
<b>W</b> Width across widest part of lift cylinders	1.9 m	6'3"	1.9 m	6'3"
Installed Weights:				
Ripper with standard shank				
	8674 kg	19,123 lb	11 790 kg	25,993 lb
Each additional tooth group				
	689 kg	1519 lb	689 kg	1519 lb
<b>Ripper Forces:**</b>				
Penetration Force, shank vertical				
	335 kN	75,311 lb	365 kN	82,055 lb
Pryout Force, shank vertical				
	632 kN	142,079 lb	636 kN	142,978 lb

\*Hydraulic pin puller is standard with deep ripping shank. Deep Ripping Arrangement maximum digging depth is 2.18 m (7'2").

\*\*Forces are for a ripper on a tractor equipped with an EROPS, U-Dozer and performance track. Forces will vary slightly with other vehicle configurations.

**TIP SELECTION FOR THE D8R/D8T, D9R/D9T, D10T2 AND D11T RIPPERS**

Three tip configurations (short, intermediate and long) in two styles (centerline and penetration) are available for economical operation in a variety of conditions.

**RECOMMENDED TIP USAGE**

*Short* — Use in high impact conditions where breakage problems occur. The shorter the tip, the more it resists breakage.

*Intermediate* — Most effective in moderate impact conditions where abrasion is not excessive.

*Long* — Use in loose, abrasive materials where breakage is not a problem. Generally offers the most wear material.

**Centerline vs Penetration**

The materials being ripped and the tractor doing the ripping will both have an effect on which tip will do the best job. High density material requires a “penetration” tip. High impact material requires a “centerline” tip. The following is a general guide to tip application.

Ripping Condition	Tips to use		
	D8R/D8T D9R/D9T	D10T2	D11T
Tandem Tractors . . . . .	Short	Short	Short
Single Shank and Multi-shank			
Extreme Duty . . . . .	Int.	Short	Short
Medium Duty . . . . .	Long	Int.	Int.
Abrasive Duty . . . . .	Long	Long	Long

Always use the longest tip that will wear without excessive breakage. Different tips should be tried to determine the most economical.

**ESTIMATING RIPPING PRODUCTION**

Ripping costs must be compared to other methods of loosening the material — usually drilling and blasting — on a cost per ton or bank cubic yard basis. Thus, an accurate estimation of ripper production is needed to determine unit ripping costs.

There are three general methods of estimating ripping production:

1. The best method is to record the time spent ripping, then remove (using scrapers or loaders and trucks) and weigh the ripped material. The total weight divided by the time spent will give hourly production. If the contractor is paid by volume, then a density must be used and the accuracy is only as good as the density used. For payment by volume removed, method 2 may be desirable. Some care will be needed to assure that only ripped material is removed.
2. Another method is to cross-section the area and then record the time spent ripping. After the material has been removed, cross-section the area again to determine the volume of rock removed. The volume divided by the time spent ripping gives the ripping rate per minute or hour.
3. Timing the ripper over a measured distance is the least accurate method, but valuable for quick estimating on the job. An average cycle time should be determined from a number of timed cycles. Turn-around or back-up time must be included. Measure the average rip distance, rip spacing and depth of penetration. This data will give the volume per cycle from which the production in bank cubic yards can be calculated. Experience has shown results obtained from this method are about 10 to 20% higher than the more accurate method of cross-sectioning.

An example of the measured distance method for calculating ripper production is:

*Data* — D10T2 — No. 10 with one shank.

910 mm (36 in) between passes.

1.6 km/h (1 mph) average speed (including slippage and stalls).

Every 91 m (300 ft) requires 0.25 min to raise, pivot, turn, and lower again: 91 m (300 ft) = 1 pass.

610 mm (24 in) penetration.

Full time ripping (no pushing or dozing assignment).



Example of Estimating Production (Metric)

Time per pass:

1.6 km/h = 26.7 m/min. Then  $\frac{91 \text{ m}}{26.7 \text{ m/min}} = 3.41 \text{ min};$

3.41 min + 0.25 min (turn time) = 3.66 min/pass.

If the operator works an average of 45 min per h, it is possible to make  $= \frac{45}{3.66} = 12.3 \text{ passes per h}$

Volume ripped:  $91 \text{ m} \times 0.9 \text{ m} \times 0.6 \text{ m} = 49.1 \text{ BCM}$  per pass

Production =  $49.1 \times 12.3 = 604 \text{ BCM per h}$

Remember the results from this method are usually 10 to 20 per cent higher than the actual production that can be expected on the job.

Example of Estimating Production (English)

Time per pass:

MPH = 88 fpm. Then  $\frac{300 \text{ ft}}{88 \text{ fpm}} = 3.41 \text{ min};$

3.41 min + 0.25 min. (turn time) = 3.66 min/pass.

If the operator works an average of 45 min per h, it is possible to make  $= \frac{45}{3.66} = 12.3 \text{ passes per h}$

Volume ripped:  $\frac{300 \times 3 \times 2}{27} = 66.7 \text{ BCY per pass}$

Production =  $66.7 \times 12.3 = 820 \text{ BCY per hr}$



**NOTE:** The demands of heavy ripping will increase the normal owning and operating costs of the tractor.

These costs should be increased no less than 30-40% in heavy ripping applications to estimate rock loosening costs.

There is no ready answer or rule-of-thumb solution to predict ripping production. Even if everything is known about the seismic velocity of the material, its composition, job conditions, equipment and operator, only a "guesstimate" can be given. The final answer must come from a production study obtained on the job site.

Sample problem (Metric)

Determine the loosening costs in the following situation:

Machine	— D10T2 Tractor with No. 10 Single Shank Ripper
Rip Spacing	— 915 mm
Ripper Penetration	— 610 mm
Rip Distance	— 91 m
Rip Time	— 3.41 minutes
Maneuver Time	— 0.25 minutes
Seismic Velocity	— 1830 meters per second
Assume	60 min. hour

*Solution:*

1. Total Cycle Time =  $3.41 + 0.25 = 3.66 \text{ min}$

$$\text{Cycles/hour} = \frac{60 \text{ min/hr}}{3.66 \text{ min/cycle}} = 16.4$$

2. Production per cycle =  $91 \text{ m} \times 0.9 \text{ m} \times 0.6 \text{ m} = 49.1 \text{ BCM/cycle}$

3. Production =  $49.1 \text{ BCM/cycle} \times 16.4 \text{ cycles/h} = 805 \text{ BCM/h}$

4. Remember results of this method are usually 10 to 20% high.

$$\begin{aligned} \text{Actual Production} &= 80\% \text{ of } 805 \text{ BCM/h} \\ &= 644 \text{ BCM/h} \end{aligned}$$

$$\text{Or } 90\% \text{ of } 805 \text{ BCM/h} = 725 \text{ BCM/h}$$

5. Owning and Operating Costs

A D10T2 (ripping only) could have a \$115.00/h O & O costs including \$30/h operator.

6. Loosening Costs

$$\$115.00/\text{hr} \div 644 \text{ BCM/h} = \$0.179/\text{BCM}$$

$$\$115.00/\text{hr} \div 725 \text{ BCM/h} = \$0.159/\text{BCM}$$

The loosening cost should range from 15.9¢ to 17.9¢/BCM

Sample problem (English)

Determine the loosening costs in the following situation:

Machine	— D10T2 Tractor with No. 10 Single Shank Ripper
Rip Spacing	— 3 feet
Ripper Penetration	— 2 feet
Rip Distance	— 300 feet
Rip Time	— 3.41 minutes
Maneuver Time	— 0.25 minutes
Seismic Velocity	— 6000 feet per second
Assume	60 min. hour

*Solution:*

1. Total Cycle Time =  $3.41 + 0.25 = 3.66$  min  

$$\text{Cycles/hour} = \frac{60 \text{ min/hr}}{3.66 \text{ min/cycle}} = 16.4$$
2. Production per cycle =  $\frac{300 \times 3 \times 2}{27} = 66.7$  BCY/cycle
3. Production =  $66.7 \text{ BCY/cycle} \times 16.4 \text{ cycles/hr} = 1094 \text{ BCY/hour}$
4. Remember results of this method are usually 10 to 20% high.  

$$\begin{aligned} \text{Actual Production} &= 80\% \times 1094 \\ &= 875 \text{ BCY/hr} \\ \text{or } 90\% \times 1094 &= 984 \text{ BCY/hr} \end{aligned}$$
5. Owning and Operating Costs  
 A D10T2 (ripping only) could have a \$115.00/hr  
 O & O costs including \$30/hr operator
6. Loosening Costs  

$$\begin{aligned} \$115.00/\text{hr} \div 875 \text{ BCY/hr} &= \$0.131/\text{BCY} \\ \$115.00/\text{hr} \div 984 \text{ BCY/hr} &= \$0.117/\text{BCY} \end{aligned}$$
 The loosening cost should range from 11.7¢ to 13.1¢/BCY



## USE OF SEISMIC VELOCITY CHARTS

The charts of ripper performance estimated by seismic wave velocities have been developed from field tests conducted in a variety of materials. Considering the extreme variations among materials and even among rocks of a specific classification, the charts must be recognized as being at best only one indicator of rippability.

Accordingly, consider the following precautions when evaluating the feasibility of ripping a given formation:

- Tooth penetration is often the key to ripping success, regardless of seismic velocity. This is particularly true in homogeneous materials such as mudstones and claystones and the fine-grained caliches. It is also true in tightly cemented formations such as conglomerates, some glacial tills and caliches containing rock fragments.

- Low seismic velocities of sedimentaries can indicate probable rippability. However, if the fractures and bedding joints do not allow tooth penetration, the material may not be ripped effectively.
- Pre-blasting or “popping” may induce sufficient fracturing to permit tooth entry, particularly in the caliches, conglomerates and some other rocks; but the economics should be checked carefully when considering popping in the higher grades of sandstones, limestones and granites.

Ripping is still more art than science, and much will depend on operator skill and experience. Ripping for scraper loading may call for different techniques than if the same material is to be dozed away. Cross-ripping requires a change in approach. The number of shanks used, length and depth of shank, tooth angle, direction, throttle position — all must be adjusted according to field conditions. Ripping success may well depend on the operator finding the proper combination for those conditions.

**D8R/D8T**

● Multi- or Single Shank No. 8 Ripper

● Estimated by Seismic Wave Velocities

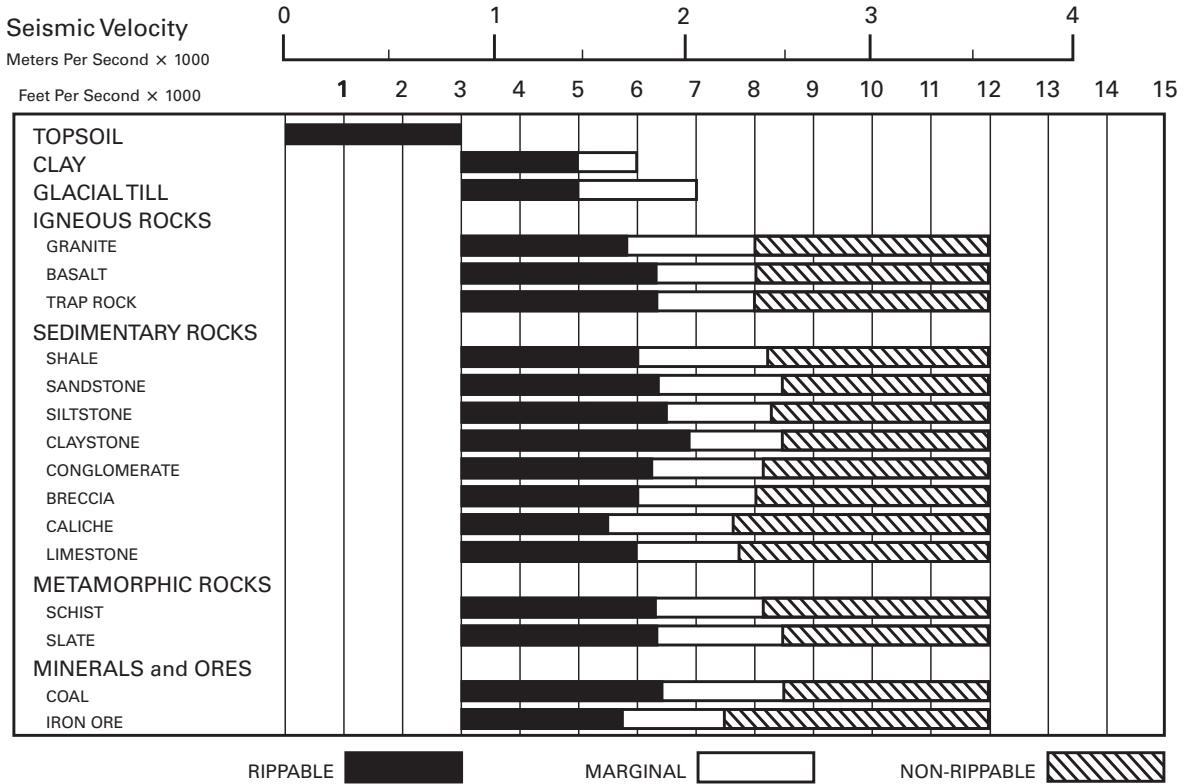

**D9R/D9T**

- Multi- or Single Shank No. 9 Ripper
- Estimated by Seismic Wave Velocities

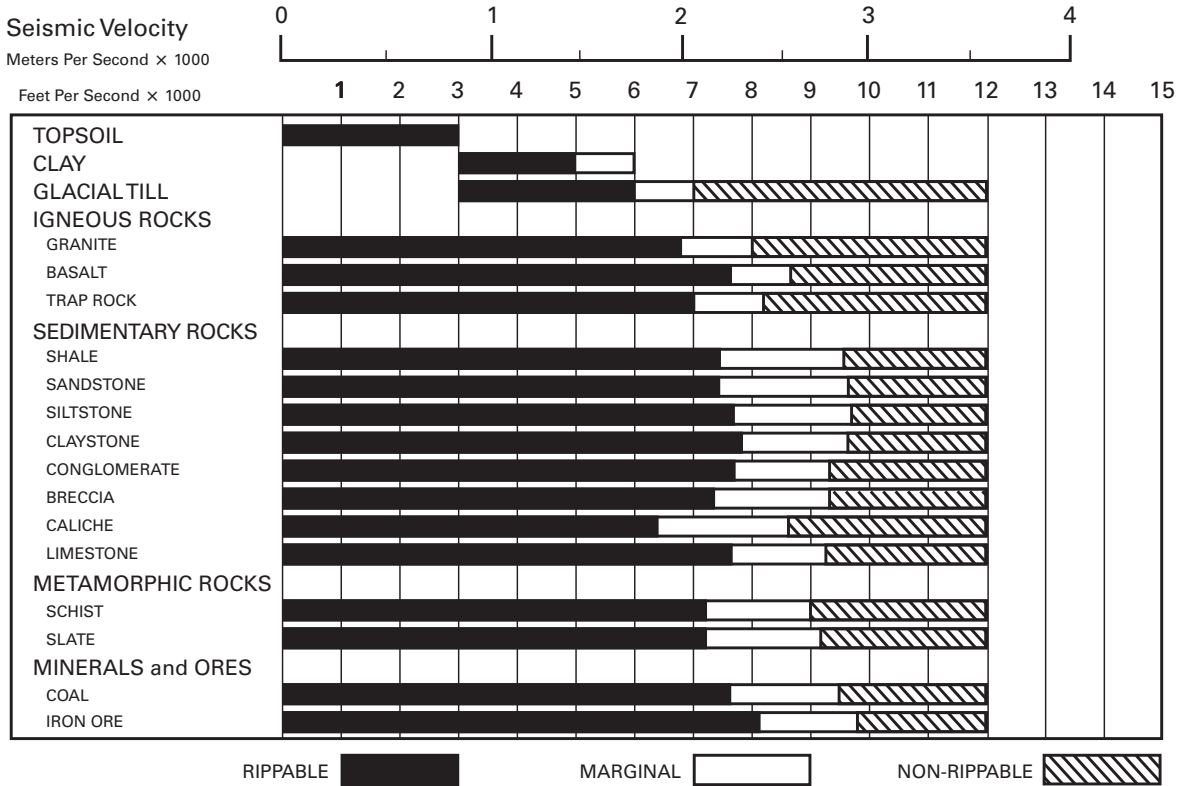

**D10T2**

● Multi- or Single Shank No. 10 Ripper

● Estimated by Seismic Wave Velocities

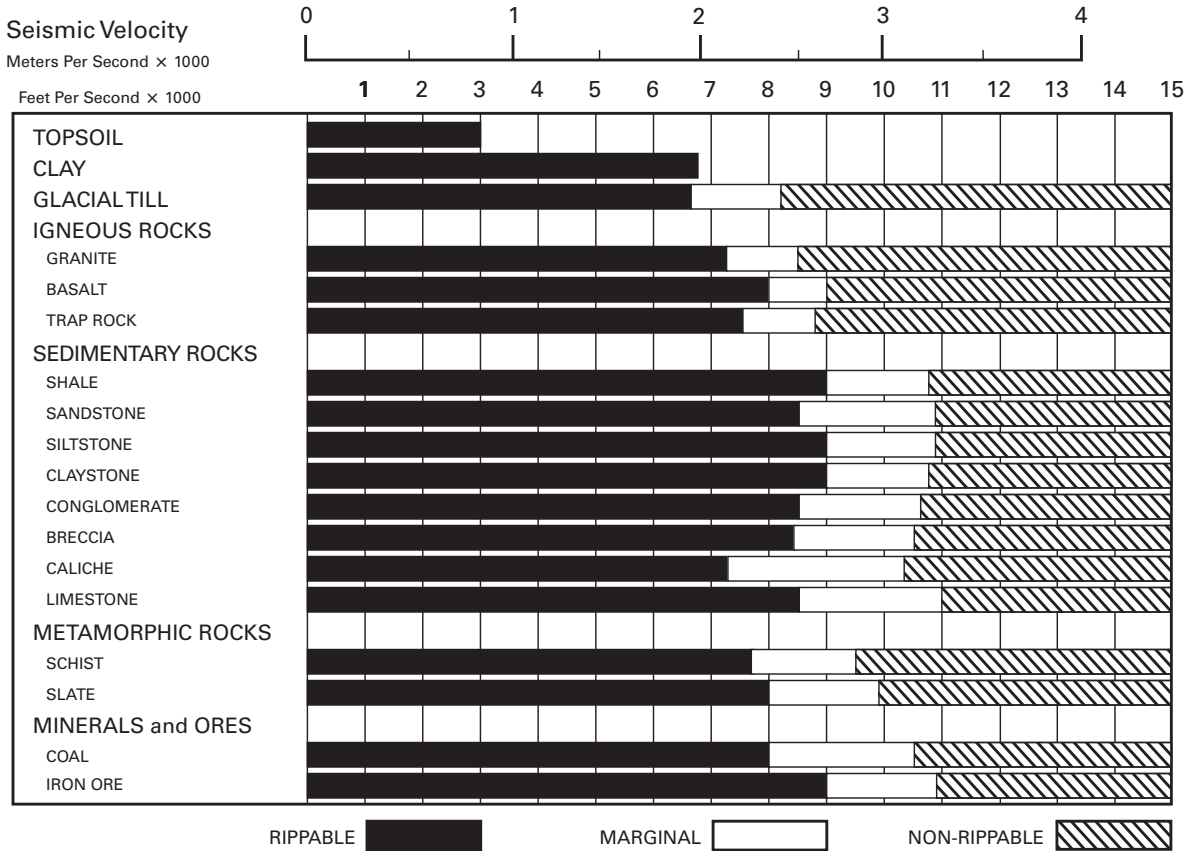

**D11T**

- Multi- or Single Shank No. 11 Ripper
- Estimated by Seismic Wave Velocities

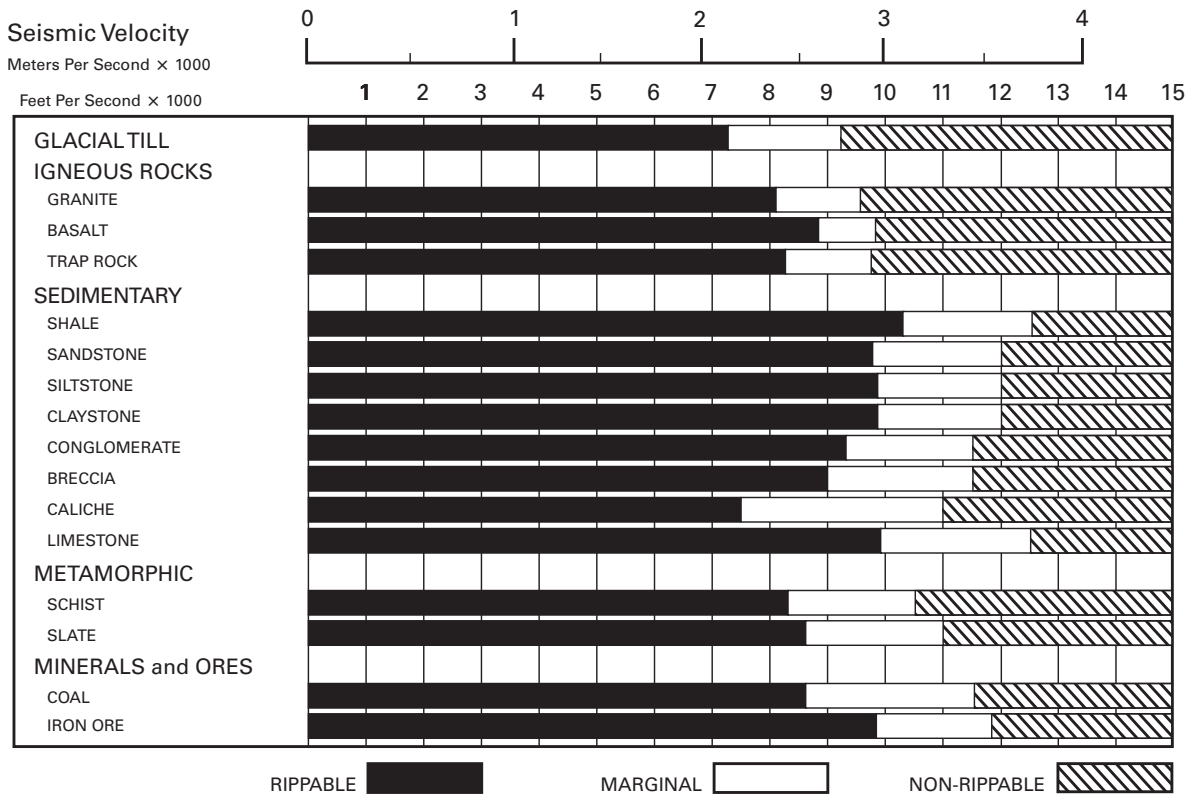

**D11T CD**

● **Single Shank No. 11 Ripper**

● **Estimated by Seismic Wave Velocities**

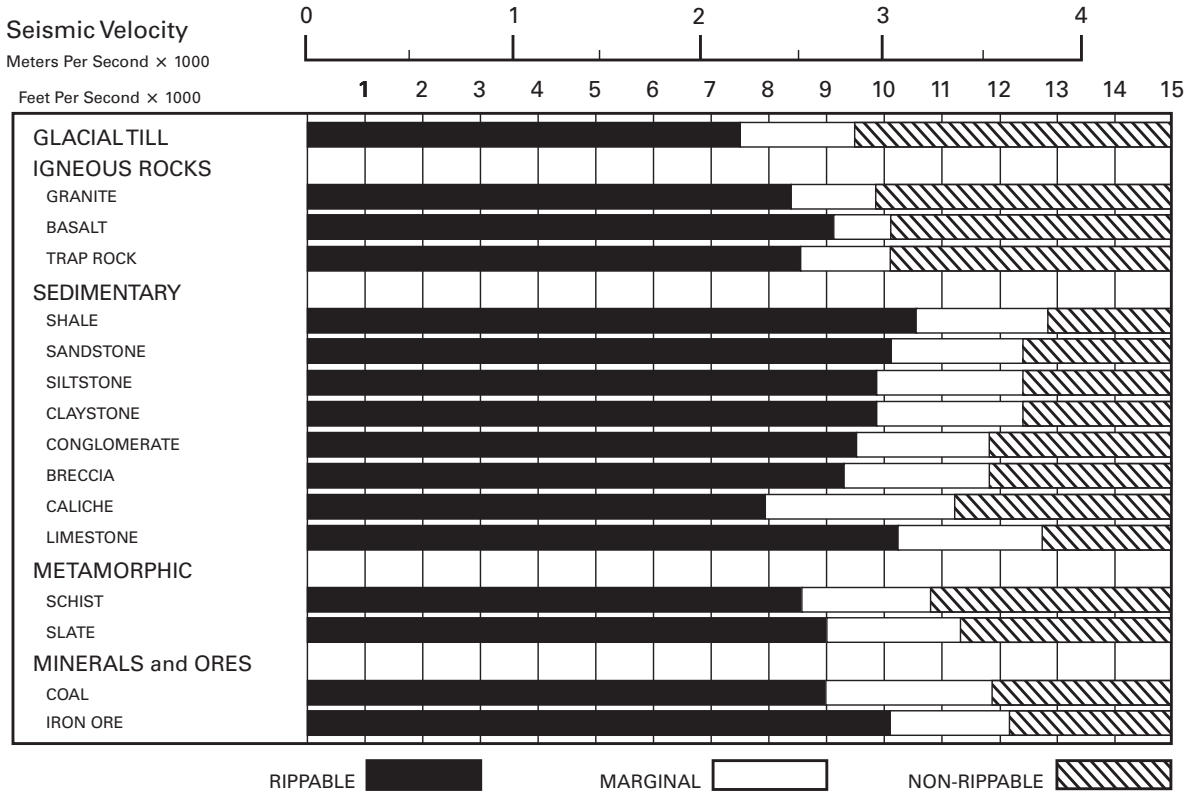

**CONSIDERATIONS FOR USING PRODUCTION ESTIMATED GRAPHS:**

- Machine rips full-time — no dozing.
- Power shift tractors with single shank rippers.
- 100% efficiency (60 min hour).
- Charts are for all classes of material.
- In igneous rock with seismic velocity of 8000 fps (2450 mps) or higher for the D11T, and 6000 fps (1830 mps) or higher for the D10T2, D9R/D9T and D8R/D8T, the production figures shown should be reduced by 25%.
- Upper limit of charts reflect ripping under ideal conditions only. If conditions such as thick lamination, vertical lamination or any factor which would adversely affect production are present, the lower limit should be used.

**D8R/D8T WITH SINGLE SHANK**

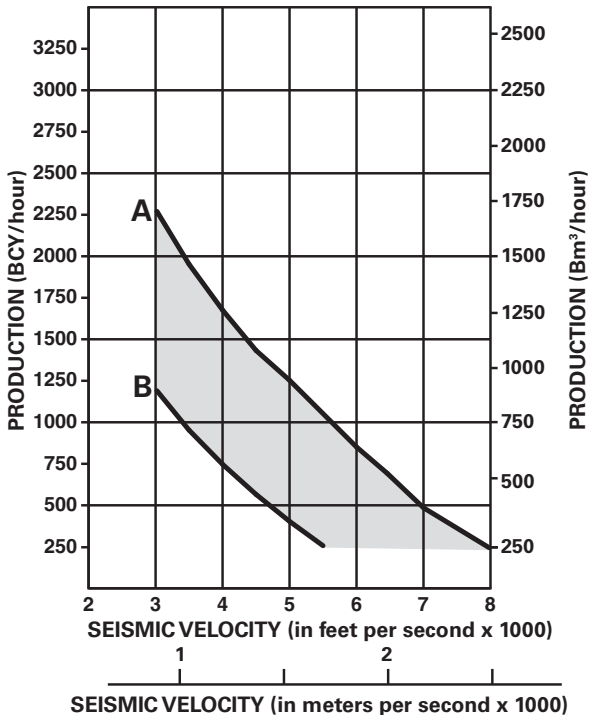

**D9R/D9T WITH SINGLE SHANK**

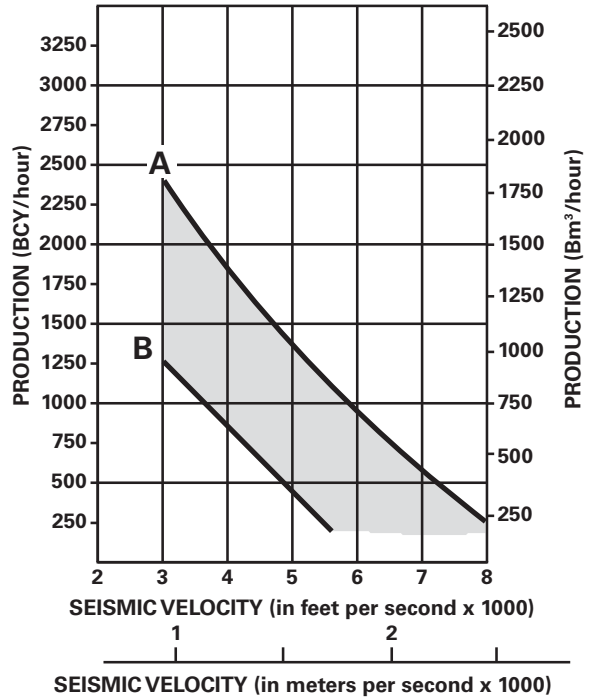

**KEY**

- A — IDEAL
- B — ADVERSE



# Rippers

## Estimated Ripper Production Graphs

● D10T2 ● D11T ● ● D11T CD

**D10T2 WITH SINGLE SHANK**

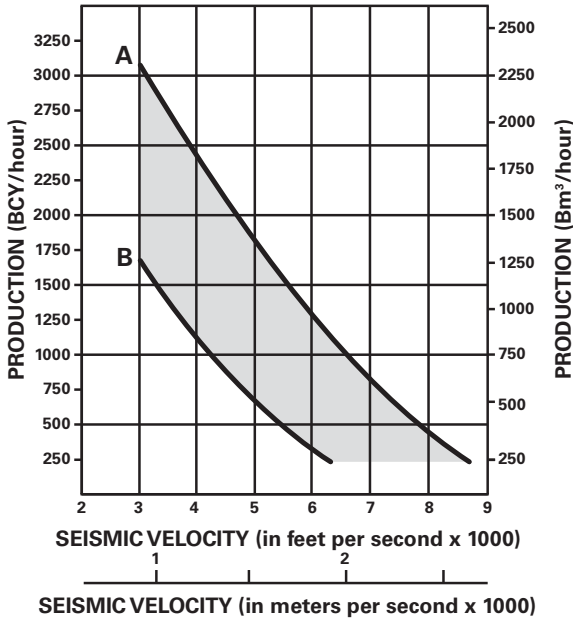

**D11T WITH SINGLE SHANK**

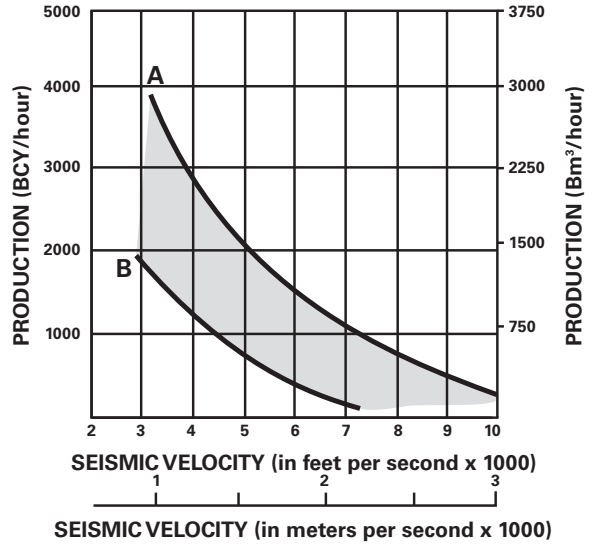

**D11T CD WITH SINGLE SHANK**

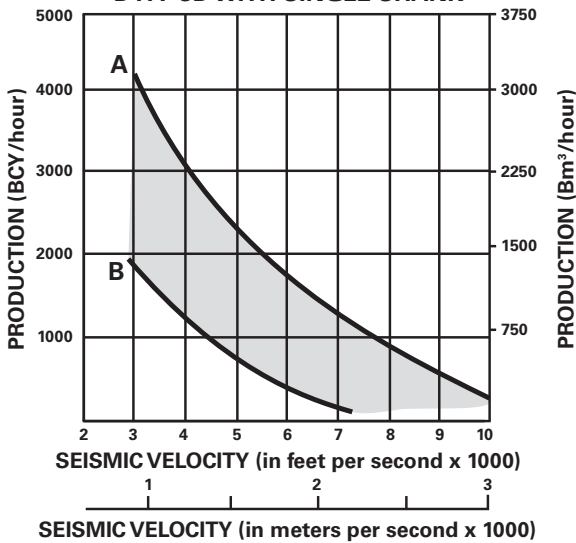

### KEY

A — IDEAL  
B — ADVERSE

# WINCHES PACCAR ALLIED

## CONTENTS

### PACCAR

Features . . . . .	19-84
Physical Specifications . . . . .	19-85
Operating Specifications . . . . .	19-95

### Allied

Features . . . . .	19-99
Physical Specifications . . . . .	19-100
Operating Specifications . . . . .	19-107

**PACCAR Features:**

PACCAR winches have been installed on Cat tractors since 1932. After acquiring the intellectual and property rights of Cat tail winches in the early 1990's, PACCAR Winch has exclusively supplied Caterpillar manufacturing facilities worldwide with tractor winches for factory installation.

**PA40 and PA50**

- **Closed loop hydrostatic operation** with variable displacement motor and dedicated variable displacement pump for maximum winching power and flexibility.
- **Infinitely variable control** of line speed and line pull including positive inching control at maximum rated line pull.
- **Standard full-function “power-in” and “power-out” control.** This is optional on some competitive winches.
- **Standard “drive-away”** to maintain tension on the cable when driving the tractor away from a stationary load.
- **Standard “free spool”** to allow cable to be pulled off the winch by hand.
- **Durable cast winch case** with fairlead mounting lugs, log arch mounting lugs, and heavy duty drawbar.

**PA55, PA56 and PA80**

- **PTO mechanical winch drive** with full tractor engine power available to the winch.
- **Self-contained internal hydraulic control system** for easy installation.
- **Equal speed gearing in “reel-in” and “reel-out”** to provide smooth and predictable performance.
- **Standard “drive-away”** to maintain tension on the cable when driving the tractor away from a stationary load.
- **Standard “free spool”** to allow cable to be pulled off the winch by hand.
- **Durable cast winch case** with fairlead mounting lugs, log arch mounting lugs, and heavy duty drawbar.

**PA90, PA110B, PA140 and H200**

- **Hydraulically driven winch** for infinitely variable control of line speed and line pull including positive inching control at maximum rated line pull.
- **Optimized “high power” hydraulic control system** including specialized directional control valve for maximum winching power and flexibility.
- **Dual braking system** provides a static brake with sprag clutch to eliminate fall-back and a hydraulic brake valve for dynamic braking.
- **Single lever joystick control** for ease of operation.
- **Fabricated steel winch case** with integral heavy duty drawbar provides excellent durability and easy weldability.
- **Standard three-roller fairlead** for improved wire rope life during side pulls.

**H60, H110B and H140**

- **Hydraulically driven winch** for infinitely variable control of line speed and line pull including positive inching control at maximum rated line pull.
- **Standard Cat ripper control system** is employed for winch “power-in” and “power-out” functions.
- **Winch installation time is reduced by up to 70%** compared to “high power” installations.
- **Easy field interchangeability between winch and ripper.**
- **Dual braking system** provides a static brake with sprag clutch to eliminate fall-back and a hydraulic brake valve for dynamic braking.
- **Durable cast (H60) or fabricated steel (H110B and H140) winch case** with integral heavy duty drawbar.
- **Three-roller fairlead** for improved wire rope life during side pulls is standard on H110B and H140 and optional on H60.
- **“Free spool”** to allow cable to be pulled off the winch by hand is standard on H60.

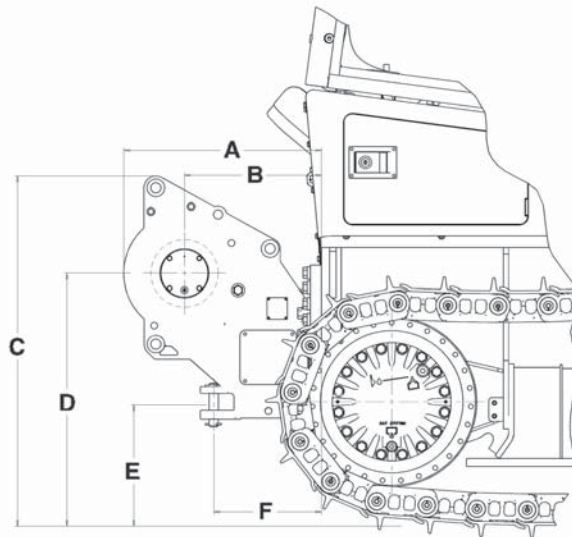

WINCH MODEL TRACTOR MODEL	PA40				PA50	
	D3K2, D4K2, D5K2 <sup>5</sup>		D3K2, D4K2, D5K2		D6K2	
Tractor transmission	Hydrostatic		Hydrostatic		Hydrostatic	
Winch drive	Hydrostatic		Hydrostatic		Hydrostatic	
A Tractor to rear of winch	751 mm	29.6"	751 mm	29.6"	845 mm	33.2"
B Tractor to drum centerline	521 mm	20.5"	521 mm	20.5"	615 mm	24.2"
C Ground to top of winch	1327 mm	52.2"	1327 mm	52.2"	1380 mm	54.4"
D Ground to drum centerline	959 mm	37.8"	959 mm	37.8"	1010 mm	39.8"
E Ground to center of hitch	473 mm	18.6"	473 mm	18.6"	525 mm	20.7"
F Tractor to drawbar pin centerline	410 mm	16.1"	410 mm	16.1"	505 mm	19.8"
Winch width (not shown) <sup>1</sup>	740 mm	29.2"	740 mm	29.2"	740 mm	29.2"
Drum diameter (not shown)	255 mm	10.0"	255 mm	10.0"	205 mm	8.0"
Weight <sup>2</sup>	610 kg	1345 lb	610 kg	1345 lb	610 kg	1345 lb
Oil refill capacity	4.3 L	4.5 qt	4.3 L	4.5 qt	4.3 L	4.5 qt
Wire rope diameter:						
Recommended	16 mm	0.63"	16 mm	0.63"	19 mm	0.75"
Optional	19 mm	0.75"	19 mm	0.75"	22 mm	0.88"
Maximum theoretical drum capacity: <sup>3</sup>						
Recommended rope	114 m	374'	114 m	374'	93 m	306'
Optional rope	80 m	264'	80 m	264'	67 m	220'
Maximum recommended drum capacity: <sup>4</sup>						
Recommended rope	83 m	272'	83 m	272'	62 m	203'
Optional rope	55 m	180'	55 m	180'	56 m	183'
Wire rope ferrule size (OD)	54 mm	2.13"	54 mm	2.13"	54 mm	2.13"
Wire rope ferrule size (length)	67 mm	2.63"	67 mm	2.63"	67 mm	2.63"

<sup>1</sup>Width does not include mounting brackets/adapters (if any).

<sup>2</sup>Weight shown is base winch only. Does not include mounting arrangement, control arrangement, oil, or wire rope.

<sup>3</sup>Per SAE J1158.

<sup>4</sup>Per SAE J706 (K=,9).

<sup>5</sup>Meets Tier 3/Stage IIIA/Japan 2006 (Tier 3) equivalent emission standards.

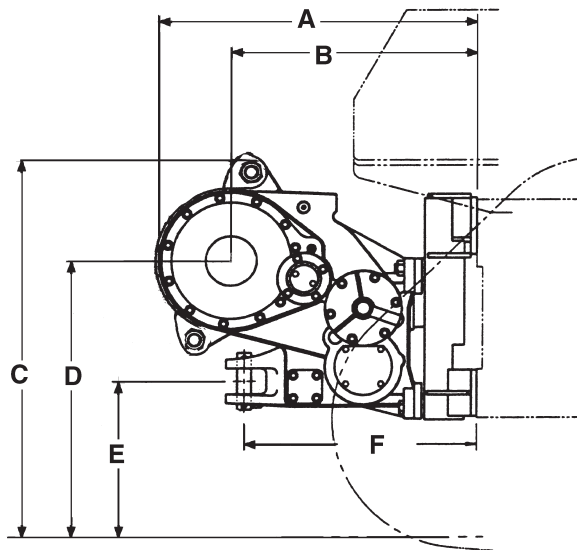

<b>WINCH MODEL</b>	<b>PA55</b>			
<b>TRACTOR MODEL</b>	<b>D5R XL, D6N XL</b>		<b>D5R LGP, D6N LGP</b>	
Tractor transmission	<b>Powershift</b>		<b>Powershift</b>	
Winch drive	<b>PTO</b>		<b>PTO</b>	
<b>A</b> Tractor to rear of winch	1145 mm	<b>45.1"</b>	1145 mm	<b>45.1"</b>
<b>B</b> Tractor to drum centerline	890 mm	<b>35.1"</b>	890 mm	<b>35.1"</b>
<b>C</b> Ground to top of winch	1330 mm	<b>52.3"</b>	1380 mm	<b>54.3"</b>
<b>D</b> Ground to drum centerline	960 mm	<b>37.8"</b>	1010 mm	<b>39.8"</b>
<b>E</b> Ground to center of hitch	525 mm	<b>20.7"</b>	575 mm	<b>22.7"</b>
<b>F</b> Tractor to drawbar pin centerline	845 mm	<b>33.2"</b>	845 mm	<b>33.2"</b>
Winch width (not shown) <sup>1</sup>	975 mm	<b>38.3"</b>	975 mm	<b>38.3"</b>
Drum diameter (not shown)	255 mm	<b>10.0"</b>	255 mm	<b>10.0"</b>
Weight <sup>2</sup>	1180 kg	<b>2600 lb</b>	1180 kg	<b>2600 lb</b>
Oil refill capacity	74 L	<b>19.5 U.S. gal</b>	74 L	<b>19.5 U.S. gal</b>
Wire rope diameter:				
Recommended	19 mm	<b>0.75"</b>	19 mm	<b>0.75"</b>
Optional	22 mm	<b>0.88"</b>	22 mm	<b>0.88"</b>
Maximum theoretical drum capacity: <sup>3</sup>				
Recommended rope	119 m	<b>391'</b>	119 m	<b>391'</b>
Optional rope	85 m	<b>281'</b>	85 m	<b>281'</b>
Maximum recommended drum capacity: <sup>4</sup>				
Recommended rope	81 m	<b>267'</b>	81 m	<b>267'</b>
Optional rope	55 m	<b>180'</b>	55 m	<b>180'</b>
Wire rope ferrule size (OD)	54 mm	<b>2.13"</b>	54 mm	<b>2.13"</b>
Wire rope ferrule size (length)	67 mm	<b>2.63"</b>	67 mm	<b>2.63"</b>

<sup>1</sup>Width does not include mounting brackets/adapters (if any).

<sup>2</sup>Weight shown is base winch only. Does not include mounting arrangement, control arrangement, oil, or wire rope.

<sup>3</sup>Per SAE J1158.

<sup>4</sup>Per SAE J706 (K=9).

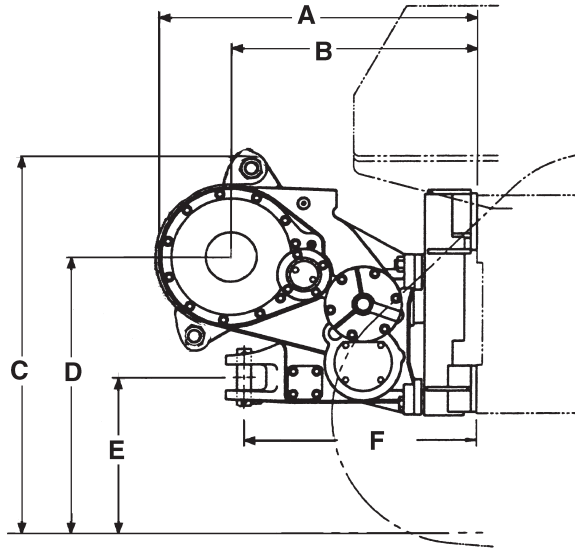

WINCH MODEL	H60			
	D5R XL, D6N XL		D5R LGP, D6N LGP	
TRACTOR MODEL	Powershift		Powershift	
Tractor transmission	Hydraulic (Ripper)		Hydraulic (Ripper)	
Winch drive	Hydraulic (Ripper)		Hydraulic (Ripper)	
A Tractor to rear of winch	1210 mm	47.7"	1210 mm	47.7"
B Tractor to drum centerline	945 mm	37.7"	945 mm	37.7"
C Ground to top of winch	1530 mm	60.2"	1640 mm	64.7"
D Ground to drum centerline	1160 mm	45.7"	1275 mm	50.2"
E Ground to center of hitch	725 mm	28.5"	762 mm	33.0"
F Tractor to drawbar pin centerline	910 mm	35.8"	910 mm	35.8"
Winch width (not shown) <sup>1</sup>	975 mm	38.3"	975 mm	38.3"
Drum diameter (not shown)	255 mm	10.0"	255 mm	10.0"
Weight <sup>2</sup>	1180 kg	2600 lb	1180 kg	2600 lb
Oil refill capacity	67 L	17.75 U.S. gal	67 L	17.75 U.S. gal
Wire rope diameter:				
Recommended	22 mm	0.88"	22 mm	0.88"
Optional	26 mm	1.0"	26 mm	1.0"
Maximum theoretical drum capacity: <sup>3</sup>				
Recommended rope	85 m	281'	85 m	281'
Optional rope	66 m	218'	66 m	218'
Maximum recommended drum capacity: <sup>4</sup>				
Recommended rope	55 m	180'	55 m	180'
Optional rope	50 m	163'	50 m	163'
Wire rope ferrule size (OD)	54 mm	2.13"	54 mm	2.13"
Wire rope ferrule size (length)	67 mm	2.63"	67 mm	2.63"

<sup>1</sup>Width does not include mounting brackets/adapters (if any).

<sup>2</sup>Weight shown is base winch only. Does not include mounting arrangement, control arrangement, oil, or wire rope.

<sup>3</sup>Per SAE J1158.

<sup>4</sup>Per SAE J706 (K=9).

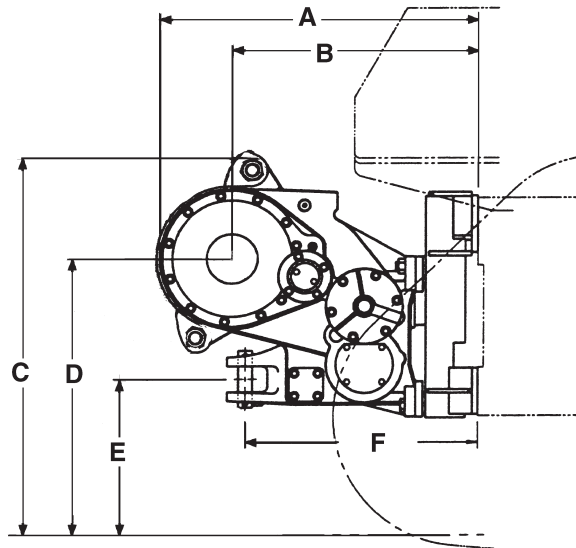

<b>WINCH MODEL</b>	<b>PA56</b>			
<b>TRACTOR MODEL</b>	<b>D6R, D6R XL, D6T, D6T<sup>5</sup> XL, XL VPAT, XW</b>		<b>D6R LGP, D6T<sup>5</sup> XW VPAT, LGP, and LGP VPAT</b>	
Tractor transmission	<b>Powershift</b>		<b>Powershift</b>	
Winch drive	<b>PTO</b>		<b>PTO</b>	
<b>A</b> Tractor to rear of winch	1210 mm	<b>47.7"</b>	1210 mm	<b>47.7"</b>
<b>B</b> Tractor to drum centerline	945 mm	<b>37.7"</b>	945 mm	<b>37.7"</b>
<b>C</b> Ground to top of winch	1530 mm	<b>60.2"</b>	1580 mm	<b>62.2"</b>
<b>D</b> Ground to drum centerline	1160 mm	<b>45.7"</b>	1210 mm	<b>47.7"</b>
<b>E</b> Ground to center of hitch	725 mm	<b>28.5"</b>	775 mm	<b>30.5"</b>
<b>F</b> Tractor to drawbar pin centerline	910 mm	<b>35.8"</b>	910 mm	<b>35.8"</b>
Winch width (not shown) <sup>1</sup>	975 mm	<b>38.3"</b>	975 mm	<b>38.3"</b>
Drum diameter (not shown)	255 mm	<b>10.0"</b>	255 mm	<b>10.0"</b>
Weight <sup>2</sup>	1180 kg	<b>2600 lb</b>	1180 kg	<b>2600 lb</b>
Oil refill capacity	67 L	<b>17.75 U.S. gal</b>	67 L	<b>17.75 U.S. gal</b>
Wire rope diameter:				
Recommended	22 mm	<b>0.88"</b>	22 mm	<b>0.88"</b>
Optional	26 mm	<b>1.0"</b>	26 mm	<b>1.0"</b>
Maximum theoretical drum capacity: <sup>3</sup>				
Recommended rope	85 m	<b>281'</b>	85 m	<b>281'</b>
Optional rope	66 m	<b>218'</b>	66 m	<b>218'</b>
Maximum recommended drum capacity: <sup>4</sup>				
Recommended rope	55 m	<b>180'</b>	55 m	<b>180'</b>
Optional rope	50 m	<b>163'</b>	50 m	<b>163'</b>
Wire rope ferrule size (OD)	54 mm	<b>2.13"</b>	54 mm	<b>2.13"</b>
Wire rope ferrule size (length)	67 mm	<b>2.63"</b>	67 mm	<b>2.63"</b>

<sup>1</sup>Width does not include mounting brackets/adapters (if any).

<sup>2</sup>Weight shown is base winch only. Does not include mounting arrangement, control arrangement, oil, or wire rope.

<sup>3</sup>Per SAE J1158.

<sup>4</sup>Per SAE J706 (K=,9).

<sup>5</sup>Meets Tier 4 Final/Stage IV/Japan 2014 (Tier 4 Final) emission standards.

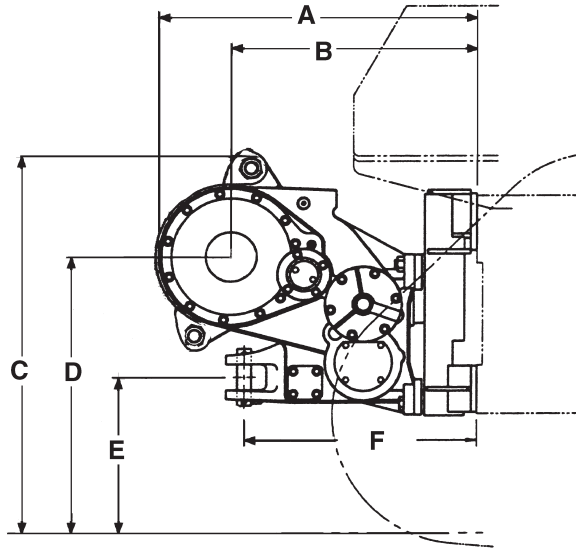

WINCH MODEL TRACTOR MODEL	H85			
	D6T <sup>5</sup> XL, XL VPAT, and XW Powershift Hydraulic (Ripper)		D6T <sup>5</sup> XW VPAT, LGP, and LGP VPAT Powershift Hydraulic (Ripper)	
Tractor transmission				
Winch drive				
A Tractor to rear of winch	1210 mm	47.7"	1210 mm	47.7"
B Tractor to drum centerline	945 mm	37.7"	945 mm	37.7"
C Ground to top of winch	1530 mm	60.2"	1580 mm	62.2"
D Ground to drum centerline	1160 mm	45.7"	1210 mm	47.7"
E Ground to center of hitch	725 mm	28.5"	775 mm	30.5"
F Tractor to drawbar pin centerline	910 mm	35.8"	910 mm	35.8"
Winch width (not shown) <sup>1</sup>	975 mm	38.3"	975 mm	38.3"
Drum diameter (not shown)	255 mm	10.0"	255 mm	10.0"
Weight <sup>2</sup>	1180 kg	2600 lb	1180 kg	2600 lb
Oil refill capacity	67 L	17.75 U.S. gal	67 L	17.75 U.S. gal
Wire rope diameter:				
Recommended	22 mm	0.88"	22 mm	0.88"
Optional	26 mm	1.0"	26 mm	1.0"
Maximum theoretical drum capacity: <sup>3</sup>				
Recommended rope	85 m	281'	85 m	281'
Optional rope	66 m	218'	66 m	218'
Maximum recommended drum capacity: <sup>4</sup>				
Recommended rope	55 m	180'	55 m	180'
Optional rope	50 m	163'	50 m	163'
Wire rope ferrule size (OD)	54 mm	2.13"	54 mm	2.13"
Wire rope ferrule size (length)	67 mm	2.63"	67 mm	2.63"

<sup>1</sup>Width does not include mounting brackets/adapters (if any).

<sup>2</sup>Weight shown is base winch only. Does not include mounting arrangement, control arrangement, oil, or wire rope.

<sup>3</sup>Per SAE J1158.

<sup>4</sup>Per SAE J706 (K=,9).

<sup>5</sup>Meets Tier 4 Final/Stage IV/Japan 2014 (Tier 4 Final) emission standards.



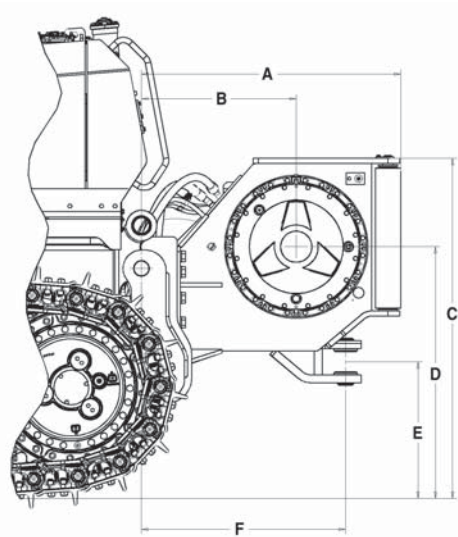

<b>WINCH MODEL</b>	<b>PA90</b>		<b>H110B</b>	
<b>TRACTOR MODEL</b>	<b>D7E</b>		<b>D7E</b>	
Tractor transmission	<b>Electric</b>		<b>Electric</b>	
Winch drive	<b>Hydraulic</b>		<b>Hydraulic</b>	
<b>A</b> Tractor to rear of winch	1265 mm	<b>49.8"</b>	1265 mm	<b>4'8.5"</b>
<b>B</b> Tractor to drum centerline	755 mm	<b>29.7"</b>	755 mm	<b>3'0.4"</b>
<b>C</b> Ground to top of winch	1665 mm	<b>65.6"</b>	1665 mm	<b>5'6.8"</b>
<b>D</b> Ground to drum centerline	1235 mm	<b>48.5"</b>	1235 mm	<b>4'1.5"</b>
<b>E</b> Ground to center of hitch	670 mm	<b>26.3"</b>	670 mm	<b>2'3.8"</b>
<b>F</b> Tractor to drawbar pin centerline	995 mm	<b>39.2"</b>	995 mm	<b>4'0"</b>
Winch width (not shown) <sup>1</sup>	1090 mm	<b>43.0"</b>	1160 mm	<b>3'9.6"</b>
Drum diameter (not shown)	320 mm	<b>12.5"</b>	320 mm	<b>1'0.5"</b>
Weight <sup>2</sup>	1520 kg	<b>3350 lb</b>	1790 kg	<b>3950 lb</b>
Oil refill capacity	12 L	<b>12.5 qt</b>	15 L	<b>4 U.S. gal</b>
Wire rope diameter:				
Recommended	26 mm	<b>1"</b>	28 mm	<b>1.13"</b>
Optional	28 mm	<b>1.13"</b>	32 mm	<b>1.25"</b>
Maximum theoretical drum capacity: <sup>3</sup>				
Recommended rope	68 m	<b>223'</b>	78 m	<b>257'</b>
Optional rope	54 m	<b>178'</b>	62 m	<b>204'</b>
Maximum recommended drum capacity: <sup>4</sup>				
Recommended rope	56 m	<b>183'</b>	55 m	<b>182'</b>
Optional rope	38 m	<b>126'</b>	36 m	<b>118'</b>
Wire rope ferrule size (OD)	60 mm	<b>2.38"</b>	60 mm	<b>2.38"</b>
Wire rope ferrule size (length)	70 mm	<b>2.75"</b>	70 mm	<b>2.75"</b>

<sup>1</sup>Width does not include mounting brackets/adapters (if any).

<sup>2</sup>Weight shown is base winch only. Does not include mounting arrangement, control arrangement, oil, or wire rope.

<sup>3</sup>Per SAE J1158.

<sup>4</sup>Per SAE J706 (K=.9).

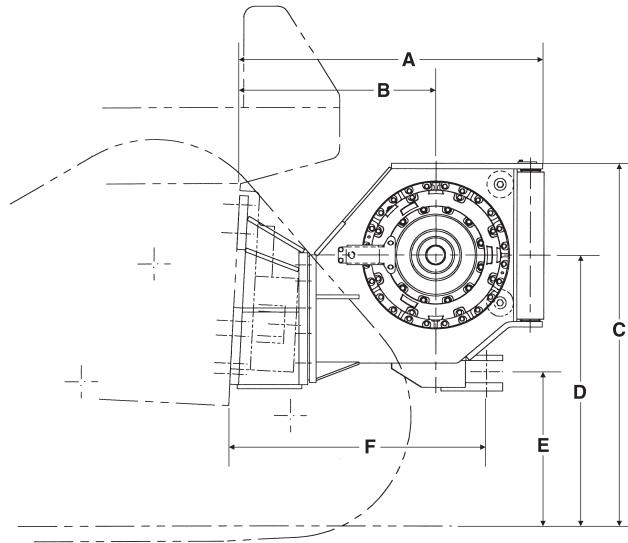

WINCH MODEL	PA90				H110B	
	D6R, D6T <sup>5</sup> XW VPAT		D6T <sup>5</sup> LGP and LGP VPAT		D6T	
Tractor transmission	Powershift		Powershift		Powershift	
Winch drive	Hydraulic (High Power)		Hydraulic (High Power)		Hydraulic (High Power)	
<b>A</b> Tractor to rear of winch	1380 mm	4'6"	1380 mm	4'6"	1380 mm	4'6"
<b>B</b> Tractor to drum centerline	870 mm	2'10"	870 mm	2'10"	870 mm	2'10"
<b>C</b> Ground to top of winch	1680 mm	5'6"	1730 mm	5'8"	1730 mm	5'8"
<b>D</b> Ground to drum centerline	1235 mm	4'1"	1285 mm	4'3"	1285 mm	4'3"
<b>E</b> Ground to center of hitch	670 mm	2'2"	720 mm	2'4"	720 mm	2'4"
<b>F</b> Tractor to drawbar pin centerline	1160 mm	3'8"	1160 mm	3'8"	1160 mm	3'8"
Winch width (not shown) <sup>1</sup>	1190 mm	3'7"	1190 mm	3'7"	1190 mm	3'7"
Drum diameter (not shown)	320 mm	1'1"	320 mm	1'1"	320 mm	1'1"
Weight <sup>2</sup>	1500 kg	3300 lb	1500 kg	3300 lb	1790 kg	3950 lb
Oil refill capacity	12 L	3.13 U.S. gal	12 L	3.13 U.S. gal	15 L	4 U.S. gal
Wire rope diameter:						
Recommended	26 mm	1"	26 mm	1"	28 mm	1.13"
Optional	28 mm	1.13"	28 mm	1.13"	32 mm	1.25"
Maximum theoretical drum capacity: <sup>3</sup>						
Recommended rope	69 m	226'	69 m	226'	78 m	257'
Optional rope	55 m	180'	55 m	180'	62 m	204'
Maximum recommended drum capacity: <sup>4</sup>						
Recommended rope	57 m	186'	57 m	186'	55 m	182'
Optional rope	39 m	128'	39 m	128'	36 m	118'
Wire rope ferrule size (OD)	60 mm	2.38"	60 mm	2.38"	60 mm	2.38"
Wire rope ferrule size (length)	70 mm	2.75"	70 mm	2.75"	70 mm	2.75"

<sup>1</sup>Width does not include mounting brackets/adapters (if any).

<sup>2</sup>Weight shown is base winch only. Does not include mounting arrangement, control arrangement, oil, or wire rope.

<sup>3</sup>Per SAE J1158.

<sup>4</sup>Per SAE J706 (K=,9).

<sup>5</sup>Meets Tier 3/Stage IIIA/Japan 2006 (Tier 3) equivalent emission standards.

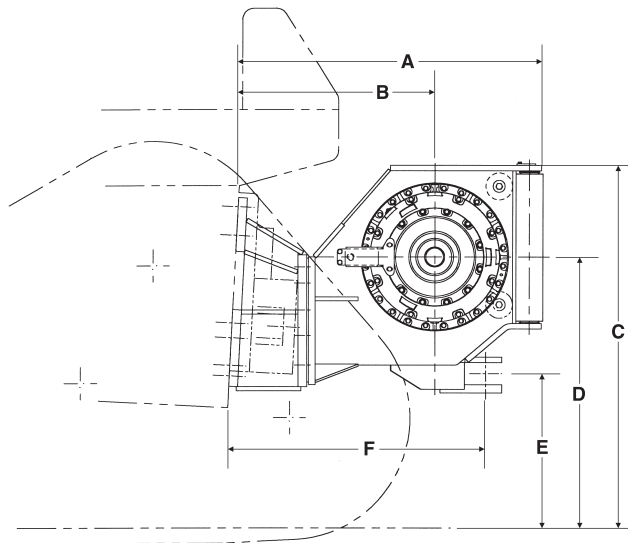

<b>WINCH MODEL</b>	<b>H110B</b>		<b>PA110B</b>	
<b>TRACTOR MODEL</b>	<b>D7R</b>		<b>D7R</b>	
Tractor transmission	<b>Powershift</b>		<b>Powershift</b>	
Winch drive	<b>Hydraulic (Ripper)</b>		<b>Hydraulic (High Power)</b>	
<b>A</b> Tractor to rear of winch	1585 mm	<b>5'2.4"</b>	1435 mm	<b>4'8.5"</b>
<b>B</b> Tractor to drum centerline	1075 mm	<b>3'6.3"</b>	925 mm	<b>3'0.4"</b>
<b>C</b> Ground to top of winch	1695 mm	<b>5'6.8"</b>	1695 mm	<b>5'6.8"</b>
<b>D</b> Ground to drum centerline	1255 mm	<b>4'1.5"</b>	1255 mm	<b>4'1.5"</b>
<b>E</b> Ground to center of hitch	705 mm	<b>2'3.8"</b>	705 mm	<b>2'3.8"</b>
<b>F</b> Tractor to drawbar pin centerline	1370 mm	<b>4'5.9"</b>	1220 mm	<b>4'0"</b>
Winch width (not shown) <sup>1</sup>	1160 mm	<b>3'9.6"</b>	1160 mm	<b>3'9.6"</b>
Drum diameter (not shown)	320 mm	<b>1'0.5"</b>	320 mm	<b>1'0.5"</b>
Weight <sup>2</sup>	1790 kg	<b>3950 lb</b>	1790 kg	<b>3950 lb</b>
Oil refill capacity	15 L	<b>4 U.S. gal</b>	15 L	<b>4 U.S. gal</b>
Wire rope diameter:				
Recommended	28 mm	<b>1.13"</b>	28 mm	<b>1.13"</b>
Optional	32 mm	<b>1.25"</b>	32 mm	<b>1.25"</b>
Maximum theoretical drum capacity: <sup>3</sup>				
Recommended rope	78 m	<b>257'</b>	78 m	<b>257'</b>
Optional rope	62 m	<b>204'</b>	62 m	<b>204'</b>
Maximum recommended drum capacity: <sup>4</sup>				
Recommended rope	55 m	<b>182'</b>	55 m	<b>182'</b>
Optional rope	36 m	<b>118'</b>	36 m	<b>118'</b>
Wire rope ferrule size (OD)	60 mm	<b>2.38"</b>	60 mm	<b>2.38"</b>
Wire rope ferrule size (length)	70 mm	<b>2.75"</b>	70 mm	<b>2.75"</b>

<sup>1</sup>Width does not include mounting brackets/adapters (if any).

<sup>2</sup>Weight shown is base winch only. Does not include mounting arrangement, control arrangement, oil, or wire rope.

<sup>3</sup>Per SAE J1158.

<sup>4</sup>Per SAE J706 (K=9).

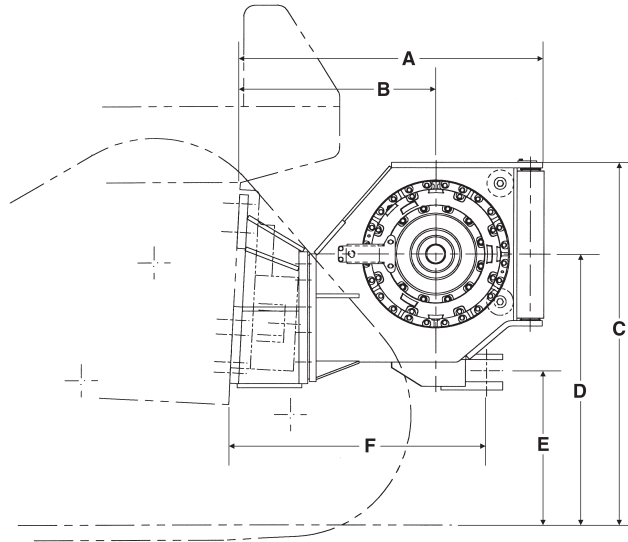

WINCH MODEL TRACTOR MODEL	H140				PA140			
	D8R, D8T		D9R, D9T		D8R, D8T		D9R, D9T	
Tractor transmission	Powershift		Powershift		Powershift		Powershift	
Winch drive	Hydraulic (Ripper)		Hydraulic (Ripper)		Hydraulic (High Power)		Hydraulic (High Power)	
A Tractor to rear of winch	1585 mm	5'2.4"	1525 mm	5'0.3"	1435 mm	4'8.5"	1620 mm	5'3.8"
B Tractor to drum centerline	1075 mm	3'6.3"	1015 mm	3'4.0"	925 mm	3'0.4"	1110 mm	3'7.7"
C Ground to top of winch	1715 mm	5'7.5"	1740 mm	5'8.4"	1715 mm	5'7.5"	1740 mm	5'8.4"
D Ground to drum centerline	1275 mm	4'2.1"	1300 mm	4'3.2"	1275 mm	4'2.1"	1300 mm	4'3.2"
E Ground to center of hitch	725 mm	2'4.5"	750 mm	2'5.5"	725 mm	2'4.5"	750 mm	2'5.5"
F Tractor to drawbar pin centerline	1370 mm	4'5.9"	1255 mm	4'1.5"	1220 mm	4'0"	1350 mm	4'5.2"
Winch width (not shown) <sup>1</sup>	1160 mm	3'9.6"	1160 mm	3'9.6"	1160 mm	3'9.6"	1160 mm	3'9.6"
Drum diameter (not shown)	320 mm	2'0.5"	320 mm	12.5"	320 mm	12.5"	320 mm	12.5"
Weight <sup>2</sup>	1790 kg	3950 lb	1790 kg	3950 lb	1790 kg	3950 lb	1790 kg <sup>5</sup>	3950 lb <sup>5</sup>
Oil refill capacity	15 L	4 U.S. gal	15 L	4 U.S. gal	15 L	4 U.S. gal	15 L	4 U.S. gal
Wire rope diameter:								
Recommended	28 mm	1.13"	28 mm	1.13"	28 mm	1.13"	28 mm	1.13"
Optional	32 mm	1.25"	32 mm	1.25"	32 mm	1.25"	32 mm	1.25"
Maximum theoretical drum capacity: <sup>3</sup>								
Recommended rope	78 m	257'	78 m	257'	78 m	257'	78 m	257'
Optional rope	62 m	204'	62 m	204'	62 m	204'	62 m	204'
Maximum recommended drum capacity: <sup>4</sup>								
Recommended rope	55 m	182'	55 m	182'	55 m	182'	55 m	182'
Optional rope	36 m	118'	36 m	118'	36 m	118'	36 m	118'
Wire rope ferrule size (OD)	60 mm	2.38"	60 mm	2.38"	60 mm	2.38"	60 mm	2.38"
Wire rope ferrule size (length)	70 mm	2.75"	70 mm	2.75"	70 mm	2.75"	70 mm	2.75"

<sup>1</sup>Width does not include mounting brackets/adapters (if any).

<sup>2</sup>Weight shown is base winch only. Does not include mounting arrangement, control arrangement, oil, or wire rope.

<sup>3</sup>Per SAE J1158.

<sup>4</sup>Per SAE J706 (K=9).

<sup>5</sup>3700 kg (8150 lb) with counterweight.

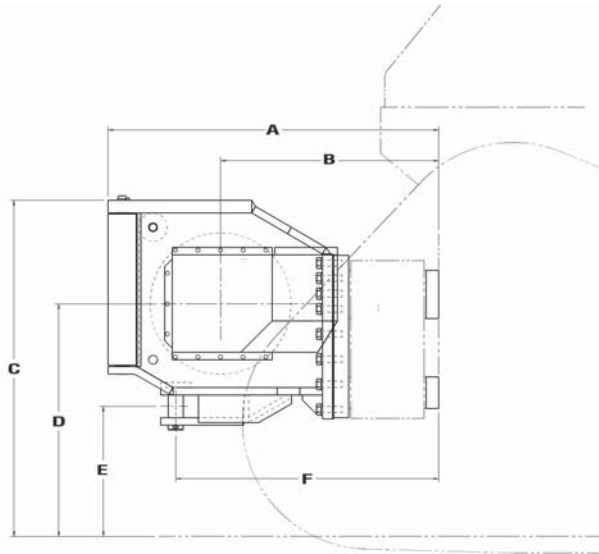

WINCH MODEL	H200			
TRACTOR MODEL	D8T		D9T	
Tractor transmission	Powershift		Powershift	
Winch drive	Hydraulic (High Power)		Hydraulic (High Power)	
<b>A</b> Tractor to rear of winch	1460 mm	<b>57.5"</b>	1645 mm	<b>64.8"</b>
<b>B</b> Tractor to drum centerline	960 mm	<b>37.7"</b>	1075 mm	<b>42.4"</b>
<b>C</b> Ground to top of winch	1760 mm	<b>69.4"</b>	1735 mm	<b>68.3"</b>
<b>D</b> Ground to drum centerline	1240 mm	<b>48.8"</b>	1215 mm	<b>47.9"</b>
<b>E</b> Ground to center of hitch	725 mm	<b>28.5"</b>	700 mm	<b>27.5"</b>
<b>F</b> Tractor to drawbar pin centerline	1170 mm	<b>46.1"</b>	1305 mm	<b>51.3"</b>
Winch width (not shown) <sup>1</sup>	1400 mm	<b>55"</b>	1400 mm	<b>55"</b>
Drum diameter (not shown)	380 mm	<b>15"</b>	380 mm	<b>15"</b>
Weight <sup>2</sup>	3180 kg	<b>7015 lb</b>	3180 kg <sup>5</sup>	<b>7015 lb<sup>5</sup></b>
Oil refill capacity	16.5 L	<b>4.4 U.S. gal</b>	16.5 L	<b>4.4 U.S. gal</b>
Wire rope diameter:				
Recommended	35 mm	<b>1.38"</b>	35 mm	<b>1.38"</b>
Optional	38 mm	<b>1.5"</b>	38 mm	<b>1.5"</b>
Maximum theoretical drum capacity: <sup>3</sup>				
Recommended rope	81 m	<b>266'</b>	81 m	<b>266'</b>
Optional rope	68 m	<b>224'</b>	68 m	<b>224'</b>
Maximum recommended drum capacity: <sup>4</sup>				
Recommended rope	64 m	<b>211'</b>	64 m	<b>211'</b>
Optional rope	42 m	<b>138'</b>	42 m	<b>138'</b>
Wire rope ferrule size (OD)	71 mm	<b>2.81"</b>	71 mm	<b>2.81"</b>
Wire rope ferrule size (length)	79 mm	<b>3.12"</b>	79 mm	<b>3.12"</b>

<sup>1</sup>Width does not include mounting brackets/adapters (if any).

<sup>2</sup>Weight shown is base winch only. Does not include mounting arrangement, control arrangement, oil, or wire rope.

<sup>3</sup>Per SAE J1158.

<sup>4</sup>Per SAE J706 (K=9).

<sup>5</sup>5080 kg (**11,200 lb**) with counterweight.

WINCH MODEL	PA40	PA50	H60	H85	
<b>TRACTOR MODEL</b>	<b>D3K2, D4K2, D5K2<sup>(5)</sup></b>	<b>D6K2</b>	<b>D5R, D6N</b>	<b>D6T<sup>(6)</sup></b>	
Tractor transmission . . . . .	Hydrostatic	Hydrostatic	Powershift	Powershift	
Winch drive . . . . .	Hydrostatic	Hydrostatic	Hydraulic (Ripper)	Hydraulic (Ripper)	
<b>British Units of Measure</b>					
Bare Drum	Maximum line pull <sup>(1)</sup> . . . . . lb	40,000	50,000	60,000	85,000
	Rated line speed <sup>(2)</sup> . . . . . fpm	49	45	33	31
	Maximum line speed <sup>(3)</sup> . . . . . fpm	132	124	99	64
Full Drum <sup>(4)</sup>	Maximum line pull <sup>(1)</sup> . . . . . lb	25,000	26,000	35,000	52,800
	Rated line speed <sup>(2)</sup> . . . . . fpm	78	83	56	50
	Maximum line speed <sup>(3)</sup> . . . . . fpm	207	230	170	93
<b>Metric Units of Measure</b>					
Bare Drum	Maximum line pull <sup>(1)</sup> . . . . . kN	177.9	222.4	266.9	378.5
	Rated line speed <sup>(2)</sup> . . . . . m/min	15	14	10	9
	Maximum line speed <sup>(3)</sup> . . . . . m/min	40	38	30	20
Full Drum <sup>(4)</sup>	Maximum line pull <sup>(1)</sup> . . . . . kN	111.2	115.7	155.7	259.9
	Rated line speed <sup>(2)</sup> . . . . . m/min	24	25	17	15
	Maximum line speed <sup>(3)</sup> . . . . . m/min	63	70	52	28

<sup>(1)</sup>“Maximum line pull” is lesser of winch catalog rating or calculated maximum line pull at maximum tractor hydraulic system pressure.

<sup>(2)</sup>“Rated line speed” is calculated maximum line speed at maximum line pull.

<sup>(3)</sup>“Maximum line speed” is calculated maximum no-load line speed at maximum tractor hydraulic system flow.

<sup>(4)</sup>“Full Drum” as defined by SAE J1158.

<sup>(5)</sup>Meets Tier 3/Stage IIIA/Japan 2006 (Tier 3) equivalent emission standards.

<sup>(6)</sup>Meets Tier 4 Final/Stage IV/Japan 2014 (Tier 4 Final) emission standards.

WINCH MODEL	H110B	PA90			
<b>TRACTOR MODEL</b>	<b>D6T<sup>(5)</sup></b>	<b>D6R</b>	<b>D6T</b>	<b>D7E</b>	
Tractor transmission . . . . .	Powershift	Powershift	Powershift	Electric	
Winch drive . . . . .	Hydraulic (Ripper)	Hydraulic (High Power)	Hydraulic (High Power)	Hydraulic (High Power)	
<b>British Units of Measure</b>					
Bare Drum	Maximum line pull <sup>(1)</sup> . . . . . lb	110,000	90,000	90,000	90,000
	Rated line speed <sup>(2)</sup> . . . . . fpm	20	54	35	32
	Maximum line speed <sup>(3)</sup> . . . . . fpm	38	87	68	71
Full Drum <sup>(4)</sup>	Maximum line pull <sup>(1)</sup> . . . . . lb	66,200	53,600	53,600	53,600
	Rated line speed <sup>(2)</sup> . . . . . fpm	33	85	59	53
	Maximum line speed <sup>(3)</sup> . . . . . fpm	63	139	114	120
<b>Metric Units of Measure</b>					
Bare Drum	Maximum line pull <sup>(1)</sup> . . . . . kN	490.3	400.3	400.3	400.3
	Rated line speed <sup>(2)</sup> . . . . . m/min	6	16	10	10
	Maximum line speed <sup>(3)</sup> . . . . . m/min	12	26	20	22
Full Drum <sup>(4)</sup>	Maximum line pull <sup>(1)</sup> . . . . . kN	295.2	238.4	238.4	238.4
	Rated line speed <sup>(2)</sup> . . . . . m/min	10	26	18	16
	Maximum line speed <sup>(3)</sup> . . . . . m/min	19	42	34	37

<sup>(1)</sup>“Maximum line pull” is lesser of winch catalog rating or calculated maximum line pull at maximum tractor hydraulic system pressure.

<sup>(2)</sup>“Rated line speed” is calculated maximum line speed at maximum line pull.

<sup>(3)</sup>“Maximum line speed” is calculated maximum no-load line speed at maximum tractor hydraulic system flow.

<sup>(4)</sup>“Full Drum” as defined by SAE J1158.

<sup>(5)</sup>Meets Tier 4 Interim/Stage IIIB/Japan 2011 (Tier 4 Interim) equivalent emission standards.

WINCH MODEL		H110B	H110B	PA110B
TRACTOR MODEL		D7E	D7R	D7R
Tractor transmission. . . . .		Electric	Powershift	Powershift
Winch drive . . . . .		Hydraulic (Ripper)	Hydraulic (Ripper)	Hydraulic (High Power)
<b>British Units of Measure</b>				
Bare Drum	Maximum line pull <sup>(1)</sup> . . . . . lb	110,000	101,000	110,000
	Rated line speed <sup>(2)</sup> . . . . . fpm	23	24	33
	Maximum line speed <sup>(3)</sup> . . . . . fpm	55	51	100
Full Drum <sup>(4)</sup>	Maximum line pull <sup>(1)</sup> . . . . . lb	66,200	61,000	66,500
	Rated line speed <sup>(2)</sup> . . . . . fpm	38	39	54
	Maximum line speed <sup>(3)</sup> . . . . . fpm	90	84	165
<b>Metric Units of Measure</b>				
Bare Drum	Maximum line pull <sup>(1)</sup> . . . . . kN	490.3	449.3	489.3
	Rated line speed <sup>(2)</sup> . . . . . m/min	7	7	10
	Maximum line speed <sup>(3)</sup> . . . . . m/min	17	15	30
Full Drum <sup>(4)</sup>	Maximum line pull <sup>(1)</sup> . . . . . kN	295.2	271.3	295.8
	Rated line speed <sup>(2)</sup> . . . . . m/min	12	12	16
	Maximum line speed <sup>(3)</sup> . . . . . m/min	27	25	50

<sup>(1)</sup>“Maximum line pull” is lesser of winch catalog rating or calculated maximum line pull at maximum tractor hydraulic system pressure.

<sup>(2)</sup>“Rated line speed” is calculated maximum line speed at maximum line pull.

<sup>(3)</sup>“Maximum line speed” is calculated maximum no-load line speed at maximum tractor hydraulic system flow.

<sup>(4)</sup>“Full Drum” as defined by SAE J1158.

WINCH MODEL		H140		PA140	
TRACTOR MODEL		D8R, D8T	D9R, D9T	D8T	D9T
Tractor transmission. . . . .		Powershift	Powershift	Powershift	Powershift
Winch drive . . . . .		Hydraulic (Ripper)	Hydraulic (Ripper)	Hydraulic (High Power)	Hydraulic (High Power)
<b>British Units of Measure</b>					
Bare Drum	Maximum line pull <sup>(1)</sup> . . . . . lb	140,000	140,000	140,000	140,000
	Rated line speed <sup>(2)</sup> . . . . . fpm	19	17	23	23
	Maximum line speed <sup>(3)</sup> . . . . . fpm	38	35	46	46
Full Drum <sup>(4)</sup>	Maximum line pull <sup>(1)</sup> . . . . . lb	84,600	84,600	84,600	84,600
	Rated line speed <sup>(2)</sup> . . . . . fpm	31	28	38	38
	Maximum line speed <sup>(3)</sup> . . . . . fpm	63	58	76	76
<b>Metric Units of Measure</b>					
Bare Drum	Maximum line pull <sup>(1)</sup> . . . . . kN	622.8	622.8	622.8	622.8
	Rated line speed <sup>(2)</sup> . . . . . m/min	6	5	7	7
	Maximum line speed <sup>(3)</sup> . . . . . m/min	11	10	14	14
Full Drum <sup>(4)</sup>	Maximum line pull <sup>(1)</sup> . . . . . kN	376.3	376.3	376.3	376.3
	Rated line speed <sup>(2)</sup> . . . . . m/min	9	8	11	11
	Maximum line speed <sup>(3)</sup> . . . . . m/min	19	17	23	23

<sup>(1)</sup>“Maximum line pull” is lesser of winch catalog rating or calculated maximum line pull at maximum tractor hydraulic system pressure.

<sup>(2)</sup>“Rated line speed” is calculated maximum line speed at maximum line pull.

<sup>(3)</sup>“Maximum line speed” is calculated maximum no-load line speed at maximum tractor hydraulic system flow.

<sup>(4)</sup>“Full Drum” as defined by SAE J1158.

WINCH MODEL		PA55	PA56
TRACTOR MODEL		D5R, D6N	D6R, D6T, D6T <sup>(6)</sup>
Tractor transmission . . . . .		Powershift	Powershift
Winch drive . . . . .		PTO	PTO
<b>British Units of Measure</b>			
Bare Drum	Rated line pull <sup>(1)</sup> . . . . . lb	36,600	59,100
	Maximum line pull <sup>(2)</sup> . . . . . lb	69,200	89,800
	Rated line speed <sup>(3)</sup> . . . . . fpm	92	80
	Maximum line speed <sup>(4)</sup> . . . . . fpm	141	130
Full Drum <sup>(5)</sup>	Rated line pull <sup>(1)</sup> . . . . . lb	20,900	34,400
	Maximum line pull <sup>(2)</sup> . . . . . lb	54,100	76,300
	Rated line speed <sup>(3)</sup> . . . . . fpm	158	136
	Maximum line speed <sup>(4)</sup> . . . . . fpm	218	224
<b>Slow speed gearing</b>			
Bare Drum	Rated line pull <sup>(1)</sup> . . . . . lb	50,000	70,000
	Maximum line pull <sup>(2)</sup> . . . . . lb	69,200	89,800
	Rated line speed <sup>(3)</sup> . . . . . fpm	38	35
	Maximum line speed <sup>(4)</sup> . . . . . fpm	53	58
Full Drum <sup>(5)</sup>	Rated line pull <sup>(1)</sup> . . . . . lb	50,000	70,000
	Maximum line pull <sup>(2)</sup> . . . . . lb	69,200	89,800
	Rated line speed <sup>(3)</sup> . . . . . fpm	66	63
	Maximum line speed <sup>(4)</sup> . . . . . fpm	91	103
<b>Metric Units of Measure</b>			
Bare Drum	Rated line pull <sup>(1)</sup> . . . . . kN	162.8	262.9
	Maximum line pull <sup>(2)</sup> . . . . . kN	307.8	399.5
	Rated line speed <sup>(3)</sup> . . . . . m/min	28	24
	Maximum line speed <sup>(4)</sup> . . . . . m/min	43	40
Full Drum <sup>(5)</sup>	Rated line pull <sup>(1)</sup> . . . . . kN	93.0	153.0
	Maximum line pull <sup>(2)</sup> . . . . . kN	240.6	153.9
	Rated line speed <sup>(3)</sup> . . . . . m/min	48	41
	Maximum line speed <sup>(4)</sup> . . . . . m/min	66	68
<b>Slow speed gearing</b>			
Bare Drum	Rated line pull <sup>(1)</sup> . . . . . kN	222.4	311.4
	Maximum line pull <sup>(2)</sup> . . . . . kN	307.8	399.5
	Rated line speed <sup>(3)</sup> . . . . . m/min	12	11
	Maximum line speed <sup>(4)</sup> . . . . . m/min	16	18
Full Drum <sup>(5)</sup>	Rated line pull <sup>(1)</sup> . . . . . kN	222.4	311.4
	Maximum line pull <sup>(2)</sup> . . . . . kN	307.8	399.5
	Rated line speed <sup>(3)</sup> . . . . . m/min	20	19
	Maximum line speed <sup>(4)</sup> . . . . . m/min	28	31

<sup>(1)</sup>“Rated line pull” is lesser of winch catalog rating or calculated line pull at maximum tractor PTO output power.  
<sup>(2)</sup>“Maximum line pull” is lesser of calculated line pull at maximum tractor PTO output torque or catalog breaking strength of maximum optional size new IWRC IPS wire rope.  
<sup>(3)</sup>“Rated line speed” is calculated line speed at maximum tractor PTO output power.  
<sup>(4)</sup>“Maximum line speed” is calculated no-load line speed at maximum tractor engine PTO output speed.  
<sup>(5)</sup>“Full Drum” as defined by SAE J1158.  
<sup>(6)</sup>Meets Tier 4 Final/Stage IV/Japan 2014 (Tier 4 Final) emission standards.



<b>WINCH MODEL</b>		<b>H200</b>	
<b>TRACTOR MODEL</b>		<b>D8T</b>	<b>D9T</b>
Tractor transmission . . . . .		<b>Powershift</b>	<b>Powershift</b>
Winch drive . . . . .		<b>Hydraulic (High Power)</b>	<b>Hydraulic (High Power)</b>
<b>British Units of Measure</b>			
Bare Drum	Maximum line pull <sup>(1)</sup> . . . . . lb	180,000	200,000
	Rated line speed <sup>(2)</sup> . . . . . fpm	17	17
	Maximum line speed <sup>(3)</sup> . . . . . fpm	38	38
Full Drum <sup>(4)</sup>	Maximum line pull <sup>(1)</sup> . . . . . lb	112,000	124,500
	Rated line speed <sup>(2)</sup> . . . . . fpm	27	27
	Maximum line speed <sup>(3)</sup> . . . . . fpm	61	61
<b>Metric Units of Measure</b>			
Bare Drum	Maximum line pull <sup>(1)</sup> . . . . . kN	800.7	889.6
	Rated line speed <sup>(2)</sup> . . . . . m/min	5	5
	Maximum line speed <sup>(3)</sup> . . . . . m/min	11	11
Full Drum <sup>(4)</sup>	Maximum line pull <sup>(1)</sup> . . . . . kN	498.2	553.8
	Rated line speed <sup>(2)</sup> . . . . . m/min	8	8
	Maximum line speed <sup>(3)</sup> . . . . . m/min	18	18

<sup>(1)</sup>“Maximum line pull” is lesser of winch catalog rating or calculated maximum line pull at maximum hydraulic system pressure.

<sup>(2)</sup>“Rated line speed” is calculated maximum line speed at maximum hydraulic system pressure and flow with winch motor at maximum displacement.

<sup>(3)</sup>“Maximum line speed” is calculated maximum no-load line speed at maximum hydraulic system flow with winch motor at minimum displacement.

<sup>(4)</sup>“Full Drum” as defined by SAE J1158.

**Allied Features:**

- **Proven performance on Caterpillar.** Allied winches trace their roots to Hyster winches on Cat tractors since 1929. Allied acquired Hyster winches in 1990, maintaining the same engineering excellence. Existing dealer parts inventory continues to be interchangeable to support the thousands of Allied/Hyster winches in the field.
- **“Plug and Play” design.** Winches come complete with all the necessary parts for simple and easy field installation on any tractor. They do not require Winch Ready packages pre-ordered on the tractors. This simplifies dealer inventory planning.
- **Self-Contained Hydraulics (SCH) design.** All hoses, pump and valve are inside the PTO winch frame, totally eliminating external leakage.

**Standard Equipment**

- Freespool function for W3C, H4A, W5C, H5C, W6F, W6G and H6H winches. Adjustable freespool drag to allow cable to be pulled out easily by hand.
- Heavy duty box-section winch frame withstands demanding side pulls without the need for fairlead.
- Brake off function for most winches. Keeps cable tight while the tractor drives away to prevent cable bird nesting.
- Multiple-disc oil clutches and brake on PTO winches are oil-cooled for long life.
- Drawbar for most winches. Provides an additional hitch for load towing.
- Power line-in and power line-out.

**Optional Equipment**

- Fairlead to handle frequent side pulls from all angles. Hardened vertical and horizontal rollers reduce cable wear.
- Arch works like a raised fairlead to lift loads off ground for efficient skidding.
- Choice of standard gear ratio for fast operation in logging, or slow speed gear ratio for fine speed control in pipelaying and power line sagging applications.
- Electronic control for precise speed control.

**Two families of winches – Power Take-Off (PTO) driven or Hydraulically driven winches covering D3 through D10 tractors, pipelayers and track loaders, the most comprehensive winch in the industry.**

- **PTO** winches able to utilize full range of engine power. Brute force and fast line speeds.
- **Hydraulic** winches provide fingertip precision control over line speed. Motor only turns on demand equaling less wear and maintenance.

**Winch Selection Guide:**

Tractor Class*	PTO Winch	Hydraulic Winch
D3-5K	—	H4A
D6K	—	H5C
527 TSK	W6F	—
D6N, D5R	W5C, W6G, W6F	H5C, H6H
D6T, D6R	W6G, W6F	H6H
D7R	W8L	H8L
D7E	—	H8L
D8-9-10R, D8-9-10T	W12E	H12E

\*For non-current tractors contact Allied Systems Company for winch options.

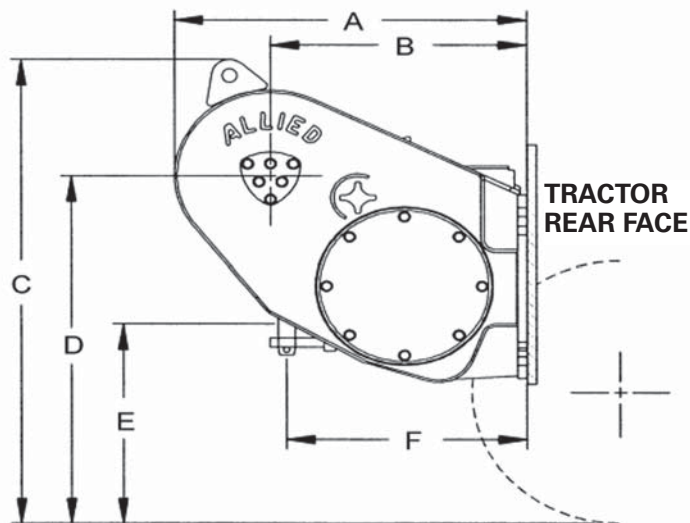

WINCH MODEL	H4AT		H4AH Hi-P	
TRACTOR MODEL	D3K2, D4K2, D5K2*		D3K2, D4K2, D5K2*	
Winch drive	Ripper Hydraulics		Allied Hi-Flow Pump	
Winch type	Standard		Hi-Performance	
A Tractor to rear of winch	813 mm	32"	813 mm	32"
B Tractor to drum centerline	610 mm	24"	610 mm	24"
C Ground to top of winch	1143 mm	45"	1143 mm	45"
D Ground to drum centerline	889 mm	35"	889 mm	35"
E Ground to center of hitch	508 mm	20"	508 mm	20"
F Tractor to pin centerline	584 mm	23"	584 mm	23"
Overall width (not shown)	737 mm	29"	737 mm	29"
Drum diameter (not shown)	203 mm	8"	203 mm	8"
Weight	771 kg	1700 lb	812 kg	1790 lb
Oil refill capacity	19 L	5 U.S. gal	19 L	5 U.S. gal
Wire rope diameter:				
Recommended	16 mm	0.63"	16 mm	0.63"
Optional	19 mm	0.75"	19 mm	0.75"
Drum capacity:				
Recommended rope	84 m	277'	84 m	277'
Optional rope	59 m	195'	59 m	195'
Wire rope ferrule size (OD)	38 mm	1.5"	38 mm	1.5"
Wire rope ferrule size (length)	51 mm	2"	51 mm	2"

\*Specifications based on representative models marked \*. Others similar.

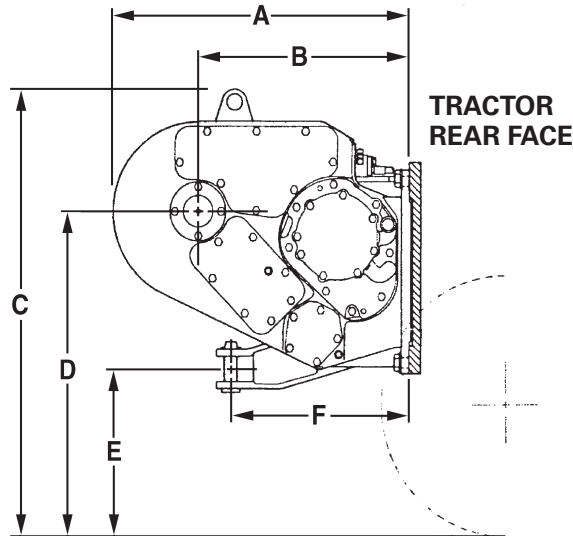

WINCH MODEL	H5CT		H5CH Hi-P	
TRACTOR MODEL	D6K2		D6K2	
Winch drive	Ripper Hydraulics		Allied Hi-Flow Pump	
Winch type	Standard		Hi-Performance	
A Tractor to rear of winch	864 mm	34"	864 mm	34"
B Tractor to drum centerline	635 mm	25"	635 mm	25"
C Ground to top of winch	1118 mm	44"	1118 mm	44"
D Ground to drum centerline	787 mm	31"	787 mm	31"
E Ground to center of hitch	381 mm	15"	381 mm	15"
F Tractor to pin centerline	559 mm	22"	559 mm	22"
Overall width (not shown)	813 mm	32"	813 mm	32"
Drum diameter (not shown)	229 mm	9"	229 mm	9"
Weight	898 kg	1980 lb	930 kg	2050 lb
Oil refill capacity	12.5 L	3.3 U.S. gal	12.5 L	3.3 U.S. gal
Wire rope diameter:				
Recommended	19 mm	0.75"	19 mm	0.75"
Optional	22 mm	0.88"	22 mm	0.88"
Drum capacity:				
Recommended rope	91 m	298'	91 m	298'
Optional rope	66 m	215'	66 m	215'
Wire rope ferrule size (OD)	51 mm	2"	51 mm	2"
Wire rope ferrule size (length)	57 mm	2.25"	57 mm	2.25"

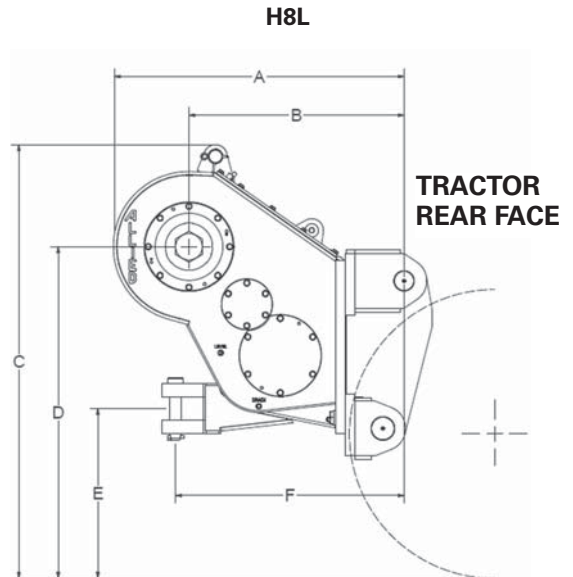
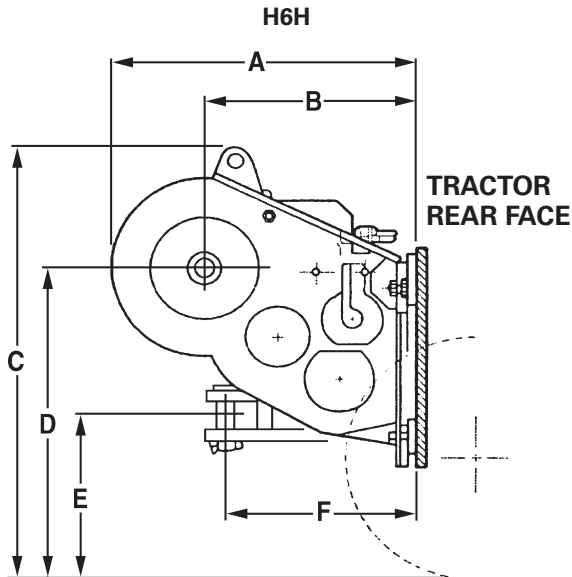

WINCH MODEL	H6H		H8L	
TRACTOR MODEL	D6N, D6R, D6R XL, D6T*		D7E*, D7R	
Winch drive	Ripper Hydraulics		Hydraulic	
Winch type	Standard		Standard	
A Tractor to rear of winch	1219 mm	48"	1143 mm	45"
B Tractor to drum centerline	940 mm	37"	813 mm	32"
C Ground to top of winch	1549 mm	61"	1651 mm	65"
D Ground to drum centerline	1194 mm	47"	1270 mm	50"
E Ground to center of hitch	711 mm	28"	660 mm	26"
F Tractor to pin centerline	940 mm	37"	864 mm	34"
Overall width (not shown)	1041 mm	41"	1067 mm	42"
Drum diameter (not shown)	254 mm	10"	305 mm	12"
Weight	1284 kg	2830 lb	1542 kg	3400 lb
Oil refill capacity	8 L	2.1 U.S. gal	15 L	4 U.S. gal
Wire rope diameter:				
Recommended	22 mm	0.88"	25 mm	1"
Optional	25 mm	1"	29 mm	1.12"
Drum capacity:				
Recommended rope	91 m	297'	102 m	334'
Optional rope	70 m	230'	81 m	267'
Wire rope ferrule size (OD)	51 mm	2"	57 mm	2.25"
Wire rope ferrule size (length)	57 mm	2.25"	60 mm	2.38"

\*Specifications based on representative models marked \*. Others similar.

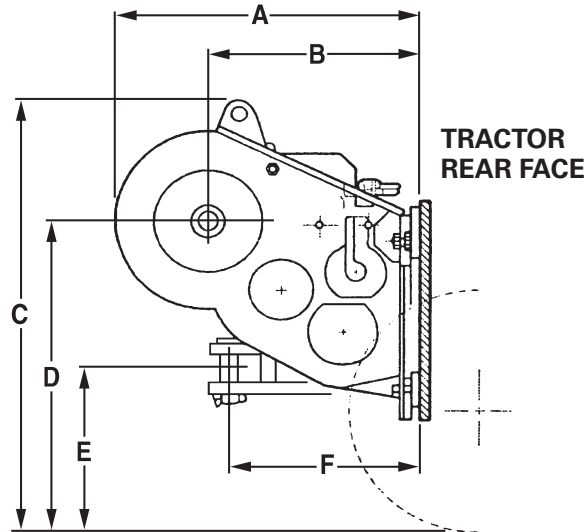

WINCH MODEL	H12E		
TRACTOR MODEL	D8T*, D9T, D10T2		
Winch drive		Hydraulic	
Winch type		Standard	
A Tractor to rear of winch	1499 mm		59"
B Tractor to drum centerline	1168 mm		46"
C Ground to top of winch	1778 mm		70"
D Ground to drum centerline	1372 mm		54"
E Ground to center of hitch	711 mm		28"
F Tractor to pin centerline	1295 mm		51"
Overall width (not shown)	1245 mm		49"
Drum diameter (not shown)	356 mm		14"
Weight	2087 kg		4600 lb
Oil refill capacity	26.5 L		7 U.S. gal
Wire rope diameter:			
Recommended	29 mm		1.13"
Optional	32 mm		1.25"
Drum capacity:			
Recommended rope	70 m		229'
Optional rope	55 m		182'
Wire rope ferrule size (OD)	57 mm		2.25"
Wire rope ferrule size (length)	60 mm		2.38"

\*Specifications based on representative models marked \*. Others similar.

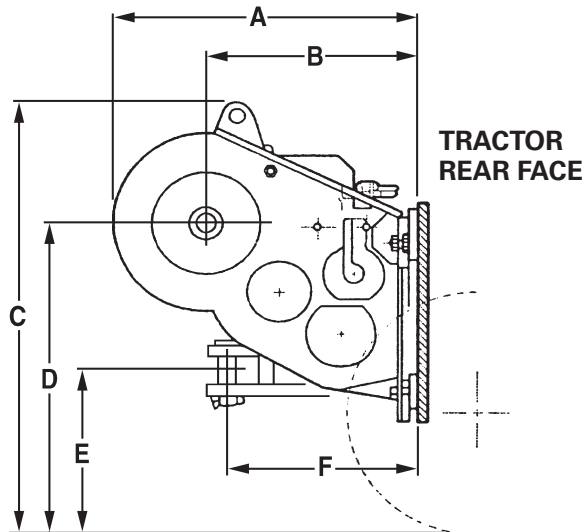

WINCH MODEL	W6G*		W6F*			
	D5R2		527		D6R2	
TRACTOR MODEL	PTO		PTO		PTO	
	Standard		Standard		Standard	
A Tractor to rear of winch	1041 mm	3'5"	1041 mm	3'5"	1244 mm	4'1"
B Tractor to drum centerline	737 mm	2'5"	762 mm	2'6"	965 mm	3'2"
C Ground to top of winch	1549 mm	5'1"	1549 mm	5'1"	1549 mm	5'1"
D Ground to drum centerline	1193 mm	3'11"	1193 mm	3'11"	1193 mm	3'11"
E Ground to center of hitch	711 mm	2'4"	711 mm	2'4"	711 mm	2'4"
F Tractor to pin centerline	737 mm	2'5"	737 mm	2'5"	737 mm	2'5"
Overall width (not shown)	1000 mm	3'4"	965 mm	3'2"	965 mm	3'2"
Drum diameter (not shown)	254 mm	10"	254 mm	10"	254 mm	10"
Weight	1360 kg	3000 lb	1360 kg	3000 lb	1360 kg	3000 lb
Oil refill capacity	62.5 L	16.5 U.S. gal	72 L	19 U.S. gal	72 L	19 U.S. gal
Wire rope diameter:						
Recommended	22 mm	0.88"	22 mm	0.88"	22 mm	0.88"
Optional	25 mm	1"	25 mm	1"	25 mm	1"
Drum capacity:						
Recommended rope	82.6 m	271'	87 m	287'	87 m	287'
Optional rope	64 m	210'	68 m	223'	68 m	223'
Wire rope ferrule size (OD)	51 mm	2"	51 mm	2"	51 mm	2"
Wire rope ferrule size (length)	57 mm	2.25"	57 mm	2.25"	57 mm	2.25"

\*W6F winch is configured for forestry applications, W6G for all other applications.

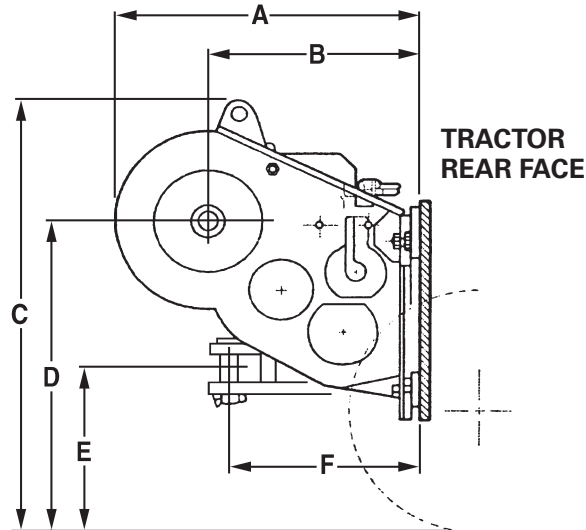

WINCH MODEL	W6G				W8L	
	D6R, D6RXL, D6T*		D6N		D7R	
Tractor Model	D6R, D6RXL, D6T*		D6N		D7R	
Winch drive	PTO		PTO		PTO	
Winch type	Standard		Standard		Standard	
A Tractor to rear of winch	1245 mm	49"	1245 mm	49"	1245 mm	49"
B Tractor to drum centerline	965 mm	38"	965 mm	38"	965 mm	38"
C Ground to top of winch	1549 mm	61"	1549 mm	61"	1600 mm	63"
D Ground to drum centerline	1194 mm	47"	1194 mm	47"	1219 mm	48"
E Ground to center of hitch	711 mm	28"	711 mm	28"	610 mm	24"
F Tractor to pin centerline	940 mm	37"	940 mm	37"	1067 mm	42"
Overall width (not shown)	965 mm	38"	965 mm	38"	1041 mm	41"
Drum diameter (not shown)	254 mm	10"	254 mm	10"	305 mm	12"
Weight	1542 kg	3400 lb	1542 kg	3400 lb	1724 kg	3800 lb
Oil refill capacity	72 L	19 U.S. gal	72 L	19 U.S. gal	72 L	19 U.S. gal
Wire rope diameter:						
Recommended	22 mm	0.88"	22 mm	0.88"	25 mm	1"
Optional	25 mm	1"	25 mm	1"	29 mm	1.13"
Drum capacity:						
Recommended rope	87 m	287'	87 m	287'	84 m	275'
Optional rope	58 m	189'	58 m	189'	54 m	176'
Wire rope ferrule size (OD)	51 mm	2"	51 mm	2"	57 mm	2.25"
Wire rope ferrule size (length)	57 mm	2.25"	57 mm	2.25"	60 mm	2.38"

\*Specifications based on representative models marked \*. Others similar.



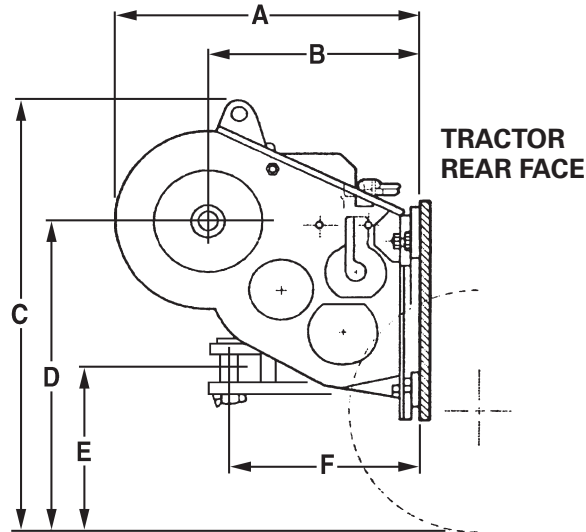

WINCH MODEL	W12E			
	D8T*, D9R, D9T, PL83, PL87		D10T2	
Tractor Model	PTO		PTO	
Winch drive	Standard		Standard	
Winch type	Standard		Standard	
A Tractor to rear of winch	1473 mm	58"	1346 mm	53"
B Tractor to drum centerline	1143 mm	45"	1041 mm	41"
C Ground to top of winch	1753 mm	69"	1753 mm	69"
D Ground to drum centerline	1346 mm	53"	1346 mm	53"
E Ground to center of hitch	686 mm	27"	686 mm	27"
F Tractor to pin centerline	1270 mm	50"	1168 mm	46"
Overall width (not shown)	1219 mm	48"	1219 mm	48"
Drum diameter (not shown)	356 mm	14"	356 mm	14"
Weight	2880 kg	6350 lb	4105 kg	9050 lb
Oil refill capacity	121 L	32 U.S. gal	121 L	32 U.S. gal
Wire rope diameter:				
Recommended	29 mm	1.125"	29 mm	1.125"
Optional	32 mm	1.25"	32 mm	1.25"
Drum capacity:				
Recommended rope	69 m	228'	69 m	228'
Optional rope	55 m	181'	55 m	181'
Wire rope ferrule size (OD)	57 mm	2.25"	57 mm	2.25"
Wire rope ferrule size (length)	60 mm	2.38"	60 mm	2.38"

\*Specifications based on representative models marked \*. Others similar.

WINCH MODEL		H4AT	H4AH
TRACTOR MODEL		D3K2, D4K2, D5K2*	D3K2, D4K2, D5K2*
Winch drive . . . . .		Ripper Hydraulics	Allied Hi-Flow Pump
Winch type. . . . .		Standard	Hi-Performance
<b>British Units of Measure</b>			
Bare Drum	Maximum line pull** . . . . . lb	32,150	38,600
	Line speed at . . . . . fpm	34	94
	Typical line pull of . . . . . lb	20,000	20,000
	Maximum line speed . . . . . fpm	46	100
Full Drum	Maximum line pull** . . . . . lb	18,350	22,050
	Line speed at . . . . . fpm	48	98
	Typical line pull of . . . . . lb	17,400	20,000
	Maximum line speed . . . . . fpm	81	176
<b>Metric Units of Measure</b>			
Bare Drum	Maximum line pull** . . . . . kg	14 583	17 509
	Line speed at . . . . . m/min	10.4	28.7
	Typical line pull of . . . . . kg	9072	9072
	Maximum line speed . . . . . m/min	14	31.5
Full Drum	Maximum line pull** . . . . . kg	8323	10 002
	Line speed at . . . . . m/min	14.6	29.9
	Typical line pull of . . . . . kg	7893	9072
	Maximum line speed . . . . . m/min	25	54

Performance based on standard gear ratio. Optional gear ratios available for different line speed and line pull requirements.

\*Specifications based on representative models marked \*. Others similar.

\*\*Based on lower measurement of maximum line pull that the tractor can develop with the standard gear ratio, or the breaking strength of the maximum recommended wire.

<b>WINCH MODEL</b>		<b>H5CT</b>	<b>H5CH</b>
<b>TRACTOR MODEL</b>		<b>D6K2</b>	<b>D6K2</b>
Winch drive . . . . .		<b>Ripper Hydraulics</b>	<b>Allied Hi-Flow Pump</b>
Winch type. . . . .		<b>Standard</b>	<b>Hi-Performance</b>
<b>British Units of Measure</b>			
Bare Drum	Maximum line pull* . . . . . lb	66,700	59,750
	Line speed at . . . . . fpm	25	97
	Typical line pull of . . . . . lb	30,000	30,000
	Maximum line speed . . . . . fpm	52	128
Full Drum	Maximum line pull* . . . . . lb	35,950	32,200
	Line speed at . . . . . fpm	47	70
	Typical line pull of . . . . . lb	30,000	30,000
	Maximum line speed . . . . . fpm	97	237
<b>Metric Units of Measure</b>			
Bare Drum	Maximum line pull* . . . . . kg	30 255	27 102
	Line speed at . . . . . m/min	7.6	29.6
	Typical line pull of . . . . . kg	13 608	13 608
	Maximum line speed . . . . . m/min	16	39
Full Drum	Maximum line pull* . . . . . kg	16 307	14 606
	Line speed at . . . . . m/min	14.3	21.3
	Typical line pull of . . . . . kg	13 608	13 608
	Maximum line speed . . . . . m/min	30	72

Performance based on standard gear ratio. Optional gear ratios available for different line speed and line pull requirements.

\*Based on lower measurement of maximum line pull that the tractor can develop with the standard gear ratio, or the breaking strength of the maximum recommended wire.

<b>WINCH MODEL</b>		<b>H6H</b>	<b>H8L</b>	<b>H12E</b>
<b>TRACTOR MODEL</b>		<b>D6T*, D6R, D6N</b>	<b>D7E</b>	<b>D8T*, D9T, D10T2</b>
Winch drive . . . . .		<b>Ripper Hydraulics</b>	<b>Hydraulic</b>	<b>Hydraulic</b>
Winch type. . . . .		<b>Standard</b>	<b>Standard</b>	<b>Standard</b>
<b>British Units of Measure</b>				
Bare Drum	Maximum line pull** . . . . . lb	88,800	112,500	130,250
	Line speed at . . . . . fpm	58	29	22
	Typical line pull of . . . . . lb	40,000	50,000	80,000
	Maximum line speed . . . . . fpm	69	65	76
Full Drum	Maximum line pull** . . . . . lb	48,250	72,600	83,650
	Line speed at . . . . . fpm	60	47	35
	Typical line pull of . . . . . lb	40,000	50,000	80,000
	Maximum line speed . . . . . fpm	129	106	119
<b>Metric Units of Measure</b>				
Bare Drum	Maximum line pull** . . . . . kg	40 280	52 029	59 080
	Line speed at . . . . . m/min	18.0	8.8	7.0
	Typical line pull of . . . . . kg	18 144	22 700	36 287
	Maximum line speed . . . . . m/min	21.0	19.8	23.2
Full Drum	Maximum line pull** . . . . . kg	21 886	32 900	37 943
	Line speed at . . . . . m/min	18.0	14.3	10.7
	Typical line pull of . . . . . kg	18 144	22 700	36 287
	Maximum line speed . . . . . m/min	39.0	32.3	36.3

Performance based on standard gear ratio. Optional gear ratios available for different line speed and line pull requirements.

\*Specifications based on representative models marked \*. Others similar.

\*\*Based on lower measurement of maximum line pull that the tractor can develop with the standard gear ratio, or the breaking strength of the maximum recommended wire.

<b>WINCH MODEL</b>		<b>W6F</b>	<b>W6G</b>	
<b>TRACTOR MODEL</b>		<b>527</b>	<b>D5R2</b>	<b>D6T*, D6R2</b>
Winch drive.....		<b>PTO</b>	<b>PTO</b>	<b>PTO</b>
Winch type.....		<b>Standard</b>	<b>Standard</b>	<b>Standard</b>
<b>British Units of Measure</b>				
Bare Drum	Maximum line pull** ..... lb	88,800	88,800	88,800
	Line speed at ..... fpm	93	59	93
	Typical line pull of ..... lb	40,000	40,000	40,000
	Maximum line speed ..... fpm	120	68	120
Full Drum	Maximum line pull** ..... lb	71,200	88,800	71,200
	Line speed at ..... fpm	99	90	99
	Typical line pull of ..... lb	40,000	40,000	40,000
	Maximum line speed ..... fpm	219	124	219
<b>Metric Units of Measure</b>				
Bare Drum	Maximum line pull** ..... kg	40 280	40 280	40 280
	Line speed at ..... m/min	28.3	18.0	28.3
	Typical line pull of ..... kg	18 144	18 144	18 144
	Maximum line speed ..... m/min	37	21	37
Full Drum	Maximum line pull** ..... kg	32 296	40 280	32 296
	Line speed at ..... m/min	30.2	27.4	30.2
	Typical line pull of ..... kg	18 144	18 144	18 144
	Maximum line speed ..... m/min	67	38	67

Performance based on standard gear ratio. Optional gear ratios available for different line speed and line pull requirements.

\*Specifications based on representative models marked \*. Others similar.

\*\*Based on lower measurement of maximum line pull that the tractor can develop with the standard gear ratio, or the breaking strength of the maximum recommended wire.

WINCH MODEL		W8L	W12E		
TRACTOR MODEL		D7R*, 572R	D8T*, PL83, PL87	D9T	D10T
Winch drive . . . . .		PTO	PTO	PTO	PTO
Winch type. . . . .		Standard	Standard	Standard	Standard
<b>British Units of Measure</b>					
Bare Drum	Maximum line pull** . . . . . lb	112,500	138,800	138,800	138,800
	Line speed at . . . . . fpm	122	52	55	53
	Typical line pull of . . . . . lb	50,000	80,000	80,000	80,000
	Maximum line speed . . . . . fpm	168	59	60	58
Full Drum	Maximum line pull** . . . . . lb	81,700	138,800	138,800	138,800
	Line speed at . . . . . fpm	115	78	82	81
	Typical line pull of . . . . . lb	50,000	80,000	80,000	80,000
	Maximum line speed . . . . . fpm	275	92	93	91
<b>Metric Units of Measure</b>					
Bare Drum	Maximum line pull** . . . . . kg	51 030	62 960	62 960	62 960
	Line speed at . . . . . m/min	37.2	15.8	16.8	16.2
	Typical line pull of . . . . . kg	22 700	36 287	36 287	36 287
	Maximum line speed . . . . . m/min	51.2	18.0	18.3	17.7
Full Drum	Maximum line pull** . . . . . kg	37 058	62 959	62 959	62 959
	Line speed at . . . . . m/min	35.1	23.8	25.0	24.7
	Typical line pull of . . . . . kg	22 700	36 287	36 287	36 287
	Maximum line speed . . . . . m/min	83.8	28.0	28.3	27.7

Performance based on standard gear ratio. Optional gear ratios available for different line speed and line pull requirements.

\*Specifications based on representative models marked \*. Others similar.

\*\*Based on lower measurement of maximum line pull that the tractor can develop with the standard gear ratio, or the breaking strength of the maximum recommended wire.



# UNDERGROUND MINING EQUIPMENT

## Hard Rock Longwall Room & Pillar

### CONTENTS

#### HARD ROCK

Features.....	20-3
Load-Haul-Dumps (LHDs):	
Specifications .....	20-4
Dimensions and Capacities .....	20-6
Bucket Selection .....	20-7
Turning Dimensions .....	20-8
Curves:	
R1300G Rimpull-Speed-Gradeability.....	20-9
R1600H Rimpull-Speed-Gradeability....	20-10
R1700G Rimpull-Speed-Gradeability....	20-11
R2900G Rimpull-Speed-Gradeability ...	20-12
R3000H Rimpull-Speed-Gradeability ...	20-13
Articulated Trucks:	
Specifications .....	20-14
Dimensions and Capacities .....	20-16
Curves:	
AD30 Rimpull-Speed-Gradeability .....	20-18
AD45B Rimpull-Speed-Gradeability .....	20-19
AD55 Rimpull-Speed-Gradeability.....	20-20
AD60 Rimpull-Speed-Gradeability .....	20-21

#### HARD ROCK (continued)

LHD and Truck Systems .....	20-22
Rock Flow System:	
Introduction .....	20-23
Features .....	20-23
Specifications:	
Rock Feeder RF300.....	20-24
Rock Mover RM900 .....	20-24
Rock Straight System:	
Introduction .....	20-25
Features .....	20-26
Specifications:	
Hard Rock Miner HRM220 .....	20-27
Hard Rock Conveyor HRC30 .....	20-28
Hard Rock Roof Support HRS1220 .....	20-29



**LONGWALL**

Introduction . . . . . 20-32

Roof Supports:

    Features . . . . . 20-32

    Specifications . . . . . 20-33

    Special Applications . . . . . 20-34

AFC Systems:

    Features . . . . . 20-35

    Specifications . . . . . 20-36

    Dimensions . . . . . 20-40

    Conveying Performance . . . . . 20-45

Beam Stage Loaders (BSL):

    Features . . . . . 20-48

    Specifications . . . . . 20-48

CST Drive Systems:

    Features . . . . . 20-51

    Specifications . . . . . 20-52

    Rated Power P/Gearbox Ratio  $i [-]$  . . . . . 20-58

Variable Frequency Drives (VFD):

    Features . . . . . 20-60

    Specifications . . . . . 20-61

    Dimensions . . . . . 20-62

Shearers:

    Features . . . . . 20-63

    Specifications . . . . . 20-64

    Dimensions . . . . . 20-71

    Optional Accessories . . . . . 20-81

Automated Plow Systems:

    Features . . . . . 20-82

    Specifications . . . . . 20-83

    Dimensions . . . . . 20-85

Programmable Mining Controls:

    PMC-R:

        Features . . . . . 20-103

        Specifications . . . . . 20-103

    PMC-D and PMC-V:

        Features . . . . . 20-107

        Specifications . . . . . 20-107

    MCU2:

        Features . . . . . 20-111

        Specifications . . . . . 20-111

Roof Support Carriers:

    Features . . . . . 20-113

    Specifications . . . . . 20-114

    Dimensions . . . . . 20-116

    Tractive Effort vs. Speed — Loaded . . . . . 20-118

    % Grade vs. Speed — Loaded . . . . . 20-119

    Lift Capability . . . . . 20-120

Shield Trailers:

    Features . . . . . 20-121

    Specifications . . . . . 20-122

    Dimensions . . . . . 20-123

    SH150 Load Setting Table . . . . . 20-124

**ROOM & PILLAR**

Introduction . . . . . 20-127

Continuous Miners:

    Features . . . . . 20-128

    Specifications . . . . . 20-129

Face Haulers:

    Features . . . . . 20-132

    Specifications . . . . . 20-133

    Dimensions . . . . . 20-134

Continuous Haulage System:

    Features . . . . . 20-135

    Specifications . . . . . 20-136

    Dimensions . . . . . 20-137

Feeder Breakers:

    Features . . . . . 20-138

    Specifications . . . . . 20-139

Roof Bolter:

    Features . . . . . 20-140

    Specifications . . . . . 20-141

Scoops:

    Features . . . . . 20-142

    Specifications . . . . . 20-143

LHD Vehicles (Load-Haul-Dumps):

    Features . . . . . 20-144

    Specifications . . . . . 20-145

    Tractive Effort vs. Speed — Loaded . . . . . 20-147

    % Grade vs. Speed — Loaded . . . . . 20-149

    Lift Capability . . . . . 20-151

    Bucket Load Capacities . . . . . 20-153

# HARD ROCK Load-Haul-Dumps (LHDs) Articulated Trucks Rock Flow System

20

## CONTENTS

### HARD ROCK

Features	20-3
Load-Haul-Dumps (LHDs):	
Specifications	20-4
Dimensions and Capacities	20-6
Bucket Selection	20-7
Turning Dimensions	20-8
Curves:	
R1300G Rimpull-Speed-Gradeability	20-9
R1600H Rimpull-Speed-Gradeability	20-10
R1700G Rimpull-Speed-Gradeability	20-11
R2900G Rimpull-Speed-Gradeability	20-12
R3000H Rimpull-Speed-Gradeability	20-13
Articulated Trucks:	
Specifications	20-14
Dimensions and Capacities	20-16
Curves:	
AD30 Rimpull-Speed-Gradeability	20-18
AD45B Rimpull-Speed-Gradeability	20-19
AD55 Rimpull-Speed-Gradeability	20-20
AD60 Rimpull-Speed-Gradeability	20-21
LHD and Truck Systems	20-22
Rock Flow System:	
Introduction	20-23
Features	20-23
Specifications:	
Rock Feeder RF300	20-24
Rock Mover RM900	20-24
Rock Straight System:	
Introduction	20-25
Features	20-26
Specifications:	
Hard Rock Miner HRM220	20-27
Hard Rock Conveyor HRC30	20-28
Hard Rock Roof Support HRS1220	20-29

### Features, all models:

- Rugged design for underground application.
- Engineered for productivity, reliability, safety and machine rebuildability.
- Extensive use of steel castings and forgings.
- Cat® heavy duty diesel engines and power trains.
- Computerized machine function monitoring.
- Four wheel enclosed wet disc brakes.
- Remote Control Interface Group options on loaders.
- Payload control system option on loaders.
- Ride control system optional on loaders.
- Fully enclosed air conditioned operator stations available.
- Operator Stations are FOPS certified.

### Product Line:

- Five models of Load-Haul-Dump (LHD) machines, with rated bucket payloads ranging from 6800 kg (14,991 lb) to 20 000 kg (44,100 lb).
- Four models of articulated dump trucks, with payload capacities of 30 000 kg (66,140 lb) to 60 000 kg (132,277 lb).

<b>MODEL</b>	<b>R1300G</b>		<b>R1600H</b>	
Engine Model	<b>3306B</b>		<b>C11 ACERT™</b>	
Gross Power — SAE J1995	123 kW	<b>165 hp</b>	—	—
Gross Power — VR Engine — SAE J1995	—	—	208 kW	<b>279 hp</b>
Gross Power — U.S. EPA Tier 3 equivalent Engine — SAE J1995	—	—	208 kW	<b>279 hp</b>
Tire Size	<b>17.5 × R25</b>		<b>18 × R25</b>	
Nominal Payload Capacity — Tramming	6800 kg	<b>14,991 lb</b>	10 200 kg	<b>22,487 lb</b>
Nominal Payload Capacity — Truck Loading	6800 kg	<b>14,991 lb</b>	10 200 kg	<b>22,487 lb</b>
Gross Machine Mass	27 750 kg	<b>61,178 lb</b>	44 204 kg	<b>97,453 lb</b>
Bucket Size — Minimum	2.4 m <sup>3</sup>	<b>3.1 yd<sup>3</sup></b>	4.2 m <sup>3</sup>	<b>5.5 yd<sup>3</sup></b>
Bucket Size — Maximum	3.4 m <sup>3</sup>	<b>4.4 yd<sup>3</sup></b>	5.9 m <sup>3</sup>	<b>7.7 yd<sup>3</sup></b>
Length — Overall Digging	9107 mm	<b>358.5"</b>	10 107 mm	<b>397.9"</b>
— Overall Tramming	8714 mm	<b>343.1"</b>	9711 mm	<b>382.3"</b>
— Wheel Base	3050 mm	<b>120"</b>	3536 mm	<b>139.2"</b>
Width — Overall with Bucket	2318 mm	<b>91.3"</b>	2723 mm	<b>107.2"</b>
— Overall without Bucket	2071 mm	<b>81.5"</b>	2567 mm	<b>101.1"</b>
— OverTires	1900 mm	<b>74.8"</b>	2404 mm	<b>94.6"</b>
Height — Overall Bucket Raised	4302 mm	<b>169.4"</b>	5204 mm	<b>204.9"</b>
— Maximum Bucket Pin	2918 mm	<b>114.9"</b>	3752 mm	<b>147.7"</b>
— Top of ROPS	2120 mm	<b>83.5"</b>	2400 mm	<b>94.5"</b>
— Dump Clearance	1560 mm	<b>61.4"</b>	2207 mm	<b>86.9"</b>
— Ground Clearance	328 mm	<b>12.9"</b>	344 mm	<b>13.5"</b>
Turning Radius — Outer Clearance	5741 mm	<b>226"</b>	6638 mm	<b>261.3"</b>
— Inner Clearance	2825 mm	<b>111.2"</b>	3291 mm	<b>129.6"</b>
Angle — Articulation	<b>±42.5°</b>		<b>±42.5°</b>	
— Rear Axle Oscillation	<b>±10.0°</b>		<b>±10.0°</b>	
— Maximum Bucket Dump	<b>43°</b>		<b>45°</b>	
Hydraulic Cycle Time:				
Raise	<b>5.0 Sec.</b>		<b>7.6 Sec.</b>	
Dump	<b>2.0 Sec.</b>		<b>1.6 Sec.</b>	
Lower	<b>2.3 Sec.</b>		<b>2.0 Sec.</b>	
Total	<b>9.3 Sec.</b>		<b>11.2 Sec.</b>	
Travel Speeds:	<b>km/h</b>	<b>mph</b>	<b>km/h</b>	<b>mph</b>
Forward — 1st	5.0	<b>3.1</b>	5.0	<b>3.1</b>
— 2nd	9.0	<b>5.6</b>	8.7	<b>5.4</b>
— 3rd	17.0	<b>10.6</b>	15.2	<b>9.5</b>
— 4th	24.0	<b>14.9</b>	22.1	<b>13.7</b>
Reverse — 1st	5.0	<b>3.1</b>	5.7	<b>3.5</b>
— 2nd	8.0	<b>5.0</b>	9.9	<b>6.1</b>
— 3rd	15.0	<b>9.3</b>	17.2	<b>10.7</b>
— 4th	23.0	<b>14.3</b>	23.8	<b>14.8</b>
Tilt Break Out Force SAE	12 020 kg	<b>26,500 lb</b>	17 928 kg	<b>39,524 lb</b>
Lift Break Out Force SAE	11 750 kg	<b>25,909 lb</b>	19 202 kg	<b>42,333 lb</b>
Static Tipping Load — Straight* (\$) — Full Turn* (\$) —	20 575 kg	<b>45,360 lb</b>	25 905 kg	<b>57,110 lb</b>
	17 870 kg	<b>39,397 lb</b>	20 896 kg	<b>46,067 lb</b>
Refill Capacity:				
Fuel	295 L	<b>78 U.S. gal</b>	415/749 L+	<b>109/198 U.S. gal+</b>
Engine Crankcase with Filter	25 L	<b>6.6 U.S. gal</b>	34 L	<b>8.9 U.S. gal</b>
Transmission	45 L	<b>11.9 U.S. gal</b>	47 L	<b>12.4 U.S. gal</b>
Hydraulic Tank	88 L	<b>23.2 U.S. gal</b>	125 L	<b>33 U.S. gal</b>
Cooling System	67 L	<b>17.7 U.S. gal</b>	53 L	<b>14 U.S. gal</b>

\*Static tipping loads shown are for unoptioned standard machines with standard bucket and tires, full fuel tank and operator at 75 kg (165 lb), as per SAE J732 JUN92 5.2.

+Standard fuel tank/With secondary fuel tank.

MODEL	R1700G		R2900G		R3000H	
	C11 ACERT		C15 ACERT		C15 ACERT	
Engine Model						
Gross Power — VR Engine — SAE J1995	263 kW	<b>253 hp</b>	305 kW	<b>409 hp</b>	305 kW	<b>409 hp</b>
Gross Power — Tier 3 equivalent Engine — SAE J1995	242/263+ kW	<b>324/353+ hp</b>	305 kW	<b>409 hp</b>	305 kW	<b>409 hp</b>
Tire Size	<b>26.5 × R25</b>		<b>29.5 × 29</b>		<b>35/65 R33</b>	
Nominal Payload Capacity:						
— Tramming	14 000 kg	<b>30,865 lb</b>	17 200 kg	<b>37,920 lb</b>	20 000 kg	<b>44,092 lb</b>
— Truck Loading	12 500 kg	<b>27,558 lb</b>	17 200 kg	<b>37,920 lb</b>	20 000 kg	<b>44,092 lb</b>
Gross Machine Mass	55 000 kg	<b>121,254 lb</b>	70 350 kg	<b>155,095 lb</b>	80 410 kg	<b>177,273 lb</b>
Bucket Size — Minimum	4.6 m <sup>3</sup>	<b>6.0 yd<sup>3</sup></b>	6.3 m <sup>3</sup>	<b>8.2 yd<sup>3</sup></b>	8.3 m <sup>3</sup>	<b>10.9 yd<sup>3</sup></b>
Bucket Size — Maximum	8.8 m <sup>3</sup>	<b>11.5 yd<sup>3</sup></b>	8.9 m <sup>3</sup>	<b>11.6 yd<sup>3</sup></b>	11.6 m <sup>3</sup>	<b>15.2 yd<sup>3</sup></b>
Length — Overall Digging	10 973 mm	<b>416.9"</b>	11 302 mm	<b>445.0"</b>	11 493 mm	<b>452.5"</b>
— Overall Tramming	10 589 mm	<b>416.9"</b>	10 949 mm	<b>431.1"</b>	11 150 mm	<b>439.0"</b>
— Wheel Base	3680 mm	<b>144.9"</b>	3780 mm	<b>148.8"</b>	3780 mm	<b>148.8"</b>
Width — Overall with Bucket	2894 mm	<b>113.9"</b>	3176 mm	<b>125.0"</b>	3454 mm	<b>136.0"</b>
— Overall without Bucket	2689 mm	<b>105.8"</b>	3010 mm	<b>118.5"</b>	3200 mm	<b>126.0"</b>
— OverTires	2650 mm	<b>104.3"</b>	2898 mm	<b>114.1"</b>	3266 mm	<b>128.6"</b>
Height — Overall Bucket Raised	5606 mm	<b>220.7"</b>	6179 mm	<b>243.3"</b>	6283 mm	<b>247.4"</b>
— Maximum Bucket Pin	4014 mm	<b>161.6"</b>	4539 mm	<b>178.7"</b>	4553 mm	<b>179.3"</b>
— Top of ROPS	2557 mm	<b>100.7"</b>	2886 mm	<b>113.6"</b>	3002 mm	<b>118.2"</b>
— Dump Clearance	2443 mm	<b>96.2"</b>	2868 mm	<b>112.9"</b>	2744 mm	<b>108.0"</b>
— Ground Clearance	429 mm	<b>16.9"</b>	465 mm	<b>18.3"</b>	476 mm	<b>18.7"</b>
Turning Radius — Outer Clearance	6878 mm	<b>270.8"</b>	7323 mm	<b>288.3"</b>	7536 mm	<b>296.7"</b>
— Inner Clearance	3229 mm	<b>127.1"</b>	3383 mm	<b>133.2"</b>	3247 mm	<b>127.8"</b>
Angle — Articulation	<b>±44.0°</b>		<b>±42.5°</b>		<b>±42.5°</b>	
— Rear Axle Oscillation	<b>±8.0°</b>		<b>±8.0°</b>		<b>±8.0°</b>	
— Maximum Bucket Dump	<b>46°</b>		<b>42°</b>		<b>42°</b>	
Hydraulic Cycle Time:						
Raise	<b>6.8 Sec.</b>		<b>9.2 Sec.</b>		<b>8.8 Sec.</b>	
Dump	<b>2.9 Sec.</b>		<b>3.4 Sec.</b>		<b>1.85 Sec.</b>	
Lower	<b>2.4 Sec.</b>		<b>3.1 Sec.</b>		<b>3.5 Sec.</b>	
Total	<b>12.1 Sec.</b>		<b>15.7 Sec.</b>		<b>14.2 Sec.</b>	
Travel Speeds:	<b>km/h</b>	<b>mph</b>	<b>km/h</b>	<b>mph</b>	<b>km/h</b>	<b>mph</b>
Forward — 1st	4.7	<b>2.9</b>	5.4	<b>3.4</b>	5.5	<b>3.4</b>
— 2nd	8.3	<b>5.2</b>	9.7	<b>6.0</b>	9.7	<b>6.0</b>
— 3rd	14.3	<b>8.9</b>	17.3	<b>10.7</b>	17.3	<b>10.7</b>
— 4th	24.1	<b>15.0</b>	29.8	<b>18.5</b>	31.6	<b>19.6</b>
Reverse — 1st	5.4	<b>3.3</b>	6.6	<b>4.1</b>	6.7	<b>4.1</b>
— 2nd	9.4	<b>5.8</b>	11.8	<b>7.3</b>	12.3	<b>7.6</b>
— 3rd	16.4	<b>10.2</b>	21.0	<b>13.0</b>	21.6	<b>13.4</b>
— 4th	25.3	<b>15.7</b>	35.5	<b>22.0</b>	33.8	<b>21.0</b>
Tilt Break Out Force SAE	20 885 kg	<b>46,051 lb</b>	27 346 kg	<b>60,298 lb</b>	28 020 kg	<b>61,784 lb</b>
Lift Break Out Force SAE	10 633 kg	<b>23,446 lb</b>	22 704 kg	<b>50,062 lb</b>	26 817 kg	<b>59,131 lb</b>
Static Tipping Load — Straight*(§)	31 781 kg	<b>70,065 lb</b>	39 923 kg	<b>88,015 lb</b>	47 264 kg	<b>104,199 lb</b>
— Full Turn*(§)	26 306 kg	<b>57,995 lb</b>	34 069 kg	<b>75,109 lb</b>	40 003 kg	<b>88,191 lb</b>
Refill Capacity:						
Fuel	569/ 1015 L++	<b>150.3/268.1 U.S. gal++</b>	1425 L	<b>376.4 U.S. gal</b>	1539 L	<b>406.9 U.S. gal</b>
Engine Crankcase with Filter	34 L	<b>8.98 U.S. gal</b>	34 L	<b>9.0 U.S. gal</b>	34 L	<b>9.0 U.S. gal</b>
Transmission	47 L	<b>12.4 U.S. gal</b>	62 L	<b>16.4 U.S. gal</b>	62 L	<b>16.4 U.S. gal</b>
Hydraulic Tank	125 L	<b>33 U.S. gal</b>	140 L	<b>37.0 U.S. gal</b>	140 L	<b>37.0 U.S. gal</b>
Cooling System	63 L	<b>16.6 U.S. gal</b>	75 L	<b>19.8 U.S. gal</b>	75 L	<b>19.8 U.S. gal</b>

\*Static tipping loads shown are for unoptioned standard machines with standard bucket and tires, full fuel tank and operator at 75 kg (165 lb), as per SAE J732 JUN92 5.2.

+Dual Horsepower — Higher horsepower for different gears (1st-3rd gear/4th gear).

++Standard fuel tank/With secondary fuel tank.

<b>Model</b>	<b>R1300G</b>		<b>R1600H</b>		<b>R1700G</b>	
Nominal Payload Capacity:						
– Tramming	6800 kg	<b>14,991 lb</b>	10 200 kg	<b>22,487 lb</b>	14 000 kg	<b>30,865 lb</b>
– Truck Loading	6800 kg	<b>14,991 lb</b>	10 200 kg	<b>22,487 lb</b>	12 500 kg	<b>27,558 lb</b>
Gross Machine Mass	27 750 kg	<b>61,178 lb</b>	44 204 kg	<b>97,453 lb</b>	55 000 kg	<b>121,254 lb</b>
Bucket Capacity — Standard	3.1 m <sup>3</sup>	<b>4.1 yd<sup>3</sup></b>	4.8 m <sup>3</sup>	<b>6.3 yd<sup>3</sup></b>	5.7 m <sup>3</sup>	<b>7.5 yd<sup>3</sup></b>
Overall Width with Bucket	2318 mm	<b>91.3"</b>	2723 mm	<b>107.2"</b>	2894 mm	<b>113.9"</b>
Overall Height — Top of ROPS	2120 mm	<b>83.5"</b>	2400 mm	<b>94.5"</b>	2557 mm	<b>100.7"</b>
Length — Overall Digging	9107 mm	<b>358.5"</b>	10 107 mm	<b>397.9"</b>	10 973 mm	<b>432.0"</b>
– Overall Tramming	8714 mm	<b>343.1"</b>	9711 mm	<b>382.3"</b>	10 589 mm	<b>416.9"</b>
Operating Weight	20 950 kg	<b>46,187 lb</b>	30 150 kg	<b>66,469 lb</b>	38 500 kg	<b>84,878 lb</b>
Ground Clearance	328 mm	<b>12.9"</b>	344 mm	<b>13.5"</b>	429 mm	<b>16.9"</b>
Axle Oscillation	<b>± 10.0°</b>		<b>± 10.0°</b>		<b>± 8.0°</b>	

<b>Model</b>	<b>R2900G</b>		<b>R3000H</b>	
Nominal Payload Capacity:				
– Tramming	17 200 kg	<b>37,920 lb</b>	20 000 kg	<b>44,092 lb</b>
– Truck Loading	17 200 kg	<b>37,920 lb</b>	20 000 kg	<b>44,092 lb</b>
Gross Machine Mass	70 350 kg	<b>155,095 lb</b>	80 410 kg	<b>177,273 lb</b>
Bucket Capacity — Standard	7.2 m <sup>3</sup>	<b>9.4 yd<sup>3</sup></b>	8.9 m <sup>3</sup>	<b>11.6 yd<sup>3</sup></b>
Overall Width with Bucket	3176 mm	<b>125.0"</b>	3454 mm	<b>136.0"</b>
Overall Height — Top of ROPS	2886 mm	<b>113.6"</b>	3002 mm	<b>118.2"</b>
Length — Overall Digging	11 302 mm	<b>445.0"</b>	11 493 mm	<b>452.5"</b>
– Overall Tramming	10 949 mm	<b>431.1"</b>	11 150 mm	<b>439.0"</b>
Operating Weight	50 209 kg	<b>110,692 lb</b>	56 055 kg	<b>123,580 lb</b>
Ground Clearance	465 mm	<b>18.3"</b>	476 mm	<b>18.7"</b>
Axle Oscillation	<b>± 8.0°</b>		<b>± 8.0°</b>	

<b>Model</b>	<b>Bucket Type</b>	<b>SAE Capacity</b>	
		<b>m<sup>3</sup></b>	<b>yd<sup>3</sup></b>
<b>R1300G</b>	Standard	2.4	<b>3.1</b>
	Standard	2.8	<b>3.6</b>
	Standard	3.1	<b>4.1</b>
	Standard	3.4	<b>4.5</b>
	Ejector	2.4	<b>3.1</b>
<b>R1600H</b>	Standard	4.2	<b>5.5</b>
	Standard	4.8	<b>6.3</b>
	Standard	5.6	<b>7.3</b>
	Standard	5.9	<b>7.7</b>
	Ejector	4.8	<b>6.3</b>
<b>R1700G</b>	Standard*	4.6	<b>6.0</b>
	Standard*	5.0	<b>6.5</b>
	Standard*	5.7	<b>7.5</b>
	Standard*	6.6	<b>8.6</b>
	Standard*	7.3	<b>9.5</b>
	Light Materials Ejector	8.8 5.7	<b>11.5 7.5</b>

<b>Model</b>	<b>Bucket Type</b>	<b>SAE Capacity</b>	
		<b>m<sup>3</sup></b>	<b>yd<sup>3</sup></b>
<b>R2900G</b>	Standard	6.3	<b>8.2</b>
	Standard*	7.2	<b>9.4</b>
	Standard*	8.3	<b>10.9</b>
	Standard*	8.9	<b>11.6</b>
<b>R3000H</b>	Standard*	8.3	<b>10.9</b>
	Standard*	8.9	<b>11.6</b>
	Standard*	10.5	<b>13.7</b>
	Light Materials	11.6	<b>15.2</b>

\*High Penetration Bucket available.

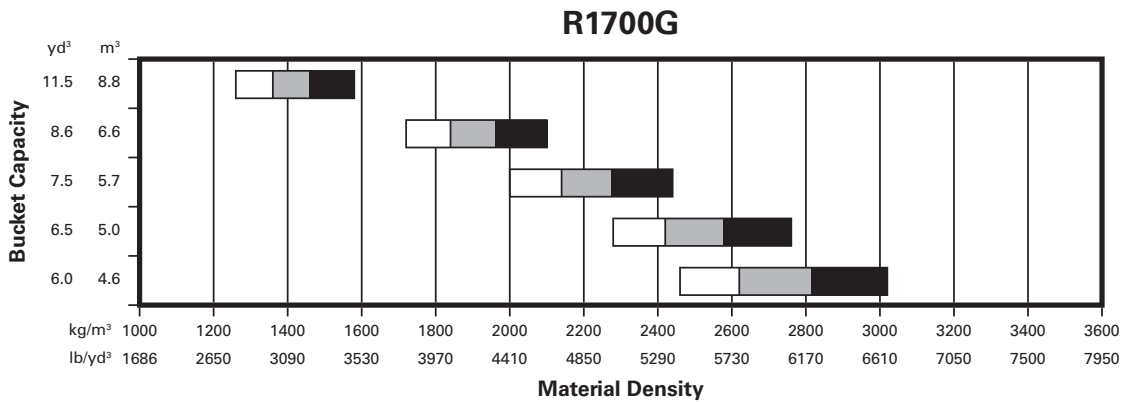
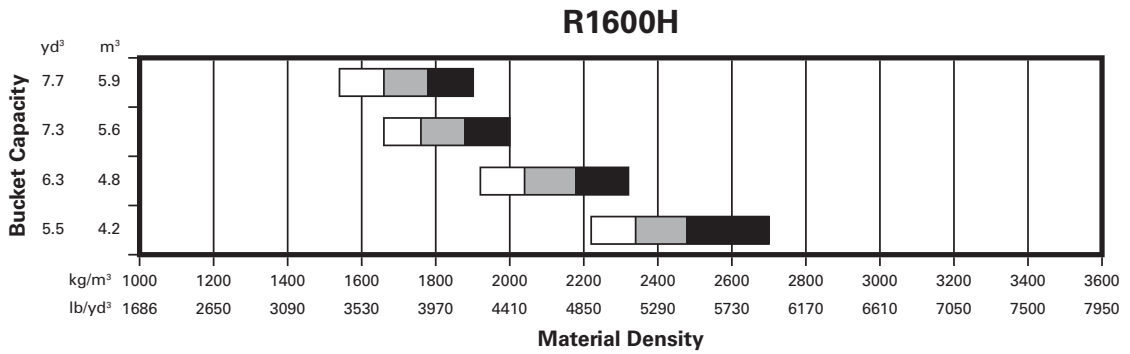
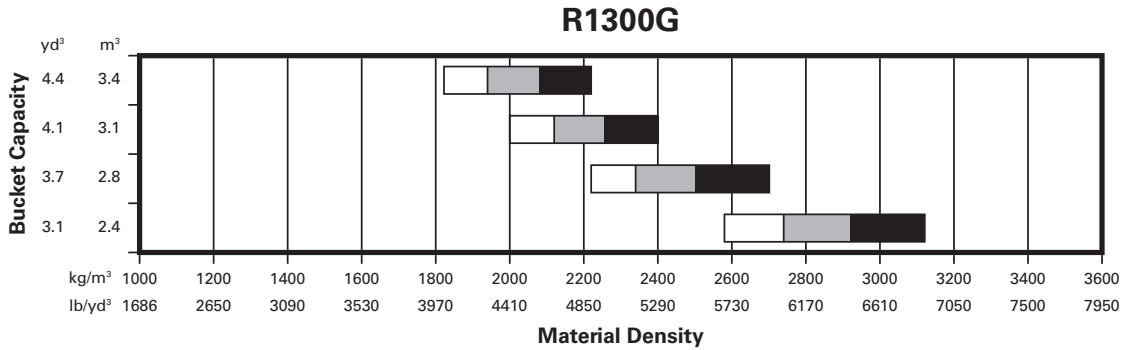

**KEY**

Bucket Fill Factor

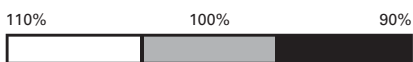

## Hard Rock

### Load-Haul-Dumps (LHDs)

- Bucket Selection
- Turning Dimensions

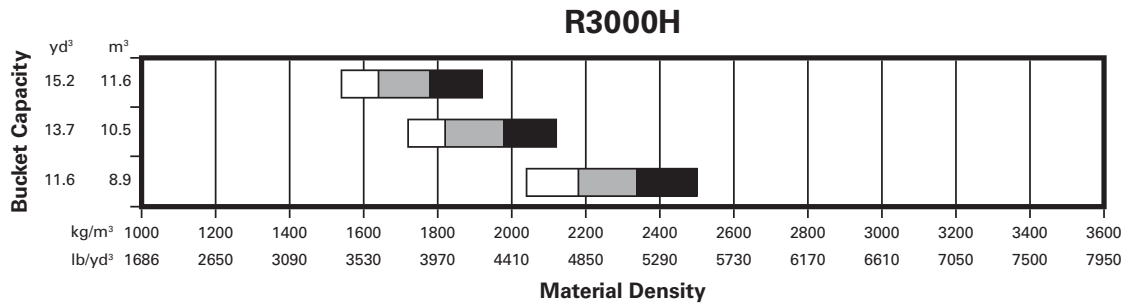
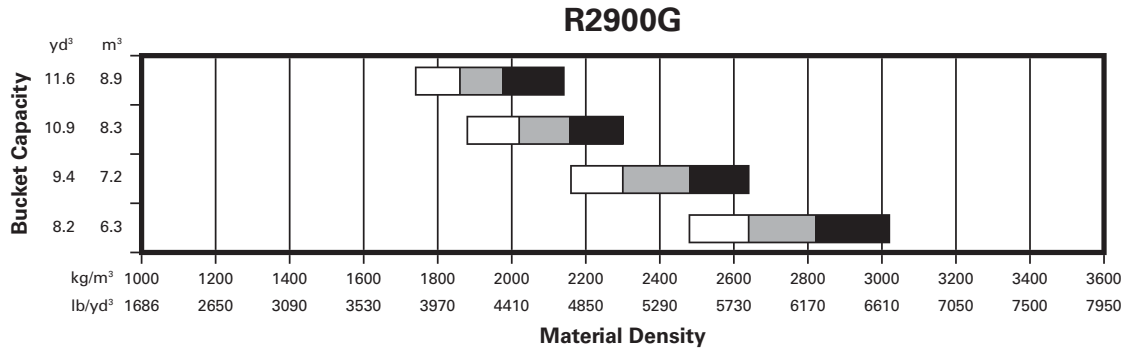

#### KEY

Bucket Fill Factor



#### Turning Dimensions

Model	R1300G		R1600H		R1700G		R2900G		R3000H	
Outer Turning Radius	5741 mm	<b>226"</b>	6638 mm	<b>261.3"</b>	6878 mm	<b>270.8"</b>	7323 mm	<b>288.3"</b>	7536 mm	<b>296.7"</b>
Inner Turning Radius	2825 mm	<b>111.2"</b>	3291 mm	<b>129.6"</b>	3229 mm	<b>127.1"</b>	3383 mm	<b>133.2"</b>	3247 mm	<b>127.8"</b>
Articulation Angle	<b>±42.5°</b>		<b>±42.5°</b>		<b>±44.0°</b>		<b>±42.5°</b>		<b>±42.5°</b>	

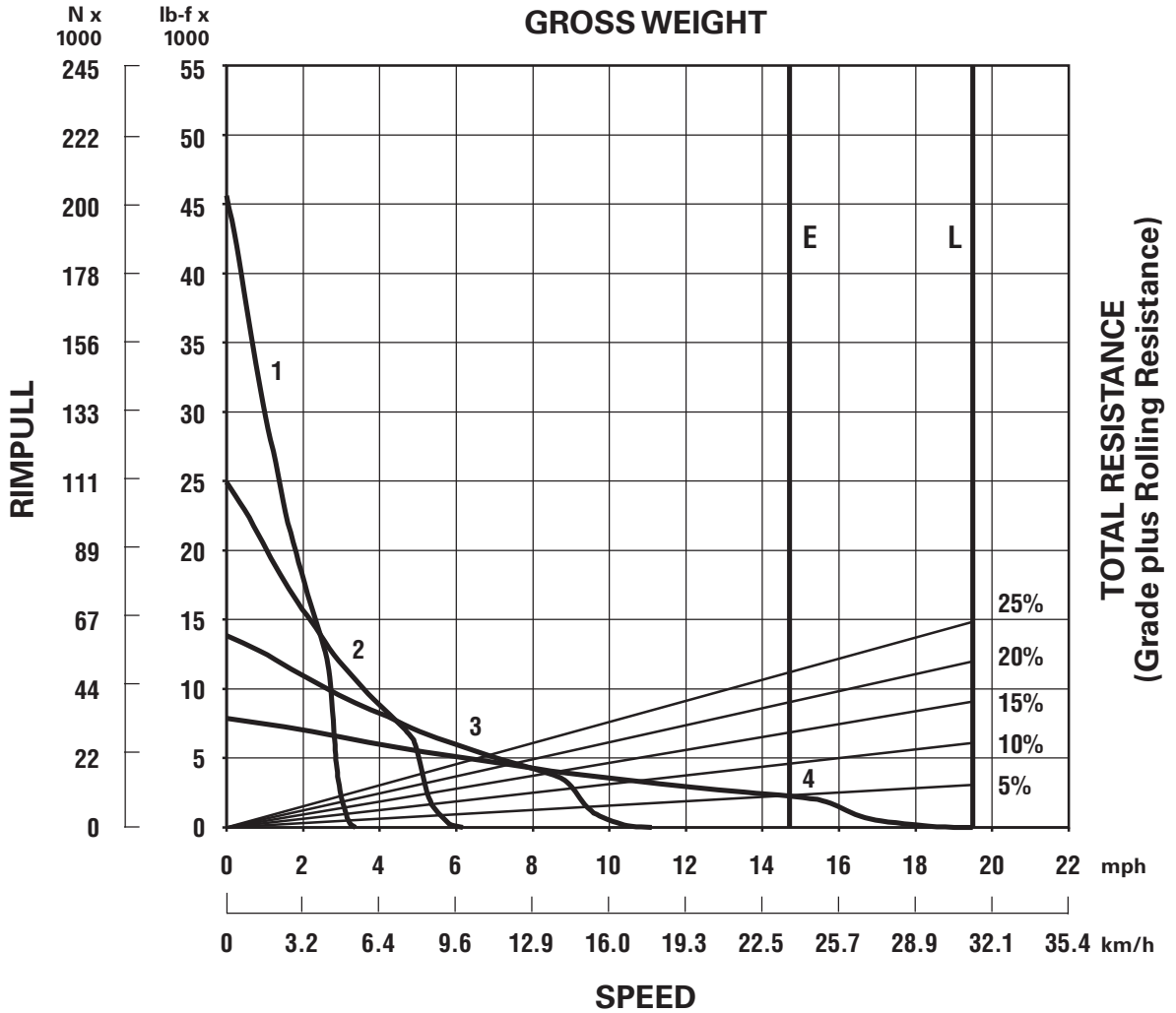

KEY

- 1 — 1st Gear
- 2 — 2nd Gear
- 3 — 3rd Gear
- 4 — 4th Gear

KEY

- E — Empty 20 950 kg (46,187 lb)
- L — Loaded 27 750 kg (61,178 lb)



# Hard Rock

Load-Haul-Dumps (LHDs)

- R1600H 9SD00101 and Up Rimpull-Speed-Gradeability

- 18x25 Tires

## GROSS WEIGHT

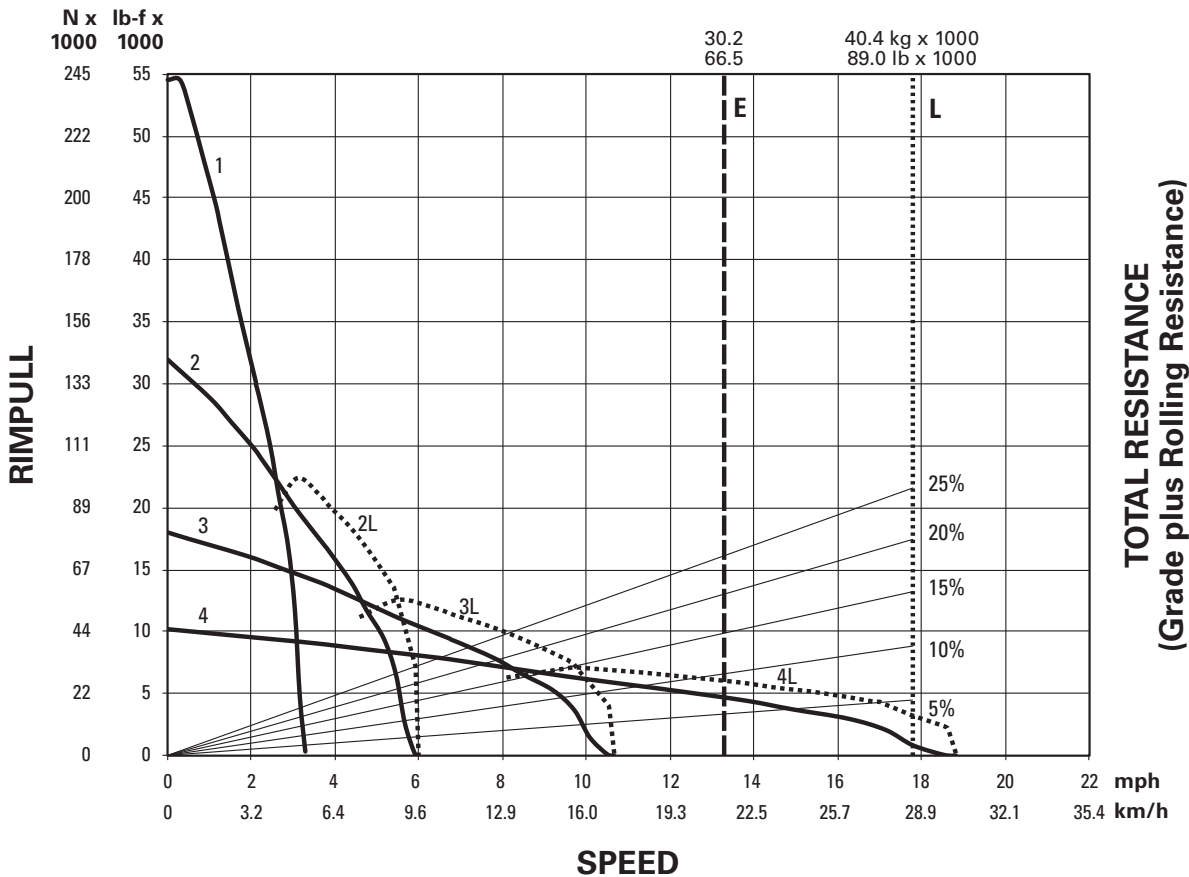

### KEY

- 1 — 1st Gear
- 2 — 2nd Gear
- 2L — 2nd Gear (Lockup Clutch)
- 3 — 3rd Gear
- 3L — 3rd Gear (Lockup Clutch)
- 4 — 4th Gear
- 4L — 4th Gear (Lockup Clutch)

### KEY

- E — Empty 30 150 kg (66,470 lb)
- L — Loaded 40 350 kg (88,956 lb)

- Load-Haul-Dumps (LHDs)
- R1700G Rimpull-Speed-Gradeability
- 26.5x25 Tires

Hard Rock

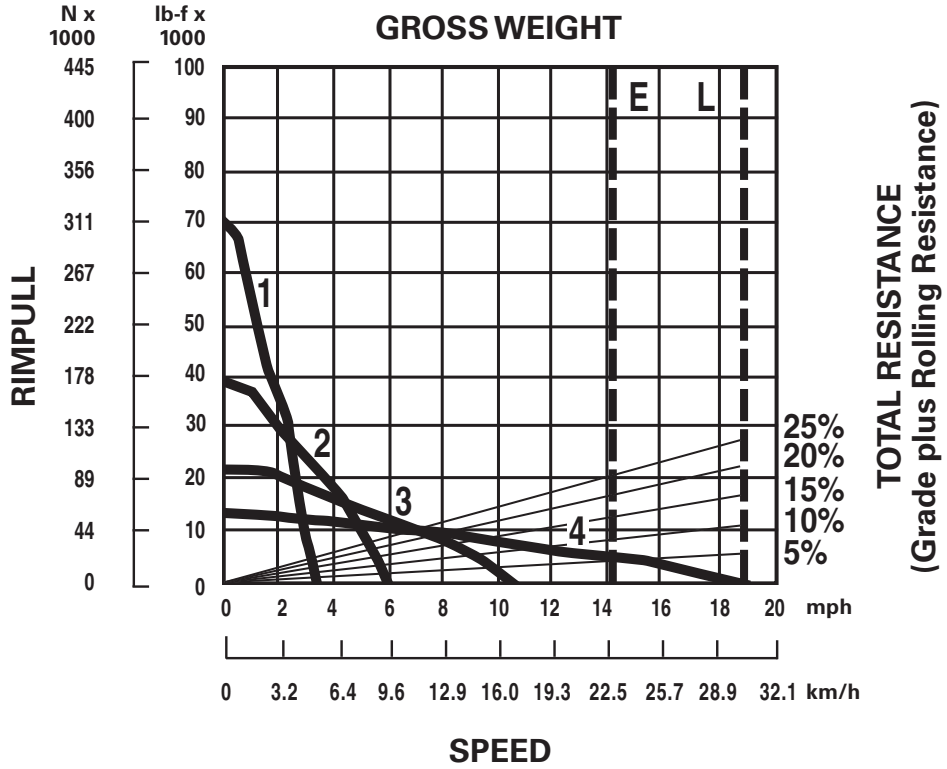

**KEY**

- 1 — 1st Gear
- 2 — 2nd Gear
- 3 — 3rd Gear
- 4 — 4th Gear

**KEY**

- E — Empty 38 500 kg (84,878 lb)
- L — Loaded 51 000 kg (112,436 lb)

# Hard Rock

## Load-Haul-Dumps (LHDs)

- R2900G LUC JLK1203 and 1208 and Up Rimpull-Speed-Gradeability
- 29.5R29 Tires

### GROSS WEIGHT

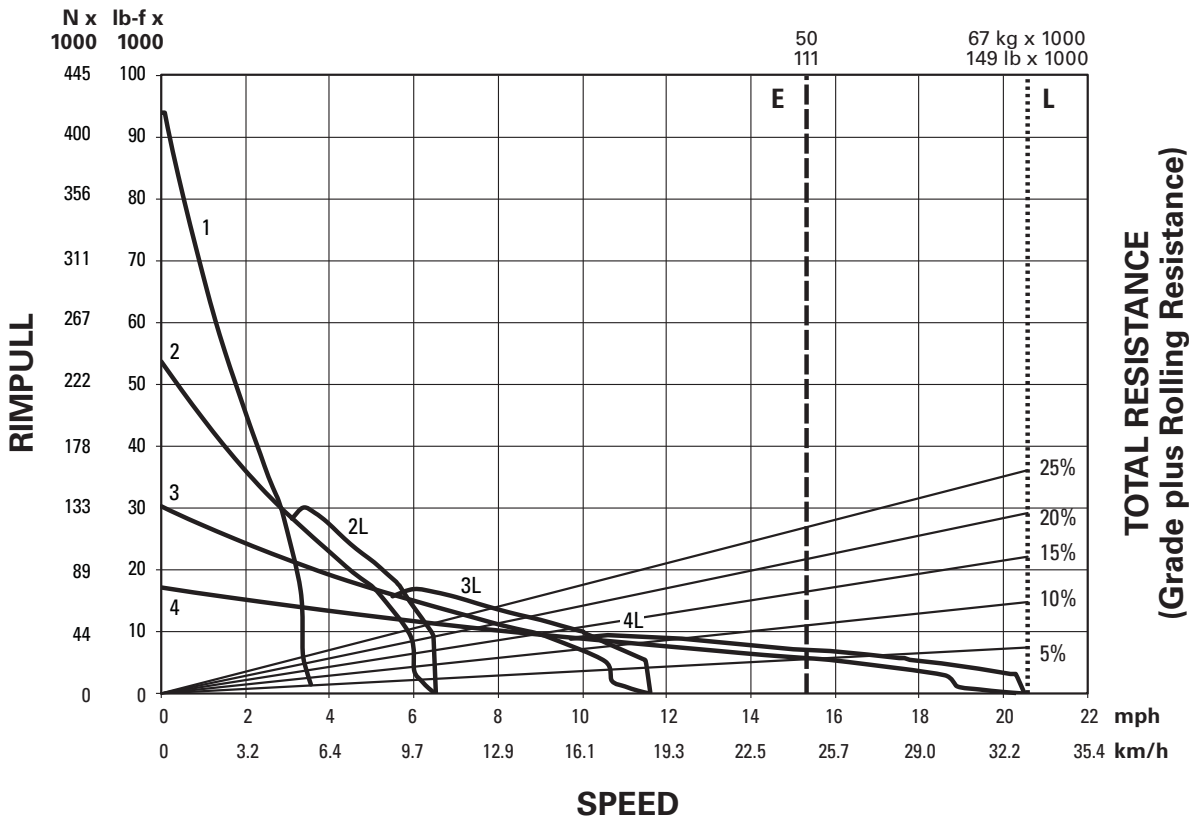

#### KEY

- 1 — 1st Gear
- 2 — 2nd Gear
- 2L — 2nd Gear (Lockup Clutch)
- 3 — 3rd Gear
- 3L — 3rd Gear (Lockup Clutch)
- 4 — 4th Gear
- 4L — 4th Gear (Lockup Clutch)

#### KEY

- E — Empty 50 209 kg (110,692 lb)
- L — Loaded 67 409 kg (148,611 lb)

- Load-Haul-Dumps (LHDs)
- R3000H RCM00101 and Up Rimpull-Speed-Gradeability
- 35/65R33 Tires

Hard Rock

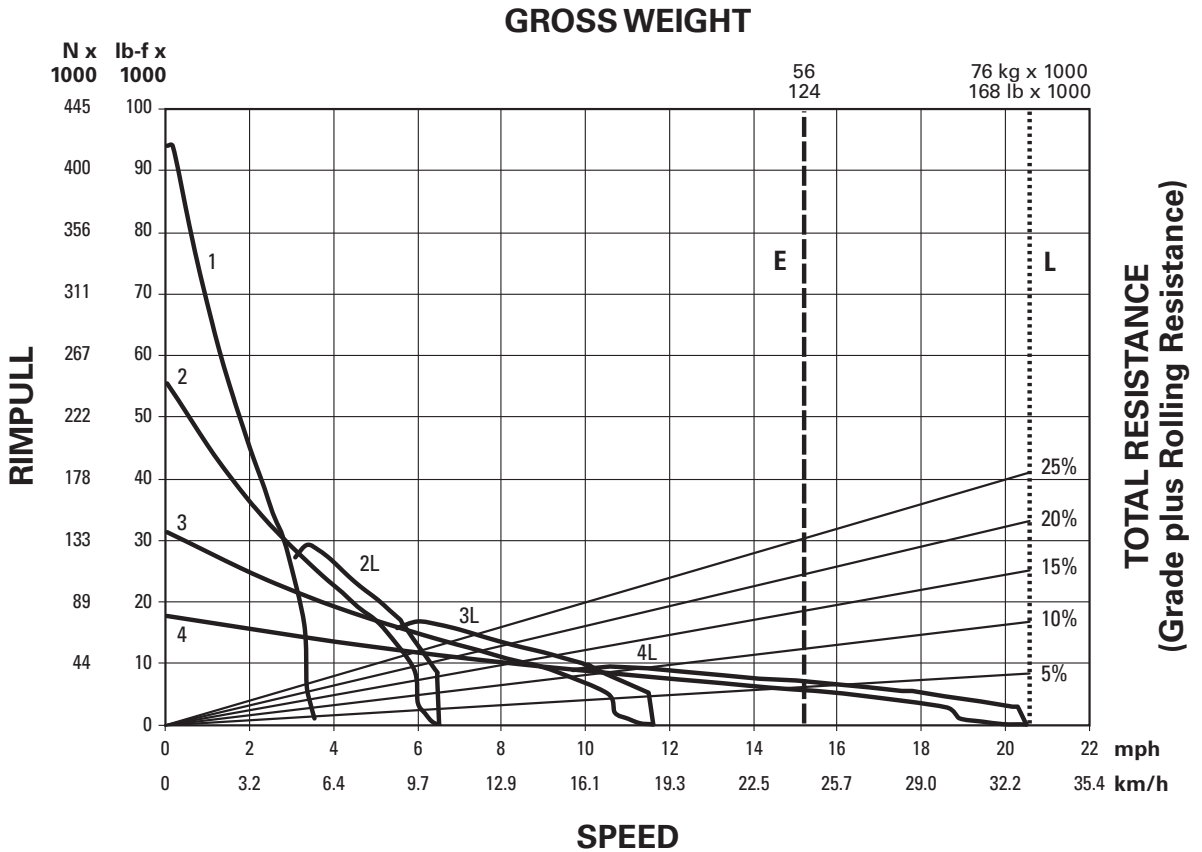

**KEY**

- 1 — 1st Gear
- 2 — 2nd Gear
- 2L — 2nd Gear (Lockup Clutch)
- 3 — 3rd Gear
- 3L — 3rd Gear (Lockup Clutch)
- 4 — 4th Gear
- 4L — 4th Gear (Lockup Clutch)

**KEY**

- E — Empty 56 055 kg (123,580 lb)
- L — Loaded 76 055 kg (167,672 lb)

<b>MODEL</b>	<b>AD30</b>		<b>AD45B</b>	
	<b>C15 ACERT</b>		<b>C18 ACERT</b>	
Engine Model				
Engine Power:				
– Gross Power – VR Engine – SAE J1995	305 kW	<b>409 hp</b>	439 kW	<b>589 hp</b>
– Gross Power – Tier 3 equivalent Engine – SAE J1995	305 kW	<b>409 hp</b>	439 kW	<b>589 hp</b>
Tire Size	<b>26.5 × R25</b>		<b>29.5 × R29</b>	
Nominal Payload Capacity	30 000 kg	<b>66,138 lb</b>	45 000 kg	<b>99,208 lb</b>
Gross Machine Operating Weight	60 000 kg	<b>132,277 lb</b>	85 000 kg	<b>187,393 lb</b>
Body Capacity* – Standard Dump Body	14.4 m <sup>3</sup>	<b>18.8 yd<sup>3</sup></b>	21.3 m <sup>3</sup>	<b>27.9 yd<sup>3</sup></b>
Weight Distribution:				
– Empty (Front/Rear)	<b>67.5%/32.5%</b>		<b>69.0%/31.0%</b>	
– Loaded (Front/Rear)	<b>44.2%/55.8%</b>		<b>45.6%/54.4%</b>	
Length – Overall	10 153 mm	<b>399.7"</b>	11 194 mm	<b>440.7"</b>
Width – Overall	2690 mm	<b>105.9"</b>	3000 mm	<b>118.1"</b>
Height:				
– Overall Body Raised	5602 mm	<b>220.5"</b>	6357 mm	<b>250.3"</b>
– Top of ROPS	2600 mm	<b>102.4"</b>	2817 mm	<b>110.9"</b>
– Loading Height	2385 mm	<b>93.9"</b>	2925 mm	<b>115.2"</b>
– Ground Clearance	400 mm	<b>15.7"</b>	441 mm	<b>17"</b>
Clearance Radius:				
– Outer Clearance	8571 mm	<b>337.7"</b>	9291 mm	<b>365.8"</b>
– Inner Clearance	5030 mm	<b>198"</b>	5310 mm	<b>209"</b>
Angle:				
– Articulation	<b>±42.5°</b>		<b>±42.5°</b>	
– Oscillation	<b>±10.0°</b>		<b>±10.0°</b>	
Body Hoist Cycle Time:				
Raise Time	<b>10.5 Sec.</b>		<b>16.0 Sec.</b>	
Dump Time	<b>11.2 Sec.</b>		<b>21.0 Sec.</b>	
Total Cycle Time	<b>21.7 Sec.</b>		<b>37.0 Sec.</b>	
Travel Speeds:	<b>km/h</b>	<b>mph</b>	<b>km/h</b>	<b>mph</b>
Forward – 1st	6.8	<b>4.2</b>	8.0	<b>4.9</b>
– 2nd	12.3	<b>7.6</b>	10.9	<b>6.8</b>
– 3rd	22.3	<b>13.9</b>	15.1	<b>9.4</b>
– 4th	40.8	<b>25.4</b>	20.6	<b>12.8</b>
– 5th	–	–	28.1	<b>17.5</b>
– 6th	–	–	38.1	<b>23.7</b>
– 7th	–	–	52.0	<b>32.3</b>
Reverse – 1st	7.8	<b>4.8</b>	7.5	<b>4.6</b>
– 2nd	–	–	10.1	<b>6.3</b>
Refill Capacity:				
Fuel	500 L	<b>132 U.S. gal</b>	764 L	<b>202 U.S. gal</b>
Engine Crankcase with Filter	38 L	<b>10 U.S. gal</b>	64 L	<b>17 U.S. gal</b>
Transmission	67 L	<b>18 U.S. gal</b>	60 L	<b>16 U.S. gal</b>
Hydraulic Tank	145 L	<b>38 U.S. gal</b>	266 L	<b>70 U.S. gal</b>
Cooling System	76 L	<b>20 U.S. gal</b>	85 L	<b>23 U.S. gal</b>

\*Heaped SAE 2:1.

MODEL	AD55		AD60	
	C18 ACERT		C27 ACERT	
Engine Model				
Engine Power:				
– Gross Power – VR Engine – SAE J1995	439 kW	<b>589 hp</b>	600 kW	<b>805 hp</b>
– Gross Power – Tier 3 equivalent Engine – SAE J1995	439 kW	<b>589 hp</b>	540/560 kW+	<b>725/751 hp+</b>
Tire Size	<b>35 × 65 R33</b>		<b>35 × 65 R33</b>	
Nominal Payload Capacity	55 000 kg	<b>121,254 lb</b>	60 000 kg	<b>132,277 lb</b>
Gross Machine Operating Weight	102 000 kg	<b>226,871 lb</b>	112 000 kg	<b>246,917 lb</b>
Body Capacity* – Dump Body	26.9 m <sup>3</sup>	<b>35.2 yd<sup>3</sup></b>	26.9 m <sup>3</sup>	<b>35.2 yd<sup>3</sup></b>
Weight Distribution:				
– Empty (Front/Rear)	<b>66.4%/34.2%</b>		<b>70.5%/29.5%</b>	
– Loaded (Front/Rear)	<b>47.6%/53.4%</b>		<b>50.0%/50.0%</b>	
Length – Overall	11 523 mm	<b>454"</b>	12 040 mm	<b>474"</b>
Width – Overall	3250 mm	<b>128"</b>	3346 mm	<b>131.7"</b>
Height:				
– Overall Body Raised	6969 mm	<b>274"</b>	6969 mm	<b>274.4"</b>
– Top of ROPS	3000 mm	<b>118"</b>	3000 mm	<b>118.1"</b>
– Loading Height	3045 mm	<b>120"</b>	3045 mm	<b>119.9"</b>
– Ground Clearance	391 mm	<b>15"</b>	393 mm	<b>15.5"</b>
Clearance Radius:				
– Outer	9885 mm	<b>389"</b>	10 005 mm	<b>393.9"</b>
– Inner	5540 mm	<b>218"</b>	5540 mm	<b>218.1"</b>
Angle:				
– Articulation	<b>±42.5°</b>		<b>±42.5°</b>	
– Oscillation	<b>±10.0°</b>		<b>±10.0°</b>	
Body Hoist Cycle Time:				
– Raise Time	<b>12.0 Sec.</b>		<b>12.0 Sec.</b>	
– Dump Time	<b>24.0 Sec.</b>		<b>24.0 Sec.</b>	
– Total Cycle Time	<b>36.0 Sec.</b>		<b>36.0 Sec.</b>	
Travel Speeds:	<b>km/h</b>	<b>mph</b>	<b>km/h</b>	<b>mph</b>
Forward – 1st	7.0	<b>4.4</b>	6.6	<b>4.1</b>
– 2nd	9.6	<b>5.9</b>	9.3	<b>5.8</b>
– 3rd	13.0	<b>8.1</b>	12.5	<b>7.5</b>
– 4th	17.5	<b>10.8</b>	16.8	<b>10.4</b>
– 5th	23.7	<b>14.7</b>	22.7	<b>14.1</b>
– 6th	31.9	<b>19.8</b>	30.7	<b>19.1</b>
– 7th	43.3	<b>26.9</b>	41.5	<b>25.8</b>
Reverse – 1st	6.8	<b>4.2</b>	8.7	<b>5.4</b>
– 2nd	9.2	<b>5.7</b>	–	–
Refill Capacity:				
– Fuel	940 L	<b>248.3 U.S. gal</b>	856 L	<b>226.1 U.S. gal</b>
– Engine Crankcase with Filter	64 L	<b>17 U.S. gal</b>	99 L	<b>26 U.S. gal</b>
– Transmission	53 L	<b>14 U.S. gal</b>	53 L	<b>14 U.S. gal</b>
– Hydraulic Tank	258 L	<b>68 U.S. gal</b>	258 L	<b>68 U.S. gal</b>
– Cooling System	75 L	<b>20 U.S. gal</b>	138 L	<b>37 U.S. gal</b>

\*Heaped SAE 2:1.

+Dual Horsepower – Higher horsepower for different gears.

**Articulated Trucks**

<b>Model</b>	<b>AD30</b>		<b>AD45B</b>	
Nominal Payload Capacity	30 000 kg	<b>66,138 lb</b>	45 000 kg	<b>99,208 lb</b>
Gross Machine Operating Weight	60 000 kg	<b>132,277 lb</b>	85 000 kg	<b>187,393 lb</b>
Body Capacity* — Standard Dump Body	14.4 m <sup>3</sup>	<b>18.8 yd<sup>3</sup></b>	21.3 m <sup>3</sup>	<b>27.9 yd<sup>3</sup></b>
Overall Length	10 153 mm	<b>399.7"</b>	11 194 mm	<b>440.7"</b>
Overall Width	2690 mm	<b>105.9"</b>	3000 mm	<b>118.1"</b>
Overall Height	2600 mm	<b>102.4"</b>	3036 mm	<b>119.5"</b>
Ground Clearance	400 mm	<b>15.7"</b>	441 mm	<b>17"</b>
Frame Oscillation	<b>±10.0°</b>		<b>±10.0°</b>	

<b>Model</b>	<b>AD55</b>		<b>AD60</b>	
Nominal Payload Capacity	55 000 kg	<b>121,254 lb</b>	60 000 kg	<b>132,277 lb</b>
Gross Machine Operating Weight	102 000 kg	<b>226,871 lb</b>	112 000 kg	<b>246,917 lb</b>
Body Capacity* — Dump Body	26.9 m <sup>3</sup>	<b>35.2 yd<sup>3</sup></b>	26.9 m <sup>3</sup>	<b>35.2 yd<sup>3</sup></b>
Overall Length	11 523 mm	<b>454"</b>	12 040 mm	<b>474"</b>
Overall Width	3250 mm	<b>128"</b>	3346 mm	<b>131.7"</b>
Overall Height	3000 mm	<b>118"</b>	3202 mm	<b>126.1"</b>
Ground Clearance	391 mm	<b>15"</b>	393 mm	<b>15.5"</b>
Frame Oscillation	<b>±10.0°</b>		<b>±10.0°</b>	

\*2:1 per SAE.

<b>Model</b>	<b>Body Type</b>	<b>SAE Body Capacity</b>	
		<b>m<sup>3</sup></b>	<b>yd<sup>3</sup></b>
<b>AD30</b>	Dump	11.3	<b>14.8</b>
	Dump	14.4	<b>18.8</b>
	Dump	17.5	<b>22.9</b>
	Wide Body	16.8	<b>21.9</b>
	Ejector Body	15.2	<b>19.9</b>
	Ejector Body	16.8	<b>21.9</b>
<b>AD45B</b>	Dump	18.0	<b>23.5</b>
	Dump	21.3	<b>27.9</b>
	Dump	25.1	<b>32.8</b>
	Ejector Body	22.9	<b>29.9</b>

<b>Model</b>	<b>Body Type</b>	<b>SAE Body Capacity</b>	
		<b>m<sup>3</sup></b>	<b>yd<sup>3</sup></b>
<b>AD55</b>	Dump	26.9	<b>35.2</b>
	Dump	32.6	<b>42.6</b>
	Dump	33.8	<b>44.2</b>
	Dump	36.6	<b>47.9</b>
<b>AD60</b>	Dump	26.9	<b>35.2</b>
	Dump	32.6	<b>42.6</b>
	Dump	33.8	<b>44.2</b>
	Ejector Body	26.9	<b>35.2</b>
Ejector Body	29.4	<b>38.5</b>	

## Turning Dimensions

### Articulated Trucks

<b>Model — Standard Body</b>	<b>AD30</b>		<b>AD45B</b>	
Clearance Radius — Outer	8571 mm	337.4"	9291 mm	365.8"
Clearance Radius — Inner	5030 mm	198.0"	5310 mm	209.0"
Angle — Articulation	±42.5°		±42.5°	

<b>Model — Standard Body</b>	<b>AD55</b>		<b>AD60</b>	
Clearance Radius — Outer	9885 mm	389.0"	10 005 mm	393.9"
Clearance Radius — Inner	5540 mm	218.1"	5540 mm	218.1"
Angle — Articulation	±42.5°		±42.5°	

<b>Model — Ejector Body</b>	<b>AD30</b>		<b>AD45B</b>	
Clearance Radius — Outer	8571 mm	337.5"	9291 mm	365.8"
Clearance Radius — Inner	4935 mm	194.3"	5210 mm	205.0"
Angle — Articulation	±42.5°		±42.5°	

<b>Model — Ejector Body</b>	<b>AD55</b>		<b>AD60</b>	
Clearance Radius — Outer	N/A		10 005 mm	393.9"
Clearance Radius — Inner	N/A		5419 mm	213.4"
Angle — Articulation	N/A		±42.5°	

N/A = Not Available



**Hard Rock**

**Articulated Trucks**

- AD30 Rimpull-Speed-Gradeability
- 26.5R25 Tires

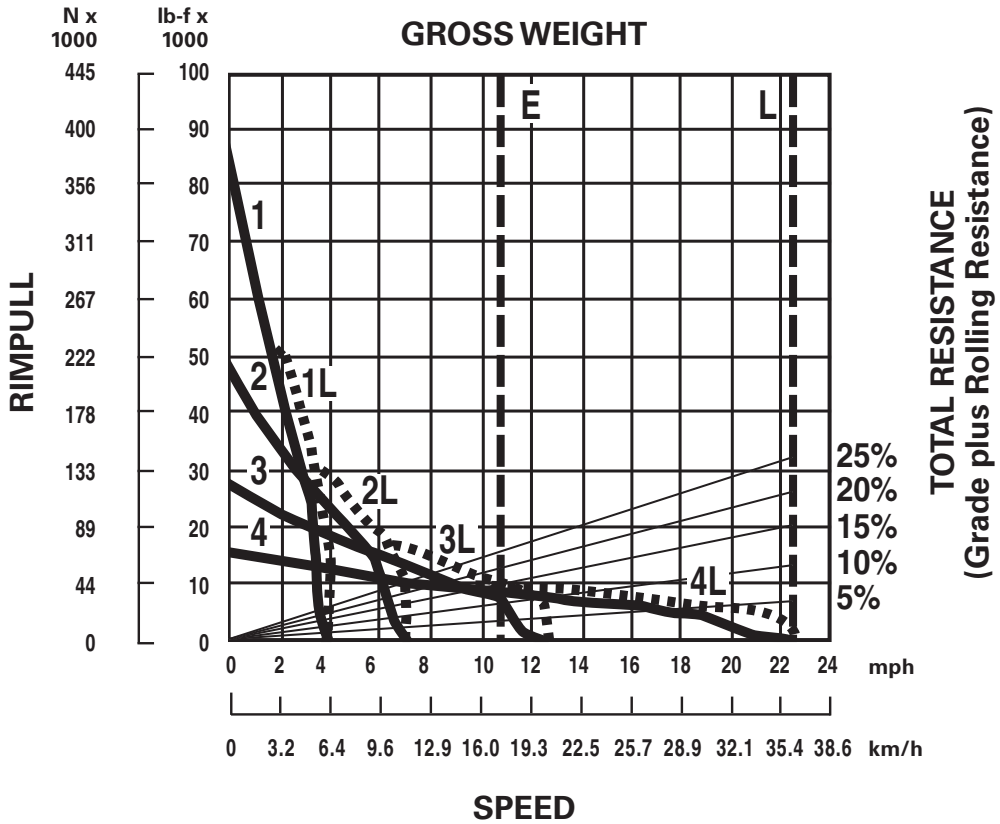

**KEY**

- 1 – 1st Gear
- 2 – 2nd Gear
- 3 – 3rd Gear
- 4 – 4th Gear

**KEY**

- E – Empty 28 870 kg (63,647 lb)
- L – Loaded 60 000 kg (132,277 lb)

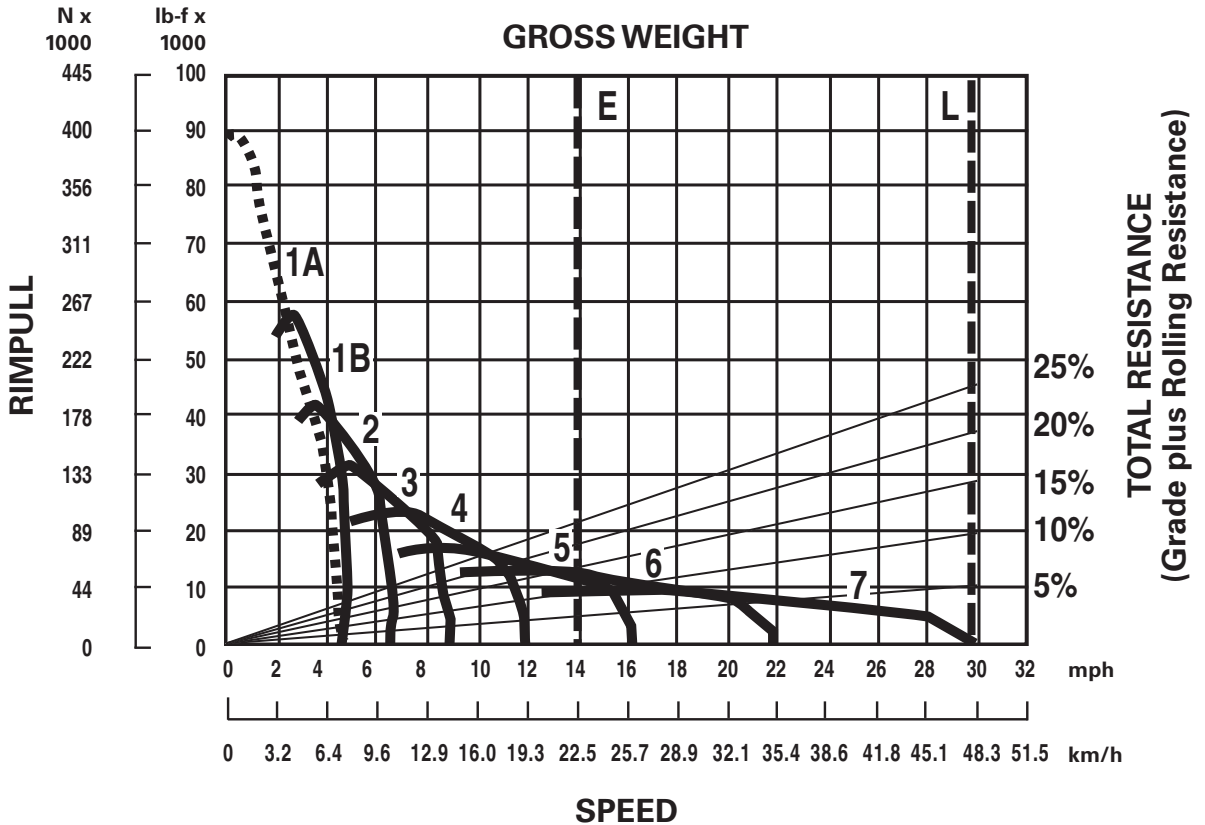

- KEY**
- 1A — 1st Gear Torque Converter Drive
  - 1B — 1st Gear Direct Drive
  - 2 — 2nd Gear Direct Drive
  - 3 — 3rd Gear Direct Drive
  - 4 — 4th Gear Direct Drive
  - 5 — 5th Gear Direct Drive
  - 6 — 6th Gear Direct Drive
  - 7 — 7th Gear Direct Drive

- KEY**
- E — Empty 40 000 kg (88,185 lb)
  - L — Loaded 85 000 kg (187,393 lb)

**Hard Rock**

- Articulated Trucks
- AD55 Rimpull-Speed-Gradeability
- 35/65R33 Tires

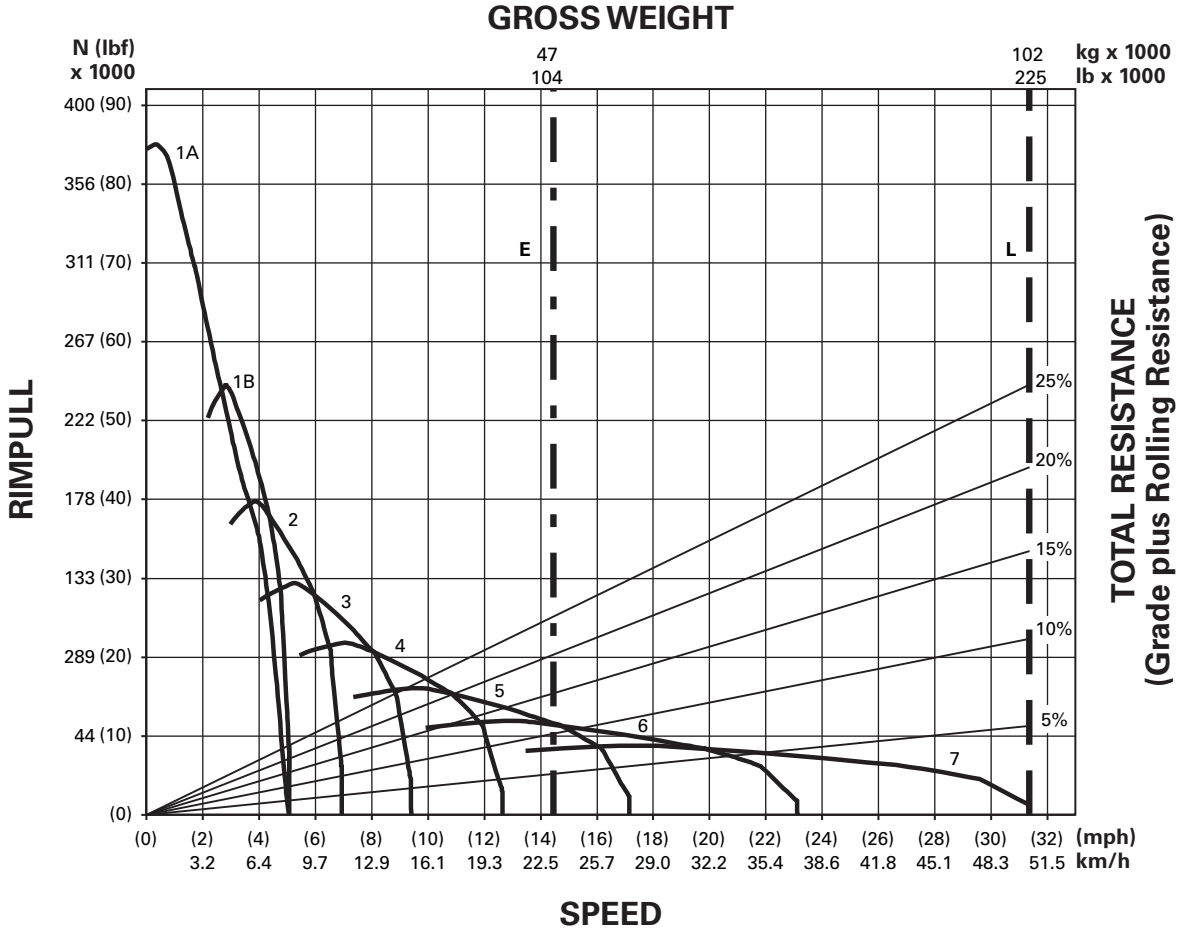

**KEY**

- 1A — 1st Gear Converter Drive
- 1B — 1st Gear
- 2 — 2nd Gear
- 3 — 3rd Gear
- 4 — 4th Gear
- 5 — 5th Gear
- 6 — 6th Gear
- 7 — 7th Gear

**KEY**

- E — Empty 47 000 kg (103,617 lb)
- L — Loaded 102 000 kg (224,871 lb)

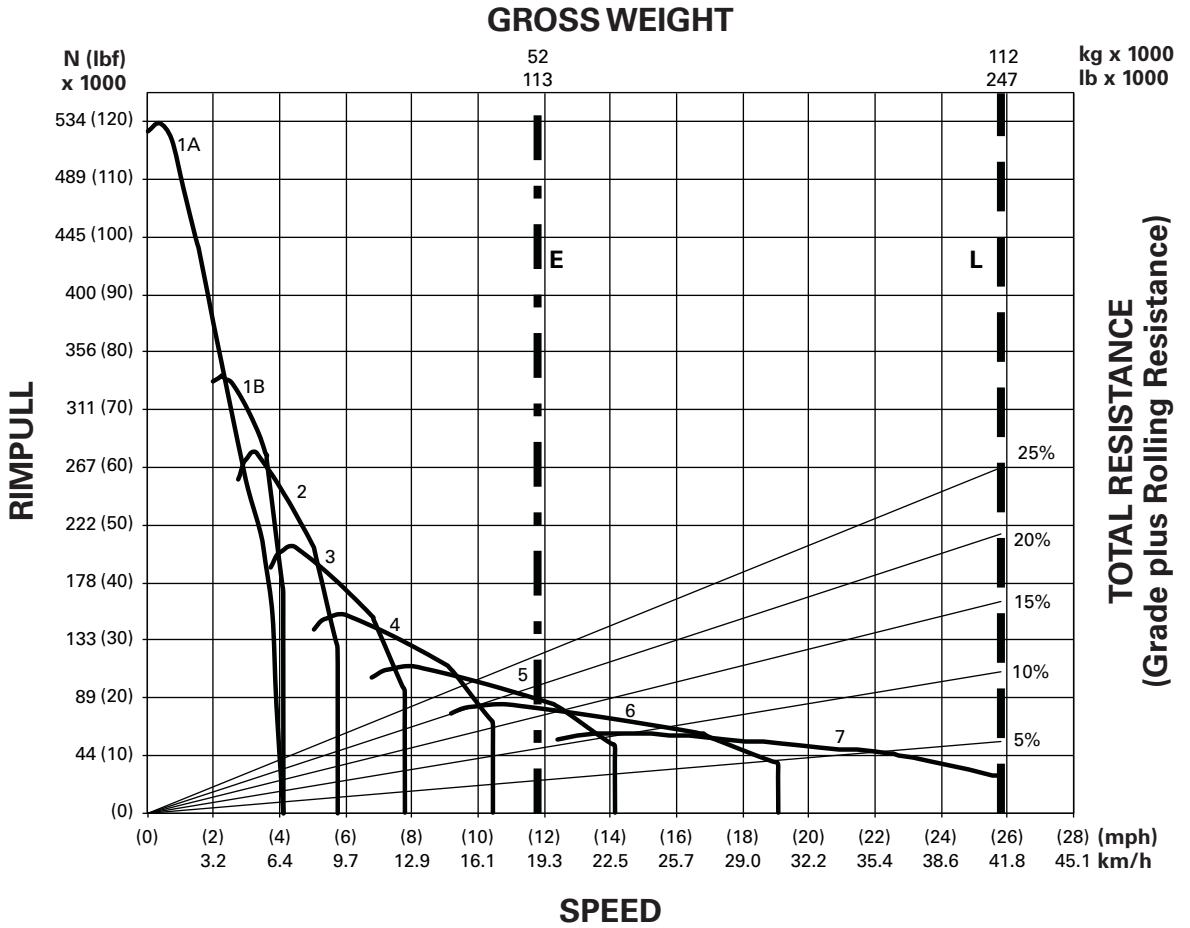

- KEY**
- 1A — 1st Gear (Converter Drive)
  - 1B — 1st Gear
  - 2 — 2nd Gear
  - 3 — 3rd Gear
  - 4 — 4th Gear
  - 5 — 5th Gear
  - 6 — 6th Gear
  - 7 — 7th Gear

- KEY**
- E — Empty 51 200 kg (112,876 lb)
  - L — Loaded 112 000 kg (246,917 lb)

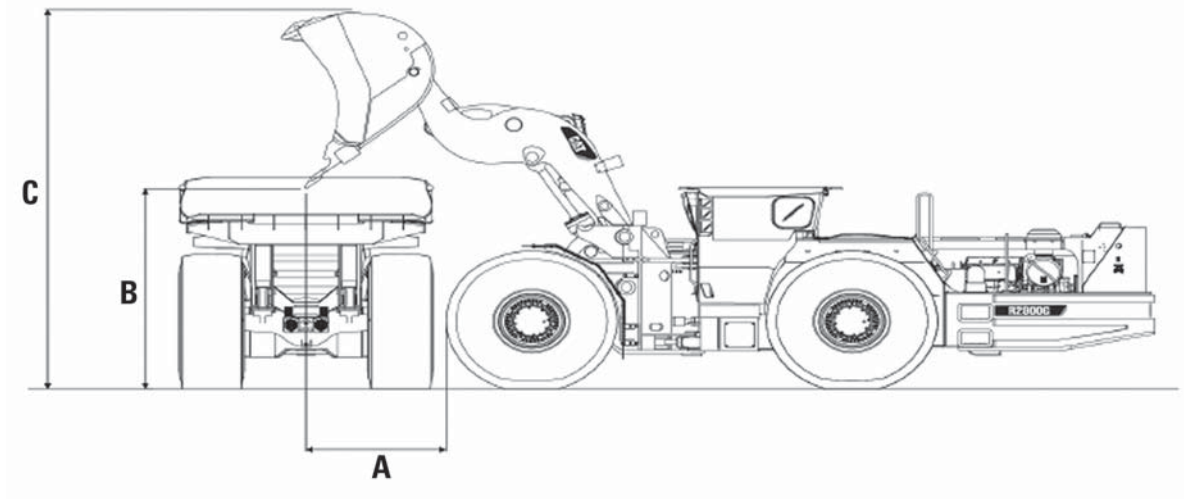

Loader	Target	A		B		C	
R1300G	AD30	1583 mm	62"	1560 mm	61"	3531 mm	139"
R1600H	AD30	1408 mm	55"	2207 mm	87"	4497 mm	177"
R1600H	AD45B	1408 mm	55"	2207 mm	87"	4497 mm	177"
R1700G	AD30	1738 mm	68"	2443 mm	96"	4884 mm	192"
R1700G	AD45B	1741 mm	68"	2443 mm	96"	4884 mm	192"
R1700G	AD55	1785 mm	70"	2443 mm	96"	4884 mm	192"
R2900G	AD45B	1656 mm	65"	2868 mm	113"	6179 mm	243"
R2900G	AD55	1656 mm	65"	2868 mm	113"	6179 mm	243"
R2900G	AD60	1656 mm	65"	2868 mm	113"	6179 mm	243"
R3000H	AD45B	1789 mm	70"	2868 mm	113"	5429 mm	213"
R3000H	AD55	1789 mm	70"	2744 mm	108"	5429 mm	213"
R3000H	AD60	1789 mm	70"	2744 mm	108"	5429 mm	213"

NOTE: R1700G rated payload 14 000 kg (30,870 lb) is for tramping only. Truck loading capacity is 12 500 kg (27,563 lb).

## ROCK FLOW SYSTEM

### Introduction

The innovative Cat Rock Flow System is a continuous production system for block caving operations. This special mining system combines the usage of a Rock Feeder, a Rock Mover and an automation system to deliver mass mining production with improved safety and sustainability.

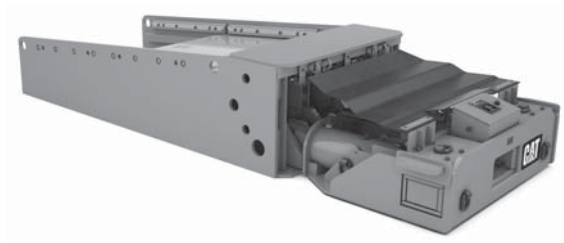

The Rock Feeder RF300 extracts ore from the draw-point onto a Rock Mover [Hard Rock Chain Conveyor] by a hydraulically operated push plate.

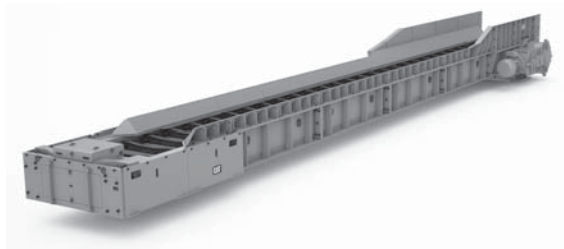

The Rock Mover RM900 is a dedicated hard rock production conveyor that collects ore from various draw-points. The Rock Flow Automation System (featuring remote operation from surface) allows draw and quality control and records operational data.

### Features

- Continuous mass mining production system increases productivity.
- Highly automated system providing real time draw control.
- Easy maintenance and clearance work.
- Use of electric drives increases safety, reduces cost and improves underground climate and carbon footprint.

## Hard Rock

### Rock Flow System Specifications

- Rock Feeder RF300
- Rock Mover RM900

#### Rock Feeder

#### RF300

Performance	300 tonnes/hr	<b>331 tons/hr</b>
Dimensions (L x W x H)	4300 mm x 2000 mm x 1050 mm	<b>14.1' x 6.6' x 3.4'</b>
Weight — Total RF300	22.0 tonnes	<b>24.3 tons</b>
Dozer Plate Cylinder:		
Quantity	<b>4</b>	
Stroke	1350 mm	<b>4.4'</b>
Cycle Time	<b>120 Sec.</b>	
Pressure — Total	4021 kN	<b>903,956 lbf</b>
Pushing Cylinders:		
Quantity	<b>2</b>	
Stroke	600 mm	<b>2'0"</b>
Pressure — Total	5147 kN	<b>1,157,092 lbf</b>
Weight — Pushing Device	5.8 tonnes	<b>6.4 tons</b>

#### Rock Mover

#### RM900

Performance	900 tonnes/hr	<b>992 tons/hr</b>
Chain Speed	0.15 m/sec	<b>29.5 ft/min</b>
Drive Power	2 x 75 kW	<b>2 x 102 hp</b>
Pan Width	1800 mm	<b>5.9'</b>
Pan Length	3000 mm	<b>9.8'</b>
Conveyor Length	77 m	<b>252'0"</b>
Chain Size	42 mm x 146 mm	<b>1.65" x 5.75"</b>
Hydraulic Return Unit:		
Option 1:	<b>Manually adjustable unpowered</b>	
Option 2:	<b>Fully activated</b>	

## ROCK STRAIGHT SYSTEM

### Introduction

The Cat Rock Straight System is a fully mechanized longwall system adopted to hard rock conditions for continuous mining of flat and tabular deposits and reefs. The Rock Straight System combines the use of a hard rock shearer (Hard Rock Miner HRM220), a hard rock chain conveyor (Hard Rock Conveyor HRC30) and hydraulic roof support (Hard Rock Roof Support HRS1220). It features the adaptation of the newly developed “Cat Activated Undercutting Technology” and has been particularly designed for the extraction of bedded hard rock deposits (e.g. copper, gold).

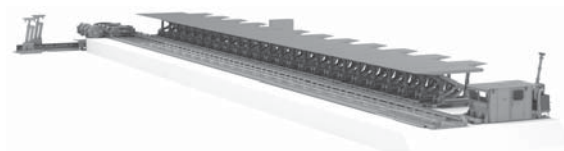

The Rock Straight System particularly provides economical cutting in the mining of thin seams and narrow veins, especially when selective mining of ore is required.

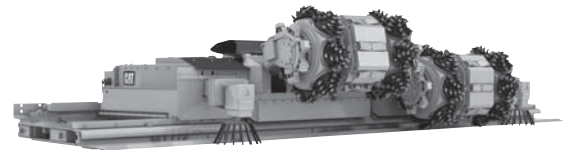

The powerful Hard Rock Miner HRM220 is designed for continuous cutting operation in low seam heights of between 1.3 to 2.0 m (4.2 to 6.6 ft). The two cutting units can be adjusted in terms of height to maximize the productivity of a single cutting sequence. A haulage speed of up to 6 m/min (19.7 ft/min) in combination with a maximum cutting depth of 100 mm (3.9 in) delivers high production rates.

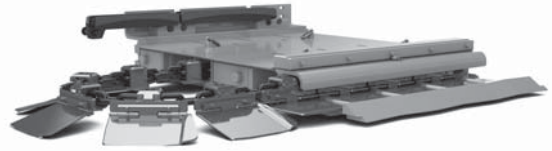

The HRC30 is a newly developed apron face conveyor to suit hard rock applications. Its design is extremely flat, nevertheless sturdy, to transport hard rock in low cutting heights. The conveyor’s modular architecture can be tailored to suit face lengths of up to 100 m (328 ft).

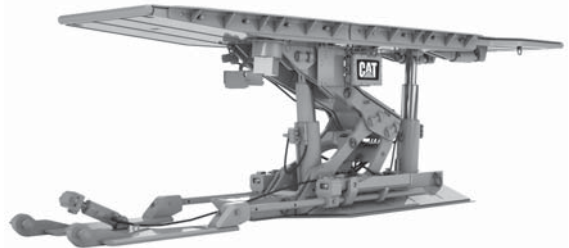

The HRS1220 Hard Rock Roof Support provides customers with state-of-the-art technology to maximize the control of the surrounding rock. They have been specifically engineered to meet the difficult conditions in hard rock mining. Hydraulic cylinders combined with advancing rams guarantee a high level of mechanization.



**Features**

- **Productive** — The Rock Straight System is designed for a continuous cutting operation. The combined use of the hard rock miner (cutting and loading of the material) and the face conveyor (transporting/moving the material) represents a system for simultaneous cutting and hauling — a fast and cost-effective solution generating greater return of investment.
- **Efficient** — The Rock Straight System is tailored to operate in low seam heights — it follows the seam and maximizes the output of cut hard rock material mined out, and leaves waste rock formation above the low seam untouched.
- **Reduces Risks to Health and Safety** — The hydraulically operated hard rock miner and electrically driven hard rock conveyor significantly improve the underground climate and system carbon footprint.
- **Automated** — The fully automated continuous cutting, loading and hauling operation optimizes the process flow and makes hard rock cutting more efficient by shortening the excavation cycle.
- **Safe in Operation** — Cutting of hard and highly abrasive rock reduces or eliminates the need for explosives where it is used. Furthermore, a remote control operation provides optimum comfort and safety for operators, as the operator is placed in a RSPS (FOPS equivalent) certified cabin with air conditioning. This makes job conditions more attractive and lowers operating cost because fewer personnel is needed underground.
- **Service and Maintenance Friendly** — The modular architecture and the compactness of its components support a trouble-free handling. This results in shortened downtimes for repair, maintenance and panel moves.

Hard Rock Miner HRM220

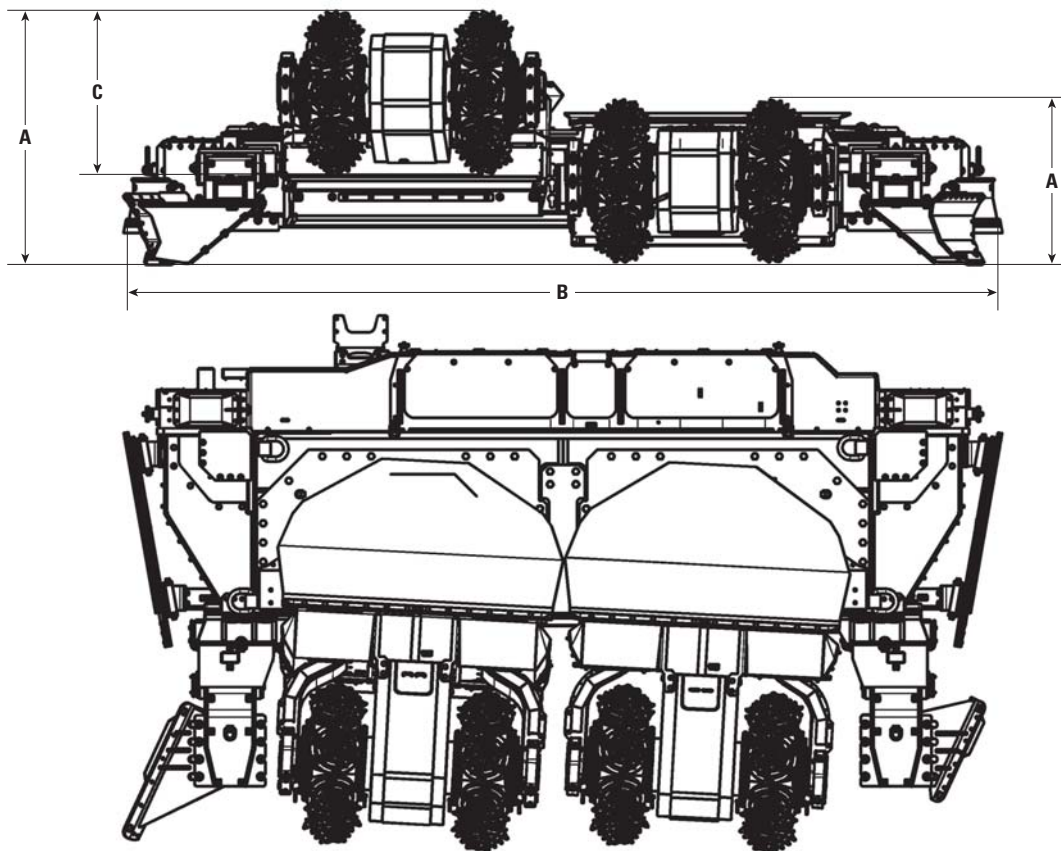

<b>A</b> Seam Range	1.3 m-2.0 m	4.2'-6.6'
<b>B</b> Typical Machine Length	6.8 m	22'4"
<b>C</b> Cutting Head Diameter	1270 mm	50"
Installed Power Hydraulic System	55 kW	73.3 hp
Cutting Units		2
Installed Power per Cutting Unit	132 kW	177 hp
Installed Power Electrical System	319 kW	427.6 hp
Cutting Depth (up to)	100 mm	3.9"
Cutting Drum Speed		60 RPM
Body Height	1200 mm	47.2"
Machine Weight (approximate)	41 tonnes	45.2 tons
Operating Voltage	1000V; 50 Hz; 3 AC	

## Hard Rock

## Rock Straight System Specifications

- Hard Rock Conveyor HRC30

### Hard Rock Conveyor HRC30

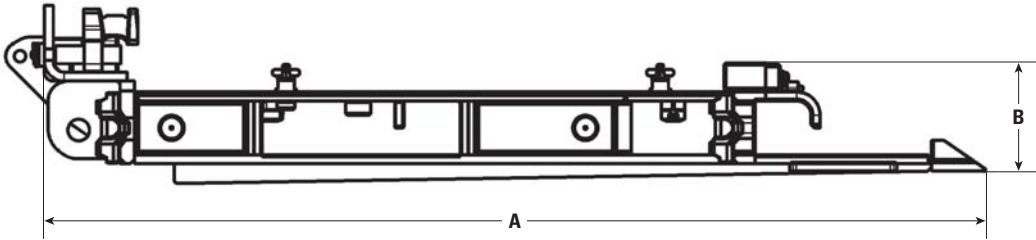

<b>A</b> Line Pan Width	2615 mm	<b>102.95"</b>
<b>B</b> Line Pan Height	280 mm	<b>11.02"</b>
Line Pan Length	1756 mm	<b>69.13"</b>
Chain Length (approximate)	100 m	<b>328'</b>
Conveyor Speed	0.7 m/sec	<b>2.3 ft/min</b>
Line Pan Length	1756 mm	<b>69.13"</b>
Apron Plate Spacing	4 mm x 108 mm	<b>4" x 4.25"</b>
Apron Plate Chain Diameter	30 mm x 108 mm	<b>1.18" x 4.25"</b>
Chain Speed	0.7 m/sec	<b>2.3 ft/min</b>
Capacity per Hour	160 tonnes	<b>176 tons</b>

● Hard Rock Roof Support HRS1220

Hard Rock Roof Support HRS1220

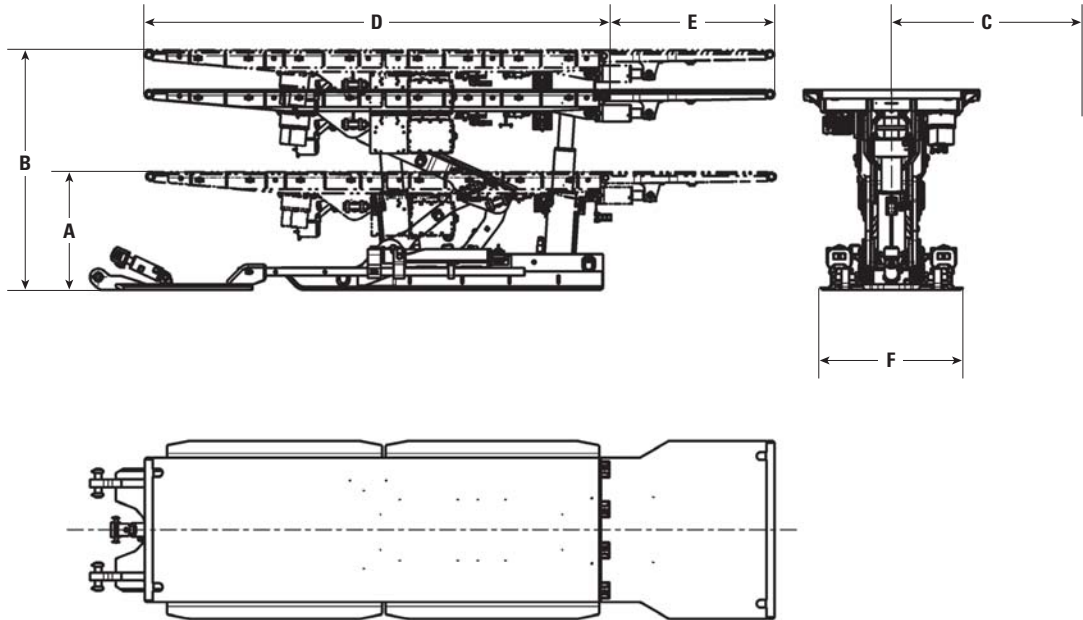

<b>A</b> Height Closed	1060 mm	41.73"
<b>B</b> Height Extended	2150 mm	84.64"
<b>C</b> Canopy Width (includes side seals)	1750 mm	68.90"
<b>D</b> Main Canopy Length	4240 mm	166.93"
<b>E</b> Swivel Canopy Length	1500 mm	59.05"
<b>F</b> Base Width	1300 mm	51.18"
DA Ram Stroke	625 mm	24.60"
Leg Centers Distance (vertical to face)	1440/1660 mm	56.69"/65.35"
Bearing Surface Base	35 360 cm <sup>2</sup>	38.061 ft <sup>2</sup>
Distance Roof Support Centers	1750 mm	68.90"
Support Resistance (at height 1600 mm/62.99")		
Setting Load at 320 bar ( <b>4641 psi</b> )	2209 kN	320.38 psi
Yield Load at 415 bar ( <b>6019 psi</b> )	2599 kN	376.95 psi
Load at the End of Swivel Canopy	100 kN	14.50 psi
Weight	9.3 tonnes	10.25 tons



# LONGWALL

## Roof Supports

### AFC Systems

### Beam Stage Loaders (BSL)

### CST Drive Systems

### Variable Frequency Drives

### Shearers

### Automated Plow Systems

### Programmable Mining Controls

### Roof Support Carriers

### Shield Trailers

**CONTENTS**

**LONGWALL**

Introduction . . . . . 20-32

Roof Supports:

    Features . . . . . 20-32

    Specifications . . . . . 20-33

    Special Applications . . . . . 20-34

AFC Systems:

    Features . . . . . 20-35

    Specifications . . . . . 20-36

    Dimensions . . . . . 20-40

    Conveying Performance . . . . . 20-45

Beam Stage Loaders (BSL):

    Features . . . . . 20-48

    Specifications . . . . . 20-48

CST Drive Systems:

    Features . . . . . 20-51

    Specifications . . . . . 20-52

    Rated Power P/Gearbox Ratio i [-] . . . . . 20-58

Variable Frequency Drives (VFD):

    Features . . . . . 20-60

    Specifications . . . . . 20-61

    Dimensions . . . . . 20-62

Shearers:

    Features . . . . . 20-63

    Specifications . . . . . 20-64

    Dimensions . . . . . 20-71

    Optional Accessories . . . . . 20-81

Automated Plow Systems:

    Features . . . . . 20-82

    Specifications . . . . . 20-83

    Dimensions . . . . . 20-85

Programmable Mining Controls:

    PMC-R:

        Features . . . . . 20-103

        Specifications . . . . . 20-103

    PMC-D and PMC-V:

        Features . . . . . 20-107

        Specifications . . . . . 20-107

    MCU2:

        Features . . . . . 20-111

        Specifications . . . . . 20-111

Roof Support Carriers:

    Features . . . . . 20-113

    Specifications . . . . . 20-114

    Dimensions . . . . . 20-116

    Tractive Effort vs. Speed — Loaded . . . . . 20-118

    % Grade vs. Speed — Loaded . . . . . 20-119

    Lift Capability . . . . . 20-120

Shield Trailers:

    Features . . . . . 20-121

    Specifications . . . . . 20-122

    Dimensions . . . . . 20-123

    SH150 Load Setting Table . . . . . 20-124

## INTRODUCTION

Caterpillar is the global market leader and supplier of complete longwall systems. All over the world, our equipment and systems are meeting the demands of underground mining under the most stringent conditions. Adapted to the mining challenges faced by our customers today, Cat customized systems range from hydraulic roof supports, automated plow systems, shearers, face conveyors and drive systems to automation and roof support carriers. Caterpillar delivers your system of choice, from low to high seam heights, for the longest longwalls and highest production demands.

## ROOF SUPPORTS

### Features



### Equipment You Can Rely On

- Availability typically 98% on average.
- Extensive tests on all structural, hydraulic and control components.
- Sophisticated PMC-R electro-hydraulic controls for full face automation.
- Down to 4-second advance cycles thanks to powerful hydraulics.
- Shield design in 3D, FEM integrated.

### Customized Design

- Seamless range for mining heights from 0.55 to 7.5 m (1.8 to 24.6 ft) with support capacities of up to 1750 metric tonnes (1929 tons).
- Advanced design of critical parts prevents major failures, costly underground repairs and unscheduled downtime.
- Easy maintenance, long intervals between overhaul and very long service life.

**Cat Roof Supports**

Height Closed	500-2900 mm	19.7-114.2"
Height Extended	1100-6100 mm	43.3-240.2"
Shield Centers	1500-2050 mm	59-80.7"
Nominal Leg Forces	2 x 800-2 x 7156 kN	2 x 90-2 x 805 ton
Shield Density	Up to 111 tonne/m <sup>2</sup>	Up to 12.5 ton/ft <sup>2</sup>
Hydraulic Leg	Up to 500 mm	Up to 19.7"
Canopy	<b>Rigid design (with telescopic flipper)</b>	
Canopy Length	2997-8000 mm	118-315"
Forepole Length	1980-4520 mm	78-178"
Rear Projection	850-1448 mm	33.5-57"
Base	<b>Split design OR rigid design with telescopic relay bar/pusher cylinder</b>	
Relay Bar		
Direct Mounted OR Reverse Mounted	650-1067 mm effective web	25.6-39.4" effective web
Shifting Cylinder (with Reedrod)	700-1080 mm	27.6-42.5"
Shield Pull Force	185-565 kN/ 315/320/350 bar	20.7-63.3 ton/ 4568/4640/5076 psi
Conveyor Push Force	89-815 kN/ 315/320/350 bar	10.0-91.5 ton/ 4568/4640/5076 psi
Side Seals-on Canopy, Caving Shield (and rear lemniscates):		
Both Sides Fixed/One Side Fixed, One Side Movable, Rehandable/Not Rehandable	Up to 300 mm stroke	Up to 11.8" stroke
Materials	<b>High strength steel</b>	
Test	<b>EN 1804, different test program with up to 90,000 cycles</b>	
Weight	6.5-63.5 tonne	7.15-70 ton

**Roof Support Specifications**

**Example High Seam Roof Support**

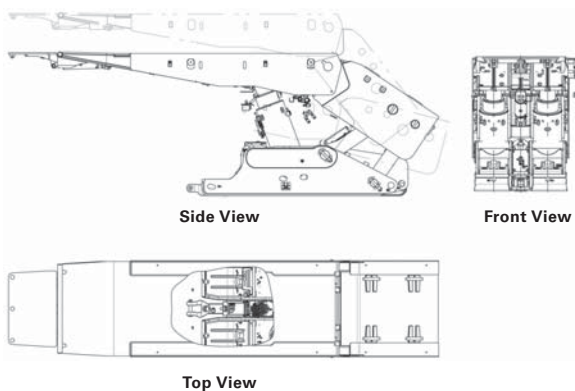

**Example Low Seam Roof Support**

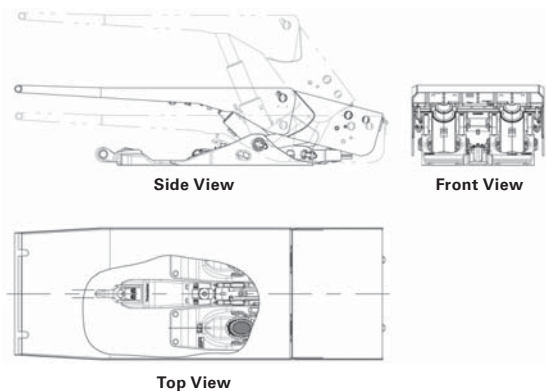



**Special Applications**

Specifically designed roof supports are available for the following mining applications:

- Steep-seam Mining

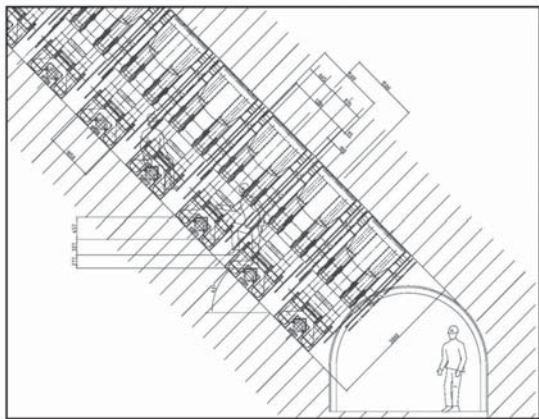

- Conventional Sublevel Caving

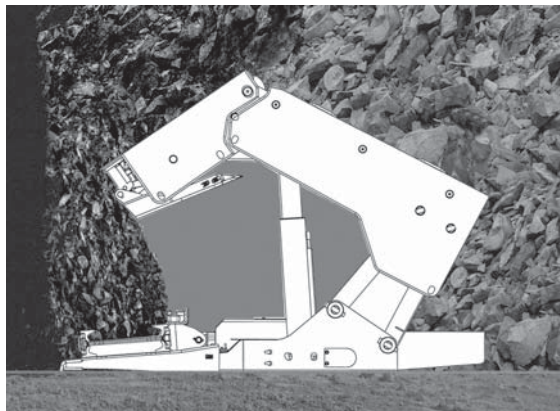

- Longwall Top Coal Caving (LTCC)

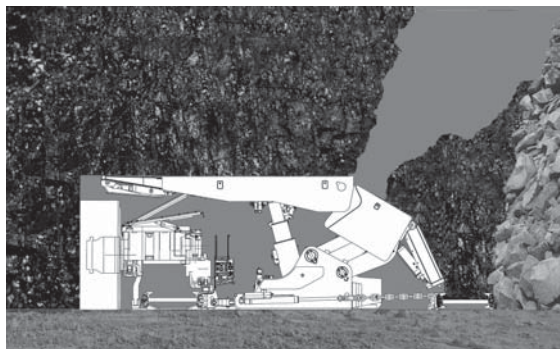

## AFC SYSTEMS

### Features



### Moving Mountains

- For use in longwalls of up to 500 m (1640 ft) long.
- Up to  $3 \times 1800$  kW ( $3 \times 2413$  hp) installed power.
- Capacities of up to 6200 tonnes/hr (6834 tons/hr).
- Intelligent CST drive system available.
- High system availability, long service life, low operating costs.
- Various shearer haulage systems with rack bar or chain.
- Main drive: Cross-frame, side discharge, overhead discharge.
- Rigid or automated tensionable tail drive.

**AFC Line Pan Specifications – PF3**

Model	PF3/722		PF3/822		PF3/922	
Line Pan Width	722 mm	<b>28.42"</b>	822 mm	<b>32.36"</b>	922 mm	<b>36.30"</b>
Flightbar Width	582 mm	<b>22.91"</b>	682 mm	<b>26.85"</b>	782 mm	<b>30.78"</b>
Deck Plate Thickness	30 mm	<b>1.18"</b>	30 mm	<b>1.18"</b>	30 mm	<b>1.18"</b>
Profile Height	244 mm	<b>9.60"</b>	244 mm	<b>9.60"</b>	244 mm	<b>9.60"</b>
Bottom Plate Thickness	20 mm	<b>0.78"</b>	20 mm	<b>0.78"</b>	20 mm	<b>0.78"</b>
Dogbone Breaking Strength	2000 kN	<b>224.80 tonf</b>	2000 kN	<b>224.80 tonf</b>	2000 kN	<b>224.80 tonf</b>
Dogbone Housing FoS	<b>1.5 times</b>		<b>1.5 times</b>		<b>1.5 times</b>	
Shear Strength	3000 kN	<b>337.21 tonf</b>	3000 kN	<b>337.21 tonf</b>	3000 kN	<b>337.21 tonf</b>
Vertical Articulation	<b>Up to ± 6°</b>		<b>Up to ± 6°</b>		<b>Up to ± 6°</b>	
Horizontal Articulation	<b>0.8°-1.2°</b>		<b>0.8°-1.2°</b>		<b>0.8°-1.2°</b>	
Chain Strands	<b>DKB 26×29 DKB 30×108 DKB 34×126 DKB 38×137</b>		<b>DKB 26×29 DKB 30×108 DKB 34×126 DKB 38×137</b>		<b>DKB 26×29 DKB 30×108 DKB 34×126 DKB 38×137</b>	
Conveying Capacity	0.18 m <sup>2</sup>	<b>1.93 ft<sup>2</sup></b>	0.26 m <sup>2</sup>	<b>2.80 ft<sup>2</sup></b>	0.36 m <sup>2</sup>	<b>3.87 ft<sup>2</sup></b>

**AFC Line Pan Specifications – PF4**

Model	PF4/832		PF4/932		PF4/1032	
Line Pan Width	832 mm	<b>52.44"</b>	932 mm	<b>36.69"</b>	1032 mm	<b>40.62"</b>
Flightbar Width	688 mm	<b>46.77"</b>	788 mm	<b>31.02"</b>	888 mm	<b>34.96"</b>
Deck Plate Thickness	40 mm	<b>1.57"</b>	40 mm	<b>1.57"</b>	40 mm	<b>1.57"</b>
Profile Height	284 mm	<b>11.18"</b>	284 mm	<b>11.18"</b>	284 mm	<b>11.18"</b>
Bottom Plate Thickness	25 mm	<b>0.98"</b>	25 mm	<b>0.98"</b>	25 mm	<b>0.98"</b>
Dogbone Breaking Strength	3000- 3600 kN	<b>337.21- 404.65 tonf</b>	3000- 3600 kN	<b>337.21- 404.65 tonf</b>	3000- 3600 kN	<b>337.21- 404.65 tonf</b>
Dogbone Housing FoS	<b>1.5 times</b>		<b>1.5 times</b>		<b>1.5 times</b>	
Shear Strength	4000 kN	<b>449.61 tonf</b>	4000 kN	<b>449.61 tonf</b>	4000 kN	<b>449.61 tonf</b>
Vertical Articulation	<b>Up to ± 6°</b>		<b>Up to ± 6°</b>		<b>Up to ± 6°</b>	
Horizontal Articulation	<b>0.8°-1.2°</b>		<b>0.8°-1.2°</b>		<b>0.8°-1.2°</b>	
Chain Strands	<b>AKB FI30×108 DKB 34×126</b>		<b>AKB FI30×108 DKB 34×126</b>		<b>AKB FI30×108 DKB 34×126 DKB 42×146</b>	
Conveying Capacity	0.26 m <sup>2</sup>	<b>2.80 ft<sup>2</sup></b>	0.36 m <sup>2</sup>	<b>3.87 ft<sup>2</sup></b>	0.46 m <sup>2</sup>	<b>4.95 ft<sup>2</sup></b>

**AFC Line Pan Specifications – PF4 (continued)**

<b>Model</b>	<b>PF4/1132</b>		<b>PF4/1332</b>	
Line Pan Width	1132 mm	<b>44.65"</b>	1332 mm	<b>52.44"</b>
Flightbar Width	988 mm	<b>38.89"</b>	1188 mm	<b>46.77"</b>
Deck Plate Thickness	40 mm	<b>1.57"</b>	40 mm	<b>1.57"</b>
Profile Height	284 mm	<b>11.18"</b>	284 mm	<b>11.18"</b>
Bottom Plate Thickness	25 mm	<b>0.98"</b>	25 mm	<b>0.98"</b>
Dogbone Breaking Strength	3000-3600 kN	<b>337.21-404.65 tonf</b>	3000-3600 kN	<b>337.21-404.65 tonf</b>
Dogbone Housing FoS	<b>1.5 times</b>		<b>1.5 times</b>	
Shear Strength	4000 kN	<b>449.61 tonf</b>	4000 kN	<b>449.61 tonf</b>
Vertical Articulation	<b>Up to ± 6°</b>		<b>Up to ± 6°</b>	
Horizontal Articulation	<b>0.8°-1.2°</b>		<b>0.8°-1.2°</b>	
Chain Strands	<b>DKB 34×126 DKB 42×146 DKB 48×160/144</b>		<b>DKB 42×146 DKB 48×160/144</b>	
Conveying Capacity	0.58 m <sup>2</sup>	<b>6.24 ft<sup>2</sup></b>	0.85 m <sup>2</sup>	<b>9.15 ft<sup>2</sup></b>

**AFC Line Pan Specifications – PF5**

<b>Model</b>	<b>PF5/1142</b>		<b>PF5/1342</b>	
Line Pan Width	1142 mm	<b>44.96"</b>	1342 mm	<b>52.83"</b>
Flightbar Width	988 mm	<b>38.89"</b>	1188 mm	<b>46.77"</b>
Deck Plate Thickness	50 mm	<b>1.96"</b>	50 mm	<b>1.96"</b>
Profile Height	318 mm	<b>12.52"</b>	318 mm	<b>12.52"</b>
Bottom Plate Thickness	30 mm	<b>1.18"</b>	30 mm	<b>1.18"</b>
Dogbone Breaking Strength	4500 kN	<b>505.82 tonf</b>	4500 kN	<b>505.82 tonf</b>
Dogbone Housing FoS	<b>1.5 times</b>		<b>1.5 times</b>	
Shear Strength	> 6000 kN	<b>&gt; 674.42 tonf</b>	> 6000 kN	<b>&gt; 674.42 tonf</b>
Vertical Articulation	<b>Up to ± 6°</b>		<b>Up to ± 6°</b>	
Horizontal Articulation	<b>0.8°-1.2°</b>		<b>0.8°-1.2°</b>	
Chain Strands	<b>DKB 42×146 DKB 48×160/144</b>		<b>DKB 42×146 DKB 48×160/144</b>	
Conveying Capacity	0.58 m <sup>2</sup>	<b>6.24 ft<sup>2</sup></b>	0.85 m <sup>2</sup>	<b>9.15 ft<sup>2</sup></b>

**AFC Line Pan Specifications – PF6**

<b>Model</b>	<b>PF6/1042</b>		<b>PF6/1142</b>	
Line Pan Width	1042 mm	<b>41.02"</b>	1142 mm	<b>44.96"</b>
Flightbar Width	888 mm	<b>34.96"</b>	988 mm	<b>38.89"</b>
Deck Plate Thickness	30 mm plus 25 mm	<b>1.18" plus 0.98"</b>	30 mm plus 25 mm	<b>1.18" plus 0.98"</b>
Profile Height	350 mm	<b>13.77"</b>	350 mm	<b>13.77"</b>
Bottom Plate Thickness	30 mm	<b>1.18"</b>	30 mm	<b>1.18"</b>
Dogbone Breaking Strength	4500 kN	<b>505.82 tonf</b>	4500 kN	<b>505.82 tonf</b>
Dogbone Housing FoS	<b>1.5 times</b>		<b>1.5 times</b>	
Shear Strength	> 6000 kN	<b>&gt; 674.42 tonf</b>	> 6000 kN	<b>&gt; 674.42 tonf</b>
Vertical Articulation	<b>Up to ± 6°</b>		<b>Up to ± 6°</b>	
Horizontal Articulation	<b>0.8°-1.2°</b>		<b>0.8°-1.2°</b>	
Chain Strands	<b>DKB 42×146 DKB 48×160/144</b>		<b>DKB 42×146 DKB 48×160/144</b>	
Conveying Capacity	approx. 0.58 m <sup>2</sup>	<b>approx. 6.24 ft<sup>2</sup></b>	approx. 0.58 m <sup>2</sup>	<b>approx. 6.24 ft<sup>2</sup></b>

<b>Model</b>	<b>PF6/1242</b>		<b>PF6/1342</b>	
Line Pan Width	1242 mm	<b>48.90"</b>	1342 mm	<b>52.83"</b>
Flightbar Width	1088 mm	<b>42.83"</b>	1188 mm	<b>46.77"</b>
Deck Plate Thickness	30 mm plus 25 mm	<b>1.18" plus 0.98"</b>	30 mm plus 25 mm	<b>1.18" plus 0.98"</b>
Profile Height	350 mm	<b>13.77"</b>	350 mm	<b>13.77"</b>
Bottom Plate Thickness	30 mm	<b>1.18"</b>	30 mm	<b>1.18"</b>
Dogbone Breaking Strength	4500 kN	<b>505.82 tonf</b>	4500 kN	<b>505.82 tonf</b>
Dogbone Housing FoS	<b>1.5 times</b>		<b>1.5 times</b>	
Shear Strength	> 6000 kN	<b>&gt; 674.42 tonf</b>	> 6000 kN	<b>&gt; 674.42 tonf</b>
Vertical Articulation	<b>Up to ± 6°</b>		<b>Up to ± 6°</b>	
Horizontal Articulation	<b>0.8°-1.2°</b>		<b>0.8°-1.2°</b>	
Chain Strands	<b>DKB 42×146 DKB 48×160/144</b>		<b>DKB 42×146 DKB 48×160/144</b>	
Conveying Capacity	approx. 0.72 m <sup>2</sup>	<b>approx. 7.75 ft<sup>2</sup></b>	approx. 0.85 m <sup>2</sup>	<b>approx. 9.15 ft<sup>2</sup></b>

**AFC Line Pan Specifications – PF7**

<b>Model</b>	<b>PF7/1542</b>		
Line Pan Width	1542 mm		<b>60.71"</b>
Flightbar Width	1388 mm		<b>54.65"</b>
Deck Plate Thickness	30 mm plus 25 mm		<b>1.18" plus 0.98"</b>
Profile Height	350 mm		<b>13.77"</b>
Bottom Plate Thickness	30 mm		<b>1.18"</b>
Dogbone Breaking Strength	4500 kN		<b>505.82 tonf</b>
Dogbone Housing FoS		<b>1.5 times</b>	
Shear Strength	> 6000 kN		<b>&gt; 674.42 tonf</b>
Vertical Articulation		<b>Up to ± 6°</b>	
Horizontal Articulation		<b>0.8°-1.2°</b>	
Chain Strands		<b>DKB 60x135/181</b>	
Conveying Capacity	approx. 1.15 m <sup>2</sup>		<b>approx. 12.38 ft<sup>2</sup></b>

**AFC Line Pan Dimensions – PF3**  
 (All dimensions are approximate.)

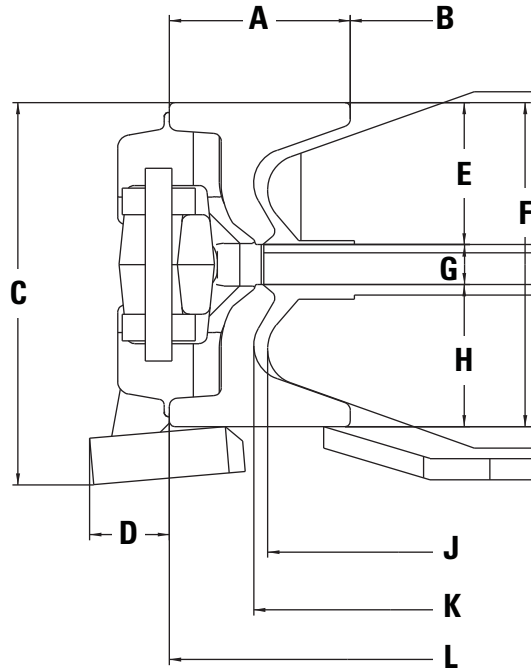

Model	PF3/722		PF3/822		PF3/922	
<b>A</b>	136 mm	<b>5.35"</b>	136 mm	<b>5.35"</b>	136 mm	<b>5.35"</b>
<b>B</b>	450 mm	<b>17.72"</b>	550 mm	<b>21.65"</b>	650 mm	<b>25.59"</b>
<b>C</b>	288 mm	<b>11.33"</b>	288 mm	<b>11.33"</b>	288 mm	<b>11.33"</b>
<b>D</b>	60 mm	<b>2.36"</b>	60 mm	<b>2.36"</b>	60 mm	<b>2.36"</b>
<b>E</b>	107 mm	<b>4.21"</b>	107 mm	<b>4.21"</b>	107 mm	<b>4.21"</b>
<b>F</b>	244 mm	<b>9.6"</b>	244 mm	<b>9.6"</b>	244 mm	<b>9.6"</b>
<b>G</b>	30 mm	<b>1.18"</b>	30 mm	<b>1.18"</b>	30 mm	<b>1.18"</b>
<b>H</b>	107 mm	<b>4.21"</b>	107 mm	<b>4.21"</b>	107 mm	<b>4.21"</b>
<b>J</b>	582 mm	<b>22.91"</b>	682 mm	<b>26.85"</b>	782 mm	<b>30.78"</b>
<b>K</b>	594 mm	<b>23.38"</b>	694 mm	<b>27.32"</b>	794 mm	<b>31.26"</b>
<b>L</b>	722 mm	<b>28.42"</b>	822 mm	<b>32.36"</b>	922 mm	<b>36.30"</b>

**AFC Line Pan Dimensions — PF4**  
(All dimensions are approximate.)

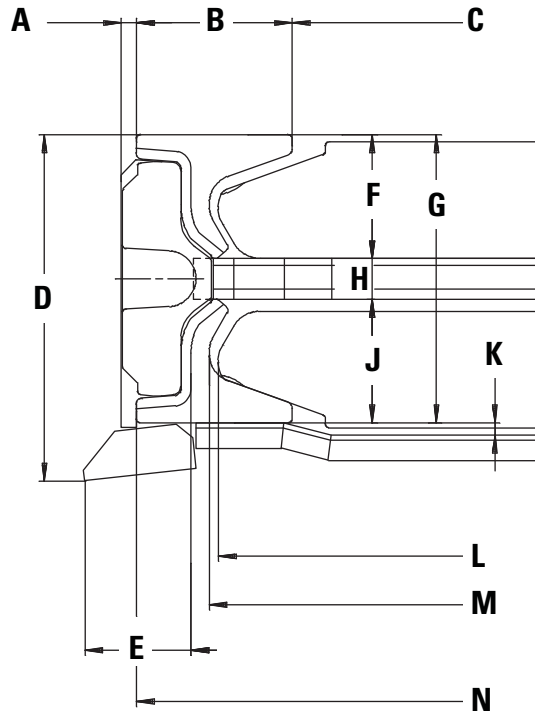

Model	PF4/832		PF4/932		PF4/1032		PF4/1132		PF4/1332	
<b>A</b>	15 mm	0.59"	15 mm	0.59"	15 mm	0.59"	15 mm	0.59"	15 mm	0.59"
<b>B</b>	154 mm	6.06"	154 mm	6.06"	154 mm	6.06"	154 mm	6.06"	154 mm	6.06"
<b>C</b>	524 mm	20.62"	624 mm	24.56"	724 mm	28.50"	824 mm	32.44"	1024 mm	40.31"
<b>D</b>	341 mm	13.42"	341 mm	13.42"	341 mm	13.42"	341 mm	13.42"	341 mm	13.42"
<b>E</b>	105 mm	4.13"	105 mm	4.13"	105 mm	4.13"	105 mm	4.13"	105 mm	4.13"
<b>F</b>	122 mm	4.80"	122 mm	4.80"	122 mm	4.80"	122 mm	4.80"	122 mm	4.80"
<b>G</b>	284 mm	11.18"	284 mm	11.18"	284 mm	11.18"	284 mm	11.18"	284 mm	11.18"
<b>H</b>	40 mm	1.57"	40 mm	1.57"	40 mm	1.57"	40 mm	1.57"	40 mm	1.57"
<b>J</b>	122 mm	4.80"	122 mm	4.80"	122 mm	4.80"	122 mm	4.80"	122 mm	4.80"
<b>K</b>	12 mm	0.47"	12 mm	0.47"	12 mm	0.47"	12 mm	0.47"	12 mm	0.47"
<b>L</b>	676 mm	26.61"	776 mm	30.55"	876 mm	34.48"	976 mm	38.42"	1176 mm	46.29"
<b>M</b>	688 mm	27.08"	788 mm	31.02"	888 mm	34.96"	988 mm	38.89"	1188 mm	46.77"
<b>N</b>	832 mm	32.75"	932 mm	36.69"	1032 mm	40.62"	1132 mm	44.56"	1332 mm	52.44"



**AFC Line Pan Dimensions – PF5**  
 (All dimensions are approximate.)

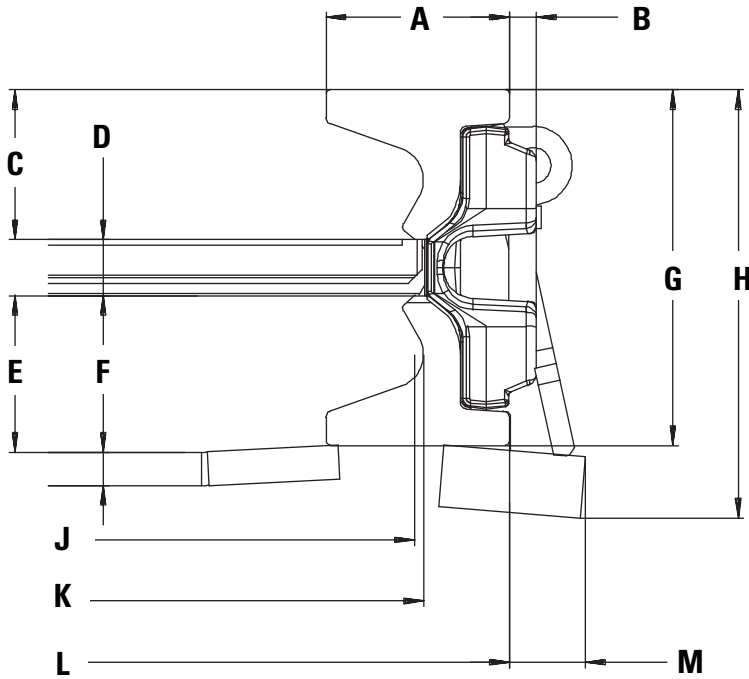

Model	PF5/1142		PF5/1342	
<b>A</b>	164 mm	6.45"	164 mm	6.45"
<b>B</b>	24 mm	0.94"	24 mm	0.94"
<b>C</b>	134 mm	5.27"	134 mm	5.27"
<b>D</b>	50 mm	1.96"	50 mm	1.96"
<b>E</b>	140 mm	5.51"	140 mm	5.51"
<b>F</b>	30 mm	1.18"	30 mm	1.18"
<b>G</b>	318 mm	12.52"	318 mm	12.52"
<b>H</b>	383 mm	15.07"	383 mm	15.07"
<b>J</b>	976 mm	38.42"	1176 mm	46.29"
<b>K</b>	988 mm	38.89"	1188 mm	46.77"
<b>L</b>	1142 mm	44.96"	1342 mm	52.83"
<b>M</b>	68 mm	2.67"	68 mm	2.67"

**AFC Line Pan Dimensions – PF6**  
(All dimensions are approximate.)

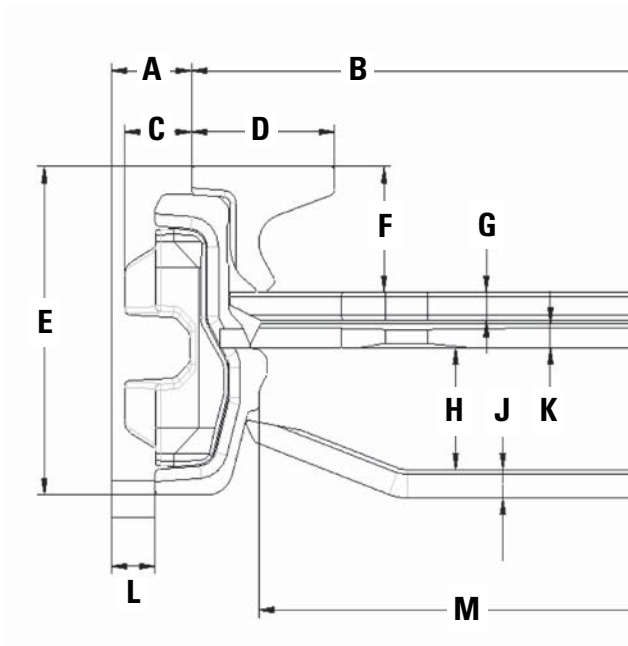

Model	PF6/1042		PF6/1142		PF6/1242		PF6/1342	
<b>A</b>	92 mm	3.62"	92 mm	3.62"	92 mm	3.62"	92 mm	3.62"
<b>B</b>	1042 mm	41.02"	1142 mm	44.96"	1242 mm	48.90"	1342 mm	52.83"
<b>C</b>	77 mm	3.03"	77 mm	3.03"	77 mm	3.03"	77 mm	3.03"
<b>D</b>	164 mm	6.45"	164 mm	6.45"	164 mm	6.45"	164 mm	6.45"
<b>E</b>	350 mm	13.77"	350 mm	13.77"	350 mm	13.77"	350 mm	13.77"
<b>F</b>	134 mm	5.27"	134 mm	5.27"	134 mm	5.27"	134 mm	5.27"
<b>G</b>	30 mm	1.18"	30 mm	1.18"	30 mm	1.18"	30 mm	1.18"
<b>H</b>	130 mm	5.11"	130 mm	5.11"	130 mm	5.11"	130 mm	5.11"
<b>J</b>	30 mm	1.18"	30 mm	1.18"	30 mm	1.18"	30 mm	1.18"
<b>K</b>	25 mm	0.98"	25 mm	0.98"	25 mm	0.98"	25 mm	0.98"
<b>L</b>	50 mm	1.96"	50 mm	1.96"	50 mm	1.96"	50 mm	1.96"
<b>M</b>	888 mm	34.96"	988 mm	38.89"	1088 mm	42.83"	1188 mm	46.77"

**AFC Line Pan Dimensions – PF7**  
 (All dimensions are approximate.)

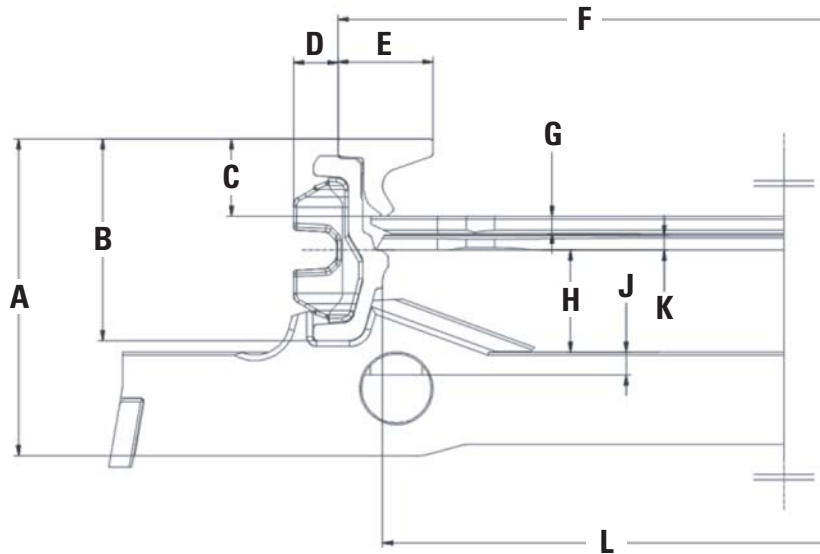

Model	PF7/1542	
A	550 mm	21.6"
B	350 mm	13.78"
C	134 mm	5.27"
D	77 mm	3.03"
E	164 mm	6.46"
F	1542 mm	60.71"
G	30 mm	1.18"
H	177 mm	6.97"
J	40 mm	1.57"
K	25 mm	0.98"
L	1388 mm	54.65"

**AFC Line Pan Conveying Performance — PF3**

**PF3/722**

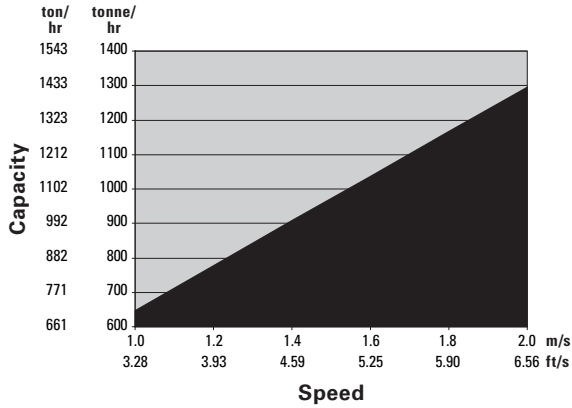

**AFC Line Pan Conveying Performance — PF4**

**PF4/832**

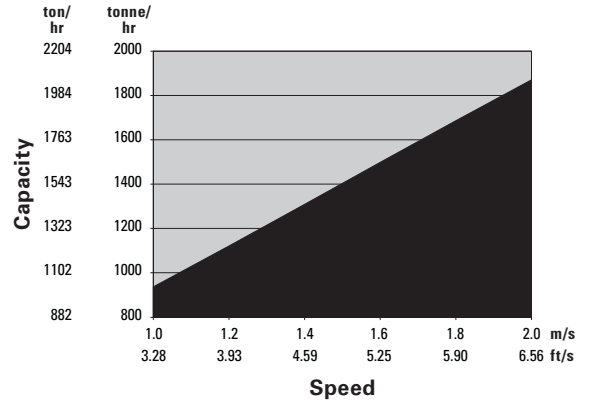

**PF3/822**

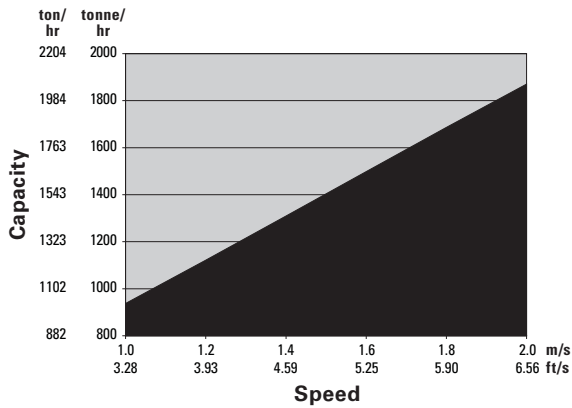

**PF4/932**

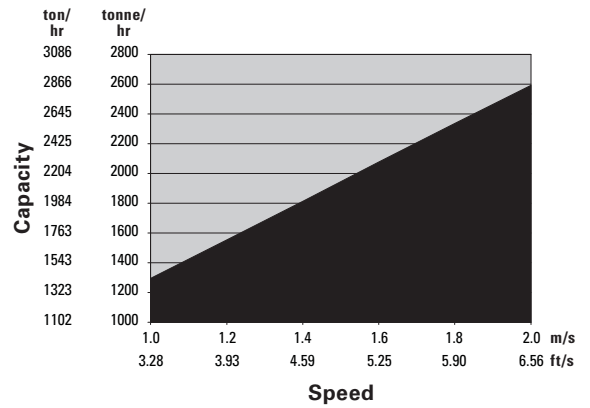

**PF3/922**

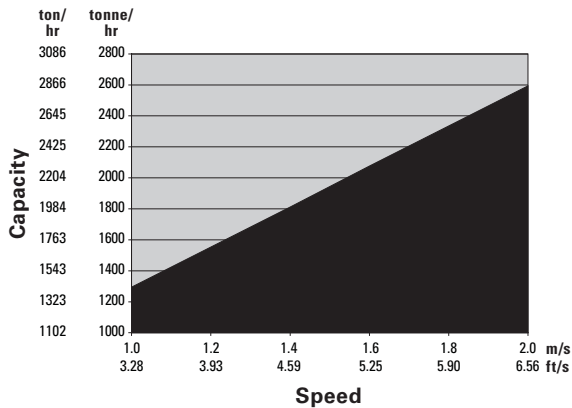

**PF4/1032**

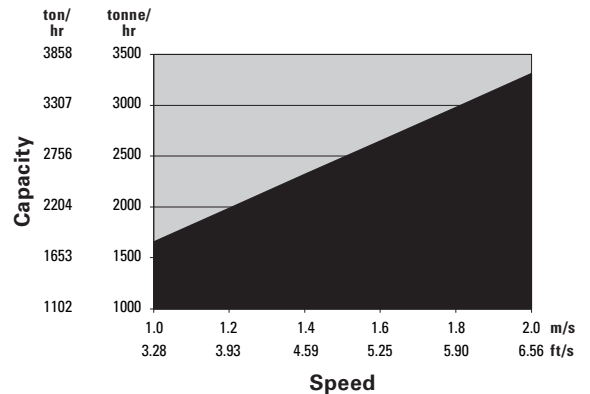

**AFC Line Pan Conveying Performance — PF4**

**PF4/1132**

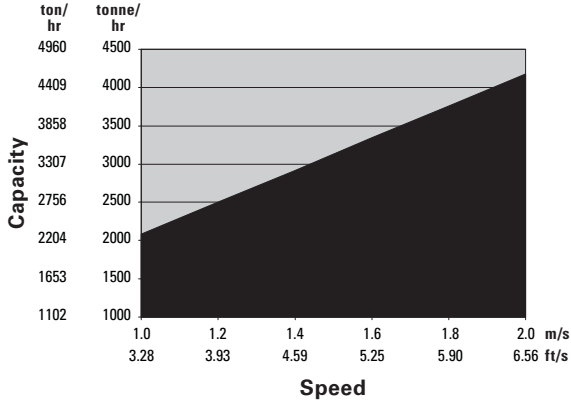

**AFC Line Pan Conveying Performance — PF5**

**PF5/1142**

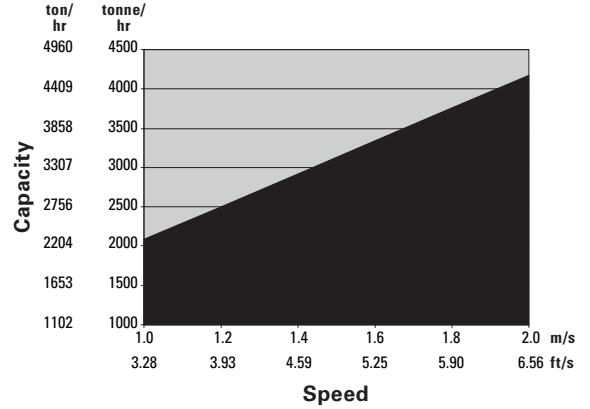

**PF4/1332**

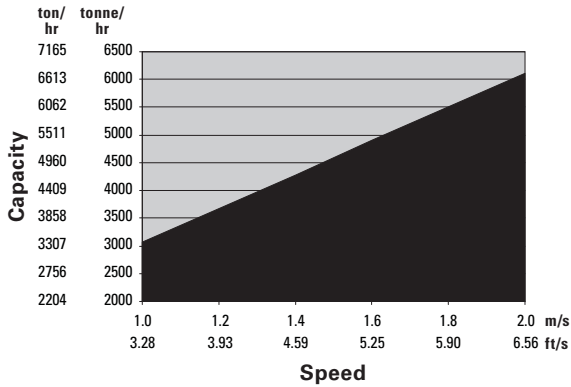

**PF5/1342**

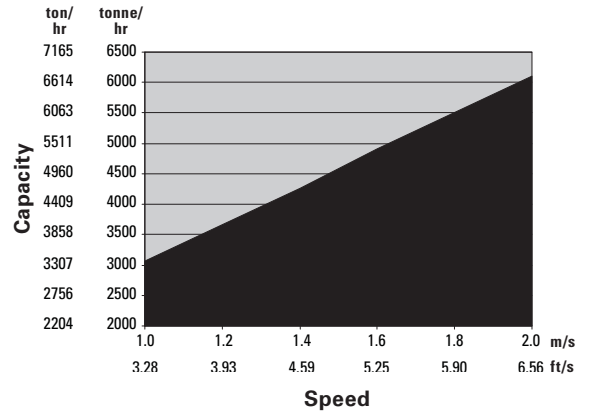

**AFC Line Pan Conveying Performance — PF6**

**PF6/1042**

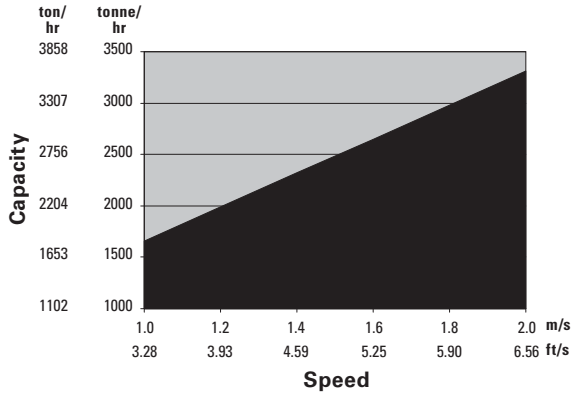

**AFC Line Pan Conveying Performance — PF6**

**PF6/1342**

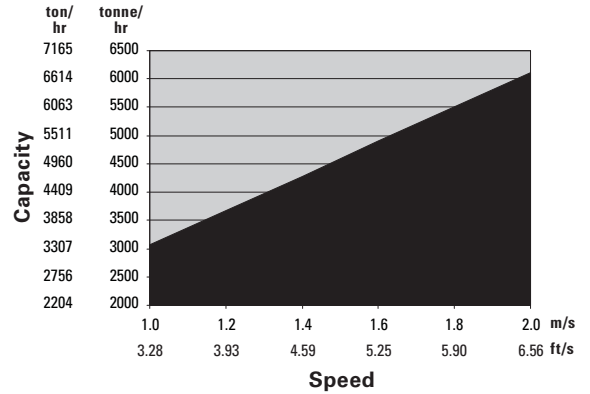

**PF6/1142**

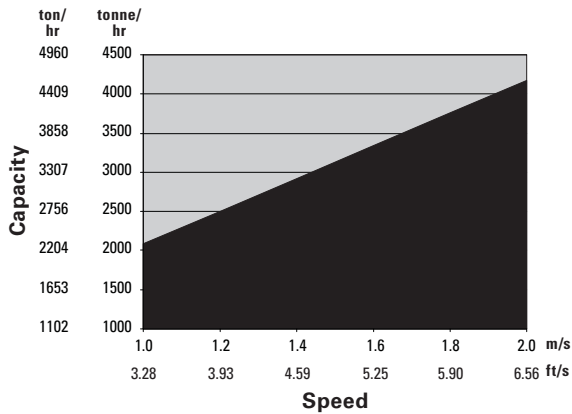

**AFC Line Pan Conveying Performance — PF7**

**PF7/1542**

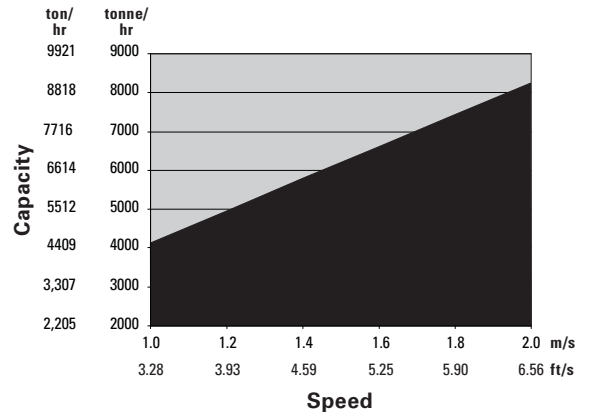

**PF6/1242**

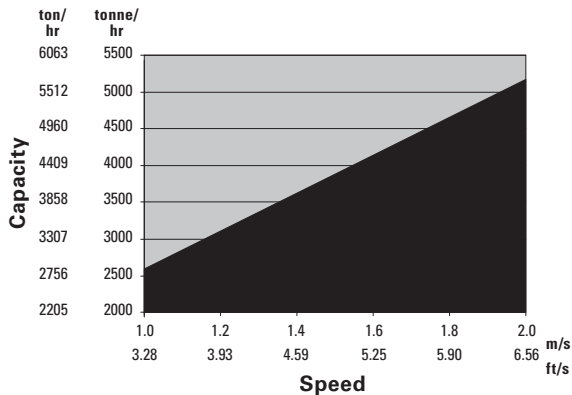

- Features
- Specifications

**BEAM STAGE LOADERS (BSL)**



The AFC is continuously running and conveys the coal mined by a shearer or plow to the head gate, where it is transferred onto the beam stage loader (BSL) with integrated crusher and then onto the main belt (eventually to the surface).

**Main Functions of a BSL:**

- Transportation of the coal from the AFC and hand-over to the belt conveyor.
- Crushing of coal blocks to smaller sizes to suit belt capability.

**Features**

- Stageloader and crusher completely matched to AFC, both with higher capacity to prevent bottlenecks.
- Tailor-made belt tailpiece for required capacity and belt dimensions, allowing BTP to handle longitudinal and lateral entry gradients.
- Horizontal crusher for high throughput and low operating costs due to double action impact elements.
- Automated chain tensioning system for enhanced chain and sprocket lifetime. As option SlackTronic available for superior chain tension management.
- Patented PowerChain technology available.

**BSL Line Pan Specifications**

Model	PF4		PF5		PF6	
Width Outside	932 mm	<b>36.69"</b>	1342 mm	<b>52.83"</b>	1342 mm	<b>52.83"</b>
	1132 mm	<b>44.56"</b>	1542 mm	<b>60.71"</b>	1542 mm	<b>60.71"</b>
	1332 mm	<b>52.44"</b>	1742 mm	<b>68.58"</b>	1742 mm	<b>68.58"</b>
Typical Top Plate Thickness	40 mm	<b>1.57"</b>	50 mm	<b>1.97"</b>	30 mm	<b>1.18"</b>
					(+ 25 mm)	<b>(+ 0.98")</b>
Bottom Plate Thickness	25 mm	<b>0.98"</b>	30 mm	<b>1.18"</b>	30 mm	<b>1.18"</b>
Dogbone Breaking Force	3600 kN	<b>809,312 lbf</b>	4500 kN	<b>1,011,640 lbf</b>	4500 kN	<b>1,011,640 lbf</b>
Production Average per Year	2000 tonnes	<b>2204 tons</b>	5500 tonnes	<b>6063 tons</b>	5500 tonnes	<b>6063 tons</b>
	3800 tonnes	<b>4189 tons</b>	6200 tonnes	<b>6834 tons</b>	6200 tonnes	<b>6834 tons</b>
	5500 tonnes	<b>6063 tons</b>	7000 tonnes	<b>7716 tons</b>	7000 tonnes	<b>7716 tons</b>

**BSL Crusher — Impact Roll Crusher Specifications**

Model	SK0909		SK1111		SK1118	
Feed Size	875 × 500 × X mm	<b>34.4 × 19.7 × X"</b>	1050 × 600 × X mm	<b>41.3 × 23.6 × X"</b>	1750 × 600 × X mm	<b>68.9 × 23.6 × X"</b>
Roll Diameter	910 mm	<b>35.83"</b>	1100 mm	<b>43.31"</b>	1100 mm	<b>43.31"</b>
Inlet Width	925 mm	<b>36.42"</b>	1100 mm	<b>43.31"</b>	1800 mm	<b>70.87"</b>
Maximum Passage Height	295 mm	<b>11.61"</b>	300 mm	<b>11.81"</b>	300 mm	<b>11.81"</b>
Type of Drive	<b>Gearbox or V-Belt</b>		<b>Gearbox or V-Belt</b>		<b>Gearbox or V-Belt</b>	
Maximum Installed Power V-Belt	132 kW	<b>177 hp</b>	315 kW	<b>422 hp</b>	500 kW	<b>671 hp</b>
Maximum Installed Power Gearbox	2 × 90 kW	<b>2 × 121 hp</b>	400 kW	<b>536 hp</b>	400 kW	<b>536 hp</b>
Throughput	1500 tonnes/hr	<b>1653 tons/hr</b>	3000 tonnes/hr	<b>3307 tons/hr</b>	5000 tonnes/hr	<b>5511 tons/hr</b>

Model	SK1218		SK1422	
Feed Size	1750 × 650 × X mm	<b>68.9 × 25.6 × X"</b>	2150 × 750 × X mm	<b>84.6 × 29.5 × X"</b>
Roll Diameter	1200 mm	<b>47.24"</b>	1400 mm	<b>55.12"</b>
Inlet Width	1800 mm	<b>70.87"</b>	2200 mm	<b>86.61"</b>
Maximum Passage Height	300 mm	<b>11.81"</b>	300 mm	<b>11.81"</b>
Type of Drive	<b>Gearbox or V-Belt</b>		<b>Gearbox or V-Belt</b>	
Maximum Installed Power V-Belt	750 kW	<b>1006 hp</b>	750 kW	<b>1006 hp</b>
Maximum Installed Power Gearbox	750 kW	<b>1006 hp</b>	750 kW	<b>1006 hp</b>
Throughput	6000 tonnes/hr	<b>6614 tons/hr</b>	8000 tonnes/hr	<b>8818 tons/hr</b>

**Features**

- Horizontal crushing.
- Exchangeable impact elements as standard.
- Hydraulic height adjustment of crusher roll to match output size to belt capability.
- PMC monitored overload protection causing BSL speed variation down to automatic stop.
- Spraying integrated into impact roll or spraying from the top cover for dust suppression available.
- Central lubrication system.

**Tensionable Drive Frame Specifications**

Model	SPR3		SPR5	
Available Widths	900 mm	<b>35.43"</b>	1100 mm	<b>43.31"</b>
	1100 mm	<b>43.31"</b>	1300 mm	<b>51.18"</b>
	1300 mm	<b>51.18"</b>	1500 mm	<b>59.06"</b>
	1500 mm	<b>59.06"</b>	1700 mm	<b>66.93"</b>
Sprocket	<b>Universal Sprocket</b>		<b>Universal Sprocket</b>	
Installed Power	Up to 400 kW	<b>Up to 536 hp</b>	Up to 500 kW	<b>Up to 671 hp</b>
Stroke	350 mm	<b>13.78"</b>	500 mm	<b>19.68"</b>
Capacity	Up to 6200 tonnes/hr	<b>Up to 6834 tons/hr</b>	Up to 7000 tonnes/hr	<b>Up to 7716 tons/hr</b>



**BSL Gearbox Specifications**

Model	K-10		KP-25/30	
Maximum Output Torque for Short Duration (3 sec.)	100 000 N·m	<b>73,756 lb-ft</b>	300 000 N·m	<b>221,269 lb-ft</b>
Maximum Input Speed (Motor Speed)	<b>1800 RPM</b>		<b>1800 RPM</b>	
Maximum Installed Power at:				
i = 39:1	160 kW*	<b>262 hp**</b>	435 kW*	<b>709 hp**</b>
i = 33:1	x	<b>x</b>	500 kW*	<b>816 hp**</b>
i = 28:1	200 kW*	<b>326 hp**</b>	500 kW*	<b>816 hp**</b>
i = 24,4:1	200 kW*	<b>326 hp**</b>	500 kW*	<b>816 hp**</b>
i = 21:1	200 kW*	<b>326 hp**</b>	500 kW*	<b>816 hp**</b>
i = 18:1	200 kW*	<b>326 hp**</b>	500 kW*	<b>816 hp**</b>
i = 16,94:1	200 kW*	<b>326 hp**</b>	—	—
i = 16:1	—	—	500 kW*	<b>816 hp**</b>
Input Shaft	<b>D = 90</b>		<b>D=100 or W 100x4</b>	
Output Shaft	<b>W160/N190</b>		<b>N 220x10</b>	
Required Cooling Water Flow	5 L/min	<b>1.32 gal/min</b>	15-20 L/min	<b>3.96-5.28 gal/min</b>
Cooling Water Inlet Temperature	25° C	<b>77° C</b>	25° C	<b>77° C</b>
Oil Filling Quantities	120 L	<b>31 U.S. gal</b>	137 L	<b>36 U.S. gal</b>
Weight (without oil)	1910 kg	<b>4211 lb</b>	3200 kg	<b>7055 lb</b>
Dimensions:				
Height	690 mm	<b>27.16"</b>	820 mm	<b>32.28"</b>
Length	1665 mm	<b>65.55"</b>	1419 mm	<b>55.87"</b>
Width	560 mm	<b>22.05"</b>	943 mm	<b>37.13"</b>

\*Rated Power P [kW] (n = 1.485 RPM) (@ 50 Hz).

\*\*Rated Power P [hp] (n = 1.782 RPM) (@ 60 Hz).

**Boot End Specifications**

Model	Skid-Mounted Boot End (SMB)		Crawler-Mounted Boot End (CMB)	
Belt Width	1000 mm	<b>39.37"</b>	1400 mm	<b>55.12"</b>
	1200 mm	<b>47.24"</b>		
	1400 mm	<b>55.12"</b>		
	1600 mm	<b>62.99"</b>		
Advancing Mechanism:				
Overlap	Up to 3500 mm	<b>Up to 137.80"</b>	Up to 3000 mm	<b>Up to 118.11"</b>
Recommendation	<b>Normal Floor Conditions</b>		<b>Soft Floor</b>	

## CST DRIVE SYSTEMS

### Features

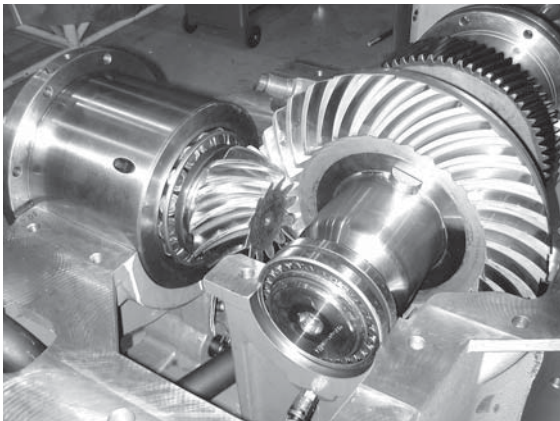

### The Drive for Productivity

- No-load motor start-up with minimized energy demand on the electrical system.
- Soft start of the face conveyors which is gentle to all components, particularly the chain.
- Maximum total torque, available to facilitate heavy load start-up of the fully loaded conveyor.
- Accurate load sharing between the drives for full utilization of the installed power.
- Excellent overload protection in the event of sudden chain jams.
- Clutch delivers maximum efficiency with minimum operational slip of 0.2% with no wear.

**Specifications**

<b>Model</b>	<b>CST30</b>			
Typical Application	<b>Chain Type Longwall Machinery like Armored Face Conveyors (AFC)</b>			
	<b>KP-30 CST</b>		<b>P-30 CST</b>	
Maximum Output Torque (for 3 sec) $T_{max}$ [N·m]	300 000 N·m	<b>221,269 lb-ft</b>	300 000 N·m	<b>221,269 lb-ft</b>
Ratio i [-]:	Rated Power P (n = 1485 RPM)	<b>Rated Power P (n = 1782 RPM)</b>	Rated Power P (n = 1485 RPM)	<b>Rated Power P (n = 1782 RPM)</b>
16	500 kW	<b>816 hp</b>	500 kW	<b>816 hp</b>
21	500 kW	<b>816 hp</b>	500 kW	<b>816 hp</b>
24.4	500 kW	<b>816 hp</b>	500 kW	<b>816 hp</b>
28	500 kW	<b>816 hp</b>	500 kW	<b>816 hp</b>
33	500 kW	<b>816 hp</b>	500 kW	<b>816 hp</b>
39	435 kW	<b>710 hp</b>	435 kW	<b>710 hp</b>
50	400 kW	<b>653 hp</b>	400 kW	<b>653 hp</b>
Dimensions:				
Length	2280 mm	<b>89.8"</b>	1400 mm	<b>55.1"</b>
Width	1180 mm	<b>46.5"</b>	960 mm	<b>37.8"</b>
Height	900 mm	<b>35.4"</b>	900 mm	<b>35.4"</b>
Capacity:				
Oil Quantity	500 L	<b>132 U.S. gal</b>	250 L	<b>66 U.S. gal</b>
Gearbox Weight (without oil)	5800 kg	<b>12,783 lb</b>	3900 kg	<b>8596 lb</b>
Requirements of Cooling Water:				
Required Cooling Water	20 L/min	<b>5.28 gal/min</b>	20 L/min	<b>5.28 gal/min</b>
Maximum Water Inlet Temperature	25° C/298,15 K	<b>77° F/298.15 K</b>	25° C/298,15 K	<b>77° F/298.15 K</b>
Shaft Design:				
Input Shaft (cylindrical)	<b>DIN 5480-W 100×4×30×24</b>		<b>DIN 5480-W 100×4×30×24</b>	
Output Shaft with Internal Toothing	<b>DIN 5480-N 220×10×30×20</b>		<b>DIN 5480-N 220×10×30×20</b>	

**Specifications**

<b>Model</b>	<b>CST45</b>			
Typical Application	<b>Chain Type Longwall Machinery like Armored Face Conveyors (AFC)</b>			
	<b>KP-45 CST</b>		<b>P-45 CST</b>	
Maximum Output Torque (for 3 sec) $T_{max}$ [N·m]	450 000 N·m	<b>331,858 lb-ft</b>	450 000 N·m	<b>331,858 lb-ft</b>
Ratio i [-]:	Rated Power P (n = 1485 RPM)	<b>Rated Power P (n = 1782 RPM)</b>	Rated Power P (n = 1485 RPM)	<b>Rated Power P (n = 1782 RPM)</b>
24.5	800 kW	<b>1305 hp</b>	800 kW	<b>1305 hp</b>
28	800 kW	<b>1305 hp</b>	800 kW	<b>1305 hp</b>
33	800 kW	<b>1305 hp</b>	800 kW	<b>1305 hp</b>
39	700 kW	<b>1142 hp</b>	700 kW	<b>1142 hp</b>
45	540 kW	<b>881 hp</b>	540 kW	<b>881 hp</b>
50	500 kW	<b>816 hp</b>	500 kW	<b>816 hp</b>
Dimensions:				
Length	2875 mm	<b>113.2"</b>	1697 mm	<b>66.8"</b>
Width	1401 mm	<b>55.2"</b>	1120 mm	<b>44.1"</b>
Height	1060 mm	<b>41.7"</b>	1060 mm	<b>41.7"</b>
Capacity:				
Oil Quantity	730 L	<b>193 U.S. gal</b>	430 L	<b>114 U.S. gal</b>
Gearbox Weight (without oil)	9700 kg	<b>21,385 lb</b>	5900 kg	<b>13,007 lb</b>
Requirements of Cooling Water:				
Required Cooling Water	25 L/min	<b>6.6 gal/min</b>	25 L/min	<b>6.6 gal/min</b>
Maximum Water Inlet Temperature	25° C/298,15 K	<b>77° F/298.15 K</b>	25° C/298,15 K	<b>77° F/298.15 K</b>
Shaft Design:				
Input Shaft (cylindrical)	<b>DIN 5480-W 120x4</b>		<b>DIN 5480-W 120x4</b>	
Output Shaft with Internal Tothing	<b>DIN 5480-N 260x10x30x24</b>		<b>DIN 5480-N 260x10x30x24</b>	

**Specifications**

<b>Model</b>	<b>CST45 M</b>	
Typical Application	<b>Chain Type Longwall Machinery like Armored Face Conveyors (AFC) and Plow Systems</b>	
	<b>P-45 M CST</b>	
Maximum Output Torque (for 3 sec) $T_{max}$ [N·m]	450 000 N·m	<b>331,858 lb-ft</b>
Ratio i [-]:	Rated Power P (n = 1485 RPM)	<b>Rated Power P (n = 1782 RPM)</b>
16	800 kW	<b>1305 hp</b>
21	800 kW	<b>1305 hp</b>
28	800 kW	<b>1305 hp</b>
33	800 kW	<b>1305 hp</b>
39	700 kW	<b>1142 hp</b>
45	540 kW	<b>881 hp</b>
50	500 kW	<b>816 hp</b>
Dimensions:		
Length	1697 mm	<b>66.8"</b>
Width	1120 mm	<b>44.1"</b>
Height	1060 mm	<b>41.7"</b>
Capacity:		
Oil Quantity	320 L	<b>85 U.S. gal</b>
Gearbox Weight (without oil)	7200 kg	<b>15,873 lb</b>
Requirements of Cooling Water:		
Required Cooling Water	30 L/min	<b>7.9 gal/min</b>
Maximum Water Inlet Temperature	25° C/298,15 K	<b>77° F/298.15 K</b>
Shaft Design:		
Input Shaft (cylindrical)	<b>DIN 5480-W 120x4</b>	
Output Shaft with Internal Toothing	<b>DIN 5480-N 260x10x30x24</b>	

**Specifications**

<b>Model</b>	<b>CST45 V</b>			
Typical Application	<b>Chain Type Longwall Machinery like Armored Face Conveyors (AFC)</b>			
	<b>KP-45 V CST</b>		<b>P-45 V CST</b>	
Maximum Output Torque (for 3 sec) $T_{max}$ [N·m]	450 000 N·m	<b>331,858 lb-ft</b>	450 000 N·m	<b>331,858 lb-ft</b>
Ratio i [-]:	Rated Power P (n = 1485 RPM)	<b>Rated Power P (n = 1782 RPM)</b>	Rated Power P (n = 1485 RPM)	<b>Rated Power P (n = 1782 RPM)</b>
16	1050 kW	<b>1713 hp</b>	1050 kW	<b>1713 hp</b>
21	1050 kW	<b>1713 hp</b>	1050 kW	<b>1713 hp</b>
28	1050 kW	<b>1713 hp</b>	1050 kW	<b>1713 hp</b>
33	1050 kW	<b>1713 hp</b>	1050 kW	<b>1713 hp</b>
39	820 kW	<b>1338 hp</b>	820 kW	<b>1338 hp</b>
45	710 kW	<b>1158 hp</b>	710 kW	<b>1158 hp</b>
50	650 kW	<b>1061 hp</b>	650 kW	<b>1061 hp</b>
Dimensions:				
Length	2875 mm	<b>113.2"</b>	1697 mm	<b>66.8"</b>
Width	1401 mm	<b>55.2"</b>	1120 mm	<b>44.1"</b>
Height	1060 mm	<b>41.7"</b>	1060 mm	<b>41.7"</b>
Capacity:				
Oil Quantity	730 L	<b>193 U.S. gal</b>	430 L	<b>114 U.S. gal</b>
Gearbox Weight (without oil)	9700 kg	<b>21,380 lb</b>	5900 kg	<b>13,000 lb</b>
Requirements of Cooling Water:				
Required Cooling Water	25 L/min	<b>6.6 gal/min</b>	25 L/min	<b>6.6 gal/min</b>
Maximum Water Inlet Temperature	25° C/298,15 K	<b>77° F/298.15 K</b>	25° C/298,15 K	<b>77° F/298.15 K</b>
Shaft Design:				
Input Shaft (cylindrical)	<b>DIN 5480-W 120×4</b>		<b>DIN 5480-W 120×4</b>	
Output Shaft with Internal Toothings	<b>DIN 5480-N 260×10×30×24</b>		<b>DIN 5480-N 260×10×30×24</b>	

**Specifications**

<b>Model</b>	<b>CST65</b>			
Typical Application	<b>Chain Type Longwall Machinery like Armored Face Conveyors (AFC)</b>			
	<b>KP-65 CST</b>		<b>P-45 CST</b>	
Maximum Output Torque (for 3 sec) $T_{max}$ [N·m]	650 000 N·m	<b>479,415 lb-ft</b>	650 000 N·m	<b>479,415 lb-ft</b>
Ratio i [-]:	Rated Power P (n = 1480 RPM)	<b>Rated Power P (n = 1800 RPM)</b>	Rated Power P (n = 1480 RPM)	<b>Rated Power P (n = 1800 RPM)</b>
28	1200 kW	<b>1958 hp</b>	1200 kW	<b>1958 hp</b>
33	1200 kW	<b>1958 hp</b>	1200 kW	<b>1958 hp</b>
39	1000 kW	<b>1632 hp</b>	1000 kW	<b>1632 hp</b>
45	900 kW	<b>1468 hp</b>	900 kW	<b>1468 hp</b>
50	800 kW	<b>1305 hp</b>	800 kW	<b>1305 hp</b>
Dimensions:				
Length	2910 mm	<b>114.6"</b>	1887 mm	<b>74.3"</b>
Width	1530 mm	<b>60.2"</b>	1120 mm	<b>44.1"</b>
Height	1060 mm	<b>41.7"</b>	1060 mm	<b>41.7"</b>
Capacity:				
Oil Quantity	800 L	<b>211 U.S. gal</b>	500 L	<b>132 U.S. gal</b>
Gearbox Weight (without oil)	10 880 kg	<b>23,980 lb</b>	7300 kg	<b>16,094 lb</b>
Requirements of Cooling Water:				
Required Cooling Water	25 L/min	<b>6.6 gal/min</b>	25 L/min	<b>6.6 gal/min</b>
Maximum Water Inlet Temperature	25° C/298,15 K	<b>77° F/298.15 K</b>	25° C/298,15 K	<b>77° F/298.15 K</b>
Shaft Design:				
Input Shaft (cylindrical)	<b>DIN 5480-W 120×4</b>		<b>DIN 5480-W 120×4</b>	
Output Shaft with Internal Tothing	<b>DIN 5480-N 320×10</b>		<b>DIN 5480-N 320×10</b>	

**Specifications**

<b>Model</b>	<b>CST115</b>			
Typical Application	<b>Chain Type Longwall Machinery like Armored Face Conveyors (AFC)</b>			
	<b>KP-115 CST</b>		<b>P-115 CST</b>	
Maximum Output Torque (for 3 sec) $T_{max}$ [N·m]	1 150 000 N·m	<b>848,196 lb-ft</b>	1 150 000 N·m	<b>848,196 lb-ft</b>
Ratio i [-]:	Rated Power P (n = 1485 RPM)	<b>Rated Power P (n = 1782 RPM)</b>	Rated Power P (n = 1485 RPM)	<b>Rated Power P (n = 1782 RPM)</b>
39	1800 kW	<b>2937 hp</b>	1800 kW	<b>2937 hp</b>
46	1800 kW	<b>2480 hp</b>	1800 kW	<b>2480 hp</b>
Dimensions:				
Length	3600 mm	<b>141.6"</b>	2811 mm	<b>110.6"</b>
Width	2029 mm	<b>79.8"</b>	1400 mm	<b>55.1"</b>
Height	1300 mm	<b>51.1"</b>	1300 mm	<b>51.1"</b>
Capacity:				
Oil Quantity	1300 L	<b>212 U.S. gal</b>	700 L	<b>132 U.S. gal</b>
Gearbox Weight (without oil)	23 980 kg	<b>52,851 lb</b>	16 400 kg	<b>36,145 lb</b>
Requirements of Cooling Water:				
Required Cooling Water	90 L/min	<b>23.8 gal/min</b>	90 L/min	<b>23.8 gal/min</b>
Maximum Water Inlet Temperature	25° C/298,15 K	<b>77° F/298.15 K</b>	25° C/298,15 K	<b>77° F/298.15 K</b>
Shaft Design:				
Input Shaft (cylindrical)	<b>DIN 5480-W 140×4</b>		<b>DIN 5480-W 140×4</b>	
Output Shaft with Internal Toothing	<b>DIN 5480-N 360×10</b>		<b>DIN 5480-N 360×10</b>	



Rated Power P/Gearbox Ratio i [-]

CST30

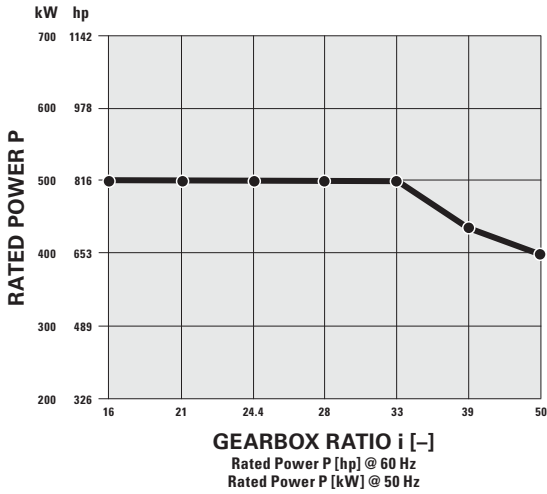

CST45 M

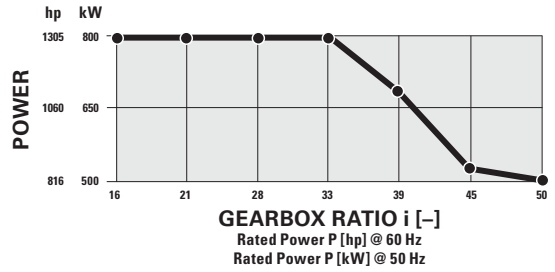

CST45

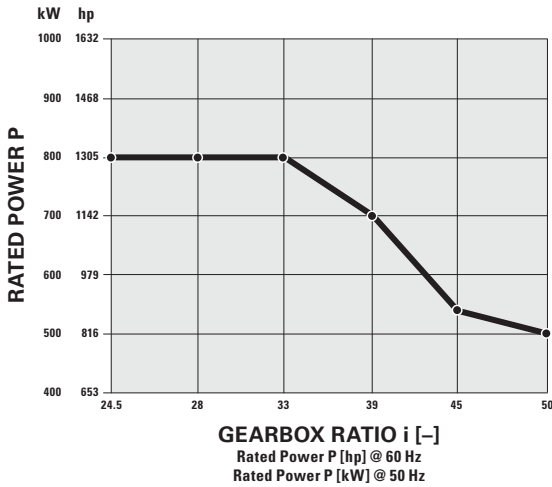

CST45 V

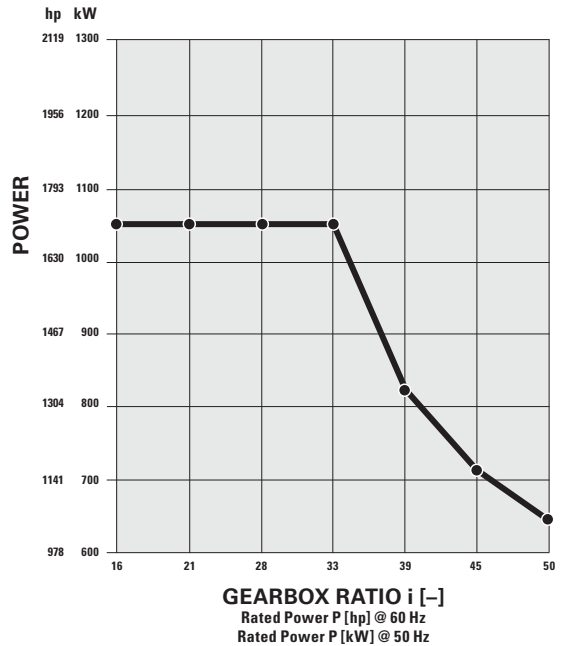

Rated Power P/Gearbox Ratio i [-]

CST65

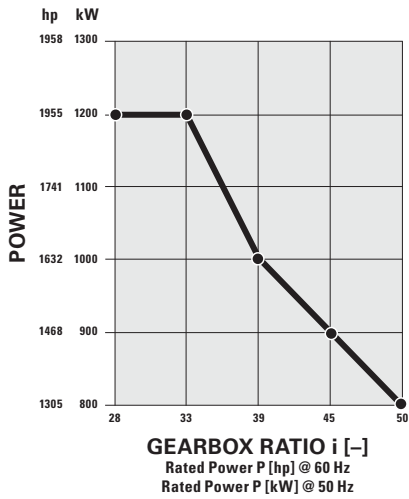

CST115

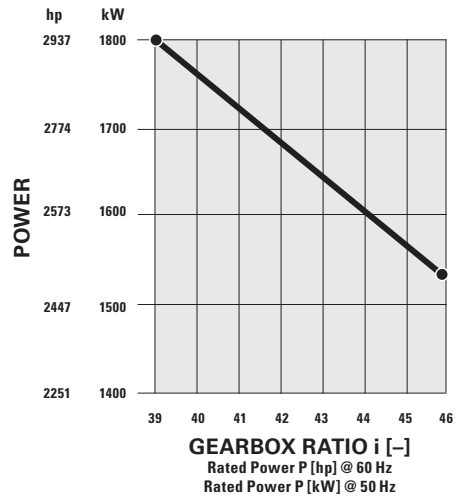

- Features

## Variable Frequency Drives

### Features

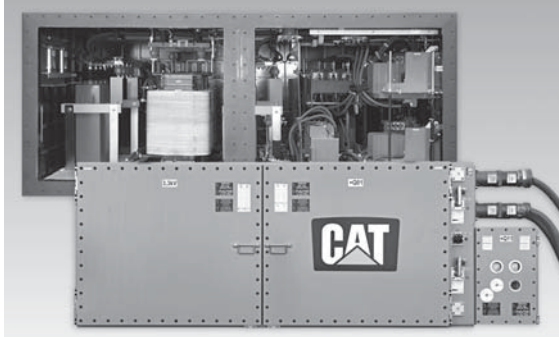

**Air-Cooled VFD Container**

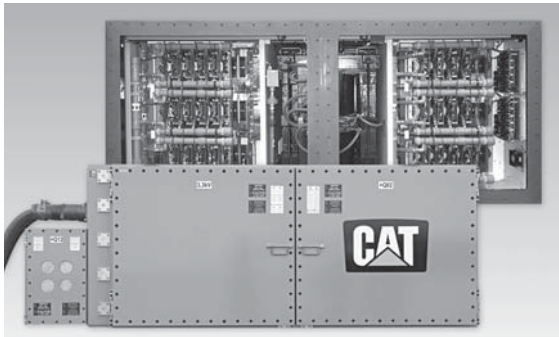

**Liquid-Cooled VFD Container**

The application of VFD brings a significant improvement for the plow and AFC operation. It implements among others the following advantages:

- **High Power System Stability/Quality**
  - Application of standard asynchronous motors.
  - Distance between motors and powering VFDs up to 4 kilometers (2.4 miles).
  - The usage of “weaker” networks is possible.
- **No EMC-Effects**
  - $du/dt$  is small, no special requirements to motor’s insulate performance.
  - No overvoltages and reflection waves.
  - No high-frequency interference by pulsing circuit of IGBT.
  - No network perturbations by large harmonic wave components.
  - No parasitic ground currents.
- **Variability/Dynamic of the Drive System**
  - Variable speed for AFC and plow in a wide range (0 to 120% of nominal speed).
  - Greater dynamic of drive system.
  - Unlimited start-ups of the motors.
  - No significant voltage drop during start-ups.
  - Reduction of mechanical stress.
- **Synchronicity and Precision/Utilization of the Full Power**
  - High constant torque throughout the entire speed range from 0 to maximum speed.
  - Full utilization of installed power on both plow’s motors through load shearing.
  - Synchronized start-up of all drives at full load.
  - Controlled load distribution between all drives.
  - Torque control function makes motor work with constant torque.
  - External encoder interface for speed feedback.
  - Moment and speed parameterizable.
- **Low Life Cycle Costs**
  - Reduction of impact of drive system on chain, line pans and chain sprockets.
  - Quick torque and speed reduction in case of blockades or chain cracks.
  - Improvement of overload protection for motors and chains.
  - Detection of chain break through controlled shut down.
- **Energy Recovery**
  - Breaking possibilities and thus returning power back to the network.
- **Maximum Torque at Zero Speed**
  - Total torque control at zero speed.
  - Tension of the chain without a chain tensioning unit.
- **Monitoring System**
  - System parameter (voltage, power, torque, effective power, speed, etc.) are directly (online) available.
- **Optional Functions**
  - Evenly distributed load of conveyor by adjustment of speed depending on the direction of motion of the extraction machine (optional).
  - Adjustment of profit performance depending on capacity utilization of downstream systems (optional).

**Specifications**

Model	VFD – A800/W800		VFD – A1200/W1200	
Rated Power	800 kW	1072 hp	1200 kW	1609 hp
Input Voltage	3300V ± 10%		3300V ± 10%	
Output Voltage	0-3300V		0-3300V	
Input Frequency	50/60 Hz ± 5%		50/60 Hz ± 5%	
Output Frequency	0-60 Hz		0-60 Hz	
Power Factor (cos phi)	>97.5% (PWM)		>97.5% (PWM)	
Slew Rate	20%-80% <20 m/sec	20%-80% <65.62 ft/sec	20%-80% <20 m/sec	20%-80% <65.62 ft/sec
Maximum Operational Torque	210%		210%	
Operation	4Q		4Q	
Converter	Current Source Inverter (CSI)		Current Source Inverter (CSI)	
Motor Type	AC motor		AC motor	
Setup	VFD separate from motor		VFD separate from motor	

**Current Source Converter**

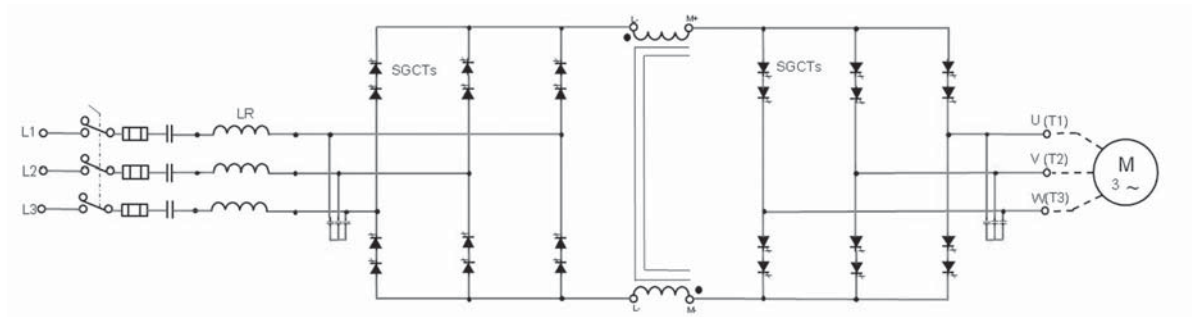

**Dimensions (All dimensions and weights are approximate.)**

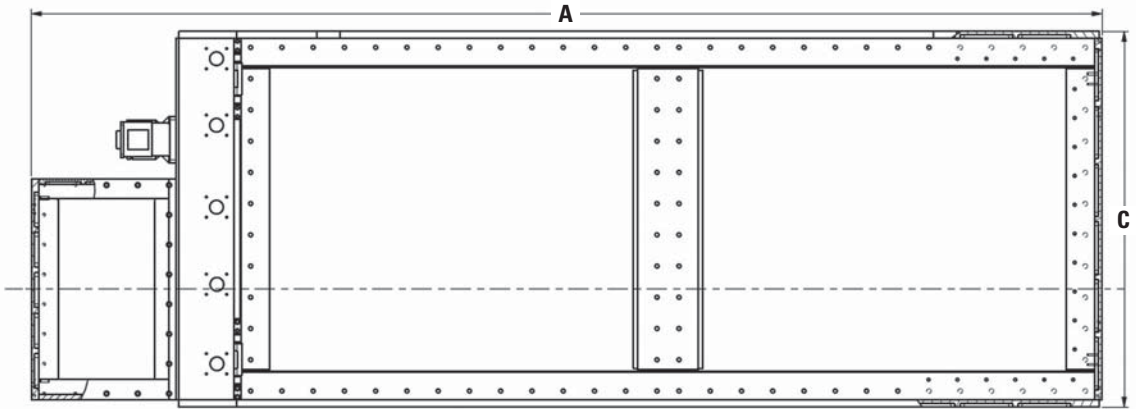

**Side View**

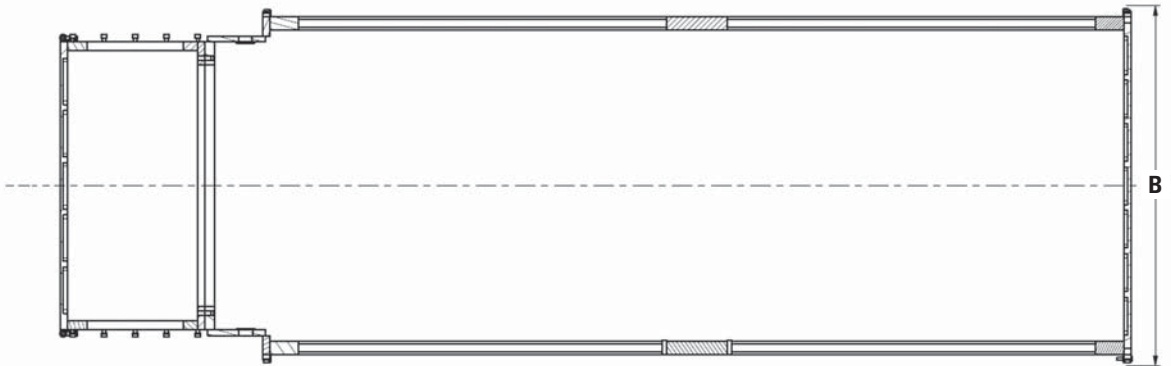

**Top View**

<b>A</b> Length	3700 mm	<b>146"</b>
<b>B</b> Width	1245 mm	<b>49"</b>
<b>C</b> Height	1300 mm	<b>51"</b>
Weight – VFD-A800 (air cooled)	6700 kg	<b>14,771 lb</b>
Weight – VFD-W800 (water cooled)	7800 kg	<b>17,196 lb</b>

## Shearers

### Features

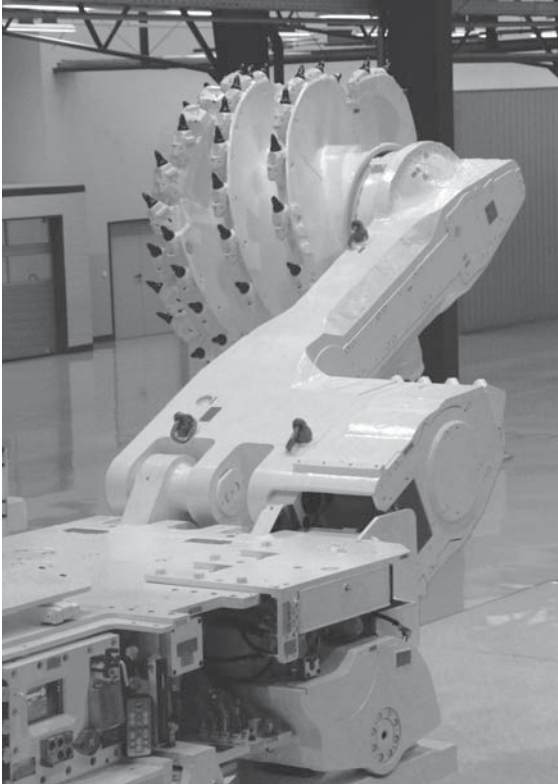

### Taking the Shearer to the Next Level

- Cat shearers meet the demands of the world's leading longwall operators in medium to high seam mining.
- Highest reliability due to own test center.
- Power for the toughest mining conditions.
- Robust design and unique mainframe concept.
- Unparalleled control with world-leading automation capabilities.
- Seam range: 1.8–7.0 m (5.9–23.0 ft).
- Installed power of up to 2295 kW (3078 hp), cutting speed up to 45 m/min (150 ft/min).
- Maximum capacity: 5000 tonnes/hr (6063 tons/hr).

### Specialized Shearers

Caterpillar also supplies shearers for specialized applications:

- Single- and double-drum low-seam shearer.
- Three-drum shearer for selective mining.

These shearers utilize the key feature of modular mainframe construction and are proven for coal and non-coal applications.

Specifications

Model	EL2000		EL3000		EL4000	
	Machine @ 50 Hz	Machine @ 60 Hz	Machine @ 50 Hz	Machine @ 60 Hz	Machine @ 50 Hz	Machine @ 60 Hz
Seam Range	1.8-4.5 m	<b>71-177"</b>	2.5-5.5 m	<b>98-217"</b>	4.0-7.0 m	<b>158-276"</b>
Typical Machine Length (drum centers)	14 155 mm	<b>46.2'</b>	15 200 mm	<b>49.9'</b>	17 008 mm	<b>55.8'</b>
Installed Power	Up to 1780 kW	<b>Up to 2387 hp</b>	Up to 2295 kW	<b>Up to 3680 hp</b>	Up to 2295 kW	<b>Up to 3680 hp</b>
Available Cutting Power:	2 x 500 kW 2 x 620 kW 2 x 750 kW	<b>2 x 800 hp 2 x 1000 hp 2 x 1200 hp</b>			2 x 860 kW 2 x 750 kW	<b>2 x 1380 hp 2 x 1200 hp</b>
RA860 Arms			2 x 860 kW	<b>2 x 1380 hp</b>		
RA860 Arms			2 x 750 kW	<b>2 x 1200 hp</b>		
RA750 Arms			2 x 620 kW	<b>2 x 1000 hp</b>		
RA750 Arms			2 x 750 kW	<b>2 x 1200 hp</b>		
Cutting Drum Diameter:	1600-2500 mm	<b>63-98.5"</b>			Up to 3500 mm	<b>Up to 138"</b>
RA860			Up to 2750 mm	<b>Up to 108"</b>		
RA750			Up to 2500 mm	<b>Up to 98"</b>		
Cutting Drum Speed:	32.8, 37.4 and 45.2 RPM	<b>39.4, 44.9 and 54.3 RPM</b>			30.8, 35 and 43 RPM	<b>37, 42 and 51.6 RPM</b>
RA860			30.8, 35 and 43 RPM	<b>37.42 and 51.6 RPM</b>		
RA750			32.8, 37.4 and 45.2 RPM	<b>39.4, 44.9 and 54.3 RPM</b>		
Haulage System	<b>AC Inverter Drive</b>		<b>AC Inverter Drive</b>		<b>AC Inverter Drive</b>	
Haulage Motor	2 x 125 kW	<b>2 x 168 hp</b>	2 x 150 kW	<b>2 x 240 hp</b>	2 x 150 kW	<b>2 x 240 hp</b>
Haulage Speed	Up to 30.1 m/min	<b>Up to 98.5 ft/min</b>	Up to 31.1 m/min	<b>Up to 98.7 ft/min</b>	Up to 31.1 m/min	<b>Up to 98.7 ft/min</b>
Haulage Pull	Up to 945 kN	<b>Up to 107 tons</b>	Up to 1075 kN	<b>Up to 123 tons</b>	Up to 1075 kN	<b>Up to 120 tons</b>
Pump Motor	30 kW	<b>40 hp</b>	75 kW	<b>120 hp</b>	75 kW	<b>120 hp</b>
Body Height	600 mm	<b>23.6"</b>	685 mm	<b>27"</b>	1070 mm	<b>42"</b>
Machine Weight (approximate)	70 tonnes	<b>77 tons</b>	105 tonnes	<b>116 tons</b>	130 tonnes	<b>143 tons</b>
Operating Voltage	3300V	<b>4160V</b>	3300V	<b>4160V</b>	3300V	<b>4160V</b>
Minimum Pan Width	1032 mm	<b>40.6"</b>	1132 mm	<b>44.6"</b>	1342 mm	<b>52.8"</b>
Coal Sizer		—	200 kW	<b>320 hp</b>	200 kW	<b>320 hp</b>

### Ranging Arms

Two types of ranging arm, both designed and robustly tested, for longer service life.

	RA750	RA860
EL2000	●	
EL3000	●	●
EL4000		●

### RA750

- Transmission rating of 750 kW @ 37.4 RPM and above
- Maximum drum diameter of 2500 mm (98 in)
- Choice of drum speeds
- Complete with 32 mm (1.3 in) bore, through shaft PFF/PBF wet cutting
- Square drum hub (440 mm [17.3 in] across flats)
- Maximum oil capacity of 28 L (7 gal) in high speed compartment and 30 L (8 gal) in the epicyclic
- Integral monitoring transducers
- Quillshaft transmission protection
- A robust cowl drive mechanism is also available on both models (EL2000, EL3000)
- Online vibration monitoring with VibraGuard
- Available cutting motors:
  - EL2000 500 kW, 620 kW and 750 kW @ 50 Hz (800 hp, 1000 hp and 1200 hp @ 60 Hz)
  - EL3000 620 kW and 750 kW @ 50 Hz (1000 hp and 1200 hp @ 60 Hz)

### RA860

- Transmission rating of 860 kW @ 30.8 RPM and above
- Maximum drum diameter:
  - EL3000 2750 mm (108 in)
  - EL4000 3500 mm (138 in)
- Choice of drum speeds
- Complete with 32 mm (1.3 in) bore, through shaft PFF/PBF wet cutting
- Square drum hub (630 mm [24.8 in] across flats)
- Maximum oil capacity of 45 L (12 gal) in high speed compartment and 60 L (15.85 gal) in the epicyclic
- Integral monitoring transducers
- Quillshaft transmission protection
- A robust cowl drive mechanism is also available
- Online vibration monitoring with VibraGuard
- Available cutting motors — 750 kW and 860 kW @ 50 Hz (1200 hp and 1380 hp @ 60 Hz)



**Haulage Units**

	HU125	HU150
EL2000	●	
EL3000		●
EL4000		●

**Haulage Unit — HU125**

Total Machine Pull	945.51 kN 96.80 tonnes	<b>212,559 lbf</b> <b>106.70 tons</b>
Speed at Maximum Pull	14.28 m/min	<b>46.83 ft/min</b>
Maximum Machine Speed	28.56 m/min	<b>93.66 ft/min</b>
Pull at Maximum Speed	472.75 kN 48.40 tonnes	<b>106,278 lbf</b> <b>53.35 tons</b>

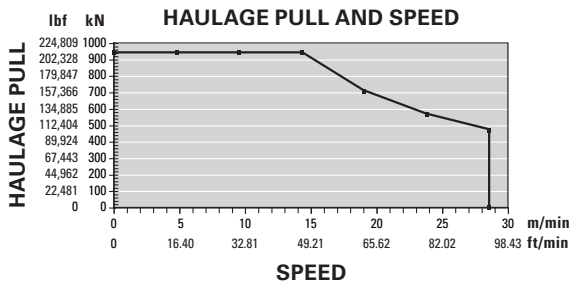

- Maximum power rating 125 kW (168 hp)
- Integral water cooling @ 9 L/min (2 gal/min)
- Transmission reduction of 137:1
- Maximum oil capacity of 25 L (7 gal)
- Integral monitoring transducers
- Quillshaft transmission protection
- This unit has a haulage motor rating of 125 kW (168 hp)
- Available with Machine Position Encoder
- Available with Machine Parking Brake

**Haulage Unit — HU150**

Total Machine Pull	1075.94 kN 110.15 tonnes	<b>241,881 lbf</b> <b>121.42 tons</b>
Speed at Maximum Pull	15.06 m/min	<b>49.39 ft/min</b>
Maximum Machine Speed	30.11 m/min	<b>98.77 ft/min</b>
Pull at Maximum Speed	537.97 kN 55.07 tonnes	<b>120,940 lbf</b> <b>60.70 tons</b>

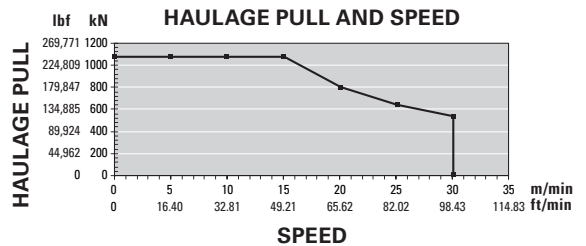

- Maximum power rating 150 kW (201 hp)
- Integral water cooling @ 9 L/min (2 gal/min)
- Transmission reduction of 137:1
- Maximum oil capacity of 25 L (7 gal)
- Integral monitoring transducers
- Quillshaft transmission protection
- This unit has a haulage motor rating of 150 kW (201 hp)
- Available with Machine Position Encoder
- Available with Machine Parking Brake
- Online vibration monitoring with VibraGuard

**Down Drives**

	DD125	DD150
EL2000	●	
EL3000		●
EL4000		●

**Down Drive — DD125/DD150**

- Innovative and unique downdrive design
- Transmission rating:  
DD125 125 kW (168 hp)  
DD150 150 kW (201 hp)
- Maximum haulage pull:  
DD125 945 kN (107 tons)  
DD150 1075 kN (123 tons)
- Fully removable, rehandable, modular gearbox
- Removable modular top drive wheel assembly (cartridge)
- Downdrive ratio:  
DD125 17T-23T-10T (two wheel configuration)  
**EL3000:**  
DD150 22T-31T-11T (two wheel configuration);  
available with three wheel configuration  
(27T idler)  
**EL4000:**  
DD150 22T-27T-31T-11T (three wheel configuration)
- Trapping shoe with replaceable wear inserts, safe and easy replace (unique to Caterpillar)
- Suitable for all current track-type systems

**Powerpack**

	PP2	PP3
EL2000	●	
EL3000		●
EL4000		●

**Powerpack — PP2/PP3**

- Fixed displacement pump, with a capacity of:  
PP2 50 L/min (13.21 gal/min)  
PP3 200 L/min (53 gal/min)
- Operating system pressure:  
PP2 260 bar (3770 psi)  
PP3 210 bar (3046 psi)
- Robust hydraulic reservoir; capacity:  
PP2 165 L (43.6 gal)  
PP3 300 L (79 gal)
- Integral monitoring transducers
- For use with ISO 68 or ISO 100 hydraulic oils
- Available with 6 (PP2, PP3) or 8 (PP3) valve bank (dependent on function requirement)
- Available with two speed ranging arm facility (EL4000)
- This unit has a pump motor rating of:  
PP2 30 kW @ 50 Hz (48 hp @ 60 Hz)  
PP3 75 kW @ 50 Hz (120 hp @ 60 Hz)

**Mainframe**

	MF2	MF3	MF4
EL2000	●		
EL3000		●	
EL4000			●

**Mainframe — MF2/MF3/MF4**

- High structural integrity and absorption of all cutting and haulage forces, providing maximum protection of all major units
- Maximum protection of electrical boxes, providing the highest level of flameproof integrity
- Improved access for maintenance and ease of overhaul and repair
- Versatility of application due to fully modular construction
- A split mainframe is available in case of transportation limitations

**Hydraulically Activated Top Guards**

- EL3000 and EL4000 are equipped with hydraulically activated top guards

**Electrical Control Box**

	ECB2	ECB3
EL2000	●	
EL3000		●
EL4000		●

**Electrical Control Box — MF2/MF3/MF4**

- This flameproof module contains the majority of the shearer electrical control and power distribution components
- High current carrying capacity of 400 amps (ECB2) or 500 amps (ECB3) and can accommodate trailing cables up to 185 mm<sup>2</sup> [ECB2] (2.9 in<sup>2</sup>) or 240 mm<sup>2</sup> [ECB3] (9.4 in<sup>2</sup>)
- All internal chassis can be ‘bench built,’ tested and stored
- Box contains various low voltage (LV) circuit breakers which can be reset through the flameproof cover (FLP) cover, reducing downtime
- An extremely powerful PMC Evo-S control system with state-of-the-art Ethernet communication and backup functionality, this allows the shearer to be operated even if the overall control system is not functioning
- This unit also contains cutter motor contactors, circuit breakers, control transformers, current monitoring, high voltage (HV) fuses, earth leakage and both visible disconnects

### Haulage Transformer Box

	HTB2	HTB3
EL2000	●	
EL3000		●
EL4000		●

### Haulage Transformer Box — HTB2/HTB3

- This flameproof model contains the main 253 kVA (HTB2)/350 kVA (HTB3) haulage transformers, power supplies, auxiliary transformer, drive system circuit breaker and  
HTB2 one 250 kW, 600V AC inverter drive  
HTB3 two 200 kW, 600V AC inverter drives with regenerative braking module

### Electrical Material

- All three models are available with headlights, cameras, methane monitoring, end displays and audible alarms
- All electrical material is designed and certified to IEC standards and also complies with other regional and national standards, such as MSHA, EAC/Ex, MA, ATEX and DGMS, as well as Australia's New South Wales and Queensland regulations

### Hydraulic Material

- All hose assemblies are to ISO 6805 and proof tested to EN ISO 1402
- The hoses are assembled to Hose Assembly Standard DIN20066:201-10
- All hose and hosing is in compliance with guideline MDG 41 and MSHA regulations

### Water Material

- All hose assemblies are to ISO 6805 and proof tested to EN ISO 1402
- The hoses are assembled to Hose Assembly Standard DIN20066:201-10
- All hose and hosing is in compliance with guideline MDG 41 and MSHA regulations
- All three models are available with onboard filtration, dust suppression spray bars, shearer clearers and ranging arms spray rings

### Health Monitoring

- A comprehensive health monitoring system is available, including oil levels and temperatures, flows, pressures and vibration analysis

**Machine Automation and Communication**

- Industry-leading Automation from the Pioneer of State-based Automation.
- The shearers have a state-of-the-art distributed automation system for the control, monitoring and protection of the shearers. Its modular design allows it to be configured to meet individual control needs, from basic monitoring and protection to advanced automation and data transmission.
- The PMC Evo-S control system with state-of-the-art Ethernet communication and backup functionality allows the shearer to be operated even if the overall control system is not functioning.
- The shearer is equipped with a state-of-the-art industry PC in a flameproof housing with plenty of computing power, allowing flexibility to upgrade to future features such as condition monitoring.
- A Programmable Logic Controller (PLC) takes care of basic machine control tasks, ensuring that coal is produced.
- Unlike competitor systems, the modularity of the longwall system to operate in “fault-tolerant” mode, even when there is a problem with the overall automation system.
- In other words, integrated automation does not prevent control via individual PLC’s in order to keep production up and running.
- Levels of automation:
  - Zone-based automation “Navigator 1”
  - State-based shearer automation “Navigator 2”
  - Integrated longwall automation with “Navigator 2+3”
  - “Longwall Navigator” for improved face alignment and horizon control

**Optional Machine Mounted Coal Sizer — CS200 (EL3000 and EL4000)**

- Transmission rating of 200 kW @ 50 Hz (320 hp @ 60 Hz)
- Quillshaft transmission protection
- Drum speed of 200 RPM (240 @ 60 Hz)
- Drum diameter 900 mm (35.5 in) over picks
- Integral water cooling for transmission and motor
- Square drum hub drive for drum
- Complete with anti-shock lift mechanism (unique to Caterpillar)
- Available motor rating 200 kW @ 50 Hz (320 hp @ 60 Hz)

EL2000 Longwall Shearer

Typical Machine Configurations (Machine Sketch)

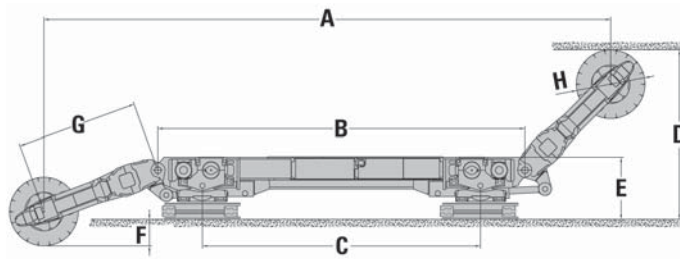

Low

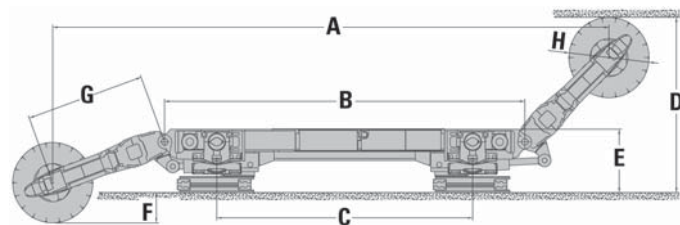

Mid-Low

Dimensions (All dimensions are approximate.)

	Low		Mid-Low	
<b>A</b> Distance between Drums with Arms Horizontal	14 155 mm	537"	14 155 mm	537"
<b>B</b> Distance between Ranging Arm Hinge Points	8525 mm	336"	8525 mm	336"
<b>C</b> Distance between Trapping Shoe Centers	6453 mm	254"	6056 mm	238"
<b>D</b> Cutting Heights:				
Maximum	3930 mm	155"	4135 mm	163"
Minimum	1800 mm	71"	1900 mm	75"
<b>E</b> Height to Top of Machine Main Body	1444 mm	56.8"	1495 mm	58.8"
<b>F</b> Shearer Drum Undercut of Floor	619 mm	24"	718 mm	28.3"
<b>G</b> Ranging Arm Length (Hinge to Drum)	2815 mm	111"	2815 mm	111"
<b>H</b> Diameter of Shearer Cutting Drum	1600 mm	63"	1900 mm	75"

EL2000 Longwall Shearer

Typical Machine Configurations (Machine Sketch)

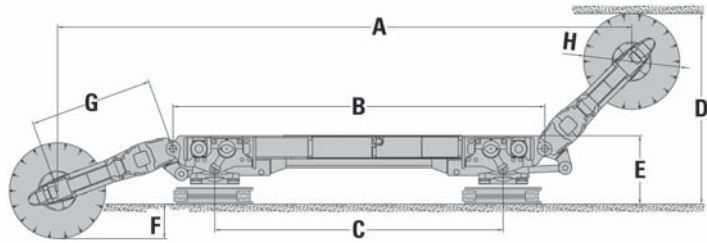

Mid-High

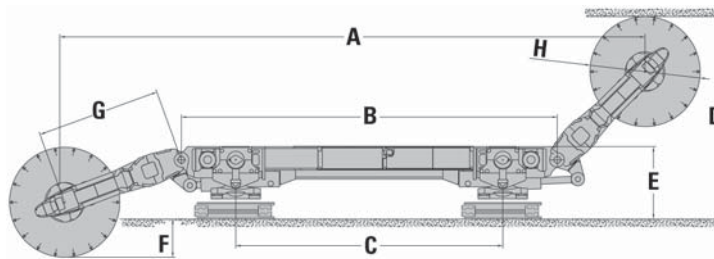

High

Dimensions (All dimensions are approximate.)

	Mid-High		High	
<b>A</b> Distance between Drums with Arms Horizontal	14 155 mm	<b>537"</b>	14 155 mm	<b>537"</b>
<b>B</b> Distance between Ranging Arm Hinge Points	8525 mm	<b>336"</b>	8525 mm	<b>336"</b>
<b>C</b> Distance between Trapping Shoe Centers	6612 mm	<b>260"</b>	6065 mm	<b>238"</b>
<b>D</b> Cutting Heights:				
Maximum	4360 mm	<b>172"</b>	4570 mm	<b>180"</b>
Minimum	2200 mm	<b>87"</b>	2500 mm	<b>98"</b>
<b>E</b> Height to Top of Machine Main Body	1571 mm	<b>61.8"</b>	1647 mm	<b>64.8"</b>
<b>F</b> Shearer Drum Undercut of Floor	793 mm	<b>31.2"</b>	866 mm	<b>34"</b>
<b>G</b> Ranging Arm Length (Hinge to Drum)	2815 mm	<b>111"</b>	2815 mm	<b>111"</b>
<b>H</b> Diameter of Shearer Cutting Drum	2200 mm	<b>87"</b>	2500 mm	<b>98"</b>

**EL2000 Longwall Shearer**

**Typical Machine Configurations (Cross Section)**

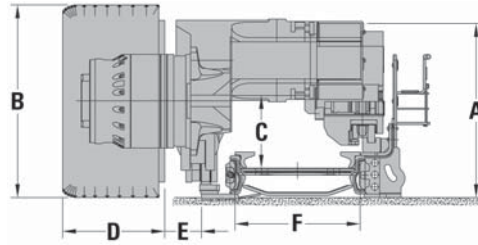

**Low**

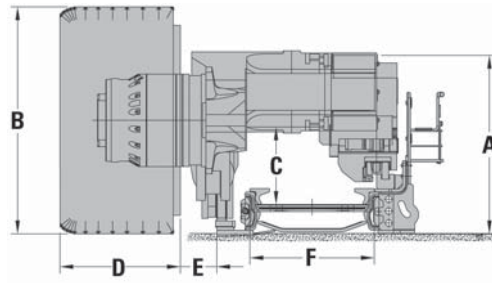

**Mid-Low**

**Dimensions (All dimensions are approximate.)**

	<b>Low</b>		<b>Mid-Low</b>	
<b>A</b> Machine Height over Main Body	1444 mm	<b>56.8"</b>	1495 mm	<b>58.8"</b>
<b>B</b> Ranging Arm Cutting Drum Diameter	1600 mm	<b>63"</b>	1900 mm	<b>75"</b>
<b>C</b> Vertical Tunnel Clearance	598 mm	<b>23.5"</b>	649 mm	<b>25.5"</b>
<b>D</b> Maximum Cutting Drum Overall Width	1150 mm	<b>45.3"</b>	1150 mm	<b>45.3"</b>
<b>E</b> Clearance from Drum to AFC Toeplate	300 mm	<b>12"</b>	300 mm	<b>12"</b>
<b>F</b> AFC Pan Width:				
Maximum	1342 mm	<b>53"</b>	1342 mm	<b>53"</b>
Minimum	1032 mm	<b>41"</b>	1032 mm	<b>41"</b>



EL2000 Longwall Shearer

Typical Machine Configurations (Cross Section)

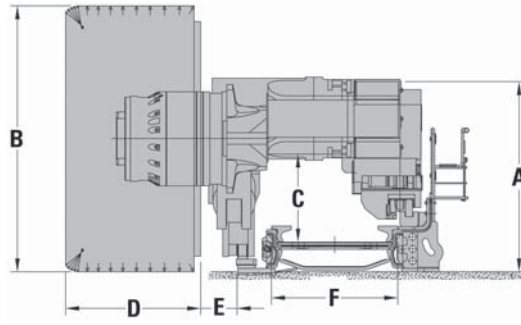

Mid-High

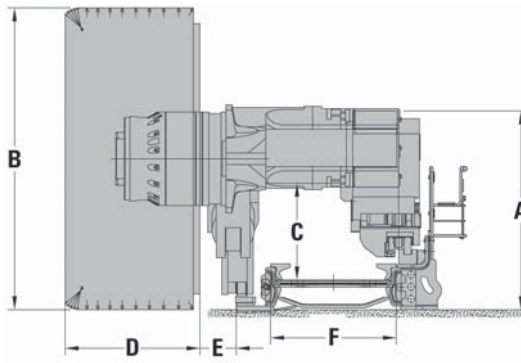

High

Dimensions (All dimensions are approximate.)

	Mid-High		High	
<b>A</b> Machine Height over Main Body	1571 mm	<b>61.8"</b>	1647 mm	<b>64.8"</b>
<b>B</b> Ranging Arm Cutting Drum Diameter	2200 mm	<b>87"</b>	2500 mm	<b>98"</b>
<b>C</b> Vertical Tunnel Clearance	725 mm	<b>28.5"</b>	801 mm	<b>31.5"</b>
<b>D</b> Maximum Cutting Drum Overall Width	1150 mm	<b>45.3"</b>	1150 mm	<b>45.3"</b>
<b>E</b> Clearance from Drum to AFC Toeplate	300 mm	<b>12"</b>	300 mm	<b>12"</b>
<b>F</b> AFC Pan Width:				
Maximum	1342 mm	<b>53"</b>	1342 mm	<b>53"</b>
Minimum	1032 mm	<b>41"</b>	1032 mm	<b>41"</b>

EL3000 Longwall Shearer

Typical Machine Configurations (Machine Sketch)

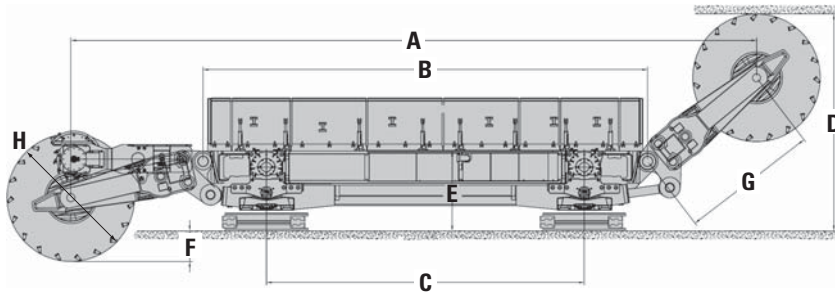

Low

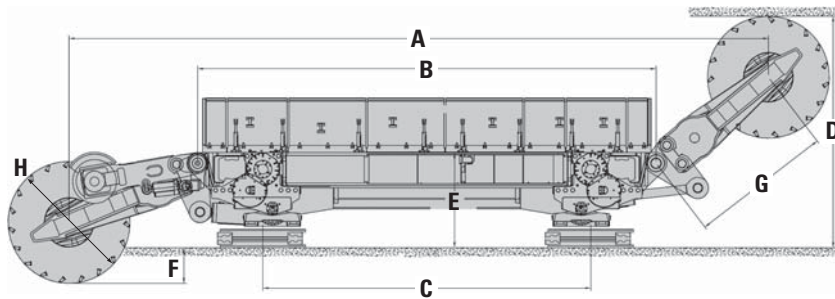

Medium

Dimensions (All dimensions are approximate.)

	Low		Medium	
<b>A</b> Distance between Drums with Arms Horizontal	15 200 mm	598"	15 200 mm	598"
<b>B</b> Distance between Ranging Arm Hinge Points	9400 mm	370"	9400 mm	370"
<b>C</b> Distance between Trapping Shoe Centers	6724 mm	265"	6332 mm	249"
<b>D</b> Maximum Cutting Height for Seam	4400 mm	173"	4500 mm	177"
<b>E</b> Height to Top of Machine Main Body	1690 mm	67"	1950 mm	77"
<b>F</b> Shearer Drum Undercut of Floor	550 mm	22"	519 mm	21"
<b>G</b> Ranging Arm Length (Hinge to Drum)	2900 mm	114"	2900 mm	114"
<b>H</b> Diameter of Shearer Cutting Drum	2600 mm	102"	2700 mm	106"

EL3000 Longwall Shearer

Typical Machine Configurations (Machine Sketch)

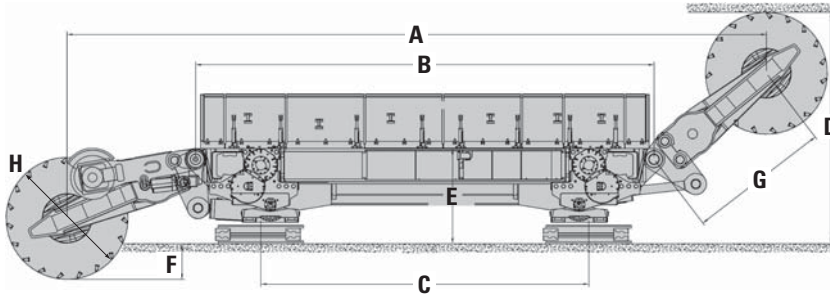

High

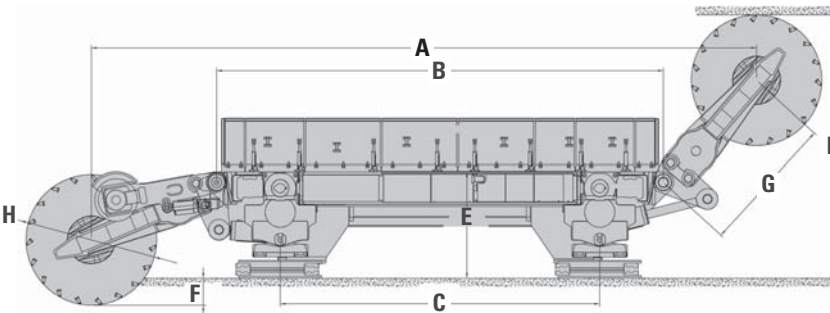

Super-High

Dimensions (All dimensions are approximate.)

	High		Super-High	
<b>A</b> Distance between Drums with Arms Horizontal	15 200 mm	<b>598"</b>	15 200 mm	<b>598"</b>
<b>B</b> Distance between Ranging Arm Hinge Points	9400 mm	<b>370"</b>	9400 mm	<b>370"</b>
<b>C</b> Distance between Trapping Shoe Centers	6724 mm	<b>264"</b>	6724 mm	<b>265"</b>
<b>D</b> Maximum Cutting Height for Seam	4500 mm	<b>177"</b>	5532 mm	<b>218"</b>
<b>E</b> Height to Top of Machine Main Body	2110 mm	<b>83"</b>	2240 mm	<b>88"</b>
<b>F</b> Shearer Drum Undercut of Floor	510 mm	<b>20"</b>	567 mm	<b>22"</b>
<b>G</b> Ranging Arm Length (Hinge to Drum)	2900 mm	<b>114"</b>	2900 mm	<b>114"</b>
<b>H</b> Diameter of Shearer Cutting Drum	2700 mm	<b>106"</b>	2750 mm	<b>108"</b>

**EL3000 Longwall Shearer**

**Typical Machine Configurations (Cross Section)**

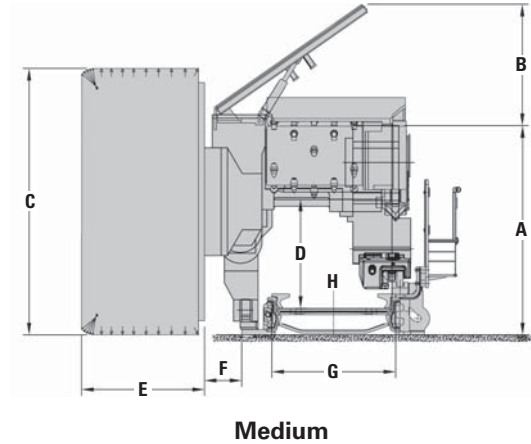
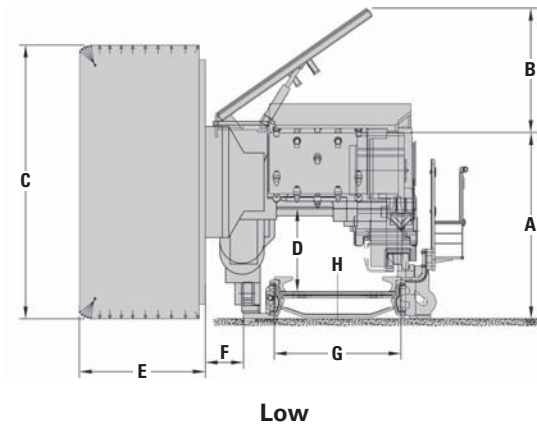

**Dimensions (All dimensions are approximate.)**

	<b>Low</b>		<b>Medium</b>	
<b>A</b> Machine Height over Main Body	1690 mm	<b>67"</b>	1950 mm	<b>77"</b>
<b>B</b> Top Guard Height over Main Body	1124 mm	<b>44"</b>	1124 mm	<b>44"</b>
<b>C</b> Ranging Arm Cutting Drum Diameter	2700 mm	<b>106"</b>	2700 mm	<b>106"</b>
<b>D</b> Vertical Tunnel Clearance	800 mm	<b>32"</b>	1000 mm	<b>39"</b>
<b>E</b> Cutting Drum Overall Width	1100 mm	<b>43"</b>	1100 mm	<b>43"</b>
<b>F</b> Clearance from Drum to AFC Toeplate	344 mm	<b>14"</b>	344 mm	<b>14"</b>
<b>G</b> AFC Pan Width	1142 mm	<b>45"</b>	1142 mm	<b>45"</b>
<b>H</b> CSA	0.57 m <sup>2</sup>	<b>6.1 ft<sup>2</sup></b>	0.80 m <sup>2</sup>	<b>8.6 ft<sup>2</sup></b>

**EL3000 Longwall Shearer**

**Typical Machine Configurations (Cross Section)**

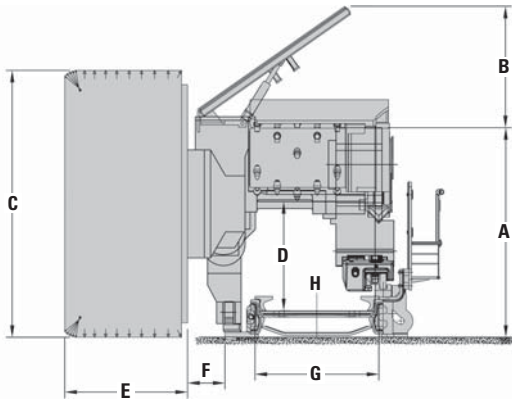

**High**

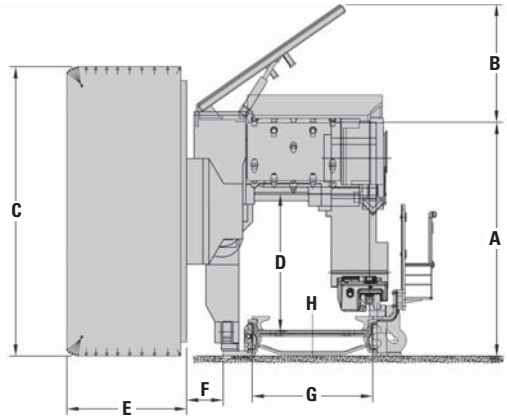

**Super-High**

**Dimensions (All dimensions are approximate.)**

	<b>High</b>		<b>Super-High</b>	
<b>A</b> Machine Height over Main Body	2110 mm	<b>88"</b>	2240 mm	<b>88"</b>
<b>B</b> Top Guard Height over Main Body	1124 mm	<b>44"</b>	1124 mm	<b>44"</b>
<b>C</b> Ranging Arm Cutting Drum Diameter	2700 mm	<b>106"</b>	2750 mm	<b>108"</b>
<b>D</b> Vertical Tunnel Clearance	1160 mm	<b>45"</b>	1300 mm	<b>51"</b>
<b>E</b> Cutting Drum Overall Width	1100 mm	<b>43"</b>	1100 mm	<b>43"</b>
<b>F</b> Clearance from Drum to AFC Toeplate	344 mm	<b>14"</b>	344 mm	<b>14"</b>
<b>G</b> AFC Pan Width	1142 mm	<b>45"</b>	1142 mm	<b>45"</b>
<b>H</b> CSA	0.95 m <sup>2</sup>	<b>10.2 ft<sup>2</sup></b>	1.06 m <sup>2</sup>	<b>11.4 ft<sup>2</sup></b>

EL4000 Longwall Shearer

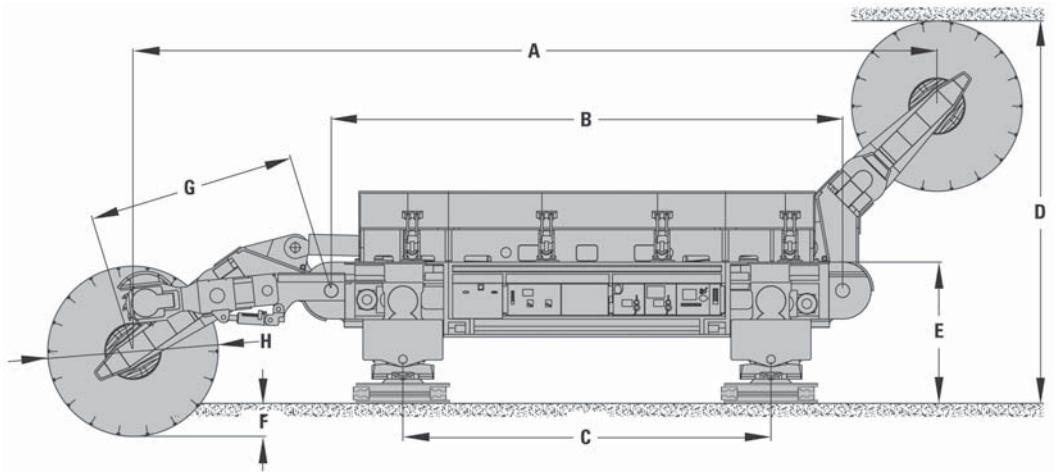

Dimensions (All dimensions are approximate.)

Model	EL3000	
<b>A</b> Distance between Drums with Arms Horizontal	17 008 mm	670"
<b>B</b> Distance between Ranging Arm Hinge Points	9600 mm	378"
<b>C</b> Distance between Trapping Shoe Centers	6910 mm	272"
<b>D</b> Maximum Cutting Height for Seam	7188 mm	283"
<b>E</b> Height to Top of Machine Main Body	2656 mm	105"
<b>F</b> Shearer Drum Undercut of Floor	621 mm	24"
<b>G</b> Ranging Arm Length (Hinge to Drum)	3893 mm	153"
<b>H</b> Diameter of Shearer Cutting Drum	3200 mm	126"

EL4000 Longwall Shearer

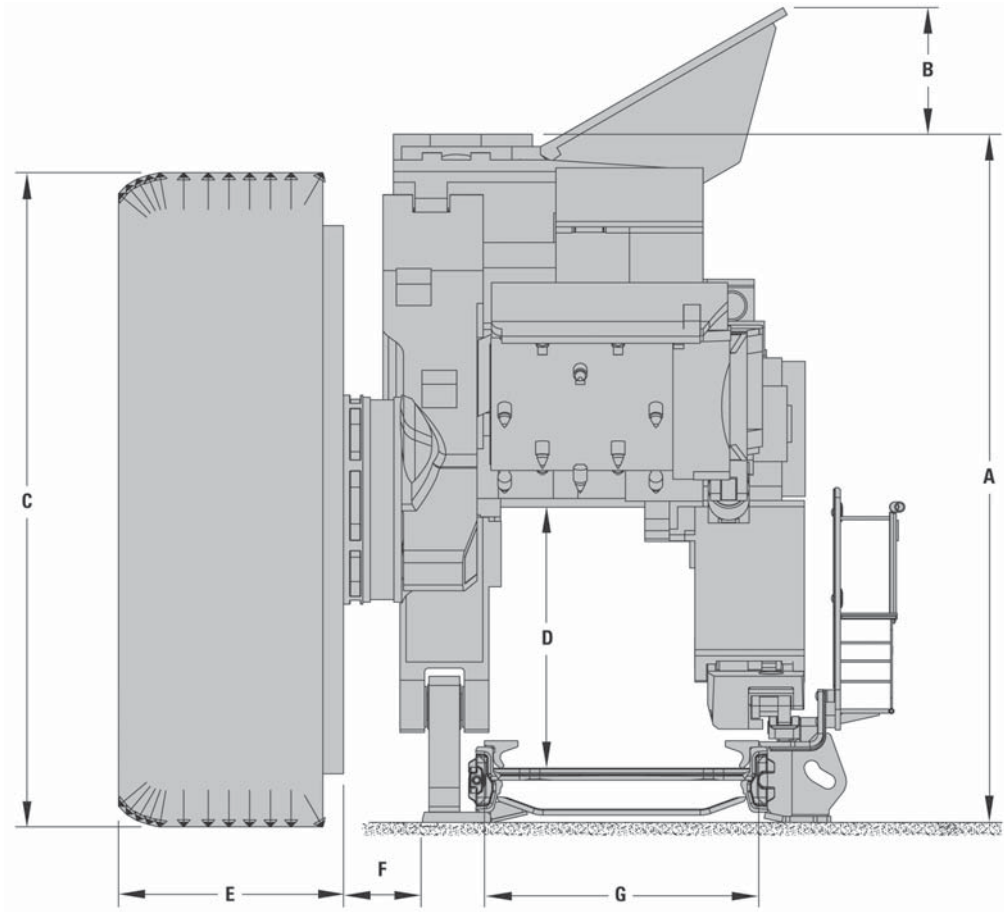

Dimensions (All dimensions are approximate.)

Model	EL3000	
<b>A</b> Machine Height over Main Body	3366 mm	133"
<b>B</b> Top Guard Height over Main Body	620 mm	24"
<b>C</b> Ranging Arm Cutting Drum Diameter	3200 mm	126"
<b>D</b> Vertical Tunnel Clearance	1277 mm	50"
<b>E</b> Cutting Drum Overall Width	1100 mm	43"
<b>F</b> Clearance from Drum to AFC Toeplate	380 mm	15"
<b>G</b> AFC Pan Width	1342 mm	53"

**Optional Accessories**

Model	EL2000	EL3000	EL4000
Multi-piece Mainframe	○	○	○
Cowl	○	○	○
Spall Guards	○	○	○
Coal Sizer:			
100 kW (134 hp)	○	○	○
200 kW (268 hp)	–	○	○
Trapping Shoe Ix (Insert Exchange)	● ○	● ○	● ○
Shearer Clearer	○	○	○
Spray Bars	○	○	○
Central Lubrication System	●	●	●
PMC Evo-S	●	●	●
Gate End Data Connection:			
Powerline	●	●	●
Fiber Optics	–	○	○
WLAN	●	●	●
IPC	○	○	○
Zone-based Automation “Navigator 1”	○	○	○
State-based Shearer Automation “Navigator 2”	○	○	○
Integrated Longwall Automation with “Navigator 2 + 3”	○*	○*	○*
“Longwall Navigator” for Improved Face Alignment and Horizon Control Incorporating LASC Technology	○*	○*	○*
VibraGuard	○	○	○
Cameras	○	○	○
Condition Monitoring	○	○	○

- = Standard equipment
- = Available equipment
- \* = Only with Cat longwall equipment



## AUTOMATED PLOW SYSTEMS

### Features

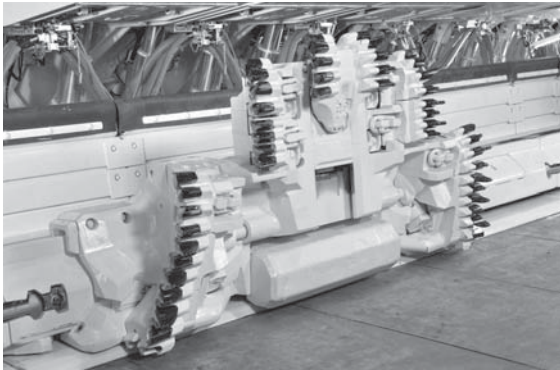

### High-level Automation

- Preferred longwall mining machine for seams under 1.8 m (5.9 ft).
- Fully automated longwall mining system for medium and thin seams from 0.8–2.3 m (1.8–7.5 ft).
- High traveling speed up to 3.6 m/sec (720 ft/min).
- Most powerful system available with up to  $2 \times 800$  kW ( $2 \times 1080$  hp).
- Maximum capacity 3500 tonnes/hr (3858 tons/hr).
- Overload protection.
- Load sharing.
- Minimum dust generation.
- Low operating costs.
- Effective horizon control and incremental plowing for full automation without operators being required on the face.

**Gliding Plow  
GH800**

<b>Model</b>	<b>Base-Plate Plow RHH800</b>		<b>Gliding Plow GH800</b>	
Plow Length — Single Plow	2384 mm	<b>7.82 ft</b>	2712 mm	<b>8.89 ft</b>
Plow Heights	600-855 mm 820-1120 mm 1085-1385 mm 1350-1650 mm	<b>1.97-2.81 ft</b> <b>2.70-3.67 ft</b> <b>3.56-4.54 ft</b> <b>4.43-5.41 ft</b>	800-1060 mm 1020-1320 mm 1285-1585 mm	<b>2.62-3.47 ft</b> <b>3.34-4.33 ft</b> <b>4.21-5.20 ft</b>
Plow Heights (with gobside support)	—		1570-1735 mm 1700-2000 mm	<b>5.15-5.69 ft</b> <b>5.57-6.56 ft</b>
Mechanical Height Adjustment	255-300 mm	<b>0.83-0.98 ft</b>	180-300 mm	<b>0.59-0.98 ft</b>
Cutting Depth	max. 190 mm	<b>max 0.62 ft</b>	195 mm	<b>0.64 ft</b>
Weights:	4400-6400 kg	<b>9700-14,109 lb</b>	—	
Single Plow	—		4080-6630 kg	<b>8995-14,616 lb</b>
Bottom Bit Positions:				
Position 1	+24 mm	<b>+0.08 ft</b>	+12 mm	<b>+0.04 ft</b>
Position 2	-5 mm	<b>-0.02 ft</b>	-10 mm	<b>-0.03 ft</b>
Position 3	-18 mm	<b>-0.06 ft</b>	-20 mm	<b>-0.06 ft</b>
Position 4	-37 mm	<b>-0.12 ft</b>	-34 mm	<b>-0.11 ft</b>
Maximum Drive Power	2 × 400 kW	<b>2 × 536 hp</b>	2 × 400 kW	<b>2 × 536 hp</b>
Coal Hardness	<b>Soft-hard coal</b>		<b>Soft-hard coal</b>	
Maximum Seam Inclination	<b>Up to 60°</b>		<b>Up to 60°</b>	
Maximum Plow Speed	2.5 m/sec	<b>500 ft/min</b>	3.0 m/sec	<b>600 ft/min</b>

<b>Model</b>	<b>Gliding Plow GH800B</b>		<b>Gliding Plow GH1600</b>	
	Plow Length — Single Plow	2636 mm	<b>8.65 ft</b>	2969 mm
Plow Heights	750-1030 mm	<b>2.64-3.38 ft</b>	980-1230 mm	<b>3.22-4.04 ft</b>
	1000-1285 mm	<b>3.28-4.22 ft</b>	1180-1480 mm	<b>3.87-4.86 ft</b>
	1270-1550 mm	<b>4.17-5.09 ft</b>	1445-1745 mm	<b>4.73-5.73 ft</b>
Plow Heights (with gobside support)	1535-1700 mm	<b>5.04-5.58 ft</b>	1860-2160 mm	<b>6.10-7.08 ft</b>
	1685-1965 mm	<b>5.53-6.45 ft</b>		
Mechanical Height Adjustment	180-280 mm	<b>0.59-0.92 ft</b>	180-300 mm	<b>0.59-0.98 ft</b>
Cutting Depth	205 mm	<b>0.67 ft</b>	210 mm	<b>0.69 ft</b>
Weights:	—		5600-8600 kg	<b>12,345-18,960 lb</b>
Single Plow	4385-5625 kg	<b>10,660-12,401 lb</b>	—	
Bottom Bit Positions:				
Position 1	+19 mm	<b>+0.06 ft</b>	+12 mm	<b>+0.04 ft</b>
Position 2	-9 mm	<b>-0.03 ft</b>	-10 mm	<b>-0.03 ft</b>
Position 3	-22 mm	<b>-0.07 ft</b>	-21 mm	<b>-0.07 ft</b>
Position 4	-39 mm	<b>-0.13 ft</b>	-35 mm	<b>-0.11 ft</b>
Maximum Drive Power	2 × 400 kW	<b>2 × 536 hp</b>	2 × 800 kW	<b>2 × 1080 hp</b>
Coal Hardness	<b>Soft-hard coal</b>		<b>Medium-extremely hard coal</b>	
Maximum Seam Inclination	<b>60°</b>		<b>Up to 60°</b>	
Maximum Plow Speed	3.0 m/sec	<b>600 ft/min</b>	3.6 m/sec	<b>720 ft/min</b>

Dimensions RHH800 — Plow Body Setup Option 1 (All dimensions are approximate.)

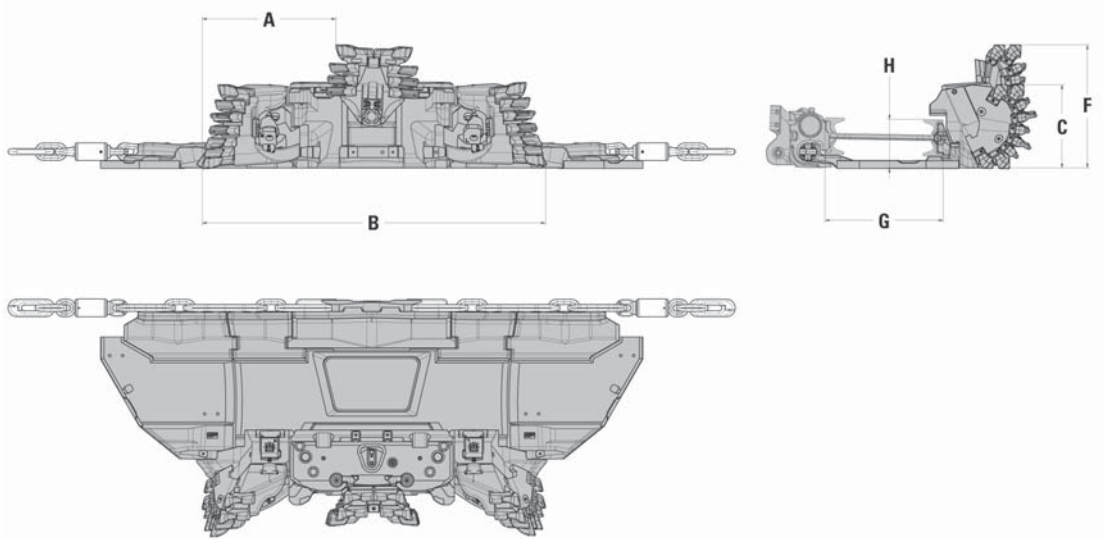

Model	RHH800 — Plow Body Setup Option 1		
A	930 mm		3.05 ft
B	2384 mm		7.82 ft
C	579 mm		1.90 ft
D		—	
E		—	
F	855 mm		2.81 ft
G	822 mm		2.70 ft
H	377 mm		1.11 ft

**Dimensions RHH800 – Plow Body Setup Option 2 (All dimensions are approximate.)**

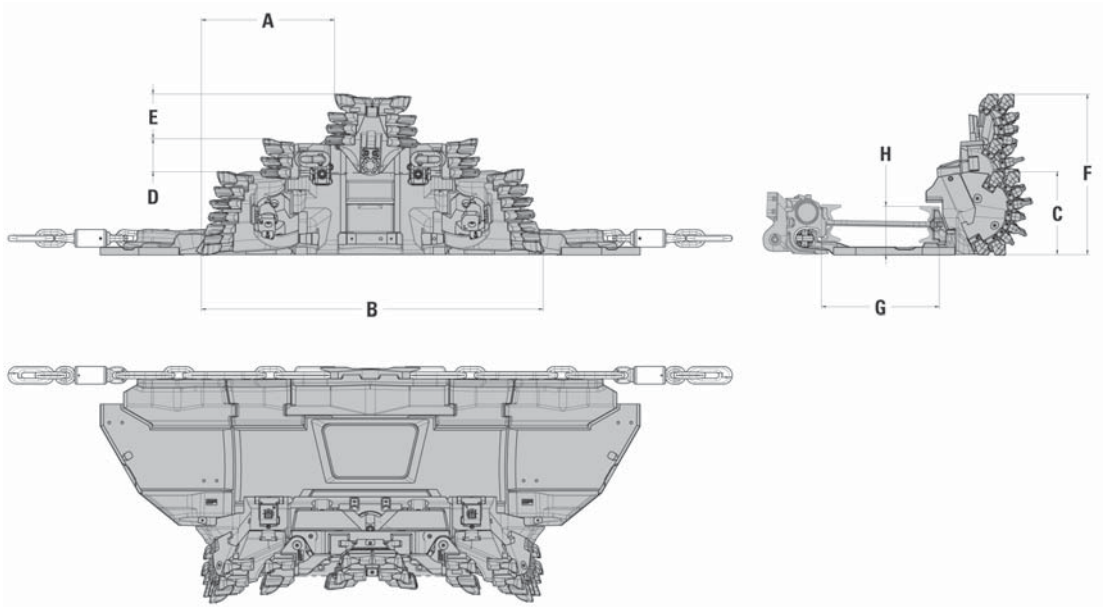

**Model**

**RHH800 – Plow Body Setup Option 2**

<b>A</b>	930 mm	3.05 ft
<b>B</b>	2384 mm	7.82 ft
<b>C</b>	579 mm	1.90 ft
<b>D</b>	229 mm	0.75 ft
<b>E</b>	312 mm	1.02 ft
<b>F</b>	1120 mm	3.67 ft
<b>G</b>	822 mm	2.70 ft
<b>H</b>	377 mm	1.11 ft

**Dimensions RHH800 — Plow Body Setup Option 3 (All dimensions are approximate.)**

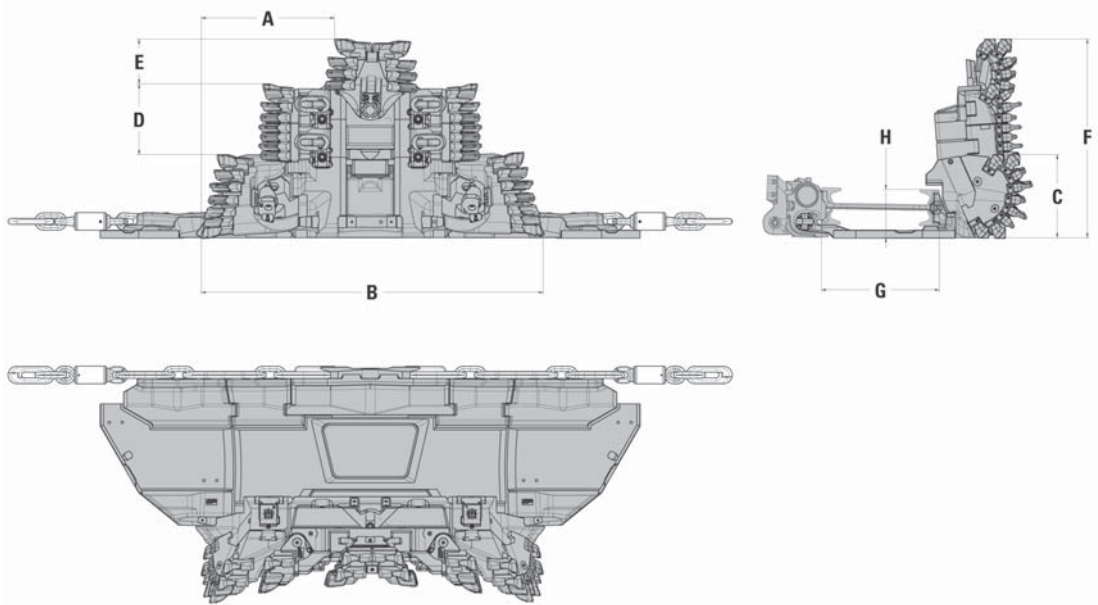

**Model**

**RHH800 — Plow Body Setup Option 3**

<b>A</b>	930 mm	3.05 ft
<b>B</b>	2384 mm	7.82 ft
<b>C</b>	579 mm	1.90 ft
<b>D</b>	494 mm	1.62 ft
<b>E</b>	312 mm	1.02 ft
<b>F</b>	1385 mm	4.54 ft
<b>G</b>	822 mm	2.70 ft
<b>H</b>	377 mm	1.11 ft

**Dimensions RHH800 — Plow Body Setup Option 4 (All dimensions are approximate.)**

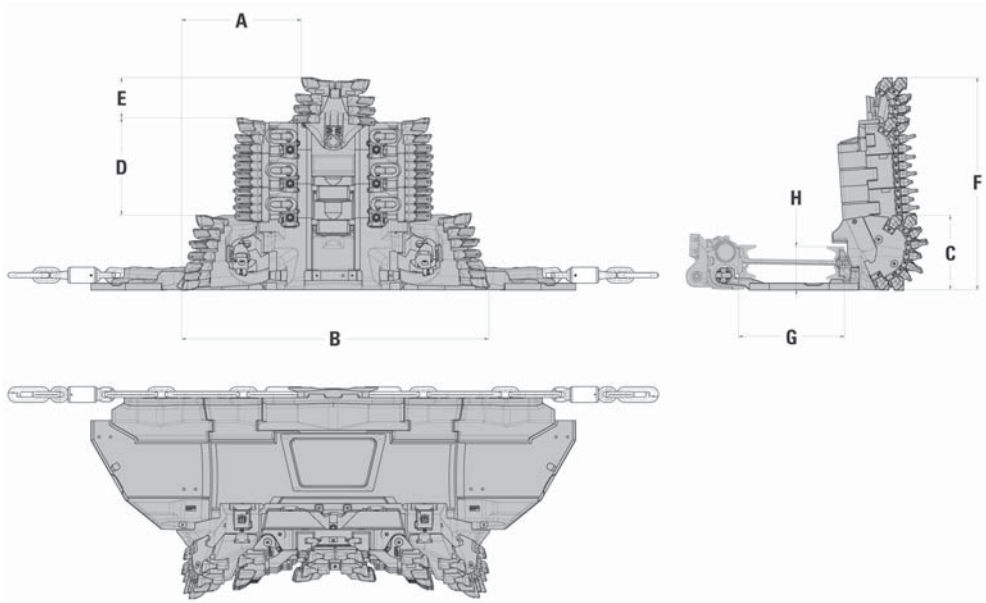

**Model**

**RHH800 — Plow Body Setup Option 4**

<b>A</b>	930 mm	3.05 ft
<b>B</b>	2384 mm	7.82 ft
<b>C</b>	579 mm	1.90 ft
<b>D</b>	759 mm	2.49 ft
<b>E</b>	312 mm	1.02 ft
<b>F</b>	1650 mm	5.41 ft
<b>G</b>	822 mm	2.70 ft
<b>H</b>	377 mm	1.11 ft

**Dimensions GH800 — Plow Body Setup Option 1 (All dimensions are approximate.)**

**Stageless Height Adjustment**  
Adjustable Range 260 mm (0.89 ft)  
10 Revolutions = 25 mm (0.08 ft) Pass

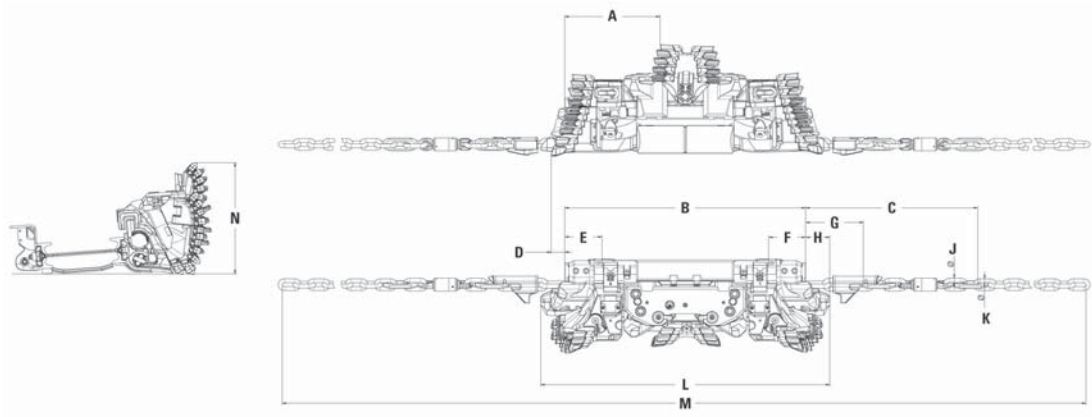

Model	GH800 — Plow Body Setup Option 1	
A	894 mm	2.93 ft
B	2261 mm	7.41 ft
C	1613 mm	5.29 ft
D	128 mm	0.41 ft
E	349 mm	1.14 ft
F	349 mm	1.14 ft
G	541 mm	1.77 ft
H	226 mm	0.74 ft
J	42 mm	0.14 ft
K	38 mm	0.24 ft
L	2712 mm	8.89 ft
M	14 529 mm	47.67 ft
N	1060 mm	3.47 ft



**Dimensions GH800 — Plow Body Setup Option 2 (All dimensions are approximate.)**

**Stageless Height Adjustment**  
**Adjustable Range 300 mm (0.98 ft)**  
**10 Revolutions = 25 mm (0.08 ft) Pass**

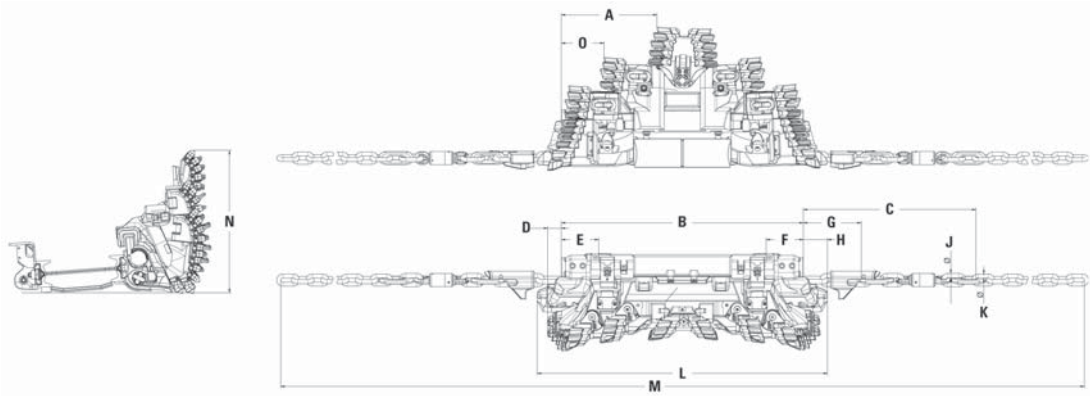

Model	GH800 — Plow Body Setup Option 2	
A	894 mm	2.93 ft
B	2261 mm	7.41 ft
C	1613 mm	5.29 ft
D	128 mm	0.41 ft
E	349 mm	1.14 ft
F	349 mm	1.14 ft
G	541 mm	1.77 ft
H	226 mm	0.74 ft
J	42 mm	0.14 ft
K	38 mm	0.24 ft
L	2712 mm	8.89 ft
M	14 529 mm	47.67 ft
N	1320 mm	4.33 ft
O	398 mm	1.31 ft

**Dimensions GH800 — Plow Body Setup Option 3 (All dimensions are approximate.)**

**Stageless Height Adjustment**  
Adjustable Range 300 mm (0.98 ft)  
10 Revolutions = 25 mm (0.08 ft) Pass

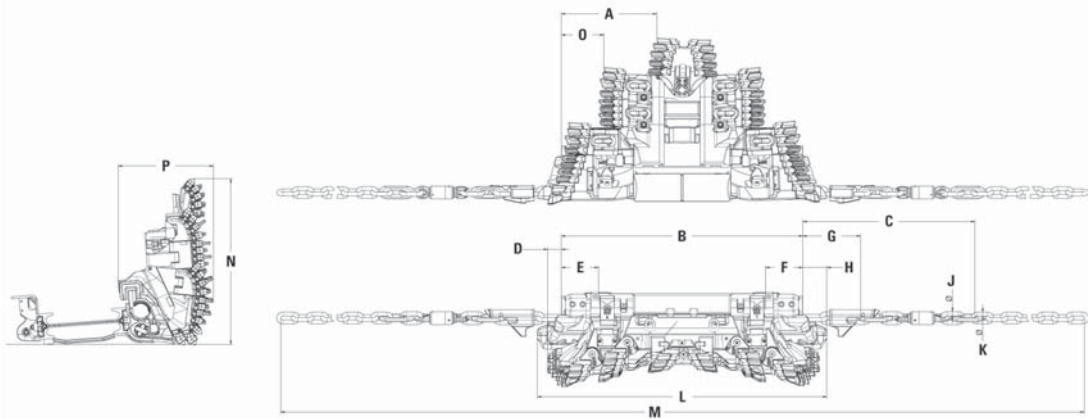

Model	GH800 — Plow Body Setup Option 3	
A	894 mm	2.93 ft
B	2261 mm	7.41 ft
C	1613 mm	5.29 ft
D	128 mm	0.41 ft
E	349 mm	1.14 ft
F	349 mm	1.14 ft
G	541 mm	1.77 ft
H	226 mm	0.74 ft
J	42 mm	0.14 ft
K	38 mm	0.24 ft
L	2712 mm	8.89 ft
M	14 529 mm	47.67 ft
N	1585 mm	5.20 ft
O	398 mm	1.31 ft
P	891 mm	2.92 ft

**Dimensions GH800 — Plow Body Setup Option 4 (All dimensions are approximate.)**

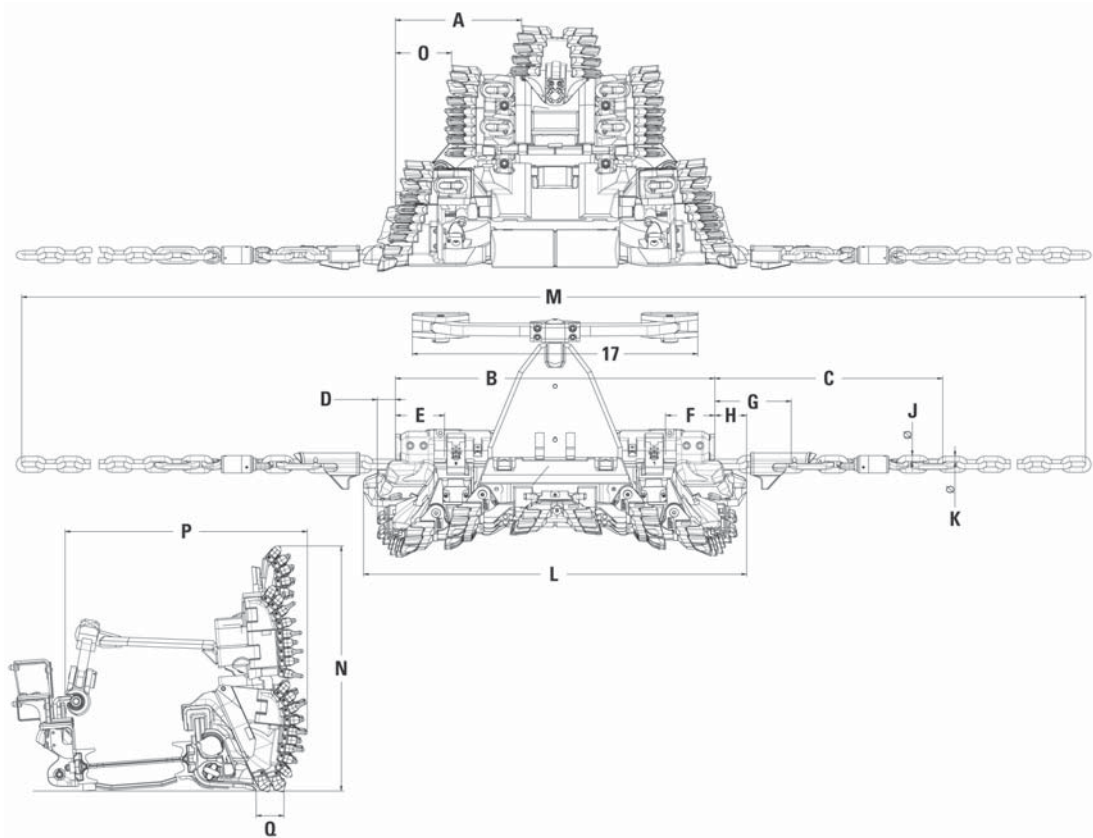

**Model**

**GH800 — Plow Body Setup Option 4**

<b>A</b>	894 mm	2.93 ft	<b>K</b>	38 mm	0.24 ft
<b>B</b>	2261 mm	7.41 ft	<b>L</b>	2712 mm	8.89 ft
<b>C</b>	1613 mm	5.29 ft	<b>M</b>	14 529 mm	47.67 ft
<b>D</b>	128 mm	0.41 ft	<b>N</b>	1735 mm	5.69 ft
<b>E</b>	349 mm	1.14 ft	<b>O</b>	398 mm	1.31 ft
<b>F</b>	349 mm	1.14 ft	<b>P</b>	1714 mm	5.62 ft
<b>G</b>	541 mm	1.77 ft	<b>Q</b>	196 mm	0.64 ft
<b>H</b>	226 mm	0.74 ft	<b>R</b>	2020 mm	6.62 ft
<b>J</b>	42 mm	0.14 ft			

Dimensions GH800 — Plow Body Setup Option 5 (All dimensions are approximate.)

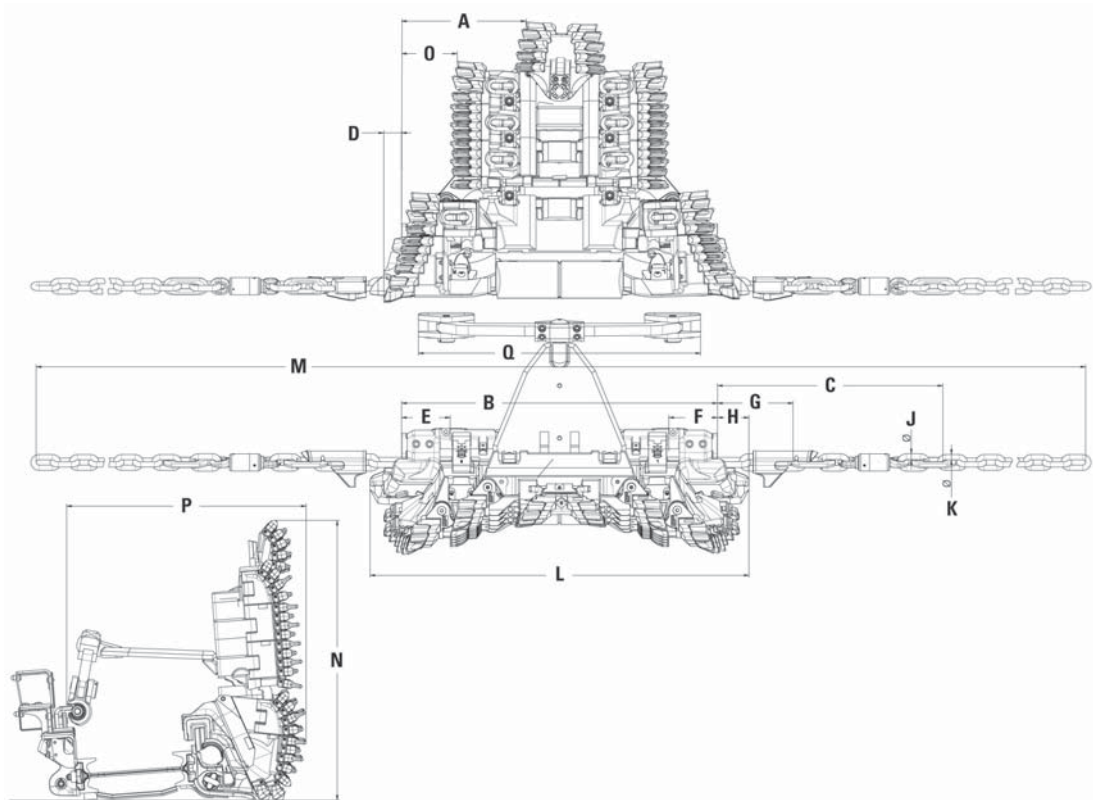

Model		GH800 — Plow Body Setup Option 5			
<b>A</b>	894 mm	2.93 ft	<b>J</b>	42 mm	0.14 ft
<b>B</b>	2261 mm	7.41 ft	<b>K</b>	38 mm	0.24 ft
<b>C</b>	1613 mm	5.29 ft	<b>L</b>	2712 mm	8.89 ft
<b>D</b>	128 mm	0.41 ft	<b>M</b>	14 529 mm	47.67 ft
<b>E</b>	348.5 mm	1.14 ft	<b>N</b>	2000 mm	6.56 ft
<b>F</b>	348.5 mm	1.14 ft	<b>O</b>	398 mm	1.31 ft
<b>G</b>	541 mm	1.77 ft	<b>P</b>	1714 mm	5.62 ft
<b>H</b>	225.5 mm	0.73 ft	<b>Q</b>	2020 mm	6.62 ft

**Dimensions GH800B — Plow Body Setup Option 1 (All dimensions are approximate.)**

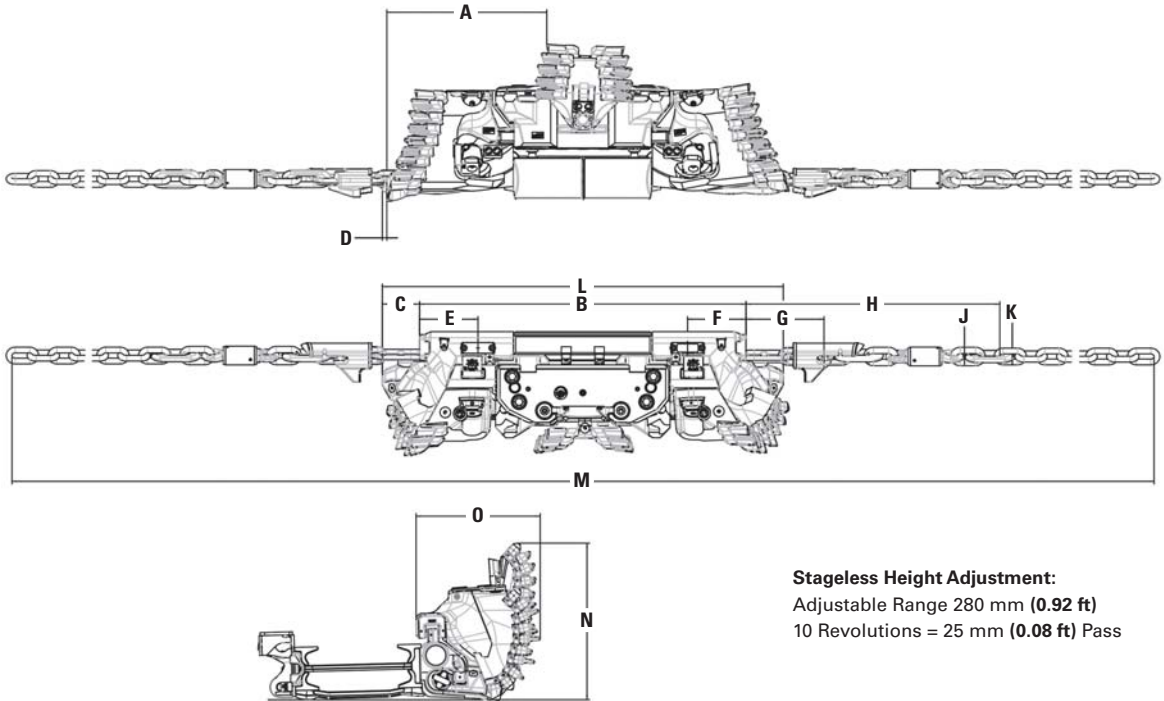

**Stageless Height Adjustment:**  
 Adjustable Range 280 mm (0.92 ft)  
 10 Revolutions = 25 mm (0.08 ft) Pass

**Model**

**GH800B — Plow Body Setup Option 1**

<b>A</b>	1051 mm	3.54 ft	<b>H</b>	1671 mm	5.48 ft
<b>B</b>	2146 mm	7.04 ft	<b>J</b>	42 mm	0.14 ft
<b>C</b>	245 mm	0.8 ft	<b>K</b>	38 mm	0.24 ft
<b>D</b>	30 mm	0.1 ft	<b>L</b>	2636 mm	8.65 ft
<b>E</b>	384 mm	1.26 ft	<b>M</b>	14 529 mm	47.67 ft
<b>F</b>	384 mm	1.26 ft	<b>N</b>	1030 mm	3.38 ft
<b>G</b>	515 mm	1.69 ft	<b>O</b>	816 mm	2.68 ft

**Dimensions GH800B — Plow Body Setup Option 2 (All dimensions are approximate.)**

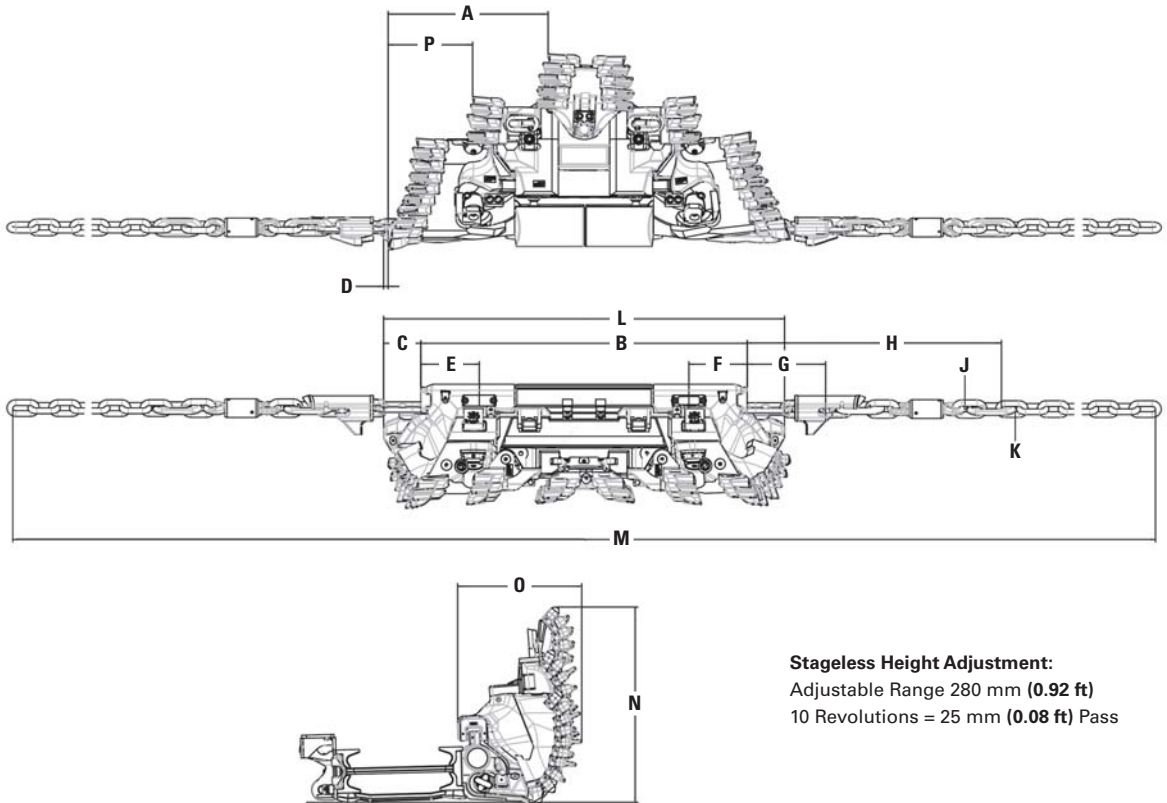

**Stageless Height Adjustment:**  
Adjustable Range 280 mm (0.92 ft)  
10 Revolutions = 25 mm (0.08 ft) Pass

**Model GH800B — Plow Body Setup Option 2**

<b>A</b>	1051 mm	3.54 ft	<b>J</b>	42 mm	0.14 ft
<b>B</b>	2146 mm	7.04 ft	<b>K</b>	38 mm	0.24 ft
<b>C</b>	245 mm	0.8 ft	<b>L</b>	2636 mm	8.65 ft
<b>D</b>	30 mm	0.1 ft	<b>M</b>	14 529 mm	47.67 ft
<b>E</b>	384 mm	1.26 ft	<b>N</b>	1285 mm	4.22 ft
<b>F</b>	384 mm	1.26 ft	<b>O</b>	816 mm	2.68 ft
<b>G</b>	515 mm	1.69 ft	<b>P</b>	555 mm	1.82 ft
<b>H</b>	1671 mm	5.48 ft			

**Dimensions GH800B — Plow Body Setup Option 3 (All dimensions are approximate.)**

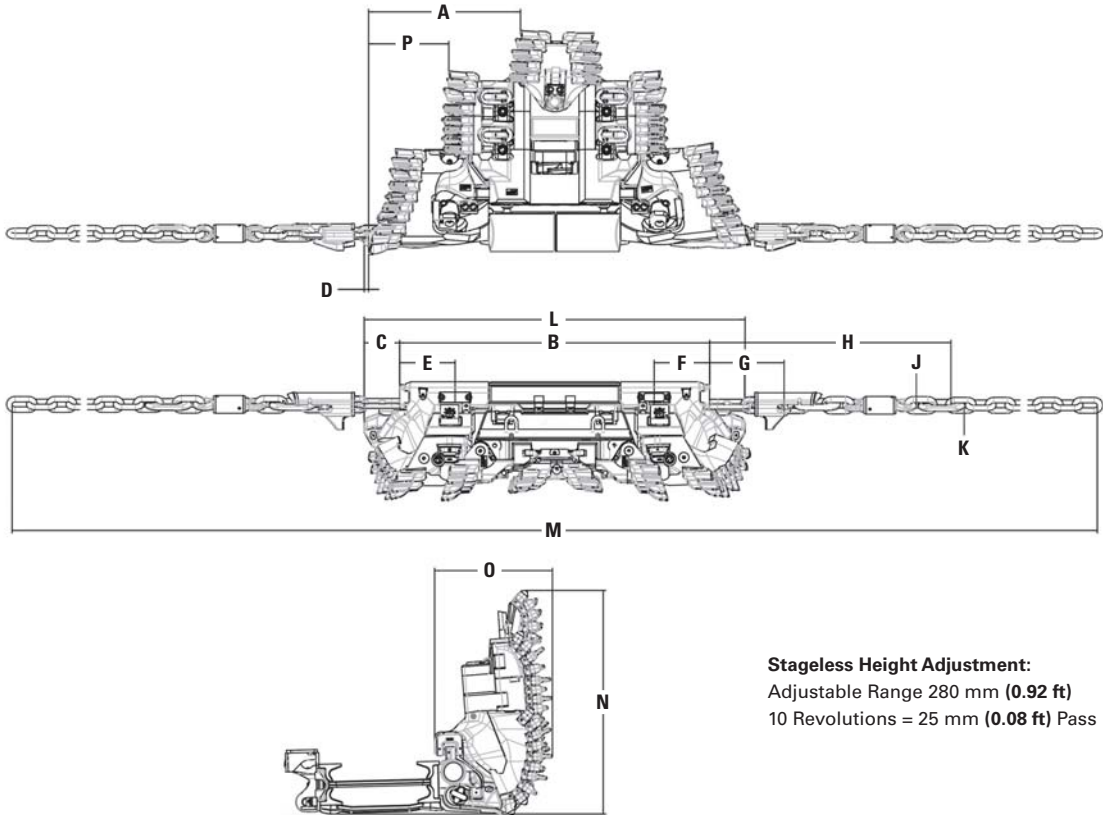

**Stageless Height Adjustment:**  
 Adjustable Range 280 mm (0.92 ft)  
 10 Revolutions = 25 mm (0.08 ft) Pass

**Model**

**GH800B — Plow Body Setup Option 3**

<b>A</b>	1051 mm	3.54 ft	<b>J</b>	42 mm	0.14 ft
<b>B</b>	2146 mm	7.04 ft	<b>K</b>	38 mm	0.24 ft
<b>C</b>	245 mm	0.8 ft	<b>L</b>	2636 mm	8.65 ft
<b>D</b>	30 mm	0.1 ft	<b>M</b>	14 529 mm	47.67 ft
<b>E</b>	384 mm	1.26 ft	<b>N</b>	1550 mm	5.09 ft
<b>F</b>	384 mm	1.26 ft	<b>O</b>	816 mm	2.68 ft
<b>G</b>	515 mm	1.69 ft	<b>P</b>	555 mm	1.82 ft
<b>H</b>	1671 mm	5.48 ft			

**Dimensions GH800B — Plow Body Setup Option 4 (All dimensions are approximate.)**

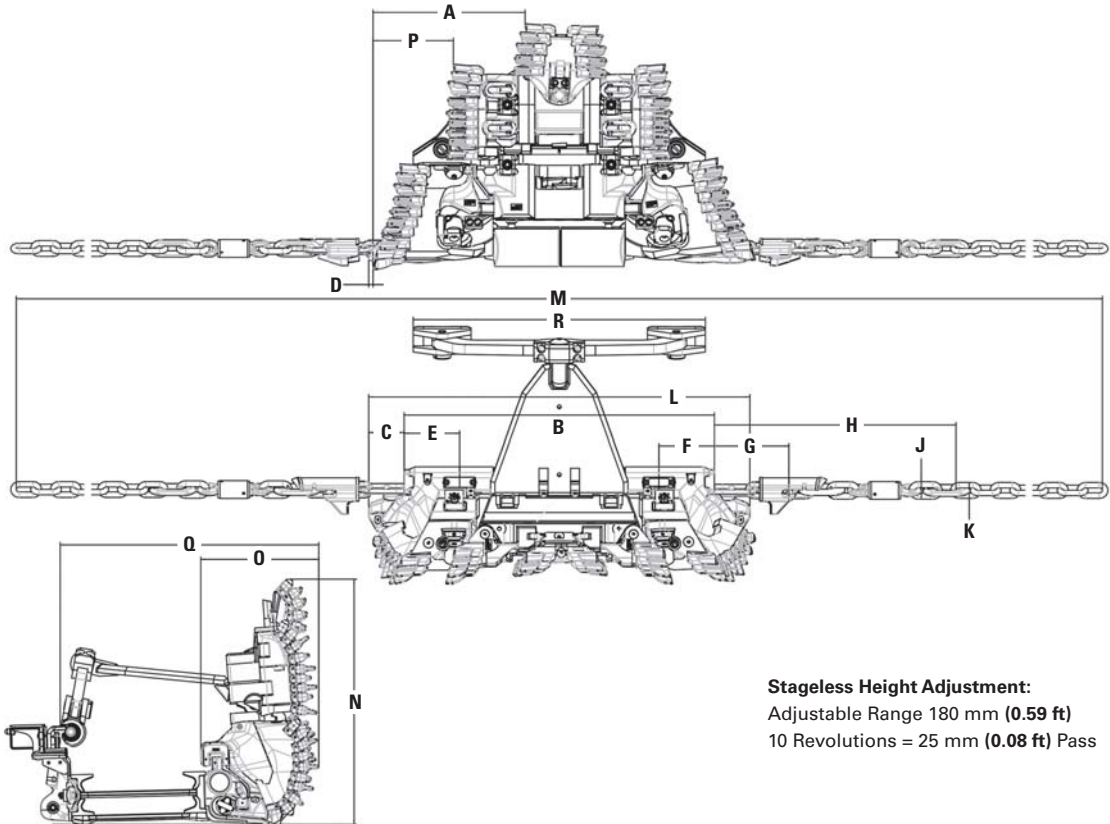

**Stageless Height Adjustment:**  
Adjustable Range 180 mm (0.59 ft)  
10 Revolutions = 25 mm (0.08 ft) Pass

**Model GH800B — Plow Body Setup Option 4**

<b>A</b>	1051 mm	3.54 ft	<b>K</b>	38 mm	0.24 ft
<b>B</b>	2146 mm	7.04 ft	<b>L</b>	2636 mm	8.65 ft
<b>C</b>	245 mm	0.8 ft	<b>M</b>	14 529 mm	47.67 ft
<b>D</b>	30 mm	0.1 ft	<b>N</b>	1700 mm	5.58 ft
<b>E</b>	384 mm	1.26 ft	<b>O</b>	816 mm	2.68 ft
<b>F</b>	384 mm	1.26 ft	<b>P</b>	555 mm	1.82 ft
<b>G</b>	515 mm	1.69 ft	<b>Q</b>	1788 mm	5.88 ft
<b>H</b>	1671 mm	5.48 ft	<b>R</b>	2020 mm	6.62 ft
<b>J</b>	42 mm	0.14 ft			



**Dimensions GH800B — Plow Body Setup Option 5 (All dimensions are approximate.)**

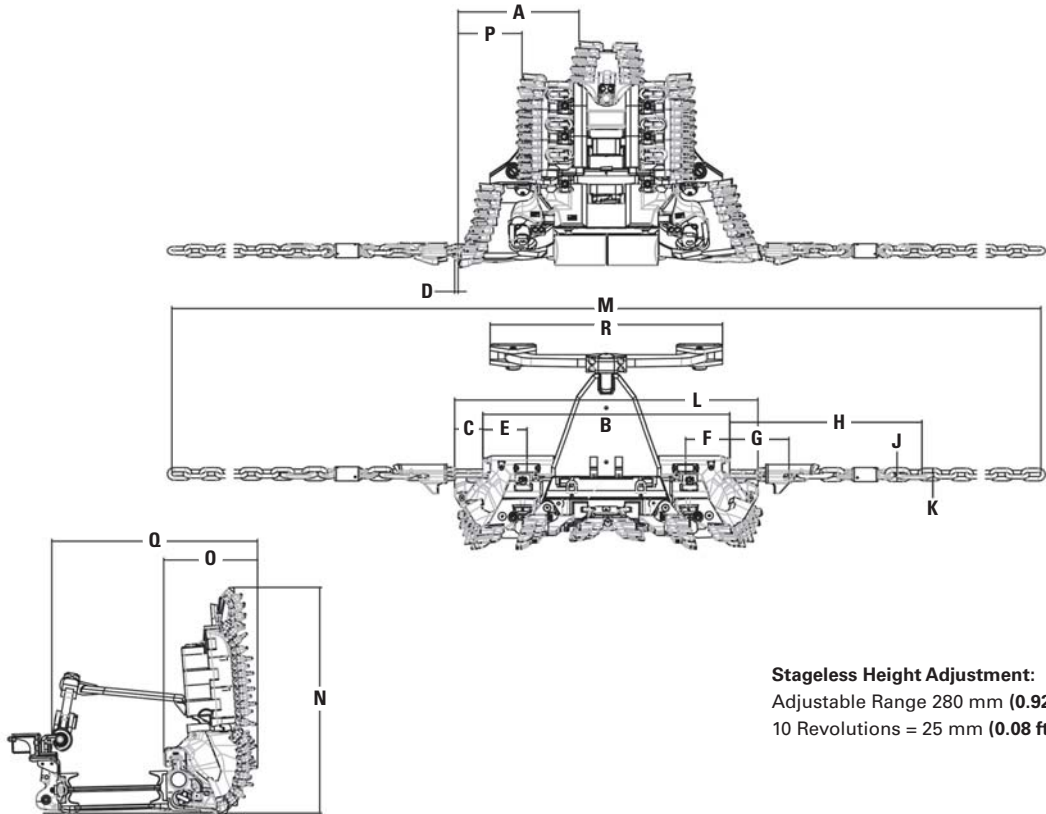

**Stageless Height Adjustment:**  
 Adjustable Range 280 mm (0.92 ft)  
 10 Revolutions = 25 mm (0.08 ft) Pass

**Model GH800B — Plow Body Setup Option 5**

<b>A</b>	1051 mm	3.54 ft	<b>K</b>	38 mm	0.24 ft
<b>B</b>	2146 mm	7.04 ft	<b>L</b>	2636 mm	8.65 ft
<b>C</b>	245 mm	0.8 ft	<b>M</b>	14 529 mm	47.67 ft
<b>D</b>	30 mm	0.1 ft	<b>N</b>	1965 mm	6.45 ft
<b>E</b>	384 mm	1.26 ft	<b>O</b>	816 mm	2.68 ft
<b>F</b>	384 mm	1.26 ft	<b>P</b>	555 mm	1.82 ft
<b>G</b>	515 mm	1.69 ft	<b>Q</b>	1788 mm	5.88 ft
<b>H</b>	1671 mm	5.48 ft	<b>R</b>	2020 mm	6.62 ft
<b>J</b>	42 mm	0.14 ft			

Dimensions GH1600 – Plow Body Setup Option 1 (All dimensions are approximate.)

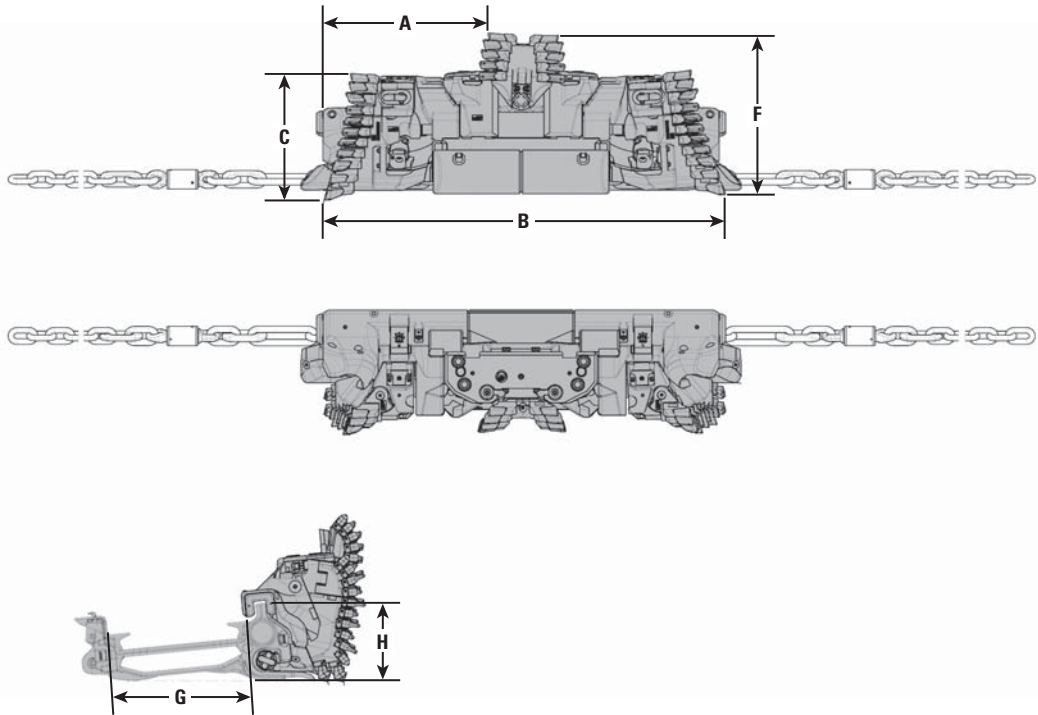

Model	GH1600 – Plow Body Setup Option 1	
A	1211 mm	3.97 ft
B	2969 mm	9.74 ft
C	931 mm	3.05 ft
D	—	—
E	—	—
F	1230 mm	4.04 ft
G	1032 mm	3.38 ft
H	578 mm	1.89 ft

**Dimensions GH1600 – Plow Body Setup Option 2 (All dimensions are approximate.)**

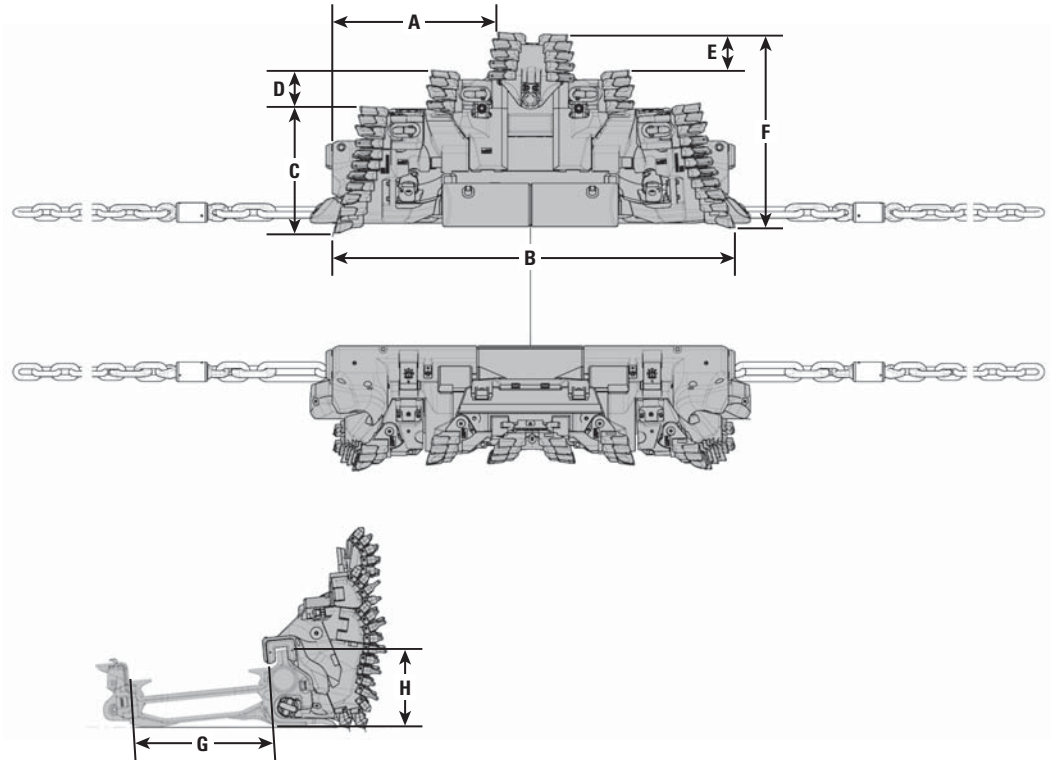

Model	GH1600 – Plow Body Setup Option 2	
A	1211 mm	3.97 ft
B	2969 mm	9.74 ft
C	931 mm	3.05 ft
D	264 mm	0.87 ft
E	285 mm	0.94 ft
F	1480 mm	4.86 ft
G	1032 mm	3.38 ft
H	578 mm	1.89 ft

**Dimensions GH1600 – Plow Body Setup Option 3 (All dimensions are approximate.)**

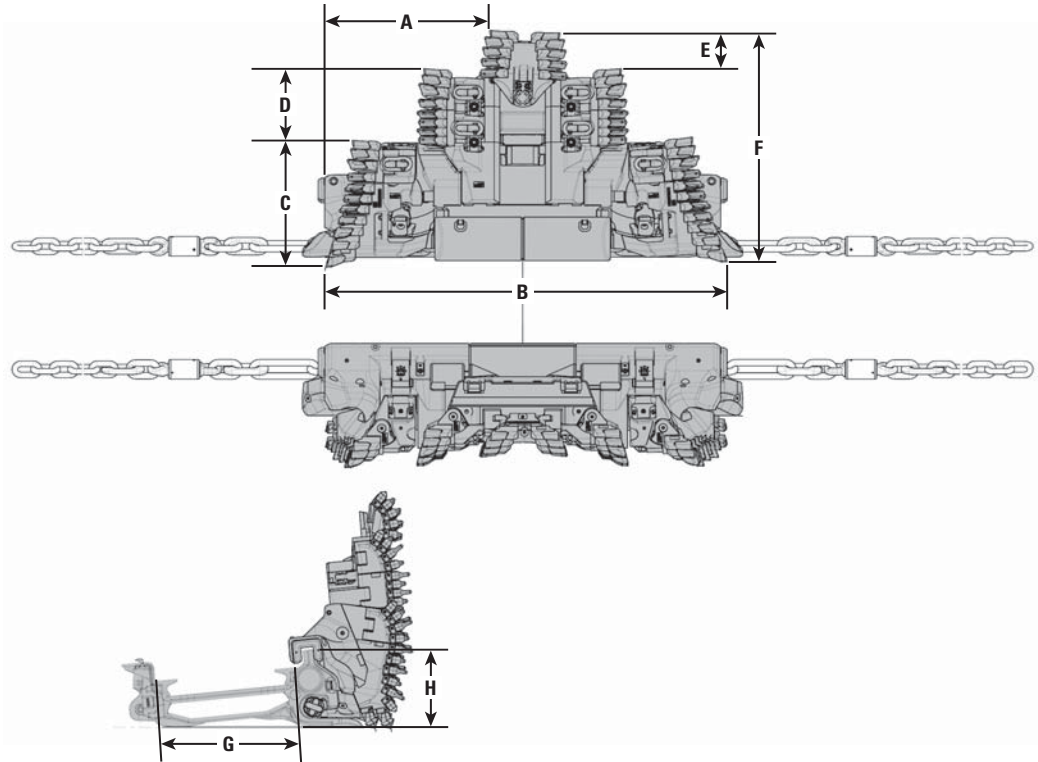

Model	GH1600 – Plow Body Setup Option 3	
A	1211 mm	3.97 ft
B	2969 mm	9.74 ft
C	931 mm	3.05 ft
D	529 mm	1.74 ft
E	285 mm	0.94 ft
F	1745 mm	5.73 ft
G	1132 mm	3.71 ft
H	578 mm	1.89 ft

**Dimensions GH1600 — Plow Body Setup Option 4 (All dimensions are approximate.)**

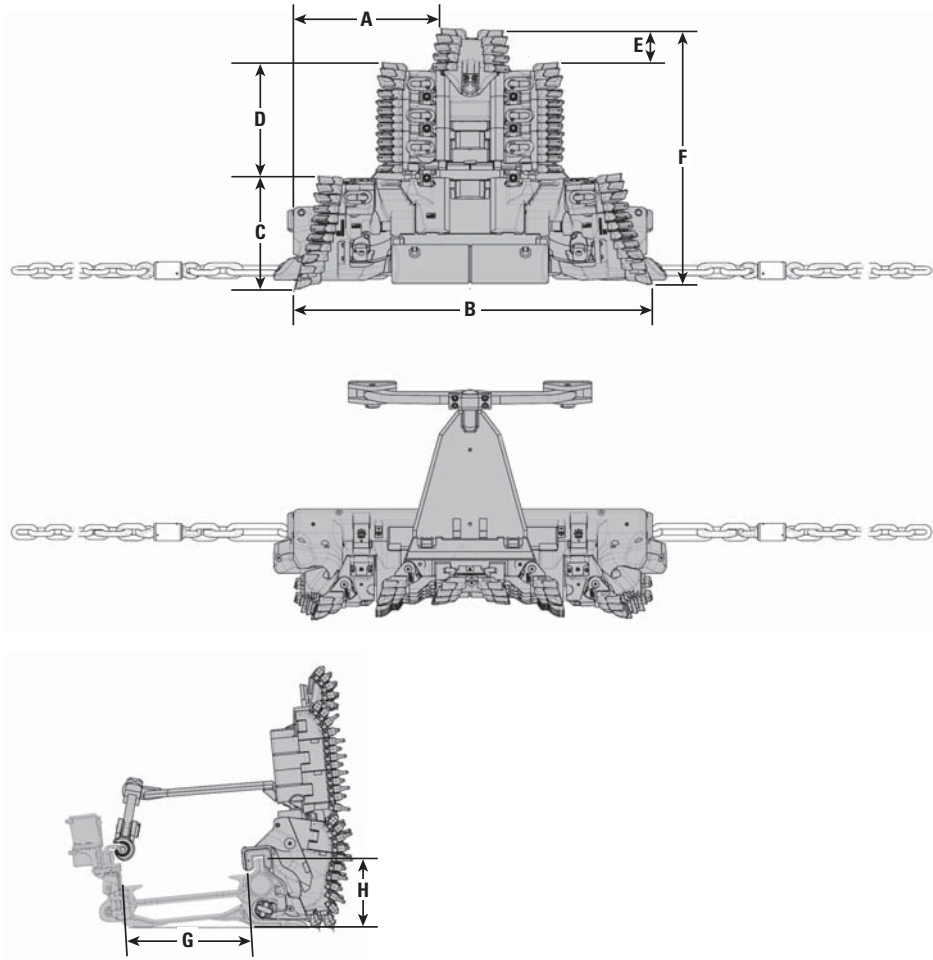

Model	GH1600 — Plow Body Setup Option 4	
A	1211 mm	3.97 ft
B	2969 mm	9.74 ft
C	931 mm	3.05 ft
D	944 mm	3.10 ft
E	285 mm	0.94 ft
F	2160 mm	7.09 ft
G	1132 mm	3.71 ft
H	578 mm	1.89 ft

**PMC-R**  
**Roof Support Control**



The intrinsically-safe Cat PMC-R control units are used on shearer or plow faces to provide medium to high level of longwall automation. Each Roof Support needs to be equipped with one PMC-R control unit, a solenoid driver to operate the in-shield hydraulic functions and a set of peripheral components, like sensors for pressures and shield advance.

The PMC-R can control and display all functions of a shield and is simultaneously the interface between operator and machine (HMI).

The PMC-R system can control all individual shield functions based on a reliable network. As an interactive system, it allows the user to execute single shield functions as well as automatic functions. Important process values are continuously displayed as feedback for the operator.

**Features PMC-R Control Unit**

- Robust design (OS4/OS8 plugs, hose cables, stainless steel housing)
- IP 68 rating (48 h under @ 1 m [3.28 ft] under water)
- Separate Quick Stop and Local Lockout switches
- HMI with 30 multi feedback keys (sound, pressure point, led light)
- Two (2) line LCD graphical display
- Multi language support
- Maintainability (brass bar mounting, screws from the front)
- Integrated infrared
- Can control up to three (3) separate solenoid driver boards

**Front View of the PMC-R**

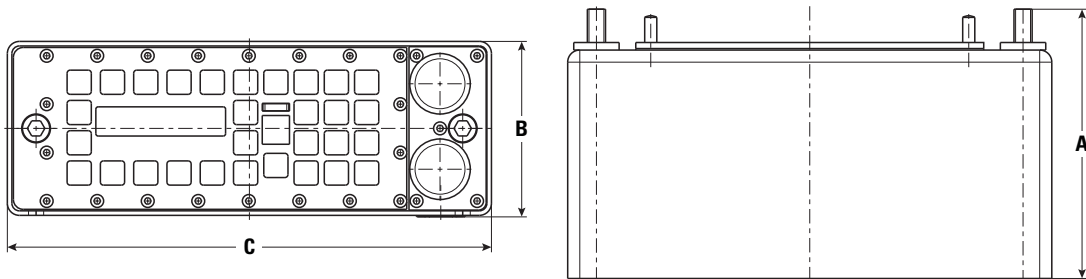

**Dimensions (All dimensions are approximate.)**

<b>A</b> Width	178 mm	<b>7.01"</b>
<b>B</b> Height	116 mm	<b>4.57"</b>
<b>C</b> Length	320 mm	<b>12.60"</b>

Rear Side View of the PMC-R

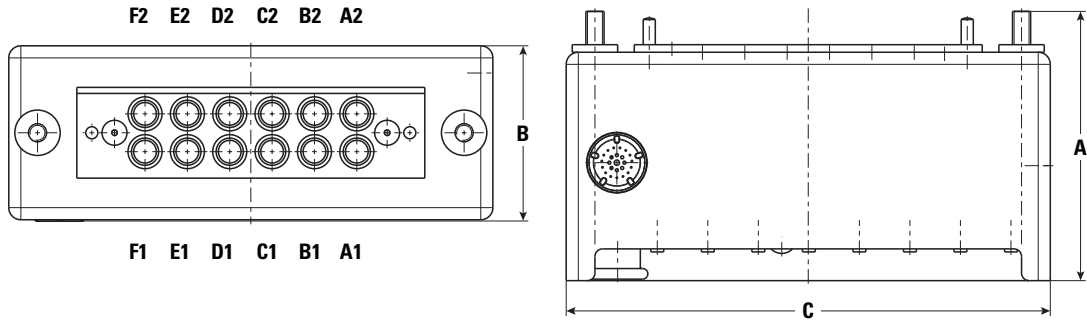

Dimensions (All dimensions are approximate.)

<b>A</b> Width	178 mm	7.01"
<b>B</b> Height	116 mm	4.57"
<b>C</b> Length	320 mm	12.60"

Exemplarily System Layout of a PMC-R System (Shearer Face)

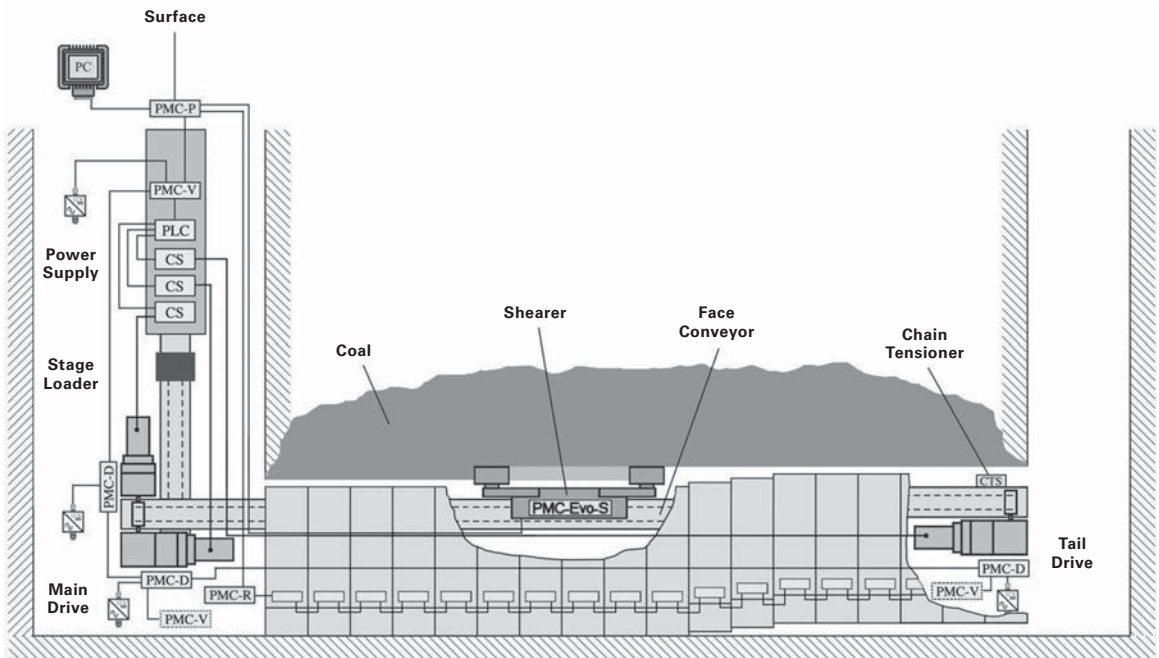

Together with the following peripheral equipment the PMC-R controller forms an individually per customer order designed control system for Longwall automation.

- Solenoid Driver Board (minimum one per Roof Support)
- Pressure Sensor
- Reed Rod
- Proximity Switch
- IR Transmitter and Sensor
- LED Warning Light
- IS Power Supply
- Diverse Data Coupler
- 3D-Tilt Sensor and 3D-Tilt Monitor
- Double Solenoid Valve

Such a PMC-R control system consists typically of more than a hundred similar subsystems set up by a PMC-R controller, solenoid driver, sensors, and valves per roof support and one time used hardware at the gate ends as server controllers, IPC, communication modules, chain tensioner, etc.

#### **Main Features PMC-R Control System**

- “Distributed Intelligence in each shield”
- Wide range of sensors and multiple solenoid drivers
- Easy diagnosis through communication between PMC-R controls
- Various auto sequences
- Automated conveyor push modes
- Conveyor pullback functions
- Automated water spray functions

- Outrigger steering for conveyor steering (mostly plow faces)
- Automation of:
  - Block anchorage
  - Flipper
  - Sliding canopy
  - Gap shield
  - Several steering cylinder automation modes dependent on roof conditions

Via a decentralized visualization and control unit at the face and/or the surface supports MineStar capabilities, especially HEALTH for Longwall.

The entire PMC-R system provides different global certifications:

- Europe: ATEX
- U.S.: MSHA
- Russia: EAC/Ex
- Australia: IECEx, ANZEx
- China: MA
- More certifications on demand

#### **Solenoid Driver Module**

The PMC-R solenoid driver module is placed at a distance from the PMC-R in accordance with the modular concept. The solenoid driver module can activate up to 22 valve functions, additional lights and sound modules or relays. As well, additional sensors could be read in by the solenoid driver module.



Solenoid Driver Module

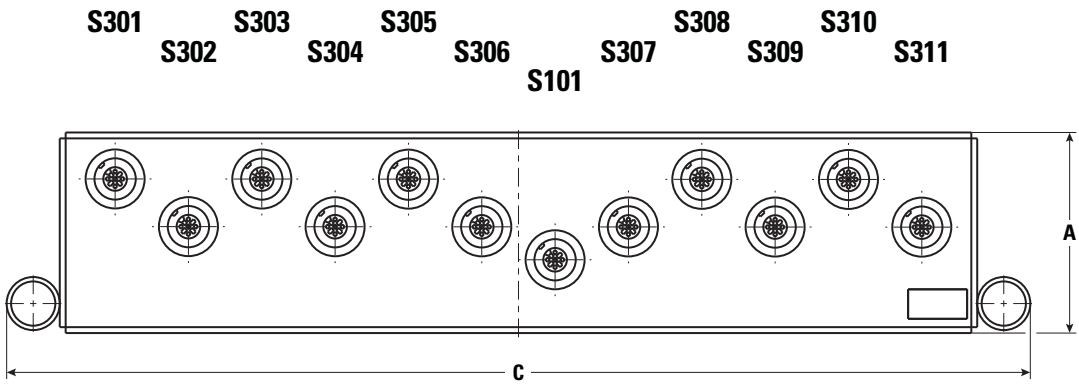
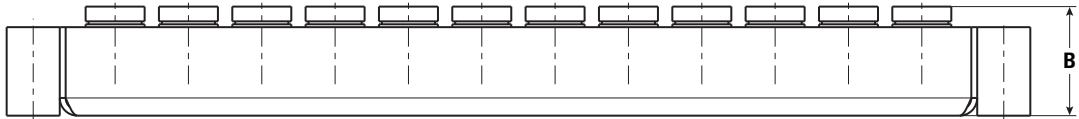

**Dimensions (All dimensions are approximate.)**

<b>A</b>	Width	68 mm	2.68"
<b>B</b>	Height	37 mm	1.46"
<b>C</b>	Length	347 mm	13.66"

## PMC-D and PMC-V

### Drive Control Unit and HMI (Human Machine Interface)

The intrinsically-safe PMC-D control is used on shearer or plow faces to provide high level AFC (armed face conveyor) and plow automation. Each Drive unit needs to be equipped with one PMC-D control unit and equivalent I/O to operate the CST drives or UEL gearbox functions.

The PMC-V provides in such a system the HMI to interact with the PMC-D controls to operate manual mode, visualize and change parameters and show actual process values. Within a PMC-D system minimum one and typically up to 3 PMC-Vs are in equal operation.

The PMC-D system can control extremely sensitive the speed and torque of highly powered AFC CST drive. Using Profibus network all PMC-Ds and PMC-Vs in a system could exchange process data over long distances with high frequency.

### Attributes of PMC-D/PMC-D20 Control Unit

- Robust stainless steel design
- Highly reliable OS37 plug technology for complete gearbox control
- SKK24 hose cables for bus system and additional I/O connection
- IP 68 rating (48 h under @ 1 m [3.28 ft] under water)
- HMI with 24 multi feedback keys (pressure point, led light)
- 63.5 mm (2½") graphical monochrome display
- Multi language support
- Maintainability (brass bar mounting)
- Optional eight (8) additional ports for acceleration sensors (PMC-D20)

## PMC-D

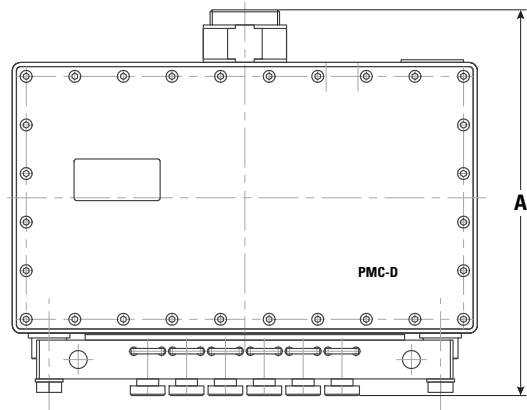
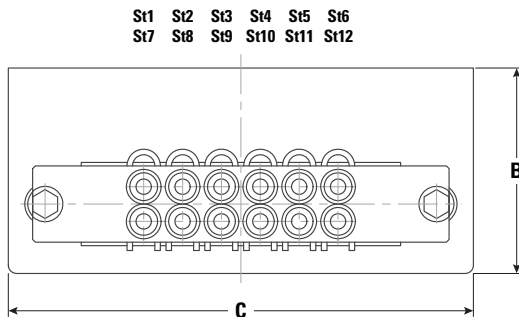

### PMC-D Dimensions and Plug Assignments (All dimensions are approximate.)

<b>A</b> Width	278 mm	10.94"
<b>B</b> Height	148 mm	5.83"
<b>C</b> Length	335 mm	13.19"

PMC-D20

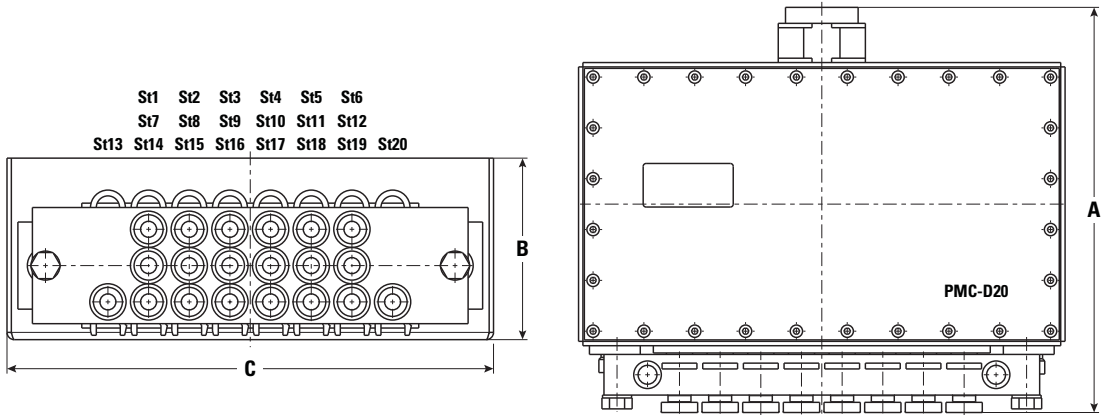

**PMC-D20 Dimensions and Plug Assignments (All dimensions are approximate.)**

<b>A</b> Width	279 mm	10.98"
<b>B</b> Height	125 mm	4.92"
<b>C</b> Length	335 mm	13.19"

PMC-V

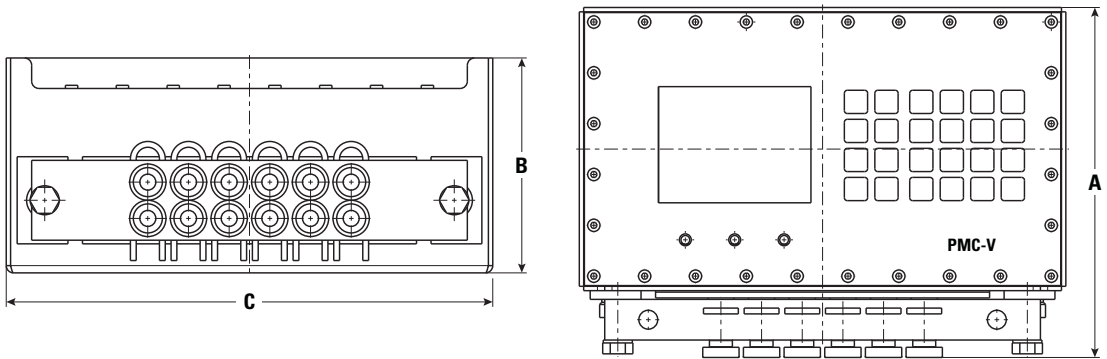

**PMC-V Dimensions (All dimensions are approximate.)**

<b>A</b> Width	241 mm	9.49"
<b>B</b> Height	148 mm	5.83"
<b>C</b> Length	335 mm	13.19"

Exemplarily System Layout of a PMC-D System (Plow Face)

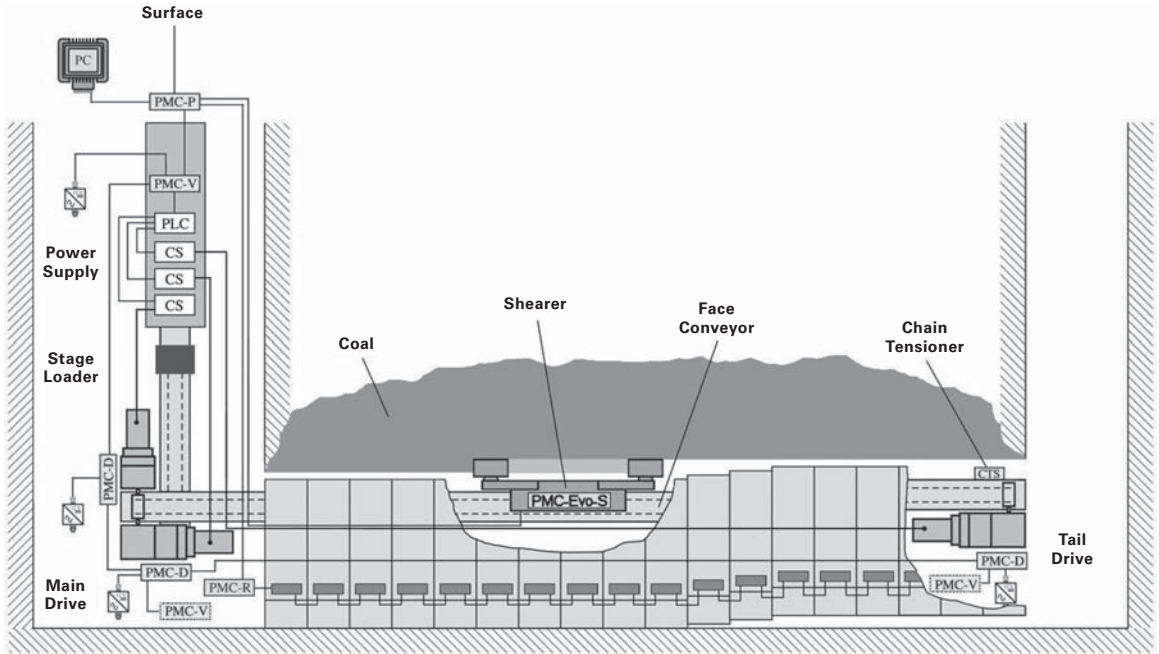

**Main Features of the PMC-D Drive Control System**

- “Distributed controller Intelligence per drive”
- Synchronized heavy load start up
- Soft startup
- Load sharing between conveyor drives
- Overload protection
- Motor braking feature
- Further used in plow operations:
  - Precise position detection
  - Overload protection

**Additional Features**

- Usage of PMC-D for chain tensioning of AFC (front and rear conveyor) and BSL
- In conjunction with Slacktronik® direct BLS chain slack control and relating chain tensioning
- Usage of PMC-D for high accurate plow position control and monitoring
- Support VFD controlled drive applications
- Optional integration of “HEALTH for Longwall Vibration Analysis” function with PMC-D20 control unit:
  - Acceleration sensor interface for eight (8) sensors
  - Integrated communication for vibration analysis

The entire PMC-D system provides different global certifications:

- Europe: ATEX
- U.S.: MSHA
- Russia: EAC/Ex
- Australia: IECEX, ANZEx
- China: MA
- More certifications on demand

Via a decentralized visualization and control unit at the face and/or the surface supports MineStar capabilities, especially HEALTH for Longwall.

**HEALTH for Longwall Vibration Analysis**

HEALTH for Longwall Vibration Analysis (former VibraGuard) provides vibration monitoring functionality for longterm health monitoring of the following longwall related equipment:

- CST gearbox and relating motor
- UEL gearbox and relating motor
- Stage loader gearbox and relating motor
- Crusher and relating motor
- Shearer haulage and ranging arm gearboxes
- Water/HFA pump station

## MCU2

### Main Control Unit

#### Application

- Visualization of all longwall data underground at gate end
- Change and control parameter from gate end
- Analysis of longwall system operation and situation
- Provide relevant process and HEALTH data to surface mine control room

#### Features

- Comprehensive software suite (HEALTH for Longwall) serving application software for Roof Support, AFC, Shearer and Plow
- Multi-language support:
  - English, German, Russian, Polish, Czech, Spanish, Chinese
- Robust IPC architecture for reliable operation in hazardous areas
- IS external keyboard with mouse function
- Robust design for sudden Methane face wide power off

### Technical Data

#### Dimensions and Weight

Weight (approximate)	200 kg (441 lb)
Dimensions (approximate):	
Low support cabinet	630 × 945 × 450 mm (24.8 × 37.2 × 17.7 in)
High support cabinet	630 × 1145 × 450 mm (24.8 × 45.1 × 17.7 in)

#### Certifications and Identification

Certification	ATEX (within system: MA and GHOST)
Type of protection	I M2 EEx ib I
Temperature range	−20° C to +60° C (−4° F to +140° F)

#### Electrical Power Supply

- Power supply of the explosion-proof part, 110-240V AC
- Power supply of the intrinsically safe part, 12V DC, maximum 1.5A
- Non-intrinsically safe USB interface

#### Components

Processor	Intel i7 4 . 2.1 GHz
RAM memory	4 GB
Data memory	2 × 120 GB SSD
Hard drive	1 TB 6.4 cm (2.5 in)
Display	48.3 cm (19 in)
Resolution	1280:1024
Operating system	Windows 7
Input equipment keyboard with integrated mouse	

#### Intrinsically Safe Interfaces

- COM 1 BIDI SKK24
- COM 2 BIDI SKK24
- COM 3 BIDI SKK24
- COM 4 BIDI SKK24
- Ethernet via fiber-optic cable 9 μm

Drawings

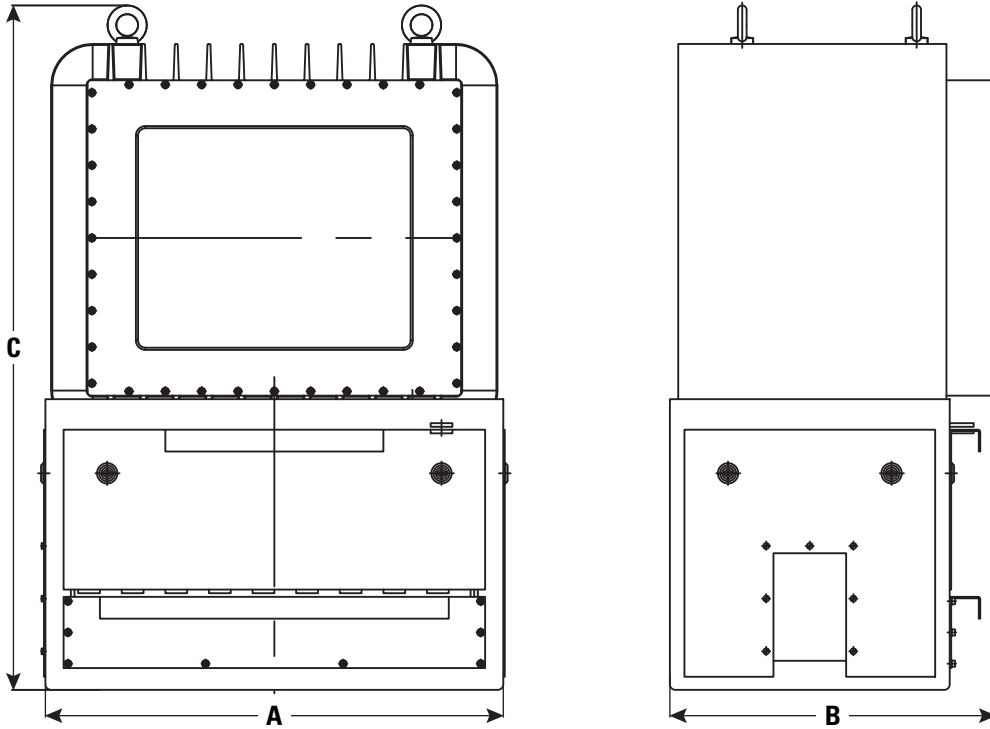

**MCU2 Dimensions (All dimensions are approximate.)**

<b>A</b>	Width	630 mm	24.80"
<b>B</b>	Height	450 mm	17.72"
<b>C</b>	Length	945 mm	37.20"

## ROOF SUPPORT CARRIERS

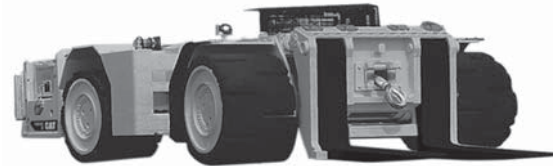
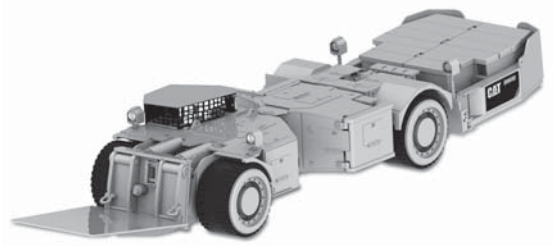

### Features

Caterpillar leads the industry in offering customers the most comprehensive line of roof support carriers.

- Capacities from 20 tonnes to 80 tonnes (22 tons to 88 tons) — most often without the need to disassemble large components.
- Length and widths for a variety of entry constraints.
- Safety features that include operators canopy and cab protection, diesel control system, ground level battery access, emergency stops, spring-applied, hydraulic released brakes and optional canopy guarding.
- Diesel and battery powered options.
- Versatile fifth-wheel towing capability with the SH150 trailer.
- Front end work tool options.



MODEL	SH640		SH640B	
	3126		C7 ACERT*	
Engine Model				
Engine Power — Gross	171.5 kW	<b>230 hp</b>	171.5 kW	<b>230 hp</b>
Engine Power — Net	160 kW	<b>216 hp</b>	160 kW	<b>216 hp</b>
Tire Size	<b>55 x 22 Solid</b>		<b>55 x 22 Solid</b>	
Nominal Payload Capacity — Trimming	40 000 kg	<b>88,160 lb</b>	40 000 kg	<b>88,160 lb</b>
Machine Operating Weight, Forks Fitted	39 590 kg	<b>87,281 lb</b>	40 800 kg	<b>89,950 lb</b>
Length — Overall	9610 mm	<b>378.3"</b>	9610 mm	<b>378.3"</b>
— Wheelbase	3600 mm	<b>141.7"</b>	3600 mm	<b>141.7"</b>
Width — Overall	2600 mm	<b>102.4"</b>	2600 mm	<b>102.4"</b>
— Over Tires	2597 mm	<b>102.2"</b>	2597 mm	<b>102.2"</b>
Height — Lift Height to Top of Fork Tines	935 mm	<b>36.8"</b>	935 mm	<b>36.8"</b>
— Body	1610 mm	<b>63.4"</b>	1610 mm	<b>63.4"</b>
— Top of Canopy Adjustable High (loaded)	2030 mm	<b>80"</b>	2030 mm	<b>80"</b>
— Top of Canopy Adjustable Mid (loaded)		<b>N/A</b>		<b>N/A</b>
— Top of Canopy Adjustable Low (loaded)	1970 mm	<b>77.6"</b>	1970 mm	<b>77.6"</b>
— Ground Clearance (loaded)	360 mm	<b>14.1"</b>	360 mm	<b>14.1"</b>
Turning Radius — Outer with Forks	6510 mm	<b>256.8"</b>	6510 mm	<b>256.8"</b>
— Inner	3400 mm	<b>133.9"</b>	3400 mm	<b>133.9"</b>
Angle — Articulation		<b>±42°</b>		<b>±42°</b>
— Rear Axle Oscillation		<b>±7°</b>		<b>±7°</b>
— Maximum Fork Tilt Forward		<b>23°</b>		<b>23°</b>
— Maximum Fork Tilt Back		<b>13°</b>		<b>13°</b>
Hydraulic Cycle Time:				
Raise		<b>9 Sec.</b>		<b>10 Sec.</b>
Lower		<b>8 Sec.</b>		<b>8 Sec.</b>
Crowded Forward to Back		<b>15 Sec.</b>		<b>16 Sec.</b>
Travel Speeds:	<b>km/h</b>	<b>mph</b>	<b>km/h</b>	<b>mph</b>
Forward — 1st	3.3	<b>2.1</b>	2.9	<b>1.8</b>
— 2nd	6.3	<b>3.9</b>	6.1	<b>3.8</b>
— 3rd	10.6	<b>6.6</b>	10.5	<b>6.5</b>
— 4th	16.5	<b>10.3</b>	18.1	<b>11.3</b>
Reverse — 1st	3.3	<b>2.1</b>	2.9	<b>1.8</b>
— 2nd	6.3	<b>3.9</b>	6.1	<b>3.8</b>
— 3rd	10.6	<b>6.6</b>	10.5	<b>6.5</b>
— 4th	16.5	<b>10.3</b>	18.1	<b>11.3</b>
Tilt Force SAE	73 500 kg	<b>161,994 lb</b>	73 500 kg	<b>161,994 lb</b>
Lift Force SAE	42 700 kg	<b>94,111 lb</b>	42 700 kg	<b>94,111 lb</b>
Refill Capacity:				
Fuel	350 L	<b>92.5 U.S. gal</b>	350 L	<b>92.5 U.S. gal</b>
Hydraulic	450 L	<b>118.9 U.S. gal</b>	450 L	<b>118.9 U.S. gal</b>
Engine Crankcase with Filter	25 L	<b>6.6 U.S. gal</b>	25 L	<b>6.6 U.S. gal</b>
Transmission	40 L	<b>10.6 U.S. gal</b>	40 L	<b>10.6 U.S. gal</b>
Axle (each)	44.6 L	<b>11.8 U.S. gal</b>	44.6 L	<b>11.8 U.S. gal</b>
Drop Box		<b>N/A</b>	8 L	<b>2.1 U.S. gal</b>
Exhaust Conditioner/Water	450 L	<b>118.9 U.S. gal</b>	450 L	<b>118.9 U.S. gal</b>
Cooling System	72 L	<b>19 U.S. gal</b>	72 L	<b>19 U.S. gal</b>

\*The 3126 meets U.S. EPA Tier 1, EU Stage I equivalent emission standards from the factory. The C7 ACERT engine meets U.S. EPA Tier 3, EU Stage IIIA, Japan 2006 (Tier 3) equivalent emission standards from the factory.

N/A = Not Available.

MODEL	SH660		SH660B	
	3126		C7 ACERT*	
Engine Model				
Engine Power — Gross	171.5 kW	<b>230 hp</b>	171.5 kW	<b>230 hp</b>
Engine Power — Net	160 kW	<b>216 hp</b>	160 kW	<b>216 hp</b>
Tire Size	<b>54 x 28 Solid</b>		<b>54 x 28 Solid</b>	
Nominal Payload Capacity — Trimming	60 000 kg	<b>132,240 lb</b>	60 000 kg	<b>132,240 lb</b>
Machine Operating Weight, Forks Fitted	59 200 kg	<b>130,476 lb</b>	59 200 kg	<b>130,476 lb</b>
Length — Overall	9940 mm	<b>391.2"</b>	9940 mm	<b>391.2"</b>
— Wheelbase	3620 mm	<b>142.5"</b>	3620 mm	<b>142.5"</b>
Width — Overall	3130 mm	<b>129.1"</b>	3130 mm	<b>129.1"</b>
— Over Tires	3100 mm	<b>122"</b>	3100 mm	<b>122"</b>
Height — Lift Height to Top of Fork Tines	670 mm	<b>26.4"</b>	670 mm	<b>26.4"</b>
— Body	1670 mm	<b>65.7"</b>	1670 mm	<b>65.7"</b>
— Top of Canopy Adjustable High (loaded)	2170 mm	<b>85.4"</b>	2170 mm	<b>85.4"</b>
— Top of Canopy Adjustable Mid (loaded)	2050 mm	<b>80.7"</b>	2050 mm	<b>80.7"</b>
— Top of Canopy Adjustable Low (loaded)	1980 mm	<b>78"</b>	1980 mm	<b>78"</b>
— Ground Clearance (loaded)	340 mm	<b>13.4"</b>	340 mm	<b>13.4"</b>
Turning Radius — Outer with Forks	6740 mm	<b>265.4"</b>	6740 mm	<b>265.4"</b>
— Inner	3120 mm	<b>122.8"</b>	3120 mm	<b>122.8"</b>
Angle — Articulation		<b>±42°</b>		<b>±42°</b>
— Rear Axle Oscillation		<b>±7°</b>		<b>±7°</b>
— Maximum Fork Tilt Forward		<b>27°</b>		<b>27°</b>
— Maximum Fork Tilt Back		<b>16°</b>		<b>16°</b>
Hydraulic Cycle Time:				
Raise		<b>6 Sec.</b>		<b>8 Sec.</b>
Lower		<b>5 Sec.</b>		<b>7 Sec.</b>
Crowded Forward to Back		<b>10 Sec.</b>		<b>12 Sec.</b>
Travel Speeds:	<b>km/h</b>	<b>mph</b>	<b>km/h</b>	<b>mph</b>
Forward — 1st	3.2	<b>2.0</b>	2.6	<b>1.6</b>
— 2nd	7.4	<b>4.6</b>	6.3	<b>3.9</b>
— 3rd	12.5	<b>7.8</b>	11.1	<b>6.9</b>
— 4th	20.5	<b>12.7</b>	19.5	<b>12.1</b>
Reverse — 1st	3.2	<b>2.0</b>	2.6	<b>1.6</b>
— 2nd	7.4	<b>4.6</b>	6.3	<b>3.9</b>
— 3rd	12.5	<b>7.8</b>	11.1	<b>6.9</b>
— 4th	20.5	<b>12.7</b>	19.5	<b>12.1</b>
Tilt Force SAE	102 700 kg	<b>226,350 lb</b>	102 700 kg	<b>226,350 lb</b>
Lift Force SAE	62 700 kg	<b>138,190 lb</b>	62 700 kg	<b>138,190 lb</b>
Refill Capacity:				
Fuel	370 L	<b>97.7 U.S. gal</b>	370 L	<b>97.7 U.S. gal</b>
Hydraulic	510 L	<b>134.7 U.S. gal</b>	510 L	<b>134.7 U.S. gal</b>
Engine Crankcase with Filter	25 L	<b>6.6 U.S. gal</b>	25 L	<b>6.6 U.S. gal</b>
Transmission	40 L	<b>10.6 U.S. gal</b>	40 L	<b>10.6 U.S. gal</b>
Axle (each)	69.5 L	<b>18.4 U.S. gal</b>	59.5 L	<b>18.4 U.S. gal</b>
Drop Box		<b>N/A</b>	8 L	<b>2.1 U.S. gal</b>
Exhaust Conditioner/Water	450 L	<b>118.9 U.S. gal</b>	450 L	<b>118.9 U.S. gal</b>
Cooling System	72 L	<b>19 U.S. gal</b>	72 L	<b>19 U.S. gal</b>

\*The 3126 meets U.S. EPA Tier 1, EU Stage I equivalent emission standards from the factory. The C7 ACERT engine meets U.S. EPA Tier 3, EU Stage IIIA, Japan 2006 (Tier 3) equivalent emission standards from the factory.

N/A = Not Available.

Model	SH620		SH630	
Lift and Carry Capacity (Tire Dependent)	19.9 tonnes*	<b>22 tons*</b>	32.6 tonnes**	<b>36 tons**</b>
Machine Weight:				
less Battery	21 047 kg	<b>46,400 lb</b>	22 453 kg	<b>49,500 lb</b>
with 64SS125-21 Battery	28 123 kg	<b>62,000 lb</b>	—	—
with 64-125-25 Battery			33 566 kg	<b>74,000 lb</b>
with 64-125-25 Battery and Rear Ballast			36 287 kg	<b>80,000 lb</b>
Drive Train Tram Motors		<b>2</b>		<b>2</b>
Drive Train Tram Motor Power (each)	37.3 kW	<b>50 hp</b>	37.3 kW	<b>50 hp</b>
Tram Speed	8 km/h	<b>5 mph</b>		
Tram Speed Level and Empty — Zero Grade		—	5.79 km/h	<b>3.6 mph</b>
Tram Speed Level and Loaded — Zero Grade		—	5.14 km/h	<b>3.2 mph</b>
Hydraulic Pump Motor	11.9 kW	<b>16 hp</b>	11.9 kW	<b>16 hp</b>
Hydraulic Reservoir	189.3 L	<b>50 U.S. gal</b>	151.4 L	<b>40 U.S. gal</b>
Hydraulic PTO	8273 kPa	<b>1200 psi</b>	8273 kPa	<b>1200 psi</b>
Winch (2-Speed and Load Sensing)	15 900 kg/f	<b>35,000 lbf</b>	20 411.6 kg/f	<b>45,000 lbf</b>
Winch Cable Diameter	19 mm	$\frac{3}{4}$ "	25.4 mm	<b>1"</b>
Frame Oscillation — Total		<b>20 degrees</b>		<b>40 degrees</b>
Length:				
with 2083 mm ( <b>82"</b> ) Lifting Forks	10 262 mm	<b>33'8"</b>	—	—
with 2134 mm ( <b>84"</b> ) Lifting Forks		—	10 465 mm	<b>34'4"</b>
Width:				
with Attachments		—	2819 mm	<b>9'3"</b>
with Attachments and 965 mm ( <b>38"</b> ) Tires	2845 mm	<b>9'4"</b>	—	—
with Attachments and 1118 mm ( <b>44"</b> ) Tires	2897 mm	<b>9'6"</b>	—	—
Wheelbase	4953 mm	<b>16'3"</b>	4978 mm	<b>16'4"</b>
Cab Height:				
Standard Cab Adjustment with 965 mm ( <b>38"</b> ) Tires	1321-1575 mm	<b>52-62"</b>	—	—
Standard Cab Adjustment with 1118 mm ( <b>44"</b> ) Tires	1397-1651 mm	<b>55-65"</b>	—	—
508 mm ( <b>20"</b> ) Cab with 1219 mm ( <b>48"</b> ) Tires		—	1727 mm	<b>68"</b>
Turning Radius — Inside	4013 mm	<b>13'2"</b>	4139 mm	<b>13'7"</b>
Turning Radius — Outside	7061 mm	<b>23'2"</b>	7214 mm	<b>23'8"</b>

\*With 1117.6 mm (**44"**) tires.

\*\*With 48 x 22 solid tires.

Model	SH650		SH680	
Lift and Carry Capacity (Tire Dependent)	45.4 tonnes*	<b>50 tons*</b>	80 tonnes**	<b>90 tons**</b>
Machine Weight:				
less Battery	31 751 kg	<b>70,000 lb</b>	55 565 kg	<b>122,500 lb</b>
with 64-125-33, 200 Amp Hour Battery	46 039 kg	<b>101,500 lb</b>		
with 340 kW Hour Battery Pack	—		89 585 kg	<b>197,500 lb</b>
Drive Train Tram Motors		<b>2</b>		<b>4</b>
Drive Train Tram Motor Power (each)	37.3 kW	<b>50 hp</b>	74 kW	<b>100 hp</b>
Tram Speed Level and Empty — Zero Grade	5.1 km/h	<b>3.2 mph</b>	5.8 km/h	<b>3.6 mph</b>
Tram Speed Level and Loaded — Zero Grade	3.8 km/h	<b>2.4 mph</b>	5.8 km/h	<b>3.6 mph</b>
Hydraulic Pump Motor	11.9 kW	<b>16 hp</b>	75 kW	<b>100 hp</b>
Hydraulic Reservoir	189.3 L	<b>50 U.S. gal</b>	246 L	<b>65 U.S. gal</b>
Hydraulic PTO	17 581 kPa	<b>2550 psi</b>	17 581 kPa	<b>2550 psi</b>
Winch (2-Speed and Load Sensing)	31 751 kg/f	<b>70,000 lbf</b>	45 300 kgf***	<b>100,000 lbf***</b>
Winch Cable Diameter	22.2 mm	<b>7/8"</b>	35 mm	<b>1 3/8"</b>
Frame Oscillation — Total		<b>40 degrees</b>		<b>20 degrees</b>
Length:				
with 2134 mm ( <b>84"</b> ) Lifting Forks	11 679 mm	<b>38'4"</b>	12 801 mm	<b>42'0"</b>
Width:				
with Attachments	—		3454 mm**	<b>11'4"***</b>
with Attachments and 1219 mm ( <b>48"</b> ) Tires	2819 mm	<b>9'3"</b>		
with Attachments and 1371 mm ( <b>54"</b> ) Tires	3021 mm	<b>9'11"</b>		
Wheelbase	5156 mm	<b>16'11"</b>	5486 mm	<b>18'0"</b>
Cab Height:				
Standard Cab Adjustments with 1219 mm ( <b>48"</b> ) Tires	1448-1702 mm	<b>57-67"</b>	—	
Standard Cabs with 1371 mm ( <b>54"</b> ) Tires	1524-1778 mm	<b>60-70"</b>	—	
Standard Cabs with 1397 mm ( <b>55"</b> ) Tires	—		1778-2032 mm	<b>70-80"</b>
Turning Radius — Inside	4140 mm	<b>13'7"</b>	4140 mm	<b>13'7"</b>
Turning Radius — Outside	7214 mm	<b>23'8"</b>	7214 mm	<b>23'8"</b>

\*With 54 x 26 solid tires.

\*\*With 55 x 33 solid tires.

\*\*\*Variable speed winch.

**SH640/SH640B  
 TRACTIVE EFFORT vs. SPEED  
 — LOADED**

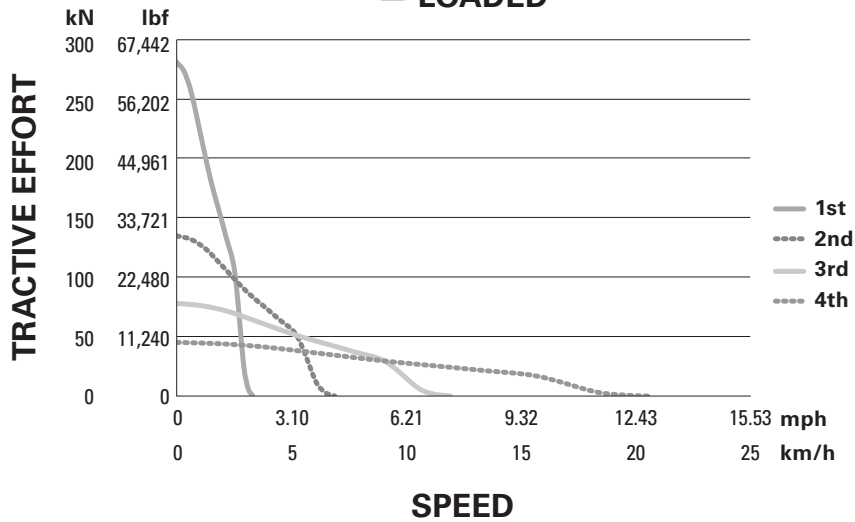

**SH660/SH660B  
 TRACTIVE EFFORT vs. SPEED  
 — LOADED**

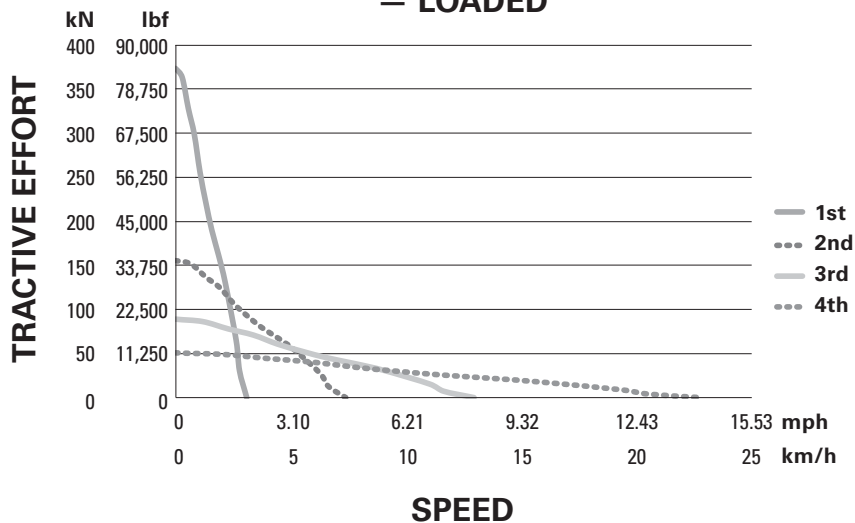

**SH640/SH640B**  
**% GRADE vs. SPEED — LOADED**

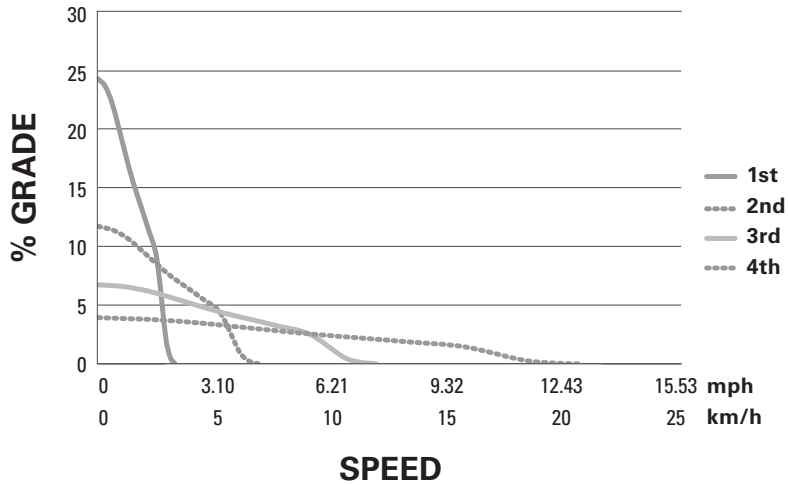

**SH660/SH660B**  
**% GRADE vs. SPEED — LOADED**

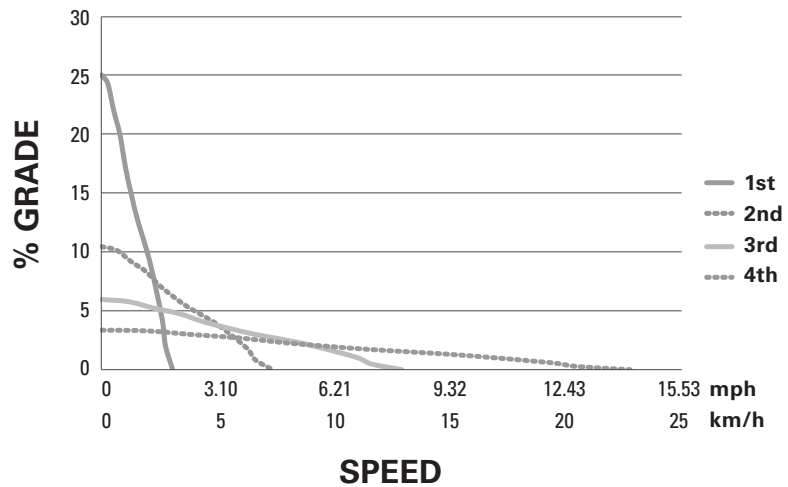

### SH640/SH640B LIFT CAPABILITY

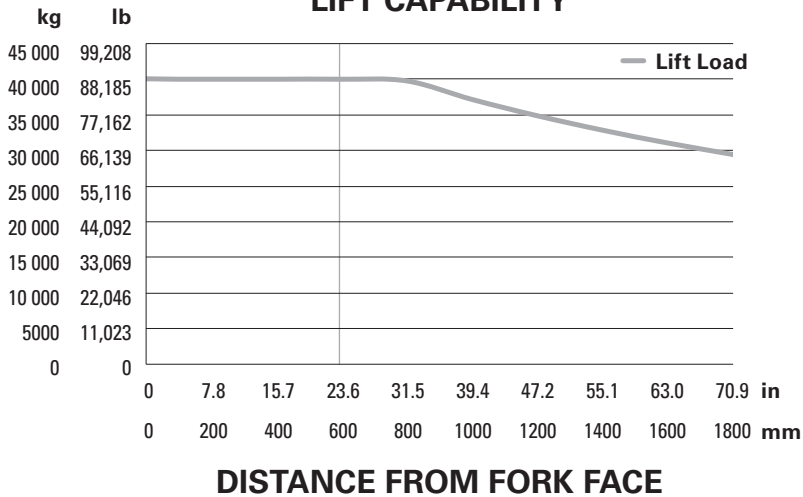

### SH660/SH660B LIFT CAPABILITY

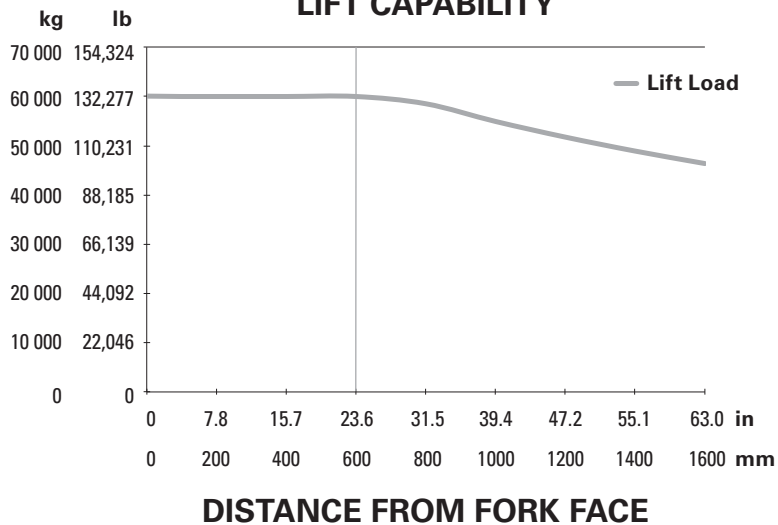

## SHIELD TRAILERS



### Features

When used in combination with the CL210 and CL215 LHD machines, the SH150 is the most cost-effective solution for mines that require versatile equipment able to perform multiple tasks. The SH150 shield trailer offers the following features:

- A fifth wheel connection attachment.
- Optional power assist for soft and inconsistent floor conditions.
- Hydraulic raise and lower to facilitate loading and unloading of the cargo.
- Ejection cylinders that facilitate unloading the trailer.
- Spring applied, hydraulic released brake.



MODEL	SH150		SH150 Power Assist	
Tractor Units	CL210 and CL215		CL210, CL215 and SH660	
Hydraulic Power Assist Option Traction Effort: Speed Unloaded	Reference machine spec 55 x 25 Soild		Up to 3 km/h (1.9 mph) in PA reference machine spec 55 x 25 Soild	
Tire Size				
Nominal Payload Capacity:				
CL210 Tractor	36 000 kg	<b>79,366 lb</b>	36 000 kg	<b>79,366 lb</b>
CL215 Tractor	50 000 kg	<b>110,321 lb</b>	55 000 kg	<b>121,254 lb</b>
SH660 Tractor	N/A		55 000 kg	<b>121,254 lb</b>
Winch Pull	30 000 kg	<b>66,138 lb</b>	30 000 kg	<b>66,138 lb</b>
Tare Machine Operating Weight	14 260 kg	<b>31,437 lb</b>	14 260 kg	<b>31,437 lb</b>
Length — Overall 1750 mm ( <b>68.9"</b> )	5760 mm	<b>226.7"</b>	5760 mm	<b>226.7"</b>
— Overall 2200 mm ( <b>86.6"</b> )	5600 mm	<b>220.5"</b>	5600 mm	<b>220.5"</b>
Width — Overall 1750 mm ( <b>68.9"</b> )	3430 mm	<b>135"</b>	3530 mm	<b>139"</b>
— Overall 2200 mm ( <b>86.6"</b> )	3880 mm	<b>152.7"</b>	3980 mm	<b>153.1"</b>
Height — Overall Raised	1835 mm	<b>72.2"</b>	1835 mm	<b>72.2"</b>
— Overall Lowered	1585 mm	<b>62.4"</b>	1585 mm	<b>62.4"</b>
— Ground Clearance Raised	250 mm	<b>10"</b>	250 mm	<b>10"</b>
Turning Radius — Outer	7480 mm	<b>294.5"</b>	7480 mm	<b>294.5"</b>
— Inner	3120 mm	<b>122.8"</b>	3120 mm	<b>122.8"</b>
Angle — Articulation	> 45°		> 45°	
Travel Speeds Loaded Power Assist:	km/h	mph	km/h	mph
Forward — 1st Gear				
CL210	N/A		3	<b>1.9</b>
CL215	N/A		4	<b>2.5</b>
SH660	N/A		3	<b>1.9</b>
Reverse — 1st Gear				
CL210	N/A		3	<b>1.9</b>
CL215	N/A		4	<b>2.5</b>
SH660	N/A		3	<b>1.9</b>
Refill Capacity:				
Axles	19.5 L	<b>5.2 U.S. gal</b>	19.5 L	<b>5.2 U.S. gal</b>

N/A = Not Available.

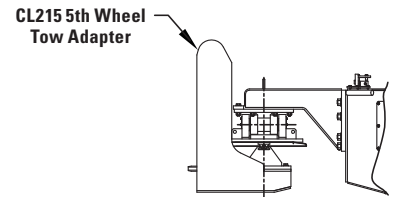
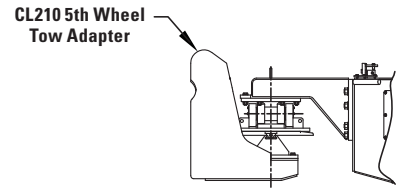
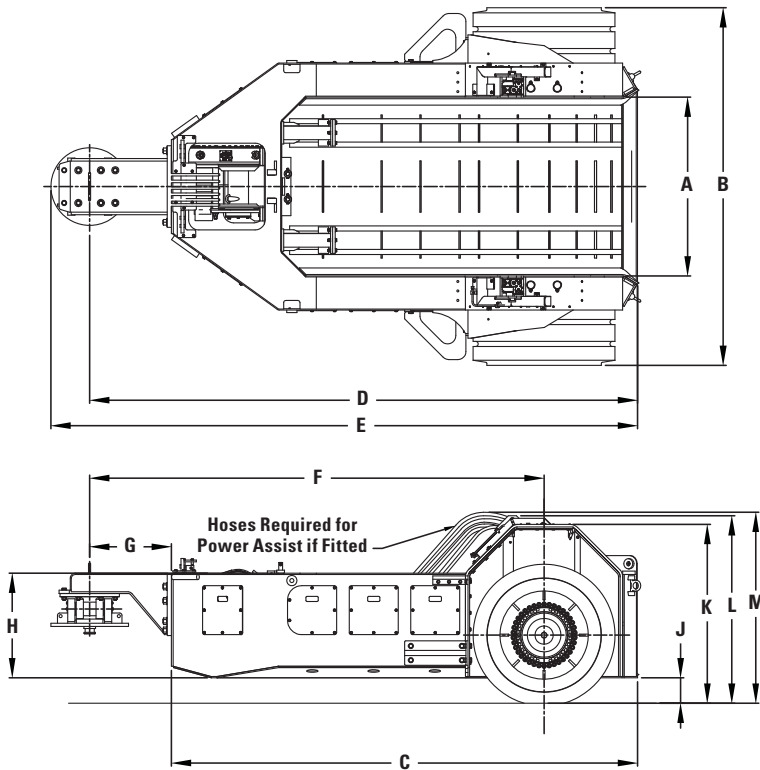

**Dimensions** (All dimensions are approximate.)

Trailer Model	Power Assist				Non-Power Assist			
	mm	in	mm	in	mm	in	mm	in
<b>A</b> Width – Inside	1750	68.9	2200	86.6	1750	68.9	2200	86.6
<b>B</b> Width – Overall Over Wheels	3530	139.0	3980	156.7	3430	135.0	3880	152.8
<b>C</b> Length – End to 5th Wheel Mount	4570	179.9	4420	174.0	4570	179.9	4420	174.0
<b>D</b> Length – End to 5th Wheel Pivot	5390	212.2	5220	205.5	5390	212.2	5220	205.5
<b>E</b> Length – Overall	5760	226.8	5600	220.5	5760	226.8	5600	220.5
<b>F</b> Length – Center of Wheel to 5th Wheel Pivot	4450	175.2	4300	169.3	4450	175.2	4300	169.3
<b>G</b> Length – 5th Wheel Stand Off	799	31.5	799	31.5	799	31.5	799	31.5
<b>H</b> Height – To Top of 5th Wheel Loaded	1024	40.3	1024	40.3	1024	40.3	1024	40.3
<b>J</b> Ground Clearance Lifted	250	9.8	250	9.8	250	9.8	250	9.8
<b>K</b> Height – To Top of Wheel Arch Lifted	1750	68.9	1750	68.9	1750	68.9	1750	68.9
<b>L</b> Height – To Top of Guard Lifted	1835	72.2	1835	72.2	1835	72.2	1835	72.2
<b>M</b> Height in Travel Position	1870	73.6	1870	73.6	1870	73.6	1870	73.6

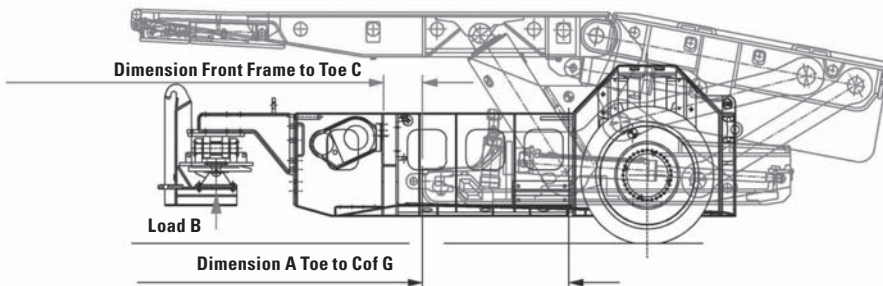

**SH150 Load Setting Table**

Distance inside frame to wheel centerline .....	2570 mm (101.2")
Standard distance 150 mm (5.9") offset to front frame. ....	2420 mm (95.3")
Distance wheel centerline to toe interference on frame .....	2340 mm (92.1")
Distance to the 560 mm (22") stop to wheel centerline. ....	2010 mm (79.1")
Distance 5th wheel centerline to wheel centerline .....	4451 mm (175.2")
Distance 5th wheel centerline trailer Cof G .....	3515 mm (138.5")
Standard weight of trailer and 5th wheel .....	15 tonnes (16.5 tons)
Load of standard trailer only on 5th wheel .....	3.2 tonnes (3.5 tons)
CL210 maximum rated load .....	10 tonnes (11 tons)
CL215 maximum rated load .....	15 tonnes (16.5 tons)

**Distance Inside SH150 Frame Front to Toe "C"**

Shield Weight	30 tonnes (33.1 tons)			
Distance Toe to CofG of Shield Dimension "A"	1300 mm (51.2")	1500 mm (59.1")	1700 mm (67")	1900 mm (74.8")
<b>Load on "Fork" Rating "B" tonnes (tons)</b>	7.94 tonnes	6.59 tonnes	5.24 tonnes	3.90 tonnes
<b>Load at 5th with Toe on Standard Stops</b>	<b>(8.75 tons)</b>	<b>(7.26 tons)</b>	<b>(5.78 tons)</b>	<b>(4.30 tons)</b>
5 tonnes (5.5 tons)	996 mm (39.2")	796 mm (31.3")	596 mm (23.5")	396 mm (15.6")
8 tonnes (8.8 tons)	551 mm (21.7")	351 mm (13.8")	151 mm (5.9")	-49 mm (-1.9")
10 tonnes (11 tons)	254 mm (10")	54 mm (2.1")	-146 mm (-5.7")	-346 mm (-13.6")
12 tonnes (13.2 tons)	-42 mm (-1.7")	-242 mm (-9.5")	-442 mm (-17.4")	-642 mm (-25.3")
15 tonnes (16.5 tons)	-488 mm (-19.2")	-688 mm (-27.1")	-888 mm (-34.9")	-1088 mm (-42.8")
18 tonnes (19.8 tons)	-933 mm (-36.7")	-1133 mm (-44.6")	-1333 mm (-52.5")	-1533 mm (-60.4")

Shield Weight	35 tonnes (38.6 tons)			
Distance Toe to CofG of Shield Dimension "A"	1300 mm (51.2")	1500 mm (59.1")	1700 mm (67")	1900 mm (74.8")
<b>Load on "Fork" Rating "B" tonnes (tons)</b>	8.74 tonnes	7.16 tonnes	5.59 tonnes	4.02 tonnes
<b>Load at 5th with Toe on Standard Stops</b>	<b>(9.63 tons)</b>	<b>(7.89 tons)</b>	<b>(6.16 tons)</b>	<b>(4.43 tons)</b>
5 tonnes (5.5 tons)	1035 mm (40.7")	835 mm (32.8")	635 mm (25")	435 mm (17.1")
8 tonnes (8.8 tons)	654 mm (25.7")	454 mm (17.8")	254 mm (10")	54 mm (2.1")
10 tonnes (11 tons)	399 mm (15.7")	199 mm (7.8")	-1 mm (-0.03")	-201 mm (-7.9")
12 tonnes (13.2 tons)	145 mm (5.7")	-55 mm (-2.2")	-255 mm (-10")	-455 mm (-17.9")
15 tonnes (16.5 tons)	-236 mm (-9.3")	-436 mm (-17.2")	-636 mm (-25")	-836 mm (-32.9")
18 tonnes (19.8 tons)	-618 mm (-24.3")	-818 mm (-32.2")	-1018 mm (-40.1")	-1218 mm (-47.9")

Shield will foul wall and or front	
Shield CofG too close to wheel	
Setting distance acceptable – please ensure maximum loads for the tractor are not exceeded	

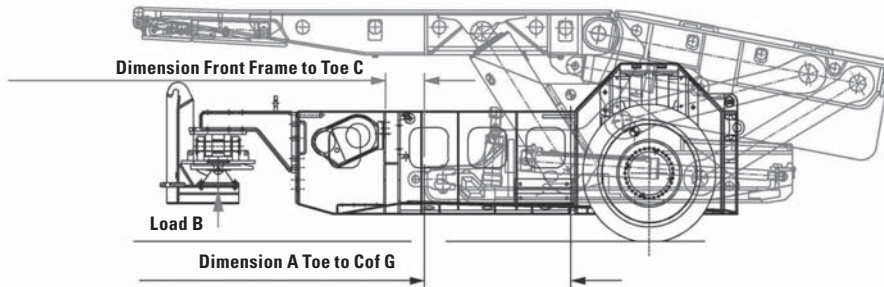

### SH150 Load Setting Table

Distance inside frame to wheel centerline .....	2570 mm (101.2")
Standard distance 150 mm (5.9") offset to front frame. ....	2420 mm (95.3")
Distance wheel centerline to toe interference on frame .....	2340 mm (92.1")
Distance to the 560 mm (22") stop to wheel centerline. ....	2010 mm (79.1")
Distance 5th wheel centerline to wheel centerline .....	4451 mm (175.2")
Distance 5th wheel centerline trailer Cof G .....	3515 mm (138.5")
Standard weight of trailer and 5th wheel .....	15 tonnes (16.5 tons)
Load of standard trailer only on 5th wheel .....	3.2 tonnes (3.5 tons)
CL210 maximum rated load .....	10 tonnes (11 tons)
CL215 maximum rated load .....	15 tonnes (16.5 tons)

### Distance Inside SH150 Frame Front to Toe "C"

Shield Weight	40 tonnes (44.1 tons)			
Distance Toe to CofG of Shield Dimension "A"	1300 mm (51.2")	1500 mm (59.1")	1700 mm (67")	1900 mm (74.8")
Load on "Fork" Rating "B" tonnes (tons)	9.53 tonnes (10.05 tons)	7.74 tonnes (8.53 tons)	5.94 tonnes (6.54 tons)	4.14 tonnes (4.56 tons)
Load at 5th with Toe on Standard Stops				
5 tonnes (5.5 tons)	1065 mm (41.9")	865 mm (34")	665 mm (26.2")	465 mm (18.3")
8 tonnes (8.8 tons)	731 mm (28.8")	531 mm (20.9")	331 mm (13")	131 mm (5.2")
10 tonnes (11 tons)	508 mm (20")	308 mm (12.1")	108 mm (4.3")	-92 mm (-3.6")
12 tonnes (13.2 tons)	286 mm (11.25")	86 mm (3.4")	-114 mm (-4.5")	-314 mm (-12.4")
15 tonnes (16.5 tons)	-48 mm (-1.9")	-248 mm (-9.8")	-448 mm (-17.6")	-648 mm (-25.5")
18 tonnes (19.8 tons)	-382 mm (-15")	-582 mm (-22.9")	-782 mm (-30.8")	-982 mm (-38.7")

Shield Weight	45 tonnes (49.6 tons)			
Distance Toe to CofG of Shield Dimension "A"	1300 mm (51.2")	1500 mm (59.1")	1700 mm (67")	1900 mm (74.8")
Load on "Fork" Rating "B" tonnes (tons)	10.33 tonnes (11.39 tons)	8.31 tonnes (9.16 tons)	6.29 tonnes (6.93 tons)	4.27 tonnes (4.71 tons)
Load at 5th with Toe on Standard Stops				
5 tonnes (5.5 tons)	1087 mm (42.8")	887 mm (34.9")	687 mm (27")	487 mm (19.2")
8 tonnes (8.8 tons)	791 mm (31.1")	591 mm (23.3")	391 mm (15.4")	191 mm (7.5")
10 tonnes (11 tons)	593 mm (23.3")	393 mm (15.5")	193 mm (7.6")	-7 mm (-0.3")
12 tonnes (13.2 tons)	395 mm (15.5")	195 mm (7.7")	-5 mm (-0.2")	-205 mm (-8.1")
15 tonnes (16.5 tons)	98 mm (3.9")	-102 mm (-4")	-302 mm (-11.9")	-502 mm (-19.8")
18 tonnes (19.8 tons)	-198 mm (-7.8")	-398 mm (-15.7")	-598 mm (-23.5")	-798 mm (-31.4")

Shield will foul wall and or front	
Shield CofG too close to wheel	
Setting distance acceptable – please ensure maximum loads for the tractor are not exceeded	

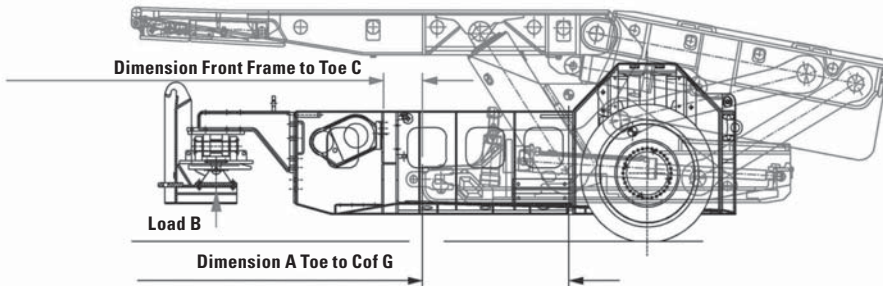

**SH150 Load Setting Table**

Distance inside frame to wheel centerline .....	2570 mm (101.2")
Standard distance 150 mm (5.9") offset to front frame. ....	2420 mm (95.3")
Distance wheel centerline to toe interference on frame .....	2340 mm (92.1")
Distance to the 560 mm (22") stop to wheel centerline. ....	2010 mm (79.1")
Distance 5th wheel centerline to wheel centerline .....	4451 mm (175.2")
Distance 5th wheel centerline trailer Cof G .....	3515 mm (138.5")
Standard weight of trailer and 5th wheel .....	15 tonnes (16.5 tons)
Load of standard trailer only on 5th wheel .....	3.2 tonnes (3.5 tons)
CL210 maximum rated load .....	10 tonnes (11 tons)
CL215 maximum rated load .....	15 tonnes (16.5 tons)

**Distance Inside SH150 Frame Front to Toe "C"**

Shield Weight	50 tonnes (55.1 tons)			
Distance Toe to CofG of Shield Dimension "A"	1300 mm (51.2")	1500 mm (59.1")	1700 mm (67")	1900 mm (74.8")
Load on "Fork" Rating "B" tonnes (tons)	11.13 tonnes (12.27 tons)	8.88 tonnes (9.79 tons)	6.64 tonnes (7.32 tons)	4.39 tonnes (4.84 tons)
Load at 5th with Toe on Standard Stops				
5 tonnes (5.5 tons)	1106 mm (43.5")	906 mm (35.7")	706 mm (27.8")	506 mm (19.9")
8 tonnes (8.8 tons)	839 mm (33")	639 mm (25.2")	439 mm (17.3")	239 mm (9.4")
10 tonnes (11 tons)	661 mm (26")	461 mm (18.1")	261 mm (10.3")	61 mm (2.4")
12 tonnes (13.2 tons)	483 mm (19")	283 mm (11.1")	83 mm (3.3")	-117 mm (-4.6")
15 tonnes (16.5 tons)	216 mm (8.5")	16 mm (0.6")	-185 mm (-7.3")	-385 mm (-15.2")
18 tonnes (19.8 tons)	-52 mm (-2")	-252 mm (-9.9")	-452 mm (-17.8")	-652 mm (-25.7")

Shield Weight	55 tonnes (60.6 tons)			
Distance Toe to CofG of Shield Dimension "A"	1300 mm (51.2")	1500 mm (59.1")	1700 mm (67")	1900 mm (74.8")
Load on "Fork" Rating "B" tonnes (tons)	11.93 tonnes (13.15 tons)	9.46 tonnes (10.43 tons)	6.98 tonnes (7.69 tons)	4.51 tonnes (4.97 tons)
Load at 5th with Toe on Standard Stops				
5 tonnes (5.5 tons)	1121 mm (44.1")	921 mm (36.3")	721 mm (28.4")	521 mm (20.5")
8 tonnes (8.8 tons)	878 mm (34.6")	678 mm (26.7")	478 mm (18.8")	278 mm (10.9")
10 tonnes (11 tons)	716 mm (28.2")	516 mm (20.3")	316 mm (12.4")	116 mm (4.6")
12 tonnes (13.2 tons)	554 mm (21.8")	354 mm (13.9")	154 mm (6.1")	-46 mm (-1.8")
15 tonnes (16.5 tons)	311 mm (12.2")	111 mm (4.4")	-89 mm (-3.5")	-289 mm (-11.8")
18 tonnes (19.8 tons)	69 mm (2.7")	-131 mm (-5.2")	-331 mm (-13")	-531 mm (-20.9")

Shield will foul wall and or front	
Shield CofG too close to wheel	
Setting distance acceptable – please ensure maximum loads for the tractor are not exceeded	

# ROOM & PILLAR

## Continuous Miners

## Face Haulers

## Continuous Haulage System

## Feeder Breakers

## Roof Bolter

## Scoops

## LHD Vehicles (Load-Haul-Dumps)

### CONTENTS

#### ROOM & PILLAR

Introduction . . . . .	20-127
Continuous Miners:	
Features . . . . .	20-128
Specifications . . . . .	20-129
Face Haulers:	
Features . . . . .	20-132
Specifications . . . . .	20-133
Dimensions . . . . .	20-134
Continuous Haulage System:	
Features . . . . .	20-135
Specifications . . . . .	20-136
Dimensions . . . . .	20-137
Feeder Breakers:	
Features . . . . .	20-138
Specifications . . . . .	20-139
Roof Bolter:	
Features . . . . .	20-140
Specifications . . . . .	20-141
Scoops:	
Features . . . . .	20-142
Specifications . . . . .	20-143
LHD Vehicles (Load-Haul-Dumps):	
Features . . . . .	20-144
Specifications . . . . .	20-145
Tractive Effort vs. Speed — Loaded . . . . .	20-147
% Grade vs. Speed — Loaded . . . . .	20-149
Lift Capability . . . . .	20-151
Bucket Load Capacities . . . . .	20-153

### INTRODUCTION

Caterpillar is pleased to offer a comprehensive line up of underground room and pillar products that include continuous miners, haulage, roof bolters, and utility vehicles.

We manufacture these product lines in two locations; Houston, Pennsylvania and Beresfield, Australia. Both are Caterpillar facilities that adhere to the Cat Production System, dedicated to providing our customers with defect-free products of the highest quality.

We currently sell room and pillar products into applications that include coal extraction, gypsum, potash and salt production. In some cases, we purpose build the machine to work in these applications. For potash and very hard coal, we offer a tough cut version of our continuous miner, the CM445. For applications like potash that shy away from water use for dust control we offer oil cooled machines that limit water use. We can offer products that are suitable for both extremely low and tall seams.

For additional digital content for these products, including videos, virtual product tours and animations, please visit the product pages on [www.cat.com](http://www.cat.com).

## CONTINUOUS MINERS



### Features

Caterpillar offers a range of continuous miners that are capable of producing in seam heights as low as 762 mm (28") and as high as 4623 mm (182"). Industry leading power and performance are true across the product line, and in some cases, some products are available with tough cut options for extremely hard cutting. We sell this product line into coal, hard coal, phosphate, gypsum, salt, trona and potash applications.

- Minimum to maximum seam height options that range from 762 mm (28") to 4623 mm (182").
- Conveyor width and depth to max out the production capabilities of the cutter head with components that are designed for long life, reduced stretch and simple maintenance when needed.
- Crawlers that in some cases have new geometry to improve chain life and reduce stretch.
- Radio remote control with self diagnostic capabilities is standard.
- Motor ratings that support both U.S. (60 Hz) and international customers.
- AC tram option available on some models.
- Can be sold as part of a complete Cat system (including feeder breakers, roof bolters, haulage and scoops) supported by both local Cat Dealers and Cat Mining Finance.

MODEL	CM210		CM220	
<b>Operating Dimensions:</b>				
Mining Range (recommended)	914-1245 mm	<b>36-49"</b>	1067-2032 mm	<b>42-80"</b>
Minimum Height	762 mm	<b>30"</b>	914 mm	<b>36"</b>
Maximum Reach	1549 mm	<b>61"</b>	2337 mm	<b>92"</b>
Ground Clearance	152 mm	<b>6"</b>	229 mm	<b>9"</b>
Length Rear Bumper to Face	7849 mm	<b>25'9"</b>	7975 mm	<b>26'2"</b>
<b>Transport Dimensions:</b>				
Frame Width (over rub rails)	3175 mm	<b>10'5"</b>	3277 mm	<b>10'9"</b>
Overall Length	10 744 mm	<b>35'3"</b>	10 871 mm	<b>35'8"</b>
Height (over scrubber duct)	711 mm	<b>28"</b>	864 mm	<b>34"</b>
Weight (total)	45.4 tonnes	<b>100,000 lb</b>	56.7 tonnes	<b>125,000 lb</b>
<b>Cutting Unit:</b>				
Cutting Drum Diameter	762 mm	<b>30"</b>	813 mm	<b>32"</b>
Cutting Drum Width	3353 mm	<b>11'0"</b>	3505 mm	<b>11'6"</b>
Cutting Drum Power — Motors (one-hour rating)	2 × 149 kW	<b>2 × 200 hp</b>	2 × 149 kW	<b>2 × 200 hp</b>
<b>Loading Unit:</b>				
Loading Method	<b>4 finger CLA*</b>		<b>6 finger CLA*</b>	
Conveyor Width	762 mm	<b>30"</b>	914 mm	<b>36"</b>
Conveyor Depth	102 mm	<b>4"</b>	152 mm	<b>6"</b>
Loading Capacity	8-10 tonnes/min	<b>9-11 tons/min</b>	14-18 tonnes/min	<b>15-20 tons/min</b>
Conveyor Power — Motors (one-hour rating)	2 × 37 kW	<b>2 × 50 hp</b>	2 × 37 kW	<b>2 × 50 hp</b>
<b>Traction Unit:</b>				
Crawler Chain Width	508 mm	<b>20"</b>	508 mm	<b>20"</b>
Crawler Assembly Length	2921 mm	<b>9'7"</b>	2896 mm	<b>9'6"</b>
Ground Pressure	150 kPa	<b>21.7 psi</b>	189 kPa	<b>27.4 psi</b>
Crawler Speed	0-20 m/min	<b>0-65 ft/min</b>	0-26 m/min	<b>0-85 ft/min</b>
Traction Power — AC/VFD (one-hour rating)	2 × 82 kW	<b>2 × 110 hp</b>	2 × 82 kW	<b>2 × 110 hp</b>
<b>Pump Unit:</b>				
Pump Power — Motor (one-hour rating)	1 × 37 kW	<b>1 × 50 hp</b>	1 × 37 kW	<b>1 × 50 hp</b>
<b>Dust Suppression:</b>				
Scrubber Assembly	<b>Top mounted</b>		<b>Top mounted</b>	
Scrubber Type	<b>Wet bed</b>		<b>Wet bed</b>	
Scrubber Capacity	1.9 m³/sec	<b>4000 ft³/min</b>	2.8 m³/sec	<b>6000 ft³/min</b>
Fan Power — Motor	1 × 10 kW	<b>1 × 13 hp</b>	1 × 22 kW	<b>1 × 30 hp</b>
<b>Electrical System:</b>				
Machine Voltage (International voltages available)	<b>950V AC 60 Hz</b>		<b>950V AC 60 Hz</b>	
Control System	<b>Processor based/radio remote control</b>		<b>Processor based/radio remote control</b>	
<b>Total Installed Power:</b>				
One-hour Rating without Scrubber	575 kW	<b>770 hp</b>	575 kW	<b>770 hp</b>

\*CLA denotes Continuous Loading Arms.

**NOTE:** These specifications are subject to change and may not reflect all options.



MODEL	CM230		CM240	
<b>Operating Dimensions:</b>				
Mining Range (recommended)	1270-2540 mm	<b>50-100"</b>	1676-3632 mm	<b>66-143"</b>
Minimum Height	1118 mm	<b>44"</b>	1530 mm	<b>60"</b>
Maximum Reach	2845 mm	<b>112"</b>	3931 mm	<b>155"</b>
Ground Clearance	229 mm	<b>9"</b>	305 mm	<b>12"</b>
Length Rear Bumper to Face	8153 mm	<b>26'9"</b>	8428 mm	<b>27'8"</b>
<b>Transport Dimensions:</b>				
Frame Width (over rub rails)	3277 mm	<b>10'9"</b>	3175 mm	<b>10'5"</b>
Overall Length	11 049 mm	<b>36'3"</b>	11 589 mm	<b>38'0"</b>
Height (over scrubber duct)	991 mm	<b>39"</b>	1137 mm	<b>45"</b>
Weight (total)	63.5 tonnes	<b>140,000 lb</b>	68 tonnes	<b>150,000 lb</b>
<b>Cutting Unit:</b>				
Cutting Drum Diameter	1118 mm	<b>44"</b>	1118 mm	<b>44"</b>
Cutting Drum Width	3531 mm	<b>11'7"</b>	3531 mm	<b>11'7"</b>
Cutting Drum Power — Motors (one-hour rating)	2 × 201 kW	<b>2 × 270 hp</b>	2 × 201 kW	<b>2 × 270 hp</b>
<b>Loading Unit:</b>				
Loading Method	<b>6 finger CLA</b>		<b>3 finger CLA</b>	
Conveyor Width	914 mm	<b>36"</b>	914 mm	<b>36"</b>
Conveyor Depth	152 mm	<b>6"</b>	305 mm	<b>12"</b>
Loading Capacity	18-23 tonnes/min	<b>20-25 tons/min</b>	18-23 tonnes/min	<b>20-25 tons/min</b>
Conveyor Power — Motors (one-hour rating)	2 × 37 kW	<b>2 × 50 hp</b>	2 × 45 kW	<b>2 × 60 hp</b>
<b>Traction Unit:</b>				
Crawler Chain Width	508 mm	<b>20"</b>	508 mm	<b>20"</b>
Crawler Assembly Length	2896 mm	<b>9'6"</b>	2896 mm	<b>9'6"</b>
Ground Pressure	212 kPa	<b>30.7 psi</b>	227 kPa	<b>32.9 psi</b>
Crawler Speed	0-26 m/min	<b>0-85 ft/min</b>	0-26 m/min	<b>0-85 ft/min</b>
Traction Power — AC/VFD (one-hour rating)	2 × 82 kW	<b>2 × 110 hp</b>	2 × 82 kW	<b>2 × 110 hp</b>
<b>Pump Unit:</b>				
Pump Power — Motor (one-hour rating)	1 × 37 kW	<b>1 × 50 hp</b>	1 × 37 kW	<b>1 × 50 hp</b>
<b>Optional Dust Suppression:</b>				
Scrubber Assembly	<b>Top mounted</b>		<b>Top mounted</b>	
Scrubber Type	<b>Wet bed</b>		<b>Wet bed</b>	
Scrubber Capacity	2.8 m³/sec	<b>6000 ft³/min</b>	3.8 m³/sec	<b>8000 ft³/min</b>
Fan Power — Motor	1 × 22 kW	<b>1 × 30 hp</b>	1 × 22 kW	<b>1 × 30 hp</b>
<b>Electrical System:</b>				
Machine Voltage (International voltages available)	<b>950V AC 60 Hz</b>		<b>950V AC 60 Hz</b>	
Control System	<b>Processor based/radio remote control</b>		<b>Processor based/radio remote control</b>	
<b>Total Installed Power:</b>				
One-hour Rating without Scrubber	680 kW	<b>910 hp</b>	694 kW	<b>930 hp</b>

MODEL	CM340		CM345N*		CM445	
<b>Operating Dimensions:</b>						
Mining Range (recommended)	1676-3810 mm	66-150"	2210-4318 mm	87-170"	1651-3480 mm	65-137"
Minimum Height	1524 mm	60"	2057 mm	81"	1499 mm	59"
Maximum Reach	4115 mm	162"	4623 mm	182"	3785 mm	149"
Ground Clearance	229 mm	9"	356 mm	14"	229 mm	9"
Length Rear Bumper to Face	8131 mm	26'8"	8204 mm	26'11"	8631 mm	28'4"
<b>Transport Dimensions:</b>						
Frame Width (over rub rails)	3483 mm	11'5"	3226 mm	10'7"	3424 mm	11'3"
Overall Length	11 009 mm	36'1"	11 252 mm	36'11"	11 530 mm	37'9"
Height (over scrubber duct)	1118 mm	44"	1651 mm	65"	—	—
Height (over cover line)	—	—	—	—	1394 mm	55"
Weight (total)	70.3 tonnes	155,000 lb	74.8 tonnes	165,000 lb	85.7 tonnes	189,000 lb
<b>Cutting Unit:</b>						
Cutting Drum Diameter	1118 mm	44"	1118 mm	44"	1118 mm	44"
Cutting Drum Width	3581 mm	11'9"	3581 mm	11'9"	3581 mm	11'9"
Cutting Drum Power — Motors (one-hour rating)	2 × 209 kW	2 × 280 hp	2 × 209 kW	2 × 280 hp	2 × 209 kW	2 × 280 hp
<b>Loading Unit:</b>						
Loading Method	3 finger CLA		3 finger CLA		3 finger CLA	
Conveyor Width	965 mm	38"	762 mm	30"	965 mm	38"
Conveyor Depth	305 mm	12"	305 mm	12"	305 mm	12"
Loading Capacity	14-35 tonnes/ min	15-39 tons/ min	14-35 tonnes/ min	15-39 tons/ min	14-35 tonnes/ min	15-39 tons/ min
Conveyor Power — Motors (one-hour rating)	2 × 48 kW	2 × 65 hp	2 × 48 kW	2 × 65 hp	2 × 48 kW	2 × 65 hp
<b>Traction Unit:</b>						
Crawler Chain Width	559 mm	22"	559 mm	22"	559 mm	22"
Crawler Assembly Length	2896 mm	9'6"	2896 mm	9'6"	3551 mm	11'8"
Ground Pressure	213 kPa	30.9 psi	227 kPa	32.9 psi	212 kPa	30.7 psi
Crawler Speed	0-26 m/min	0-85 ft/min	0-23 m/min	0-75 ft/min	0-23 m/min	0-75 ft/min
Traction Power — AC/VFD (one-hour rating)	—	—	2 × 82 kW	2 × 110 hp	2 × 82 kW	2 × 110 hp
Traction Power — DC Motors (one-hour rating)	2 × 56 kW	2 × 75 hp	—	—	—	—
<b>Pump Unit:</b>						
Pump Power — Motor (one-hour rating)	1 × 48 kW	1 × 65 hp	1 × 48 kW	1 × 65 hp	1 × 48 kW	1 × 65 hp
<b>Optional Dust Suppression:</b>						
Scrubber Assembly	Top mounted Wet bed		Top mounted Wet bed		Top mounted Wet bed	
Scrubber Type	3.8 m <sup>3</sup> / sec		4.7 m <sup>3</sup> / sec		4.7 m <sup>3</sup> / sec	
Scrubber Capacity	8000 ft <sup>3</sup> / min		10,000 ft <sup>3</sup> / min		10,000 ft <sup>3</sup> / min	
Fan Power — Motor	1 × 22 kW	1 × 30 hp	1 × 30 kW	1 × 40 hp	1 × 30 kW	1 × 40 hp
<b>Electrical System:</b>						
Machine Voltage (International voltages available)	995V AC 60 Hz		995V AC 60 Hz		995V AC 60 Hz	
Control System	Processor based/ radio remote control		Processor based/ radio remote control		Processor based/ radio remote control	
<b>Total Installed Power:</b>						
One-hour Rating without Scrubber	675 kW	905 hp	727 kW	975 hp	727 kW	975 hp

\*N denotes Narrow.

**FACE HAULERS****Features**

Caterpillar offers and manufactures the FH120 face hauler from its Houston, Pennsylvania facility. The FH120 is a strong and proven product that is purpose built to withstand the hauling conditions and needs of underground mining. The FH120 Face Hauler offers:

- In by flexibility with battery power.
- A capacity of 17 tonnes (19 tons).
- Quick unloading cycles for fast turns.
- Maneuverability with “True Tracking” where the rear wheels follow in the same track left by the fronts.
- Ride quality improved by the use of accumulators to dampen shock loads.
- Modular design that makes service straight forward and provides greater accessibility.
- Efficient use of energy providing long battery discharge life.
- Safety features include tape-switch emergency stops, automatic emergency brakes, operator’s protective canopy, and dry-chemical fire suppression.

<b>MODEL</b>	<b>FH120</b>	
Empty Machine Weights:		
Empty Weight — less Battery	27 025 kg	<b>59,580 lb</b>
Empty Weight with 120-SSP110-19 Battery (237 kW hr/90 Amp hr)	37 566 kg	<b>82,820 lb</b>
Gross Vehicle Weights:	53 896 kg	<b>118,820 lb</b>
Gross Vehicle Weight with 120-SSP110-19 Battery 302 kW hr/1260 Amp hr	39 472 kg	<b>87,020 lb</b>
Design Gross Vehicle Weight	55 801 kg	<b>123,020 lb</b>
Maximum Load Capacity	16 329 kg	<b>36,000 lb</b>
Capacity (by Volume):		
Heaped with No Sideboards	18.5 m <sup>3</sup>	<b>653 ft<sup>3</sup></b>
Heaped with 5 cm (2") sideboards	19.2 m <sup>3</sup>	<b>678 ft<sup>3</sup></b>
Heaped with 10 cm (4") sideboards	19.8 m <sup>3</sup>	<b>702 ft<sup>3</sup></b>
Heaped with 15 cm (6") sideboards	20.5 m <sup>3</sup>	<b>726 ft<sup>3</sup></b>
Height:		
Minimum Canopy Height with 111 cm (44") Tires	129.5 cm	<b>51"</b>
Minimum Canopy Height with 127 cm (50") Tires	137 cm	<b>54"</b>
Length:		
Overall Length	1189 cm	<b>39'0"</b>
Overall Width (Widest Point)	365 cm	<b>12'0"</b>
Wheelbase	605 cm	<b>19'0"</b>
Ground Clearance:		
with 111 cm (44") Tires	25.4 cm	<b>10"</b>
with 127 cm (50") Tires	30.4 cm	<b>12"</b>
Turn Radius:		
Inside turn radius	348 cm	<b>11'5"</b>
Outside turn radius	757 cm	<b>24'10"</b>
Minimum Entry Width	510.5 cm	<b>16'9"</b>
Steering Articulation (Total)	<b>120 degrees</b>	
Tram Speed	0-9.6 km/h	<b>0-6 mph</b>
Discharge Time	<b>24 seconds</b>	
Terrain Compensation (Oscillation from Grade Changes)	<b>15 degrees</b>	
Machine Frame Articulation (Side to Side Movement)	<b>10 degrees</b>	
Power:		
Drive Assembly Motors	2 × 56 kW	<b>2 × 75 hp</b>
Hydraulic Pump Motor	1 × 36 kW	<b>1 × 48 hp</b>
Total Installed Power	148 kW	<b>198 hp</b>

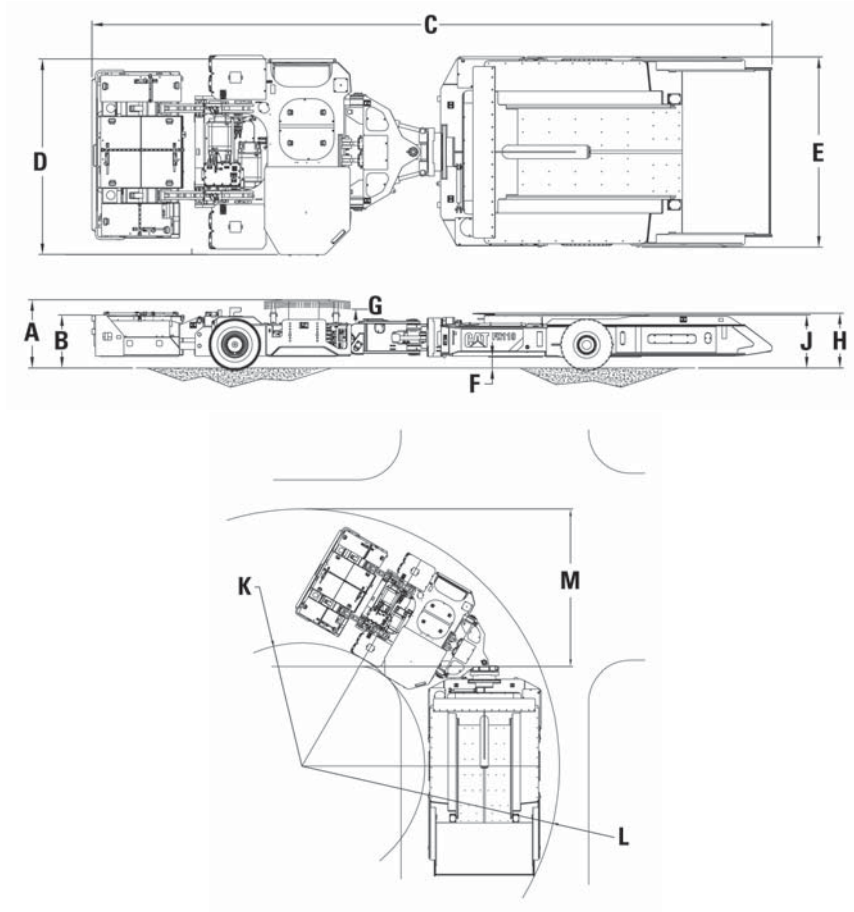

**Dimensions (All dimensions are approximate.)**

**FH120**

<b>A</b> Operating Height	1422-2133 mm	<b>56-84"</b>
<b>B</b> Frame Height	1168-1245 mm	<b>46-49"</b>
<b>C</b> Overall Length	11 880 mm	<b>39'0"</b>
<b>D</b> Width — Extended Deck	3610 mm	<b>11'10"</b>
<b>E</b> Trailer	3660 mm	<b>12'0"</b>
<b>F</b> Ground Clearance*	254 mm	<b>10"</b>
<b>G</b> Minimum Canopy Height*	1290 mm	<b>51"</b>
<b>H</b> Trailer Height at Top of False Bottom*	1245 mm	<b>49"</b>
<b>J</b> Trailer Frame Height*	1168 mm	<b>46"</b>
<b>K</b> Inside Turning Radius	3.48 m	<b>11'5"</b>
<b>L</b> Outside Turning Radius	7.57 m	<b>24'10"</b>
<b>M</b> Minimum Entry Width	4.75 m	<b>15'7"</b>

\*FH120 with 44" tires.

## CONTINUOUS HAULAGE SYSTEM

Continuous Haulage can be tailored for your specific projection, and can be easily installed in new or existing operations. They are as reliable and trouble-free as any piece of face equipment available today.



### Features

- Up to 18 tonne-per minute (20 ton-per-minute) capacity.
- Attached or detached systems (with hopper).
- 0.8 m (30 in) conveyor width.
- Internal gear-driven crawler drive assemblies.
- Forged 0.4 m (14 in) crawlers are designed to provide a balance between tractive ability and yet maintain low ground pressures in soft conditions.
- Available with an optional feeder breaker to size material.
- On board electronics provide diagnosis capability on over 400 events — operators get both a code and words to describe the event.
- Optional spray manifolds can be added for dust control.
- Safety features include “man in position” sensors, operators protective canopy, and e-stops.
- Remote grease points are easily accessible.
- Lighting for excellent work area visibility.
- Chromium carbide overlay plate is used on the conveyor to control wear and provide long service life.
- Torque limiter couplings on conveyor drives protect against spikes and chain breakage.
- Simple hydraulic system with excellent filtration to maintain performance.

<b>MODEL</b>	<b>FH330</b>	
Optimal Seam Heights	914-1270 mm	<b>36-50"</b>
Weights:		
Mobil Bridge Carrier Empty	18 144 kg	<b>40,000 lb</b>
With Bridge Attached at Each End	27 216 kg	<b>60,000 lb</b>
Bridge Empty Weight	9072 kg	<b>20,000 lb</b>
Power:		
Total Installed — Standard	100 kW	<b>135 hp</b>
Conveyor Drive Motor — Standard	2 × 22 kW	<b>2 × 30 hp</b>
Conveyor Drive Motor — Low Profile Outby	1 × 30 kW	<b>1 × 40 hp</b>
Tram Motor	1 × 56 kW	<b>1 × 75 hp</b>
Capacity (Throughput)	18 tonnes/min 816 tonnes/hr	<b>20 tons/min 900 tons/hr</b>
Conveyor:		
Chain Speed	91 m/min	<b>300 ft/min</b>
Flight Spacing	406 mm	<b>16"</b>
Conveyor Chain Take Up	<b>Grease with manual shim locks</b>	
Width	762 mm	<b>30"</b>
Deck	<b>Chromium carbide overlay</b>	
Bridge Carrier Sideboards	76 mm	<b>3"</b>
Ground Pressure:		
Empty	124 kPa	<b>18 psi</b>
Loaded	179 kPa	<b>26 psi</b>
Crawler Take Up	<b>Grease with manual shim locks</b>	
Bridges (Pigs):		
Length Option 1	914 cm	<b>30'0"</b>
Length Option 2	1189 cm	<b>39'0"</b>
Sideboard Option	76 mm	<b>3"</b>

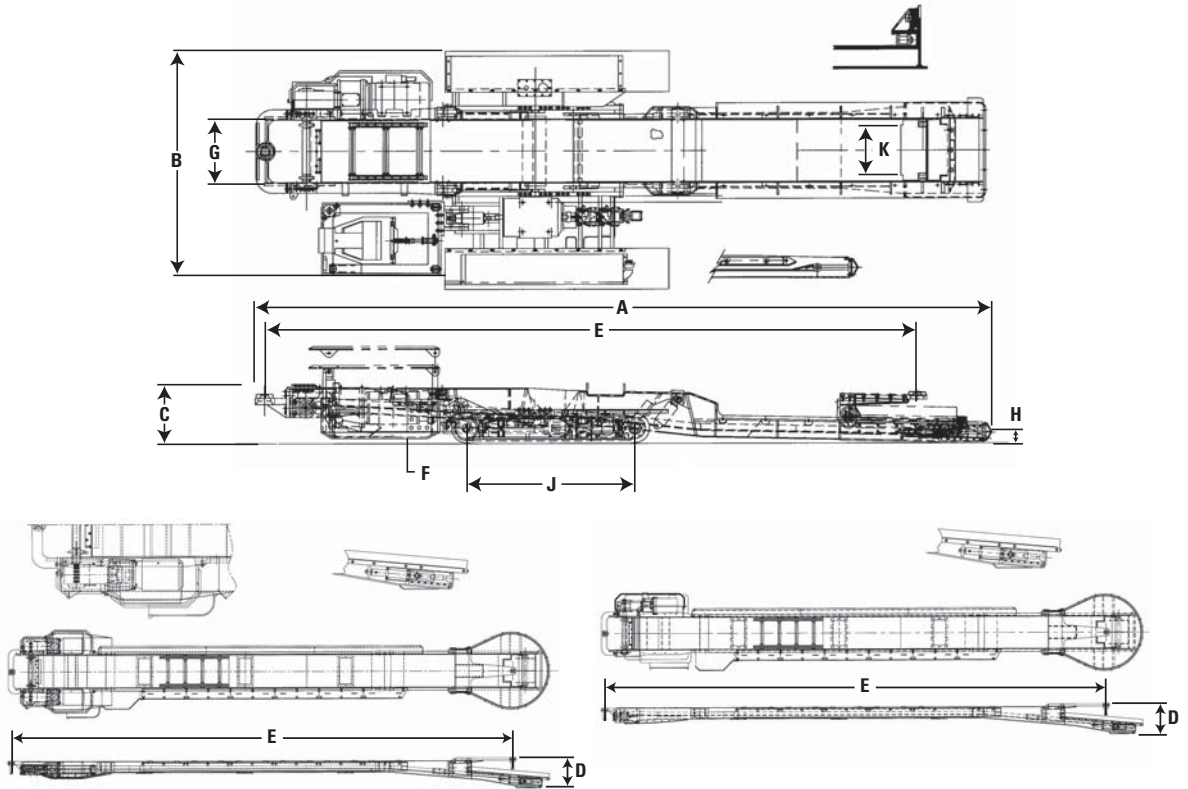

Dimensions — FH330 (All dimensions are approximate.)

	Bridge Carrier		Bridge		Bridge — Low Profile Outby	
<b>A</b> Overall Length	8839 mm	29'0"	11 887 mm	39'0"	11 887 mm	39'0"
	—	—	126 489 mm	41'6"	12 649 mm	41'6"
	—	—	9144 mm	30'0"	9144 mm	30'0"
<b>B</b> Overall Width	2896 mm	9'6"	1905 mm	6'3"	1829 mm	6'0"
	—	—	9906 mm	32'6"	9906 mm	32'6"
	—	—	1905 mm	6'3"	1829 mm	6'0"
<b>C</b> Overall Height	711 mm	28"	711 mm	28"	711 mm	28"
	—	—	—	—	—	—
<b>D</b> Stack-up Height (over bridge without sideboards)	711 mm	28"	—	—	—	—
	711 mm	28"	—	—	—	—
	7925 mm	26'0"	11 887 mm	39'0"	11 887 mm	39'0"
<b>E</b> Length, Mine Reach (pivot to pivot)	—	—	9144 mm	30'0"	9144 mm	30'0"
	—	—	—	—	—	—
	—	—	—	—	—	—
<b>F</b> Ground Clearance	152 mm	6"	—	—	—	—
<b>G</b> Conveyor Width	762 mm	30"	762 mm	30"	762 mm	30"
<b>H</b> Conveyor Depth	152-254 mm	6-10"	152 mm	6"	152 mm	6"
<b>J</b> Crawler Length (center to center)	2045 mm	80.5"	—	—	—	—
<b>K</b> Crawler Width	356 mm	14"	—	—	—	—
Swing	—	—	90 degrees		90 degrees	



## FEEDER BREAKERS

More than 1000 Cat feeder breakers are enabling productivity and profitability on mine sites around the world. Heavy-duty frame construction, high tractive effort and the ability to have the tail piece integrated into the main frame make our feeder breakers the perfect fit for longwall development sections.

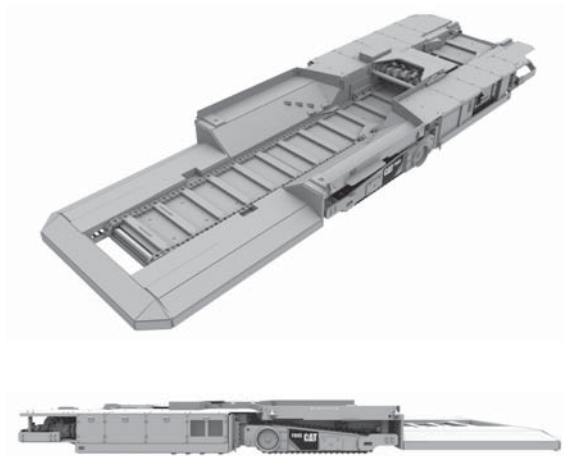

## Features

- Mid and High Seam options available.
- High pick forces and processing rates make these very productive machines.
- Unique spiral-pick breaker bar for hard rock and pyrite balls.
- Heavy duty crawler design providing stability and tractive effort.
- Mechanical conveyor drive standard with optional hydraulic drive available.
- Chrome carbide overlay on conveyor pans for extra long life and wear resistance.
- Torque limiting on conveyor to safeguard against torque spikes and stoppages caused by debris.
- Multiple intake configurations to fit face haulage equipment.

MODEL	FB110		FB140	
Measurements:				
Overall Width	3.30 m	<b>11'2"</b>	3.38 m	<b>11'1"</b>
Receiving End Width	3.27 m	<b>10'9"</b>	3.35 m	<b>11'0"</b>
Conveyor Width	1.42 m	<b>56"</b>	1.42 m	<b>56"</b>
Overall Length	10.26 m	<b>33'8"</b>	10.67 m	<b>35'0"</b>
Breaker Tip to Tip Diameter	635 mm	<b>25"</b>	635 mm, 686 mm, 813 mm	<b>25", 27", 32"</b>
Ground Clearance — Receiving End	25-331 mm	<b>1-13"</b>	181-501 mm	<b>7-19"</b>
Ground Clearance — Discharge End	533-795 mm	<b>21-31"</b>	587-1034 mm	<b>23-40¾"</b>
Frame Height Fixed	1011 mm	<b>40"</b>	940-1448 mm	<b>37-57"</b>
Total Power	150 kW	<b>200 hp</b>	260 kW	<b>350 hp</b>
Tractive Effort	16 163 kg	<b>35,634 lb</b>	56 700 kg	<b>125,000 lb</b>
Tram Speed (Variable)	0-13.7 m/min	<b>0-45 ft/min</b>	0-13.7 m/min	<b>0-45 ft/min</b>
Ground Pressure	21 445 kg/m <sup>2</sup>	<b>30.5 psi</b>	—	<b>—</b>
Maximum Grade Capability		<b>15%</b>		<b>15%</b>
Gross Vehicle Weight	31 752 kg	<b>70,000 lb</b>	29 483-49 895 kg	<b>75,000-110,000 lb</b>
Seam Height Capability	1219-1524 mm	<b>48-60"</b>	1371 mm and higher	<b>54" and higher</b>
Material Throughput	1146 tonnes/hr	<b>1263 tons/hr</b>	1385 tonnes/hr	<b>1526 tons/hr</b>
Breaker Pick Force (Variable)	46 720 kg	<b>103,000 lb</b>	60 000 kg	<b>130,000 lb</b>
Material Compressive Strength	161 Mpa	<b>18,000 psi</b>	200 Mpa	<b>30,000 psi</b>

**ROOF BOLTER**

Caterpillar offers a single roof bolter model, the RB220. This dual boom model is a proven, hard working and well designed product that's simple to operate, simple to maintain and will provide many years of service.

**Features**

- Articulated steering for maneuvering.
- Both horizontal and vertical articulation on this dual boom model.
- Floor and roof avoidance compensation.
- Individual planetary wheel drives — no sprockets or chains.
- User-friendly operator zones.
- Single AC primary drive motor.
- Single hydraulic oil pump.
- Easy access components.
- Quick free-steering towing conversion.
- Streamlined, practical space-planned tram station.
- Safety features include ATRS system, tape-switch emergency stops, automatic emergency brakes, operator's protective canopy, and dry-chemical fire suppression.

<b>MODEL</b>	<b>RB220</b>	
Overall Length with ATRS	7671 mm	25'2"
Chassis Overall Width	2756 mm	9'0.5"
Drill Boom Feed	2337 mm	4'4"
Minimum Trimming Height:		
with 28x12-15 Tires	813 mm	2'8"
with 32x12.5-15 Tires	965 mm	3'2"
with 35x15-15 Tires	1003 mm	3'3.5"
ATRS Reach:		
with 28x12-15 Tires	2438 mm	8'0"
with 32x12.5-15 Tires	2438 mm	8'0"
with 35x15-15 Tires	2438 mm	8'0"
Ground Clearance:		
with 28x12-15 Tires	150 mm	6"
with 32x12.5-15 Tires	203 mm	8"
with 35x15-15 Tires	241 mm	9.5"
Chassis Height:		
with 28x12-15 Tires	686 mm	2'3"
with 32x12.5-15 Tires	737 mm	2'5"
with 35x15-15 Tires	775 mm	2'6.5"
Wheelbase	2007 mm	6'7"
Tram Speed:		
Fast	2.38 m/sec	0-130 ft/min
Slow	1.19 m/sec	0-65 ft/min
Drilling Feed Thrust (maximum)	4536 kg	10,000 lb
Drilling Torque (variable)	420 N·m	310 lbf-ft
Bolt Tightening Torque (adjustable)	258 N·m	190 lbf-ft
Steering Articulation Total		<b>80 degrees</b>
Inside Turning Radius	2.9 m	9'6"
Outside Turning Radius	6.5 m	21'6"

## SCOOPS

With over 40 years of experience and over 6500 battery-powered units produced, Cat scoops are leaders in the industry. These products set the bar for efficient and reliable underground utility vehicles. The SU488 is one of the strongest and most rugged low-profile scoops ever built.

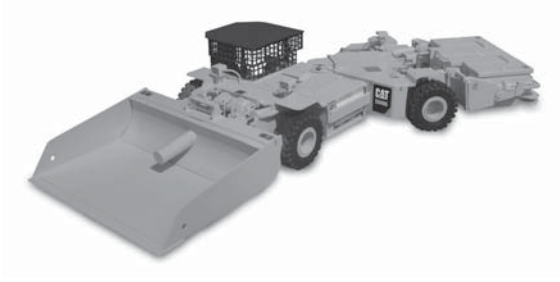

## Features

- Oversize center sections for long life and reliability.
- Safety features include tape-switch emergency stops, automatic emergency brakes, operator's protective canopy, and dry-chemical fire suppression.
- Wet-disc service brakes.
- Proprietary IGBT electric controllers.
- Multi-purpose contoured bottom bucket.
- Planetary wheel drives.
- Ground-level battery change system.
- Optional AC traction.

MODEL	SU488		SU488 D		SU488 L	
Overall Length with Contoured Bucket	8940 mm	<b>29'4"</b>	9880 mm	<b>32'5"</b>	8760 mm	<b>28'9"</b>
Overall Width with Contoured Bucket	2900 mm	<b>9'6"</b>	2920 mm	<b>9'7"</b>	2920 mm	<b>9'7"</b>
Wheelbase	3660 mm	<b>12'0"</b>	3860 mm	<b>12'8"</b>	3710 mm	<b>12'2"</b>
Un-A-Trac Empty Weights — Less Battery	16 650 kg	<b>36,700 lb</b>	—	—	—	—
Scoop Utility Empty Weights Less Battery	—	—	22 680 kg	<b>50,000 lb</b>	—	—
Ground Clearance:					12 700 kg	<b>28,000 lb</b>
with 28x15-15 Tires	—	—	—	—	200 mm	<b>8"</b>
with 32x15-15 Tires	—	—	—	—	240 mm	<b>9.5"</b>
with 35x15-15 Tires	250 mm	<b>10"</b>	267 mm	<b>10.5"</b>	280 mm	<b>11"</b>
with 38x16-15 Tires	330 mm	<b>13"</b>	267 mm	<b>10.5"</b>	—	—
with 44x18-20 Tires	—	—	267 mm	<b>10.5"</b>	—	—
Adjustable Cab Height:						
with 28x15-15 Tires	—	—	—	—	1120 mm	<b>44"</b>
with 32x15-15 Tires	—	—	—	—	1155 mm	<b>45.5"</b>
with 35x15-15 Tires	1270- 1520 mm	<b>4'2"-5'0"</b>	1257 mm	<b>4'1.5"</b>	1190 mm	<b>47"</b>
with 38x16-15 Tires	1350- 1600 mm	<b>4'5"-5'3"</b>	1295 mm	<b>4'3"</b>	—	—
with 44x18-20 Tires	—	—	1372 mm	<b>4'6"</b>	—	—
Main Frame Height:						
with 28x15-15 Tires	—	—	—	—	710 mm	<b>28"</b>
with 32x15-15 Tires	—	—	—	—	760 mm	<b>30"</b>
with 35x15-15 Tires	860 mm	<b>2'10"</b>	978 mm	<b>3'2.5"</b>	800 mm	<b>31.5"</b>
with 38x16-15 Tires	940 mm	<b>3'1"</b>	1016 mm	<b>3'4"</b>	—	—
with 44x18-20 Tires	—	—	1092 mm	<b>3'7"</b>	—	—
Inside Turn Radius	3660 mm	<b>12'0"</b>	3660 mm	<b>12'0"</b>	3660 mm	<b>12'0"</b>
Outside Turn Radius	7315 mm	<b>24'0"</b>	8940 mm	<b>29'4"</b>	7315 mm	<b>24'0"</b>
Steering Articulation	<b>80° total</b>		<b>80°</b>		<b>80° total</b>	
Lift and Carry Capacity:						
at 914 mm ( <b>36"</b> ) from the Face of Lift Plate	14.5 tonnes	<b>16 tons</b>	14.5 tonnes	<b>16 tons</b>	—	—
at 1220 mm ( <b>48"</b> ) from Bucket Mounting Pin	—	—	—	—	9.1 tonnes	<b>10 tons</b>

**LHD VEHICLES (LOAD-HAUL-DUMPS)****Features**

Cat Load Haul Dump machines are equipped to handle all types of utility work in close, underground applications. With work tool versatility and quick disconnect and rapid attachment features, work gets done quickly and efficiently.

With three diesel powered models to choose from, your utility needs can be met with options that include wet or dry type exhaust systems, heavy duty axles, and varying lift and power capabilities.

- Rapid Attachments System (RAS).
- Turbocharged, aftercooled, diesel engine with 4-speed transmission with manual or electronic push-button powershift with forward/reverse mode.
- Wet bath or dry type exhaust system with diesel particulate filtration.
- Optional OEM heavy-duty axles with spring applied, hydraulically released brakes.

MODEL	CL210		CL210B	
	3126*		C7 ACERT**	
Engine Model				
Engine Power — Gross	170 kW	<b>230 hp</b>	171.5 kW	<b>230 hp</b>
Engine Power — Net	154 kW	<b>208 hp</b>	160 kW	<b>216 hp</b>
Tire Size	<b>17.5 R25 L3</b>		<b>17.5 R25 L3</b>	
Nominal Payload Capacity — Trimming	10 000 kg	<b>22,040 lb</b>	10 000 kg	<b>22,040 lb</b>
Nominal Payload Capacity — Truck Loading	10 000 kg	<b>22,040 lb</b>	10 000 kg	<b>22,040 lb</b>
Machine Operating Weight without Tools	22 170 kg	<b>48,862 lb</b>	22 300 kg	<b>49,150 lb</b>
Bucket Size — Heaped Capacity (SAE)	3.5 m <sup>3</sup>	<b>4.6 yd<sup>3</sup></b>	3.5 m <sup>3</sup>	<b>4.6 yd<sup>3</sup></b>
Bucket Size — Struck Capacity	2.7 m <sup>3</sup>	<b>3.5 yd<sup>3</sup></b>	2.7 m <sup>3</sup>	<b>3.5 yd<sup>3</sup></b>
Length — Overall Spade Bucket	9605 mm	<b>378.1"</b>	9620 mm	<b>378.7"</b>
— Overall Forks	9635 mm	<b>379.3"</b>	9650 mm	<b>379.9"</b>
— Wheelbase	3360 mm	<b>132.3"</b>	3360 mm	<b>132.3"</b>
Width — Overall with Bucket	2500 mm	<b>98.4"</b>	2500 mm	<b>98.4"</b>
— Overall without Bucket	2300 mm	<b>90.5"</b>	2340 mm	<b>92.1"</b>
— Over Tires	2310 mm	<b>91"</b>	2310 mm	<b>91"</b>
Height — Overall Bucket Raised	3730 mm	<b>147"</b>	3730 mm	<b>147"</b>
— Overall to Top of Forks Tine	2490 mm	<b>98"</b>	2490 mm	<b>98"</b>
— Body	1590 mm	<b>62.6"</b>	1550 mm	<b>61"</b>
— Top of Canopy Adjustable High	1990 mm	<b>78.3"</b>	2038 mm	<b>80.2"</b>
— Top of Canopy Adjustable Mid	1927 mm	<b>75.9"</b>	1975 mm	<b>77.8"</b>
— Top of Canopy Adjustable Low	1864 mm	<b>73.4"</b>	1912 mm	<b>75.3"</b>
— Ground Clearance	370 mm	<b>15.4"</b>	370 mm	<b>15.4"</b>
Turning Radius — Outer with Bucket	6310 mm	<b>248.4"</b>	6300 mm	<b>248"</b>
— Inner	3110 mm	<b>122.4"</b>	3110 mm	<b>122.4"</b>
Angle — Articulation		<b>±43°</b>		<b>±43°</b>
— Rear Axle Oscillation		<b>±7.5°</b>		<b>±7.5°</b>
— Maximum Bucket Dump Parallel Lift		<b>17°</b>		<b>17°</b>
Hydraulic Cycle Time:				
Raise		<b>8 Sec.</b>		<b>8 Sec.</b>
Dump		<b>5 Sec.</b>		<b>5 Sec.</b>
Lower		<b>6 Sec.</b>		<b>6 Sec.</b>
Total		<b>19 Sec.</b>		<b>19 Sec.</b>
Travel Speeds:	<b>km/h</b>	<b>mph</b>	<b>km/h</b>	<b>mph</b>
Forward — 1st	3.8	<b>2.3</b>	2.9	<b>1.8</b>
— 2nd	7.8	<b>4.8</b>	6.1	<b>3.8</b>
— 3rd	13.6	<b>8.5</b>	10.5	<b>6.5</b>
— 4th	23.4	<b>14.5</b>	18.1	<b>11.3</b>
Reverse — 1st	3.8	<b>2.3</b>	2.9	<b>1.8</b>
— 2nd	7.8	<b>4.8</b>	6.1	<b>3.8</b>
— 3rd	13.6	<b>8.5</b>	10.5	<b>6.5</b>
— 4th	23.4	<b>14.5</b>	18.1	<b>11.3</b>
Tilt Breakout Force (SAE)	10 000 kg	<b>22,040 lb</b>	10 000 kg	<b>22,040 lb</b>
Lift Breakout Force (SAE)	10 000 kg	<b>22,040 lb</b>	10 000 kg	<b>22,040 lb</b>
Refill Capacity:				
Fuel	200 L	<b>53 U.S. gal</b>	200 L	<b>53 U.S. gal</b>
Hydraulic	250 L	<b>66 U.S. gal</b>	250 L	<b>66 U.S. gal</b>
Engine Crankcase with Filter	22 L	<b>5.8 U.S. gal</b>	25 L	<b>6.6 U.S. gal</b>
Transmission	40 L	<b>10.6 U.S. gal</b>	40 L	<b>10.6 U.S. gal</b>
Axles	60 L	<b>15.9 U.S. gal</b>	60 L	<b>15.9 U.S. gal</b>
Drop Box	8 L	<b>2.1 U.S. gal</b>	8 L	<b>2.1 U.S. gal</b>
Exhaust Conditioner/Water	450 L	<b>118.9 U.S. gal</b>	450 L	<b>118.9 U.S. gal</b>
Cooling System	72 L	<b>19 U.S. gal</b>	72 L	<b>19 U.S. gal</b>

\*The 3126 meets U.S. EPA Tier 1, EU Stage I equivalent emission standards.

\*\*The C7 ACERT engine meets U.S. EPA Tier 3, EU Stage IIIA, Japan 2006 (Tier 3) equivalent emission standards.



<b>MODEL</b>	<b>CL215</b>	
Engine Model		<b>3126*</b>
Engine Power — Gross	170 kW	<b>230 hp</b>
Engine Power — Net	154 kW	<b>208 hp</b>
Tire Size		<b>20.5 R25 L3</b>
Nominal Payload Capacity — Trimming	15 000 kg	<b>33,060 lb</b>
Nominal Payload Capacity — Truck Loading	15 000 kg	<b>33,060 lb</b>
Machine Operating Weight without Tools	26 500 kg	<b>48,406 lb</b>
Bucket Size — Heaped Capacity (SAE)	4.5 m <sup>3</sup>	<b>5.8 yd<sup>3</sup></b>
Bucket Size — Struck Capacity	3.5 m <sup>3</sup>	<b>4.6 yd<sup>3</sup></b>
Length — Overall Spade Bucket	10 600 mm	<b>417.3"</b>
— Overall Forks	10 300 mm	<b>405.5"</b>
— Wheelbase	3600 mm	<b>141.7"</b>
Width — Overall with Bucket	2750 mm	<b>108.3"</b>
— Overall without Bucket	2540 mm	<b>100"</b>
— Over Tires	2550 mm	<b>100.4"</b>
Height — Overall Bucket Raised	3300 mm	<b>130"</b>
— Overall to Top of Forks Tine	1900 mm	<b>74.8"</b>
— Body	1650 mm	<b>65"</b>
— Top of Canopy Adjustable High	2182 mm	<b>85.9"</b>
— Top of Canopy Adjustable Mid	2119 mm	<b>83.4"</b>
— Top of Canopy Adjustable Low	2056 mm	<b>80.9"</b>
— Ground Clearance	400 mm	<b>15.7"</b>
Turning Radius — Outer with Bucket	6900 mm	<b>271.6"</b>
— Inner	3300 mm	<b>130"</b>
Angle — Articulation		<b>±43°</b>
— Rear Axle Oscillation		<b>±7.5°</b>
— Maximum Bucket Dump Parallel Lift		<b>45°</b>
Hydraulic Cycle Time:		
Raise		<b>5 Sec.</b>
Dump		<b>9 Sec.</b>
Lower		<b>4 Sec.</b>
Total		<b>18 Sec.</b>
Travel Speeds:	<b>km/h</b>	<b>mph</b>
Forward — 1st	3.1	<b>2</b>
— 2nd	7.4	<b>4.6</b>
— 3rd	13	<b>8.1</b>
— 4th	22.9	<b>14.2</b>
Reverse — 1st	3.1	<b>2</b>
— 2nd	7.4	<b>4.6</b>
— 3rd	13	<b>8.1</b>
— 4th	22.9	<b>14.2</b>
Tilt Breakout Force (SAE)	19 000 kg	<b>41,867 lb</b>
Lift Breakout Force (SAE)	11 000 kg	<b>24,244 lb</b>
Refill Capacity:		
Fuel	300 L	<b>78.3 U.S. gal</b>
Hydraulic	300 L	<b>78.3 U.S. gal</b>
Engine Crankcase with Filter	22 L	<b>5.8 U.S. gal</b>
Transmission	40 L	<b>10.6 U.S. gal</b>
Axles	71 L	<b>18.7 U.S. gal</b>
Drop Box		
Exhaust Conditioner/Water	450 L	<b>118.9 U.S. gal</b>
Cooling System	72 L	<b>19 U.S. gal</b>

\*The 3126 meets U.S. EPA Tier 1, EU Stage I equivalent emission standards.

**CL210  
 TRACTIVE EFFORT vs. SPEED  
 — LOADED**

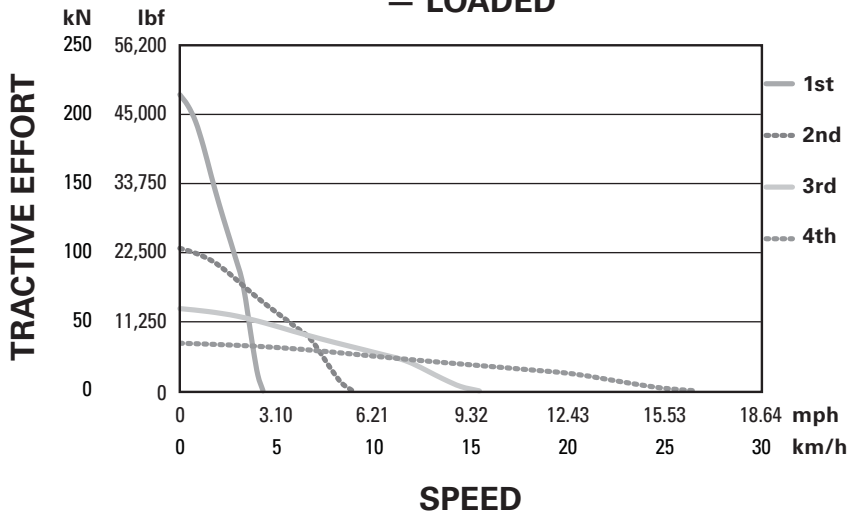

**CL210B  
 TRACTIVE EFFORT vs. SPEED  
 — LOADED**

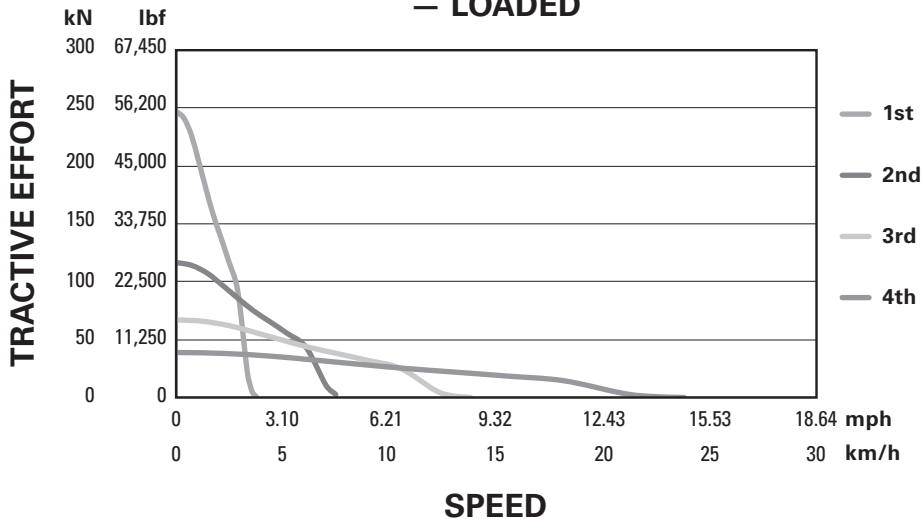

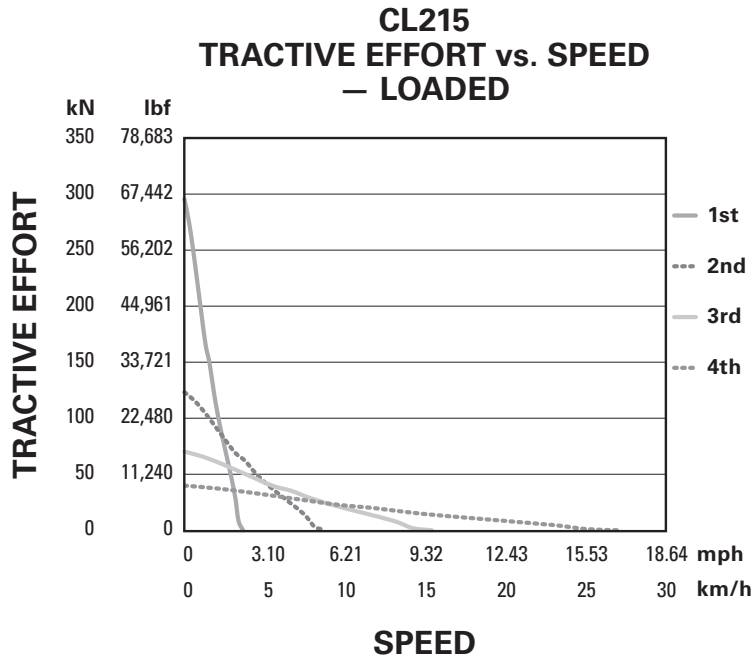

**CL210**  
**% GRADE vs. SPEED — LOADED**

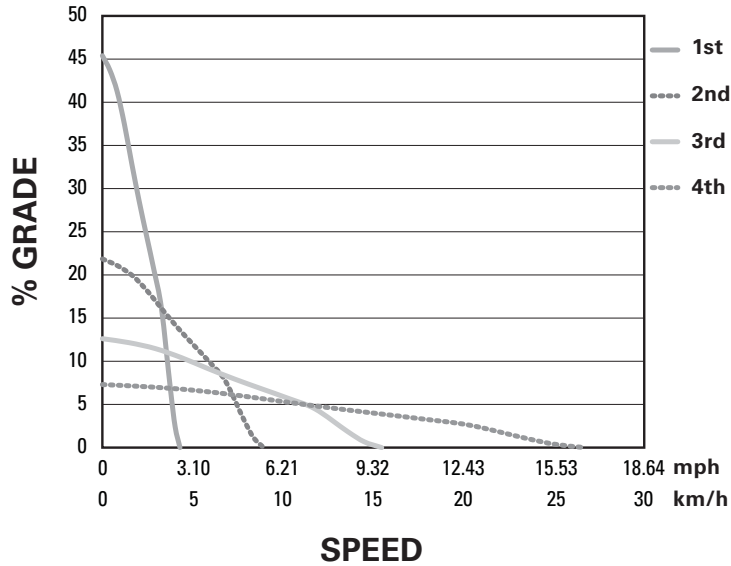

**CL210B**  
**% GRADE vs. SPEED — LOADED**

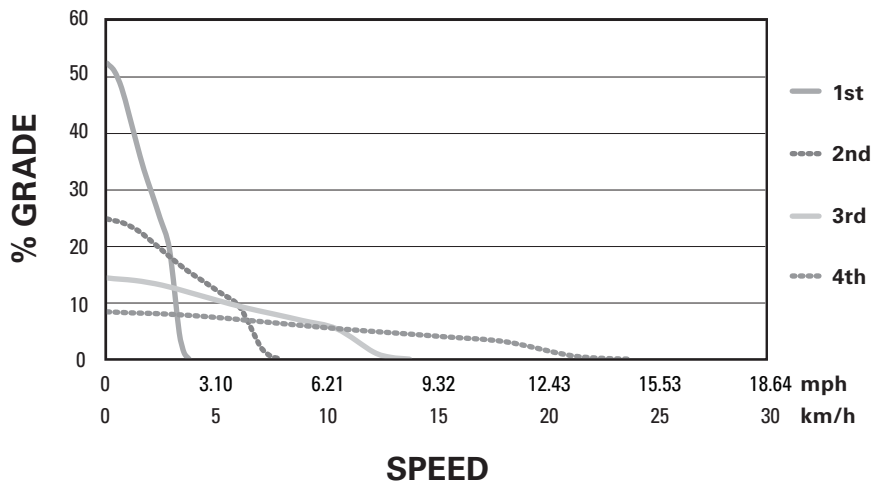

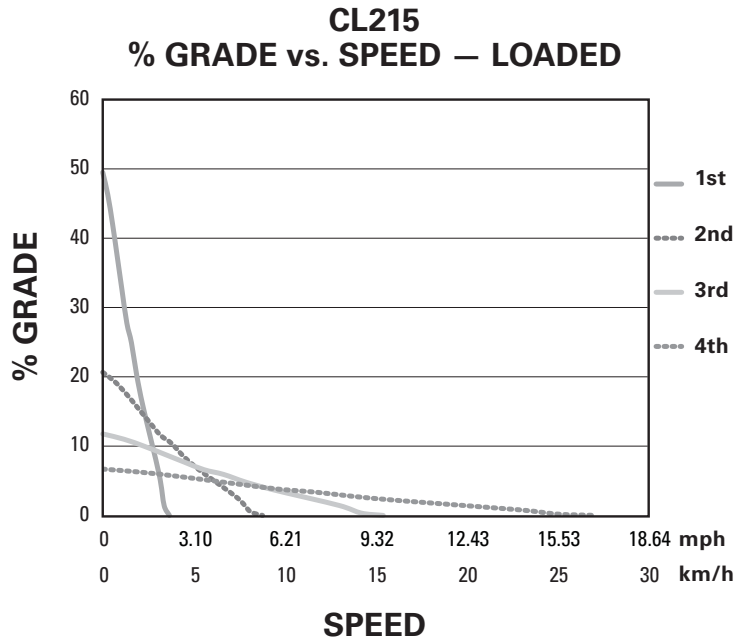

### CL210 LIFT CAPABILITY

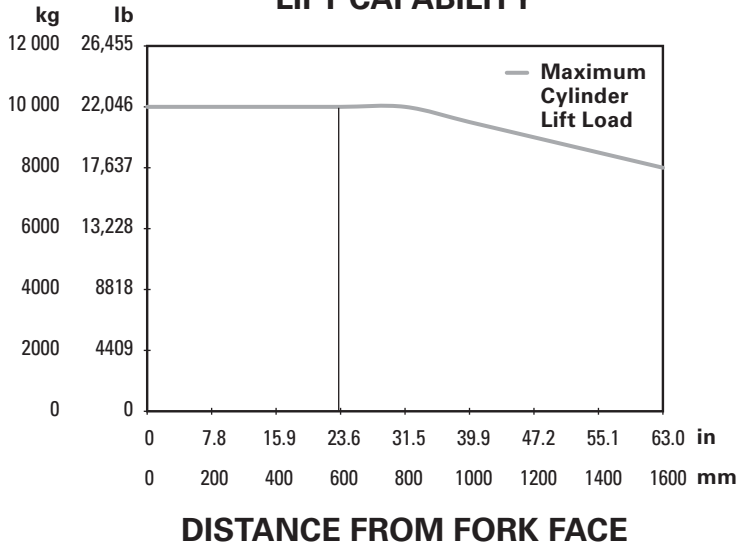

### CL210B LIFT CAPABILITY

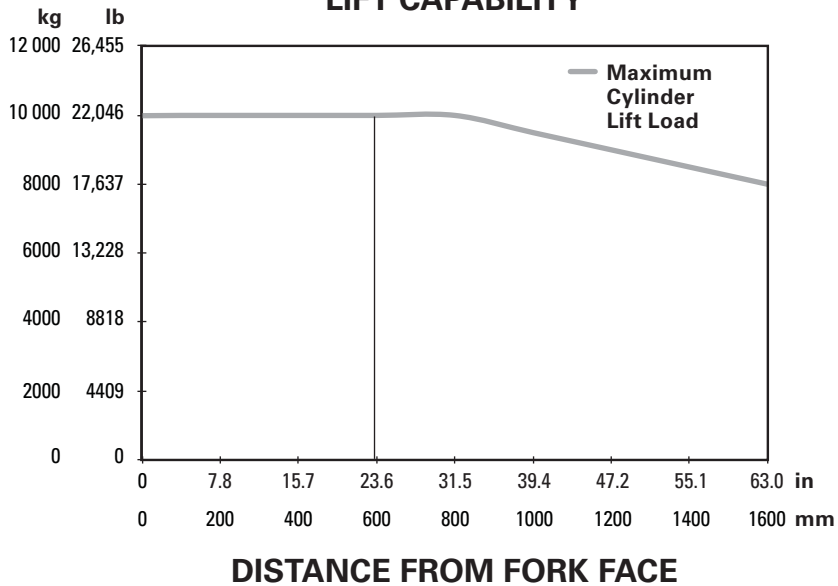

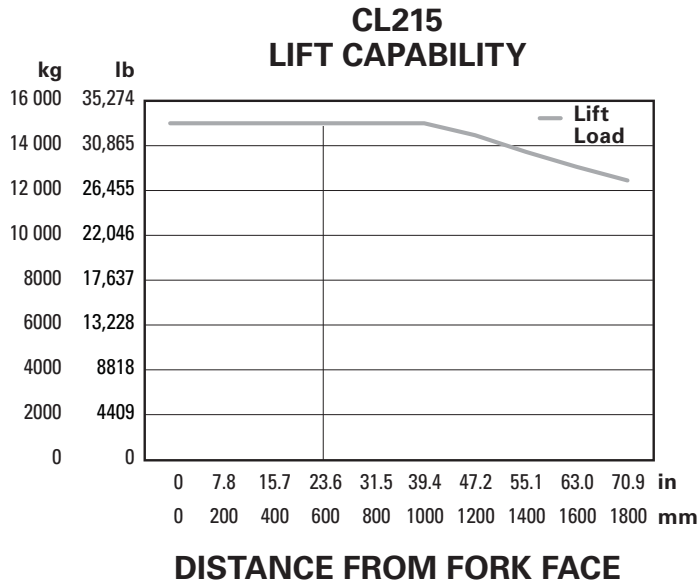

**BUCKET LOAD CAPACITIES**

MODEL	Bucket Type	SAE Capacity	
CL210	Standard		
	Standard Extra		
	Ejector	3.5 m <sup>3</sup>	4.6 yd <sup>3</sup>
CL215	Standard		
	Standard Extra		
	Ejector	4.5 m <sup>3</sup>	5.8 yd <sup>3</sup>





## CONTENTS

Introduction . . . . .	21-2
Safety . . . . .	21-2
Overview . . . . .	21-2

## MATERIAL RECOVERY FACILITIES, SORTING AND TRANSFER STATIONS

Material Recovery Facilities, Sorting, and Transfer Stations . . . . .	21-2
Safety . . . . .	21-2
Technology . . . . .	21-2
Overview: Changing Attitudes in Waste Applications . . . . .	21-2
Primary Roles . . . . .	21-3
MRF's (Material Recovery Facilities), Sorting Stations, Recycling Stations . . . . .	21-3
MRF's, Sorting and Transfer Stations Applications . . . . .	21-3
Types of Transfer Stations . . . . .	21-4
Equipment Selection . . . . .	21-4
Machine Selection Factors . . . . .	21-5
Wheel Loaders . . . . .	21-5
Hydraulic Excavators (Tracked and Wheeled) . . . . .	21-7
Track-Type Tractors . . . . .	21-7
Track Loaders . . . . .	21-7
Landfill Compactors . . . . .	21-7
Work Tools for Material Recovery Facilities, Sorting and Transfer Stations . . . . .	21-7

## LANDFILLS

Landfills . . . . .	21-8
Safety . . . . .	21-8
Technology . . . . .	21-8
Landfill Overview: Landfilling Now and in the Future . . . . .	21-8
Equipment Selection . . . . .	21-9
Track-Type Tractors . . . . .	21-9
Track Loaders . . . . .	21-9
Landfill Compactors . . . . .	21-10
Wheel Loaders . . . . .	21-10
Hydraulic Excavators (Tracked and Wheeled) . . . . .	21-10
Wheel Tractor-Scrapers . . . . .	21-10
Articulated Trucks . . . . .	21-10
Work Tools for Working in Waste Landfill Applications . . . . .	21-10
Machine Selection Factors . . . . .	21-11

Type of Waste and Refuse Densities . . . . .	21-13
Wet Waste . . . . .	21-14
Factors Governing Compaction . . . . .	21-14
Compaction Comparison Estimate . . . . .	21-15
Landfill Estimating . . . . .	21-16
Example Problems . . . . .	21-16

## APPLICATIONS

Green Waste/Composting . . . . .	21-18
Waste Related Energy Production . . . . .	21-18
Landfills — Renewable Power with Landfill Gas . . . . .	21-18

## TRACK-TYPE TRACTORS

Features . . . . .	21-19
Specifications . . . . .	21-20
Blade Specifications . . . . .	21-25

## TRACK LOADERS

Features . . . . .	21-27
Specifications . . . . .	21-28
Attachments . . . . .	21-29

## LANDFILL COMPACTORS

Features . . . . .	21-30
Specifications . . . . .	21-31
Blade Specifications . . . . .	21-34

## WHEEL LOADERS

Features . . . . .	21-35
Specifications . . . . .	21-36

## APPLICATIONS

Work Tools . . . . .	21-46
----------------------	-------

## INTRODUCTION

An increasing volume of refuse is generated by every person, household, commercial and industrial, entity day after day ... 365 days a year. Disposal of this waste is a major concern worldwide. Increased governmental regulations designed to protect the environment along with rising transportation and land acquisition costs dictate that customers need to be cost conscience. Waste applications are very demanding and are a significant user of earthmoving and specialty mobile equipment, parts, and service. Caterpillar has Waste Specialists in each of the below categories. If you have questions, please contact your local dealer, Waste representative, or go to *Cat.com*.

## SAFETY

Waste industry operators work in some of the world's harshest conditions, so Caterpillar has developed a range of safety resources to help your organization build a culture that delivers everyone SAFELY HOME. EVERYONE. EVERYDAY.™ Caterpillar Safety Services offers training programs, safety checklists, Toolbox Talks, videos, virtual walk arounds and other resources specific to the waste industry at *safety.cat.com*. Click on the Industry Safety tab, and then select Waste.

## OVERVIEW

Waste applications are some of the harshest environments that machines and operators will work in. By definition waste is any discarded, rejected, abandoned, unwanted or surplus material.

The Waste Stream — It is important to understand the type of material you are working with when trying to spec a work tool and machine. Through many site assessments and machine productivity/competitive testing, we have found one underlying theme, the type of waste stream and site conditions, will dictate the type of work, tool, and machine. Residential waste (MSW), construction and demolition (C&D), green waste, commercial waste, wet waste\*, industrials and sludges, auto fluff/car shred, etc., are just some of the types of waste that are dealt with daily. Each type of waste has different characteristics and properties. Weights of these materials could be as low as 148 kg/m<sup>3</sup> (250 lb/yd<sup>3</sup>) to over 1187 kg/m<sup>3</sup> (2000 lb/yd<sup>3</sup>) (sludges and soils). For example, during a recovering/recycling application, your work tool **Fill Factor** could be as high as **150–200%** when dealing with some MSW and shredded C&D.

## MATERIAL RECOVERY FACILITIES, SORTING, AND TRANSFER STATIONS

### Safety

MRF's, Sorting and Transfer Stations are not only harsh but busy environments. Inbound loads, mobile equipment, tip floor personnel, and outbound loads, are only a part of the traffic and dynamics dealt with minute by minute in very close settings. Proper PPE (personal protective equipment) for people, guarding for machines, and safety equipment on machines, are essential to keep safe.

### Technology

Due to the demanding type of applications within MRF's, Sorting and Transfer Stations, machine technology has to lead the way in offering the ability to: scale loads, manage fuel and machine utilization, keep tire wear to a minimum, and help the operator with visual safety front and rear. Eco Modes on machines allow the ability to switch to a fuel saving mode. Product Link™ helps with tracking fuel burn, machine idle time and utilization. Traction control enables the operator to keep tire wear to a minimum.

### Overview: Changing Attitudes in Waste Applications

MRF's (material recovery facilities) sorting, and transfer stations are becoming an important part of the waste industry. Diversion of waste from landfills is a global trend. The European Union, (EU), Canada, Japan, are just a few of the countries who divert 50–75% of their waste stream away from landfills. Cardboard, plastics, paper, food and green wastes are recovered, recycled, or composted. Major changes in the waste stream dictate different methods to gain density. The old mantra of "4–5 passes is enough," now becomes 4–7 passes so that materials can be shredded and bound together for higher densities. The U.S.A. is following this trend as regulations become stricter and the costs of siting/building landfills become higher. Transfer stations become a necessity as disposal sites continue to decline and/or move further away from city centers. MRF's, Sorting/Recycling and Transfer Stations all help reduce primary road and landfill traffic which helps create a safer environment for all.

\*Wet Waste — Several country's, regions, and areas globally have concerns with waste that has a high moisture content. If you or your customer are working with a 'higher moisture content' type of waste, please see the *Wet Waste* section under *Landfills — Types of Waste and Refuse Densities*.

**Primary Roles**

- MRF's (Material Recovery Facilities) Sorting and Recycling Stations are designed to divert recyclable materials from the waste stream. Depending on whether the material is single stream, co-mingled, or pre-sorted, the goal is to divert recyclable material for re-consumption thus lowering the amount of waste placed in a landfill. The natural life of the landfill will be extended by this action. Additional savings of hauling costs can be realized by recovering/recycling materials close to the source (at the MRF or Transfer Station).
- Transfer stations, are designed to consolidate the loads of several residential vehicles in to long-haul vehicles such as rail cars, transfer trailers, barges, and ISO containers. On an average 2–5 inbound loads or more (depending on method of haul) can be consolidated into one outbound load. As a result, transfer stations offer cost savings over direct haul to landfills.

**MRF's (Material Recovery Facilities),  
Sorting Stations, Recycling Stations**

A well-coordinated recycling program will reduce volume going to the landfill by 50% or more. Trends are towards sorting and 1 of 2 types of MRF's.

- Dirty MRF — A dirty MRF accepts mixed waste, (normal household waste that has not been separated) that later may be sorted for recycling. Recoverable/recyclable materials are sorted either by hand or automation or a combination of the two. The materials are either baled and/or are hauled to a plant/industry that will utilize the recovered goods.
- Clean MRF — A clean MRF accepts source separated materials from residential or commercial sources. These are normally delivered in separate collection vehicles. As in the 'dirty' MRF, materials are either sorted by hand, automation, or a combination of both, baled and/or are taken to someplace that will recycle or utilize the recovered goods.
- Sorting Stations — Some transfer stations are designed for some waste diversion from mixed streams and are normally described as 'sorting stations.'

**MRF's, Sorting and Transfer Stations Applications**

There is a wide range of variability in MRF, Sorting and Transfer Station applications and operations. Depending on facility size, amount of material handled, type of station, etc. a wide variety of mobile equipment could be utilized.

In all the facilities mentioned above, materials are tipped by residential or commercial vehicles on to a tip platform or tip floor area. The materials are stockpiled then loaded into hoppers, conveyors, or a haul vehicle. Wheel loaders and excavators (tracked or wheeled) are the primary equipment for stockpiling, loading, sorting, topping off loads, and 'tamping' material into the haul vehicles.

"Volumetric consolidation of material" (normally in Transfer Station applications) is a method of compression and shredding that helps reduce the size of the waste loaded into a haul vehicle. It helps maximize the allowable weight carried by each haul unit. Common machines used for material consolidation are, track-type tractors, track loaders and compactors. These machines are equipped with track shoes or tips/teeth that help in shredding, compression, and reduction of the volume of waste. In most instances, machines performing the material consolidation/reduction are aided by a wheel loader or excavator.

For all applications within MRF's, Sorting, Recycling, and Transfer Stations, there is normally support equipment aiding the primary equipment. Small and compact loaders and excavators, backhoe loaders, skid steer loaders, and fork lifts, are just a few of these machines being utilized.

### **Types of Transfer Stations**

Globally, top loading and compaction transfer stations are the two most popular designs. There are many different types of transfer stations, but, most conform to these two designs.

Top loading systems are the most common and simplest to operate. In top loading designs, there are normally five types of loading arrangements: direct, surge pit, full separation, half separation, and same level or floor loading. Depending on the type of transfer station, wheel loaders, excavators (tracked or wheeled), dozers, track loaders, and compactors can be utilized alone or in systems providing quick efficient waste handling.

Compaction transfer stations utilize hydraulic compaction equipment prior to or during the loading of the haul vehicle to compress the material into bales/logs or into the haul vehicle itself. The hydraulic compactor can be top loaded or side loaded by wheel loaders or excavators, depending on the type of design.

### **EQUIPMENT SELECTION**

In waste applications, the largest single cost in daily operations is purchasing, operating, and maintaining the equipment that will handle the waste. Undersized, inadequate, or unreliable equipment results in inefficient operation and higher maintenance and fuel costs. As in many Cat® applications/industries, right sizing equipment should follow the familiar path of; Task, Tool, Machine. **TASK:** Understand the task or application the machine will work in. **TOOL:** What tool or tools will aid the machine in performing the task most efficiently? **MACHINE:** After finding the 'right tool(s)' to perform the job, then match it to the right sized machine.

Equipment in MRF, Sorting and Transfer Station applications perform the below operations.

1. **Stockpiling the Waste.** Once it is dumped onto the tip floor, wheel loaders, wheeled or tracked excavators, track-type tractors, track loaders, or compactors will push the material up into a stockpile. Stockpiling helps: recover storage and working space within the building, get the waste slightly denser, store the waste till it can be processed or loaded.

Factors for a machine in stockpiling are: type of tool, reach, lift, ceiling height, storage space, and maneuverability.

2. **Recovering and Sorting.** Waste streams are rich in recoverable/recyclable materials. Waste diversion or recovery not only helps reduce the amount of waste going to landfills, but adds to profitability when sold to commodity markets. Sorting and recovery prior to stockpiling or loading can be accomplished with specialized machines equipped with sorting grabs, grapple buckets, or grapples. Stockpiled materials are sorted prior to loading or when loaded with grapples or grapple buckets. All sizes of equipment could be used depending on type of material and material flow. Compact wheel loaders/excavators, skid steer loaders, backhoe loaders, medium wheel loaders and excavators, and telehandlers should be sized according to amount of waste and type of application and type of tool(s) needed. It should be noted that in this type of application couplers on primary and support equipment could be a necessity.
3. **Loading the Waste.** No matter what type of haul/load out, vehicle/conveyor or hopper, materials are either pushed, load and carried, grappled or bucket loaded into transport vehicles or containers. Wheel loaders, tracked or wheeled excavators, track-type tractors, track loaders, compactors or any combination of these (systems) can be utilized. Note that the type of loading application will dictate the type of tool and machine necessary for optimum efficiency in the loading process.
4. **Reducing Volume of Material.** Haul vehicles/transport vehicles need to leave with the maximum allowable weight for the type of transportation mode being used. Wheel loaders and tracked or wheeled excavators can keep stockpiling or turning the waste to get the waste more dense. However, best compression, shredding and volume reduction of the waste is seen by layering waste in thin layers, continuous running over (passes) the waste, turning the waste, and "working" the waste. Track-type tractors, track loaders, and compactors normally see an average of about 60–120 kg/m<sup>3</sup> (100–200 lb/yd<sup>3</sup>) higher density than wheel loaders or excavators in this type of application. Type of track or wheel/tip design is very important for shredding and compression in this type of application.

5. **Support Equipment.** Primary equipment often are supported by machines performing; clean up and sorting with specialized work tools, sweeping with brooms, stacking and loading with pallet forks or bale clamps, etc. Compact wheel loaders and excavators, backhoe loaders, skid steer loaders, and telehandlers equipped specifically for the tasks they need to perform can increase production and efficiency in all areas. Most of the time one or two machines are equipped with couplers to increase their versatility and efficiency helping lower costs.

### Machine Selection Factors

Parameters that could influence tool and machine size, quantity, and possible combinations of machines in MRF's, Sorting and Transfer Stations could include:

1. Amount and type of daily waste to be handled (daily tonnage). During daily inbound tonnage, some peak delivery times occur. It has been found that approximately 50%–60% of inbound tonnages occur on 2–3 “Peak” hours/times of the day. Depending on the inbound tonnage during these times, machines could be spec'd towards these peak times (type and size of facility). What loading platform (top loading/compaction facilities) are they using and how much overall space to work in.
2. Facility load out dynamics.
  - a. Maneuverability
  - b. Ceiling height
  - c. Floor size/storage space
  - d. Floor arrangements
  - e. Type of load out (below grade, ½ separation, same level, surge pit — loading)
  - f. Haul unit specifications
  - g. Inbound/outbound traffic patterns
3. Requirements for volume reduction for higher tonnages in load out.
4. Supplemental tasks performed in daily operations.
5. Budget.
6. Future growth.

**NOTE:** Waste applications place high demands on machinery requiring protection of the machine and its components. Special guarding is needed on all moving parts like axles and drive shafts. Windshields, fuel and hydraulic tanks, radiators, hoses, engine enclosures, are all vulnerable to debris and damage and require guarding. Specially designed debris screens and radiators will ensure clean out and better heat transfer for more efficiency.

### Wheel Loaders

Wheel loaders are normally the primary machine used in MRF's, Sorting and Transfer Stations. Wheel loaders are designed, guarded and built in factory to withstand these harsh environments. Primary operations include: sorting and recovery of materials, push and stockpiling of waste, cleaning floors, support work, and loading conveyors/hoppers/and outbound haul vehicles. Depending on type of material, reach needed, amount of sorting required, ceiling height, floor wear, and type of load out, the machines can be equipped with a wide variety of buckets, attachments and tires. Keeping the thought process of Task, Tool, Machine in mind, a good knowledge of the facility, its waste stream, and type of support work, is needed to ‘right size’ the wheel loader(s) for these applications.

- Compact Wheel Loaders (906–908) — Normally used in small tonnage MRF's/Sorting Stations or as support in larger stations, maneuverability and versatility (coupler equipped) are its main strengths.
- Small Wheel Loaders (924–938) — Used in small–medium MRF's, Sorting and Transfer Stations and as support in larger stations, the small wheel loader brings maneuverability and versatility (coupler equipped) to these types of applications.
- Medium Wheel Loaders (950, 962, 966, 972, 980) — When larger tasks, better reach, higher stockpiling, larger tonnages, etc. are needed, a medium sized wheel loader is normally utilized. These machines have excellent weight to horsepower ratio for better traction and moving larger loads.

The following Wheel Loader Operating Recommendations Chart is an estimate of possible machine(s) for tonnages and type of facility. (Note: Keep in mind the task/application the machine will work in, what tool(s) might accomplish the tasks and then size the machine.)

**Wheel Loader Operating Recommendations**

Tons per Day Volume	Clean MRF Recovery/Recycling	Dirty MRF/Sorting Station	Waste Transfer Station	C&D MRF	C&D Transfer Station
<b>0-100</b>	906-930	924-930	924-930	930-950	930-950 <sup>b</sup>
<b>100-350</b>	908-930 <sup>a</sup>	924-930 <sup>a</sup>	924-938 <sup>a</sup>	950-966 <sup>d*</sup>	950-966 <sup>d*</sup>
<b>350-500</b>	930-950	930-950 <sup>*</sup>	938-966 <sup>*</sup>	966-980 <sup>a*</sup>	950-966 <sup>d*</sup>
<b>500-1000</b>	930-950 <sup>**</sup>	938-950 <sup>e*</sup>	950-966 <sup>**</sup>	966-980 <sup>*</sup>	950-980 <sup>d*</sup>
<b>1000-1500</b>	938-950 <sup>**</sup>	938-966 <sup>e*</sup>	966-980 <sup>**</sup>	950-980 <sup>d,e*</sup>	966-980 <sup>d,e*</sup>
<b>1500-2000</b>	950-966 <sup>**</sup>	966-980 <sup>e*</sup>	966-980 <sup>d,e*</sup>	950-980 <sup>e*</sup>	966-980 <sup>d,e*</sup>
<b>2000-2500</b>	950-966 <sup>**</sup>	966-980 <sup>d,e*</sup>	966-980 <sup>d,e*</sup>	950-980 <sup>e*</sup>	966-980 <sup>d,e*</sup>
<b>2500-3000</b>	950-966 <sup>**</sup>	966-980 <sup>e*</sup>	966-980 <sup>**</sup>	950-980 <sup>e*</sup>	966-980 <sup>d*</sup>
<b>3000 Plus</b>	966-980 <sup>**</sup>	980 <sup>e</sup>	980 <sup>e</sup>	980 <sup>e</sup>	980 <sup>d,e</sup>

C&D = Construction and Demolition

\*Depending on inbound/outbound tonnage, reach, production required, this machine could step up to either a 962 or 972.

- a = Multiple machines recommended (contact your local Cat dealership for recommendations)
- b = Depends on type and density of C&D material
- c = Waste stream mixture may require multiple machines
- d = Operating hours may require additional machines
- e = Multiple machines required

The above are rule of thumb estimates. Your application might vary enough to change the machine for the above recommendations.

Other questions that might need answered are:

- What are you loading? Conveyors, haul vehicles, hoppers, etc.?
- If loading conveyors or drums — what are the feed capacities, FPS rate?
- How much storage capability in your building?
- What type of loading are you performing?
- How much reach is required for stockpiling and loading?
- “Other” required operations that the machine might perform?

**Additional Considerations**

All facilities are different and require special considerations when ordering and specifying tools and equipment. If tonnage and operating hours change, then tool and machine might change. Machine weight has to balance power to ground for best traction on slick floors. Keep in mind Task, Tool, Machine. (What type of work will the machine be asked to perform during the shift? What tool(s) will apply to that type of work cycle? What machine fits to that type of tool?)

It should be noted that most of the wheel loaders being sold into MRF, Sorting and Transfer Stations are high lift. This arrangement offers increased reach and lift height not only for loading and stockpiling, but in case the haul vehicle has to be brought to the same level as the machine to be loaded.



### Hydraulic Excavators (Tracked and Wheeled)

Hydraulic excavators (tracked and wheeled) are often found in MRF, Sorting and Transfer stations either as a primary or secondary tool for loading haul vehicles/conveyors/hoppers, tamping and finishing off loads, and sorting materials. Fast cycle times are the primary advantage of an Excavator over a Wheel Loader. Wheeled excavators come with a maneuverability advantage especially in tight loading and stockpiling areas. Depending on the type of application, tracked and wheeled excavators would be equipped either for high production loading/compaction, or with sorting/separating tools for recovery of recyclable materials.

Again, keeping the Task, Tool, Machine concept in mind, you should take into account the following when sizing a tracked or wheeled excavator. Type of material and density, tonnage, work load for the machine, ceiling height, work area/swing area, floor size, along with maneuverability needed, ability to 'see' into haul vehicles or down into the floor load out area (cab risers), and reach. Special guarding packages, radiators, and reversing fans are options that may be needed to meet the most demanding needs.

### Track-Type Tractors

Waste Handling Track-Type Tractors are designed, guarded, and built in factory so that they can accommodate all waste applications. Although its primary use is for pushing and layering the waste and cover materials in landfills they offer alternative waste movement and volume reduction in large transfer stations and C&D transfer stations. Ex: In surge pit operations where waste is tipped into a level below the tipping floor. Track-type tractors will push, layer, and compress/shred the material during operations and push into a haul vehicle. This method is used when maximum volume reduction is required or peak rate of waste exceeds available floor space.

### Track Loaders

Waste Handling Track Loaders are designed, guarded, and built in factory so that they can accommodate all waste applications. Transfer stations are a strength for this machine due to its versatility in this application. Sorting, pushing, layering, and compaction are all part of typical operations within the transfer station application. Just like the track-type tractor, the track loader is used in higher tonnage transfer stations, C&D transfer stations, and when waste needs volume reduction. Equipped with a multi-purpose bucket, the track loader can sort, push, layer, compress and shred, and load material into outbound haul vehicles.

### Landfill Compactors

Although landfill compactors are designed for spreading and compacting large volumes of material in a landfill environment, in some instances, transfer stations might have a large enough working area to allow the compactor to be utilized to reduce waste volume prior to loading into haul vehicles. They offer two advantages in this type of application.

1. They are configured and guarded to work in this type of environment.
2. They achieve higher compression, shredding, and compaction levels compared to other machines.

**CAUTION!** Operating a landfill compactor, track-type tractor, or track loader on a concrete floor could be counterproductive due to floor wear and maintenance costs. Always keep a layer of waste between the floor and machine until final movement of the day. Wheel loaders and/or excavators (wheeled/tracked) should be used to support these machines. (Please see #4 under previous Equipment Selection.) (It is not recommended to use a landfill compactor larger than the 826.)

### Work Tools for Material Recovery Facilities, Sorting and Transfer Stations

As described in the opening statements of this section, the waste stream can consist of many different types of materials sometimes all blended together. For that reason, work tools become a very important part of moving, sorting, and dozing in waste applications.

At the end of this section, there will be a Work Tool section and chart discussing possible tools to use. Please contact your dealer/regional waste representative for more information.



**LANDFILLS****Safety**

Landfills are harsh and busy environments. A variety of vehicle traffic on haul roads, busy tipping areas, people on the tip floor, a large variety of different types of waste, mobile heavy equipment operations, special waste haulers, etc. are all part of the dynamics of a landfill working face. Proper PPE (personal protective equipment) for people, guarding for machines, proper training, and safety equipment on machines, are essential for a safe work environment.

**Technology**

Due to the demanding environment and its possible applications, machine technology has to lead the way in offering the ability to: manage fuel and machine utilization, keep undercarriage cost to a minimum, and help the operator with visual safety front and rear. Eco Modes on machines allow the ability to switch to a fuel saving mode. Product Link helps with tracking fuel burn, machine idle time and utilization. Computers, VIMS™ (Vital Information Management Systems,) and Traction Control (in some track-type tractors) helps operators control spin and keep track of mileage to help decrease undercarriage wear.

**Landfill Overview: Landfilling Now and in the Future**

Although recovering and recycling materials is becoming more prevalent, landfilling still provides a place to deposit waste materials or refuse not able to be recovered/recycled. A landfill protects the environment by disposing of the waste in an engineered cell. Siting, designing, building, and operating a landfill is costly. Depending on country, state, region, etc., landfills have to design and operate to very strict regulations. Proper equipment selection and daily operating techniques can maximize and extend the operational life of the landfill along with lowering costs.

Primary types of landfills are MSW (municipal solid waste/residential), C&D (construction and demolition), and Hazardous (hazardous industrial sludges, asbestos, etc.) with the majority of landfills being MSW or residential waste. Landfills can take in many different types of materials and will range from less than 90 metric tons/day (100 tons/day) to over 13 610 metric tons/day (15,000 tons/day). Depending on the country you live in and its regulations on recycling, the waste stream going to the landfill could be a mix of food wastes, packaging, plastics, cardboard/paper, metals, C&D, etc. In some highly regulated countries, food wastes, plastics, cardboard/paper, metals, and C&D, are diverted to C&D landfills, composting sites, and/or facilities that will recycle the recovered product.

In keeping with environmental concerns, most landfills have a highly engineered method of dealing with leachate, gas, and inbound waste. (See the *Caterpillar Equipment and Application Guide — Waste Landfills* or your countries Environmental Landfill sites.) Once cell, leachate, and gas methane extraction development are in place, the basics are to: push, layer, compact the waste in thin layers, adding daily cover or ADC (alternative daily cover) sparingly. The idea is to fill the landfill with as much waste as possible without robbing airspace by using too much cover soil.

Future. Diversion rates of recoverable materials within the EU Canada, some Asia Pacific countries, and starting in the U.S. will eventually reach 60%–80% diversion or more. This will all depend upon commodity markets and the demand for the recycled materials. It also drastically changes the waste stream going to the landfill. The type of waste going to a landfill from a good diversion plan is normally light plastics, packaging, hard to handle materials, metals and materials that can't be recycled. This waste stream might require different handling, processing, amount of passes, and compaction techniques to shred and compress it as much as possible and possibly different wheel tips and tip patterns. (See text in *Factors Governing Compaction —Developing a Pattern and Running Proper Passes.*)

## EQUIPMENT SELECTION

A landfill's largest single cost for daily operations is purchasing, operating, and maintaining its mobile equipment fleet. Undersized, inadequate or unreliable equipment results in low machine utilization, higher fuel and maintenance costs and eventually improper landfill operations.

Landfill equipment performs three major distinct functions:

1. **Waste disposal:** Which includes, pushing, spreading, and compaction. Track-type tractors, track loaders, and landfill compactors are primary machines in this application.
2. **Cover material mining and application:** Machines will provide daily cover requirements whether cover soil or ADC (alternative daily cover). If supplying cover material is a machine's sole function, then it can be selected on the same criteria as normal earthmoving. Distance to borrow pit, material characteristics, volume to transport, production needs, underfoot conditions, etc. are all important in right sizing the equipment. Lowest cost is determined by best efficiency and lowest cost/m<sup>3</sup> (yd<sup>3</sup>).
3. **Support activities:** What 'other' roles might the equipment be asked to accomplish or what support is needed for the primary equipment? Water trucks to keep dust down, motor graders to maintain haul roads, wheel loaders/excavators/backhoes/skid steer loaders, telehandlers, etc., with couplers that can utilize all types of work tools, generators, service vehicles, air compressors, etc. are all necessary equipment to keep the landfill running efficiently.
4. **Peak periods:** Most landfills have to deal with 2–4 periods during the day where more volume of waste is delivered by more inbound vehicles than normal. These are called peak periods. Depending on the size of the landfill and amount of peak waste coming in, it should be noted that some landfill equipment can or should be specified in order to handle these peak times of waste and vehicles.

There are many variables when choosing the "right" sized equipment for landfill use. Again, we point to the direction of thinking: Task, Tool, and Machine. What are the application, production, compaction, support requirements? What tool or tools can accomplish this task? And finally, what machine(s) will handle the tool(s) most efficiently? (To help with 'right sizing' a compactor and/or track-type tractor together, Waste Fleet Analysis/WFA (downloaded at *Dealer.Cat.com*) can be utilized as a rule of thumb to determine possible compactors/track-type tractors and combinations of the two.)

### Track-Type Tractors

Waste Handling Track-Type Tractors are designed, guarded, and built in factory so that they can accommodate all waste applications. The track-type tractor is the most popular machine on the landfill. They prepare the site, build haul roads, push/spread/and sometimes compact the refuse, spread cover material, and perform a variety of support functions. Quantity of material to be moved/hr., type of inbound delivery vehicles, distance of push, support work needed, etc., all should be taken into consideration when sizing a track-type tractor for its application. Economic distances for dozing waste or cover soil efficiently is no more than 90 m (300 ft) or less. The track-type tractor, when used to compact, can achieve densities of approximately 475–590 kg/m<sup>3</sup> (800–1000 lb/yd<sup>3</sup>) (MSW, 3:1 or less slope, multiple passes).

### Track Loaders

Waste Handling Track Loaders are designed, guarded, and built in factory so that they can accommodate all waste applications. These machines are highly versatile and perform many primary and support activities. They can be used in any size landfill and are ideal for landfills under 135 metric tons (150 tons) since they can work solo to perform waste handling and cover material functions. Equipping the machine with a coupler or a multi-purpose bucket increases its versatility. The multi-purpose bucket can be used for pushing waste, sorting materials, and dozing cover soils. The machine can be equipped with different track options from double to single grouser allowing it to work in normal operations or be utilized to more aggressively shred materials (Heavy MSW or C&D). Utilizing correct methods of compaction, (spread thin and load the bucket with soils to increase weight) will achieve higher densities during compaction. Compaction densities can range from 475–590 kg/m<sup>3</sup> (800–1000 lb/yd<sup>3</sup>).

**Landfill Compactors**

Landfill Compactors are specifically designed, built, and guarded in the factory to effectively shred and compress large volumes of waste. Depending on landfill size and amount of tons inbound daily, the compactor will work solo (pushing, spreading, compacting) handling all the inbound waste, or work in tandem with a track-type tractor (track-type tractor — push/spread, compactor — shred/compact). When working the track-type tractor and landfill compactor together as a “system,” productivity and compaction densities will increase. Depending on the type of waste stream to be compacted, initial waste density, depth of the layer spread, and size/weight of the landfill compactor, compaction densities can be 593–1100 kg/m<sup>3</sup> (1000–1854 lb/yd<sup>3</sup>). Although the compactor can work on steeper slopes, best slopes for highest density for landfill compactors are 4:1 or less.

**Wheel Loaders**

Wheel loaders are designed, guarded and built in factory to withstand these harsh environments. Not recommended as a compaction machine, wheel loaders are mobile and versatile and sometimes are used by communities sharing a single machine which can travel and support community/landfill projects. Wheel loaders are normally equipped with a coupler and many different tools to make it more versatile. Loading cover soils, sorting, clean up, spreading road material, and handling leachate/gas pipes are just a few of the activities wheel loaders perform in landfill applications.

**Hydraulic Excavators (Tracked/Wheeled)**

Every landfill has a tracked or wheeled excavator supporting its operations. Whether equipped with a coupler, which accommodates multiple tools, or a pinned attachment, wheeled and tracked excavators offer superior versatility in: cell development, cover soil mining, ditch/pond clean out, and leachate and gas extraction support. Wheeled excavators give you mobility and maneuverability along with the ability to be able to respond quickly to support needs. When loading cover materials is the primary application, it is critical to know the size of the haul vehicle, type of material, and production required, so as to define the proper size bucket, stick, and finally machine to meet production needs.

**Wheel Tractor-Scrapers**

Wheel tractor-scrappers mainly perform cover soil operations. Wheel tractor-scrappers work in site preparation, cell construction and hauling/placing cover material. When underfoot conditions are good and the haul over 185 m (600 ft) the wheel tractor-scraper will be economical. The machine should be selected as if performing a typical earthmoving application. Average sized landfills prefer the work alone capability of either an elevating or twin engine scraper since they are self-loading machines. Larger landfills sometimes utilize larger push-pull scraper units to meet their daily cover soil production needs. Preferably, the scraper unloads the cover material close to the working face where track-type tractors or track loaders can push and spread the material in the required layer depth. This will reduce tire damage and extra maintenance costs to the machine.

**Articulated Trucks**

Articulated trucks are versatile, highly maneuverable, all weather haulers that can negotiate poor underfoot conditions. Like wheel tractor-scrappers, articulated trucks work in site preparation, cell construction, and hauling/placing cover material. Articulated trucks are normally loaded by a variety of loading tools and economically effective with hauls from 0.2 km–5 km (600 ft–3 miles). In dump configuration, cover material is dumped close to the work face and spread by a supporting track-type tractor or track loader. Ejector configured trucks are preferred and provide safer on-the-go dumping in normal to softer more sloped ground conditions where a “dump configuration” machine would not be suitable. Cat articulated trucks offer optional container handling and refuse body configurations for specialized landfill applications.

**Work Tools for Working in  
Waste Landfill Applications**

As described in the opening statements of this section, the waste stream can consist of many different types of materials sometimes all blended together. For that reason, work tools become a very important part of moving, sorting, and dozing in waste applications.

At the end of this section, there will be a Work Tool section and chart discussing possible tools to use. Please contact your dealer/regional waste representative for more information.

### Machine Selection Factors

Selecting the type, size, quantity, and combination of machines required to spread, compact, and cover varying daily refuse volumes is determined by the following parameters:

1. Amount and type of waste to be handled (daily tonnage) (peak periods should be charted and reviewed and taken into considerations)
  2. Amount and type of cover material to be handled
  3. Distance cover material to be transported
  4. Compaction/density requirements
  5. Weather conditions
  6. Supplemental tasks
  7. Budget
  8. Growth
- A. Daily tonnage and peak periods — Amount of waste produced by a community is the major variable in selecting the appropriate sized machine. The following chart serves as a “guideline” in sizing a landfill machine. For example, if a community generates approximately 180 metric tons (200 tons) of refuse per day, a D6, 953, and/or an 816F2 landfill compactor could be considered. Depending on the tonnage, type of waste, and peak periods, multiple machines or a ‘system’ of machines (ex: 836K and D8T) could be considered. As discussed earlier, peak periods during the day, (periods of time where a higher than normal average amount of waste comes in) could dictate what size machine is needed to keep up with the inbound waste. During these times, another machine could be added to the mix until the waste is layered and compacted correctly.
- B. Amount and type of cover material to be handled — Landfill, size, type, and methods of operation vary dramatically from site to site. The type and amount of cover material utilized is important. The use of Alternative Daily Cover (ADC) is highly recommended to reduce loss of valuable airspace. Landfill managers track cover material use as close as they track their airspace and maintenance. The use of cover material is broken down into three segments: daily, intermediate, and final. Landfill operators agree that daily cover should be no more than 10% or less of the entire lift. No matter how much daily or intermediate cover is used, the growing trend is to remove or ‘mine’ cover material prior to beginning the daily operation in that area. The total combination of daily and intermediate cover if not removed, could end up being more than 25%–35% of total landfill airspace loss. Removal of cover material increases airspace and helps facilitate leachate and gas migration.

Blade/bucket design is paramount if a machine is used specifically for working with cover soil. Straight blades, Semi U blades, and multi-purpose buckets are primarily used by track-type tractors and track loaders. With the need to carry and layer cover material to an exacting maximum, blades/buckets that can shed material easily are recommended. If the machine will be used in waste and cover soil operations, then a Semi Universal blade (for load and carry) and the multi-purpose bucket are good recommendations.

- C. Distance cover material is to be transported — Whether working with daily, intermediate, or final cover, the following guidelines are recommended for cover material movement. Quantity of material to be moved, required production, and maintenance results, must also be considered when using these guidelines.

Track-type tractor	0-61 m (0-200 ft)
Track loader	
Push/spread	0-61 m (0-200 ft)
Load & Carry/spread	0-150 m (0-500 ft)
	(Type of material/application needs to be considered for possible excessive track wear)
Wheel loader	0-185 m (0-600 ft)
Wheel tractor-scraper	over 185 m (over 600 ft)
Articulated truck	over 185 m (over 600 ft)
	(Haul distance, road and borrow pit conditions, weather, tip area dynamics — all need to be taken into consideration when making a decision to use a scraper or articulated truck)

- D. Compaction requirements — Best utilization of airspace is critical to extending landfill life. Quantity and type of material, work face variables, operator skill, operating hours, size and type of equipment, etc., all play a part in achieving high densities. Highest density is gained by utilizing a ‘system’ approach of machines (track-type tractor pushing and spreading — compactor leveling and compacting) or to a lesser extent, just using a compactor.

The following product segments of this section will contain features, specifications, and work tools for primary Cat Waste Handling machines. Additional drawbar/rim-pull vs. groundspeed charts, ground pressures, controls, production estimating tools, information, can be found in respective product sections within this *Performance Handbook*.

The below *Machine Tonnage and Usage Selection Factor Guide* should be considered a ‘rule of thumb.’

To use; find the amount of tonnage/day that the landfill takes in (left column) — to the right of that column find the possible machines that could be used for that amount of tonnage (marked by an ×). Please note that depending on the type of waste, amount of waste/day, and even amount of waste/hr., a single machine could be utilized or multiple machines might be necessary.

*For example:* Follow the left column down to 45.3 to 136 Metric Tons/day (50 to 150 tons per day) — For MSW Landfills — All the machines marked by ×’s could be utilized. Smaller machines for smaller tonnages, larger machines for larger tonnages. Depending on budget and required density, and required support activity, a single machine might be used or a combination of machines could be needed.

<b>Machine Tonnage and Usage Selection Guide</b>	<b>D6N</b>	<b>D6T</b>	<b>D7E</b>	<b>D8T</b>	<b>D9T</b>	<b>953</b>	<b>963</b>	<b>973</b>	<b>816F2</b>	<b>826K</b>	<b>836K</b>
<b>0 to 45.3 Metric Tons per Day (0 to 50 Tons per Day)</b>											
MSW Landfills	×	×				×	×				
Construction and Demolition Landfills/Other		×	×				×	×			
<b>45.3 to 136 Metric Tons per Day (50 to 150 Tons per Day)</b>											
MSW Landfills	×	×				×	×		×		
Construction and Demolition Landfills/Other		×	×				×	×	×	×	
<b>136 to 227 Metric Tons per Day (150 to 250 Tons per Day)</b>											
MSW Landfills	×	×				×	×	×	×	×	
Construction and Demolition Landfills/Other		×	×	×			×	×	×	×	
<b>227 to 317.5 Metric Tons per Day (250 to 350 Tons per Day)</b>											
MSW Landfills		×	×	×			×	×	×	×	
Construction and Demolition Landfills/Other			×	×				×		×	
<b>317.5 to 453.6 Metric Tons per Day (350 to 500 Tons per Day)</b>											
MSW Landfills		×	×	×			×	×		×	×
Construction and Demolition Landfills			×	×	×			×		×	×
<b>453.6 to 680.4 Metric Tons per Day (500 to 750 Tons per Day)</b>											
MSW Landfills			×	×			×	×		×	×
Construction and Demolition Landfills/Other			×	×	×			×		×	×
<b>680.4 to 907.2 Metric Tons per Day (750 to 1000 Tons per Day)</b>											
MSW Landfills			×	×	×			×			×
Construction and Demolition Landfills/Other			×	×	×			×			×
<b>907.2 to 2721 Metric Tons per Day (1000 to 3000 Tons per Day)*</b>											
MSW Landfills			×	×	×			×			×
Construction and Demolition Landfills/Other			×	×	×			×			×
<b>2721 PLUS Metric Tons per Day (3000 PLUS Tons per Day)*</b>											
MSW Landfills			×	×	×			×			×
Construction and Demolition Landfills/Other				×	×			×			×

\*Might require multiple machines or ‘systems.’ Systems = dozer/compactor combination (S).

**TYPE OF WASTE AND REFUSE DENSITIES**

The type and density of the waste stream inbound to MRF’s, Sorting/Transfer Stations, and Landfills determine how it is handled, the type of work tool, and ultimately the type of machine to handle it. Type of waste to be handled will strongly influence machine selection. The major waste components for the community and landfill should be identified and machine selection based on the type of waste and compaction density required. For example, if the site receives a high proportion of material that is hard to compact like medium to heavy C&D waste, (rocks, bricks, concrete, tree stumps, telephone poles, etc.) a landfill compactor might have a hard time achieving normal densities without the help of a track-type tractor or track loader. Tracked machines have more difficulty pushing and compacting bulk waste such as trees, road materials, iron, etc. A combination or “system” of both tracked machine and landfill compactor might work best. Depending on the type of waste, different tip/cleat designs will help with shredding, traction, and density.

On average, Americans generate approximately 2 kg (4.4 lb) waste/day while the European Union (EU) generates about 1.4 kg (3.0 lb) waste/day. (Before recovery/recycling) Waste composition varies from location to location, the following charts are representative of the waste stream in the U.S. and EU. (Please note that the growing trend within the EU and to a lesser extent the U.S. is to use waste as a resource. Subsequently the numbers represented in these charts will have annual changes.) The EU-27 are avoiding waste to landfills through recovery, recycling, composting, and incineration, and are trying to use waste as a resource. For the EU-27, approximately 38% of waste is landfilled. The U.S. is currently approximately 33% recovered/recycled with a slow trend towards composting.

**2011 EU-27 Total MSW Generation (by material)**

Paper/Cardboard	40.0%
Food Scraps	25.0%
Plastics	19.0%
Metals	6.0%
Wood	15.0%
Glass	20.0%
Shares of packaging waste	<i>Courtesy of EEA</i>

Generally, loose residential and commercial refuse weighs 150–267 kg/m<sup>3</sup> (250–450 lb/yd<sup>3</sup>). A refuse truck will increase this density to 237–593 kg/m<sup>3</sup> (400–1000 lb/yd<sup>3</sup>). Once ejected from the refuse truck, some waste has a ‘rebound’ tendency and it will lose some density. Typically, loose on the landfill, we see loose refuse weights with an average of 207–475 kg/m<sup>3</sup> (350–800 lb/yd<sup>3</sup>). This waste needs to be compacted and in-place densities can vary from between 356–889 kg/m<sup>3</sup> (600–1500 lb/yd<sup>3</sup>) depending on the shredding and compression applied by the compacting machine. C&D landfill sites, depending on type of inbound material, sometimes see a wide range of densities from 593–1187 kg/m<sup>3</sup> (1000–2000 lb/yd<sup>3</sup>) (depending on compacting machine). Cover material will raise fill densities 119–296 kg/m<sup>3</sup> (200–500 lb/yd<sup>3</sup>) from the numbers above. When asked about the density of their landfill, most managers will give you the ‘in-place with cover’ estimates of density — Please see weights of refuse below:

**Weight of Refuse**

	kg/m <sup>3</sup>	lb/yd <sup>3</sup>
Loose Refuse:	148-237	<b>250-400</b>
Packer Truck:	237-474	<b>400-800</b>
Fill Density:	355-949	<b>600-1600</b>
Refuse and Cover:	474-1186	<b>800-2000</b>

**2011 U.S. Total MSW Generation (by material)  
250 million tons (before recycling)**

Paper/Cardboard	28.1%
Food Scraps	14.5%
Yard Trimmings	13.5%
Plastics	12.7%
Metals	8.8%
Rubber, Leather and Textiles	8.2%
Wood	6.4%
Glass	4.6%
Other	3.3%
Before Recycling	<i>Courtesy U.S. EPA</i>

**Wet Waste**

There are a number of global landfills that deal with a heavier than normal amount of ‘wet waste,’ or waste with higher than normal moisture content. In previous discussions, ‘type of waste’ will determine how the waste is handled or worked. With higher than normal moisture contents, the idea of ‘multiple’ passes (3–5) will be changed. For example, the waste will already be heavier/denser than normal (ex: 1186 kg/m<sup>3</sup> or 2000 lb/yd<sup>3</sup>) this type of waste might only require a track-type tractor or track loader to spread it. During the spread cycle, the shredding/tearing action of the track cleats provides an additional density. Or, the compactor could be equipped with a ‘wider’ flotation wheel (optional wheel from Caterpillar) that provides better flotation along with shredding and compression that will add to the density of the waste. Whichever system is used, less passes on the waste are needed to reduce the waste and add to density. (Too many passes could lead to the waste breaking down and causing traction/flotation problems on the landfill.)

**FACTORS GOVERNING COMPACTION**

There are four factors that will determine best compaction density (layer thickness, patterns/passes, slope, and moisture content). The three areas that can be affected most by proper machine applications are:

1. Refuse Layer Thickness — The single most important factor in gaining maximum density is the depth of the layer being spread to compact. Depending on the amount of tips/wheel, type of tips, type of waste, and weight of the machine, optimum layer depth will vary. Through field testing and computer analysis, optimum layer depths for highest density have been analyzed. Below are guidelines of optimum layer depth for each compactor.
  - a. 816 — 0.3–0.4 m (12–15 in)
  - b. 826 — 0.45–0.5 m (18–20 in)
  - c. 836 — 0.5–0.6 m (20–24 in)

Layers may be placed thicker however; density will be reduced no matter how many passes the compactor performs.

Below is a Layer Thickness chart based on MSW and 4 passes by an 836.

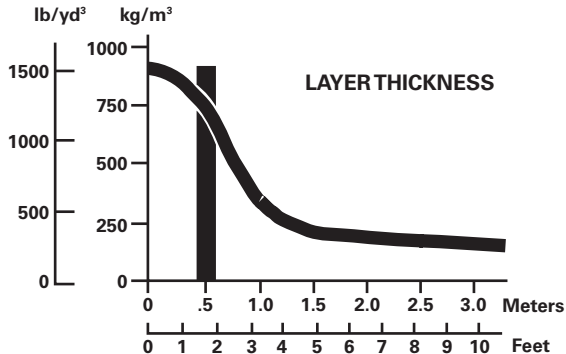

2. Developing a Pattern and Running Proper Passes — Maximum compaction density is obtained by putting the waste down in proper layer height, running a proper pattern and going over the waste with the proper number of passes. Those operators who develop a pattern, (starting from one side of the working face and running passes over entire area that waste has been layered in a logical sequence) and run proper amount of passes, normally obtain high density. In the past, it was said “that 3–5 passes is maximum to achieve highest density. Any more passes does not justify the added fuel and maintenance for the incremental gain in density.” Again, through testing and computer modeling, it has been noted that running an extra 1–2 passes diagonally (45 degrees) over the waste after the first 4 passes, can achieve higher density through ‘shredding and knitting’ the waste together (less cover soil/ADC could also be used due to the blending of the waste). In many countries, the ‘diversion’ of compost and biodegradable materials leaves some waste streams very dry. Drier waste streams demand more passes than normal, (sometimes 5–8 passes,) so that the material can be shredded or broken down properly for best compaction density.

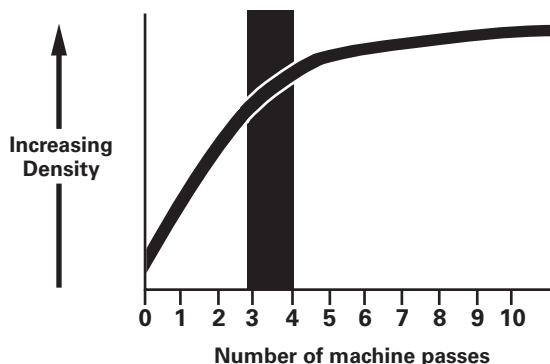

3. Slope — Maximum density is achieved by shredding and compression of material. Track-Type Tractors and Track Loaders achieve highest density on a 3:1 or less slope. The dynamics of track and gravity working together help shred material into smaller pieces. Although Landfill Compactors can work on steeper than 4:1 slopes, their best density is realized at 4:1 or less. The flatter the slope the better the density. The weight of the compactor is more efficiently utilized and concentrated on flatter slopes. Slight slopes sometimes add higher density due to the shearing stress that aids in shredding and blending of materials. Depending on degree of slope and whether working with another machine, (track-type tractor, dozer, or compactor) fuel use can sometimes be better uphill or downhill. Of course production is always better downhill. Again, depending on type of material and slope, tip selection for the compactor should be taken into consideration.

**COMPACTION COMPARISON ESTIMATE**

The following graph may be used as a rule of thumb for the compaction ranges of landfill machines assuming the proper operating technique is employed. (The mid ranges of each graph is assuming average waste stream and average operator.)

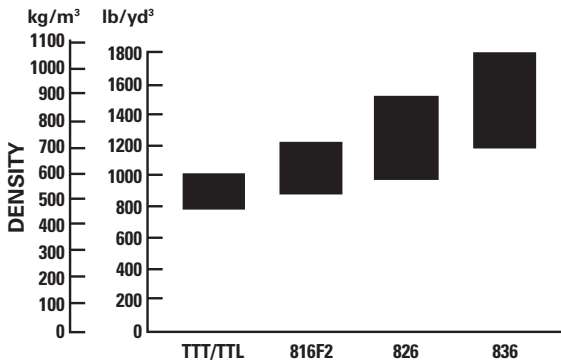

With correct operating procedures, tip/track/tool selection, and finally machine selection, density can be increased. An example of how increased density can increase landfill life is depicted in the next charts.

**EXAMPLE OF INCREASED COMPACTION  
ON POTENTIAL LANDFILL LIFE**

Landfill refuse capacity	1 530 000 m³ (2,000,000 yd³)	
Operating days	260	
Daily volume	365 metric tons (400 tons)	
Yearly volume	94 328 metric tons (104,000 tons)	
Compaction	Landfill Life	Gain
590 kg/m³ 1000 lb/ycd³	9.6 years	0
710 kg/m³ 1200 lb/ycd³	11.5 years	1.9 years
830 kg/m³ 1400 lb/ycd³	13.4 years	3.8 years
950 kg/m³ 1600 lb/ycd³	15.3 years	5.7 years
1070 kg/m³ 1800 lb/ycd³	17.2 years	7.6 years

**COMPACTOR PRODUCTION GUIDELINES**

Model	Metric Tons/hr	U.S. Tons/hr
836K	140	135
826K	120	115
816F2	65	65

Parameters for the above: MSW, 4 passes, 18–30 m (60–100 ft) push distance, 4:1–5:1 slope, good operator.

All models are making 3 to 4 passes.

A pass is defined as: A machine traveling over the refuse one time in one direction on flat ground.

Adverse (uphill) or favorable (downhill) grades, deep layered waste, hard to handle waste, etc., will affect the above production figures.

(For tons/day — multiply by the amount of hours the machine will work in a days time.)

- A. Weather Conditions — Inclement weather affects production and density. Equipping machines with the proper track shoe or wheels and tips for the typical climate it works in will increase production and density while decreasing costs.
- B. Supplemental Tasks — There are a wide variety of tasks to be performed daily on a landfill. Understanding the ‘supplemental’ tasks that a machine might be asked to perform daily is paramount to adding the work tool(s) and right sizing the machine. For example, will the machine be required to perform site clearing, asked to build or maintain access roads, excavate cover soil, etc.? Logical choices of machines could change according to type of tasks and versatility required.
- C. Budget — Smaller landfill operations with limited budgets may have to consider single machine versatility ahead of specialized machines or multiple units.
- D. Growth — Population growth or added contracts can both increase and change inbound refuse. Future increases/decreases in refuse, type of material, density of material, etc., must be considered to properly pick tools and size machines.



## LANDFILL ESTIMATING

### Example Problem #1

A professional engineer has developed a small, rural landfill master plan. The local legislative regulatory agency has approved the plan and site.

Assume:

Waste generation: 2.04 kg/day (4.5 lb/day) per person

Waste collection: 6 days/week

Topography: flat

Land availability:

area has several suitable sites at nominal price

Population served: 30,000

Projected population in 3 years: 40,000

Current daily refuse volume: ?

Type of refuse: mostly household, some commercial

Operation: propose 8 hours/day, 5½ days/week

Present equipment: none — new site

What would your comments and recommendations be on the following:?

- Probable amount of refuse generated daily?
- Type of machine for the proposed Landfill?
- Size of machine for the proposed Landfill?

### Solution

- The current incoming waste stream can be determined to be 2.04 kg/day (4.5 lb/day) per person × 30,000 people = 61.2 metric tons (67.5 tons) daily. You must now multiply that daily generation rate by 7 for the total weekly generation, and divide by the number of days that the waste is collected (6). Therefore, your waste collection per day will be (61.2 tons/day × 7 days)/6 days of collection = 71.4 metric tons (78.7 tons) collected daily.

The same equation can be used to determine the three year projected waste stream of 40,000 residents to be 81.6 metric tons (90 tons) generated daily, 95.2 metric tons (105 tons) collected each day.

- Track loader — excavating ability, single machine application based on tonnage requirements.
- 953C handle current refuse, and has extra capacity for future growth. Small compactor if additional compaction is required.

### Example Problem #2

Existing landfill has been in operation for several years.

Assume:

Type of operation: area fill

Cover material: suitable material within 90 m (300 ft)

Current daily refuse volume: 500 metric tons (550 tons)

Anticipated daily refuse volume in 3 years:

680 metric tons (750 tons)

Type of refuse: household, commercial, large amount of brush and building demolition debris

Land availability: limited, very expensive

Available Refuse Volume: 3 249 125 m<sup>3</sup> (4,250,000 yd<sup>3</sup>)

Operation: 8 hours/days, 5½ days/week

Present equipment: D8 (3 years old)

What would your comments and recommendations be on the following:

- What range of in-place densities could be expected using a track-type tractor; a Cat steel wheeled landfill compactor?
- What effect does machine selection have on site life?
- What are the advantages and limitations of steel wheeled landfill compactors?
- What are the advantages and limitations of track-type units?
- How many machines should be used on the site?
- What type should they be?
- What size should they be?

Solution

- a. The Track-Type Tractor will achieve 475 to 595 kg/m<sup>3</sup> (800 to 1000 lb/yd<sup>3</sup>) in-place density. The Cat steel wheeled landfill compactor will achieve 595 to 830 kg/m<sup>3</sup> (1000 to 1400 lb/yd<sup>3</sup>) in-place density.
- b. There are 3 249 125 m<sup>3</sup> (4,250,000 yd<sup>3</sup>) available. 500 metric tons (550 tons) per day is how many m<sup>3</sup> (yd<sup>3</sup>)? Assume a minimum density of 475 kg/m<sup>3</sup> (800 lb/yd<sup>3</sup>).

$$500 \text{ metric tons/day} \times \frac{1000 \text{ kg/metric ton}}{475 \text{ kg/m}^3} = 1052 \text{ m}^3/\text{day}$$

$$550 \text{ tons/day} \times \frac{2000 \text{ lb/ton}}{800 \text{ lb/yd}^3} = 1375 \text{ yd}^3/\text{day}$$

$$5.5 \text{ days/week} \times 52 \text{ weeks/year} = 286 \text{ days/year}$$

$$\text{Yearly volume: } 1052 \times 286 = 300\,872 \text{ m}^3$$

$$1375 \times 286 = 393,250 \text{ yd}^3$$

Landfill life at this density:

$$\frac{3\,250\,000 \text{ m}^3}{300\,872 \text{ m}^3/\text{year}} = \frac{4,250,000 \text{ yd}^3}{393,250 \text{ yd}^3/\text{year}} = 10.8 \text{ years}$$

Similar calculations are performed to generate the following tables.

**500 METRIC TONS/DAY (550 TONS/DAY)**

Density		Landfill Life (years)
kg/m <sup>3</sup>	lb/yd <sup>3</sup>	
475	800	10.8
595	1000	13.5
715	1200	16.2
835	1400	18.9
950	1600	21.6

**680 METRIC TONS/DAY (750 TONS/DAY)**

Density		Landfill Life (years)
kg/m <sup>3</sup>	lb/yd <sup>3</sup>	
475	800	7.9
595	1000	9.9
715	1200	11.9
835	1400	13.9
950	1600	15.9

From the tables we determine that a track-type tractor, at 500 metric tons per day (550 tons/day), will provide 13.5 landfill life years at 595 kg/m<sup>3</sup> (1000 lb/yd<sup>3</sup>). Compaction will extend that life 5.4 years to 18.9 years at 835 kg/m<sup>3</sup> (1400 lb/yd<sup>3</sup>).

Proper compaction techniques are necessary to achieve the higher refuse densities and increase landfill life.

- c. Advantages: Provides highest compaction densities extending landfill life.

Limitations: Specialty unit designed to spread and compact — does not excavate virgin material economically, but can handle stockpile cover material.

- d. Advantages: most versatile unit, well suited to site preparation, finishing and access road construction and maintenance; all weather machines with excellent tractive ability.

Limitation: compaction — cannot achieve the in-place refuse densities of the specialized landfill compactors.

- e. Minimum of two. Additional equipment would depend on supplemental tasks.
- f. Track-type tractor — for earthmoving and refuse spreading work; steel wheeled compactor-quantity of refuse and land cost would justify.
- g. D8 — keeping existing unit; D9 — when new tractor is necessary; 826H — with large amount of demolition debris and brush and projected increase in tonnage would justify 826H over 816F2.

**NOTE:** Ballasting the wheels on Cat Landfill Compactors to increase machine weight and achieve higher compaction densities is not recommended. Landfills are high rimpull applications. Ballasting the wheels will significantly increase machine weight but decrease overall performance when traveling on the fill. The additional weight of ballasted wheels will also result in reduced final drive life.

## **GREEN WASTE/COMPOSTING**

Green waste and compostable material are being eliminated from most landfills. Composting is normally regulated at the state level in the U.S., and on higher governmental levels within the EU. Green and compostable waste is realized as: soil amendments, bio fuels, and incinerated energy sources. With more and more green waste and compostable material being diverted from the waste stream, tools and machines that can handle this type of waste are needed. Most commonly used are wheel loaders and excavators (wheeled/tracked) of all sizes. Most are equipped with coupler for versatility of different tools. Work tools utilized range from grapple buckets, multi-purpose buckets, and light material buckets for wheel loaders, to waste grapples, orange peel grapples, and sorting grabs for excavators. It is normal, in some areas, for regulations to request added cab filtration and protection from composting airborne debris.

## **WASTE RELATED ENERGY PRODUCTION**

There are a variety of ways to produce energy from waste. C&D landfills, green waste, biodigesters, and composting facilities, will process wood, organics and other products for: gasification, bio fuels, possible incineration, and energy from newer technologies.

## **LANDFILLS — RENEWABLE POWER WITH LANDFILL GAS**

Landfill gas, composed mostly of methane and carbon dioxide, is produced naturally as organic waste decomposes in landfills. Driven by mandate of carbon reduction goals, modern sanitary landfills capture this gas for use as a renewable fuel in specially configured Cat landfill gas generator sets. These systems deliver reliable and environmentally sound electricity to the local community from 400 kW to 2 mW power nodes.

Please contact your local dealership, Waste representative, or *Cat.com* for more information.

Cat Waste Handling Track-Type Tractor modifications are purpose built and installed at the original manufacturing facility prior to shipment.

#### Features:

- **Hinged heavy duty radiator doors** are guarded to prevent excessive trash build-up. Quick release handles allow easy access for cleaning.
- **Final drive, pivot shaft, and idler seal guarding** helps prevent wire, cable and similar material from winding around components and damaging seals.
- **Striker bars for front, rear and ripper (all optional)** keep trash from damaging fenders, fuel and hydraulic tanks or other sheet metal.
- **Lighting protection.** Front lights are mounted on top of bulldozer lift cylinders. Rear lights are ROPS mounted.
- **Waste Handling Arrangement radiator** with 6 fins/inch.
- **Elevated sprocket** removes final drives from wear environment and eliminates impact loading for extended power train life. D7E includes D10-size bearings to ensure long life.
- **Sheet metal guarding** near track and on dozer tilt hoses.
- **Fuel tank guards** keep trash from damaging fuel and hydraulic tanks or other sheet metal.
- **Final drive guards** — guard installed over the final drives to help prevent wire wrap. Guards include inspection plates, not available for D6N.
- **Reversible hydraulic demand fan** required for D6T, D7E, D8T, D9T, not available for D6N.
- **Heavy duty steps and grab handles** resist damage from landfill debris.
- **Center hole track shoes (optional)** help minimize the effects of track packing during machine operation.
- **Blade trash racks (optional)** prevent blade spill-over and damage to cylinders or radiator guard. Increase productivity in waste handling.
- **Ducted alternator available on D6T, D8T, D9T** insures adequate current is available to maintain battery and operate accessories. Not required on D7E.
- **Elevated prescreener** to remove engine air inlet from debris environment. Larger surface area to resist plugging.
- **Precleaner** removes large particulates from incoming air before they reach the air filter, helps extend filter life. (Optional on D6T through D9T.)
- **ROPS mounted air conditioning** helps prevent condenser core plugging. Provides full utilization of jacket water cooling system by avoiding additional heat load from radiator mounted condenser.
- **Laminated thermal shields** cover the CEM inside the engine compartment, hot-side of the turbocharger, and the exhaust manifold. These shields reduce surface temperatures below the flash point of most common combustibles encountered.
- **Chassis Guards.**
- **Sealed belly guards.**
- **Perforated engine enclosures** standard on D6T, D7E, D8T, and D9T. This configuration is unavailable when Sound Suppression is ordered.
- **Carrier rollers** not recommended on elevated sprocket machines.

<b>MODEL</b>	<b>D6N XL WH</b>		<b>D6N LGP WH</b>	
Emission Standards	<b>Tier 4 Final***</b>		<b>Tier 4 Final***</b>	
Flywheel Power	111.8 kW	<b>150 hp</b>	111.8 kW	<b>150 hp</b>
Operating Weight (Power Shift Differential Steer)* SU Blade	—		—	
Engine Model	<b>C6.6 ACERT™</b>		<b>C6.6 ACERT</b>	
Rated Engine RPM	<b>2200</b>		<b>2200</b>	
No. of Cylinders	<b>6</b>		<b>6</b>	
Bore	105 mm	<b>4.13"</b>	105 mm	<b>4.13"</b>
Stroke	127 mm	<b>5.0"</b>	127 mm	<b>5.0"</b>
Displacement	6.6 L	<b>403 in<sup>3</sup></b>	6.6 L	<b>403 in<sup>3</sup></b>
Track Rollers (Each Side)	<b>7</b>		<b>8</b>	
Width of Standard Track Shoe	610 mm	<b>2'0"</b>	840 mm	<b>2'9"</b>
Length of Track on Ground	2581 mm	<b>8'6"</b>	3117 mm	<b>10'3"</b>
Ground Contact Area (with Std. Shoe)	3.15 m <sup>2</sup>	<b>4882 in<sup>2</sup></b>	5.24 m <sup>2</sup>	<b>8122 in<sup>2</sup></b>
Track Gauge	1.89 m	<b>6'2"</b>	2.16 m	<b>7'1"</b>
<b>GENERAL DIMENSIONS:</b>				
Height (Stripped Top)**	—		—	
Height (To Top of ROPS Canopy)	3.04 m	<b>10'0"</b>	3.14 m	<b>10'4"</b>
Height (To Top of ROPS Cab)	3.10 m	<b>10'2"</b>	3.20 m	<b>10'6"</b>
Overall Length (without Blade)	3.74 m	<b>12'3"</b>	4.17 m	<b>13'8"</b>
with S Blade	—		—	
with SU Blade	5.16 m	<b>16'11"</b>	—	
with VPAT Blade	4.90 m	<b>16'1"</b>	5.37 m	<b>17'7"</b>
Width (over Trunnion)	2.63 m	<b>8'8"</b>	—	
Width (without Trunnion — Std. Track)	2.50 m	<b>8'2"</b>	—	
Ground Clearance	394 mm	<b>1'4"</b>	507 mm	<b>1'8"</b>
<b>Blade Types and Widths:</b>				
Straight	—		—	
Semi-U	3.19 m	<b>10'6"</b>	—	
VPAT (Variable pitch, angle, and tilt) straight	3.27 m	<b>10'9"</b>	4.08 m	<b>13'5"</b>
Fuel Tank Refill Capacity	299 L	<b>79 U.S. gal</b>	299 L	<b>79 U.S. gal</b>

\*Operating Weight includes ROPS canopy, operator, lubricants, coolant, full fuel tank, hydraulic controls and fluid, straight dozer with tilt, horn, back-up alarm, retrieval hitch and front pull hook.

\*\*Height (stripped top) — without ROPS canopy, exhaust, precleaner, seat back or other easily removed encumbrances.

\*\*\*Meets U.S. EPA Tier 4 Final, EU Stage IV and Japan 2014 (Tier 4 Final) emission standards.

MODEL	D6T WH		D6T XL WH	
	Tier 4 Final***		Tier 4 Final***	
Emission Standards				
Flywheel Power	149 kW	200 hp	149 kW	200 hp
Operating Weight (Power Shift Differential Steer)* SU Blade	20 580 kg	45,370 lb	21 600 kg	47,620 lb
Engine Model	C9 ACERT		C9 ACERT	
Rated Engine RPM: Power Shift	1850		1850	
No. of Cylinders	6		6	
Bore	112 mm	4.4"	112 mm	4.4"
Stroke	149 mm	5.9"	149 mm	5.9"
Displacement	8.8 L	537 in <sup>3</sup>	8.8 L	537 in <sup>3</sup>
Track Rollers (Each Side)	6		7	
Width of Standard Track Shoe	560 mm	22"	560 mm	22"
Length of Track on Ground	2.61 m	8'7"	2.81 m	9'3"
Ground Contact Area (with Std. Shoe)	2.92 m <sup>2</sup>	4531 in <sup>2</sup>	3.15 m <sup>2</sup>	4878 in <sup>2</sup>
Track Gauge	1.88 m	74"	1.88 m	74"
GENERAL DIMENSIONS:				
Height (Stripped Top)**	2.40 m	7'11"	2.40 m	7'11"
Height (To Top of ROPS Canopy)	3.11 m	10'2"	3.11 m	10'2"
Height (To Top of ROPS Cab)	3.11 m	10'2"	3.11 m	10'2"
Overall Length (without Blade)	3.85 m	12'7"	3.85 m	12'7"
with SU Blade	5.08 m	16'8"	5.33 m	17'6"
with Angle Blade	5.00 m	16'5"	5.21 m	17'1"
Width (over Trunnion)	2.64 m	8'8"	2.64 m	8'8"
Width (without Trunnion — Std. Track)	2.44 m	8'0"	2.44 m	8'0"
Ground Clearance	384 mm	1'3"	384 mm	1'3"
Blade Types and Widths:				
Angle Straight	4.16 m	13'8"	4.16 m	13'8"
Full 25° Angle	3.77 m	12'5"	3.77 m	12'5"
Semi-U	3.26 m	10'8"	3.26 m	10'8"
Fuel Tank Refill Capacity	425 L	112 U.S. gal	425 L	112 U.S. gal

\*Operating Weight includes ROPS canopy, operator, lubricants, coolant, full fuel tank, hydraulic controls and fluid, straight dozer with tilt, horn, back-up alarm, retrieval hitch, front pull hook and standard WHA Attachments.

\*\*Height (stripped top) — without ROPS canopy, exhaust, precleaner, seat back or other easily removed encumbrances.

\*\*\*Meets Tier 4 Final, Stage IV and Japan 2014 (Tier 4 Final) emission standards.

<b>MODEL</b>	<b>D6T XL WH</b>		<b>D6T XW WH</b>		<b>D6T LGP WH</b>	
Emission Standards	<b>Tier 4 Final****</b>		<b>Tier 4 Final****</b>		<b>Tier 4 Final****</b>	
Flywheel Power	151 kW	<b>202 hp</b>	151 kW	<b>202 hp</b>	151 kW	<b>202 hp</b>
Operating Weight:*						
Power Shift Differential Steer	23 236 kg	<b>51,226 lb</b>	24 221 kg	<b>53,286 lb</b>	24 900 kg	<b>50,895 lb</b>
VPAT	25 420 kg	<b>56,050 lb</b>	26 535 kg	<b>58,500 lb</b>	27 015 kg	<b>59,557 lb</b>
Engine Model	<b>C9.3 ACERT</b>		<b>C9.3 ACERT</b>		<b>C9.3 ACERT</b>	
Rated Engine RPM	<b>2000</b>		<b>2000</b>		<b>2000</b>	
No. of Cylinders	<b>6</b>		<b>6</b>		<b>6</b>	
Bore	115 mm	<b>4.5"</b>	115 mm	<b>4.5"</b>	115 mm	<b>4.5"</b>
Stroke	149 mm	<b>5.9"</b>	149 mm	<b>5.9"</b>	149 mm	<b>5.9"</b>
Displacement	9.3 L	<b>567 in<sup>3</sup></b>	9.3 L	<b>567 in<sup>3</sup></b>	9.3 L	<b>567 in<sup>3</sup></b>
Track Rollers (Each Side)	<b>7</b>		<b>7</b>		<b>8</b>	
Width of Standard Track Shoe	560 mm	<b>22"</b>	760 mm	<b>30"</b>	915 mm	<b>36"</b>
VPAT	560 mm	<b>22"</b>	710 mm	<b>28"</b>	785 mm	<b>31"</b>
Length of Track on Ground	2.86 m	<b>9'5"</b>	2.86 m	<b>9'5"</b>	3.27 m	<b>10'9"</b>
VPAT	2.86 m	<b>9'5"</b>	3.27 m	<b>10'9"</b>	3.27 m	<b>10'9"</b>
Ground Contact Area (with Std. Shoe)	3.20 m <sup>2</sup>	<b>4929 in<sup>2</sup></b>	4.35 m <sup>2</sup>	<b>6738 in<sup>2</sup></b>	5.98 m <sup>2</sup>	<b>9275 in<sup>2</sup></b>
VPAT	3.20 m <sup>2</sup>	<b>4929 in<sup>2</sup></b>	4.64 m <sup>2</sup>	<b>7197 in<sup>2</sup></b>	5.13 m <sup>2</sup>	<b>7956 in<sup>2</sup></b>
Track Gauge	1.88 m	<b>74"</b>	2.03 m	<b>80"</b>	2.29 m	<b>90"</b>
VPAT	2.13 m	<b>84"</b>	2.29 m	<b>90"</b>	2.29 m	<b>90"</b>
<b>GENERAL DIMENSIONS:</b>						
Height** (Stripped Top***)	2.46 m	<b>8'1"</b>	2.46 m	<b>8'1"</b>	2.51 m	<b>8'3"</b>
VPAT	2.46 m	<b>8'1"</b>	2.51 m	<b>8'3"</b>	2.51 m	<b>8'3"</b>
Height** (To Top of ROPS Canopy)	3.11 m	<b>10'2"</b>	3.11 m	<b>10'2"</b>	3.16 m	<b>10'4"</b>
VPAT	3.11 m	<b>10'2"</b>	3.16 m	<b>10'4"</b>	3.16 m	<b>10'4"</b>
Height** (To Top of ROPS Cab)	3.15 m	<b>10'4"</b>	3.15 m	<b>10'4"</b>	3.20 m	<b>10'6"</b>
VPAT	3.15 m	<b>10'4"</b>	3.20 m	<b>10'6"</b>	3.20 m	<b>10'6"</b>
Overall Length (without Blade)	3.89 m	<b>12'9"</b>	3.89 m	<b>12'9"</b>	4.25 m	<b>13'11"</b>
VPAT	3.89 m	<b>12'9"</b>	4.25 m	<b>13'11"</b>	4.25 m	<b>13'11"</b>
with S Blade	—	—	—	—	5.50 m	<b>18'1"</b>
with SU Blade	5.33 m	<b>17'6"</b>	5.33 m	<b>17'6"</b>	—	—
with VPAT Blade	5.39 m	<b>17'8"</b>	5.53 m	<b>18'2"</b>	5.53 m	<b>18'2"</b>
with Angle Blade	5.21 m	<b>17'1"</b>	5.29 m	<b>17'4"</b>	5.81 m	<b>19'1"</b>
Width (over Trunnion)	2.64 m	<b>8'8"</b>	2.95 m	<b>9'8"</b>	3.43 m	<b>11'3"</b>
Width (without Trunnion — Std. Track)	2.44 m	<b>8'0"</b>	2.79 m	<b>9'2"</b>	3.21 m	<b>10'6"</b>
VPAT	2.69 m	<b>8'10"</b>	3.00 m	<b>9'10"</b>	3.08 m	<b>10'1"</b>
Ground Clearance**	384 mm	<b>1'3"</b>	384 mm	<b>1'3"</b>	434 mm	<b>1'5"</b>
VPAT	384 mm	<b>1'3"</b>	434 mm	<b>1'5"</b>	434 mm	<b>1'5"</b>
<b>Blade Types and Widths:</b>						
Straight	—	—	—	—	4.06 m	<b>13'4"</b>
Angle Straight	4.16 m	<b>13'8"</b>	4.52 m	<b>14'10"</b>	5.07 m	<b>16'8"</b>
Full 25° Angle	3.77 m	<b>12'5"</b>	4.11 m	<b>13'6"</b>	4.63 m	<b>15'2"</b>
Semi-U	3.26 m	<b>12'8"</b>	3.56 m	<b>11'8"</b>	—	—
VPAT Straight	3.88 m	<b>12'9"</b>	4.16 m	<b>13'8"</b>	4.16 m	<b>13'8"</b>
VPAT Full 24° Angle	3.49 m	<b>11'5"</b>	3.72 m	<b>12'2"</b>	3.72 m	<b>12'2"</b>
Fuel Tank Refill Capacity	425 L	<b>112 U.S. gal</b>	425 L	<b>112 U.S. gal</b>	425 L	<b>112 U.S. gal</b>

\*Operating Weight includes cab, operator, lubricants, coolant, full fuel tank, standard track, hydraulic controls and fluid, SU blade, drawbar, and standard WHA attachments.

\*\*Dimensions measured from ground line. Add grouser height for total dimension on hard surfaces.

\*\*\*Height (stripped top) — without ROPS canopy, exhaust, seat back or other easily removed encumbrances.

\*\*\*\*Meets Tier 4 Final, Stage IV and Japan 2014 (Tier 4 Final) emission standards.

MODEL	D7E WH		D7E LGP WH		D8R WH		D8T WH	
Emission Standards	Tier 4 Final <sup>1</sup>		Tier 4 Final <sup>1</sup>		Tier 2 Equivalent <sup>2</sup>		Tier 3 Equivalent <sup>3</sup>	
Flywheel Power	—		—		228 kW 305 hp		231 kW 310 hp	
Advertised Flywheel Power	175 kW	235 hp	175 kW	235 hp	—		—	
Operating Weight: <sup>*</sup>								
Electric Drive Differential Steer	28 908 kg	63,730 lb	31 116 kg	68,600 lb	—		—	
Power Shift Differential Steer	—		—		37 630 kg	82,880 lb	38 660 kg	85,150 lb
Engine Model	C9.3 ACERT		C9.3 ACERT		3406ETA		C15 ACERT	
Rated Engine RPM	—		—		2100		1850	
Advertised Engine RPM	1700		1700		—		—	
No. of Cylinders	6		6		6		6	
Bore	115 mm	4.5"	115 mm	4.5"	137 mm	5.4"	137 mm	5.4"
Stroke	149 mm	5.9"	149 mm	5.9"	165 mm	6.5"	172 mm	6.75"
Displacement	9.3 L	567 in <sup>3</sup>	9.3 L	567 in <sup>3</sup>	14.6 L	893 in <sup>3</sup>	15.2 L	928 in <sup>3</sup>
Track Rollers (Each Side)	7		8		8		8	
Width of Standard Track Shoe	610 mm	24"	915 mm	36"	560 mm	1'10"	560 mm	1'10"
Length of Track on Ground	3.02 m	9'11"	3.45 m	11'4"	3.21 m	10'6"	3.21 m	10'6"
Ground Contact Area (with Std. Shoe)	3.68 m <sup>2</sup>	5698 in <sup>2</sup>	6.31 m <sup>2</sup>	9792 in <sup>2</sup>	3.57 m <sup>2</sup>	5544 in <sup>2</sup>	3.58 m <sup>2</sup>	5544 in <sup>2</sup>
Track Gauge	1.98 m	6'6"	2.29 m	7'6"	2.08 m	6'10"	2.08 m	6'10"
GENERAL DIMENSIONS:								
Height (Stripped Top)**	—		—		2.67 m	8'9"	2.67 m	8'9"
Height (To Top of ROPS Canopy)	—		—		3.51 m	11'6"	3.46 m	11'4"
Height*** (To Top of ROPS Cab)	3.32 m	10'11"	3.32 m	10'11"	3.45 m	11'3"	3.46 m	11'4"
Overall Length (without Blade)	4.88 m	16'0"	4.88 m	16'0"	4.93 m	16'2"	4.64 m	15'3"
with S Blade	5.86 m	19'3"	5.56 m	18'3"	—		6.09 m	20'0"
with SU Bladet	6.07 m	19'11"	—		6.91 m	22'8"	6.91 m	22'8"
Width (over Trunnion)	2.88 m	9'5"	3.42 m	11'3"	3.05 m	10'0"	3.05 m	10'0"
Width (without Trunnion — Std. Shoe)	2.59 m	8'6"	3.2 m	10'6"	2.70 m	8'8"	2.64 m	8'8"
Ground Clearance	472 mm	18.6"	472 mm	18.6"	606 mm	1'11"	618 mm	2'4"
Blade Types and Widths:								
Straight	3.9 m	12'10"	4.54 m	14'11"	—		—	
Angle Straight	—		—		4.99 m	16'4"	4.99 m	16'4"
Full 25° Angle	—		—		4.52 m	14'10"	4.52 m	14'10"
Universal	3.99 m	13'1"	—		4.26 m	14'0"	4.26 m	14'0"
Semi-U	3.71 m	12'2"	—		3.94 m	12'11"	3.94 m	12'11"
Fuel Tank Refill Capacity	409 L	108 U.S. gal	409 L	108 U.S. gal	625 L	165 U.S. gal	643 L	170 U.S. gal

\*Operating Weight for D7E WH and D7E LGP WH includes cab, operator, lubricants, coolant, full fuel tank, standard track, hydraulic controls and fluid, SU blade and drawbar.

Operating Weight for D8R WH includes ROPS cab, operator, lubricants, coolant, full fuel tank, standard track, hydraulic controls and fluid, SU blade with trash rack, retrieval hitch, front pull hook, and track guides.

Operating Weight for D8T WH includes ROPS canopy, operator, lubricants, coolant, full fuel tank, hydraulic controls and fluids, SU blade with tilt, back-up alarm, seat belts, lights, rigid drawbar and front towing device.

— D8T WH equipped with track guides, ROPS/FOPS cab, and SU blade.

\*\*Height (stripped top) — without ROPS canopy, exhaust, seat back or other easily removed encumbrances.

\*\*\*Dimensions for D7E LGP WH measured from ground line. Add grouser height for total dimension on hard surfaces.

†D8R WH and D8T WH include drawbar.

<sup>1</sup>Meets Tier 4 Final, Stage IV and Japan 2014 (Tier 4 Final) emission standards.

<sup>2</sup>Meets Tier 2, Stage II, Japan 2001 (Tier 2) equivalent emission standards.

<sup>3</sup>Meets Tier 3, Stage IIIA, Japan 2006 (Tier 3) equivalent emission standards.



<b>MODEL</b>	<b>D8T WH</b>		<b>D9T WH</b>		<b>D9T WH</b>	
Emission Standards	<b>Tier 4 Final<sup>1</sup></b>		<b>Tier 2 Equivalent or Tier 3 Equivalent<sup>2</sup></b>		<b>Tier 4 Final<sup>1</sup></b>	
Flywheel Power	233 kW	<b>312 hp</b>	306 kW	<b>410 hp</b>	325 kW	<b>436 hp</b>
Operating Weight: <sup>*</sup>						
Power Shift Differential Steer	39 331 kg	<b>86,710 lb</b>	49 761 kg	<b>109,705 lb</b>	50 109 kg	<b>110,471 lb</b>
Engine Model	<b>C15 ACERT</b>		<b>C18 ACERT</b>		<b>C18 ACERT</b>	
Rated Engine RPM	<b>1900</b>		<b>1833</b>		<b>1800</b>	
No. of Cylinders	<b>6</b>		<b>6</b>		<b>6</b>	
Bore	137 mm	<b>5.4"</b>	145 mm	<b>5.7"</b>	145 mm	<b>5.7"</b>
Stroke	172 mm	<b>6.75"</b>	183 mm	<b>7.2"</b>	183 mm	<b>7.2"</b>
Displacement	15.2 L	<b>928 in<sup>3</sup></b>	18.1 L	<b>1106 in<sup>3</sup></b>	18.1 L	<b>1106 in<sup>3</sup></b>
Track Rollers (Each Side)	<b>8</b>		<b>8</b>		<b>8</b>	
Width of Standard Track Shoe	610 mm	<b>2'0"</b>	610 mm	<b>2'0"</b>	610 mm	<b>2'0"</b>
Length of Track on Ground	3.21 m	<b>10'6"</b>	3.47 m	<b>11'5"</b>	3.47 m	<b>11'5"</b>
Ground Contact Area (with Std. Shoe)	3.91 m <sup>2</sup>	<b>6062 in<sup>2</sup></b>	4.24 m <sup>2</sup>	<b>6569 in<sup>2</sup></b>	4.24 m <sup>2</sup>	<b>6569 in<sup>2</sup></b>
Track Gauge	2.08 m	<b>6'10"</b>	2.25 m	<b>7'5"</b>	2.25 m	<b>7'5"</b>
<b>GENERAL DIMENSIONS:</b>						
Height (Stripped Top)**	2.67 m	<b>8'9"</b>	3.69 m	<b>12'1"</b>	3.69 m	<b>12'1"</b>
Height (To Top of ROPS Canopy)	3.46 m	<b>11'4"</b>	4.00 m	<b>13'1"</b>	4.00 m	<b>13'1"</b>
Height (To Top of ROPS Cab)	3.46 m	<b>11'4"</b>	3.82 m	<b>12'6"</b>	3.82 m	<b>12'6"</b>
Overall Length (without Blade and without Drawbar)	4.64 m	<b>15'3"</b>	4.91 m	<b>16'1"</b>	4.91 m	<b>16'1"</b>
with SU Landfill Blade***	6.09 m	<b>20'0"</b>	6.86 m	<b>22'5"</b>	6.86 m	<b>22'5"</b>
Width (over Trunnion)	3.06 m	<b>10'0"</b>	3.30 m	<b>10'8"</b>	3.30 m	<b>10'8"</b>
Width (without Trunnion — Std. Shoe)	2.64 m	<b>8'8"</b>	2.88 m	<b>9'5"</b>	2.88 m	<b>9'5"</b>
Ground Clearance	618 mm	<b>2'4"</b>	496 mm	<b>1'7"■</b>	496 mm	<b>1'7"■</b>
<b>Blade Types and Widths:</b>						
Angle Straight	4.99 m	<b>16'4"</b>	—	—	—	—
Full 25° Angle	4.52 m	<b>14'10"</b>	—	—	—	—
Universal	4.26 m	<b>14'0"</b>	4.65 m	<b>15'3"</b>	4.65 m	<b>15'3"</b>
Semi-U	3.94 m	<b>12'11"</b>	4.31 m	<b>14'2"</b>	4.31 m	<b>14'2"</b>
Fuel Tank Refill Capacity	643 L	<b>170 U.S. gal</b>	889 L	<b>235 U.S. gal</b>	821 L	<b>217 U.S. gal</b>
DEF Tank Capacity	—	—	—	—	36 L	<b>9.5 U.S. gal</b>

\*Operating Weight includes ROPS canopy, operator, lubricants, coolant, full fuel tank, hydraulic controls and fluids, SU blade with tilt, back-up alarm, seat belts, lights, rigid drawbar and front towing device.

— D8T WH equipped with track guides, ROPS/FOPS cab, and SU blade.  
— D9T WH equipped with track guides, ROPS/FOPS cab, single shank ripper and SU blade.

\*\*Height (stripped top) — without ROPS canopy, exhaust, seat back or other easily removed encumbrances. Dimensions measured from ground line. Add grouser height for total dimension on hard surfaces.

\*\*\*Includes drawbar.

■ ISO 6746 — Dimensions measured from ground line to lowest point under machine. Add grouser height for total dimension on hard surfaces.

<sup>1</sup> Meets Tier 4 Final, Stage IV and Japan 2014 (Tier 4 Final) emission standards.

<sup>2</sup> Meets Tier 2, Stage II, Japan 2001 (Tier 2) equivalent or Tier 3, Stage IIIA, Japan 2006 (Tier 3) equivalent emission standards.

MODEL	D6N XL		D6N LGP		D6T WH	
	6VPAT XL		6VPAT LGP		6SU	
Type	Variable Pitch Power Angle and Tilt		Variable Pitch Power Angle and Tilt		Semi Universal	
Blade Capacities with Trash Rack*	6.4 m <sup>3</sup>	8.37 yd <sup>3</sup>	4.6 m <sup>3</sup>	6.02 yd <sup>3</sup>	10.9 m <sup>3</sup>	14.3 yd <sup>3</sup>
Weight, Shipping** (Dozer)	1206 kg	2659 lb	1338 kg	2950 lb	3026 kg	6657 lb
Tractor and Dozer Dimensions:						
A Length (Blade Straight)	4903 mm	16'1"	5369 mm	17'7"	5.31 m	17'5"
Blade Dimensions:						
B Width (including std. end bits)	3272 mm	10'9"	4082 mm	13'5"	3.26 m	10'8"
C Height	1702 mm	5'7"	1447 mm	4'9"	2019 mm	6'7"
D Max. Digging Depth	374 mm	1'2.7"	387 mm	1'3.2"	453 mm	1'6"
E Ground Clearance @ Full Lift	994 mm	3'3.1"	1074 mm	3'6.3"	1204 mm	3'11"
F Manual Tilt	—		—		—	
G Max. Pitch	+2.8° to -4.7°		+2.8° to -4.7°		+5.6° to -5.2°	
H Max. Hydraulic Tilt	584 mm	1'11"	658.6 mm	2'1.9"	811 mm	2'8"
J Hydraulic Tilt (Manual Brace Centered)	—		—		455 mm	1'6"

\*Blade capacities as determined by SAE J1265.

Notice that the capacity of the U-blade is the volume carried by a straight blade of the same dimensions plus the volume included in the "cup" of the U-blade. It is intended for **relative comparisons of dozer sizes**, and not for predicting capacities or productivities in actual field conditions.

\*\*Shipping Weight — Total Bulldozer Arrangement includes: Blade, push arms or C-frame, braces, cylinders, lines, trunnions and lift cylinder mountings.

MODEL	D6T WH and D6T Tier 4 Interim/Stage IIIB WH					
	6SU XL		6S LGP		6SU XW	
Type	Semi Universal		Straight		Semi Universal	
Blade Capacities*	10.9 m <sup>3</sup>	14.3 yd <sup>3</sup>	9.4 m <sup>3</sup>	12.3 yd <sup>3</sup>	11.3 m <sup>3</sup>	14.7 yd <sup>3</sup>
Weight, Shipping** (Dozer)	3026 kg	6657 lb	2840 kg	6262 lb	3181 kg	7013 lb
Tractor and Dozer Dimensions:						
A Length (Blade Straight)	5.31 m	17'5"	5.5	18'1"	5.31 m	17'5"
Blade Dimensions:						
B Width (including std. end bits)	3.26 m	10'8"	4.08 m	13'4"	3.56 m	11'8"
C Height	2019 mm	6'7"	1764 mm	5'9"	2019 mm	6'7"
D Max. Digging Depth	453 mm	1'6"	658 mm	2'2"	453 mm	1'6"
E Ground Clearance @ Full Lift	1204 mm	3'11"	1088 mm	3'7"	1204 mm	3'11"
F Manual Tilt	—		—		—	
G Max. Pitch	+5.6° to -5.2°		+4.4° to -4.4°		+5.6° to -5.2°	
H Max. Hydraulic Tilt	811 mm	2'8"	747 mm	2'5"	811 mm	2'8"
J Hydraulic Tilt (Manual Brace Centered)	455 mm	1'6"	421 mm	1'5"	455 mm	1'6"

\*Blade capacities as determined by SAE J1265. Model 6SU XL blade capacities with trash rack.

Notice that the capacity of the U-blade is the volume carried by a straight blade of the same dimensions plus the volume included in the "cup" of the U-blade. It is intended for **relative comparisons of dozer sizes**, and not for predicting capacities or productivities in actual field conditions.

\*\*Shipping Weight — Total Bulldozer Arrangement includes: Blade, push arms or C-frame, braces, cylinders, lines, trunnions and lift cylinder mountings.

MODEL	D7E LGP WH				D8T WH			
	7S		8SU		8U		8SU LGP	
Type								
Blade Capacities*	19.1 m <sup>3</sup>	<b>25 yd<sup>3</sup></b>	20 m <sup>3</sup>	<b>26.1 yd<sup>3</sup></b>	24.8 m <sup>3</sup>	<b>32.4 yd<sup>3</sup></b>	21.1 m <sup>3</sup>	<b>27.6 yd<sup>3</sup></b>
Dozer Weight**	4026 kg	<b>8875 lb</b>	5466 kg	<b>12,025 lb</b>	6313 kg	<b>13,888 lb</b>	5624 kg	<b>12,400 lb</b>
Tractor and Dozer Dimensions:								
Length Blade Straight	6.28 m	<b>20'7"</b>	6.39 m	<b>21'0"</b>	6.79 m	<b>22'3"</b>	6.39 m	<b>21'0"</b>
Blade Dimensions:								
Width including std. end bits	4.58 m	<b>15'0"</b>	3.94 m	<b>12'11"</b>	4.26 m	<b>14'0"</b>	4.52 m	<b>14'10"</b>
Height	2418 mm	<b>7'11"</b>	2464 mm	<b>8'1"</b>	2515 mm	<b>8'3"</b>	2465 mm	<b>8'1"</b>
Maximum Dig Depth	640 mm	<b>25 in</b>	582 mm	<b>1'10.9"</b>	582 mm	<b>1'10.9"</b>	582 mm	<b>1'10.9"</b>
Ground Clearance at full raise	1285 mm	<b>4'3"</b>	1231 mm	<b>4'0.5"</b>	1231 mm	<b>4'0.5"</b>	1231 mm	<b>4'1"</b>
Maximum Hydraulic Tilt	470 mm	<b>1'7"</b>	951 mm	<b>3'1.4"</b>	1028 mm	<b>3'4.5"</b>	—	

\*Blade capacities, weights and heights include 1075 mm (3'6") trash rack on D7E LGPWH blades and 762 mm (2'6") trash rack on D8TWH blades.

\*\*Total bulldozer arrangement includes blade with trash rack, pusharms, braces, cylinders, lines, trunnions and lift cylinder mountings.

MODEL	D9T WH			
	9SU		9U	
Type				
Blade Capacities*	28.8 m <sup>3</sup>	<b>37.6 yd<sup>3</sup></b>	33.5 m <sup>3</sup>	<b>43.8 yd<sup>3</sup></b>
Dozer Weight**	8051 kg	<b>17,749 lb</b>	8704 kg	<b>19,189 lb</b>
Tractor and Dozer Dimensions:				
Length Blade Straight	6.84 m	<b>22'5"</b>	7.18 m	<b>23'7"</b>
Blade Dimensions:				
Width including std. end bits	4.31 m	<b>14'2"</b>	4.65 m	<b>15'3"</b>
Height	2845 mm	<b>9'4"</b>	2845 mm	<b>9'4"</b>
Maximum Dig Depth	606 mm	<b>1'11.9"</b>	606 mm	<b>1'11.9"</b>
Ground Clearance at full raise	1422 mm	<b>4'8"</b>	1422 mm	<b>4'8"</b>
Maximum Hydraulic Tilt	940 mm	<b>3'1"</b>	1014 mm	<b>3'3.9"</b>

\*Blade capacities, weights and heights include 914 mm (3'0") trash rack on D9TWH blades.

\*\*Total bulldozer arrangement includes blade with trash rack, pusharms, braces, cylinders, lines, trunnions and lift cylinder mountings.

**Features:**

- **Unmatched versatility** — excavates, loads, carries, covers, dozes, spreads, compacts, shreds, sorts, grapples — a true all purpose machine. Performs well as a one-machine fleet, a support machine or an all-around backup unit.
- **Demolition applications** — The Waste Handling Arrangement (963D and 973D Waste Extreme Service) can also be used in demolition or demolition transfer stations when properly equipped with the extra guarding required for this severe environment.
- **Special guard** protects the final drive seals, pivot shafts and idlers from debris that can wrap around and damage these components.
- **Cat Turbine Precleaner** with prescreener to prevent airborne debris from clogging engine air intake.
- **Additional heavy duty guarding** helps protect sheet metal and machine components from damage in waste handling applications.
- **Improved serviceability** — swing open doors, guards and air coolers give quick access for cleaning debris and servicing.
- **Hinged, heavy duty radiator guard** with quick release “T” handles allows for easy access to clean the radiator.
- **Debris Barrier Package** protects machine from material entering engine and other compartments.
- **Lamp guard group** protects front and rear lamps with bolt on grids.
- **Optional rear striker bars** keep trash from climbing the track and damaging fenders.
- **Optional final drive abrasion guards** are available in two-piece or four-piece sections to protect the final drive case from premature wear from abrasion or gouging.
- **Optional trapezoidal-shaped center hole track shoes** provide maximum traction. The center holes allow sprocket to punch out dirt and debris, best choice for landfill applications.
- **Hydraulic reversing fan (953D and 963D) or variable pitch cooling fan** (optional on 973D) manually or automatically changes direction to purge accumulated debris from the radiator.
- **Cab and Operator Comfort** — Standard air suspension seat, air conditioning, adjustable steering pedals, storage area, and excellent visibility enable the operator to be more comfortable in this application for better profitability.

<b>MODEL</b>	<b>953D WH</b>		<b>963D WH</b>		<b>973D WH</b>	
Emission Standards	<b>Tier 3 Equivalent**</b>		<b>Tier 3 Equivalent**</b>		<b>Tier 3 Equivalent**</b>	
Flywheel Power	110 kW	<b>148 hp</b>	141 kW	<b>189 hp</b>	196 kW	<b>263 hp</b>
Operating Weight*	15 595 kg	<b>34,381 lb</b>	21 000 kg	<b>46,305 lb</b>	29 555 kg	<b>65,158 lb</b>
Engine Model	<b>C6.6 ACERT</b>		<b>C6.6 ACERT</b>		<b>C9 ACERT</b>	
Rated Engine RPM	<b>2000</b>		<b>2000</b>		<b>1900</b>	
Bore	105 mm	<b>4"</b>	105 mm	<b>4.13"</b>	112 mm	<b>4.41"</b>
Stroke	127 mm	<b>5"</b>	127 mm	<b>5"</b>	149 mm	<b>5.87"</b>
No. Cylinders	<b>6</b>		<b>6</b>		<b>6</b>	
Displacement	6.6 L	<b>402.7 in<sup>3</sup></b>	6.6 L	<b>402.7 in<sup>3</sup></b>	8.8 L	<b>537 in<sup>3</sup></b>
Speeds, Forward/Reverse:						
1st	0-10 km/h	<b>0-6.2 mph</b>	0-10 km/h	<b>0-6.2 mph</b>	0-11 km/h	<b>0-6.8 mph</b>
2nd	<b>Infinitely</b>		<b>Infinitely</b>		<b>Infinitely</b>	
3rd	<b>Variable</b>		<b>Variable</b>		<b>Variable</b>	
Hydraulic Cycle Time, Bucket Empty, in Seconds:						
Raise	<b>6.1</b>		<b>5.9</b>		<b>6.5</b>	
Dump	<b>3.1</b>		<b>3.7</b>		<b>1.4</b>	
Lower (Empty, Float Down)	<b>3.2</b>		<b>2.2</b>		<b>2.7</b>	
Total	<b>—</b>		<b>—</b>		<b>10.6</b>	
Track Rollers (Each Side)	<b>6</b>		<b>6</b>		<b>7</b>	
Width of Standard Track Shoes	480 mm	<b>19"</b>	550 mm	<b>21.6"</b>	550 mm	<b>21.6"</b>
Length of Track on Ground	2323 mm	<b>91.4"</b>	2543 mm	<b>100.1"</b>	2930 mm	<b>115"</b>
Ground Contact Area (with Standard Shoes)	2.3 m <sup>2</sup>	<b>3565 in<sup>2</sup></b>	2.8 m <sup>2</sup>	<b>4340 in<sup>2</sup></b>	3.22 m <sup>2</sup>	<b>4991 in<sup>2</sup></b>
Ground Pressure	65.5 kPa	<b>9.5 psi</b>	71.5 kPa	<b>10.3 psi</b>	90.0 kPa	<b>13.0 psi</b>
Ground Clearance	436 mm	<b>17.2"</b>	483 mm	<b>19"</b>	482 mm	<b>18.9"</b>
Track Gauge	1800 mm	<b>71"</b>	1850 mm	<b>72.8"</b>	2160 mm	<b>85"</b>
Width without Bucket	2280 mm	<b>89.7"</b>	2400 mm	<b>94.5"</b>	2710 mm	<b>106.7"</b>
Fuel Tank Refill Capacity	285 L	<b>75.3 U.S. gal</b>	336.5 L	<b>88.8 U.S. gal</b>	621 L	<b>164 U.S. gal</b>
Hydraulic System Refill Capacity	124 L	<b>32.8 U.S. gal</b>	166 L	<b>43.8 U.S. gal</b>	189 L	<b>50 U.S. gal</b>

\*Includes GP landfill bucket with bolt-on adapters, long tips and segments.

See *Wheel Loader* section of this book for summary of S.A.E. Guidelines for Loader Specifications, to which Caterpillar adheres.

\*\*Meets Tier 3, Stage IIIA, Japan 2006 (Tier 3) equivalent emission standards.

**MULTI-PURPOSE LANDFILL BUCKETS**

Machine Model	953D WH		963D WH		973D WH	
Capacity, rated (Refuse)	2.1 m <sup>3</sup>	<b>2.75 yd<sup>3</sup></b>	2.7 m <sup>3</sup>	<b>3.5 yd<sup>3</sup></b>	4.6 m <sup>3</sup>	<b>6 yd<sup>3</sup></b>
Capacity, rated (Earth)	1.5 m <sup>3</sup>	<b>2 yd<sup>3</sup></b>	1.8 m <sup>3</sup>	<b>2.4 yd<sup>3</sup></b>	2.7 m <sup>3</sup>	<b>3.53 yd<sup>3</sup></b>
Width	2536 mm	<b>99.84"</b>	2573 mm	<b>101.30"</b>	2946 mm	<b>115.9"</b>
Height	1677 mm	<b>66.02"</b>	1750 mm	<b>68.90"</b>	1944 mm	<b>76.58"</b>
Depth	1433 mm	<b>56.41"</b>	1537 mm	<b>60.51"</b>	1607 mm	<b>63.3"</b>
Teeth — Optional		<b>8</b>		<b>8</b>		<b>8</b>
Clearance @ 45° dump	2738 mm	<b>9'0"</b>	2870 mm	<b>9'5"</b>	3060 mm	<b>120.5"</b>
Reach @ 45° dump	961 mm	<b>3'2"</b>	1013 mm	<b>3'4"</b>	1261 mm	<b>49.6"</b>
Digging Depth	147 mm	<b>5.7"</b>	161 mm	<b>6.3"</b>		—
Weight (approx.)	1668 kg	<b>3678 lb</b>	2206 kg	<b>4864 lb</b>	3575 kg	<b>7882 lb</b>

**GENERAL PURPOSE LANDFILL BUCKETS**

Machine Model	953D WH		963D WH		973D WH	
Capacity, rated (Refuse)	2.3 m <sup>3</sup>	<b>3.0 yd<sup>3</sup></b>	3.1 m <sup>3</sup>	<b>4.1 yd<sup>3</sup></b>	4.9 m <sup>3</sup>	<b>6.41 yd<sup>3</sup></b>
Capacity, rated (Earth)	1.75 m <sup>3</sup>	<b>2.29 yd<sup>3</sup></b>	2.3 m <sup>3</sup>	<b>3.0 yd<sup>3</sup></b>	3.2 m <sup>3</sup>	<b>4.2 yd<sup>3</sup></b>
Width	2458 mm	<b>96.77"</b>	2612 mm	<b>102.83"</b>	2910 mm	<b>114.6"</b>
Height	1607 mm	<b>63.2"</b>	1778 mm	<b>70"</b>	1936 mm	<b>76.2"</b>
Depth	1450 mm	<b>57.1"</b>	1480 mm	<b>58.3"</b>	1491 mm	<b>58.7"</b>
Teeth — Optional		<b>8</b>		<b>8</b>		<b>8</b>
Clearance @ 45° dump	2855 mm	<b>9'0"</b>	3155 mm	<b>10'4"</b>	3261 mm	<b>128.4"</b>
Reach @ 45° dump	999 mm	<b>3'3"</b>	1147 mm	<b>3'9"</b>	1191 mm	<b>46.9"</b>
Digging Depth	85 mm	<b>5.7"</b>	161 mm	<b>6.3"</b>		—
Weight (approx.)	1266 kg	<b>2792 lb</b>	1888 kg	<b>4163 lb</b>	2320 kg	<b>5115 lb</b>

NOTE: 973D GP and MP landfill buckets are equipped with bolt-on segments and teeth general duty.

### Features:

- **Caterpillar designed and manufactured power train** ... for optimum match, performance and efficiency. Responsive Cat diesel engine. Single-lever planetary power shift. All-wheel drive.
- **Center-point articulation** ... excellent maneuverability. Front and rear drums track, so material is chopped and compacted twice each pass.
- **Protective guarding** ... helps keep trash from damaging machine components.
- **Cat landfill blades** spread refuse and cover material ... built strong to handle the wide range of refuse encountered in landfills.
- **Operator comfort and convenience** ... sound suppressed cab with pressurized and filtered air circulation system. Adjustable suspension seat. Electronic Monitoring System and gauge package is standard.
- **Striker bars** ... standard on all Cat Landfill Compactors, prevents refuse from being carried over the rear wheels.
- **Caterpillar designed wheels** ... We test and build a Cat system. Engineers who work together with our power train, structures and manufacturing engineers design and manufacture our wheels in the same facility in which the machines are designed and built. This ensures the entire system is complemented by each component. If you alter components, you could compromise a system that was designed and tested for peak performance. If a wheel is produced that does not meet our design specifications and does not balance the load over our final drives, it could reduce the life of the bearing substantially and wear out other components creating unnecessary downtime. This also allows our standard axle guard system to work with the components for which it was designed.
- **Wheel and tip configurations** ... Three new wheel and tip configurations are available to meet your particular application:
  - 1) **Paddle tip** — High performance and less fuel burn with more traction and less weight.
  - 2) **Plus tip** — Traditional design for increased side slope stability and more mass for longer life.
  - 3) **Combination tip** — Both paddle and plus tips to give high performance with side slope stability.

MODEL	816F2		826K		836K	
Emission Standards	Tier 3 Equivalent <sup>1</sup>		Tier 4 Final <sup>2</sup>		Tier 4 Final <sup>2</sup>	
Gross Power	189 kW	253 hp	320 kW	430 hp	419 kW	562 hp
Operating Weight*	23 744 kg	52,364 lb	40 666 kg	89,653 lb	55 927 kg	123,319 lb
Engine Model	C9 ACERT		C15 ACERT		C18 ACERT	
Rated Engine RPM	2100		1800		1800	
No. Cylinders	6		6		6	
Displacement	8.8 L	537 in <sup>3</sup>	15.2 L	928 in <sup>3</sup>	18.1 L	1105 in <sup>3</sup>
Speeds:						
Forward	2		2		2	
Reverse	2		2		2	
Turning Radius with Straight Blade						
Inside Wheels	3.5 m	11'6"	2.8 m	9'2"	3.6 m	11'11"
Outside Blade Corner	6.5 m	21'2"	7.23 m	23'9"	8.8 m	28'11"
Fuel Tank Refill Capacity	464 L	122.6 U.S. gal	782 L	206.6 U.S. gal	793 L	209 U.S. gal
DEF Tank Refill Capacity	—		32.8 L	9.0 U.S. gal	32.8 L	9.0 U.S. gal
WHEELS:	PLUSTIP		PLUSTIP		PLUSTIP	
Each Drum Width	1.02 m	3'4"	1.2 m	3'11"	1.4 m	4'7"
Diameters, over Tips	1.7 m	5'10"	1.97 m	6'6"	2125 mm	7'0"
Drum only	1.3 m	4'3"	1.61 m	5'3"	1.77 m	5'10"
Tips per Wheel	20		30		40	
Tip Height	158 mm	6.5"	178 mm	7"	178 mm	7"
Chopper Blades per Wheel	20		24		28	
Blade Height	152 mm	6"	158 mm	6"	158 mm	6"
Width of Two Pass Coverage	4.5 m	14'9"	4.78 m	15'8"	5.67 m	18'7"
GENERAL DIMENSIONS:						
Height (Overall)	3.8 m	12'8"	4.76 m	15'7"	4.85 m	15'11"
Height (Top of Cab)	3.4 m	11'3"	4.19 m	13'9"	4.3 m	14'1"
Wheel Base	3.35 m	11'0"	3.7 m	12'2"	4.55 m	14'11"
Overall Length with Dozer	7.85 m	25'7"	8.27 m	27'2"	10.18 m	33'5"
Width over Drums	3.33 m	10'11"	3.8 m	12'8"	4.18 m	14'1"
Ground Clearance	456 mm	1'5"	645 mm	2'1"	632 mm	2'1"
STRAIGHT BLADE:						
Width	3.65 m	12'0"	4.5 m	14'9"	5.19 m	17'0"
Height**	1.91 m	6'3"	1.91 m	6'3"	2.24 m	7'4"

\*Operating Weight includes coolant, full hydraulics, full fuel tank, all heaviest options and 82 kg (180 lb) operator.

\*\*Height (stripped top) — without ROPS cab, exhaust, seat back or other easily removed encumbrances.

<sup>1</sup> Meets Tier 3, Stage IIIA, Japan 2006 (Tier 3) equivalent emission standards.

<sup>2</sup> Meets Tier 4 Final, Stage IV and Japan 2014 (Tier 4 Final) emission standards.



**816F2**

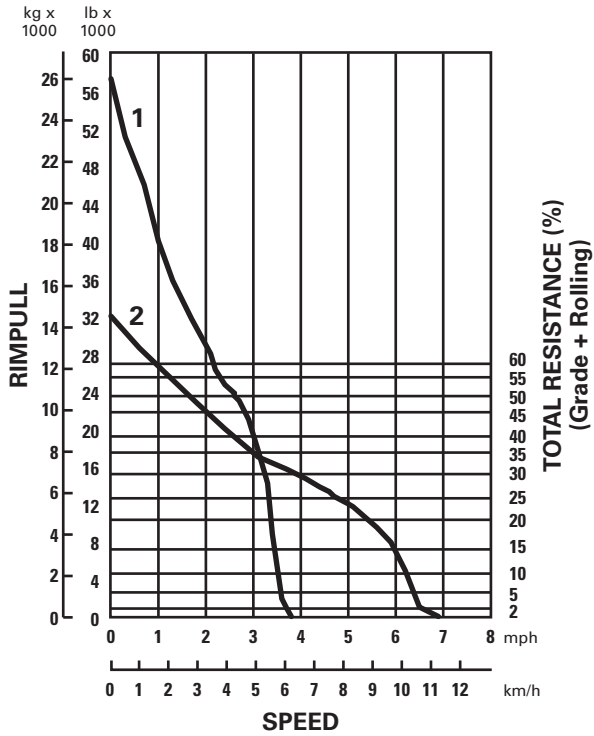

**KEY**  
1 – 1st Gear  
2 – 2nd Gear

826K

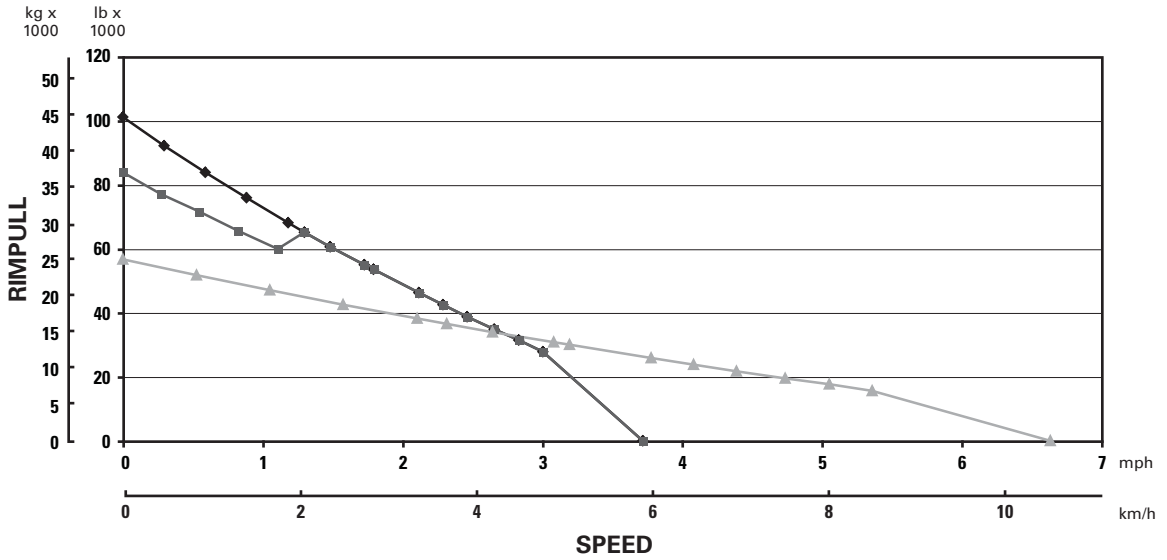

836K

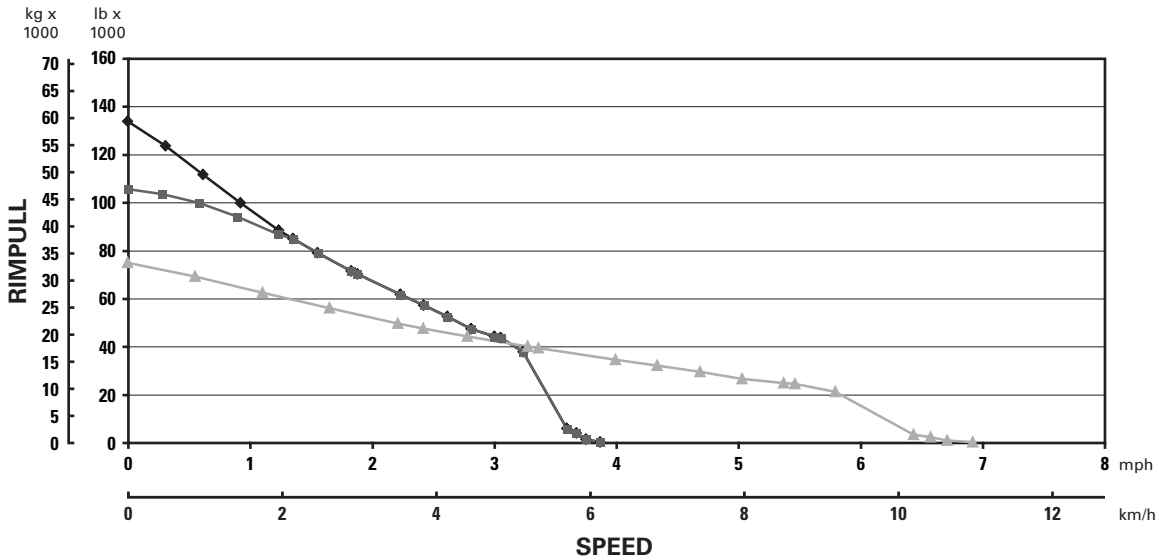

KEY  
 ◆ 1F CD  
 ■ 1F CD with PTS  
 ▲ 2F CD

<b>MODEL</b>	<b>816F2</b>		<b>826K</b>		<b>836K</b>	
Type	<b>Straight</b>		<b>Straight</b>		<b>Straight</b>	
Capacity**						
Earth	2.9 m <sup>3</sup>	<b>3.79 yd<sup>3</sup></b>	3.68 m <sup>3</sup>	<b>4.81 yd<sup>3</sup></b>	5 m <sup>3</sup>	<b>6.66 yd<sup>3</sup></b>
Refuse	11 m <sup>3</sup>	<b>14.39 yd<sup>3</sup></b>	13 m <sup>3</sup>	<b>17 yd<sup>3</sup></b>	19.8 m <sup>3</sup>	<b>25.9 yd<sup>3</sup></b>
Weight, Dozer*	2107 kg	<b>4645 lb</b>	2517 kg	<b>5549 lb</b>	3400 kg	<b>7650 lb</b>
General Dimensions: (Tractor and Dozer)						
Width	3.65 m	<b>12'0"</b>	4.5 m	<b>14'9"</b>	5.19 m	<b>17'0"</b>
Blade Dimensions:						
Width, End Bits	3.65 m	<b>12'0"</b>	4.5 m	<b>14'9"</b>	5.19 m	<b>17'0"</b>
Height, Trash Rack	1914 mm	<b>6'3"</b>	1940 mm	<b>6'4"</b>	2222 mm	<b>7'3"</b>

\*Total Bulldozer Arrangement.

\*\*Blade capacities determined by SAE recommended practice J1265.

<b>U-BLADE</b>	<b>816F2</b>		<b>826K</b>		<b>836K</b>	
<b>Blade:</b>						
Capacity (Refuse)	9.74 m <sup>3</sup>	<b>12.74 yd<sup>3</sup></b>	17.5 m <sup>3</sup>	<b>22.9 yd<sup>3</sup></b>	9.74 m <sup>3</sup>	<b>13 yd<sup>3</sup></b>
Cutting Width	3.73 m	<b>12'3"</b>	4.39 m	<b>14'5"</b>	3.73 m	<b>12'3"</b>
Weight, Installed (without Hydraulics)	—	—	2574 kg	<b>5675 lb</b>	3839 kg	<b>8465 lb</b>

<b>SEMI-U BLADE</b>	<b>816F2</b>		<b>826K</b>		<b>836K</b>	
<b>Blade:</b>						
Capacity (Refuse)	8.95 m <sup>3</sup>	<b>11.71 yd<sup>3</sup></b>	16 m <sup>3</sup>	<b>20.9 yd<sup>3</sup></b>	22.4 m <sup>3</sup>	<b>29.3 yd<sup>3</sup></b>
Cutting Width	3.71 m	<b>12'2"</b>	4.52 m	<b>14'10"</b>	5.31 m	<b>17'5"</b>
Weight, Installed (without Hydraulics)	—	—	2731 kg	<b>6021 lb</b>	3744 kg	<b>8256 lb</b>

**Features:**

Cat Waste Handling Wheel Loaders are equipped with the features and protection required in a demanding waste handling environment. These Caterpillar designed and built machines feature the following advantages:

- **Exceptional productivity** with fast cycle times for maximum production day-in day-out whether dozing, loading, stacking, or load and carry.
- **Protected work environment** enhances operator comfort, convenience and productivity.
- **Modified front frames** — (Standard on the 980H WHA) provide large cutouts that allows debris to fall out rather than packing and also provide easy access if cleaning is necessary.
- **Standard front drive guard and axle seal guards** (except 980H) protect from wire, string, strapping and other debris from wrapping and causing damage.
- **Front light guards** protect the lights from debris falling over the bucket spill plate.
- **Hinged crankcase and power train guards** help protect the engine and power train. The hinged design provides easy access for cleaning. (Powered guards available on some models.)
- **Standard waste application cooling system.** The improved, trash-resistant, multi-row module (IMRM) radiator, hood and engine enclosures work as a system to keep the radiator and engine compartment free of debris.
- **Trash resistant IMRM radiator** has six fins per inch (25.4 mm) and in-line tubes that resist plugging by allowing debris to pass through the core.
- **Hinged radiator prescreener** (966H and 972H) eliminates debris larger than what the radiator core will pass.
- **Hinged grill** (966H and 972H) allows access to hydraulic oil cooler and air conditioning condenser, which swing out for easy cleaning.

**Recommended Waste Handling Options**

- **Powered crankcase and power train guards** raise and lower at the flip of a switch allowing fast, easy and frequent cleanings.
- **High lift arrangement** increases bucket hinge pin height offering increased stacking and stockpiling capability. A critical feature when incoming volumes exceed conveyor capacity or floor space.
- **Traction control system (TCS)** option for 938H/IT38H provides maximum traction in slippery conditions. TCS electronically senses and limits wheel slip at each wheel independently.
- **Limited-slip differential** limits tire slip on both front and rear axles. Increases traction and reduces tire wear and scuffing in wet or dry conditions. Provides an alternative to the No SPIN differential which is not recommended due to increased tire wear, turning interference and poor tracking on dry surfaces.
- **Tire options:**
  - L-5 bias hard rock lug
  - L-5 slick
  - RL-5K Goodyear radials
  - XMINE Michelin radials (varies by model)
  - Foam-filled
- **Hitch guards** help protect components in hitch area from damage.
- **Reversing radiator fan** is hydraulically driven and can be reversed by a switch in the operator station or automatically by timer. Reduces need for cooling system cleaning and improves cooling capability.
- **Other guarding and options** are available. Contact your Cat dealer for information.

**Work Tools**

- **Refuse bucket** has excellent dozing and stockpiling capability. Large spill plate helps protect the machine from debris falling over the top of the bucket. Available in pin-on or quick coupler configurations.
- **Pallet forks** are ideal for handling refuse destined for further recycling or stacking refuse in landfills for covering.

- **Multi-purpose bucket** has the capability to clamp and sort large objects, doze cover material or other light dozing chores.
- **Quick coupler** increases versatility by allowing a single machine to utilize a wide variety of work tools in a host of applications.

<b>MODEL</b>	<b>926M WHA</b>		<b>930M WHA</b>		<b>938M WHA</b>	
Emission Standards	<b>Tier 4 Final***</b>		<b>Tier 4 Final***</b>		<b>Tier 4 Final***</b>	
Flywheel Power	110 kW	<b>148 hp</b>	117 kW	<b>157 hp</b>	136 kW	<b>182 hp</b>
Rated Power	114 kW	<b>153 hp</b>	122 kW	<b>166 hp</b>	140 kW	<b>190 hp</b>
Engine Model	<b>C7.1 ACERT</b>		<b>C7.1 ACERT</b>		<b>C7.1 ACERT</b>	
Rated Engine RPM	<b>1800</b>		<b>1800</b>		<b>1800</b>	
Bore	105 mm	<b>4.13"</b>	105 mm	<b>4.13"</b>	105 mm	<b>4.13"</b>
Stroke	135 mm	<b>5.31"</b>	135 mm	<b>5.31"</b>	135 mm	<b>5.31"</b>
No. Cylinders	<b>6</b>		<b>6</b>		<b>6</b>	
Displacement	7.01 L	<b>427 in<sup>3</sup></b>	7.01 L	<b>427 in<sup>3</sup></b>	7.01 L	<b>427 in<sup>3</sup></b>
Speeds Forward and Reverse	<b>km/h</b>	<b>mph</b>	<b>km/h</b>	<b>mph</b>	<b>km/h</b>	<b>mph</b>
1st	1.0-13.0	<b>0.6-8.0</b>	1.0-13.0	<b>0.6-8.0</b>	1.0-13.0	<b>0.6-8.0</b>
2nd	13.0	<b>8.0</b>	13.0	<b>8.0</b>	13.0	<b>8.0</b>
3rd	27.0	<b>17.0</b>	27.0	<b>17.0</b>	27.0	<b>17.0</b>
4th	40.0	<b>25.0</b>	40.0	<b>25.0</b>	40.0	<b>25.0</b>
Hydraulic Cycle Time*	<b>Seconds</b>		<b>Seconds</b>		<b>Seconds</b>	
Rated Load in Bucket:						
Raise	<b>5.5</b>		<b>5.1</b>		<b>5.5</b>	
Dump	<b>1.5</b>		<b>1.5</b>		<b>1.5</b>	
Lower (empty, float down)	<b>2.6</b>		<b>2.7</b>		<b>2.7</b>	
Total	<b>9.6</b>		<b>9.3</b>		<b>9.7</b>	
Tread Width**	1.93 m	<b>6'3"</b>	1.93 m	<b>6'3"</b>	2.08 m	<b>6'10"</b>
Width Over Tires**	2.54 m	<b>8'4"</b>	2.54 m	<b>8'4"</b>	2.69 m	<b>8'10"</b>
Ground Clearance**	397 mm	<b>1'4"</b>	397 mm	<b>1'4"</b>	386 mm	<b>1'3"</b>
Fuel Tank Capacity	195 L	<b>51.5 U.S. gal</b>	195 L	<b>51.5 U.S. gal</b>	195 L	<b>51.5 U.S. gal</b>
Hydraulic Tank Capacity	90 L	<b>23.8 U.S. gal</b>	90 L	<b>23.8 U.S. gal</b>	90 L	<b>23.8 U.S. gal</b>
Hinge Pin Height:						
Full Lift Std.	3907 mm	<b>12'9"</b>	3907 mm	<b>12'9"</b>	3969 mm	<b>13'0"</b>
High Lift	4400 mm	<b>14'5"</b>	4500 mm	<b>14'9"</b>	4550 mm	<b>14'11"</b>
Operating Weight up to:	18 800 kg	<b>41,447 lb</b>	19 000 kg	<b>41,888 lb</b>	20 200 kg	<b>44,533 lb</b>

\*With standard lift arms.

\*\*With standard tires.

\*\*\*Meets Tier 4 Final, Stage IV and Japan 2014 (Tier 4 Final) emission standards.

**NOTE:** Dimensions listed are for a machine configured with Fusion work tool, counterweights, additional guarding, 80 kg (176 lb) operator, and Michelin 20.5 R25 (L-3) XHA2 tires.

MODEL	924K WHA		930K WHA		938K WHA	
Emission Standards	Tier 3 Equivalent**		Tier 3 Equivalent***		Tier 3 Equivalent***	
Flywheel Power	102 kW	137 hp	116 kW	156 hp	136 kW	182 hp
Rated Power	105 kW	141 hp	119 kW	160 hp	140 kW	188 hp
Engine Model	C7.1 ACERT		C7.1 ACERT		C7.1 ACERT	
Rated Engine RPM	1800		1800		1800	
Bore	105 mm	4.13"	105 mm	4.13"	105 mm	4.13"
Stroke	135 mm	5.31"	135 mm	5.31"	135 mm	5.31"
No. Cylinders	6		6		6	
Displacement	7.0 L	428 in <sup>3</sup>	7.0 L	428 in <sup>3</sup>	7.0 L	428 in <sup>3</sup>
Speeds Forward and Reverse	km/h	mph	km/h	mph	km/h	mph
1st	1.0-13.0	0.6-8.0	1.0-13.0	0.6-8.0	1.0-13.0	0.6-8.0
2nd	13.0	8.0	13.0	8.0	13.0	8.0
3rd	27.0	17.0	27.0	17.0	27.0	17.0
4th	40.0	25.0	40.0	25.0	40.0	25.0
Hydraulic Cycle Time*	Seconds		Seconds		Seconds	
Rated Load in Bucket:						
Raise	5.4		5.1		5.5	
Dump	1.5		1.5		1.5	
Lower (empty, float down)	2.6		2.7		2.7	
Total	9.5		9.3		9.7	
Tread Width**	1930 mm	6'3"	1930 mm	6'3"	2065 mm	6'9"
Width Over Tires**	2540 mm	8'4"	2540 mm	8'4"	2675 mm	8'9"
Ground Clearance**	397 mm	1'3"	397 mm	1'3"	386 mm	1'3"
Fuel Tank Capacity	195 L	51.5 U.S. gal	195 L	51.5 U.S. gal	195 L	51.5 U.S. gal
Hydraulic Tank Capacity	90 L	23.8 U.S. gal	90 L	23.8 U.S. gal	90 L	23.8 U.S. gal
Hinge Pin Height:						
Full Lift Std.	3853 mm	12'7"	3907 mm	12'9"	3969 mm	13'0"
High Lift	—		4500 mm	14'9"	4550 mm	14'11"
Operating Weight up to:						
Standard Lift	18 800 kg	41,447 lb	19 000 kg	41,888 lb	20 200 kg	44,533 lb

\*With standard lift arms.

\*\*With standard tires.

\*\*\*Meets Tier 3, Stage IIIA, Japan 2006 (Tier 3) equivalent emission standards.

NOTE: Dimensions listed are for a machine configured with general purpose pin on buckets, bolt-on cutting edges, optional counterweights, 80 kg (176 lb) operator, and Michelin 20.5 R25 (L-3) XHA2 tires.

<b>MODEL</b>	<b>950M WHA</b>		<b>962M WHA</b>		<b>966M WHA</b>	
Emission Standards	<b>Tier 4 Final*</b>		<b>Tier 4 Final*</b>		<b>Tier 4 Final*</b>	
Maximum Engine: Net	171 kW	<b>230 hp</b>	186 kW	<b>250 hp</b>	206 kW	<b>276 hp</b>
Gross	187 kW	<b>250 hp</b>	202 kW	<b>271 hp</b>	232 kW	<b>311 hp</b>
Engine Model	<b>C7.1 ACERT</b>		<b>C7.1 ACERT</b>		<b>C9.3 ACERT</b>	
Maximum Net Power Engine RPM	<b>2100</b>		<b>2100</b>		<b>1700</b>	
Bore	105 mm	<b>4.1"</b>	105 mm	<b>4.1"</b>	115 mm	<b>4.53"</b>
Stroke	135 mm	<b>5.3"</b>	135 mm	<b>5.3"</b>	149 mm	<b>5.87"</b>
No. Cylinders	<b>6</b>		<b>6</b>		<b>6</b>	
Displacement	7.01 L	<b>427.8 in<sup>3</sup></b>	7.01 L	<b>427.8 in<sup>3</sup></b>	9.3 L	<b>568 in<sup>3</sup></b>
Speeds Forward:	<b>km/h</b>	<b>mph</b>	<b>km/h</b>	<b>mph</b>	<b>km/h</b>	<b>mph</b>
1st	6.9	<b>4.3</b>	6.9	<b>4.3</b>	6.5	<b>4.0</b>
2nd	12.0	<b>7.5</b>	12.0	<b>7.5</b>	13.0	<b>8.1</b>
3rd	19.3	<b>12.0</b>	19.3	<b>12.0</b>	23.5	<b>14.6</b>
4th	25.7	<b>16.0</b>	25.7	<b>16.0</b>	39.5	<b>24.5</b>
5th	39.5	<b>24.5</b>	39.5	<b>24.5</b>	—	
Speeds Reverse:	<b>km/h</b>	<b>mph</b>	<b>km/h</b>	<b>mph</b>	<b>km/h</b>	<b>mph</b>
1st	6.9	<b>4.3</b>	6.9	<b>4.3</b>	7.1	<b>4.4</b>
2nd	12.0	<b>7.5</b>	12.0	<b>7.5</b>	14.4	<b>8.9</b>
3rd	25.7	<b>16.0</b>	25.7	<b>16.0</b>	25.9	<b>16.1</b>
4th	—		—		39.0	<b>24.2</b>
Hydraulic Cycle Time, Rated Load in Bucket:	<b>Seconds</b>		<b>Seconds</b>		<b>Seconds</b>	
Raise	<b>5.3</b>		<b>5.4</b>		<b>5.5</b>	
Dump	<b>1.5</b>		<b>1.5</b>		<b>1.4</b>	
Lower (Empty, Float Down)	<b>2.3</b>		<b>2.7</b>		<b>2.6</b>	
Total	<b>9.1</b>		<b>9.6</b>		<b>9.5</b>	
Tread Width	2140 mm	<b>7'0"</b>	2140 mm	<b>7'0"</b>	2230 mm	<b>7'4"</b>
Width Over Tires	2790 mm	<b>9'2"</b>	2790 mm	<b>9'2"</b>	2991 mm	<b>9'10"</b>
Ground Clearance	385 mm	<b>1'3"</b>	385 mm	<b>1'3"</b>	476 mm	<b>1'7"</b>
Fuel Tank Capacity	275 L	<b>72.6 U.S. gal</b>	275 L	<b>72.6 U.S. gal</b>	303 L	<b>80.0 U.S. gal</b>
DEF Tank Capacity	16 L	<b>4.2 U.S. gal</b>	16 L	<b>4.2 U.S. gal</b>	16.8 L	<b>4.4 U.S. gal</b>
Hydraulic Tank Capacity	125 L	<b>33 U.S. gal</b>	125 L	<b>33 U.S. gal</b>	125 L	<b>33.0 U.S. gal</b>

\*Meets Tier 4 Final, Stage IV and Japan 2014 (Tier 4 Final) emission standards.

**NOTE:** Net Engine Power is provided according to SAE J1349 and ISO 9249. Gross Engine Power is provided according to SAE J1995. Machines may only be available in certain regions. Contact your local Cat dealer for product availability.

<b>MODEL</b>	<b>972M WHA</b>		<b>980M WHA</b>	
Emission Standards	<b>Tier 4 Final*</b>		<b>Tier 4 Final*</b>	
Maximum Engine: Net	223 kW	<b>299 hp</b>	288 kW	<b>386 hp</b>
Gross	251 kW	<b>337 hp</b>	317 kW	<b>425 hp</b>
Engine Model	<b>C9.3 ACERT</b>		<b>C13 ACERT</b>	
Maximum Net Power Engine RPM	<b>1700</b>		<b>1700</b>	
Bore	115 mm	<b>4.53"</b>	130 mm	<b>5.1"</b>
Stroke	149 mm	<b>5.87"</b>	157 mm	<b>6.2"</b>
No. Cylinders	<b>6</b>		<b>6</b>	
Displacement	9.3 L	<b>568 in<sup>3</sup></b>	12.5 L	<b>762.8 in<sup>3</sup></b>
Speeds Forward:	<b>km/h</b>	<b>mph</b>	<b>km/h</b>	<b>mph</b>
1st	6.7	<b>4.2</b>	6.9	<b>4.3</b>
2nd	13.1	<b>8.1</b>	13.3	<b>8.3</b>
3rd	23.2	<b>14.4</b>	23.5	<b>14.6</b>
4th	39.5	<b>24.5</b>	39.5	<b>24.5</b>
5th	—		—	
Speeds Reverse:	<b>km/h</b>	<b>mph</b>	<b>km/h</b>	<b>mph</b>
1st	7.6	<b>4.7</b>	7.8	<b>4.8</b>
2nd	15.0	<b>8.9</b>	15.2	<b>9.4</b>
3rd	26.5	<b>16.5</b>	26.9	<b>16.7</b>
4th	39.5	<b>24.5</b>	39.5	<b>24.5</b>
Hydraulic Cycle Time, Rated Load in Bucket:	<b>Seconds</b>		<b>Seconds</b>	
Raise	<b>5.5</b>		<b>5.3</b>	
Dump	<b>1.5</b>		<b>1.7</b>	
Lower (Empty, Float Down)	<b>3.1</b>		<b>3.1</b>	
Total	<b>10.1</b>		<b>10.1</b>	
Tread Width	2230 mm	<b>7'4"</b>	2440 mm	<b>8'0"</b>
Width Over Tires	2991 mm	<b>9'10"</b>	3265 mm	<b>10'9"</b>
Ground Clearance	476 mm	<b>1'7"</b>	453 mm	<b>1'6"</b>
Fuel Tank Capacity	303 L	<b>80.0 U.S. gal</b>	426 L	<b>112.5 U.S. gal</b>
DEF Tank Capacity	16.8 L	<b>4.4 U.S. gal</b>	21 L	<b>5.5 U.S. gal</b>
Hydraulic Tank Capacity	125 L	<b>33.0 U.S. gal</b>	180 L	<b>48 U.S. gal</b>

\*Meets Tier 4 Final, Stage IV and Japan 2014 (Tier 4 Final) emission standards.

**NOTE:** Net Engine Power is provided according to SAE J1349 and ISO 9249. Gross Engine Power is provided according to SAE J1995. Machines may only be available in certain regions. Contact your local Cat dealer for product availability.



<b>MODEL</b>	<b>950K WHA</b>		<b>962K WHA</b>	
Emission Standards	<b>Tier 4 Interim Equivalent*</b>		<b>Tier 4 Interim Equivalent*</b>	
Peak Net Power	157 kW	<b>210 hp</b>	165 kW	<b>222 hp</b>
Peak Gross Power	173 kW	<b>232 hp</b>	181 kW	<b>243 hp</b>
Engine Model	<b>C7.1 ACERT</b>		<b>C7.1 ACERT</b>	
Peak Net Power Engine RPM	<b>1900</b>		<b>1900</b>	
Bore	105 mm	<b>4.1"</b>	105 mm	<b>4.1"</b>
Stroke	135 mm	<b>5.3"</b>	135 mm	<b>5.3"</b>
No. Cylinders	<b>6</b>		<b>6</b>	
Displacement	7.01 L	<b>427.8 in<sup>3</sup></b>	7.01 L	<b>427.8 in<sup>3</sup></b>
Speeds Forward	<b>km/h</b>	<b>mph</b>	<b>km/h</b>	<b>mph</b>
1st	6.9	<b>4.3</b>	6.9	<b>4.3</b>
2nd	12.9	<b>8.0</b>	12.9	<b>8.0</b>
3rd	22.7	<b>14.1</b>	22.7	<b>14.1</b>
4th	37.9	<b>23.6</b>	37.9	<b>23.6</b>
Speeds Reverse				
1st	7.5	<b>4.7</b>	7.5	<b>4.7</b>
2nd	14.1	<b>8.8</b>	14.1	<b>8.8</b>
3rd	24.8	<b>15.4</b>	24.8	<b>15.4</b>
4th	39.8	<b>24.7</b>	39.8	<b>24.7</b>
Hydraulic Cycle Time Rated Load in Bucket:	<b>Seconds</b>		<b>Seconds</b>	
Raise	<b>5.9</b>		<b>5.9</b>	
Dump	<b>1.8</b>		<b>1.8</b>	
Lower (empty, float down)	<b>2.5</b>		<b>2.5</b>	
Total	<b>10.0</b>		<b>10.0</b>	
Tread Width	2.14 m	<b>7'0"</b>	2.14 m	<b>7'0"</b>
Width Over Tires	2.79 m	<b>9'2"</b>	2.79 m	<b>9'2"</b>
Ground Clearance	397 mm	<b>1'3"</b>	397 mm	<b>1'3"</b>
Fuel Tank Capacity	314 L	<b>83 U.S. gal</b>	314 L	<b>83 U.S. gal</b>
Hydraulic Tank Capacity	137 L	<b>36 U.S. gal</b>	137 L	<b>36 U.S. gal</b>
Hydraulic System Capacity (includes tank)	189 L	<b>50 U.S. gal</b>	189 L	<b>50 U.S. gal</b>

\*Meets Tier 4 Interim, Stage IIIB, and Japan 2011 (Tier 4 Interim) equivalent emission standards.

**NOTE:** Machines may only be available in certain regions. Contact your local Cat dealer for product availability.

**NOTE:** Net Engine Power is provided according to SAE J1349 and ISO 9249. Gross Engine Power is provided according to SAE J1995.

MODEL	966K WHA		972K WHA		980K WHA	
Emission Standards	Tier 4 Interim Equivalent*		Tier 4 Interim Equivalent*		Tier 4 Interim Equivalent*	
Peak Net Power	199 kW	267 hp	215 kW	289 hp	274 kW	369 hp
Peak Gross Power	222 kW	296 hp	237 kW	318 hp	303 kW	407 hp
Engine Model	C9.3 ACERT		C9.3 ACERT		C13 ACERT	
Peak Net Power Engine RPM	1800		1800		1600	
Bore	115 mm	4.5"	115 mm	4.5"	130 mm	5.1"
Stroke	149 mm	5.9"	149 mm	5.9"	157 mm	6.2"
No. Cylinders	6		6		6	
Displacement	9.3 L	568 in <sup>3</sup>	9.3 L	568 in <sup>3</sup>	12.5 L	762.8 in <sup>3</sup>
Speeds Forward	km/h	mph	km/h	mph	km/h	mph
1st	6.7	4.2	7.0	4.4	6.9	4.3
2nd	12.6	7.8	12.5	7.8	12.2	7.6
3rd	22.4	13.9	21.4	13.3	21.3	13.2
4th	37.4	23.2	36.9	22.9	37.2	23.1
Speeds Reverse						
1st	7.8	4.9	8.0	5.0	7.8	4.8
2nd	13.7	8.5	14.3	8.9	13.8	8.6
3rd	23.5	14.6	24.5	15.2	24.2	15.1
4th	38.5	23.9	42.2	26.2	42.4	26.3
Hydraulic Cycle Time						
Rated Load in Bucket:	Seconds		Seconds		Seconds	
Raise	5.9		5.9		6.4	
Dump	1.5		2.0		1.7	
Lower (Empty, Float Down)	2.4		2.4		3.3	
Total	9.8		10.3		11.4	
Tread Width	2.23 m	7'4"	2.23 m	7'4"	2.44 m	8'0"
Width Over Tires	3.01 m	9'11"	3.02 m	9'11"	3307 mm	10'9"
Ground Clearance	475 mm	1'6"	475 mm	1'6"	460 mm	1'6"
Fuel Tank Capacity	381 L	101 U.S. gal	381 L	101 U.S. gal	447 L	118.1 U.S. gal
Hydraulic Tank Capacity	137 L	36 U.S. gal	137 L	36 U.S. gal	156 L	41 U.S. gal
Hydraulic System Capacity (includes tank)	200 L	52 U.S. gal	200 L	52 U.S. gal	271 L	72 U.S. gal

\*Meets Tier 4 Interim, Stage IIIB, and Japan 2011 (Tier 4 Interim) equivalent emission standards.

**NOTE:** Machines may only be available in certain regions. Contact your local Cat dealer for product availability.

**NOTE:** Net Engine Power is provided according to SAE J1349 and ISO 9249. Gross Engine Power is provided according to SAE J1995.

<b>MODEL</b>	<b>950M WHA</b>		<b>950L WHA</b>		<b>962M WHA</b>		<b>962L WHA</b>	
Emission Standards	<b>Tier 3 Equivalent*</b>		<b>Tier 3 Equivalent*</b>		<b>Tier 3 Equivalent*</b>		<b>Tier 3 Equivalent*</b>	
Maximum Engine Power: Net	185 kW	<b>248 hp</b>	185 kW	<b>248 hp</b>	185 kW	<b>248 hp</b>	185 kW	<b>248 hp</b>
Gross	196 kW	<b>262 hp</b>	196 kW	<b>262 hp</b>	196 kW	<b>262 hp</b>	196 kW	<b>262 hp</b>
Engine Model	<b>C7.1 ACERT</b>		<b>C7.1 ACERT</b>		<b>C7.1 ACERT</b>		<b>C7.1 ACERT</b>	
Maximum Net Power Engine RPM	<b>2000</b>		<b>2000</b>		<b>2000</b>		<b>2000</b>	
Bore	105 mm	<b>4.1"</b>	105 mm	<b>4.1"</b>	105 mm	<b>4.1"</b>	105 mm	<b>4.1"</b>
Stroke	135 mm	<b>5.3"</b>	135 mm	<b>5.3"</b>	135 mm	<b>5.3"</b>	135 mm	<b>5.3"</b>
No. Cylinders	<b>6</b>		<b>6</b>		<b>6</b>		<b>6</b>	
Displacement	7.01 L	<b>427.8 in<sup>3</sup></b>	7.01 L	<b>427.8 in<sup>3</sup></b>	7.01 L	<b>427.8 in<sup>3</sup></b>	7.01 L	<b>427.8 in<sup>3</sup></b>
Speeds Forward:	<b>km/h</b>	<b>mph</b>	<b>km/h</b>	<b>mph</b>	<b>km/h</b>	<b>mph</b>	<b>km/h</b>	<b>mph</b>
1st	6.9	<b>4.3</b>	6.9	<b>4.3</b>	6.9	<b>4.3</b>	6.9	<b>4.3</b>
2nd	12.0	<b>7.5</b>	12.0	<b>7.5</b>	12.0	<b>7.5</b>	12.0	<b>7.5</b>
3rd	19.3	<b>12.0</b>	19.3	<b>12.0</b>	19.3	<b>12.0</b>	19.3	<b>12.0</b>
4th	25.7	<b>16.0</b>	25.7	<b>16.0</b>	25.7	<b>16.0</b>	25.7	<b>16.0</b>
5th	39.5	<b>24.5</b>	39.5	<b>24.5</b>	39.5	<b>24.5</b>	39.5	<b>24.5</b>
Speeds Reverse:	<b>km/h</b>	<b>mph</b>	<b>km/h</b>	<b>mph</b>	<b>km/h</b>	<b>mph</b>	<b>km/h</b>	<b>mph</b>
1st	6.9	<b>4.3</b>	6.9	<b>4.3</b>	6.9	<b>4.3</b>	6.9	<b>4.3</b>
2nd	12.0	<b>7.5</b>	12.0	<b>7.5</b>	12.0	<b>7.5</b>	12.0	<b>7.5</b>
3rd	25.7	<b>16.0</b>	25.7	<b>16.0</b>	25.7	<b>16.0</b>	25.7	<b>16.0</b>
Hydraulic Cycle Time, Rated Load in Bucket:	<b>Seconds</b>		<b>Seconds</b>		<b>Seconds</b>		<b>Seconds</b>	
Raise from Carry Position	<b>5.3</b>		<b>5.3</b>		<b>5.4</b>		<b>5.3</b>	
Dump, at Maximum Raise	<b>1.5</b>		<b>1.4</b>		<b>1.5</b>		<b>1.4</b>	
Lower (Empty, Float Down)	<b>2.3</b>		<b>2.8</b>		<b>2.7</b>		<b>2.8</b>	
Total	<b>9.1</b>		<b>9.5</b>		<b>9.6</b>		<b>9.5</b>	
Tread Width	2140 mm	<b>7'0"</b>	2140 mm	<b>7'0"</b>	2140 mm	<b>7'0"</b>	2140 mm	<b>7'0"</b>
Width Over Tires	2790 mm	<b>9'2"</b>	2790 mm	<b>9'2"</b>	2790 mm	<b>9'2"</b>	2790 mm	<b>9'2"</b>
Ground Clearance	385 mm	<b>1'3"</b>	385 mm	<b>1'3"</b>	385 mm	<b>1'3"</b>	385 mm	<b>1'3"</b>
Fuel Tank Capacity	275 L	<b>72.6</b>	275 L	<b>72.6</b>	275 L	<b>72.6</b>	275 L	<b>72.6</b>
		<b>U.S. gal</b>		<b>U.S. gal</b>		<b>U.S. gal</b>		<b>U.S. gal</b>
Hydraulic Tank Capacity	125 L	<b>33 U.S. gal</b>	125 L	<b>33 U.S. gal</b>	125 L	<b>33 U.S. gal</b>	125 L	<b>33 U.S. gal</b>

\*Meets Tier 3, Stage IIIA, Japan 2006 (Tier 3) equivalent emission standards.

**NOTE:** Net Engine Power is provided according to SAE J1349 and ISO 9249. Gross Engine Power is provided according to SAE J1995. Machines may only be available in certain regions. Contact your local Cat dealer for product availability.

MODEL	966L WHA 966M WHA		972L WHA 972M WHA		980L WHA 980M WHA	
Emission Standards	Tier 2 Equivalent or Tier 3 Equivalent*		Tier 2 Equivalent or Tier 3 Equivalent*		Tier 2 Equivalent or Tier 3 Equivalent*	
Maximum Engine Power: Net	207 kW	<b>278 hp</b>	222 kW	<b>298 hp</b>	278 kW	<b>373 hp</b>
Gross	230 kW	<b>308 hp</b>	246 kW	<b>330 hp</b>	307 kW	<b>412 hp</b>
Engine Model	<b>C9.3 ACERT</b>		<b>C9.3 ACERT</b>		<b>C13 ACERT</b>	
Maximum Net Power Engine RPM	<b>1700</b>		<b>1800</b>		<b>1800</b>	
Bore	115 mm	<b>4.53"</b>	115 mm	<b>4.53"</b>	130 mm	<b>5.1"</b>
Stroke	149 mm	<b>5.87"</b>	149 mm	<b>5.87"</b>	157 mm	<b>6.2"</b>
No. Cylinders	<b>6</b>		<b>6</b>		<b>6</b>	
Displacement	9.3 L	<b>568 in<sup>3</sup></b>	9.3 L	<b>568 in<sup>3</sup></b>	12.5 L	<b>762.8 in<sup>3</sup></b>
Speeds Forward:	<b>km/h</b>	<b>mph</b>	<b>km/h</b>	<b>mph</b>	<b>km/h</b>	<b>mph</b>
1st	6.5	<b>4.0</b>	6.7	<b>4.2</b>	6.9	<b>4.3</b>
2nd	13.0	<b>8.1</b>	13.1	<b>8.1</b>	13.3	<b>8.3</b>
3rd	23.5	<b>14.6</b>	23.2	<b>14.4</b>	23.5	<b>14.6</b>
4th	39.5	<b>24.5</b>	39.5	<b>24.5</b>	39.5	<b>24.5</b>
Speeds Reverse:	<b>km/h</b>	<b>mph</b>	<b>km/h</b>	<b>mph</b>	<b>km/h</b>	<b>mph</b>
1st	7.1	<b>4.4</b>	7.6	<b>4.7</b>	7.8	<b>4.8</b>
2nd	14.4	<b>8.9</b>	15.0	<b>8.9</b>	15.2	<b>9.4</b>
3rd	25.9	<b>16.1</b>	26.5	<b>16.5</b>	26.9	<b>16.7</b>
4th	39.0	<b>24.2</b>	39.5	<b>24.5</b>	39.5	<b>24.5</b>
Hydraulic Cycle Time, Rated Load in Bucket:	<b>Seconds</b>		<b>Seconds</b>		<b>Seconds</b>	
Raise from Carry Position	<b>5.5</b>		<b>5.5</b>		<b>5.3</b>	
Dump, at Maximum Raise	<b>1.4</b>		<b>1.5</b>		<b>1.7</b>	
Lower (Empty, Float Down)	<b>2.6</b>		<b>3.1</b>		<b>3.1</b>	
Total	<b>9.5</b>		<b>10.1</b>		<b>10.1</b>	
Tread Width	2230 mm	<b>7'4"</b>	2230 mm	<b>7'4"</b>	2440 mm	<b>8'0"</b>
Width Over Tires	2991 mm	<b>9'10"</b>	2991 mm	<b>9'10"</b>	3265 mm	<b>10'9"</b>
Ground Clearance	476 mm	<b>1'7"</b>	476 mm	<b>1'7"</b>	453 mm	<b>1'6"</b>
Fuel Tank Capacity	303 L	<b>80.0 U.S. gal</b>	303 L	<b>80.0 U.S. gal</b>	426 L	<b>112.5 U.S. gal</b>
Hydraulic Tank Capacity	125 L	<b>33.0 U.S. gal</b>	125 L	<b>33.0 U.S. gal</b>	180 L	<b>48 U.S. gal</b>

\*Products available to meet Tier 2/Stage II/Japan 2001 (Tier 2) equivalent OR Tier 3/Stage IIIA/Japan 2006 (Tier 3) equivalent emission standards.

**NOTE:** Net Engine Power is provided according to SAE J1349 and ISO 9249. Gross Engine Power is provided according to SAE J1995. Machines may only be available in certain regions. Contact your local Cat dealer for product availability.

<b>MODEL</b>	<b>950H WHA</b>		<b>962H WHA</b>	
Emission Standards	Tier 3 Equivalent***		Tier 3 Equivalent***	
Peak Net Power	147 kW	<b>197 hp</b>	156 kW	<b>209 hp</b>
Peak Gross Power	162 kW	<b>217 hp</b>	172 kW	<b>231 hp</b>
Engine Model	<b>C7 ACERT</b>		<b>C7 ACERT</b>	
Peak Net Power Engine RPM	<b>1800</b>		<b>1800</b>	
Bore	110 mm	<b>4.3"</b>	110 mm	<b>4.3"</b>
Stroke	127 mm	<b>5"</b>	127 mm	<b>5"</b>
No. Cylinders	<b>6</b>		<b>6</b>	
Displacement	7.2 L	<b>439 in<sup>3</sup></b>	7.2 L	<b>439 in<sup>3</sup></b>
Speeds Forward	<b>km/h</b>	<b>mph</b>	<b>km/h</b>	<b>mph</b>
1st	6.9	<b>4.3</b>	7.0	<b>4.4</b>
2nd	12.7	<b>7.9</b>	13.0	<b>8.1</b>
3rd	22.3	<b>13.9</b>	22.6	<b>14.0</b>
4th	37.0	<b>23.0</b>	38.0	<b>23.6</b>
Speeds Reverse				
1st	7.6	<b>4.7</b>	7.6	<b>4.7</b>
2nd	13.9	<b>8.6</b>	13.9	<b>8.6</b>
3rd	24.5	<b>15.2</b>	24.5	<b>15.2</b>
4th	40.5	<b>24.9</b>	40.0	<b>24.9</b>
Hydraulic Cycle Time*				
Rated Load in Bucket:	<b>Seconds</b>		<b>Seconds</b>	
Raise	<b>6.2</b>		<b>6.2</b>	
Dump	<b>2.0</b>		<b>2.0</b>	
Lower (empty, float down)	<b>2.5</b>		<b>2.5</b>	
Total	<b>10.7</b>		<b>10.7</b>	
Tread Width**	2.14 m	<b>7'0"</b>	2.14 m	<b>7'0"</b>
Width Over Tires**	2.79 m	<b>9'2"</b>	2.79 m	<b>9'2"</b>
Ground Clearance**	412 mm	<b>16"</b>	412 mm	<b>16"</b>
Fuel Tank Capacity	264 L	<b>70 U.S. gal</b>	264 L	<b>70 U.S. gal</b>
Hydraulic Tank Capacity	110 L	<b>29 U.S. gal</b>	110 L	<b>29 U.S. gal</b>
Hinge Pin Height:				
Full Lift Std.	3.99 m	<b>13'1"</b>	3.99 m	<b>13'1"</b>
High Lift with L-5 tires	4.54 m	<b>14'10"</b>	—	
Operating weight up to:	19 213 kg	<b>42,365 lb</b>	20 269 kg	<b>44,693 lb</b>

\*With standard lift arms.

\*\*With standard tires.

\*\*\*Meets Tier 3, Stage IIIA, Japan 2006 (Tier 3) equivalent emission standards.

NOTE: Not available in all regions. Contact your local Cat dealer for product availability.

NOTE: Net Engine Power is provided according to SAE J1349 and ISO 9249. Gross Engine Power is provided according to SAE J1995.

MODEL	966H WHA		972H WHA		980H WHA	
Emission Standards	Tier 3 Equivalent***		Tier 3 Equivalent***		Tier 3 Equivalent***	
Peak Net Power	195 kW	262 hp	214 kW	287 hp	237 kW	318 hp
Peak Gross Power	211 kW	283 hp	232 kW	311 hp	261 kW	351 hp
Engine Model	C11 ACERT		C13 ACERT		C15 ACERT	
Peak Net Power Engine RPM	1800		1800		1800	
Bore	130 mm	5.1"	130 mm	5.1"	137 mm	5.4"
Stroke	140 mm	5.5"	157 mm	6.2"	171 mm	6.75"
No. Cylinders	6		6		6	
Displacement	11.1 L	677 in <sup>3</sup>	12.5 L	763 in <sup>3</sup>	15.2 L	928 in <sup>3</sup>
Speeds Forward	km/h	mph	km/h	mph	km/h	mph
1st	6.7	4.2	7.2	4.5	6.6	4.1
2nd	12.6	7.8	12.6	7.8	11.8	7.3
3rd	22.1	13.7	21.4	13.3	20.7	12.9
4th	37.4	23.2	36.9	22.9	36.3	22.6
Speeds Reverse						
1st	7.4	4.6	8.2	5.1	7.6	4.7
2nd	13.7	8.6	14.2	8.8	13.5	8.4
3rd	23.4	15.1	24.3	15.1	23.7	14.7
4th	37.4	23.2	38.8	24.0	41.5	25.8
Hydraulic Cycle Time*						
Rated Load in Bucket:	Seconds		Seconds		Seconds	
Raise	5.9		5.9		6.0	
Dump	1.6		2.1		2.0	
Lower (empty, float down)	2.4		2.4		3.4	
Total	9.9		10.4		11.4	
Tread Width**	2.23 m	7'4"	2.23 m	7'4"	2.44 m	8'0"
Width Over Tires**	3.00 m	9'10"	3.00 m	9'10"	3.18 m	10'5"
Ground Clearance**	434 mm	17"	434 mm	17"	430 mm	16.9"
Fuel Tank Capacity	380 L	100 U.S. gal	380 L	100 U.S. gal	453 L	120 U.S. gal
Hydraulic Tank Capacity	110 L	29 U.S. gal	110 L	29 U.S. gal	125 L	33 U.S. gal
Hinge Pin Height:						
Full Lift Std.	4.23 m	13'10"	4.87 m	14'8"	4.51 m	14'9"
High Lift with L-5 tires	4.79 m	15'8"	4.81 m	15'9"	4.75 m	15'7"
Operating weight up to:	24 237 kg	53,443 lb	26 051 kg	57,442 lb	31 599 kg	69,676 lb

\*With standard lift arms.

\*\*With standard tires.

\*\*\*Meets Tier 3, Stage IIIA, Japan 2006 (Tier 3) equivalent emission standards.

NOTE: Not available in all regions. Contact your local Cat dealer for product availability.

NOTE: Net Engine Power is provided according to SAE J1349 and ISO 9249. Gross Engine Power is provided according to SAE J1995.

**WORK TOOLS**

As described in the opening statements of this section, the waste stream can consist of many different types of materials sometimes all blended together. For that reason, work tools become a very important part of moving,

sorting, and dozing in waste applications. (Continue to consider the thought process of; “what is the application and material(s) you will work with — then, what tool(s) will accomplish your objectives, and finally, what machine(s) will utilize that tool to perform in that application?”)

**Wheel Loader Work Tools**

MODEL	924K, 926M	930K, 930M	938K, 938M	950M, 962M, 950L, 962L, 950K, 962K, 950H, 962H	966M, 972M, 966L, 972L, 966K, 972K, 966H, 972H	980M, 980L, 980K, 980H
Bucket — Load & Carry	x	x	x	x	x	x
Bucket — Dozing	x	x	x	x	x	x
Bucket — Multi-Purpose	x	x	x	x	x	
Bucket — Waste Handling*	x	x	x	x	x	x

\*The “Waste Handling” bucket is a current bucket that is being phased out and replaced by the Load & Carry and Dozing buckets. All are in the current price lists.

**NOTE:** Other attachments available upon request. Contact your Cat dealer.

**NOTE:** Learn more about available work tools @ WorkTool Central: <https://dealer.cat.com/products/wtc>.

**Excavator Work Tools**

MODEL	308E CR	315D L, 316E L	318E	319D L, 319D LN	M313D, M315D	M316D, M318D, M322D	M318D MH, M322D MH	320E L, 320E LRR, 321D CR, 323D	320C MH	M322D MH	324D, 324E
Grapple — Contractors’	x	x	x	x	x	x	x	x			x
Grapple — Demolition and Sorting		x	x	x	x	x		x			x
Grapple — Orange Peel							x		x	x	
Grapple — Trash		x	x	x	x	x		x			x

**NOTE:** Normal Waste Applications utilize the Trash, Sorting, and Orange Peel Grapples. Depending on the application, these work tools might be advisable.

**NOTE:** Learn more about available work tools in the *Hydromechanical Work Tools* chapter of the *Performance Handbook*.

**NOTE:** Learn more about available work tools @ WorkTool Central: <https://dealer.cat.com/products/wtc>.

(Chart continued on next page)

## Excavator Work Tools (cont'd)

MODEL	M325D MH, 320C MH	329D, 329E	336D, 336E	MH3049	345D, 349D, 349E	345C MH	MH3059	365C L	374D	385C	390D
Grapple — Contractors'		x	x		x			x	x	x	x
Grapple — Demolition and Sorting		x	x		x						
Grapple — Orange Peel	x			x		x	x				
Grapple — Trash		x	x		x						

**NOTE:** Normal Waste Applications utilize the Trash, Sorting, and Orange Peel Grapples. Depending on the application, these work tools might be advisable.

**NOTE:** Learn more about available work tools in the *Hydromechanical Work Tools* chapter of the *Performance Handbook*.

**NOTE:** Learn more about available work tools @ WorkTool Central: <https://dealer.cat.com/products/wtc>.

There are a variety of work tools for small-medium wheel loaders that have couplers. It is important to check the tasks that the wheel loader will perform and equip as needed. The 924-980 wheel loaders have three waste specific designed 'pin on' buckets to choose from.

- **Load & Carry Bucket** — An overall use bucket that is open and deep throated to gather and retain large loads. This bucket provides the ability to push, stockpile, load, and tamp no matter what type of loading is required.
- **Doze Bucket** — The height of this bucket provides more of a push platform to move heavy loads on the floor into waiting haul vehicles. Its main strengths are for pushing, stockpiling, and loading below grade vehicles.
- **Tamp and Clamp Bucket** — Designed with a longer snout and "optional" top clamps, this bucket is best for sorting, loading, and tamping haul vehicles with hard to handle materials. It has slightly less capacity than the load & carry and push buckets.

There are a variety of waste work tools for excavators and wheeled excavators. For Tracked and Wheeled Excavators you need to ask its primary use. Loading and Tamping, Sorting, Combination, Other Support?

- **Trash Grapple** — Designed to load and tamp large loads of material into haul vehicles. They can perform some material separation, but its main strength would be to load and tamp.

- **Sorting Grapple** — This grapple is designed to sort, separate, and load material. Equipped with a rotator, its main strength lies in the ability to separate material quickly, swing/rotate, and load haul vehicles, conveyors, and hoppers efficiently.
- **Orange Peel Grapple** — Also designed to sort, separate, and load material, its main strength is in a slightly larger load capability than the sorting grab. It also has the capability to rotate.
- **Contractor's Grapple** — Designed like the Waste Grapple, it is slightly smaller with a two over three tine configuration instead of four over five. It is heavier in construction and designed for materials heavier than MSW.

There is a wide variety of work tools for Excavators (wheeled and tracked) that can be used in waste applications; the above are "waste handling" tools designed for the application.

### Support Work Tools

Brooms, pallet forks, bale clamps, blades, lifting arms, are just a few of the 'coupler attached' work tools that are used within the waste industry. A thorough assessment of primary and support roles of machine needs to be performed.

As stated in the chart, please contact your Dealer/Waste Representative or *Cat.com* websites for more information.





# WHEEL DOZERS SOIL COMPACTORS

## CONTENTS

### WHEEL DOZERS

Features . . . . .	22-1
Specifications . . . . .	22-2
Travel Speeds . . . . .	22-4
Rimpull . . . . .	22-4
Machine Selection . . . . .	22-6
Counterweights and Ballast . . . . .	22-6
Tire Selection & Maintenance . . . . .	22-7
Bulldozer Specifications . . . . .	22-8
Work Tools Specifications . . . . .	22-9

### SOIL COMPACTORS

Features . . . . .	22-11
Specifications . . . . .	22-12
Rimpull . . . . .	22-13
Compaction Fundamentals . . . . .	22-14
Compactor Types and Zones of Application . . . . .	22-15
Estimating Production (Example Problems) . . . . .	22-16
Production Table . . . . .	22-17
Bulldozer Specifications . . . . .	22-17
Ground Contact Pressures . . . . .	22-18

## WHEEL DOZERS

### Features:

- **Reliable Cat® power train:** four-stroke-cycle diesel with adjustment-free fuel system ... full power shift with single lever on-the-go shifting.
- **Articulated frame steering** with hinge point midway between front and rear axles ... short turning radius, long wheelbase ... rear and front wheels track at all times.
- **Machine balance** ... equal weight distribution on axles when blading.
- **All dozer functions**, including tip and tilt, hydraulically controlled from operator's seat.
- **STIC™ (Steering Transmission Integrated Control)** Steering is now offered on all Wheel Dozers, except the 814.

Throughout this document, references to Tier 4 Interim/Stage IIIB/Japan 2011 (Tier 4 Interim) include U.S. EPA Tier 4 Interim, EU Stage IIIB, and Japan 2011 (Tier 4 Interim) equivalent emission standards. References to Tier 4 Final/Stage IV/Japan 2014 (Tier 4 Final) include U.S. EPA Tier 4 Final, EU Stage IV, and Japan 2014 (Tier 4 Final) emission standards.

Throughout this document, references to Tier 1/Stage I include U.S. EPA Tier 1 and EU Stage I equivalent emission standards. References to Tier 2/Stage II/Japan 2001 (Tier 2) equivalent include U.S. EPA Tier 2, EU Stage II, and Japan 2001 (Tier 2) equivalent emission standards. References to Tier 3/Stage IIIA/Japan 2006 (Tier 3) equivalent include U.S. EPA Tier 3, EU Stage IIIA, and Japan 2006 (Tier 3) equivalent emission standards.

MODEL	814F2		824K	
Tier 4 Final/Stage IV/Japan 2014 (Tier 4 Final):			<b>Prefix 234</b>	
Flywheel Power	—			
Net	—		302 kW	<b>405 hp</b>
Max.	—		324 kW	<b>435 hp</b>
Tier 3/Stage IIIA/Japan 2006 (Tier 3) Equivalent:			<b>Prefix RWB</b>	
Flywheel Power	<b>Prefix BXG</b>			
Net	173 kW	<b>232 hp</b>	302 kW	<b>405 hp</b>
Max.	189 kW	<b>253 hp</b>	324 kW	<b>435 hp</b>
Operating Weight*	21 713 kg	<b>47,877 lb</b>	34 004 kg	<b>74,966 lb</b>
Emission Standards	<b>Tier 3/Stage IIIA/ Japan 2006 (Tier 3) Equivalent</b>		<b>Tier 4 Final/Stage IV/ Japan 2014 (Tier 4 Final) Tier 3/Stage IIIA/ Japan 2006 (Tier 3) Equivalent</b>	
Engine Model	<b>C9 ACERT™</b>		<b>C15 ACERT</b>	
Rated Engine RPM	<b>2100</b>		<b>1800</b>	
No. Cylinders	<b>6</b>		<b>6</b>	
Displacement	8.8 L	<b>537 in<sup>3</sup></b>	15.2 L	<b>928 in<sup>3</sup></b>
Speeds:				
Forward	<b>4</b>		<b>4</b>	
Reverse	<b>4</b>		<b>4</b>	
Top Speed Forward	30.9 km/h	<b>19.2 mph</b>	34.8 km/h	<b>21.6 mph</b>
Turning Radius with Blade	7.17 m	<b>23'6"</b>	6.0 m	<b>19'8"</b>
Standard Tire Size	<b>23.5R25 ★ (L-3)</b>		<b>875/65R29 ★/★★ (L-4)</b>	
Fuel Tank Refill Capacity	446 L	<b>118 U.S. gal</b>	782 L	<b>207 U.S. gal</b>
Diesel Exhaust Fluid Tank Refill Capacity [required for Tier 4 Final/Stage IV/ Japan 2014 (Tier 4 Final) machines]	—		32 L	<b>8.5 U.S. gal</b>
GENERAL DIMENSIONS:				
Height (to top of ROPS)	3.3 m	<b>10'8"</b>	4.1 m	<b>13'5"</b>
Height (stripped top)**	2.4 m	<b>7'9"</b>	3.2 m	<b>10'6"</b>
Wheel Base	3.35 m	<b>11'0"</b>	3.7 m	<b>12'2"</b>
Overall Length with Dozer Blade	6.9 m	<b>22'8"</b>	8.4 m	<b>27'8"</b>
Width (over standard tires)	2.8 m	<b>9'2"</b>	3.4 m	<b>11'2"</b>
Ground Clearance	366 mm	<b>14.4"</b>	441 mm	<b>17.4"</b>
	<b>Straight Bulldozer</b>		<b>Straight Bulldozer</b>	
Width	3.6 m	<b>11'8"</b>	4.5 m	<b>14'8"</b>
Height	1.1 m	<b>3'6"</b>	1.23 m	<b>4'0"</b>
Capacity	2.73 LCM	<b>3.6 LCY</b>	5.0 LCM	<b>6.5 LCY</b>
Ground Clearance Below Skid Shoe	748 mm	<b>2'6"</b>	1.06 m	<b>3'6"</b>
Depth of Cut	528 mm	<b>20.8"</b>	448 mm	<b>17.6"</b>
Tilt Adjustment	795 mm	<b>2'6"</b>	1.17 m	<b>3'8"</b>
Tip Adjustment	<b>15°</b>		<b>18°</b>	
Lift Speed	0.4 m/sec	<b>1.3 ft/sec</b>	0.46 m/sec	<b>1.46 ft/sec</b>

\*Operating Weight includes straight dozer, lubricants, coolant, ROPS cab, full fuel tank and operator.

\*\*Height (stripped top) — without ROPS, exhaust, seat back or easily removed encumbrances.

MODEL	834K		844K		854K	
Tier 4 Final/Stage IV/ Japan 2014 (Tier 4 Final):						
Flywheel Power	<b>Prefix TWY</b>		<b>Prefix MBE</b>		<b>Prefix KK3</b>	
Net	370 kW	<b>496 hp</b>	521 kW	<b>699 hp</b>	607 kW	<b>814 hp</b>
Max.	419 kW	<b>562 hp</b>	571 kW	<b>766 hp</b>	671 kW	<b>900 hp</b>
Tier 3/Stage IIIA/Japan 2006 (Tier 3) Equivalent:						
Flywheel Power	<b>Prefix LWY</b>		—		—	
Net	370 kW	<b>496 hp</b>	—		—	
Max.	419 kW	<b>562 hp</b>	—		—	
Tier 2/Stage II/Japan 2001 (Tier 2) Equivalent:						
Flywheel Power	<b>Prefix LWY</b>		<b>Prefix KLS</b>		<b>Prefix RM3</b>	
Net	370 kW	<b>496 hp</b>	521 kW	<b>699 hp</b>	607 kW	<b>814 hp</b>
Max.	419 kW	<b>562 hp</b>	571 kW	<b>766 hp</b>	676 kW	<b>907 hp</b>
Operating Weight*	47 750 kg	<b>105,271 lb</b>	74 883 kg	<b>165,089 lb</b>	98 100 kg	<b>216,273 lb</b>
Emission Standards	<b>Tier 4 Final/Stage IV/ Japan 2014 (Tier 4 Final)<sup>1</sup></b>		<b>Tier 4 Final/Stage IV/ Japan 2014 (Tier 4 Final)<sup>2</sup></b>		<b>Tier 4 Final/Stage IV/ Japan 2014 (Tier 4 Final)<sup>2</sup></b>	
Engine Model	<b>C18 ACERT</b>		<b>C27 ACERT</b>		<b>C32 ACERT</b>	
Rated Engine RPM	<b>1800</b>		<b>1800</b>		<b>1750</b>	
No. Cylinders	<b>6</b>		<b>12</b>		<b>12</b>	
Displacement	18.1 L	<b>1105 in<sup>3</sup></b>	27.0 L	<b>1650 in<sup>3</sup></b>	32.1 L	<b>1959 in<sup>3</sup></b>
Speeds:						
Forward	<b>4</b>		<b>3</b>		<b>3</b>	
Reverse	<b>3</b>		<b>3</b>		<b>3</b>	
Top Speed Forward	35.4 km/h	<b>22 mph</b>	21 km/h	<b>13 mph</b>	21.2 km/h	<b>13.2 mph</b>
Turning Radius with Blade	8.5 m	<b>28'0"</b>	10.4 m	<b>34'0"</b>	11.7 m	<b>38'5"</b>
Standard Tire Size	<b>35/65R33 ★★ (L-4)</b>		<b>45/65R39 ★ (L-5)</b>		<b>45/65R45 ★★ (L-4)</b>	
Fuel Tank Refill Capacity	793 L	<b>209 U.S. gal</b>	1016 L	<b>268 U.S. gal</b>	1562 L	<b>413 U.S. gal</b>
Diesel Exhaust Fluid Tank Refill Capacity	32 L	<b>8.5 U.S. gal</b>	—		—	
GENERAL DIMENSIONS:						
Height (to top of ROPS)	4.18 m	<b>13'7"</b>	5.24 m	<b>17'2"</b>	5.59 m	<b>18'3"</b>
Height (stripped top)**	3.15 m	<b>10'4"</b>	3.8 m	<b>12'6"</b>	5.23 m	<b>17'2"</b>
Wheel Base	4.55 m	<b>14'11"</b>	4.6 m	<b>15'1"</b>	5.89 m	<b>19'3"</b>
Overall Length with Dozer Blade	10.42 m	<b>34'2"</b>	11.12 m	<b>36'6"</b>	13.41 m	<b>44'0"</b>
Width (over standard tires)	3.47 m	<b>11'5"</b>	4.37 m	<b>14'4"</b>	4.58 m	<b>15'0"</b>
Ground Clearance	531 mm	<b>21"</b>	431 mm	<b>1'5"</b>	691 mm	<b>27"</b>
	<b>Straight Bulldozer</b>		<b>Semi-U Dozer</b>		<b>Semi-U Dozer</b>	
Width	5.07 m	<b>16'8"</b>	5.28 m	<b>17'4"</b>	6.32 m	<b>20'8"</b>
Height	1.54 m	<b>5'0"</b>	1.88 m	<b>6'2"</b>	5.59 m	<b>18'3"</b>
Capacity	7.87 LCM***	<b>10.3 LCY***</b>	16.1 m <sup>3</sup>	<b>21.1 yd<sup>3</sup></b>	25.4 m <sup>3</sup>	<b>33.1 yd<sup>3</sup></b>
Ground Clearance Below						
Skid Shoe	1324 mm	<b>4'4"</b>	1372 mm	<b>4'6"</b>	691 mm	<b>27"</b>
Depth of Cut	557 mm	<b>21.9"</b>	466 mm	<b>18"</b>	398 mm	<b>1'3"</b>
Tilt Adjustment	1.27 m	<b>4'2"</b>	830 mm	<b>2'9"</b>	1165 mm	<b>3'8"</b>
Tip Adjustment	<b>21°</b>		<b>13°</b>		<b>15°</b>	
Lift Speed	0.81 m/sec	<b>2.66 ft/sec</b>	0.353 m/sec	<b>1.2 ft/sec</b>	0.310 m/sec	<b>1.05 ft/sec</b>

\*Operating Weight of 844K and 854K includes Semi-U, coolant, ROPS cab, full fuel tank and operator.

Operating Weight of 834K includes straight dozer, lubricants, coolant, ROPS cab, full fuel tank and operator.

\*\*Height (stripped top) — without ROPS, exhaust, seat back or easily removed encumbrances.

\*\*\*Capacity of 834K U-Blade is 11.1 LCM (**14.5 LCY**).

<sup>1</sup>Products available to meet Tier 2/Stage II/Japan 2001 (Tier 2) equivalent, Tier 3/Stage IIIA/Japan 2006 (Tier 3) equivalent, or Tier 4 Final/Stage IV/Japan 2014 (Tier 4 Final) emission standards.

<sup>2</sup>Products available to meet Tier 2/Stage II/Japan 2001 (Tier 2) equivalent, or Tier 4 Final/Stage IV/Japan 2014 (Tier 4 Final) emission standards.

MODEL	814F2		824K		834K*		844K*		854K*	
FORWARD GEAR	km/h	mph	km/h	mph	km/h	mph	km/h	mph	km/h	mph
1	5.7	3.6	6.2	3.9	6.8	4.2	7.0	4.4	6.8	4.2
2	10.2	6.4	11.1	6.9	11.6	7.2	12.2	7.6	12.1	7.5
3	17.9	11.2	19.6	12.2	20.3	12.6	21.0	13.0	20.9	13.0
4	31.0	19.3	34.8	21.6	35.4	22.0	—	—	—	—
REVERSE GEAR										
1	6.5	4.1	7.1	4.4	6.8	4.2	7.7	4.6	7.5	4.7
2	11.6	7.3	12.6	7.8	12.2	7.6	13.4	8.4	13.3	8.3
3	20.4	12.7	22.4	13.9	21.4	13.3	23.0	14.3	23.0	14.3
4	34.9	21.8	39.7	24.7	—	—	—	—	—	—

\*2% rolling resistance.

814F2

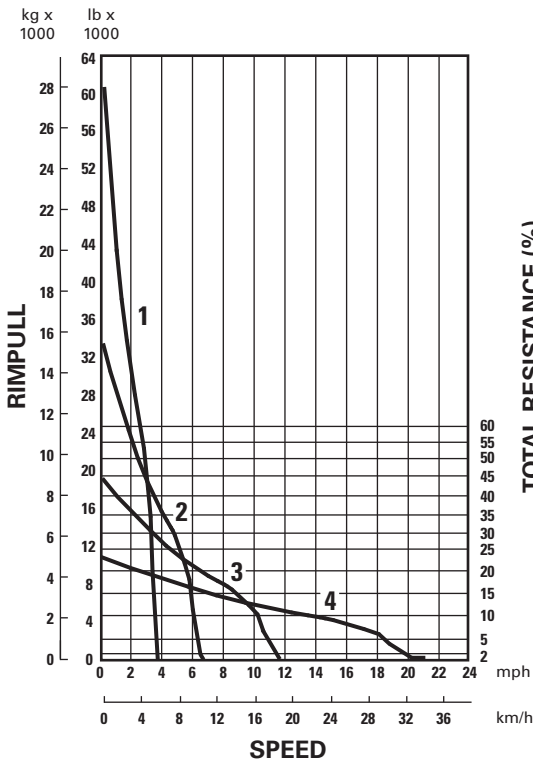

824K

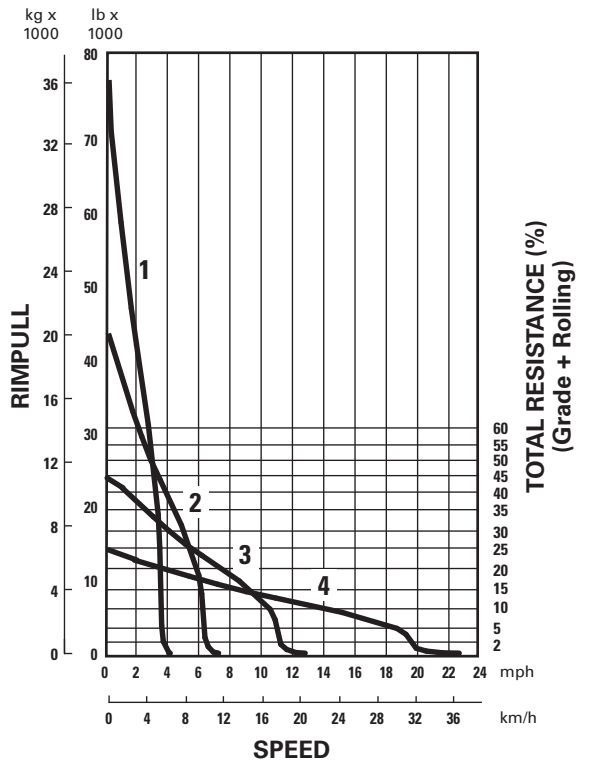

KEY  
 1 - 1st Gear  
 2 - 2nd Gear  
 3 - 3rd Gear  
 4 - 4th Gear

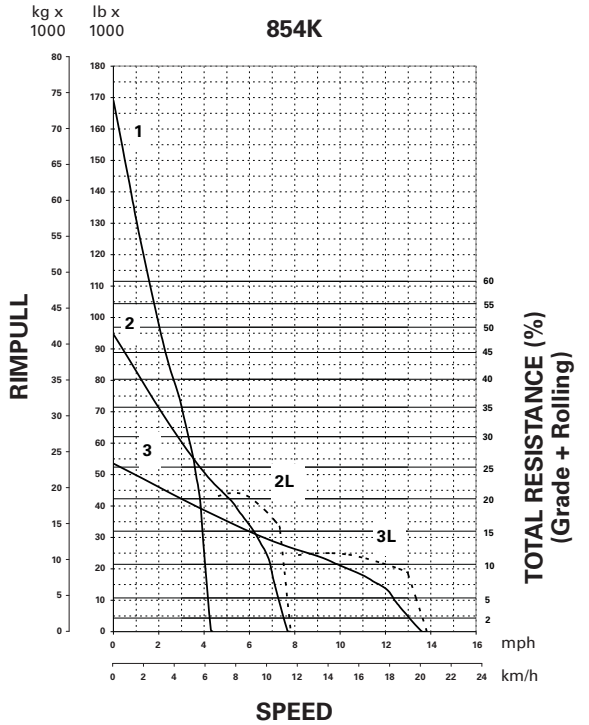
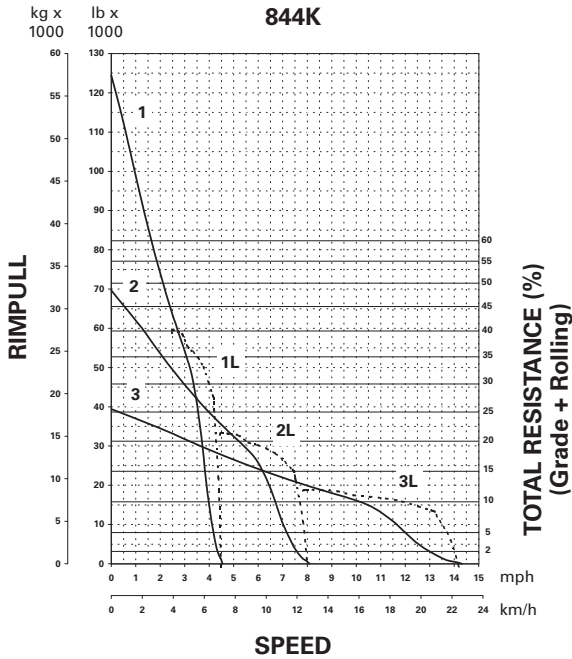
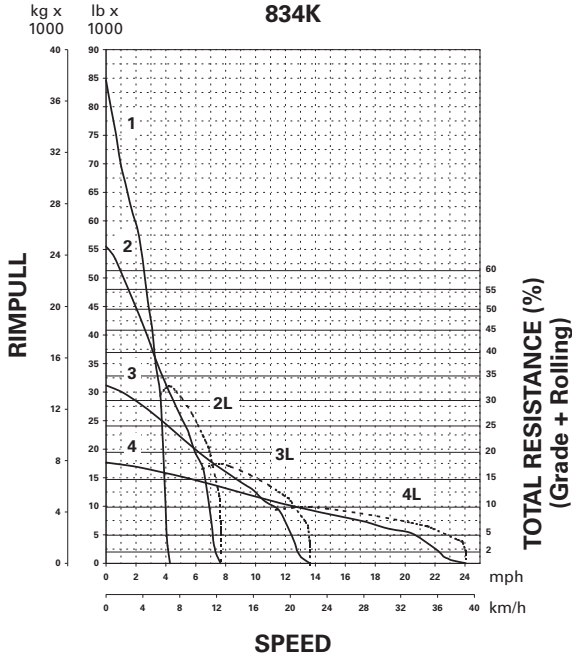

**CONSIDERATIONS IN MACHINE SELECTION**

The following factors should be considered when comparing wheels vs. tracks:

**Traction**

You can figure coefficient of traction, depending on underfoot conditions, from the Table Section in this book.

Wheels — up to 0.65 (in quarry pit with good floor)

Track — up to 0.90 (in soils permitting grouser penetration)

Usable Rimpull = Machine Weight × Coefficient of Traction

**Speed**

Wheels — travel speeds up to three times higher than track.

**Maneuverability**

Articulated steering and good visibility give wheel tractors high maneuverability.

**Cost**

See Owning and Operating Costs section. Tire vs. undercarriage costs can often be the deciding factor in selecting wheels or tracks.

**Compaction**

Ground Pressure:

Wheels — from 241 kPa (35 psi) to 310 kPa (45 psi)

Tracks — from 82 kPa (12 psi) to 97 kPa (14 psi)

**Application**

*Utility* ... mobility, maneuverability and good speed suit wheel tractors for yard and stockpile work and for clean-up around shovels. Lower maintenance costs may be realized in certain soils that can be highly abrasive to track-type undercarriages.

*Coal pile* ... recommend wheel tractors in this application when following conditions are present:

- Long push distances
- Need for good material spread
- High degree of compaction desired

*Production Dozing* ... a wheel tractor should be considered in the following conditions:

- Long push distances
- Loose soils, little or no rock
- Level or downhill work
- Good underfoot conditions

*Pushloading Scrapers* ... a wheel tractor should be considered in the following conditions:

- Thin scraper cut
- Good underfoot conditions — no rock
- Higher push speeds

*Chip and Coal Scoops* ... a wheel dozer scoop should be considered in the following conditions:

- Long push distances
- Light, well processed materials such as coal or wood chips
- High degree of compaction desired
- Low to modest grades

**COUNTERWEIGHTS AND BALLAST**

For each specific application, there is a correct machine weight for proper balancing of traction, flotation, mobility and response.

- Low machine weight may increase tire slipping and wear, but improves flotation, mobility and machine response.
- High machine weight increases traction, but decreases mobility and response.

The machine weight is optimum for the operating conditions when wheel slipping barely occurs in the gear being used. Weight distribution under operating conditions should then be approximately equal between the wheels to balance power to each axle.

**Application**

Lower machine weight is usually required for applications such as fill spreading, stockpiling, road maintenance, towing compactors, and shovel cleanup. These are generally performed in either first or second gear. However, usage of second gear may involve a tradeoff of increased GET wear on the blade.

Higher machine weight is usually required for applications such as heavy dozing and push-loading, which are generally performed in first gear.

## TIRE SELECTION & MAINTENANCE

Requirements of traction, flotation and tire life are met by a choice of tire size, tread design and inflation pressure.

### Tire Width

For good conditions with little rolling resistance on surfaces where flotation is no problem, a narrower tire may be most economical. It may also be considered in muddy conditions in which the mud can be penetrated to reach firm earth underneath.

Where flotation problems and increased rolling resistance are encountered, wider tires are recommended. The greater contact area and shallower penetration increases flotation.

### Tire Size

Larger optional tires will also improve flotation in soft conditions. With larger diameter, rimpull will be reduced which may be desirable to help control wheel spin.

**Rock — Deep Tread (L-4)** provides 50% more tread depth, thicker undertread and sidewall with increased tire life when compared to the L-3 tire. Recommended in rock conditions where sharp fragments cause high tire wear or sudden failures.

**Rock — Extra Deep Tread (L-5)** provides 150% more tread depth when compared to the L-3 tire. Intended for severe rock conditions with extreme penetration hazards.

### Inflation Pressure

In average operating conditions the recommended inflation pressure prevents excessive deflection and minimizes tire rollover on side slopes.

### Over-inflation

Reduces amount of tread contact with ground and provides less flotation. Over-inflation causes center of tread to wear faster and increases the chance of cuts and impact breaks.

### Under-inflation

Can cause permanent tire damage in the form of flex breaks, radial cracks, and tread or ply separation. On jobs where wrinkling and bead rollover *are not* apparent, inflation pressure may be reduced to a minimum of:

<i>Bias Ply</i>	—	170 kPa (25 psi) on 35/65-33
		170 kPa (25 psi) on 29.5-25
		170 kPa (25 psi) on 26.5-25
		170 kPa (25 psi) on 23.5-25
<i>Radial</i>	—	310 kPa (45 psi) on 35/65-R33
		310 kPa (45 psi) on 29.5-R25
		205 kPa (30 psi) on 26.5-R25
		240 kPa (35 psi) on 23.5-R25

Reduced pressure will:

- Increase flotation and traction in sand.
- Improve envelopment characteristics to reduce sudden death failure on rock jobs.
- Provide better tread wear by reducing contact pressure between tire and ground.

Consult your tire manufacturer before changing tire pressures.



MODEL	814F2		824K		824K	
Type	Straight		Straight		SU-Blade	
Capacity**	2.66 m <sup>3</sup>	3.5 yd <sup>3</sup>	5.0 m <sup>3</sup>	6.6 yd <sup>3</sup>	7.68 m <sup>3</sup>	10.0 yd <sup>3</sup>
Weight, Dozer*	3740 kg	8245 lb	5136 kg	11,323 lb	—	
General Dimensions (Tractor & Dozer)						
Length	6.9 m	22'6"	8.4 m	27'7"	8.7 m	28'7"
Width	3.6 m	11'8"	4.51 m	14'10"	4.42 m	14'6"
Blade:						
Width (including std. end bits)	3.6 m	11'8"	4.51 m	14'10"	4.42 m	14'6"
Height	1110 mm	3'8"	1230 mm	4'0"	1551 mm	5'1"
Max. Digging Depth	528 mm	20.8"	448 mm	1'6"	477 mm	1'7"
Ground Clearance @ Full Lift Under Skid Plate	718 mm	2'4"	1057 mm	3'6"	1068 mm	3'6"
Tilt Adjust. from Horizontal	795 mm	2'6"	1167 mm	3'10"	1120 mm	3'8"
Total Tip Adjustment	15°		18°		—	

MODEL	824K		824K		834K	
Type	U-Blade		Extreme Service U-Blade		Straight	
Capacity**	7.65 m <sup>3</sup>	10.0 yd <sup>3</sup>	8.13 m <sup>3</sup>	10.6 yd <sup>3</sup>	7.9 m <sup>3</sup>	10.33 yd <sup>3</sup>
Weight, Dozer*	—		—		47 206 kg	104,069 lb
General Dimensions (Tractor & Dozer)						
Length	8.92 m	29'3"	8.92 m	29'3"	9.93 m	32'7"
Width	4.35 m	14'3"	4.35 m	14'3"	5.07 m	16'7"
Blade:						
Width (including std. end bits)	4.35 m	14'3"	4.35 m	14'3"	5.07 m	16'7"
Height	1350 mm	4'5"	1350 mm	4'5"	1537 mm	5'0"
Max. Digging Depth	461 mm	1'6"	461 mm	1'6"	557 mm	21.9"
Ground Clearance @ Full Lift Under Skid Plate	1051 mm	3'5"	1051 mm	3'5"	1324 mm	4'4"
Tilt Adjust. from Horizontal	1132 mm	3'9"	1132 mm	3'9"	1270 mm	4'2"
Total Tip Adjustment	—		—		20.5°	

MODEL	834K		834K		844K		854K	
Type	U-Blade		SU-Blade		Semi-U		Semi-U	
Capacity**	11.13 m <sup>3</sup>	14.56 yd <sup>3</sup>	10.13 m <sup>3</sup>	13.25 yd <sup>3</sup>	15.9 m <sup>3</sup>	20.7 yd <sup>3</sup>	25.4 m <sup>3</sup>	33.1 yd <sup>3</sup>
Weight, Dozer*	48 564 kg	107,064 lb	8052 kg	17,751 lb	15 670 kg	34,520 lb	21 910 kg	48,270 lb
General Dimensions (Tractor & Dozer)								
Length	10.47 m	34'4"	10.47 m	34'4"	10.94 m	35'9"	13.405 m	44'0"
Width	5.15 m	16'11"	4.69 m	15'5"	5.42 m	17'8"	6.321 m	20'7"
Blade:								
Width (including std. end bits)	5.15 m	16'11"	4.69 m	15'5"	5.42 m	17'8"	6.321 m	20'7"
Height	1537 mm	5'0"	1855 mm	6'1"	1834 mm	5'9"	2179 mm	7'1"
Max. Digging Depth	527 mm	20.7"	507 mm	20.0"	466 mm	18.3"	398 mm	15.7"
Ground Clearance @ Full Lift Under Skid Plate	1338 mm	4'4"	1352 mm	4'5"	1372 mm	4'6"	1540 mm	5'0.4"
Tilt Adjust. from Horizontal	1270 mm	4'2"	1270 mm	4'2"	830 mm	2'8.7"	1165 mm	3'8"
Total Tip Adjustment	22°		22°		13°		15°	

\*Total Bulldozer Arrangement.

\*\*Blade capacities determined by SAE J1265.

<b>COAL U-BLADE</b>	<b>814F2</b>		<b>824H</b>		<b>834K</b>	
<b>Model:</b> Replaces "S" Blade	Coal U-Blade		Coal U-Blade		Coal U-Blade	
<b>Blade:</b>						
Capacity	11 m <sup>3</sup>	14 yd <sup>3</sup>	16.2 m <sup>3</sup>	21 yd <sup>3</sup>	22.2 m <sup>3</sup>	29 yd <sup>3</sup>
Length (Cutting Width)	4318 mm	14'2"	4798 mm	15'8"	5680 mm	18'7"
Height, wing section (tapered down)	1473 mm	4'10"	1745 mm	5'7"	1960 mm	6'5"
Wing Angle	25°		30°		30°	
Weight, Installed (Without Hydraulics)	1950 kg	4300 lb	3193 kg	7040 lb	5020 kg	11,300 lb

	<b>844K</b>		<b>854K</b>	
<b>Model:</b> Replaces "S" Blade	Coal U-Blade		Coal U-Blade	
<b>Blade:</b>				
Capacity	30.7 m <sup>3</sup>	40.2 yd <sup>3</sup>	44.7 m <sup>3</sup>	58.2 yd <sup>3</sup>
Length (Cutting Width)	5846 mm	19'2"	7200 mm	23'7"
Height, wing section (tapered down)	2024 mm	6'8"	2500 mm	8'2"
Wing Angle	30°		30°	
Weight, Installed (Without Hydraulics)	6237 kg	13,830 lb	10 333 kg	22,780 lb

<b>WOODCHIP U-BLADE</b>	<b>824H</b>		<b>834K</b>	
<b>Model:</b> Replaces "S" Blade	Woodchip U-Blade		Woodchip U-Blade	
<b>Blade:</b>				
Capacity	24 m <sup>3</sup>	31 yd <sup>3</sup>	30.1 m <sup>3</sup>	40 yd <sup>3</sup>
Length (Cutting Width)	4775 mm	15'8"	5700 mm	18'8"
Height, wing section	2261 mm	7'5"	2350 mm	7'8"
Wing Angle	30°		30°	
Weight	3515 kg	7750 lb	5155 kg	11,600 lb

<b>COAL SCOOP WITH TILT</b>	<b>814F2</b>		<b>824H</b>		<b>834K</b>	
<b>Model:</b> <b>Scoop:</b>	Coal Scoop with Tilt		Coal Scoop with Tilt		Coal Scoop with Tilt	
Lift and Carrying Capacity	11.5 m <sup>3</sup>	15 yd <sup>3</sup>	13.4 m <sup>3</sup>	17.5 yd <sup>3</sup>	22.9 m <sup>3</sup>	30 yd <sup>3</sup>
Dozing Capacity	19.1 m <sup>3</sup>	25 yd <sup>3</sup>	26.8 m <sup>3</sup>	35 yd <sup>3</sup>	44.2 m <sup>3</sup>	58 yd <sup>3</sup>
Width	3734 mm	12'3"	4058 mm	13'4"	4851 mm	15'11"
Height	1626 mm	5'4"	1839 mm	6'1"	2339 mm	7'8"
Weight	5216 kg	11,500 lb	6763 kg	14,913 lb	9711 kg	21,409 lb

<b>CHIP SCOOP WITH TILT</b>	<b>814F2</b>		<b>824H</b>		<b>834K</b>	
<b>Model:</b> <b>Scoop:</b>	Chip Scoop with Tilt		Chip Scoop with Tilt		Chip Scoop with Tilt	
Lift and Carrying Capacity	15.3 m <sup>3</sup>	20 yd <sup>3</sup>	20.6 m <sup>3</sup>	27 yd <sup>3</sup>	26.7 m <sup>3</sup>	35 yd <sup>3</sup>
Dozing Capacity	30.6 m <sup>3</sup>	40 yd <sup>3</sup>	41.3 m <sup>3</sup>	54 yd <sup>3</sup>	53.5 m <sup>3</sup>	70 yd <sup>3</sup>
Width	3734 mm	12'3"	4039 mm	13'3"	4851 mm	15'11"
Height	2286 mm	7'6"	2489 mm	8'2"	2649 mm	8'8"
Weight	5390 kg	11,880 lb	11 420 kg	19,125 lb	9804 kg	21,614 lb



# SOIL COMPACTORS

## CONTENTS

Features . . . . .	22-11
Specifications . . . . .	22-12
Rimpull . . . . .	22-13
Compaction Fundamentals . . . . .	22-14
Compactor Types and Zones of Application . . . . .	22-15
Estimating Production (Example Problems) . . . . .	22-16
Production Table . . . . .	22-17
Bulldozer Specifications . . . . .	22-17
Ground Contact Pressures . . . . .	22-18

## Features:

- **Dozing, filling and compacting versatility.**
- **High speed operation** with responsive Cat diesel engine, single-lever planetary power shift transmission, and all-wheel drive.
- **Articulated frame** makes maneuvering quick and easy. Long wheel base for stability.
- **Wheels with tamping foot design and chevron pattern** give traction, penetration and compaction needed for high production. Foot pattern reversed on trailing drums to prevent overprinting lead drums.
- **Rear drums track front** for double compactive effort. Drum spacing covers mid-axle strip on return pass.
- **Rear axle oscillation** keeps all drums on ground for traction and stability.
- **Cleaner bars** keep drums free of carry over earth regardless of rolling direction. Adjustable, replaceable.
- **Optional fill spreading dozer** has single lever control for raise, lower, hold and float. (Blade tilt optional.)
- The 825K now offers **STIC (Steering Transmission Integrated Control) Steering** as a standard feature.

MODEL	815K		825K	
Tier 4 Final/Stage IV/Japan 2014 (Tier 4 Final):				
Flywheel Power	<b>Prefix MBB</b>		<b>Prefix 233</b>	
Net	185 kW	<b>248 hp</b>	302 kW	<b>405 hp</b>
Max.	212 kW	<b>284 hp</b>	324 kW	<b>435 hp</b>
Tier 3/Stage IIIA/Japan 2006 (Tier 3) Equivalent:				
Flywheel Power	<b>Prefix WCS</b>		<b>Prefix SEE</b>	
Net	186 kW	<b>249 hp</b>	302 kW	<b>405 hp</b>
Max.	213 kW	<b>286 hp</b>	324 kW	<b>435 hp</b>
Operating Weight*	22 386 kg	<b>49,353 lb</b>	35 528 kg	<b>78,326 lb</b>
Emission Standards	<b>Tier 4 Final/Stage IV/ Japan 2014 (Tier 4 Final) Tier 3/Stage IIIA/ Japan 2006 (Tier 3) Equivalent</b>		<b>Tier 4 Final/Stage IV/ Japan 2014 (Tier 4 Final) Tier 3/Stage IIIA/ Japan 2006 (Tier 3) Equivalent</b>	
Engine Model	<b>C7.1 ACERT</b>		<b>C15 ACERT</b>	
Rated Engine RPM	<b>2200</b>		<b>1800</b>	
No. Cylinders	<b>6</b>		<b>6</b>	
Displacement	7.01 L	<b>428 in<sup>3</sup></b>	15.2 L	<b>928 in<sup>3</sup></b>
Speeds:				
Forward	<b>3</b>		<b>3</b>	
Reverse	<b>3</b>		<b>3</b>	
Turning Radius — outside Corner of Blade	6.44 m	<b>21'2"</b>	7.3 m	<b>23'9"</b>
Fuel Tank Refill Capacity	500 L	<b>132 U.S. gal</b>	782 L	<b>206.6 U.S. gal</b>
Diesel Exhaust Fluid Tank Refill Capacity [required for Tier 4 Final/Stage IV/ Japan 2014 (Tier 4 Final) machines]	16 L	<b>4.2 U.S. gal</b>	32 L	<b>8.5 U.S. gal</b>
TAMPING FOOT WHEELS:				
Each Drum Width	991 mm	<b>3'3"</b>	1125 mm	<b>3'8"</b>
Diameters, over Feet	1.41 m	<b>4'8"</b>	1.68 m	<b>5'5"</b>
over Drum	1.03 m	<b>3'5"</b>	1.29 m	<b>4'3"</b>
Feet per Wheel	<b>60</b>		<b>65</b>	
Feet per Row	<b>12</b>		<b>13</b>	
Rows of Feet	<b>5</b>		<b>5</b>	
Foot Length	191 mm	<b>7.5"</b>	188 mm	<b>7.4"</b>
End Area per Foot	134 cm <sup>2</sup>	<b>20.8 in<sup>2</sup></b>	192 cm <sup>2</sup>	<b>29.75 in<sup>2</sup></b>
Width of Two Pass Coverage	4.2 m	<b>13'9"</b>	5.3 m	<b>17'4"</b>
GENERAL DIMENSIONS:				
Height (to top of ROPS)	3.65 m	<b>12'0"</b>	4.05 m	<b>13'4"</b>
Height (stripped top)**	2.57 m	<b>8'5"</b>	3.2 m	<b>10'5"</b>
Wheel Base	3.35 m	<b>11'0"</b>	3.7 m	<b>12'2"</b>
Overall Length with Dozer Blade	7.19 m	<b>23'7"</b>	8.56 m	<b>28'1"</b>
Width over Drums	3.24 m	<b>10'8"</b>	3.65 m	<b>12'0"</b>
Ground Clearance	365 mm	<b>1'2"</b>	492 mm	<b>19.4"</b>
STRAIGHT BULLDOZER:				
Width over End Bits	3.76 m	<b>12'4"</b>	4.62 m	<b>15'1"</b>
Height with Cutting Edge	860 mm	<b>2'10"</b>	1030 mm	<b>3'4"</b>

\*Operating Weight includes coolant, lubricants, bulldozer, hydraulics, ROPS canopy, full fuel tank and operator.

\*\*Height (stripped top) — without ROPS, exhaust, seat back or other easily removed encumbrances.

815F2

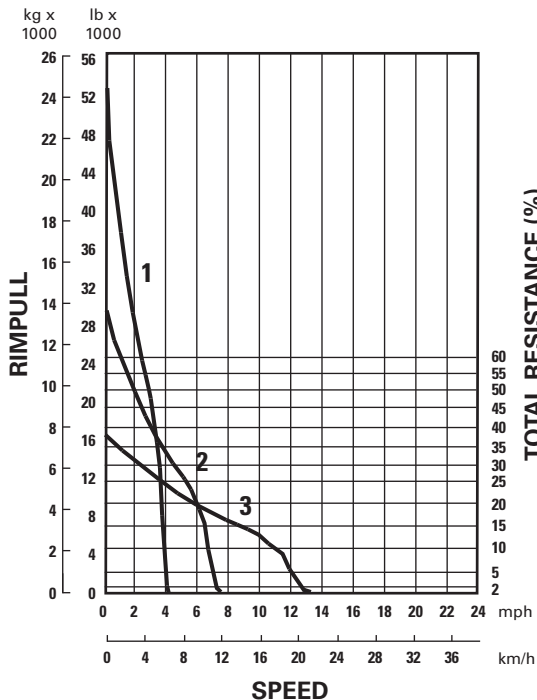

825K

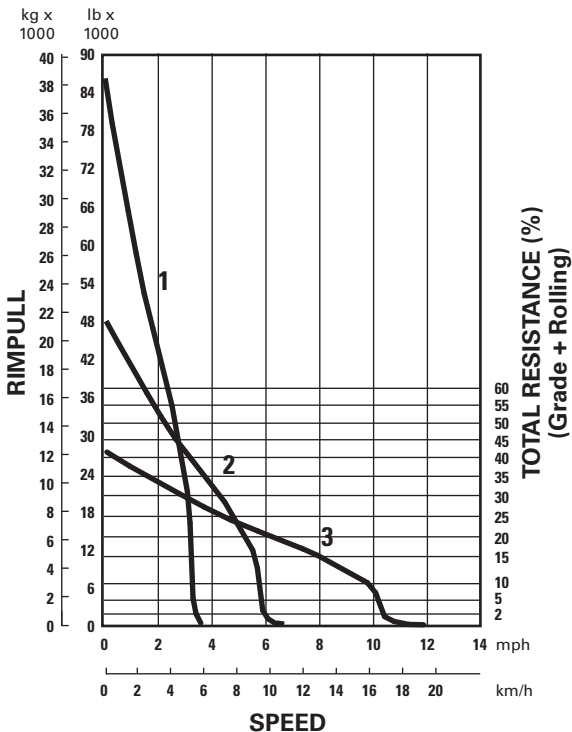

KEY  
1 - 1st Gear  
2 - 2nd Gear  
3 - 3rd Gear

**COMPACTION FUNDAMENTALS**

The following discussion applies to soil compaction only.

**Definition**

Compaction is the process of physically densifying or packing the soil ... resulting in increased weight per unit volume. It is generally accepted that the strength of a soil can be increased by densification. Three important factors affect compaction.

- Material gradation
- Moisture content
- Compactive effort

*Material Gradation* — refers to the distribution (% by weight) of the different particle sizes within a given soil sample. A sample is *well-graded* if it contains a good, even distribution of particle sizes. A sample composed of predominantly one size particle, is said to be *poorly-graded*. In terms of compaction, a well-graded soil will compact more easily than one that is poorly-graded. In well-graded material the smaller particles tend to fill the empty spaces between the larger particles, leaving fewer voids after compaction.

**MATERIAL GRADATION**

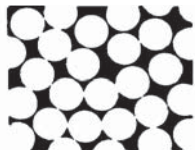

Poorly-graded

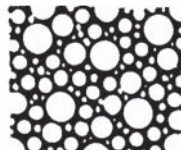

Well-graded

*Moisture Content* — or the amount of water present in a soil, is very important to compaction. Water lubricates soil particles thus helping them slide into the most dense position. Water also creates clay particle bonding, giving cohesive materials their sticky qualities.

**OPTIMUM MOISTURE**

Heavy clay	17.5%
Silty clay	15.0%
Sandy clay	13.0%
Sand	10.0%
Gravel, sand, clay mix (pit run)	7.0%

Experience has shown that it is very difficult, if not impossible, to achieve proper compaction in materials that are too dry or too wet. Soil experts have determined that in practically every soil there is an amount of water, called optimum moisture content, at which it is possible to obtain maximum density with a given amount of compactive effort. The curve below shows this relationship between dry density and moisture content. It is called a compaction curve, moisture-density curve or Proctor curve.

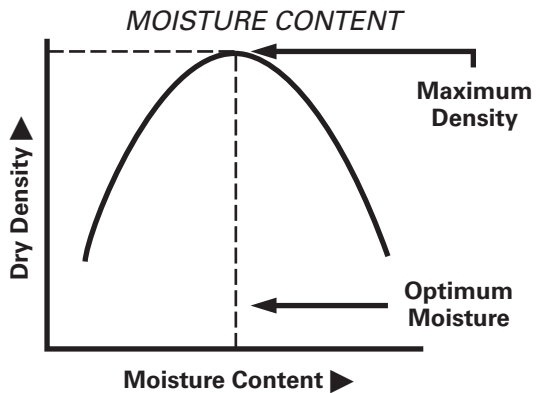

*Compactive Effort* — refers to the method employed by a compactor to impart energy into the soil to achieve compaction. Compactors are designed to use one or a combination of the following types of compactive effort.

- Static weight (or pressure)
- Kneading action (or manipulation)
- Impact (or sharp blow)
- Vibration (or shaking)

## COMPACTOR TYPES

Compaction equipment can be grouped generally into the following classifications:

- sheepsfoot
- vibratory
- pneumatic
- high speed tamping foot
- chopper wheels (see Landfill Compactor section)

Combinations of these types are also available, such as a vibrating smooth steel drum.

For ease of comparison, the compactors have been placed on the Zones of Application Chart shown below. This chart contains a range of material moistures from 100% clay to 100% sand, plus a rock zone. Each type has been positioned in what is considered to be its most effective and economical zone of application. However, it is not uncommon to find them working out of their zones. Exact positioning of the zones can vary with differing material conditions.

### RANGES OF SOIL TYPES FOR SOIL COMPACTION EQUIPMENT

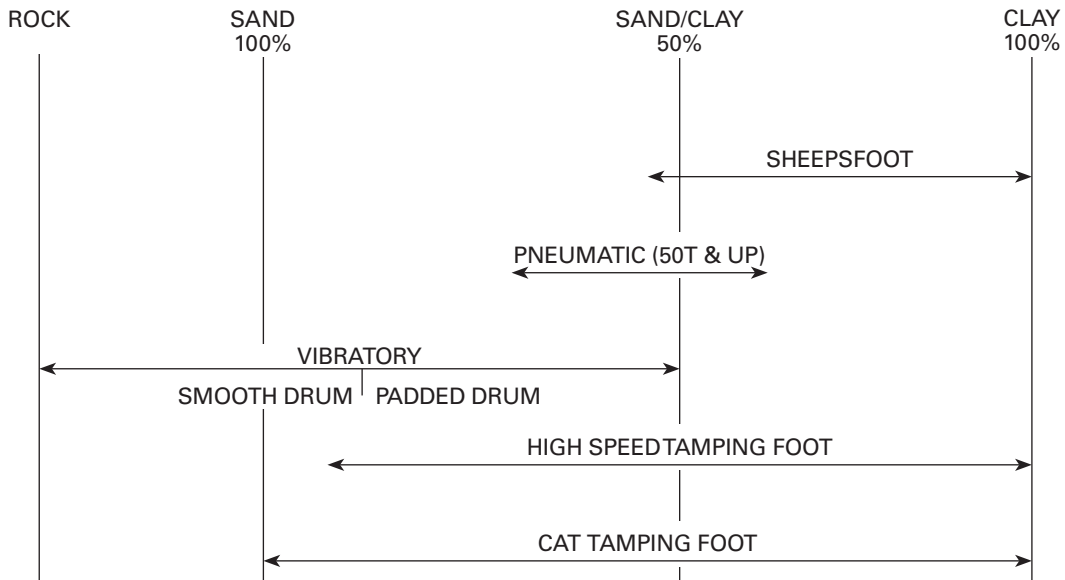



**COMPACTOR PRODUCTION**

Compactor production is expressed in compacted cubic meters (Cm<sup>3</sup>) or compacted cubic yards (CCY) per hour. Material in its natural or bank state is measured in bank cubic meters or yards (Bm<sup>3</sup> or BCY). When it is removed or placed in a fill, it is measured in loose cubic meters or yards (Lm<sup>3</sup> or LCY).

When the loose material is worked into a compacted state, the relationship of *compacted material to bank material* is shown as the shrinkage factor (SF).

$$SF = \frac{\text{Compacted cubic meters (Cm}^3\text{)}}{\text{Bank cubic meters (Bm}^3\text{)}}$$

$$SF = \frac{\text{Compacted cubic yards (CCY)}}{\text{Bank cubic yards (BCY)}}$$

The construction industry has developed the following formula for use in estimating compactor production. This formula gives the material volume a given machine can compact in a 60-minute hour.

**Metric Method**

$$\text{Cm}^3 = \frac{W \times S \times L}{P}$$

W = Compacted width per pass, in meters. (For Cat Compactors it is recommended that W = Twice the width of one wheel.)

S = Average speed, in kilometers per hour.

L = Compacted thickness of lift, in millimeters.

P = Number of machine passes to achieve compaction (**can only be determined by testing the compacted material density on-the-job**).

**English Method**

$$\text{CCY/hr} = \frac{W \times S \times L \times 16.3}{P}$$

W = Compacted width per pass, in feet. (For Cat Compactors it is recommended that W = Twice the width of one wheel.)

S = Average speed, in miles per hour.

L = Compacted thickness of lift, in inches.

16.3 = Conversion constant, equals 5280 feet ÷ 12 inches ÷ 27 cubic feet

P = Number of machine passes to achieve compaction (**can only be determined by testing the compacted material density on-the-job**).

Example problem (Metric)

Determine production for an 815F2 operating under the following conditions:

$$P = 5, S = 10 \text{ km/h}, L = 100 \text{ mm}$$

Refer to 815F2 in the production table on the next page. Read down the first column until reaching section for 5 passes. Within this section in the second column, find the speed closest to 10 km/h. Read across this line to the 100 mm compacted lift. Read the production figure given.

**Answer:** 377 Cm<sup>3</sup>/h. (Since the machine's speed of 10 km/h is slightly faster than the 9.5 of the table, production may be interpolated slightly higher — say 395 Cm<sup>3</sup>/h.)

Example problem (English)

Determine production for an 825K operating under the following conditions:

$$P = 4, S = 8 \text{ mph}, L = 6 \text{ inches}$$

Refer to the production estimating table on the next page. This table contains estimates for the 815F2 and 825K Compactors using various speeds, lift thicknesses and number of passes. These figures were calculated using the formula discussed on this page. The figures represent 100% efficiency. W = Twice the width of one wheel.

In the 825K portion of this table, read down the first column until reaching the section for four passes. Within this section in the second column, find the line for 8 mph. Read across this line to the lift thickness column for 6 inches. Read the production figure given.

**Answer:** 1444 CCY/hr.



**PRODUCTION TABLE**

MODEL AND MACHINE PASSES*	AVERAGE SPEED		COMPACTED LIFT THICKNESS								
			100 mm	4 in	150 mm	6 in	200 mm	8 in	250 mm	10 in	
	km/h	mph	m <sup>3</sup> /h	yd <sup>3</sup> /hr	m <sup>3</sup> /h	yd <sup>3</sup> /hr	m <sup>3</sup> /h	yd <sup>3</sup> /hr	m <sup>3</sup> /h	yd <sup>3</sup> /hr	
<b>815K</b>	3	6.5	4	419	548	628	822	837	1095	—	
		9.5	6	628	822	942	1232	1256	1643	—	
		13.0	8	837	1095	1256	1643	1675	2191	—	
	4	6.5	4	314	411	471	616	628	822	—	
		9.5	6	471	616	706	924	942	1232	—	
		13.0	8	628	822	942	1232	1256	1643	—	
	5	6.5	4	251	329	377	493	502	657	—	
		9.5	6	377	493	565	739	754	986	—	
		13.0	8	502	657	754	986	1005	1314	—	
	6	6.5	4	286	274	314	411	419	548	—	
		9.5	6	314	411	471	616	628	822	—	
		13.0	8	419	548	628	822	837	1095	—	
<b>825K</b>	3	6.5	4	488	642	731	962	975	1283	1219	1604
		9.5	6	713	962	1069	1444	1425	1925	1781	2406
		13.0	8	975	1283	1463	1925	1950	2566	2438	3208
	4	6.5	4	366	481	534	722	731	962	914	1203
		9.5	6	534	722	802	1083	1069	1444	1336	1804
		13.0	8	731	962	1097	1444	1463	1925	1828	2406
	5	6.5	4	293	385	439	577	585	770	731	962
		9.5	6	428	577	641	866	855	1155	1069	1444
		13.0	8	585	770	878	1155	1170	1540	1463	1925
	6	6.5	4	244	321	366	481	488	642	609	802
		9.5	6	356	481	534	722	713	962	891	1203
		13.0	8	488	642	731	962	975	1283	1219	1604

\*The number of machine passes required is dependent on soil type, moisture content, desired compaction and machine weight.

MODEL	815K		825K	
Type	Fill Spreading		Fill Spreading	
Capacity**				
Earth	2.06 m <sup>3</sup>	2.69 yd <sup>3</sup>	3.73 m <sup>3</sup>	4.88 yd <sup>3</sup>
Weight, Dozer*	1460 kg	3220 lb	2831 kg	6241 lb
General Dimensions: (Tractor & Dozer)				
Length	7.16 m	23'6"	8.56 m	28'1"
Width	3.76 m	12'4"	4.62 m	15'2"
Blade Dimensions:				
Width, End Bits	3.76 m	12'4"	4.62 m	15'2"
Height, Moldboard	860 mm	2'10"	1.03 m	3'4"
Max. Digging Depth	222 mm	8.7"	602 mm	2'0"
Ground Clearance @ Full Lift	802 mm	2'8"	958 mm	3'2"
Tilt Adjust. from Horizontal	328 mm	12.9"	797 mm	31.4"

\*Total Bulldozer Arrangement.

\*\*Blade capacities determined by SAE recommended practice J1265.

**815K and 825K**

**Ground Contact Pressure/Soil Compactors**

<b>815K Tip</b>	<b>Weight Front Axle 9664 kg (21,305 lb) Ground Contact Pressure</b>		<b>Weight Rear Axle 12 722 kg (28,047 lb) Ground Contact Pressure</b>		<b>Contact Area Four Wheels</b>	
	<b>kPa</b>	<b>psi</b>	<b>kPa</b>	<b>psi</b>	<b>cm<sup>2</sup></b>	<b>in<sup>2</sup></b>
Tip Penetration						
12.5 mm (0.5 in)	4727.05	<b>685.6</b>	6989.35	<b>706.7</b>	425.81	<b>66</b>
25 mm (1.0 in)	1347.92	<b>195.5</b>	1827.94	<b>215.7</b>	1445.16	<b>224</b>
38 mm (1.5 in)	902.52	<b>130.9</b>	1094.20	<b>156.8</b>	2077.42	<b>322</b>
50 mm (2.0 in)	658.45	<b>95.5</b>	872.95	<b>97.7</b>	3064.51	<b>475</b>

<b>825K Standard Tip</b>	<b>Weight Front Axle 14 469 kg (31,899 lb) Ground Contact Pressure</b>		<b>Weight Rear Axle 21 059 kg (46,427 lb) Ground Contact Pressure</b>		<b>Contact Area Four Wheels</b>	
	<b>kPa</b>	<b>psi</b>	<b>kPa</b>	<b>psi</b>	<b>cm<sup>2</sup></b>	<b>in<sup>2</sup></b>
Tip Penetration						
12.7 mm (0.5 in)	7178.41	<b>1041.14</b>	8092.55	<b>1173.73</b>	407.65	<b>63.19</b>
25 mm (1.0 in)	2609.39	<b>378.46</b>	2941.72	<b>426.66</b>	1121.55	<b>173.84</b>
38 mm (1.5 in)	1411.35	<b>204.70</b>	1591.10	<b>230.77</b>	2073.54	<b>321.40</b>
50 mm (2.0 in)	704.99	<b>102.25</b>	794.76	<b>115.27</b>	4150.96	<b>643.40</b>
75 mm (3.0 in)	610.19	<b>88.50</b>	687.89	<b>99.77</b>	4795.60	<b>743.32</b>
100 mm (4.0 in)	421.68	<b>61.16</b>	475.39	<b>68.95</b>	6939.86	<b>1075.68</b>
125 mm (5.0 in)	382.52	<b>55.48</b>	431.27	<b>62.55</b>	7650.04	<b>1185.76</b>
150 mm (6.0 in)	324.33	<b>47.04</b>	365.63	<b>53.03</b>	9022.18	<b>1398.44</b>
175 mm (7.0 in)	311.09	<b>45.12</b>	350.74	<b>50.87</b>	9405.66	<b>1457.88</b>
200 mm (8.0 in)	139.55	<b>20.24</b>	157.34	<b>22.82</b>	20 965.89	<b>3249.72</b>

<b>825K Heavy Duty Tip</b>	<b>Weight Front Axle 14 469 kg (31,899 lb) Ground Contact Pressure</b>		<b>Weight Rear Axle 21 059 kg (46,427 lb) Ground Contact Pressure</b>		<b>Contact Area Four Wheels</b>	
	<b>kPa</b>	<b>psi</b>	<b>kPa</b>	<b>psi</b>	<b>cm<sup>2</sup></b>	<b>in<sup>2</sup></b>
Tip Penetration						
12.7 mm (0.5 in)	7615.41	<b>1104.52</b>	8585.20	<b>1245.18</b>	96.07	<b>14.89</b>
25 mm (1.0 in)	6199.83	<b>899.21</b>	6989.35	<b>1013.72</b>	472.00	<b>73.16</b>
38 mm (1.5 in)	3614.20	<b>524.19</b>	1915.27	<b>277.79</b>	430.61	<b>66.74</b>
50 mm (2.0 in)	1621.44	<b>235.17</b>	1827.94	<b>265.12</b>	1804.64	<b>279.72</b>
75 mm (3.0 in)	970.64	<b>140.78</b>	1094.20	<b>158.70</b>	3014.96	<b>467.32</b>
100 mm (4.0 in)	774.28	<b>112.30</b>	872.95	<b>126.61</b>	3779.35	<b>585.80</b>
125 mm (5.0 in)	570.89	<b>82.80</b>	643.56	<b>93.34</b>	5126.18	<b>794.56</b>
150 mm (6.0 in)	443.13	<b>64.27</b>	499.59	<b>72.46</b>	6603.60	<b>1023.56</b>
175 mm (7.0 in)	417.06	<b>60.49</b>	470.22	<b>68.20</b>	7016.24	<b>1087.52</b>
200 mm (8.0 in)	389.07	<b>56.43</b>	438.64	<b>63.62</b>	7520.76	<b>1165.72</b>
225 mm (9.0 in)	381.07	<b>55.27</b>	429.61	<b>62.31</b>	7678.95	<b>1190.24</b>
250 mm (10.0 in)	128.59	<b>18.65</b>	145.00	<b>21.03</b>	22 753.76	<b>3526.84</b>

# WHEEL LOADERS INTEGRATED TOOLCARRIERS

## CONTENTS

Features . . . . .	23-2	988K Rimpull-Speed-Gradeability Charts . . . . .	23-405
Specifications . . . . .	23-3	Travel Time Charts . . . . .	23-406
Performance Data . . . . .	23-19	990K Rimpull-Speed-Gradeability Charts . . . . .	23-408
Machine Dimensions . . . . .	23-232	Travel Time Charts . . . . .	23-409
SAE Loader Ratings . . . . .	23-284	992K Rimpull-Speed-Gradeability Charts . . . . .	23-411
Machine Selection:		Travel Time Charts . . . . .	23-413
Cycle Time Factors . . . . .	23-286	993K Rimpull-Speed-Gradeability Charts . . . . .	23-415
Truck Loading . . . . .	23-287	Travel Time Charts . . . . .	23-417
Bucket Fill Factors . . . . .	23-287	994K Rimpull-Speed-Gradeability Charts . . . . .	23-421
Example Problem . . . . .	23-288	Travel Time Charts . . . . .	23-422
Alternative Method of Selection . . . . .	23-289	Production Estimating Tables:	
Nomographs . . . . .	23-290	Cubic Meters and Cubic Yards . . . . .	23-424
Machine/Attachment Selection . . . . .	23-292	Metric Tons and U.S. Tons in Shot Rock . . . . .	23-425
Buckets . . . . .	23-299	Attachments:	
Bucket Selection . . . . .	23-326	Wheel Loaders . . . . .	23-427
Travel Time Charts . . . . .	23-367	Integrated Toolcarriers . . . . .	23-429
		Fusion™ Coupler System . . . . .	23-430
		Attachments . . . . .	23-431

### WHEEL LOADERS

#### Features:

- Cat® heavy duty diesel engine.
- Productive operator environment. Excellent visibility.
- Automatic lift and bucket controls.
- Adjustable suspension seat and steering column.
- Four wheel enclosed wet disc brakes.
- Automatic power shift transmissions. Allows operator to select automatic or manual mode.
- Hydrostatic drive on 903C2, 906K/M, 907K/M, 908K/M, 910K/M, 914K/M, 918M, 924K, 926M, 930K/M and 938K/M.
- Transmission neutralizer switch (950H-980H, 950K-980K, 950L-980L and 950M-982M).
- Advanced power train with continuously variable transmission available on the 966M XE and 972M XE.
- Computerized machine function monitoring.
- Command control steering with integrated transmission controls and electro-hydraulic controls ... 950H-980H.
- Electro-Hydraulic (EH) Joystick Steering with Force Feedback (Speed Sensitive) on 966K, 966M, 972K, 972M, 980K, 980M and 982M (optional on 950M and 962M).
- Lock up clutch on 950L, 950M, 962L, 962M, 966L, 966M, 972L, 972M, 980L, 980M, 982M, 988K, 990K and 994K (optional on the 980K, 992K and 993K).
- Impeller clutch on 988K, 990K, 992K, 993K and 994K.
- Tilting hood ... 950H-980H, 950K-980K, 950L-980L and 950M-982M.
- Brake wear indicator.
- Limited slip differentials on 924K, 926M, 930K/M, 938K/M (optional on 950H-980H, 950K-980K, 980L, 980M and 982M).
- Differential locks ... 903C2, 906K/M, 907K/M, 908K/M, 910K/M, 914K/M, 918M, 924K, 926M, 930K/M, 938K/M, 950M, 962M, 966M and 972M (optional on 950L, 962L, 966L and 972L).
- Automatic Ride Control suspension system. Operator select “on,” “off” or “automatic” (excluding 903C2).
- Payload control system (excluding models below 924K).
- Optional Fusion coupler system for attachment interchangeability with pin-on performance. Attachments can interchange across the entire SWL/MWL/IT line (excluding models below 924K).
- Performance Series Buckets — Reduced dig times and better material retention lead to significant productivity and fuel efficiency improvements (910K/M, 914K/M, 918M, 924K, 926M, 930K/M, 938K/M, 950H-980H, 950K- 980K, 950L-980L and 950M-982M).

Listed features may be standard on some models, optional or unavailable on others. Contact your Cat dealer for specific information.

<b>MODEL</b>	<b>903C2</b>		
Flywheel Power: Net	30 kW		40 hp
Gross	31 kW		42 hp
Engine Model		<b>C2.4*</b>	
Rated Engine RPM		<b>2200</b>	
Bore	87 mm		3.4"
Stroke	102 mm		4.0"
No. Cylinders		<b>4</b>	
Displacement	2.4 L		147 in <sup>3</sup>
Forward Speed	16 km/h		10 mph
Reverse Speed	16 km/h		10 mph
Hydraulic Cycle Time, Rated Load in Bucket:		<b>Seconds</b>	
Raise		<b>4.8</b>	
Dump		<b>0.8</b>	
Lower		<b>3.2</b>	
Total		<b>8.8</b>	
Tread Width	1314 mm		4'4"
Width Over Tires	1708 mm		5'7"
Ground Clearance	395 mm		1'4"
Fuel Tank Capacity	43 L		11.4 U.S. gal
Hydraulic System Capacity (includes tank)	24 L		6.3 U.S. gal

\*These machines meet U.S. EPA Tier 4 Final emission standards and are only available in certain regions. Contact your local Cat dealer for product availability.

<b>MODEL</b>	<b>906K/M</b>		<b>907K/M</b>		<b>908K/M</b>	
Flywheel Power: Net	52 kW	<b>70 hp</b>	52 kW	<b>70 hp</b>	52 kW	<b>70 hp</b>
Gross	55 kW	<b>74 hp</b>	55 kW	<b>74 hp</b>	55 kW	<b>74 hp</b>
Engine Model	<b>C3.3B*</b>		<b>C3.3B*</b>		<b>C3.3B*</b>	
Rated Engine RPM	<b>2500</b>		<b>2500</b>		<b>2500</b>	
Bore	94 mm	<b>3.7"</b>	94 mm	<b>3.7"</b>	94 mm	<b>3.7"</b>
Stroke	120 mm	<b>4.72"</b>	120 mm	<b>4.72"</b>	120 mm	<b>4.72"</b>
No. Cylinders	<b>4</b>		<b>4</b>		<b>4</b>	
Displacement	3.331 L	<b>203.3 in<sup>3</sup></b>	3.331 L	<b>203.3 in<sup>3</sup></b>	3.331 L	<b>203.3 in<sup>3</sup></b>
Speeds Forward:	<b>km/h</b>	<b>mph</b>	<b>km/h</b>	<b>mph</b>	<b>km/h</b>	<b>mph</b>
Speed 1	10	<b>6</b>	10	<b>6</b>	10	<b>6</b>
Speed 2	20	<b>12</b>	20	<b>12</b>	20	<b>12</b>
High Speed	35	<b>22</b>	35	<b>22</b>	35	<b>22</b>
Speeds Reverse:	<b>km/h</b>	<b>mph</b>	<b>km/h</b>	<b>mph</b>	<b>km/h</b>	<b>mph</b>
1st	10	<b>6</b>	10	<b>6</b>	10	<b>6</b>
2nd	20	<b>12</b>	20	<b>12</b>	20	<b>12</b>
High Speed	35	<b>22</b>	35	<b>22</b>	35	<b>22</b>
Hydraulic Cycle Time, Rated Load in Bucket:	<b>Seconds</b>		<b>Seconds</b>		<b>Seconds</b>	
Raise	<b>5</b>		<b>5</b>		<b>5</b>	
Dump	<b>2</b>		<b>2</b>		<b>2</b>	
Lower (Empty, Float Down)	<b>4</b>		<b>4</b>		<b>4</b>	
Total	<b>11</b>		<b>11</b>		<b>11</b>	
Tread Width	1420 mm	<b>4'8"</b>	1420 mm	<b>4'8"</b>	1590 mm	<b>5'2"</b>
Width Over Tires	1820 mm	<b>5'11"</b>	1820 mm	<b>5'11"</b>	1993 mm	<b>6'6"</b>
Ground Clearance	301 mm	<b>12"</b>	301 mm	<b>12"</b>	340 mm	<b>14"</b>
Fuel Tank Capacity	52 L	<b>13.7 U.S. gal</b>	78 L	<b>20.6 U.S. gal</b>	78 L	<b>20.6 U.S. gal</b>
Hydraulic Tank Capacity	59 L	<b>15.5 U.S. gal</b>	59 L	<b>15.5 U.S. gal</b>	59 L	<b>15.5 U.S. gal</b>
Hydraulic System Capacity (includes tank)	70 L	<b>18.5 U.S. gal</b>	70 L	<b>18.5 U.S. gal</b>	70 L	<b>18.5 U.S. gal</b>

\*Depending on region, these models meet U.S. EPA Tier 4 Final/EU Stage IIIB, Tier 4 Interim/Stage IIIA equivalent, or Tier 2/Stage II equivalent emission standards. Contact your local Cat dealer for product availability.

MODEL	910K/M		914K/M		918M	
Flywheel Power:						
Gross (SAE J1995)	76 kW	<b>102 hp</b>	76 kW	<b>102 hp</b>	87 kW	<b>117 hp</b>
Maximum Gross Power:						
ISO 14396	74 kW	<b>100 hp</b>	74 kW	<b>100 hp</b>	86 kW	<b>115 hp</b>
ISO 14396 (DIN)	74 kW	<b>101 hp</b>	74 kW	<b>101 hp</b>	86 kW	<b>117 hp</b>
Rated Net Power:						
SAE J1349	72 kW	<b>96 hp</b>	72 kW	<b>96 hp</b>	83 kW	<b>112 hp</b>
ISO 9249 EEC	72 kW	<b>97 hp</b>	72 kW	<b>97 hp</b>	84 kW	<b>113 hp</b>
ISO 9249 (DIN)	72 kW	<b>98 hp</b>	72 kW	<b>98 hp</b>	84 kW	<b>114 hp</b>
Engine Model	<b>C4.4 ACERT™*</b>		<b>C4.4 ACERT*</b>		<b>C4.4 ACERT*</b>	
Rated Engine RPM	<b>2200</b>		<b>2200</b>		<b>2200</b>	
Bore	105 mm	<b>4.13"</b>	105 mm	<b>4.13"</b>	105 mm	<b>4.13"</b>
Stroke	127 mm	<b>5.00"</b>	127 mm	<b>5.00"</b>	127 mm	<b>5.00"</b>
No. Cylinders	<b>4</b>		<b>4</b>		<b>4</b>	
Displacement	4.4 L	<b>268 in<sup>3</sup></b>	4.4 L	<b>268 in<sup>3</sup></b>	4.4 L	<b>268 in<sup>3</sup></b>
Speeds Forward:	<b>km/h</b>	<b>mph</b>	<b>km/h</b>	<b>mph</b>	<b>km/h</b>	<b>mph</b>
1st	10	<b>6.3</b>	10	<b>6.3</b>	10	<b>6.3</b>
2nd	20	<b>12.5</b>	20	<b>12.5</b>	20	<b>12.5</b>
High**	40	<b>25</b>	40	<b>25</b>	40	<b>25</b>
Speeds Reverse:	<b>km/h</b>	<b>mph</b>	<b>km/h</b>	<b>mph</b>	<b>km/h</b>	<b>mph</b>
1st	10	<b>6.3</b>	10	<b>6.3</b>	10	<b>6.3</b>
2nd	20	<b>12.5</b>	20	<b>12.5</b>	20	<b>12.5</b>
High**	40	<b>25</b>	40	<b>25</b>	40	<b>25</b>
Hydraulic Cycle Time, Rated Load in Bucket:	<b>Seconds</b>		<b>Seconds</b>		<b>Seconds</b>	
Raise	<b>5.2</b>		<b>5.2</b>		<b>4.8</b>	
Dump	<b>1.4</b>		<b>1.4</b>		<b>1.8</b>	
Lower	<b>3.7</b>		<b>3.7</b>		<b>2.7</b>	
Total	<b>10.3</b>		<b>10.3</b>		<b>9.3</b>	
Tread Width	1800 mm	<b>5'10"</b>	1800 mm	<b>5'10"</b>	1800 mm	<b>5'10"</b>
Width Over Tires	2259 mm	<b>7'4"</b>	2259 mm	<b>7'4"</b>	2259 mm	<b>7'4"</b>
Ground Clearance	348 mm	<b>1'1"</b>	405 mm	<b>1'3"</b>	348 mm	<b>1'1"</b>
Fuel Tank Capacity	154 L	<b>40.7 U.S. gal</b>	154 L	<b>40.7 U.S. gal</b>	154 L	<b>40.7 U.S. gal</b>
Hydraulic System Capacity (includes tank)	98 L	<b>25.9 U.S. gal</b>	98 L	<b>25.9 U.S. gal</b>	98 L	<b>25.9 U.S. gal</b>

\*Depending on region, these machines meet Tier 4 Final/Stage IV or Tier 3/Stage IIIA equivalent emission standards. Contact your local Cat dealer for product availability.

\*\*Not available in all regions.



<b>MODEL</b>	<b>926M*** Standard and High Lift Pin On/Hook On</b>		<b>930M*** Standard and High Lift Pin On/Hook On</b>		<b>938M*** Standard and High Lift Pin On/Hook On</b>	
Flywheel Power	110 kW	<b>148 hp</b>	117 kW	<b>157 hp</b>	136 kW	<b>182 hp</b>
Rated Power	114 kW	<b>153 hp</b>	122 kW	<b>166 hp</b>	140 kW	<b>190 hp</b>
Engine Model	<b>C7.1 ACERT</b>		<b>C7.1 ACERT</b>		<b>C7.1 ACERT</b>	
Rated Engine RPM	<b>1800</b>		<b>1800</b>		<b>1800</b>	
Bore	105 mm	<b>4.13"</b>	105 mm	<b>4.13"</b>	105 mm	<b>4.13"</b>
Stroke	135 mm	<b>5.31"</b>	135 mm	<b>5.31"</b>	135 mm	<b>5.31"</b>
No. Cylinders	<b>6</b>		<b>6</b>		<b>6</b>	
Displacement	7.01 L	<b>427 in<sup>3</sup></b>	7.01 L	<b>427 in<sup>3</sup></b>	7.01 L	<b>427 in<sup>3</sup></b>
Speeds Forward and Reverse:	<b>km/h</b>	<b>mph</b>	<b>km/h</b>	<b>mph</b>	<b>km/h</b>	<b>mph</b>
1st	1.0-13.0	<b>0.6-8.0</b>	1.0-13.0	<b>0.6-8.0</b>	1.0-13.0	<b>0.6-8.0</b>
2nd	13.0	<b>8.0</b>	13.0	<b>8.0</b>	13.0	<b>8.0</b>
3rd	27.0	<b>17.0</b>	27.0	<b>17.0</b>	27.0	<b>17.0</b>
4th	40.0	<b>25.0</b>	40.0	<b>25.0</b>	40.0	<b>25.0</b>
Hydraulic Cycle Time, Rated Load in Bucket:*	<b>Seconds</b>		<b>Seconds</b>		<b>Seconds</b>	
Raise	<b>5.5</b>		<b>5.5</b>		<b>5.5</b>	
Dump	<b>1.5</b>		<b>1.5</b>		<b>1.5</b>	
Lower (Empty, Float Down)	<b>2.6</b>		<b>2.6</b>		<b>2.6</b>	
Total	<b>9.6</b>		<b>9.6</b>		<b>9.6</b>	
Tread Width**	1.93 m	<b>6'3"</b>	1.93 m	<b>6'3"</b>	2.08 m	<b>6'10"</b>
Width Over Tires**	2.54 m	<b>8'4"</b>	2.54 m	<b>8'4"</b>	2.69 m	<b>8'10"</b>
Ground Clearance**	397 mm	<b>1'4"</b>	397 mm	<b>1'4"</b>	386 mm	<b>1'3"</b>
Fuel Tank Capacity	195 L	<b>51.5 U.S. gal</b>	195 L	<b>51.5 U.S. gal</b>	195 L	<b>51.5 U.S. gal</b>
Hydraulic Tank Capacity	90 L	<b>23.8 U.S. gal</b>	90 L	<b>23.8 U.S. gal</b>	90 L	<b>23.8 U.S. gal</b>
Hydraulic System Capacity (includes tank)	160 L	<b>42.3 U.S. gal</b>	160 L	<b>42.3 U.S. gal</b>	160 L	<b>42.3 U.S. gal</b>

\*With standard lift arms.

\*\*With standard tires.

\*\*\*Meets Tier 4 Final/Stage IV/Japan 2014 (Tier 4 Final) emission standards.

**NOTE:** Dimensions listed are for a machine configured with Fusion work tool, counterweights, additional guarding, 80 kg (176 lb) operator, and Michelin 20.5 R25 (L-3) XHA2 tires.

<b>MODEL</b>	<b>924K Standard and High Lift Pin On/Hook On</b>		<b>930K Standard and High Lift Pin On/Hook On</b>		<b>938K Standard and High Lift Pin On/Hook On</b>	
Flywheel Power	101 kW	<b>135 hp</b>	115 kW	<b>154 hp</b>	136 kW	<b>182 hp</b>
Rated Power	105 kW	<b>141 hp</b>	119 kW	<b>160 hp</b>	140 kW	<b>188 hp</b>
Engine Model	<b>C7.1 ACERT</b>		<b>C7.1 ACERT</b>		<b>C7.1 ACERT</b>	
Rated Engine RPM	<b>1800</b>		<b>1800</b>		<b>1800</b>	
Bore	105 mm	<b>4.13"</b>	105 mm	<b>4.13"</b>	105 mm	<b>4.13"</b>
Stroke	135 mm	<b>5.31"</b>	135 mm	<b>5.31"</b>	135 mm	<b>5.31"</b>
No. Cylinders	<b>6</b>		<b>6</b>		<b>6</b>	
Displacement	7.01 L	<b>427 in<sup>3</sup></b>	7.01 L	<b>427 in<sup>3</sup></b>	7.01 L	<b>427 in<sup>3</sup></b>
Speeds Forward and Reverse:	<b>km/h</b>	<b>mph</b>	<b>km/h</b>	<b>mph</b>	<b>km/h</b>	<b>mph</b>
1st	1.0-13.0	<b>0.6-8.0</b>	1.0-13.0	<b>0.6-8.0</b>	1.0-13.0	<b>0.6-8.0</b>
2nd	13.0	<b>8.0</b>	13.0	<b>8.0</b>	13.0	<b>8.0</b>
3rd	27.0	<b>17.0</b>	27.0	<b>17.0</b>	27.0	<b>17.0</b>
4th	40.0	<b>25.0</b>	40.0	<b>25.0</b>	40.0	<b>25.0</b>
Hydraulic Cycle Time, Rated Load in Bucket:*	<b>Seconds</b>		<b>Seconds</b>		<b>Seconds</b>	
Raise	<b>5.4</b>		<b>5.1</b>		<b>5.5</b>	
Dump	<b>1.5</b>		<b>1.5</b>		<b>1.5</b>	
Lower (Empty, Float Down)	<b>2.6</b>		<b>2.7</b>		<b>2.7</b>	
Total	<b>9.5</b>		<b>9.3</b>		<b>9.7</b>	
Tread Width**	1.93 m	<b>6'3"</b>	1.93 m	<b>6'3"</b>	2.08 m	<b>6'10"</b>
Width Over Tires**	2.54 m	<b>8'4"</b>	2.54 m	<b>8'4"</b>	2.69 m	<b>8'10"</b>
Ground Clearance**	397 mm	<b>1'4"</b>	397 mm	<b>1'4"</b>	386 mm	<b>1'3"</b>
Fuel Tank Capacity	195 L	<b>51.5 U.S. gal</b>	195 L	<b>51.5 U.S. gal</b>	195 L	<b>51.5 U.S. gal</b>
Hydraulic Tank Capacity	90 L	<b>23.8 U.S. gal</b>	90 L	<b>23.8 U.S. gal</b>	90 L	<b>23.8 U.S. gal</b>
Hydraulic System Capacity (includes tank)	160 L	<b>42.3 U.S. gal</b>	165 L	<b>43.6 U.S. gal</b>	170 L	<b>44.9 U.S. gal</b>

\*With standard lift arms.

\*\*With standard tires.

**NOTE:** Dimensions listed are for a machine configured with Fusion work tool, counterweights, additional guarding, 80 kg (176 lb) operator, and Michelin 20.5 R25 (L-3) XHA2 tires.

<b>MODEL</b>	<b>950M</b>		<b>962M</b>		<b>966M</b>	
Emission Standards	<b>Tier 4 Final*</b>		<b>Tier 4 Final*</b>		<b>Tier 4 Final*</b>	
Maximum Engine: Net	171 kW	<b>230 hp</b>	186 kW	<b>250 hp</b>	206 kW	<b>276 hp</b>
Gross	187 kW	<b>250 hp</b>	202 kW	<b>271 hp</b>	232 kW	<b>311 hp</b>
Engine Model	<b>C7.1 ACERT</b>		<b>C7.1 ACERT</b>		<b>C9.3 ACERT</b>	
Maximum Net Power Engine RPM	<b>2100</b>		<b>2100</b>		<b>1700</b>	
Bore	105 mm	<b>4.1"</b>	105 mm	<b>4.1"</b>	115 mm	<b>4.53"</b>
Stroke	135 mm	<b>5.3"</b>	135 mm	<b>5.3"</b>	149 mm	<b>5.87"</b>
No. Cylinders	<b>6</b>		<b>6</b>		<b>6</b>	
Displacement	7.01 L	<b>427.8 in<sup>3</sup></b>	7.01 L	<b>427.8 in<sup>3</sup></b>	9.3 L	<b>568 in<sup>3</sup></b>
Speeds Forward:	<b>km/h</b>	<b>mph</b>	<b>km/h</b>	<b>mph</b>	<b>km/h</b>	<b>mph</b>
1st	6.9	<b>4.3</b>	6.9	<b>4.3</b>	6.5	<b>4.0</b>
2nd	12.0	<b>7.5</b>	12.0	<b>7.5</b>	13.0	<b>8.1</b>
3rd	19.3	<b>12.0</b>	19.3	<b>12.0</b>	23.5	<b>14.6</b>
4th	25.7	<b>16.0</b>	25.7	<b>16.0</b>	39.5	<b>24.5</b>
5th	39.5	<b>24.5</b>	39.5	<b>24.5</b>	—	
Speeds Reverse:	<b>km/h</b>	<b>mph</b>	<b>km/h</b>	<b>mph</b>	<b>km/h</b>	<b>mph</b>
1st	6.9	<b>4.3</b>	6.9	<b>4.3</b>	7.1	<b>4.4</b>
2nd	12.0	<b>7.5</b>	12.0	<b>7.5</b>	14.4	<b>8.9</b>
3rd	25.7	<b>16.0</b>	25.7	<b>16.0</b>	25.9	<b>16.1</b>
4th	—		—		39.0	<b>24.2</b>
Hydraulic Cycle Time, Rated Load in Bucket:	<b>Seconds</b>		<b>Seconds</b>		<b>Seconds</b>	
Raise (from Carry Position)	<b>5.3</b>		<b>5.4</b>		<b>5.5</b>	
Dump (at Maximum Raise)	<b>1.5</b>		<b>1.5</b>		<b>1.4</b>	
Lower (Empty, Float Down)	<b>2.3</b>		<b>2.7</b>		<b>2.6</b>	
Total	<b>9.1</b>		<b>9.6</b>		<b>9.5</b>	
Tread Width	2140 mm	<b>7'0"</b>	2140 mm	<b>7'0"</b>	2230 mm	<b>7'4"</b>
Width Over Tires	2790 mm	<b>9'2"</b>	2790 mm	<b>9'2"</b>	2991 mm	<b>9'10"</b>
Ground Clearance	385 mm	<b>1'3"</b>	385 mm	<b>1'3"</b>	476 mm	<b>1'7"</b>
Fuel Tank Capacity	275 L	<b>72.6 U.S. gal</b>	275 L	<b>72.6 U.S. gal</b>	303 L	<b>80.0 U.S. gal</b>
DEF Tank Capacity	16 L	<b>4.2 U.S. gal</b>	16 L	<b>4.2 U.S. gal</b>	16.8 L	<b>4.4 U.S. gal</b>
Hydraulic Tank Capacity	125 L	<b>33 U.S. gal</b>	125 L	<b>33 U.S. gal</b>	125 L	<b>33 U.S. gal</b>

\*Meets Tier 4 Final, Stage IV and Japan 2014 (Tier 4 Final) emission standards.

**NOTE:** Net Engine Power is provided according to SAE J1349 and ISO 9249. Gross Engine Power is provided according to SAE J1995. Machines may only be available in certain regions. Contact your local Cat dealer for product availability.

MODEL	966M XE		972M		972M XE	
Emission Standards	Tier 4 Final*		Tier 4 Final*		Tier 4 Final*	
Maximum Engine: Net	222 kW	298 hp	223 kW	299 hp	232 kW	311 hp
Gross	—		251 kW	337 hp	—	
Engine Model	C9.3 ACERT		C9.3 ACERT		C9.3 ACERT	
Maximum Net Power Engine RPM	1600		1700		1600	
Bore	115 mm	4.53"	115 mm	4.53"	115 mm	4.53"
Stroke	149 mm	5.87"	149 mm	5.87"	149 mm	5.87"
No. Cylinders	6		6		6	
Displacement	9.3 L	568 in <sup>3</sup>	9.3 L	568 in <sup>3</sup>	9.3 L	568 in <sup>3</sup>
Speeds Forward:	km/h	mph	km/h	mph	km/h	mph
1st	6.7	4.2	6.7	4.2	6.7	4.2
2nd	12.6	7.8	13.1	8.1	12.6	7.8
3rd	22.1	13.7	23.2	14.4	22.1	13.7
4th	39.5	24.5	39.5	24.5	39.5	24.5
5th	—		—		—	
Speeds Reverse:	km/h	mph	km/h	mph	km/h	mph
1st	6.7	4.2	7.6	4.7	6.7	4.2
2nd	12.6	7.8	15.0	8.9	12.6	7.8
3rd	28.0	17.4	26.5	16.5	28.0	17.4
4th	—		39.5	24.5	—	
Hydraulic Cycle Time, Rated Load in Bucket:	Seconds		Seconds		Seconds	
Raise (from Carry Position)	5.5		5.5		5.5	
Dump (at Maximum Raise)	1.4		1.5		1.5	
Lower (Empty, Float Down)	2.6		3.1		3.1	
Total	9.5		10.1		10.1	
Tread Width	2230 mm	7'4"	2230 mm	7'4"	2230 mm	7'4"
Width Over Tires	2991 mm	9'10"	2991 mm	9'10"	2991 mm	9'10"
Ground Clearance	476 mm	1'7"	476 mm	1'7"	476 mm	1'7"
Fuel Tank Capacity	303 L	80.0 U.S. gal	303 L	80.0 U.S. gal	303 L	80.0 U.S. gal
DEF Tank Capacity	16.8 L	4.4 U.S. gal	16.8 L	4.4 U.S. gal	16.8 L	4.4 U.S. gal
Hydraulic Tank Capacity	125 L	33 U.S. gal	125 L	33 U.S. gal	125 L	33 U.S. gal

\*Meets Tier 4 Final, Stage IV and Japan 2014 (Tier 4 Final) emission standards.

**NOTE:** Net Engine Power is provided according to SAE J1349 and ISO 9249. Gross Engine Power is provided according to SAE J1995. Machines may only be available in certain regions. Contact your local Cat dealer for product availability.

<b>MODEL</b>	<b>980M</b>		<b>982M</b>	
Emission Standards	<b>Tier 4 Final*</b>		<b>Tier 4 Final*</b>	
Maximum Engine: Net	288 kW	<b>386 hp</b>	292 kW	<b>392 hp</b>
Gross	317 kW	<b>425 hp</b>	325 kW	<b>436 hp</b>
Engine Model	<b>C13 ACERT</b>		<b>C13 ACERT</b>	
Maximum Net Power Engine RPM	<b>1700</b>		<b>1700</b>	
Bore	130 mm	<b>5.1"</b>	130 mm	<b>5.1"</b>
Stroke	157 mm	<b>6.2"</b>	157 mm	<b>6.2"</b>
No. Cylinders	<b>6</b>		<b>6</b>	
Displacement	12.5 L	<b>762.8 in<sup>3</sup></b>	12.5 L	<b>762.8 in<sup>3</sup></b>
Speeds Forward:	<b>km/h</b>	<b>mph</b>	<b>km/h</b>	<b>mph</b>
1st	6.9	<b>4.3</b>	6.2	<b>3.9</b>
2nd	13.3	<b>8.3</b>	11.9	<b>7.4</b>
3rd	23.5	<b>14.6</b>	21.1	<b>13.1</b>
4th	39.5	<b>24.5</b>	37.5	<b>23.3</b>
5th	—		—	
Speeds Reverse:	<b>km/h</b>	<b>mph</b>	<b>km/h</b>	<b>mph</b>
1st	7.8	<b>4.8</b>	7.0	<b>4.3</b>
2nd	15.2	<b>9.4</b>	13.6	<b>8.5</b>
3rd	26.9	<b>16.7</b>	24.1	<b>15.0</b>
4th	39.5	<b>24.5</b>	39.5	<b>24.5</b>
Hydraulic Cycle Time, Rated Load in Bucket:	<b>Seconds</b>		<b>Seconds</b>	
Raise (from Carry Position)	<b>5.3</b>		<b>5.3</b>	
Dump (at Maximum Raise)	<b>1.7</b>		<b>1.7</b>	
Lower (Empty, Float Down)	<b>3.1</b>		<b>3.1</b>	
Total	<b>10.1</b>		<b>10.1</b>	
Tread Width	2440 mm	<b>8'0"</b>	2540 mm	<b>8'4"</b>
Width Over Tires	3265 mm	<b>10'9"</b>	3452 mm	<b>11'4"</b>
Ground Clearance	453 mm	<b>1'6"</b>	426 mm	<b>1'5"</b>
Fuel Tank Capacity	426 L	<b>112.5 U.S. gal</b>	426 L	<b>112.5 U.S. gal</b>
DEF Tank Capacity	21 L	<b>5.5 U.S. gal</b>	21 L	<b>5.5 U.S. gal</b>
Hydraulic Tank Capacity	180 L	<b>48 U.S. gal</b>	180 L	<b>48 U.S. gal</b>

\*Meets Tier 4 Final, Stage IV and Japan 2014 (Tier 4 Final) emission standards.

**NOTE:** Net Engine Power is provided according to SAE J1349 and ISO 9249. Gross Engine Power is provided according to SAE J1995. Machines may only be available in certain regions. Contact your local Cat dealer for product availability.

MODEL	950K		962K		966K	
Emission Standards	Tier 4 Interim equivalent*		Tier 4 Interim equivalent*		Tier 4 Interim equivalent*	
Maximum Engine: Net	157 kW	210 hp	165 kW	222 hp	199 kW	267 hp
Gross	173 kW	232 hp	181 kW	243 hp	222 kW	296 hp
Engine Model	C7.1 ACERT		C7.1 ACERT		C9.3 ACERT	
Maximum Net Power Engine RPM	1900		1900		1800	
Bore	105 mm	4.1"	105 mm	4.1"	115 mm	4.5"
Stroke	135 mm	5.3"	135 mm	5.3"	149 mm	5.9"
No. Cylinders	6		6		6	
Displacement	7.01 L	427.8 in <sup>3</sup>	7.01 L	427.8 in <sup>3</sup>	9.3 L	568 in <sup>3</sup>
Speeds Forward:	km/h	mph	km/h	mph	km/h	mph
1st	6.9	4.3	6.9	4.3	6.7	4.2
2nd	12.9	8.0	12.9	8.0	12.6	7.8
3rd	22.7	14.1	22.7	14.1	22.4	13.9
4th	37.9	23.6	37.9	23.6	37.4	23.2
Speeds Reverse:	km/h	mph	km/h	mph	km/h	mph
1st	7.5	4.7	7.5	4.7	7.8	4.9
2nd	14.1	8.8	14.1	8.8	13.7	8.5
3rd	24.8	15.4	24.8	15.4	23.5	14.6
4th	39.8	24.7	39.8	24.7	38.5	23.9
Hydraulic Cycle Time, Rated Load in Bucket:	Seconds		Seconds		Seconds	
Raise (from Carry Position)	5.9		5.9		5.9	
Dump (at Maximum Raise)	1.8		1.8		1.5	
Lower (Empty, Float Down)	2.5		2.5		2.4	
Total	10.0		10.0		9.8	
Tread Width	2.14 m	7'0"	2.14 m	7'0"	2.23 m	7'4"
Width Over Tires	2.79 m	9'2"	2.79 m	9'2"	3.01 m	9'11"
Ground Clearance	397 mm	1'3"	397 mm	1'3"	475 mm	1'6"
Fuel Tank Capacity	314 L	83 U.S. gal	314 L	83 U.S. gal	381 L	101 U.S. gal
Hydraulic Tank Capacity	137 L	36 U.S. gal	137 L	36 U.S. gal	137 L	36 U.S. gal
Hydraulic System Capacity (includes tank)	189 L	50 U.S. gal	189 L	50 U.S. gal	200 L	52 U.S. gal

\*Meets Tier 4 Interim, Stage IIIB, and Japan 2011 (Tier 4 Interim) equivalent emission standards.

**NOTE:** Net Engine Power is provided according to SAE J1349 and ISO 9249. Gross Engine Power is provided according to SAE J1995. Machines may only be available in certain regions. Contact your local Cat dealer for product availability.

<b>MODEL</b>	<b>972K</b>		<b>980K</b>		<b>988K</b>	
Emission Standards	<b>Tier 4 Interim equivalent*</b>		<b>Tier 4 Interim equivalent*</b>		<b>Tier 4 Final or Tier 3 equivalent or Tier 2 equivalent**</b>	
Maximum Engine: Net	215 kW	<b>289 hp</b>	274 kW	<b>369 hp</b>	403 kW	<b>541 hp</b>
Gross	237 kW	<b>318 hp</b>	303 kW	<b>407 hp</b>	432 kW	<b>580 hp</b>
Rated Payload***	—		—		11.3 tonnes	<b>12.5 tons</b>
Gross Rated Bucket Payload***	—		—		17 070 kg	<b>37,632 lb</b>
Engine Model	<b>C9.3 ACERT</b>		<b>C13 ACERT</b>		<b>C18 ACERT</b>	
Maximum Net Power Engine RPM	<b>1800</b>		<b>1600</b>		<b>1700</b>	
Bore	115 mm	<b>4.5"</b>	130 mm	<b>5.1"</b>	145 mm	<b>5.7"</b>
Stroke	149 mm	<b>5.9"</b>	157 mm	<b>6.2"</b>	183 mm	<b>7.2"</b>
No. Cylinders	<b>6</b>		<b>6</b>		<b>6</b>	
Displacement	9.3 L	<b>568 in<sup>3</sup></b>	12.5 L	<b>762.8 in<sup>3</sup></b>	18.1 L	<b>1104.5 in<sup>3</sup></b>
Speeds Forward:	<b>km/h</b>	<b>mph</b>	<b>km/h</b>	<b>mph</b>	<b>km/h</b>	<b>mph</b>
1st	7.0	<b>4.4</b>	6.9	<b>4.3</b>	6.5	<b>4.0</b>
2nd	12.5	<b>7.8</b>	12.2	<b>7.6</b>	11.6	<b>7.2</b>
3rd	21.4	<b>13.3</b>	21.3	<b>13.2</b>	20.4	<b>12.7</b>
4th	36.9	<b>22.9</b>	37.2	<b>23.1</b>	34.7	<b>21.6</b>
Speeds Reverse:	<b>km/h</b>	<b>mph</b>	<b>km/h</b>	<b>mph</b>	<b>km/h</b>	<b>mph</b>
1st	8.0	<b>5.0</b>	7.8	<b>4.8</b>	7.5	<b>4.7</b>
2nd	14.3	<b>8.9</b>	13.8	<b>8.6</b>	13.3	<b>8.3</b>
3rd	24.5	<b>15.2</b>	24.2	<b>15.1</b>	23.2	<b>14.4</b>
4th	42.2	<b>26.2</b>	42.4	<b>26.3</b>	—	
Hydraulic Cycle Time, Rated Load in Bucket:	<b>Seconds</b>		<b>Seconds</b>		<b>Seconds</b>	
Raise****	<b>5.9</b>		<b>6.4</b>		<b>8.0</b>	
Dump (at Maximum Raise)	<b>2.0</b>		<b>1.7</b>		<b>2.2</b>	
Lower (Empty, Float Down)	<b>2.4</b>		<b>3.3</b>		<b>3.5</b>	
Total	<b>10.3</b>		<b>11.4</b>		<b>13.7</b>	
Tread Width	2.23 m	<b>7'4"</b>	2.44 m	<b>8'0"</b>	2.59 m	<b>8'6"</b>
Width Over Tires	3.02 m	<b>9'11"</b>	3307 mm	<b>10'9"</b>	3.62 m	<b>11'11"</b>
Ground Clearance	475 mm	<b>1'6"</b>	460 mm	<b>1'6"</b>	556 mm	<b>22"</b>
Fuel Tank Capacity	381 L	<b>101 U.S. gal</b>	447 L	<b>118.1 U.S. gal</b>	712 L	<b>188 U.S. gal</b>
Hydraulic Tank Capacity	137 L	<b>36 U.S. gal</b>	156 L	<b>41 U.S. gal</b>	240 L	<b>63 U.S. gal</b>
Hydraulic System Capacity (includes tank)	200 L	<b>52 U.S. gal</b>	271 L	<b>72 U.S. gal</b>	475 L	<b>125 U.S. gal</b>

\*Meets Tier 4 Interim, Stage IIIB, and Japan 2011 (Tier 4 Interim) equivalent emission standards.

\*\*Meets Tier 4 Final/Stage IV OR Tier 3/Stage IIIA equivalent OR Tier 2/Stage II equivalent emission standards.

\*\*\*Changes in bucket weight, including field installed wear iron, can impact rated payload. Consult your Cat dealer for assistance in selecting and configuring the proper bucket for the application. The Cat Large Wheel Loader Payload Policy is a guideline intended to maximize wheel loader structural and component life. The Cat Payload Policy is that the "Gross Bucket plus Payload Capacity" is the MAXIMUM weight that should be carried on the end of the Lift Arm/Boom.

\*\*\*\*Raise is from carry position for the 972K and 980K.

**NOTE:** For 972K and 980K, Net Engine Power is provided according to SAE J1349 and ISO 9249. Gross Engine Power is provided according to SAE J1995.

MODEL	950 GC		950M		950L	
Emission Standards	Tier 3 equivalent*		Tier 3 equivalent*		Tier 3 equivalent*	
Maximum Engine: Net	154 kW	207 hp	185 kW	248 hp	185 kW	248 hp
Gross	171 kW	229 hp	196 kW	262 hp	196 kW	262 hp
Engine Model	C7.1		C7.1 ACERT		C7.1 ACERT	
Maximum Net Power Engine RPM	2000		2000		2000	
Bore	105 mm	4.1"	105 mm	4.1"	105 mm	4.1"
Stroke	135 mm	5.3"	135 mm	5.3"	135 mm	5.3"
No. Cylinders	6		6		6	
Displacement	7.01 L	427.8 in <sup>3</sup>	7.01 L	427.8 in <sup>3</sup>	7.01 L	427.8 in <sup>3</sup>
Speeds Forward:	km/h	mph	km/h	mph	km/h	mph
1st	7.0	4.3	6.9	4.3	6.9	4.3
2nd	12.5	7.8	12.0	7.5	12.0	7.5
3rd	22.0	13.7	19.3	12.0	19.3	12.0
4th	34.0	21.1	25.7	16.0	25.7	16.0
5th	—	—	39.5	24.5	39.5	24.5
Speeds Reverse:	km/h	mph	km/h	mph	km/h	mph
1st	7.0	4.3	6.9	4.3	6.9	4.3
2nd	12.5	7.8	12.0	7.5	12.0	7.5
3rd	22.0	13.7	25.7	16.0	25.7	16.0
Hydraulic Cycle Time, Rated Load in Bucket:	Seconds		Seconds		Seconds	
Raise (from Carry Position)	6.1		5.3		5.3	
Dump (at Maximum Raise)	1.2		1.5		1.4	
Lower (Empty, Float Down)	2.8		2.3		2.8	
Total	10.1		9.1		9.5	
Tread Width	2.15 m	7'0"	2140 mm	7'0"	2140 mm	7'0"
Width Over Tires	2.75 m	9'0"	2790 mm	9'2"	2790 mm	9'2"
Ground Clearance	460 mm	1'6"	385 mm	1'3"	385 mm	1'3"
Fuel Tank Capacity	290 L	77 U.S. gal	275 L	72.6 U.S. gal	275 L	72.6 U.S. gal
Hydraulic Tank Capacity	120 L	32 U.S. gal	125 L	33 U.S. gal	125 L	33 U.S. gal
Hydraulic System Capacity (includes tank)	190 L	50 U.S. gal	—	—	—	—

\*Meets Tier 3, Stage IIIA, Japan 2006 (Tier 3) equivalent emission standards.

**NOTE:** Net Engine Power is provided according to SAE J1349 and ISO 9249. Gross Engine Power is provided according to SAE J1995 for all models except for the 950 GC, which is ISO 14396. Machines may only be available in certain regions. Contact your local Cat dealer for product availability.



<b>MODEL</b>	<b>962M</b>		<b>962L</b>		<b>966L/966M</b>	
Emission Standards	<b>Tier 3 equivalent*</b>		<b>Tier 3 equivalent*</b>		<b>Tier 2 equivalent or Tier 3 equivalent**</b>	
Maximum Engine: Net	185 kW	<b>248 hp</b>	185 kW	<b>248 hp</b>	207 kW	<b>278 hp</b>
Gross	196 kW	<b>262 hp</b>	196 kW	<b>262 hp</b>	230 kW	<b>308 hp</b>
Engine Model	<b>C7.1 ACERT</b>		<b>C7.1 ACERT</b>		<b>C9.3 ACERT</b>	
Maximum Net Power Engine RPM	<b>2000</b>		<b>2000</b>		<b>1700</b>	
Bore	105 mm	<b>4.1"</b>	105 mm	<b>4.1"</b>	115 mm	<b>4.53"</b>
Stroke	135 mm	<b>5.3"</b>	135 mm	<b>5.3"</b>	149 mm	<b>5.87"</b>
No. Cylinders	<b>6</b>		<b>6</b>		<b>6</b>	
Displacement	7.01 L	<b>427.8 in<sup>3</sup></b>	7.01 L	<b>427.8 in<sup>3</sup></b>	9.3 L	<b>568 in<sup>3</sup></b>
Speeds Forward:	<b>km/h</b>	<b>mph</b>	<b>km/h</b>	<b>mph</b>	<b>km/h</b>	<b>mph</b>
1st	6.9	<b>4.3</b>	6.9	<b>4.3</b>	6.5	<b>4.0</b>
2nd	12.0	<b>7.5</b>	12.0	<b>7.5</b>	13.0	<b>8.1</b>
3rd	19.3	<b>12.0</b>	19.3	<b>12.0</b>	23.5	<b>14.6</b>
4th	25.7	<b>16.0</b>	25.7	<b>16.0</b>	39.5	<b>24.5</b>
5th	39.5	<b>24.5</b>	39.5	<b>24.5</b>	—	
Speeds Reverse:	<b>km/h</b>	<b>mph</b>	<b>km/h</b>	<b>mph</b>	<b>km/h</b>	<b>mph</b>
1st	6.9	<b>4.3</b>	6.9	<b>4.3</b>	7.1	<b>4.4</b>
2nd	12.0	<b>7.5</b>	12.0	<b>7.5</b>	14.4	<b>8.9</b>
3rd	25.7	<b>16.0</b>	25.7	<b>16.0</b>	25.9	<b>16.1</b>
4th	—		—		39.0	<b>24.2</b>
Hydraulic Cycle Time, Rated Load in Bucket:	<b>Seconds</b>		<b>Seconds</b>		<b>Seconds</b>	
Raise (from Carry Position)	<b>5.4</b>		<b>5.3</b>		<b>5.5</b>	
Dump (at Maximum Raise)	<b>1.5</b>		<b>1.4</b>		<b>1.4</b>	
Lower (Empty, Float Down)	<b>2.7</b>		<b>2.8</b>		<b>2.6</b>	
Total	<b>9.6</b>		<b>9.5</b>		<b>9.5</b>	
Tread Width	2140 mm	<b>7'0"</b>	2140 mm	<b>7'0"</b>	2230 mm	<b>7'4"</b>
Width Over Tires	2790 mm	<b>9'2"</b>	2790 mm	<b>9'2"</b>	2991 mm	<b>9'10"</b>
Ground Clearance	385 mm	<b>1'3"</b>	385 mm	<b>1'3"</b>	476 mm	<b>1'7"</b>
Fuel Tank Capacity	275 L	<b>72.6 U.S. gal</b>	275 L	<b>72.6 U.S. gal</b>	303 L	<b>80.0 U.S. gal</b>
Hydraulic Tank Capacity	125 L	<b>33 U.S. gal</b>	125 L	<b>33 U.S. gal</b>	125 L	<b>33.0 U.S. gal</b>

\*Meets Tier 3, Stage IIIA, Japan 2006 (Tier 3) equivalent emission standards.

\*\*Meets Tier 2/Stage II/Japan 2001 (Tier 2) equivalent OR Tier 3/Stage IIIA/Japan 2006 (Tier 3) equivalent emission standards.

**NOTE:** Net Engine Power is provided according to SAE J1349 and ISO 9249. Gross Engine Power is provided according to SAE J1995. Machines may only be available in certain regions. Contact your local Cat dealer for product availability.

MODEL	972L/972M		980L/980M		982M	
Emission Standards	Tier 2 equivalent or Tier 3 equivalent*		Tier 2 equivalent or Tier 3 equivalent*		Tier 2 equivalent or Tier 3 equivalent*	
Maximum Engine: Net	222 kW	<b>298 hp</b>	278 kW	<b>373 hp</b>	278 kW	<b>373 hp</b>
Gross	246 kW	<b>330 hp</b>	307 kW	<b>412 hp</b>	307 kW	<b>412 hp</b>
Engine Model	<b>C9.3 ACERT</b>		<b>C13 ACERT</b>		<b>C13 ACERT</b>	
Maximum Net Power Engine RPM	<b>1800</b>		<b>1800</b>		<b>1800</b>	
Bore	115 mm	<b>4.53"</b>	130 mm	<b>5.1"</b>	130 mm	<b>5.1"</b>
Stroke	149 mm	<b>5.87"</b>	157 mm	<b>6.2"</b>	157 mm	<b>6.2"</b>
No. Cylinders	<b>6</b>		<b>6</b>		<b>6</b>	
Displacement	9.3 L	<b>568 in<sup>3</sup></b>	12.5 L	<b>762.8 in<sup>3</sup></b>	12.5 L	<b>762.8 in<sup>3</sup></b>
Speeds Forward:	<b>km/h</b>	<b>mph</b>	<b>km/h</b>	<b>mph</b>	<b>km/h</b>	<b>mph</b>
1st	6.7	<b>4.2</b>	6.9	<b>4.3</b>	6.9	<b>4.3</b>
2nd	13.1	<b>8.1</b>	13.3	<b>8.3</b>	13.3	<b>8.3</b>
3rd	23.2	<b>14.4</b>	23.5	<b>14.6</b>	23.5	<b>14.6</b>
4th	39.5	<b>24.5</b>	39.5	<b>24.5</b>	39.5	<b>24.5</b>
Speeds Reverse:	<b>km/h</b>	<b>mph</b>	<b>km/h</b>	<b>mph</b>	<b>km/h</b>	<b>mph</b>
1st	7.6	<b>4.7</b>	7.8	<b>4.8</b>	7.8	<b>4.8</b>
2nd	15.0	<b>8.9</b>	15.2	<b>9.4</b>	15.2	<b>9.4</b>
3rd	26.5	<b>16.5</b>	26.9	<b>16.7</b>	26.9	<b>16.7</b>
4th	39.5	<b>24.5</b>	39.5	<b>24.5</b>	39.5	<b>24.5</b>
Hydraulic Cycle Time, Rated Load in Bucket:	<b>Seconds</b>		<b>Seconds</b>		<b>Seconds</b>	
Raise (from Carry Position)	<b>5.5</b>		<b>5.3</b>		<b>5.3</b>	
Dump (at Maximum Raise)	<b>1.5</b>		<b>1.7</b>		<b>1.7</b>	
Lower (Empty, Float Down)	<b>3.1</b>		<b>3.1</b>		<b>3.1</b>	
Total	<b>10.1</b>		<b>10.1</b>		<b>10.1</b>	
Tread Width	2230 mm	<b>7'4"</b>	2440 mm	<b>8'0"</b>	2440 mm	<b>8'0"</b>
Width Over Tires	2991 mm	<b>9'10"</b>	3265 mm	<b>10'9"</b>	3265 mm	<b>10'9"</b>
Ground Clearance	476 mm	<b>1'7"</b>	453 mm	<b>1'6"</b>	453 mm	<b>1'6"</b>
Fuel Tank Capacity	303 L	<b>80.0 U.S. gal</b>	426 L	<b>112.5 U.S. gal</b>	426 L	<b>112.5 U.S. gal</b>
Hydraulic Tank Capacity	125 L	<b>33.0 U.S. gal</b>	180 L	<b>48 U.S. gal</b>	180 L	<b>48 U.S. gal</b>

\*Meets Tier 2/Stage II/Japan 2001 (Tier 2) equivalent OR Tier 3/Stage IIIA/Japan 2006 (Tier 3) equivalent emission standards.

**NOTE:** Net Engine Power is provided according to SAE J1349 and ISO 9249. Gross Engine Power is provided according to SAE J1995. Machines may only be available in certain regions. Contact your local Cat dealer for product availability.

<b>MODEL</b>	<b>950H</b>		<b>962H</b>		<b>966H</b>	
Emission Standards	<b>Tier 3 equivalent*</b>		<b>Tier 3 equivalent*</b>		<b>Tier 3 equivalent*</b>	
Maximum Engine: Net	147 kW	<b>197 hp</b>	156 kW	<b>209 hp</b>	195 kW	<b>262 hp</b>
Gross	162 kW	<b>217 hp</b>	172 kW	<b>231 hp</b>	211 kW	<b>283 hp</b>
Engine Model	<b>C7 ACERT</b>		<b>C7 ACERT</b>		<b>C11 ACERT</b>	
Maximum Net Power Engine RPM	<b>1800</b>		<b>1800</b>		<b>1800</b>	
Bore	110 mm	<b>4.3"</b>	110 mm	<b>4.3"</b>	130 mm	<b>5.1"</b>
Stroke	127 mm	<b>5"</b>	127 mm	<b>5"</b>	140 mm	<b>5.5"</b>
No. Cylinders	<b>6</b>		<b>6</b>		<b>6</b>	
Displacement	7.2 L	<b>439 in<sup>3</sup></b>	7.2 L	<b>439 in<sup>3</sup></b>	11.1 L	<b>677 in<sup>3</sup></b>
Speeds Forward:	<b>km/h</b>	<b>mph</b>	<b>km/h</b>	<b>mph</b>	<b>km/h</b>	<b>mph</b>
1st	6.9	<b>4.3</b>	7.0	<b>4.4</b>	6.7	<b>4.2</b>
2nd	12.7	<b>7.9</b>	13.0	<b>8.1</b>	12.6	<b>7.8</b>
3rd	22.3	<b>13.9</b>	22.6	<b>14.0</b>	22.1	<b>13.7</b>
4th	37.0	<b>23.0</b>	38.0	<b>23.6</b>	37.4	<b>23.2</b>
Speeds Reverse:	<b>km/h</b>	<b>mph</b>	<b>km/h</b>	<b>mph</b>	<b>km/h</b>	<b>mph</b>
1st	7.6	<b>4.7</b>	7.6	<b>4.7</b>	7.4	<b>4.6</b>
2nd	13.9	<b>8.6</b>	13.9	<b>8.6</b>	13.9	<b>8.6</b>
3rd	24.5	<b>15.2</b>	24.5	<b>15.2</b>	24.3	<b>15.1</b>
4th	40.0	<b>24.9</b>	40.0	<b>24.9</b>	37.4	<b>23.2</b>
Hydraulic Cycle Time, Rated Load in Bucket:	<b>Seconds</b>		<b>Seconds</b>		<b>Seconds</b>	
Raise (from Carry Position)	<b>6.2</b>		<b>6.2</b>		<b>5.9</b>	
Dump (at Maximum Raise)	<b>2.0</b>		<b>2.0</b>		<b>1.6</b>	
Lower (Empty, Float Down)	<b>2.5</b>		<b>2.5</b>		<b>2.4</b>	
Total	<b>10.7</b>		<b>10.7</b>		<b>9.9</b>	
Tread Width	2.14 m	<b>7'0"</b>	2.14 m	<b>7'0"</b>	2.23 m	<b>7'4"</b>
Width Over Tires	2.79 m	<b>9'2"</b>	2.79 m	<b>9'2"</b>	3.06 m	<b>9'10"</b>
Ground Clearance	412 mm	<b>16"</b>	412 mm	<b>16"</b>	434 mm	<b>17"</b>
Fuel Tank Capacity	264 L	<b>70 U.S. gal</b>	264 L	<b>70 U.S. gal</b>	380 L	<b>100 U.S. gal</b>
Hydraulic Tank Capacity	110 L	<b>29 U.S. gal</b>	110 L	<b>29 U.S. gal</b>	110 L	<b>29 U.S. gal</b>
Hydraulic System Capacity (includes tank)	186 L	<b>48.4 U.S. gal</b>	186 L	<b>48.4 U.S. gal</b>	200 L	<b>52 U.S. gal</b>

\*Meets Tier 3, Stage IIIA, Japan 2006 (Tier 3) equivalent emission standards.

**NOTE:** Net Engine Power is provided according to SAE J1349 and ISO 9249. Gross Engine Power is provided according to SAE J1995. Machines may only be available in certain regions. Contact your local Cat dealer for product availability.

MODEL	972H		980H		986H		990K	
Emission Standards	Tier 3 equivalent*		Tier 3 equivalent*		Tier 2 equivalent or Tier 3 equivalent**		Tier 2 equivalent or Tier 4 Final***	
Maximum Engine: Net	214 kW	<b>287 hp</b>	260 kW	<b>349 hp</b>	305 kW	<b>409 hp</b>	521 kW	<b>699 hp</b>
Gross	232 kW	<b>311 hp</b>	293 kW	<b>392 hp</b>	335 kW	<b>449 hp</b>	561 kW	<b>752 hp</b>
Rated Payload†	—		—		10 tonnes	<b>11 tons</b>	15.9 tonnes	<b>17.5 tons</b>
Gross Rated Bucket Payload†	—		—		—		24 249 kg	<b>53,460 lb</b>
Engine Model	<b>C13 ACERT</b>		<b>C15 ACERT</b>		<b>C15 ACERT</b>		<b>C27 ACERT</b>	
Maximum Net Power Engine RPM	<b>1800</b>		<b>1800</b>		<b>1800</b>		<b>1800</b>	
Bore	130 mm	<b>5.1"</b>	137 mm	<b>5.4"</b>	137 mm	<b>5.4"</b>	137 mm	<b>5.4"</b>
Stroke	157 mm	<b>6.2"</b>	171 mm	<b>6.75"</b>	171 mm	<b>6.75"</b>	152 mm	<b>6"</b>
No. Cylinders	<b>6</b>		<b>6</b>		<b>6</b>		<b>12</b>	
Displacement	12.5 L	<b>763 in<sup>3</sup></b>	15.2 L	<b>928 in<sup>3</sup></b>	15.2 L	<b>928 in<sup>3</sup></b>	27.0 L	<b>1650 in<sup>3</sup></b>
Speeds Forward:	<b>km/h</b>	<b>mph</b>	<b>km/h</b>	<b>mph</b>	<b>km/h</b>	<b>mph</b>	<b>km/h</b>	<b>mph</b>
1st	7.2	<b>4.5</b>	6.6	<b>4.1</b>	7.3	<b>5</b>	7.3	<b>4.5</b>
2nd	12.6	<b>7.8</b>	11.8	<b>7.3</b>	12.7	<b>8</b>	13.3	<b>8.3</b>
3rd	21.4	<b>13.3</b>	20.7	<b>12.9</b>	22	<b>14</b>	22.9	<b>14.2</b>
4th	36.9	<b>22.9</b>	36.3	<b>22.6</b>	39	<b>24</b>	—	
Speeds Reverse:	<b>km/h</b>	<b>mph</b>	<b>km/h</b>	<b>mph</b>	<b>km/h</b>	<b>mph</b>	<b>km/h</b>	<b>mph</b>
1st	8.2	<b>5.1</b>	7.6	<b>4.7</b>	7.6	<b>5</b>	7.9	<b>4.9</b>
2nd	14.2	<b>8.8</b>	13.5	<b>8.4</b>	14.1	<b>9</b>	14.7	<b>9.1</b>
3rd	24.3	<b>15.1</b>	23.6	<b>14.7</b>	25	<b>12</b>	24.9	<b>15.5</b>
4th	38.8	<b>24.0</b>	41.5	<b>25.8</b>	—		—	
Hydraulic Cycle Time, Rated Load in Bucket:	<b>Seconds</b>		<b>Seconds</b>		<b>Seconds</b>		<b>Seconds</b>	
Raise††	<b>5.9</b>		<b>6.0</b>		<b>8.5</b>		<b>8.2</b>	
Dump (at Maximum Raise)	<b>2.1</b>		<b>2.1</b>		<b>3</b>		<b>2.9</b>	
Lower (Empty, Float Down)	<b>2.4</b>		<b>3.4</b>		<b>4.3</b>		<b>3.6</b>	
Total	<b>10.4</b>		<b>11.5</b>		<b>15.8</b>		<b>13.8</b>	
Tread Width	2.23 m	<b>7'4"</b>	2.43 m	<b>8'0"</b>	2.59 m	<b>8'6"</b>	3.1 m	<b>10'2"</b>
Width Over Tires	3.00 m	<b>9'10"</b>	3.18 m	<b>10'5"</b>	3.54 m	<b>11'7"</b>	4.1 m	<b>13'5"</b>
Ground Clearance	434 mm	<b>17"</b>	430 mm	<b>16.9"</b>	459 mm	<b>18"</b>	596 mm	<b>23.5"</b>
Fuel Tank Capacity	380 L	<b>100 U.S. gal</b>	453 L	<b>120 U.S. gal</b>	600 L	<b>159 U.S. gal</b>	1114 L	<b>294 U.S. gal</b>
Hydraulic Tank Capacity	110 L	<b>29 U.S. gal</b>	125 L	<b>33 U.S. gal</b>	130 L	<b>34 U.S. gal</b>	—	
Implement and Fan	—		—		—		261 L	<b>68.9 U.S. gal</b>
Steering and Braking	—		—		—		132 L	<b>34.9 U.S. gal</b>
Hydraulic System Capacity (includes tank)	200 L	<b>52 U.S. gal</b>	250 L	<b>66 U.S. gal</b>	330 L	<b>87 U.S. gal</b>	795 L	<b>210 U.S. gal</b>

\*Meets Tier 3, Stage IIIA, Japan 2006 (Tier 3) equivalent emission standards.

\*\*Meets Tier 2/Stage II/Japan 2001 (Tier 2) equivalent OR Tier 3/Stage IIIA/Japan 2006 (Tier 3) equivalent emission standards.

\*\*\*Meets Tier 2/Stage II/Japan 2001 (Tier 2) equivalent OR Tier 4 Final/Stage IV/Japan 2014 (Tier 4 Final) emission standards.

†Changes in bucket weight, including field installed wear iron, can impact rated payload. Consult your Cat dealer for assistance in selecting and configuring the proper bucket for the application. The Cat Large Wheel Loader Payload Policy is a guideline intended to maximize wheel loader structural and component life. The Cat Payload Policy is that the "Gross Bucket plus Payload Capacity" is the MAXIMUM weight that should be carried on the end of the Lift Arm/Boom.

††Raise is from carry position for the 972H and 980H.

NOTE: 972H and 980H Net Engine Power is provided according to SAE J1349 and ISO 9249. Gross Engine Power is provided according to SAE J1995. The 972H and 980H are not available in all regions. Contact your local Cat dealer for product availability.

MODEL	992K		993K		994K	
Maximum Engine: Net	607 kW	<b>814 hp</b>	764 kW	<b>1024 hp</b>	1297 kW	<b>1739 hp</b>
Gross	671 kW	<b>900 hp</b>	773 kW	<b>1036 hp</b>	1377 kW	<b>1847 hp</b>
Rated Payload:*						
STD	21.8 tonnes	<b>24 tons</b>	22.7 tonnes	<b>30 tons</b>	40.8 tonnes	<b>45 tons</b>
HL, EHL, SHL	19 tonnes	<b>21 tons</b>	24.9 tonnes	<b>27.5 tons</b>	38.1 tonnes	<b>42 tons</b>
Gross Rated Bucket Payload:*						
STD	33 687 kg	<b>74,265 lb</b>	42 912 kg	<b>94,603 lb</b>	64 791 kg	<b>142,838 lb</b>
HL	30 138 kg	<b>66,441 lb</b>	40 459 kg	<b>89,195 lb</b>	61 458 kg	<b>135,489 lb</b>
Engine Model	<b>C32 ACERT**</b>		<b>C32 ACERT**</b>		<b>3516E</b>	
Emission Level						
Rated Engine RPM	<b>1750</b>		<b>1900</b>		<b>1600</b>	
Bore	145 mm	<b>5.7"</b>	145 mm	<b>5.7"</b>	170 mm	<b>6.7"</b>
Stroke	162 mm	<b>6.4"</b>	162 mm	<b>6.4"</b>	215 mm	<b>8.5"</b>
No. Cylinders	<b>12</b>		<b>12</b>		<b>16</b>	
Displacement	32.1 L	<b>1959 in<sup>3</sup></b>	32.1 L	<b>1959 in<sup>3</sup></b>	78 L	<b>4766 in<sup>3</sup></b>
Speeds Forward:	<b>km/h</b>	<b>mph</b>	<b>km/h</b>	<b>mph</b>	<b>km/h</b>	<b>mph</b>
1st	7.1	<b>4.4</b>	6.8	<b>4.2</b>	7.4	<b>4.6</b>
2nd	12.2	<b>7.6</b>	11.9	<b>7.4</b>	12.9	<b>8.0</b>
3rd	20.6	<b>12.8</b>	20.5	<b>12.7</b>	24.0	<b>14.9</b>
Speeds Reverse:	<b>km/h</b>	<b>mph</b>	<b>km/h</b>	<b>mph</b>	<b>km/h</b>	<b>mph</b>
1st	7.4	<b>4.6</b>	7.5	<b>4.7</b>	8.1	<b>5.0</b>
2nd	13.0	<b>8.1</b>	13.1	<b>8.1</b>	14.1	<b>8.8</b>
3rd	22.4	<b>13.9</b>	22.5	<b>13.9</b>	24.0	<b>14.9</b>
Hydraulic Cycle Time, Rated Load in Bucket:	<b>Seconds</b>		<b>Seconds</b>		<b>Seconds</b>	
Raise	<b>9.4</b>		<b>9.2</b>		<b>12.6</b>	
Dump	<b>1.8</b>		<b>1.8</b>		<b>3.1</b>	
Lower (Empty, Float Down)	<b>3.7</b>		<b>3.1</b>		<b>4.2</b>	
Total	<b>14.9</b>		<b>14.1</b>		<b>19.9</b>	
Tread Width	3.3 m	<b>10'10"</b>	3.54 m	<b>11'6"</b>	4.3 m	<b>14'1"</b>
Width Over Tires	4.5 m	<b>14'9"</b>	4.93 m	<b>16'2"</b>	5.49 m	<b>18'10"</b>
Ground Clearance	682 mm	<b>26.8"</b>	721 mm	<b>2'5"</b>	898 mm	<b>33"</b>
Fuel Tank Capacity	1610 L	<b>425 U.S. gal</b>	2170 L	<b>573 U.S. gal</b>	3445 L	<b>910 U.S. gal</b>
Hydraulic Systems:						
Lift, Tilt	646 L	<b>171 U.S. gal</b>	755 L	<b>199 U.S. gal</b>	1022 L	<b>270 U.S. gal</b>
Tank Only	326 L	<b>86 U.S. gal</b>	553 L	<b>146 U.S. gal</b>	756 L	<b>200 U.S. gal</b>
Steering and Brakes	231 L	<b>61 U.S. gal</b>	227 L	<b>60 U.S. gal</b>	379 L	<b>100 U.S. gal</b>
Tank Only	159 L	<b>42 U.S. gal</b>	185 L	<b>48.9 U.S. gal</b>	340 L	<b>90 U.S. gal</b>

\*Changes in bucket weight, including field installed wear iron, can impact rated payload. Consult your Cat dealer for assistance in selecting and configuring the proper bucket for the application. The Cat Large Wheel Loader Payload Policy is a guideline intended to maximize wheel loader structural and component life. The Cat Payload Policy is that the "Gross Bucket plus Payload Capacity" is the MAXIMUM weight that should be carried on the end of the Lift Arm/Boom.

\*\*Products available to meet Tier 2/Stage II/Japan 2001 (Tier 2) equivalent OR Tier 4 Final/Stage IV/Japan 2014 (Tier 4 Final) emission standards.  
NOTE: The 994K meets Tier 1 equivalent emission standards.

Bucket Type	General Purpose	
Ground Engaging Type	Bolt-on Cutting Edges	
Rated capacity	m <sup>3</sup>	0.6
	yd <sup>3</sup>	<b>0.8</b>
Width: bucket	mm	1770
	in	<b>70</b>
Nominal material density, 100% fill factor	kg/m <sup>3</sup>	1540
	lb/yd <sup>3</sup>	<b>2545</b>
Clearance: full lift, 45° dump	mm	2290
	ft/in	<b>7'6"</b>
Reach: full lift, 45° dump	mm	875
	ft/in	<b>2'10"</b>
Reach: level arm, level bucket	mm	1515
	ft/in	<b>5'0"</b>
Dig depth	mm	200
	in	<b>8</b>
Length: overall	mm	4695
	ft/in	<b>15'5"</b>
Height: overall	mm	2510
	ft/in	<b>8'3"</b>
Turning radius, bucket at carry	mm	3940
	ft/in	<b>13'1"</b>
Tipping load — straight, ISO 14397-1*	kg	2470
	lb	<b>5445</b>
Tipping load — full turn, ISO 14397-1*	kg	2090
	lb	<b>4610</b>
Breakout force	kg	2345
	kN	23
	lbf	<b>5170</b>
Operating weight	kg	4280
	lb	<b>9435</b>

\*Full compliance to ISO 14397-1 (2007) Sections 1 thru 6, which requires 2% verification between calculation and testing.

**NOTE:** Operating specifications and dimensions shown are based on 903C2 equipped with enclosed ROPS cab with air conditioning, standard lift linkage, quick coupler, additional counterweight, 75 kg (165 lb) operator and general purpose bucket (GP) unless otherwise noted.

# Wheel Loaders Integrated Toolcarriers

## Performance Data

- 906K/M
- Vertical Coupler

Bucket Type		General Purpose			Multi-Purpose			Light Material
		Bare	Bolt-on Cutting Edges	Bolt-on Teeth	Bare	Bolt-on Cutting Edges	Bolt-on Teeth	Bolt-on Cutting Edges
Ground Engaging Type								
	Rated bucket capacity (\$)	m <sup>3</sup> yd <sup>3</sup>	0.9 <b>1.18</b>	0.9 <b>1.18</b>	0.9 <b>1.18</b>	0.75 <b>1.0</b>	0.75 <b>1.0</b>	0.75 <b>1.0</b>
Struck capacity (\$)								
		m <sup>3</sup> yd <sup>3</sup>	0.75 <b>1.0</b>	0.75 <b>1.0</b>	0.75 <b>1.0</b>	0.6 <b>0.8</b>	0.6 <b>0.8</b>	0.6 <b>0.8</b>
Bucket width								
		mm ft/in	1880 <b>6'2"</b>	1890 <b>6'2"</b>	1880 <b>6'2"</b>	1880 <b>6'2"</b>	1890 <b>6'2"</b>	1880 <b>6'2"</b>
Dump clearance at full lift and 45° discharge (\$)								
		mm ft/in	2393 <b>7'8"</b>	2359 <b>7'8"</b>	2393 <b>7'8"</b>	2468 <b>8'1"</b>	2434 <b>8'0"</b>	2468 <b>8'1"</b>
Reach at full lift and 45° discharge (\$)								
		mm ft/in	809 <b>2'8"</b>	820 <b>2'8"</b>	809 <b>2'8"</b>	758 <b>2'6"</b>	770 <b>2'6"</b>	758 <b>2'6"</b>
Reach at 45° discharge and 2130 mm (7'0") clearance (\$)								
		mm ft/in	1035 <b>2'8"</b>	1050 <b>2'8"</b>	1035 <b>2'8"</b>	970 <b>2'8"</b>	986 <b>2'8"</b>	970 <b>2'8"</b>
Reach with lift arms horizontal and bucket level								
		mm ft/in	2000 <b>6'7"</b>	2033 <b>6'8"</b>	2000 <b>6'7"</b>	1919 <b>6'4"</b>	1952 <b>6'5"</b>	1919 <b>6'4"</b>
Digging depth (\$)								
		mm in	91 <b>3.6</b>	107 <b>4.2</b>	91 <b>3.6</b>	85 <b>3.3</b>	101 <b>4.0</b>	85 <b>3.3</b>
Overall length								
		mm ft/in	5586 <b>18'4"</b>	5620 <b>18'4"</b>	5586 <b>18'4"</b>	5497 <b>18'0"</b>	5530 <b>18'2"</b>	5497 <b>18'0"</b>
Overall height with bucket at full raise (\$)								
		mm ft/in	4192 <b>13'9"</b>	4192 <b>13'9"</b>	4192 <b>13'9"</b>	4176 <b>13'8"</b>	4176 <b>13'8"</b>	4176 <b>13'8"</b>
Loader clearance circle with bucket in carry position								
		mm ft/in	8890 <b>29'2"</b>	8928 <b>29'3"</b>	8890 <b>29'2"</b>	8832 <b>29'0"</b>	8868 <b>29'1"</b>	8832 <b>29'0"</b>
Static tipping load, straight* (\$)								
		kg lb	4128 <b>9098</b>	3932 <b>8666</b>	4021 <b>8862</b>	4184 <b>9221</b>	4009 <b>8835</b>	4086 <b>9005</b>
Static tipping load, full turn* (\$)								
		kg lb	3363 <b>7412</b>	3204 <b>7061</b>	3276 <b>7220</b>	3409 <b>7513</b>	3266 <b>7198</b>	3329 <b>7337</b>
Breakout force (\$)								
		kN lbf	43 <b>9666</b>	41 <b>9216</b>	38 <b>8541</b>	47 <b>10,564</b>	45 <b>10,115</b>	42 <b>9440</b>
Operating weight*								
		kg lb	5560 <b>12,254</b>	5595 <b>12,331</b>	5573 <b>12,282</b>	5701 <b>12,565</b>	5765 <b>12,706</b>	5742 <b>12,655</b>

\*Static tipping load and operating weights shown are with implements, ROPS cab, 12.5-20 tires, full fuel tank and 80 kg (176 lb) operator.

**NOTE:** Specifications and ratings conform to all applicable standards recommended by the Society of Automotive Engineers (SAE). SAE Standards J732 JUN92 and J742 FEB85 govern loader rating, denoted in the text by (\$).

Performance Data  
 ● 906K/M  
 ● Horizontal Coupler

Wheel Loaders  
 Integrated Toolcarriers

Bucket Type	General Purpose			Multi-Purpose			Light Material	
		Bare	Bolt-on Cutting Edges	Bolt-on Teeth	Bare	Bolt-on Cutting Edges	Bolt-on Teeth	Bolt-on Cutting Edges
Ground Engaging Type								
	Rated bucket capacity (\$)	m <sup>3</sup> yd <sup>3</sup>	0.9 <b>1.18</b>	0.9 <b>1.18</b>	0.9 <b>1.18</b>	0.75 <b>0.98</b>	0.75 <b>0.98</b>	0.75 <b>0.98</b>
Struck capacity (\$)								
		m <sup>3</sup> yd <sup>3</sup>	0.75 <b>0.98</b>	0.75 <b>0.98</b>	0.75 <b>0.98</b>	0.6 <b>0.78</b>	0.6 <b>0.78</b>	0.6 <b>0.78</b>
Bucket width								
		mm ft/in	1880 <b>6'2"</b>	1890 <b>6'2"</b>	1880 <b>6'2"</b>	1880 <b>6'2"</b>	1890 <b>6'2"</b>	1880 <b>6'2"</b>
Dump clearance at full lift and 45° discharge (\$)								
		mm ft/in	2513 <b>8'3"</b>	2478 <b>8'2"</b>	2437 <b>8'0"</b>	2500 <b>8'2"</b>	2465 <b>8'1"</b>	2428 <b>8'0"</b>
Reach at full lift and 45° discharge (\$)								
		mm ft/in	714 <b>2'4"</b>	725 <b>2'5"</b>	785 <b>2'7"</b>	704 <b>2'4"</b>	715 <b>2'4"</b>	775 <b>2'7"</b>
Reach at 45° discharge and 2130 mm (7'0") clearance (\$)								
		mm ft/in	914 <b>3'0"</b>	928 <b>3'1"</b>	1005 <b>3'4"</b>	901 <b>2'11"</b>	915 <b>3'0"</b>	992 <b>3'3"</b>
Reach with lift arms horizontal and bucket level								
		mm ft/in	1851 <b>6'1"</b>	1883 <b>6'2"</b>	1953 <b>6'5"</b>	1858 <b>6'1"</b>	1891 <b>6'2"</b>	1960 <b>6'5"</b>
Digging depth (\$)								
		mm in	79 <b>3.0</b>	95 <b>4.0</b>	79 <b>3.0</b>	90 <b>4.0</b>	106 <b>4.0</b>	90 <b>4.0</b>
Overall length								
		mm ft/in	5436 <b>17'10"</b>	5469 <b>17'11"</b>	5538 <b>18'2"</b>	5436 <b>17'10"</b>	5436 <b>17'10"</b>	5538 <b>18'2"</b>
Overall height with bucket at full raise (\$)								
		mm ft/in	4077 <b>13'5"</b>	4077 <b>13'5"</b>	4077 <b>13'5"</b>	4134 <b>13'7"</b>	4134 <b>13'7"</b>	4134 <b>13'7"</b>
Loader clearance circle with bucket in carry position								
		mm ft/in	8802 <b>28'11"</b>	8840 <b>29'0"</b>	8784 <b>28'10"</b>	8812 <b>28'11"</b>	8848 <b>29'0"</b>	8792 <b>28'10"</b>
Static tipping load, straight* (\$)								
		kg lb	4380 <b>9653</b>	4219 <b>9298</b>	4317 <b>9514</b>	4288 <b>9450</b>	4110 <b>9058</b>	4188 <b>9230</b>
Static tipping load, full turn* (\$)								
		kg lb	3568 <b>7863</b>	3437 <b>7575</b>	3517 <b>7751</b>	3493 <b>7698</b>	3348 <b>7378</b>	3412 <b>7520</b>
Breakout force (\$)								
		kN lbf	51 <b>11,463</b>	49 <b>11,014</b>	45 <b>10,115</b>	52 <b>11,688</b>	49 <b>11,014</b>	45 <b>10,115</b>
Operating weight*								
		kg lb	5545 <b>12,221</b>	5581 <b>12,300</b>	5559 <b>12,252</b>	5707 <b>12,578</b>	5772 <b>12,721</b>	5750 <b>12,673</b>

\*Static tipping load and operating weights shown are with implements, ROPS cab, 12.5-20 tires, full fuel tank and 80 kg (176 lb) operator.  
 NOTE: Specifications and ratings conform to all applicable standards recommended by the Society of Automotive Engineers (SAE). SAE Standards J732 JUN92 and J742 FEB85 govern loader rating, denoted in the text by (\$).



# Wheel Loaders Integrated Toolcarriers

## Performance Data

- 907K/M
- Vertical Coupler

Bucket Type		General Purpose			Multi-Purpose			Light Material
		Bare	Bolt-on Cutting Edges	Bolt-on Teeth	Bare	Bolt-on Cutting Edges	Bolt-on Teeth	Bolt-on Cutting Edges
<b>Ground Engaging Type</b>								
Rated bucket capacity (\$)	m <sup>3</sup>	1.0	1.0	1.0	0.75	0.75	0.75	1.2
	yd <sup>3</sup>	<b>1.31</b>	<b>1.31</b>	<b>1.31</b>	<b>1.0</b>	<b>1.0</b>	<b>1.0</b>	<b>1.56</b>
Struck capacity (\$)	m <sup>3</sup>	0.8	0.8	0.8	0.6	0.6	0.6	1.0
	yd <sup>3</sup>	<b>1.05</b>	<b>1.05</b>	<b>1.05</b>	<b>0.8</b>	<b>0.8</b>	<b>0.8</b>	<b>1.31</b>
Bucket width	mm	2035	2045	2035	1880	1890	1880	2080
	ft/in	<b>6'8"</b>	<b>6'9"</b>	<b>6'8"</b>	<b>6'2"</b>	<b>6'2"</b>	<b>6'2"</b>	<b>6'10"</b>
Dump clearance at full lift and 45° discharge (\$)	mm	2393	2359	2321	2468	2434	2397	2395
	ft/in	<b>7'10"</b>	<b>7'9"</b>	<b>7'7"</b>	<b>8'1"</b>	<b>8'0"</b>	<b>7'10"</b>	<b>7'10"</b>
Reach at full lift and 45° discharge (\$)	mm	809	820	880	758	770	830	803
	ft/in	<b>2'8"</b>	<b>2'8"</b>	<b>2'11"</b>	<b>2'6"</b>	<b>2'6"</b>	<b>2'9"</b>	<b>2'8"</b>
Reach at 45° discharge and 2130 mm (7'0") clearance (\$)	mm	1035	1050	1100	970	986	1036	1027
	ft/in	<b>3'5"</b>	<b>3'5"</b>	<b>3'7"</b>	<b>3'2"</b>	<b>3'3"</b>	<b>3'5"</b>	<b>3'4"</b>
Reach with lift arms horizontal and bucket level	mm	2000	2033	2102	1919	1952	2021	2144
	ft/in	<b>6'7"</b>	<b>6'8"</b>	<b>6'11"</b>	<b>6'4"</b>	<b>6'5"</b>	<b>6'8"</b>	<b>7'0"</b>
Digging depth (\$)	mm	91	107	91	85	101	85	104
	in	<b>3.6</b>	<b>4.2</b>	<b>3.6</b>	<b>3.4</b>	<b>4.0</b>	<b>3.4</b>	<b>4.1</b>
Overall length	mm	5586	5620	5690	5497	5530	5599	5730
	ft/in	<b>18'4"</b>	<b>18'5"</b>	<b>18'8"</b>	<b>18'0"</b>	<b>18'2"</b>	<b>18'4"</b>	<b>18'10"</b>
Overall height with bucket at full raise (\$)	mm	4192	4192	4192	4176	4176	4176	4257
	ft/in	<b>13'9"</b>	<b>13'9"</b>	<b>13'9"</b>	<b>13'8"</b>	<b>13'8"</b>	<b>13'8"</b>	<b>14'0"</b>
Loader clearance circle with bucket in carry position	mm	9030	9068	9016	8832	8868	8812	9132
	ft/in	<b>29'8"</b>	<b>29'9"</b>	<b>29'7"</b>	<b>29'0"</b>	<b>29'1"</b>	<b>28'11"</b>	<b>30'0"</b>
Static tipping load, straight* (\$)	kg	4268	4110	4195	4391	4211	4290	3984
	lb	<b>9409</b>	<b>9058</b>	<b>9245</b>	<b>9677</b>	<b>9281</b>	<b>9455</b>	<b>8780</b>
Static tipping load, full turn* (\$)	kg	3477	3349	3418	3577	3430	3495	3245
	lb	<b>7665</b>	<b>7381</b>	<b>7533</b>	<b>7883</b>	<b>7559</b>	<b>7702</b>	<b>7151</b>
Breakout force (\$)	kN	43	41	38	47	45	42	38
	lbf	<b>9666</b>	<b>9216</b>	<b>8541</b>	<b>10,564</b>	<b>10,115</b>	<b>9440</b>	<b>8541</b>
Operating weight*	kg	5745	5783	5762	5871	5934	5912	5833
	lb	<b>12,661</b>	<b>12,745</b>	<b>12,699</b>	<b>12,939</b>	<b>13,078</b>	<b>13,030</b>	<b>12,855</b>

\*Static tipping load and operating weights shown are with implements, ROPS cab, 12.5-20 tires, full fuel tank and 80 kg (176 lb) operator.

**NOTE:** Specifications and ratings conform to all applicable standards recommended by the Society of Automotive Engineers (SAE). SAE Standards J732 JUN92 and J742 FEB85 govern loader rating, denoted in the text by (\$).

Performance Data  
 ● 907K/M  
 ● Horizontal Coupler

Wheel Loaders  
 Integrated Toolcarriers

Bucket Type		General Purpose			Multi-Purpose			Light Material
		Bare	Bolt-on Cutting Edges	Bolt-on Teeth	Bare	Bolt-on Cutting Edges	Bolt-on Teeth	Bolt-on Cutting Edges
Ground Engaging Type								
	Rated bucket capacity (\$)	m <sup>3</sup> yd <sup>3</sup>	1.0 <b>1.31</b>	1.0 <b>1.31</b>	1.0 <b>1.31</b>	0.75 <b>0.98</b>	0.75 <b>0.98</b>	0.75 <b>0.98</b>
Struck capacity (\$)	m <sup>3</sup> yd <sup>3</sup>	0.75 <b>0.98</b>	0.75 <b>0.98</b>	0.75 <b>0.98</b>	0.6 <b>0.78</b>	0.6 <b>0.78</b>	0.6 <b>0.78</b>	1.0 <b>1.31</b>
	Bucket width	mm ft/in	2035 <b>6'8"</b>	2045 <b>6'9"</b>	2035 <b>6'8"</b>	1880 <b>6'2"</b>	1890 <b>6'2"</b>	1880 <b>6'2"</b>
Dump clearance at full lift and 45° discharge (\$)	mm ft/in	2513 <b>8'3"</b>	2478 <b>8'2"</b>	2437 <b>8'0"</b>	2500 <b>8'2"</b>	2465 <b>8'1"</b>	2428 <b>8'0"</b>	2429 <b>8'0"</b>
	Reach at full lift and 45° discharge (\$)	mm ft/in	714 <b>2'4"</b>	725 <b>2'5"</b>	785 <b>2'7"</b>	704 <b>2'4"</b>	715 <b>2'4"</b>	775 <b>2'7"</b>
Reach at 45° discharge and 2130 mm (7'0") clearance (\$)	mm ft/in	914 <b>3'0"</b>	928 <b>3'1"</b>	1005 <b>3'4"</b>	900 <b>2'11"</b>	915 <b>3'0"</b>	992 <b>3'3"</b>	1014 <b>3'4"</b>
	Reach with lift arms horizontal and bucket level	mm ft/in	1851 <b>6'1"</b>	1883 <b>6'2"</b>	1953 <b>6'5"</b>	1858 <b>6'1"</b>	1891 <b>6'2"</b>	1960 <b>6'5"</b>
Digging depth (\$)	mm in	79 <b>3.1</b>	95 <b>3.7</b>	79 <b>3.1</b>	90 <b>3.5</b>	106 <b>4.2</b>	90 <b>3.5</b>	83 <b>3.0</b>
	Overall length	mm ft/in	5436 <b>17'10"</b>	5469 <b>17'11"</b>	5538 <b>18'2"</b>	5436 <b>17'10"</b>	5469 <b>17'11"</b>	5538 <b>18'2"</b>
Overall height with bucket at full raise (\$)	mm ft/in	4077 <b>13'5"</b>	4077 <b>13'5"</b>	4077 <b>13'5"</b>	4134 <b>13'7"</b>	4134 <b>13'7"</b>	4134 <b>13'7"</b>	4141 <b>13'7"</b>
	Loader clearance circle with bucket in carry position	mm ft/in	8946 <b>29'4"</b>	8978 <b>29'5"</b>	8784 <b>28'10"</b>	8812 <b>28'11"</b>	8848 <b>29'0"</b>	8792 <b>28'10"</b>
Static tipping load, straight* (\$)	kg lb	4584 <b>10,103</b>	4408 <b>9715</b>	4503 <b>9924</b>	4499 <b>9915</b>	4316 <b>9512</b>	4397 <b>9690</b>	4267 <b>9404</b>
	Static tipping load, full turn* (\$)	kg lb	3734 <b>8229</b>	3591 <b>7914</b>	3668 <b>8084</b>	3665 <b>8077</b>	3516 <b>7749</b>	3582 <b>7894</b>
Breakout force (\$)	kN lbf	52 <b>11,689</b>	49 <b>11,014</b>	45 <b>10,115</b>	52 <b>11,688</b>	49 <b>11,014</b>	45 <b>10,115</b>	43 <b>9665</b>
	Operating weight*	kg lb	5730 <b>12,628</b>	5769 <b>12,714</b>	5748 <b>12,668</b>	5877 <b>12,952</b>	5942 <b>13,096</b>	5920 <b>13,047</b>

\*Static tipping load and operating weights shown are with implements, ROPS cab, 12.5-20 tires, full fuel tank and 80 kg (176 lb) operator.  
 NOTE: Specifications and ratings conform to all applicable standards recommended by the Society of Automotive Engineers (SAE). SAE Standards J732 JUN92 and J742 FEB85 govern loader rating, denoted in the text by (\$).

# Wheel Loaders Integrated Toolcarriers

## Performance Data

- 908K/M
- Vertical Coupler

Bucket Type		General Purpose			Multi-Purpose			Light Material
		Bare	Bolt-on Cutting Edges	Bolt-on Teeth	Bare	Bolt-on Cutting Edges	Bolt-on Teeth	Bolt-on Cutting Edges
Ground Engaging Type								
	Rated bucket capacity (\$)	m <sup>3</sup> 1.1	1.1	1.1	0.9	0.9	0.9	1.5
		yd <sup>3</sup> <b>1.44</b>	<b>1.44</b>	<b>1.44</b>	<b>1.18</b>	<b>1.18</b>	<b>1.18</b>	<b>1.96</b>
Struck capacity (\$)		m <sup>3</sup> 0.9	0.9	0.9	0.75	0.75	0.75	1.25
		yd <sup>3</sup> <b>1.18</b>	<b>1.18</b>	<b>1.18</b>	<b>1.0</b>	<b>1.0</b>	<b>1.0</b>	<b>1.64</b>
Bucket width		mm 2060	2080	2060	2060	2080	2060	2080
		ft/in <b>6'9"</b>	<b>6'10"</b>	<b>6'9"</b>	<b>6'9"</b>	<b>6'10"</b>	<b>6'9"</b>	<b>6'10"</b>
Dump clearance at full lift and 45° discharge (\$)		mm 2539	2505	2467	2627	2593	2556	2346
		ft/in <b>8'4"</b>	<b>8'3"</b>	<b>8'1"</b>	<b>8'7"</b>	<b>8'6"</b>	<b>8'5"</b>	<b>7'8"</b>
Reach at full lift and 45° discharge (\$)		mm 854	866	926	788	800	861	1025
		ft/in <b>2'10"</b>	<b>2'10"</b>	<b>3'0"</b>	<b>2'7"</b>	<b>2'7"</b>	<b>2'10"</b>	<b>3'4"</b>
Reach at 45° discharge and 2130 mm (7'0") clearance (\$)		mm 1093	1109	1169	1010	1024	1085	1312
		ft/in <b>3'7"</b>	<b>3'7"</b>	<b>3'10"</b>	<b>3'4"</b>	<b>3'4"</b>	<b>3'7"</b>	<b>4'4"</b>
Reach with lift arms horizontal and bucket level		mm 2149	2181	2251	2039	2072	2141	2405
		ft/in <b>7'1"</b>	<b>7'2"</b>	<b>7'5"</b>	<b>6'8"</b>	<b>6'10"</b>	<b>7'0"</b>	<b>7'11"</b>
Digging depth (\$)		mm 93	109	93	101	117	101	109
		in <b>3.7</b>	<b>4.3</b>	<b>3.7</b>	<b>4.0</b>	<b>4.6</b>	<b>4.0</b>	<b>4.3</b>
Overall length		mm 5747	5780	5849	5643	5670	5740	6004
		ft/in <b>18'10"</b>	<b>19'0"</b>	<b>19'2"</b>	<b>18'6"</b>	<b>18'7"</b>	<b>18'10"</b>	<b>19'8"</b>
Overall height with bucket at full raise (\$)		mm 4415	4415	4415	4392	4392	4392	4547
		ft/in <b>14'6"</b>	<b>14'6"</b>	<b>14'6"</b>	<b>14'5"</b>	<b>14'5"</b>	<b>14'5"</b>	<b>14'11"</b>
Loader clearance circle with bucket in carry position		mm 9118	9158	9110	9042	9080	9030	9298
		ft/in <b>29'11"</b>	<b>30'1"</b>	<b>29'11"</b>	<b>29'8"</b>	<b>29'9"</b>	<b>29'8"</b>	<b>30'6"</b>
Static tipping load, straight* (\$)		kg 4580	4427	4526	4721	4530	4618	4256
		lb <b>10,094</b>	<b>9757</b>	<b>9975</b>	<b>10,405</b>	<b>9984</b>	<b>10,178</b>	<b>9380</b>
Static tipping load, full turn* (\$)		kg 3731	3606	3687	3846	3690	3762	3467
		lb <b>8223</b>	<b>7947</b>	<b>8126</b>	<b>8476</b>	<b>8132</b>	<b>8291</b>	<b>7641</b>
Breakout force (\$)		kN 51	46	43	54	52	48	38
		lbf <b>11,464</b>	<b>10,339</b>	<b>9665</b>	<b>12,138</b>	<b>11,688</b>	<b>10,789</b>	<b>8541</b>
Operating weight*		kg 6325	6364	6338	6469	6534	6508	6435
		lb <b>13,940</b>	<b>14,026</b>	<b>13,968</b>	<b>14,262</b>	<b>14,400</b>	<b>14,343</b>	<b>14,182</b>

\*Static tipping load and operating weights shown are with implements, ROPS cab, 12.5-20 tires, full fuel tank and 80 kg (176 lb) operator.

**NOTE:** Specifications and ratings conform to all applicable standards recommended by the Society of Automotive Engineers (SAE). SAE Standards J732 JUN92 and J742 FEB85 govern loader rating, denoted in the text by (\$).

Performance Data  
 ● 908K/M  
 ● Horizontal Coupler

Wheel Loaders  
 Integrated Toolcarriers

Bucket Type	General Purpose			Multi-Purpose			Light Material	
		Bare	Bolt-on Cutting Edges	Bolt-on Teeth	Bare	Bolt-on Cutting Edges	Bolt-on Teeth	Bolt-on Cutting Edges
<b>Ground Engaging Type</b>								
Rated bucket capacity (\$)	m <sup>3</sup>	1.1	1.1	1.1	0.9	0.95	0.9	1.5
	yd <sup>3</sup>	<b>1.44</b>	<b>1.44</b>	<b>1.44</b>	<b>1.18</b>	<b>1.24</b>	<b>1.18</b>	<b>1.96</b>
Struck capacity (\$)	m <sup>3</sup>	0.9	0.9	0.9	0.75	0.75	0.75	1.25
	yd <sup>3</sup>	<b>1.18</b>	<b>1.18</b>	<b>1.18</b>	<b>0.98</b>	<b>0.98</b>	<b>0.98</b>	<b>1.64</b>
Bucket width	mm	2060	2080	2060	2060	2080	2060	2080
	ft/in	<b>6'9"</b>	<b>6'10"</b>	<b>6'9"</b>	<b>6'9"</b>	<b>6'10"</b>	<b>6'9"</b>	<b>6'10"</b>
Dump clearance at full lift and 45° discharge (\$)	mm	2653	2620	2583	2665	2624	2586	2463
	ft/in	<b>8'8"</b>	<b>8'7"</b>	<b>8'6"</b>	<b>8'9"</b>	<b>8'7"</b>	<b>8'6"</b>	<b>8'1"</b>
Reach at full lift and 45° discharge (\$)	mm	757	770	830	737	748	811	931
	ft/in	<b>2'6"</b>	<b>2'6"</b>	<b>2'9"</b>	<b>2'5"</b>	<b>2'5"</b>	<b>2'8"</b>	<b>3'1"</b>
Reach at 45° discharge and 2130 mm (7'0") clearance (\$)	mm	969	986	1062	944	957	1038	1191
	ft/in	<b>3'2"</b>	<b>3'3"</b>	<b>3'6"</b>	<b>3'1"</b>	<b>3'2"</b>	<b>3'5"</b>	<b>3'11"</b>
Reach with lift arms horizontal and bucket level	mm	1999	2031	2101	1978	2010	2080	2256
	ft/in	<b>6'7"</b>	<b>6'8"</b>	<b>6'11"</b>	<b>6'6"</b>	<b>6'7"</b>	<b>6'10"</b>	<b>7'5"</b>
Digging depth (\$)	mm	85	101	85	94	110	94	101
	in	<b>3.3</b>	<b>4.0</b>	<b>3.3</b>	<b>3.7</b>	<b>4.3</b>	<b>3.7</b>	<b>4.0</b>
Overall length	mm	5598	5630	5699	5576	5609	5678	5854
	ft/in	<b>18'4"</b>	<b>18'6"</b>	<b>18'8"</b>	<b>18'4"</b>	<b>18'5"</b>	<b>18'8"</b>	<b>19'2"</b>
Overall height with bucket at full raise (\$)	mm	4304	4304	4304	4345	4345	4345	4437
	ft/in	<b>14'1"</b>	<b>14'1"</b>	<b>14'1"</b>	<b>14'3"</b>	<b>14'3"</b>	<b>14'3"</b>	<b>14'7"</b>
Loader clearance circle with bucket in carry position	mm	9022	9060	9008	9018	9056	9004	9192
	ft/in	<b>29'7"</b>	<b>29'9"</b>	<b>29'7"</b>	<b>29'7"</b>	<b>29'9"</b>	<b>29'6"</b>	<b>30'2"</b>
Static tipping load, straight* (\$)	kg	4888	4719	4828	4825	4865	4959	4527
	lb	<b>10,773</b>	<b>10,400</b>	<b>10,640</b>	<b>10,634</b>	<b>10,725</b>	<b>10,933</b>	<b>9977</b>
Static tipping load, full turn* (\$)	kg	3982	3844	3933	3931	3423	3499	3688
	lb	<b>8776</b>	<b>8472</b>	<b>8668</b>	<b>8663</b>	<b>7546</b>	<b>7714</b>	<b>8128</b>
Breakout force (\$)	kN	61	55	50	58	56	52	43
	lbf	<b>13,712</b>	<b>12,362</b>	<b>11,239</b>	<b>13,037</b>	<b>12,587</b>	<b>11,688</b>	<b>9665</b>
Operating weight*	kg	6311	6350	6324	6455	6520	6494	6421
	lb	<b>13,909</b>	<b>13,995</b>	<b>13,938</b>	<b>14,231</b>	<b>14,374</b>	<b>14,317</b>	<b>14,151</b>

\*Static tipping load and operating weights shown are with implements, ROPS cab, 12.5-20 tires, full fuel tank and 80 kg (176 lb) operator.  
**NOTE:** Specifications and ratings conform to all applicable standards recommended by the Society of Automotive Engineers (SAE). SAE Standards J732 JUN92 and J742 FEB85 govern loader rating, denoted in the text by (\$).

Bucket Type	General Purpose					
	Pin On					
Ground Engaging Type	Bolt-on Cutting Edges					
Rated capacity 100%	m <sup>3</sup>	1.3	1.4	1.6	1.8	1.9
	yd <sup>3</sup>	<b>1.7</b>	<b>1.8</b>	<b>2.1</b>	<b>2.4</b>	<b>2.5</b>
Rated capacity 110%	m <sup>3</sup>	1.4	1.5	1.7	1.9	2.0
	yd <sup>3</sup>	<b>1.8</b>	<b>2.0</b>	<b>2.2</b>	<b>2.5</b>	<b>2.6</b>
Struck capacity	m <sup>3</sup>	1.15	1.25	1.45	1.65	1.75
	yd <sup>3</sup>	<b>1.5</b>	<b>1.6</b>	<b>1.9</b>	<b>2.2</b>	<b>2.3</b>
Width: bucket	mm	2320	2401	2401	2401	2401
	ft/in	<b>7'7"</b>	<b>7'10"</b>	<b>7'10"</b>	<b>7'10"</b>	<b>7'10"</b>
Nominal material density, 100% fill factor	kg/m <sup>3</sup>	1739	1614	1391	1219	1147
	lb/yd <sup>3</sup>	<b>2930</b>	<b>2766</b>	<b>2336</b>	<b>2015</b>	<b>1922</b>
Nominal material density, 110% fill factor	kg/m <sup>3</sup>	1614	1506	1309	1155	1090
	lb/yd <sup>3</sup>	<b>2721</b>	<b>2539</b>	<b>2207</b>	<b>1946</b>	<b>1837</b>
Clearance: full lift, 45° dump	mm	2849	2846	2792	2738	2713
	ft/in	<b>9'4"</b>	<b>9'4"</b>	<b>9'1"</b>	<b>8'11"</b>	<b>8'10"</b>
Reach: full lift, 45° dump	mm	765	759	811	858	879
	ft/in	<b>2'6"</b>	<b>2'5"</b>	<b>2'7"</b>	<b>2'9"</b>	<b>2'10"</b>
Reach: 2130 mm (7'0") clearance, 45° dump	mm	1346	1338	1361	1377	1383
	ft/in	<b>4'5"</b>	<b>4'4"</b>	<b>4'5"</b>	<b>4'6"</b>	<b>4'6"</b>
Reach: level arm, level bucket	mm	2027	2026	2101	2175	2209
	ft/in	<b>6'7"</b>	<b>6'7"</b>	<b>6'10"</b>	<b>7'1"</b>	<b>7'2"</b>
Dig depth	mm	116	116	116	116	116
	in	<b>4.5</b>	<b>4.5</b>	<b>4.5</b>	<b>4.6</b>	<b>4.5</b>
Length: overall	mm	6227	6226	6301	6375	6409
	ft/in	<b>20'5"</b>	<b>20'5"</b>	<b>20'8"</b>	<b>20'10"</b>	<b>21'0"</b>
Height: overall	mm	4522	4534	4593	4681	4715
	ft/in	<b>14'10"</b>	<b>14'10"</b>	<b>15'0"</b>	<b>15'4"</b>	<b>15'5"</b>
Turning radius, bucket at carry	mm	5143	5180	5202	5224	5234
	ft/in	<b>16'10"</b>	<b>16'11"</b>	<b>17'0"</b>	<b>17'1"</b>	<b>17'2"</b>
Tipping load — straight, ISO 14397-1*	kg	5339	5339	5267	5198	5168
	lb	<b>11,766</b>	<b>11,767</b>	<b>11,607</b>	<b>11,457</b>	<b>11,389</b>
Tipping load — straight, rigid tire**	kg	5561	5562	5486	5415	5383
	lb	<b>12,256</b>	<b>12,257</b>	<b>12,091</b>	<b>11,934</b>	<b>11,863</b>
Tipping load — full turn, ISO 14397-1*	kg	4520	4518	4451	4388	4360
	lb	<b>9963</b>	<b>9958</b>	<b>9810</b>	<b>9671</b>	<b>9609</b>
Tipping load — full turn, rigid tire**	kg	4809	4807	4735	4668	4638
	lb	<b>10,598</b>	<b>10,593</b>	<b>10,436</b>	<b>10,289</b>	<b>10,222</b>
Breakout force	kg	7329	7327	6691	6163	5945
	lbf	<b>16,153</b>	<b>16,148</b>	<b>14,747</b>	<b>13,583</b>	<b>13,101</b>
Operating weight	kg	7110	7130	7169	7204	7220
	lb	<b>15,671</b>	<b>15,714</b>	<b>15,800</b>	<b>15,878</b>	<b>15,913</b>

\*Full compliance to ISO 14397-1 (2007) Sections 1 thru 6, which requires 2% verification between calculation and testing.

\*\*Compliance to ISO 14397-1 (2007) Sections 1 thru 5.

**NOTE:** Dimensions listed are for a 910K configured with buckets, bolt-on cutting edges, optional counterweights, additional guarding, 80 kg (176 lb) operator, and Michelin 15.5 R25 (L2) XTLA tires at a pressure of 4.14 bar (60 psi) in the front tires and 2.76 bar (40 psi) in the rear tires.

Bucket Type	General Purpose										
	IT Quick Coupler						ISO 23727 Quick Coupler				
Ground Engaging Type	Bolt-on Cutting Edges						Bolt-on Cutting Edges				
Rated capacity 100%	m <sup>3</sup>	1.3	1.3	1.5	1.6	1.7	1.9	1.3	1.5	1.7	1.9
	yd <sup>3</sup>	1.7	1.7	2.0	2.1	2.2	2.5	1.7	2.0	2.2	2.5
Rated capacity 110%	m <sup>3</sup>	1.4	1.4	1.6	1.7	1.8	2.0	1.4	1.6	1.8	2.0
	yd <sup>3</sup>	1.8	1.8	2.1	2.2	2.4	2.6	1.8	2.1	2.4	2.6
Struck capacity	m <sup>3</sup>	1.15	1.15	1.35	1.45	1.55	1.75	1.15	1.35	1.55	1.75
	yd <sup>3</sup>	1.5	1.5	1.8	1.9	2.0	2.3	1.5	1.8	2.0	2.3
Width: bucket	mm	2320	2401	2401	2401	2401	2401	2401	2401	2401	2401
	ft/in	7'7"	7'10"	7'10"	7'10"	7'10"	7'10"	7'10"	7'10"	7'10"	7'10"
Nominal material density, 100% fill factor	kg/m <sup>3</sup>	1710	1715	1463	1363	1274	1096	1672	1427	1238	1066
	lb/yd <sup>3</sup>	2883	2890	2419	2289	2169	1836	2817	2359	2108	1785
Nominal material density, 110% fill factor	kg/m <sup>3</sup>	1588	1592	1372	1283	1203	1042	1552	1338	1169	1012
	lb/yd <sup>3</sup>	2677	2683	2313	2162	2028	1756	2616	2255	1970	1706
Clearance: full lift, 45° dump	mm	2778	2809	2747	2721	2694	2636	2772	2709	2656	2610
	ft/in	9'1"	9'2"	9'0"	8'11"	8'10"	8'7"	9'1"	8'10"	8'8"	8'6"
Reach: full lift, 45° dump	mm	843	820	867	888	910	944	863	909	952	991
	ft/in	2'9"	2'8"	2'10"	2'10"	2'11"	3'1"	2'9"	2'11"	3'1"	3'3"
Reach: 2130 mm (7'0") clearance, 45° dump	mm	1385	1380	1392	1397	1402	1398	1403	1411	1420	1428
	ft/in	4'6"	4'6"	4'6"	4'7"	4'7"	4'7"	4'7"	4'7"	4'7"	4'8"
Reach: level arm, level bucket	mm	2132	2092	2172	2207	2243	2311	2149	2228	2298	2360
	ft/in	6'11"	6'10"	7'1"	7'2"	7'4"	7'6"	7'0"	7'3"	7'6"	7'8"
Dig depth	mm	117	117	116	116	117	115	117	117	117	115
	in	4.6	4.6	4.6	4.6	4.6	4.5	4.6	4.6	4.6	4.5
Length: overall	mm	6333	6293	6373	6407	6444	6510	6350	6429	6499	6560
	ft/in	20'9"	20'7"	20'10"	21'0"	21'1"	21'4"	20'10"	21'1"	21'3"	21'6"
Height: overall	mm	4580	4563	4646	4653	4703	4783	4599	4667	4737	4817
	ft/in	15'0"	14'11"	15'2"	15'3"	15'5"	15'8"	15'1"	15'3"	15'6"	15'9"
Turning radius, bucket at carry	mm	5174	5199	5223	5234	5245	5269	5216	5239	5261	5281
	ft/in	16'11"	17'0"	17'1"	17'2"	17'2"	17'3"	17'1"	17'2"	17'3"	17'3"
Tipping load — straight, ISO 14397-1*	kg	5284	5297	5224	5193	5159	4984	5170	5099	5021	4856
	lb	11,645	11,674	11,513	11,444	11,370	10,985	11,394	11,238	11,066	10,702
Tipping load — straight, rigid tire**	kg	5504	5518	5441	5409	5374	5192	5385	5311	5230	5058
	lb	12,130	12,160	11,992	11,921	11,844	11,443	11,869	11,706	11,527	11,148
Tipping load — full turn, ISO 14397-1*	kg	4447	4458	4390	4362	4331	4166	4346	4281	4208	4050
	lb	9801	9825	9676	9613	9545	9182	9578	9434	9274	8925
Tipping load — full turn, rigid tire**	kg	4731	4742	4671	4640	4607	4432	4623	4554	4476	4308
	lb	10,427	10,452	10,294	10,226	10,154	9768	10,189	10,036	9866	9494
Breakout force	kg	6458	6741	6158	5936	5718	5233	6298	5787	5307	4979
	lbf	14,233	14,857	13,572	13,081	12,602	11,533	13,881	12,754	11,695	10,973
Operating weight	kg	7466	7470	7509	7525	7541	7679	7492	7531	7565	7702
	lb	16,454	16,463	16,550	16,585	16,620	16,924	16,512	16,597	16,673	16,975

\*Full compliance to ISO 14397-1 (2007) Sections 1 thru 6, which requires 2% verification between calculation and testing.

\*\*Compliance to ISO 14397-1 (2007) Sections 1 thru 5.

NOTE: Dimensions listed are for a 910K configured with buckets, bolt-on cutting edges, optional counterweights, additional guarding, 80 kg (176 lb) operator, and Michelin 15.5 R25 (L2) XTLA tires at a pressure of 4.14 bar (60 psi) in the front tires and 2.76 bar (40 psi) in the rear tires.

Bucket Type	General Purpose					
	Pin On					
Ground Engaging Type	Bolt-on Cutting Edges					
Rated capacity 100%	m <sup>3</sup>	1.3	1.4	1.6	1.8	1.9
	yd <sup>3</sup>	<b>1.7</b>	<b>1.8</b>	<b>2.1</b>	<b>2.4</b>	<b>2.5</b>
Rated capacity 110%	m <sup>3</sup>	1.4	1.5	1.7	1.9	2.0
	yd <sup>3</sup>	<b>1.8</b>	<b>2.0</b>	<b>2.2</b>	<b>2.5</b>	<b>2.6</b>
Struck capacity	m <sup>3</sup>	1.15	1.25	1.45	1.65	1.75
	yd <sup>3</sup>	<b>1.5</b>	<b>1.6</b>	<b>1.9</b>	<b>2.2</b>	<b>2.3</b>
Width: bucket	mm	2320	2401	2401	2401	2401
	ft/in	<b>7'7"</b>	<b>7'10"</b>	<b>7'10"</b>	<b>7'10"</b>	<b>7'10"</b>
Nominal material density, 100% fill factor	kg/m <sup>3</sup>	1616	1498	1294	1135	1069
	lb/yd <sup>3</sup>	<b>2723</b>	<b>2568</b>	<b>2172</b>	<b>1876</b>	<b>1791</b>
Nominal material density, 110% fill factor	kg/m <sup>3</sup>	1500	1398	1217	1076	1016
	lb/yd <sup>3</sup>	<b>2529</b>	<b>2357</b>	<b>2052</b>	<b>1813</b>	<b>1712</b>
Clearance: full lift, 45° dump	mm	3205	3202	3149	3094	3069
	ft/in	<b>10'6"</b>	<b>10'6"</b>	<b>10'3"</b>	<b>10'1"</b>	<b>10'0"</b>
Reach: full lift, 45° dump	mm	984	978	1030	1077	1099
	ft/in	<b>3'2"</b>	<b>3'2"</b>	<b>3'4"</b>	<b>3'6"</b>	<b>3'7"</b>
Reach: 2130 mm (7'0") clearance, 45° dump	mm	1806	1798	1826	1848	1857
	ft/in	<b>5'11"</b>	<b>5'10"</b>	<b>5'11"</b>	<b>6'0"</b>	<b>6'1"</b>
Reach: level arm, level bucket	mm	2442	2441	2516	2590	2624
	ft/in	<b>8'0"</b>	<b>8'0"</b>	<b>8'3"</b>	<b>8'5"</b>	<b>8'7"</b>
Dig depth	mm	294	294	294	294	294
	in	<b>11.6</b>	<b>11.6</b>	<b>11.6</b>	<b>11.6</b>	<b>11.6</b>
Length: overall	mm	6759	6758	6834	6907	6941
	ft/in	<b>22'2"</b>	<b>22'2"</b>	<b>22'5"</b>	<b>22'7"</b>	<b>22'9"</b>
Height: overall	mm	4879	4891	4949	5037	5071
	ft/in	<b>16'0"</b>	<b>16'0"</b>	<b>16'2"</b>	<b>16'6"</b>	<b>16'7"</b>
Turning radius, bucket at carry	mm	5384	5419	5443	5466	5476
	ft/in	<b>17'7"</b>	<b>17'9"</b>	<b>17'10"</b>	<b>17'11"</b>	<b>17'11"</b>
Tipping load — straight, ISO 14397-1*	kg	5008	5005	4945	4889	4864
	lb	<b>11,037</b>	<b>11,031</b>	<b>10,899</b>	<b>10,775</b>	<b>10,719</b>
Tipping load — straight, rigid tire**	kg	5217	5214	5151	5093	5067
	lb	<b>11,497</b>	<b>11,490</b>	<b>11,353</b>	<b>11,224</b>	<b>11,166</b>
Tipping load — full turn, ISO 14397-1*	kg	4201	4195	4139	4087	4064
	lb	<b>9258</b>	<b>9246</b>	<b>9123</b>	<b>9007</b>	<b>8955</b>
Tipping load — full turn, rigid tire**	kg	4469	4463	4404	4348	4323
	lb	<b>9849</b>	<b>9836</b>	<b>9705</b>	<b>9582</b>	<b>9527</b>
Breakout force	kg	7394	7392	6751	6218	5998
	lbf	<b>16,296</b>	<b>16,291</b>	<b>14,879</b>	<b>13,705</b>	<b>13,220</b>
Operating weight	kg	7620	7639	7678	7714	7729
	lb	<b>16,793</b>	<b>16,837</b>	<b>16,922</b>	<b>17,000</b>	<b>17,035</b>

\*Full compliance to ISO 14397-1 (2007) Sections 1 thru 6, which requires 2% verification between calculation and testing.

\*\*Compliance to ISO 14397-1 (2007) Sections 1 thru 5.

**NOTE:** Dimensions listed are for a 910K configured with buckets, bolt-on cutting edges, optional counterweights, additional guarding, 80 kg (176 lb) operator, and Michelin 15.5 R25 (L2) XTLA tires at a pressure of 4.14 bar (60 psi) in the front tires and 2.76 bar (40 psi) in the rear tires.

Bucket Type	General Purpose										
	IT Quick Coupler					ISO 23727 Quick Coupler					
Ground Engaging Type	Bolt-on Cutting Edges										
Rated capacity 100%	m <sup>3</sup>	1.3	1.3	1.5	1.6	1.7	1.9	1.3	1.5	1.7	1.9
	yd <sup>3</sup>	1.7	1.7	2.0	2.1	2.2	2.5	1.7	2.0	2.2	2.5
Rated capacity 110%	m <sup>3</sup>	1.4	1.4	1.6	1.7	1.8	2.0	1.4	1.6	1.8	2.0
	yd <sup>3</sup>	1.8	1.8	2.1	2.2	2.4	2.6	1.8	2.1	2.4	2.6
Struck capacity	m <sup>3</sup>	1.15	1.15	1.35	1.45	1.55	1.75	1.15	1.35	1.55	1.75
	yd <sup>3</sup>	1.5	1.5	1.8	1.9	2.0	2.3	1.5	1.8	2.0	2.3
Width: bucket	mm	2320	2401	2401	2401	2401	2401	2401	2401	2401	2401
	ft/in	7'7"	7'10"	7'10"	7'10"	7'10"	7'10"	7'10"	7'10"	7'10"	7'10"
Nominal material density, 100% fill factor	kg/m <sup>3</sup>	1584	1587	1356	1264	1182	923	1553	1327	1154	896
	lb/yd <sup>3</sup>	2670	2674	2242	2122	2013	1546	2617	2194	1965	1502
Nominal material density, 110% fill factor	kg/m <sup>3</sup>	1471	1473	1271	1190	1116	877	1442	1244	1090	852
	lb/yd <sup>3</sup>	2480	2483	2143	2005	1882	1478	2430	2097	1837	1435
Clearance: full lift, 45° dump	mm	3135	3166	3103	3077	3050	3163	3128	3066	3012	3150
	ft/in	10'3"	10'4"	10'2"	10'1"	10'0"	10'4"	10'3"	10'0"	9'10"	10'4"
Reach: full lift, 45° dump	mm	1062	1039	1086	1107	1130	1361	1083	1128	1171	1414
	ft/in	3'5"	3'4"	3'6"	3'7"	3'8"	4'5"	3'6"	3'8"	3'10"	4'7"
Reach: 2130 mm (7'0") clearance, 45° dump	mm	1852	1843	1861	1870	1878	1881	1869	1884	1900	1915
	ft/in	6'0"	6'0"	6'1"	6'1"	6'1"	6'2"	6'1"	6'2"	6'2"	6'3"
Reach: level arm, level bucket	mm	2546	2507	2587	2621	2657	2725	2564	2643	2713	2775
	ft/in	8'4"	8'2"	8'5"	8'7"	8'8"	8'11"	8'4"	8'8"	8'10"	9'1"
Dig depth	mm	295	295	295	295	295	294	295	295	295	293
	in	11.6	11.6	11.6	11.6	11.6	11.6	11.6	11.6	11.6	11.6
Length: overall	mm	6865	6825	6905	6939	6976	7043	6882	6961	7031	7092
	ft/in	22'6"	22'4"	22'7"	22'9"	22'10"	23'1"	22'6"	22'10"	23'0"	23'3"
Height: overall	mm	4937	4920	5002	5009	5059	5140	4955	5023	5094	5174
	ft/in	16'2"	16'1"	16'4"	16'5"	16'7"	16'10"	16'3"	16'5"	16'8"	16'11"
Turning radius, bucket at carry	mm	5417	5440	5465	5476	5487	5156	5452	5478	5500	5049
	ft/in	17'9"	17'10"	17'11"	17'11"	18'0"	16'10"	17'10"	17'11"	18'0"	16'6"
Tipping load — straight, ISO 14397-1*	kg	4942	4949	4889	4863	4836	4251	4849	4790	4728	4139
	lb	10,892	10,907	10,774	10,718	10,657	9369	10,688	10,558	10,419	9122
Tipping load — straight, rigid tire**	kg	5148	5155	5092	5066	5037	4428	5051	4990	4925	4311
	lb	11,346	11,362	11,223	11,165	11,102	9759	11,133	10,998	10,853	9502
Tipping load — full turn, ISO 14397-1*	kg	4120	4125	4069	4045	4019	3507	4037	3982	3923	3407
	lb	9079	9091	8967	8914	8858	7730	8897	8776	8645	7508
Tipping load — full turn, rigid tire**	kg	4383	4388	4328	4303	4276	3731	4295	4236	4173	3624
	lb	9659	9671	9539	9483	9423	8223	9465	9336	9197	7987
Breakout force	kg	6514	6800	6212	5988	5769	5298	6351	5836	5353	5026
	lbf	14,357	14,987	13,692	13,198	12,714	11,676	13,998	12,862	11,797	11,077
Operating weight	kg	7975	7979	8019	8035	8051	8188	8002	8040	8074	8212
	lb	17,576	17,586	17,673	17,708	17,743	18,047	17,635	17,720	17,795	18,098

\*Full compliance to ISO 14397-1 (2007) Sections 1 thru 6, which requires 2% verification between calculation and testing.

\*\*Compliance to ISO 14397-1 (2007) Sections 1 thru 5.

**NOTE:** Dimensions listed are for a 910K configured with buckets, bolt-on cutting edges, optional counterweights, additional guarding, 80 kg (176 lb) operator, and Michelin 15.5 R25 (L2) XTLA tires at a pressure of 4.14 bar (60 psi) in the front tires and 2.76 bar (40 psi) in the rear tires.



# Wheel Loaders Integrated Toolcarriers

## Performance Data

- 910K
- Pallet Forks
- Material Handling Arm

		Pallet Forks — Standard Lift IT		Pallet Forks — High Lift IT	
Fork tine length	mm	1200		1200	
	ft/in	3'11"		3'11"	
Load center	mm	600		600	
	ft/in	1'11"		1'11"	
Overall length	mm	6719		7259	
	ft/in	22'0"		23'9"	
Ground reach	mm	693		1233	
	ft/in	2'3"		4'0"	
Digging depth	mm	78		256	
	in	3.1		10.1	
Level arm reach	mm	1354		1769	
	ft/in	4'5"		5'9"	
Full lift reach	mm	502		722	
	ft/in	1'7"		2'4"	
Level arm clearance	mm	1640		1640	
	ft/in	5'4"		5'4"	
Full lift clearance	mm	3457		3813	
	ft/in	11'4"		12'6"	
Overall height	mm	4443		4800	
	ft/in	14'6"		15'8"	
Tipping load — straight (ISO 14397-1)*	kg	4097		3943	
	lb	9028		8690	
Tipping load — full turn (ISO 14397-1)*	kg	3456		3295	
	lb	7615		7261	
Operating weight	kg	7368		7877	
	lb	16,238		17,361	
Rated load (% of full turn tip): 50% of tip (SAE J1197)**	kg	1728		1647	
	lb	3807		3630	
Rated load (% of full turn tip): 60% of tip — rough terrain (EN474-3)**	kg	2073		1977	
	lb	4569		4356	
Rated load (% of full turn tip): 80% of tip — firm and level (EN474-3)**	kg	2764		2636	
	lb	6092		5809	
Minimum fork spacing	mm	300		300	
	in	11		11	
Carriage width	mm	1550		1550	
	ft/in	5'1"		5'1"	
Maximum fork spacing	mm	1526		1526	
	ft/in	5'0"		5'0"	

\*Full compliance to ISO 14397-1 (2007) Sections 1 thru 6, which requires 2% verification between calculation and testing.

\*\*Full compliance to EN474-3 and SAE J1197.

**NOTE:** Dimensions listed are for a machine configured with IT work tools, 80 kg (176 lb) operator, and standard tires.

		Material Handling Arm — Standard Lift			Material Handling Arm — High Lift		
Handling Arm Position		Retracted	Mid-position	Extended	Retracted	Mid-position	Extended
Rated load (50% of full turn tip* SAE J1197)	kg	1153	901	741	1153	922	769
	lb	2540	1986	1634	2541	2031	1695
Operating weight	kg	7336	7336	7336	7846	7846	7846
	lb	16,169	16,169	16,169	17,292	17,292	17,292

\*Full compliance to EN474-3 and SAE J1197.

Bucket Type	General Purpose					
	Pin On					
Ground Engaging Type	Bolt-on Cutting Edges					
Rated capacity 100%	m <sup>3</sup>	1.3	1.4	1.6	1.8	1.9
	yd <sup>3</sup>	<b>1.7</b>	<b>1.8</b>	<b>2.1</b>	<b>2.4</b>	<b>2.5</b>
Rated capacity 110%	m <sup>3</sup>	1.4	1.5	1.7	1.9	2.0
	yd <sup>3</sup>	<b>1.8</b>	<b>2.0</b>	<b>2.2</b>	<b>2.5</b>	<b>2.6</b>
Struck capacity	m <sup>3</sup>	1.15	1.25	1.45	1.65	1.75
	yd <sup>3</sup>	<b>1.5</b>	<b>1.6</b>	<b>1.9</b>	<b>2.2</b>	<b>2.3</b>
Width: bucket	mm	2320	2401	2401	2401	2401
	ft/in	<b>7'7"</b>	<b>7'10"</b>	<b>7'10"</b>	<b>7'10"</b>	<b>7'10"</b>
Nominal material density, 100% fill factor	kg/m <sup>3</sup>	2145	1992	1720	1509	1422
	lb/yd <sup>3</sup>	<b>3615</b>	<b>3415</b>	<b>2888</b>	<b>2495</b>	<b>2381</b>
Nominal material density, 110% fill factor	kg/m <sup>3</sup>	1992	1859	1619	1430	1351
	lb/yd <sup>3</sup>	<b>3357</b>	<b>3134</b>	<b>2728</b>	<b>2410</b>	<b>2276</b>
Clearance: full lift, 45° dump	mm	2877	2874	2820	2766	2741
	ft/in	<b>9'5"</b>	<b>9'5"</b>	<b>9'3"</b>	<b>9'0"</b>	<b>8'11"</b>
Reach: full lift, 45° dump	mm	744	737	790	838	860
	ft/in	<b>2'5"</b>	<b>2'5"</b>	<b>2'7"</b>	<b>2'8"</b>	<b>2'9"</b>
Reach: 2130 mm (7'0") clearance, 45° dump	mm	1335	1327	1352	1370	1377
	ft/in	<b>4'4"</b>	<b>4'4"</b>	<b>4'5"</b>	<b>4'5"</b>	<b>4'6"</b>
Reach: level arm, level bucket	mm	1998	1996	2072	2146	2179
	ft/in	<b>6'6"</b>	<b>6'6"</b>	<b>6'9"</b>	<b>7'0"</b>	<b>7'1"</b>
Dig depth	mm	89	89	89	89	89
	in	<b>3.5</b>	<b>3.5</b>	<b>3.5</b>	<b>3.5</b>	<b>3.5</b>
Length: overall	mm	6216	6215	6291	6364	6398
	ft/in	<b>20'4"</b>	<b>20'4"</b>	<b>20'7"</b>	<b>20'10"</b>	<b>20'11"</b>
Height: overall	mm	4551	4562	4621	4709	4743
	ft/in	<b>14'11"</b>	<b>14'11"</b>	<b>15'1"</b>	<b>15'5"</b>	<b>15'6"</b>
Turning radius, bucket at carry	mm	5141	5178	5200	5223	5233
	ft/in	<b>16'10"</b>	<b>16'11"</b>	<b>17'0"</b>	<b>17'1"</b>	<b>17'2"</b>
Tipping load — straight, ISO 14397-1*	kg	6594	6599	6518	6441	6406
	lb	<b>14,533</b>	<b>14,544</b>	<b>14,364</b>	<b>14,196</b>	<b>14,119</b>
Tipping load — straight, rigid tire**	kg	6869	6874	6789	6710	6673
	lb	<b>15,139</b>	<b>15,150</b>	<b>14,963</b>	<b>14,787</b>	<b>14,708</b>
Tipping load — full turn, ISO 14397-1*	kg	5577	5578	5504	5434	5402
	lb	<b>12,291</b>	<b>12,294</b>	<b>12,130</b>	<b>11,976</b>	<b>11,906</b>
Tipping load — full turn, rigid tire**	kg	5933	5934	5855	5781	5747
	lb	<b>13,075</b>	<b>13,079</b>	<b>12,904</b>	<b>12,740</b>	<b>12,666</b>
Breakout force	kg	8731	8730	7981	7358	7101
	lbf	<b>19,242</b>	<b>19,241</b>	<b>17,589</b>	<b>16,217</b>	<b>15,649</b>
Operating weight	kg	8068	8088	8126	8162	8178
	lb	<b>17,781</b>	<b>17,825</b>	<b>17,910</b>	<b>17,988</b>	<b>18,023</b>

\*Full compliance to ISO 14397-1 (2007) Sections 1 thru 6, which requires 2% verification between calculation and testing.

\*\*Compliance to ISO 14397-1 (2007) Sections 1 thru 5.

**NOTE:** Dimensions listed are for a 914K configured with buckets, bolt-on cutting edges, optional counterweights, additional guarding, 80 kg (176 lb) operator, and Michelin 15.5 R25 (L2) XTLA tires at a pressure of 4.14 bar (60 psi) in the front tires and 2.76 bar (40 psi) in the rear tires.

# Wheel Loaders Integrated Toolcarriers

## Performance Data ● 914K Standard Lift

Bucket Type	General Purpose										
	IT Quick Coupler						ISO 23727 Quick Coupler				
Ground Engaging Type	Bolt-on Cutting Edges						Bolt-on Cutting Edges				
Rated capacity 100%	m <sup>3</sup>	1.3	1.3	1.5	1.6	1.7	1.9	1.3	1.5	1.7	1.9
	yd <sup>3</sup>	<b>1.7</b>	<b>1.7</b>	<b>2.0</b>	<b>2.1</b>	<b>2.2</b>	<b>2.5</b>	<b>1.7</b>	<b>2.0</b>	<b>2.2</b>	<b>2.5</b>
Rated capacity 110%	m <sup>3</sup>	1.4	1.4	1.6	1.7	1.8	2.0	1.4	1.6	1.8	2.0
	yd <sup>3</sup>	<b>1.8</b>	<b>1.8</b>	<b>2.1</b>	<b>2.2</b>	<b>2.4</b>	<b>2.6</b>	<b>1.8</b>	<b>2.1</b>	<b>2.4</b>	<b>2.6</b>
Struck capacity	m <sup>3</sup>	1.15	1.15	1.35	1.45	1.55	1.75	1.15	1.35	1.55	1.75
	yd <sup>3</sup>	<b>1.5</b>	<b>1.5</b>	<b>1.8</b>	<b>1.9</b>	<b>2.0</b>	<b>2.3</b>	<b>1.5</b>	<b>1.8</b>	<b>2.0</b>	<b>2.3</b>
Width: bucket	mm	2320	2401	2401	2401	2401	2401	2401	2401	2401	2401
	ft/in	<b>7'7"</b>	<b>7'10"</b>	<b>7'10"</b>	<b>7'10"</b>	<b>7'10"</b>	<b>7'10"</b>	<b>7'10"</b>	<b>7'10"</b>	<b>7'10"</b>	<b>7'10"</b>
Nominal material density, 100% fill factor	kg/m <sup>3</sup>	2101	2107	1801	1678	1570	1357	2057	1758	1528	1323
	lb/yd <sup>3</sup>	<b>3541</b>	<b>3550</b>	<b>2977</b>	<b>2818</b>	<b>2673</b>	<b>2273</b>	<b>3466</b>	<b>2907</b>	<b>2603</b>	<b>2217</b>
Nominal material density, 110% fill factor	kg/m <sup>3</sup>	1951	1956	1688	1580	1482	1289	1910	1649	1443	1257
	lb/yd <sup>3</sup>	<b>3289</b>	<b>3297</b>	<b>2846</b>	<b>2663</b>	<b>2499</b>	<b>2173</b>	<b>3219</b>	<b>2779</b>	<b>2433</b>	<b>2119</b>
Clearance: full lift, 45° dump	mm	2806	2838	2775	2749	2722	2664	2800	2738	2684	2638
	ft/in	<b>9'2"</b>	<b>9'3"</b>	<b>9'1"</b>	<b>9'0"</b>	<b>8'11"</b>	<b>8'8"</b>	<b>9'2"</b>	<b>8'11"</b>	<b>8'9"</b>	<b>8'7"</b>
Reach: full lift, 45° dump	mm	822	799	847	868	891	925	843	889	933	973
	ft/in	<b>2'8"</b>	<b>2'7"</b>	<b>2'9"</b>	<b>2'10"</b>	<b>2'11"</b>	<b>3'0"</b>	<b>2'9"</b>	<b>2'10"</b>	<b>3'0"</b>	<b>3'2"</b>
Reach: 2130 mm (7'0") clearance, 45° dump	mm	1377	1370	1384	1390	1396	1394	1394	1404	1415	1425
	ft/in	<b>4'6"</b>	<b>4'5"</b>	<b>4'6"</b>	<b>4'6"</b>	<b>4'6"</b>	<b>4'6"</b>	<b>4'6"</b>	<b>4'7"</b>	<b>4'7"</b>	<b>4'8"</b>
Reach: level arm, level bucket	mm	2102	2063	2143	2177	2213	2281	2120	2199	2269	2331
	ft/in	<b>6'10"</b>	<b>6'9"</b>	<b>7'0"</b>	<b>7'1"</b>	<b>7'3"</b>	<b>7'5"</b>	<b>6'11"</b>	<b>7'2"</b>	<b>7'5"</b>	<b>7'7"</b>
Dig depth	mm	90	90	89	89	90	88	90	90	90	88
	in	<b>3.5</b>	<b>3.5</b>	<b>3.5</b>	<b>3.5</b>	<b>3.5</b>	<b>3.5</b>	<b>3.5</b>	<b>3.5</b>	<b>3.5</b>	<b>3.5</b>
Length: overall	mm	6322	6282	6362	6397	6433	6500	6340	6419	6489	6549
	ft/in	<b>20'8"</b>	<b>20'7"</b>	<b>20'10"</b>	<b>20'11"</b>	<b>21'1"</b>	<b>21'3"</b>	<b>20'9"</b>	<b>21'0"</b>	<b>21'3"</b>	<b>21'5"</b>
Height: overall	mm	4608	4591	4674	4681	4731	4811	4627	4695	4765	4845
	ft/in	<b>15'1"</b>	<b>15'0"</b>	<b>15'4"</b>	<b>15'4"</b>	<b>15'6"</b>	<b>15'9"</b>	<b>15'2"</b>	<b>15'4"</b>	<b>15'7"</b>	<b>15'10"</b>
Turning radius, bucket at carry	mm	5172	5198	5222	5232	5244	5268	5216	5240	5262	5282
	ft/in	<b>16'11"</b>	<b>17'0"</b>	<b>17'1"</b>	<b>17'2"</b>	<b>17'2"</b>	<b>17'3"</b>	<b>17'1"</b>	<b>17'2"</b>	<b>17'3"</b>	<b>17'3"</b>
Tipping load — straight, ISO 14397-1*	kg	6491	6508	6426	6391	6354	6163	6360	6281	6195	6020
	lb	<b>14,305</b>	<b>14,343</b>	<b>14,163</b>	<b>14,086</b>	<b>14,004</b>	<b>13,583</b>	<b>14,016</b>	<b>13,842</b>	<b>13,654</b>	<b>13,268</b>
Tipping load — straight, rigid tire**	kg	6761	6779	6694	6658	6619	6420	6625	6542	6453	6271
	lb	<b>14,901</b>	<b>14,940</b>	<b>14,753</b>	<b>14,673</b>	<b>14,587</b>	<b>14,149</b>	<b>14,600</b>	<b>14,419</b>	<b>14,222</b>	<b>13,821</b>
Tipping load — full turn, ISO 14397-1*	kg	5463	5477	5403	5371	5337	5158	5348	5275	5196	5029
	lb	<b>12,040</b>	<b>12,071</b>	<b>11,907</b>	<b>11,837</b>	<b>11,762</b>	<b>11,367</b>	<b>11,786</b>	<b>11,626</b>	<b>11,452</b>	<b>11,083</b>
Tipping load — full turn, rigid tire**	kg	5812	5827	5748	5714	5677	5487	5689	5612	5528	5350
	lb	<b>12,809</b>	<b>12,842</b>	<b>12,667</b>	<b>12,593</b>	<b>12,513</b>	<b>12,093</b>	<b>12,538</b>	<b>12,369</b>	<b>12,183</b>	<b>11,790</b>
Breakout force	kg	7708	8045	7357	7095	6838	6277	7527	6924	6372	5987
	lbf	<b>16,987</b>	<b>17,730</b>	<b>16,214</b>	<b>15,636</b>	<b>15,071</b>	<b>13,835</b>	<b>16,589</b>	<b>15,259</b>	<b>14,044</b>	<b>13,196</b>
Operating weight	kg	8423	8427	8467	8483	8499	8637	8450	8488	8523	8660
	lb	<b>18,564</b>	<b>18,573</b>	<b>18,661</b>	<b>18,695</b>	<b>18,731</b>	<b>19,034</b>	<b>18,623</b>	<b>18,708</b>	<b>18,783</b>	<b>19,086</b>

\*Full compliance to ISO 14397-1 (2007) Sections 1 thru 6, which requires 2% verification between calculation and testing.

\*\*Compliance to ISO 14397-1 (2007) Sections 1 thru 5.

**NOTE:** Dimensions listed are for a 914K configured with buckets, bolt-on cutting edges, optional counterweights, additional guarding, 80 kg (176 lb) operator, and Michelin 15.5 R25 (L2) XTLA tires at a pressure of 4.14 bar (60 psi) in the front tires and 2.76 bar (40 psi) in the rear tires.

Bucket Type	General Purpose					
	Pin On					
Ground Engaging Type	Bolt-on Cutting Edges					
Rated capacity 100%	m <sup>3</sup>	1.3	1.4	1.6	1.8	1.9
	yd <sup>3</sup>	<b>1.7</b>	<b>1.8</b>	<b>2.1</b>	<b>2.4</b>	<b>2.5</b>
Rated capacity 110%	m <sup>3</sup>	1.4	1.5	1.7	1.9	2.0
	yd <sup>3</sup>	<b>1.8</b>	<b>2.0</b>	<b>2.2</b>	<b>2.5</b>	<b>2.6</b>
Struck capacity	m <sup>3</sup>	1.15	1.25	1.45	1.65	1.75
	yd <sup>3</sup>	<b>1.5</b>	<b>1.6</b>	<b>1.9</b>	<b>2.2</b>	<b>2.3</b>
Width: bucket	mm	2320	2401	2401	2401	2401
	ft/in	<b>7'7"</b>	<b>7'10"</b>	<b>7'10"</b>	<b>7'10"</b>	<b>7'10"</b>
Nominal material density, 100% fill factor	kg/m <sup>3</sup>	1721	1596	1379	1210	1140
	lb/yd <sup>3</sup>	<b>2900</b>	<b>2736</b>	<b>2315</b>	<b>2001</b>	<b>1910</b>
Nominal material density, 110% fill factor	kg/m <sup>3</sup>	1598	1490	1298	1147	1083
	lb/yd <sup>3</sup>	<b>2693</b>	<b>2511</b>	<b>2187</b>	<b>1933</b>	<b>1826</b>
Clearance: full lift, 45° dump	mm	3230	3227	3174	3120	3094
	ft/in	<b>10'7"</b>	<b>10'7"</b>	<b>10'4"</b>	<b>10'2"</b>	<b>10'1"</b>
Reach: full lift, 45° dump	mm	963	956	1009	1057	1079
	ft/in	<b>3'1"</b>	<b>3'1"</b>	<b>3'3"</b>	<b>3'5"</b>	<b>3'6"</b>
Reach: 2130 mm (7'0") clearance, 45° dump	mm	1790	1782	1812	1835	1845
	ft/in	<b>5'10"</b>	<b>5'10"</b>	<b>5'11"</b>	<b>6'0"</b>	<b>6'0"</b>
Reach: level arm, level bucket	mm	2412	2411	2487	2560	2594
	ft/in	<b>7'10"</b>	<b>7'10"</b>	<b>8'1"</b>	<b>8'4"</b>	<b>8'6"</b>
Dig depth	mm	272	272	272	272	272
	in	<b>10.7</b>	<b>10.7</b>	<b>10.7</b>	<b>10.7</b>	<b>10.7</b>
Length: overall	mm	6760	6758	6834	6908	6941
	ft/in	<b>22'2"</b>	<b>22'2"</b>	<b>22'5"</b>	<b>22'7"</b>	<b>22'9"</b>
Height: overall	mm	4904	4916	4974	5062	5096
	ft/in	<b>16'1"</b>	<b>16'1"</b>	<b>16'3"</b>	<b>16'7"</b>	<b>16'8"</b>
Turning radius, bucket at carry	mm	5389	5424	5448	5471	5482
	ft/in	<b>17'8"</b>	<b>17'9"</b>	<b>17'10"</b>	<b>17'11"</b>	<b>17'11"</b>
Tipping load — straight, ISO 14397-1*	kg	5319	5317	5254	5196	5170
	lb	<b>11,722</b>	<b>11,717</b>	<b>11,580</b>	<b>11,452</b>	<b>11,394</b>
Tipping load — straight, rigid tire**	kg	5540	5538	5473	5413	5385
	lb	<b>12,211</b>	<b>12,205</b>	<b>12,063</b>	<b>11,929</b>	<b>11,869</b>
Tipping load — full turn, ISO 14397-1*	kg	4474	4469	4412	4357	4333
	lb	<b>9860</b>	<b>9850</b>	<b>9722</b>	<b>9603</b>	<b>9549</b>
Tipping load — full turn, rigid tire**	kg	4760	4755	4693	4635	4609
	lb	<b>10,490</b>	<b>10,479</b>	<b>10,343</b>	<b>10,216</b>	<b>10,159</b>
Breakout force	kg	8861	8861	8100	7469	7208
	lbf	<b>19,528</b>	<b>19,528</b>	<b>17,853</b>	<b>16,460</b>	<b>15,886</b>
Operating weight	kg	8122	8142	8181	8216	8232
	lb	<b>17,901</b>	<b>17,944</b>	<b>18,030</b>	<b>18,108</b>	<b>18,143</b>

\*Full compliance to ISO 14397-1 (2007) Sections 1 thru 6, which requires 2% verification between calculation and testing.

\*\*Compliance to ISO 14397-1 (2007) Sections 1 thru 5.

**NOTE:** Dimensions listed are for a 914K configured with buckets, bolt-on cutting edges, optional counterweights, additional guarding, 80 kg (176 lb) operator, and Michelin 15.5 R25 (L2) XTLA tires at a pressure of 4.14 bar (60 psi) in the front tires and 2.76 bar (40 psi) in the rear tires.

# Wheel Loaders Integrated Toolcarriers

## Performance Data ● 914K High Lift

Bucket Type	General Purpose										
	IT Quick Coupler						ISO 23727 Quick Coupler				
Ground Engaging Type	Bolt-on Cutting Edges						Bolt-on Cutting Edges				
Rated capacity 100%	m <sup>3</sup>	1.3	1.3	1.5	1.6	1.7	1.9	1.3	1.5	1.7	1.9
	yd <sup>3</sup>	<b>1.7</b>	<b>1.7</b>	<b>2.0</b>	<b>2.1</b>	<b>2.2</b>	<b>2.5</b>	<b>1.7</b>	<b>2.0</b>	<b>2.2</b>	<b>2.5</b>
Rated capacity 110%	m <sup>3</sup>	1.4	1.4	1.6	1.7	1.8	2.0	1.4	1.6	1.8	2.0
	yd <sup>3</sup>	<b>1.8</b>	<b>1.8</b>	<b>2.1</b>	<b>2.2</b>	<b>2.4</b>	<b>2.6</b>	<b>1.8</b>	<b>2.1</b>	<b>2.4</b>	<b>2.6</b>
Struck capacity	m <sup>3</sup>	1.15	1.15	1.35	1.45	1.55	1.75	1.15	1.35	1.55	1.75
	yd <sup>3</sup>	<b>1.5</b>	<b>1.5</b>	<b>1.8</b>	<b>1.9</b>	<b>2.0</b>	<b>2.3</b>	<b>1.5</b>	<b>1.8</b>	<b>2.0</b>	<b>2.3</b>
Width: bucket	mm	2320	2401	2401	2401	2401	2401	2401	2401	2401	2401
	ft/in	<b>7'7"</b>	<b>7'10"</b>	<b>7'10"</b>	<b>7'10"</b>	<b>7'10"</b>	<b>7'10"</b>	<b>7'10"</b>	<b>7'10"</b>	<b>7'10"</b>	<b>7'10"</b>
Nominal material density, 100% fill factor	kg/m <sup>3</sup>	1686	1688	1444	1346	1259	987	1653	1414	1229	1323
	lb/yd <sup>3</sup>	<b>2841</b>	<b>2846</b>	<b>2387</b>	<b>2260</b>	<b>2144</b>	<b>1653</b>	<b>2786</b>	<b>2337</b>	<b>2094</b>	<b>2217</b>
Nominal material density, 110% fill factor	kg/m <sup>3</sup>	1566	1568	1354	1267	1189	938	1535	1325	1161	1257
	lb/yd <sup>3</sup>	<b>2639</b>	<b>2643</b>	<b>2282</b>	<b>2135</b>	<b>2004</b>	<b>1580</b>	<b>2587</b>	<b>2234</b>	<b>1957</b>	<b>2119</b>
Clearance: full lift, 45° dump	mm	3160	3191	3129	3103	3075	3176	3153	3091	3037	2638
	ft/in	<b>10'4"</b>	<b>10'5"</b>	<b>10'3"</b>	<b>10'2"</b>	<b>10'1"</b>	<b>10'5"</b>	<b>10'4"</b>	<b>10'1"</b>	<b>9'11"</b>	<b>8'7"</b>
Reach: full lift, 45° dump	mm	1041	1018	1066	1088	1110	1328	1062	1108	1152	973
	ft/in	<b>3'4"</b>	<b>3'4"</b>	<b>3'5"</b>	<b>3'6"</b>	<b>3'7"</b>	<b>4'4"</b>	<b>3'5"</b>	<b>3'7"</b>	<b>3'9"</b>	<b>3'2"</b>
Reach: 2130 mm (7'0") clearance, 45° dump	mm	1838	1829	1848	1857	1866	1871	1856	1872	1889	1425
	ft/in	<b>6'0"</b>	<b>5'11"</b>	<b>6'0"</b>	<b>6'1"</b>	<b>6'1"</b>	<b>6'1"</b>	<b>6'1"</b>	<b>6'1"</b>	<b>6'2"</b>	<b>4'8"</b>
Reach: level arm, level bucket	mm	2517	2477	2558	2592	2628	2696	2535	2614	2684	2331
	ft/in	<b>8'3"</b>	<b>8'1"</b>	<b>8'4"</b>	<b>8'6"</b>	<b>8'7"</b>	<b>8'10"</b>	<b>8'3"</b>	<b>8'6"</b>	<b>8'9"</b>	<b>7'7"</b>
Dig depth	mm	274	274	273	273	273	272	273	273	273	272
	in	<b>10.8</b>	<b>10.8</b>	<b>10.8</b>	<b>10.8</b>	<b>10.8</b>	<b>10.7</b>	<b>10.8</b>	<b>10.8</b>	<b>10.8</b>	<b>10.7</b>
Length: overall	mm	6865	6825	6905	6940	6976	7043	6883	6962	7032	6549
	ft/in	<b>22'6"</b>	<b>22'4"</b>	<b>22'7"</b>	<b>22'9"</b>	<b>22'10"</b>	<b>23'1"</b>	<b>22'6"</b>	<b>22'10"</b>	<b>23'0"</b>	<b>21'5"</b>
Height: overall	mm	4962	4945	5027	5034	5084	5165	4980	5048	5119	4845
	ft/in	<b>16'3"</b>	<b>16'2"</b>	<b>16'5"</b>	<b>16'6"</b>	<b>16'8"</b>	<b>16'11"</b>	<b>16'4"</b>	<b>16'6"</b>	<b>16'9"</b>	<b>15'10"</b>
Turning radius, bucket at carry	mm	5422	5445	5471	5482	5494	5179	5458	5484	5507	5282
	ft/in	<b>17'9"</b>	<b>17'10"</b>	<b>17'11"</b>	<b>17'11"</b>	<b>18'0"</b>	<b>16'11"</b>	<b>17'10"</b>	<b>17'11"</b>	<b>18'0"</b>	<b>17'3"</b>
Tipping load — straight, ISO 14397-1*	kg	5242	5250	5187	5161	5132	4527	5146	5085	5019	6020
	lb	<b>11,553</b>	<b>11,571</b>	<b>11,433</b>	<b>11,374</b>	<b>11,311</b>	<b>9977</b>	<b>11,341</b>	<b>11,206</b>	<b>11,062</b>	<b>13,268</b>
Tipping load — straight, rigid tire**	kg	5461	5469	5404	5376	5346	4716	5360	5297	5229	6271
	lb	<b>12,035</b>	<b>12,053</b>	<b>11,909</b>	<b>11,848</b>	<b>11,783</b>	<b>10,393</b>	<b>11,813</b>	<b>11,673</b>	<b>11,523</b>	<b>13,821</b>
Tipping load — full turn, ISO 14397-1*	kg	4384	4390	4332	4307	4280	3750	4298	4241	4180	5029
	lb	<b>9661</b>	<b>9675</b>	<b>9546</b>	<b>9492</b>	<b>9434</b>	<b>8265</b>	<b>9472</b>	<b>9347</b>	<b>9212</b>	<b>11,083</b>
Tipping load — full turn, rigid tire**	kg	4663	4670	4608	4582	4554	3989	4572	4512	4447	5350
	lb	<b>10,278</b>	<b>10,293</b>	<b>10,156</b>	<b>10,098</b>	<b>10,036</b>	<b>8792</b>	<b>10,077</b>	<b>9943</b>	<b>9800</b>	<b>11,790</b>
Breakout force	kg	7822	8164	7466	7201	6940	6396	7635	7024	6467	5987
	lbf	<b>17,239</b>	<b>17,993</b>	<b>16,456</b>	<b>15,870</b>	<b>15,296</b>	<b>14,097</b>	<b>16,827</b>	<b>15,481</b>	<b>14,252</b>	<b>13,196</b>
Operating weight	kg	8477	8482	8521	8537	8553	8691	8504	8542	8577	8660
	lb	<b>18,684</b>	<b>18,693</b>	<b>18,780</b>	<b>18,815</b>	<b>18,850</b>	<b>19,154</b>	<b>18,742</b>	<b>18,827</b>	<b>18,903</b>	<b>19,086</b>

\*Full compliance to ISO 14397-1 (2007) Sections 1 thru 6, which requires 2% verification between calculation and testing.

\*\*Compliance to ISO 14397-1 (2007) Sections 1 thru 5.

**NOTE:** Dimensions listed are for a 914K configured with buckets, bolt-on cutting edges, optional counterweights, additional guarding, 80 kg (176 lb) operator, and Michelin 15.5 R25 (L2) XTLA tires at a pressure of 4.14 bar (60 psi) in the front tires and 2.76 bar (40 psi) in the rear tires.

Performance Data  
 ● 914K  
 ● Pallet Forks  
 ● Material Handling Arm

Wheel Loaders  
 Integrated Toolcarriers

		Pallet Forks — Standard Lift IT		Pallet Forks — High Lift IT	
Fork tine length	mm	1200		1200	
	ft/in	3'11"		3'11"	
Load center	mm	600		600	
	ft/in	1'11"		1'11"	
Overall length	mm	6706		7259	
	ft/in	22'0"		23'9"	
Ground reach	mm	637		1189	
	ft/in	2'1"		3'10"	
Digging depth	mm	51		235	
	in	2		9.2	
Level arm reach	mm	1324		1739	
	ft/in	4'4"		5'8"	
Full lift reach	mm	472		691	
	ft/in	1'6"		2'3"	
Level arm clearance	mm	1689		1689	
	ft/in	5'6"		5'6"	
Full lift clearance	mm	3485		3838	
	ft/in	11'5"		12'7"	
Overall height	mm	4472		4825	
	ft/in	14'8"		15'9"	
Tipping load — straight (ISO 14397-1)*	kg	5051		4200	
	lb	11,131		9257	
Tipping load — full turn (ISO 14397-1)*	kg	4259		3521	
	lb	9386		7759	
Operating weight	kg	8326		8380	
	lb	18,349		18,468	
Rated load (% of full turn tip): 50% of tip (SAE J1197)**	kg	2129		1760	
	lb	4693		3879	
Rated load (% of full turn tip): 60% of tip — rough terrain (EN474-3)**	kg	2555		2112	
	lb	5632		4655	
Rated load (% of full turn tip): 80% of tip — firm and level (EN474-3)**	kg	3407		2817	
	lb	7509		6207	
Minimum fork spacing	mm	300		300	
	in	11		11	
Carriage width	mm	1550		1550	
	ft/in	5'1"		5'1"	
Maximum fork spacing	mm	1526		1526	
	ft/in	5'0"		5'0"	

\*Full compliance to ISO 14397-1 (2007) Sections 1 thru 6, which requires 2% verification between calculation and testing.

\*\*Full compliance to EN474-3 and SAE J1197.

**NOTE:** Dimensions listed are for a machine configured with IT work tools, 80 kg (176 lb) operator, and standard tires.

Handling Arm Position		Material Handling Arm — Standard Lift			Material Handling Arm — High Lift		
		Retracted	Mid-position	Extended	Retracted	Mid-position	Extended
Rated load (50% of full turn tip* SAE J1197)	kg	1430	1122	925	1236	989	827
	lb	3151	2472	2037	2724	2180	1821
Operating weight	kg	8294	8294	8294	8348	8348	8348
	lb	18,280	18,280	18,280	18,399	18,399	18,399

\*Full compliance to EN474-3 and SAE J1197.

Bucket Type	General Purpose					
	Pin On					
Ground Engaging Type	Bolt-on Cutting Edges					
Rated capacity 100%	m <sup>3</sup>	1.3	1.4	1.6	1.8	1.9
	yd <sup>3</sup>	<b>1.7</b>	<b>1.8</b>	<b>2.1</b>	<b>2.4</b>	<b>2.5</b>
Rated capacity 110%	m <sup>3</sup>	1.4	1.5	1.7	1.9	2.0
	yd <sup>3</sup>	<b>1.8</b>	<b>2.0</b>	<b>2.2</b>	<b>2.5</b>	<b>2.6</b>
Struck capacity	m <sup>3</sup>	1.15	1.25	1.45	1.65	1.75
	yd <sup>3</sup>	<b>1.5</b>	<b>1.6</b>	<b>1.9</b>	<b>2.2</b>	<b>2.3</b>
Width: bucket	mm	2320	2401	2401	2401	2401
	ft/in	<b>7'7"</b>	<b>7'10"</b>	<b>7'10"</b>	<b>7'10"</b>	<b>7'10"</b>
Nominal material density, 100% fill factor	kg/m <sup>3</sup>	1982	1841	1589	1394	1312
	lb/yd <sup>3</sup>	<b>3340</b>	<b>3156</b>	<b>2668</b>	<b>2304</b>	<b>2198</b>
Nominal material density, 110% fill factor	kg/m <sup>3</sup>	1840	1718	1495	1320	1247
	lb/yd <sup>3</sup>	<b>3356</b>	<b>3021</b>	<b>2709</b>	<b>2353</b>	<b>2249</b>
Clearance: full lift, 45° dump	mm	2846	2846	2792	2738	2713
	ft/in	<b>9'4"</b>	<b>9'4"</b>	<b>9'1"</b>	<b>8'11"</b>	<b>8'10"</b>
Reach: full lift, 45° dump	mm	759	759	811	858	879
	ft/in	<b>2'5"</b>	<b>2'5"</b>	<b>2'7"</b>	<b>2'9"</b>	<b>2'10"</b>
Reach: 2130 mm (7'0") clearance, 45° dump	mm	1338	1338	1361	1377	1383
	ft/in	<b>4'4"</b>	<b>4'4"</b>	<b>4'5"</b>	<b>4'6"</b>	<b>4'6"</b>
Reach: level arm, level bucket	mm	2026	2026	2101	2175	2209
	ft/in	<b>6'7"</b>	<b>6'7"</b>	<b>6'10"</b>	<b>7'1"</b>	<b>7'2"</b>
Dig depth	mm	116	116	116	116	116
	in	<b>4.5</b>	<b>4.5</b>	<b>4.5</b>	<b>4.6</b>	<b>4.5</b>
Length: overall	mm	6226	6226	6301	6375	6409
	ft/in	<b>20'5"</b>	<b>20'5"</b>	<b>20'8"</b>	<b>20'10"</b>	<b>21'0"</b>
Height: overall	mm	4533	4534	4593	4681	4715
	ft/in	<b>14'10"</b>	<b>14'10"</b>	<b>15'0"</b>	<b>15'4"</b>	<b>15'5"</b>
Turning radius, bucket at carry	mm	5143	5180	5202	5224	5234
	ft/in	<b>16'10"</b>	<b>16'11"</b>	<b>17'0"</b>	<b>17'1"</b>	<b>17'2"</b>
Tipping load — straight, ISO 14397-1*	kg	6066	6071	5994	5922	5889
	lb	<b>13,368</b>	<b>13,380</b>	<b>13,211</b>	<b>13,051</b>	<b>12,979</b>
Tipping load — straight, rigid tire**	kg	6318	6324	6244	6169	6135
	lb	<b>13,925</b>	<b>13,938</b>	<b>13,761</b>	<b>13,595</b>	<b>13,520</b>
Tipping load — full turn, ISO 14397-1*	kg	5152	5154	5084	5017	4987
	lb	<b>11,355</b>	<b>11,360</b>	<b>11,204</b>	<b>11,057</b>	<b>10,991</b>
Tipping load — full turn, rigid tire**	kg	5481	5483	5408	5337	5306
	lb	<b>12,080</b>	<b>12,085</b>	<b>11,919</b>	<b>11,763</b>	<b>11,693</b>
Breakout force	kg	7339	7327	6691	6163	5945
	lbf	<b>16,175</b>	<b>16,148</b>	<b>14,747</b>	<b>13,583</b>	<b>13,101</b>
Operating weight	kg	7734	7754	7793	7828	7844
	lb	<b>17,046</b>	<b>17,089</b>	<b>17,175</b>	<b>17,253</b>	<b>17,288</b>

\*Full compliance to ISO 14397-1 (2007) Sections 1 thru 6, which requires 2% verification between calculation and testing.

\*\*Compliance to ISO 14397-1 (2007) Sections 1 thru 5.

**NOTE:** Dimensions listed are for a 910M configured with buckets, bolt-on cutting edges, optional counterweights, additional guarding, 80 kg (176 lb) operator, and Michelin 15.5 R25 (L2) XTLA tires at a pressure of 4.14 bar (60 psi) in the front tires and 2.76 bar (40 psi) in the rear tires.

Bucket Type	General Purpose										
	IT Quick Coupler					ISO 23727 Quick Coupler					
Ground Engaging Type	Bolt-on Cutting Edges					Bolt-on Cutting Edges					
Rated capacity 100%	m <sup>3</sup>	1.3	1.3	1.5	1.6	1.7	1.9	1.3	1.5	1.7	1.9
	yd <sup>3</sup>	<b>1.7</b>	<b>1.7</b>	<b>2.0</b>	<b>2.1</b>	<b>2.2</b>	<b>2.5</b>	<b>1.7</b>	<b>2.0</b>	<b>2.2</b>	<b>2.5</b>
Rated capacity 110%	m <sup>3</sup>	1.4	1.4	1.6	1.7	1.8	2.0	1.4	1.6	1.8	2.0
	yd <sup>3</sup>	<b>1.8</b>	<b>1.8</b>	<b>2.1</b>	<b>2.2</b>	<b>2.4</b>	<b>2.6</b>	<b>1.8</b>	<b>2.1</b>	<b>2.4</b>	<b>2.6</b>
Struck capacity	m <sup>3</sup>	1.15	1.15	1.35	1.45	1.55	1.75	1.15	1.35	1.55	1.75
	yd <sup>3</sup>	<b>1.5</b>	<b>1.5</b>	<b>1.8</b>	<b>1.9</b>	<b>2.0</b>	<b>2.3</b>	<b>1.5</b>	<b>1.8</b>	<b>2.0</b>	<b>2.3</b>
Width: bucket	mm	2320	2401	2401	2401	2401	2401	2401	2401	2401	2401
	ft/in	<b>7'7"</b>	<b>7'10"</b>	<b>7'10"</b>	<b>7'10"</b>	<b>7'10"</b>	<b>7'10"</b>	<b>7'10"</b>	<b>7'10"</b>	<b>7'10"</b>	<b>7'10"</b>
Nominal material density, 100% fill factor	kg/m <sup>3</sup>	1947	1952	1668	1554	1453	1275	1905	1628	1414	1243
	lb/yd <sup>3</sup>	<b>3281</b>	<b>3289</b>	<b>2757</b>	<b>2610</b>	<b>2474</b>	<b>2135</b>	<b>3210</b>	<b>2691</b>	<b>2408</b>	<b>2083</b>
Nominal material density, 110% fill factor	kg/m <sup>3</sup>	1808	1812	1564	1463	1372	1211	1769	1526	1335	1181
	lb/yd <sup>3</sup>	<b>3297</b>	<b>3305</b>	<b>2793</b>	<b>2650</b>	<b>2413</b>	<b>2184</b>	<b>3225</b>	<b>2726</b>	<b>2348</b>	<b>2130</b>
Clearance: full lift, 45° dump	mm	2778	2809	2747	2721	2694	2636	2772	2709	2656	2610
	ft/in	<b>9'1"</b>	<b>9'2"</b>	<b>9'0"</b>	<b>8'11"</b>	<b>8'10"</b>	<b>8'7"</b>	<b>9'1"</b>	<b>8'10"</b>	<b>8'8"</b>	<b>8'6"</b>
Reach: full lift, 45° dump	mm	843	820	867	888	910	944	863	909	952	991
	ft/in	<b>2'9"</b>	<b>2'8"</b>	<b>2'10"</b>	<b>2'10"</b>	<b>2'11"</b>	<b>3'1"</b>	<b>2'9"</b>	<b>2'11"</b>	<b>3'1"</b>	<b>3'3"</b>
Reach: 2130 mm (7'0") clearance, 45° dump	mm	1385	1380	1392	1397	1402	1398	1403	1411	1420	1428
	ft/in	<b>4'6"</b>	<b>4'6"</b>	<b>4'6"</b>	<b>4'7"</b>	<b>4'7"</b>	<b>4'7"</b>	<b>4'7"</b>	<b>4'7"</b>	<b>4'7"</b>	<b>4'8"</b>
Reach: level arm, level bucket	mm	2132	2092	2172	2207	2243	2311	2149	2228	2298	2360
	ft/in	<b>6'11"</b>	<b>6'10"</b>	<b>7'1"</b>	<b>7'2"</b>	<b>7'4"</b>	<b>7'6"</b>	<b>7'0"</b>	<b>7'3"</b>	<b>7'6"</b>	<b>7'8"</b>
Dig depth	mm	117	117	116	116	117	115	117	117	117	115
	in	<b>4.6</b>	<b>4.6</b>	<b>4.6</b>	<b>4.6</b>	<b>4.6</b>	<b>4.5</b>	<b>4.6</b>	<b>4.6</b>	<b>4.6</b>	<b>4.5</b>
Length: overall	mm	6333	6293	6373	6407	6444	6510	6350	6429	6499	6560
	ft/in	<b>20'9"</b>	<b>20'7"</b>	<b>20'10"</b>	<b>21'0"</b>	<b>21'1"</b>	<b>21'4"</b>	<b>20'10"</b>	<b>21'1"</b>	<b>21'3"</b>	<b>21'6"</b>
Height: overall	mm	4580	4563	4646	4653	4703	4783	4599	4667	4737	4817
	ft/in	<b>15'0"</b>	<b>14'11"</b>	<b>15'2"</b>	<b>15'3"</b>	<b>15'5"</b>	<b>15'8"</b>	<b>15'1"</b>	<b>15'3"</b>	<b>15'6"</b>	<b>15'9"</b>
Turning radius, bucket at carry	mm	5174	5199	5223	5234	5245	5269	5216	5239	5261	5281
	ft/in	<b>16'11"</b>	<b>17'0"</b>	<b>17'1"</b>	<b>17'2"</b>	<b>17'2"</b>	<b>17'3"</b>	<b>17'1"</b>	<b>17'2"</b>	<b>17'3"</b>	<b>17'3"</b>
Tipping load — straight, ISO 14397-1*	kg	5991	6006	5929	5896	5859	5755	5867	5792	5711	5623
	lb	<b>13,204</b>	<b>13,237</b>	<b>13,067</b>	<b>12,995</b>	<b>12,912</b>	<b>12,684</b>	<b>12,931</b>	<b>12,766</b>	<b>12,586</b>	<b>12,392</b>
Tipping load — straight, rigid tire**	kg	6241	6256	6176	6142	6103	5995	6112	6034	5949	5857
	lb	<b>13,755</b>	<b>13,789</b>	<b>13,612</b>	<b>13,536</b>	<b>13,450</b>	<b>13,213</b>	<b>13,469</b>	<b>13,298</b>	<b>13,111</b>	<b>12,909</b>
Tipping load — full turn, ISO 14397-1*	kg	5062	5074	5003	4973	4939	4845	4952	4883	4808	4725
	lb	<b>11,156</b>	<b>11,184</b>	<b>11,027</b>	<b>10,961</b>	<b>10,885</b>	<b>10,677</b>	<b>10,914</b>	<b>10,762</b>	<b>10,595</b>	<b>10,413</b>
Tipping load — full turn, rigid tire**	kg	5385	5398	5323	5291	5254	5154	5268	5195	5114	5026
	lb	<b>11,869</b>	<b>11,898</b>	<b>11,731</b>	<b>11,660</b>	<b>11,580</b>	<b>11,359</b>	<b>11,610</b>	<b>11,449</b>	<b>11,272</b>	<b>11,078</b>
Breakout force	kg	6458	6741	6158	5936	5717	5278	6298	5787	5307	5025
	lbf	<b>14,233</b>	<b>14,857</b>	<b>13,572</b>	<b>13,081</b>	<b>12,600</b>	<b>11,632</b>	<b>13,881</b>	<b>12,754</b>	<b>11,695</b>	<b>11,075</b>
Operating weight	kg	8090	8094	8133	8149	8167	8221	8116	8155	8189	8243
	lb	<b>17,829</b>	<b>17,838</b>	<b>17,925</b>	<b>17,960</b>	<b>18,000</b>	<b>18,119</b>	<b>17,888</b>	<b>17,972</b>	<b>18,048</b>	<b>18,168</b>

\*Full compliance to ISO 14397-1 (2007) Sections 1 thru 6, which requires 2% verification between calculation and testing.

\*\*Compliance to ISO 14397-1 (2007) Sections 1 thru 5.

**NOTE:** Dimensions listed are for a 910M configured with buckets, bolt-on cutting edges, optional counterweights, additional guarding, 80 kg (176 lb) operator, and Michelin 15.5 R25 (L2) XTLA tires at a pressure of 4.14 bar (60 psi) in the front tires and 2.76 bar (40 psi) in the rear tires.



Bucket Type	General Purpose					
	Pin On					
Ground Engaging Type	Bolt-on Cutting Edges					
Rated capacity 100%	m <sup>3</sup>	1.3	1.4	1.6	1.8	1.9
	yd <sup>3</sup>	<b>1.7</b>	<b>1.8</b>	<b>2.1</b>	<b>2.4</b>	<b>2.5</b>
Rated capacity 110%	m <sup>3</sup>	1.4	1.5	1.7	1.9	2.0
	yd <sup>3</sup>	<b>1.8</b>	<b>2.0</b>	<b>2.2</b>	<b>2.5</b>	<b>2.6</b>
Struck capacity	m <sup>3</sup>	1.15	1.25	1.45	1.65	1.75
	yd <sup>3</sup>	<b>1.5</b>	<b>1.6</b>	<b>1.9</b>	<b>2.2</b>	<b>2.3</b>
Width: bucket	mm	2320	2401	2401	2401	2401
	ft/in	<b>7'7"</b>	<b>7'10"</b>	<b>7'10"</b>	<b>7'10"</b>	<b>7'10"</b>
Nominal material density, 100% fill factor	kg/m <sup>3</sup>	1847	1714	1482	1302	1227
	lb/yd <sup>3</sup>	<b>3113</b>	<b>2939</b>	<b>2488</b>	<b>2152</b>	<b>2055</b>
Nominal material density, 110% fill factor	kg/m <sup>3</sup>	1715	1600	1395	1234	1166
	lb/yd <sup>3</sup>	<b>3128</b>	<b>2814</b>	<b>2527</b>	<b>2198</b>	<b>2103</b>
Clearance: full lift, 45° dump	mm	3219	3219	3171	3123	3101
	ft/in	<b>10'6"</b>	<b>10'6"</b>	<b>10'4"</b>	<b>10'2"</b>	<b>10'2"</b>
Reach: full lift, 45° dump	mm	1004	1004	1061	1118	1143
	ft/in	<b>3'3"</b>	<b>3'3"</b>	<b>3'5"</b>	<b>3'7"</b>	<b>3'9"</b>
Reach: 2130 mm (7'0") clearance, 45° dump	mm	1798	1798	1826	1848	1857
	ft/in	<b>5'10"</b>	<b>5'10"</b>	<b>5'11"</b>	<b>6'0"</b>	<b>6'1"</b>
Reach: level arm, level bucket	mm	2441	2441	2516	2590	2624
	ft/in	<b>8'0"</b>	<b>8'0"</b>	<b>8'3"</b>	<b>8'5"</b>	<b>8'7"</b>
Dig depth	mm	294	294	294	294	294
	in	<b>11.6</b>	<b>11.6</b>	<b>11.6</b>	<b>11.6</b>	<b>11.6</b>
Length: overall	mm	6758	6758	6834	6907	6941
	ft/in	<b>22'2"</b>	<b>22'2"</b>	<b>22'5"</b>	<b>22'7"</b>	<b>22'9"</b>
Height: overall	mm	4889	4891	4949	5037	5071
	ft/in	<b>16'0"</b>	<b>16'0"</b>	<b>16'2"</b>	<b>16'6"</b>	<b>16'7"</b>
Turning radius, bucket at carry	mm	5384	5419	5443	5466	5476
	ft/in	<b>17'7"</b>	<b>17'9"</b>	<b>17'10"</b>	<b>17'11"</b>	<b>17'11"</b>
Tipping load — straight, ISO 14397-1*	kg	5705	5706	5643	5585	5558
	lb	<b>12,573</b>	<b>12,575</b>	<b>12,438</b>	<b>12,309</b>	<b>12,250</b>
Tipping load — straight, rigid tire**	kg	5943	5944	5879	5818	5790
	lb	<b>13,097</b>	<b>13,099</b>	<b>12,956</b>	<b>12,821</b>	<b>12,761</b>
Tipping load — full turn, ISO 14397-1*	kg	4802	4800	4742	4688	4663
	lb	<b>10,584</b>	<b>10,579</b>	<b>10,451</b>	<b>10,331</b>	<b>10,277</b>
Tipping load — full turn, rigid tire**	kg	5109	5107	5045	4987	4961
	lb	<b>11,259</b>	<b>11,255</b>	<b>11,118</b>	<b>10,991</b>	<b>10,933</b>
Breakout force	kg	7404	7392	6751	6218	5998
	lbf	<b>16,319</b>	<b>16,291</b>	<b>14,879</b>	<b>13,705</b>	<b>13,220</b>
Operating weight	kg	8299	8318	8357	8392	8408
	lb	<b>18,289</b>	<b>18,333</b>	<b>18,418</b>	<b>18,496</b>	<b>18,531</b>

\*Full compliance to ISO 14397-1 (2007) Sections 1 thru 6, which requires 2% verification between calculation and testing.

\*\*Compliance to ISO 14397-1 (2007) Sections 1 thru 5.

**NOTE:** Dimensions listed are for a 910M configured with buckets, bolt-on cutting edges, optional counterweights, additional guarding, 80 kg (176 lb) operator, and Michelin 15.5 R25 (L2) XTLA tires at a pressure of 4.14 bar (60 psi) in the front tires and 2.76 bar (40 psi) in the rear tires.

Bucket Type	General Purpose										
	IT Quick Coupler						ISO 23727 Quick Coupler				
Ground Engaging Type	Bolt-on Cutting Edges						Bolt-on Cutting Edges				
Rated capacity 100%	m <sup>3</sup>	1.3	1.3	1.5	1.6	1.7	1.9	1.3	1.5	1.7	1.9
	yd <sup>3</sup>	1.7	1.7	2.0	2.1	2.2	2.5	1.7	2.0	2.2	2.5
Rated capacity 110%	m <sup>3</sup>	1.4	1.4	1.6	1.7	1.8	2.0	1.4	1.6	1.8	2.0
	yd <sup>3</sup>	1.8	1.8	2.1	2.2	2.4	2.6	1.8	2.1	2.4	2.6
Struck capacity	m <sup>3</sup>	1.15	1.15	1.35	1.45	1.55	1.75	1.15	1.35	1.55	1.75
	yd <sup>3</sup>	1.5	1.5	1.8	1.9	2.0	2.3	1.5	1.8	2.0	2.3
Width: bucket	mm	2320	2401	2401	2401	2401	2401	2401	2401	2401	2401
	ft/in	7'7"	7'10"	7'10"	7'10"	7'10"	7'10"	7'10"	7'10"	7'10"	7'10"
Nominal material density, 100% fill factor	kg/m <sup>3</sup>	1811	1814	1552	1447	1354	1190	1777	1521	1324	1165
	lb/yd <sup>3</sup>	3052	3056	2566	2430	2306	1994	2994	2514	2255	1951
Nominal material density, 110% fill factor	kg/m <sup>3</sup>	1682	1684	1455	1362	1279	1131	1650	1426	1250	1107
	lb/yd <sup>3</sup>	3067	3071	2600	2468	2249	2040	3009	2547	2199	1996
Clearance: full lift, 45° dump	mm	3151	3176	3125	3102	3079	3026	3140	3090	3044	3004
	ft/in	10'4"	10'5"	10'3"	10'2"	10'1"	9'11"	10'3"	10'1"	9'11"	9'10"
Reach: full lift, 45° dump	mm	1084	1054	1115	1142	1169	1208	1100	1160	1214	1259
	ft/in	3'6"	3'5"	3'7"	3'8"	3'10"	3'11"	3'7"	3'9"	3'11"	4'1"
Reach: 2130 mm (7'0") clearance, 45° dump	mm	1852	1843	1861	1870	1878	1881	1869	1884	1900	1915
	ft/in	6'0"	6'0"	6'1"	6'1"	6'1"	6'2"	6'1"	6'2"	6'2"	6'3"
Reach: level arm, level bucket	mm	2546	2507	2587	2621	2657	2725	2564	2643	2713	2775
	ft/in	8'4"	8'2"	8'5"	8'7"	8'8"	8'11"	8'4"	8'8"	8'10"	9'1"
Dig depth	mm	295	295	295	295	295	294	295	295	295	293
	in	11.6	11.6	11.6	11.6	11.6	11.6	11.6	11.6	11.6	11.6
Length: overall	mm	6865	6825	6905	6939	6976	7043	6882	6961	7031	7092
	ft/in	22'6"	22'4"	22'7"	22'9"	22'10"	23'1"	22'6"	22'10"	23'0"	23'3"
Height: overall	mm	4937	4920	5002	5009	5059	5140	4955	5023	5094	5174
	ft/in	16'2"	16'1"	16'4"	16'5"	16'7"	16'10"	16'3"	16'5"	16'8"	16'11"
Turning radius, bucket at carry	mm	5417	5440	5465	5476	5487	5514	5452	5478	5500	5521
	ft/in	17'9"	17'10"	17'11"	17'11"	18'0"	18'1"	17'10"	17'11"	18'0"	18'1"
Tipping load — straight, ISO 14397-1*	kg	5625	5633	5570	5543	5513	5426	5524	5463	5398	5320
	lb	12,397	12,415	12,276	12,217	12,150	11,958	12,175	12,039	11,896	11,724
Tipping load — straight, rigid tire**	kg	5859	5868	5802	5774	5742	5652	5754	5690	5623	5541
	lb	12,913	12,932	12,788	12,726	12,656	12,457	12,682	12,541	12,392	12,212
Tipping load — full turn, ISO 14397-1*	kg	4709	4715	4657	4632	4603	4524	4619	4562	4501	4427
	lb	10,378	10,392	10,263	10,208	10,145	9970	10,181	10,055	9920	9757
Tipping load — full turn, rigid tire**	kg	5010	5016	4954	4928	4897	4812	4914	4853	4788	4710
	lb	11,040	11,056	10,918	10,860	10,793	10,606	10,831	10,697	10,553	10,379
Breakout force	kg	6514	6800	6212	5988	5768	5343	6351	5836	5353	5073
	lbf	14,357	14,987	13,692	13,198	12,711	11,774	13,998	12,862	11,797	11,180
Operating weight	kg	8654	8658	8698	8713	8731	8785	8680	8719	8753	8807
	lb	19,073	19,082	19,169	19,204	19,243	19,362	19,131	19,216	19,291	19,411

\*Full compliance to ISO 14397-1 (2007) Sections 1 thru 6, which requires 2% verification between calculation and testing.

\*\*Compliance to ISO 14397-1 (2007) Sections 1 thru 5.

**NOTE:** Dimensions listed are for a 910M configured with buckets, bolt-on cutting edges, optional counterweights, additional guarding, 80 kg (176 lb) operator, and Michelin 15.5 R25 (L2) XTLA tires at a pressure of 4.14 bar (60 psi) in the front tires and 2.76 bar (40 psi) in the rear tires.

# Wheel Loaders Integrated Toolcarriers

## Performance Data

- 910M
- Pallet Forks
- Material Handling Arm

		Pallet Forks — Standard Lift IT	Pallet Forks — High Lift IT
Fork tine length	mm	1200	1200
	ft/in	3'11"	3'11"
Load center	mm	600	600
	ft/in	1'11"	1'11"
Overall length	mm	6719	7259
	ft/in	22'0"	23'9"
Ground reach	mm	693	1233
	ft/in	2'3"	4'0"
Digging depth	mm	78	256
	in	3.1	10.1
Level arm reach	mm	1354	1769
	ft/in	4'5"	5'9"
Full lift reach	mm	502	722
	ft/in	1'7"	2'4"
Level arm clearance	mm	1640	1640
	ft/in	5'4"	5'4"
Full lift clearance	mm	3457	3813
	ft/in	11'4"	12'6"
Overall height	mm	4443	4800
	ft/in	14'6"	15'8"
Tipping load — straight (ISO 14397-1)*	kg	4637	4480
	lb	10,221	9873
Tipping load — full turn (ISO 14397-1)*	kg	3926	3758
	lb	8652	8282
Operating weight	kg	7992	8556
	lb	17,614	18,857
Rated load (% of full turn tip): 50% of tip (SAE J1197)**	kg	1963	1879
	lb	4326	4141
Rated load (% of full turn tip): 60% of tip — rough terrain (EN474-3)**	kg	2355	2255
	lb	5191	4969
Rated load (% of full turn tip): 80% of tip — firm and level (EN474-3)**	kg	3141	3007
	lb	6921	6626
Minimum fork spacing	mm	300	300
	in	11	11
Carriage width	mm	1550	1550
	ft/in	5'1"	5'1"
Maximum fork spacing	mm	1526	1526
	ft/in	5'0"	5'0"

\*Full compliance to ISO 14397-1 (2007) Sections 1 thru 6, which requires 2% verification between calculation and testing.

\*\*Full compliance to EN474-3 and SAE J1197.

**NOTE:** Dimensions listed are for a machine configured with IT work tools, optional counterweights, additional guarding, 80 kg (176 lb) operator, and Michelin 175 R25 L2 XTLA tires.

Handling Arm Position		Material Handling Arm — Standard Lift		
		Retracted	Mid-position	Extended
Rated load (50% of full turn tip* SAE J1197)	kg	1313	1028	847
	lb	2893	2266	1865
Operating weight	kg	7960	7960	7960
	lb	17,544	17,544	17,544

\*Full compliance to EN474-3 and SAE J1197.

Bucket Type	General Purpose					
	Pin On					
Ground Engaging Type	Bolt-on Cutting Edges					
Rated capacity 100%	m <sup>3</sup>	1.3	1.4	1.6	1.8	1.9
	yd <sup>3</sup>	<b>1.7</b>	<b>1.8</b>	<b>2.1</b>	<b>2.4</b>	<b>2.5</b>
Rated capacity 110%	m <sup>3</sup>	1.4	1.5	1.7	1.9	2.0
	yd <sup>3</sup>	<b>1.8</b>	<b>2.0</b>	<b>2.2</b>	<b>2.5</b>	<b>2.6</b>
Struck capacity	m <sup>3</sup>	1.25	1.15	1.45	1.65	1.75
	yd <sup>3</sup>	<b>1.6</b>	<b>1.5</b>	<b>1.9</b>	<b>2.2</b>	<b>2.3</b>
Width: bucket	mm	2320	2401	2401	2401	2401
	ft/in	<b>7'7"</b>	<b>7'10"</b>	<b>7'10"</b>	<b>7'10"</b>	<b>7'10"</b>
Nominal material density, 100% fill factor	kg/m <sup>3</sup>	2129	1978	1708	1499	1412
	lb/yd <sup>3</sup>	<b>3589</b>	<b>3391</b>	<b>2868</b>	<b>2477</b>	<b>2364</b>
Nominal material density, 110% fill factor	kg/m <sup>3</sup>	1977	1846	1607	1420	1341
	lb/yd <sup>3</sup>	<b>3606</b>	<b>3247</b>	<b>2912</b>	<b>2530</b>	<b>2418</b>
Clearance: full lift, 45° dump	mm	2874	2874	2820	2766	2741
	ft/in	<b>9'5"</b>	<b>9'5"</b>	<b>9'3"</b>	<b>9'0"</b>	<b>8'11"</b>
Reach: full lift, 45° dump	mm	737	737	790	838	860
	ft/in	<b>2'5"</b>	<b>2'5"</b>	<b>2'7"</b>	<b>2'8"</b>	<b>2'9"</b>
Reach: 2130 mm (7'0") clearance, 45° dump	mm	1327	1327	1352	1370	1377
	ft/in	<b>4'4"</b>	<b>4'4"</b>	<b>4'5"</b>	<b>4'5"</b>	<b>4'6"</b>
Reach: level arm, level bucket	mm	1996	1996	2072	2146	2179
	ft/in	<b>6'6"</b>	<b>6'6"</b>	<b>6'9"</b>	<b>7'0"</b>	<b>7'1"</b>
Dig depth	mm	89	89	89	89	89
	in	<b>3.5</b>	<b>3.5</b>	<b>3.5</b>	<b>3.5</b>	<b>3.5</b>
Length: overall	mm	6215	6215	6291	6364	6398
	ft/in	<b>20'4"</b>	<b>20'4"</b>	<b>20'7"</b>	<b>20'10"</b>	<b>20'11"</b>
Height: overall	mm	4561	4562	4621	4709	4743
	ft/in	<b>14'11"</b>	<b>14'11"</b>	<b>15'1"</b>	<b>15'5"</b>	<b>15'6"</b>
Turning radius, bucket at carry	mm	5140	5178	5200	5223	5233
	ft/in	<b>16'10"</b>	<b>16'11"</b>	<b>17'0"</b>	<b>17'1"</b>	<b>17'2"</b>
Tipping load — straight, ISO 14397-1*	kg	6539	6546	6464	6388	6354
	lb	<b>14,411</b>	<b>14,426</b>	<b>14,247</b>	<b>14,079</b>	<b>14,003</b>
Tipping load — straight, rigid tire**	kg	6811	6818	6734	6654	6618
	lb	<b>15,011</b>	<b>15,027</b>	<b>14,841</b>	<b>14,666</b>	<b>14,587</b>
Tipping load — full turn, ISO 14397-1*	kg	5536	5539	5465	5395	5364
	lb	<b>12,201</b>	<b>12,208</b>	<b>12,045</b>	<b>11,891</b>	<b>11,822</b>
Tipping load — full turn, rigid tire**	kg	5890	5893	5814	5740	5706
	lb	<b>12,980</b>	<b>12,987</b>	<b>12,813</b>	<b>12,650</b>	<b>12,576</b>
Breakout force	kg	8743	8730	7981	7358	7101
	lbf	<b>19,269</b>	<b>19,241</b>	<b>17,589</b>	<b>16,217</b>	<b>15,649</b>
Operating weight	kg	8341	8360	8399	8435	8451
	lb	<b>18,383</b>	<b>18,426</b>	<b>18,512</b>	<b>18,590</b>	<b>18,625</b>

\*Full compliance to ISO 14397-1 (2007) Sections 1 thru 6, which requires 2% verification between calculation and testing.

\*\*Compliance to ISO 14397-1 (2007) Sections 1 thru 5.

**NOTE:** Dimensions listed are for a 914M configured with buckets, bolt-on cutting edges, optional counterweights, additional guarding, 80 kg (176 lb) operator, and Michelin 15.5 R25 (L2) XTLA tires at a pressure of 4.14 bar (60 psi) in the front tires and 2.76 bar (40 psi) in the rear tires.

Bucket Type	General Purpose										
	IT Quick Coupler						ISO 23727 Quick Coupler				
Ground Engaging Type	Bolt-on Cutting Edges						Bolt-on Cutting Edges				
Rated capacity 100%	m <sup>3</sup>	1.3	1.3	1.5	1.6	1.7	1.9	1.3	1.5	1.7	1.9
	yd <sup>3</sup>	<b>1.7</b>	<b>1.7</b>	<b>2.0</b>	<b>2.1</b>	<b>2.2</b>	<b>2.5</b>	<b>1.7</b>	<b>2.0</b>	<b>2.2</b>	<b>2.5</b>
Rated capacity 110%	m <sup>3</sup>	1.4	1.4	1.6	1.7	1.8	2.0	1.4	1.6	1.8	2.0
	yd <sup>3</sup>	<b>1.8</b>	<b>1.8</b>	<b>2.1</b>	<b>2.2</b>	<b>2.4</b>	<b>2.6</b>	<b>1.8</b>	<b>2.1</b>	<b>2.4</b>	<b>2.6</b>
Struck capacity	m <sup>3</sup>	1.15	1.15	1.35	1.45	1.55	1.75	1.15	1.35	1.55	1.75
	yd <sup>3</sup>	<b>1.5</b>	<b>1.5</b>	<b>1.8</b>	<b>1.9</b>	<b>2.0</b>	<b>2.3</b>	<b>1.5</b>	<b>1.8</b>	<b>2.0</b>	<b>2.3</b>
Width: bucket	mm	2320	2401	2401	2401	2401	2401	2401	2401	2401	2401
	ft/in	<b>7'7"</b>	<b>7'10"</b>	<b>7'10"</b>	<b>7'10"</b>	<b>7'10"</b>	<b>7'10"</b>	<b>7'10"</b>	<b>7'10"</b>	<b>7'10"</b>	<b>7'10"</b>
Nominal material density, 100% fill factor	kg/m <sup>3</sup>	2090	2096	1791	1670	1561	1371	2046	1749	1520	1338
	lb/yd <sup>3</sup>	<b>3523</b>	<b>3532</b>	<b>2961</b>	<b>2804</b>	<b>2658</b>	<b>2296</b>	<b>3448</b>	<b>2891</b>	<b>2589</b>	<b>2241</b>
Nominal material density, 110% fill factor	kg/m <sup>3</sup>	1941	1946	1679	1571	1474	1302	1900	1640	1436	1271
	lb/yd <sup>3</sup>	<b>3539</b>	<b>3549</b>	<b>3000</b>	<b>2847</b>	<b>2592</b>	<b>2348</b>	<b>3464</b>	<b>2929</b>	<b>2525</b>	<b>2292</b>
Clearance: full lift, 45° dump	mm	2806	2838	2775	2749	2722	2664	2800	2738	2684	2638
	ft/in	<b>9'2"</b>	<b>9'3"</b>	<b>9'1"</b>	<b>9'0"</b>	<b>8'11"</b>	<b>8'8"</b>	<b>9'2"</b>	<b>8'11"</b>	<b>8'9"</b>	<b>8'7"</b>
Reach: full lift, 45° dump	mm	822	799	847	868	891	925	843	889	933	973
	ft/in	<b>2'8"</b>	<b>2'7"</b>	<b>2'9"</b>	<b>2'10"</b>	<b>2'11"</b>	<b>3'0"</b>	<b>2'9"</b>	<b>2'10"</b>	<b>3'0"</b>	<b>3'2"</b>
Reach: 2130 mm (7'0") clearance, 45° dump	mm	1377	1370	1384	1390	1396	1394	1394	1404	1415	1425
	ft/in	<b>4'6"</b>	<b>4'5"</b>	<b>4'6"</b>	<b>4'6"</b>	<b>4'6"</b>	<b>4'6"</b>	<b>4'6"</b>	<b>4'7"</b>	<b>4'7"</b>	<b>4'8"</b>
Reach: level arm, level bucket	mm	2102	2063	2143	2177	2213	2281	2120	2199	2269	2331
	ft/in	<b>6'10"</b>	<b>6'9"</b>	<b>7'0"</b>	<b>7'1"</b>	<b>7'3"</b>	<b>7'5"</b>	<b>6'11"</b>	<b>7'2"</b>	<b>7'5"</b>	<b>7'7"</b>
Dig depth	mm	90	90	89	89	90	88	90	90	90	88
	in	<b>3.5</b>	<b>3.5</b>	<b>3.5</b>	<b>3.5</b>	<b>3.5</b>	<b>3.5</b>	<b>3.5</b>	<b>3.5</b>	<b>3.5</b>	<b>3.5</b>
Length: overall	mm	6322	6282	6362	6397	6433	6500	6340	6419	6489	6549
	ft/in	<b>20'8"</b>	<b>20'7"</b>	<b>20'10"</b>	<b>20'11"</b>	<b>21'1"</b>	<b>21'3"</b>	<b>20'9"</b>	<b>21'0"</b>	<b>21'3"</b>	<b>21'5"</b>
Height: overall	mm	4608	4591	4674	4681	4731	4811	4627	4695	4765	4845
	ft/in	<b>15'1"</b>	<b>15'0"</b>	<b>15'4"</b>	<b>15'4"</b>	<b>15'6"</b>	<b>15'9"</b>	<b>15'2"</b>	<b>15'4"</b>	<b>15'7"</b>	<b>15'10"</b>
Turning radius, bucket at carry	mm	5172	5198	5222	5232	5244	5268	5216	5240	5262	5282
	ft/in	<b>16'11"</b>	<b>17'0"</b>	<b>17'1"</b>	<b>17'2"</b>	<b>17'2"</b>	<b>17'3"</b>	<b>17'1"</b>	<b>17'2"</b>	<b>17'3"</b>	<b>17'3"</b>
Tipping load — straight, ISO 14397-1*	kg	6451	6468	6387	6352	6313	6204	6321	6242	6157	6066
	lb	<b>14,218</b>	<b>14,255</b>	<b>14,076</b>	<b>14,000</b>	<b>13,913</b>	<b>13,674</b>	<b>13,930</b>	<b>13,757</b>	<b>13,569</b>	<b>13,369</b>
Tipping load — straight, rigid tire**	kg	6720	6738	6653	6617	6576	6463	6584	6502	6413	6319
	lb	<b>14,810</b>	<b>14,849</b>	<b>14,663</b>	<b>14,583</b>	<b>14,493</b>	<b>14,243</b>	<b>14,511</b>	<b>14,330</b>	<b>14,134</b>	<b>13,926</b>
Tipping load — full turn, ISO 14397-1*	kg	5435	5449	5374	5343	5307	5208	5320	5247	5168	5084
	lb	<b>11,978</b>	<b>12,009</b>	<b>11,845</b>	<b>11,775</b>	<b>11,696</b>	<b>11,478</b>	<b>11,724</b>	<b>11,565</b>	<b>11,391</b>	<b>11,204</b>
Tipping load — full turn, rigid tire**	kg	5782	5797	5717	5684	5646	5541	5659	5582	5498	5408
	lb	<b>12,742</b>	<b>12,775</b>	<b>12,601</b>	<b>12,526</b>	<b>12,442</b>	<b>12,211</b>	<b>12,472</b>	<b>12,303</b>	<b>12,118</b>	<b>11,919</b>
Breakout force	kg	7708	8045	7357	7095	6837	6322	7527	6924	6372	6034
	lbf	<b>16,987</b>	<b>17,730</b>	<b>16,214</b>	<b>15,636</b>	<b>15,069</b>	<b>13,933</b>	<b>16,589</b>	<b>15,259</b>	<b>14,044</b>	<b>13,298</b>
Operating weight	kg	8696	8700	8740	8756	8774	8827	8723	8761	8795	8850
	lb	<b>19,166</b>	<b>19,175</b>	<b>19,262</b>	<b>19,297</b>	<b>19,337</b>	<b>19,455</b>	<b>19,224</b>	<b>19,309</b>	<b>19,385</b>	<b>19,504</b>

\*Full compliance to ISO 14397-1 (2007) Sections 1 thru 6, which requires 2% verification between calculation and testing.

\*\*Compliance to ISO 14397-1 (2007) Sections 1 thru 5.

**NOTE:** Dimensions listed are for a 914M configured with buckets, bolt-on cutting edges, optional counterweights, additional guarding, 80 kg (176 lb) operator, and Michelin 15.5 R25 (L2) XTLA tires at a pressure of 4.14 bar (60 psi) in the front tires and 2.76 bar (40 psi) in the rear tires.

Bucket Type	General Purpose					
	Pin On					
Ground Engaging Type	Bolt-on Cutting Edges					
Rated capacity 100%	m <sup>3</sup>	1.3	1.4	1.6	1.5	1.9
	yd <sup>3</sup>	<b>1.7</b>	<b>1.8</b>	<b>2.1</b>	<b>2.0</b>	<b>2.5</b>
Rated capacity 110%	m <sup>3</sup>	1.4	1.5	1.7	1.6	2.0
	yd <sup>3</sup>	<b>1.8</b>	<b>2.0</b>	<b>2.2</b>	<b>2.1</b>	<b>2.6</b>
Struck capacity	m <sup>3</sup>	1.25	1.15	1.45	1.65	1.75
	yd <sup>3</sup>	<b>1.6</b>	<b>1.5</b>	<b>1.9</b>	<b>2.2</b>	<b>2.3</b>
Width: bucket	mm	2320	2401	2401	2401	2401
	ft/in	<b>7'7"</b>	<b>7'10"</b>	<b>7'10"</b>	<b>7'10"</b>	<b>7'10"</b>
Nominal material density, 100% fill factor	kg/m <sup>3</sup>	1947	1807	1562	1648	1294
	lb/yd <sup>3</sup>	<b>3281</b>	<b>3098</b>	<b>2623</b>	<b>2724</b>	<b>2168</b>
Nominal material density, 110% fill factor	kg/m <sup>3</sup>	1808	1687	1470	1545	1229
	lb/yd <sup>3</sup>	<b>3296</b>	<b>2966</b>	<b>2664</b>	<b>2759</b>	<b>2217</b>
Clearance: full lift, 45° dump	mm	3237	3237	3188	3139	3117
	ft/in	<b>10'7"</b>	<b>10'7"</b>	<b>10'5"</b>	<b>10'3"</b>	<b>10'2"</b>
Reach: full lift, 45° dump	mm	971	971	1029	1085	1111
	ft/in	<b>3'2"</b>	<b>3'2"</b>	<b>3'4"</b>	<b>3'6"</b>	<b>3'7"</b>
Reach: 2130 mm (7'0") clearance, 45° dump	mm	1782	1782	1812	1835	1845
	ft/in	<b>5'10"</b>	<b>5'10"</b>	<b>5'11"</b>	<b>6'0"</b>	<b>6'0"</b>
Reach: level arm, level bucket	mm	2411	2411	2487	2560	2594
	ft/in	<b>7'10"</b>	<b>7'10"</b>	<b>8'1"</b>	<b>8'4"</b>	<b>8'6"</b>
Dig depth	mm	272	272	272	272	272
	in	<b>10.7</b>	<b>10.7</b>	<b>10.7</b>	<b>10.7</b>	<b>10.7</b>
Length: overall	mm	6758	6758	6834	6908	6941
	ft/in	<b>22'2"</b>	<b>22'2"</b>	<b>22'5"</b>	<b>22'7"</b>	<b>22'9"</b>
Height: overall	mm	4914	4916	4974	5062	5096
	ft/in	<b>16'1"</b>	<b>16'1"</b>	<b>16'3"</b>	<b>16'7"</b>	<b>16'8"</b>
Turning radius, bucket at carry	mm	5388	5424	5448	5471	5482
	ft/in	<b>17'8"</b>	<b>17'9"</b>	<b>17'10"</b>	<b>17'11"</b>	<b>17'11"</b>
Tipping load — straight, ISO 14397-1*	kg	6023	6025	5960	5899	5872
	lb	<b>13,275</b>	<b>13,278</b>	<b>13,135</b>	<b>13,001</b>	<b>12,940</b>
Tipping load — straight, rigid tire**	kg	6274	6276	6208	6145	6116
	lb	<b>13,828</b>	<b>13,832</b>	<b>13,683</b>	<b>13,543</b>	<b>13,479</b>
Tipping load — full turn, ISO 14397-1*	kg	5061	5060	4999	4943	4917
	lb	<b>11,154</b>	<b>11,151</b>	<b>11,018</b>	<b>10,894</b>	<b>10,838</b>
Tipping load — full turn, rigid tire**	kg	5384	5383	5319	5258	5231
	lb	<b>11,866</b>	<b>11,863</b>	<b>11,722</b>	<b>11,589</b>	<b>11,529</b>
Breakout force	kg	8873	8861	8100	7469	7208
	lbf	<b>19,555</b>	<b>19,528</b>	<b>17,853</b>	<b>16,460</b>	<b>15,886</b>
Operating weight	kg	8867	8887	8926	8961	8977
	lb	<b>19,542</b>	<b>19,586</b>	<b>19,671</b>	<b>19,749</b>	<b>19,784</b>

\*Full compliance to ISO 14397-1 (2007) Sections 1 thru 6, which requires 2% verification between calculation and testing.

\*\*Compliance to ISO 14397-1 (2007) Sections 1 thru 5.

**NOTE:** Dimensions listed are for a 914M configured with buckets, bolt-on cutting edges, optional counterweights, additional guarding, 80 kg (176 lb) operator, and Michelin 15.5 R25 (L2) XTLA tires at a pressure of 4.14 bar (60 psi) in the front tires and 2.76 bar (40 psi) in the rear tires.

# Wheel Loaders Integrated Toolcarriers

## Performance Data ● 914M High Lift

Bucket Type	General Purpose										
	IT Quick Coupler						ISO 23727 Quick Coupler				
Ground Engaging Type	Bolt-on Cutting Edges						Bolt-on Cutting Edges				
Rated capacity 100%	m <sup>3</sup>	1.3	1.3	1.5	1.6	1.7	1.9	1.3	1.5	1.7	1.9
	yd <sup>3</sup>	<b>1.7</b>	<b>1.7</b>	<b>2.0</b>	<b>2.1</b>	<b>2.2</b>	<b>2.5</b>	<b>1.7</b>	<b>2.0</b>	<b>2.2</b>	<b>2.5</b>
Rated capacity 110%	m <sup>3</sup>	1.4	1.4	1.6	1.7	1.8	2.0	1.4	1.6	1.8	2.0
	yd <sup>3</sup>	<b>1.8</b>	<b>1.8</b>	<b>2.1</b>	<b>2.2</b>	<b>2.4</b>	<b>2.6</b>	<b>1.8</b>	<b>2.1</b>	<b>2.4</b>	<b>2.6</b>
Struck capacity	m <sup>3</sup>	1.15	1.15	1.35	1.45	1.55	1.75	1.15	1.35	1.55	1.75
	yd <sup>3</sup>	<b>1.5</b>	<b>1.5</b>	<b>1.8</b>	<b>1.9</b>	<b>2.0</b>	<b>2.3</b>	<b>1.5</b>	<b>1.8</b>	<b>2.0</b>	<b>2.3</b>
Width: bucket	mm	2320	2401	2401	2401	2401	2401	2401	2401	2401	2401
	ft/in	<b>7'7"</b>	<b>7'10"</b>	<b>7'10"</b>	<b>7'10"</b>	<b>7'10"</b>	<b>7'10"</b>	<b>7'10"</b>	<b>7'10"</b>	<b>7'10"</b>	<b>7'10"</b>
Nominal material density, 100% fill factor	kg/m <sup>3</sup>	1837	1839	1574	1468	1373	1207	1802	1542	1342	1181
	lb/yd <sup>3</sup>	<b>3095</b>	<b>3100</b>	<b>2602</b>	<b>2465</b>	<b>2338</b>	<b>2022</b>	<b>3037</b>	<b>2549</b>	<b>2286</b>	<b>1979</b>
Nominal material density, 110% fill factor	kg/m <sup>3</sup>	1705	1708	1476	1381	1297	1147	1673	1446	1268	1122
	lb/yd <sup>3</sup>	<b>3110</b>	<b>3114</b>	<b>2636</b>	<b>2503</b>	<b>2280</b>	<b>2068</b>	<b>3051</b>	<b>2583</b>	<b>2229</b>	<b>2024</b>
Clearance: full lift, 45° dump	mm	3167	3193	3141	3118	3094	3041	3157	3105	3059	3018
	ft/in	<b>10'4"</b>	<b>10'5"</b>	<b>10'3"</b>	<b>10'2"</b>	<b>10'1"</b>	<b>9'11"</b>	<b>10'4"</b>	<b>10'2"</b>	<b>10'0"</b>	<b>9'10"</b>
Reach: full lift, 45° dump	mm	1051	1021	1083	1109	1137	1176	1067	1127	1181	1227
	ft/in	<b>3'5"</b>	<b>3'4"</b>	<b>3'6"</b>	<b>3'7"</b>	<b>3'8"</b>	<b>3'10"</b>	<b>3'6"</b>	<b>3'8"</b>	<b>3'10"</b>	<b>4'0"</b>
Reach: 2130 mm (7'0") clearance, 45° dump	mm	1838	1829	1848	1857	1866	1871	1856	1872	1889	1905
	ft/in	<b>6'0"</b>	<b>5'11"</b>	<b>6'0"</b>	<b>6'1"</b>	<b>6'1"</b>	<b>6'1"</b>	<b>6'1"</b>	<b>6'1"</b>	<b>6'2"</b>	<b>6'2"</b>
Reach: level arm, level bucket	mm	2517	2477	2558	2592	2628	2696	2535	2614	2684	2746
	ft/in	<b>8'3"</b>	<b>8'1"</b>	<b>8'4"</b>	<b>8'6"</b>	<b>8'7"</b>	<b>8'10"</b>	<b>8'3"</b>	<b>8'6"</b>	<b>8'9"</b>	<b>9'0"</b>
Dig depth	mm	274	274	273	273	273	272	273	273	273	272
	in	<b>10.8</b>	<b>10.8</b>	<b>10.8</b>	<b>10.8</b>	<b>10.8</b>	<b>10.7</b>	<b>10.8</b>	<b>10.8</b>	<b>10.8</b>	<b>10.7</b>
Length: overall	mm	6865	6825	6905	6940	6976	7043	6883	6962	7032	7093
	ft/in	<b>22'6"</b>	<b>22'4"</b>	<b>22'7"</b>	<b>22'9"</b>	<b>22'10"</b>	<b>23'1"</b>	<b>22'6"</b>	<b>22'10"</b>	<b>23'0"</b>	<b>23'3"</b>
Height: overall	mm	4962	4945	5027	5034	5084	5165	4980	5048	5119	5199
	ft/in	<b>16'3"</b>	<b>16'2"</b>	<b>16'5"</b>	<b>16'6"</b>	<b>16'8"</b>	<b>16'11"</b>	<b>16'4"</b>	<b>16'6"</b>	<b>16'9"</b>	<b>17'0"</b>
Turning radius, bucket at carry	mm	5422	5445	5471	5482	5494	5521	5458	5484	5507	5528
	ft/in	<b>17'9"</b>	<b>17'10"</b>	<b>17'11"</b>	<b>17'11"</b>	<b>18'0"</b>	<b>18'1"</b>	<b>17'10"</b>	<b>17'11"</b>	<b>18'0"</b>	<b>18'1"</b>
Tipping load — straight, ISO 14397-1*	kg	5712	5721	5656	5629	5597	5509	5610	5547	5480	5401
	lb	<b>12,588</b>	<b>12,608</b>	<b>12,465</b>	<b>12,405</b>	<b>12,336</b>	<b>12,141</b>	<b>12,364</b>	<b>12,225</b>	<b>12,078</b>	<b>11,904</b>
Tipping load — straight, rigid tire**	kg	5950	5959	5892	5863	5831	5738	5844	5778	5708	5626
	lb	<b>13,113</b>	<b>13,133</b>	<b>12,985</b>	<b>12,922</b>	<b>12,850</b>	<b>12,647</b>	<b>12,879</b>	<b>12,734</b>	<b>12,581</b>	<b>12,400</b>
Tipping load — full turn, ISO 14397-1*	kg	4775	4782	4722	4697	4668	4587	4685	4626	4564	4489
	lb	<b>10,524</b>	<b>10,539</b>	<b>10,407</b>	<b>10,351</b>	<b>10,287</b>	<b>10,108</b>	<b>10,325</b>	<b>10,196</b>	<b>10,058</b>	<b>9893</b>
Tipping load — full turn, rigid tire**	kg	5080	5087	5024	4997	4966	4879	4984	4922	4855	4776
	lb	<b>11,195</b>	<b>11,212</b>	<b>11,071</b>	<b>11,012</b>	<b>10,944</b>	<b>10,754</b>	<b>10,984</b>	<b>10,847</b>	<b>10,700</b>	<b>10,525</b>
Breakout force	kg	7822	8164	7466	7201	6939	6441	7635	7024	6467	6128
	lbf	<b>17,239</b>	<b>17,993</b>	<b>16,456</b>	<b>15,870</b>	<b>15,294</b>	<b>14,195</b>	<b>16,827</b>	<b>15,481</b>	<b>14,252</b>	<b>13,506</b>
Operating weight	kg	9070	9074	9114	9130	9148	9202	9097	9135	9170	9224
	lb	<b>19,991</b>	<b>20,000</b>	<b>20,087</b>	<b>20,122</b>	<b>20,161</b>	<b>20,280</b>	<b>20,049</b>	<b>20,134</b>	<b>20,209</b>	<b>20,329</b>

\*Full compliance to ISO 14397-1 (2007) Sections 1 thru 6, which requires 2% verification between calculation and testing.

\*\*Compliance to ISO 14397-1 (2007) Sections 1 thru 5.

**NOTE:** Dimensions listed are for a 914M configured with buckets, bolt-on cutting edges, optional counterweights, additional guarding, 80 kg (176 lb) operator, and Michelin 15.5 R25 (L2) XTLA tires at a pressure of 4.14 bar (60 psi) in the front tires and 2.76 bar (40 psi) in the rear tires.

Performance Data  
 ● 914M  
 ● Pallet Forks  
 ● Material Handling Arm

Wheel Loaders  
 Integrated Toolcarriers

		Pallet Forks — Standard Lift IT	Pallet Forks — High Lift IT
Fork tine length	mm	1200	1200
	ft/in	3'11"	3'11"
Load center	mm	600	600
	ft/in	1'11"	1'11"
Overall length	mm	6706	7259
	ft/in	22'0"	23'9"
Ground reach	mm	637	1189
	ft/in	2'1"	3'10"
Digging depth	mm	51	235
	in	2	9.2
Level arm reach	mm	1324	1739
	ft/in	4'4"	5'8"
Full lift reach	mm	472	691
	ft/in	1'6"	2'3"
Level arm clearance	mm	1689	1689
	ft/in	5'6"	5'6"
Full lift clearance	mm	3485	3838
	ft/in	11'5"	12'7"
Overall height	mm	4472	4825
	ft/in	14'8"	15'9"
Tipping load — straight (ISO 14397-1)*	kg	5020	4174
	lb	11,064	9200
Tipping load — full turn (ISO 14397-1)*	kg	4237	3502
	lb	9338	7717
Operating weight	kg	8598	8653
	lb	18,951	19,070
Rated load (% of full turn tip): 50% of tip (SAE J1197)**	kg	2119	1751
	lb	4669	3858
Rated load (% of full turn tip): 60% of tip — rough terrain (EN474-3)**	kg	2542	2101
	lb	5603	4630
Rated load (% of full turn tip): 80% of tip — firm and level (EN474-3)**	kg	3390	2801
	lb	7470	6174
Minimum fork spacing	mm	300	300
	in	11	11
Carriage width	mm	1550	1550
	ft/in	5'1"	5'1"
Maximum fork spacing	mm	1526	1526
	ft/in	5'0"	5'0"

\*Full compliance to ISO 14397-1 (2007) Sections 1 thru 6, which requires 2% verification between calculation and testing.

\*\*Full compliance to EN474-3 and SAE J1197.

**NOTE:** Dimensions listed are for a machine configured with IT work tools, optional counterweights, additional guarding, 80 kg (176 lb) operator, and Michelin 175 R25 L2 XTLA tires.

Handling Arm Position		Material Handling Arm — Standard Lift		
		Retracted	Mid-position	Extended
Rated load (50% of full turn tip* SAE J1197)	kg	1422	1116	920
	lb	3134	2459	2026
Operating weight	kg	8567	8567	8567
	lb	18,881	18,881	18,881

\*Full compliance to EN474-3 and SAE J1197.



Bucket Type	General Purpose					
	Pin On					
Ground Engaging Type	Bolt-on Cutting Edges					
Rated capacity 100%	m <sup>3</sup>	1.3	1.4	1.6	1.8	1.9
	yd <sup>3</sup>	<b>1.7</b>	<b>1.8</b>	<b>2.1</b>	<b>2.4</b>	<b>2.5</b>
Rated capacity 110%	m <sup>3</sup>	1.4	1.5	1.7	1.9	2.0
	yd <sup>3</sup>	<b>1.8</b>	<b>2.0</b>	<b>2.2</b>	<b>2.5</b>	<b>2.6</b>
Struck capacity	m <sup>3</sup>	1.25	1.15	1.45	1.65	1.75
	yd <sup>3</sup>	<b>1.6</b>	<b>1.5</b>	<b>1.9</b>	<b>2.2</b>	<b>2.3</b>
Width: bucket	mm	2320	2401	2401	2401	2401
	ft/in	<b>7'7"</b>	<b>7'10"</b>	<b>7'10"</b>	<b>7'10"</b>	<b>7'10"</b>
Nominal material density, 100% fill factor	kg/m <sup>3</sup>	2425	2254	1947	1710	1612
	lb/yd <sup>3</sup>	<b>4087</b>	<b>3863</b>	<b>3270</b>	<b>2827</b>	<b>2699</b>
Nominal material density, 110% fill factor	kg/m <sup>3</sup>	2252	2104	1833	1620	1531
	lb/yd <sup>3</sup>	<b>4107</b>	<b>3699</b>	<b>3320</b>	<b>2887</b>	<b>2761</b>
Clearance: full lift, 45° dump	mm	2990	2990	2937	2882	2857
	ft/in	<b>9'9"</b>	<b>9'9"</b>	<b>9'7"</b>	<b>9'5"</b>	<b>9'4"</b>
Reach: full lift, 45° dump	mm	781	781	833	881	902
	ft/in	<b>2'6"</b>	<b>2'6"</b>	<b>2'8"</b>	<b>2'10"</b>	<b>2'11"</b>
Reach: 2130 mm (7'0") clearance, 45° dump	mm	1446	1446	1473	1493	1500
	ft/in	<b>4'8"</b>	<b>4'8"</b>	<b>4'9"</b>	<b>4'10"</b>	<b>4'11"</b>
Reach: level arm, level bucket	mm	2093	2093	2169	2242	2276
	ft/in	<b>6'10"</b>	<b>6'10"</b>	<b>7'1"</b>	<b>7'4"</b>	<b>7'5"</b>
Dig depth	mm	60	60	60	60	60
	in	<b>2.4</b>	<b>2.4</b>	<b>2.4</b>	<b>2.4</b>	<b>2.4</b>
Length: overall	mm	6434	6434	6510	6583	6617
	ft/in	<b>21'1"</b>	<b>21'1"</b>	<b>21'4"</b>	<b>21'7"</b>	<b>21'8"</b>
Height: overall	mm	4677	4679	4737	4825	4859
	ft/in	<b>15'4"</b>	<b>15'4"</b>	<b>15'6"</b>	<b>15'9"</b>	<b>15'11"</b>
Turning radius, bucket at carry	mm	5309	5346	5368	5390	5400
	ft/in	<b>17'5"</b>	<b>17'6"</b>	<b>17'7"</b>	<b>17'8"</b>	<b>17'8"</b>
Tipping load — straight, ISO 14397-1*	kg	7431	7440	7353	7272	7235
	lb	<b>16,378</b>	<b>16,397</b>	<b>16,206</b>	<b>16,026</b>	<b>15,945</b>
Tipping load — straight, rigid tire**	kg	7741	7750	7660	7575	7536
	lb	<b>17,060</b>	<b>17,080</b>	<b>16,881</b>	<b>16,694</b>	<b>16,609</b>
Tipping load — full turn, ISO 14397-1*	kg	6306	6311	6232	6157	6124
	lb	<b>13,897</b>	<b>13,908</b>	<b>13,734</b>	<b>13,570</b>	<b>13,496</b>
Tipping load — full turn, rigid tire**	kg	6708	6713	6629	6550	6515
	lb	<b>14,784</b>	<b>14,796</b>	<b>14,610</b>	<b>14,437</b>	<b>14,358</b>
Breakout force	kg	10 804	10 791	9874	9113	8798
	lbf	<b>23,811</b>	<b>23,784</b>	<b>21,763</b>	<b>20,084</b>	<b>19,391</b>
Operating weight	kg	9188	9208	9247	9282	9298
	lb	<b>20,250</b>	<b>20,293</b>	<b>20,379</b>	<b>20,457</b>	<b>20,492</b>

\*Full compliance to ISO 14397-1 (2007) Sections 1 thru 6, which requires 2% verification between calculation and testing.

\*\*Compliance to ISO 14397-1 (2007) Sections 1 thru 5.

**NOTE:** Dimensions listed are for a 918M configured with buckets, bolt-on cutting edges, optional counterweights, additional guarding, 80 kg (176 lb) operator, and Michelin 17.5 R25 (L2) XTLA tires at a pressure of 4.14 bar (60 psi) in the front tires and 2.76 bar (40 psi) in the rear tires.

Bucket Type	General Purpose										
	IT Quick Coupler						ISO 23727 Quick Coupler				
Ground Engaging Type	Bolt-on Cutting Edges						Bolt-on Cutting Edges				
Rated capacity 100%	m <sup>3</sup>	1.3	1.3	1.5	1.6	1.7	1.9	1.3	1.5	1.7	1.9
	yd <sup>3</sup>	1.7	1.7	2.0	2.1	2.2	2.5	1.7	2.0	2.2	2.5
Rated capacity 110%	m <sup>3</sup>	1.4	1.4	1.6	1.7	1.8	2.0	1.4	1.6	1.8	2.0
	yd <sup>3</sup>	1.8	1.8	2.1	2.2	2.4	2.6	1.8	2.1	2.4	2.6
Struck capacity	m <sup>3</sup>	1.15	1.15	1.35	1.45	1.55	1.75	1.15	1.35	1.55	1.75
	yd <sup>3</sup>	1.5	1.5	1.8	1.9	2.0	2.3	1.5	1.8	2.0	2.3
Width: bucket	mm	2320	2401	2401	2401	2401	2401	2401	2401	2401	2401
	ft/in	7'7"	7'10"	7'10"	7'10"	7'10"	7'10"	7'10"	7'10"	7'10"	7'10"
Nominal material density, 100% fill factor	kg/m <sup>3</sup>	2291	2297	1965	1832	1713	1506	2245	1921	1671	1472
	lb/yd <sup>3</sup>	3862	3872	3248	3076	2918	2522	3784	3175	2845	2466
Nominal material density, 110% fill factor	kg/m <sup>3</sup>	2128	2133	1842	1724	1618	1430	2085	1801	1578	1399
	lb/yd <sup>3</sup>	3880	3890	3291	3124	2845	2580	3802	3217	2775	2522
Clearance: full lift, 45° dump	mm	2923	2954	2891	2865	2838	2780	2916	2854	2800	2754
	ft/in	9'7"	9'8"	9'5"	9'4"	9'3"	9'1"	9'6"	9'4"	9'2"	9'0"
Reach: full lift, 45° dump	mm	865	842	889	911	933	966	886	931	974	1013
	ft/in	2'10"	2'9"	2'11"	2'11"	3'0"	3'2"	2'10"	3'0"	3'2"	3'3"
Reach: 2130 mm (7'0") clearance, 45° dump	mm	1498	1491	1506	1514	1521	1521	1515	1528	1541	1553
	ft/in	4'10"	4'10"	4'11"	4'11"	4'11"	4'11"	4'11"	5'0"	5'0"	5'1"
Reach: level arm, level bucket	mm	2199	2159	2239	2274	2310	2378	2217	2295	2366	2428
	ft/in	7'2"	7'1"	7'4"	7'5"	7'6"	7'9"	7'3"	7'6"	7'9"	7'11"
Dig depth	mm	62	62	61	61	61	60	61	61	61	60
	in	2.4	2.4	2.4	2.4	2.4	2.4	2.4	2.4	2.4	2.4
Length: overall	mm	6541	6501	6581	6615	6652	6719	6558	6637	6708	6768
	ft/in	21'5"	21'3"	21'7"	21'8"	21'9"	22'0"	21'6"	21'9"	22'0"	22'2"
Height: overall	mm	4725	4707	4790	4797	4847	4928	4743	4811	4882	4962
	ft/in	15'6"	15'5"	15'8"	15'8"	15'10"	16'1"	15'6"	15'9"	16'0"	16'3"
Turning radius, bucket at carry	mm	5340	5365	5389	5399	5410	5434	5380	5404	5425	5445
	ft/in	17'6"	17'7"	17'8"	17'8"	17'8"	17'9"	17'7"	17'8"	17'9"	17'10"
Tipping load — straight, ISO 14397-1*	kg	7047	7066	6981	6944	6903	6790	6912	6829	6740	6648
	lb	15,531	15,572	15,385	15,304	15,214	14,964	15,233	15,051	14,855	14,651
Tipping load — straight, rigid tire**	kg	7340	7360	7271	7233	7191	7073	7200	7114	7021	6925
	lb	16,178	16,221	16,026	15,942	15,848	15,588	15,867	15,678	15,474	15,261
Tipping load — full turn, ISO 14397-1*	kg	5957	5973	5895	5862	5825	5722	5838	5763	5681	5594
	lb	13,130	13,164	12,993	12,920	12,837	12,611	12,866	12,700	12,520	12,329
Tipping load — full turn, rigid tire**	kg	6338	6354	6272	6236	6197	6087	6211	6130	6043	5951
	lb	13,968	14,004	13,822	13,744	13,657	13,416	13,688	13,511	13,319	13,116
Breakout force	kg	9541	9957	9116	8795	8480	7875	9325	8588	7933	7515
	lbf	21,028	21,945	20,090	19,384	18,690	17,356	20,553	18,928	17,484	16,563
Operating weight	kg	9391	9395	9435	9451	9469	9523	9418	9456	9491	9545
	lb	20,698	20,707	20,794	20,829	20,869	20,987	20,756	20,841	20,917	21,037

\*Full compliance to ISO 14397-1 (2007) Sections 1 thru 6, which requires 2% verification between calculation and testing.

\*\*Compliance to ISO 14397-1 (2007) Sections 1 thru 5.

**NOTE:** Dimensions listed are for a 918M configured with buckets, bolt-on cutting edges, optional counterweights, additional guarding, 80 kg (176 lb) operator, and Michelin 17.5 R25 (L2) XTLA tires at a pressure of 4.14 bar (60 psi) in the front tires and 2.76 bar (40 psi) in the rear tires.

# Wheel Loaders Integrated Toolcarriers

## Performance Data

- 918M
- Pallet Forks
- Material Handling Arm

		Pallet Forks — Standard Lift IT	
Fork tine length	mm	1200	
	ft/in	3'11"	
Load center	mm	600	
	ft/in	1'11"	
Overall length	mm	6927	
	ft/in	22'8"	
Ground reach	mm	744	
	ft/in	2'5"	
Digging depth	mm	23	
	in	0.9	
Level arm reach	mm	1421	
	ft/in	4'7"	
Full lift reach	mm	525	
	ft/in	1'8"	
Level arm clearance	mm	1698	
	ft/in	5'6"	
Full lift clearance	mm	3601	
	ft/in	11'9"	
Overall height	mm	4588	
	ft/in	15'0"	
Tipping load — straight (ISO 14397-1)*	kg	5552	
	lb	12,237	
Tipping load — full turn (ISO 14397-1)*	kg	4702	
	lb	10,362	
Operating weight	kg	9294	
	lb	20,483	
Rated load (% of full turn tip): 50% of tip (SAE J1197)**	kg	2351	
	lb	5181	
Rated load (% of full turn tip): 60% of tip — rough terrain (EN474-3)**	kg	2821	
	lb	6217	
Rated load (% of full turn tip): 80% of tip — firm and level (EN474-3)**	kg	3761	
	lb	8290	
Minimum fork spacing	mm	300	
	in	11	
Carriage width	mm	1550	
	ft/in	5'1"	
Maximum fork spacing	mm	1526	
	ft/in	5'0"	

\*Full compliance to ISO 14397-1 (2007) Sections 1 thru 6, which requires 2% verification between calculation and testing.

\*\*Full compliance to EN474-3 and SAE J1197.

**NOTE:** Dimensions listed are for a machine configured with IT work tools, optional counterweights, additional guarding, 80 kg (176 lb) operator, and Michelin 175 R25 L2 XTLA tires.

		Material Handling Arm — Standard Lift		
Handling Arm Position		Retracted	Mid-position	Extended
Rated load (50% of full turn tip* SAE J1197)	kg	1597	1260	1042
	lb	3520	2778	2297
Operating weight	kg	9262	9262	9262
	lb	20,413	20,413	20,413

\*Full compliance to EN474-3 and SAE J1197.

Bucket Type	General Purpose									
		Bolt-on Cutting Edges			Bolt-on Teeth & Segments			Bolt-on Teeth		
Ground Engaging Type										
	Rated bucket capacity	m <sup>3</sup>	1.90	2.10	2.30	1.90	2.10	2.30	1.80	2.00
Struck capacity	m <sup>3</sup>	1.70	1.90	2.10	1.70	1.90	2.10	1.60	1.80	2.00
	yd <sup>3</sup>	<b>2.22</b>	<b>2.49</b>	<b>2.75</b>	<b>2.22</b>	<b>2.49</b>	<b>2.75</b>	<b>2.09</b>	<b>2.35</b>	<b>2.62</b>
Bucket width	mm	2550	2550	2550	2550	2550	2550	2550	2550	2550
	ft/in	<b>8'4"</b>	<b>8'4"</b>	<b>8'4"</b>	<b>8'4"</b>	<b>8'4"</b>	<b>8'4"</b>	<b>8'4"</b>	<b>8'4"</b>	<b>8'4"</b>
Dump clearance at full lift and 45° discharge	mm	2912	2855	2807	2809	2751	2702	2809	2751	2702
	ft/in	<b>9'7"</b>	<b>9'4"</b>	<b>9'3"</b>	<b>9'3"</b>	<b>9'0"</b>	<b>8'10"</b>	<b>9'3"</b>	<b>9'0"</b>	<b>8'10"</b>
Reach at full lift and 45° discharge	mm	992	1033	1070	1097	1135	1172	1097	1135	1172
	ft/in	<b>3'3"</b>	<b>3'5"</b>	<b>3'6"</b>	<b>3'7"</b>	<b>3'9"</b>	<b>3'10"</b>	<b>3'7"</b>	<b>3'9"</b>	<b>3'10"</b>
Reach at 45° discharge and 2130 mm (7'0") clearance	mm	1547	1560	1573	1600	1608	1617	1600	1608	1617
	ft/in	<b>5'1"</b>	<b>5'1"</b>	<b>5'2"</b>	<b>5'3"</b>	<b>5'3"</b>	<b>5'4"</b>	<b>5'3"</b>	<b>5'3"</b>	<b>5'4"</b>
Reach with lift arms horizontal and bucket level	mm	2278	2350	2413	2424	2496	2559	2424	2496	2559
	ft/in	<b>7'6"</b>	<b>7'9"</b>	<b>7'11"</b>	<b>7'11"</b>	<b>8'2"</b>	<b>8'5"</b>	<b>7'11"</b>	<b>8'2"</b>	<b>8'5"</b>
Digging depth	mm	100	100	100	111	111	111	111	111	111
	in	<b>3.9</b>	<b>3.9</b>	<b>3.9</b>	<b>4.4</b>	<b>4.4</b>	<b>4.4</b>	<b>4.4</b>	<b>4.4</b>	<b>4.4</b>
Overall length	mm	7409	7481	7544	7555	7627	7690	7535	7607	7670
	ft/in	<b>24'4"</b>	<b>24'7"</b>	<b>24'9"</b>	<b>24'9"</b>	<b>25'0"</b>	<b>25'3"</b>	<b>24'9"</b>	<b>24'11"</b>	<b>25'2"</b>
Overall height with bucket at full raise	mm	5052	5122	5180	5052	5122	5180	5052	5122	5180
	ft/in	<b>16'7"</b>	<b>16'10"</b>	<b>17'0"</b>	<b>16'7"</b>	<b>16'10"</b>	<b>17'0"</b>	<b>16'7"</b>	<b>16'10"</b>	<b>17'0"</b>
Loader clearance radius with bucket in carry position	mm	5912	5933	5951	5958	5980	5999	5958	5980	5999
	ft/in	<b>19'5"</b>	<b>19'6"</b>	<b>19'6"</b>	<b>19'7"</b>	<b>19'7"</b>	<b>19'8"</b>	<b>19'7"</b>	<b>19'7"</b>	<b>19'8"</b>
Static tipping load straight	kg	9179	9115	9008	9031	8965	8857	9132	9067	8961
	lb	<b>20,236</b>	<b>20,095</b>	<b>19,859</b>	<b>19,910</b>	<b>19,764</b>	<b>19,526</b>	<b>20,133</b>	<b>19,989</b>	<b>19,756</b>
Static tipping load with 40° turn	kg	7894	7836	7737	7750	7690	7589	7848	7790	7690
	lb	<b>17,403</b>	<b>17,275</b>	<b>17,057</b>	<b>17,086</b>	<b>16,954</b>	<b>16,731</b>	<b>17,302</b>	<b>17,174</b>	<b>16,954</b>
Breakout force	kg	10 685	9956	9388	10 565	9835	9268	11 400	10 569	9928
	lbf	<b>23,557</b>	<b>21,949</b>	<b>20,697</b>	<b>23,292</b>	<b>21,683</b>	<b>20,433</b>	<b>25,133</b>	<b>23,301</b>	<b>21,888</b>
Operating weight	kg	12 696	12 715	12 778	12 816	12 835	12 899	12 734	12 753	12 817
	lb	<b>27,990</b>	<b>28,032</b>	<b>28,171</b>	<b>28,254</b>	<b>28,296</b>	<b>28,437</b>	<b>28,074</b>	<b>28,116</b>	<b>28,257</b>

\*Meets Tier 4 Final/Stage IV/Japan 2014 (Tier 4 Final) emission standards.

NOTE: Specifications and ratings conform to all applicable standards recommended by the Society of Automotive Engineers (SAE), including SAE Standards J732 (APR07) which governs loader ratings.

# Wheel Loaders Integrated Toolcarriers

## Performance Data ● 926M\* Standard Lift Pin On Bucket

Bucket Type	Light Material									
		Bolt-on Cutting Edges			Bolt-on Teeth & Segments			Bolt-on Teeth		
Ground Engaging Type										
Rated bucket capacity	m <sup>3</sup>	3.50	4.20	5.00	3.50	4.20	5.00	3.40	4.10	4.90
	yd <sup>3</sup>	<b>4.58</b>	<b>5.49</b>	<b>6.54</b>	<b>4.58</b>	<b>5.49</b>	<b>6.54</b>	<b>4.45</b>	<b>5.36</b>	<b>6.41</b>
Struck capacity	m <sup>3</sup>	3.30	4.00	4.80	3.30	4.00	4.80	3.20	3.90	4.70
	yd <sup>3</sup>	<b>4.32</b>	<b>5.23</b>	<b>6.28</b>	<b>4.32</b>	<b>5.23</b>	<b>6.28</b>	<b>4.19</b>	<b>5.10</b>	<b>6.15</b>
Bucket width	mm	2750	2750	2750	2750	2750	2750	2750	2750	2750
	ft/in	<b>9'0"</b>	<b>9'0"</b>	<b>9'0"</b>	<b>9'0"</b>	<b>9'0"</b>	<b>9'0"</b>	<b>9'0"</b>	<b>9'0"</b>	<b>9'0"</b>
Dump clearance at full lift and 45° discharge	mm	2629	2509	2509	2518	2398	2398	2518	2398	2398
	ft/in	<b>8'8"</b>	<b>8'3"</b>	<b>8'3"</b>	<b>8'3"</b>	<b>7'10"</b>	<b>7'10"</b>	<b>8'3"</b>	<b>7'10"</b>	<b>7'10"</b>
Reach at full lift and 45° discharge	mm	1137	1257	1257	1232	1352	1352	1232	1352	1352
	ft/in	<b>3'9"</b>	<b>4'1"</b>	<b>4'1"</b>	<b>4'1"</b>	<b>4'5"</b>	<b>4'5"</b>	<b>4'1"</b>	<b>4'5"</b>	<b>4'5"</b>
Reach at 45° discharge and 2130 mm (7'0") clearance	mm	1538	1579	1579	1560	1592	1592	1560	1592	1592
	ft/in	<b>5'1"</b>	<b>5'2"</b>	<b>5'2"</b>	<b>5'1"</b>	<b>5'3"</b>	<b>5'3"</b>	<b>5'1"</b>	<b>5'3"</b>	<b>5'3"</b>
Reach with lift arms horizontal and bucket level	mm	2603	2773	2773	2749	2919	2919	2749	2919	2919
	ft/in	<b>8'6"</b>	<b>9'1"</b>	<b>9'1"</b>	<b>9'0"</b>	<b>9'7"</b>	<b>9'7"</b>	<b>9'0"</b>	<b>9'7"</b>	<b>9'7"</b>
Digging depth	mm	100	100	100	111	111	111	111	111	111
	in	<b>3.9</b>	<b>3.9</b>	<b>3.9</b>	<b>4.4</b>	<b>4.4</b>	<b>4.4</b>	<b>4.4</b>	<b>4.4</b>	<b>4.4</b>
Overall length	mm	7734	7904	7904	7880	8050	8050	7860	8030	8030
	ft/in	<b>25'4"</b>	<b>25'11"</b>	<b>25'11"</b>	<b>25'10"</b>	<b>26'5"</b>	<b>26'5"</b>	<b>25'9"</b>	<b>26'4"</b>	<b>26'4"</b>
Overall height with bucket at full raise	mm	5284	5445	5725	5284	5445	5725	5284	5445	5725
	ft/in	<b>17'4"</b>	<b>17'10"</b>	<b>18'9"</b>	<b>17'4"</b>	<b>17'10"</b>	<b>18'9"</b>	<b>17'4"</b>	<b>17'10"</b>	<b>18'9"</b>
Loader clearance radius with bucket in carry position	mm	6099	6152	6152	6148	6202	6202	6148	6202	6202
	ft/in	<b>20'0"</b>	<b>20'2"</b>	<b>20'2"</b>	<b>20'2"</b>	<b>20'4"</b>	<b>20'4"</b>	<b>20'2"</b>	<b>20'4"</b>	<b>20'4"</b>
Static tipping load straight	kg	8566	8300	8260	8423	8154	8114	8529	8262	8222
	lb	<b>18,885</b>	<b>18,298</b>	<b>18,210</b>	<b>18,570</b>	<b>17,976</b>	<b>17,888</b>	<b>18,803</b>	<b>18,215</b>	<b>18,126</b>
Static tipping load with 40° turn	kg	7321	7076	7035	7181	6933	6892	7285	7039	6998
	lb	<b>16,140</b>	<b>15,600</b>	<b>15,510</b>	<b>15,831</b>	<b>15,285</b>	<b>15,194</b>	<b>16,061</b>	<b>15,518</b>	<b>15,428</b>
Breakout force	kg	7888	6893	6842	7777	6782	6731	8271	7181	7127
	lbf	<b>17,390</b>	<b>15,197</b>	<b>15,084</b>	<b>17,145</b>	<b>14,952</b>	<b>14,839</b>	<b>18,235</b>	<b>15,831</b>	<b>15,712</b>
Operating weight	kg	13 092	13 222	13 302	13 203	13 333	13 413	13 121	13 250	13 330
	lb	<b>28,863</b>	<b>29,149</b>	<b>29,326</b>	<b>29,108</b>	<b>29,394</b>	<b>29,571</b>	<b>28,927</b>	<b>29,211</b>	<b>29,388</b>

\*Meets Tier 4 Final/Stage IV/Japan 2014 (Tier 4 Final) emission standards.

**NOTE:** Specifications and ratings conform to all applicable standards recommended by the Society of Automotive Engineers (SAE), including SAE Standards J732 (APR07) which governs loader ratings.

	Change in Operating Weight		Change in Articulated Static Tipping Load	
	kg	lb	kg	lb
Without Ride Control System .....	- 31	- 68	- 14	- 31
Without Guard, driveshaft .....	- 43	- 95	- 16	- 36
With Guard, windshield .....	41	90	24	53
Without Rooding Fenders .....	- 41	- 90	- 31	- 69
Without Secondary Steering .....	- 53	- 117	- 54	- 119
Without Guard, crankcase .....	- 11	- 24	- 15	- 34
Without Guard, power train .....	- 67	- 148	- 65	- 144
With Guard, power train side .....	11	24	10	22
With Counterweight, Logger .....	298	656	417	919
With Cold Start 120V .....	54	119	93	206
With Product Link™ .....	8	18	8	18
<b>Tires, 1-piece rims</b>				
17.5-25, 12PR (L-2) .....	- 680	- 1499	- 832	- 1834
17.5-25, 12PR (L-3) .....	- 663	- 1462	- 812	- 1790
17.5-25, Radial (L-2) VUT .....	- 437	- 963	- 536	- 1182
17.5-25, Radial (L-3) VMT .....	- 377	- 831	- 462	- 1019
<b>Tires, 3-piece rims</b>				
17.5-25, 12PR (L-2) .....	- 629	- 1387	- 770	- 1698
17.5-25, 12PR (L-3) .....	- 612	- 1349	- 750	- 1653
17.5-25, Radial (L-2) VUT .....	- 386	- 851	- 473	- 1043
17.5-25, Radial (L-3) VMT .....	- 326	- 719	- 400	- 882
550/65 R25, Radial (L-3) .....	- 108	- 238	- 132	- 291
600/65 R25, Radial (L-3) .....	24	53	29	64
20.5-25, 12PR (L-2) .....	- 334	- 736	- 409	- 902
20.5-25, 12PR (L-3) .....	- 263	- 580	- 322	- 710
20.5 R25, Radial (L-5) XMINE D2 .....	616	1358	755	1664
20.5 R25, Radial (L-2) VUT .....	- 232	- 511	- 284	- 626
20.5 R25, Radial (L-3) VMT .....	56	123	69	152

\*Meets Tier 4 Final/Stage IV/Japan 2014 (Tier 4 Final) emission standards.

# Wheel Loaders Integrated Toolcarriers

## Performance Data ● 926M\* High Lift Pin On Bucket

Bucket Type		General Purpose								
		Bolt-on Cutting Edges			Bolt-on Teeth & Segments			Bolt-on Teeth		
Ground Engaging Type										
Rated bucket capacity	m <sup>3</sup>	1.90	2.10	2.30	1.90	2.10	2.30	1.80	2.00	2.20
	yd <sup>3</sup>	<b>2.49</b>	<b>2.75</b>	<b>3.01</b>	<b>2.49</b>	<b>2.75</b>	<b>3.01</b>	<b>2.35</b>	<b>2.62</b>	<b>2.88</b>
Struck capacity	m <sup>3</sup>	1.70	1.90	2.10	1.70	1.90	2.10	1.60	1.80	2.00
	yd <sup>3</sup>	<b>2.22</b>	<b>2.49</b>	<b>2.75</b>	<b>2.22</b>	<b>2.49</b>	<b>2.75</b>	<b>2.09</b>	<b>2.35</b>	<b>2.62</b>
Bucket width	mm	2550	2550	2550	2550	2550	2550	2550	2550	2550
	ft/in	<b>8'4"</b>	<b>8'4"</b>	<b>8'4"</b>	<b>8'4"</b>	<b>8'4"</b>	<b>8'4"</b>	<b>8'4"</b>	<b>8'4"</b>	<b>8'4"</b>
Dump clearance at full lift and 45° discharge	mm	3405	3348	3300	3302	3244	3195	3302	3244	3195
	ft/in	<b>11'2"</b>	<b>11'0"</b>	<b>10'10"</b>	<b>10'10"</b>	<b>10'8"</b>	<b>10'6"</b>	<b>10'10"</b>	<b>10'8"</b>	<b>10'6"</b>
Reach at full lift and 45° discharge	mm	1229	1269	1307	1333	1372	1409	1333	1372	1409
	ft/in	<b>4'0"</b>	<b>4'2"</b>	<b>4'3"</b>	<b>4'4"</b>	<b>4'6"</b>	<b>4'7"</b>	<b>4'4"</b>	<b>4'6"</b>	<b>4'7"</b>
Reach at 45° discharge and 2130 mm (7'0") clearance	mm	2113	2132	2150	2177	2191	2206	2177	2191	2206
	ft/in	<b>6'11"</b>	<b>7'0"</b>	<b>7'1"</b>	<b>7'2"</b>	<b>7'2"</b>	<b>7'3"</b>	<b>7'2"</b>	<b>7'2"</b>	<b>7'3"</b>
Reach with lift arms horizontal and bucket level	mm	2801	2873	2936	2947	3019	3082	2947	3019	3082
	ft/in	<b>9'2"</b>	<b>9'5"</b>	<b>9'8"</b>	<b>9'8"</b>	<b>9'11"</b>	<b>10'1"</b>	<b>9'8"</b>	<b>9'11"</b>	<b>10'1"</b>
Digging depth	mm	135	135	135	146	146	146	146	146	146
	in	<b>5.3</b>	<b>5.3</b>	<b>5.3</b>	<b>5.7</b>	<b>5.7</b>	<b>5.7</b>	<b>5.7</b>	<b>5.7</b>	<b>5.7</b>
Overall length	mm	8051	8123	8186	8197	8269	8332	8181	8253	8316
	ft/in	<b>26'5"</b>	<b>26'8"</b>	<b>26'10"</b>	<b>26'11"</b>	<b>27'2"</b>	<b>27'4"</b>	<b>26'10"</b>	<b>27'1"</b>	<b>27'3"</b>
Overall height with bucket at full raise	mm	5545	5615	5673	5545	5615	5673	5545	5615	5673
	ft/in	<b>18'2"</b>	<b>18'5"</b>	<b>18'7"</b>	<b>18'2"</b>	<b>18'5"</b>	<b>18'7"</b>	<b>18'2"</b>	<b>18'5"</b>	<b>18'7"</b>
Loader clearance radius with bucket in carry position	mm	6220	6244	6265	6273	6297	6319	6273	6297	6319
	ft/in	<b>20'5"</b>	<b>20'6"</b>	<b>20'7"</b>	<b>20'7"</b>	<b>20'8"</b>	<b>20'9"</b>	<b>20'7"</b>	<b>20'8"</b>	<b>20'9"</b>
Static tipping load straight	kg	6993	6944	6852	6851	6801	6708	6948	6898	6807
	lb	<b>15,417</b>	<b>15,309</b>	<b>15,106</b>	<b>15,104</b>	<b>14,994</b>	<b>14,789</b>	<b>15,318</b>	<b>15,207</b>	<b>15,007</b>
Static tipping load with 40° turn	kg	5970	5925	5839	5831	5785	5698	5926	5881	5794
	lb	<b>13,162</b>	<b>13,062</b>	<b>12,873</b>	<b>12,855</b>	<b>12,754</b>	<b>12,562</b>	<b>13,065</b>	<b>12,965</b>	<b>12,774</b>
Breakout force	kg	10 157	9462	8920	10 037	9341	8799	10 827	10 036	9425
	lbf	<b>22,392</b>	<b>20,860</b>	<b>19,665</b>	<b>22,128</b>	<b>20,593</b>	<b>19,399</b>	<b>23,870</b>	<b>22,126</b>	<b>20,779</b>
Operating weight	kg	12 974	12 993	13 057	13 095	13 114	13 177	13 012	13 031	13 095
	lb	<b>28,603</b>	<b>28,645</b>	<b>28,786</b>	<b>28,869</b>	<b>28,911</b>	<b>29,050</b>	<b>28,687</b>	<b>28,728</b>	<b>28,869</b>

\*Meets Tier 4 Final/Stage IV/Japan 2014 (Tier 4 Final) emission standards.

**NOTE:** Specifications and ratings conform to all applicable standards recommended by the Society of Automotive Engineers (SAE), including SAE Standards J732 (APR07) which governs loader ratings.

Bucket Type	Light Material									
		Bolt-on Cutting Edges			Bolt-on Teeth & Segments			Bolt-on Teeth		
Ground Engaging Type										
Rated bucket capacity	m <sup>3</sup>	3.50	4.20	5.00	3.50	4.20	5.00	3.40	4.10	4.90
	yd <sup>3</sup>	<b>4.58</b>	<b>5.49</b>	<b>6.54</b>	<b>4.58</b>	<b>5.49</b>	<b>6.54</b>	<b>4.45</b>	<b>5.36</b>	<b>6.41</b>
Struck capacity	m <sup>3</sup>	3.30	4.00	4.80	3.30	4.00	4.80	3.20	3.90	4.70
	yd <sup>3</sup>	<b>4.32</b>	<b>5.23</b>	<b>6.28</b>	<b>4.32</b>	<b>5.23</b>	<b>6.28</b>	<b>4.19</b>	<b>5.10</b>	<b>6.15</b>
Bucket width	mm	2750	2750	2750	2750	2750	2750	2750	2750	2750
	ft/in	<b>9'0"</b>	<b>9'0"</b>	<b>9'0"</b>	<b>9'0"</b>	<b>9'0"</b>	<b>9'0"</b>	<b>9'0"</b>	<b>9'0"</b>	<b>9'0"</b>
Dump clearance at full lift and 45° discharge	mm	3122	3002	3002	3011	2891	2891	3011	2891	2891
	ft/in	<b>10'3"</b>	<b>9'10"</b>	<b>9'10"</b>	<b>9'11"</b>	<b>9'6"</b>	<b>9'6"</b>	<b>9'11"</b>	<b>9'6"</b>	<b>9'6"</b>
Reach at full lift and 45° discharge	mm	1373	1493	1493	1468	1589	1589	1468	1589	1589
	ft/in	<b>4'6"</b>	<b>4'11"</b>	<b>4'11"</b>	<b>4'10"</b>	<b>5'3"</b>	<b>5'3"</b>	<b>4'10"</b>	<b>5'3"</b>	<b>5'3"</b>
Reach at 45° discharge and 2130 mm (7'0") clearance	mm	2135	2193	2193	2173	2225	2225	2173	2225	2225
	ft/in	<b>7'0"</b>	<b>7'2"</b>	<b>7'2"</b>	<b>7'2"</b>	<b>7'4"</b>	<b>7'4"</b>	<b>7'2"</b>	<b>7'4"</b>	<b>7'4"</b>
Reach with lift arms horizontal and bucket level	mm	3126	3296	3296	3272	3442	3442	3272	3442	3442
	ft/in	<b>10'3"</b>	<b>10'10"</b>	<b>10'10"</b>	<b>10'9"</b>	<b>11'4"</b>	<b>11'4"</b>	<b>10'9"</b>	<b>11'4"</b>	<b>11'4"</b>
Digging depth	mm	135	135	135	146	146	146	146	146	146
	in	<b>5.3</b>	<b>5.3</b>	<b>5.3</b>	<b>5.7</b>	<b>5.7</b>	<b>5.7</b>	<b>5.7</b>	<b>5.7</b>	<b>5.7</b>
Overall length	mm	8376	8546	8546	8522	8692	8692	8506	8676	8676
	ft/in	<b>27'6"</b>	<b>28'0"</b>	<b>28'0"</b>	<b>28'0"</b>	<b>28'6"</b>	<b>28'6"</b>	<b>27'11"</b>	<b>28'6"</b>	<b>28'6"</b>
Overall height with bucket at full raise	mm	5777	5938	6218	5777	5938	6218	5777	5938	6218
	ft/in	<b>18'11"</b>	<b>19'6"</b>	<b>20'5"</b>	<b>18'11"</b>	<b>19'6"</b>	<b>20'5"</b>	<b>18'11"</b>	<b>19'6"</b>	<b>20'5"</b>
Loader clearance radius with bucket in carry position	mm	6415	6474	6474	6470	6530	6530	6470	6530	6530
	ft/in	<b>21'1"</b>	<b>21'3"</b>	<b>21'3"</b>	<b>21'3"</b>	<b>21'5"</b>	<b>21'5"</b>	<b>21'3"</b>	<b>21'5"</b>	<b>21'5"</b>
Static tipping load straight	kg	6459	6241	6187	6323	6103	6049	6424	6205	6152
	lb	<b>14,240</b>	<b>13,759</b>	<b>13,640</b>	<b>13,940</b>	<b>13,455</b>	<b>13,336</b>	<b>14,162</b>	<b>13,680</b>	<b>13,563</b>
Static tipping load with 40° turn	kg	5465	5263	5209	5332	5127	5074	5431	5228	5174
	lb	<b>12,048</b>	<b>11,603</b>	<b>11,484</b>	<b>11,755</b>	<b>11,303</b>	<b>11,186</b>	<b>11,973</b>	<b>11,526</b>	<b>11,407</b>
Breakout force	kg	7484	6534	6483	7373	6422	6372	7841	6800	6746
	lbf	<b>16,499</b>	<b>14,405</b>	<b>14,293</b>	<b>16,255</b>	<b>14,158</b>	<b>14,048</b>	<b>17,287</b>	<b>14,992</b>	<b>14,872</b>
Operating weight	kg	13 370	13 500	13 580	13 481	13 611	13 691	13 399	13 529	13 609
	lb	<b>29,476</b>	<b>29,762</b>	<b>29,939</b>	<b>29,720</b>	<b>30,007</b>	<b>30,183</b>	<b>29,540</b>	<b>29,826</b>	<b>30,003</b>

\*Meets Tier 4 Final/Stage IV/Japan 2014 (Tier 4 Final) emission standards.

NOTE: Specifications and ratings conform to all applicable standards recommended by the Society of Automotive Engineers (SAE), including SAE Standards J732 (APR07) which governs loader ratings.



	Change in Operating Weight		Change in Articulated Static Tipping Load	
	kg	lb	kg	lb
Without Ride Control System .....	- 31	- 68	- 11	- 25
Without Guard, driveshaft .....	- 43	- 95	- 13	- 29
With Guard, windshield .....	41	90	19	42
Without Rooding Fenders .....	- 41	- 90	- 25	- 55
Without Secondary Steering .....	- 53	- 117	- 43	- 95
Without Guard, crankcase .....	- 11	- 24	- 12	- 27
Without Guard, power train .....	- 67	- 148	- 52	- 115
With Guard, power train side .....	11	24	8	18
With Toolbox Gp .....	34	75	23	51
With Cold Start 120V .....	54	119	75	165
With Product Link .....	8	18	6	14
<b>Tires, 1-piece rims</b>				
17.5-25, 12PR (L-2) .....	- 680	- 1499	- 668	- 1473
17.5-25, 12PR (L-3) .....	- 663	- 1462	- 652	- 1437
17.5-25, Radial (L-2) VUT .....	- 437	- 963	- 430	- 948
17.5-25, Radial (L-3) VMT .....	- 377	- 831	- 371	- 818
<b>Tires, 3-piece rims</b>				
17.5-25, 12PR (L-2) .....	- 629	- 1387	- 618	- 1362
17.5-25, 12PR (L-3) .....	- 612	- 1349	- 602	- 1327
17.5-25, Radial (L-2) VUT .....	- 386	- 851	- 380	- 838
17.5-25, Radial (L-3) VMT .....	- 326	- 719	- 321	- 708
550/65 R25, Radial (L-3) .....	- 108	- 238	- 106	- 234
600/65 R25, Radial (L-3) .....	24	53	24	53
20.5-25, 12PR (L-2) .....	- 334	- 736	- 328	- 723
20.5-25, 12PR (L-3) .....	- 263	- 580	- 258	- 569
20.5 R25, Radial (L-5) XMINE D2 .....	616	1358	605	1334
20.5 R25, Radial (L-2) VUT .....	- 232	- 511	- 228	- 503
20.5 R25, Radial (L-3) VMT .....	56	123	55	121

\*Meets Tier 4 Final/Stage IV/Japan 2014 (Tier 4 Final) emission standards.

Bucket Type	General Purpose									
		Bolt-on Cutting Edges			Bolt-on Teeth & Segments			Bolt-on Teeth		
Ground Engaging Type										
	Rated bucket capacity	m <sup>3</sup>	1.90	2.10	2.30	1.90	2.10	2.30	1.80	2.00
Struck capacity										
		m <sup>3</sup>	1.70	1.90	2.10	1.70	1.90	2.10	1.60	1.80
Bucket width										
		yd <sup>3</sup>	<b>2.22</b>	<b>2.49</b>	<b>2.75</b>	<b>2.22</b>	<b>2.49</b>	<b>2.75</b>	<b>2.09</b>	<b>2.35</b>
Dump clearance at full lift and 45° discharge										
		mm	2550	2550	2550	2550	2550	2550	2550	2550
Reach at full lift and 45° discharge										
		ft/in	<b>8'4"</b>	<b>8'4"</b>	<b>8'4"</b>	<b>8'4"</b>	<b>8'4"</b>	<b>8'4"</b>	<b>8'4"</b>	<b>8'4"</b>
Reach at 45° discharge and 2130 mm (7'0") clearance										
		mm	2885	2828	2779	2782	2723	2674	2782	2723
Digging depth										
		ft/in	<b>9'6"</b>	<b>9'3"</b>	<b>9'1"</b>	<b>9'2"</b>	<b>8'11"</b>	<b>8'9"</b>	<b>9'2"</b>	<b>8'11"</b>
Overall length										
		mm	1024	1064	1102	1129	1167	1204	1129	1167
Overall height with bucket at full raise										
		ft/in	<b>3'4"</b>	<b>3'6"</b>	<b>3'7"</b>	<b>3'8"</b>	<b>3'10"</b>	<b>3'11"</b>	<b>3'8"</b>	<b>3'10"</b>
Loader clearance radius with bucket in carry position										
		mm	1566	1578	1590	1618	1624	1632	1618	1624
Static tipping load straight										
		ft/in	<b>5'2"</b>	<b>5'2"</b>	<b>5'3"</b>	<b>5'4"</b>	<b>5'4"</b>	<b>5'4"</b>	<b>5'4"</b>	<b>5'4"</b>
Static tipping load with 40° turn										
		mm	2320	2392	2455	2466	2538	2601	2466	2538
Breakout force										
		ft/in	<b>7'7"</b>	<b>7'10"</b>	<b>8'1"</b>	<b>8'1"</b>	<b>8'4"</b>	<b>8'6"</b>	<b>8'1"</b>	<b>8'4"</b>
Operating weight										
		mm	100	100	100	111	111	111	111	111
Rated bucket capacity										
		in	<b>3.9</b>	<b>3.9</b>	<b>3.9</b>	<b>4.4</b>	<b>4.4</b>	<b>4.4</b>	<b>4.4</b>	<b>4.4</b>
Static tipping load with 40° turn										
		mm	7451	7523	7586	7597	7669	7732	7576	7648
Breakout force										
		ft/in	<b>24'5"</b>	<b>24'8"</b>	<b>24'11"</b>	<b>24'11"</b>	<b>25'2"</b>	<b>25'4"</b>	<b>24'10"</b>	<b>25'1"</b>
Rated bucket capacity										
		mm	5076	5147	5205	5076	5147	5205	5076	5147
Rated bucket capacity										
		ft/in	<b>16'8"</b>	<b>16'11"</b>	<b>17'1"</b>	<b>16'8"</b>	<b>16'11"</b>	<b>17'1"</b>	<b>16'8"</b>	<b>16'11"</b>
Rated bucket capacity										
		mm	5924	5945	5964	5971	5993	6012	5971	5993
Rated bucket capacity										
		ft/in	<b>19'5"</b>	<b>19'6"</b>	<b>19'7"</b>	<b>19'7"</b>	<b>19'8"</b>	<b>19'9"</b>	<b>19'7"</b>	<b>19'8"</b>
Rated bucket capacity										
		kg	8786	8701	8621	8639	8552	8470	8740	8654
Rated bucket capacity										
		lb	<b>19,370</b>	<b>19,182</b>	<b>19,006</b>	<b>19,046</b>	<b>18,854</b>	<b>18,673</b>	<b>19,268</b>	<b>19,079</b>
Rated bucket capacity										
		kg	7524	7445	7371	7380	7299	7224	7478	7399
Rated bucket capacity										
		lb	<b>16,588</b>	<b>16,413</b>	<b>16,250</b>	<b>16,270</b>	<b>16,092</b>	<b>15,926</b>	<b>16,486</b>	<b>16,312</b>
Rated bucket capacity										
		kg	10 223	9547	9019	10 102	9426	8898	10 874	10 108
Rated bucket capacity										
		lbf	<b>22,538</b>	<b>21,048</b>	<b>19,884</b>	<b>22,271</b>	<b>20,781</b>	<b>19,617</b>	<b>23,973</b>	<b>22,284</b>
Rated bucket capacity										
		kg	13 050	13 094	13 132	13 171	13 215	13 252	13 088	13 132
Rated bucket capacity										
		lb	<b>28,770</b>	<b>28,867</b>	<b>28,951</b>	<b>29,037</b>	<b>29,134</b>	<b>29,216</b>	<b>28,854</b>	<b>28,951</b>

\*Meets Tier 4 Final/Stage IV/Japan 2014 (Tier 4 Final) emission standards.

NOTE: Specifications and ratings conform to all applicable standards recommended by the Society of Automotive Engineers (SAE), including SAE Standards J732 (APR07) which governs loader ratings.

# Wheel Loaders Integrated Toolcarriers

## Performance Data ● 926M\* Standard Lift Fusion Bucket

Bucket Type	Light Material									
		Bolt-on Cutting Edges			Bolt-on Teeth & Segments			Bolt-on Teeth		
Ground Engaging Type										
Rated bucket capacity	m <sup>3</sup>	3.50	4.20	5.00	3.50	4.20	5.00	3.40	4.10	4.90
	yd <sup>3</sup>	<b>4.58</b>	<b>5.49</b>	<b>6.54</b>	<b>4.58</b>	<b>5.49</b>	<b>6.54</b>	<b>4.45</b>	<b>5.36</b>	<b>6.41</b>
Struck capacity	m <sup>3</sup>	3.30	4.00	4.80	3.30	4.00	4.80	3.20	3.90	4.70
	yd <sup>3</sup>	<b>4.32</b>	<b>5.23</b>	<b>6.28</b>	<b>4.32</b>	<b>5.23</b>	<b>6.28</b>	<b>4.19</b>	<b>5.10</b>	<b>6.15</b>
Bucket width	mm	2750	2750	2750	2750	2750	2750	2750	2750	2750
	ft/in	<b>9'0"</b>	<b>9'0"</b>	<b>9'0"</b>	<b>9'0"</b>	<b>9'0"</b>	<b>9'0"</b>	<b>9'0"</b>	<b>9'0"</b>	<b>9'0"</b>
Dump clearance at full lift and 45° discharge	mm	2600	2479	2479	2488	2368	2368	2488	2368	2368
	ft/in	<b>8'6"</b>	<b>8'2"</b>	<b>8'2"</b>	<b>8'2"</b>	<b>7'9"</b>	<b>7'9"</b>	<b>8'2"</b>	<b>7'9"</b>	<b>7'9"</b>
Reach at full lift and 45° discharge	mm	1166	1286	1286	1261	1382	1382	1261	1382	1382
	ft/in	<b>3'10"</b>	<b>4'3"</b>	<b>4'3"</b>	<b>4'2"</b>	<b>4'6"</b>	<b>4'6"</b>	<b>4'2"</b>	<b>4'6"</b>	<b>4'6"</b>
Reach at 45° discharge and 2130 mm (7'0") clearance	mm	1549	1588	1588	1569	1598	1598	1569	1598	1598
	ft/in	<b>5'1"</b>	<b>5'3"</b>	<b>5'3"</b>	<b>5'2"</b>	<b>5'3"</b>	<b>5'3"</b>	<b>5'2"</b>	<b>5'3"</b>	<b>5'3"</b>
Reach with lift arms horizontal and bucket level	mm	2645	2815	2815	2791	2961	2961	2791	2961	2961
	ft/in	<b>8'8"</b>	<b>9'3"</b>	<b>9'3"</b>	<b>9'2"</b>	<b>9'9"</b>	<b>9'9"</b>	<b>9'2"</b>	<b>9'9"</b>	<b>9'9"</b>
Digging depth	mm	100	100	100	111	111	111	111	111	111
	in	<b>3.9</b>	<b>3.9</b>	<b>3.9</b>	<b>4.4</b>	<b>4.4</b>	<b>4.4</b>	<b>4.4</b>	<b>4.4</b>	<b>4.4</b>
Overall length	mm	7776	7946	7946	7922	8092	8092	7902	8072	8072
	ft/in	<b>25'6"</b>	<b>26'1"</b>	<b>26'1"</b>	<b>26'0"</b>	<b>26'7"</b>	<b>26'7"</b>	<b>25'11"</b>	<b>26'6"</b>	<b>26'6"</b>
Overall height with bucket at full raise	mm	5309	5471	5752	5309	5471	5752	5309	5471	5752
	ft/in	<b>17'5"</b>	<b>17'11"</b>	<b>18'10"</b>	<b>17'5"</b>	<b>17'11"</b>	<b>18'10"</b>	<b>17'5"</b>	<b>17'11"</b>	<b>18'10"</b>
Loader clearance radius with bucket in carry position	mm	6112	6166	6166	6162	6217	6217	6162	6217	6217
	ft/in	<b>20'1"</b>	<b>20'3"</b>	<b>20'3"</b>	<b>20'3"</b>	<b>20'5"</b>	<b>20'5"</b>	<b>20'3"</b>	<b>20'5"</b>	<b>20'5"</b>
Static tipping load straight	kg	8181	7921	7882	8038	7776	7736	8144	7884	7844
	lb	<b>18,036</b>	<b>17,463</b>	<b>17,377</b>	<b>17,721</b>	<b>17,143</b>	<b>17,055</b>	<b>17,954</b>	<b>17,381</b>	<b>17,293</b>
Static tipping load with 40° turn	kg	6957	6718	6678	6818	6576	6535	6921	6682	6641
	lb	<b>15,338</b>	<b>14,811</b>	<b>14,722</b>	<b>15,031</b>	<b>14,498</b>	<b>14,407</b>	<b>15,258</b>	<b>14,731</b>	<b>14,641</b>
Breakout force	kg	7603	6660	6611	7492	6549	6500	7958	6927	6877
	lbf	<b>16,762</b>	<b>14,683</b>	<b>14,575</b>	<b>16,517</b>	<b>14,438</b>	<b>14,330</b>	<b>17,544</b>	<b>15,272</b>	<b>15,161</b>
Operating weight	kg	13 455	13 585	13 662	13 566	13 696	13 773	13 484	13 613	13 691
	lb	<b>29,663</b>	<b>29,950</b>	<b>30,120</b>	<b>29,908</b>	<b>30,194</b>	<b>30,364</b>	<b>29,727</b>	<b>30,011</b>	<b>30,183</b>

\*Meets Tier 4 Final/Stage IV/Japan 2014 (Tier 4 Final) emission standards.

**NOTE:** Specifications and ratings conform to all applicable standards recommended by the Society of Automotive Engineers (SAE), including SAE Standards J732 (APR07) which governs loader ratings.

	Change in Operating Weight		Change in Articulated Static Tipping Load	
	kg	lb	kg	lb
Without Ride Control System .....	- 31	- 68	- 14	- 30
Without Guard, driveshaft .....	- 43	- 95	- 16	- 36
With Guard, windshield .....	41	90	24	52
Without Rooding Fenders .....	- 41	- 90	- 31	- 68
Without Secondary Steering .....	- 53	- 117	- 53	- 117
Without Guard, crankcase .....	- 11	- 24	- 15	- 34
Without Guard, power train .....	- 67	- 148	- 64	- 142
With Guard, power train side .....	11	24	10	22
With Counterweight, Logger .....	298	656	417	919
With Cold Start 120V .....	54	119	92	203
With Product Link .....	8	18	8	18
<b>Tires, 1-piece rims</b>				
17.5-25, 12PR (L-2) .....	- 680	- 1499	- 822	- 1811
17.5-25, 12PR (L-3) .....	- 663	- 1462	- 802	- 1768
17.5-25, Radial (L-2) VUT .....	- 437	- 963	- 529	- 1166
17.5-25, Radial (L-3) VMT .....	- 377	- 831	- 456	- 1006
<b>Tires, 3-piece rims</b>				
17.5-25, 12PR (L-2) .....	- 629	- 1387	- 760	- 1675
17.5-25, 12PR (L-3) .....	- 612	- 1349	- 740	- 1631
17.5-25, Radial (L-2) VUT .....	- 386	- 851	- 467	- 1030
17.5-25, Radial (L-3) VMT .....	- 326	- 719	- 395	- 871
550/65 R25, Radial (L-3) .....	- 108	- 238	- 131	- 289
600/65 R25, Radial (L-3) .....	24	53	29	64
20.5-25, 12PR (L-2) .....	- 334	- 736	- 404	- 891
20.5-25, 12PR (L-3) .....	- 263	- 580	- 318	- 701
20.5 R25, Radial (L-5) XMINE D2 .....	616	1358	745	1642
20.5 R25, Radial (L-2) VUT .....	- 232	- 511	- 281	- 619
20.5 R25, Radial (L-3) VMT .....	56	123	68	150

\*Meets Tier 4 Final/Stage IV/Japan 2014 (Tier 4 Final) emission standards.

# Wheel Loaders Integrated Toolcarriers

## Performance Data ● 926M\* High Lift Fusion Bucket

Bucket Type		General Purpose								
		Bolt-on Cutting Edges			Bolt-on Teeth & Segments			Bolt-on Teeth		
Ground Engaging Type										
Rated bucket capacity	m <sup>3</sup>	1.90	2.10	2.30	1.90	2.10	2.30	1.80	2.00	2.20
	yd <sup>3</sup>	<b>2.49</b>	<b>2.75</b>	<b>3.01</b>	<b>2.49</b>	<b>2.75</b>	<b>3.01</b>	<b>2.35</b>	<b>2.62</b>	<b>2.88</b>
Struck capacity	m <sup>3</sup>	1.70	1.90	2.10	1.70	1.90	2.10	1.60	1.80	2.00
	yd <sup>3</sup>	<b>2.22</b>	<b>2.49</b>	<b>2.75</b>	<b>2.22</b>	<b>2.49</b>	<b>2.75</b>	<b>2.09</b>	<b>2.35</b>	<b>2.62</b>
Bucket width	mm	2550	2550	2550	2550	2550	2550	2550	2550	2550
	ft/in	<b>8'4"</b>	<b>8'4"</b>	<b>8'4"</b>	<b>8'4"</b>	<b>8'4"</b>	<b>8'4"</b>	<b>8'4"</b>	<b>8'4"</b>	<b>8'4"</b>
Dump clearance at full lift and 45° discharge	mm	3378	3321	3272	3275	3216	3167	3275	3216	3167
	ft/in	<b>11'1"</b>	<b>10'11"</b>	<b>10'9"</b>	<b>10'9"</b>	<b>10'7"</b>	<b>10'5"</b>	<b>10'9"</b>	<b>10'7"</b>	<b>10'5"</b>
Reach at full lift and 45° discharge	mm	1261	1301	1339	1365	1404	1440	1365	1404	1440
	ft/in	<b>4'2"</b>	<b>4'3"</b>	<b>4'5"</b>	<b>4'6"</b>	<b>4'7"</b>	<b>4'9"</b>	<b>4'6"</b>	<b>4'7"</b>	<b>4'9"</b>
Reach at 45° discharge and 2130 mm (7'0") clearance	mm	2135	2153	2170	2197	2210	2224	2197	2210	2224
	ft/in	<b>7'0"</b>	<b>7'1"</b>	<b>7'1"</b>	<b>7'2"</b>	<b>7'3"</b>	<b>7'4"</b>	<b>7'2"</b>	<b>7'3"</b>	<b>7'4"</b>
Reach with lift arms horizontal and bucket level	mm	2843	2915	2978	2989	3061	3124	2989	3061	3124
	ft/in	<b>9'4"</b>	<b>9'7"</b>	<b>9'9"</b>	<b>9'10"</b>	<b>10'1"</b>	<b>10'3"</b>	<b>9'10"</b>	<b>10'1"</b>	<b>10'3"</b>
Digging depth	mm	135	135	135	146	146	146	146	146	146
	in	<b>5.3</b>	<b>5.3</b>	<b>5.3</b>	<b>5.7</b>	<b>5.7</b>	<b>5.7</b>	<b>5.7</b>	<b>5.7</b>	<b>5.7</b>
Overall length	mm	8093	8165	8228	8239	8311	8374	8223	8295	8358
	ft/in	<b>26'7"</b>	<b>26'9"</b>	<b>27'0"</b>	<b>27'0"</b>	<b>27'3"</b>	<b>27'6"</b>	<b>27'0"</b>	<b>27'3"</b>	<b>27'5"</b>
Overall height with bucket at full raise	mm	5569	5640	5698	5569	5640	5698	5569	5640	5698
	ft/in	<b>18'3"</b>	<b>18'6"</b>	<b>18'8"</b>	<b>18'3"</b>	<b>18'6"</b>	<b>18'8"</b>	<b>18'3"</b>	<b>18'6"</b>	<b>18'8"</b>
Loader clearance radius with bucket in carry position	mm	6234	6258	6279	6288	6312	6334	6288	6312	6334
	ft/in	<b>20'5"</b>	<b>20'6"</b>	<b>20'7"</b>	<b>20'8"</b>	<b>20'9"</b>	<b>20'9"</b>	<b>20'8"</b>	<b>20'9"</b>	<b>20'9"</b>
Static tipping load straight	kg	6632	6562	6496	6491	6419	6352	6588	6516	6451
	lb	<b>14,621</b>	<b>14,467</b>	<b>14,321</b>	<b>14,310</b>	<b>14,151</b>	<b>14,004</b>	<b>14,524</b>	<b>14,365</b>	<b>14,222</b>
Static tipping load with 40° turn	kg	5626	5560	5499	5488	5421	5358	5583	5516	5455
	lb	<b>12,403</b>	<b>12,258</b>	<b>12,123</b>	<b>12,099</b>	<b>11,951</b>	<b>11,812</b>	<b>12,308</b>	<b>12,161</b>	<b>12,026</b>
Breakout force	kg	9714	9069	8565	9593	8949	8445	10 324	9594	9028
	lbf	<b>21,416</b>	<b>19,994</b>	<b>18,883</b>	<b>21,149</b>	<b>19,729</b>	<b>18,618</b>	<b>22,761</b>	<b>21,151</b>	<b>19,903</b>
Operating weight	kg	13 328	13 373	13 410	13 449	13 493	13 531	13 367	13 411	13 448
	lb	<b>29,383</b>	<b>29,482</b>	<b>29,564</b>	<b>29,650</b>	<b>29,747</b>	<b>29,831</b>	<b>29,469</b>	<b>29,566</b>	<b>29,648</b>

\*Meets Tier 4 Final/Stage IV/Japan 2014 (Tier 4 Final) emission standards.

**NOTE:** Specifications and ratings conform to all applicable standards recommended by the Society of Automotive Engineers (SAE), including SAE Standards J732 (APR07) which governs loader ratings.

Bucket Type		Light Material								
		Bolt-on Cutting Edges			Bolt-on Teeth & Segments			Bolt-on Teeth		
<b>Ground Engaging Type</b>										
Rated bucket capacity	m <sup>3</sup>	3.50	4.20	5.00	3.50	4.20	5.00	3.40	4.10	4.90
	yd <sup>3</sup>	<b>4.58</b>	<b>5.49</b>	<b>6.54</b>	<b>4.58</b>	<b>5.49</b>	<b>6.54</b>	<b>4.45</b>	<b>5.36</b>	<b>6.41</b>
Struck capacity	m <sup>3</sup>	3.30	4.00	4.80	3.30	4.00	4.80	3.20	3.90	4.70
	yd <sup>3</sup>	<b>4.32</b>	<b>5.23</b>	<b>6.28</b>	<b>4.32</b>	<b>5.23</b>	<b>6.28</b>	<b>4.19</b>	<b>5.10</b>	<b>6.15</b>
Bucket width	mm	2750	2750	2750	2750	2750	2750	2750	2750	2750
	ft/in	<b>9'0"</b>	<b>9'0"</b>	<b>9'0"</b>	<b>9'0"</b>	<b>9'0"</b>	<b>9'0"</b>	<b>9'0"</b>	<b>9'0"</b>	<b>9'0"</b>
Dump clearance at full lift and 45° discharge	mm	3093	2972	2972	2981	2861	2861	2981	2861	2861
	ft/in	<b>10'2"</b>	<b>9'9"</b>	<b>9'9"</b>	<b>9'9"</b>	<b>9'5"</b>	<b>9'5"</b>	<b>9'9"</b>	<b>9'5"</b>	<b>9'5"</b>
Reach at full lift and 45° discharge	mm	1403	1523	1523	1498	1618	1618	1498	1618	1618
	ft/in	<b>4'7"</b>	<b>5'0"</b>	<b>5'0"</b>	<b>4'11"</b>	<b>5'4"</b>	<b>5'4"</b>	<b>4'11"</b>	<b>5'4"</b>	<b>5'4"</b>
Reach at 45° discharge and 2130 mm (7'0") clearance	mm	2150	2207	2207	2186	2236	2236	2186	2236	2236
	ft/in	<b>7'1"</b>	<b>7'3"</b>	<b>7'3"</b>	<b>7'2"</b>	<b>7'4"</b>	<b>7'4"</b>	<b>7'2"</b>	<b>7'4"</b>	<b>7'4"</b>
Reach with lift arms horizontal and bucket level	mm	3168	3338	3338	3314	3484	3484	3314	3484	3484
	ft/in	<b>10'5"</b>	<b>10'11"</b>	<b>10'11"</b>	<b>10'10"</b>	<b>11'5"</b>	<b>11'5"</b>	<b>10'10"</b>	<b>11'5"</b>	<b>11'5"</b>
Digging depth	mm	135	135	135	146	146	146	146	146	146
	in	<b>5.3</b>	<b>5.3</b>	<b>5.3</b>	<b>5.7</b>	<b>5.7</b>	<b>5.7</b>	<b>5.7</b>	<b>5.7</b>	<b>5.7</b>
Overall length	mm	8418	8588	8588	8564	8734	8734	8548	8718	8718
	ft/in	<b>27'7"</b>	<b>28'2"</b>	<b>28'2"</b>	<b>28'1"</b>	<b>28'8"</b>	<b>28'8"</b>	<b>28'1"</b>	<b>28'7"</b>	<b>28'7"</b>
Overall height with bucket at full raise	mm	5802	5964	6245	5802	5964	6245	5802	5964	6245
	ft/in	<b>19'0"</b>	<b>19'7"</b>	<b>20'6"</b>	<b>19'0"</b>	<b>19'7"</b>	<b>20'6"</b>	<b>19'0"</b>	<b>19'7"</b>	<b>20'6"</b>
Loader clearance radius with bucket in carry position	mm	6430	6489	6489	6485	6545	6545	6485	6545	6545
	ft/in	<b>21'1"</b>	<b>21'3"</b>	<b>21'3"</b>	<b>21'3"</b>	<b>21'6"</b>	<b>21'6"</b>	<b>21'3"</b>	<b>21'6"</b>	<b>21'6"</b>
Static tipping load straight	kg	6102	5890	5837	5967	5751	5699	6067	5854	5801
	lb	<b>13,453</b>	<b>12,985</b>	<b>12,868</b>	<b>13,155</b>	<b>12,679</b>	<b>12,564</b>	<b>13,375</b>	<b>12,906</b>	<b>12,789</b>
Static tipping load with 40° turn	kg	5125	4927	4875	4992	4792	4739	5091	4892	4840
	lb	<b>11,299</b>	<b>10,862</b>	<b>10,748</b>	<b>11,005</b>	<b>10,565</b>	<b>10,448</b>	<b>11,224</b>	<b>10,785</b>	<b>10,670</b>
Breakout force	kg	7210	6309	6261	7099	6198	6149	7540	6556	6506
	lbf	<b>15,895</b>	<b>13,909</b>	<b>13,803</b>	<b>15,651</b>	<b>13,664</b>	<b>13,556</b>	<b>16,623</b>	<b>14,454</b>	<b>14,343</b>
Operating weight	kg	13 733	13 683	13 940	13 844	13 974	14 051	13 762	13 982	13 969
	lb	<b>30,276</b>	<b>30,166</b>	<b>30,732</b>	<b>30,521</b>	<b>30,807</b>	<b>30,977</b>	<b>30,340</b>	<b>30,825</b>	<b>30,796</b>

\*Meets Tier 4 Final/Stage IV/Japan 2014 (Tier 4 Final) emission standards.

**NOTE:** Specifications and ratings conform to all applicable standards recommended by the Society of Automotive Engineers (SAE), including SAE Standards J732 (APR07) which governs loader ratings.

	Change in Operating Weight		Change in Articulated Static Tipping Load	
	kg	lb	kg	lb
Without Ride Control System .....	- 31	- 68	- 11	- 24
Without Guard, driveshaft .....	- 43	- 95	- 13	- 29
With Guard, windshield .....	41	90	19	42
Without Roading Fenders .....	- 41	- 90	- 25	- 55
Without Secondary Steering .....	- 53	- 117	- 43	- 94
Without Guard, crankcase .....	- 11	- 24	- 12	- 27
Without Guard, power train .....	- 67	- 148	- 52	- 114
With Guard, power train side .....	11	24	8	17
With Cold Start 120V .....	54	119	74	163
With Product Link .....	8	18	6	14
<b>Tires, 1-piece rims</b>				
17.5-25, 12PR (L-2) .....	- 680	- 1499	- 661	- 1457
17.5-25, 12PR (L-3) .....	- 663	- 1462	- 645	- 1422
17.5-25, Radial (L-2) VUT .....	- 437	- 963	- 425	- 937
17.5-25, Radial (L-3) VMT .....	- 377	- 831	- 367	- 809
<b>Tires, 3-piece rims</b>				
17.5-25, 12PR (L-2) .....	- 629	- 1387	- 611	- 1348
17.5-25, 12PR (L-3) .....	- 612	- 1349	- 595	- 1313
17.5-25, Radial (L-2) VUT .....	- 386	- 851	- 376	- 828
17.5-25, Radial (L-3) VMT .....	- 326	- 719	- 317	- 700
550/65 R25, Radial (L-3) .....	- 108	- 238	- 105	- 231
600/65 R25, Radial (L-3) .....	24	53	23	51
20.5-25, 12PR (L-2) .....	- 334	- 736	- 325	- 716
20.5-25, 12PR (L-3) .....	- 263	- 580	- 256	- 564
20.5 R25, Radial (L-5) XMINE D2 .....	616	1358	599	1321
20.5 R25, Radial (L-2) VUT .....	- 232	- 511	- 226	- 498
20.5 R25, Radial (L-3) VMT .....	56	123	54	119

\*Meets Tier 4 Final/Stage IV/Japan 2014 (Tier 4 Final) emission standards.

Bucket Type		General Purpose								
		Bolt-on Cutting Edges			Bolt-on Teeth & Segments			Bolt-on Teeth		
<b>Ground Engaging Type</b>										
Rated bucket capacity	m <sup>3</sup>	2.10	2.30	2.70	2.10	2.30	2.70	2.00	2.20	2.60
	yd <sup>3</sup>	<b>2.75</b>	<b>3.01</b>	<b>3.53</b>	<b>2.75</b>	<b>3.01</b>	<b>3.53</b>	<b>2.62</b>	<b>2.88</b>	<b>3.40</b>
Struck capacity	m <sup>3</sup>	2.00	2.20	2.60	2.00	2.20	2.60	1.90	2.10	2.50
	yd <sup>3</sup>	<b>2.62</b>	<b>2.88</b>	<b>3.40</b>	<b>2.62</b>	<b>2.88</b>	<b>3.40</b>	<b>2.49</b>	<b>2.75</b>	<b>3.27</b>
Bucket width	mm	2550	2550	2750	2550	2550	2750	2550	2550	2750
	ft/in	<b>8'4"</b>	<b>8'4"</b>	<b>9'0"</b>	<b>8'4"</b>	<b>8'4"</b>	<b>9'0"</b>	<b>8'4"</b>	<b>8'4"</b>	<b>9'0"</b>
Dump clearance at full lift and 45° discharge	mm	2747	2698	2650	2643	2593	2544	2643	2593	2544
	ft/in	<b>9'0"</b>	<b>8'10"</b>	<b>8'8"</b>	<b>8'8"</b>	<b>8'6"</b>	<b>8'4"</b>	<b>8'8"</b>	<b>8'6"</b>	<b>8'4"</b>
Reach at full lift and 45° discharge	mm	1168	1205	1243	1271	1307	1344	1271	1307	1344
	ft/in	<b>3'10"</b>	<b>3'11"</b>	<b>4'1"</b>	<b>4'2"</b>	<b>4'3"</b>	<b>4'5"</b>	<b>4'2"</b>	<b>4'3"</b>	<b>4'5"</b>
Reach at 45° discharge and 2130 mm (7'0") clearance	mm	1639	1648	1657	1681	1685	1690	1681	1685	1690
	ft/in	<b>5'5"</b>	<b>5'5"</b>	<b>5'5"</b>	<b>5'6"</b>	<b>5'6"</b>	<b>5'7"</b>	<b>5'6"</b>	<b>5'6"</b>	<b>5'7"</b>
Reach with lift arms horizontal and bucket level	mm	2523	2586	2648	2669	2732	2794	2669	2732	2794
	ft/in	<b>8'3"</b>	<b>8'6"</b>	<b>8'8"</b>	<b>8'9"</b>	<b>9'0"</b>	<b>9'2"</b>	<b>8'9"</b>	<b>9'0"</b>	<b>9'2"</b>
Digging depth	mm	93	93	93	104	104	104	104	104	104
	in	<b>3.7</b>	<b>3.7</b>	<b>3.7</b>	<b>4.1</b>	<b>4.1</b>	<b>4.1</b>	<b>4.1</b>	<b>4.1</b>	<b>4.1</b>
Overall length	mm	7648	7711	7773	7794	7857	7919	7774	7837	7899
	ft/in	<b>25'1"</b>	<b>25'4"</b>	<b>25'6"</b>	<b>25'7"</b>	<b>25'9"</b>	<b>26'0"</b>	<b>25'6"</b>	<b>25'9"</b>	<b>25'11"</b>
Overall height with bucket at full raise	mm	5236	5294	5353	5236	5294	5353	5236	5294	5353
	ft/in	<b>17'2"</b>	<b>17'4"</b>	<b>17'7"</b>	<b>17'2"</b>	<b>17'4"</b>	<b>17'7"</b>	<b>17'2"</b>	<b>17'4"</b>	<b>17'7"</b>
Loader clearance radius with bucket in carry position	mm	5964	5984	6095	6015	6036	6146	6015	6036	6146
	ft/in	<b>19'7"</b>	<b>19'8"</b>	<b>20'0"</b>	<b>19'9"</b>	<b>19'10"</b>	<b>20'2"</b>	<b>19'9"</b>	<b>19'10"</b>	<b>20'2"</b>
Static tipping load straight	kg	8268	8190	8002	8120	8041	7864	8221	8143	7966
	lb	<b>18,228</b>	<b>18,056</b>	<b>17,641</b>	<b>17,902</b>	<b>17,727</b>	<b>17,337</b>	<b>18,124</b>	<b>17,952</b>	<b>17,562</b>
Static tipping load with 40° turn	kg	7070	6999	6819	6926	6953	6684	7025	6953	6784
	lb	<b>15,587</b>	<b>15,430</b>	<b>15,033</b>	<b>15,269</b>	<b>15,329</b>	<b>14,736</b>	<b>15,487</b>	<b>15,329</b>	<b>14,956</b>
Breakout force	kg	8451	8020	7566	8330	7899	7455	8881	8404	7916
	lbf	<b>18,631</b>	<b>17,681</b>	<b>16,680</b>	<b>18,365</b>	<b>17,414</b>	<b>16,436</b>	<b>19,579</b>	<b>18,528</b>	<b>17,452</b>
Operating weight	kg	13 060	13 098	13 253	13 181	13 219	13 364	13 098	13 137	13 281
	lb	<b>28,792</b>	<b>28,876</b>	<b>29,218</b>	<b>29,059</b>	<b>29,143</b>	<b>29,463</b>	<b>28,876</b>	<b>28,962</b>	<b>29,280</b>

\*Meets Tier 4 Final/Stage IV/Japan 2014 (Tier 4 Final) emission standards.

NOTE: Specifications and ratings conform to all applicable standards recommended by the Society of Automotive Engineers (SAE), including SAE Standards J732 (APR07) which governs loader ratings.



	Change in Operating Weight		Change in Articulated Static Tipping Load	
	kg	lb	kg	lb
Without Ride Control System .....	- 31	- 68	- 13	- 29
Without Guard, driveshaft .....	- 43	- 95	- 16	- 34
With Guard, windshield .....	41	90	23	50
Without Rooding Fenders .....	- 41	- 90	- 30	- 65
Without Secondary Steering .....	- 53	- 117	- 51	- 112
Without Guard, crankcase .....	- 11	- 24	- 15	- 32
Without Guard, power train .....	- 67	- 148	- 62	- 136
With Guard, power train side .....	11	24	9	21
With Counterweight, Logger .....	298	656	417	919
With Cold Start 120V .....	54	119	88	195
With Product Link .....	8	18	8	17
<b>Tires, 1-piece rims</b>				
17.5-25, 12PR (L-2) .....	- 680	- 1499	- 788	- 1736
17.5-25, 12PR (L-3) .....	- 663	- 1462	- 769	- 1695
17.5-25, Radial (L-2) VUT .....	- 437	- 963	- 507	- 1117
17.5-25, Radial (L-3) VMT .....	- 377	- 831	- 437	- 964
<b>Tires, 3-piece rims</b>				
17.5-25, 12PR (L-2) .....	- 629	- 1387	- 729	- 1606
17.5-25, 12PR (L-3) .....	- 612	- 1349	- 710	- 1565
17.5-25, Radial (L-2) VUT .....	- 386	- 851	- 448	- 987
17.5-25, Radial (L-3) VMT .....	- 326	- 719	- 378	- 834
550/65 R25, Radial (L-3) .....	- 108	- 238	- 125	- 276
600/65 R25, Radial (L-3) .....	24	53	28	62
20.5-25, 12PR (L-2) .....	- 334	- 736	- 387	- 853
20.5-25, 12PR (L-3) .....	- 263	- 580	- 305	- 672
20.5 R25, Radial (L-5) XMINE D2 .....	616	1358	714	1574
20.5 R25, Radial (L-2) VUT .....	- 232	- 511	- 269	- 593
20.5 R25, Radial (L-3) VMT .....	56	123	65	143

\*Meets Tier 4 Final/Stage IV/Japan 2014 (Tier 4 Final) emission standards.

Bucket Type		General Purpose								
		Bolt-on Cutting Edges			Bolt-on Teeth & Segments			Bolt-on Teeth		
<b>Ground Engaging Type</b>										
Rated bucket capacity	m <sup>3</sup>	2.10	2.30	2.70	2.10	2.30	2.70	2.00	2.20	2.60
	yd <sup>3</sup>	<b>2.75</b>	<b>3.01</b>	<b>3.53</b>	<b>2.75</b>	<b>3.01</b>	<b>3.53</b>	<b>2.62</b>	<b>2.88</b>	<b>3.40</b>
Struck capacity	m <sup>3</sup>	2.00	2.20	2.60	2.00	2.20	2.60	1.90	2.10	2.50
	yd <sup>3</sup>	<b>2.62</b>	<b>2.88</b>	<b>3.40</b>	<b>2.62</b>	<b>2.88</b>	<b>3.40</b>	<b>2.49</b>	<b>2.75</b>	<b>3.27</b>
Bucket width	mm	2550	2550	2750	2550	2550	2750	2550	2550	2750
	ft/in	<b>8'4"</b>	<b>8'4"</b>	<b>9'0"</b>	<b>8'4"</b>	<b>8'4"</b>	<b>9'0"</b>	<b>8'4"</b>	<b>8'4"</b>	<b>9'0"</b>
Dump clearance at full lift and 45° discharge	mm	3240	3191	3143	3136	3085	3037	3136	3085	3037
	ft/in	<b>10'8"</b>	<b>10'6"</b>	<b>10'4"</b>	<b>10'3"</b>	<b>10'1"</b>	<b>10'0"</b>	<b>10'3"</b>	<b>10'1"</b>	<b>10'0"</b>
Reach at full lift and 45° discharge	mm	1405	1442	1479	1508	1543	1580	1508	1543	1580
	ft/in	<b>4'7"</b>	<b>4'9"</b>	<b>4'10"</b>	<b>4'11"</b>	<b>5'1"</b>	<b>5'2"</b>	<b>4'11"</b>	<b>5'1"</b>	<b>5'2"</b>
Reach at 45° discharge and 2130 mm (7'0") clearance	mm	2222	2236	2252	2276	2287	2299	2276	2287	2299
	ft/in	<b>7'3"</b>	<b>7'4"</b>	<b>7'5"</b>	<b>7'6"</b>	<b>7'6"</b>	<b>7'7"</b>	<b>7'6"</b>	<b>7'6"</b>	<b>7'7"</b>
Reach with lift arms horizontal and bucket level	mm	3046	3109	3171	3192	3255	3317	3192	3255	3317
	ft/in	<b>10'0"</b>	<b>10'2"</b>	<b>10'5"</b>	<b>10'6"</b>	<b>10'8"</b>	<b>10'11"</b>	<b>10'6"</b>	<b>10'8"</b>	<b>10'11"</b>
Digging depth	mm	128	128	128	139	139	139	139	139	139
	in	<b>5.0</b>	<b>5.0</b>	<b>5.0</b>	<b>5.5</b>	<b>5.5</b>	<b>5.5</b>	<b>5.5</b>	<b>5.5</b>	<b>5.5</b>
Overall length	mm	8291	8354	8416	8437	8500	8562	8422	8485	8547
	ft/in	<b>27'2"</b>	<b>27'5"</b>	<b>27'7"</b>	<b>27'8"</b>	<b>27'11"</b>	<b>28'1"</b>	<b>27'8"</b>	<b>27'10"</b>	<b>28'0"</b>
Overall height with bucket at full raise	mm	5729	5787	5846	5729	5787	5846	5729	5787	5846
	ft/in	<b>18'10"</b>	<b>19'0"</b>	<b>19'2"</b>	<b>18'10"</b>	<b>19'0"</b>	<b>19'2"</b>	<b>18'10"</b>	<b>19'0"</b>	<b>19'2"</b>
Loader clearance radius with bucket in carry position	mm	6288	6311	6419	6346	6369	6477	6346	6369	6477
	ft/in	<b>20'8"</b>	<b>20'8"</b>	<b>21'1"</b>	<b>20'10"</b>	<b>20'11"</b>	<b>21'3"</b>	<b>20'10"</b>	<b>20'11"</b>	<b>21'3"</b>
Static tipping load straight	kg	6291	6226	6052	6149	6083	5919	6246	6181	6017
	lb	<b>13,869</b>	<b>13,726</b>	<b>13,342</b>	<b>13,556</b>	<b>13,411</b>	<b>13,049</b>	<b>13,770</b>	<b>13,627</b>	<b>13,265</b>
Static tipping load with 40° turn	kg	5328	5268	5100	5189	5128	4970	5284	5223	5067
	lb	<b>11,746</b>	<b>11,614</b>	<b>11,244</b>	<b>11,440</b>	<b>11,305</b>	<b>10,957</b>	<b>11,649</b>	<b>11,515</b>	<b>11,171</b>
Breakout force	kg	8015	7604	7169	7895	7484	7057	8417	7962	7494
	lbf	<b>17,670</b>	<b>16,764</b>	<b>15,805</b>	<b>17,406</b>	<b>16,499</b>	<b>15,558</b>	<b>18,556</b>	<b>17,553</b>	<b>16,522</b>
Operating weight	kg	13 339	13 377	13 531	13 459	13 497	13 642	13 377	13 415	13 560
	lb	<b>29,407</b>	<b>29,491</b>	<b>29,831</b>	<b>29,672</b>	<b>29,756</b>	<b>30,075</b>	<b>29,491</b>	<b>29,575</b>	<b>29,895</b>

\*Meets Tier 4 Final/Stage IV/Japan 2014 (Tier 4 Final) emission standards.

**NOTE:** Specifications and ratings conform to all applicable standards recommended by the Society of Automotive Engineers (SAE), including SAE Standards J732 (APR07) which governs loader ratings.

	Change in Operating Weight		Change in Articulated Static Tipping Load	
	kg	lb	kg	lb
Without Ride Control System .....	- 31	- 68	- 10	- 23
Without Guard, driveshaft .....	- 43	- 95	- 12	- 27
With Guard, windshield .....	41	90	18	39
Without Rooding Fenders .....	- 41	- 90	- 23	- 51
Without Secondary Steering .....	- 53	- 117	- 40	- 88
Without Guard, Crankcase .....	- 11	- 24	- 11	- 25
Without Guard, power train .....	- 67	- 148	- 48	- 106
With Guard, power train side .....	11	24	7	16
With Cold Start 120V .....	54	119	69	152
With Product Link .....	8	18	6	13
<b>Tires, 1-piece rims</b>				
17.5-25, 12PR (L-2) .....	- 680	- 1499	- 613	- 1352
17.5-25, 12PR (L-3) .....	- 663	- 1462	- 599	- 1320
17.5-25, Radial (L-2) VUT .....	- 437	- 963	- 395	- 870
17.5-25, Radial (L-3) VMT .....	- 377	- 831	- 341	- 751
<b>Tires, 3-piece rims</b>				
17.5-25, 12PR (L-2) .....	- 629	- 1387	- 567	- 1251
17.5-25, 12PR (L-3) .....	- 612	- 1349	- 553	- 1219
17.5-25, Radial (L-2) VUT .....	- 386	- 851	- 349	- 769
17.5-25, Radial (L-3) VMT .....	- 326	- 719	- 295	- 650
550/65 R25, Radial (L-3) .....	- 108	- 238	- 97	- 214
600/65 R25, Radial (L-3) .....	24	53	22	49
20.5-25, 12PR (L-2) .....	- 334	- 736	- 301	- 664
20.5-25, 12PR (L-3) .....	- 263	- 580	- 237	- 522
20.5 R25, Radial (L-5) XMINE D2 .....	616	1358	556	1226
20.5 R25, Radial (L-2) VUT .....	- 232	- 511	- 209	- 461
20.5 R25, Radial (L-3) VMT .....	56	123	51	112

\*Meets Tier 4 Final/Stage IV/Japan 2014 (Tier 4 Final) emission standards.

- Performance Data
- 926M\* Standard Lift
  - Pallet Forks ● Construction Forks

## Wheel Loaders Integrated Toolcarriers

		Pallet Forks – Fusion		
Fork tine length	mm	1220	1370	1524
	ft/in	4'0"	4'6"	5'0"
Ground to top of tine clearance	mm	3693	3693	3693
	ft/in	12'1"	12'1"	12'1"
Reach with lift arms horizontal and forks level	mm	1569	1569	1569
	ft/in	5'2"	5'2"	5'2"
Overall length	mm	7875	8025	8179
	ft/in	25'10"	26'4"	26'10"
Static tipping load with level arms and forks, straight	kg	6756	6564	6375
	lb	14,894	14,471	14,054
Static tipping load with level arms and forks, full 40° turn	kg	5807	5638	5473
	lb	12,802	12,430	12,066
Operating weight	kg	12 759	12 780	12 802
	lb	28,129	28,175	28,224

		Pallet Forks – ISO		
Fork tine length	mm	1220	1370	1524
	ft/in	4'0"	4'6"	5'0"
Ground to top of tine clearance	mm	3693	3693	3693
	ft/in	12'1"	12'1"	12'1"
Reach with lift arms horizontal and forks level	mm	1595	1595	1595
	ft/in	5'3"	5'3"	5'3"
Overall length	mm	7906	8056	8210
	ft/in	25'11"	26'5"	26'11"
Static tipping load with level arms and forks, straight	kg	6681	6493	6309
	lb	14,729	14,315	13,909
Static tipping load with level arms and forks, full 40° turn	kg	5748	5584	5422
	lb	12,672	12,311	11,953
Operating weight	kg	12 629	12 650	12 672
	lb	27,842	27,888	27,937

		Construction Forks – Fusion	
Fork tine length	mm	1524	1829
	ft/in	5'0"	6'0"
Ground to top of tine clearance	mm	3630	3630
	ft/in	11'11"	11'11"
Reach with lift arms horizontal and forks level	mm	1627	1627
	ft/in	5'4"	5'4"
Overall length	mm	8298	8603
	ft/in	27'3"	28'3"
Static tipping load with level arms and forks, straight	kg	6049	5720
	lb	13,336	12,610
Static tipping load with level arms and forks, full 40° turn	kg	5168	4881
	lb	11,393	10,761
Operating weight	kg	13 094	13 138
	lb	28,867	28,964

\*Meets Tier 4 Final/Stage IV/Japan 2014 (Tier 4 Final) emission standards.

NOTE: Dimensions listed are for a machine configured with attachment, counterweights, additional guarding, 80 kg (176 lb) operator, and Michelin 20.5 R25 (L-3) XHA2 tires.

# Wheel Loaders Integrated Toolcarriers

- ## Performance Data
- 926M\* Standard Lift
  - Material Handling Arm

Handling Arm Position		Material Handling Arm – Fusion		
		Retracted	Mid-position	Extended
Operating load	kg	1928	1636	1420
	lb	<b>4251</b>	<b>3606</b>	<b>3129</b>
Static tipping load, straight	kg	4390	3724	3233
	lb	<b>9678</b>	<b>8210</b>	<b>7128</b>
Static tipping load, full 40° turn	kg	3856	3271	2839
	lb	<b>8501</b>	<b>7211</b>	<b>6259</b>
Operating weight	kg	12 626	12 626	12 626
	lb	<b>27,836</b>	<b>27,836</b>	<b>27,836</b>

\*Meets Tier 4 Final/Stage IV/Japan 2014 (Tier 4 Final) emission standards.

**NOTE:** Dimensions listed are for a machine configured with attachment, counterweights, additional guarding, 80 kg (**176 lb**) operator, and Michelin 20.5 R25 (L-3) XHA2 tires.

- Performance Data  
 ● 926M\* High Lift  
 ● Pallet Forks ● Construction Forks

Wheel Loaders  
 Integrated Toolcarriers

		Pallet Forks – Fusion		
Fork tine length	mm	1220	1372	1524
	ft/in	4'0"	4'6"	5'0"
Ground to top of tine clearance	mm	4186	4186	4186
	ft/in	13'9"	13'9"	13'9"
Reach with lift arms horizontal and forks level	mm	2092	2092	2092
	ft/in	6'10"	6'10"	6'10"
Overall length	mm	8528	8678	8832
	ft/in	28'0"	28'6"	29'0"
Static tipping load with level arms and forks, straight	kg	2317	2256	2196
	lb	5108	4974	4841
Static tipping load with level arms and forks, full 40° turn	kg	2780	2707	2635
	lb	6129	5968	5809
Operating weight	kg	3706	3610	3514
	lb	8170	7959	7747

		Pallet Forks – ISO		
Fork tine length	mm	1220	1370	1524
	ft/in	4'0"	4'6"	5'0"
Ground to top of tine clearance	mm	4186	4186	4186
	ft/in	13'9"	13'9"	13'9"
Reach with lift arms horizontal and forks level	mm	2118	2118	2118
	ft/in	6'11"	6'11"	6'11"
Overall length	mm	8557	8707	8861
	ft/in	28'1"	28'7"	29'1"
Static tipping load with level arms and forks, straight	kg	5408	5272	5136
	lb	11,923	11,623	11,323
Static tipping load with level arms and forks, full 40° turn	kg	4620	4501	4382
	lb	10,185	9923	9661
Operating weight	kg	12 907	12 928	12 950
	lb	28,455	28,501	28,550

		Construction Forks – Fusion	
Fork tine length	mm	1524	1829
	ft/in	5'0"	6'0"
Ground to top of tine clearance	mm	4123	4123
	ft/in	13'6"	13'6"
Reach with lift arms horizontal and forks level	mm	2150	2150
	ft/in	7'1"	7'1"
Overall length	mm	8936	9241
	ft/in	29'4"	30'4"
Static tipping load with level arms and forks, straight	kg	4856	4614
	lb	10,706	10,172
Static tipping load with level arms and forks, full 40° turn	kg	4108	3897
	lb	9057	8591
Operating weight	kg	13 372	13 416
	lb	29,480	29,577

\*Meets Tier 4 Final/Stage IV/Japan 2014 (Tier 4 Final) emission standards.

NOTE: Dimensions listed are for a machine configured with attachment, counterweights, additional guarding, 80 kg (176 lb) operator, and Michelin 20.5 R25 (L-3) XHA2 tires.

# Wheel Loaders Integrated Toolcarriers

- ## Performance Data
- 926M\* High Lift
  - Material Handling Arm

Handling Arm Position		Material Handling Arm – Fusion		
		Retracted	Mid-position	Extended
Operating load	kg	1631	1406	1235
	lb	<b>3596</b>	<b>3099</b>	<b>2723</b>
Static tipping load, straight	kg	3740	3224	2832
	lb	<b>8245</b>	<b>7108</b>	<b>6243</b>
Static tipping load, full 40° turn	kg	3262	2811	2470
	lb	<b>7191</b>	<b>6197</b>	<b>5445</b>
Operating weight	kg	12 904	12 904	12 904
	lb	<b>28,448</b>	<b>28,448</b>	<b>28,448</b>

\*Meets Tier 4 Final/Stage IV/Japan 2014 (Tier 4 Final) emission standards.

**NOTE:** Dimensions listed are for a machine configured with attachment, counterweights, additional guarding, 80 kg (**176 lb**) operator, and Michelin 20.5 R25 (L-3) XHA2 tires.

Bucket Type	General Purpose										
		Bolt-on Cutting Edges			Bolt-on Teeth & Segments			Bolt-on Teeth			
Ground Engaging Type											
	Rated bucket capacity	m <sup>3</sup>	2.10	2.30	2.50	2.10	2.30	2.50	2.00	2.20	2.40
		yd <sup>3</sup>	<b>2.75</b>	<b>3.01</b>	<b>3.27</b>	<b>2.75</b>	<b>3.01</b>	<b>3.27</b>	<b>2.62</b>	<b>2.88</b>	<b>3.14</b>
Struck capacity		m <sup>3</sup>	1.90	2.10	2.30	1.90	2.10	2.30	1.80	2.00	2.20
		yd <sup>3</sup>	<b>2.49</b>	<b>2.75</b>	<b>3.01</b>	<b>2.49</b>	<b>2.75</b>	<b>3.01</b>	<b>2.35</b>	<b>2.62</b>	<b>2.88</b>
Bucket width		mm	2550	2550	2550	2550	2550	2550	2550	2550	
		ft/in	<b>8'4"</b>	<b>8'4"</b>	<b>8'4"</b>	<b>8'4"</b>	<b>8'4"</b>	<b>8'4"</b>	<b>8'4"</b>	<b>8'4"</b>	
Dump clearance at full lift and 45° discharge		mm	2855	2807	2761	2751	2702	2655	2751	2702	2655
		ft/in	<b>9'4"</b>	<b>9'3"</b>	<b>9'1"</b>	<b>9'0"</b>	<b>8'10"</b>	<b>8'9"</b>	<b>9'0"</b>	<b>8'10"</b>	<b>8'9"</b>
Reach at full lift and 45° discharge		mm	1033	1070	1109	1135	1172	1210	1135	1172	1210
		ft/in	<b>3'5"</b>	<b>3'6"</b>	<b>3'8"</b>	<b>3'9"</b>	<b>3'10"</b>	<b>4'0"</b>	<b>3'9"</b>	<b>3'10"</b>	<b>4'0"</b>
Reach at 45° discharge and 2130 mm (7'0") clearance		mm	1560	1573	1587	1608	1617	1627	1608	1617	1627
		ft/in	<b>5'1"</b>	<b>5'2"</b>	<b>5'2"</b>	<b>5'3"</b>	<b>5'4"</b>	<b>5'4"</b>	<b>5'3"</b>	<b>5'4"</b>	<b>5'4"</b>
Reach with lift arms horizontal and bucket level		mm	2350	2413	2475	2496	2559	2621	2496	2559	2621
		ft/in	<b>7'9"</b>	<b>7'11"</b>	<b>8'1"</b>	<b>8'2"</b>	<b>8'5"</b>	<b>8'7"</b>	<b>8'2"</b>	<b>8'5"</b>	<b>8'7"</b>
Digging depth		mm	100	100	100	111	111	111	111	111	
		in	<b>3.9</b>	<b>3.9</b>	<b>3.9</b>	<b>4.4</b>	<b>4.4</b>	<b>4.4</b>	<b>4.4</b>	<b>4.4</b>	
Overall length		mm	7488	7551	7613	7634	7697	7759	7614	7677	7739
		ft/in	<b>24'7"</b>	<b>24'9"</b>	<b>25'0"</b>	<b>25'1"</b>	<b>25'3"</b>	<b>25'5"</b>	<b>25'0"</b>	<b>25'2"</b>	<b>25'5"</b>
Overall height with bucket at full raise		mm	5122	5180	5239	5122	5180	5239	5122	5180	5239
		ft/in	<b>16'10"</b>	<b>17'0"</b>	<b>17'2"</b>	<b>16'10"</b>	<b>17'0"</b>	<b>17'2"</b>	<b>16'10"</b>	<b>17'0"</b>	<b>17'2"</b>
Loader clearance radius with bucket in carry position		mm	5933	5951	5970	5980	5999	6018	5980	5999	6018
		ft/in	<b>19'6"</b>	<b>19'6"</b>	<b>19'7"</b>	<b>19'7"</b>	<b>19'8"</b>	<b>19'9"</b>	<b>19'7"</b>	<b>19'8"</b>	<b>19'9"</b>
Static tipping load straight		kg	10 370	10 258	10 119	10 221	10 107	9967	10 323	10 210	10 071
		lb	<b>22,862</b>	<b>22,615</b>	<b>22,309</b>	<b>22,533</b>	<b>22,282</b>	<b>21,973</b>	<b>22,758</b>	<b>22,509</b>	<b>22,203</b>
Static tipping load with 40° turn		kg	8873	8769	8639	8727	8621	8489	8827	8722	8591
		lb	<b>19,562</b>	<b>19,332</b>	<b>19,046</b>	<b>19,240</b>	<b>19,006</b>	<b>18,715</b>	<b>19,460</b>	<b>19,229</b>	<b>18,940</b>
Breakout force		kg	12 881	12 158	11 488	12 760	12 037	11 367	13 687	12 871	12 120
		lbf	<b>28,398</b>	<b>26,804</b>	<b>25,327</b>	<b>28,131</b>	<b>26,537</b>	<b>25,060</b>	<b>30,175</b>	<b>28,376</b>	<b>26,720</b>
Operating weight		kg	13 627	13 691	13 789	13 748	13 811	13 910	13 665	13 729	13 828
		lb	<b>30,042</b>	<b>30,183</b>	<b>30,400</b>	<b>30,309</b>	<b>30,448</b>	<b>30,666</b>	<b>30,126</b>	<b>30,267</b>	<b>30,485</b>

\*Meets Tier 4 Final/Stage IV/Japan 2014 (Tier 4 Final) emission standards.

NOTE: Specifications and ratings conform to all applicable standards recommended by the Society of Automotive Engineers (SAE), including SAE Standards J732 (APR07) which governs loader ratings.



# Wheel Loaders Integrated Toolcarriers

## Performance Data ● 930M\* Standard Lift Pin On Bucket

Bucket Type	Light Material									
		Bolt-on Cutting Edges			Bolt-on Teeth & Segments			Bolt-on Teeth		
Ground Engaging Type										
Rated bucket capacity	m <sup>3</sup>	3.50	4.20	5.00	3.50	4.20	5.00	3.40	4.10	4.90
	yd <sup>3</sup>	<b>4.58</b>	<b>5.49</b>	<b>6.54</b>	<b>4.58</b>	<b>5.49</b>	<b>6.54</b>	<b>4.45</b>	<b>5.36</b>	<b>6.41</b>
Struck capacity	m <sup>3</sup>	3.30	4.00	4.80	3.30	4.00	4.80	3.20	3.90	4.70
	yd <sup>3</sup>	<b>4.32</b>	<b>5.23</b>	<b>6.28</b>	<b>4.32</b>	<b>5.23</b>	<b>6.28</b>	<b>4.19</b>	<b>5.10</b>	<b>6.15</b>
Bucket width	mm	2750	2750	2750	2750	2750	2750	2750	2750	2750
	ft/in	<b>9'0"</b>	<b>9'0"</b>	<b>9'0"</b>	<b>9'0"</b>	<b>9'0"</b>	<b>9'0"</b>	<b>9'0"</b>	<b>9'0"</b>	<b>9'0"</b>
Dump clearance at full lift and 45° discharge	mm	2629	2509	2509	2518	2398	2398	2518	2398	2398
	ft/in	<b>8'8"</b>	<b>8'3"</b>	<b>8'3"</b>	<b>8'3"</b>	<b>7'10"</b>	<b>7'10"</b>	<b>8'3"</b>	<b>7'10"</b>	<b>7'10"</b>
Reach at full lift and 45° discharge	mm	1137	1257	1257	1232	1352	1352	1232	1352	1352
	ft/in	<b>3'9"</b>	<b>4'1"</b>	<b>4'1"</b>	<b>4'1"</b>	<b>4'5"</b>	<b>4'5"</b>	<b>4'1"</b>	<b>4'5"</b>	<b>4'5"</b>
Reach at 45° discharge and 2130 mm (7'0") clearance	mm	1538	1579	1579	1560	1592	1592	1560	1592	1592
	ft/in	<b>5'1"</b>	<b>5'2"</b>	<b>5'2"</b>	<b>5'1"</b>	<b>5'3"</b>	<b>5'3"</b>	<b>5'1"</b>	<b>5'3"</b>	<b>5'3"</b>
Reach with lift arms horizontal and bucket level	mm	2603	2773	2773	2749	2919	2919	2749	2919	2919
	ft/in	<b>8'6"</b>	<b>9'1"</b>	<b>9'1"</b>	<b>9'0"</b>	<b>9'7"</b>	<b>9'7"</b>	<b>9'0"</b>	<b>9'7"</b>	<b>9'7"</b>
Digging depth	mm	100	100	100	111	111	111	111	111	111
	in	<b>3.9</b>	<b>3.9</b>	<b>3.9</b>	<b>4.4</b>	<b>4.4</b>	<b>4.4</b>	<b>4.4</b>	<b>4.4</b>	<b>4.4</b>
Overall length	mm	7741	7911	7911	7887	8057	8057	7867	8037	8037
	ft/in	<b>25'5"</b>	<b>25'11"</b>	<b>25'11"</b>	<b>25'11"</b>	<b>26'5"</b>	<b>26'5"</b>	<b>25'10"</b>	<b>26'4"</b>	<b>26'4"</b>
Overall height with bucket at full raise	mm	5284	5445	5725	5284	5445	5725	5284	5445	5725
	ft/in	<b>17'4"</b>	<b>17'10"</b>	<b>18'9"</b>	<b>17'4"</b>	<b>17'10"</b>	<b>18'9"</b>	<b>17'4"</b>	<b>17'10"</b>	<b>18'9"</b>
Loader clearance radius with bucket in carry position	mm	6099	6152	6152	6148	6202	6202	6148	6202	6202
	ft/in	<b>20'0"</b>	<b>20'2"</b>	<b>20'2"</b>	<b>20'2"</b>	<b>20'4"</b>	<b>20'4"</b>	<b>20'2"</b>	<b>20'4"</b>	<b>20'4"</b>
Static tipping load straight	kg	9796	9512	9474	9653	9366	9328	9759	9474	9437
	lb	<b>21,596</b>	<b>20,970</b>	<b>20,887</b>	<b>21,281</b>	<b>20,648</b>	<b>20,565</b>	<b>21,515</b>	<b>20,887</b>	<b>20,805</b>
Static tipping load with 40° turn	kg	8337	8077	8038	8197	7934	7895	8301	8040	8001
	lb	<b>18,380</b>	<b>17,807</b>	<b>17,721</b>	<b>18,071</b>	<b>17,491</b>	<b>17,405</b>	<b>18,301</b>	<b>17,725</b>	<b>17,639</b>
Breakout force	kg	10 277	9020	8969	10 165	8908	8857	10 786	9406	9353
	lbf	<b>22,657</b>	<b>19,886</b>	<b>19,773</b>	<b>22,410</b>	<b>19,639</b>	<b>19,526</b>	<b>23,779</b>	<b>20,737</b>	<b>20,620</b>
Operating weight	kg	14 004	14 134	14 214	14 115	14 245	14 325	14 033	14 163	14 243
	lb	<b>30,873</b>	<b>31,160</b>	<b>31,336</b>	<b>31,118</b>	<b>31,405</b>	<b>31,581</b>	<b>30,937</b>	<b>31,224</b>	<b>31,400</b>

\*Meets Tier 4 Final/Stage IV/Japan 2014 (Tier 4 Final) emission standards.

**NOTE:** Specifications and ratings conform to all applicable standards recommended by the Society of Automotive Engineers (SAE), including SAE Standards J732 (APR07) which governs loader ratings.

	Change in Operating Weight		Change in Articulated Static Tipping Load	
	kg	lb	kg	lb
Without Ride Control System .....	- 31	- 68	- 14	- 31
Without Guard, driveshaft .....	- 43	- 95	- 16	- 36
With Guard, windshield .....	41	90	24	53
Without Rooding Fenders .....	- 41	- 90	- 31	- 69
Without Secondary Steering .....	- 53	- 117	- 54	- 118
Without Guard, crankcase .....	- 11	- 24	- 15	- 34
Without Guard, power train .....	- 67	- 148	- 65	- 143
With Guard, power train side .....	11	24	10	22
Without Counterweight, Heavy .....	- 343	- 756	- 577	- 1273
With Counterweight, Logger .....	298	656	415	914
With Cold Start 120V .....	54	119	93	205
With Product Link .....	8	18	8	18
With Guard, rear wastegate .....	263	580	472	1041
<b>Tires, 1-piece rims</b>				
17.5-25, Radial (L-2) VUT .....	- 437	- 963	- 533	- 1175
17.5-25, Radial (L-3) VMT .....	- 377	- 831	- 460	- 1014
17.5-25, Radial (L-2) XTLA .....	- 569	- 1254	- 694	- 1530
17.5-25, Radial (L-3) XHA .....	- 481	- 1060	- 587	- 1294
<b>Tires, 3-piece rims</b>				
17.5-25, 16PR (L-2) .....	- 494	- 1089	- 603	- 1329
17.5-25, 16PR (L-3) .....	- 487	- 1074	- 594	- 1310
17.5-25, Radial (L-2) VUT .....	- 386	- 851	- 471	- 1038
17.5-25, Radial (L-3) VMT .....	- 326	- 719	- 398	- 877
550/65 R25, Radial (L-3) .....	- 108	- 238	- 132	- 291
600/65 R25, Radial (L-3) .....	24	53	29	64
20.5-25, 16PR (L-3) .....	- 104	- 229	- 127	- 280
20.5 R25, Radial (L-5) XMINE D2 .....	616	1358	751	1656
20.5 R25, Radial (L-2) VUT .....	- 232	- 511	- 283	- 624
20.5 R25, Radial (L-3) VJT .....	32	71	39	86
20.5 R25, Radial (L-3) VMT .....	56	123	68	150

\*Meets Tier 4 Final/Stage IV/Japan 2014 (Tier 4 Final) emission standards.

# Wheel Loaders Integrated Toolcarriers

## Performance Data ● 930M\* High Lift Pin On Bucket

Bucket Type		General Purpose								
		Bolt-on Cutting Edges			Bolt-on Teeth & Segments			Bolt-on Teeth		
Ground Engaging Type										
Rated bucket capacity	m <sup>3</sup>	2.10	2.30	2.50	2.10	2.30	2.50	2.00	2.20	2.40
	yd <sup>3</sup>	<b>2.75</b>	<b>3.01</b>	<b>3.27</b>	<b>2.75</b>	<b>3.01</b>	<b>3.27</b>	<b>2.62</b>	<b>2.88</b>	<b>3.14</b>
Struck capacity	m <sup>3</sup>	1.90	2.10	2.30	1.90	2.10	2.30	1.80	2.00	2.20
	yd <sup>3</sup>	<b>2.49</b>	<b>2.75</b>	<b>3.01</b>	<b>2.49</b>	<b>2.75</b>	<b>3.01</b>	<b>2.35</b>	<b>2.62</b>	<b>2.88</b>
Bucket width	mm	2550	2550	2550	2550	2550	2550	2550	2550	2550
	ft/in	<b>8'4"</b>	<b>8'4"</b>	<b>8'4"</b>	<b>8'4"</b>	<b>8'4"</b>	<b>8'4"</b>	<b>8'4"</b>	<b>8'4"</b>	<b>8'4"</b>
Dump clearance at full lift and 45° discharge	mm	3448	3400	3353	3344	3295	3247	3344	3295	3247
	ft/in	<b>11'4"</b>	<b>11'2"</b>	<b>11'0"</b>	<b>11'0"</b>	<b>10'10"</b>	<b>10'8"</b>	<b>11'0"</b>	<b>10'10"</b>	<b>10'8"</b>
Reach at full lift and 45° discharge	mm	1353	1391	1429	1456	1492	1530	1456	1492	1530
	ft/in	<b>4'5"</b>	<b>4'7"</b>	<b>4'8"</b>	<b>4'9"</b>	<b>4'11"</b>	<b>5'0"</b>	<b>4'9"</b>	<b>4'11"</b>	<b>5'0"</b>
Reach at 45° discharge and 2130 mm (7'0") clearance	mm	2271	2290	2310	2332	2348	2365	2332	2348	2365
	ft/in	<b>7'5"</b>	<b>7'6"</b>	<b>7'7"</b>	<b>7'8"</b>	<b>7'8"</b>	<b>7'9"</b>	<b>7'8"</b>	<b>7'8"</b>	<b>7'9"</b>
Reach with lift arms horizontal and bucket level	mm	3003	3066	3128	3149	3212	3274	3149	3212	3274
	ft/in	<b>9'10"</b>	<b>10'1"</b>	<b>10'3"</b>	<b>10'4"</b>	<b>10'6"</b>	<b>10'9"</b>	<b>10'4"</b>	<b>10'6"</b>	<b>10'9"</b>
Digging depth	mm	135	135	135	146	146	146	146	146	146
	in	<b>5.3</b>	<b>5.3</b>	<b>5.3</b>	<b>5.7</b>	<b>5.7</b>	<b>5.7</b>	<b>5.7</b>	<b>5.7</b>	<b>5.7</b>
Overall length	mm	8282	8345	8407	8428	8491	8553	8413	8476	8538
	ft/in	<b>27'2"</b>	<b>27'5"</b>	<b>27'7"</b>	<b>27'8"</b>	<b>27'10"</b>	<b>28'1"</b>	<b>27'7"</b>	<b>27'10"</b>	<b>28'0"</b>
Overall height with bucket at full raise	mm	5715	5773	5832	5715	5773	5832	5715	5773	5832
	ft/in	<b>18'9"</b>	<b>18'11"</b>	<b>19'2"</b>	<b>18'9"</b>	<b>18'11"</b>	<b>19'2"</b>	<b>18'9"</b>	<b>18'11"</b>	<b>19'2"</b>
Loader clearance radius with bucket in carry position	mm	6315	6335	6356	6368	6389	6411	6368	6389	6411
	ft/in	<b>20'9"</b>	<b>20'9"</b>	<b>20'10"</b>	<b>20'11"</b>	<b>21'0"</b>	<b>21'0"</b>	<b>20'11"</b>	<b>21'0"</b>	<b>21'0"</b>
Static tipping load straight	kg	7525	7435	7316	7384	7293	7172	7481	7390	7271
	lb	<b>16,590</b>	<b>16,391</b>	<b>16,129</b>	<b>16,279</b>	<b>16,078</b>	<b>15,812</b>	<b>16,493</b>	<b>16,292</b>	<b>16,030</b>
Static tipping load with 40° turn	kg	6383	6298	6184	6244	6158	6043	6339	6254	6140
	lb	<b>14,072</b>	<b>13,885</b>	<b>13,633</b>	<b>13,766</b>	<b>13,576</b>	<b>13,323</b>	<b>13,975</b>	<b>13,788</b>	<b>13,536</b>
Breakout force	kg	12 565	11 859	11 204	12 445	11 739	11 083	13 351	12 553	11 819
	lbf	<b>27,701</b>	<b>26,145</b>	<b>24,701</b>	<b>27,437</b>	<b>25,880</b>	<b>24,434</b>	<b>29,434</b>	<b>27,675</b>	<b>26,057</b>
Operating weight	kg	13 859	13 923	14 022	13 980	14 043	14 142	13 897	13 961	14 060
	lb	<b>30,554</b>	<b>30,695</b>	<b>30,913</b>	<b>30,821</b>	<b>30,959</b>	<b>31,178</b>	<b>30,638</b>	<b>30,779</b>	<b>30,997</b>

\*Meets Tier 4 Final/Stage IV/Japan 2014 (Tier 4 Final) emission standards.

**NOTE:** Specifications and ratings conform to all applicable standards recommended by the Society of Automotive Engineers (SAE), including SAE Standards J732 (APR07) which governs loader ratings.

Bucket Type	Light Material									
	Ground Engaging Type	Bolt-on Cutting Edges			Bolt-on Teeth & Segments			Bolt-on Teeth		
Rated bucket capacity		m <sup>3</sup>	3.50	4.20	5.00	3.50	4.20	5.00	3.40	4.10
	yd <sup>3</sup>	<b>4.58</b>	<b>5.49</b>	<b>6.54</b>	<b>4.58</b>	<b>5.49</b>	<b>6.54</b>	<b>4.45</b>	<b>5.36</b>	<b>6.41</b>
Struck capacity	m <sup>3</sup>	3.30	4.00	4.80	3.30	4.00	4.80	3.20	3.90	4.70
	yd <sup>3</sup>	<b>4.32</b>	<b>5.23</b>	<b>6.28</b>	<b>4.32</b>	<b>5.23</b>	<b>6.28</b>	<b>4.19</b>	<b>5.10</b>	<b>6.15</b>
Bucket width	mm	2750	2750	2750	2750	2750	2750	2750	2750	2750
	ft/in	<b>9'0"</b>	<b>9'0"</b>	<b>9'0"</b>	<b>9'0"</b>	<b>9'0"</b>	<b>9'0"</b>	<b>9'0"</b>	<b>9'0"</b>	<b>9'0"</b>
Dump clearance at full lift and 45° discharge	mm	3222	3102	3102	3111	2991	2991	3111	2991	2991
	ft/in	<b>10'7"</b>	<b>10'2"</b>	<b>10'2"</b>	<b>10'2"</b>	<b>9'10"</b>	<b>9'10"</b>	<b>10'2"</b>	<b>9'10"</b>	<b>9'10"</b>
Reach at full lift and 45° discharge	mm	1457	1577	1577	1552	1672	1672	1552	1672	1672
	ft/in	<b>4'9"</b>	<b>5'2"</b>	<b>5'2"</b>	<b>5'1"</b>	<b>5'6"</b>	<b>5'6"</b>	<b>5'1"</b>	<b>5'6"</b>	<b>5'6"</b>
Reach at 45° discharge and 2130 mm (7'0") clearance	mm	2280	2340	2340	2320	2375	2375	2320	2375	2375
	ft/in	<b>7'6"</b>	<b>7'8"</b>	<b>7'8"</b>	<b>7'7"</b>	<b>7'10"</b>	<b>7'10"</b>	<b>7'7"</b>	<b>7'10"</b>	<b>7'10"</b>
Reach with lift arms horizontal and bucket level	mm	3256	3426	3426	3402	3572	3572	3402	3572	3572
	ft/in	<b>10'8"</b>	<b>11'3"</b>	<b>11'3"</b>	<b>11'2"</b>	<b>11'9"</b>	<b>11'9"</b>	<b>11'2"</b>	<b>11'9"</b>	<b>11'9"</b>
Digging depth	mm	135	135	135	146	146	146	146	146	146
	in	<b>5.3</b>	<b>5.3</b>	<b>5.3</b>	<b>5.7</b>	<b>5.7</b>	<b>5.7</b>	<b>5.7</b>	<b>5.7</b>	<b>5.7</b>
Overall length	mm	8535	8705	8705	8681	8851	8851	8666	8836	8836
	ft/in	<b>28'0"</b>	<b>28'7"</b>	<b>28'7"</b>	<b>28'6"</b>	<b>29'0"</b>	<b>29'0"</b>	<b>28'5"</b>	<b>29'0"</b>	<b>29'0"</b>
Overall height with bucket at full raise	mm	5877	6038	6317	5877	6038	6317	5877	6038	6317
	ft/in	<b>19'3"</b>	<b>19'10"</b>	<b>20'9"</b>	<b>19'3"</b>	<b>19'10"</b>	<b>20'9"</b>	<b>19'3"</b>	<b>19'10"</b>	<b>20'9"</b>
Loader clearance radius with bucket in carry position	mm	6484	6542	6542	6539	6598	6598	6539	6598	6598
	ft/in	<b>21'3"</b>	<b>21'6"</b>	<b>21'6"</b>	<b>21'5"</b>	<b>21'8"</b>	<b>21'8"</b>	<b>21'5"</b>	<b>21'8"</b>	<b>21'8"</b>
Static tipping load straight	kg	7046	6830	6781	6911	6693	6643	7011	6794	6745
	lb	<b>15,534</b>	<b>15,058</b>	<b>14,950</b>	<b>15,236</b>	<b>14,756</b>	<b>14,645</b>	<b>15,457</b>	<b>14,978</b>	<b>14,870</b>
Static tipping load with 40° turn	kg	5928	5727	5678	5796	5593	5543	5894	5693	5643
	lb	<b>13,069</b>	<b>12,626</b>	<b>12,518</b>	<b>12,778</b>	<b>12,330</b>	<b>12,220</b>	<b>12,994</b>	<b>12,551</b>	<b>12,441</b>
Breakout force	kg	10 019	8791	8740	9908	8679	8628	10 515	9166	9113
	lbf	<b>22,088</b>	<b>19,381</b>	<b>19,269</b>	<b>21,844</b>	<b>19,134</b>	<b>19,022</b>	<b>23,182</b>	<b>20,208</b>	<b>20,091</b>
Operating weight	kg	14 236	14 366	14 446	14 347	14 477	14 557	14 265	14 395	14 475
	lb	<b>31,385</b>	<b>31,672</b>	<b>31,848</b>	<b>31,630</b>	<b>31,916</b>	<b>32,093</b>	<b>31,449</b>	<b>31,736</b>	<b>31,912</b>

\*Meets Tier 4 Final/Stage IV/Japan 2014 (Tier 4 Final) emission standards.

NOTE: Specifications and ratings conform to all applicable standards recommended by the Society of Automotive Engineers (SAE), including SAE Standards J732 (APR07) which governs loader ratings.

	Change in Operating Weight		Change in Articulated Static Tipping Load	
	kg	lb	kg	lb
Without Ride Control System .....	- 31	- 68	- 11	- 23
Without Guard, driveshaft .....	- 43	- 95	- 13	- 28
With Guard, windshield .....	41	90	18	41
Without Rooding Fenders .....	- 41	- 90	- 24	- 53
Without Secondary Steering .....	- 53	- 117	- 41	- 91
Without Guard, crankcase .....	- 11	- 24	- 12	- 26
Without Guard, power train .....	- 67	- 148	- 50	- 110
With Guard, power train side .....	11	24	8	17
Without Counterweight, Heavy .....	- 343	- 756	- 444	- 980
With Cold Start 120V .....	54	119	72	158
With Product Link .....	8	18	6	14
With Guard, rear wastegate .....	263	580	363	800
<b>Tires, 1-piece rims</b>				
17.5-25, Radial (L-2) VUT .....	- 437	- 963	- 411	- 906
17.5-25, Radial (L-3) VMT .....	- 377	- 831	- 354	- 780
17.5-25, Radial (L-2) XTLA .....	- 569	- 1254	- 534	- 1177
17.5-25, Radial (L-3) XHA .....	- 481	- 1060	- 452	- 996
<b>Tires, 3-piece rims</b>				
17.5-25, 16PR (L-2) .....	- 494	- 1089	- 464	- 1023
17.5-25, 16PR (L-3) .....	- 487	- 1074	- 457	- 1008
17.5-25, Radial (L-2) VUT .....	- 386	- 851	- 363	- 800
17.5-25, Radial (L-3) VMT .....	- 326	- 719	- 306	- 675
550/65 R25, Radial (L-3) .....	- 108	- 238	- 101	- 223
600/65 R25, Radial (L-3) .....	24	53	23	51
20.5-25, 16PR (L-3) .....	- 104	- 229	- 98	- 216
20.5 R25, Radial (L-5) XMINE D2 .....	616	1358	578	1274
20.5 R25, Radial (L-2) VUT .....	- 232	- 511	- 218	- 481
20.5 R25, Radial (L-3) VJT .....	32	71	30	66
20.5 R25, Radial (L-3) VMT .....	56	123	53	117

\*Meets Tier 4 Final/Stage IV/Japan 2014 (Tier 4 Final) emission standards.

Bucket Type	General Purpose										
		Bolt-on Cutting Edges			Bolt-on Teeth & Segments			Bolt-on Teeth			
Ground Engaging Type											
	Rated bucket capacity	m <sup>3</sup>	2.10	2.30	2.50	2.10	2.30	2.50	2.00	2.20	2.40
		yd <sup>3</sup>	<b>2.75</b>	<b>3.01</b>	<b>3.27</b>	<b>2.75</b>	<b>3.01</b>	<b>3.27</b>	<b>2.62</b>	<b>2.88</b>	<b>3.14</b>
Struck capacity		m <sup>3</sup>	1.90	2.10	2.30	1.90	2.10	2.30	1.80	2.00	2.20
		yd <sup>3</sup>	<b>2.49</b>	<b>2.75</b>	<b>3.01</b>	<b>2.49</b>	<b>2.75</b>	<b>3.01</b>	<b>2.35</b>	<b>2.62</b>	<b>2.88</b>
Bucket width		mm	2550	2550	2550	2550	2550	2550	2550	2550	
		ft/in	<b>8'4"</b>	<b>8'4"</b>	<b>8'4"</b>	<b>8'4"</b>	<b>8'4"</b>	<b>8'4"</b>	<b>8'4"</b>	<b>8'4"</b>	
Dump clearance at full lift and 45° discharge		mm	2828	2779	2733	2723	2674	2627	2723	2674	2627
		ft/in	<b>9'3"</b>	<b>9'1"</b>	<b>9'0"</b>	<b>8'11"</b>	<b>8'9"</b>	<b>8'7"</b>	<b>8'11"</b>	<b>8'9"</b>	<b>8'7"</b>
Reach at full lift and 45° discharge		mm	1064	1102	1140	1167	1204	1241	1167	1204	1241
		ft/in	<b>3'6"</b>	<b>3'7"</b>	<b>3'9"</b>	<b>3'10"</b>	<b>3'11"</b>	<b>4'1"</b>	<b>3'10"</b>	<b>3'11"</b>	<b>4'1"</b>
Reach at 45° discharge and 2130 mm (7'0") clearance		mm	1578	1590	1603	1624	1632	1641	1624	1632	1641
		ft/in	<b>5'2"</b>	<b>5'3"</b>	<b>5'3"</b>	<b>5'4"</b>	<b>5'4"</b>	<b>5'5"</b>	<b>5'4"</b>	<b>5'4"</b>	<b>5'5"</b>
Reach with lift arms horizontal and bucket level		mm	2392	2455	2517	2538	2601	2663	2538	2601	2663
		ft/in	<b>7'10"</b>	<b>8'1"</b>	<b>8'3"</b>	<b>8'4"</b>	<b>8'6"</b>	<b>8'9"</b>	<b>8'4"</b>	<b>8'6"</b>	<b>8'9"</b>
Digging depth		mm	100	100	100	111	111	111	111	111	
		in	<b>3.9</b>	<b>3.9</b>	<b>3.9</b>	<b>4.4</b>	<b>4.4</b>	<b>4.4</b>	<b>4.4</b>	<b>4.4</b>	
Overall length		mm	7530	7593	7655	7676	7739	7801	7655	7718	7780
		ft/in	<b>24'8"</b>	<b>24'11"</b>	<b>25'1"</b>	<b>25'2"</b>	<b>25'5"</b>	<b>25'7"</b>	<b>25'1"</b>	<b>25'4"</b>	<b>25'6"</b>
Overall height with bucket at full raise		mm	5147	5205	5264	5147	5205	5264	5147	5205	5264
		ft/in	<b>16'11"</b>	<b>17'1"</b>	<b>17'3"</b>	<b>16'11"</b>	<b>17'1"</b>	<b>17'3"</b>	<b>16'11"</b>	<b>17'1"</b>	<b>17'3"</b>
Loader clearance radius with bucket in carry position		mm	5945	5964	5983	5993	6012	6032	5993	6012	6032
		ft/in	<b>19'6"</b>	<b>19'7"</b>	<b>19'8"</b>	<b>19'8"</b>	<b>19'9"</b>	<b>19'9"</b>	<b>19'8"</b>	<b>19'9"</b>	<b>19'9"</b>
Static tipping load straight		kg	9941	9855	9734	9792	9704	9582	9893	9807	9686
		lb	<b>21,916</b>	<b>21,727</b>	<b>21,460</b>	<b>21,588</b>	<b>21,394</b>	<b>21,125</b>	<b>21,810</b>	<b>21,621</b>	<b>21,354</b>
Static tipping load with 40° turn		kg	8469	8390	8278	8323	8243	8129	8423	8344	8231
		lb	<b>18,671</b>	<b>18,497</b>	<b>18,250</b>	<b>18,349</b>	<b>18,173</b>	<b>17,921</b>	<b>18,570</b>	<b>18,395</b>	<b>18,146</b>
Breakout force		kg	12 366	11 693	11 063	12 245	11 573	10 942	13 106	12 350	11 647
		lbf	<b>27,263</b>	<b>25,779</b>	<b>24,390</b>	<b>26,996</b>	<b>25,514</b>	<b>24,123</b>	<b>28,894</b>	<b>27,227</b>	<b>25,677</b>
Operating weight		kg	14 007	14 044	14 127	14 127	14 165	14 247	14 045	14 082	14 165
		lb	<b>30,880</b>	<b>30,962</b>	<b>31,145</b>	<b>31,145</b>	<b>31,228</b>	<b>31,409</b>	<b>30,964</b>	<b>31,045</b>	<b>31,228</b>

\*Meets Tier 4 Final/Stage IV/Japan 2014 (Tier 4 Final) emission standards.

NOTE: Specifications and ratings conform to all applicable standards recommended by the Society of Automotive Engineers (SAE), including SAE Standards J732 (APR07) which governs loader ratings.

# Wheel Loaders Integrated Toolcarriers

## Performance Data ● 930M\* Standard Lift Fusion Bucket

Bucket Type	Light Material									
		Bolt-on Cutting Edges			Bolt-on Teeth & Segments			Bolt-on Teeth		
Ground Engaging Type										
Rated bucket capacity	m <sup>3</sup>	3.50	4.20	5.00	3.50	4.20	5.00	3.40	4.10	4.90
	yd <sup>3</sup>	<b>4.58</b>	<b>5.49</b>	<b>6.54</b>	<b>4.58</b>	<b>5.49</b>	<b>6.54</b>	<b>4.45</b>	<b>5.36</b>	<b>6.41</b>
Struck capacity	m <sup>3</sup>	3.30	4.00	4.80	3.30	4.00	4.80	3.20	3.90	4.70
	yd <sup>3</sup>	<b>4.32</b>	<b>5.23</b>	<b>6.28</b>	<b>4.32</b>	<b>5.23</b>	<b>6.28</b>	<b>4.19</b>	<b>5.10</b>	<b>6.15</b>
Bucket width	mm	2750	2750	2750	2750	2750	2750	2750	2750	2750
	ft/in	<b>9'0"</b>	<b>9'0"</b>	<b>9'0"</b>	<b>9'0"</b>	<b>9'0"</b>	<b>9'0"</b>	<b>9'0"</b>	<b>9'0"</b>	<b>9'0"</b>
Dump clearance at full lift and 45° discharge	mm	2600	2479	2479	2488	2368	2368	2488	2368	2368
	ft/in	<b>8'6"</b>	<b>8'2"</b>	<b>8'2"</b>	<b>8'2"</b>	<b>7'9"</b>	<b>7'9"</b>	<b>8'2"</b>	<b>7'9"</b>	<b>7'9"</b>
Reach at full lift and 45° discharge	mm	1166	1286	1286	1261	1382	1382	1261	1382	1382
	ft/in	<b>3'10"</b>	<b>4'3"</b>	<b>4'3"</b>	<b>4'2"</b>	<b>4'6"</b>	<b>4'6"</b>	<b>4'2"</b>	<b>4'6"</b>	<b>4'6"</b>
Reach at 45° discharge and 2130 mm (7'0") clearance	mm	1549	1588	1588	1569	1598	1598	1569	1598	1598
	ft/in	<b>5'1"</b>	<b>5'3"</b>	<b>5'3"</b>	<b>5'2"</b>	<b>5'3"</b>	<b>5'3"</b>	<b>5'2"</b>	<b>5'3"</b>	<b>5'3"</b>
Reach with lift arms horizontal and bucket level	mm	2645	2815	2815	2791	2961	2961	2791	2961	2961
	ft/in	<b>8'8"</b>	<b>9'3"</b>	<b>9'3"</b>	<b>9'2"</b>	<b>9'9"</b>	<b>9'9"</b>	<b>9'2"</b>	<b>9'9"</b>	<b>9'9"</b>
Digging depth	mm	100	100	100	111	111	111	111	111	111
	in	<b>3.9</b>	<b>3.9</b>	<b>3.9</b>	<b>4.4</b>	<b>4.4</b>	<b>4.4</b>	<b>4.4</b>	<b>4.4</b>	<b>4.4</b>
Overall length	mm	7783	7953	7953	7929	8099	8099	7909	8079	8079
	ft/in	<b>25'6"</b>	<b>26'1"</b>	<b>26'1"</b>	<b>26'0"</b>	<b>26'7"</b>	<b>26'7"</b>	<b>25'11"</b>	<b>26'6"</b>	<b>26'6"</b>
Overall height with bucket at full raise	mm	5309	5471	5752	5309	5471	5752	5309	5471	5752
	ft/in	<b>17'5"</b>	<b>17'11"</b>	<b>18'10"</b>	<b>17'5"</b>	<b>17'11"</b>	<b>18'10"</b>	<b>17'5"</b>	<b>17'11"</b>	<b>18'10"</b>
Loader clearance radius with bucket in carry position	mm	6112	6166	6166	6162	6217	6217	6162	6217	6217
	ft/in	<b>20'1"</b>	<b>20'3"</b>	<b>20'3"</b>	<b>20'3"</b>	<b>20'5"</b>	<b>20'5"</b>	<b>20'3"</b>	<b>20'5"</b>	<b>20'5"</b>
Static tipping load straight	kg	9395	9118	9081	9253	8973	8936	9359	9081	9044
	lb	<b>20,712</b>	<b>20,102</b>	<b>20,020</b>	<b>20,399</b>	<b>19,782</b>	<b>19,700</b>	<b>20,633</b>	<b>20,020</b>	<b>19,939</b>
Static tipping load with 40° turn	kg	7960	7707	7668	7821	7564	7526	7924	7670	7632
	lb	<b>17,549</b>	<b>16,991</b>	<b>16,905</b>	<b>17,242</b>	<b>16,676</b>	<b>16,592</b>	<b>17,469</b>	<b>16,909</b>	<b>16,826</b>
Breakout force	kg	9921	8730	8682	9809	8619	8570	10 394	9091	9040
	lbf	<b>21,872</b>	<b>19,246</b>	<b>19,141</b>	<b>21,625</b>	<b>19,002</b>	<b>18,894</b>	<b>22,915</b>	<b>20,042</b>	<b>19,930</b>
Operating weight	kg	14 367	14 497	14 574	14 478	14 608	14 685	14 396	14 526	14 603
	lb	<b>31,674</b>	<b>31,960</b>	<b>32,130</b>	<b>31,918</b>	<b>32,205</b>	<b>32,375</b>	<b>31,738</b>	<b>32,024</b>	<b>32,194</b>

\*Meets Tier 4 Final/Stage IV/Japan 2014 (Tier 4 Final) emission standards.

**NOTE:** Specifications and ratings conform to all applicable standards recommended by the Society of Automotive Engineers (SAE), including SAE Standards J732 (APR07) which governs loader ratings.

	Change in Operating Weight		Change in Articulated Static Tipping Load	
	kg	lb	kg	lb
Without Ride Control System .....	- 31	- 68	- 14	- 30
Without Guard, driveshaft .....	- 43	- 95	- 16	- 36
With Guard, windshield .....	41	90	24	52
Without Rooding Fenders .....	- 41	- 90	- 31	- 68
Without Secondary Steering .....	- 53	- 117	- 53	- 117
Without Guard, crankcase .....	- 11	- 24	- 15	- 33
Without Guard, power train .....	- 67	- 148	- 64	- 141
With Guard, power train side .....	11	24	10	22
Without Counterweight, Heavy .....	- 343	- 756	- 570	- 1256
With Counterweight, Logger .....	298	656	415	914
With Cold Start 120V .....	54	119	92	202
With Product Link .....	8	18	8	17
With Guard, rear wastegate .....	263	580	466	1027
<b>Tires, 1-piece rims</b>				
17.5-25, Radial (L-2) VUT .....	- 437	- 963	- 527	- 1162
17.5-25, Radial (L-3) VMT .....	- 377	- 831	- 454	- 1001
17.5-25, Radial (L-2) XTLA .....	- 569	- 1254	- 685	- 1510
17.5-25, Radial (L-3) XHA .....	- 481	- 1060	- 580	- 1279
<b>Tires, 3-piece rims</b>				
17.5-25, 16PR (L-2) .....	- 494	- 1089	- 595	- 1312
17.5-25, 16PR (L-3) .....	- 487	- 1074	- 587	- 1294
17.5-25, Radial (L-2) VUT .....	- 386	- 851	- 465	- 1025
17.5-25, Radial (L-3) VMT .....	- 326	- 719	- 393	- 866
550/65 R25, Radial (L-3) .....	- 108	- 238	- 130	- 287
600/65 R25, Radial (L-3) .....	24	53	29	64
20.5-25, 16PR (L-3) .....	- 104	- 229	- 125	- 276
20.5 R25, Radial (L-5) XMINE D2 .....	616	1358	- 742	1636
20.5 R25, Radial (L-2) VUT .....	- 232	- 511	- 279	- 615
20.5 R25, Radial (L-3) VJT .....	32	71	39	86
20.5 R25, Radial (L-3) VMT .....	56	123	67	148

\*Meets Tier 4 Final/Stage IV/Japan 2014 (Tier 4 Final) emission standards.



# Wheel Loaders Integrated Toolcarriers

## Performance Data ● 930M\* High Lift Fusion Bucket

Bucket Type		General Purpose								
		Bolt-on Cutting Edges			Bolt-on Teeth & Segments			Bolt-on Teeth		
Ground Engaging Type										
Rated bucket capacity	m <sup>3</sup>	2.10	2.30	2.50	2.10	2.30	2.50	2.00	2.20	2.40
	yd <sup>3</sup>	<b>2.75</b>	<b>3.01</b>	<b>3.27</b>	<b>2.75</b>	<b>3.01</b>	<b>3.27</b>	<b>2.62</b>	<b>2.88</b>	<b>3.14</b>
Struck capacity	m <sup>3</sup>	1.90	2.10	2.30	1.90	2.10	2.30	1.80	2.00	2.20
	yd <sup>3</sup>	<b>2.49</b>	<b>2.75</b>	<b>3.01</b>	<b>2.49</b>	<b>2.75</b>	<b>3.01</b>	<b>2.35</b>	<b>2.62</b>	<b>2.88</b>
Bucket width	mm	2550	2550	2550	2550	2550	2550	2550	2550	2550
	ft/in	<b>8'4"</b>	<b>8'4"</b>	<b>8'4"</b>	<b>8'4"</b>	<b>8'4"</b>	<b>8'4"</b>	<b>8'4"</b>	<b>8'4"</b>	<b>8'4"</b>
Dump clearance at full lift and 45° discharge	mm	3421	3372	3325	3316	3267	3219	3316	3267	3219
	ft/in	<b>11'3"</b>	<b>11'1"</b>	<b>10'11"</b>	<b>10'11"</b>	<b>10'9"</b>	<b>10'7"</b>	<b>10'11"</b>	<b>10'9"</b>	<b>10'7"</b>
Reach at full lift and 45° discharge	mm	1385	1422	1460	1487	1524	1561	1487	1524	1561
	ft/in	<b>4'7"</b>	<b>4'8"</b>	<b>4'9"</b>	<b>4'11"</b>	<b>5'0"</b>	<b>5'1"</b>	<b>4'11"</b>	<b>5'0"</b>	<b>5'1"</b>
Reach at 45° discharge and 2130 mm (7'0") clearance	mm	2293	2311	2329	2352	2367	2383	2352	2367	2383
	ft/in	<b>7'6"</b>	<b>7'7"</b>	<b>7'8"</b>	<b>7'9"</b>	<b>7'9"</b>	<b>7'10"</b>	<b>7'9"</b>	<b>7'9"</b>	<b>7'10"</b>
Reach with lift arms horizontal and bucket level	mm	3045	3108	3170	3191	3254	3316	3191	3254	3316
	ft/in	<b>10'0"</b>	<b>10'2"</b>	<b>10'5"</b>	<b>10'6"</b>	<b>10'8"</b>	<b>10'11"</b>	<b>10'6"</b>	<b>10'8"</b>	<b>10'11"</b>
Digging depth	mm	135	135	135	146	146	146	146	146	146
	in	<b>5.3</b>	<b>5.3</b>	<b>5.3</b>	<b>5.7</b>	<b>5.7</b>	<b>5.7</b>	<b>5.7</b>	<b>5.7</b>	<b>5.7</b>
Overall length	mm	8324	8387	8449	8470	8533	8595	8455	8518	8580
	ft/in	<b>27'4"</b>	<b>27'6"</b>	<b>27'9"</b>	<b>27'9"</b>	<b>28'0"</b>	<b>28'2"</b>	<b>27'9"</b>	<b>27'11"</b>	<b>28'2"</b>
Overall height with bucket at full raise	mm	5740	5798	5857	5740	5798	5857	5740	5798	5857
	ft/in	<b>18'10"</b>	<b>19'0"</b>	<b>19'3"</b>	<b>18'10"</b>	<b>19'0"</b>	<b>19'3"</b>	<b>18'10"</b>	<b>19'0"</b>	<b>19'3"</b>
Loader clearance radius with bucket in carry position	mm	6329	6350	6371	6383	6404	6426	6383	6404	6426
	ft/in	<b>20'9"</b>	<b>20'10"</b>	<b>20'11"</b>	<b>20'11"</b>	<b>21'0"</b>	<b>21'1"</b>	<b>20'11"</b>	<b>21'0"</b>	<b>21'1"</b>
Static tipping load straight	kg	7139	7074	6973	6998	6932	6829	7094	7029	6928
	lb	<b>15,739</b>	<b>15,595</b>	<b>15,373</b>	<b>15,428</b>	<b>15,282</b>	<b>15,055</b>	<b>15,640</b>	<b>15,496</b>	<b>15,274</b>
Static tipping load with 40° turn	kg	6014	5954	5858	5875	5814	5717	5970	5910	5814
	lb	<b>13,259</b>	<b>13,126</b>	<b>12,915</b>	<b>12,952</b>	<b>12,818</b>	<b>12,604</b>	<b>13,162</b>	<b>13,029</b>	<b>12,818</b>
Breakout force	kg	12 062	11 405	10 788	11 941	11 284	10 667	12 783	12 044	11 356
	lbf	<b>26,592</b>	<b>25,144</b>	<b>23,784</b>	<b>26,326</b>	<b>24,877</b>	<b>23,517</b>	<b>28,182</b>	<b>26,553</b>	<b>25,036</b>
Operating weight	kg	14 239	14 276	14 359	14 359	14 397	14 479	14 277	14 314	14 397
	lb	<b>31,392</b>	<b>31,473</b>	<b>31,656</b>	<b>31,656</b>	<b>31,740</b>	<b>31,921</b>	<b>31,475</b>	<b>31,557</b>	<b>31,740</b>

\*Meets Tier 4 Final/Stage IV/Japan 2014 (Tier 4 Final) emission standards.

**NOTE:** Specifications and ratings conform to all applicable standards recommended by the Society of Automotive Engineers (SAE), including SAE Standards J732 (APR07) which governs loader ratings.

Performance Data  
 ● 930M\* High Lift Fusion Bucket

Wheel Loaders  
 Integrated Toolcarriers

Bucket Type	Light Material									
	Ground Engaging Type	Bolt-on Cutting Edges			Bolt-on Teeth & Segments			Bolt-on Teeth		
Rated bucket capacity		m <sup>3</sup>	3.50	4.20	5.00	3.50	4.20	5.00	3.40	4.10
	yd <sup>3</sup>	<b>4.58</b>	<b>5.49</b>	<b>6.54</b>	<b>4.58</b>	<b>5.49</b>	<b>6.54</b>	<b>4.45</b>	<b>5.36</b>	<b>6.41</b>
Struck capacity	m <sup>3</sup>	3.30	4.00	4.80	3.30	4.00	4.80	3.20	3.90	4.70
	yd <sup>3</sup>	<b>4.32</b>	<b>5.23</b>	<b>6.28</b>	<b>4.32</b>	<b>5.23</b>	<b>6.28</b>	<b>4.19</b>	<b>5.10</b>	<b>6.15</b>
Bucket width	mm	2750	2750	2750	2750	2750	2750	2750	2750	2750
	ft/in	<b>9'0"</b>	<b>9'0"</b>	<b>9'0"</b>	<b>9'0"</b>	<b>9'0"</b>	<b>9'0"</b>	<b>9'0"</b>	<b>9'0"</b>	<b>9'0"</b>
Dump clearance at full lift and 45° discharge	mm	3192	3072	3072	3081	2961	2961	3081	2961	2961
	ft/in	<b>10'6"</b>	<b>10'1"</b>	<b>10'1"</b>	<b>10'1"</b>	<b>9'9"</b>	<b>9'9"</b>	<b>10'1"</b>	<b>9'9"</b>	<b>9'9"</b>
Reach at full lift and 45° discharge	mm	1486	1607	1607	1581	1702	1702	1581	1702	1702
	ft/in	<b>4'11"</b>	<b>5'3"</b>	<b>5'3"</b>	<b>5'2"</b>	<b>5'7"</b>	<b>5'7"</b>	<b>5'2"</b>	<b>5'7"</b>	<b>5'7"</b>
Reach at 45° discharge and 2130 mm (7'0") clearance	mm	2295	2355	2355	2334	2388	2388	2334	2388	2388
	ft/in	<b>7'6"</b>	<b>7'9"</b>	<b>7'9"</b>	<b>7'8"</b>	<b>7'10"</b>	<b>7'10"</b>	<b>7'8"</b>	<b>7'10"</b>	<b>7'10"</b>
Reach with lift arms horizontal and bucket level	mm	3298	3468	3468	3444	3614	3614	3444	3614	3614
	ft/in	<b>10'10"</b>	<b>11'5"</b>	<b>11'5"</b>	<b>11'4"</b>	<b>11'10"</b>	<b>11'10"</b>	<b>11'4"</b>	<b>11'10"</b>	<b>11'10"</b>
Digging depth	mm	135	135	135	146	146	146	146	146	146
	in	<b>5.3</b>	<b>5.3</b>	<b>5.3</b>	<b>5.7</b>	<b>5.7</b>	<b>5.7</b>	<b>5.7</b>	<b>5.7</b>	<b>5.7</b>
Overall length	mm	8577	8747	8747	8723	8893	8893	8708	8878	8878
	ft/in	<b>28'2"</b>	<b>28'8"</b>	<b>28'8"</b>	<b>28'7"</b>	<b>29'2"</b>	<b>29'2"</b>	<b>28'7"</b>	<b>29'2"</b>	<b>29'2"</b>
Overall height with bucket at full raise	mm	5902	6064	6345	5902	6064	6345	5902	6064	6345
	ft/in	<b>19'4"</b>	<b>19'11"</b>	<b>20'10"</b>	<b>19'4"</b>	<b>19'11"</b>	<b>20'10"</b>	<b>19'4"</b>	<b>19'11"</b>	<b>20'10"</b>
Loader clearance radius with bucket in carry position	mm	6499	6557	6557	6554	6613	6613	6554	6613	6613
	ft/in	<b>21'4"</b>	<b>21'6"</b>	<b>21'6"</b>	<b>21'6"</b>	<b>21'8"</b>	<b>21'8"</b>	<b>21'6"</b>	<b>21'8"</b>	<b>21'8"</b>
Static tipping load straight	kg	6684	6472	6424	6549	6335	6287	6649	6437	6389
	lb	<b>14,736</b>	<b>14,268</b>	<b>14,162</b>	<b>14,438</b>	<b>13,966</b>	<b>13,860</b>	<b>14,659</b>	<b>14,191</b>	<b>14,085</b>
Static tipping load with 40° turn	kg	5583	5387	5338	5451	5253	5204	5549	5352	5303
	lb	<b>12,308</b>	<b>11,876</b>	<b>11,768</b>	<b>12,017</b>	<b>11,581</b>	<b>11,473</b>	<b>12,233</b>	<b>11,799</b>	<b>11,691</b>
Breakout force	kg	9670	8506	8458	9559	8395	8347	10 131	8858	8807
	lbf	<b>21,319</b>	<b>18,753</b>	<b>18,647</b>	<b>21,074</b>	<b>18,508</b>	<b>18,402</b>	<b>22,335</b>	<b>19,529</b>	<b>19,416</b>
Operating weight	kg	14 599	14 729	14 807	14 710	14 840	14 917	14 628	14 758	14 835
	lb	<b>32,185</b>	<b>32,472</b>	<b>32,644</b>	<b>32,430</b>	<b>32,717</b>	<b>32,886</b>	<b>32,249</b>	<b>32,536</b>	<b>32,706</b>

\*Meets Tier 4 Final/Stage IV/Japan 2014 (Tier 4 Final) emission standards.

NOTE: Specifications and ratings conform to all applicable standards recommended by the Society of Automotive Engineers (SAE), including SAE Standards J732 (APR07) which governs loader ratings.

	Change in Operating Weight		Change in Articulated Static Tipping Load	
	kg	lb	kg	lb
Without Ride Control System .....	- 31	- 68	- 11	- 23
Without Guard, driveshaft .....	- 43	- 95	- 13	- 28
With Guard, windshield .....	41	90	18	40
Without Rooding Fenders .....	- 41	- 90	- 24	- 52
Without Secondary Steering .....	- 53	- 117	- 41	- 90
Without Guard, crankcase .....	- 11	- 24	- 12	- 26
Without Guard, power train .....	- 67	- 148	- 49	- 109
With Guard, power train side .....	11	24	8	17
Without Counterweight, Heavy .....	- 343	- 756	- 440	- 970
With Cold Start 120V .....	54	119	71	156
With Product Link .....	8	18	6	13
With Guard, rear wastegate .....	263	580	359	791
<b>Tires, 1-piece rims</b>				
17.5-25, Radial (L-2) VUT .....	- 437	- 963	- 406	- 895
17.5-25, Radial (L-3) VMT .....	- 377	- 831	- 351	- 774
17.5-25, Radial (L-2) XTLA .....	- 569	- 1254	- 529	- 1166
17.5-25, Radial (L-3) XHA .....	- 481	- 1060	- 447	- 985
<b>Tires, 3-piece rims</b>				
17.5-25, 16PR (L-2) .....	- 494	- 1089	- 460	- 1014
17.5-25, 16PR (L-3) .....	- 487	- 1074	- 453	- 999
17.5-25, Radial (L-2) VUT .....	- 386	- 851	- 359	- 791
17.5-25, Radial (L-3) VMT .....	- 326	- 719	- 303	- 668
550/65 R25, Radial (L-3) .....	- 108	- 238	- 100	- 220
600/65 R25, Radial (L-3) .....	24	53	22	49
20.5-25, 16PR (L-3) .....	- 104	- 229	- 97	- 214
20.5 R25, Radial (L-5) XMINE D2 .....	616	1358	573	1263
20.5 R25, Radial (L-2) VUT .....	- 232	- 511	- 216	- 476
20.5 R25, Radial (L-3) VJT .....	32	71	30	66
20.5 R25, Radial (L-3) VMT .....	56	123	52	115

\*Meets Tier 4 Final/Stage IV/Japan 2014 (Tier 4 Final) emission standards.

Bucket Type		General Purpose							
		Bolt-on Cutting Edges				Bolt-on Teeth & Segments			
<b>Ground Engaging Type</b>									
Rated bucket capacity	m <sup>3</sup>	2.10	2.30	2.50	2.70	2.10	2.30	2.50	2.70
	yd <sup>3</sup>	<b>2.75</b>	<b>3.01</b>	<b>3.27</b>	<b>3.53</b>	<b>2.75</b>	<b>3.01</b>	<b>3.27</b>	<b>3.53</b>
Struck capacity	m <sup>3</sup>	2.00	2.20	2.40	2.60	2.00	2.20	2.40	2.60
	yd <sup>3</sup>	<b>2.62</b>	<b>2.88</b>	<b>3.14</b>	<b>3.40</b>	<b>2.62</b>	<b>2.88</b>	<b>3.14</b>	<b>3.40</b>
Bucket width	mm	2550	2550	2750	2750	2550	2550	2750	2750
	ft/in	<b>8'4"</b>	<b>8'4"</b>	<b>9'0"</b>	<b>9'0"</b>	<b>8'4"</b>	<b>8'4"</b>	<b>9'0"</b>	<b>9'0"</b>
Dump clearance at full lift and 45° discharge	mm	2747	2698	2698	2650	2643	2593	2593	2544
	ft/in	<b>9'0"</b>	<b>8'10"</b>	<b>8'10"</b>	<b>8'8"</b>	<b>8'8"</b>	<b>8'6"</b>	<b>8'6"</b>	<b>8'4"</b>
Reach at full lift and 45° discharge	mm	1168	1205	1205	1243	1271	1307	1307	1344
	ft/in	<b>3'10"</b>	<b>3'11"</b>	<b>3'11"</b>	<b>4'1"</b>	<b>4'2"</b>	<b>4'3"</b>	<b>4'3"</b>	<b>4'5"</b>
Reach at 45° discharge and 2130 mm (7'0") clearance	mm	1639	1648	1648	1657	1681	1685	1685	1690
	ft/in	<b>5'5"</b>	<b>5'5"</b>	<b>5'5"</b>	<b>5'5"</b>	<b>5'6"</b>	<b>5'6"</b>	<b>5'6"</b>	<b>5'7"</b>
Reach with lift arms horizontal and bucket level	mm	2523	2586	2586	2648	2669	2732	2732	2794
	ft/in	<b>8'3"</b>	<b>8'6"</b>	<b>8'6"</b>	<b>8'8"</b>	<b>8'9"</b>	<b>9'0"</b>	<b>9'0"</b>	<b>9'2"</b>
Digging depth	mm	93	93	93	93	104	104	104	104
	in	<b>3.7</b>	<b>3.7</b>	<b>3.7</b>	<b>3.7</b>	<b>4.1</b>	<b>4.1</b>	<b>4.1</b>	<b>4.1</b>
Overall length	mm	7655	7718	7718	7780	7801	7864	7864	7926
	ft/in	<b>25'1"</b>	<b>25'4"</b>	<b>25'4"</b>	<b>25'6"</b>	<b>25'7"</b>	<b>25'10"</b>	<b>25'10"</b>	<b>26'0"</b>
Overall height with bucket at full raise	mm	5236	5294	5294	5353	5236	5294	5294	5353
	ft/in	<b>17'2"</b>	<b>17'4"</b>	<b>17'4"</b>	<b>17'7"</b>	<b>17'2"</b>	<b>17'4"</b>	<b>17'4"</b>	<b>17'7"</b>
Loader clearance radius with bucket in carry position	mm	5964	5984	6075	6095	6015	6036	6125	6146
	ft/in	<b>19'7"</b>	<b>19'8"</b>	<b>19'11"</b>	<b>20'0"</b>	<b>19'9"</b>	<b>19'10"</b>	<b>20'1"</b>	<b>20'2"</b>
Static tipping load straight	kg	9450	9367	9270	9174	9303	9218	9133	9035
	lb	<b>20,834</b>	<b>20,651</b>	<b>20,437</b>	<b>20,225</b>	<b>20,510</b>	<b>20,322</b>	<b>20,135</b>	<b>19,919</b>
Static tipping load with 40° turn	kg	8047	7971	7876	7787	7902	7825	7742	7651
	lb	<b>17,741</b>	<b>17,573</b>	<b>17,364</b>	<b>17,167</b>	<b>17,421</b>	<b>17,251</b>	<b>17,068</b>	<b>16,868</b>
Breakout force	kg	10 980	10 432	10 375	9873	10 859	10 311	10 264	9762
	lbf	<b>24,207</b>	<b>22,999</b>	<b>22,873</b>	<b>21,766</b>	<b>23,940</b>	<b>22,732</b>	<b>22,628</b>	<b>21,522</b>
Operating weight	kg	13 973	14 011	14 114	14 165	14 093	14 131	14 225	14 276
	lb	<b>30,805</b>	<b>30,889</b>	<b>31,116</b>	<b>31,228</b>	<b>31,070</b>	<b>31,153</b>	<b>31,361</b>	<b>31,473</b>

\*Meets Tier 4 Final/Stage IV/Japan 2014 (Tier 4 Final) emission standards.

**NOTE:** Specifications and ratings conform to all applicable standards recommended by the Society of Automotive Engineers (SAE), including SAE Standards J732 (APR07) which governs loader ratings.

# Wheel Loaders Integrated Toolcarriers

## Performance Data ● 930M\* Standard Lift ISO Bucket

Bucket Type		General Purpose			
Ground Engaging Type		Bolt-on Teeth			
Rated bucket capacity	m <sup>3</sup>	2.00	2.20	2.40	2.60
	yd <sup>3</sup>	<b>2.62</b>	<b>2.88</b>	<b>3.14</b>	<b>3.40</b>
Struck capacity	m <sup>3</sup>	1.90	2.10	2.30	2.50
	yd <sup>3</sup>	<b>2.49</b>	<b>2.75</b>	<b>3.01</b>	<b>3.27</b>
Bucket width	mm	2550	2550	2750	2750
	ft/in	<b>8'4"</b>	<b>8'4"</b>	<b>9'0"</b>	<b>9'0"</b>
Dump clearance at full lift and 45° discharge	mm	2643	2593	2593	2544
	ft/in	<b>8'8"</b>	<b>8'6"</b>	<b>8'6"</b>	<b>8'4"</b>
Reach at full lift and 45° discharge	mm	1271	1307	1307	1344
	ft/in	<b>4'2"</b>	<b>4'3"</b>	<b>4'3"</b>	<b>4'5"</b>
Reach at 45° discharge and 2130 mm (7'0") clearance	mm	1681	1685	1685	1690
	ft/in	<b>5'6"</b>	<b>5'6"</b>	<b>5'6"</b>	<b>5'7"</b>
Reach with lift arms horizontal and bucket level	mm	2669	2732	2732	2794
	ft/in	<b>8'9"</b>	<b>9'0"</b>	<b>9'0"</b>	<b>9'2"</b>
Digging depth	mm	104	104	104	104
	in	<b>4.1</b>	<b>4.1</b>	<b>4.1</b>	<b>4.1</b>
Overall length	mm	7781	7844	7844	7906
	ft/in	<b>25'6"</b>	<b>25'9"</b>	<b>25'9"</b>	<b>25'11"</b>
Overall height with bucket at full raise	mm	5236	5294	5294	5353
	ft/in	<b>17'2"</b>	<b>17'4"</b>	<b>17'4"</b>	<b>17'7"</b>
Loader clearance radius with bucket in carry position	mm	6015	6036	6125	6146
	ft/in	<b>19'9"</b>	<b>19'10"</b>	<b>20'1"</b>	<b>20'2"</b>
Static tipping load straight	kg	9404	9320	9235	9138
	lb	<b>20,732</b>	<b>20,547</b>	<b>20,360</b>	<b>20,146</b>
Static tipping load with 40° turn	kg	8001	7925	7842	7752
	lb	<b>17,639</b>	<b>17,472</b>	<b>17,289</b>	<b>17,090</b>
Breakout force	kg	11 553	10 944	10 894	10 340
	lbf	<b>25,470</b>	<b>24,128</b>	<b>24,017</b>	<b>22,796</b>
Operating weight	kg	14 011	14 049	14 142	14 194
	lb	<b>30,889</b>	<b>30,973</b>	<b>31,178</b>	<b>31,292</b>

\*Meets Tier 4 Final/Stage IV/Japan 2014 (Tier 4 Final) emission standards.

**NOTE:** Specifications and ratings conform to all applicable standards recommended by the Society of Automotive Engineers (SAE), including SAE Standards J732 (APR07) which governs loader ratings.

	Change in Operating Weight		Change in Articulated Static Tipping Load	
	kg	lb	kg	lb
Without Ride Control System .....	- 31	- 68	- 13	- 29
Without Guard, driveshaft .....	- 43	- 95	- 16	- 34
With Guard, windshield .....	41	90	23	50
Without Rooding Fenders .....	- 41	- 90	- 30	- 65
Without Secondary Steering .....	- 53	- 117	- 51	- 112
Without Guard, crankcase .....	- 11	- 24	- 15	- 32
Without Guard, power train .....	- 67	- 148	- 62	- 136
With Guard, power train side .....	11	24	9	21
Without Counterweight, Heavy .....	- 343	- 756	- 549	- 1209
With Counterweight, Logger .....	298	656	415	914
With Cold Start 120V .....	54	119	88	195
With Product Link .....	8	18	8	17
With Guard, rear wastegate .....	263	580	448	988
<b>Tires, 1-piece rims</b>				
17.5-25, Radial (L-2) VUT .....	- 437	- 963	- 507	- 1118
17.5-25, Radial (L-3) VMT .....	- 377	- 831	- 437	- 963
17.5-25, Radial (L-2) XTLA .....	- 569	- 1254	- 660	- 1455
17.5-25, Radial (L-3) XHA .....	- 481	- 1060	- 558	- 1230
<b>Tires, 3-piece rims</b>				
17.5-25, 16PR (L-2) .....	- 494	- 1089	- 573	- 1263
17.5-25, 16PR (L-3) .....	- 487	- 1074	- 565	- 1246
17.5-25, Radial (L-2) VUT .....	- 386	- 851	- 448	- 988
17.5-25, Radial (L-3) VMT .....	- 326	- 719	- 378	- 833
550/65 R25, Radial (L-3) .....	- 108	- 238	- 125	- 276
600/65 R25, Radial (L-3) .....	24	53	28	62
20.5-25, 16PR (L-3) .....	- 104	- 229	- 121	- 267
20.5 R25, Radial (L-5) XMINE D2 .....	616	1358	714	1574
20.5 R25, Radial (L-2) VUT .....	- 232	- 511	- 269	- 593
20.5 R25, Radial (L-3) VJT .....	32	71	37	82
20.5 R25, Radial (L-3) VMT .....	56	123	65	143

\*Meets Tier 4 Final/Stage IV/Japan 2014 (Tier 4 Final) emission standards.

# Wheel Loaders Integrated Toolcarriers

## Performance Data ● 930M\* High Lift ISO Bucket

Bucket Type	Ground Engaging Type	General Purpose							
		Bolt-on Cutting Edges				Bolt-on Teeth & Segments			
Rated bucket capacity	m <sup>3</sup>	2.10	2.30	2.50	2.70	2.10	2.30	2.50	2.70
	yd <sup>3</sup>	<b>2.75</b>	<b>3.01</b>	<b>3.27</b>	<b>3.53</b>	<b>2.75</b>	<b>3.01</b>	<b>3.27</b>	<b>3.53</b>
Struck capacity	m <sup>3</sup>	2.00	2.20	2.40	2.60	2.00	2.20	2.40	2.60
	yd <sup>3</sup>	<b>2.62</b>	<b>2.88</b>	<b>3.14</b>	<b>3.40</b>	<b>2.62</b>	<b>2.88</b>	<b>3.14</b>	<b>3.40</b>
Bucket width	mm	2550	2550	2750	2750	2550	2550	2750	2750
	ft/in	<b>8'4"</b>	<b>8'4"</b>	<b>9'0"</b>	<b>9'0"</b>	<b>8'4"</b>	<b>8'4"</b>	<b>9'0"</b>	<b>9'0"</b>
Dump clearance at full lift and 45° discharge	mm	3340	3291	3291	3243	3235	3185	3185	3137
	ft/in	<b>10'11"</b>	<b>10'10"</b>	<b>10'10"</b>	<b>10'8"</b>	<b>10'7"</b>	<b>10'5"</b>	<b>10'5"</b>	<b>10'4"</b>
Reach at full lift and 45° discharge	mm	1488	1525	1525	1563	1591	1627	1627	1664
	ft/in	<b>4'11"</b>	<b>5'0"</b>	<b>5'0"</b>	<b>5'2"</b>	<b>5'3"</b>	<b>5'4"</b>	<b>5'4"</b>	<b>5'6"</b>
Reach at 45° discharge and 2130 mm (7'0") clearance	mm	2364	2379	2379	2395	2420	2432	2432	2445
	ft/in	<b>7'9"</b>	<b>7'10"</b>	<b>7'10"</b>	<b>7'10"</b>	<b>7'11"</b>	<b>8'0"</b>	<b>8'0"</b>	<b>8'0"</b>
Reach with lift arms horizontal and bucket level	mm	3176	3239	3239	3301	3322	3385	3385	3447
	ft/in	<b>10'5"</b>	<b>10'8"</b>	<b>10'8"</b>	<b>10'10"</b>	<b>10'11"</b>	<b>11'1"</b>	<b>11'1"</b>	<b>11'4"</b>
Digging depth	mm	128	128	128	128	139	139	139	139
	in	<b>5.0</b>	<b>5.0</b>	<b>5.0</b>	<b>5.0</b>	<b>5.5</b>	<b>5.5</b>	<b>5.5</b>	<b>5.5</b>
Overall length	mm	8451	8514	8514	8576	8597	8660	8660	8722
	ft/in	<b>27'9"</b>	<b>27'11"</b>	<b>27'11"</b>	<b>28'2"</b>	<b>28'2"</b>	<b>28'5"</b>	<b>28'5"</b>	<b>28'7"</b>
Overall height with bucket at full raise	mm	5829	5887	5887	5946	5829	5887	5887	5946
	ft/in	<b>19'1"</b>	<b>19'4"</b>	<b>19'4"</b>	<b>19'6"</b>	<b>19'1"</b>	<b>19'4"</b>	<b>19'4"</b>	<b>19'6"</b>
Loader clearance radius with bucket in carry position	mm	6360	6383	6468	6490	6417	6441	6525	6547
	ft/in	<b>20'10"</b>	<b>20'11"</b>	<b>21'3"</b>	<b>21'3"</b>	<b>21'1"</b>	<b>21'2"</b>	<b>21'5"</b>	<b>21'6"</b>
Static tipping load straight	kg	6866	6802	6706	6628	6725	6661	6575	6497
	lb	<b>15,137</b>	<b>14,996</b>	<b>14,784</b>	<b>14,612</b>	<b>14,826</b>	<b>14,685</b>	<b>14,495</b>	<b>14,323</b>
Static tipping load with 40° turn	kg	5781	5722	5628	5555	5644	5583	5500	5426
	lb	<b>12,745</b>	<b>12,615</b>	<b>12,408</b>	<b>12,247</b>	<b>12,443</b>	<b>12,308</b>	<b>12,125</b>	<b>11,962</b>
Breakout force	kg	10 704	10 169	10 112	9622	10 583	10 048	10 001	9510
	lbf	<b>23,598</b>	<b>22,419</b>	<b>22,293</b>	<b>21,213</b>	<b>23,332</b>	<b>22,152</b>	<b>22,049</b>	<b>20,966</b>
Operating weight	kg	14 205	14 243	14 346	14 397	14 325	14 363	14 457	14 508
	lb	<b>31,317</b>	<b>31,400</b>	<b>31,627</b>	<b>31,740</b>	<b>31,581</b>	<b>31,665</b>	<b>31,872</b>	<b>31,985</b>

\*Meets Tier 4 Final/Stage IV/Japan 2014 (Tier 4 Final) emission standards.

**NOTE:** Specifications and ratings conform to all applicable standards recommended by the Society of Automotive Engineers (SAE), including SAE Standards J732 (APR07) which governs loader ratings.

Bucket Type		General Purpose			
Ground Engaging Type		Bolt-on Teeth			
Rated bucket capacity	m <sup>3</sup>	2.00	2.20	2.40	2.60
	yd <sup>3</sup>	<b>2.62</b>	<b>2.88</b>	<b>3.14</b>	<b>3.40</b>
Struck capacity	m <sup>3</sup>	1.90	2.10	2.30	2.50
	yd <sup>3</sup>	<b>2.49</b>	<b>2.75</b>	<b>3.01</b>	<b>3.27</b>
Bucket width	mm	2550	2550	2750	2750
	ft/in	<b>8'4"</b>	<b>8'4"</b>	<b>9'0"</b>	<b>9'0"</b>
Dump clearance at full lift and 45° discharge	mm	3235	3185	3185	3137
	ft/in	<b>10'7"</b>	<b>10'5"</b>	<b>10'5"</b>	<b>10'4"</b>
Reach at full lift and 45° discharge	mm	1591	1627	1627	1664
	ft/in	<b>5'3"</b>	<b>5'4"</b>	<b>5'4"</b>	<b>5'6"</b>
Reach at 45° discharge and 2130 mm (7'0") clearance	mm	2420	2432	2432	2445
	ft/in	<b>7'11"</b>	<b>8'0"</b>	<b>8'0"</b>	<b>8'0"</b>
Reach with lift arms horizontal and bucket level	mm	3322	3385	3385	3447
	ft/in	<b>10'11"</b>	<b>11'1"</b>	<b>11'1"</b>	<b>11'4"</b>
Digging depth	mm	139	139	139	139
	in	<b>5.5</b>	<b>5.5</b>	<b>5.5</b>	<b>5.5</b>
Overall length	mm	8582	8645	8645	8707
	ft/in	<b>28'2"</b>	<b>28'4"</b>	<b>28'4"</b>	<b>28'7"</b>
Overall height with bucket at full raise	mm	5829	5887	5887	5946
	ft/in	<b>19'1"</b>	<b>19'4"</b>	<b>19'4"</b>	<b>19'6"</b>
Loader clearance radius with bucket in carry position	mm	6417	6441	6525	6547
	ft/in	<b>21'1"</b>	<b>21'2"</b>	<b>21'5"</b>	<b>21'6"</b>
Static tipping load straight	kg	6821	6757	6672	6594
	lb	<b>15,038</b>	<b>14,897</b>	<b>14,709</b>	<b>14,537</b>
Static tipping load with 40° turn	kg	5738	5678	5595	5522
	lb	<b>12,650</b>	<b>12,518</b>	<b>12,335</b>	<b>12,174</b>
Breakout force	kg	11 263	10 669	10 619	10 077
	lbf	<b>24,831</b>	<b>23,521</b>	<b>23,411</b>	<b>22,216</b>
Operating weight	kg	14 243	14 281	14 374	14 426
	lb	<b>31,400</b>	<b>31,484</b>	<b>31,689</b>	<b>31,804</b>

\*Meets Tier 4 Final/Stage IV/Japan 2014 (Tier 4 Final) emission standards.

**NOTE:** Specifications and ratings conform to all applicable standards recommended by the Society of Automotive Engineers (SAE), including SAE Standards J732 (APR07) which governs loader ratings.



	Change in Operating Weight		Change in Articulated Static Tipping Load	
	kg	lb	kg	lb
Without Ride Control System .....	- 31	- 68	- 10	- 23
Without Guard, driveshaft .....	- 43	- 95	- 12	- 27
With Guard, windshield .....	41	90	18	39
Without Rooding Fenders .....	- 41	- 90	- 23	- 51
Without Secondary Steering .....	- 53	- 117	- 40	- 88
Without Guard, crankcase .....	- 11	- 24	- 11	- 25
Without Guard, power train .....	- 67	- 148	- 48	- 106
With Guard, power train side .....	11	24	7	16
Without Counterweight, Heavy .....	- 343	- 756	- 427	- 942
With Cold Start 120V .....	54	119	69	152
With Product Link .....	8	18	6	13
With Guard, rear wastegate .....	263	580	349	769
<b>Tires, 1-piece rims</b>				
17.5-25, Radial (L-2) VUT .....	- 437	- 963	- 395	- 871
17.5-25, Radial (L-3) VMT .....	- 377	- 831	- 341	- 752
17.5-25, Radial (L-2) XTLA .....	- 569	- 1254	- 514	- 1133
17.5-25, Radial (L-3) XHA .....	- 481	- 1060	- 434	- 957
<b>Tires, 3-piece rims</b>				
17.5-25, 16PR (L-2) .....	- 494	- 1089	- 446	- 983
17.5-25, 16PR (L-3) .....	- 487	- 1074	- 440	- 970
17.5-25, Radial (L-2) VUT .....	- 386	- 851	- 349	- 769
17.5-25, Radial (L-3) VMT .....	- 326	- 719	- 295	- 650
550/65 R25, Radial (L-3) .....	- 108	- 238	- 97	- 214
600/65 R25, Radial (L-3) .....	24	53	22	49
20.5-25, 16PR (L-3) .....	- 104	- 229	- 94	- 207
20.5 R25, Radial (L-5) XMINE D2 .....	616	1358	556	1226
20.5 R25, Radial (L-2) VUT .....	- 232	- 511	- 209	- 461
20.5 R25, Radial (L-3) VJT .....	32	71	29	64
20.5 R25, Radial (L-3) VMT .....	56	123	51	112

\*Meets Tier 4 Final/Stage IV/Japan 2014 (Tier 4 Final) emission standards.

- Performance Data
- 930M\* Standard Lift
  - Pallet Forks ● Construction Forks

## Wheel Loaders Integrated Toolcarriers

		Pallet Forks – Fusion		
Fork tine length	mm	1220	1370	1524
	ft/in	4'0"	4'6"	5'0"
Ground to top of tine clearance	mm	3693	3693	3693
	ft/in	12'1"	12'1"	12'1"
Reach with lift arms horizontal and forks level	mm	1569	1569	1569
	ft/in	5'2"	5'2"	5'2"
Overall length	mm	7882	8032	8186
	ft/in	25'10"	26'4"	26'10"
Static tipping load with level arms and forks, straight	kg	7689	7473	7262
	lb	16,951	16,475	16,010
Static tipping load with level arms and forks, full 40° turn	kg	6577	6389	6205
	lb	14,500	14,085	13,680
Operating weight	kg	13 671	13 693	13 714
	lb	30,139	30,188	30,234

		Pallet Forks – ISO		
Fork tine length	mm	1220	1370	1524
	ft/in	4'0"	4'6"	5'0"
Ground to top of tine clearance	mm	3693	3693	3693
	ft/in	12'1"	12'1"	12'1"
Reach with lift arms horizontal and forks level	mm	1595	1595	1595
	ft/in	5'3"	5'3"	5'3"
Overall length	mm	7913	8063	8217
	ft/in	26'0"	26'5"	27'0"
Static tipping load with level arms and forks, straight	kg	7596	7386	7180
	lb	16,746	16,283	15,829
Static tipping load with level arms and forks, full 40° turn	kg	6503	6321	6141
	lb	14,337	13,935	13,539
Operating weight	kg	13 541	13 562	13 584
	lb	29,853	29,899	29,948

		Construction Forks – Fusion	
Fork tine length	mm	1524	1829
	ft/in	5'0"	6'0"
Ground to top of tine clearance	mm	3630	3630
	ft/in	11'11"	11'11"
Reach with lift arms horizontal and forks level	mm	1627	1627
	ft/in	5'4"	5'4"
Overall length	mm	8305	8610
	ft/in	27'3"	28'3"
Static tipping load with level arms and forks, straight	kg	6919	6550
	lb	15,254	14,440
Static tipping load with level arms and forks, full 40° turn	kg	5887	5566
	lb	12,979	12,271
Operating weight	kg	14 006	14 050
	lb	30,878	30,975

\*Meets Tier 4 Final/Stage IV/Japan 2014 (Tier 4 Final) emission standards.

NOTE: Dimensions listed are for a machine configured with attachment, counterweights, additional guarding, 80 kg (176 lb) operator, and Michelin 20.5 R25 (L-3) XHA2 tires.

# Wheel Loaders Integrated Toolcarriers

- ## Performance Data
- 930M\* Standard Lift
  - Material Handling Arm

Handling Arm Position		Material Handling Arm – Fusion		
		Retracted	Mid-position	Extended
Operating load	kg	2183	1851	1607
	lb	<b>4812</b>	<b>4081</b>	<b>3543</b>
Static tipping load, straight	kg	4994	4236	3677
	lb	<b>11,010</b>	<b>9339</b>	<b>8106</b>
Static tipping load, full 40° turn	kg	4365	3702	3214
	lb	<b>9623</b>	<b>8162</b>	<b>7086</b>
Operating weight	kg	13 538	13 538	13 538
	lb	<b>29,846</b>	<b>29,846</b>	<b>29,846</b>

\*Meets Tier 4 Final/Stage IV/Japan 2014 (Tier 4 Final) emission standards.

**NOTE:** Dimensions listed are for a machine configured with attachment, counterweights, additional guarding, 80 kg (**176 lb**) operator, and Michelin 20.5 R25 (L-3) XHA2 tires.

Performance Data  
 ● 930M\* High Lift  
 ● Pallet Forks ● Construction Forks

Wheel Loaders  
 Integrated Toolcarriers

		Pallet Forks – Fusion		
Fork tine length	mm	1220	1370	1524
	ft/in	4'0"	4'6"	5'0"
Ground to top of tine clearance	mm	4286	4286	4286
	ft/in	14'1"	14'1"	14'1"
Reach with lift arms horizontal and forks level	mm	2222	2222	2222
	ft/in	7'3"	7'3"	7'3"
Overall length	mm	8689	8839	8993
	ft/in	28'6"	29'0"	29'6"
Static tipping load with level arms and forks, straight	kg	5916	5772	5629
	lb	13,043	12,725	12,410
Static tipping load with level arms and forks, full 40° turn	kg	5015	4889	4765
	lb	11,056	10,778	10,505
Operating weight	kg	13 904	13 925	13 946
	lb	30,653	30,699	30,746

		Pallet Forks – ISO		
Fork tine length	mm	1220	1370	1524
	ft/in	4'0"	4'6"	5'0"
Ground to top of tine clearance	mm	4286	4286	4286
	ft/in	14'1"	14'1"	14'1"
Reach with lift arms horizontal and forks level	mm	2248	2248	2248
	ft/in	7'5"	7'5"	7'5"
Overall length	mm	8718	8868	9022
	ft/in	28'7"	29'1"	29'7"
Static tipping load with level arms and forks, straight	kg	5890	5748	5607
	lb	12,985	12,672	12,361
Static tipping load with level arms and forks, full 40° turn	kg	5001	4877	4755
	lb	11,025	10,752	10,483
Operating weight	kg	13 773	13 794	13 816
	lb	30,364	30,411	30,459

		Construction Forks – Fusion	
Fork tine length	mm	1524	1829
	ft/in	5'0"	6'0"
Ground to top of tine clearance	mm	4223	4223
	ft/in	13'10"	13'10"
Reach with lift arms horizontal and forks level	mm	2280	2280
	ft/in	7'6"	7'6"
Overall length	mm	9094	9399
	ft/in	29'10"	30'10"
Static tipping load with level arms and forks, straight	kg	5322	5069
	lb	11,733	11,175
Static tipping load with level arms and forks, full 40° turn	kg	4476	4256
	lb	9868	9383
Operating weight	kg	14 238	14 283
	lb	31,389	31,489

\*Meets Tier 4 Final/Stage IV/Japan 2014 (Tier 4 Final) emission standards.

NOTE: Dimensions listed are for a machine configured with attachment, counterweights, additional guarding, 80 kg (176 lb) operator, and Michelin 20.5 R25 (L-3) XHA2 tires.

# Wheel Loaders Integrated Toolcarriers

- Performance Data
- 930M\* High Lift
  - Material Handling Arm

Handling Arm Position		Material Handling Arm – Fusion		
		Retracted	Mid-position	Extended
Operating load	kg	1785	1544	1360
	lb	<b>3935</b>	<b>3404</b>	<b>2998</b>
Static tipping load, straight	kg	4119	3563	3139
	lb	<b>9081</b>	<b>7855</b>	<b>6920</b>
Static tipping load, full 40° turn	kg	3570	3088	2720
	lb	<b>7870</b>	<b>6808</b>	<b>5997</b>
Operating weight	kg	13 771	13 771	13 771
	lb	<b>30,360</b>	<b>30,360</b>	<b>30,360</b>

\*Meets Tier 4 Final/Stage IV/Japan 2014 (Tier 4 Final) emission standards.

**NOTE:** Dimensions listed are for a machine configured with attachment, counterweights, additional guarding, 80 kg (**176 lb**) operator, and Michelin 20.5 R25 (L-3) XHA2 tires.

Bucket Type		General Purpose								
		Bolt-on Cutting Edges			Bolt-on Teeth & Segments			Bolt-on Teeth		
<b>Ground Engaging Type</b>										
Rated bucket capacity	m <sup>3</sup>	2.50	2.70	2.90	2.50	2.70	2.90	2.40	2.60	2.80
	yd <sup>3</sup>	<b>3.27</b>	<b>3.53</b>	<b>3.79</b>	<b>3.27</b>	<b>3.53</b>	<b>3.79</b>	<b>3.14</b>	<b>3.40</b>	<b>3.66</b>
Struck capacity	m <sup>3</sup>	2.30	2.50	2.70	2.30	2.50	2.70	2.20	2.40	2.60
	yd <sup>3</sup>	<b>3.01</b>	<b>3.27</b>	<b>3.53</b>	<b>3.01</b>	<b>3.27</b>	<b>3.53</b>	<b>2.88</b>	<b>3.14</b>	<b>3.40</b>
Bucket width	mm	2750	2750	2750	2750	2750	2750	2750	2750	2750
	ft/in	<b>9'0"</b>	<b>9'0"</b>	<b>9'0"</b>	<b>9'0"</b>	<b>9'0"</b>	<b>9'0"</b>	<b>9'0"</b>	<b>9'0"</b>	<b>9'0"</b>
Dump clearance at full lift and 45° discharge	mm	2869	2822	2786	2764	2716	2680	2764	2716	2680
	ft/in	<b>9'5"</b>	<b>9'3"</b>	<b>9'2"</b>	<b>9'1"</b>	<b>8'11"</b>	<b>8'10"</b>	<b>9'1"</b>	<b>8'11"</b>	<b>8'10"</b>
Reach at full lift and 45° discharge	mm	1108	1146	1178	1210	1247	1278	1210	1247	1278
	ft/in	<b>3'8"</b>	<b>3'9"</b>	<b>3'10"</b>	<b>4'0"</b>	<b>4'1"</b>	<b>4'2"</b>	<b>4'0"</b>	<b>4'1"</b>	<b>4'2"</b>
Reach at 45° discharge and 2130 mm (7'0") clearance	mm	1637	1652	1664	1684	1696	1705	1684	1696	1705
	ft/in	<b>5'4"</b>	<b>5'5"</b>	<b>5'6"</b>	<b>5'6"</b>	<b>5'7"</b>	<b>5'7"</b>	<b>5'6"</b>	<b>5'7"</b>	<b>5'7"</b>
Reach with lift arms horizontal and bucket level	mm	2452	2514	2563	2598	2660	2709	2598	2660	2709
	ft/in	<b>8'1"</b>	<b>8'3"</b>	<b>8'5"</b>	<b>8'6"</b>	<b>8'9"</b>	<b>8'11"</b>	<b>8'6"</b>	<b>8'9"</b>	<b>8'11"</b>
Digging depth	mm	100	100	100	112	112	112	112	112	112
	in	<b>3.9</b>	<b>3.9</b>	<b>3.9</b>	<b>4.4</b>	<b>4.4</b>	<b>4.4</b>	<b>4.4</b>	<b>4.4</b>	<b>4.4</b>
Overall length	mm	7604	7666	7715	7750	7812	7861	7729	7791	7840
	ft/in	<b>24'11"</b>	<b>25'2"</b>	<b>25'4"</b>	<b>25'5"</b>	<b>25'8"</b>	<b>25'9"</b>	<b>25'4"</b>	<b>25'7"</b>	<b>25'9"</b>
Overall height with bucket at full raise	mm	5242	5301	5348	5242	5301	5348	5242	5301	5348
	ft/in	<b>17'2"</b>	<b>17'5"</b>	<b>17'7"</b>	<b>17'2"</b>	<b>17'5"</b>	<b>17'7"</b>	<b>17'2"</b>	<b>17'5"</b>	<b>17'7"</b>
Loader clearance radius with bucket in carry position	mm	6117	6136	6150	6164	6183	6198	6164	6183	6198
	ft/in	<b>20'1"</b>	<b>20'2"</b>	<b>20'2"</b>	<b>20'3"</b>	<b>20'3"</b>	<b>20'4"</b>	<b>20'3"</b>	<b>20'3"</b>	<b>20'4"</b>
Static tipping load straight	kg	12 344	12 245	12 161	12 206	12 105	12 020	12 309	12 209	12 125
	lb	<b>27,214</b>	<b>26,996</b>	<b>26,810</b>	<b>26,910</b>	<b>26,687</b>	<b>26,500</b>	<b>27,137</b>	<b>26,916</b>	<b>26,731</b>
Static tipping load with 40° turn	kg	10 517	10 426	10 350	10 382	10 289	10 212	10 482	10 391	10 314
	lb	<b>23,186</b>	<b>22,985</b>	<b>22,818</b>	<b>22,888</b>	<b>22,683</b>	<b>22,514</b>	<b>23,109</b>	<b>22,908</b>	<b>22,738</b>
Breakout force	kg	13 813	13 082	12 552	13 701	12 971	12 441	14 640	13 821	13 229
	lbf	<b>30,453</b>	<b>28,841</b>	<b>27,673</b>	<b>30,206</b>	<b>28,596</b>	<b>27,428</b>	<b>32,276</b>	<b>30,470</b>	<b>29,165</b>
Operating weight	kg	16 001	16 046	16 082	16 112	16 157	16 193	16 030	16 074	16 111
	lb	<b>35,276</b>	<b>35,375</b>	<b>35,455</b>	<b>35,521</b>	<b>35,620</b>	<b>35,699</b>	<b>35,340</b>	<b>35,437</b>	<b>35,519</b>

\*Meets Tier 4 Final/Stage IV/Japan 2014 (Tier 4 Final) emission standards.

**NOTE:** Specifications and ratings conform to all applicable standards recommended by the Society of Automotive Engineers (SAE), including SAE Standards J732 (APR07) which governs loader ratings.

# Wheel Loaders Integrated Toolcarriers

## Performance Data ● 938M\* Standard Lift Pin On Bucket

Bucket Type	Ground Engaging Type	Light Material								
		Bolt-on Cutting Edges			Bolt-on Teeth & Segments			Bolt-on Teeth		
Rated bucket capacity	m <sup>3</sup>	3.50	4.20	5.00	3.50	4.20	5.00	3.40	4.10	4.90
	yd <sup>3</sup>	<b>4.58</b>	<b>5.49</b>	<b>6.54</b>	<b>4.58</b>	<b>5.49</b>	<b>6.54</b>	<b>4.45</b>	<b>5.36</b>	<b>6.41</b>
Struck capacity	m <sup>3</sup>	3.30	4.00	4.80	3.30	4.00	4.80	3.20	3.90	4.70
	yd <sup>3</sup>	<b>4.32</b>	<b>5.23</b>	<b>6.28</b>	<b>4.32</b>	<b>5.23</b>	<b>6.28</b>	<b>4.19</b>	<b>5.10</b>	<b>6.15</b>
Bucket width	mm	2750	2750	2750	2750	2750	2750	2750	2750	2750
	ft/in	<b>9'0"</b>	<b>9'0"</b>	<b>9'0"</b>	<b>9'0"</b>	<b>9'0"</b>	<b>9'0"</b>	<b>9'0"</b>	<b>9'0"</b>	<b>9'0"</b>
Dump clearance at full lift and 45° discharge	mm	2691	2571	2571	2580	2460	2460	2580	2460	2460
	ft/in	<b>8'10"</b>	<b>8'5"</b>	<b>8'5"</b>	<b>8'6"</b>	<b>8'1"</b>	<b>8'1"</b>	<b>8'6"</b>	<b>8'1"</b>	<b>8'1"</b>
Reach at full lift and 45° discharge	mm	1174	1294	1294	1269	1389	1389	1269	1389	1389
	ft/in	<b>3'10"</b>	<b>4'3"</b>	<b>4'3"</b>	<b>4'2"</b>	<b>4'7"</b>	<b>4'7"</b>	<b>4'2"</b>	<b>4'7"</b>	<b>4'7"</b>
Reach at 45° discharge and 2130 mm (7'0") clearance	mm	1608	1654	1654	1634	1672	1672	1634	1672	1672
	ft/in	<b>5'3"</b>	<b>5'5"</b>	<b>5'5"</b>	<b>5'4"</b>	<b>5'6"</b>	<b>5'6"</b>	<b>5'4"</b>	<b>5'6"</b>	<b>5'6"</b>
Reach with lift arms horizontal and bucket level	mm	2642	2812	2812	2788	2958	2958	2788	2958	2958
	ft/in	<b>8'8"</b>	<b>9'3"</b>	<b>9'3"</b>	<b>9'2"</b>	<b>9'8"</b>	<b>9'8"</b>	<b>9'2"</b>	<b>9'8"</b>	<b>9'8"</b>
Digging depth	mm	100	100	100	112	112	112	112	112	112
	in	<b>3.9</b>	<b>3.9</b>	<b>3.9</b>	<b>4.4</b>	<b>4.4</b>	<b>4.4</b>	<b>4.4</b>	<b>4.4</b>	<b>4.4</b>
Overall length	mm	7794	7964	7964	7940	8110	8110	7919	8089	8089
	ft/in	<b>25'7"</b>	<b>26'2"</b>	<b>26'2"</b>	<b>26'1"</b>	<b>26'7"</b>	<b>26'7"</b>	<b>26'0"</b>	<b>26'6"</b>	<b>26'6"</b>
Overall height with bucket at full raise	mm	5346	5507	5786	5346	5507	5786	5346	5507	5786
	ft/in	<b>17'6"</b>	<b>18'1"</b>	<b>19'0"</b>	<b>17'6"</b>	<b>18'1"</b>	<b>19'0"</b>	<b>17'6"</b>	<b>18'1"</b>	<b>19'0"</b>
Loader clearance radius with bucket in carry position	mm	6174	6227	6227	6223	6277	6277	6223	6277	6277
	ft/in	<b>20'3"</b>	<b>20'5"</b>	<b>20'5"</b>	<b>20'5"</b>	<b>20'7"</b>	<b>20'7"</b>	<b>20'5"</b>	<b>20'7"</b>	<b>20'7"</b>
Static tipping load straight	kg	11 960	11 637	11 636	11 818	11 491	11 491	11 923	11 599	11 599
	lb	<b>26,367</b>	<b>25,655</b>	<b>25,653</b>	<b>26,054</b>	<b>25,333</b>	<b>25,333</b>	<b>26,286</b>	<b>25,571</b>	<b>25,571</b>
Static tipping load with 40° turn	kg	10 164	9870	9866	10 025	9727	9723	10 128	9833	9829
	lb	<b>22,408</b>	<b>21,760</b>	<b>21,751</b>	<b>22,101</b>	<b>21,444</b>	<b>21,436</b>	<b>22,328</b>	<b>21,678</b>	<b>21,669</b>
Breakout force	kg	11 750	10 331	10 281	11 639	10 219	10 170	12 340	10 780	10 728
	lbf	<b>25,904</b>	<b>22,776</b>	<b>22,666</b>	<b>25,660</b>	<b>22,529</b>	<b>22,421</b>	<b>27,205</b>	<b>23,766</b>	<b>23,651</b>
Operating weight	kg	16 028	16 347	16 394	16 319	16 458	16 505	16 236	16 376	16 423
	lb	<b>35,336</b>	<b>36,039</b>	<b>36,143</b>	<b>35,977</b>	<b>36,284</b>	<b>36,387</b>	<b>35,794</b>	<b>36,103</b>	<b>36,206</b>

\*Meets Tier 4 Final/Stage IV/Japan 2014 (Tier 4 Final) emission standards.

**NOTE:** Specifications and ratings conform to all applicable standards recommended by the Society of Automotive Engineers (SAE), including SAE Standards J732 (APR07) which governs loader ratings.

	Change in Operating Weight		Change in Articulated Static Tipping Load	
	kg	lb	kg	lb
Without Ride Control System	- 31	- 68	- 14	- 31
Without Guard, driveshaft	- 44	- 97	- 13	- 29
With Guard, windshield	34	75	20	44
Without Rounding Fenders	- 41	- 90	- 31	- 68
Without Secondary Steering	- 53	- 117	- 53	- 117
Without Guard, crankcase	- 11	- 24	- 15	- 34
Without Guard, power train	- 67	- 148	- 64	- 142
With Guard, power train side	11	24	10	22
Without Counterweight, Heavy	- 343	- 756	- 570	- 1256
With Counterweight, Logger	299	658	402	886
With Cold Start 120V	54	119	92	202
With Product Link	8	18	8	18
With Guard, rear wastegate	276	608	516	1137
<b>Tires, 3-piece rims</b>				
20.5-25, 16PR (L-3)	- 104	- 229	- 126	- 278
20.5-25, 16PR (L-5)	224	494	272	600
550/65 R25, Radial (L-3)	- 108	- 238	- 131	- 289
600/65 R25, Radial (L-3)	24	53	29	64
20.5 R25, Radial (L-5) XMINE D2	<b>616</b>	<b>1358</b>	<b>749</b>	<b>1651</b>
20.5 R25, Radial (L-2) VUT	- 188	- 414	- 228	- 503
20.5 R25, Radial (L-3) VJT	32	71	39	86
20.5 R25, Radial (L-3) VMT	44	97	53	117
20.5 R25, Radial (L-5) VSDL	792	1746	962	2121

Bucket Type	General Purpose									
		Bolt-on Cutting Edges			Bolt-on Teeth & Segments			Bolt-on Teeth		
Ground Engaging Type										
Rated bucket capacity	m <sup>3</sup>	2.50	2.70	2.90	2.50	2.70	2.90	2.40	2.60	2.80
	yd <sup>3</sup>	<b>3.27</b>	<b>3.53</b>	<b>3.79</b>	<b>3.27</b>	<b>3.53</b>	<b>3.79</b>	<b>3.14</b>	<b>3.40</b>	<b>3.66</b>
Struck capacity	m <sup>3</sup>	2.30	2.50	2.70	2.30	2.50	2.70	2.20	2.40	2.60
	yd <sup>3</sup>	<b>3.01</b>	<b>3.27</b>	<b>3.53</b>	<b>3.01</b>	<b>3.27</b>	<b>3.53</b>	<b>2.88</b>	<b>3.14</b>	<b>3.40</b>
Bucket width	mm	2750	2750	2750	2750	2750	2750	2750	2750	2750
	ft/in	<b>9'0"</b>	<b>9'0"</b>	<b>9'0"</b>	<b>9'0"</b>	<b>9'0"</b>	<b>9'0"</b>	<b>9'0"</b>	<b>9'0"</b>	<b>9'0"</b>
Dump clearance at full lift and 45° discharge	mm	3450	3403	3367	3344	3297	3260	3344	3297	3260
	ft/in	<b>11'4"</b>	<b>11'2"</b>	<b>11'1"</b>	<b>11'0"</b>	<b>10'10"</b>	<b>10'8"</b>	<b>11'0"</b>	<b>10'10"</b>	<b>10'8"</b>
Reach at full lift and 45° discharge	mm	1374	1413	1444	1476	1514	1545	1476	1514	1545
	ft/in	<b>4'6"</b>	<b>4'8"</b>	<b>4'9"</b>	<b>4'10"</b>	<b>5'0"</b>	<b>5'1"</b>	<b>4'10"</b>	<b>5'0"</b>	<b>5'1"</b>
Reach at 45° discharge and 2130 mm (7'0") clearance	mm	2298	2319	2335	2357	2375	2389	2357	2375	2389
	ft/in	<b>7'6"</b>	<b>7'7"</b>	<b>7'8"</b>	<b>7'9"</b>	<b>7'10"</b>	<b>7'10"</b>	<b>7'9"</b>	<b>7'10"</b>	<b>7'10"</b>
Reach with lift arms horizontal and bucket level	mm	3059	3121	3170	3205	3267	3316	3205	3267	3316
	ft/in	<b>10'0"</b>	<b>10'3"</b>	<b>10'5"</b>	<b>10'6"</b>	<b>10'9"</b>	<b>10'11"</b>	<b>10'6"</b>	<b>10'9"</b>	<b>10'11"</b>
Digging depth	mm	135	135	135	146	146	146	146	146	146
	in	<b>5.3</b>	<b>5.3</b>	<b>5.3</b>	<b>5.7</b>	<b>5.7</b>	<b>5.7</b>	<b>5.7</b>	<b>5.7</b>	<b>5.7</b>
Overall length	mm	8344	8406	8455	8490	8552	8601	8475	8537	8586
	ft/in	<b>27'5"</b>	<b>27'7"</b>	<b>27'9"</b>	<b>27'10"</b>	<b>28'1"</b>	<b>28'3"</b>	<b>27'10"</b>	<b>28'0"</b>	<b>28'2"</b>
Overall height with bucket at full raise	mm	5823	5881	5929	5823	5881	5929	5823	5881	5929
	ft/in	<b>19'1"</b>	<b>19'4"</b>	<b>19'5"</b>	<b>19'1"</b>	<b>19'4"</b>	<b>19'5"</b>	<b>19'1"</b>	<b>19'4"</b>	<b>19'5"</b>
Loader clearance radius with bucket in carry position	mm	6472	6493	6509	6525	6546	6563	6525	6546	6563
	ft/in	<b>21'3"</b>	<b>21'4"</b>	<b>21'4"</b>	<b>21'5"</b>	<b>21'6"</b>	<b>21'6"</b>	<b>21'5"</b>	<b>21'6"</b>	<b>21'6"</b>
Static tipping load straight	kg	8714	8637	8574	8582	8505	8440	8680	8603	8540
	lb	<b>19,211</b>	<b>19,041</b>	<b>18,902</b>	<b>18,920</b>	<b>18,750</b>	<b>18,607</b>	<b>19,136</b>	<b>18,966</b>	<b>18,827</b>
Static tipping load with 40° turn	kg	7372	7301	7242	7243	7171	7111	7338	7267	7208
	lb	<b>16,252</b>	<b>16,096</b>	<b>15,966</b>	<b>15,968</b>	<b>15,809</b>	<b>15,677</b>	<b>16,178</b>	<b>16,021</b>	<b>15,891</b>
Breakout force	kg	13 284	12 580	12 069	13 173	12 468	11 957	14 075	13 285	12 714
	lbf	<b>29,286</b>	<b>27,734</b>	<b>26,608</b>	<b>29,042</b>	<b>27,487</b>	<b>26,361</b>	<b>31,030</b>	<b>29,289</b>	<b>28,030</b>
Operating weight	kg	15 899	15 944	15 981	16 010	16 055	16 091	15 928	15 973	16 009
	lb	<b>35,051</b>	<b>35,150</b>	<b>35,232</b>	<b>35,296</b>	<b>35,395</b>	<b>35,475</b>	<b>35,115</b>	<b>35,214</b>	<b>35,294</b>

\*Meets Tier 4 Final/Stage IV/Japan 2014 (Tier 4 Final) emission standards.

NOTE: Specifications and ratings conform to all applicable standards recommended by the Society of Automotive Engineers (SAE), including SAE Standards J732 (APR07) which governs loader ratings.



# Wheel Loaders Integrated Toolcarriers

## Performance Data ● 938M\* High Lift Pin On Bucket

Bucket Type	Light Material									
	Ground Engaging Type	Bolt-on Cutting Edges			Bolt-on Teeth & Segments			Bolt-on Teeth		
Rated bucket capacity		m <sup>3</sup>	3.50	4.20	5.00	3.50	4.20	5.00	3.40	4.10
	yd <sup>3</sup>	<b>4.58</b>	<b>5.49</b>	<b>6.54</b>	<b>4.58</b>	<b>5.49</b>	<b>6.54</b>	<b>4.45</b>	<b>5.36</b>	<b>6.41</b>
Struck capacity	m <sup>3</sup>	3.30	4.00	4.80	3.30	4.00	4.80	3.20	3.90	4.70
	yd <sup>3</sup>	<b>4.32</b>	<b>5.23</b>	<b>6.28</b>	<b>4.32</b>	<b>5.23</b>	<b>6.28</b>	<b>4.19</b>	<b>5.10</b>	<b>6.15</b>
Bucket width	mm	2750	2750	2750	2750	2750	2750	2750	2750	2750
	ft/in	<b>9'0"</b>	<b>9'0"</b>	<b>9'0"</b>	<b>9'0"</b>	<b>9'0"</b>	<b>9'0"</b>	<b>9'0"</b>	<b>9'0"</b>	<b>9'0"</b>
Dump clearance at full lift and 45° discharge	mm	3272	3152	3152	3161	3040	3040	3161	3040	3040
	ft/in	<b>10'9"</b>	<b>10'4"</b>	<b>10'4"</b>	<b>10'4"</b>	<b>10'0"</b>	<b>10'0"</b>	<b>10'4"</b>	<b>10'0"</b>	<b>10'0"</b>
Reach at full lift and 45° discharge	mm	1440	1561	1561	1536	1656	1656	1536	1656	1656
	ft/in	<b>4'9"</b>	<b>5'1"</b>	<b>5'1"</b>	<b>5'0"</b>	<b>5'5"</b>	<b>5'5"</b>	<b>5'0"</b>	<b>5'5"</b>	<b>5'5"</b>
Reach at 45° discharge and 2130 mm (7'0") clearance	mm	2290	2353	2353	2332	2390	2390	2332	2390	2390
	ft/in	<b>7'6"</b>	<b>7'9"</b>	<b>7'9"</b>	<b>7'8"</b>	<b>7'10"</b>	<b>7'10"</b>	<b>7'8"</b>	<b>7'10"</b>	<b>7'10"</b>
Reach with lift arms horizontal and bucket level	mm	3249	3419	3419	3395	3565	3565	3395	3565	3565
	ft/in	<b>10'8"</b>	<b>11'3"</b>	<b>11'3"</b>	<b>11'2"</b>	<b>11'8"</b>	<b>11'8"</b>	<b>11'2"</b>	<b>11'8"</b>	<b>11'8"</b>
Digging depth	mm	135	135	135	146	146	146	146	146	146
	in	<b>5.3</b>	<b>5.3</b>	<b>5.3</b>	<b>5.7</b>	<b>5.7</b>	<b>5.7</b>	<b>5.7</b>	<b>5.7</b>	<b>5.7</b>
Overall length	mm	8534	8704	8704	8680	8850	8850	8665	8835	8835
	ft/in	<b>28'0"</b>	<b>28'7"</b>	<b>28'7"</b>	<b>28'6"</b>	<b>29'0"</b>	<b>29'0"</b>	<b>28'5"</b>	<b>29'0"</b>	<b>29'0"</b>
Overall height with bucket at full raise	mm	5926	6087	6367	5926	6087	6367	5926	6087	6367
	ft/in	<b>19'5"</b>	<b>20'0"</b>	<b>20'11"</b>	<b>19'5"</b>	<b>20'0"</b>	<b>20'11"</b>	<b>19'5"</b>	<b>20'0"</b>	<b>20'11"</b>
Loader clearance radius with bucket in carry position	mm	6536	6594	6594	6590	6649	6649	6590	6649	6649
	ft/in	<b>21'5"</b>	<b>21'8"</b>	<b>21'8"</b>	<b>21'7"</b>	<b>21'10"</b>	<b>21'10"</b>	<b>21'7"</b>	<b>21'10"</b>	<b>21'10"</b>
Static tipping load straight	kg	8409	8165	8148	8275	8028	8010	8375	8129	8118
	lb	<b>18,539</b>	<b>18,001</b>	<b>17,963</b>	<b>18,243</b>	<b>17,699</b>	<b>17,659</b>	<b>18,464</b>	<b>17,921</b>	<b>17,897</b>
Static tipping load with 40° turn	kg	7087	6861	6842	6955	6726	6708	7053	6826	6808
	lb	<b>15,624</b>	<b>15,126</b>	<b>15,084</b>	<b>15,333</b>	<b>14,828</b>	<b>14,789</b>	<b>15,549</b>	<b>15,049</b>	<b>15,009</b>
Breakout force	kg	11 295	9925	9875	11 183	9814	9764	11 857	10 352	10 300
	lbf	<b>24,901</b>	<b>21,881</b>	<b>21,771</b>	<b>24,654</b>	<b>21,636</b>	<b>21,526</b>	<b>26,140</b>	<b>22,822</b>	<b>22,708</b>
Operating weight	kg	16 106	16 245	16 292	16 217	16 356	16 043	16 134	16 274	16 321
	lb	<b>35,508</b>	<b>35,814</b>	<b>35,918</b>	<b>35,752</b>	<b>36,059</b>	<b>35,369</b>	<b>35,569</b>	<b>35,878</b>	<b>35,982</b>

\*Meets Tier 4 Final/Stage IV/Japan 2014 (Tier 4 Final) emission standards.

**NOTE:** Specifications and ratings conform to all applicable standards recommended by the Society of Automotive Engineers (SAE), including SAE Standards J732 (APR07) which governs loader ratings.

	Change in Operating Weight		Change in Articulated Static Tipping Load	
	kg	lb	kg	lb
Without Ride Control System	- 31	- 68	- 11	- 24
Without Guard, driveshaft	- 44	- 97	- 10	- 23
With Guard, windshield	34	75	16	34
Without Roading Fenders	- 41	- 90	- 24	- 54
Without Secondary Steering	- 53	- 117	- 42	- 92
Without Guard, crankcase	- 11	- 24	- 12	- 26
Without Guard, power train	- 67	- 148	- 50	- 111
With Guard, power train side	11	24	8	17
With Counterweight, Heavy	343	756	447	985
With Counterweight, Logger	N/A	N/A	N/A	N/A
With Cold Start 120V	54	119	72	159
With Product Link	8	18	6	14
With Guard, rear wastegate	276	608	404	891
<b>Tires, 3-piece rims</b>				
20.5-25, 16PR (L-3)	- 104	- 229	- 99	- 218
20.5-25, 16PR (L-5)	224	494	213	470
550/65 R25, Radial (L-3)	- 108	- 238	- 103	- 227
600/65 R25, Radial (L-3)	24	53	23	51
20.5 R25, Radial (L-5) XMINE D2	<b>616</b>	<b>1358</b>	<b>587</b>	1294
20.5 R25, Radial (L-2) VUT	- 188	- 414	- 179	- 395
20.5 R25, Radial (L-3) VJT	32	71	30	66
20.5 R25, Radial (L-3) VMT	44	97	42	93
20.5 R25, Radial (L-5) VSDL	792	1746	755	1664

Bucket Type		General Purpose								
		Bolt-on Cutting Edges			Bolt-on Teeth & Segments			Bolt-on Teeth		
<b>Ground Engaging Type</b>										
Rated bucket capacity	m <sup>3</sup>	2.50	2.70	2.90	2.50	2.70	2.90	2.40	2.60	2.80
	yd <sup>3</sup>	<b>3.27</b>	<b>3.53</b>	<b>3.79</b>	<b>3.27</b>	<b>3.53</b>	<b>3.79</b>	<b>3.14</b>	<b>3.40</b>	<b>3.66</b>
Struck capacity	m <sup>3</sup>	2.30	2.50	2.70	2.30	2.50	2.70	2.20	2.40	2.60
	yd <sup>3</sup>	<b>3.01</b>	<b>3.27</b>	<b>3.53</b>	<b>3.01</b>	<b>3.27</b>	<b>3.53</b>	<b>2.88</b>	<b>3.14</b>	<b>3.40</b>
Bucket width	mm	2750	2750	2750	2750	2750	2750	2750	2750	2750
	ft/in	<b>9'0"</b>	<b>9'0"</b>	<b>9'0"</b>	<b>9'0"</b>	<b>9'0"</b>	<b>9'0"</b>	<b>9'0"</b>	<b>9'0"</b>	<b>9'0"</b>
Dump clearance at full lift and 45° discharge	mm	2834	2787	2751	2729	2681	2644	2729	2681	2644
	ft/in	<b>9'4"</b>	<b>9'2"</b>	<b>9'0"</b>	<b>8'11"</b>	<b>8'10"</b>	<b>8'8"</b>	<b>8'11"</b>	<b>8'10"</b>	<b>8'8"</b>
Reach at full lift and 45° discharge	mm	1146	1185	1216	1248	1286	1316	1248	1286	1316
	ft/in	<b>3'9"</b>	<b>3'11"</b>	<b>4'0"</b>	<b>4'1"</b>	<b>4'3"</b>	<b>4'4"</b>	<b>4'1"</b>	<b>4'3"</b>	<b>4'4"</b>
Reach at 45° discharge and 2130 mm (7'0") clearance	mm	1658	1672	1684	1704	1714	1723	1704	1714	1723
	ft/in	<b>5'5"</b>	<b>5'6"</b>	<b>5'6"</b>	<b>5'7"</b>	<b>5'7"</b>	<b>5'8"</b>	<b>5'7"</b>	<b>5'7"</b>	<b>5'8"</b>
Reach with lift arms horizontal and bucket level	mm	2504	2566	2615	2650	2712	2761	2650	2712	2761
	ft/in	<b>8'3"</b>	<b>8'5"</b>	<b>8'7"</b>	<b>8'8"</b>	<b>8'11"</b>	<b>9'1"</b>	<b>8'8"</b>	<b>8'11"</b>	<b>9'1"</b>
Digging depth	mm	101	101	101	112	112	112	112	112	112
	in	<b>4.0</b>	<b>4.0</b>	<b>4.0</b>	<b>4.4</b>	<b>4.4</b>	<b>4.4</b>	<b>4.4</b>	<b>4.4</b>	<b>4.4</b>
Overall length	mm	7656	7718	7767	7802	7864	7913	7782	7844	7893
	ft/in	<b>25'1"</b>	<b>25'4"</b>	<b>25'6"</b>	<b>25'7"</b>	<b>25'10"</b>	<b>26'0"</b>	<b>25'6"</b>	<b>25'9"</b>	<b>25'11"</b>
Overall height with bucket at full raise	mm	5273	5332	5379	5273	5332	5379	5273	5332	5379
	ft/in	<b>17'4"</b>	<b>17'6"</b>	<b>17'8"</b>	<b>17'4"</b>	<b>17'6"</b>	<b>17'8"</b>	<b>17'4"</b>	<b>17'6"</b>	<b>17'8"</b>
Loader clearance radius with bucket in carry position	mm	6133	6152	6166	6181	6200	6215	6181	6200	6215
	ft/in	<b>20'1"</b>	<b>20'2"</b>	<b>20'3"</b>	<b>20'3"</b>	<b>20'4"</b>	<b>20'5"</b>	<b>20'3"</b>	<b>20'4"</b>	<b>20'5"</b>
Static tipping load straight	kg	11 820	11 721	11 641	11 682	11 582	11 500	11 784	11 685	11 604
	lb	<b>26,059</b>	<b>25,840</b>	<b>25,664</b>	<b>25,754</b>	<b>25,534</b>	<b>25,353</b>	<b>25,979</b>	<b>25,761</b>	<b>25,582</b>
Static tipping load with 40° turn	kg	10 028	9938	9864	9893	9802	9727	9993	9903	9829
	lb	<b>22,108</b>	<b>21,910</b>	<b>21,746</b>	<b>21,810</b>	<b>21,610</b>	<b>21,444</b>	<b>22,031</b>	<b>21,832</b>	<b>21,669</b>
Breakout force	kg	13 170	12 498	12 009	13 059	12 387	11 897	13 920	13 170	12 626
	lbf	<b>29,035</b>	<b>27,554</b>	<b>26,475</b>	<b>28,790</b>	<b>27,309</b>	<b>26,229</b>	<b>30,689</b>	<b>29,035</b>	<b>27,836</b>
Operating weight	kg	16 427	16 472	16 508	16 538	16 583	16 619	16 456	16 500	16 536
	lb	<b>36,215</b>	<b>36,315</b>	<b>36,394</b>	<b>36,460</b>	<b>36,559</b>	<b>36,639</b>	<b>36,279</b>	<b>36,376</b>	<b>36,456</b>

\*Meets Tier 4 Final/Stage IV/Japan 2014 (Tier 4 Final) emission standards.

**NOTE:** Specifications and ratings conform to all applicable standards recommended by the Society of Automotive Engineers (SAE), including SAE Standards J732 (APR07) which governs loader ratings.

# Wheel Loaders Integrated Toolcarriers

## Performance Data ● 938M\* Standard Lift Fusion Bucket

Bucket Type	Light Material									
	Ground Engaging Type	Bolt-on Cutting Edges			Bolt-on Teeth & Segments			Bolt-on Teeth		
Rated bucket capacity		m <sup>3</sup>	3.50	4.20	5.00	3.50	4.20	5.00	3.40	4.10
	yd <sup>3</sup>	<b>4.58</b>	<b>5.49</b>	<b>6.54</b>	<b>4.58</b>	<b>5.49</b>	<b>6.54</b>	<b>4.45</b>	<b>5.36</b>	<b>6.41</b>
Struck capacity	m <sup>3</sup>	3.30	4.00	4.80	3.30	4.00	4.80	3.20	3.90	4.70
	yd <sup>3</sup>	<b>4.32</b>	<b>5.23</b>	<b>6.28</b>	<b>4.32</b>	<b>5.23</b>	<b>6.28</b>	<b>4.19</b>	<b>5.10</b>	<b>6.15</b>
Bucket width	mm	2750	2750	2750	2750	2750	2750	2750	2750	2750
	ft/in	<b>9'0"</b>	<b>9'0"</b>	<b>9'0"</b>	<b>9'0"</b>	<b>9'0"</b>	<b>9'0"</b>	<b>9'0"</b>	<b>9'0"</b>	<b>9'0"</b>
Dump clearance at full lift and 45° discharge	mm	2654	2534	2534	2543	2422	2422	2543	2422	2422
	ft/in	<b>8'8"</b>	<b>8'4"</b>	<b>8'4"</b>	<b>8'4"</b>	<b>7'11"</b>	<b>7'11"</b>	<b>8'4"</b>	<b>7'11"</b>	<b>7'11"</b>
Reach at full lift and 45° discharge	mm	1210	1331	1331	1305	1426	1426	1305	1426	1426
	ft/in	<b>4'0"</b>	<b>4'4"</b>	<b>4'4"</b>	<b>4'3"</b>	<b>4'8"</b>	<b>4'8"</b>	<b>4'3"</b>	<b>4'8"</b>	<b>4'8"</b>
Reach at 45° discharge and 2130 mm (7'0") clearance	mm	1622	1666	1666	1646	1681	1681	1646	1681	1681
	ft/in	<b>5'4"</b>	<b>5'6"</b>	<b>5'6"</b>	<b>5'5"</b>	<b>5'6"</b>	<b>5'6"</b>	<b>5'5"</b>	<b>5'6"</b>	<b>5'6"</b>
Reach with lift arms horizontal and bucket level	mm	2694	2864	2864	2840	3010	3010	2840	3010	3010
	ft/in	<b>8'10"</b>	<b>9'5"</b>	<b>9'5"</b>	<b>9'4"</b>	<b>9'11"</b>	<b>9'11"</b>	<b>9'11"</b>	<b>9'11"</b>	<b>9'11"</b>
Digging depth	mm	101	101	101	112	112	112	112	112	112
	in	<b>4.0</b>	<b>4.0</b>	<b>4.0</b>	<b>4.4</b>	<b>4.4</b>	<b>4.4</b>	<b>4.4</b>	<b>4.4</b>	<b>4.4</b>
Overall length	mm	7846	8016	8016	7992	8162	8162	7972	8142	8142
	ft/in	<b>25'9"</b>	<b>26'4"</b>	<b>26'4"</b>	<b>26'3"</b>	<b>26'9"</b>	<b>26'9"</b>	<b>26'2"</b>	<b>26'9"</b>	<b>26'9"</b>
Overall height with bucket at full raise	mm	5376	5539	5820	5376	5539	5820	5376	5539	5820
	ft/in	<b>17'8"</b>	<b>18'2"</b>	<b>19'1"</b>	<b>17'8"</b>	<b>18'2"</b>	<b>19'1"</b>	<b>17'8"</b>	<b>18'2"</b>	<b>19'1"</b>
Loader clearance radius with bucket in carry position	mm	6190	6244	6244	6240	6295	6295	6240	6295	6295
	ft/in	<b>20'4"</b>	<b>20'6"</b>	<b>20'6"</b>	<b>20'6"</b>	<b>20'8"</b>	<b>20'8"</b>	<b>20'6"</b>	<b>20'8"</b>	<b>20'8"</b>
Static tipping load straight	kg	11 451	11 151	11 120	11 309	11 006	10 975	11 414	11 113	11 083
	lb	<b>25,245</b>	<b>24,584</b>	<b>24,515</b>	<b>24,932</b>	<b>24,264</b>	<b>24,196</b>	<b>25,164</b>	<b>24,500</b>	<b>24,434</b>
Static tipping load with 40° turn	kg	9689	9416	9383	9550	9275	9241	9653	9380	9347
	lb	<b>21,361</b>	<b>20,759</b>	<b>20,686</b>	<b>21,054</b>	<b>20,448</b>	<b>20,373</b>	<b>21,281</b>	<b>20,679</b>	<b>20,607</b>
Breakout force	kg	11 263	9936	9888	11 151	9825	9776	11 803	10 351	10 300
	lbf	<b>24,831</b>	<b>21,905</b>	<b>21,799</b>	<b>24,584</b>	<b>21,661</b>	<b>21,553</b>	<b>26,021</b>	<b>22,820</b>	<b>22,708</b>
Operating weight	kg	16 628	16 757	16 835	16 379	16 868	16 946	16 656	16 786	16 864
	lb	<b>36,658</b>	<b>36,943</b>	<b>37,115</b>	<b>36,109</b>	<b>37,188</b>	<b>37,359</b>	<b>36,720</b>	<b>37,007</b>	<b>37,179</b>

\*Meets Tier 4 Final/Stage IV/Japan 2014 (Tier 4 Final) emission standards.

**NOTE:** Specifications and ratings conform to all applicable standards recommended by the Society of Automotive Engineers (SAE), including SAE Standards J732 (APR07) which governs loader ratings.

	Change in Operating Weight		Change in Articulated Static Tipping Load	
	kg	lb	kg	lb
Without Ride Control System	- 31	- 68	- 14	- 30
Without Guard, driveshaft	- 44	- 97	- 13	- 29
With Guard, windshield	34	75	20	43
Without Roading Fenders	- 41	- 90	- 30	- 67
Without Secondary Steering	- 53	- 117	- 52	- 115
Without Guard, crankcase	- 11	- 24	- 15	- 33
Without Guard, power train	- 67	- 148	- 63	- 140
With Guard, power train side	11	24	10	21
Without Counterweight, Heavy	- 343	- 756	- 561	- 1236
With Counterweight, Logger	299	658	402	886
With Cold Start 120V	54	119	90	199
With Product Link	8	18	8	17
With Guard, rear wastegate	276	608	508	1119
<b>Tires, 3-piece rims</b>				
20.5-25, 16PR (L-3)	- 104	- 229	- 124	- 273
20.5-25, 16PR (L-5)	224	494	268	591
550/65 R25, Radial (L-3)	- 108	- 238	- 129	- 284
600/65 R25, Radial (L-3)	24	53	29	64
20.5 R25, Radial (L-5) XMINE D2	<b>616</b>	<b>1358</b>	<b>737</b>	1625
20.5 R25, Radial (L-2) VUT	- 188	- 414	- 225	- 496
20.5 R25, Radial (L-3) VJT	32	71	38	84
20.5 R25, Radial (L-3) VMT	44	97	53	117
20.5 R25, Radial (L-5) VSDL	792	1746	948	2090

Bucket Type		General Purpose								
		Bolt-on Cutting Edges			Bolt-on Teeth & Segments			Bolt-on Teeth		
<b>Ground Engaging Type</b>										
Rated bucket capacity	m <sup>3</sup>	2.50	2.70	2.90	2.50	2.70	2.90	2.40	2.60	2.80
	yd <sup>3</sup>	<b>3.27</b>	<b>3.53</b>	<b>3.79</b>	<b>3.27</b>	<b>3.53</b>	<b>3.79</b>	<b>3.14</b>	<b>3.40</b>	<b>3.66</b>
Struck capacity	m <sup>3</sup>	2.30	2.50	2.70	2.30	2.50	2.70	2.20	2.40	2.60
	yd <sup>3</sup>	<b>3.01</b>	<b>3.27</b>	<b>3.53</b>	<b>3.01</b>	<b>3.27</b>	<b>3.53</b>	<b>2.88</b>	<b>3.14</b>	<b>3.40</b>
Bucket width	mm	2750	2750	2750	2750	2750	2750	2750	2750	2750
	ft/in	<b>9'0"</b>	<b>9'0"</b>	<b>9'0"</b>	<b>9'0"</b>	<b>9'0"</b>	<b>9'0"</b>	<b>9'0"</b>	<b>9'0"</b>	<b>9'0"</b>
Dump clearance at full lift and 45° discharge	mm	3415	3368	3332	3310	3262	3225	3310	3262	3225
	ft/in	<b>11'2"</b>	<b>11'1"</b>	<b>10'11"</b>	<b>10'10"</b>	<b>10'8"</b>	<b>10'7"</b>	<b>10'10"</b>	<b>10'8"</b>	<b>10'7"</b>
Reach at full lift and 45° discharge	mm	1413	1451	1482	1515	1552	1583	1515	1552	1583
	ft/in	<b>4'8"</b>	<b>4'9"</b>	<b>4'10"</b>	<b>5'0"</b>	<b>5'1"</b>	<b>5'2"</b>	<b>5'0"</b>	<b>5'1"</b>	<b>5'2"</b>
Reach at 45° discharge and 2130 mm (7'0") clearance	mm	2323	2343	2358	2381	2398	2411	2381	2398	2411
	ft/in	<b>7'7"</b>	<b>7'8"</b>	<b>7'9"</b>	<b>7'10"</b>	<b>7'10"</b>	<b>7'11"</b>	<b>7'10"</b>	<b>7'10"</b>	<b>7'11"</b>
Reach with lift arms horizontal and bucket level	mm	3111	3173	3222	3257	3319	3368	3257	3319	3368
	ft/in	<b>10'2"</b>	<b>10'5"</b>	<b>10'7"</b>	<b>10'8"</b>	<b>10'11"</b>	<b>11'1"</b>	<b>10'8"</b>	<b>10'11"</b>	<b>11'1"</b>
Digging depth	mm	135	135	135	147	147	147	147	147	147
	in	<b>5.3</b>	<b>5.3</b>	<b>5.3</b>	<b>5.8</b>	<b>5.8</b>	<b>5.8</b>	<b>5.8</b>	<b>5.8</b>	<b>5.8</b>
Overall length	mm	8397	8459	8508	8543	8605	8654	8527	8589	8638
	ft/in	<b>27'7"</b>	<b>27'9"</b>	<b>27'11"</b>	<b>28'0"</b>	<b>28'3"</b>	<b>28'5"</b>	<b>28'0"</b>	<b>28'2"</b>	<b>28'4"</b>
Overall height with bucket at full raise	mm	5853	5912	5960	5853	5912	5960	5853	5912	5960
	ft/in	<b>19'2"</b>	<b>19'5"</b>	<b>19'7"</b>	<b>19'2"</b>	<b>19'5"</b>	<b>19'7"</b>	<b>19'2"</b>	<b>19'5"</b>	<b>19'7"</b>
Loader clearance radius with bucket in carry position	mm	6490	6511	6527	6544	6565	6582	6544	6565	6582
	ft/in	<b>21'4"</b>	<b>21'4"</b>	<b>21'5"</b>	<b>21'6"</b>	<b>21'6"</b>	<b>21'7"</b>	<b>21'6"</b>	<b>21'6"</b>	<b>21'7"</b>
Static tipping load straight	kg	8257	8182	8121	8126	8050	7988	8223	8148	8086
	lb	<b>18,204</b>	<b>18,038</b>	<b>17,904</b>	<b>17,915</b>	<b>17,747</b>	<b>17,611</b>	<b>18,129</b>	<b>17,963</b>	<b>17,827</b>
Static tipping load with 40° turn	kg	6939	6869	6812	6810	6740	6682	6906	6836	6779
	lb	<b>15,298</b>	<b>15,144</b>	<b>15,018</b>	<b>15,013</b>	<b>14,859</b>	<b>14,731</b>	<b>15,225</b>	<b>15,071</b>	<b>14,945</b>
Breakout force	kg	12 663	12 015	11 543	12 552	11 904	11 432	13 379	12 656	12 132
	lbf	<b>27,917</b>	<b>26,489</b>	<b>25,448</b>	<b>27,673</b>	<b>26,244</b>	<b>25,203</b>	<b>29,496</b>	<b>27,902</b>	<b>26,747</b>
Operating weight	kg	16 326	16 370	16 406	16 436	16 481	16 517	16 354	16 398	16 435
	lb	<b>35,993</b>	<b>36,090</b>	<b>36,169</b>	<b>36,235</b>	<b>36,334</b>	<b>36,414</b>	<b>36,054</b>	<b>36,151</b>	<b>36,233</b>

\*Meets Tier 4 Final/Stage IV/Japan 2014 (Tier 4 Final) emission standards.

**NOTE:** Specifications and ratings conform to all applicable standards recommended by the Society of Automotive Engineers (SAE), including SAE Standards J732 (APR07) which governs loader ratings.

# Wheel Loaders Integrated Toolcarriers

## Performance Data ● 938M\* High Lift Fusion Bucket

Bucket Type	Light Material									
	Ground Engaging Type	Bolt-on Cutting Edges			Bolt-on Teeth & Segments			Bolt-on Teeth		
Rated bucket capacity		m <sup>3</sup>	3.50	4.20	5.00	3.50	4.20	5.00	3.40	4.10
	yd <sup>3</sup>	<b>4.58</b>	<b>5.49</b>	<b>6.54</b>	<b>4.58</b>	<b>5.49</b>	<b>6.54</b>	<b>4.45</b>	<b>5.36</b>	<b>6.41</b>
Struck capacity	m <sup>3</sup>	3.30	4.00	4.80	3.30	4.00	4.80	3.20	3.90	4.70
	yd <sup>3</sup>	<b>4.32</b>	<b>5.23</b>	<b>6.28</b>	<b>4.32</b>	<b>5.23</b>	<b>6.28</b>	<b>4.19</b>	<b>5.10</b>	<b>6.15</b>
Bucket width	mm	2750	2750	2750	2750	2750	2750	2750	2750	2750
	ft/in	<b>9'0"</b>	<b>9'0"</b>	<b>9'0"</b>	<b>9'0"</b>	<b>9'0"</b>	<b>9'0"</b>	<b>9'0"</b>	<b>9'0"</b>	<b>9'0"</b>
Dump clearance at full lift and 45° discharge	mm	3235	3115	3115	3124	3003	3003	3124	3003	3003
	ft/in	<b>10'7"</b>	<b>10'3"</b>	<b>10'3"</b>	<b>10'3"</b>	<b>9'10"</b>	<b>9'10"</b>	<b>10'3"</b>	<b>9'10"</b>	<b>9'10"</b>
Reach at full lift and 45° discharge	mm	1477	1597	1597	1572	1692	1692	1572	1692	1692
	ft/in	<b>4'10"</b>	<b>5'3"</b>	<b>5'3"</b>	<b>5'2"</b>	<b>5'7"</b>	<b>5'7"</b>	<b>5'2"</b>	<b>5'7"</b>	<b>5'7"</b>
Reach at 45° discharge and 2130 mm (7'0") clearance	mm	2310	2371	2371	2350	2406	2406	2350	2406	2406
	ft/in	<b>7'7"</b>	<b>7'9"</b>	<b>7'9"</b>	<b>7'9"</b>	<b>7'11"</b>	<b>7'11"</b>	<b>7'9"</b>	<b>7'11"</b>	<b>7'11"</b>
Reach with lift arms horizontal and bucket level	mm	3301	3471	3471	3447	3617	3617	3447	3617	3617
	ft/in	<b>10'10"</b>	<b>11'5"</b>	<b>11'5"</b>	<b>11'4"</b>	<b>11'10"</b>	<b>11'10"</b>	<b>11'4"</b>	<b>11'10"</b>	<b>11'10"</b>
Digging depth	mm	135	135	135	147	147	147	147	147	147
	in	<b>5.3</b>	<b>5.3</b>	<b>5.3</b>	<b>5.8</b>	<b>5.8</b>	<b>5.8</b>	<b>5.8</b>	<b>5.8</b>	<b>5.8</b>
Overall length	mm	8587	8757	8757	8733	8903	8903	8717	8887	8887
	ft/in	<b>28'2"</b>	<b>28'9"</b>	<b>28'9"</b>	<b>28'8"</b>	<b>29'2"</b>	<b>29'2"</b>	<b>28'7"</b>	<b>29'2"</b>	<b>29'2"</b>
Overall height with bucket at full raise	mm	5957	6120	6401	5957	6120	6401	5957	6120	6401
	ft/in	<b>19'7"</b>	<b>20'1"</b>	<b>21'0"</b>	<b>19'7"</b>	<b>20'1"</b>	<b>21'0"</b>	<b>19'7"</b>	<b>20'1"</b>	<b>21'0"</b>
Loader clearance radius with bucket in carry position	mm	6554	6613	6613	6609	6669	6669	6609	6669	6669
	ft/in	<b>21'6"</b>	<b>21'8"</b>	<b>21'8"</b>	<b>21'8"</b>	<b>21'11"</b>	<b>21'11"</b>	<b>21'8"</b>	<b>21'11"</b>	<b>21'11"</b>
Static tipping load straight	kg	7965	7739	7693	7831	7602	7556	7930	7704	7657
	lb	<b>17,560</b>	<b>17,062</b>	<b>16,960</b>	<b>17,264</b>	<b>16,760</b>	<b>16,658</b>	<b>17,483</b>	<b>16,984</b>	<b>16,881</b>
Static tipping load with 40° turn	kg	6666	6457	6410	6534	6323	6276	6632	6423	6376
	lb	<b>14,696</b>	<b>14,235</b>	<b>14,132</b>	<b>14,405</b>	<b>13,940</b>	<b>13,836</b>	<b>14,621</b>	<b>14,160</b>	<b>14,057</b>
Breakout force	kg	10 823	9543	9495	10 711	9432	9383	11 337	9937	9886
	lbf	<b>23,861</b>	<b>21,039</b>	<b>20,933</b>	<b>23,614</b>	<b>20,794</b>	<b>20,686</b>	<b>24,994</b>	<b>21,907</b>	<b>21,795</b>
Operating weight	kg	16 526	16 656	16 733	16 637	16 766	16 844	16 554	16 684	16 762
	lb	<b>36,434</b>	<b>36,720</b>	<b>36,890</b>	<b>36,678</b>	<b>36,963</b>	<b>37,135</b>	<b>36,495</b>	<b>36,782</b>	<b>36,954</b>

\*Meets Tier 4 Final/Stage IV/Japan 2014 (Tier 4 Final) emission standards.

**NOTE:** Specifications and ratings conform to all applicable standards recommended by the Society of Automotive Engineers (SAE), including SAE Standards J732 (APR07) which governs loader ratings.

	Change in Operating Weight		Change in Articulated Static Tipping Load	
	kg	lb	kg	lb
Without Ride Control System	- 31	- 68	- 11	- 24
Without Guard, driveshaft	- 44	- 97	- 10	- 23
With Guard, windshield	34	75	15	34
Without Roading Fenders	- 41	- 90	- 24	- 53
Without Secondary Steering	- 53	- 117	- 41	- 91
Without Guard, crankcase	- 11	- 24	- 12	- 26
Without Guard, power train	- 67	- 148	- 50	- 110
With Guard, power train side	11	24	8	17
With Counterweight, Heavy	343	756	447	985
With Counterweight, Logger	N/A	N/A	N/A	N/A
With Cold Start 120V	54	119	71	157
With Product Link	8	18	6	14
With Guard, rear wastegate	276	608	399	881
<b>Tires, 3-piece rims</b>				
20.5-25, 16PR (L-3)	- 104	- 229	- 98	- 216
20.5-25, 16PR (L-5)	224	494	211	465
550/65 R25, Radial (L-3)	- 108	- 238	- 102	- 225
600/65 R25, Radial (L-3)	24	53	23	51
20.5 R25, Radial (L-5) XMINE D2	<b>616</b>	<b>1358</b>	<b>580</b>	<b>1279</b>
20.5 R25, Radial (L-2) VUT	- 188	- 414	- 177	- 390
20.5 R25, Radial (L-3) VJT	32	71	30	66
20.5 R25, Radial (L-3) VMT	44	97	41	90
20.5 R25, Radial (L-5) VSDL	792	1746	746	1645

Bucket Type Ground Engaging Type		General Purpose							
		Bolt-on Cutting Edges				Bolt-on Teeth & Segments			
Rated bucket capacity	m <sup>3</sup>	2.10	2.30	2.70	2.90	2.10	2.30	2.70	2.90
	yd <sup>3</sup>	<b>2.75</b>	<b>3.01</b>	<b>3.53</b>	<b>3.79</b>	<b>2.75</b>	<b>3.01</b>	<b>3.53</b>	<b>3.79</b>
Struck capacity	m <sup>3</sup>	2.00	2.20	2.60	2.70	2.00	2.20	2.60	2.70
	yd <sup>3</sup>	<b>2.62</b>	<b>2.88</b>	<b>3.40</b>	<b>3.53</b>	<b>2.62</b>	<b>2.88</b>	<b>3.40</b>	<b>3.53</b>
Bucket width	mm	2550	2550	2750	2750	2550	2550	2750	2750
	ft/in	<b>8'4"</b>	<b>8'4"</b>	<b>9'0"</b>	<b>9'0"</b>	<b>8'4"</b>	<b>8'4"</b>	<b>9'0"</b>	<b>9'0"</b>
Dump clearance at full lift and 45° discharge	mm	2809	2760	2712	2675	2704	2654	2606	2569
	ft/in	<b>9'3"</b>	<b>9'1"</b>	<b>8'11"</b>	<b>8'9"</b>	<b>8'10"</b>	<b>8'8"</b>	<b>8'7"</b>	<b>8'5"</b>
Reach at full lift and 45° discharge	mm	1206	1242	1280	1311	1308	1344	1381	1411
	ft/in	<b>3'11"</b>	<b>4'1"</b>	<b>4'2"</b>	<b>4'4"</b>	<b>4'3"</b>	<b>4'5"</b>	<b>4'6"</b>	<b>4'8"</b>
Reach at 45° discharge and 2130 mm (7'0") clearance	mm	1704	1715	1726	1735	1750	1756	1763	1770
	ft/in	<b>5'7"</b>	<b>5'8"</b>	<b>5'8"</b>	<b>5'8"</b>	<b>5'9"</b>	<b>5'9"</b>	<b>5'9"</b>	<b>5'10"</b>
Reach with lift arms horizontal and bucket level	mm	2562	2625	2687	2736	2708	2771	2833	2882
	ft/in	<b>8'5"</b>	<b>8'7"</b>	<b>8'10"</b>	<b>9'0"</b>	<b>8'11"</b>	<b>9'1"</b>	<b>9'4"</b>	<b>9'5"</b>
Digging depth	mm	93	93	93	93	105	105	105	105
	in	<b>3.7</b>	<b>3.7</b>	<b>3.7</b>	<b>3.7</b>	<b>4.1</b>	<b>4.1</b>	<b>4.1</b>	<b>4.1</b>
Overall length	mm	7708	7771	7833	7882	7854	7917	7979	8028
	ft/in	<b>25'3"</b>	<b>25'6"</b>	<b>25'8"</b>	<b>25'10"</b>	<b>25'9"</b>	<b>26'0"</b>	<b>26'2"</b>	<b>26'4"</b>
Overall height with bucket at full raise	mm	5298	5356	5415	5462	5298	5356	5415	5462
	ft/in	<b>17'5"</b>	<b>17'7"</b>	<b>17'9"</b>	<b>17'11"</b>	<b>17'5"</b>	<b>17'7"</b>	<b>17'9"</b>	<b>17'11"</b>
Loader clearance radius with bucket in carry position	mm	6039	6059	6169	6185	6090	6110	6221	6237
	ft/in	<b>19'10"</b>	<b>19'11"</b>	<b>20'3"</b>	<b>20'4"</b>	<b>20'0"</b>	<b>20'1"</b>	<b>20'5"</b>	<b>20'6"</b>
Static tipping load straight	kg	11 536	11 446	11 245	11 171	11 389	11 298	11 107	11 032
	lb	<b>25,432</b>	<b>25,234</b>	<b>24,791</b>	<b>24,628</b>	<b>25,108</b>	<b>24,908</b>	<b>24,487</b>	<b>24,321</b>
Static tipping load with 40° turn	kg	9809	9727	9536	9469	9665	9581	9401	9332
	lb	<b>21,625</b>	<b>21,444</b>	<b>21,023</b>	<b>20,876</b>	<b>21,308</b>	<b>21,122</b>	<b>20,726</b>	<b>20,574</b>
Breakout force	kg	12 542	11 922	11 299	10 887	12 422	11 802	11 187	10 775
	lbf	<b>27,651</b>	<b>26,284</b>	<b>24,910</b>	<b>24,002</b>	<b>27,386</b>	<b>26,019</b>	<b>24,663</b>	<b>23,755</b>
Operating weight	kg	16 175	16 213	16 367	16 401	16 295	16 333	16 478	16 512
	lb	<b>35,660</b>	<b>35,744</b>	<b>36,083</b>	<b>36,158</b>	<b>35,924</b>	<b>36,008</b>	<b>36,328</b>	<b>36,403</b>

\*Meets Tier 4 Final/Stage IV/Japan 2014 (Tier 4 Final) emission standards.

NOTE: Specifications and ratings conform to all applicable standards recommended by the Society of Automotive Engineers (SAE), including SAE Standards J732 (APR07) which governs loader ratings.

# Wheel Loaders Integrated Toolcarriers

## Performance Data ● 938M\* Standard Lift ISO Bucket

Bucket Type		General Purpose			
Ground Engaging Type		Bolt-on Teeth			
Rated bucket capacity	m <sup>3</sup>	2.00	2.20	2.60	2.80
	yd <sup>3</sup>	<b>2.62</b>	<b>2.88</b>	<b>3.40</b>	<b>3.66</b>
Struck capacity	m <sup>3</sup>	1.90	2.10	2.50	2.60
	yd <sup>3</sup>	<b>2.49</b>	<b>2.75</b>	<b>3.27</b>	<b>3.40</b>
Bucket width	mm	2550	2550	2750	2750
	ft/in	<b>8'4"</b>	<b>8'4"</b>	<b>9'0"</b>	<b>9'0"</b>
Dump clearance at full lift and 45° discharge	mm	2704	2654	2606	2569
	ft/in	<b>8'10"</b>	<b>8'8"</b>	<b>8'7"</b>	<b>8'5"</b>
Reach at full lift and 45° discharge	mm	1308	1344	1381	1411
	ft/in	<b>4'3"</b>	<b>4'5"</b>	<b>4'6"</b>	<b>4'8"</b>
Reach at 45° discharge and 2130 mm (7'0") clearance	mm	1750	1756	1763	1770
	ft/in	<b>5'9"</b>	<b>5'9"</b>	<b>5'9"</b>	<b>5'10"</b>
Reach with lift arms horizontal and bucket level	mm	2708	2771	2833	2882
	ft/in	<b>8'11"</b>	<b>9'1"</b>	<b>9'4"</b>	<b>9'5"</b>
Digging depth	mm	105	105	105	105
	in	<b>4.1</b>	<b>4.1</b>	<b>4.1</b>	<b>4.1</b>
Overall length	mm	7833	7896	7958	8007
	ft/in	<b>25'8"</b>	<b>25'11"</b>	<b>26'1"</b>	<b>26'3"</b>
Overall height with bucket at full raise	mm	5298	5356	5415	5462
	ft/in	<b>17'5"</b>	<b>17'7"</b>	<b>17'9"</b>	<b>17'11"</b>
Loader clearance radius with bucket in carry position	mm	6090	6110	6221	6237
	ft/in	<b>20'0"</b>	<b>20'1"</b>	<b>20'5"</b>	<b>20'6"</b>
Static tipping load straight	kg	11 490	11 399	11 210	11 135
	lb	<b>25,331</b>	<b>25,130</b>	<b>24,714</b>	<b>24,548</b>
Static tipping load with 40° turn	kg	9763	9681	9502	9433
	lb	<b>21,524</b>	<b>21,343</b>	<b>20,948</b>	<b>20,796</b>
Breakout force	kg	13 206	12 517	11 841	11 387
	lbf	<b>29,114</b>	<b>27,595</b>	<b>26,105</b>	<b>25,104</b>
Operating weight	kg	16 213	16 251	16 396	16 430
	lb	<b>35,744</b>	<b>35,827</b>	<b>36,147</b>	<b>36,222</b>

\*Meets Tier 4 Final/Stage IV/Japan 2014 (Tier 4 Final) emission standards.

**NOTE:** Specifications and ratings conform to all applicable standards recommended by the Society of Automotive Engineers (SAE), including SAE Standards J732 (APR07) which governs loader ratings.

	Change in Operating Weight		Change in Articulated Static Tipping Load	
	kg	lb	kg	lb
Without Ride Control System .....	- 31	- 68	- 13	- 29
Without Guard, driveshaft .....	- 44	- 97	- 13	- 28
With Guard, windshield .....	34	75	19	42
Without Rooding Fenders .....	- 41	- 90	- 29	- 65
Without Secondary Steering .....	- 53	- 117	- 51	- 112
Without Guard, crankcase .....	- 11	- 24	- 14	- 32
Without Guard, power train .....	- 67	- 148	- 61	- 135
With Guard, power train side .....	11	24	9	21
Without Counterweight, Heavy .....	- 343	- 756	- 542	- 1195
With Counterweight, Logger .....	299	658	402	886
With Cold Start 120V .....	54	119	87	192
With Product Link .....	8	18	8	17
With Guard, rear wastegate .....	276	608	491	1082
<b>Tires, 3-piece rims</b>				
20.5-25, 16PR (L-3) .....	- 104	- 229	- 120	- 265
20.5-25, 16PR (L-5) .....	224	494	259	571
550/65 R25, Radial (L-3) .....	- 108	- 238	- 125	- 276
600/65 R25, Radial (L-3) .....	24	53	28	62
20.5 R25, Radial (L-5) XMINE D2 .....	<b>616</b>	<b>1358</b>	<b>712</b>	1570
20.5 R25, Radial (L-2) VUT .....	- 188	- 414	- 217	- 478
20.5 R25, Radial (L-3) VJT .....	32	71	37	82
20.5 R25, Radial (L-3) VMT .....	44	97	51	112
20.5 R25, Radial (L-5) VSDL .....	792	1746	916	2019

Bucket Type	Ground Engaging Type	General Purpose							
		Bolt-on Cutting Edges				Bolt-on Teeth & Segments			
Rated bucket capacity	m <sup>3</sup>	2.10	2.30	2.70	2.90	2.10	2.30	2.70	2.90
	yd <sup>3</sup>	<b>2.75</b>	<b>3.01</b>	<b>3.53</b>	<b>3.79</b>	<b>2.75</b>	<b>3.01</b>	<b>3.53</b>	<b>3.79</b>
Struck capacity	m <sup>3</sup>	2.00	2.20	2.60	2.70	2.00	2.20	2.60	2.70
	yd <sup>3</sup>	<b>2.62</b>	<b>2.88</b>	<b>3.40</b>	<b>3.53</b>	<b>2.62</b>	<b>2.88</b>	<b>3.40</b>	<b>3.53</b>
Bucket width	mm	2550	2550	2750	2750	2550	2550	2750	2750
	ft/in	<b>8'4"</b>	<b>8'4"</b>	<b>9'0"</b>	<b>9'0"</b>	<b>8'4"</b>	<b>8'4"</b>	<b>9'0"</b>	<b>9'0"</b>
Dump clearance at full lift and 45° discharge	mm	3390	3340	3293	3256	3285	3235	3187	3150
	ft/in	<b>11'1"</b>	<b>10'11"</b>	<b>10'10"</b>	<b>10'8"</b>	<b>10'9"</b>	<b>10'7"</b>	<b>10'5"</b>	<b>10'4"</b>
Reach at full lift and 45° discharge	mm	1472	1509	1547	1577	1575	1611	1648	1678
	ft/in	<b>4'10"</b>	<b>4'11"</b>	<b>5'1"</b>	<b>5'2"</b>	<b>5'2"</b>	<b>5'3"</b>	<b>5'5"</b>	<b>5'6"</b>
Reach at 45° discharge and 2130 mm (7'0") clearance	mm	2372	2389	2406	2420	2430	2443	2458	2469
	ft/in	<b>7'9"</b>	<b>7'10"</b>	<b>7'11"</b>	<b>7'11"</b>	<b>8'0"</b>	<b>8'0"</b>	<b>8'1"</b>	<b>8'1"</b>
Reach with lift arms horizontal and bucket level	mm	3169	3232	3294	3343	3315	3378	3440	3489
	ft/in	<b>10'5"</b>	<b>10'7"</b>	<b>10'10"</b>	<b>11'0"</b>	<b>10'11"</b>	<b>11'1"</b>	<b>11'3"</b>	<b>11'5"</b>
Digging depth	mm	128	128	128	128	139	139	139	139
	in	<b>5.0</b>	<b>5.0</b>	<b>5.0</b>	<b>5.0</b>	<b>5.5</b>	<b>5.5</b>	<b>5.5</b>	<b>5.5</b>
Overall length	mm	8450	8513	8575	8624	8596	8659	8721	8770
	ft/in	<b>27'9"</b>	<b>27'11"</b>	<b>28'2"</b>	<b>28'4"</b>	<b>28'2"</b>	<b>28'5"</b>	<b>28'7"</b>	<b>28'9"</b>
Overall height with bucket at full raise	mm	5879	5937	5996	6043	5879	5937	5996	6043
	ft/in	<b>19'3"</b>	<b>19'6"</b>	<b>19'8"</b>	<b>19'10"</b>	<b>19'3"</b>	<b>19'6"</b>	<b>19'8"</b>	<b>19'10"</b>
Loader clearance radius with bucket in carry position	mm	6410	6433	6540	6558	6468	6491	6598	6616
	ft/in	<b>21'0"</b>	<b>21'1"</b>	<b>21'5"</b>	<b>21'6"</b>	<b>21'3"</b>	<b>21'4"</b>	<b>21'8"</b>	<b>21'8"</b>
Static tipping load straight	kg	8188	8120	8144	8075	8144	8075	7907	7850
	lb	<b>18,051</b>	<b>17,902</b>	<b>17,954</b>	<b>17,802</b>	<b>17,954</b>	<b>17,802</b>	<b>17,432</b>	<b>17,306</b>
Static tipping load with 40° turn	kg	6906	6843	6862	6799	6862	6799	6638	6585
	lb	<b>15,225</b>	<b>15,086</b>	<b>15,128</b>	<b>14,989</b>	<b>15,128</b>	<b>14,989</b>	<b>14,634</b>	<b>14,517</b>
Breakout force	kg	12 052	11 455	10 852	10 454	11 932	11 334	10 740	10 343
	lbf	<b>26,570</b>	<b>25,254</b>	<b>23,925</b>	<b>23,047</b>	<b>26,306</b>	<b>24,987</b>	<b>23,678</b>	<b>22,803</b>
Operating weight	kg	16 073	16 111	16 117	16 149	16 111	16 149	16 294	16 328
	lb	<b>35,435</b>	<b>35,519</b>	<b>35,532</b>	<b>35,602</b>	<b>35,519</b>	<b>35,602</b>	<b>35,922</b>	<b>35,997</b>

\*Meets Tier 4 Final/Stage IV/Japan 2014 (Tier 4 Final) emission standards.

NOTE: Specifications and ratings conform to all applicable standards recommended by the Society of Automotive Engineers (SAE), including SAE Standards J732 (APR07) which governs loader ratings.



# Wheel Loaders Integrated Toolcarriers

## Performance Data ● 938M\* High Lift ISO Bucket

Bucket Type		General Purpose			
Ground Engaging Type		Bolt-on Teeth			
Rated bucket capacity	m <sup>3</sup>	2.00	2.20	2.60	2.80
	yd <sup>3</sup>	<b>2.62</b>	<b>2.88</b>	<b>3.40</b>	<b>3.66</b>
Struck capacity	m <sup>3</sup>	1.90	2.10	2.50	2.60
	yd <sup>3</sup>	<b>2.49</b>	<b>2.75</b>	<b>3.27</b>	<b>3.40</b>
Bucket width	mm	2550	2550	2750	2750
	ft/in	<b>8'4"</b>	<b>8'4"</b>	<b>9'0"</b>	<b>9'0"</b>
Dump clearance at full lift and 45° discharge	mm	3285	3235	3187	3150
	ft/in	<b>10'9"</b>	<b>10'7"</b>	<b>10'5"</b>	<b>10'4"</b>
Reach at full lift and 45° discharge	mm	1575	1611	1648	1678
	ft/in	<b>5'2"</b>	<b>5'3"</b>	<b>5'5"</b>	<b>5'6"</b>
Reach at 45° discharge and 2130 mm (7'0") clearance	mm	2430	2443	2458	2469
	ft/in	<b>8'0"</b>	<b>8'0"</b>	<b>8'1"</b>	<b>8'1"</b>
Reach with lift arms horizontal and bucket level	mm	3315	3378	3440	3489
	ft/in	<b>10'11"</b>	<b>11'1"</b>	<b>11'3"</b>	<b>11'5"</b>
Digging depth	mm	139	139	139	139
	in	<b>5.5</b>	<b>5.5</b>	<b>5.5</b>	<b>5.5</b>
Overall length	mm	8581	8644	8706	8755
	ft/in	<b>28'2"</b>	<b>28'4"</b>	<b>28'7"</b>	<b>28'9"</b>
Overall height with bucket at full raise	mm	5879	5937	5996	6043
	ft/in	<b>19'3"</b>	<b>19'6"</b>	<b>19'8"</b>	<b>19'10"</b>
Loader clearance radius with bucket in carry position	mm	6468	6491	6598	6616
	ft/in	<b>21'3"</b>	<b>21'4"</b>	<b>21'8"</b>	<b>21'8"</b>
Static tipping load straight	kg	8144	8075	7907	7850
	lb	<b>17,954</b>	<b>17,802</b>	<b>17,432</b>	<b>17,306</b>
Static tipping load with 40° turn	kg	6862	6799	6638	6585
	lb	<b>15,128</b>	<b>14,989</b>	<b>14,634</b>	<b>14,517</b>
Breakout force	kg	12 686	12 022	11 369	10 932
	lbf	<b>27,968</b>	<b>26,504</b>	<b>25,064</b>	<b>24,101</b>
Operating weight	kg	16 111	16 149	16 294	16 328
	lb	<b>35,519</b>	<b>35,602</b>	<b>35,922</b>	<b>35,997</b>

\*Meets Tier 4 Final/Stage IV/Japan 2014 (Tier 4 Final) emission standards.

**NOTE:** Specifications and ratings conform to all applicable standards recommended by the Society of Automotive Engineers (SAE), including SAE Standards J732 (APR07) which governs loader ratings.

	Change in Operating Weight		Change in Articulated Static Tipping Load	
	kg	lb	kg	lb
Without Ride Control System	- 31	- 68	- 10	- 23
Without Guard, driveshaft	- 44	- 97	- 10	- 22
With Guard, windshield	34	75	15	33
Without Rooding Fenders	- 41	- 90	- 23	- 51
Without Secondary Steering	- 53	- 117	- 40	- 88
Without Guard, crankcase	- 11	- 24	- 11	- 25
Without Guard, power train	- 67	- 148	- 49	- 107
With Guard, power train side	11	24	7	16
With Counterweight, Heavy	343	756	447	985
With Counterweight, Logger	N/A	N/A	N/A	N/A
With Cold Start 120V	54	119	69	153
With Product Link	8	18	6	13
With Guard, rear wastegate	276	608	389	857
<b>Tires, 3-piece rims</b>				
20.5-25, 16PR (L-3)	- 104	- 229	- 95	- 209
20.5-25, 16PR (L-5)	224	494	205	452
550/65 R25, Radial (L-3)	- 108	- 238	- 99	- 218
600/65 R25, Radial (L-3)	24	53	22	49
20.5 R25, Radial (L-5) XMINE D2	616	1358	564	1243
20.5 R25, Radial (L-2) VUT	- 188	- 414	- 172	- 379
20.5 R25, Radial (L-3) VJT	32	71	29	64
20.5 R25, Radial (L-3) VMT	44	97	40	88
20.5 R25, Radial (L-5) VSDL	792	1746	726	1601

- Performance Data  
 ● 938M\* Standard Lift  
 ● Pallet Forks ● Construction Forks

Wheel Loaders  
 Integrated Toolcarriers

		Pallet Forks – Fusion		
Fork tine length	mm	1220	1370	1524
	ft/in	4'0"	4'6"	5'0"
Ground to top of tine clearance	mm	3758	3758	3758
	ft/in	12'4"	12'4"	12'4"
Reach with lift arms horizontal and forks level	mm	1617	1617	1617
	ft/in	5'4"	5'4"	5'4"
Overall length	mm	7942	8092	8246
	ft/in	26'1"	26'7"	27'1"
Static tipping load with level arms and forks, straight	kg	9274	9022	8775
	lb	20,446	19,890	19,346
Static tipping load with level arms and forks, full 40° turn	kg	7909	7692	7478
	lb	17,436	16,958	16,486
Operating weight	kg	15 932	15 953	15 975
	lb	35,124	35,170	35,219

		Pallet Forks – ISO		
Fork tine length	mm	1220	1370	1524
	ft/in	4'0"	4'6"	5'0"
Ground to top of tine clearance	mm	3755	3755	3755
	ft/in	12'4"	12'4"	12'4"
Reach with lift arms horizontal and forks level	mm	1634	1634	1634
	ft/in	5'4"	5'4"	5'4"
Overall length	mm	7966	8116	8270
	ft/in	26'2"	26'8"	27'2"
Static tipping load with level arms and forks, straight	kg	9221	8974	8731
	lb	20,329	19,784	19,249
Static tipping load with level arms and forks, full 40° turn	kg	7875	7661	7451
	lb	17,361	16,890	16,427
Operating weight	kg	15 743	15 764	15 786
	lb	34,707	34,754	34,802

		Construction Forks – Fusion	
Fork tine length	mm	1524	1829
	ft/in	5'0"	6'0"
Ground to top of tine clearance	mm	3693	3693
	ft/in	12'1"	12'1"
Reach with lift arms horizontal and forks level	mm	1675	1675
	ft/in	5'6"	5'6"
Overall length	mm	8366	8671
	ft/in	27'5"	28'5"
Static tipping load with level arms and forks, straight	kg	8405	7922
	lb	18,530	17,465
Static tipping load with level arms and forks, full 40° turn	kg	7136	6762
	lb	15,732	14,908
Operating weight	kg	16 266	16 311
	lb	35,860	35,960

\*Meets Tier 4 Final/Stage IV/Japan 2014 (Tier 4 Final) emission standards.

NOTE: Dimensions listed are for a machine configured with attachment, counterweights, additional guarding, 80 kg (176 lb) operator, and Michelin 20.5 R25 (L-3) XHA2 tires.

# Wheel Loaders Integrated Toolcarriers

- ## Performance Data
- 938M\* Standard Lift
  - Material Handling Arm

Handling Arm Position		Material Handling Arm – Fusion		
		Retracted	Mid-position	Extended
Operating load	kg	2638	2241	1948
	lb	<b>5815</b>	<b>4939</b>	<b>4293</b>
Static tipping load, straight	kg	6053	5142	4470
	lb	<b>13,345</b>	<b>11,336</b>	<b>9855</b>
Static tipping load, full 40° turn	kg	5275	4481	3895
	lb	<b>11,629</b>	<b>9879</b>	<b>8587</b>
Operating weight	kg	15 799	15 799	15 799
	lb	<b>34,831</b>	<b>34,831</b>	<b>34,831</b>

\*Meets Tier 4 Final/Stage IV/Japan 2014 (Tier 4 Final) emission standards.

**NOTE:** Dimensions listed are for a machine configured with attachment, counterweights, additional guarding, 80 kg (**176 lb**) operator, and Michelin 20.5 R25 (L-3) XHA2 tires.

Performance Data  
 ● 938M\* High Lift  
 ● Pallet Forks ● Construction Forks

Wheel Loaders  
 Integrated Toolcarriers

		Pallet Forks – Fusion		
Fork tine length	mm	1220	1370	1524
	ft/in	4'0"	4'6"	5'0"
Ground to top of tine clearance	mm	4339	4339	4339
	ft/in	14'3"	14'3"	14'3"
Reach with lift arms horizontal and forks level	mm	1714	1714	1714
	ft/in	5'7"	5'7"	5'7"
Overall length	mm	8695	8845	8999
	ft/in	28'6"	29'0"	29'6"
Static tipping load with level arms and forks, straight	kg	6947	6872	6618
	lb	15,315	15,150	14,590
Static tipping load with level arms and forks, full 40° turn	kg	5886	5742	5600
	lb	12,976	12,659	12,346
Operating weight	kg	15 830	15 851	15 873
	lb	34,899	34,945	34,994

		Pallet Forks – ISO		
Fork tine length	mm	1220	1370	1524
	ft/in	4'0"	4'6"	5'0"
Ground to top of tine clearance	mm	4336	4336	4336
	ft/in	14'3"	14'3"	14'3"
Reach with lift arms horizontal and forks level	mm	2241	2241	2241
	ft/in	7'4"	7'4"	7'4"
Overall length	mm	8717	8867	9021
	ft/in	28'7"	29'1"	29'7"
Static tipping load with level arms and forks, straight	kg	6963	6799	6636
	lb	15,351	14,989	14,630
Static tipping load with level arms and forks, full 40° turn	kg	5913	5771	5630
	lb	13,036	12,723	12,412
Operating weight	kg	15 641	15 663	15 684
	lb	34,482	34,531	34,577

		Construction Forks – Fusion	
Fork tine length	mm	1524	1829
	ft/in	5'0"	6'0"
Ground to top of tine clearance	mm	4274	4274
	ft/in	14'0"	14'0"
Reach with lift arms horizontal and forks level	mm	2282	2282
	ft/in	7'6"	7'6"
Overall length	mm	9103	9408
	ft/in	29'10"	30'10"
Static tipping load with level arms and forks, straight	kg	6295	6004
	lb	13,878	13,237
Static tipping load with level arms and forks, full 40° turn	kg	5298	5046
	lb	11,680	11,125
Operating weight	kg	16 164	16 209
	lb	35,635	35,735

\*Meets Tier 4 Final/Stage IV/Japan 2014 (Tier 4 Final) emission standards.

NOTE: Dimensions listed are for a machine configured with attachment, counterweights, additional guarding, 80 kg (176 lb) operator, and Michelin 20.5 R25 (L-3) XHA2 tires.

# Wheel Loaders Integrated Toolcarriers

- ## Performance Data
- 938M\* High Lift
  - Material Handling Arm

Handling Arm Position		Material Handling Arm – Fusion		
		Retracted	Mid-position	Extended
Operating load	kg	2092	1810	1595
	lb	<b>4612</b>	<b>3989</b>	<b>3515</b>
Static tipping load, straight	kg	4831	4179	3682
	lb	<b>10,651</b>	<b>9213</b>	<b>8117</b>
Static tipping load, full 40° turn	kg	4184	3619	3189
	lb	<b>9224</b>	<b>7979</b>	<b>7031</b>
Operating weight	kg	15 697	15 697	15 697
	lb	<b>34,606</b>	<b>34,606</b>	<b>34,606</b>

\*Meets Tier 4 Final/Stage IV/Japan 2014 (Tier 4 Final) emission standards.

**NOTE:** Dimensions listed are for a machine configured with Fusion attachment, counterweights, additional guarding, 80 kg (176 lb) operator, and Michelin 20.5 R25 (L3) XHA2 tires.

Bucket Type		General Purpose			Light Material	
		Pin On			Pin On	
Rated bucket capacity	m <sup>3</sup>	1.7	1.9	2.1	3.5	4.2
	yd <sup>3</sup>	2.2	2.5	2.7	4.6	5.5
Struck capacity	m <sup>3</sup>	1.3	1.7	1.9	3.3	4.0
	yd <sup>3</sup>	1.7	2.2	2.5	4.3	5.2
Bucket width	mm	2550	2550	2550	2750	2750
	ft/in	8'4"	8'4"	8'4"	9'0"	9'0"
Nominal material density 100 percent fill factor	kg/m <sup>3</sup>	2305	2043	1835	1028	827
	lb/yd <sup>3</sup>	3937	3424	3147	1724	1392
Dump clearance at full lift and 45° discharge	mm	2915	2857	2801	2575	2455
	ft/in	9'6"	9'4"	9'2"	8'5"	8'0"
Reach at full lift and 45° discharge	mm	882	950	990	1094	1214
	ft/in	2'10"	3'1"	3'2"	3'7"	3'11"
Reach at 45° discharge and 2130 mm (7'0") clearance	mm	1440	1480	1492	1463	1499
	ft/in	4'8"	4'10"	4'10"	4'9"	4'11"
Reach with lift arms horizontal and bucket level	mm	2142	2231	2303	2556	2726
	ft/in	7'0"	7'3"	7'6"	8'4"	8'11"
Digging depth	mm	100	100	100	100	100
	in	3.9	3.9	3.9	3.9	3.9
Overall length	mm	7284	7374	7446	7699	7869
	ft/in	23'10"	24'2"	24'5"	25'3"	25'9"
Overall height with bucket at full raise	mm	5002	4997	5068	5229	5390
	ft/in	16'4"	16'4"	16'7"	17'1"	17'8"
Loader clearance radius with bucket in carry position	mm	5297	5903	5925	6094	6148
	ft/in	17'4"	19'4"	19'5"	19'11"	20'2"
Tipping load — straight (ISO 14397-1)*	kg	9153	9053	8990	8442	8172
	lb	20,179	19,958	19,818	18,612	18,016
Tipping load — straight (rigid tire)**	kg	9535	9430	9364	8794	8513
	lb	21,020	20,789	20,644	19,387	18,767
Tipping load — full turn (ISO 14397-1)*	kg	7858	7765	7708	7194	6945
	lb	17,324	17,118	16,992	15,858	15,310
Tipping load — full turn (rigid tire)**	kg	8360	8260	8199	7653	7388
	lb	18,430	18,211	18,076	16,871	16,288
Breakout force	kg	12 273	10 342	9645	7626	6660
	lbf	27,056	22,801	21,264	16,812	14,682
Operating weight	kg	11 966	12 019	12 038	12 418	12 555
	lb	26,380	26,498	26,539	27,376	27,679

\*Full compliance to ISO 14397-1 (2007) Sections 1 thru 6, which requires 2% verification between calculation and testing.

\*\*Compliance to ISO 14397-1 (2007) Sections 1 thru 5.

**NOTE:** Dimensions listed are for a 924K configured with general purpose buckets, bolt-on cutting edges, optional counterweights, 80 kg (176 lb) operator, and Michelin 20.5 R25 (L-3) XHA2 tires at a pressure of 4.14 bar (60 psi) in the front tires and 2.76 bar (40 psi) in the rear tires.

Bucket Type		General Purpose			Light Material		ISO 23727	
		Fusion			Fusion			
Rated bucket capacity	m <sup>3</sup>	1.9	2.1	2.3	3.5	4.2	2.1	2.3
	yd <sup>3</sup>	<b>2.5</b>	<b>2.7</b>	<b>3.0</b>	<b>4.6</b>	<b>5.5</b>	<b>2.7</b>	<b>3.0</b>
Struck capacity	m <sup>3</sup>	1.7	1.9	2.1	3.3	4.0	2.0	2.2
	yd <sup>3</sup>	<b>2.2</b>	<b>2.5</b>	<b>2.7</b>	<b>4.3</b>	<b>5.2</b>	<b>2.6</b>	<b>2.9</b>
Bucket width	mm	2550	2550	2550	2750	2750	2550	2550
	ft/in	<b>8'4"</b>	<b>8'4"</b>	<b>8'4"</b>	<b>9'0"</b>	<b>9'0"</b>	<b>8'4"</b>	<b>8'4"</b>
Nominal material density 100 percent fill factor	kg/m <sup>3</sup>	1948	1744	1576	977	785	1676	1515
	lb/yd <sup>3</sup>	<b>3263</b>	<b>2990</b>	<b>2664</b>	<b>1638</b>	<b>1321</b>	<b>2874</b>	<b>2560</b>
Dump clearance at full lift and 45° discharge	mm	2830	2773	2725	2545	2425	2693	2643
	ft/in	<b>9'3"</b>	<b>9'1"</b>	<b>8'11"</b>	<b>8'4"</b>	<b>7'11"</b>	<b>8'10"</b>	<b>8'8"</b>
Reach at full lift and 45° discharge	mm	982	1022	1059	1124	1244	1126	1162
	ft/in	<b>3'2"</b>	<b>3'4"</b>	<b>3'5"</b>	<b>3'8"</b>	<b>4'0"</b>	<b>3'8"</b>	<b>3'9"</b>
Reach at 45° discharge and 2130 mm (7'0") clearance	mm	1499	1509	1520	1473	1506	1568	1575
	ft/in	<b>4'11"</b>	<b>4'11"</b>	<b>4'11"</b>	<b>4'9"</b>	<b>4'11"</b>	<b>5'1"</b>	<b>5'1"</b>
Reach with lift arms horizontal and bucket level	mm	2273	2345	2408	2598	2768	2476	2539
	ft/in	<b>7'5"</b>	<b>7'8"</b>	<b>7'10"</b>	<b>8'6"</b>	<b>9'0"</b>	<b>8'1"</b>	<b>8'3"</b>
Digging depth	mm	100	100	100	100	100	93	93
	in	<b>3.9</b>	<b>3.9</b>	<b>3.9</b>	<b>3.9</b>	<b>3.9</b>	<b>3.7</b>	<b>3.7</b>
Overall length	mm	7416	7488	7551	7741	7911	7613	7676
	ft/in	<b>24'3"</b>	<b>24'6"</b>	<b>24'9"</b>	<b>25'4"</b>	<b>25'11"</b>	<b>24'11"</b>	<b>25'2"</b>
Overall height with bucket at full raise	mm	5022	5093	5151	5254	5417	5182	5240
	ft/in	<b>16'5"</b>	<b>16'8"</b>	<b>16'10"</b>	<b>17'2"</b>	<b>17'9"</b>	<b>17'0"</b>	<b>17'2"</b>
Loader clearance radius with bucket in carry position	mm	5916	5938	5957	6107	6163	5959	5980
	ft/in	<b>19'4"</b>	<b>19'5"</b>	<b>19'6"</b>	<b>20'0"</b>	<b>20'2"</b>	<b>19'6"</b>	<b>19'7"</b>
Tipping load — straight (ISO 14397-1)*	kg	8667	8583	8503	8064	7799	8252	8174
	lb	<b>19,107</b>	<b>18,921</b>	<b>18,745</b>	<b>17,777</b>	<b>17,193</b>	<b>18,192</b>	<b>18,019</b>
Tipping load — straight (rigid tire)**	kg	9028	8940	8857	8400	8124	8596	8514
	lb	<b>19,903</b>	<b>19,709</b>	<b>19,526</b>	<b>18,518</b>	<b>17,909</b>	<b>18,950</b>	<b>18,770</b>
Tipping load — full turn (ISO 14397-1)*	kg	7401	7323	7250	6836	6593	7040	6968
	lb	<b>16,317</b>	<b>16,145</b>	<b>15,983</b>	<b>15,071</b>	<b>14,534</b>	<b>15,521</b>	<b>15,362</b>
Tipping load — full turn (rigid tire)**	kg	7874	7791	7713	7273	7013	7490	7413
	lb	<b>17,358</b>	<b>17,175</b>	<b>17,003</b>	<b>16,033</b>	<b>15,461</b>	<b>16,512</b>	<b>16,343</b>
Breakout force	kg	9893	9238	8725	7349	6433	8174	7756
	lbf	<b>21,811</b>	<b>20,365</b>	<b>19,235</b>	<b>16,200</b>	<b>14,181</b>	<b>18,020</b>	<b>17,098</b>
Operating weight	kg	12 361	12 405	12 443	12 768	12 908	12 352	12 390
	lb	<b>27,250</b>	<b>27,348</b>	<b>27,431</b>	<b>28,148</b>	<b>28,456</b>	<b>27,231</b>	<b>27,315</b>

\*Full compliance to ISO 14397-1 (2007) Sections 1 thru 6, which requires 2% verification between calculation and testing.

\*\*Compliance to ISO 14397-1 (2007) Sections 1 thru 5.

**NOTE:** Dimensions listed are for a 924K configured with general purpose buckets, bolt-on cutting edges, optional counterweights, 80 kg (176 lb) operator, and Michelin 20.5 R25 (L-3) XHA2 tires at a pressure of 4.14 bar (60 psi) in the front tires and 2.76 bar (40 psi) in the rear tires.

● 924K Standard Lift Pin On or Hook On Bucket

Performance Data

Wheel Loaders  
Integrated Toolcarriers

	Change in		Change in Tipping	
	Operating Weight		Load – Full Turn	
	kg	lb	kg	lb
Without optional counterweight . . . . .	- 320	- 705	- 521	- 1148
Without cab (semi-cab option) . . . . .	- 100	- 220	- 116	- 255
With guard, driveshaft . . . . .	+ 44	+ 97	+ 12	+ 26
With ride control . . . . .	+ 49	+ 108	+ 27	+ 59
With roading fenders . . . . .	+ 18	+ 39	+ 25	+ 55
With guards, front lights . . . . .	+ 11	+ 24	+ 2	+ 4
With guard, hitch . . . . .	+ 54	+ 119	+ 37	+ 81
With guard, front window . . . . .	+ 34	+ 74	+ 19	+ 41
With guards, steering cylinders . . . . .	+ 14	+ 30	+ 10	+ 22
With guard, power train lower . . . . .	+ 77	+ 169	+ 72	+ 158
With secondary steering . . . . .	+ 69	+ 152	+ 76	+ 167
With guard, crankcase . . . . .	+ 19	+ 41	+ 25	+ 55
With guards, power train side . . . . .	+ 11	+ 24	+ 9	+ 19
With tool box . . . . .	+ 44	+ 97	+ 26	+ 57
With cold start package . . . . .	+ 54	+ 119	+ 77	+ 169
With counterweight, logger . . . . .	+ 299	+ 658	+ 417	+ 919
20.5-25 12PR . . . . .	- 282	- 621	- 164	- 361
17.5 R25 (L-2) . . . . .	- 40	- 88	- 187	- 412



# Wheel Loaders Integrated Toolcarriers

## Performance Data

- 924K Standard Lift Fusion
- Pallet Forks ● Construction Forks
- Material Handling Arm

		Pallet Forks	Construction Forks
Fork tine length	mm	1220	1524
	ft/in	4'0"	5'0"
Load center	mm	610	762
	ft/in	2'0"	2'6"
Overall length	mm	7840	8263
	ft/in	25'8"	27'1"
Ground reach	mm	891	1009
	ft/in	2'11"	3'3"
Digging depth	mm	47	120
	in	1.9	4.7
Level arm reach	mm	1522	1580
	ft/in	4'11"	5'2"
Full lift reach	mm	724	782
	ft/in	2'4"	2'6"
Level arm clearance	mm	1761	1698
	ft/in	5'9"	5'6"
Full lift clearance	mm	3639	3575
	ft/in	11'11"	11'8"
Overall height	mm	4621	4880
	ft/in	15'1"	16'0"
Tipping load — straight (ISO 14397-1)*	kg	6615	5911
	lb	<b>14,578</b>	<b>13,028</b>
Tipping load — full turn (ISO 14397-1)*	kg	5670	5036
	lb	<b>12,495</b>	<b>11,099</b>
Operating weight	kg	12 070	12 404
	lb	<b>26,601</b>	<b>27,338</b>
Rated load (% of full turn tip): 50% of tip (SAE J1197)**	kg	2835	2518
	lb	<b>6247</b>	<b>5549</b>
Rated load (% of full turn tip): 60% of tip — rough terrain (EN474-3)**	kg	3402	3022
	lb	<b>7497</b>	<b>6659</b>
Rated load (% of full turn tip): 80% of tip — firm and level (EN474-3)**	kg	4536	4029
	lb	<b>9996</b>	<b>8879</b>

\*Full compliance to ISO 14397-1 (2007) Sections 1 thru 6, which requires 2% verification between calculation and testing.

\*\*Full compliance to EN474-3 and SAE J1197.

**NOTE:** Dimensions listed are for a machine configured with Fusion forks, optional counterweights, 80 kg (176 lb) operator, and Michelin 20.5 R25 (L-3) XHA2 tires.

Handling Arm Position		Material Handling Arm		
		Retracted	Mid-position	Extended
Rated load (50% of full turn tip* SAE J1197)	kg	1853	1569	1361
	lb	<b>4085</b>	<b>3459</b>	<b>2999</b>
Operating weight	kg	11 926	11 926	11 926
	lb	<b>26,292</b>	<b>26,292</b>	<b>26,292</b>

\*Full compliance to EN474-3 and SAE J1197.

Bucket Type		General Purpose			Light Material		High Lift Delta
		Pin On			Pin On		
Rated bucket capacity	m <sup>3</sup>	2.1	2.3	2.5	4.2	5.0	—
	yd <sup>3</sup>	<b>2.7</b>	<b>3.0</b>	<b>3.3</b>	<b>5.5</b>	<b>6.5</b>	—
Struck capacity	m <sup>3</sup>	1.9	2.1	2.3	4.0	4.8	—
	yd <sup>3</sup>	<b>2.5</b>	<b>2.7</b>	<b>3.0</b>	<b>5.2</b>	<b>6.3</b>	—
Bucket width	mm	2550	2550	2550	2750	2750	—
	ft/in	<b>8'4"</b>	<b>8'4"</b>	<b>8'4"</b>	<b>9'0"</b>	<b>9'0"</b>	—
Nominal material density 100 percent fill factor	kg/m <sup>3</sup>	2018	1821	1649	915	765	—
	lb/yd <sup>3</sup>	<b>3461</b>	<b>3077</b>	<b>2754</b>	<b>1541</b>	<b>1298</b>	—
Dump clearance at full lift and 45° discharge	mm	2855	2807	2761	2509	2509	+593
	ft/in	<b>9'4"</b>	<b>9'2"</b>	<b>9'0"</b>	<b>8'2"</b>	<b>8'2"</b>	<b>+1'11"</b>
Reach at full lift and 45° discharge	mm	1033	1070	1109	1257	1257	+320
	ft/in	<b>3'4"</b>	<b>3'6"</b>	<b>3'7"</b>	<b>4'1"</b>	<b>4'1"</b>	<b>+1'0"</b>
Reach at 45° discharge and 2130 mm (7'0") clearance	mm	1560	1573	1587	1579	1579	+717
	ft/in	<b>5'1"</b>	<b>5'1"</b>	<b>5'2"</b>	<b>5'2"</b>	<b>5'2"</b>	<b>+2'4"</b>
Reach with lift arms horizontal and bucket level	mm	2350	2413	2475	2773	2773	+653
	ft/in	<b>7'8"</b>	<b>7'11"</b>	<b>8'1"</b>	<b>9'1"</b>	<b>9'1"</b>	<b>+2'1"</b>
Digging depth	mm	100	100	100	100	100	+35
	in	<b>3.9</b>	<b>3.9</b>	<b>3.9</b>	<b>3.9</b>	<b>3.9</b>	<b>+1.4</b>
Overall length	mm	7488	7651	7613	7911	7911	+794
	ft/in	<b>24'6"</b>	<b>24'9"</b>	<b>24'11"</b>	<b>25'11"</b>	<b>25'11"</b>	<b>+2'7"</b>
Overall height with bucket at full raise	mm	5122	5180	5239	5445	5725	+593
	ft/in	<b>16'9"</b>	<b>16'11"</b>	<b>17'2"</b>	<b>17'10"</b>	<b>18'9"</b>	<b>+1'11"</b>
Loader clearance radius with bucket in carry position	mm	5933	5951	5970	6152	6152	+384
	ft/in	<b>19'5"</b>	<b>19'6"</b>	<b>19'7"</b>	<b>20'2"</b>	<b>20'2"</b>	<b>+1'3"</b>
Tipping load — straight (ISO 14397-1)*	kg	9908	9798	9661	9059	9028	-2723
	lb	<b>21,843</b>	<b>21,601</b>	<b>21,299</b>	<b>19,971</b>	<b>19,902</b>	<b>-6001</b>
Tipping load — straight (rigid tire)**	kg	10 321	10 206	10 064	9436	9404	-2836
	lb	<b>22,753</b>	<b>22,501</b>	<b>22,187</b>	<b>20,803</b>	<b>20,731</b>	<b>-6251</b>
Tipping load — full turn (ISO 14397-1)*	kg	8477	8375	8246	7688	7655	-2386
	lb	<b>18,688</b>	<b>18,463</b>	<b>18,179</b>	<b>16,948</b>	<b>16,875</b>	<b>-5259</b>
Tipping load — full turn (rigid tire)**	kg	9018	8909	8772	8178	8143	-2539
	lb	<b>19,881</b>	<b>19,641</b>	<b>19,339</b>	<b>18,029</b>	<b>17,952</b>	<b>-5595</b>
Breakout force	kg	12 891	12 158	11 488	9020	8969	-299
	lbf	<b>28,419</b>	<b>26,803</b>	<b>25,326</b>	<b>19,885</b>	<b>19,772</b>	<b>-658</b>
Operating weight	kg	13 135	13 198	13 297	13 651	13 721	+247
	lb	<b>28,956</b>	<b>29,096</b>	<b>29,314</b>	<b>30,096</b>	<b>30,250</b>	<b>+544</b>

\*Full compliance to ISO 14397-1 (2007) Sections 1 thru 6, which requires 2% verification between calculation and testing.

\*\*Compliance to ISO 14397-1 (2007) Sections 1 thru 5.

**NOTE:** Dimensions listed are for a 930K configured with general purpose buckets, bolt-on cutting edges, optional counterweights, 80 kg (176 lb) operator, and Michelin 20.5 R25 (L-3) XHA2 tires at a pressure of 4.14 bar (60 psi) in the front tires and 2.76 bar (40 psi) in the rear tires.

Bucket Type		General Purpose					Light Material		High Lift Delta
		Fusion		ISO 23727			Fusion		
Rated bucket capacity	m <sup>3</sup>	2.1	2.3	2.5	2.3	2.5	4.2	5.0	—
	yd <sup>3</sup>	<b>2.7</b>	<b>3.0</b>	<b>3.3</b>	<b>3.0</b>	<b>3.3</b>	<b>5.5</b>	<b>6.5</b>	—
Struck capacity	m <sup>3</sup>	1.9	2.1	2.3	2.2	2.4	4.0	4.8	—
	yd <sup>3</sup>	<b>2.5</b>	<b>2.7</b>	<b>3.0</b>	<b>2.9</b>	<b>3.1</b>	<b>5.2</b>	<b>6.3</b>	—
Bucket width	mm	2550	2550	2550	2550	2750	2750	2750	—
	ft/in	<b>8'4"</b>	<b>8'4"</b>	<b>8'4"</b>	<b>8'4"</b>	<b>9'0"</b>	<b>9'0"</b>	<b>9'0"</b>	—
Nominal material density 100 percent fill factor	kg/m <sup>3</sup>	1925	1741	1579	1674	1521	872	730	—
	lb/yd <sup>3</sup>	<b>3300</b>	<b>2942</b>	<b>2637</b>	<b>2830</b>	<b>2541</b>	<b>1468</b>	<b>1237</b>	—
Dump clearance at full lift and 45° discharge	mm	2828	2779	2733	2698	2698	2479	2479	+593
	ft/in	<b>9'3"</b>	<b>9'1"</b>	<b>8'11"</b>	<b>8'10"</b>	<b>8'10"</b>	<b>8'1"</b>	<b>8'1"</b>	<b>+1'11"</b>
Reach at full lift and 45° discharge	mm	1064	1102	1140	1205	1205	1286	1286	+320
	ft/in	<b>3'5"</b>	<b>3'7"</b>	<b>3'8"</b>	<b>3'11"</b>	<b>3'11"</b>	<b>4'2"</b>	<b>4'2"</b>	<b>+1'0"</b>
Reach at 45° discharge and 2130 mm (7'0") clearance	mm	1578	1590	1603	1648	1648	1588	1588	+717
	ft/in	<b>5'2"</b>	<b>5'2"</b>	<b>5'3"</b>	<b>5'4"</b>	<b>5'4"</b>	<b>5'2"</b>	<b>5'2"</b>	<b>+2'4"</b>
Reach with lift arms horizontal and bucket level	mm	2392	2455	2517	2586	2586	2815	2815	+653
	ft/in	<b>7'10"</b>	<b>8'0"</b>	<b>8'3"</b>	<b>8'5"</b>	<b>8'5"</b>	<b>9'2"</b>	<b>9'2"</b>	<b>+2'1"</b>
Digging depth	mm	100	100	100	93	93	100	100	+35
	in	<b>3.9</b>	<b>3.9</b>	<b>3.9</b>	<b>3.7</b>	<b>3.7</b>	<b>3.9</b>	<b>3.9</b>	<b>+1.4</b>
Overall length	mm	7530	7593	7655	7718	7718	7953	7953	+794
	ft/in	<b>24'8"</b>	<b>24'10"</b>	<b>25'1"</b>	<b>25'3"</b>	<b>25'3"</b>	<b>26'1"</b>	<b>26'1"</b>	<b>+2'7"</b>
Overall height with bucket at full raise	mm	5147	5205	5264	5294	5294	5471	5752	+593
	ft/in	<b>16'10"</b>	<b>17'0"</b>	<b>17'3"</b>	<b>17'4"</b>	<b>17'4"</b>	<b>17'11"</b>	<b>18'10"</b>	<b>+1'11"</b>
Loader clearance radius with bucket in carry position	mm	5945	5964	5983	5984	6075	6166	6166	+384
	ft/in	<b>19'6"</b>	<b>19'6"</b>	<b>19'7"</b>	<b>19'7"</b>	<b>19'11"</b>	<b>20'2"</b>	<b>20'2"</b>	<b>+1'3"</b>
Tipping load — straight (ISO 14397-1)*	kg	9490	9406	9288	9049	8952	8675	8646	-2723
	lb	<b>20,922</b>	<b>20,737</b>	<b>20,476</b>	<b>19,949</b>	<b>19,736</b>	<b>19,124</b>	<b>19,060</b>	<b>-6001</b>
Tipping load — straight (rigid tire)**	kg	9886	9798	9675	9426	9325	9036	9006	-2836
	lb	<b>21,794</b>	<b>21,601</b>	<b>21,329</b>	<b>20,780</b>	<b>20,558</b>	<b>19,921</b>	<b>19,854</b>	<b>-6251</b>
Tipping load — full turn (ISO 14397-1)*	kg	8083	8007	7896	7702	7607	7326	7295	-2386
	lb	<b>17,820</b>	<b>17,651</b>	<b>17,407</b>	<b>16,979</b>	<b>16,771</b>	<b>16,151</b>	<b>16,083</b>	<b>-5259</b>
Tipping load — full turn (rigid tire)**	kg	8599	8518	8400	8193	8093	7794	7761	-2539
	lb	<b>18,958</b>	<b>18,778</b>	<b>18,518</b>	<b>18,063</b>	<b>17,841</b>	<b>17,182</b>	<b>17,110</b>	<b>-5595</b>
Breakout force	kg	12 366	11 693	11 076	10 432	10 375	8730	8682	-299
	lbf	<b>27,262</b>	<b>25,779</b>	<b>24,417</b>	<b>22,998</b>	<b>22,873</b>	<b>19,246</b>	<b>19,139</b>	<b>-658</b>
Operating weight	kg	13 501	13 539	13 621	13 487	13 590	14 004	14 069	+247
	lb	<b>29,765</b>	<b>29,848</b>	<b>30,030</b>	<b>29,732</b>	<b>29,959</b>	<b>30,873</b>	<b>31,017</b>	<b>+544</b>

\*Full compliance to ISO 14397-1 (2007) Sections 1 thru 6, which requires 2% verification between calculation and testing.

\*\*Compliance to ISO 14397-1 (2007) Sections 1 thru 5.

**NOTE:** Dimensions listed are for a 930K configured with general purpose buckets, bolt-on cutting edges, optional counterweights, 80 kg (176 lb) operator, and Michelin 20.5 R25 (L-3) XHA2 tires at a pressure of 4.14 bar (60 psi) in the front tires and 2.76 bar (40 psi) in the rear tires.

● 930K Standard Lift Pin On or Hook On Bucket

Performance Data

Wheel Loaders  
Integrated Toolcarriers

	Change in Operating Weight		Change in Tipping Load – Full Turn with 2.1 m <sup>3</sup> (2.75 yd <sup>3</sup> ) Fusion Bucket	
	kg	lb	kg	lb
Without optional counterweight . . . . .	- 320	- 705	- 509	- 1121
Without cab (semi-cab option) . . . . .	- 100	- 220	- 112	- 246
With guard, driveshaft . . . . .	+ 44	+ 97	+ 12	+ 26
With ride control . . . . .	+ 49	+ 108	+ 27	+ 59
With roading fenders . . . . .	+ 18	+ 39	+ 24	+ 52
With guards, front lights . . . . .	+ 11	+ 24	+ 2	+ 4
With guard, hitch . . . . .	+ 54	+ 119	+ 36	+ 79
With guard, front window . . . . .	+ 34	+ 74	+ 19	+ 41
With guards, steering cylinders . . . . .	+ 14	+ 30	+ 10	+ 22
With guard, power train lower . . . . .	+ 77	+ 169	+ 70	+ 154
With secondary steering . . . . .	+ 69	+ 152	+ 74	+ 163
With guard, crankcase . . . . .	+ 19	+ 41	+ 25	+ 55
With guards, power train side . . . . .	+ 11	+ 24	+ 9	+ 19
With tool box . . . . .	+ 44	+ 97	+ 25	+ 55
With guard, rear waste gate . . . . .	+ 263	+ 580	+ 466	+ 1027
With cold start package . . . . .	+ 54	+ 119	+ 75	+ 165
With counterweight, logger . . . . .	+ 299	+ 658	+ 415	+ 914
20.5-25 16PR . . . . .	- 254	- 559	- 144	- 316
20.5R25 (L-5) . . . . .	+ 678	+ 1494	+ 384	+ 846

# Wheel Loaders Integrated Toolcarriers

## Performance Data

- 930K Standard Lift Fusion
- Pallet Forks ● Construction Forks
- Material Handling Arm

		Pallet Forks	Construction Forks
Fork tine length	mm	1220	1524
	ft/in	4'0"	5'0"
Load center	mm	610	762
	ft/in	2'0"	2'6"
Overall length	mm	7882	8305
	ft/in	25'10"	27'2"
Ground reach	mm	926	1045
	ft/in	3'0"	3'5"
Digging depth	mm	47	120
	in	1.9	4.7
Level arm reach	mm	1569	1627
	ft/in	5'1"	5'4"
Full lift reach	mm	767	825
	ft/in	2'6"	2'8"
Level arm clearance	mm	1792	1729
	ft/in	5'10"	5'8"
Full lift clearance	mm	3693	3630
	ft/in	12'1"	11'10"
Overall height	mm	4676	4935
	ft/in	15'4"	16'2"
Tipping load — straight (ISO 14397-1)*	kg	7351	6604
	lb	16,201	14,555
Tipping load — full turn (ISO 14397-1)*	kg	6287	5617
	lb	13,856	12,379
Operating weight	kg	13 166	13 501
	lb	29,017	29,756
Rated load (% of full turn tip): 50% of tip (SAE J1197)**	kg	3144	2808
	lb	6929	6188
Rated load (% of full turn tip): 60% of tip — rough terrain (EN474-3)**	kg	3772	3370
	lb	8313	7427
Rated load (% of full turn tip): 80% of tip — firm and level (EN474-3)**	kg	5030	4494
	lb	11,086	9904

\*Full compliance to ISO 14397-1 (2007) Sections 1 thru 6, which requires 2% verification between calculation and testing.

\*\*Full compliance to EN474-3 and SAE J1197.

**NOTE:** Dimensions listed are for a machine configured with Fusion forks, optional counterweights, 80 kg (176 lb) operator, and Michelin 20.5 R25 (L-3) XHA2 tires.

Handling Arm Position		Material Handling Arm		
		Retracted	Mid-position	Extended
Rated load (50% of full turn tip* SAE J1197)	kg	2061	1748	1518
	lb	4545	3855	3347
Operating weight	kg	13 061	13 061	13 061
	lb	28,795	28,795	28,795

\*Full compliance to EN474-3 and SAE J1197.

Bucket Type		General Purpose			Light Material		High Lift Delta
		Pin On			Pin On		
Rated bucket capacity	m <sup>3</sup>	2.5	2.7	2.9	4.2	5.0	-
	yd <sup>3</sup>	<b>3.3</b>	<b>3.5</b>	<b>3.8</b>	<b>5.5</b>	<b>6.5</b>	-
Struck capacity	m <sup>3</sup>	2.3	2.5	2.7	4.0	4.8	-
	yd <sup>3</sup>	<b>3.0</b>	<b>3.3</b>	<b>3.5</b>	<b>5.2</b>	<b>6.3</b>	-
Bucket width	mm	2750	2750	2750	2750	2750	-
	ft/in	<b>9'0"</b>	<b>9'0"</b>	<b>9'0"</b>	<b>9'0"</b>	<b>9'0"</b>	-
Nominal material density 100 percent fill factor	kg/m <sup>3</sup>	1940	1780	1644	1080	905	-
	lb/yd <sup>3</sup>	<b>3239</b>	<b>3027</b>	<b>2766</b>	<b>1818</b>	<b>1535</b>	-
Dump clearance at full lift and 45° discharge	mm	2869	2822	2786	2571	2571	+581
	ft/in	<b>9'4"</b>	<b>9'3"</b>	<b>9'1"</b>	<b>8'5"</b>	<b>8'5"</b>	<b>+1'10"</b>
Reach at full lift and 45° discharge	mm	1108	1146	1178	1294	1294	+267
	ft/in	<b>3'7"</b>	<b>3'9"</b>	<b>3'10"</b>	<b>4'2"</b>	<b>4'2"</b>	<b>+11"</b>
Reach at 45° discharge and 2130 mm (7'0") clearance	mm	1637	1652	1664	1654	1654	+666
	ft/in	<b>5'4"</b>	<b>5'5"</b>	<b>5'5"</b>	<b>5'5"</b>	<b>5'5"</b>	<b>+2'2"</b>
Reach with lift arms horizontal and bucket level	mm	2452	2514	2563	2812	2812	+607
	ft/in	<b>8'0"</b>	<b>8'2"</b>	<b>8'4"</b>	<b>9'2"</b>	<b>9'2"</b>	<b>+1'11"</b>
Digging depth	mm	100	100	100	100	100	+35
	in	<b>3.9</b>	<b>3.9</b>	<b>3.9</b>	<b>3.9</b>	<b>3.9</b>	<b>+1.4</b>
Overall length	mm	7604	7666	7715	7964	7964	+740
	ft/in	<b>24'11"</b>	<b>25'1"</b>	<b>25'3"</b>	<b>26'1"</b>	<b>26'1"</b>	<b>+2'5"</b>
Overall height with bucket at full raise	mm	5242	5301	5348	5507	5786	+581
	ft/in	<b>17'2"</b>	<b>17'4"</b>	<b>17'6"</b>	<b>18'0"</b>	<b>18'11"</b>	<b>+1'10"</b>
Loader clearance radius with bucket in carry position	mm	6117	6136	6150	6227	6227	+357
	ft/in	<b>20'0"</b>	<b>20'1"</b>	<b>20'2"</b>	<b>20'5"</b>	<b>20'5"</b>	<b>+1'2"</b>
Tipping load — straight (ISO 14397-1)*	kg	11 831	11 733	11 651	11 138	11 136	-3497
	lb	<b>26,074</b>	<b>25,860</b>	<b>25,679</b>	<b>24,547</b>	<b>24,544</b>	<b>-7708</b>
Tipping load — straight (rigid tire)**	kg	12 323	12 222	12 137	11 602	11 600	-3643
	lb	<b>27,160</b>	<b>26,937</b>	<b>26,749</b>	<b>25,570</b>	<b>25,567</b>	<b>-8029</b>
Tipping load — full turn (ISO 14397-1)*	kg	10 076	9986	9912	9440	9436	-3031
	lb	<b>22,206</b>	<b>22,010</b>	<b>21,845</b>	<b>20,806</b>	<b>20,796</b>	<b>-6680</b>
Tipping load — full turn (rigid tire)**	kg	10 719	10 624	10 544	10 043	10 038	-3224
	lb	<b>23,624</b>	<b>23,414</b>	<b>23,239</b>	<b>22,134</b>	<b>22,123</b>	<b>-7106</b>
Breakout force	kg	13 813	13 082	12 552	10 331	10 292	-502
	lbf	<b>30,442</b>	<b>28,833</b>	<b>27,665</b>	<b>22,768</b>	<b>22,684</b>	<b>-1106</b>
Operating weight	kg	15 465	15 510	15 547	15 811	15 858	-102
	lb	<b>34,085</b>	<b>34,184</b>	<b>34,264</b>	<b>34,848</b>	<b>34,951</b>	<b>-225</b>

\*Full compliance to ISO 14397-1 (2007) Sections 1 thru 6, which requires 2% verification between calculation and testing.

\*\*Compliance to ISO 14397-1 (2007) Sections 1 thru 5.

**NOTE:** Dimensions listed are for a 938K configured with general purpose buckets, bolt-on cutting edges, optional counterweights, 80 kg (176 lb) operator, and Michelin 20.5 R25 (L-3) XHA2 tires at a pressure of 4.48 bar (65 psi) in the front tires and 2.76 bar (40 psi) in the rear tires.

Bucket Type		General Purpose					Light Material		High Lift Delta
		Fusion		ISO 23727			Fusion		
Rated bucket capacity	m <sup>3</sup>	2.5	2.7	2.9	2.7	2.9	4.2	5.0	–
	yd <sup>3</sup>	<b>3.3</b>	<b>3.5</b>	<b>3.8</b>	<b>3.5</b>	<b>3.8</b>	<b>5.5</b>	<b>6.5</b>	–
Struck capacity	m <sup>3</sup>	2.3	2.5	2.7	2.6	2.7	4.0	4.8	–
	yd <sup>3</sup>	<b>3.0</b>	<b>3.3</b>	<b>3.5</b>	<b>3.4</b>	<b>3.5</b>	<b>5.2</b>	<b>6.3</b>	–
Bucket width	mm	2750	2750	2750	2750	2750	2750	2750	–
	ft/in	<b>9'0"</b>	<b>9'0"</b>	<b>9'0"</b>	<b>9'0"</b>	<b>9'0"</b>	<b>9'0"</b>	<b>9'0"</b>	–
Nominal material density 100 percent fill factor	kg/m <sup>3</sup>	1848	1695	1566	1644	1519	1029	861	–
	lb/yd <sup>3</sup>	<b>3086</b>	<b>2882</b>	<b>2634</b>	<b>2796</b>	<b>2556</b>	<b>1732</b>	<b>1461</b>	–
Dump clearance at full lift and 45° discharge	mm	2834	2787	2751	2712	2675	2534	2534	+581
	ft/in	<b>9'3"</b>	<b>9'1"</b>	<b>9'0"</b>	<b>8'10"</b>	<b>8'9"</b>	<b>8'3"</b>	<b>8'3"</b>	<b>+1'10"</b>
Reach at full lift and 45° discharge	mm	1146	1185	1216	1280	1311	1331	1331	+267
	ft/in	<b>3'9"</b>	<b>3'10"</b>	<b>3'11"</b>	<b>4'2"</b>	<b>4'3"</b>	<b>4'4"</b>	<b>4'4"</b>	<b>+11"</b>
Reach at 45° discharge and 2130 mm (7'0") clearance	mm	1658	1672	1684	1726	1735	1666	1666	+666
	ft/in	<b>5'5"</b>	<b>5'5"</b>	<b>5'6"</b>	<b>5'7"</b>	<b>5'8"</b>	<b>5'5"</b>	<b>5'5"</b>	<b>+2'2"</b>
Reach with lift arms horizontal and bucket level	mm	2504	2566	2615	2687	2736	2864	2864	+607
	ft/in	<b>8'2"</b>	<b>8'5"</b>	<b>8'6"</b>	<b>8'9"</b>	<b>8'11"</b>	<b>9'4"</b>	<b>9'4"</b>	<b>+1'11"</b>
Digging depth	mm	101	101	101	93	93	101	101	+35
	in	<b>4.0</b>	<b>4.0</b>	<b>4.0</b>	<b>3.7</b>	<b>3.7</b>	<b>4.0</b>	<b>4</b>	<b>+1.4</b>
Overall length	mm	7656	7718	7767	7833	7882	8016	8016	+740
	ft/in	<b>25'1"</b>	<b>25'3"</b>	<b>25'5"</b>	<b>25'8"</b>	<b>25'10"</b>	<b>26'3"</b>	<b>26'3"</b>	<b>+2'5"</b>
Overall height with bucket at full raise	mm	5273	5332	5379	5415	5462	5539	5820	+581
	ft/in	<b>17'3"</b>	<b>17'5"</b>	<b>17'7"</b>	<b>17'9"</b>	<b>17'11"</b>	<b>18'2"</b>	<b>19'1"</b>	<b>+1'10"</b>
Loader clearance radius with bucket in carry position	mm	6133	6152	6166	6169	6185	6244	6244	+357
	ft/in	<b>20'1"</b>	<b>20'2"</b>	<b>20'2"</b>	<b>20'2"</b>	<b>20'3"</b>	<b>20'5"</b>	<b>20'5"</b>	<b>+1'2"</b>
Tipping load — straight (ISO 14397-1)*	kg	11 314	11 218	11 139	10 763	10 690	10 659	10 628	–3497
	lb	<b>24,935</b>	<b>24,723</b>	<b>24,549</b>	<b>23,721</b>	<b>23,561</b>	<b>23,492</b>	<b>23,423</b>	<b>–7708</b>
Tipping load — straight (rigid tire)**	kg	11 785	11 685	11 603	11 211	11 136	11 103	11 070	–3643
	lb	<b>25,974</b>	<b>25,753</b>	<b>25,572</b>	<b>24,709</b>	<b>24,542</b>	<b>24,471</b>	<b>24,399</b>	<b>–8029</b>
Tipping load — full turn (ISO 14397-1)*	kg	9593	9505	9433	9121	9055	8994	8960	–3031
	lb	<b>21,142</b>	<b>20,948</b>	<b>20,790</b>	<b>20,103</b>	<b>19,957</b>	<b>19,822</b>	<b>19,747</b>	<b>–6680</b>
Tipping load — full turn (rigid tire)**	kg	10 205	10 112	10 035	9704	9633	9568	9532	–3224
	lb	<b>22,492</b>	<b>22,285</b>	<b>22,117</b>	<b>21,386</b>	<b>21,230</b>	<b>21,087</b>	<b>21,007</b>	<b>–7106</b>
Breakout force	kg	13 170	12 498	12 009	11 039	10 643	9942	9888	–502
	lbf	<b>29,027</b>	<b>27,546</b>	<b>26,467</b>	<b>24,330</b>	<b>23,456</b>	<b>21,912</b>	<b>21,792</b>	<b>–1106</b>
Operating weight	kg	15 892	15 936	15 972	15 831	15 865	16 222	16 299	–102
	lb	<b>35,025</b>	<b>35,122</b>	<b>35,202</b>	<b>34,892</b>	<b>34,967</b>	<b>35,752</b>	<b>35,923</b>	<b>–225</b>

\*Full compliance to ISO 14397-1 (2007) Sections 1 thru 6, which requires 2% verification between calculation and testing.

\*\*Compliance to ISO 14397-1 (2007) Sections 1 thru 5.

**NOTE:** Dimensions listed are for a 938K configured with general purpose buckets, bolt-on cutting edges, optional counterweights, 80 kg (176 lb) operator, and Michelin 20.5 R25 (L-3) XHA2 tires at a pressure of 4.48 bar (65 psi) in the front tires and 2.76 bar (40 psi) in the rear tires.

● 938K Standard Lift Pin On or Hook On Bucket

Performance Data

Wheel Loaders  
Integrated Toolcarriers

	Change in		Change in Tipping	
	Operating Weight		Load – Full Turn	
	kg	lb	with 2.5 m <sup>3</sup> (3.25 yd <sup>3</sup> ) Fusion Bucket	
	kg	lb	kg	lb
Without optional counterweight . . . . .	- 320	- 705	- 502	- 1106
Without cab (semi-cab option) . . . . .	- 100	- 220	- 113	- 249
With guard, driveshaft . . . . .	+ 45	+ 99	+ 12	+ 26
With ride control . . . . .	+ 49	+ 108	+ 27	+ 59
With roading fenders . . . . .	+ 18	+ 39	+ 24	+ 52
With guards, front lights . . . . .	+ 11	+ 24	+ 2	+ 4
With guard, hitch . . . . .	+ 54	+ 119	+ 36	+ 79
With guard, front window . . . . .	+ 34	+ 74	+ 19	+ 41
With guards, steering cylinders . . . . .	+ 14	+ 30	+ 10	+ 22
With guard, power train lower . . . . .	+ 70	+ 154	+ 63	+ 138
With secondary steering . . . . .	+ 69	+ 152	+ 74	+ 163
With guard, crankcase . . . . .	+ 11	+ 24	+ 14	+ 30
With guards, power train side . . . . .	+ 11	+ 24	+ 9	+ 19
With tool box . . . . .	+ 44	+ 97	+ 25	+ 55
With guard, rear waste gate . . . . .	+ 276	+ 608	+ 488	+ 1075
With cold start package . . . . .	+ 54	+ 119	+ 75	+ 165
With counterweight, logger . . . . .	+ 299	+ 658	+ 402	+ 886
20.5R25 (L5) . . . . .	+ 678	+ 1494	+ 381	+ 839
650/65 R25 . . . . .	+ 506	+ 115	+ 285	+ 628



# Wheel Loaders Integrated Toolcarriers

## Performance Data

- 938K Standard Lift Fusion
- Pallet Forks   ● Construction Forks

		Pallet Forks	Construction Forks
Fork tine length	mm	1220	1524
	ft/in	4'0"	5'0"
Load center	mm	610	762
	ft/in	2'0"	2'6"
Overall length	mm	7942	8366
	ft/in	26'0"	27'5"
Ground reach	mm	961	1081
	ft/in	3'1"	3'6"
Digging depth	mm	44	119
	in	1.7	4.7
Level arm reach	mm	1617	1675
	ft/in	5'3"	5'5"
Full lift reach	mm	814	872
	ft/in	2'8"	2'10"
Level arm clearance	mm	1830	1766
	ft/in	6'0"	5'9"
Full lift clearance	mm	3758	3693
	ft/in	12'3"	12'1"
Overall height	mm	4740	4998
	ft/in	15'6"	16'4"
Tipping load — straight (ISO 14397-1)*	kg	8891	8047
	lb	<b>19,601</b>	<b>17,741</b>
Tipping load — full turn (ISO 14397-1)*	kg	7580	6828
	lb	<b>16,711</b>	<b>15,053</b>
Operating weight	kg	15 396	15 730
	lb	<b>33,942</b>	<b>34,679</b>
Rated load (% of full turn tip): 50% of tip (SAE J1197)**	kg	3790	3414
	lb	<b>8356</b>	<b>7527</b>
Rated load (% of full turn tip): 60% of tip — rough terrain (EN474-3)**	kg	4548	4097
	lb	<b>10,027</b>	<b>9032</b>
Rated load (% of full turn tip): 80% of tip — firm and level (EN474-3)**	kg	6064	5462
	lb	<b>13,369</b>	<b>12,042</b>

\*Full compliance to ISO 14397-1 (2007) Sections 1 thru 6, which requires 2% verification between calculation and testing.

\*\*Full compliance to EN474-3 and SAE J1197.

**NOTE:** Dimensions listed are for a machine configured with Fusion forks, optional counterweights, 80 kg (176 lb) operator, and Michelin 20.5 R25 (L-3) XHA2 tires.

- Performance Data
- 938K Standard Lift Fusion
  - Material Handling Arm

## Wheel Loaders Integrated Toolcarriers

Handling Arm Position		Material Handling Arm – Fusion		
		Retracted	Mid-position	Extended
Operating load	kg	2528	2148	1871
	lb	<b>5573</b>	<b>4734</b>	<b>4125</b>
Static tipping load, straight	kg	5803	4930	4296
	lb	<b>12,793</b>	<b>10,869</b>	<b>9471</b>
Static tipping load, full 40° turn	kg	5056	4295	3742
	lb	<b>11,147</b>	<b>9469</b>	<b>8250</b>
Operating weight	kg	15 263	15 263	15 228
	lb	<b>33,649</b>	<b>33,649</b>	<b>33,571</b>

Bucket Type	General Purpose — Pin On							High Lift Delta
	Bucket Part Number	354-4849	354-4849	354-4849	354-4851	354-4851	354-4851	
Edge Type		Bolt-on Cutting Edges	Teeth & Segments	Tips	Bolt-on Cutting Edges	Teeth & Segments	Tips	
Capacity — rated	m <sup>3</sup>	2.70	2.70	2.50	2.90	2.90	2.70	—
	yd <sup>3</sup>	<b>3.53</b>	<b>3.53</b>	<b>3.27</b>	<b>3.79</b>	<b>3.79</b>	<b>3.53</b>	—
Capacity — 110%	m <sup>3</sup>	2.97	2.97	2.75	3.19	3.19	2.97	—
	yd <sup>3</sup>	<b>3.88</b>	<b>3.88</b>	<b>3.60</b>	<b>4.17</b>	<b>4.17</b>	<b>3.88</b>	—
Width	mm	2927	2994	2994	2927	2994	2994	—
	ft/in	<b>9'7"</b>	<b>9'9"</b>	<b>9'9"</b>	<b>9'7"</b>	<b>9'9"</b>	<b>9'9"</b>	—
Dump clearance at maximum lift and 45° discharge	mm	2975	2859	2859	2919	2802	2802	505
	ft/in	<b>9'9"</b>	<b>9'4"</b>	<b>9'4"</b>	<b>9'6"</b>	<b>9'2"</b>	<b>9'2"</b>	<b>1'7"</b>
Reach at maximum lift and 45° discharge	mm	1356	1469	1469	1395	1506	1506	36
	ft/in	<b>4'5"</b>	<b>4'9"</b>	<b>4'9"</b>	<b>4'6"</b>	<b>4'11"</b>	<b>4'11"</b>	<b>1"</b>
Reach at level lift arm and bucket level	mm	2562	2723	2723	2631	2792	2792	375
	ft/in	<b>8'4"</b>	<b>8'11"</b>	<b>8'11"</b>	<b>8'7"</b>	<b>9'1"</b>	<b>9'1"</b>	<b>1'2"</b>
Digging depth	mm	90	90	60	90	90	60	4
	in	<b>3.5</b>	<b>3.5</b>	<b>2.3</b>	<b>3.5</b>	<b>3.5</b>	<b>2.3</b>	<b>0</b>
Overall length	mm	8073	8246	8246	8142	8315	8315	583
	ft/in	<b>26'6"</b>	<b>27'1"</b>	<b>27'1"</b>	<b>26'9"</b>	<b>27'4"</b>	<b>27'4"</b>	<b>1'10"</b>
Overall height with bucket at maximum lift	mm	5392	5392	5392	5464	5464	5464	505
	ft/in	<b>17'9"</b>	<b>17'9"</b>	<b>17'9"</b>	<b>18'0"</b>	<b>18'0"</b>	<b>18'0"</b>	<b>1'7"</b>
Loader clearance circle with bucket at carry position	mm	13 689	13 856	13 856	13 729	13 897	13 897	393
	ft/in	<b>44'11"</b>	<b>45'6"</b>	<b>45'6"</b>	<b>45'1"</b>	<b>45'8"</b>	<b>45'8"</b>	<b>1'3"</b>
Static tipping load, straight (with tire deflection)*	kg	13 003	12 865	13 164	12 862	12 723	13 014	-1277
	lb	<b>28,660</b>	<b>28,355</b>	<b>29,014</b>	<b>28,349</b>	<b>28,041</b>	<b>28,684</b>	<b>-2815</b>
Static tipping load, straight (no tire deflection)*	kg	13 737	13 597	13 905	13 599	13 458	13 757	-1436
	lb	<b>30,276</b>	<b>29,969</b>	<b>30,646</b>	<b>29,973</b>	<b>29,662</b>	<b>30,322</b>	<b>-3166</b>
Static tipping load, articulated (with tire deflection)*	kg	11 227	11 089	11 369	11 091	10 952	11 225	-1184
	lb	<b>24,745</b>	<b>24,441</b>	<b>25,057</b>	<b>24,446</b>	<b>24,138</b>	<b>24,740</b>	<b>-2610</b>
Static tipping load, articulated (no tire deflection)*	kg	11 975	11 835	12 123	11 842	11 701	11 982	-1334
	lb	<b>26,393</b>	<b>26,085</b>	<b>26,719</b>	<b>26,101</b>	<b>25,790</b>	<b>26,408</b>	<b>-2941</b>
Breakout force	kN	202	200	221	190	188	207	-9
	lbf	<b>45,434</b>	<b>45,144</b>	<b>49,798</b>	<b>42,709</b>	<b>42,422</b>	<b>46,570</b>	<b>-20</b>
Operating weight*	kg	19 092	19 200	19 043	19 177	19 285	19 128	602
	lb	<b>42,079</b>	<b>42,317</b>	<b>41,971</b>	<b>42,265</b>	<b>42,503</b>	<b>42,157</b>	<b>1327</b>

\*Static tipping loads and operating weights shown are based on a machine configuration with Michelin 23.5R25 XHA2 L3 radial tires, full fluids, operator, cold start, roading fenders, Product Link, Manual Diff Lock/Open axles (front/rear), power train guard, secondary steering and sound suppression. (With Tire Deflection) Full compliance to ISO 14397-1 (2007) Sections 1 thru 6, which requires 2% verification between calculations and testing. (No Tire Deflection) Compliance to ISO 14397-1 (2007) Sections 1 thru 5.

**NOTE:** Machine and bucket availability varies by region. Consult your local dealer for availability.

Bucket Type	General Purpose — Pin On							High Lift Delta
	Bucket Part Number	352-5537	352-5537	352-5537	352-5538	352-5538	352-5538	
Edge Type		Bolt-on Cutting Edges	Teeth & Segments	Tips	Bolt-on Cutting Edges	Teeth & Segments	Tips	
Capacity — rated	m <sup>3</sup>	3.10	3.10	2.90	3.30	3.30	3.10	—
	yd <sup>3</sup>	<b>4.05</b>	<b>4.05</b>	<b>3.79</b>	<b>4.32</b>	<b>4.32</b>	<b>4.05</b>	—
Capacity — 110%	m <sup>3</sup>	3.41	3.41	3.19	3.63	3.63	3.41	—
	yd <sup>3</sup>	<b>4.46</b>	<b>4.46</b>	<b>4.17</b>	<b>4.75</b>	<b>4.75</b>	<b>4.46</b>	—
Width	mm	2927	2994	2994	2927	2994	2994	—
	ft/in	<b>9'7"</b>	<b>9'9"</b>	<b>9'9"</b>	<b>9'7"</b>	<b>9'9"</b>	<b>9'9"</b>	—
Dump clearance at maximum lift and 45° discharge	mm	2876	2758	2758	2838	2719	2719	505
	ft/in	<b>9'5"</b>	<b>9'0"</b>	<b>9'0"</b>	<b>9'3"</b>	<b>8'11"</b>	<b>8'11"</b>	<b>1'7"</b>
Reach at maximum lift and 45° discharge	mm	1429	1540	1540	1458	1568	1568	36
	ft/in	<b>4'8"</b>	<b>5'0"</b>	<b>5'0"</b>	<b>4'9"</b>	<b>5'1"</b>	<b>5'1"</b>	<b>1"</b>
Reach at level lift arm and bucket level	mm	2688	2849	2849	2737	2898	2898	375
	ft/in	<b>8'9"</b>	<b>9'4"</b>	<b>9'4"</b>	<b>8'11"</b>	<b>9'6"</b>	<b>9'6"</b>	<b>1'2"</b>
Digging depth	mm	90	90	60	90	90	60	4
	in	<b>3.5</b>	<b>3.5</b>	<b>2.3</b>	<b>3.5</b>	<b>3.5</b>	<b>2.3</b>	<b>0</b>
Overall length	mm	8199	8372	8372	8248	8421	8421	583
	ft/in	<b>26'11"</b>	<b>27'6"</b>	<b>27'6"</b>	<b>27'1"</b>	<b>27'8"</b>	<b>27'8"</b>	<b>1'10"</b>
Overall height with bucket at maximum lift	mm	5525	5525	5525	5571	5571	5571	505
	ft/in	<b>18'2"</b>	<b>18'2"</b>	<b>18'2"</b>	<b>18'4"</b>	<b>18'4"</b>	<b>18'4"</b>	<b>1'7"</b>
Loader clearance circle with bucket at carry position	mm	13 762	13 931	13 931	13 791	13 961	13 961	393
	ft/in	<b>45'2"</b>	<b>45'9"</b>	<b>45'9"</b>	<b>45'3"</b>	<b>45'10"</b>	<b>45'10"</b>	<b>1'3"</b>
Static tipping load, straight (with tire deflection)*	kg	12 769	12 629	12 912	12 649	12 507	12 789	-1277
	lb	<b>28,144</b>	<b>27,834</b>	<b>28,458</b>	<b>27,878</b>	<b>27,566</b>	<b>28,187</b>	<b>-2815</b>
Static tipping load, straight (no tire deflection)*	kg	13 510	13 368	13 658	13 391	13 248	13 537	-1436
	lb	<b>29,776</b>	<b>29,463</b>	<b>30,103</b>	<b>29,514</b>	<b>29,199</b>	<b>29,835</b>	<b>-3166</b>
Static tipping load, articulated (with tire deflection)*	kg	11 004	10 864	11 129	10 889	10 747	11 011	-1184
	lb	<b>24,254</b>	<b>23,944</b>	<b>24,529</b>	<b>23,999</b>	<b>23,687</b>	<b>24,268</b>	<b>-2610</b>
Static tipping load, articulated (no tire deflection)*	kg	11 759	11 617	11 889	11 645	11 502	11 772	-1334
	lb	<b>25,917</b>	<b>25,604</b>	<b>26,203</b>	<b>25,666</b>	<b>25,351</b>	<b>25,947</b>	<b>-2941</b>
Breakout force	kN	181	179	196	173	172	188	-9
	lbf	<b>40,706</b>	<b>40,421</b>	<b>44,216</b>	<b>39,080</b>	<b>38,797</b>	<b>42,322</b>	<b>-20</b>
Operating weight*	kg	19 214	19 322	19 165	19 283	19 391	19 234	602
	lb	<b>42,346</b>	<b>42,584</b>	<b>42,238</b>	<b>42,499</b>	<b>42,737</b>	<b>42,391</b>	<b>1327</b>

\*Static tipping loads and operating weights shown are based on a machine configuration with Michelin 23.5R25 XHA2 L3 radial tires, full fluids, operator, cold start, roading fenders, Product Link, Manual Diff Lock/Open axles (front/rear), power train guard, secondary steering and sound suppression. (With Tire Deflection) Full compliance to ISO 14397-1 (2007) Sections 1 thru 6, which requires 2% verification between calculations and testing. (No Tire Deflection) Compliance to ISO 14397-1 (2007) Sections 1 thru 5.

**NOTE:** Machine and bucket availability varies by region. Consult your local dealer for availability.

Bucket Type	General Purpose — Pin On							High Lift Delta
	Bucket Part Number	354-4853	354-4853	354-4853	354-4855	354-4855	354-4855	
Edge Type		Bolt-on Cutting Edges	Teeth & Segments	Tips	Bolt-on Cutting Edges	Teeth & Segments	Tips	
Capacity — rated	m <sup>3</sup>	3.40	3.40	3.20	3.60	3.60	3.40	—
	yd <sup>3</sup>	<b>4.45</b>	<b>4.45</b>	<b>4.19</b>	<b>4.71</b>	<b>4.71</b>	<b>4.45</b>	—
Capacity — 110%	m <sup>3</sup>	3.74	3.74	3.52	3.96	3.96	3.74	—
	yd <sup>3</sup>	<b>4.89</b>	<b>4.89</b>	<b>4.60</b>	<b>5.18</b>	<b>5.18</b>	<b>4.89</b>	—
Width	mm	2927	2994	2994	2927	2994	2994	—
	ft/in	<b>9'7"</b>	<b>9'9"</b>	<b>9'9"</b>	<b>9'7"</b>	<b>9'9"</b>	<b>9'9"</b>	—
Dump clearance at maximum lift and 45° discharge	mm	2819	2700	2700	2793	2673	2673	505
	ft/in	<b>9'3"</b>	<b>8'10"</b>	<b>8'10"</b>	<b>9'1"</b>	<b>8'9"</b>	<b>8'9"</b>	<b>1'7"</b>
Reach at maximum lift and 45° discharge	mm	1473	1582	1582	1495	1604	1604	36
	ft/in	<b>4'10"</b>	<b>5'2"</b>	<b>5'2"</b>	<b>4'10"</b>	<b>5'3"</b>	<b>5'3"</b>	<b>1"</b>
Reach at level lift arm and bucket level	mm	2761	2922	2922	2796	2957	2957	375
	ft/in	<b>9'0"</b>	<b>9'7"</b>	<b>9'7"</b>	<b>9'2"</b>	<b>9'8"</b>	<b>9'8"</b>	<b>1'2"</b>
Digging depth	mm	90	90	60	90	90	60	4
	in	<b>3.5</b>	<b>3.5</b>	<b>2.3</b>	<b>3.5</b>	<b>3.5</b>	<b>2.3</b>	<b>0</b>
Overall length	mm	8272	8445	8445	8307	8480	8480	583
	ft/in	<b>27'2"</b>	<b>27'9"</b>	<b>27'9"</b>	<b>27'4"</b>	<b>27'10"</b>	<b>27'10"</b>	<b>1'10"</b>
Overall height with bucket at maximum lift	mm	5597	5597	5597	5630	5630	5630	505
	ft/in	<b>18'5"</b>	<b>18'5"</b>	<b>18'5"</b>	<b>18'6"</b>	<b>18'6"</b>	<b>18'6"</b>	<b>1'7"</b>
Loader clearance circle with bucket at carry position	mm	13 805	13 975	13 975	13 826	13 997	13 997	393
	ft/in	<b>45'4"</b>	<b>45'11"</b>	<b>45'11"</b>	<b>45'5"</b>	<b>46'0"</b>	<b>46'0"</b>	<b>1'3"</b>
Static tipping load, straight (with tire deflection)*	kg	12 605	12 463	12 742	12 535	12 392	12 667	-1277
	lb	<b>27,783</b>	<b>27,469</b>	<b>28,083</b>	<b>27,627</b>	<b>27,313</b>	<b>27,918</b>	<b>-2815</b>
Static tipping load, straight (no tire deflection)*	kg	13 349	13 205	13 491	13 280	13 135	13 417	-1436
	lb	<b>29,421</b>	<b>29,105</b>	<b>29,734</b>	<b>29,270</b>	<b>28,951</b>	<b>29,572</b>	<b>-3166</b>
Static tipping load, articulated (with tire deflection)*	kg	10 847	10 705	10 966	10 780	10 637	10 895	-1184
	lb	<b>23,908</b>	<b>23,594</b>	<b>24,169</b>	<b>23,760</b>	<b>23,445</b>	<b>24,013</b>	<b>-2610</b>
Static tipping load, articulated (no tire deflection)*	kg	11 605	11 461	11 728	11 539	11 395	11 658	-1334
	lb	<b>25,577</b>	<b>25,260</b>	<b>25,849</b>	<b>25,433</b>	<b>25,115</b>	<b>25,696</b>	<b>-2941</b>
Breakout force	kN	170	169	184	165	164	179	-9
	lbf	<b>38,333</b>	<b>38,050</b>	<b>41,455</b>	<b>37,288</b>	<b>37,006</b>	<b>40,247</b>	<b>-20</b>
Operating weight*	kg	19 307	19 415	19 258	19 343	19 451	19 294	602
	lb	<b>42,552</b>	<b>42,790</b>	<b>42,444</b>	<b>42,632</b>	<b>42,870</b>	<b>42,524</b>	<b>1327</b>

\*Static tipping loads and operating weights shown are based on a machine configuration with Michelin 23.5R25 XHA2 L3 radial tires, full fluids, operator, cold start, roading fenders, Product Link, Manual Diff Lock/Open axles (front/rear), power train guard, secondary steering and sound suppression. (With Tire Deflection) Full compliance to ISO 14397-1 (2007) Sections 1 thru 6, which requires 2% verification between calculations and testing. (No Tire Deflection) Compliance to ISO 14397-1 (2007) Sections 1 thru 5.

**NOTE:** Machine and bucket availability varies by region. Consult your local dealer for availability.

Bucket Type Bucket Part Number	General Purpose — Pin On			Material Handling — Pin On			High Lift Delta	
	376-7800	376-7800	376-7800	354-4857	354-4857	354-4857		
Edge Type	Bolt-on Cutting Edges	Teeth & Segments	Tips	Bolt-on Cutting Edges	Teeth & Segments	Tips		
Capacity — rated	m <sup>3</sup> yd <sup>3</sup>	3.80 4.97	3.80 4.97	3.60 4.71	2.70 3.53	2.70 3.53	2.50 3.27	— —
Capacity — 110%	m <sup>3</sup> yd <sup>3</sup>	4.18 5.47	4.18 5.47	3.96 5.18	2.97 3.88	2.97 3.88	2.75 3.60	— —
Width	mm ft/in	2927 9'7"	2994 9'9"	2994 9'9"	2927 9'7"	2994 9'9"	2994 9'9"	— —
Dump clearance at maximum lift and 45° discharge	mm ft/in	2758 9'0"	2638 8'7"	2638 8'7"	2896 9'6"	2770 9'1"	2770 9'1"	505 1'7"
Reach at maximum lift and 45° discharge	mm ft/in	1524 5'0"	1632 5'4"	1632 5'4"	1272 4'2"	1374 4'6"	1374 4'6"	36 1"
Reach at level lift arm and bucket level	mm ft/in	2842 9'3"	3003 9'10"	3003 9'10"	2581 8'5"	2742 8'11"	2742 8'11"	375 1'2"
Digging depth	mm in	90 3.5	90 3.5	60 2.3	90 3.5	90 3.5	60 2.3	4 0
Overall length	mm ft/in	8353 27'5"	8526 28'0"	8526 28'0"	8092 26'7"	8265 27'2"	8265 27'2"	583 1'10"
Overall height with bucket at maximum lift	mm ft/in	5678 18'8"	5678 18'8"	5678 18'8"	5618 18'6"	5618 18'6"	5618 18'6"	505 1'7"
Loader clearance circle with bucket at carry position	mm ft/in	13 854 45'6"	14 025 46'1"	14 025 46'1"	13 700 45'0"	13 868 45'6"	13 868 45'6"	393 1'3"
Static tipping load, straight (with tire deflection)*	kg lb	12 435 27,408	12 292 27,091	12 562 27,687	12 832 28,282	12 695 27,980	13 023 28,703	-1277 -2815
Static tipping load, straight (no tire deflection)*	kg lb	13 182 29,054	13 037 28,734	13 314 29,344	13 548 29,861	13 409 29,555	13 748 30,301	-1436 -3166
Static tipping load, articulated (with tire deflection)*	kg lb	10 685 23,551	10 542 23,234	10 795 23,792	11 075 24,410	10 938 24,108	11 248 24,792	-1184 -2610
Static tipping load, articulated (no tire deflection)*	kg lb	11 446 25,228	11 301 24,908	11 560 25,478	11 806 26,021	11 667 25,716	11 988 26,422	-1334 -2941
Breakout force	kN lbf	160 35,985	158 35,705	172 38,748	198 44,633	197 44,343	217 48,847	-9 -20
Operating weight*	kg lb	19 398 42,753	19 506 42,991	19 349 42,645	19 115 42,128	19 223 42,366	19 066 42,020	602 1327

\*Static tipping loads and operating weights shown are based on a machine configuration with Michelin 23.5R25 XHA2 L3 radial tires, full fluids, operator, cold start, roading fenders, Product Link, Manual Diff Lock/Open axles (front/rear), power train guard, secondary steering and sound suppression. (With Tire Deflection) Full compliance to ISO 14397-1 (2007) Sections 1 thru 6, which requires 2% verification between calculations and testing. (No Tire Deflection) Compliance to ISO 14397-1 (2007) Sections 1 thru 5.

**NOTE:** Machine and bucket availability varies by region. Consult your local dealer for availability.

Bucket Type	Material Handling — Pin On							High Lift Delta
	Bucket Part Number	354-4859	354-4859	354-4859	354-4861	354-4861	354-4861	
Edge Type		Bolt-on Cutting Edges	Teeth & Segments	Tips	Bolt-on Cutting Edges	Teeth & Segments	Tips	
Capacity — rated	m <sup>3</sup>	2.90	2.90	2.70	3.10	3.10	2.90	—
	yd <sup>3</sup>	<b>3.79</b>	<b>3.79</b>	<b>3.53</b>	<b>4.05</b>	<b>4.05</b>	<b>3.79</b>	—
Capacity — 110%	m <sup>3</sup>	3.19	3.19	2.97	3.41	3.41	3.19	—
	yd <sup>3</sup>	<b>4.17</b>	<b>4.17</b>	<b>3.88</b>	<b>4.46</b>	<b>4.46</b>	<b>4.17</b>	—
Width	mm	2927	2994	2994	2927	2994	2994	—
	ft/in	<b>9'7"</b>	<b>9'9"</b>	<b>9'9"</b>	<b>9'7"</b>	<b>9'9"</b>	<b>9'9"</b>	—
Dump clearance at maximum lift and 45° discharge	mm	2853	2728	2728	2821	2696	2696	505
	ft/in	<b>9'4"</b>	<b>8'11"</b>	<b>8'11"</b>	<b>9'3"</b>	<b>8'10"</b>	<b>8'10"</b>	<b>1'7"</b>
Reach at maximum lift and 45° discharge	mm	1314	1416	1416	1346	1448	1448	36
	ft/in	<b>4'3"</b>	<b>4'7"</b>	<b>4'7"</b>	<b>4'5"</b>	<b>4'9"</b>	<b>4'9"</b>	<b>1"</b>
Reach at level lift arm and bucket level	mm	2641	2802	2802	2686	2847	2847	375
	ft/in	<b>8'8"</b>	<b>9'2"</b>	<b>9'2"</b>	<b>8'9"</b>	<b>9'4"</b>	<b>9'4"</b>	<b>1'2"</b>
Digging depth	mm	90	90	60	90	90	60	4
	in	<b>3.5</b>	<b>3.5</b>	<b>2.3</b>	<b>3.5</b>	<b>3.5</b>	<b>2.3</b>	<b>0</b>
Overall length	mm	8152	8325	8325	8197	8370	8370	583
	ft/in	<b>26'9"</b>	<b>27'4"</b>	<b>27'4"</b>	<b>26'11"</b>	<b>27'6"</b>	<b>27'6"</b>	<b>1'10"</b>
Overall height with bucket at maximum lift	mm	4975	4975	4975	5483	5483	5483	505
	ft/in	<b>16'4"</b>	<b>16'4"</b>	<b>16'4"</b>	<b>18'0"</b>	<b>18'0"</b>	<b>18'0"</b>	<b>1'7"</b>
Loader clearance circle with bucket at carry position	mm	13 734	13 903	13 903	13 761	13 930	13 930	393
	ft/in	<b>45'1"</b>	<b>45'8"</b>	<b>45'8"</b>	<b>45'2"</b>	<b>45'9"</b>	<b>45'9"</b>	<b>1'3"</b>
Static tipping load, straight (with tire deflection)*	kg	12 717	12 578	12 862	12 624	12 484	12 763	-1277
	lb	<b>28,028</b>	<b>27,723</b>	<b>28,349</b>	<b>27,823</b>	<b>27,516</b>	<b>28,129</b>	<b>-2815</b>
Static tipping load, straight (no tire deflection)*	kg	13 436	13 296	13 586	13 345	13 204	13 488	-1436
	lb	<b>29,613</b>	<b>29,304</b>	<b>29,944</b>	<b>29,412</b>	<b>29,102</b>	<b>29,729</b>	<b>-3166</b>
Static tipping load, articulated (with tire deflection)*	kg	10 966	10 828	11 094	10 878	10 738	11 000	-1184
	lb	<b>24,170</b>	<b>23,864</b>	<b>24,453</b>	<b>23,975</b>	<b>23,668</b>	<b>24,244</b>	<b>-2610</b>
Static tipping load, articulated (no tire deflection)*	kg	11 700	11 560	11 833	11 613	11 472	11 739	-1334
	lb	<b>25,786</b>	<b>25,478</b>	<b>26,080</b>	<b>25,596</b>	<b>25,286</b>	<b>25,874</b>	<b>-2941</b>
Breakout force	kN	188	187	205	181	180	197	-9
	lbf	<b>42,340</b>	<b>42,054</b>	<b>46,135</b>	<b>40,745</b>	<b>40,460</b>	<b>44,264</b>	<b>-20</b>
Operating weight*	kg	19 171	19 279	19 122	19 221	19 329	19 172	602
	lb	<b>42,252</b>	<b>42,490</b>	<b>42,144</b>	<b>42,362</b>	<b>42,600</b>	<b>42,254</b>	<b>1327</b>

\*Static tipping loads and operating weights shown are based on a machine configuration with Michelin 23.5R25 XHA2 L3 radial tires, full fluids, operator, cold start, roading fenders, Product Link, Manual Diff Lock/Open axles (front/rear), power train guard, secondary steering and sound suppression. (With Tire Deflection) Full compliance to ISO 14397-1 (2007) Sections 1 thru 6, which requires 2% verification between calculations and testing. (No Tire Deflection) Compliance to ISO 14397-1 (2007) Sections 1 thru 5.

**NOTE:** Machine and bucket availability varies by region. Consult your local dealer for availability.

Bucket Type Bucket Part Number	Material Handling — Pin On						High Lift Delta	
	354-4863	354-4863	354-4863	354-4865	354-4865	354-4865		
Edge Type	Bolt-on Cutting Edges	Teeth & Segments	Tips	Bolt-on Cutting Edges	Teeth & Segments	Tips		
Capacity — rated	m <sup>3</sup> yd <sup>3</sup>	3.30 4.32	3.30 4.32	3.10 4.05	3.40 4.45	3.40 4.45	3.20 4.19	— —
Capacity — 110%	m <sup>3</sup> yd <sup>3</sup>	3.63 4.75	3.63 4.75	3.41 4.46	3.74 4.89	3.74 4.89	3.52 4.60	— —
Width	mm ft/in	2927 9'7"	2994 9'9"	2994 9'9"	2927 9'7"	2994 9'9"	2994 9'9"	— —
Dump clearance at maximum lift and 45° discharge	mm ft/in	2789 9'1"	2664 8'8"	2664 8'8"	2761 9'0"	2636 8'7"	2636 8'7"	505 1'7"
Reach at maximum lift and 45° discharge	mm ft/in	1378 4'6"	1480 4'10"	1480 4'10"	1406 4'7"	1508 4'11"	1508 4'11"	36 1"
Reach at level lift arm and bucket level	mm ft/in	2731 9'11"	2892 9'5"	2892 9'5"	2771 9'1"	2932 9'7"	2932 9'7"	375 1'2"
Digging depth	mm in	90 3.5	90 3.5	60 2.3	90 3.5	90 3.5	60 2.3	4 0
Overall length	mm ft/in	8242 27'1"	8415 27'8"	8415 27'8"	8282 27'3"	8455 27'9"	8455 27'9"	583 1'10"
Overall height with bucket at maximum lift	mm ft/in	5527 18'2"	5527 18'2"	5527 18'2"	5566 18'4"	5566 18'4"	5566 18'4"	505 1'7"
Loader clearance circle with bucket at carry position	mm ft/in	13 787 45'3"	13 957 45'10"	13 957 45'10"	13 811 45'4"	13 981 45'11"	13 981 45'11"	393 1'3"
Static tipping load, straight (with tire deflection)*	kg lb	12 533 27,623	12 393 27,314	12 667 27,919	12 454 27,449	12 313 27,139	12 584 27,736	-1277 -2815
Static tipping load, straight (no tire deflection)*	kg lb	13 256 29,216	13 114 28,904	13 395 29,522	13 179 29,046	13 036 28,733	13 313 29,343	-1436 -3166
Static tipping load, articulated (with tire deflection)*	kg lb	10 791 23,784	10 651 23,475	10 909 24,044	10 716 23,619	10 575 23,309	10 830 23,870	-1184 -2610
Static tipping load, articulated (no tire deflection)*	kg lb	11 528 25,409	11 387 25,097	11 650 25,678	11 456 25,249	11 313 24,935	11 573 25,508	-1334 -2941
Breakout force	kN lbf	174 39,259	173 38,975	189 42,530	169 38,019	167 37,737	182 41,092	-9 -20
Operating weight*	kg lb	19 269 42,468	19 377 42,706	19 220 42,360	19 309 42,556	19 417 42,794	19 260 42,448	602 1327

\*Static tipping loads and operating weights shown are based on a machine configuration with Michelin 23.5R25 XHA2 L3 radial tires, full fluids, operator, cold start, roading fenders, Product Link, Manual Diff Lock/Open axles (front/rear), power train guard, secondary steering and sound suppression. (With Tire Deflection) Full compliance to ISO 14397-1 (2007) Sections 1 thru 6, which requires 2% verification between calculations and testing. (No Tire Deflection) Compliance to ISO 14397-1 (2007) Sections 1 thru 5.

**NOTE:** Machine and bucket availability varies by region. Consult your local dealer for availability.



Bucket Type		Material Handling — Pin On						High Lift Delta
Bucket Part Number		367-5733	367-5733	367-5733	354-4867	354-4867	354-4867	
Edge Type		Bolt-on Cutting Edges	Teeth & Segments	Tips	Bolt-on Cutting Edges	Teeth & Segments	Tips	
Capacity — rated	m <sup>3</sup>	3.60	3.60	3.40	3.80	3.80	3.60	—
	yd <sup>3</sup>	<b>4.71</b>	<b>4.71</b>	<b>4.45</b>	<b>4.97</b>	<b>4.97</b>	<b>4.71</b>	—
Capacity — 110%	m <sup>3</sup>	3.96	3.96	3.74	4.18	4.18	3.96	—
	yd <sup>3</sup>	<b>5.18</b>	<b>5.18</b>	<b>4.89</b>	<b>5.47</b>	<b>5.47</b>	<b>5.18</b>	—
Width	mm	2927	2994	2994	2927	2994	2994	—
	ft/in	<b>9'7"</b>	<b>9'9"</b>	<b>9'9"</b>	<b>9'7"</b>	<b>9'9"</b>	<b>9'9"</b>	—
Dump clearance at maximum lift and 45° discharge	mm	2729	2604	2604	2693	2568	2568	505
	ft/in	<b>8'11"</b>	<b>8'6"</b>	<b>8'6"</b>	<b>8'10"</b>	<b>8'5"</b>	<b>8'5"</b>	<b>1'7"</b>
Reach at maximum lift and 45° discharge	mm	1438	1540	1540	1474	1576	1576	36
	ft/in	<b>4'8"</b>	<b>5'0"</b>	<b>5'0"</b>	<b>4'10"</b>	<b>5'2"</b>	<b>5'2"</b>	<b>1"</b>
Reach at level lift arm and bucket level	mm	2816	2977	2977	2867	3028	3028	375
	ft/in	<b>9'2"</b>	<b>9'9"</b>	<b>9'9"</b>	<b>9'4"</b>	<b>9'11"</b>	<b>9'11"</b>	<b>1'2"</b>
Digging depth	mm	90	90	60	90	90	60	4
	in	<b>3.5</b>	<b>3.5</b>	<b>2.3</b>	<b>3.5</b>	<b>3.5</b>	<b>2.3</b>	<b>0</b>
Overall length	mm	8327	8500	8500	8378	8551	8551	583
	ft/in	<b>27'4"</b>	<b>27'11"</b>	<b>27'11"</b>	<b>27'6"</b>	<b>28'1"</b>	<b>28'1"</b>	<b>1'10"</b>
Overall height with bucket at maximum lift	mm	5614	5614	5614	5662	5662	5662	505
	ft/in	<b>18'6"</b>	<b>18'6"</b>	<b>18'6"</b>	<b>18'7"</b>	<b>18'7"</b>	<b>18'7"</b>	<b>1'7"</b>
Loader clearance circle with bucket at carry position	mm	13 838	14 009	14 009	13 869	14 041	14 041	393
	ft/in	<b>45'5"</b>	<b>46'0"</b>	<b>46'0"</b>	<b>45'6"</b>	<b>46'1"</b>	<b>46'1"</b>	<b>1'3"</b>
Static tipping load, straight (with tire deflection)*	kg	12 366	12 225	12 492	12 264	12 122	12 385	-1277
	lb	<b>27,256</b>	<b>26,944</b>	<b>27,533</b>	<b>27,031</b>	<b>26,717</b>	<b>27,296</b>	<b>-2815</b>
Static tipping load, straight (no tire deflection)*	kg	13 093	12 950	13 222	12 993	12 848	13 117	-1436
	lb	<b>28,857</b>	<b>28,542</b>	<b>29,143</b>	<b>28,636</b>	<b>28,318</b>	<b>28,911</b>	<b>-3166</b>
Static tipping load, articulated (with tire deflection)*	kg	10 633	10 491	10 742	10 536	10 393	10 640	-1184
	lb	<b>23,436</b>	<b>23,124</b>	<b>23,677</b>	<b>23,222</b>	<b>22,907</b>	<b>23,452</b>	<b>-2610</b>
Static tipping load, articulated (no tire deflection)*	kg	11 374	11 231	11 487	11 279	11 135	11 387	-1334
	lb	<b>25,069</b>	<b>24,754</b>	<b>25,318</b>	<b>24,859</b>	<b>24,541</b>	<b>25,097</b>	<b>-2941</b>
Breakout force	kN	163	162	176	157	155	169	-9
	lbf	<b>36,707</b>	<b>36,426</b>	<b>39,578</b>	<b>35,309</b>	<b>35,029</b>	<b>37,973</b>	<b>-20</b>
Operating weight*	kg	19 353	19 461	19 304	19 407	19 515	19 358	602
	lb	<b>42,653</b>	<b>42,891</b>	<b>42,545</b>	<b>42,772</b>	<b>43,010</b>	<b>42,664</b>	<b>1327</b>

\*Static tipping loads and operating weights shown are based on a machine configuration with Michelin 23.5R25 XHA2 L3 radial tires, full fluids, operator, cold start, roading fenders, Product Link, Manual Diff Lock/Open axles (front/rear), power train guard, secondary steering and sound suppression. (With Tire Deflection) Full compliance to ISO 14397-1 (2007) Sections 1 thru 6, which requires 2% verification between calculations and testing. (No Tire Deflection) Compliance to ISO 14397-1 (2007) Sections 1 thru 5.

**NOTE:** Machine and bucket availability varies by region. Consult your local dealer for availability.

Bucket Type Bucket Part Number	General Purpose — Hook On						High Lift Delta	
	354-4850	354-4850	354-4850	354-4852	354-4852	354-4852		
Edge Type	Bolt-on Cutting Edges	Teeth & Segments	Tips	Bolt-on Cutting Edges	Teeth & Segments	Tips		
Capacity — rated	m <sup>3</sup> yd <sup>3</sup>	2.70 3.53	2.70 3.53	2.50 3.27	2.90 3.79	2.90 3.79	2.70 3.53	— —
Capacity — 110%	m <sup>3</sup> yd <sup>3</sup>	2.97 3.88	2.97 3.88	2.75 3.60	3.19 4.17	3.19 4.17	2.97 3.88	— —
Width	mm ft/in	2927 9'7"	2994 9'9"	2994 9'9"	2927 9'7"	2994 9'9"	2994 9'9"	— —
Dump clearance at maximum lift and 45° discharge	mm ft/in	2936 9'7"	2820 9'3"	2820 9'3"	2880 9'5"	2763 9'0"	2763 9'0"	505 1'7"
Reach at maximum lift and 45° discharge	mm ft/in	1402 4'7"	1516 4'11"	1516 4'11"	1440 4'8"	1552 5'1"	1552 5'1"	36 1"
Reach at level lift arm and bucket level	mm ft/in	2622 8'7"	2783 9'1"	2783 9'1"	2691 8'9"	2852 9'4"	2852 9'4"	375 1'2"
Digging depth	mm in	90 3.5	90 3.5	60 2.3	90 3.5	90 3.5	60 2.3	4 0
Overall length	mm ft/in	8133 26'9"	8306 27'4"	8306 27'4"	8202 26'11"	8375 27'6"	8375 27'6"	583 1'10"
Overall height with bucket at maximum lift	mm ft/in	5424 17'10"	5424 17'10"	5424 17'10"	5497 18'1"	5497 18'1"	5497 18'1"	505 1'7"
Loader clearance circle with bucket at carry position	mm ft/in	13 714 45'0"	13 884 45'7"	13 884 45'7"	13 755 45'2"	13 926 45'9"	13 926 45'9"	393 1'3"
Static tipping load, straight (with tire deflection)*	kg lb	12 407 27,346	12 269 27,042	12 604 27,779	12 293 27,095	12 154 26,788	12 485 27,518	-1277 -2815
Static tipping load, straight (no tire deflection)*	kg lb	13 130 28,940	12 991 28,633	13 338 29,398	13 020 28,696	12 879 28,386	13 222 29,143	-1436 -3166
Static tipping load, articulated (with tire deflection)*	kg lb	10 658 23,490	10 520 23,187	10 835 23,882	10 549 23,250	10 410 22,943	10 722 23,633	-1184 -2610
Static tipping load, articulated (no tire deflection)*	kg lb	11 396 25,116	11 256 24,810	11 584 25,532	11 290 24,883	11 149 24,573	11 474 25,290	-1334 -2941
Breakout force	kN lbf	191 43,055	190 42,767	209 46,976	180 40,598	179 40,313	196 44,090	-9 -20
Operating weight*	kg lb	19 567 43,124	19 675 43,362	19 518 43,016	19 629 43,263	19 737 43,501	19 580 43,155	602 1327

\*Static tipping loads and operating weights shown are based on a machine configuration with Michelin 23.5R25 XHA2 L3 radial tires, full fluids, operator, cold start, roading fenders, Product Link, Manual Diff Lock/Open axles (front/rear), power train guard, secondary steering and sound suppression. (With Tire Deflection) Full compliance to ISO 14397-1 (2007) Sections 1 thru 6, which requires 2% verification between calculations and testing. (No Tire Deflection) Compliance to ISO 14397-1 (2007) Sections 1 thru 5.

**NOTE:** Machine and bucket availability varies by region. Consult your local dealer for availability.

Bucket Type Bucket Part Number		General Purpose — Hook On						High Lift Delta
		348-0242	348-0242	348-0242	348-0243	348-0243	348-0243	
Edge Type		Bolt-on Cutting Edges	Teeth & Segments	Tips	Bolt-on Cutting Edges	Teeth & Segments	Tips	
Capacity — rated	m <sup>3</sup>	3.10	3.10	2.90	3.30	3.30	3.10	—
	yd <sup>3</sup>	<b>4.05</b>	<b>4.05</b>	<b>3.79</b>	<b>4.32</b>	<b>4.32</b>	<b>4.05</b>	—
Capacity — 110%	m <sup>3</sup>	3.41	3.41	3.19	3.63	3.63	3.41	—
	yd <sup>3</sup>	<b>4.46</b>	<b>4.46</b>	<b>4.17</b>	<b>4.75</b>	<b>4.75</b>	<b>4.46</b>	—
Width	mm	2927	2994	2994	2927	2994	2994	—
	ft/in	<b>9'7"</b>	<b>9'9"</b>	<b>9'9"</b>	<b>9'7"</b>	<b>9'9"</b>	<b>9'9"</b>	—
Dump clearance at maximum lift and 45° discharge	mm	2837	2718	2718	2798	2679	2679	505
	ft/in	<b>9'3"</b>	<b>8'11"</b>	<b>8'11"</b>	<b>9'2"</b>	<b>8'9"</b>	<b>8'9"</b>	<b>1'7"</b>
Reach at maximum lift and 45° discharge	mm	1475	1585	1585	1503	1613	1613	36
	ft/in	<b>4'10"</b>	<b>5'2"</b>	<b>5'2"</b>	<b>4'11"</b>	<b>5'3"</b>	<b>5'3"</b>	<b>1"</b>
Reach at level lift arm and bucket level	mm	2748	2909	2909	2797	2958	2958	375
	ft/in	<b>9'0"</b>	<b>9'6"</b>	<b>9'6"</b>	<b>9'2"</b>	<b>9'8"</b>	<b>9'8"</b>	<b>1'2"</b>
Digging depth	mm	90	90	60	90	90	60	4
	in	<b>3.5</b>	<b>3.5</b>	<b>2.3</b>	<b>3.5</b>	<b>3.5</b>	<b>2.3</b>	<b>0</b>
Overall length	mm	8259	8432	8432	8308	8481	8481	583
	ft/in	<b>27'2"</b>	<b>27'8"</b>	<b>27'8"</b>	<b>27'4"</b>	<b>27'10"</b>	<b>27'10"</b>	<b>1'10"</b>
Overall height with bucket at maximum lift	mm	5558	5558	5558	5604	5604	5604	505
	ft/in	<b>18'3"</b>	<b>18'3"</b>	<b>18'3"</b>	<b>18'5"</b>	<b>18'5"</b>	<b>18'5"</b>	<b>1'7"</b>
Loader clearance circle with bucket at carry position	mm	13 789	13 961	13 961	13 818	13 991	13 991	393
	ft/in	<b>45'3"</b>	<b>45'10"</b>	<b>45'10"</b>	<b>45'5"</b>	<b>45'11"</b>	<b>45'11"</b>	<b>1'3"</b>
Static tipping load, straight (with tire deflection)*	kg	12 183	12 043	12 373	12 093	11 952	12 281	-1277
	lb	<b>26,853</b>	<b>26,544</b>	<b>27,271</b>	<b>26,654</b>	<b>26,343</b>	<b>27,067</b>	<b>-2815</b>
Static tipping load, straight (no tire deflection)*	kg	12 913	12 771	13 113	12 825	12 682	13 023	-1436
	lb	<b>28,461</b>	<b>28,148</b>	<b>28,902</b>	<b>28,267</b>	<b>27,952</b>	<b>28,703</b>	<b>-3166</b>
Static tipping load, articulated (with tire deflection)*	kg	10 445	10 305	10 617	10 359	10 218	10 529	-1184
	lb	<b>23,022</b>	<b>22,713</b>	<b>23,400</b>	<b>22,833</b>	<b>22,522</b>	<b>23,207</b>	<b>-2610</b>
Static tipping load, articulated (no tire deflection)*	kg	11 189	11 047	11 371	11 106	10 963	11 286	-1334
	lb	<b>24,661</b>	<b>24,349</b>	<b>25,063</b>	<b>24,477</b>	<b>24,163</b>	<b>24,874</b>	<b>-2941</b>
Breakout force	kN	172	171	186	165	164	179	-9
	lbf	<b>38,754</b>	<b>38,471</b>	<b>41,942</b>	<b>37,284</b>	<b>37,003</b>	<b>40,241</b>	<b>-20</b>
Operating weight*	kg	19 683	19 791	19 634	19 730	19 838	19 681	602
	lb	<b>43,382</b>	<b>43,620</b>	<b>43,274</b>	<b>43,484</b>	<b>43,722</b>	<b>43,376</b>	<b>1327</b>

\*Static tipping loads and operating weights shown are based on a machine configuration with Michelin 23.5R25 XHA2 L3 radial tires, full fluids, operator, cold start, roading fenders, Product Link, Manual Diff Lock/Open axles (front/rear), power train guard, secondary steering and sound suppression. (With Tire Deflection) Full compliance to ISO 14397-1 (2007) Sections 1 thru 6, which requires 2% verification between calculations and testing. (No Tire Deflection) Compliance to ISO 14397-1 (2007) Sections 1 thru 5.

**NOTE:** Machine and bucket availability varies by region. Consult your local dealer for availability.

Bucket Type Bucket Part Number	General Purpose — Hook On						High Lift Delta	
	354-4854	354-4854	354-4854	354-4856	354-4856	354-4856		
Edge Type	Bolt-on Cutting Edges	Teeth & Segments	Tips	Bolt-on Cutting Edges	Teeth & Segments	Tips		
Capacity — rated	m <sup>3</sup> yd <sup>3</sup>	3.40 4.45	3.40 4.45	3.20 4.19	3.60 4.71	3.60 4.71	3.40 4.45	— —
Capacity — 110%	m <sup>3</sup> yd <sup>3</sup>	3.74 4.89	3.74 4.89	3.52 4.60	3.96 5.18	3.96 5.18	3.74 4.89	— —
Width	mm ft/in	2927 9'7"	2994 9'9"	2994 9'9"	2927 9'7"	2994 9'9"	2994 9'9"	— —
Dump clearance at maximum lift and 45° discharge	mm ft/in	2779 9'1"	2660 8'8"	2660 8'8"	2753 9'0"	2633 8'7"	2633 8'7"	505 1'7"
Reach at maximum lift and 45° discharge	mm ft/in	1518 4'11"	1627 5'4"	1627 5'4"	1539 5'0"	1648 5'4"	1648 5'4"	36 1"
Reach at level lift arm and bucket level	mm ft/in	2821 9'3"	2982 9'9"	2982 9'9"	2856 9'4"	3017 9'10"	3017 9'10"	375 1'2"
Digging depth	mm in	90 3.5	90 3.5	60 2.3	90 3.5	90 3.5	60 2.3	4 0
Overall length	mm ft/in	8332 27'5"	8505 27'11"	8505 27'11"	8367 27'6"	8540 28'1"	8540 28'1"	583 1'10"
Overall height with bucket at maximum lift	mm ft/in	5630 18'6"	5630 18'6"	5630 18'6"	5664 18'7"	5664 18'7"	5664 18'7"	505 1'7"
Loader clearance circle with bucket at carry position	mm ft/in	13 833 45'5"	14 006 46'0"	14 006 46'0"	13 854 45'6"	14 028 46'1"	14 028 46'1"	393 1'3"
Static tipping load, straight (with tire deflection)*	kg lb	12 051 26,561	11 909 26,249	12 237 26,971	11 986 26,417	11 843 26,103	12 170 26,824	-1277 -2815
Static tipping load, straight (no tire deflection)*	kg lb	12 784 28,176	12 641 27,860	12 981 28,610	12 720 28,035	12 576 27,718	12 915 28,466	-1436 -3166
Static tipping load, articulated (with tire deflection)*	kg lb	10 319 22,744	10 178 22,432	10 488 23,116	10 257 22,607	10 115 22,294	10 425 22,976	-1184 -2610
Static tipping load, articulated (no tire deflection)*	kg lb	11 066 24,391	10 923 24,075	11 245 24,785	11 006 24,257	10 862 23,940	11 183 24,649	-1334 -2941
Breakout force	kN lbf	162 36,598	161 36,318	175 39,451	158 35,639	157 35,359	170 38,348	-9 -20
Operating weight*	kg lb	19 753 43,536	19 861 43,774	19 704 43,428	19 787 43,611	19 895 43,849	19 738 43,503	602 1327

\*Static tipping loads and operating weights shown are based on a machine configuration with Michelin 23.5R25 XHA2 L3 radial tires, full fluids, operator, cold start, roading fenders, Product Link, Manual Diff Lock/Open axles (front/rear), power train guard, secondary steering and sound suppression. (With Tire Deflection) Full compliance to ISO 14397-1 (2007) Sections 1 thru 6, which requires 2% verification between calculations and testing. (No Tire Deflection) Compliance to ISO 14397-1 (2007) Sections 1 thru 5.

**NOTE:** Machine and bucket availability varies by region. Consult your local dealer for availability.

Bucket Type Bucket Part Number	General Purpose — Hook On			Material Handling — Hook On			High Lift Delta	
	376-7801	376-7801	376-7801	354-4858	354-4858	354-4858		
Edge Type	Bolt-on Cutting Edges	Teeth & Segments	Tips	Bolt-on Cutting Edges	Teeth & Segments	Tips		
Capacity — rated	m <sup>3</sup> yd <sup>3</sup>	3.80 4.97	3.80 4.97	3.60 4.71	2.70 3.53	2.70 3.53	2.50 3.27	— —
Capacity — 110%	m <sup>3</sup> yd <sup>3</sup>	4.18 5.47	4.18 5.47	3.96 5.18	2.97 3.88	2.97 3.88	2.75 3.60	— —
Width	mm ft/in	2927 9'7"	2994 9'9"	2994 9'9"	2927 9'7"	2994 9'9"	2994 9'9"	— —
Dump clearance at maximum lift and 45° discharge	mm ft/in	2718 8'11"	2598 8'6"	2598 8'6"	2853 9'4"	2728 8'11"	2728 8'11"	505 1'7"
Reach at maximum lift and 45° discharge	mm ft/in	1568 5'1"	1677 5'6"	1677 5'6"	1314 4'3"	1416 4'7"	1416 4'7"	36 1"
Reach at level lift arm and bucket level	mm ft/in	2902 9'6"	3063 10'0"	3063 10'0"	2641 8'8"	2802 9'2"	2802 9'2"	375 1'2"
Digging depth	mm in	90 3.5	90 3.5	60 2.3	90 3.5	90 3.5	60 2.3	4 0
Overall length	mm ft/in	8413 27'8"	8586 28'3"	8586 28'3"	8152 26'9"	8325 27'4"	8325 27'4"	583 1'10"
Overall height with bucket at maximum lift	mm ft/in	5711 18'9"	5711 18'9"	5711 18'9"	5418 17'10"	5418 17'10"	5418 17'10"	505 1'7"
Loader clearance circle with bucket at carry position	mm ft/in	13 883 45'7"	14 057 46'2"	14 057 46'2"	13 725 45'1"	13 895 45'8"	13 895 45'8"	393 1'3"
Static tipping load, straight (with tire deflection)*	kg lb	11 899 26,227	11 756 25,912	12 082 26,630	12 263 27,027	12 126 26,726	12 445 27,430	-1277 -2815
Static tipping load, straight (no tire deflection)*	kg lb	12 636 27,850	12 491 27,531	12 829 28,276	12 970 28,586	12 831 28,281	13 161 29,008	-1436 -3166
Static tipping load, articulated (with tire deflection)*	kg lb	10 175 22,427	10 032 22,111	10 341 22,792	10 532 23,213	10 395 22,911	10 698 23,579	-1184 -2610
Static tipping load, articulated (no tire deflection)*	kg lb	10 926 24,081	10 781 23,762	11 102 24,469	11 254 24,804	11 116 24,500	11 428 25,189	-1334 -2941
Breakout force	kN lbf	153 34,442	152 34,164	164 36,981	188 42,345	187 42,059	205 46,141	-9 -20
Operating weight*	kg lb	19 832 43,710	19 940 43,948	19 783 43,602	19 573 43,137	19 681 43,375	19 524 43,029	602 1327

\*Static tipping loads and operating weights shown are based on a machine configuration with Michelin 23.5R25 XHA2 L3 radial tires, full fluids, operator, cold start, roading fenders, Product Link, Manual Diff Lock/Open axles (front/rear), power train guard, secondary steering and sound suppression. (With Tire Deflection) Full compliance to ISO 14397-1 (2007) Sections 1 thru 6, which requires 2% verification between calculations and testing. (No Tire Deflection) Compliance to ISO 14397-1 (2007) Sections 1 thru 5.

**NOTE:** Machine and bucket availability varies by region. Consult your local dealer for availability.

Bucket Type	Material Handling — Hook On							High Lift Delta
	Bucket Part Number	354-4860	354-4860	354-4860	354-4862	354-4862	354-4862	
Edge Type		Bolt-on Cutting Edges	Teeth & Segments	Tips	Bolt-on Cutting Edges	Teeth & Segments	Tips	
Capacity — rated	m <sup>3</sup>	2.90	2.90	2.70	3.10	3.10	2.90	—
	yd <sup>3</sup>	<b>3.79</b>	<b>3.79</b>	<b>3.53</b>	<b>4.05</b>	<b>4.05</b>	<b>3.79</b>	—
Capacity — 110%	m <sup>3</sup>	3.19	3.19	2.97	3.41	3.41	3.19	—
	yd <sup>3</sup>	<b>4.17</b>	<b>4.17</b>	<b>3.88</b>	<b>4.46</b>	<b>4.46</b>	<b>4.17</b>	—
Width	mm	2927	2994	2994	2927	2994	2994	—
	ft/in	<b>9'7"</b>	<b>9'9"</b>	<b>9'9"</b>	<b>9'7"</b>	<b>9'9"</b>	<b>9'9"</b>	—
Dump clearance at maximum lift and 45° discharge	mm	2811	2685	2685	2779	2653	2653	505
	ft/in	<b>9'2"</b>	<b>8'9"</b>	<b>8'9"</b>	<b>9'1"</b>	<b>8'8"</b>	<b>8'8"</b>	<b>1'7"</b>
Reach at maximum lift and 45° discharge	mm	1357	1459	1459	1389	1491	1491	36
	ft/in	<b>4'5"</b>	<b>4'9"</b>	<b>4'9"</b>	<b>4'6"</b>	<b>4'10"</b>	<b>4'10"</b>	<b>1"</b>
Reach at level lift arm and bucket level	mm	2701	2862	2862	2746	2907	2907	375
	ft/in	<b>8'10"</b>	<b>9'4"</b>	<b>9'4"</b>	<b>9'0"</b>	<b>9'6"</b>	<b>9'6"</b>	<b>1'2"</b>
Digging depth	mm	90	90	60	90	90	60	4
	in	<b>3.5</b>	<b>3.5</b>	<b>2.3</b>	<b>3.5</b>	<b>3.5</b>	<b>2.3</b>	<b>0</b>
Overall length	mm	8212	8385	8385	8257	8430	8430	583
	ft/in	<b>27'0"</b>	<b>27'7"</b>	<b>27'7"</b>	<b>27'2"</b>	<b>27'8"</b>	<b>27'8"</b>	<b>1'10"</b>
Overall height with bucket at maximum lift	mm	5480	5480	5480	5517	5517	5517	505
	ft/in	<b>18'0"</b>	<b>18'0"</b>	<b>18'0"</b>	<b>18'2"</b>	<b>18'2"</b>	<b>18'2"</b>	<b>1'7"</b>
Loader clearance circle with bucket at carry position	mm	13 761	13 932	13 932	13 788	13 959	13 959	393
	ft/in	<b>45'2"</b>	<b>45'9"</b>	<b>45'9"</b>	<b>45'3"</b>	<b>45'10"</b>	<b>45'10"</b>	<b>1'3"</b>
Static tipping load, straight (with tire deflection)*	kg	12 158	12 020	12 336	12 066	11 927	12 244	-1277
	lb	<b>26,796</b>	<b>26,492</b>	<b>27,190</b>	<b>26,595</b>	<b>26,289</b>	<b>26,986</b>	<b>-2815</b>
Static tipping load, straight (no tire deflection)*	kg	12 867	12 728	13 055	12 777	12 637	12 964	-1436
	lb	<b>28,360</b>	<b>28,053</b>	<b>28,773</b>	<b>28,162</b>	<b>27,853</b>	<b>28,573</b>	<b>-3166</b>
Static tipping load, articulated (with tire deflection)*	kg	10 433	10 295	10 595	10 346	10 207	10 507	-1184
	lb	<b>22,994</b>	<b>22,690</b>	<b>23,352</b>	<b>22,803</b>	<b>22,497</b>	<b>23,159</b>	<b>-2610</b>
Static tipping load, articulated (no tire deflection)*	kg	11 157	11 018	11 328	11 072	10 932	11 242	-1334
	lb	<b>24,591</b>	<b>24,284</b>	<b>24,968</b>	<b>24,403</b>	<b>24,094</b>	<b>24,778</b>	<b>-2941</b>
Breakout force	kN	179	177	194	172	171	186	-9
	lbf	<b>40,263</b>	<b>39,978</b>	<b>43,698</b>	<b>38,805</b>	<b>38,522</b>	<b>42,002</b>	<b>-20</b>
Operating weight*	kg	19 625	19 733	19 576	19 674	19 782	19 625	602
	lb	<b>43,252</b>	<b>43,490</b>	<b>43,144</b>	<b>43,360</b>	<b>43,598</b>	<b>43,252</b>	<b>1327</b>

\*Static tipping loads and operating weights shown are based on a machine configuration with Michelin 23.5R25 XHA2 L3 radial tires, full fluids, operator, cold start, roading fenders, Product Link, Manual Diff Lock/Open axles (front/rear), power train guard, secondary steering and sound suppression. (With Tire Deflection) Full compliance to ISO 14397-1 (2007) Sections 1 thru 6, which requires 2% verification between calculations and testing. (No Tire Deflection) Compliance to ISO 14397-1 (2007) Sections 1 thru 5.

**NOTE:** Machine and bucket availability varies by region. Consult your local dealer for availability.

Bucket Type	Material Handling — Hook On							High Lift Delta
	Bucket Part Number	354-4864	354-4864	354-4864	354-4866	354-4866	354-4866	
Edge Type		Bolt-on Cutting Edges	Teeth & Segments	Tips	Bolt-on Cutting Edges	Teeth & Segments	Tips	
Capacity — rated	m <sup>3</sup>	3.30	3.30	3.10	3.40	3.40	3.20	—
	yd <sup>3</sup>	<b>4.32</b>	<b>4.32</b>	<b>4.05</b>	<b>4.45</b>	<b>4.45</b>	<b>4.19</b>	—
Capacity — 110%	m <sup>3</sup>	3.63	3.63	3.41	3.74	3.74	3.52	—
	yd <sup>3</sup>	<b>4.75</b>	<b>4.75</b>	<b>4.46</b>	<b>4.89</b>	<b>4.89</b>	<b>4.60</b>	—
Width	mm	2927	2994	2994	2927	2994	2994	—
	ft/in	<b>9'7"</b>	<b>9'9"</b>	<b>9'9"</b>	<b>9'7"</b>	<b>9'9"</b>	<b>9'9"</b>	—
Dump clearance at maximum lift and 45° discharge	mm	2747	2622	2622	2719	2593	2593	505
	ft/in	<b>9'0"</b>	<b>8'7"</b>	<b>8'7"</b>	<b>8'11"</b>	<b>8'6"</b>	<b>8'6"</b>	<b>1'7"</b>
Reach at maximum lift and 45° discharge	mm	1420	1523	1523	1449	1551	1551	36
	ft/in	<b>4'7"</b>	<b>4'11"</b>	<b>4'11"</b>	<b>4'9"</b>	<b>5'1"</b>	<b>5'1"</b>	<b>1"</b>
Reach at level lift arm and bucket level	mm	2791	2952	2952	2831	2992	2992	375
	ft/in	<b>9'1"</b>	<b>9'8"</b>	<b>9'8"</b>	<b>9'3"</b>	<b>9'9"</b>	<b>9'9"</b>	<b>1'2"</b>
Digging depth	mm	90	90	60	90	90	60	4
	in	<b>3.5</b>	<b>3.5</b>	<b>2.3</b>	<b>3.5</b>	<b>3.5</b>	<b>2.3</b>	<b>0</b>
Overall length	mm	8302	8475	8475	8342	8515	8515	583
	ft/in	<b>27'3"</b>	<b>27'10"</b>	<b>27'10"</b>	<b>27'5"</b>	<b>28'0"</b>	<b>28'0"</b>	<b>1'10"</b>
Overall height with bucket at maximum lift	mm	5561	5561	5561	5600	5600	5600	505
	ft/in	<b>18'3"</b>	<b>18'3"</b>	<b>18'3"</b>	<b>18'5"</b>	<b>18'5"</b>	<b>18'5"</b>	<b>1'7"</b>
Loader clearance circle with bucket at carry position	mm	13 815	13 987	13 987	13 839	14 012	14 012	393
	ft/in	<b>45'4"</b>	<b>45'11"</b>	<b>45'11"</b>	<b>45'5"</b>	<b>46'0"</b>	<b>46'0"</b>	<b>1'3"</b>
Static tipping load, straight (with tire deflection)*	kg	11 980	11 840	12 160	11 909	11 768	12 085	-1277
	lb	<b>26,404</b>	<b>26,096</b>	<b>26,802</b>	<b>26,247</b>	<b>25,938</b>	<b>26,636</b>	<b>-2815</b>
Static tipping load, straight (no tire deflection)*	kg	12 693	12 551	12 883	12 624	12 482	12 809	-1436
	lb	<b>27,975</b>	<b>27,664</b>	<b>28,394</b>	<b>27,823</b>	<b>27,510</b>	<b>28,231</b>	<b>-3166</b>
Static tipping load, articulated (with tire deflection)*	kg	10 264	10 124	10 428	10 196	10 056	10 357	-1184
	lb	<b>22,622</b>	<b>22,315</b>	<b>22,983</b>	<b>22,473</b>	<b>22,164</b>	<b>22,826</b>	<b>-2610</b>
Static tipping load, articulated (no tire deflection)*	kg	10 992	10 851	11 165	10 926	10 784	11 095	-1334
	lb	<b>24,226</b>	<b>23,915</b>	<b>24,608</b>	<b>24,082</b>	<b>23,769</b>	<b>24,454</b>	<b>-2941</b>
Breakout force	kN	166	165	179	161	160	174	-9
	lbf	<b>37,446</b>	<b>37,165</b>	<b>40,429</b>	<b>36,309</b>	<b>36,029</b>	<b>39,119</b>	<b>-20</b>
Operating weight*	kg	19 718	19 826	19 669	19 756	19 864	19 707	602
	lb	<b>43,457</b>	<b>43,695</b>	<b>43,349</b>	<b>43,541</b>	<b>43,779</b>	<b>43,433</b>	<b>1327</b>

\*Static tipping loads and operating weights shown are based on a machine configuration with Michelin 23.5R25 XHA2 L3 radial tires, full fluids, operator, cold start, roading fenders, Product Link, Manual Diff Lock/Open axles (front/rear), power train guard, secondary steering and sound suppression. (With Tire Deflection) Full compliance to ISO 14397-1 (2007) Sections 1 thru 6, which requires 2% verification between calculations and testing. (No Tire Deflection) Compliance to ISO 14397-1 (2007) Sections 1 thru 5.

**NOTE:** Machine and bucket availability varies by region. Consult your local dealer for availability.

Bucket Type	Material Handling — Hook On						High Lift Delta	
	367-5735	367-5735	367-5735	354-4868	354-4868	354-4868		
Bucket Part Number	Bolt-on Cutting Edges	Teeth & Segments	Tips	Bolt-on Cutting Edges	Teeth & Segments	Tips		
Edge Type								
Capacity — rated	m <sup>3</sup> yd <sup>3</sup>	3.60 4.71	3.60 4.71	3.40 4.45	3.80 4.97	3.80 4.97	3.60 4.71	— —
Capacity — 110%	m <sup>3</sup> yd <sup>3</sup>	3.96 5.18	3.96 5.18	3.74 4.89	4.18 5.47	4.18 5.47	3.96 5.18	— —
Width	mm ft/in	2927 9'7"	2994 9'9"	2994 9'9"	2927 9'7"	2994 9'9"	2994 9'9"	— —
Dump clearance at maximum lift and 45° discharge	mm ft/in	2687 8'9"	2561 8'4"	2561 8'4"	2651 8'8"	2525 8'3"	2525 8'3"	505 1'7"
Reach at maximum lift and 45° discharge	mm ft/in	1480 4'10"	1583 5'2"	1583 5'2"	1517 4'11"	1619 5'3"	1619 5'3"	36 1"
Reach at level lift arm and bucket level	mm ft/in	2876 9'5"	3037 9'11"	3037 9'11"	2927 9'7"	3088 10'1"	3088 10'1"	375 12"
Digging depth	mm in	90 3.5	90 3.5	60 2.3	90 3.5	90 3.5	60 2.3	4 0
Overall length	mm ft/in	8387 27'7"	8560 28'2"	8560 28'2"	8438 27'9"	8611 28'4"	8611 28'4"	583 1'10"
Overall height with bucket at maximum lift	mm ft/in	5643 18'7"	5643 18'7"	5643 18'7"	5697 18'9"	5697 18'9"	5697 18'9"	505 1'7"
Loader clearance circle with bucket at carry position	mm ft/in	13 867 45'6"	14 040 46'1"	14 040 46'1"	13 898 45'8"	14 073 46'3"	14 073 46'3"	393 1'3"
Static tipping load, straight (with tire deflection)*	kg lb	11 826 26,066	11 685 25,755	12 002 26,454	11 727 25,848	11 585 25,535	11 903 26,234	-1277 -2815
Static tipping load, straight (no tire deflection)*	kg lb	12 543 27,644	12 400 27,330	12 728 28,053	12 446 27,431	12 302 27,114	12 630 27,838	-1436 -3166
Static tipping load, articulated (with tire deflection)*	kg lb	10 119 22,302	9977 21,991	10 279 22,655	10 024 22,094	9882 21,781	10 184 22,445	-1184 -2610
Static tipping load, articulated (no tire deflection)*	kg lb	10 850 23,913	10 707 23,599	11 019 24,286	10 758 23,710	10 614 23,394	10 926 24,081	-1334 -2941
Breakout force	kN lbf	156 35,106	155 34,827	167 37,739	150 33,811	149 33,533	161 36,262	-9 -20
Operating weight*	kg lb	19 796 43,629	19 904 43,867	19 747 43,521	19 850 43,748	19 958 43,986	19 801 43,640	602 1327

\*Static tipping loads and operating weights shown are based on a machine configuration with Michelin 23.5R25 XHA2 L3 radial tires, full fluids, operator, cold start, roading fenders, Product Link, Manual Diff Lock/Open axles (front/rear), power train guard, secondary steering and sound suppression. (With Tire Deflection) Full compliance to ISO 14397-1 (2007) Sections 1 thru 6, which requires 2% verification between calculations and testing. (No Tire Deflection) Compliance to ISO 14397-1 (2007) Sections 1 thru 5.

**NOTE:** Machine and bucket availability varies by region. Consult your local dealer for availability.



Bucket Type		General Purpose — Pin On						High Lift Delta
Bucket Part Number		391-4950	391-4950	391-4950	394-8476	394-8476	394-8476	
Edge Type		Bolt-on Cutting Edges	Teeth & Segments	Tips	Bolt-on Cutting Edges	Teeth & Segments	Tips	
Capacity — rated	m <sup>3</sup>	3.10	3.10	2.90	3.40	3.40	3.20	—
	yd <sup>3</sup>	<b>4.05</b>	<b>4.05</b>	<b>3.79</b>	<b>4.45</b>	<b>4.45</b>	<b>4.19</b>	—
Capacity — 110%	m <sup>3</sup>	3.41	3.41	3.19	3.74	3.74	3.52	—
	yd <sup>3</sup>	<b>4.46</b>	<b>4.46</b>	<b>4.17</b>	<b>4.89</b>	<b>4.89</b>	<b>4.60</b>	—
Width	mm	2927	2994	2994	2927	2994	2994	—
	ft/in	<b>9'7"</b>	<b>9'9"</b>	<b>9'9"</b>	<b>9'7"</b>	<b>9'9"</b>	<b>9'9"</b>	—
Dump clearance at maximum lift and 45° discharge	mm	2856	2738	2738	2791	2672	2672	495
	ft/in	<b>9'4"</b>	<b>8'11"</b>	<b>8'11"</b>	<b>9'1"</b>	<b>8'9"</b>	<b>8'9"</b>	<b>1'7"</b>
Reach at maximum lift and 45° discharge	mm	1319	1430	1430	1371	1481	1481	67
	ft/in	<b>4'3"</b>	<b>4'8"</b>	<b>4'8"</b>	<b>4'5"</b>	<b>4'10"</b>	<b>4'10"</b>	<b>2"</b>
Reach at level lift arm and bucket level	mm	2627	2788	2788	2712	2873	2873	405
	ft/in	<b>8'7"</b>	<b>9'1"</b>	<b>9'1"</b>	<b>8'10"</b>	<b>9'5"</b>	<b>9'5"</b>	<b>1'3"</b>
Digging depth	mm	89	89	59	89	89	59	21
	in	<b>3.5</b>	<b>3.5</b>	<b>2.3</b>	<b>3.5</b>	<b>3.5</b>	<b>2.3</b>	<b>0.8</b>
Overall length	mm	8069	8243	8243	8154	8328	8328	652
	ft/in	<b>26'6"</b>	<b>27'1"</b>	<b>27'1"</b>	<b>26'9"</b>	<b>27'4"</b>	<b>27'4"</b>	<b>5'2"</b>
Overall height with bucket at maximum lift	mm	5325	5325	5325	5529	5529	5529	496
	ft/in	<b>17'6"</b>	<b>17'6"</b>	<b>17'6"</b>	<b>18'2"</b>	<b>18'2"</b>	<b>18'2"</b>	<b>1'8"</b>
Loader clearance circle with bucket at carry position	mm	6678	6760	6760	6702	6784	6784	391
	ft/in	<b>21'11"</b>	<b>22'3"</b>	<b>22'3"</b>	<b>22'0"</b>	<b>22'4"</b>	<b>22'4"</b>	<b>1'4"</b>
Static tipping load, straight (with tire deflection)*	kg	12 621	12 481	12 746	12 463	12 322	12 573	-776
	lb	<b>27,818</b>	<b>27,509</b>	<b>28,093</b>	<b>27,470</b>	<b>27,158</b>	<b>27,712</b>	<b>-1712</b>
Static tipping load, straight (no tire deflection)*	kg	13 314	13 173	13 443	13 159	13 017	13 272	-854
	lb	<b>29,344</b>	<b>29,033</b>	<b>29,628</b>	<b>29,004</b>	<b>28,689</b>	<b>29,252</b>	<b>-1884</b>
Static tipping load, articulated (with tire deflection)*	kg	10 926	10 786	11 034	10 776	10 635	10 871	-780
	lb	<b>24,081</b>	<b>23,772</b>	<b>24,319</b>	<b>23,751</b>	<b>23,440</b>	<b>23,960</b>	<b>-1719</b>
Static tipping load, articulated (no tire deflection)*	kg	11 624	11 483	11 735	11 478	11 335	11 574	-845
	lb	<b>25,620</b>	<b>25,309</b>	<b>25,865</b>	<b>25,298</b>	<b>24,984</b>	<b>25,510</b>	<b>-1863</b>
Breakout force	kN	152	151	165	141	140	153	-8
	lbf	<b>34,195</b>	<b>33,930</b>	<b>37,177</b>	<b>31,889</b>	<b>31,625</b>	<b>34,495</b>	<b>-1939</b>
Operating weight*	kg	18 136	18 244	18 087	18 211	18 319	18 162	1137
	lb	<b>39,971</b>	<b>40,209</b>	<b>39,863</b>	<b>40,137</b>	<b>40,375</b>	<b>40,029</b>	<b>2505</b>

\*Static tipping loads and operating weights shown are based on a machine configuration with Michelin 23.5R25 XHA2 L3 radial tires, full fluids, operator, cold start, roading fenders, Product Link, Open/Open axles (front/rear), power train guard, secondary steering and sound suppression.

(With Tire Deflection) Full compliance to ISO 14397-1 (2007) Sections 1 thru 6, which requires 2% verification between calculations and testing.

(No Tire Deflection) Compliance to ISO 14397-1 (2007) Sections 1 thru 5.

**NOTE:** Machine and bucket availability varies by region. Consult your local dealer for availability.

Bucket Type Bucket Part Number	General Purpose — Hook On			Material Handling — Pin On			High Lift Delta	
	382-9834	382-9834	382-9834	396-1540	396-1540	396-1540		
Edge Type	Bolt-on Cutting Edges	Teeth & Segments	Tips	Bolt-on Cutting Edges	Teeth & Segments	Tips		
Capacity — rated	m <sup>3</sup> yd <sup>3</sup>	3.10 4.05	3.10 4.05	2.90 3.79	3.40 4.45	3.40 4.45	3.20 4.19	— —
Capacity — 110%	m <sup>3</sup> yd <sup>3</sup>	3.41 4.46	3.41 4.46	3.19 4.17	3.74 4.89	3.74 4.89	3.52 4.60	— —
Width	mm ft/in	2927 9'7"	2994 9'9"	2994 9'9"	2927 9'7"	2994 9'9"	2994 9'9"	— —
Dump clearance at maximum lift and 45° discharge	mm ft/in	2814 9'2"	2697 8'10"	2697 8'10"	2721 8'11"	2596 8'6"	2596 8'6"	495 1'7"
Reach at maximum lift and 45° discharge	mm ft/in	1355 4'5"	1467 4'9"	1467 4'9"	1291 4'2"	1393 4'6"	1393 4'6"	67 2"
Reach at level lift arm and bucket level	mm ft/in	2682 8'9"	2843 9'3"	2843 9'3"	2722 8'11"	2883 9'5"	2883 9'5"	405 1'3"
Digging depth	mm in	97 3.8	97 3.8	67 2.6	97 3.8	97 3.8	67 2.6	21 0.8
Overall length	mm ft/in	8130 26'9"	8304 27'3"	8304 27'3"	8170 26'10"	8344 27'5"	8344 27'5"	652 2'2"
Overall height with bucket at maximum lift	mm ft/in	5468 18'0"	5468 18'0"	5468 18'0"	5539 18'3"	5539 18'3"	5539 18'3"	496 1'8"
Loader clearance circle with bucket at carry position	mm ft/in	6693 22'0"	6776 22'3"	6776 22'3"	6708 22'1"	6790 22'4"	6790 22'4"	391 1'4"
Static tipping load, straight (with tire deflection)*	kg lb	12 009 26,469	11 870 26,162	12 196 26,880	12 321 27,156	12 181 26,846	12 432 27,401	-776 -1712
Static tipping load, straight (no tire deflection)*	kg lb	12 689 27,967	12 548 27,657	12 884 28,398	13 002 28,657	12 860 28,345	13 116 28,907	-854 -1884
Static tipping load, articulated (with tire deflection)*	kg lb	10 340 22,790	10 201 22,483	10 510 23,164	10 652 23,477	10 511 23,167	10 747 23,687	-780 -1719
Static tipping load, articulated (no tire deflection)*	kg lb	11 026 24,301	10 885 23,991	11 204 24,694	11 339 24,992	11 197 24,680	11 437 25,207	-845 -1863
Breakout force	kN lbf	145 32,611	143 32,345	157 35,334	140 31,608	139 31,342	152 34,169	-8 -1939
Operating weight*	kg lb	18 614 41,025	18 722 41,263	18 565 40,917	18 216 40,148	18 324 40,386	18 167 40,040	1137 2505

\*Static tipping loads and operating weights shown are based on a machine configuration with Michelin 23.5R25 XHA2 L3 radial tires, full fluids, operator, cold start, roading fenders, Product Link, Open/Open axles (front/rear), power train guard, secondary steering and sound suppression.  
(With Tire Deflection) Full compliance to ISO 14397-1 (2007) Sections 1 thru 6, which requires 2% verification between calculations and testing.  
(No Tire Deflection) Compliance to ISO 14397-1 (2007) Sections 1 thru 5.

**NOTE:** Machine and bucket availability varies by region. Consult your local dealer for availability.

Bucket Type		General Purpose – Pin On		General Purpose – Hook On	High Lift Delta
		395-3265	395-3949	382-9835	
Bucket Part Number		Bolt-on Cutting Edges	Bolt-on Cutting Edges	Bolt-on Cutting Edges	
Edge Type					
Capacity – rated	m <sup>3</sup>	3.30	3.60	3.40	—
	yd <sup>3</sup>	<b>4.32</b>	<b>4.71</b>	<b>4.45</b>	—
Capacity – 110%	m <sup>3</sup>	3.63	3.96	3.74	—
	yd <sup>3</sup>	<b>4.75</b>	<b>5.18</b>	<b>4.89</b>	—
Width	mm	2927	2927	2927	—
	ft/in	<b>9'7"</b>	<b>9'7"</b>	<b>9'7"</b>	—
Dump clearance at maximum lift and 45° discharge	mm	2817	2745	2749	495
	ft/in	<b>9'2"</b>	<b>9'0"</b>	<b>9'0"</b>	<b>1'7"</b>
Reach at maximum lift and 45° discharge	mm	1349	1407	1407	67
	ft/in	<b>4'5"</b>	<b>4'7"</b>	<b>4'7"</b>	<b>2"</b>
Reach at level lift arm and bucket level	mm	2677	2772	2767	405
	ft/in	<b>8'9"</b>	<b>9'1"</b>	<b>9'0"</b>	<b>1'3"</b>
Digging depth	mm	89	89	97	21
	in	<b>3.5</b>	<b>3.5</b>	<b>3.8</b>	<b>0.8</b>
Overall length	mm	8269	8364	8365	652
	ft/in	<b>27'2"</b>	<b>27'6"</b>	<b>27'6"</b>	<b>2'2"</b>
Overall height with bucket at maximum lift	mm	5500	5587	5548	496
	ft/in	<b>18'1"</b>	<b>18'4"</b>	<b>18'3"</b>	<b>1'8"</b>
Loader clearance circle with bucket at carry position	mm	6692	6718	6717	391
	ft/in	<b>22'0"</b>	<b>22'1"</b>	<b>22'1"</b>	<b>1'4"</b>
Static tipping load, straight (with tire deflection)*	kg	13 611	13 425	12 924	-776
	lb	<b>29,999</b>	<b>29,590</b>	<b>28,486</b>	<b>-1712</b>
Static tipping load, straight (no tire deflection)*	kg	14 382	14 201	13 682	-854
	lb	<b>31,698</b>	<b>31,299</b>	<b>30,157</b>	<b>-1884</b>
Static tipping load, articulated (with tire deflection)*	kg	11 733	11 558	11 078	-780
	lb	<b>25,860</b>	<b>25,474</b>	<b>24,417</b>	<b>-1719</b>
Static tipping load, articulated (no tire deflection)*	kg	12 513	12 342	11 846	-845
	lb	<b>27,579</b>	<b>27,203</b>	<b>26,109</b>	<b>-1863</b>
Breakout force	kN	146	135	135	-8
	lbf	<b>32,804</b>	<b>30,414</b>	<b>30,480</b>	<b>-1939</b>
Operating weight*	kg	18 680	18 768	19 189	1137
	lb	<b>41,170</b>	<b>41,364</b>	<b>42,292</b>	<b>2505</b>

\*Static tipping loads and operating weights shown are based on a machine configuration with Michelin 23.5R25 XHA2 L3 radial tires, full fluids, operator, cold start, roading fenders, Product Link, Open/Open axles (front/rear), power train guard, secondary steering and sound suppression.  
(With Tire Deflection) Full compliance to ISO 14397-1 (2007) Sections 1 thru 6, which requires 2% verification between calculations and testing.  
(No Tire Deflection) Compliance to ISO 14397-1 (2007) Sections 1 thru 5.

**NOTE:** Machine and bucket availability varies by region. Consult your local dealer for availability.

Bucket Type	General Purpose — Pin On						High Lift Delta	
	Bucket Part Number	354-4849	354-4849	354-4849	354-4851	354-4851		354-4851
Edge Type		Bolt-on Cutting Edges	Teeth & Segments	Tips	Bolt-on Cutting Edges	Teeth & Segments	Tips	
Capacity — rated	m <sup>3</sup>	2.70	2.70	2.50	2.90	2.90	2.70	—
	yd <sup>3</sup>	3.53	3.53	3.27	3.79	3.79	3.53	—
Capacity — 110%	m <sup>3</sup>	2.97	2.97	2.75	3.19	3.19	2.97	—
	yd <sup>3</sup>	3.88	3.88	3.60	4.17	4.17	3.88	—
Width	mm	2927	2994	2994	2927	2994	2994	—
	ft/in	9'7"	9'9"	9'9"	9'7"	9'9"	9'9"	—
Dump clearance at maximum lift and 45° discharge	mm	3191	3076	3076	3136	3019	3019	289
	ft/in	10'5"	10'1"	10'1"	10'3"	9'10"	9'10"	11"
Reach at maximum lift and 45° discharge	mm	1290	1403	1403	1328	1440	1440	101
	ft/in	4'2"	4'7"	4'7"	4'4"	4'8"	4'8"	3"
Reach at level lift arm and bucket level	mm	2660	2821	2821	2729	2890	2890	277
	ft/in	8'8"	9'3"	9'3"	8'11"	9'5"	9'5"	10"
Digging depth	mm	88	88	58	88	88	58	6
	in	3.5	3.5	2.3	3.5	3.5	2.3	0
Overall length	mm	8399	8571	8571	8468	8640	8640	372
	ft/in	27'7"	28'2"	28'2"	27'10"	28'5"	28'5"	1'2"
Overall height with bucket at maximum lift	mm	5609	5609	5609	5681	5681	5681	288
	ft/in	18'5"	18'5"	18'5"	18'8"	18'8"	18'8"	11"
Loader clearance circle with bucket at carry position	mm	13 785	13 953	13 953	13 825	13 995	13 995	308
	ft/in	45'3"	45'10"	45'10"	45'5"	45'11"	45'11"	1'0"
Static tipping load, straight (with tire deflection)*	kg	14 054	13 917	14 225	13 905	13 766	14 068	-631
	lb	30,975	30,673	31,353	30,647	30,342	31,006	-1391
Static tipping load, straight (no tire deflection)*	kg	14 787	14 649	14 966	14 641	14 502	14 811	-722
	lb	32,591	32,286	32,986	32,270	31,962	32,644	-1592
Static tipping load, articulated (with tire deflection)*	kg	12 066	11 929	12 217	11 923	11 785	12 066	-612
	lb	26,594	26,292	26,926	26,280	25,975	26,595	-1349
Static tipping load, articulated (no tire deflection)*	kg	12 820	12 682	12 978	12 681	12 541	12 830	-695
	lb	28,256	27,952	28,604	27,950	27,642	28,278	-1532
Breakout force	kN	219	218	241	206	205	225	-2
	lbf	49,349	49,114	54,147	46,405	46,170	50,653	-4
Operating weight*	kg	20 036	20 144	19 987	20 120	20 228	20 071	592
	lb	44,158	44,396	44,050	44,345	44,583	44,237	1305

\*Static tipping loads and operating weights shown are based on a machine configuration with Michelin 23.5R25 XHA2 L3 radial tires, full fluids, operator, cold start, roading fenders, Product Link, Manual Diff Lock/Open axles (front/rear), power train guard, secondary steering and sound suppression. (With Tire Deflection) Full compliance to ISO 14397-1 (2007) Sections 1 thru 6, which requires 2% verification between calculations and testing. (No Tire Deflection) Compliance to ISO 14397-1 (2007) Sections 1 thru 5.

**NOTE:** Machine and bucket availability varies by region. Consult your local dealer for availability.

Bucket Type	General Purpose — Pin On							High Lift Delta
	Bucket Part Number	352-5537	352-5537	352-5537	352-5538	352-5538	352-5538	
Edge Type		Bolt-on Cutting Edges	Teeth & Segments	Tips	Bolt-on Cutting Edges	Teeth & Segments	Tips	
Capacity — rated	m <sup>3</sup>	3.10	3.10	2.90	3.30	3.30	3.10	—
	yd <sup>3</sup>	<b>4.05</b>	<b>4.05</b>	<b>3.79</b>	<b>4.32</b>	<b>4.32</b>	<b>4.05</b>	—
Capacity — 110%	m <sup>3</sup>	3.41	3.41	3.19	3.63	3.63	3.41	—
	yd <sup>3</sup>	<b>4.46</b>	<b>4.46</b>	<b>4.17</b>	<b>4.75</b>	<b>4.75</b>	<b>4.46</b>	—
Width	mm	2927	2994	2994	2927	2994	2994	—
	ft/in	<b>9'7"</b>	<b>9'9"</b>	<b>9'9"</b>	<b>9'7"</b>	<b>9'9"</b>	<b>9'9"</b>	—
Dump clearance at maximum lift and 45° discharge	mm	3093	2975	2975	3054	2936	2936	289
	ft/in	<b>10'1"</b>	<b>9'9"</b>	<b>9'9"</b>	<b>10'0"</b>	<b>9'7"</b>	<b>9'7"</b>	<b>11"</b>
Reach at maximum lift and 45° discharge	mm	1363	1474	1474	1392	1502	1502	101
	ft/in	<b>4'5"</b>	<b>4'10"</b>	<b>4'10"</b>	<b>4'6"</b>	<b>4'11"</b>	<b>4'11"</b>	<b>3"</b>
Reach at level lift arm and bucket level	mm	2786	2947	2947	2835	2996	2996	277
	ft/in	<b>9'1"</b>	<b>9'8"</b>	<b>9'8"</b>	<b>9'3"</b>	<b>9'9"</b>	<b>9'9"</b>	<b>10"</b>
Digging depth	mm	88	88	58	88	88	58	6
	in	<b>3.5</b>	<b>3.5</b>	<b>2.3</b>	<b>3.5</b>	<b>3.5</b>	<b>2.3</b>	<b>0</b>
Overall length	mm	8525	8697	8697	8574	8746	8746	372
	ft/in	<b>28'0"</b>	<b>28'7"</b>	<b>28'7"</b>	<b>28'2"</b>	<b>28'9"</b>	<b>28'9"</b>	<b>1'2"</b>
Overall height with bucket at maximum lift	mm	5742	5742	5742	5788	5788	5788	288
	ft/in	<b>18'11"</b>	<b>18'11"</b>	<b>18'11"</b>	<b>19'0"</b>	<b>19'0"</b>	<b>19'0"</b>	<b>11"</b>
Loader clearance circle with bucket at carry position	mm	13 859	14 029	14 029	13 888	14 059	14 059	308
	ft/in	<b>45'6"</b>	<b>46'1"</b>	<b>46'1"</b>	<b>45'7"</b>	<b>46'2"</b>	<b>46'2"</b>	<b>1'0"</b>
Static tipping load, straight (with tire deflection)*	kg	13 803	13 664	13 957	13 677	13 536	13 828	-631
	lb	<b>30,423</b>	<b>30,116</b>	<b>30,763</b>	<b>30,144</b>	<b>29,834</b>	<b>30,477</b>	<b>-1391</b>
Static tipping load, straight (no tire deflection)*	kg	14 543	14 402	14 703	14 418	14 276	14 575	-722
	lb	<b>32,053</b>	<b>31,743</b>	<b>32,406</b>	<b>31,777</b>	<b>31,465</b>	<b>32,124</b>	<b>-1592</b>
Static tipping load, articulated (with tire deflection)*	kg	11 829	11 690	11 964	11 709	11 568	11 840	-612
	lb	<b>26,072</b>	<b>25,765</b>	<b>26,369</b>	<b>25,806</b>	<b>25,497</b>	<b>26,097</b>	<b>-1349</b>
Static tipping load, articulated (no tire deflection)*	kg	12 590	12 449	12 730	12 471	12 329	12 608	-695
	lb	<b>27,749</b>	<b>27,439</b>	<b>28,057</b>	<b>27,486</b>	<b>27,174</b>	<b>27,789</b>	<b>-1532</b>
Breakout force	kN	196	195	214	189	188	204	-2
	lbf	<b>44,238</b>	<b>44,003</b>	<b>48,103</b>	<b>42,483</b>	<b>42,248</b>	<b>46,055</b>	<b>-4</b>
Operating weight*	kg	20 157	20 265	20 108	20 227	20 335	20 178	592
	lb	<b>44,426</b>	<b>44,664</b>	<b>44,318</b>	<b>44,579</b>	<b>44,817</b>	<b>44,471</b>	<b>1305</b>

\*Static tipping loads and operating weights shown are based on a machine configuration with Michelin 23.5R25 XHA2 L3 radial tires, full fluids, operator, cold start, roading fenders, Product Link, Manual Diff Lock/Open axles (front/rear), power train guard, secondary steering and sound suppression. (With Tire Deflection) Full compliance to ISO 14397-1 (2007) Sections 1 thru 6, which requires 2% verification between calculations and testing. (No Tire Deflection) Compliance to ISO 14397-1 (2007) Sections 1 thru 5.

**NOTE:** Machine and bucket availability varies by region. Consult your local dealer for availability.

Bucket Type	General Purpose — Pin On							High Lift Delta
	Bucket Part Number	354-4853	354-4853	354-4853	354-4855	354-4855	354-4855	
Edge Type		Bolt-on Cutting Edges	Teeth & Segments	Tips	Bolt-on Cutting Edges	Teeth & Segments	Tips	
Capacity — rated	m <sup>3</sup>	3.40	3.40	3.20	3.60	3.60	3.40	—
	yd <sup>3</sup>	4.45	4.45	4.19	4.71	4.71	4.45	—
Capacity — 110%	m <sup>3</sup>	3.74	3.74	3.52	3.96	3.96	3.74	—
	yd <sup>3</sup>	4.89	4.89	4.60	5.18	5.18	4.89	—
Width	mm	2927	2994	2994	2927	2994	2994	—
	ft/in	9'7"	9'9"	9'9"	9'7"	9'9"	9'9"	—
Dump clearance at maximum lift and 45° discharge	mm	3036	2917	2917	3010	2890	2890	289
	ft/in	9'11"	9'6"	9'6"	9'10"	9'5"	9'5"	11"
Reach at maximum lift and 45° discharge	mm	1406	1516	1516	1428	1537	1537	101
	ft/in	4'7"	4'11"	4'11"	4'8"	5'0"	5'0"	3"
Reach at level lift arm and bucket level	mm	2859	3020	3020	2894	3055	3055	277
	ft/in	9'4"	9'10"	9'10"	9'5"	10'0"	10'0"	10"
Digging depth	mm	88	88	58	88	88	58	6
	in	3.5	3.5	2.3	3.5	3.5	2.3	0
Overall length	mm	8598	8770	8770	8633	8805	8805	372
	ft/in	28'3"	28'10"	28'10"	28'4"	28'11"	28'11"	1'2"
Overall height with bucket at maximum lift	mm	5813	5813	5813	5847	5847	5847	288
	ft/in	19'1"	19'1"	19'1"	19'3"	19'3"	19'3"	11"
Loader clearance circle with bucket at carry position	mm	13 903	14 074	14 074	13 924	14 095	14 095	308
	ft/in	45'8"	46'3"	46'3"	45'9"	46'3"	46'3"	1'0"
Static tipping load, straight (with tire deflection)*	kg	13 630	13 490	13 778	13 555	13 414	13 699	-631
	lb	30,042	29,732	30,368	29,877	29,565	30,193	-1391
Static tipping load, straight (no tire deflection)*	kg	14 373	14 231	14 526	14 299	14 156	14 448	-722
	lb	31,678	31,365	32,016	31,516	31,201	31,845	-1592
Static tipping load, articulated (with tire deflection)*	kg	11 665	11 524	11 793	11 594	11 452	11 718	-612
	lb	25,709	25,399	25,993	25,553	25,241	25,828	-1349
Static tipping load, articulated (no tire deflection)*	kg	12 428	12 286	12 562	12 359	12 216	12 488	-695
	lb	27,392	27,079	27,687	27,239	26,924	27,524	-1532
Breakout force	kN	185	184	200	180	179	195	-2
	lbf	41,675	41,440	45,117	40,547	40,311	43,810	-4
Operating weight*	kg	20 251	20 359	20 202	20 287	20 395	20 238	592
	lb	44,632	44,870	44,524	44,712	44,950	44,604	1305

\*Static tipping loads and operating weights shown are based on a machine configuration with Michelin 23.5R25 XHA2 L3 radial tires, full fluids, operator, cold start, roading fenders, Product Link, Manual Diff Lock/Open axles (front/rear), power train guard, secondary steering and sound suppression. (With Tire Deflection) Full compliance to ISO 14397-1 (2007) Sections 1 thru 6, which requires 2% verification between calculations and testing. (No Tire Deflection) Compliance to ISO 14397-1 (2007) Sections 1 thru 5.

**NOTE:** Machine and bucket availability varies by region. Consult your local dealer for availability.

Bucket Type	General Purpose — Pin On			Material Handling — Pin On			High Lift Delta	
Bucket Part Number	376-7800	376-7800	376-7800	354-4857	354-4857	354-4857		
Edge Type	Bolt-on Cutting Edges	Teeth & Segments	Tips	Bolt-on Cutting Edges	Teeth & Segments	Tips		
Capacity — rated	m <sup>3</sup> yd <sup>3</sup>	3.80 4.97	3.80 4.97	3.60 4.71	2.70 3.53	2.70 3.53	2.50 3.27	— —
Capacity — 110%	m <sup>3</sup> yd <sup>3</sup>	4.18 5.47	4.18 5.47	3.96 5.18	2.97 3.88	2.97 3.88	2.75 3.60	— —
Width	mm ft/in	2927 9'7"	2994 9'9"	2994 9'9"	2927 9'7"	2994 9'9"	2994 9'9"	— —
Dump clearance at maximum lift and 45° discharge	mm ft/in	2975 9'9"	2855 9'4"	2855 9'4"	3112 10'2"	2987 9'9"	2987 9'9"	289 11"
Reach at maximum lift and 45° discharge	mm ft/in	1457 4'9"	1566 5'1"	1566 5'1"	1206 3'11"	1308 4'3"	1308 4'3"	101 3"
Reach at level lift arm and bucket level	mm ft/in	2940 9'7"	3101 10'2"	3101 10'2"	2679 8'9"	2840 9'3"	2840 9'3"	277 10"
Digging depth	mm in	88 3.5	88 3.5	58 2.3	88 3.5	88 3.5	58 2.3	6 0
Overall length	mm ft/in	8679 28'6"	8851 29'1"	8851 29'1"	8418 27'8"	8590 28'3"	8590 28'3"	372 1'2"
Overall height with bucket at maximum lift	mm ft/in	5894 19'5"	5894 19'5"	5894 19'5"	5835 19'2"	5835 19'2"	5835 19'2"	288 11"
Loader clearance circle with bucket at carry position	mm ft/in	13 952 45'10"	14 124 46'5"	14 124 46'5"	13 796 45'4"	13 965 45'10"	13 965 45'10"	308 1'0"
Static tipping load, straight (with tire deflection)*	kg lb	13 450 29,644	13 308 29,330	13 588 29,949	13 879 30,591	13 743 30,291	14 078 31,029	-631 -1391
Static tipping load, straight (no tire deflection)*	kg lb	14 195 31,287	14 052 30,970	14 339 31,604	14 596 32,170	14 459 31,868	14 804 32,628	-722 -1592
Static tipping load, articulated (with tire deflection)*	kg lb	11 494 25,333	11 352 25,019	11 613 25,597	11 912 26,255	11 776 25,955	12 092 26,651	-612 -1349
Static tipping load, articulated (no tire deflection)*	kg lb	12 260 27,023	12 117 26,706	12 385 27,296	12 650 27,882	12 513 27,579	12 838 28,297	-695 -1532
Breakout force	kN lbf	174 39,140	173 38,905	187 42,189	215 48,485	214 48,250	236 53,119	-2 -4
Operating weight*	kg lb	20 342 44,832	20 450 45,070	20 293 44,724	20 058 44,208	20 166 44,446	20 009 44,100	592 1305

\*Static tipping loads and operating weights shown are based on a machine configuration with Michelin 23.5R25 XHA2 L3 radial tires, full fluids, operator, cold start, roading fenders, Product Link, Manual Diff Lock/Open axles (front/rear), power train guard, secondary steering and sound suppression. (With Tire Deflection) Full compliance to ISO 14397-1 (2007) Sections 1 thru 6, which requires 2% verification between calculations and testing. (No Tire Deflection) Compliance to ISO 14397-1 (2007) Sections 1 thru 5.

**NOTE:** Machine and bucket availability varies by region. Consult your local dealer for availability.

Bucket Type Bucket Part Number	Material Handling — Pin On						High Lift Delta	
	354-4859	354-4859	354-4859	354-4861	354-4861	354-4861		
Edge Type	Bolt-on Cutting Edges	Teeth & Segments	Tips	Bolt-on Cutting Edges	Teeth & Segments	Tips		
Capacity — rated	m <sup>3</sup> yd <sup>3</sup>	2.90 3.79	2.90 3.79	2.70 3.53	3.10 4.05	3.10 4.05	2.90 3.79	— —
Capacity — 110%	m <sup>3</sup> yd <sup>3</sup>	3.19 4.17	3.19 4.17	2.97 3.88	3.41 4.46	3.41 4.46	3.19 4.17	— —
Width	mm ft/in	2927 9'7"	2994 9'9"	2994 9'9"	2927 9'7"	2994 9'9"	2994 9'9"	— —
Dump clearance at maximum lift and 45° discharge	mm ft/in	3070 10'0"	2944 9'7"	2944 9'7"	3038 9'11"	2913 9'6"	2913 9'6"	289 11"
Reach at maximum lift and 45° discharge	mm ft/in	1248 4'1"	1350 4'5"	1350 4'5"	1280 4'2"	1382 4'6"	1382 4'6"	101 3"
Reach at level lift arm and bucket level	mm ft/in	2739 9'11"	2900 9'6"	2900 9'6"	2784 9'1"	2945 9'7"	2945 9'7"	277 10"
Digging depth	mm in	88 3.5	88 3.5	58 2.3	88 3.5	88 3.5	58 2.3	6 0
Overall length	mm ft/in	8478 27'10"	8650 28'5"	8650 28'5"	8523 28'0"	8695 28'7"	8695 28'7"	372 1'2"
Overall height with bucket at maximum lift	mm ft/in	5192 17'1"	5192 17'1"	5192 17'1"	5700 18'9"	5700 18'9"	5700 18'9"	288 11"
Loader clearance circle with bucket at carry position	mm ft/in	13 831 45'5"	14 001 46'0"	14 001 46'0"	13 858 45'6"	14 028 46'1"	14 028 46'1"	308 1'0"
Static tipping load, straight (with tire deflection)*	kg lb	13 756 30,319	13 619 30,016	13 913 30,664	13 658 30,102	13 519 29,797	13 807 30,432	-631 -1391
Static tipping load, straight (no tire deflection)*	kg lb	14 475 31,904	14 337 31,599	14 637 32,261	14 378 31,690	14 239 31,383	14 533 32,032	-722 -1592
Static tipping load, articulated (with tire deflection)*	kg lb	11 796 26,000	11 659 25,697	11 934 26,304	11 703 25,794	11 565 25,490	11 835 26,084	-612 -1349
Static tipping load, articulated (no tire deflection)*	kg lb	12 537 27,632	12 398 27,327	12 680 27,946	12 445 27,430	12 306 27,123	12 582 27,730	-695 -1532
Breakout force	kN lbf	204 46,006	203 45,771	223 50,183	197 44,283	196 44,048	214 48,158	-2 -4
Operating weight*	kg lb	20 114 44,331	20 222 44,569	20 065 44,223	20 164 44,442	20 272 44,680	20 115 44,334	592 1305

\*Static tipping loads and operating weights shown are based on a machine configuration with Michelin 23.5R25 XHA2 L3 radial tires, full fluids, operator, cold start, roading fenders, Product Link, Manual Diff Lock/Open axles (front/rear), power train guard, secondary steering and sound suppression. (With Tire Deflection) Full compliance to ISO 14397-1 (2007) Sections 1 thru 6, which requires 2% verification between calculations and testing. (No Tire Deflection) Compliance to ISO 14397-1 (2007) Sections 1 thru 5.

**NOTE:** Machine and bucket availability varies by region. Consult your local dealer for availability.



Bucket Type	Material Handling — Pin On							High Lift Delta
	Bucket Part Number	354-4863	354-4863	354-4863	354-4865	354-4865	354-4865	
Edge Type		Bolt-on Cutting Edges	Teeth & Segments	Tips	Bolt-on Cutting Edges	Teeth & Segments	Tips	
Capacity — rated	m <sup>3</sup>	3.30	3.30	3.10	3.40	3.40	3.20	—
	yd <sup>3</sup>	<b>4.32</b>	<b>4.32</b>	<b>4.05</b>	<b>4.45</b>	<b>4.45</b>	<b>4.19</b>	—
Capacity — 110%	m <sup>3</sup>	3.63	3.63	3.41	3.74	3.74	3.52	—
	yd <sup>3</sup>	<b>4.75</b>	<b>4.75</b>	<b>4.46</b>	<b>4.89</b>	<b>4.89</b>	<b>4.60</b>	—
Width	mm	2927	2994	2994	2927	2994	2994	—
	ft/in	<b>9'7"</b>	<b>9'9"</b>	<b>9'9"</b>	<b>9'7"</b>	<b>9'9"</b>	<b>9'9"</b>	—
Dump clearance at maximum lift and 45° discharge	mm	3006	2881	2881	2978	2852	2852	289
	ft/in	<b>9'10"</b>	<b>9'5"</b>	<b>9'5"</b>	<b>9'9"</b>	<b>9'4"</b>	<b>9'4"</b>	<b>11"</b>
Reach at maximum lift and 45° discharge	mm	1312	1414	1414	1340	1442	1442	101
	ft/in	<b>4'3"</b>	<b>4'7"</b>	<b>4'7"</b>	<b>4'4"</b>	<b>4'8"</b>	<b>4'8"</b>	<b>3"</b>
Reach at level lift arm and bucket level	mm	2829	2990	2990	2869	3030	3030	277
	ft/in	<b>9'3"</b>	<b>9'9"</b>	<b>9'9"</b>	<b>9'4"</b>	<b>9'11"</b>	<b>9'11"</b>	<b>10"</b>
Digging depth	mm	88	88	58	88	88	58	6
	in	<b>3.5</b>	<b>3.5</b>	<b>2.3</b>	<b>3.5</b>	<b>3.5</b>	<b>2.3</b>	<b>0</b>
Overall length	mm	8568	8740	8740	8608	8780	8780	372
	ft/in	<b>28'2"</b>	<b>28'9"</b>	<b>28'9"</b>	<b>28'3"</b>	<b>28'10"</b>	<b>28'10"</b>	<b>1'2"</b>
Overall height with bucket at maximum lift	mm	5744	5744	5744	5783	5783	5783	288
	ft/in	<b>18'11"</b>	<b>18'11"</b>	<b>18'11"</b>	<b>19'0"</b>	<b>19'0"</b>	<b>19'0"</b>	<b>11"</b>
Loader clearance circle with bucket at carry position	mm	13 885	14 055	14 055	13 909	14 080	14 080	308
	ft/in	<b>45'7"</b>	<b>46'2"</b>	<b>46'2"</b>	<b>45'8"</b>	<b>46'3"</b>	<b>46'3"</b>	<b>1'0"</b>
Static tipping load, straight (with tire deflection)*	kg	13 560	13 422	13 706	13 477	13 337	13 618	-631
	lb	<b>29,888</b>	<b>29,582</b>	<b>30,209</b>	<b>29,704</b>	<b>29,396</b>	<b>30,016</b>	<b>-1391</b>
Static tipping load, straight (no tire deflection)*	kg	14 283	14 143	14 434	14 201	14 060	14 347	-722
	lb	<b>31,480</b>	<b>31,171</b>	<b>31,812</b>	<b>31,299</b>	<b>30,989</b>	<b>31,622</b>	<b>-1592</b>
Static tipping load, articulated (with tire deflection)*	kg	11 611	11 472	11 739	11 533	11 393	11 656	-612
	lb	<b>25,592</b>	<b>25,286</b>	<b>25,873</b>	<b>25,418</b>	<b>25,111</b>	<b>25,691</b>	<b>-1349</b>
Static tipping load, articulated (no tire deflection)*	kg	12 356	12 215	12 487	12 278	12 137	12 406	-695
	lb	<b>27,232</b>	<b>26,924</b>	<b>27,523</b>	<b>27,062</b>	<b>26,751</b>	<b>27,343</b>	<b>-1532</b>
Breakout force	kN	189	188	206	183	182	199	-2
	lbf	<b>42,676</b>	<b>42,441</b>	<b>46,282</b>	<b>41,337</b>	<b>41,102</b>	<b>44,726</b>	<b>-4</b>
Operating weight*	kg	20 212	20 320	20 163	20 252	20 360	20 203	592
	lb	<b>44,547</b>	<b>44,785</b>	<b>44,439</b>	<b>44,636</b>	<b>44,874</b>	<b>44,528</b>	<b>1305</b>

\*Static tipping loads and operating weights shown are based on a machine configuration with Michelin 23.5R25 XHA2 L3 radial tires, full fluids, operator, cold start, roading fenders, Product Link, Manual Diff Lock/Open axles (front/rear), power train guard, secondary steering and sound suppression. (With Tire Deflection) Full compliance to ISO 14397-1 (2007) Sections 1 thru 6, which requires 2% verification between calculations and testing. (No Tire Deflection) Compliance to ISO 14397-1 (2007) Sections 1 thru 5.

**NOTE:** Machine and bucket availability varies by region. Consult your local dealer for availability.

Bucket Type Bucket Part Number	Material Handling — Pin On						High Lift Delta	
	367-5733	367-5733	367-5733	354-4867	354-4867	354-4867		
Edge Type	Bolt-on Cutting Edges	Teeth & Segments	Tips	Bolt-on Cutting Edges	Teeth & Segments	Tips		
Capacity — rated	m <sup>3</sup> yd <sup>3</sup>	3.60 4.71	3.60 4.71	3.40 4.45	3.80 4.97	3.80 4.97	3.60 4.71	— —
Capacity — 110%	m <sup>3</sup> yd <sup>3</sup>	3.96 5.18	3.96 5.18	3.74 4.89	4.18 5.47	4.18 5.47	3.96 5.18	— —
Width	mm ft/in	2927 9'7"	2994 9'9"	2994 9'9"	2927 9'7"	2994 9'9"	2994 9'9"	— —
Dump clearance at maximum lift and 45° discharge	mm ft/in	2946 9'8"	2821 9'3"	2821 9'3"	2910 9'6"	2785 9'1"	2785 9'1"	289 11"
Reach at maximum lift and 45° discharge	mm ft/in	1372 4'6"	1474 4'10"	1474 4'10"	1408 4'7"	1510 4'11"	1510 4'11"	101 3"
Reach at level lift arm and bucket level	mm ft/in	2914 9'6"	3075 10'1"	3075 10'1"	2965 9'8"	3126 10'3"	3126 10'3"	277 10"
Digging depth	mm in	88 3.5	88 3.5	58 2.3	88 3.5	88 3.5	58 2.3	6 0
Overall length	mm ft/in	8653 28'5"	8825 29'0"	8825 29'0"	8704 28'7"	8876 29'2"	8876 29'2"	372 1'2"
Overall height with bucket at maximum lift	mm ft/in	5831 19'2"	5831 19'2"	5831 19'2"	5879 19'4"	5879 19'4"	5879 19'4"	288 11"
Loader clearance circle with bucket at carry position	mm ft/in	13 936 45'9"	14 108 46'4"	14 108 46'4"	13 967 45'10"	14 139 46'5"	14 139 46'5"	308 1'0"
Static tipping load, straight (with tire deflection)*	kg lb	13 383 29,498	13 243 29,188	13 520 29,799	13 275 29,258	13 134 28,947	13 407 29,550	-631 -1391
Static tipping load, straight (no tire deflection)*	kg lb	14 109 31,097	13 967 30,785	14 250 31,408	14 002 30,861	13 860 30,547	14 139 31,162	-722 -1592
Static tipping load, articulated (with tire deflection)*	kg lb	11 445 25,225	11 304 24,915	11 564 25,487	11 342 24,998	11 201 24,687	11 456 25,250	-612 -1349
Static tipping load, articulated (no tire deflection)*	kg lb	12 192 26,871	12 050 26,559	12 315 27,142	12 091 26,649	11 948 26,335	12 209 26,909	-695 -1532
Breakout force	kN lbf	177 39,919	176 39,684	191 43,087	170 38,410	169 38,174	184 41,351	-2 -4
Operating weight*	kg lb	20 296 44,732	20 404 44,970	20 247 44,624	20 350 44,851	20 458 45,089	20 301 44,743	592 1305

\*Static tipping loads and operating weights shown are based on a machine configuration with Michelin 23.5R25 XHA2 L3 radial tires, full fluids, operator, cold start, roading fenders, Product Link, Manual Diff Lock/Open axles (front/rear), power train guard, secondary steering and sound suppression. (With Tire Deflection) Full compliance to ISO 14397-1 (2007) Sections 1 thru 6, which requires 2% verification between calculations and testing. (No Tire Deflection) Compliance to ISO 14397-1 (2007) Sections 1 thru 5.

**NOTE:** Machine and bucket availability varies by region. Consult your local dealer for availability.

Bucket Type	General Purpose — Hook On							High Lift Delta
	Bucket Part Number	354-4850	354-4850	354-4850	354-4852	354-4852	354-4852	
Edge Type		Bolt-on Cutting Edges	Teeth & Segments	Tips	Bolt-on Cutting Edges	Teeth & Segments	Tips	
Capacity — rated	m <sup>3</sup>	2.70	2.70	2.50	2.90	2.90	2.70	—
	yd <sup>3</sup>	<b>3.53</b>	<b>3.53</b>	<b>3.27</b>	<b>3.79</b>	<b>3.79</b>	<b>3.53</b>	—
Capacity — 110%	m <sup>3</sup>	2.97	2.97	2.75	3.19	3.19	2.97	—
	yd <sup>3</sup>	<b>3.88</b>	<b>3.88</b>	<b>3.60</b>	<b>4.17</b>	<b>4.17</b>	<b>3.88</b>	—
Width	mm	2927	2994	2994	2927	2994	2994	—
	ft/in	<b>9'7"</b>	<b>9'9"</b>	<b>9'9"</b>	<b>9'7"</b>	<b>9'9"</b>	<b>9'9"</b>	—
Dump clearance at maximum lift and 45° discharge	mm	3153	3037	3037	3097	2980	2980	289
	ft/in	<b>10'4"</b>	<b>9'11"</b>	<b>9'11"</b>	<b>10'1"</b>	<b>9'9"</b>	<b>9'9"</b>	<b>11"</b>
Reach at maximum lift and 45° discharge	mm	1336	1449	1449	1374	1485	1485	101
	ft/in	<b>4'4"</b>	<b>4'9"</b>	<b>4'9"</b>	<b>4'6"</b>	<b>4'10"</b>	<b>4'10"</b>	<b>3"</b>
Reach at level lift arm and bucket level	mm	2720	2881	2881	2789	2950	2950	277
	ft/in	<b>8'11"</b>	<b>9'5"</b>	<b>9'5"</b>	<b>9'1"</b>	<b>9'8"</b>	<b>9'8"</b>	<b>10"</b>
Digging depth	mm	88	88	58	88	88	58	6
	in	<b>3.5</b>	<b>3.5</b>	<b>2.3</b>	<b>3.5</b>	<b>3.5</b>	<b>2.3</b>	<b>0</b>
Overall length	mm	8459	8631	8631	8528	8700	8700	372
	ft/in	<b>27'10"</b>	<b>28'4"</b>	<b>28'4"</b>	<b>28'0"</b>	<b>28'7"</b>	<b>28'7"</b>	<b>1'2"</b>
Overall height with bucket at maximum lift	mm	5641	5641	5641	5714	5714	5714	288
	ft/in	<b>18'7"</b>	<b>18'7"</b>	<b>18'7"</b>	<b>18'9"</b>	<b>18'9"</b>	<b>18'9"</b>	<b>11"</b>
Loader clearance circle with bucket at carry position	mm	13 811	13 982	13 982	13 852	14 024	14 024	308
	ft/in	<b>45'4"</b>	<b>45'11"</b>	<b>45'11"</b>	<b>45'6"</b>	<b>46'1"</b>	<b>46'1"</b>	<b>1'0"</b>
Static tipping load, straight (with tire deflection)*	kg	13 441	13 305	13 645	13 320	13 182	13 519	-631
	lb	<b>29,625</b>	<b>29,324</b>	<b>30,075</b>	<b>29,357</b>	<b>29,053</b>	<b>29,796</b>	<b>-1391</b>
Static tipping load, straight (no tire deflection)*	kg	14 165	14 027	14 380	14 046	13 907	14 256	-722
	lb	<b>31,219</b>	<b>30,916</b>	<b>31,693</b>	<b>30,958</b>	<b>30,651</b>	<b>31,421</b>	<b>-1592</b>
Static tipping load, articulated (with tire deflection)*	kg	11 483	11 346	11 666	11 368	11 230	11 547	-612
	lb	<b>25,309</b>	<b>25,008</b>	<b>25,713</b>	<b>25,055</b>	<b>24,751</b>	<b>25,450</b>	<b>-1349</b>
Static tipping load, articulated (no tire deflection)*	kg	12 228	12 090	12 422	12 116	11 976	12 305	-695
	lb	<b>26,951</b>	<b>26,648</b>	<b>27,379</b>	<b>26,704</b>	<b>26,397</b>	<b>27,122</b>	<b>-1532</b>
Breakout force	kN	208	207	227	196	195	213	-2
	lbf	<b>46,777</b>	<b>46,543</b>	<b>51,093</b>	<b>44,122</b>	<b>43,887</b>	<b>47,968</b>	<b>-4</b>
Operating weight*	kg	20 510	20 618	20 461	20 573	20 681	20 524	592
	lb	<b>45,204</b>	<b>45,442</b>	<b>45,096</b>	<b>45,342</b>	<b>45,580</b>	<b>45,234</b>	<b>1305</b>

\*Static tipping loads and operating weights shown are based on a machine configuration with Michelin 23.5R25 XHA2 L3 radial tires, full fluids, operator, cold start, roading fenders, Product Link, Manual Diff Lock/Open axles (front/rear), power train guard, secondary steering and sound suppression. (With Tire Deflection) Full compliance to ISO 14397-1 (2007) Sections 1 thru 6, which requires 2% verification between calculations and testing. (No Tire Deflection) Compliance to ISO 14397-1 (2007) Sections 1 thru 5.

**NOTE:** Machine and bucket availability varies by region. Consult your local dealer for availability.

Bucket Type Bucket Part Number		General Purpose — Hook On						High Lift Delta
		348-0242	348-0242	348-0242	348-0243	348-0243	348-0243	
Edge Type		Bolt-on Cutting Edges	Teeth & Segments	Tips	Bolt-on Cutting Edges	Teeth & Segments	Tips	
Capacity — rated	m <sup>3</sup>	3.10	3.10	2.90	3.30	3.30	3.10	—
	yd <sup>3</sup>	<b>4.05</b>	<b>4.05</b>	<b>3.79</b>	<b>4.32</b>	<b>4.32</b>	<b>4.05</b>	—
Capacity — 110%	m <sup>3</sup>	3.41	3.41	3.19	3.63	3.63	3.41	—
	yd <sup>3</sup>	<b>4.46</b>	<b>4.46</b>	<b>4.17</b>	<b>4.75</b>	<b>4.75</b>	<b>4.46</b>	—
Width	mm	2927	2994	2994	2927	2994	2994	—
	ft/in	<b>9'7"</b>	<b>9'9"</b>	<b>9'9"</b>	<b>9'7"</b>	<b>9'9"</b>	<b>9'9"</b>	—
Dump clearance at maximum lift and 45° discharge	mm	3053	2935	2935	3015	2896	2896	289
	ft/in	<b>10'0"</b>	<b>9'7"</b>	<b>9'7"</b>	<b>9'10"</b>	<b>9'6"</b>	<b>9'6"</b>	<b>11"</b>
Reach at maximum lift and 45° discharge	mm	1408	1519	1519	1437	1547	1547	101
	ft/in	<b>4'7"</b>	<b>4'11"</b>	<b>4'11"</b>	<b>4'8"</b>	<b>5'0"</b>	<b>5'0"</b>	<b>3"</b>
Reach at level lift arm and bucket level	mm	2846	3007	3007	2895	3056	3056	277
	ft/in	<b>9'4"</b>	<b>9'10"</b>	<b>9'10"</b>	<b>9'5"</b>	<b>10'0"</b>	<b>10'0"</b>	<b>10"</b>
Digging depth	mm	88	88	58	88	88	58	6
	in	<b>3.5</b>	<b>3.5</b>	<b>2.3</b>	<b>3.5</b>	<b>3.5</b>	<b>2.3</b>	<b>0</b>
Overall length	mm	8585	8757	8757	8634	8806	8806	372
	ft/in	<b>28'2"</b>	<b>28'9"</b>	<b>28'9"</b>	<b>28'4"</b>	<b>28'11"</b>	<b>28'11"</b>	<b>1'2"</b>
Overall height with bucket at maximum lift	mm	5775	5775	5775	5821	5821	5821	288
	ft/in	<b>19'0"</b>	<b>19'0"</b>	<b>19'0"</b>	<b>19'2"</b>	<b>19'2"</b>	<b>19'2"</b>	<b>11"</b>
Loader clearance circle with bucket at carry position	mm	13 887	14 060	14 060	13 917	14 090	14 090	308
	ft/in	<b>45'7"</b>	<b>46'2"</b>	<b>46'2"</b>	<b>45'8"</b>	<b>46'3"</b>	<b>46'3"</b>	<b>1'0"</b>
Static tipping load, straight (with tire deflection)*	kg	13 202	13 063	13 399	13 105	12 965	13 300	-631
	lb	<b>29,097</b>	<b>28,791</b>	<b>29,531</b>	<b>28,885</b>	<b>28,576</b>	<b>29,313</b>	<b>-1391</b>
Static tipping load, straight (no tire deflection)*	kg	13 931	13 791	14 138	13 836	13 695	14 041	-722
	lb	<b>30,704</b>	<b>30,395</b>	<b>31,161</b>	<b>30,496</b>	<b>30,185</b>	<b>30,948</b>	<b>-1592</b>
Static tipping load, articulated (with tire deflection)*	kg	11 257	11 118	11 434	11 166	11 026	11 341	-612
	lb	<b>24,812</b>	<b>24,505</b>	<b>25,202</b>	<b>24,611</b>	<b>24,303</b>	<b>24,997</b>	<b>-1349</b>
Static tipping load, articulated (no tire deflection)*	kg	12 008	11 868	12 195	11 919	11 778	12 104	-695
	lb	<b>26,466</b>	<b>26,157</b>	<b>26,879</b>	<b>26,270</b>	<b>25,959</b>	<b>26,678</b>	<b>-1532</b>
Breakout force	kN	187	186	203	180	179	194	-2
	lbf	<b>42,129</b>	<b>41,894</b>	<b>45,642</b>	<b>40,541</b>	<b>40,305</b>	<b>43,801</b>	<b>-4</b>
Operating weight*	kg	20 627	20 735	20 578	20 673	20 781	20 624	592
	lb	<b>45,461</b>	<b>45,699</b>	<b>45,353</b>	<b>45,563</b>	<b>45,801</b>	<b>45,455</b>	<b>1305</b>

\*Static tipping loads and operating weights shown are based on a machine configuration with Michelin 23.5R25 XHA2 L3 radial tires, full fluids, operator, cold start, roading fenders, Product Link, Manual Diff Lock/Open axles (front/rear), power train guard, secondary steering and sound suppression. (With Tire Deflection) Full compliance to ISO 14397-1 (2007) Sections 1 thru 6, which requires 2% verification between calculations and testing. (No Tire Deflection) Compliance to ISO 14397-1 (2007) Sections 1 thru 5.

**NOTE:** Machine and bucket availability varies by region. Consult your local dealer for availability.

Bucket Type Bucket Part Number	General Purpose — Hook On						High Lift Delta	
	354-4854	354-4854	354-4854	354-4856	354-4856	354-4856		
Edge Type	Bolt-on Cutting Edges	Teeth & Segments	Tips	Bolt-on Cutting Edges	Teeth & Segments	Tips		
Capacity — rated	m <sup>3</sup> yd <sup>3</sup>	3.40 4.45	3.40 4.45	3.20 4.19	3.60 4.71	3.60 4.71	3.40 4.45	— —
Capacity — 110%	m <sup>3</sup> yd <sup>3</sup>	3.74 4.89	3.74 4.89	3.52 4.60	3.96 5.18	3.96 5.18	3.74 4.89	— —
Width	mm ft/in	2927 9'7"	2994 9'9"	2994 9'9"	2927 9'7"	2994 9'9"	2994 9'9"	— —
Dump clearance at maximum lift and 45° discharge	mm ft/in	2996 9'9"	2877 9'5"	2877 9'5"	2970 9'8"	2850 9'4"	2850 9'4"	289 11"
Reach at maximum lift and 45° discharge	mm ft/in	1451 4'9"	1561 5'1"	1561 5'1"	1473 4'10"	1582 5'2"	1582 5'2"	101 3"
Reach at level lift arm and bucket level	mm ft/in	2919 9'6"	3080 10'1"	3080 10'1"	2954 9'8"	3115 10'2"	3115 10'2"	277 10"
Digging depth	mm in	88 3.5	88 3.5	58 2.3	88 3.5	88 3.5	58 2.3	6 0
Overall length	mm ft/in	8658 28'5"	8830 29'0"	8830 29'0"	8693 28'7"	8865 29'2"	8865 29'2"	372 1'2"
Overall height with bucket at maximum lift	mm ft/in	5847 19'3"	5847 19'3"	5847 19'3"	5881 19'4"	5881 19'4"	5881 19'4"	288 11"
Loader clearance circle with bucket at carry position	mm ft/in	13 932 45'9"	14 105 46'4"	14 105 46'4"	13 953 45'10"	14 127 46'5"	14 127 46'5"	308 1'0"
Static tipping load, straight (with tire deflection)*	kg lb	13 061 28,786	12 920 28,477	13 254 29,212	12 991 28,632	12 850 28,321	13 182 29,054	-631 -1391
Static tipping load, straight (no tire deflection)*	kg lb	13 793 30,399	13 651 30,087	13 996 30,848	13 724 30,248	13 582 29,935	13 926 30,693	-722 -1592
Static tipping load, articulated (with tire deflection)*	kg lb	11 124 24,518	10 984 24,208	11 298 24,901	11 058 24,373	10 917 24,062	11 231 24,753	-612 -1349
Static tipping load, articulated (no tire deflection)*	kg lb	11 877 26,178	11 736 25,866	12 061 26,584	11 813 26,036	11 671 25,722	11 996 26,439	-695 -1532
Breakout force	kN lbf	177 39,800	176 39,565	191 42,946	172 38,763	171 38,528	185 41,754	-2 -4
Operating weight*	kg lb	20 697 45,615	20 805 45,853	20 648 45,507	20 731 45,690	20 839 45,928	20 682 45,582	592 1305

\*Static tipping loads and operating weights shown are based on a machine configuration with Michelin 23.5R25 XHA2 L3 radial tires, full fluids, operator, cold start, roading fenders, Product Link, Manual Diff Lock/Open axles (front/rear), power train guard, secondary steering and sound suppression. (With Tire Deflection) Full compliance to ISO 14397-1 (2007) Sections 1 thru 6, which requires 2% verification between calculations and testing. (No Tire Deflection) Compliance to ISO 14397-1 (2007) Sections 1 thru 5.

**NOTE:** Machine and bucket availability varies by region. Consult your local dealer for availability.

Bucket Type Bucket Part Number	General Purpose — Hook On			Material Handling — Hook On			High Lift Delta	
	376-7801	376-7801	376-7801	354-4858	354-4858	354-4858		
Edge Type	Bolt-on Cutting Edges	Teeth & Segments	Tips	Bolt-on Cutting Edges	Teeth & Segments	Tips		
Capacity — rated	m <sup>3</sup> yd <sup>3</sup>	3.80 4.97	3.80 4.97	3.60 4.71	2.70 3.53	2.70 3.53	2.50 3.27	— —
Capacity — 110%	m <sup>3</sup> yd <sup>3</sup>	4.18 5.47	4.18 5.47	3.96 5.18	2.97 3.88	2.97 3.88	2.75 3.60	— —
Width	mm ft/in	2927 9'7"	2994 9'9"	2994 9'9"	2927 9'7"	2994 9'9"	2994 9'9"	— —
Dump clearance at maximum lift and 45° discharge	mm ft/in	2935 9'7"	2815 9'2"	2815 9'2"	3070 10'0"	2944 9'7"	2944 9'7"	289 11"
Reach at maximum lift and 45° discharge	mm ft/in	1502 4'11"	1611 5'3"	1611 5'3"	1248 4'1"	1350 4'5"	1350 4'5"	101 3"
Reach at level lift arm and bucket level	mm ft/in	3000 9'10"	3161 10'4"	3161 10'4"	2739 8'11"	2900 9'6"	2900 9'6"	277 10"
Digging depth	mm in	88 3.5	88 3.5	58 2.3	88 3.5	88 3.5	58 2.3	6 0
Overall length	mm ft/in	8739 28'9"	8911 29'3"	8911 29'3"	8478 27'10"	8650 28'5"	8650 28'5"	372 1'2"
Overall height with bucket at maximum lift	mm ft/in	5928 19'6"	5928 19'6"	5928 19'6"	5634 18'6"	5634 18'6"	5634 18'6"	288 11"
Loader clearance circle with bucket at carry position	mm ft/in	13 982 45'11"	14 157 46'6"	14 157 46'6"	13 822 45'5"	13 994 45'11"	13 994 45'11"	308 1'0"
Static tipping load, straight (with tire deflection)*	kg lb	12 899 28,429	12 757 28,117	13 088 28,847	13 293 29,299	13 158 29,000	13 484 29,719	-631 -1391
Static tipping load, straight (no tire deflection)*	kg lb	13 634 30,049	13 490 29,734	13 834 30,490	14 001 30,859	13 864 30,557	14 200 31,298	-722 -1592
Static tipping load, articulated (with tire deflection)*	kg lb	10 971 24,181	10 829 23,869	11 142 24,558	11 355 25,028	11 219 24,728	11 527 25,407	-612 -1349
Static tipping load, articulated (no tire deflection)*	kg lb	11 728 25,849	11 585 25,533	11 909 26,248	12 085 26,636	11 948 26,334	12 265 27,033	-695 -1532
Breakout force	kN lbf	166 37,471	165 37,236	179 40,274	204 46,011	203 45,776	223 50,188	-2 -4
Operating weight*	kg lb	20 776 45,789	20 884 46,027	20 727 45,681	20 516 45,217	20 624 45,455	20 467 45,109	592 1305

\*Static tipping loads and operating weights shown are based on a machine configuration with Michelin 23.5R25 XHA2 L3 radial tires, full fluids, operator, cold start, roading fenders, Product Link, Manual Diff Lock/Open axles (front/rear), power train guard, secondary steering and sound suppression. (With Tire Deflection) Full compliance to ISO 14397-1 (2007) Sections 1 thru 6, which requires 2% verification between calculations and testing. (No Tire Deflection) Compliance to ISO 14397-1 (2007) Sections 1 thru 5.

**NOTE:** Machine and bucket availability varies by region. Consult your local dealer for availability.

Bucket Type	Material Handling — Hook On							High Lift Delta
	Bucket Part Number	354-4860	354-4860	354-4860	354-4862	354-4862	354-4862	
Edge Type		Bolt-on Cutting Edges	Teeth & Segments	Tips	Bolt-on Cutting Edges	Teeth & Segments	Tips	
Capacity — rated	m <sup>3</sup>	2.90	2.90	2.70	3.10	3.10	2.90	—
	yd <sup>3</sup>	<b>3.79</b>	<b>3.79</b>	<b>3.53</b>	<b>4.05</b>	<b>4.05</b>	<b>3.79</b>	—
Capacity — 110%	m <sup>3</sup>	3.19	3.19	2.97	3.41	3.41	3.19	—
	yd <sup>3</sup>	<b>4.17</b>	<b>4.17</b>	<b>3.88</b>	<b>4.46</b>	<b>4.46</b>	<b>4.17</b>	—
Width	mm	2927	2994	2994	2927	2994	2994	—
	ft/in	<b>9'7"</b>	<b>9'9"</b>	<b>9'9"</b>	<b>9'7"</b>	<b>9'9"</b>	<b>9'9"</b>	—
Dump clearance at maximum lift and 45° discharge	mm	3027	2902	2902	2996	2870	2870	289
	ft/in	<b>9'11"</b>	<b>9'6"</b>	<b>9'6"</b>	<b>9'9"</b>	<b>9'5"</b>	<b>9'5"</b>	<b>11"</b>
Reach at maximum lift and 45° discharge	mm	1290	1393	1393	1322	1424	1424	101
	ft/in	<b>4'2"</b>	<b>4'6"</b>	<b>4'6"</b>	<b>4'4"</b>	<b>4'8"</b>	<b>4'8"</b>	<b>3"</b>
Reach at level lift arm and bucket level	mm	2799	2960	2960	2844	3005	3005	277
	ft/in	<b>9'2"</b>	<b>9'8"</b>	<b>9'8"</b>	<b>9'3"</b>	<b>9'10"</b>	<b>9'10"</b>	<b>10"</b>
Digging depth	mm	88	88	58	88	88	58	6
	in	<b>3.5</b>	<b>3.5</b>	<b>2.3</b>	<b>3.5</b>	<b>3.5</b>	<b>2.3</b>	<b>0</b>
Overall length	mm	8538	8710	8710	8583	8755	8755	372
	ft/in	<b>28'11"</b>	<b>28'7"</b>	<b>28'7"</b>	<b>28'2"</b>	<b>28'9"</b>	<b>28'9"</b>	<b>1'2"</b>
Overall height with bucket at maximum lift	mm	5697	5697	5697	5734	5734	5734	288
	ft/in	<b>18'9"</b>	<b>18'9"</b>	<b>18'9"</b>	<b>18'10"</b>	<b>18'10"</b>	<b>18'10"</b>	<b>11"</b>
Loader clearance circle with bucket at carry position	mm	13 858	14 030	14 030	13 886	14 058	14 058	308
	ft/in	<b>45'6"</b>	<b>46'1"</b>	<b>46'1"</b>	<b>45'7"</b>	<b>46'2"</b>	<b>46'2"</b>	<b>1'0"</b>
Static tipping load, straight (with tire deflection)*	kg	13 181	13 044	13 367	13 084	12 946	13 269	-631
	lb	<b>29,052</b>	<b>28,750</b>	<b>29,462</b>	<b>28,837</b>	<b>28,534</b>	<b>29,245</b>	<b>-1391</b>
Static tipping load, straight (no tire deflection)*	kg	13 891	13 753	14 086	13 795	13 656	13 989	-722
	lb	<b>30,617</b>	<b>30,313</b>	<b>31,046</b>	<b>30,405</b>	<b>30,100</b>	<b>30,833</b>	<b>-1592</b>
Static tipping load, articulated (with tire deflection)*	kg	11 250	11 113	11 418	11 158	11 020	11 325	-612
	lb	<b>24,795</b>	<b>24,493</b>	<b>25,165</b>	<b>24,593</b>	<b>24,289</b>	<b>24,961</b>	<b>-1349</b>
Static tipping load, articulated (no tire deflection)*	kg	11 982	11 844	12 158	11 891	11 753	12 067	-695
	lb	<b>26,408</b>	<b>26,104</b>	<b>26,797</b>	<b>26,209</b>	<b>25,903</b>	<b>26,596</b>	<b>-1532</b>
Breakout force	kN	194	193	211	187	186	203	-2
	lbf	<b>43,760</b>	<b>43,525</b>	<b>47,543</b>	<b>42,185</b>	<b>41,950</b>	<b>45,708</b>	<b>-4</b>
Operating weight*	kg	20 568	20 676	20 519	20 617	20 725	20 568	592
	lb	<b>45,331</b>	<b>45,569</b>	<b>45,223</b>	<b>45,439</b>	<b>45,677</b>	<b>45,331</b>	<b>1305</b>

\*Static tipping loads and operating weights shown are based on a machine configuration with Michelin 23.5R25 XHA2 L3 radial tires, full fluids, operator, cold start, roading fenders, Product Link, Manual Diff Lock/Open axles (front/rear), power train guard, secondary steering and sound suppression. (With Tire Deflection) Full compliance to ISO 14397-1 (2007) Sections 1 thru 6, which requires 2% verification between calculations and testing. (No Tire Deflection) Compliance to ISO 14397-1 (2007) Sections 1 thru 5.

**NOTE:** Machine and bucket availability varies by region. Consult your local dealer for availability.

Bucket Type	Material Handling — Hook On							High Lift Delta
	Bucket Part Number	354-4864	354-4864	354-4864	354-4866	354-4866	354-4866	
Edge Type		Bolt-on Cutting Edges	Teeth & Segments	Tips	Bolt-on Cutting Edges	Teeth & Segments	Tips	
Capacity — rated	m <sup>3</sup>	3.30	3.30	3.10	3.40	3.40	3.20	—
	yd <sup>3</sup>	4.32	4.32	4.05	4.45	4.45	4.19	—
Capacity — 110%	m <sup>3</sup>	3.63	3.63	3.41	3.74	3.74	3.52	—
	yd <sup>3</sup>	4.75	4.75	4.46	4.89	4.89	4.60	—
Width	mm	2927	2994	2994	2927	2994	2994	—
	ft/in	9'7"	9'9"	9'9"	9'7"	9'9"	9'9"	—
Dump clearance at maximum lift and 45° discharge	mm	2964	2838	2838	2936	2810	2810	289
	ft/in	9'8"	9'3"	9'3"	9'7"	9'2"	9'2"	11"
Reach at maximum lift and 45° discharge	mm	1354	1456	1456	1382	1485	1485	101
	ft/in	4'5"	4'9"	4'9"	4'6"	4'10"	4'10"	3"
Reach at level lift arm and bucket level	mm	2889	3050	3050	2929	3090	3090	277
	ft/in	9'5"	10'0"	10'0"	9'7"	10'1"	10'1"	10"
Digging depth	mm	88	88	58	88	88	58	6
	in	3.5	3.5	2.3	3.5	3.5	2.3	0
Overall length	mm	8628	8800	8800	8668	8840	8840	372
	ft/in	28'4"	28'11"	28'11"	28'6"	29'1"	29'1"	1'2"
Overall height with bucket at maximum lift	mm	5778	5778	5778	5817	5817	5817	288
	ft/in	19'0"	19'0"	19'0"	19'1"	19'1"	19'1"	11"
Loader clearance circle with bucket at carry position	mm	13 913	14 086	14 086	13 938	14 112	14 112	308
	ft/in	45'8"	46'3"	46'3"	45'9"	46'4"	46'4"	1'0"
Static tipping load, straight (with tire deflection)*	kg	12 992	12 853	13 179	12 916	12 777	13 099	-631
	lb	28,634	28,329	29,048	28,467	28,160	28,871	-1391
Static tipping load, straight (no tire deflection)*	kg	13 704	13 565	13 902	13 630	13 490	13 823	-722
	lb	30,205	29,897	30,640	30,042	29,732	30,466	-1592
Static tipping load, articulated (with tire deflection)*	kg	11 071	10 933	11 241	11 000	10 860	11 165	-612
	lb	24,402	24,097	24,775	24,244	23,937	24,609	-1349
Static tipping load, articulated (no tire deflection)*	kg	11 806	11 667	11 985	11 736	11 596	11 911	-695
	lb	26,021	25,714	26,415	25,867	25,558	26,251	-1532
Breakout force	kN	181	180	195	175	174	189	-2
	lbf	40,717	40,482	44,006	39,488	39,253	42,588	-4
Operating weight*	kg	20 661	20 769	20 612	20 699	20 807	20 650	592
	lb	45,536	45,774	45,428	45,620	45,858	45,512	1305

\*Static tipping loads and operating weights shown are based on a machine configuration with Michelin 23.5R25 XHA2 L3 radial tires, full fluids, operator, cold start, roading fenders, Product Link, Manual Diff Lock/Open axles (front/rear), power train guard, secondary steering and sound suppression. (With Tire Deflection) Full compliance to ISO 14397-1 (2007) Sections 1 thru 6, which requires 2% verification between calculations and testing. (No Tire Deflection) Compliance to ISO 14397-1 (2007) Sections 1 thru 5.

**NOTE:** Machine and bucket availability varies by region. Consult your local dealer for availability.



Bucket Type	Material Handling — Hook On						High Lift Delta	
	367-5735	367-5735	367-5735	354-4868	354-4868	354-4868		
Bucket Part Number	Bolt-on Cutting Edges	Teeth & Segments	Tips	Bolt-on Cutting Edges	Teeth & Segments	Tips		
Edge Type								
Capacity — rated	m <sup>3</sup>	3.60	3.60	3.40	3.80	3.80	3.60	—
	yd <sup>3</sup>	<b>4.71</b>	<b>4.71</b>	<b>4.45</b>	<b>4.97</b>	<b>4.97</b>	<b>4.71</b>	—
Capacity — 110%	m <sup>3</sup>	3.96	3.96	3.74	4.18	4.18	3.96	—
	yd <sup>3</sup>	<b>5.18</b>	<b>5.18</b>	<b>4.89</b>	<b>5.47</b>	<b>5.47</b>	<b>5.18</b>	—
Width	mm	2927	2994	2994	2927	2994	2994	—
	ft/in	<b>9'7"</b>	<b>9'9"</b>	<b>9'9"</b>	<b>9'7"</b>	<b>9'9"</b>	<b>9'9"</b>	—
Dump clearance at maximum lift and 45° discharge	mm	2904	2778	2778	2868	2742	2742	289
	ft/in	<b>9'6"</b>	<b>9'1"</b>	<b>9'1"</b>	<b>9'4"</b>	<b>8'11"</b>	<b>8'11"</b>	<b>11"</b>
Reach at maximum lift and 45° discharge	mm	1414	1516	1516	1450	1552	1552	101
	ft/in	<b>4'7"</b>	<b>4'11"</b>	<b>4'11"</b>	<b>4'9"</b>	<b>5'1"</b>	<b>5'1"</b>	<b>3"</b>
Reach at level lift arm and bucket level	mm	2974	3135	3135	3025	3186	3186	277
	ft/in	<b>9'9"</b>	<b>10'3"</b>	<b>10'3"</b>	<b>9'11"</b>	<b>10'5"</b>	<b>10'5"</b>	<b>10"</b>
Digging depth	mm	88	88	58	88	88	58	6
	in	<b>3.5</b>	<b>3.5</b>	<b>2.3</b>	<b>3.5</b>	<b>3.5</b>	<b>2.3</b>	<b>0</b>
Overall length	mm	8713	8885	8885	8764	8936	8936	372
	ft/in	<b>28'8"</b>	<b>29'2"</b>	<b>29'2"</b>	<b>28'10"</b>	<b>29'4"</b>	<b>29'4"</b>	<b>1'2"</b>
Overall height with bucket at maximum lift	mm	5860	5860	5860	5913	5913	5913	288
	ft/in	<b>19'3"</b>	<b>19'3"</b>	<b>19'3"</b>	<b>19'5"</b>	<b>19'5"</b>	<b>19'5"</b>	<b>11"</b>
Loader clearance circle with bucket at carry position	mm	13 966	14 140	14 140	13 998	14 173	14 173	308
	ft/in	<b>45'10"</b>	<b>46'5"</b>	<b>46'5"</b>	<b>46'0"</b>	<b>46'6"</b>	<b>46'6"</b>	<b>1'0"</b>
Static tipping load, straight (with tire deflection)*	kg	12 828	12 688	13 011	12 723	12 582	12 905	-631
	lb	<b>28,273</b>	<b>27,965</b>	<b>28,676</b>	<b>28,042</b>	<b>27,731</b>	<b>28,443</b>	<b>-1391</b>
Static tipping load, straight (no tire deflection)*	kg	13 544	13 402	13 736	13 440	13 298	13 632	-722
	lb	<b>29,851</b>	<b>29,540</b>	<b>30,274</b>	<b>29,623</b>	<b>29,310</b>	<b>30,044</b>	<b>-1592</b>
Static tipping load, articulated (with tire deflection)*	kg	10 917	10 777	11 082	10 818	10 677	10 982	-612
	lb	<b>24,062</b>	<b>23,754</b>	<b>24,426</b>	<b>23,843</b>	<b>23,533</b>	<b>24,206</b>	<b>-1349</b>
Static tipping load, articulated (no tire deflection)*	kg	11 655	11 514	11 829	11 557	11 415	11 731	-695
	lb	<b>25,688</b>	<b>25,377</b>	<b>26,072</b>	<b>25,473</b>	<b>25,160</b>	<b>25,855</b>	<b>-1532</b>
Breakout force	kN	169	168	182	163	162	175	-2
	lbf	<b>38,188</b>	<b>37,953</b>	<b>41,095</b>	<b>36,790</b>	<b>36,555</b>	<b>39,498</b>	<b>-4</b>
Operating weight*	kg	20 739	20 847	20 690	20 793	20 901	20 744	592
	lb	<b>45,708</b>	<b>45,946</b>	<b>45,600</b>	<b>45,827</b>	<b>46,065</b>	<b>45,719</b>	<b>1305</b>

\*Static tipping loads and operating weights shown are based on a machine configuration with Michelin 23.5R25 XHA2 L3 radial tires, full fluids, operator, cold start, roading fenders, Product Link, Manual Diff Lock/Open axles (front/rear), power train guard, secondary steering and sound suppression. (With Tire Deflection) Full compliance to ISO 14397-1 (2007) Sections 1 thru 6, which requires 2% verification between calculations and testing. (No Tire Deflection) Compliance to ISO 14397-1 (2007) Sections 1 thru 5.

**NOTE:** Machine and bucket availability varies by region. Consult your local dealer for availability.

Bucket Type Bucket Part Number		General Purpose — Pin On		
		395-2119	416-6342	416-6343
Edge Type		Bolt-on Cutting Edges	Bolt-on Cutting Edges	Bolt-on Cutting Edges
Capacity — rated	m <sup>3</sup>	3.80	4.00	4.20
	yd <sup>3</sup>	<b>4.97</b>	<b>5.23</b>	<b>5.49</b>
Capacity — 110%	m <sup>3</sup>	4.18	4.40	4.62
	yd <sup>3</sup>	<b>5.47</b>	<b>5.75</b>	<b>6.04</b>
Width	mm	2994	2994	2994
	ft/in	<b>9'9"</b>	<b>9'9"</b>	<b>9'9"</b>
Dump clearance at maximum lift and 45° discharge	mm	2992	2962	2929
	ft/in	<b>9'9"</b>	<b>9'8"</b>	<b>9'7"</b>
Reach at maximum lift and 45° discharge	mm	1440	1466	1496
	ft/in	<b>4'8"</b>	<b>4'9"</b>	<b>4'10"</b>
Reach at level lift arm and bucket level	mm	2916	2956	3001
	ft/in	<b>9'6"</b>	<b>9'8"</b>	<b>9'10"</b>
Digging depth	mm	88	88	88
	in	<b>3.5</b>	<b>3.5</b>	<b>3.5</b>
Overall length	mm	8694	8734	8779
	ft/in	<b>28'7"</b>	<b>28'8"</b>	<b>28'10"</b>
Overall height with bucket at maximum lift	mm	5897	5937	5984
	ft/in	<b>19'5"</b>	<b>19'6"</b>	<b>19'8"</b>
Loader clearance circle with bucket at carry position	mm	13 997	14 021	14 049
	ft/in	<b>46'0"</b>	<b>46'0"</b>	<b>46'2"</b>
Static tipping load, straight (with tire deflection)*	kg	14 514	14 412	14 314
	lb	<b>31,989</b>	<b>31,764</b>	<b>31,548</b>
Static tipping load, straight (no tire deflection)*	kg	15 338	15 237	15 141
	lb	<b>33,805</b>	<b>33,584</b>	<b>33,372</b>
Static tipping load, articulated (with tire deflection)*	kg	12 359	12 262	12 170
	lb	<b>27,239</b>	<b>27,027</b>	<b>26,823</b>
Static tipping load, articulated (no tire deflection)*	kg	13 211	13 116	13 026
	lb	<b>29,117</b>	<b>28,908</b>	<b>28,709</b>
Breakout force	kN	176	171	165
	lbf	<b>39,704</b>	<b>38,496</b>	<b>37,233</b>
Operating weight*	kg	20 984	21 038	21 084
	lb	<b>46,249</b>	<b>46,368</b>	<b>46,469</b>

\*Static tipping loads and operating weights shown are based on a machine configuration with Michelin 23.5R25 XHA2 L3 radial tires, full fluids, operator, cold start, roading fenders, Product Link, Manual Diff Lock/Open axles (front/rear), power train guard, secondary steering and sound suppression. (With Tire Deflection) Full compliance to ISO 14397-1 (2007) Sections 1 thru 6, which requires 2% verification between calculations and testing. (No Tire Deflection) Compliance to ISO 14397-1 (2007) Sections 1 thru 5.

**NOTE:** Machine and bucket availability varies by region. Consult your local dealer for availability.

Bucket Type	General Purpose — Pin On							High Lift Delta
	Bucket Part Number	394-8476	394-8476	394-8476	395-3949	395-3949	395-3949	
Edge Type		Bolt-on Cutting Edges	Teeth & Segments	Tips	Bolt-on Cutting Edges	Teeth & Segments	Tips	
Capacity — rated	m <sup>3</sup>	3.40	3.40	3.20	3.60	3.60	3.40	—
	yd <sup>3</sup>	4.45	4.45	4.19	4.71	4.71	4.45	—
Capacity — 110%	m <sup>3</sup>	3.74	3.74	3.52	3.96	3.96	3.74	—
	yd <sup>3</sup>	4.89	4.89	4.60	5.18	5.18	4.89	—
Width	mm	2927	2994	2994	2927	2994	2994	—
	ft/in	9'7"	9'9"	9'9"	9'7"	9'9"	9'9"	—
Dump clearance at maximum lift and 45° discharge	mm	2981	2862	2862	2935	2816	2816	305
	ft/in	9'9"	9'4"	9'4"	9'7"	9'2"	9'2"	1'0"
Reach at maximum lift and 45° discharge	mm	1321	1431	1431	1357	1467	1467	117
	ft/in	4'4"	4'8"	4'8"	4'5"	4'9"	4'9"	4"
Reach at level lift arm and bucket level	mm	2812	2973	2973	2872	3033	3033	305
	ft/in	9'2"	9'9"	9'9"	9'5"	9'11"	9'11"	1'0"
Digging depth	mm	90	90	60	90	90	60	21
	in	3.5	3.5	2.3	3.5	3.5	2.3	0.8
Overall length	mm	8431	8604	8604	8491	8664	8664	485
	ft/in	27'8"	28'3"	28'3"	27'11"	28'6"	28'6"	1'8"
Overall height with bucket at maximum lift	mm	5719	5719	5719	5777	5777	5777	306
	ft/in	18'10"	18'10"	18'10"	19'0"	19'0"	19'0"	1'1"
Loader clearance circle with bucket at carry position	mm	6764	6848	6848	6781	6866	6866	-2
	ft/in	22'3"	22'6"	22'6"	22'3"	22'7"	22'7"	-1"
Static tipping load, straight (with tire deflection)*	kg	13 550	13 410	13 669	13 430	13 289	13 547	-64
	lb	29,865	29,557	30,128	29,600	29,290	29,858	-141
Static tipping load, straight (no tire deflection)*	kg	14 301	14 160	14 423	14 183	14 041	14 303	-83
	lb	31,519	31,208	31,788	31,261	30,947	31,524	-185
Static tipping load, articulated (with tire deflection)*	kg	11 640	11 500	11 742	11 527	11 386	11 626	-150
	lb	25,655	25,347	25,880	25,406	25,096	25,625	-332
Static tipping load, articulated (no tire deflection)*	kg	12 397	12 255	12 501	12 286	12 144	12 387	-156
	lb	27,323	27,012	27,552	27,079	26,766	27,302	-345
Breakout force	kN	142	141	154	136	135	146	-9
	lbf	32,071	31,814	34,698	30,589	30,333	32,990	-2054
Operating weight*	kg	19 153	19 261	19 104	19 211	19 319	19 162	1071
	lb	42,212	42,450	42,104	42,340	42,578	42,232	2361

\*Static tipping loads and operating weights shown are based on a machine configuration with Michelin 23.5R25 XHA2 L3 radial tires, full fluids, operator, cold start, roading fenders, Product Link, Open/Open axles (front/rear), power train guard, secondary steering and sound suppression.

(With Tire Deflection) Full compliance to ISO 14397-1 (2007) Sections 1 thru 6, which requires 2% verification between calculations and testing.

(No Tire Deflection) Compliance to ISO 14397-1 (2007) Sections 1 thru 5.

**NOTE:** Machine and bucket availability varies by region. Consult your local dealer for availability.

Bucket Type	General Purpose — Hook On			Material Handling — Pin On			High Lift Delta	
	382-9835	382-9835	382-9835	396-1542	396-1542	396-1542		
Bucket Part Number	Bolt-on Cutting Edges	Teeth & Segments	Tips	Bolt-on Cutting Edges	Teeth & Segments	Tips		
Edge Type								
Capacity — rated	m <sup>3</sup> yd <sup>3</sup>	3.40 4.45	3.40 4.45	3.20 4.19	3.60 4.71	3.60 4.71	3.40 4.45	— —
Capacity — 110%	m <sup>3</sup> yd <sup>3</sup>	3.74 4.89	3.74 4.89	3.52 4.60	3.96 5.18	3.96 5.18	3.74 4.89	— —
Width	mm ft/in	2927 9'7"	2994 9'9"	2994 9'9"	2927 9'7"	2994 9'9"	2994 9'9"	— —
Dump clearance at maximum lift and 45° discharge	mm ft/in	2939 9'7"	2820 9'3"	2820 9'3"	2876 9'5"	2750 9'0"	2750 9'0"	305 1'0"
Reach at maximum lift and 45° discharge	mm ft/in	1357 4'5"	1467 4'9"	1467 4'9"	1276 4'2"	1378 4'6"	1378 4'6"	117 4"
Reach at level lift arm and bucket level	mm ft/in	2867 9'4"	3028 9'11"	3028 9'11"	2872 9'5"	3033 9'11"	3033 9'11"	305 1'0"
Digging depth	mm in	98 3.8	98 3.8	68 2.6	98 3.8	98 3.8	68 2.6	21 0.8
Overall length	mm ft/in	8492 27'11"	8665 28'6"	8665 28'6"	8497 27'11"	8670 28'6"	8670 28'6"	485 1'8"
Overall height with bucket at maximum lift	mm ft/in	5738 18'10"	5738 18'10"	5738 18'10"	5779 19'0"	5779 19'0"	5779 19'0"	306 1'1"
Loader clearance circle with bucket at carry position	mm ft/in	6780 22'3"	6866 22'7"	6866 22'7"	6785 22'4"	6869 22'7"	6869 22'7"	-2 -1"
Static tipping load, straight (with tire deflection)*	kg lb	12 933 28,505	12 794 28,198	13 116 28,908	13 315 29,347	13 175 29,039	13 427 29,594	-64 -141
Static tipping load, straight (no tire deflection)*	kg lb	13 670 30,130	13 529 29,820	13 862 30,552	14 053 30,974	13 912 30,663	14 168 31,226	-83 -185
Static tipping load, articulated (with tire deflection)*	kg lb	11 051 24,357	10 911 24,050	11 217 24,722	11 429 25,189	11 289 24,881	11 524 25,400	-150 -332
Static tipping load, articulated (no tire deflection)*	kg lb	11 794 25,995	11 654 25,685	11 968 26,379	12 173 26,831	12 032 26,520	12 271 27,045	-156 -345
Breakout force	kN lbf	136 30,658	135 30,399	147 33,070	136 30,569	134 30,311	146 32,966	-9 -2054
Operating weight*	kg lb	19 632 43,268	19 740 43,506	19 583 43,160	19 204 42,324	19 312 42,563	19 155 42,216	1071 2361

\*Static tipping loads and operating weights shown are based on a machine configuration with Michelin 23.5R25 XHA2 L3 radial tires, full fluids, operator, cold start, roading fenders, Product Link, Open/Open axles (front/rear), power train guard, secondary steering and sound suppression.  
(With Tire Deflection) Full compliance to ISO 14397-1 (2007) Sections 1 thru 6, which requires 2% verification between calculations and testing.  
(No Tire Deflection) Compliance to ISO 14397-1 (2007) Sections 1 thru 5.

**NOTE:** Machine and bucket availability varies by region. Consult your local dealer for availability.

Bucket Type		Material Handling — Pin On			High Lift Delta
		396-1545	396-1545	396-1545	
Bucket Part Number		Bolt-on Cutting Edges	Teeth & Segments	Tips	
Edge Type					
Capacity — rated	m <sup>3</sup>	3.80	3.80	3.60	—
	yd <sup>3</sup>	<b>4.97</b>	<b>4.97</b>	<b>4.71</b>	—
Capacity — 110%	m <sup>3</sup>	4.18	4.18	3.96	—
	yd <sup>3</sup>	<b>5.47</b>	<b>5.47</b>	<b>5.18</b>	—
Width	mm	2927	2994	2994	—
	ft/in	<b>9'7"</b>	<b>9'9"</b>	<b>9'9"</b>	—
Dump clearance at maximum lift and 45° discharge	mm	2833	2707	2707	305
	ft/in	<b>9'3"</b>	<b>8'10"</b>	<b>8'10"</b>	<b>1'0"</b>
Reach at maximum lift and 45° discharge	mm	1319	1421	1421	117
	ft/in	<b>4'3"</b>	<b>4'7"</b>	<b>4'7"</b>	<b>4"</b>
Reach at level lift arm and bucket level	mm	2933	3094	3094	305
	ft/in	<b>9'7"</b>	<b>10'1"</b>	<b>10'1"</b>	<b>1'0"</b>
Digging depth	mm	98	98	68	21
	in	<b>3.8</b>	<b>3.8</b>	<b>2.6</b>	<b>0.8</b>
Overall length	mm	8558	8731	8731	485
	ft/in	<b>28'1"</b>	<b>28'8"</b>	<b>28'8"</b>	<b>1'8"</b>
Overall height with bucket at maximum lift	mm	5828	5828	5828	306
	ft/in	<b>19'2"</b>	<b>19'2"</b>	<b>19'2"</b>	<b>1'1"</b>
Loader clearance circle with bucket at carry position	mm	6803	6888	6888	-2
	ft/in	<b>22'4"</b>	<b>22'8"</b>	<b>22'8"</b>	<b>-1"</b>
Static tipping load, straight (with tire deflection)*	kg	13 202	13 062	13 306	-64
	lb	<b>29,099</b>	<b>28,789</b>	<b>29,326</b>	<b>-141</b>
Static tipping load, straight (no tire deflection)*	kg	13 944	13 802	14 049	-83
	lb	<b>30,733</b>	<b>30,419</b>	<b>30,964</b>	<b>-185</b>
Static tipping load, articulated (with tire deflection)*	kg	11 322	11 181	11 409	-150
	lb	<b>24,955</b>	<b>24,644</b>	<b>25,147</b>	<b>-332</b>
Static tipping load, articulated (no tire deflection)*	kg	12 070	11 928	12 158	-156
	lb	<b>26,603</b>	<b>26,290</b>	<b>26,798</b>	<b>-345</b>
Breakout force	kN	129	128	139	-9
	lbf	<b>29,185</b>	<b>28,927</b>	<b>31,380</b>	<b>-2054</b>
Operating weight*	kg	19 260	19 368	19 211	1071
	lb	<b>42,448</b>	<b>42,686</b>	<b>42,340</b>	<b>2361</b>

\*Static tipping loads and operating weights shown are based on a machine configuration with Michelin 23.5R25 XHA2 L3 radial tires, full fluids, operator, cold start, roading fenders, Product Link, Open/Open axles (front/rear), power train guard, secondary steering and sound suppression. (With Tire Deflection) Full compliance to ISO 14397-1 (2007) Sections 1 thru 6, which requires 2% verification between calculations and testing. (No Tire Deflection) Compliance to ISO 14397-1 (2007) Sections 1 thru 5.

**NOTE:** Machine and bucket availability varies by region. Consult your local dealer for availability.

Linkage Bucket Type	Standard Linkage			Standard Linkage			High Lift Linkage Change**	
	General Purpose – Pin On							
Edge Type	Bolt-on Cutting Edges	Teeth & Segments	Tips	Bolt-on Cutting Edges	Teeth & Segments	Tips		
Capacity — rated	m <sup>3</sup> yd <sup>3</sup>	3.80 5.00	3.80 5.00	3.60 4.75	4.00 5.25	4.00 5.25	3.80 5.00	— —
Capacity — rated at 110% fill factor	m <sup>3</sup> yd <sup>3</sup>	4.18 5.47	4.18 5.47	3.96 5.18	4.40 5.75	4.40 5.75	4.18 5.47	— —
Width	mm ft/in	3220 10'6"	3271 10'8"	3271 10'8"	3220 10'6"	3271 10'8"	3271 10'8"	— —
Dump clearance at maximum lift and 45° discharge	mm ft/in	3067 10'0"	2915 9'6"	2915 9'6"	3058 10'0"	2905 9'6"	2905 9'6"	558 1'10"
Reach at maximum lift and 45° discharge	mm ft/in	1292 4'2"	1432 4'8"	1432 4'8"	1299 4'3"	1438 4'8"	1438 4'8"	-24 -0.9"
Reach at level lift arm and bucket level	mm ft/in	2704 8'10"	2908 9'6"	2908 9'6"	2715 8'10"	2920 9'6"	2920 9'6"	405 1'4"
Digging depth	mm in	124 4.9	124 4.9	94 3.7	124 4.9	124 4.9	94 3.7	-25 -1
Shipping length (With Bucket)	mm ft/in	8651 28'5"	8876 29'2"	8876 29'2"	8663 28'6"	8888 29'2"	8888 29'2"	820 2'8"
Overall height with bucket at maximum lift	mm ft/in	5788 19'0"	5788 19'0"	5788 19'0"	5902 19'5"	5902 19'5"	5902 19'5"	558 1'10"
Loader clearance circle with bucket at carry position	mm ft/in	14 973 49'2"	15 142 49'9"	15 142 49'9"	14 979 49'2"	15 148 49'9"	15 148 49'9"	479 1'7"
Static tipping load, straight (with tire deflection)*	kg lb	16 874 37,192	16 693 36,791	16 891 37,229	16 856 37,152	16 674 36,750	16 908 37,266	22 48
Static tipping load, straight (no tire deflection)*	kg lb	18 045 39,772	17 860 39,364	18 048 39,777	18 037 39,754	17 851 39,344	18 088 39,867	-75 -165
Static tipping load, articulated (with tire deflection)*	kg lb	14 876 32,788	14 693 32,384	14 883 32,804	14 855 32,741	14 671 32,335	14 890 32,818	-163 -359
Static tipping load, articulated (no tire deflection)*	kg lb	16 029 35,329	15 844 34,921	16 023 35,315	16 017 35,303	15 831 34,893	16 052 35,379	-225 -496
Breakout force	kN lbf	187 42,151	185 41,781	199 44,901	185 41,695	183 41,326	197 44,390	-17 -37
Operating weight*	kg lb	23 112 50,938	23 250 51,242	23 087 50,883	23 164 51,053	23 302 51,357	23 139 50,997	1612 3553

\*Static tipping loads and operating weights shown are based on a machine configuration with Michelin 26.5R25 XHA2 L3 radial tires, full fluids, operator, standard counterweight, cold start, roading fenders, Product Link, Manual Diff Lock/Open axles (front/rear), power train guard, secondary steering and sound suppression.

\*\*Maximum values.

(With Tire Deflection) Full compliance to ISO 14397-1 (2007) Sections 1 thru 6, which requires 2% verification between calculations and testing.  
(No Tire Deflection) Compliance to ISO 14397-1 (2007) Sections 1 thru 5.

**NOTE:** Machine and bucket availability varies by region. Consult your local dealer for availability.

Linkage Bucket Type	Standard Linkage			Standard Linkage			High Lift Linkage Change**	
	General Purpose – Pin On			General Purpose – Fusion QC				
Edge Type	Bolt-on Cutting Edges	Teeth & Segments	Tips	Bolt-on Cutting Edges	Teeth & Segments	Tips		
Capacity – rated	m <sup>3</sup>	4.20	4.20	4.00	3.80	3.80	3.60	–
	yd <sup>3</sup>	<b>5.50</b>	<b>5.50</b>	<b>5.25</b>	<b>5.00</b>	<b>5.00</b>	<b>4.75</b>	–
Capacity – rated at 110% fill factor	m <sup>3</sup>	4.62	4.62	4.40	4.18	4.18	3.96	–
	yd <sup>3</sup>	<b>6.04</b>	<b>6.04</b>	<b>5.75</b>	<b>5.47</b>	<b>5.47</b>	<b>5.18</b>	–
Width	mm	3220	3271	3271	3220	3271	3271	–
	ft/in	<b>10'6"</b>	<b>10'8"</b>	<b>10'8"</b>	<b>10'6"</b>	<b>10'8"</b>	<b>10'8"</b>	–
Dump clearance at maximum lift and 45° discharge	mm	2991	2837	2837	3038	2886	2886	558
	ft/in	<b>9'9"</b>	<b>9'3"</b>	<b>9'3"</b>	<b>9'11"</b>	<b>9'5"</b>	<b>9'5"</b>	<b>1'10"</b>
Reach at maximum lift and 45° discharge	mm	1353	1490	1490	1327	1466	1466	–25
	ft/in	<b>4'5"</b>	<b>4'10"</b>	<b>4'10"</b>	<b>4'4"</b>	<b>4'9"</b>	<b>4'9"</b>	<b>–1"</b>
Reach at level lift arm and bucket level	mm	2803	3008	3008	2748	2953	2953	404
	ft/in	<b>9'2"</b>	<b>9'10"</b>	<b>9'10"</b>	<b>9'0"</b>	<b>9'8"</b>	<b>9'8"</b>	<b>1'4"</b>
Digging depth	mm	124	124	94	124	124	94	–25
	in	<b>4.9</b>	<b>4.9</b>	<b>3.7</b>	<b>4.9</b>	<b>4.9</b>	<b>3.7</b>	<b>–1</b>
Shipping length (With Bucket)	mm	8750	8975	8975	8696	8921	8921	820
	ft/in	<b>28'9"</b>	<b>29'6"</b>	<b>29'6"</b>	<b>28'7"</b>	<b>29'4"</b>	<b>29'4"</b>	<b>2'8"</b>
Overall height with bucket at maximum lift	mm	5902	5902	5902	5803	5803	5803	558
	ft/in	<b>19'5"</b>	<b>19'5"</b>	<b>19'5"</b>	<b>19'1"</b>	<b>19'1"</b>	<b>19'1"</b>	<b>1'10"</b>
Loader clearance circle with bucket at carry position	mm	15 022	15 193	15 193	14 988	15 160	15 160	487
	ft/in	<b>49'4"</b>	<b>49'11"</b>	<b>49'11"</b>	<b>49'3"</b>	<b>49'9"</b>	<b>49'9"</b>	<b>1'7"</b>
Static tipping load, straight (with tire deflection)*	kg	16 656	16 473	16 714	16 299	16 118	16 461	51
	lb	<b>36,711</b>	<b>36,307</b>	<b>36,839</b>	<b>35,923</b>	<b>35,524</b>	<b>36,281</b>	<b>112</b>
Static tipping load, straight (no tire deflection)*	kg	17 828	17 641	17 886	17 442	17 258	17 617	–44
	lb	<b>39,293</b>	<b>38,881</b>	<b>39,421</b>	<b>38,444</b>	<b>38,038</b>	<b>38,828</b>	<b>–97</b>
Static tipping load, articulated (with tire deflection)*	kg	14 668	14 483	14 709	14 323	14 140	14 470	–137
	lb	<b>32,329</b>	<b>31,921</b>	<b>32,420</b>	<b>31,568</b>	<b>31,166</b>	<b>31,892</b>	<b>–302</b>
Static tipping load, articulated (no tire deflection)*	kg	15 822	15 636	15 864	15 453	15 269	15 611	–196
	lb	<b>34,873</b>	<b>34,461</b>	<b>34,964</b>	<b>34,059</b>	<b>33,653</b>	<b>34,408</b>	<b>–432</b>
Breakout force	kN	173	171	184	180	179	192	–16
	lbf	<b>38,984</b>	<b>38,618</b>	<b>41,343</b>	<b>40,632</b>	<b>40,264</b>	<b>43,192</b>	<b>–35</b>
Operating weight*	kg	23 220	23 358	23 195	23 529	23 667	23 504	1612
	lb	<b>51,176</b>	<b>51,480</b>	<b>51,121</b>	<b>51,857</b>	<b>52,161</b>	<b>51,802</b>	<b>3553</b>

\*Static tipping loads and operating weights shown are based on a machine configuration with Michelin 26.5R25 XHA2 L3 radial tires, full fluids, operator, standard counterweight, cold start, roading fenders, Product Link, Manual Diff Lock/Open axles (front/rear), power train guard, secondary steering and sound suppression.

\*\*Maximum values.

(With Tire Deflection) Full compliance to ISO 14397-1 (2007) Sections 1 thru 6, which requires 2% verification between calculations and testing.  
(No Tire Deflection) Compliance to ISO 14397-1 (2007) Sections 1 thru 5.

**NOTE:** Machine and bucket availability varies by region. Consult your local dealer for availability.

Linkage Bucket Type	Standard Linkage			Standard Linkage			High Lift Linkage Change**	
	General Purpose – Fusion QC			Material Handling – Pin On				
Edge Type	Bolt-on Cutting Edges	Teeth & Segments	Tips	Bolt-on Cutting Edges	Teeth & Segments	Tips		
Capacity – rated	m <sup>3</sup> yd <sup>3</sup>	4.20 5.50	4.20 5.50	4.00 5.25	4.20 5.50	4.20 5.50	4.04 5.30	– –
Capacity – rated at 110% fill factor	m <sup>3</sup> yd <sup>3</sup>	4.62 6.04	4.62 6.04	4.40 5.75	4.62 6.04	4.62 6.04	4.44 5.81	– –
Width	mm ft/in	3220 10'6"	3271 10'8"	3271 10'8"	3220 10'6"	3271 10'8"	3271 10'8"	– –
Dump clearance at maximum lift and 45° discharge	mm ft/in	2960 9'8"	2806 9'2"	2806 9'2"	2949 9'8"	2787 9'1"	2787 9'1"	559 1'10"
Reach at maximum lift and 45° discharge	mm ft/in	1398 4'7"	1536 5'0"	1536 5'0"	1245 4'1"	1372 4'6"	1372 4'6"	–24 –0.9"
Reach at level lift arm and bucket level	mm ft/in	2858 9'4"	3062 10'0"	3062 10'0"	2774 9'1"	2978 9'9"	2978 9'9"	405 1'4"
Digging depth	mm in	116 4.5	116 4.5	86 3.4	124 4.9	124 4.9	94 3.7	–25 –1
Shipping length (With Bucket)	mm ft/in	8798 28'11"	9024 29'8"	9024 29'8"	8721 28'8"	8946 29'5"	8946 29'5"	822 2'8"
Overall height with bucket at maximum lift	mm ft/in	5960 19'7"	5960 19'7"	5960 19'7"	5901 19'5"	5901 19'5"	5901 19'5"	558 1'10"
Loader clearance circle with bucket at carry position	mm ft/in	15 038 49'5"	15 212 49'11"	15 212 49'11"	15 008 49'3"	15 178 49'10"	15 178 49'10"	493 1'7"
Static tipping load, straight (with tire deflection)*	kg lb	16 031 35,334	15 850 34,933	16 186 35,675	16 580 36,544	16 398 36,143	16 729 36,871	95 209
Static tipping load, straight (no tire deflection)*	kg lb	17 173 37,850	16 988 37,442	17 339 38,216	17 731 39,080	17 546 38,672	17 890 39,430	34 75
Static tipping load, articulated (with tire deflection)*	kg lb	14 075 31,022	13 892 30,618	14 216 31,332	14 605 32,190	14 421 31,786	14 738 32,483	–106 –234
Static tipping load, articulated (no tire deflection)*	kg lb	15 204 33,510	15 019 33,102	15 355 33,843	15 740 34,691	15 555 34,283	15 883 35,006	–158 –348
Breakout force	kN lbf	166 37,382	164 37,023	176 39,561	177 39,834	175 39,468	188 42,297	–15 –33
Operating weight*	kg lb	23 592 51,997	23 730 52,301	23 567 51,941	23 217 51,170	23 355 51,474	23 192 51,114	1612 3553

\*Static tipping loads and operating weights shown are based on a machine configuration with Michelin 26.5R25 XHA2 L3 radial tires, full fluids, operator, standard counterweight, cold start, roading fenders, Product Link, Manual Diff Lock/Open axles (front/rear), power train guard, secondary steering and sound suppression.

\*\*Maximum values.

(With Tire Deflection) Full compliance to ISO 14397-1 (2007) Sections 1 thru 6, which requires 2% verification between calculations and testing. (No Tire Deflection) Compliance to ISO 14397-1 (2007) Sections 1 thru 5.

**NOTE:** Machine and bucket availability varies by region. Consult your local dealer for availability.



# Wheel Loaders Integrated Toolcarriers

## Performance Data ● 966L/966M Aggregate Handler

Package	Aggregate Handler			Aggregate Handler		Aggregate Handler	
Bucket Type	General Purpose – Pin On			General Purpose – Fusion QC		Material Handling – Pin On	
Edge Type	Bolt-on Cutting Edges	Bolt-on Cutting Edges	Bolt-on Cutting Edges	Bolt-on Cutting Edges	Bolt-on Cutting Edges	Bolt-on Cutting Edges	
Capacity – rated	m <sup>3</sup> yd <sup>3</sup>	3.80 <b>5.00</b>	4.00 <b>5.25</b>	4.20 <b>5.50</b>	3.80 <b>5.00</b>	4.20 <b>5.50</b>	4.20 <b>5.50</b>
Capacity – rated at 110% fill factor	m <sup>3</sup> yd <sup>3</sup>	4.18 <b>5.47</b>	4.40 <b>5.75</b>	4.62 <b>6.04</b>	4.18 <b>5.47</b>	4.62 <b>6.04</b>	4.62 <b>6.04</b>
Width	mm ft/in	3220 <b>10'6"</b>	3220 <b>10'6"</b>	3220 <b>10'6"</b>	3220 <b>10'6"</b>	3220 <b>10'6"</b>	3220 <b>10'6"</b>
Dump clearance at maximum lift and 45° discharge	mm ft/in	3067 <b>10'0"</b>	3058 <b>10'0"</b>	2991 <b>9'9"</b>	3038 <b>9'11"</b>	2960 <b>9'8"</b>	2967 <b>9'8"</b>
Reach at maximum lift and 45° discharge	mm ft/in	1292 <b>4'2"</b>	1299 <b>4'3"</b>	1353 <b>4'5"</b>	1327 <b>4'4"</b>	1398 <b>4'7"</b>	1228 <b>4'0"</b>
Reach at level lift arm and bucket level	mm ft/in	2704 <b>8'10"</b>	2715 <b>8'10"</b>	2803 <b>9'2"</b>	2748 <b>9'0"</b>	2858 <b>9'4"</b>	2749 <b>9'0"</b>
Digging depth	mm in	124 <b>4.9</b>	124 <b>4.9</b>	124 <b>4.9</b>	124 <b>4.9</b>	116 <b>4.5</b>	124 <b>4.9</b>
Shipping length (With Bucket)	mm ft/in	8657 <b>28'5"</b>	8669 <b>28'6"</b>	8756 <b>28'9"</b>	8702 <b>28'7"</b>	8804 <b>28'11"</b>	8702 <b>28'7"</b>
Overall height with bucket at maximum lift	mm ft/in	5788 <b>19'0"</b>	5902 <b>19'5"</b>	5902 <b>19'5"</b>	5803 <b>19'1"</b>	5960 <b>19'7"</b>	5874 <b>19'4"</b>
Loader clearance circle with bucket at carry position	mm ft/in	14 973 <b>49'2"</b>	14 979 <b>49'2"</b>	15 022 <b>49'4"</b>	14 988 <b>49'3"</b>	15 038 <b>49'5"</b>	14 995 <b>49'3"</b>
Static tipping load, straight (with tire deflection)*	kg lb	18 475 <b>40,719</b>	18 459 <b>40,684</b>	18 247 <b>40,217</b>	17 880 <b>39,408</b>	17 595 <b>38,780</b>	18 199 <b>40,111</b>
Static tipping load, straight (no tire deflection)*	kg lb	19 797 <b>43,634</b>	19 792 <b>43,623</b>	19 570 <b>43,134</b>	19 171 <b>42,254</b>	18 884 <b>41,622</b>	19 496 <b>42,969</b>
Static tipping load, articulated (with tire deflection)*	kg lb	16 232 <b>35,777</b>	16 212 <b>35,732</b>	16 015 <b>35,299</b>	15 662 <b>34,519</b>	15 399 <b>33,940</b>	15 982 <b>35,225</b>
Static tipping load, articulated (no tire deflection)*	kg lb	17 540 <b>38,658</b>	17 531 <b>38,638</b>	17 325 <b>38,185</b>	16 944 <b>37,345</b>	16 680 <b>36,762</b>	17 266 <b>38,056</b>
Breakout force	kN lbf	187 <b>42,151</b>	185 <b>41,695</b>	173 <b>38,984</b>	180 <b>40,632</b>	166 <b>37,382</b>	180 <b>40,629</b>
Operating weight*	kg lb	23 807 <b>52,470</b>	23 859 <b>52,584</b>	23 915 <b>52,708</b>	24 224 <b>53,389</b>	24 287 <b>53,528</b>	23 869 <b>52,606</b>

\*Static tipping loads and operating weights shown are based on a machine configuration with Michelin 26.5R25 XHA2 L3 radial tires, full fluids, operator, aggregate counterweight, cold start, roading fenders, Product Link, Manual Diff Lock/Open axles (front/rear), power train guard, secondary steering and sound suppression. If a rock bucket is added, those values are with Michelin 26.5R25 XLDD2 L5 tires.

(With Tire Deflection) Full compliance to ISO 14397-1 (2007) Sections 1 thru 6, which requires 2% verification between calculations and testing.  
(No Tire Deflection) Compliance to ISO 14397-1 (2007) Sections 1 thru 5.

**NOTE:** Machine and bucket availability varies by region. Consult your local dealer for availability.

Linkage Bucket Type	Standard Linkage			Standard Linkage			High Lift Linkage Change**	
	General Purpose – Pin On							
Edge Type	Bolt-on Cutting Edges	Teeth & Segments	Tips	Bolt-on Cutting Edges	Teeth & Segments	Tips		
Capacity – rated	m <sup>3</sup> yd <sup>3</sup>	4.60 6.00	4.60 6.00	4.40 5.75	4.80 6.25	4.80 6.25	4.60 6.00	— —
Capacity – rated at 110% fill factor	m <sup>3</sup> yd <sup>3</sup>	5.06 6.62	5.06 6.62	4.84 6.33	5.28 6.91	5.28 6.91	5.06 6.62	— —
Width	mm ft/in	3220 10'6"	3271 10'8"	3271 10'8"	3220 10'6"	3271 10'8"	3271 10'8"	— —
Dump clearance at maximum lift and 45° discharge	mm ft/in	3187 10'5"	3033 9'11"	3033 9'11"	3154 10'4"	2999 9'10"	2999 9'10"	336 1'1"
Reach at maximum lift and 45° discharge	mm ft/in	1328 4'4"	1465 4'9"	1465 4'9"	1357 4'5"	1493 4'10"	1493 4'10"	23 0.9"
Reach at level lift arm and bucket level	mm ft/in	2969 9'8"	3174 10'4"	3174 10'4"	3014 9'10"	3219 10'6"	3219 10'6"	274 11"
Digging depth	mm in	103 4	103 4	73 2.8	103 4	103 4	73 2.8	-5 -0.2
Shipping length (With Bucket)	mm ft/in	9270 30'5"	9494 31'2"	9494 31'2"	9315 30'7"	9539 31'4"	9539 31'4"	335 1'1"
Overall height with bucket at maximum lift	mm ft/in	6195 20'4"	6195 20'4"	6195 20'4"	6031 19'10"	6031 19'10"	6031 19'10"	336 1'1"
Loader clearance circle with bucket at carry position	mm ft/in	15 192 49'11"	15 369 50'6"	15 369 50'6"	15 216 50'0"	15 394 50'7"	15 394 50'7"	323 1'0.7"
Static tipping load, straight (with tire deflection)*	kg lb	18 477 40,723	18 293 40,319	18 550 40,884	18 502 40,779	18 318 40,372	20 545 45,281	-1592 -3508
Static tipping load, straight (no tire deflection)*	kg lb	19 724 43,473	19 537 43,061	19 796 43,631	19 755 43,542	19 567 43,127	22 192 48,912	-1752 -3863
Static tipping load, articulated (with tire deflection)*	kg lb	16 135 35,563	15 950 35,155	16 188 35,680	16 164 35,626	15 978 35,215	17 927 39,512	-1423 -3137
Static tipping load, articulated (no tire deflection)*	kg lb	17 387 38,322	17 200 37,910	17 439 38,437	17 421 38,396	17 233 37,982	19 558 43,107	-1598 -3521
Breakout force	kN lbf	202 45,482	201 45,173	214 48,227	196 44,075	194 43,766	207 46,655	-6 -1368
Operating weight*	kg lb	24 969 55,030	25 106 55,334	24 943 54,974	24 897 54,871	25 034 55,175	24 871 54,816	84 186

\*Static tipping loads and operating weights shown are based on a machine configuration with Michelin 26.5R25 XHA2 L3 radial tires, full fluids, operator, standard counterweight, cold start, roading fenders, Product Link, Manual Diff Lock/Open axles (front/rear), power train guard, secondary steering and sound suppression.

\*\*Maximum values.

(With Tire Deflection) Full compliance to ISO 14397-1 (2007) Sections 1 thru 6, which requires 2% verification between calculations and testing.  
(No Tire Deflection) Compliance to ISO 14397-1 (2007) Sections 1 thru 5.

**NOTE:** Machine and bucket availability varies by region. Consult your local dealer for availability.

Linkage Bucket Type	Standard Linkage			Standard Linkage			High Lift Linkage Change**	
	General Purpose – Pin On			General Purpose – Fusion QC				
Edge Type	Bolt-on Cutting Edges	Teeth & Segments	Tips	Bolt-on Cutting Edges	Teeth & Segments	Tips		
Capacity – rated	m <sup>3</sup> yd <sup>3</sup>	5.00 6.50	5.00 6.50	4.80 6.25	4.40 5.75	4.40 5.75	4.20 5.50	– –
Capacity – rated at 110% fill factor	m <sup>3</sup> yd <sup>3</sup>	5.50 7.19	5.50 7.19	5.28 6.91	4.84 6.33	4.84 6.33	4.62 6.04	– –
Width	mm ft/in	3220 10'6"	3271 10'8"	3271 10'8"	3220 10'6"	3271 10'8"	3271 10'8"	– –
Dump clearance at maximum lift and 45° discharge	mm ft/in	3137 10'3"	2982 9'9"	2982 9'9"	3200 10'6"	3047 9'11"	3047 9'11"	336 1'1"
Reach at maximum lift and 45° discharge	mm ft/in	1372 4'6"	1508 4'11"	1508 4'11"	1327 4'4"	1465 4'9"	1465 4'9"	23 0.9"
Reach at level lift arm and bucket level	mm ft/in	3037 9'11"	3242 10'7"	3242 10'7"	2958 9'8"	3163 10'4"	3163 10'4"	274 11"
Digging depth	mm in	103 4	103 4	73 2.8	103 4	103 4	73 2.8	–5 –0.2
Shipping length (With Bucket)	mm ft/in	9338 30'8"	9562 31'5"	9562 31'5"	9259 30'5"	9483 31'2"	9483 31'2"	335 1'1"
Overall height with bucket at maximum lift	mm ft/in	6284 20'8"	6284 20'8"	6284 20'8"	6205 20'5"	6205 20'5"	6205 20'5"	336 1'1"
Loader clearance circle with bucket at carry position	mm ft/in	15 229 50'0"	15 407 50'7"	15 407 50'7"	15 180 49'10"	15 359 50'5"	15 359 50'5"	324 1'0.8"
Static tipping load, straight (with tire deflection)*	kg lb	18 600 40,996	18 415 40,588	18 651 41,108	18 081 39,851	17 899 39,450	18 257 40,240	–1608 –3545
Static tipping load, straight (no tire deflection)*	kg lb	19 856 43,764	19 668 43,348	19 906 43,873	19 317 42,576	19 131 42,166	19 507 42,993	–1771 –3903
Static tipping load, articulated (with tire deflection)*	kg lb	16 264 35,845	16 076 35,433	16 297 35,919	15 749 34,712	15 565 34,307	15 907 35,060	–1444 –3181
Static tipping load, articulated (no tire deflection)*	kg lb	17 521 38,617	17 332 38,200	17 553 38,687	16 992 37,452	16 807 37,043	17 163 37,828	–1620 –3570
Breakout force	kN lbf	198 44,634	197 44,325	210 47,205	203 45,788	202 45,479	216 48,572	–6 –1378
Operating weight*	kg lb	25 010 55,120	25 147 55,424	24 984 55,065	25 327 55,819	25 464 56,123	25 301 55,763	84 186

\*Static tipping loads and operating weights shown are based on a machine configuration with Michelin 26.5R25 XHA2 L3 radial tires, full fluids, operator, standard counterweight, cold start, roading fenders, Product Link, Manual Diff Lock/Open axles (front/rear), power train guard, secondary steering and sound suppression.

\*\*Maximum values.

(With Tire Deflection) Full compliance to ISO 14397-1 (2007) Sections 1 thru 6, which requires 2% verification between calculations and testing.  
(No Tire Deflection) Compliance to ISO 14397-1 (2007) Sections 1 thru 5.

**NOTE:** Machine and bucket availability varies by region. Consult your local dealer for availability.

Linkage Bucket Type	Standard Linkage				High Lift Linkage Change**	Extended Linkage		
	Material Handling — Pin On					General Purpose — Fusion QC		
Edge Type	Bolt-on Cutting Edges	Teeth & Segments	Tips		Bolt-on Cutting Edges	Teeth & Segments	Tips	
Capacity — rated	m <sup>3</sup> yd <sup>3</sup>	4.60 6.00	4.60 6.00	4.40 5.75	— —	4.90 6.41	4.90 6.41	4.70 6.15
Capacity — rated at 110% fill factor	m <sup>3</sup> yd <sup>3</sup>	5.06 6.62	5.06 6.62	4.84 6.33	— —	5.39 7.05	5.39 7.05	5.17 6.76
Width	mm ft/in	3220 10'6"	3271 10'8"	3271 10'8"	— —	3220 10'6"	3271 10'8"	3271 10'8"
Dump clearance at maximum lift and 45° discharge	mm ft/in	3120 10'2"	2957 9'8"	2957 9'8"	336 1'1"	2899 9'6"	2744 9'0"	2744 9'0"
Reach at maximum lift and 45° discharge	mm ft/in	1251 4'1"	1378 4'6"	1378 4'6"	23 0.9"	1449 4'9"	1586 5'2"	1586 5'2"
Reach at level lift arm and bucket level	mm ft/in	2979 9'9"	3184 10'5"	3184 10'5"	274 11"	2940 9'7"	3145 10'3"	3145 10'3"
Digging depth	mm in	103 4	103 4	73 2.8	-5 -0.2	115 4.5	115 4.5	85 3.3
Shipping length (With Bucket)	mm ft/in	9280 30'6"	9504 31'3"	9504 31'3"	335 1'1"	9200 30'3"	9425 31'0"	9425 31'0"
Overall height with bucket at maximum lift	mm ft/in	6162 20'3"	6162 20'3"	6162 20'3"	336 1'1"	6126 20'2"	6126 20'2"	6126 20'2"
Loader clearance circle with bucket at carry position	mm ft/in	15 197 49'11"	15 375 50'6"	15 375 50' 6"	334 1'1"	15 081 49'6"	15 255 50'1"	15 255 50'1"
Static tipping load, straight (with tire deflection)*	kg lb	18 412 40,580	18 229 40,177	18 468 40,704	-1598 -3521	19 411 42,781	19 225 42,372	19 590 43,177
Static tipping load, straight (no tire deflection)*	kg lb	19 640 43,286	19 453 42,875	19 695 43,409	-1757 -3871	20 885 46,032	20 695 45,612	21 079 46,460
Static tipping load, articulated (with tire deflection)*	kg lb	16 081 35,442	15 896 35,035	16 119 35,526	-1429 -3149	16 920 37,293	16 732 36,878	17 082 37,649
Static tipping load, articulated (no tire deflection)*	kg lb	17 313 38,159	17 127 37,749	17 351 38,242	-1601 -3528	18 387 40,526	18 197 40,106	18 562 40,912
Breakout force	kN lbf	201 45,174	199 44,865	213 47,882	-7 -1647	198 44,570	196 44,204	209 47,022
Operating weight*	kg lb	24 964 55,019	25 101 55,323	24 938 54,963	85 186	25 283 55,724	25 421 56,028	25 258 55,668

\*Static tipping loads and operating weights shown are based on a machine configuration with Michelin 26.5R25 XHA2 L3 radial tires, full fluids, operator, standard counterweight, cold start, roading fenders, Product Link, Manual Diff Lock/Open axles (front/rear), power train guard, secondary steering and sound suppression.

\*\*Maximum values.

(With Tire Deflection) Full compliance to ISO 14397-1 (2007) Sections 1 thru 6, which requires 2% verification between calculations and testing.  
(No Tire Deflection) Compliance to ISO 14397-1 (2007) Sections 1 thru 5.

**NOTE:** Machine and bucket availability varies by region. Consult your local dealer for availability.

Package		Aggregate Handler		
Bucket Type		General Purpose — Fusion QC		
Edge Type		Bolt-on Cutting Edges	Bolt-on Cutting Edges	Bolt-on Cutting Edges
Capacity — rated	m <sup>3</sup>	5.10	5.30	5.50
	yd <sup>3</sup>	<b>6.67</b>	<b>6.93</b>	<b>7.19</b>
Capacity — rated at 110% fill factor	m <sup>3</sup>	5.61	5.83	6.05
	yd <sup>3</sup>	<b>7.34</b>	<b>7.63</b>	<b>7.91</b>
Width	mm	3357	3357	3357
	ft/in	<b>11'0"</b>	<b>11'0"</b>	<b>11'0"</b>
Dump clearance at maximum lift and 45° discharge	mm	3127	3100	3072
	ft/in	<b>10'3"</b>	<b>10'2"</b>	<b>10'0"</b>
Reach at maximum lift and 45° discharge	mm	1375	1399	1424
	ft/in	<b>4'6"</b>	<b>4'7"</b>	<b>4'8"</b>
Reach at level lift arm and bucket level	mm	3046	3083	3121
	ft/in	<b>9'11"</b>	<b>10'1"</b>	<b>10'2"</b>
Digging depth	mm	108	108	108
	in	<b>4.2</b>	<b>4.2</b>	<b>4.2</b>
Shipping length (With Bucket)	mm	9037	9074	9112
	ft/in	<b>29'8"</b>	<b>29'10"</b>	<b>29'11"</b>
Overall height with bucket at maximum lift	mm	6235	6272	6293
	ft/in	<b>20'6"</b>	<b>20'7"</b>	<b>20'8"</b>
Loader clearance circle with bucket at carry position	mm	15 362	15 382	15 403
	ft/in	<b>50'5"</b>	<b>50'6"</b>	<b>50'7"</b>
Static tipping load, straight (with tire deflection)*	kg	19 316	19 242	19 172
	lb	<b>42,574</b>	<b>42,409</b>	<b>42,255</b>
Static tipping load, straight (no tire deflection)*	kg	20 669	20 600	20 537
	lb	<b>45,556</b>	<b>45,403</b>	<b>45,263</b>
Static tipping load, articulated (with tire deflection)*	kg	16 799	16 726	16 658
	lb	<b>37,026</b>	<b>36,865</b>	<b>36,716</b>
Static tipping load, articulated (no tire deflection)*	kg	18 165	18 098	18 036
	lb	<b>40,036</b>	<b>39,888</b>	<b>39,753</b>
Breakout force	kN	190	185	180
	lbf	<b>42,755</b>	<b>41,650</b>	<b>40,573</b>
Operating weight*	kg	25 790	25 832	25 870
	lb	<b>56,840</b>	<b>56,933</b>	<b>57,016</b>

\*Static tipping loads and operating weights shown are based on a machine configuration with Michelin 26.5R25 XHA2 L3 radial tires, full fluids, operator, standard counterweight, cold start, roading fenders, Product Link, Manual Diff Lock/Open axles (front/rear), power train guard, secondary steering and sound suppression.

(With Tire Deflection) Full compliance to ISO 14397-1 (2007) Sections 1 thru 6, which requires 2% verification between calculations and testing.

(No Tire Deflection) Compliance to ISO 14397-1 (2007) Sections 1 thru 5.

**NOTE:** Machine and bucket availability varies by region. Consult your local dealer for availability.

Bucket Type		General Purpose – Pin On			Rock – Pin On**			Coal – Pin On	High Lift Delta	
		Bolt-on Cutting Edges	Teeth & Segments	Tips	Bolt-on Cutting Edges	Teeth & Segments	Tips	Bolt-on Cutting Edges		
Edge Type	Capacity — rated	m <sup>3</sup>	5.40	5.40	5.00	4.40	4.40	4.30	8.20	—
		yd <sup>3</sup>	<b>7.06</b>	<b>7.06</b>	<b>6.54</b>	<b>5.75</b>	<b>5.75</b>	<b>5.62</b>	<b>10.73</b>	—
Capacity — 110%		m <sup>3</sup>	5.94	5.94	5.50	4.84	4.84	4.73	9.02	—
		yd <sup>3</sup>	<b>7.77</b>	<b>7.77</b>	<b>7.19</b>	<b>6.33</b>	<b>6.33</b>	<b>6.19</b>	<b>11.80</b>	—
Width		mm	3447	3535	3535	3504	3504	3504	3638	—
		ft/in	<b>11'3"</b>	<b>11'7"</b>	<b>11'7"</b>	<b>11'5"</b>	<b>11'5"</b>	<b>11'5"</b>	<b>11'11"</b>	—
Dump clearance at maximum lift and 45° discharge		mm	3273	3107	3107	3101	3101	3101	2917	221
		ft/in	<b>10'8"</b>	<b>10'2"</b>	<b>10'2"</b>	<b>10'2"</b>	<b>10'2"</b>	<b>10'2"</b>	<b>9'6"</b>	<b>8"</b>
Reach at maximum lift and 45° discharge		mm	1481	1618	1618	1769	1769	1769	1625	—
		ft/in	<b>4'10"</b>	<b>5'3"</b>	<b>5'3"</b>	<b>5'9"</b>	<b>5'9"</b>	<b>5'9"</b>	<b>5'3"</b>	—
Reach at level lift arm and bucket level		mm	2965	3177	3177	3285	3285	3285	3336	160
		ft/in	<b>9'8"</b>	<b>10'5"</b>	<b>10'5"</b>	<b>10'9"</b>	<b>10'9"</b>	<b>10'9"</b>	<b>10'11"</b>	<b>6"</b>
Digging depth		mm	103	103	68	106	106	71	108	—
		in	<b>4.0</b>	<b>4.0</b>	<b>2.6</b>	<b>4.1</b>	<b>4.1</b>	<b>2.8</b>	<b>4.2</b>	—
Overall length		mm	9493	9734	9734	9828	9828	9828	9876	201
		ft/in	<b>31'2"</b>	<b>32'0"</b>	<b>32'0"</b>	<b>32'3"</b>	<b>32'3"</b>	<b>32'3"</b>	<b>32'5"</b>	<b>7"</b>
Overall height with bucket at maximum lift		mm	6421	6421	6421	6184	6184	6184	6536	221
		ft/in	<b>21'1"</b>	<b>21'1"</b>	<b>21'1"</b>	<b>20'4"</b>	<b>20'4"</b>	<b>20'4"</b>	<b>21'6"</b>	<b>8"</b>
Loader clearance circle with bucket at carry position		mm	15 223	15 451	15 451	15 469	15 469	15 469	15 609	1009
		ft/in	<b>50'0"</b>	<b>50'9"</b>	<b>50'9"</b>	<b>50'10"</b>	<b>50'9"</b>	<b>50'9"</b>	<b>51'3"</b>	<b>3'3"</b>
Static tipping load, straight (ISO)*		kg	22 639	22 453	22 897	22 987	23 033	23 504	21 615	-2002
		lb	<b>49,897</b>	<b>49,488</b>	<b>50,466</b>	<b>50,664</b>	<b>50,766</b>	<b>51,803</b>	<b>47,639</b>	<b>-4413</b>
Static tipping load, straight (rigid tire)*		kg	24 023	23 835	24 297	24 375	24 431	24 912	23 054	-2212
		lb	<b>52,946</b>	<b>52,533</b>	<b>53,551</b>	<b>53,722</b>	<b>53,848</b>	<b>54,907</b>	<b>50,811</b>	<b>-4875</b>
Static tipping load, articulated (ISO)*		kg	19 565	19 379	19 795	19 851	19 875	20 337	18 575	-1365
		lb	<b>43,121</b>	<b>42,712</b>	<b>43,629</b>	<b>43,752</b>	<b>43,806</b>	<b>44,822</b>	<b>40,941</b>	<b>-3008</b>
Static tipping load, articulated (rigid tire)*		kg	20 796	20 608	21 040	21 083	21 117	21 587	19 864	-1547
		lb	<b>45,834</b>	<b>45,421</b>	<b>46,373</b>	<b>46,467</b>	<b>46,542</b>	<b>47,578</b>	<b>43,781</b>	<b>-3410</b>
Breakout force (§)		kN	224	222	239	210	210	227	175	19
		lbf	<b>50,466</b>	<b>49,926</b>	<b>53,816</b>	<b>47,384</b>	<b>47,195</b>	<b>51,049</b>	<b>39,467</b>	<b>4190</b>
Operating weight*		kg	30 090	30 228	30 053	30 612	30 687	30 392	30 677	115
		lb	<b>66,318</b>	<b>66,623</b>	<b>66,236</b>	<b>67,469</b>	<b>67,634</b>	<b>66,984</b>	<b>67,612</b>	<b>253</b>

\*Static tipping loads and operating weights shown are based on a machine configuration with Michelin 29.5R25 XLDD1 L4 radial tires, full fluids, operator, standard counterweight, cold start, roading fenders, Product Link, limited slip differentials, power train guard, secondary steering and sound suppression.

\*\*Rock bucket specifications are given on Michelin 29.5R25 XLDD2 L5 Radial tires.

(§) Measured 102 mm (4") behind tip of cutting edge with bucket hinge pin as pivot point in accordance with SAE J732C.

(§) Specifications and ratings conform to all applicable standards recommended by the Society of Automotive Engineers, including SAE Standard J732C governing loader ratings.

(ISO) Full compliance to ISO 14397-1 (2007) Sections 1 thru 6, which requires 2% verification between calculations and testing.

(Rigid Tire) Compliance to ISO 14397-1 (2007) Sections 1 thru 5.

**NOTE:** Machine and bucket availability varies by region. Consult your local dealer for availability.

Bucket Type	General Purpose – Pin On		Material Handling – Pin On	Coal – Pin On
	Bolt-on Cutting Edges	Bolt-on Cutting Edges	Bolt-on Cutting Edges	Bolt-on Cutting Edges
Capacity – rated	m <sup>3</sup>	5.70	6.00	5.70
	yd <sup>3</sup>	<b>7.46</b>	<b>7.85</b>	<b>7.46</b>
Capacity – 110%	m <sup>3</sup>	6.27	6.60	6.27
	yd <sup>3</sup>	<b>8.20</b>	<b>8.63</b>	<b>8.20</b>
Width	mm	3447	3447	3447
	ft/in	<b>11'3"</b>	<b>11'3"</b>	<b>11'3"</b>
Dump clearance at maximum lift and 45° discharge	mm	3204	3187	3105
	ft/in	<b>10'6"</b>	<b>10'5"</b>	<b>10'2"</b>
Reach at maximum lift and 45° discharge	mm	1529	1550	1444
	ft/in	<b>5'0"</b>	<b>5'1"</b>	<b>4'8"</b>
Reach at level lift arm and bucket level	mm	3049	3077	3074
	ft/in	<b>10'0"</b>	<b>10'1"</b>	<b>10'1"</b>
Digging depth	mm	103	103	103
	in	<b>4</b>	<b>4</b>	<b>4</b>
Overall length	mm	9638	9666	9663
	ft/in	<b>31'8"</b>	<b>31'9"</b>	<b>31'9"</b>
Overall height with bucket at maximum lift	mm	6243	6269	6242
	ft/in	<b>20'6"</b>	<b>20'7"</b>	<b>20'6"</b>
Loader clearance circle with bucket at carry position	mm	15 270	15 285	15 284
	ft/in	<b>50'2"</b>	<b>50'2"</b>	<b>50'2"</b>
Static tipping load, straight (ISO)*	kg	23 972	23 827	23 447
	lb	<b>52,835</b>	<b>52,515</b>	<b>51,677</b>
Static tipping load, straight (rigid tire)*	kg	25 481	25 339	24 909
	lb	<b>56,161</b>	<b>55,847</b>	<b>54,901</b>
Static tipping load, articulated (ISO)*	kg	20 630	20 491	20 163
	lb	<b>45,470</b>	<b>45,162</b>	<b>44,440</b>
Static tipping load, articulated (rigid tire)*	kg	21 997	21 860	21 488
	lb	<b>48,482</b>	<b>48,180</b>	<b>47,360</b>
Breakout force (§)	kN	211	207	208
	lbf	<b>47,618</b>	<b>46,676</b>	<b>46,782</b>
Operating weight*	kg	30 822	30 918	30 947
	lb	<b>67,931</b>	<b>68,143</b>	<b>68,207</b>

\*Static tipping loads and operating weights shown are based on a machine configuration with Michelin 29.5R25 XLDD1 L4 radial tires, full fluids, operator, aggregate counterweight, cold start, roading fenders, Product Link, limited slip differentials, power train guard, secondary steering and sound suppression. If a rock bucket is added, those values are with Michelin 26.5R25 XLDD2 L5 tires.

\*\*Aggregate Handler configuration is not compatible with teeth and segments, tips, rock buckets, high lift, L5 tires.

(§) Measured 102 mm (4") behind tip of cutting edge with bucket hinge pin as pivot point in accordance with SAE J732C.

(§) Specifications and ratings conform to all applicable standards recommended by the Society of Automotive Engineers, including SAE Standard J732C governing loader ratings.

(ISO) Full compliance to ISO 14397-1 (2007) Sections 1 thru 6, which requires 2% verification between calculations and testing.

(Rigid Tire) Compliance to ISO 14397-1 (2007) Sections 1 thru 5.

**NOTE:** Machine and bucket availability varies by region. Consult your local dealer for availability.

Bucket Type	General Purpose						
		Bolt-on Cutting Edges	Teeth & Segments	Tips	Bolt-on Cutting Edges	Teeth & Segments	Tips
Edge Type							
Capacity — rated	m <sup>3</sup> yd <sup>3</sup>	6.10 <b>7.98</b>	6.10 <b>7.98</b>	5.70 <b>7.46</b>	6.40 <b>8.37</b>	6.40 <b>8.37</b>	6.10 <b>7.98</b>
Capacity — 110%	m <sup>3</sup> yd <sup>3</sup>	6.71 <b>8.78</b>	6.71 <b>8.78</b>	6.27 <b>8.20</b>	7.04 <b>9.21</b>	7.04 <b>9.21</b>	6.71 <b>8.78</b>
Width	mm ft/in	3602 <b>11'9"</b>	3665 <b>12'0"</b>	3665 <b>12'0"</b>	3602 <b>11'9"</b>	3665 <b>12'0"</b>	3665 <b>12'0"</b>
Dump clearance at maximum lift and 45° discharge	mm ft/in	3365 <b>11'0"</b>	3197 <b>10'5"</b>	3197 <b>10'5"</b>	3327 <b>10'11"</b>	3159 <b>10'4"</b>	3159 <b>10'4"</b>
Reach at maximum lift and 45° discharge	mm ft/in	1569 <b>5'1"</b>	1703 <b>5'7"</b>	1703 <b>5'7"</b>	1602 <b>5'3"</b>	1735 <b>5'8"</b>	1735 <b>5'8"</b>
Reach at level lift arm and bucket level	mm ft/in	3257 <b>10'8"</b>	3468 <b>11'4"</b>	3468 <b>11'4"</b>	3307 <b>10'10"</b>	3518 <b>11'6"</b>	3518 <b>11'6"</b>
Digging depth	mm in	116 <b>4.5</b>	116 <b>4.5</b>	81 <b>3.2</b>	116 <b>4.5</b>	116 <b>4.5</b>	81 <b>3.2</b>
Overall length	mm ft/in	10 178 <b>33'5"</b>	10 412 <b>34'2"</b>	10 412 <b>34'2"</b>	10 228 <b>33'7"</b>	10 462 <b>34'4"</b>	10 462 <b>34'4"</b>
Overall height with bucket at maximum lift	mm ft/in	6592 <b>21'8"</b>	6592 <b>21'8"</b>	6592 <b>21'8"</b>	6642 <b>21'10"</b>	6642 <b>21'10"</b>	6642 <b>21'10"</b>
Loader clearance circle with bucket at carry position	mm ft/in	15 770 <b>51'9"</b>	15 986 <b>52'6"</b>	15 986 <b>52'6"</b>	15 801 <b>51'11"</b>	16 018 <b>52'7"</b>	16 018 <b>52'7"</b>
Static tipping load, straight (ISO)*	kg lb	24 791 <b>54,640</b>	24 692 <b>54,422</b>	25 112 <b>55,347</b>	24 620 <b>54,264</b>	24 521 <b>54,045</b>	24 952 <b>54,994</b>
Static tipping load, straight (rigid tire)*	kg lb	26 101 <b>57,527</b>	26 001 <b>57,308</b>	26 439 <b>58,272</b>	25 938 <b>57,169</b>	25 838 <b>56,948</b>	26 285 <b>57,933</b>
Static tipping load, articulated (ISO)*	kg lb	21 080 <b>46,462</b>	20 981 <b>46,243</b>	21 370 <b>47,100</b>	20 918 <b>46,105</b>	20 819 <b>45,885</b>	21 217 <b>46,763</b>
Static tipping load, articulated (rigid tire)*	kg lb	22 393 <b>49,354</b>	22 293 <b>49,135</b>	22 699 <b>50,029</b>	22 239 <b>49,015</b>	22 138 <b>48,794</b>	22 552 <b>49,706</b>
Breakout force (§)	kN lbf	260 <b>58,531</b>	259 <b>58,375</b>	278 <b>62,671</b>	251 <b>56,572</b>	251 <b>56,417</b>	269 <b>60,459</b>
Operating weight*	kg lb	35 563 <b>78,382</b>	35 636 <b>78,542</b>	35 476 <b>78,189</b>	35 655 <b>78,583</b>	35 727 <b>78,742</b>	35 567 <b>78,389</b>

\*Static tipping loads and operating weights shown are based on a machine configuration with Bridgestone 875/65R29 VLTS L4 radial tires, full fluids, operator, standard counterweight, cold start, roading fenders, Product Link, limited slip differentials, power train guard, secondary steering and sound suppression.

(§) Measured 102 mm (4") behind tip of cutting edge with bucket hinge pin as pivot point in accordance with SAE J732C.

(§) Specifications and ratings conform to all applicable standards recommended by the Society of Automotive Engineers, including SAE Standard J732C governing loader ratings.

(ISO) Full compliance to ISO 14397-1 (2007) Sections 1 thru 6, which requires 2% verification between calculations and testing.

(Rigid Tire) Compliance to ISO 14397-1 (2007) Sections 1 thru 5.

**NOTE:** Machine and bucket availability varies by region. Consult your local dealer for availability.



Bucket Type		Heavy Duty Rock			Woodchip	Coal
		Bolt-on Cutting Edges	Teeth & Segments	Tips	Bolt-on Cutting Edges	Bolt-on Cutting Edges
Edge Type						
Capacity — rated	m <sup>3</sup>	5.40	5.40	5.10	12.00	8.80
	yd <sup>3</sup>	<b>7.06</b>	<b>7.06</b>	<b>6.67</b>	<b>15.70</b>	<b>11.51</b>
Capacity — 110%	m <sup>3</sup>	5.94	5.94	5.61	13.20	9.68
	yd <sup>3</sup>	<b>7.77</b>	<b>7.77</b>	<b>7.34</b>	<b>17.26</b>	<b>12.66</b>
Width	mm	3648	3648	3648	4174	3639
	ft/in	<b>11'11"</b>	<b>11'11"</b>	<b>11'11"</b>	<b>13'8"</b>	<b>11'11"</b>
Dump clearance at maximum lift and 45° discharge	mm	3253	3136	3136	3022	3017
	ft/in	<b>10'8"</b>	<b>10'3"</b>	<b>10'3"</b>	<b>9'10"</b>	<b>9'10"</b>
Reach at maximum lift and 45° discharge	mm	1794	1915	1915	1738	1743
	ft/in	<b>5'10"</b>	<b>6'3"</b>	<b>6'3"</b>	<b>5'8"</b>	<b>5'8"</b>
Reach at level lift arm and bucket level	mm	3489	3657	3657	3638	3645
	ft/in	<b>11'5"</b>	<b>11'11"</b>	<b>11'11"</b>	<b>11'11"</b>	<b>11'11"</b>
Digging depth	mm	107	107	72	119	119
	in	<b>4.2</b>	<b>4.2</b>	<b>2.8</b>	<b>4.7</b>	<b>4.7</b>
Overall length	mm	10 410	10 586	10 586	10 561	10 568
	ft/in	<b>34'2"</b>	<b>34'9"</b>	<b>34'9"</b>	<b>34'8"</b>	<b>34'9"</b>
Overall height with bucket at maximum lift	mm	6540	6540	6540	7059	6962
	ft/in	<b>21'6"</b>	<b>21'6"</b>	<b>21'6"</b>	<b>23'2"</b>	<b>22'11"</b>
Loader clearance circle with bucket at carry position	mm	15 955	16 073	16 073	16 516	16 049
	ft/in	<b>52'5"</b>	<b>52'9"</b>	<b>52'9"</b>	<b>54'3"</b>	<b>52'8"</b>
Static tipping load, straight (ISO)*	kg	23 940	23 809	24 303	23 472	23 229
	lb	<b>52,764</b>	<b>52,475</b>	<b>53,565</b>	<b>51,734</b>	<b>51,198</b>
Static tipping load, straight (rigid tire)*	kg	25 241	25 108	25 614	24 881	24 545
	lb	<b>55,631</b>	<b>55,339</b>	<b>56,454</b>	<b>54,838</b>	<b>54,098</b>
Static tipping load, articulated (ISO)*	kg	20 193	20 062	20 537	19 784	19 630
	lb	<b>44,505</b>	<b>44,217</b>	<b>45,264</b>	<b>43,605</b>	<b>43,264</b>
Static tipping load, articulated (rigid tire)*	kg	21 497	21 364	21 851	21 191	20 949
	lb	<b>47,380</b>	<b>47,088</b>	<b>48,160</b>	<b>46,706</b>	<b>46,172</b>
Breakout force (§)	kN	233	232	249	203	203
	lbf	<b>52,456</b>	<b>52,261</b>	<b>56,145</b>	<b>45,653</b>	<b>45,761</b>
Operating weight*	kg	36 601	36 694	36 420	36 512	36 233
	lb	<b>80,669</b>	<b>80,874</b>	<b>80,270</b>	<b>80,473</b>	<b>79,858</b>

\*Static tipping loads and operating weights shown are based on a machine configuration with Bridgestone 875/65R29 VLTS L4 radial tires, full fluids, operator, standard counterweight, cold start, roading fenders, Product Link, limited slip differentials, power train guard, secondary steering and sound suppression.

(§) Measured 102 mm (4") behind tip of cutting edge with bucket hinge pin as pivot point in accordance with SAE J732C.

(§) Specifications and ratings conform to all applicable standards recommended by the Society of Automotive Engineers, including SAE Standard J732C governing loader ratings.

(ISO) Full compliance to ISO 14397-1 (2007) Sections 1 thru 6, which requires 2% verification between calculations and testing.

(Rigid Tire) Compliance to ISO 14397-1 (2007) Sections 1 thru 5.

**NOTE:** Machine and bucket availability varies by region. Consult your local dealer for availability.

Bucket Type		General Purpose				General Purpose – Heavy Duty
		Bolt-on Cutting Edges	Bolt-on Cutting Edges	Bolt-on Cutting Edges	Bolt-on Cutting Edges	Bolt-on Cutting Edges
Edge Type						
Capacity — rated	m <sup>3</sup>	6.40	7.00	7.50	8.20	7.50
	yd <sup>3</sup>	<b>8.37</b>	<b>9.16</b>	<b>9.81</b>	<b>10.73</b>	<b>9.81</b>
Capacity — 110%	m <sup>3</sup>	7.04	7.70	8.25	9.02	8.25
	yd <sup>3</sup>	<b>9.21</b>	<b>10.07</b>	<b>10.79</b>	<b>11.80</b>	<b>10.79</b>
Width	mm	3602	3602	3602	3602	3602
	ft/in	<b>11'9"</b>	<b>11'9"</b>	<b>11'9"</b>	<b>11'9"</b>	<b>11'9"</b>
Dump clearance at maximum lift and 45° discharge	mm	3327	3277	3227	3154	3236
	ft/in	<b>10'11"</b>	<b>10'9"</b>	<b>10'7"</b>	<b>10'4"</b>	<b>10'7"</b>
Reach at maximum lift and 45° discharge	mm	1602	1644	1689	1755	1697
	ft/in	<b>5'3"</b>	<b>5'4"</b>	<b>5'6"</b>	<b>5'9"</b>	<b>5'6"</b>
Reach at level lift arm and bucket level	mm	3307	3374	3442	3542	3442
	ft/in	<b>10'10"</b>	<b>11'0"</b>	<b>11'3"</b>	<b>11'7"</b>	<b>11'3"</b>
Digging depth	mm	116	116	116	116	104
	in	<b>4.5</b>	<b>4.5</b>	<b>4.5</b>	<b>4.5</b>	<b>4.1</b>
Overall length	mm	10 335	10 402	10 470	10 570	10 462
	ft/in	<b>33'11"</b>	<b>34'2"</b>	<b>34'5"</b>	<b>34'9"</b>	<b>34'4"</b>
Overall height with bucket at maximum lift	mm	6642	6709	6776	6870	6779
	ft/in	<b>21'10"</b>	<b>22'1"</b>	<b>22'3"</b>	<b>22'7"</b>	<b>22'3"</b>
Loader clearance circle with bucket at carry position	mm	15 801	15 842	15 885	15 948	15 876
	ft/in	<b>51'11"</b>	<b>52'0"</b>	<b>52'2"</b>	<b>52'4"</b>	<b>52'2"</b>
Static tipping load, straight (ISO)*	kg	26 038	25 761	25 552	25 217	24 863
	lb	<b>57,389</b>	<b>56,779</b>	<b>56,316</b>	<b>55,578</b>	<b>54,799</b>
Static tipping load, straight (rigid tire)*	kg	27 454	27 186	26 985	26 661	26 293
	lb	<b>60,510</b>	<b>59,918</b>	<b>59,475</b>	<b>58,762</b>	<b>57,949</b>
Static tipping load, articulated (ISO)*	kg	22 083	21 816	21 618	21 299	20 924
	lb	<b>48,672</b>	<b>48,084</b>	<b>47,647</b>	<b>46,944</b>	<b>46,116</b>
Static tipping load, articulated (rigid tire)*	kg	23 507	23 249	23 058	22 751	22 361
	lb	<b>51,809</b>	<b>51,240</b>	<b>50,821</b>	<b>50,144</b>	<b>49,283</b>
Breakout force (§)	kN	251	240	230	216	227
	lbf	<b>56,572</b>	<b>54,068</b>	<b>51,768</b>	<b>48,643</b>	<b>51,178</b>
Operating weight*	kg	36 302	36 483	36 589	36 774	37 265
	lb	<b>80,009</b>	<b>80,408</b>	<b>80,641</b>	<b>81,049</b>	<b>82,131</b>

\*Static tipping loads and operating weights shown are based on a machine configuration with Bridgestone 875/65R29 VLTS L4 radial tires, full fluids, operator, aggregate counterweight, cold start, roading fenders, Product Link, limited slip differentials, power train guard, secondary steering and sound suppression.

\*\*Aggregate Handler configuration is not compatible with teeth and segments, tips, rock buckets, high lift, L5 tires.

(§) Measured 102 mm (4") behind tip of cutting edge with bucket hinge pin as pivot point in accordance with SAE J732C.

(§) Specifications and ratings conform to all applicable standards recommended by the Society of Automotive Engineers, including SAE Standard J732C governing loader ratings.

(ISO) Full compliance to ISO 14397-1 (2007) Sections 1 thru 6, which requires 2% verification between calculations and testing.

(Rigid Tire) Compliance to ISO 14397-1 (2007) Sections 1 thru 5.

**NOTE:** Machine and bucket availability varies by region. Consult your local dealer for availability.

Bucket Type	Material Handling — Heavy Duty		Woodchip	Coal	
	Bolt-on Cutting Edges	Bolt-on Cutting Edges	Bolt-on Cutting Edges	Bolt-on Cutting Edges	
Edge Type					
Capacity — rated	m <sup>3</sup> yd <sup>3</sup>	6.40 <b>8.37</b>	7.00 <b>9.16</b>	12.00 <b>15.70</b>	8.80 <b>11.51</b>
Capacity — 110%	m <sup>3</sup> yd <sup>3</sup>	7.04 <b>9.21</b>	7.70 <b>10.07</b>	13.20 <b>17.26</b>	9.68 <b>12.66</b>
Width	mm ft/in	3602 <b>11'9"</b>	3602 <b>11'9"</b>	4174 <b>13'8"</b>	3639 <b>11'11"</b>
Dump clearance at maximum lift and 45° discharge	mm ft/in	3264 <b>10'8"</b>	3200 <b>10'6"</b>	3022 <b>9'10"</b>	3017 <b>9'10"</b>
Reach at maximum lift and 45° discharge	mm ft/in	1518 <b>4'11"</b>	1581 <b>5'2"</b>	1738 <b>5'8"</b>	1743 <b>5'8"</b>
Reach at level lift arm and bucket level	mm ft/in	3311 <b>10'10"</b>	3401 <b>11'1"</b>	3638 <b>11'11"</b>	3645 <b>11'11"</b>
Digging depth	mm in	104 <b>4.1</b>	104 <b>4.1</b>	119 <b>4.7</b>	119 <b>4.7</b>
Overall length	mm ft/in	10 331 <b>33'11"</b>	10 421 <b>34'3"</b>	10 668 <b>35'0"</b>	10 675 <b>35'1"</b>
Overall height with bucket at maximum lift	mm ft/in	6622 <b>21'9"</b>	6709 <b>22'1"</b>	7059 <b>23'2"</b>	6962 <b>22'11"</b>
Loader clearance circle with bucket at carry position	mm ft/in	15 794 <b>51'10"</b>	15 850 <b>52'0"</b>	16 516 <b>54'3"</b>	16 049 <b>52'8"</b>
Static tipping load, straight (ISO)*	kg lb	24 813 <b>54,689</b>	24 471 <b>53,935</b>	24 878 <b>54,831</b>	24 604 <b>54,228</b>
Static tipping load, straight (rigid tire)*	kg lb	26 181 <b>57,704</b>	25 850 <b>56,973</b>	26 392 <b>58,170</b>	26 018 <b>57,344</b>
Static tipping load, articulated (ISO)*	kg lb	20 907 <b>46,079</b>	20 578 <b>45,354</b>	20 937 <b>46,145</b>	20 758 <b>45,751</b>
Static tipping load, articulated (rigid tire)*	kg lb	22 285 <b>49,116</b>	21 966 <b>48,414</b>	22 456 <b>49,493</b>	22 181 <b>48,888</b>
Breakout force (§)	kN lbf	247 <b>55,612</b>	232 <b>52,320</b>	203 <b>45,653</b>	203 <b>45,761</b>
Operating weight*	kg lb	37 148 <b>81,873</b>	37 355 <b>82,330</b>	37 159 <b>81,899</b>	36 880 <b>81,284</b>

\*Static tipping loads and operating weights shown are based on a machine configuration with Bridgestone 875/65R29 VLTS L4 radial tires, full fluids, operator, aggregate counterweight, cold start, roading fenders, Product Link, limited slip differentials, power train guard, secondary steering and sound suppression.

\*\*Aggregate Handler configuration is not compatible with teeth and segments, tips, rock buckets, high lift, L5 tires.

(§) Measured 102 mm (4") behind tip of cutting edge with bucket hinge pin as pivot point in accordance with SAE J732C.

(§) Specifications and ratings conform to all applicable standards recommended by the Society of Automotive Engineers, including SAE Standard J732C governing loader ratings.

(ISO) Full compliance to ISO 14397-1 (2007) Sections 1 thru 6, which requires 2% verification between calculations and testing.

(Rigid Tire) Compliance to ISO 14397-1 (2007) Sections 1 thru 5.

**NOTE:** Machine and bucket availability varies by region. Consult your local dealer for availability.

Bucket Type	General Purpose — Pin On									
		Bolt-on Cutting Edges	Teeth & Segments	Teeth	Bolt-on Cutting Edges	Teeth & Segments	Teeth	Bolt-on Cutting Edges	Teeth & Segments	Teeth
Edge Type										
Capacity — rated (§)	m <sup>3</sup>	2.70	2.70	2.50	2.90	2.90	2.70	3.10	3.10	2.90
	yd <sup>3</sup>	<b>3.53</b>	<b>3.53</b>	<b>3.27</b>	<b>3.79</b>	<b>3.79</b>	<b>3.53</b>	<b>4.05</b>	<b>4.05</b>	<b>3.79</b>
Capacity — struck (§)	m <sup>3</sup>	2.30	2.30	2.11	2.55	2.55	2.33	2.76	2.76	2.54
	yd <sup>3</sup>	<b>3.01</b>	<b>3.01</b>	<b>2.76</b>	<b>3.34</b>	<b>3.34</b>	<b>3.05</b>	<b>3.61</b>	<b>3.61</b>	<b>3.32</b>
Width (§)	mm	2927	2994	2994	2927	2994	2994	2927	2994	2994
	ft/in	<b>9'7"</b>	<b>9'9"</b>	<b>9'9"</b>	<b>9'7"</b>	<b>9'9"</b>	<b>9'9"</b>	<b>9'7"</b>	<b>9'9"</b>	<b>9'9"</b>
Dump clearance at maximum lift and 45° discharge (§)	mm	2975	2859	2859	2919	2802	2802	2876	2758	2758
	ft/in	<b>9'9"</b>	<b>9'4"</b>	<b>9'4"</b>	<b>9'6"</b>	<b>9'2"</b>	<b>9'2"</b>	<b>9'5"</b>	<b>9'0"</b>	<b>9'0"</b>
Reach at maximum lift and 45° discharge (§)	mm	1356	1469	1469	1395	1506	1506	1429	1540	1540
	ft/in	<b>4'5"</b>	<b>4'9"</b>	<b>4'9"</b>	<b>4'6"</b>	<b>4'11"</b>	<b>4'11"</b>	<b>4'8"</b>	<b>5'0"</b>	<b>5'0"</b>
Reach at level lift arm and bucket level (§)	mm	2562	2723	2723	2631	2792	2792	2688	2849	2849
	ft/in	<b>8'4"</b>	<b>8'11"</b>	<b>8'11"</b>	<b>8'7"</b>	<b>9'1"</b>	<b>9'1"</b>	<b>8'9"</b>	<b>9'4"</b>	<b>9'4"</b>
Digging depth (§)	mm	90	90	60	90	90	60	90	90	60
	in	<b>3.5</b>	<b>3.5</b>	<b>2.3</b>	<b>3.5</b>	<b>3.5</b>	<b>2.3</b>	<b>3.5</b>	<b>3.5</b>	<b>2.3</b>
Overall length	mm	8036	8209	8209	8105	8278	8278	8162	8335	8335
	ft/in	<b>26'5"</b>	<b>27'0"</b>	<b>27'0"</b>	<b>26'8"</b>	<b>27'2"</b>	<b>27'2"</b>	<b>26'10"</b>	<b>27'5"</b>	<b>27'5"</b>
Overall height with bucket at maximum lift	mm	5392	5392	5392	5464	5464	5464	5525	5525	5525
	ft/in	<b>17'9"</b>	<b>17'9"</b>	<b>17'9"</b>	<b>18'0"</b>	<b>18'0"</b>	<b>18'0"</b>	<b>18'2"</b>	<b>18'2"</b>	<b>18'2"</b>
Loader clearance circle with bucket at carry position (§)	mm	13 689	13 856	13 856	13 729	13 897	13 897	13 762	13 931	13 931
	ft/in	<b>44'11"</b>	<b>45'6"</b>	<b>45'6"</b>	<b>45'1"</b>	<b>45'8"</b>	<b>45'8"</b>	<b>45'2"</b>	<b>45'9"</b>	<b>45'9"</b>
Static tipping load, straight (ISO)*	kg	12 974	12 836	13 135	12 833	12 694	12 985	12 740	12 600	12 883
	lb	<b>28,596</b>	<b>28,291</b>	<b>28,949</b>	<b>28,285</b>	<b>27,977</b>	<b>28,619</b>	<b>28,081</b>	<b>27,770</b>	<b>28,394</b>
Static tipping load, straight (rigid tire)*	kg	13 719	13 580	13 887	13 582	13 441	13 740	13 493	13 350	13 641
	lb	<b>30,238</b>	<b>29,930</b>	<b>30,608</b>	<b>29,935</b>	<b>29,624</b>	<b>30,284</b>	<b>29,739</b>	<b>29,425</b>	<b>30,065</b>
Static tipping load, articulated (ISO)*	kg	11 230	11 092	11 372	11 094	10 955	11 228	11 008	10 867	11 132
	lb	<b>24,752</b>	<b>24,447</b>	<b>25,064</b>	<b>24,453</b>	<b>24,145</b>	<b>24,747</b>	<b>24,261</b>	<b>23,951</b>	<b>24,536</b>
Static tipping load, articulated (rigid tire)*	kg	11 990	11 850	12 138	11 857	11 716	11 997	11 774	11 632	11 904
	lb	<b>26,427</b>	<b>26,119</b>	<b>26,754</b>	<b>26,134</b>	<b>25,823</b>	<b>26,442</b>	<b>25,951</b>	<b>25,637</b>	<b>26,237</b>
Breakout force** (§)	kN	180	178	197	169	167	184	161	159	175
	lbf	<b>40,442</b>	<b>40,157</b>	<b>44,336</b>	<b>37,997</b>	<b>37,715</b>	<b>41,441</b>	<b>36,203</b>	<b>35,922</b>	<b>39,334</b>
Operating weight*	kg	19 303	19 411	19 254	19 388	19 496	19 339	19 425	19 533	19 376
	lb	<b>42,544</b>	<b>42,782</b>	<b>42,436</b>	<b>42,730</b>	<b>42,968</b>	<b>42,622</b>	<b>42,811</b>	<b>43,049</b>	<b>42,703</b>

\*Static tipping loads and operating weights shown are based on a global machine configuration with Michelin 23.5R25 XHA2 L3 Radial tires, full fluids, operator, standard counterweight, standard linkage, cold start, roading fenders, Product Link, open differential axles (front/rear), power train guard, secondary steering, and sound suppression.

\*\*Measured 102 mm (4") behind tip of cutting edge with bucket hinge pin as pivot point in accordance with SAE J732C.

(§) Specifications and ratings conform to all applicable standards recommended by the Society of Automotive Engineers, including SAE Standard J732C governing loader ratings.

(ISO) Full compliance to ISO 14397-1 (2007) Sections 1 thru 6, which requires 2% verification between calculations and testing.

(Rigid Tire) Compliance to ISO 14397-1 (2007) Sections 1 thru 5.

**NOTE:** Bucket availability varies by region. Consult your local dealer for availability.

# Wheel Loaders Integrated Toolcarriers

## Performance Data ● 950K

Bucket Type		General Purpose — Pin On									
		Bolt-on Cutting Edges	Teeth & Segments	Teeth	Bolt-on Cutting Edges	Teeth & Segments	Teeth	Bolt-on Cutting Edges	Teeth & Segments	Teeth	
Edge Type											
	Capacity — rated (§)	m <sup>3</sup>	3.30	3.30	3.10	3.40	3.40	3.20	3.60	3.60	3.40
		yd <sup>3</sup>	<b>4.32</b>	<b>4.32</b>	<b>4.05</b>	<b>4.45</b>	<b>4.45</b>	<b>4.19</b>	<b>4.71</b>	<b>4.71</b>	<b>4.45</b>
Capacity — struck (§)		m <sup>3</sup>	2.94	2.94	2.72	3.04	3.04	2.81	3.18	3.18	2.94
		yd <sup>3</sup>	<b>3.85</b>	<b>3.85</b>	<b>3.56</b>	<b>3.98</b>	<b>3.98</b>	<b>3.68</b>	<b>4.16</b>	<b>4.16</b>	<b>3.85</b>
Width (§)		mm	2927	2994	2994	2927	2994	2994	2927	2994	2994
		ft/in	<b>9'7"</b>	<b>9'9"</b>	<b>9'9"</b>	<b>9'7"</b>	<b>9'9"</b>	<b>9'9"</b>	<b>9'7"</b>	<b>9'9"</b>	<b>9'9"</b>
Dump clearance at maximum lift and 45° discharge (§)		mm	2838	2719	2719	2819	2700	2700	2793	2673	2673
		ft/in	<b>9'3"</b>	<b>8'11"</b>	<b>8'11"</b>	<b>9'3"</b>	<b>8'10"</b>	<b>8'10"</b>	<b>9'1"</b>	<b>8'9"</b>	<b>8'9"</b>
Reach at maximum lift and 45° discharge (§)		mm	1458	1568	1568	1473	1582	1582	1495	1604	1604
		ft/in	<b>4'9"</b>	<b>5'1"</b>	<b>5'1"</b>	<b>4'10"</b>	<b>5'2"</b>	<b>5'2"</b>	<b>4'10"</b>	<b>5'3"</b>	<b>5'3"</b>
Reach at level lift arm and bucket level (§)		mm	2737	2898	2898	2761	2922	2922	2796	2957	2957
		ft/in	<b>8'11"</b>	<b>9'6"</b>	<b>9'6"</b>	<b>9'0"</b>	<b>9'7"</b>	<b>9'7"</b>	<b>9'2"</b>	<b>9'8"</b>	<b>9'8"</b>
Digging depth (§)		mm	90	90	60	90	90	60	90	90	60
		in	<b>3.5</b>	<b>3.5</b>	<b>2.3</b>	<b>3.5</b>	<b>3.5</b>	<b>2.3</b>	<b>3.5</b>	<b>3.5</b>	<b>2.3</b>
Overall length		mm	8211	8384	8384	8235	8408	8408	8270	8443	8443
		ft/in	<b>27'0"</b>	<b>27'7"</b>	<b>27'7"</b>	<b>27'1"</b>	<b>27'8"</b>	<b>27'8"</b>	<b>27'2"</b>	<b>27'9"</b>	<b>27'9"</b>
Overall height with bucket at maximum lift		mm	5571	5571	5571	5597	5597	5597	5630	5630	5630
		ft/in	<b>18'4"</b>	<b>18'4"</b>	<b>18'4"</b>	<b>18'5"</b>	<b>18'5"</b>	<b>18'5"</b>	<b>18'6"</b>	<b>18'6"</b>	<b>18'6"</b>
Loader clearance circle with bucket at carry position (§)		mm	13 791	13 961	13 961	13 805	13 975	13 975	13 826	13 997	13 997
		ft/in	<b>45'3"</b>	<b>45'10"</b>	<b>45'10"</b>	<b>45'4"</b>	<b>45'11"</b>	<b>45'11"</b>	<b>45'5"</b>	<b>46'0"</b>	<b>46'0"</b>
Static tipping load, straight (ISO)*		kg	12 620	12 478	12 759	12 577	12 434	12 712	12 506	12 363	12 638
		lb	<b>27,815</b>	<b>27,503</b>	<b>28,122</b>	<b>27,719</b>	<b>27,406</b>	<b>28,019</b>	<b>27,564</b>	<b>27,249</b>	<b>27,854</b>
Static tipping load, straight (rigid tire)*		kg	13 374	13 231	13 519	13 332	13 188	13 473	13 263	13 118	13 400
		lb	<b>29,477</b>	<b>29,161</b>	<b>29,797</b>	<b>29,384</b>	<b>29,067</b>	<b>29,696</b>	<b>29,232</b>	<b>28,914</b>	<b>29,534</b>
Static tipping load, articulated (ISO)*		kg	10 892	10 750	11 014	10 850	10 708	10 969	10 783	10 640	10 898
		lb	<b>24,006</b>	<b>23,694</b>	<b>24,275</b>	<b>23,915</b>	<b>23,601</b>	<b>24,176</b>	<b>23,767</b>	<b>23,452</b>	<b>24,020</b>
Static tipping load, articulated (rigid tire)*		kg	11 660	11 517	11 788	11 620	11 476	11 743	11 554	11 410	11 674
		lb	<b>25,700</b>	<b>25,384</b>	<b>25,980</b>	<b>25,611</b>	<b>25,294</b>	<b>25,883</b>	<b>25,467</b>	<b>25,148</b>	<b>25,729</b>
Breakout force** (§)		kN	154	153	167	151	150	164	147	146	159
		lbf	<b>34,742</b>	<b>34,463</b>	<b>37,633</b>	<b>34,071</b>	<b>33,792</b>	<b>36,855</b>	<b>33,133</b>	<b>32,855</b>	<b>35,772</b>
Operating weight*		kg	19 494	19 602	19 445	19 518	19 626	19 469	19 554	19 662	19 505
		lb	<b>42,964</b>	<b>43,202</b>	<b>42,856</b>	<b>43,017</b>	<b>43,255</b>	<b>42,909</b>	<b>43,097</b>	<b>43,335</b>	<b>42,989</b>

\*Static tipping loads and operating weights shown are based on a global machine configuration with Michelin 23.5R25 XHA2 L3 Radial tires, full fluids, operator, standard counterweight, standard linkage, cold start, roading fenders, Product Link, open differential axles (front/rear), power train guard, secondary steering, and sound suppression.

\*\*Measured 102 mm (4") behind tip of cutting edge with bucket hinge pin as pivot point in accordance with SAE J732C.

(§) Specifications and ratings conform to all applicable standards recommended by the Society of Automotive Engineers, including SAE Standard J732C governing loader ratings.

(ISO) Full compliance to ISO 14397-1 (2007) Sections 1 thru 6, which requires 2% verification between calculations and testing.

(Rigid Tire) Compliance to ISO 14397-1 (2007) Sections 1 thru 5.

**NOTE:** Bucket availability varies by region. Consult your local dealer for availability.

Bucket Type	General Purpose — Pin On			Material Handling — Pin On					
	Bolt-on Cutting Edges	Teeth & Segments	Teeth	Bolt-on Cutting Edges	Teeth & Segments	Teeth	Bolt-on Cutting Edges	Teeth & Segments	Teeth
Edge Type									
Capacity — rated (§)	m <sup>3</sup>	3.80	3.60	2.70	2.70	2.50	2.90	2.90	2.70
	yd <sup>3</sup>	<b>4.97</b>	<b>4.71</b>	<b>3.53</b>	<b>3.53</b>	<b>3.27</b>	<b>3.79</b>	<b>3.79</b>	<b>3.53</b>
Capacity — struck (§)	m <sup>3</sup>	3.36	3.12	2.32	2.32	2.11	2.52	2.52	2.31
	yd <sup>3</sup>	<b>4.39</b>	<b>4.08</b>	<b>3.03</b>	<b>3.03</b>	<b>2.76</b>	<b>3.30</b>	<b>3.30</b>	<b>3.02</b>
Width (§)	mm	2927	2994	2994	2927	2994	2994	2927	2994
	ft/in	<b>9'7"</b>	<b>9'9"</b>	<b>9'9"</b>	<b>9'7"</b>	<b>9'9"</b>	<b>9'9"</b>	<b>9'7"</b>	<b>9'9"</b>
Dump clearance at maximum lift and 45° discharge (§)	mm	2758	2638	2638	2896	2770	2770	2853	2728
	ft/in	<b>9'0"</b>	<b>8'7"</b>	<b>8'7"</b>	<b>9'6"</b>	<b>9'1"</b>	<b>9'1"</b>	<b>9'4"</b>	<b>8'11"</b>
Reach at maximum lift and 45° discharge (§)	mm	1524	1632	1632	1272	1374	1374	1314	1416
	ft/in	<b>5'0"</b>	<b>5'4"</b>	<b>5'4"</b>	<b>4'2"</b>	<b>4'6"</b>	<b>4'6"</b>	<b>4'3"</b>	<b>4'7"</b>
Reach at level lift arm and bucket level (§)	mm	2842	3003	3003	2581	2742	2742	2641	2802
	ft/in	<b>9'3"</b>	<b>9'10"</b>	<b>9'10"</b>	<b>8'5"</b>	<b>8'11"</b>	<b>8'11"</b>	<b>8'8"</b>	<b>9'2"</b>
Digging depth (§)	mm	90	90	60	90	90	60	90	60
	in	<b>3.5</b>	<b>3.5</b>	<b>2.3</b>	<b>3.5</b>	<b>3.5</b>	<b>2.3</b>	<b>3.5</b>	<b>2.3</b>
Overall length	mm	8316	8489	8489	8055	8228	8228	8115	8288
	ft/in	<b>27'4"</b>	<b>27'11"</b>	<b>27'11"</b>	<b>26'6"</b>	<b>27'0"</b>	<b>27'0"</b>	<b>26'8"</b>	<b>27'3"</b>
Overall height with bucket at maximum lift	mm	5678	5678	5678	5618	5618	5618	4975	4975
	ft/in	<b>18'8"</b>	<b>18'8"</b>	<b>18'8"</b>	<b>18'6"</b>	<b>18'6"</b>	<b>18'6"</b>	<b>16'4"</b>	<b>16'4"</b>
Loader clearance circle with bucket at carry position (§)	mm	13 854	14 025	14 025	13 700	13 868	13 868	13 734	13 903
	ft/in	<b>45'6"</b>	<b>46'1"</b>	<b>46'1"</b>	<b>45'0"</b>	<b>45'6"</b>	<b>45'6"</b>	<b>45'1"</b>	<b>45'8"</b>
Static tipping load, straight (ISO)*	kg	12 407	12 263	12 533	12 803	12 666	12 994	12 688	12 833
	lb	<b>27,345</b>	<b>27,028</b>	<b>27,623</b>	<b>28,219</b>	<b>27,916</b>	<b>28,639</b>	<b>27,965</b>	<b>28,285</b>
Static tipping load, straight (rigid tire)*	kg	13 165	13 020	13 297	13 531	13 392	13 730	13 419	13 569
	lb	<b>29,017</b>	<b>28,697</b>	<b>29,307</b>	<b>29,823</b>	<b>29,517</b>	<b>30,263</b>	<b>29,575</b>	<b>29,906</b>
Static tipping load, articulated (ISO)*	kg	10 688	10 545	10 798	11 078	10 941	11 252	10 969	11 098
	lb	<b>23,558</b>	<b>23,241</b>	<b>23,799</b>	<b>24,417</b>	<b>24,115</b>	<b>24,799</b>	<b>24,177</b>	<b>24,460</b>
Static tipping load, articulated (rigid tire)*	kg	11 461	11 316	11 575	11 821	11 683	12 003	11 715	11 848
	lb	<b>25,261</b>	<b>24,941</b>	<b>25,512</b>	<b>26,054</b>	<b>25,749</b>	<b>26,456</b>	<b>25,820</b>	<b>26,113</b>
Breakout force** (§)	kN	142	141	153	176	175	193	167	182
	lbf	<b>31,963</b>	<b>31,687</b>	<b>34,427</b>	<b>39,722</b>	<b>39,437</b>	<b>43,481</b>	<b>37,667</b>	<b>41,052</b>
Operating weight*	kg	19 609	19 717	19 560	19 326	19 434	19 277	19 382	19 333
	lb	<b>43,218</b>	<b>43,456</b>	<b>43,110</b>	<b>42,593</b>	<b>42,831</b>	<b>42,485</b>	<b>42,717</b>	<b>42,955</b>

\*Static tipping loads and operating weights shown are based on a global machine configuration with Michelin 23.5R25 XHA2 L3 Radial tires, full fluids, operator, standard counterweight, standard linkage, cold start, roading fenders, Product Link, open differential axles (front/rear), power train guard, secondary steering, and sound suppression.

\*\*Measured 102 mm (4") behind tip of cutting edge with bucket hinge pin as pivot point in accordance with SAE J732C.

(§) Specifications and ratings conform to all applicable standards recommended by the Society of Automotive Engineers, including SAE Standard J732C governing loader ratings.

(ISO) Full compliance to ISO 14397-1 (2007) Sections 1 thru 6, which requires 2% verification between calculations and testing.

(Rigid Tire) Compliance to ISO 14397-1 (2007) Sections 1 thru 5.

**NOTE:** Bucket availability varies by region. Consult your local dealer for availability.

Bucket Type	Material Handling – Pin On									
		Bolt-on Cutting Edges	Teeth & Segments	Teeth	Bolt-on Cutting Edges	Teeth & Segments	Teeth	Bolt-on Cutting Edges	Teeth & Segments	Teeth
Edge Type										
Capacity – rated (§)	m <sup>3</sup>	3.10	3.10	2.90	3.30	3.30	3.10	3.40	3.40	3.20
	yd <sup>3</sup>	<b>4.05</b>	<b>4.05</b>	<b>3.79</b>	<b>4.32</b>	<b>4.32</b>	<b>4.05</b>	<b>4.45</b>	<b>4.45</b>	<b>4.19</b>
Capacity – struck (§)	m <sup>3</sup>	2.61	2.61	2.44	2.78	2.78	2.61	2.92	2.92	2.74
	yd <sup>3</sup>	<b>3.41</b>	<b>3.41</b>	<b>3.19</b>	<b>3.64</b>	<b>3.64</b>	<b>3.41</b>	<b>3.82</b>	<b>3.82</b>	<b>3.58</b>
Width (§)	mm	2927	2994	2994	2927	2994	2994	2927	2994	2994
	ft/in	<b>9'7"</b>	<b>9'9"</b>	<b>9'9"</b>	<b>9'7"</b>	<b>9'9"</b>	<b>9'9"</b>	<b>9'7"</b>	<b>9'9"</b>	<b>9'9"</b>
Dump clearance at maximum lift and 45° discharge (§)	mm	2821	2696	2696	2789	2664	2664	2761	2636	2636
	ft/in	<b>9'3"</b>	<b>8'10"</b>	<b>8'10"</b>	<b>9'1"</b>	<b>8'8"</b>	<b>8'8"</b>	<b>9'0"</b>	<b>8'7"</b>	<b>8'7"</b>
Reach at maximum lift and 45° discharge (§)	mm	1346	1448	1448	1378	1480	1480	1406	1508	1508
	ft/in	<b>4'5"</b>	<b>4'9"</b>	<b>4'9"</b>	<b>4'6"</b>	<b>4'10"</b>	<b>4'10"</b>	<b>4'7"</b>	<b>4'11"</b>	<b>4'11"</b>
Reach at level lift arm and bucket level (§)	mm	2686	2847	2847	2731	2892	2892	2771	2932	2932
	ft/in	<b>8'9"</b>	<b>9'4"</b>	<b>9'4"</b>	<b>8'11"</b>	<b>9'5"</b>	<b>9'5"</b>	<b>9'1"</b>	<b>9'7"</b>	<b>9'7"</b>
Digging depth (§)	mm	90	90	60	90	90	60	90	90	60
	in	<b>3.5</b>	<b>3.5</b>	<b>2.3</b>	<b>3.5</b>	<b>3.5</b>	<b>2.3</b>	<b>3.5</b>	<b>3.5</b>	<b>2.3</b>
Overall length	mm	8160	8333	8333	8205	8378	8378	8245	8418	8418
	ft/in	<b>26'10"</b>	<b>27'5"</b>	<b>27'5"</b>	<b>27'0"</b>	<b>27'6"</b>	<b>27'6"</b>	<b>27'1"</b>	<b>27'8"</b>	<b>27'8"</b>
Overall height with bucket at maximum lift	mm	5483	5483	5483	5527	5527	5527	5566	5566	5566
	ft/in	<b>18'0"</b>	<b>18'0"</b>	<b>18'0"</b>	<b>18'2"</b>	<b>18'2"</b>	<b>18'2"</b>	<b>18'4"</b>	<b>18'4"</b>	<b>18'4"</b>
Loader clearance circle with bucket at carry position (§)	mm	13 761	13 930	13 930	13 787	13 957	13 957	13 811	13 981	13 981
	ft/in	<b>45'2"</b>	<b>45'9"</b>	<b>45'9"</b>	<b>45'3"</b>	<b>45'10"</b>	<b>45'10"</b>	<b>45'4"</b>	<b>45'11"</b>	<b>45'11"</b>
Static tipping load, straight (ISO)*	kg	12 595	12 456	12 734	12 504	12 364	12 638	12 426	12 285	12 556
	lb	<b>27,760</b>	<b>27,453</b>	<b>28,066</b>	<b>27,560</b>	<b>27,251</b>	<b>27,855</b>	<b>27,387</b>	<b>27,076</b>	<b>27,673</b>
Static tipping load, straight (rigid tire)*	kg	13 328	13 187	13 471	13 239	13 097	13 377	13 162	13 019	13 296
	lb	<b>29,375</b>	<b>29,065</b>	<b>29,691</b>	<b>29,178</b>	<b>28,866</b>	<b>29,484</b>	<b>29,009</b>	<b>28,695</b>	<b>29,305</b>
Static tipping load, articulated (ISO)*	kg	10 881	10 741	11 003	10 794	10 654	10 912	10 719	10 579	10 833
	lb	<b>23,982</b>	<b>23,675</b>	<b>24,251</b>	<b>23,791</b>	<b>23,482</b>	<b>24,050</b>	<b>23,626</b>	<b>23,316</b>	<b>23,877</b>
Static tipping load, articulated (rigid tire)*	kg	11 628	11 487	11 755	11 543	11 402	11 665	11 470	11 328	11 588
	lb	<b>25,629</b>	<b>25,319</b>	<b>25,908</b>	<b>25,442</b>	<b>25,130</b>	<b>25,711</b>	<b>25,282</b>	<b>24,968</b>	<b>25,541</b>
Breakout force** (§)	kN	161	160	175	155	154	168	150	149	162
	lbf	<b>36,235</b>	<b>35,954</b>	<b>39,374</b>	<b>34,901</b>	<b>34,621</b>	<b>37,819</b>	<b>33,788</b>	<b>33,510</b>	<b>36,529</b>
Operating weight*	kg	19 432	19 540	19 383	19 480	19 588	19 431	19 520	19 628	19 471
	lb	<b>42,827</b>	<b>43,065</b>	<b>42,719</b>	<b>42,933</b>	<b>43,171</b>	<b>42,825</b>	<b>43,021</b>	<b>43,259</b>	<b>42,913</b>

\*Static tipping loads and operating weights shown are based on a global machine configuration with Michelin 23.5R25 XHA2 L3 Radial tires, full fluids, operator, standard counterweight, standard linkage, cold start, roading fenders, Product Link, open differential axles (front/rear), power train guard, secondary steering, and sound suppression.

\*\*Measured 102 mm (4") behind tip of cutting edge with bucket hinge pin as pivot point in accordance with SAE J732C.

(§) Specifications and ratings conform to all applicable standards recommended by the Society of Automotive Engineers, including SAE Standard J732C governing loader ratings.

(ISO) Full compliance to ISO 14397-1 (2007) Sections 1 thru 6, which requires 2% verification between calculations and testing.

(Rigid Tire) Compliance to ISO 14397-1 (2007) Sections 1 thru 5.

**NOTE:** Bucket availability varies by region. Consult your local dealer for availability.

Bucket Type	Material Handling — Pin On						General Purpose — Fusion QC			
	Bolt-on Cutting Edges	Teeth & Segments	Teeth	Bolt-on Cutting Edges	Teeth & Segments	Teeth	Bolt-on Cutting Edges	Teeth & Segments	Teeth	
Edge Type										
	Capacity — rated (§)	m <sup>3</sup>	3.60	3.40	3.80	3.80	3.60	2.70	2.70	2.50
		yd <sup>3</sup>	<b>4.71</b>	<b>4.71</b>	<b>4.45</b>	<b>4.97</b>	<b>4.97</b>	<b>4.71</b>	<b>3.53</b>	<b>3.27</b>
Capacity — struck (§)	m <sup>3</sup>	3.15	3.15	2.95	3.28	3.28	3.11	2.30	2.30	2.11
	yd <sup>3</sup>	<b>4.12</b>	<b>4.12</b>	<b>3.86</b>	<b>4.29</b>	<b>4.29</b>	<b>4.07</b>	<b>3.01</b>	<b>3.01</b>	<b>2.76</b>
Width (§)	mm	2927	2994	2994	2927	2994	2994	2927	2994	2994
	ft/in	<b>9'7"</b>	<b>9'9"</b>	<b>9'9"</b>	<b>9'7"</b>	<b>9'9"</b>	<b>9'9"</b>	<b>9'7"</b>	<b>9'9"</b>	<b>9'9"</b>
Dump clearance at maximum lift and 45° discharge (§)	mm	2729	2604	2604	2693	2568	2568	2936	2820	2820
	ft/in	<b>8'11"</b>	<b>8'6"</b>	<b>8'6"</b>	<b>8'10"</b>	<b>8'5"</b>	<b>8'5"</b>	<b>9'7"</b>	<b>9'3"</b>	<b>9'3"</b>
Reach at maximum lift and 45° discharge (§)	mm	1438	1540	1540	1474	1576	1576	1402	1516	1516
	ft/in	<b>4'8"</b>	<b>5'0"</b>	<b>5'0"</b>	<b>4'10"</b>	<b>5'2"</b>	<b>5'2"</b>	<b>4'7"</b>	<b>4'11"</b>	<b>4'11"</b>
Reach at level lift arm and bucket level (§)	mm	2816	2977	2977	2867	3028	3028	2622	2783	2783
	ft/in	<b>9'2"</b>	<b>9'9"</b>	<b>9'9"</b>	<b>9'4"</b>	<b>9'11"</b>	<b>9'11"</b>	<b>8'7"</b>	<b>9'1"</b>	<b>9'1"</b>
Digging depth (§)	mm	90	90	60	90	90	60	90	90	60
	in	<b>3.5</b>	<b>3.5</b>	<b>2.3</b>	<b>3.5</b>	<b>3.5</b>	<b>2.3</b>	<b>3.5</b>	<b>3.5</b>	<b>2.3</b>
Overall length	mm	8290	8463	8463	8341	8514	8514	8096	8269	8269
	ft/in	<b>27'3"</b>	<b>27'10"</b>	<b>27'10"</b>	<b>27'5"</b>	<b>28'0"</b>	<b>28'0"</b>	<b>26'7"</b>	<b>27'2"</b>	<b>27'2"</b>
Overall height with bucket at maximum lift	mm	5614	5614	5614	5662	5662	5662	5424	5424	5424
	ft/in	<b>18'6"</b>	<b>18'6"</b>	<b>18'6"</b>	<b>18'7"</b>	<b>18'7"</b>	<b>18'7"</b>	<b>17'10"</b>	<b>17'10"</b>	<b>17'10"</b>
Loader clearance circle with bucket at carry position (§)	mm	13 838	14 009	14 009	13 869	14 041	14 041	13 714	13 884	13 884
	ft/in	<b>45'5"</b>	<b>46'0"</b>	<b>46'0"</b>	<b>45'6"</b>	<b>46'1"</b>	<b>46'1"</b>	<b>45'0"</b>	<b>45'7"</b>	<b>45'7"</b>
Static tipping load, straight (ISO)*	kg	12 338	12 196	12 463	12 236	12 093	12 356	12 379	12 241	12 575
	lb	<b>27,194</b>	<b>26,882</b>	<b>27,470</b>	<b>26,969</b>	<b>26,654</b>	<b>27,234</b>	<b>27,283</b>	<b>26,979</b>	<b>27,715</b>
Static tipping load, straight (rigid tire)*	kg	13 076	12 933	13 205	12 976	12 832	13 100	13 113	12 974	13 321
	lb	<b>28,820</b>	<b>28,504</b>	<b>29,105</b>	<b>28,599</b>	<b>28,281</b>	<b>28,873</b>	<b>28,903</b>	<b>28,596</b>	<b>29,360</b>
Static tipping load, articulated (ISO)*	kg	10 636	10 495	10 746	10 539	10 396	10 643	10 661	10 523	10 839
	lb	<b>23,443</b>	<b>23,131</b>	<b>23,684</b>	<b>23,228</b>	<b>22,914</b>	<b>23,459</b>	<b>23,497</b>	<b>23,194</b>	<b>23,889</b>
Static tipping load, articulated (rigid tire)*	kg	11 389	11 246	11 502	11 294	11 150	11 402	11 411	11 271	11 599
	lb	<b>25,102</b>	<b>24,787</b>	<b>25,351</b>	<b>24,892</b>	<b>24,574</b>	<b>25,130</b>	<b>25,150</b>	<b>24,843</b>	<b>25,565</b>
Breakout force** (§)	kN	145	143	156	139	138	150	170	169	186
	lbf	<b>32,610</b>	<b>32,333</b>	<b>35,171</b>	<b>31,355</b>	<b>31,079</b>	<b>33,731</b>	<b>38,308</b>	<b>38,025</b>	<b>41,807</b>
Operating weight*	kg	19 564	19 672	19 515	19 618	19 726	19 569	19 778	19 886	19 729
	lb	<b>43,118</b>	<b>43,356</b>	<b>43,010</b>	<b>43,237</b>	<b>43,475</b>	<b>43,129</b>	<b>43,589</b>	<b>43,827</b>	<b>43,481</b>

\*Static tipping loads and operating weights shown are based on a global machine configuration with Michelin 23.5R25 XHA2 L3 Radial tires, full fluids, operator, standard counterweight, standard linkage, cold start, roading fenders, Product Link, open differential axles (front/rear), power train guard, secondary steering, and sound suppression.

\*\*Measured 102 mm (4") behind tip of cutting edge with bucket hinge pin as pivot point in accordance with SAE J732C.

(§) Specifications and ratings conform to all applicable standards recommended by the Society of Automotive Engineers, including SAE Standard J732C governing loader ratings.

(ISO) Full compliance to ISO 14397-1 (2007) Sections 1 thru 6, which requires 2% verification between calculations and testing.

(Rigid Tire) Compliance to ISO 14397-1 (2007) Sections 1 thru 5.

**NOTE:** Bucket availability varies by region. Consult your local dealer for availability.



# Wheel Loaders Integrated Toolcarriers

## Performance Data ● 950K

Bucket Type		General Purpose — Fusion QC									
		Bolt-on Cutting Edges	Teeth & Segments	Teeth	Bolt-on Cutting Edges	Teeth & Segments	Teeth	Bolt-on Cutting Edges	Teeth & Segments	Teeth	
Edge Type											
	Capacity — rated (§)	m <sup>3</sup>	2.90	2.90	2.70	3.10	3.10	2.90	3.30	3.30	3.10
		yd <sup>3</sup>	<b>3.79</b>	<b>3.79</b>	<b>3.53</b>	<b>4.05</b>	<b>4.05</b>	<b>3.79</b>	<b>4.32</b>	<b>4.32</b>	<b>4.05</b>
Capacity — struck (§)		m <sup>3</sup>	2.55	2.55	2.33	2.76	2.76	2.54	2.94	2.94	2.72
		yd <sup>3</sup>	<b>3.34</b>	<b>3.34</b>	<b>3.05</b>	<b>3.61</b>	<b>3.61</b>	<b>3.32</b>	<b>3.85</b>	<b>3.85</b>	<b>3.56</b>
Width (§)		mm	2927	2994	2994	2927	2994	2994	2927	2994	2994
		ft/in	<b>9'7"</b>	<b>9'9"</b>	<b>9'9"</b>	<b>9'7"</b>	<b>9'9"</b>	<b>9'9"</b>	<b>9'7"</b>	<b>9'9"</b>	<b>9'9"</b>
Dump clearance at maximum lift and 45° discharge (§)		mm	2880	2763	2763	2837	2718	2718	2798	2679	2679
		ft/in	<b>9'5"</b>	<b>9'0"</b>	<b>9'0"</b>	<b>9'3"</b>	<b>8'11"</b>	<b>8'11"</b>	<b>9'2"</b>	<b>8'9"</b>	<b>8'9"</b>
Reach at maximum lift and 45° discharge (§)		mm	1440	1552	1552	1475	1585	1585	1503	1613	1613
		ft/in	<b>4'8"</b>	<b>5'1"</b>	<b>5'1"</b>	<b>4'10"</b>	<b>5'2"</b>	<b>5'2"</b>	<b>4'11"</b>	<b>5'3"</b>	<b>5'3"</b>
Reach at level lift arm and bucket level (§)		mm	2691	2852	2852	2748	2909	2909	2797	2958	2958
		ft/in	<b>8'9"</b>	<b>9'4"</b>	<b>9'4"</b>	<b>9'0"</b>	<b>9'6"</b>	<b>9'6"</b>	<b>9'2"</b>	<b>9'8"</b>	<b>9'8"</b>
Digging depth (§)		mm	90	90	60	90	90	60	90	90	60
		in	<b>3.5</b>	<b>3.5</b>	<b>2.3</b>	<b>3.5</b>	<b>3.5</b>	<b>2.3</b>	<b>3.5</b>	<b>3.5</b>	<b>2.3</b>
Overall length		mm	8165	8338	8338	8222	8395	8395	8271	8444	8444
		ft/in	<b>26'10"</b>	<b>27'5"</b>	<b>27'5"</b>	<b>27'0"</b>	<b>27'7"</b>	<b>27'7"</b>	<b>27'2"</b>	<b>27'9"</b>	<b>27'9"</b>
Overall height with bucket at maximum lift		mm	5497	5497	5497	5558	5558	5558	5604	5604	5604
		ft/in	<b>18'1"</b>	<b>18'1"</b>	<b>18'1"</b>	<b>18'3"</b>	<b>18'3"</b>	<b>18'3"</b>	<b>18'5"</b>	<b>18'5"</b>	<b>18'5"</b>
Loader clearance circle with bucket at carry position (§)		mm	13 755	13 926	13 926	13 789	13 961	13 961	13 818	13 991	13 991
		ft/in	<b>45'2"</b>	<b>45'9"</b>	<b>45'9"</b>	<b>45'3"</b>	<b>45'10"</b>	<b>45'10"</b>	<b>45'5"</b>	<b>45'11"</b>	<b>45'11"</b>
Static tipping load, straight (ISO)*		kg	12 265	12 125	12 456	12 155	12 015	12 344	12 065	11 924	12 252
		lb	<b>27,032</b>	<b>26,725</b>	<b>27,454</b>	<b>26,790</b>	<b>26,481</b>	<b>27,208</b>	<b>26,591</b>	<b>26,280</b>	<b>27,004</b>
Static tipping load, straight (rigid tire)*		kg	13 003	12 862	13 205	12 896	12 754	13 096	12 808	12 665	13 006
		lb	<b>28,659</b>	<b>28,349</b>	<b>29,105</b>	<b>28,423</b>	<b>28,111</b>	<b>28,865</b>	<b>28,230</b>	<b>27,915</b>	<b>28,666</b>
Static tipping load, articulated (ISO)*		kg	10 552	10 413	10 726	10 448	10 308	10 620	10 363	10 221	10 532
		lb	<b>23,257</b>	<b>22,950</b>	<b>23,640</b>	<b>23,029</b>	<b>22,720</b>	<b>23,407</b>	<b>22,840</b>	<b>22,529</b>	<b>23,214</b>
Static tipping load, articulated (rigid tire)*		kg	11 305	11 164	11 489	11 204	11 062	11 386	11 120	10 978	11 301
		lb	<b>24,917</b>	<b>24,606</b>	<b>25,323</b>	<b>24,694</b>	<b>24,382</b>	<b>25,096</b>	<b>24,510</b>	<b>24,196</b>	<b>24,908</b>
Breakout force** (§)		kN	160	159	174	153	152	166	147	146	159
		lbf	<b>36,105</b>	<b>35,825</b>	<b>39,220</b>	<b>34,451</b>	<b>34,172</b>	<b>37,295</b>	<b>33,132</b>	<b>32,855</b>	<b>35,769</b>
Operating weight*		kg	19 840	19 948	19 791	19 894	20 002	19 845	19 941	20 049	19 892
		lb	<b>43,727</b>	<b>43,965</b>	<b>43,619</b>	<b>43,847</b>	<b>44,085</b>	<b>43,739</b>	<b>43,949</b>	<b>44,187</b>	<b>43,841</b>

\*Static tipping loads and operating weights shown are based on a global machine configuration with Michelin 23.5R25 XHA2 L3 Radial tires, full fluids, operator, standard counterweight, standard linkage, cold start, roading fenders, Product Link, open differential axles (front/rear), power train guard, secondary steering, and sound suppression.

\*\*Measured 102 mm (4") behind tip of cutting edge with bucket hinge pin as pivot point in accordance with SAE J732C.

(§) Specifications and ratings conform to all applicable standards recommended by the Society of Automotive Engineers, including SAE Standard J732C governing loader ratings.

(ISO) Full compliance to ISO 14397-1 (2007) Sections 1 thru 6, which requires 2% verification between calculations and testing.

(Rigid Tire) Compliance to ISO 14397-1 (2007) Sections 1 thru 5.

**NOTE:** Bucket availability varies by region. Consult your local dealer for availability.

Bucket Type		General Purpose — Fusion QC									
		Bolt-on Cutting Edges	Teeth & Segments	Teeth	Bolt-on Cutting Edges	Teeth & Segments	Teeth	Bolt-on Cutting Edges	Teeth & Segments	Teeth	
Edge Type											
	Capacity — rated (§)	m <sup>3</sup>	3.40	3.40	3.20	3.60	3.60	3.40	3.80	3.80	3.60
		yd <sup>3</sup>	<b>4.45</b>	<b>4.45</b>	<b>4.19</b>	<b>4.71</b>	<b>4.71</b>	<b>4.45</b>	<b>4.97</b>	<b>4.97</b>	<b>4.71</b>
Capacity — struck (§)		m <sup>3</sup>	3.04	3.04	2.81	3.18	3.18	2.94	3.36	3.36	3.12
		yd <sup>3</sup>	<b>3.98</b>	<b>3.98</b>	<b>3.68</b>	<b>4.16</b>	<b>4.16</b>	<b>3.85</b>	<b>4.39</b>	<b>4.39</b>	<b>4.08</b>
Width (§)		mm	2927	2994	2994	2927	2994	2994	2927	2994	2994
		ft/in	<b>9'7"</b>	<b>9'9"</b>	<b>9'9"</b>	<b>9'7"</b>	<b>9'9"</b>	<b>9'9"</b>	<b>9'7"</b>	<b>9'9"</b>	<b>9'9"</b>
Dump clearance at maximum lift and 45° discharge (§)		mm	2779	2660	2660	2753	2633	2633	2718	2598	2598
		ft/in	<b>9'1"</b>	<b>8'8"</b>	<b>8'8"</b>	<b>9'0"</b>	<b>8'7"</b>	<b>8'7"</b>	<b>8'11"</b>	<b>8'6"</b>	<b>8'6"</b>
Reach at maximum lift and 45° discharge (§)		mm	1518	1627	1627	1539	1648	1648	1568	1677	1677
		ft/in	<b>4'11"</b>	<b>5'4"</b>	<b>5'4"</b>	<b>5'0"</b>	<b>5'4"</b>	<b>5'4"</b>	<b>5'1"</b>	<b>5'6"</b>	<b>5'6"</b>
Reach at level lift arm and bucket level (§)		mm	2821	2982	2982	2856	3017	3017	2902	3063	3063
		ft/in	<b>9'3"</b>	<b>9'9"</b>	<b>9'9"</b>	<b>9'4"</b>	<b>9'10"</b>	<b>9'10"</b>	<b>9'6"</b>	<b>10'0"</b>	<b>10'0"</b>
Digging depth (§)		mm	90	90	60	90	90	60	90	90	60
		in	<b>3.5</b>	<b>3.5</b>	<b>2.3</b>	<b>3.5</b>	<b>3.5</b>	<b>2.3</b>	<b>3.5</b>	<b>3.5</b>	<b>2.3</b>
Overall length		mm	8295	8468	8468	8330	8503	8503	8376	8549	8549
		ft/in	<b>27'3"</b>	<b>27'10"</b>	<b>27'10"</b>	<b>27'4"</b>	<b>27'11"</b>	<b>27'11"</b>	<b>27'6"</b>	<b>28'1"</b>	<b>28'1"</b>
Overall height with bucket at maximum lift		mm	5630	5630	5630	5664	5664	5664	5711	5711	5711
		ft/in	<b>18'6"</b>	<b>18'6"</b>	<b>18'6"</b>	<b>18'7"</b>	<b>18'7"</b>	<b>18'7"</b>	<b>18'9"</b>	<b>18'9"</b>	<b>18'9"</b>
Loader clearance circle with bucket at carry position (§)		mm	13 833	14 006	14 006	13 854	14 028	14 028	13 883	14 057	14 057
		ft/in	<b>45'5"</b>	<b>46'0"</b>	<b>46'0"</b>	<b>45'6"</b>	<b>46'1"</b>	<b>46'1"</b>	<b>45'7"</b>	<b>46'2"</b>	<b>46'2"</b>
Static tipping load, straight (ISO)*		kg	12 023	11 881	12 209	11 957	11 815	12 142	11 871	11 728	12 054
		lb	<b>26,499</b>	<b>26,187</b>	<b>26,908</b>	<b>26,355</b>	<b>26,041</b>	<b>26,761</b>	<b>26,165</b>	<b>25,849</b>	<b>26,567</b>
Static tipping load, straight (rigid tire)*		kg	12 767	12 624	12 964	12 703	12 559	12 898	12 619	12 474	12 812
		lb	<b>28,139</b>	<b>27,823</b>	<b>28,572</b>	<b>27,998</b>	<b>27,681</b>	<b>28,428</b>	<b>27,813</b>	<b>27,494</b>	<b>28,239</b>
Static tipping load, articulated (ISO)*		kg	10 322	10 181	10 491	10 260	10 118	10 428	10 178	10 035	10 344
		lb	<b>22,751</b>	<b>22,439</b>	<b>23,123</b>	<b>22,614</b>	<b>22,301</b>	<b>22,983</b>	<b>22,434</b>	<b>22,118</b>	<b>22,799</b>
Static tipping load, articulated (rigid tire)*		kg	11 081	10 938	11 260	11 021	10 877	11 199	10 941	10 796	11 117
		lb	<b>24,424</b>	<b>24,108</b>	<b>24,818</b>	<b>24,290</b>	<b>23,973</b>	<b>24,682</b>	<b>24,114</b>	<b>23,795</b>	<b>24,502</b>
Breakout force** (§)		kN	144	143	156	140	139	151	136	134	146
		lbf	<b>32,517</b>	<b>32,240</b>	<b>35,060</b>	<b>31,655</b>	<b>31,379</b>	<b>34,072</b>	<b>30,581</b>	<b>30,306</b>	<b>32,844</b>
Operating weight*		kg	19 964	20 072	19 915	19 998	20 106	19 949	20 043	20 151	19 994
		lb	<b>44,001</b>	<b>44,239</b>	<b>43,893</b>	<b>44,076</b>	<b>44,314</b>	<b>43,968</b>	<b>44,175</b>	<b>44,413</b>	<b>44,067</b>

\*Static tipping loads and operating weights shown are based on a global machine configuration with Michelin 23.5R25 XHA2 L3 Radial tires, full fluids, operator, standard counterweight, standard linkage, cold start, roading fenders, Product Link, open differential axles (front/rear), power train guard, secondary steering, and sound suppression.

\*\*Measured 102 mm (4") behind tip of cutting edge with bucket hinge pin as pivot point in accordance with SAE J732C.

(§) Specifications and ratings conform to all applicable standards recommended by the Society of Automotive Engineers, including SAE Standard J732C governing loader ratings.

(ISO) Full compliance to ISO 14397-1 (2007) Sections 1 thru 6, which requires 2% verification between calculations and testing.

(Rigid Tire) Compliance to ISO 14397-1 (2007) Sections 1 thru 5.

**NOTE:** Bucket availability varies by region. Consult your local dealer for availability.

Bucket Type		Material Handling — Fusion QC								
		Bolt-on Cutting Edges	Teeth & Segments	Teeth	Bolt-on Cutting Edges	Teeth & Segments	Teeth	Bolt-on Cutting Edges	Teeth & Segments	Teeth
Edge Type										
	Capacity — rated (§)	m <sup>3</sup>	2.70	2.50	2.90	2.70	3.10	3.10	3.10	2.90
		yd <sup>3</sup>	<b>3.53</b>	<b>3.27</b>	<b>3.79</b>	<b>3.53</b>	<b>4.05</b>	<b>4.05</b>	<b>4.05</b>	<b>3.79</b>
Capacity — struck (§)		m <sup>3</sup>	2.20	2.00	2.40	2.20	2.61	2.61	2.61	2.44
		yd <sup>3</sup>	<b>2.88</b>	<b>2.62</b>	<b>3.14</b>	<b>2.88</b>	<b>3.41</b>	<b>3.41</b>	<b>3.41</b>	<b>3.19</b>
Width (§)		mm	2927	2994	2927	2994	2994	2927	2994	2994
		ft/in	<b>9'7"</b>	<b>9'9"</b>	<b>9'7"</b>	<b>9'9"</b>	<b>9'9"</b>	<b>9'7"</b>	<b>9'9"</b>	<b>9'9"</b>
Dump clearance at maximum lift and 45° discharge (§)		mm	2853	2728	2811	2685	2685	2779	2653	2653
		ft/in	<b>9'4"</b>	<b>8'11"</b>	<b>9'2"</b>	<b>8'9"</b>	<b>8'9"</b>	<b>9'1"</b>	<b>8'8"</b>	<b>8'8"</b>
Reach at maximum lift and 45° discharge (§)		mm	1314	1416	1357	1459	1459	1389	1491	1491
		ft/in	<b>4'3"</b>	<b>4'7"</b>	<b>4'5"</b>	<b>4'9"</b>	<b>4'9"</b>	<b>4'6"</b>	<b>4'10"</b>	<b>4'10"</b>
Reach at level lift arm and bucket level (§)		mm	2641	2802	2701	2862	2746	2907	2907	2907
		ft/in	<b>8'8"</b>	<b>9'2"</b>	<b>8'10"</b>	<b>9'4"</b>	<b>9'0"</b>	<b>9'6"</b>	<b>9'6"</b>	<b>9'6"</b>
Digging depth (§)		mm	90	90	90	90	90	90	90	90
		in	<b>3.5</b>	<b>3.5</b>	<b>2.3</b>	<b>3.5</b>	<b>3.5</b>	<b>2.3</b>	<b>3.5</b>	<b>2.3</b>
Overall length		mm	8115	8288	8175	8348	8220	8393	8393	8393
		ft/in	<b>26'8"</b>	<b>27'3"</b>	<b>26'10"</b>	<b>27'5"</b>	<b>27'0"</b>	<b>27'7"</b>	<b>27'7"</b>	<b>27'7"</b>
Overall height with bucket at maximum lift		mm	5418	5418	5480	5480	5517	5517	5517	5517
		ft/in	<b>17'10"</b>	<b>17'10"</b>	<b>18'0"</b>	<b>18'0"</b>	<b>18'0"</b>	<b>18'2"</b>	<b>18'2"</b>	<b>18'2"</b>
Loader clearance circle with bucket at carry position (§)		mm	13 725	13 895	13 761	13 932	13 932	13 788	13 959	13 959
		ft/in	<b>45'1"</b>	<b>45'8"</b>	<b>45'2"</b>	<b>45'9"</b>	<b>45'9"</b>	<b>45'3"</b>	<b>45'10"</b>	<b>45'10"</b>
Static tipping load, straight (ISO)*		kg	12 234	12 097	12 417	12 130	11 992	12 308	11 899	12 216
		lb	<b>26,965</b>	<b>26,663</b>	<b>27,367</b>	<b>26,734</b>	<b>26,430</b>	<b>27,127</b>	<b>26,533</b>	<b>26,227</b>
Static tipping load, straight (rigid tire)*		kg	12 953	12 815	13 144	12 851	12 711	13 038	12 621	12 947
		lb	<b>28,548</b>	<b>28,244</b>	<b>28,970</b>	<b>28,323</b>	<b>28,016</b>	<b>28,736</b>	<b>28,125</b>	<b>27,816</b>
Static tipping load, articulated (ISO)*		kg	10 535	10 398	10 701	10 436	10 298	10 598	10 349	10 510
		lb	<b>23,220</b>	<b>22,918</b>	<b>23,586</b>	<b>23,001</b>	<b>22,697</b>	<b>23,359</b>	<b>22,809</b>	<b>22,504</b>
Static tipping load, articulated (rigid tire)*		kg	11 269	11 131	11 444	11 172	11 033	11 343	10 947	11 257
		lb	<b>24,837</b>	<b>24,533</b>	<b>25,222</b>	<b>24,624</b>	<b>24,317</b>	<b>25,001</b>	<b>24,436</b>	<b>24,127</b>
Breakout force** (§)		kN	167	166	182	159	158	173	152	166
		lbf	<b>37,672</b>	<b>37,389</b>	<b>41,057</b>	<b>35,805</b>	<b>35,524</b>	<b>38,869</b>	<b>34,496</b>	<b>37,348</b>
Operating weight*		kg	19 784	19 892	19 735	19 836	19 944	19 787	19 885	19 836
		lb	<b>43,602</b>	<b>43,840</b>	<b>43,494</b>	<b>43,717</b>	<b>43,955</b>	<b>43,609</b>	<b>43,825</b>	<b>43,717</b>

\*Static tipping loads and operating weights shown are based on a global machine configuration with Michelin 23.5R25 XHA2 L3 Radial tires, full fluids, operator, standard counterweight, standard linkage, cold start, roading fenders, Product Link, open differential axles (front/rear), power train guard, secondary steering, and sound suppression.

\*\*Measured 102 mm (4") behind tip of cutting edge with bucket hinge pin as pivot point in accordance with SAE J732C.

(§) Specifications and ratings conform to all applicable standards recommended by the Society of Automotive Engineers, including SAE Standard J732C governing loader ratings.

(ISO) Full compliance to ISO 14397-1 (2007) Sections 1 thru 6, which requires 2% verification between calculations and testing.

(Rigid Tire) Compliance to ISO 14397-1 (2007) Sections 1 thru 5.

**NOTE:** Bucket availability varies by region. Consult your local dealer for availability.

Bucket Type	Material Handling — Fusion QC					
	Bolt-on Cutting Edges	Teeth & Segments	Teeth	Bolt-on Cutting Edges	Teeth & Segments	Teeth
Edge Type						
Capacity — rated (§)	m <sup>3</sup>	3.30	3.30	3.10	3.40	3.40
	yd <sup>3</sup>	<b>4.32</b>	<b>4.32</b>	<b>4.05</b>	<b>4.45</b>	<b>4.45</b>
Capacity — struck (§)	m <sup>3</sup>	2.78	2.78	2.61	2.92	2.92
	yd <sup>3</sup>	<b>3.64</b>	<b>3.64</b>	<b>3.41</b>	<b>3.82</b>	<b>3.82</b>
Width (§)	mm	2927	2994	2994	2927	2994
	ft/in	<b>9'7"</b>	<b>9'9"</b>	<b>9'9"</b>	<b>9'7"</b>	<b>9'9"</b>
Dump clearance at maximum lift and 45° discharge (§)	mm	2747	2622	2622	2719	2593
	ft/in	<b>9'0"</b>	<b>8'7"</b>	<b>8'7"</b>	<b>8'11"</b>	<b>8'6"</b>
Reach at maximum lift and 45° discharge (§)	mm	1420	1523	1523	1449	1551
	ft/in	<b>4'7"</b>	<b>4'11"</b>	<b>4'11"</b>	<b>4'9"</b>	<b>5'1"</b>
Reach at level lift arm and bucket level (§)	mm	2791	2952	2952	2831	2992
	ft/in	<b>9'1"</b>	<b>9'8"</b>	<b>9'8"</b>	<b>9'3"</b>	<b>9'9"</b>
Digging depth (§)	mm	90	90	60	90	90
	in	<b>3.5</b>	<b>3.5</b>	<b>2.3</b>	<b>3.5</b>	<b>3.5</b>
Overall length	mm	8265	8438	8438	8305	8478
	ft/in	<b>27'2"</b>	<b>27'9"</b>	<b>27'9"</b>	<b>27'3"</b>	<b>27'10"</b>
Overall height with bucket at maximum lift	mm	5561	5561	5561	5600	5600
	ft/in	<b>18'3"</b>	<b>18'3"</b>	<b>18'3"</b>	<b>18'5"</b>	<b>18'5"</b>
Loader clearance circle with bucket at carry position (§)	mm	13 815	13 987	13 987	13 839	14 012
	ft/in	<b>45'4"</b>	<b>45'11"</b>	<b>45'11"</b>	<b>45'5"</b>	<b>46'0"</b>
Static tipping load, straight (ISO)*	kg	11 952	11 812	12 132	11 881	11 740
	lb	<b>26,342</b>	<b>26,034</b>	<b>26,739</b>	<b>26,186</b>	<b>25,876</b>
Static tipping load, straight (rigid tire)*	kg	12 676	12 535	12 866	12 607	12 465
	lb	<b>27,938</b>	<b>27,627</b>	<b>28,357</b>	<b>27,786</b>	<b>27,474</b>
Static tipping load, articulated (ISO)*	kg	10 267	10 127	10 431	10 199	10 059
	lb	<b>22,629</b>	<b>22,321</b>	<b>22,990</b>	<b>22,480</b>	<b>22,171</b>
Static tipping load, articulated (rigid tire)*	kg	11 006	10 865	11 180	10 941	10 799
	lb	<b>24,259</b>	<b>23,948</b>	<b>24,641</b>	<b>24,114</b>	<b>23,802</b>
Breakout force** (§)	kN	148	146	159	143	142
	lbf	<b>33,277</b>	<b>32,999</b>	<b>35,937</b>	<b>32,256</b>	<b>31,979</b>
Operating weight*	kg	19 929	20 037	19 880	19 967	20 075
	lb	<b>43,922</b>	<b>44,160</b>	<b>43,814</b>	<b>44,006</b>	<b>44,244</b>

\*Static tipping loads and operating weights shown are based on a global machine configuration with Michelin 23.5R25 XHA2 L3 Radial tires, full fluids, operator, standard counterweight, standard linkage, cold start, roading fenders, Product Link, open differential axles (front/rear), power train guard, secondary steering, and sound suppression.

\*\*Measured 102 mm (4") behind tip of cutting edge with bucket hinge pin as pivot point in accordance with SAE J732C.

(§) Specifications and ratings conform to all applicable standards recommended by the Society of Automotive Engineers, including SAE Standard J732C governing loader ratings.

(ISO) Full compliance to ISO 14397-1 (2007) Sections 1 thru 6, which requires 2% verification between calculations and testing.

(Rigid Tire) Compliance to ISO 14397-1 (2007) Sections 1 thru 5.

**NOTE:** Bucket availability varies by region. Consult your local dealer for availability.

Bucket Type	Material Handling — Fusion QC						High Lift Change in Specs	
	Edge Type	Bolt-on Cutting Edges	Teeth & Segments	Teeth	Bolt-on Cutting Edges	Teeth & Segments		Teeth
Capacity — rated (§)	m <sup>3</sup>	3.60	3.60	3.40	3.80	3.80	3.60	—
	yd <sup>3</sup>	<b>4.71</b>	<b>4.71</b>	<b>4.45</b>	<b>4.97</b>	<b>4.97</b>	<b>4.71</b>	—
Capacity — struck (§)	m <sup>3</sup>	3.10	3.10	2.90	3.28	3.28	3.11	—
	yd <sup>3</sup>	<b>4.05</b>	<b>4.05</b>	<b>3.79</b>	<b>4.29</b>	<b>4.29</b>	<b>4.07</b>	—
Width (§)	mm	2927	2994	2994	2927	2994	2994	—
	ft/in	<b>9'7"</b>	<b>9'9"</b>	<b>9'9"</b>	<b>9'7"</b>	<b>9'9"</b>	<b>9'9"</b>	—
Dump clearance at maximum lift and 45° discharge (§)	mm	2687	2561	2561	2651	2525	2525	505
	ft/in	<b>8'9"</b>	<b>8'4"</b>	<b>8'4"</b>	<b>8'8"</b>	<b>8'3"</b>	<b>8'3"</b>	<b>1'7"</b>
Reach at maximum lift and 45° discharge (§)	mm	1480	1583	1583	1517	1619	1619	35
	ft/in	<b>4'10"</b>	<b>5'2"</b>	<b>5'2"</b>	<b>4'11"</b>	<b>5'3"</b>	<b>5'3"</b>	<b>1"</b>
Reach at level lift arm and bucket level (§)	mm	2876	3037	3037	2927	3088	3088	374
	ft/in	<b>9'5"</b>	<b>9'11"</b>	<b>9'11"</b>	<b>9'7"</b>	<b>10'1"</b>	<b>10'1"</b>	<b>1'2"</b>
Digging depth (§)	mm	90	90	60	90	90	60	4
	in	<b>3.5</b>	<b>3.5</b>	<b>2.3</b>	<b>3.5</b>	<b>3.5</b>	<b>2.3</b>	<b>0.1</b>
Overall length	mm	8350	8523	8523	8401	8574	8574	604
	ft/in	<b>27'5"</b>	<b>28'0"</b>	<b>28'0"</b>	<b>27'7"</b>	<b>28'2"</b>	<b>28'2"</b>	<b>2'0"</b>
Overall height with bucket at maximum lift	mm	5643	5643	5643	5697	5697	5697	506
	ft/in	<b>18'7"</b>	<b>18'7"</b>	<b>18'7"</b>	<b>18'9"</b>	<b>18'9"</b>	<b>18'9"</b>	<b>1'8"</b>
Loader clearance circle with bucket at carry position (§)	mm	13 867	14 040	14 040	13 898	14 073	14 073	393
	ft/in	<b>45'6"</b>	<b>46'1"</b>	<b>46'1"</b>	<b>45'8"</b>	<b>46'3"</b>	<b>46'3"</b>	<b>1'4"</b>
Static tipping load, straight (ISO)*	kg	11 798	11 657	11 974	11 700	11 558	11 875	-1279
	lb	<b>26,004</b>	<b>25,693</b>	<b>26,392</b>	<b>25,787</b>	<b>25,474</b>	<b>26,172</b>	<b>-2820</b>
Static tipping load, straight (rigid tire)*	kg	12 526	12 383	12 711	12 429	12 286	12 614	-1440
	lb	<b>27,608</b>	<b>27,293</b>	<b>28,016</b>	<b>27,394</b>	<b>27,078</b>	<b>27,801</b>	<b>-3174</b>
Static tipping load, articulated (ISO)*	kg	10 122	9980	10 282	10 028	9886	10 187	-1190
	lb	<b>22,309</b>	<b>21,998</b>	<b>22,661</b>	<b>22,101</b>	<b>21,788</b>	<b>22,452</b>	<b>-2622</b>
Static tipping load, articulated (rigid tire)*	kg	10 864	10 722	11 034	10 772	10 629	10 941	-1341
	lb	<b>23,946</b>	<b>23,631</b>	<b>24,319</b>	<b>23,743</b>	<b>23,426</b>	<b>24,114</b>	<b>-2955</b>
Breakout force** (§)	kN	138	137	149	133	132	143	-8
	lbf	<b>31,176</b>	<b>30,901</b>	<b>33,524</b>	<b>30,013</b>	<b>29,739</b>	<b>32,198</b>	<b>-1812</b>
Operating weight*	kg	20 007	20 115	19 958	20 061	20 169	20 012	602
	lb	<b>44,094</b>	<b>44,332</b>	<b>43,986</b>	<b>44,213</b>	<b>44,451</b>	<b>44,105</b>	<b>1326</b>

\*Static tipping loads and operating weights shown are based on a global machine configuration with Michelin 23.5R25 XHA2 L3 Radial tires, full fluids, operator, standard counterweight, standard linkage, cold start, roading fenders, Product Link, open differential axles (front/rear), power train guard, secondary steering, and sound suppression.

\*\*Measured 102 mm (4") behind tip of cutting edge with bucket hinge pin as pivot point in accordance with SAE J732C.

(§) Specifications and ratings conform to all applicable standards recommended by the Society of Automotive Engineers, including SAE Standard J732C governing loader ratings.

(ISO) Full compliance to ISO 14397-1 (2007) Sections 1 thru 6, which requires 2% verification between calculations and testing.

(Rigid Tire) Compliance to ISO 14397-1 (2007) Sections 1 thru 5.

**NOTE:** Bucket availability varies by region. Consult your local dealer for availability.

Bucket Type	General Purpose — Pin On									
		Bolt-on Cutting Edges	Teeth & Segments	Teeth	Bolt-on Cutting Edges	Teeth & Segments	Teeth	Bolt-on Cutting Edges	Teeth & Segments	Teeth
Edge Type										
Capacity — rated (§)	m <sup>3</sup>	2.70	2.70	2.50	2.90	2.90	2.70	3.10	3.10	2.90
	yd <sup>3</sup>	<b>3.53</b>	<b>3.53</b>	<b>3.27</b>	<b>3.79</b>	<b>3.79</b>	<b>3.53</b>	<b>4.05</b>	<b>4.05</b>	<b>3.79</b>
Capacity — struck (§)	m <sup>3</sup>	2.30	2.30	2.11	2.55	2.55	2.33	2.76	2.76	2.54
	yd <sup>3</sup>	<b>3.01</b>	<b>3.01</b>	<b>2.76</b>	<b>3.34</b>	<b>3.34</b>	<b>3.05</b>	<b>3.61</b>	<b>3.61</b>	<b>3.32</b>
Width (§)	mm	2927	2994	2994	2927	2994	2994	2927	2994	2994
	ft/in	<b>9'7"</b>	<b>9'9"</b>	<b>9'9"</b>	<b>9'7"</b>	<b>9'9"</b>	<b>9'9"</b>	<b>9'7"</b>	<b>9'9"</b>	<b>9'9"</b>
Dump clearance at maximum lift and 45° discharge (§)	mm	3191	3076	3076	3136	3019	3019	3093	2975	2975
	ft/in	<b>10'5"</b>	<b>10'1"</b>	<b>10'1"</b>	<b>10'3"</b>	<b>9'10"</b>	<b>9'10"</b>	<b>10'1"</b>	<b>9'9"</b>	<b>9'9"</b>
Reach at maximum lift and 45° discharge (§)	mm	1290	1403	1403	1328	1440	1440	1363	1474	1474
	ft/in	<b>4'2"</b>	<b>4'7"</b>	<b>4'7"</b>	<b>4'4"</b>	<b>4'8"</b>	<b>4'8"</b>	<b>4'5"</b>	<b>4'10"</b>	<b>4'10"</b>
Reach at level lift arm and bucket level (§)	mm	2660	2821	2821	2729	2890	2890	2786	2947	2947
	ft/in	<b>8'8"</b>	<b>9'3"</b>	<b>9'3"</b>	<b>8'11"</b>	<b>9'5"</b>	<b>9'5"</b>	<b>9'1"</b>	<b>9'8"</b>	<b>9'8"</b>
Digging depth (§)	mm	88	88	58	88	88	58	88	88	58
	in	<b>3.5</b>	<b>3.5</b>	<b>2.3</b>	<b>3.5</b>	<b>3.5</b>	<b>2.3</b>	<b>3.5</b>	<b>3.5</b>	<b>2.3</b>
Overall length	mm	8307	8479	8479	8376	8548	8548	8433	8605	8605
	ft/in	<b>27'4"</b>	<b>27'10"</b>	<b>27'10"</b>	<b>27'6"</b>	<b>28'1"</b>	<b>28'1"</b>	<b>27'8"</b>	<b>28'3"</b>	<b>28'3"</b>
Overall height with bucket at maximum lift	mm	5609	5609	5609	5681	5681	5681	5742	5742	5742
	ft/in	<b>18'5"</b>	<b>18'5"</b>	<b>18'5"</b>	<b>18'8"</b>	<b>18'8"</b>	<b>18'8"</b>	<b>18'11"</b>	<b>18'11"</b>	<b>18'11"</b>
Loader clearance circle with bucket at carry position (§)	mm	13 785	13 953	13 953	13 825	13 995	13 995	13 859	14 029	14 029
	ft/in	<b>45'3"</b>	<b>45'10"</b>	<b>45'10"</b>	<b>45'5"</b>	<b>45'11"</b>	<b>45'11"</b>	<b>45'6"</b>	<b>46'1"</b>	<b>46'1"</b>
Static tipping load, straight (ISO)*	kg	14 003	13 866	14 174	13 854	13 716	14 017	13 753	13 613	13 906
	lb	<b>30,863</b>	<b>30,561</b>	<b>31,240</b>	<b>30,536</b>	<b>30,230</b>	<b>30,893</b>	<b>30,312</b>	<b>30,005</b>	<b>30,651</b>
Static tipping load, straight (rigid tire)*	kg	14 746	14 608	14 925	14 601	14 461	14 770	14 502	14 362	14 662
	lb	<b>32,501</b>	<b>32,196</b>	<b>32,895</b>	<b>32,180</b>	<b>31,872</b>	<b>32,553</b>	<b>31,964</b>	<b>31,654</b>	<b>32,316</b>
Static tipping load, articulated (ISO)*	kg	12 053	11 916	12 203	11 910	11 772	12 053	11 816	11 677	11 950
	lb	<b>26,565</b>	<b>26,262</b>	<b>26,897</b>	<b>26,251</b>	<b>25,946</b>	<b>26,565</b>	<b>26,043</b>	<b>25,736</b>	<b>26,339</b>
Static tipping load, articulated (rigid tire)*	kg	12 817	12 679	12 974	12 678	12 538	12 827	12 587	12 446	12 726
	lb	<b>28,249</b>	<b>27,944</b>	<b>28,596</b>	<b>27,942</b>	<b>27,634</b>	<b>28,270</b>	<b>27,742</b>	<b>27,431</b>	<b>28,050</b>
Breakout force** (§)	kN	195	194	214	183	182	200	175	174	190
	lbf	<b>43,943</b>	<b>43,707</b>	<b>48,225</b>	<b>41,302</b>	<b>41,066</b>	<b>45,092</b>	<b>39,361</b>	<b>39,125</b>	<b>42,810</b>
Operating weight*	kg	20 252	20 360	20 203	20 336	20 444	20 287	20 373	20 481	20 324
	lb	<b>44,634</b>	<b>44,872</b>	<b>44,526</b>	<b>44,821</b>	<b>45,059</b>	<b>44,713</b>	<b>44,902</b>	<b>45,140</b>	<b>44,794</b>

\*Static tipping loads and operating weights shown are based on a global machine configuration with Michelin 23.5R25 XHA2 L3 Radial tires, full fluids, operator, standard counterweight, standard linkage, cold start, roading fenders, Product Link, open differential axles (front/rear), power train guard, secondary steering, and sound suppression.

\*\*Measured 102 mm (4") behind tip of cutting edge with bucket hinge pin as pivot point in accordance with SAE J732C.

(§) Specifications and ratings conform to all applicable standards recommended by the Society of Automotive Engineers, including SAE Standard J732C governing loader ratings.

(ISO) Full compliance to ISO 14397-1 (2007) Sections 1 thru 6, which requires 2% verification between calculations and testing.

(Rigid Tire) Compliance to ISO 14397-1 (2007) Sections 1 thru 5.

**NOTE:** Bucket availability varies by region. Consult your local dealer for availability.

Bucket Type	General Purpose — Pin On									
		Bolt-on Cutting Edges	Teeth & Segments	Teeth	Bolt-on Cutting Edges	Teeth & Segments	Teeth	Bolt-on Cutting Edges	Teeth & Segments	Teeth
Edge Type										
Capacity — rated (§)	m <sup>3</sup>	3.30	3.30	3.10	3.40	3.40	3.20	3.60	3.60	3.40
	yd <sup>3</sup>	<b>4.32</b>	<b>4.32</b>	<b>4.05</b>	<b>4.45</b>	<b>4.45</b>	<b>4.19</b>	<b>4.71</b>	<b>4.71</b>	<b>4.45</b>
Capacity — struck (§)	m <sup>3</sup>	2.94	2.94	2.72	3.04	3.04	2.81	3.18	3.18	2.94
	yd <sup>3</sup>	<b>3.85</b>	<b>3.85</b>	<b>3.56</b>	<b>3.98</b>	<b>3.98</b>	<b>3.68</b>	<b>4.16</b>	<b>4.16</b>	<b>3.85</b>
Width (§)	mm	2927	2994	2994	2927	2994	2994	2927	2994	2994
	ft/in	<b>9'7"</b>	<b>9'9"</b>	<b>9'9"</b>	<b>9'7"</b>	<b>9'9"</b>	<b>9'9"</b>	<b>9'7"</b>	<b>9'9"</b>	<b>9'9"</b>
Dump clearance at maximum lift and 45° discharge (§)	mm	3054	2936	2936	3036	2917	2917	3010	2890	2890
	ft/in	<b>10'0"</b>	<b>9'7"</b>	<b>9'7"</b>	<b>9'11"</b>	<b>9'6"</b>	<b>9'6"</b>	<b>9'10"</b>	<b>9'5"</b>	<b>9'5"</b>
Reach at maximum lift and 45° discharge (§)	mm	1392	1502	1502	1406	1516	1516	1428	1537	1537
	ft/in	<b>4'6"</b>	<b>4'11"</b>	<b>4'11"</b>	<b>4'7"</b>	<b>4'11"</b>	<b>4'11"</b>	<b>4'8"</b>	<b>5'0"</b>	<b>5'0"</b>
Reach at level lift arm and bucket level (§)	mm	2835	2996	2996	2859	3020	3020	2894	3055	3055
	ft/in	<b>9'3"</b>	<b>9'9"</b>	<b>9'9"</b>	<b>9'4"</b>	<b>9'10"</b>	<b>9'10"</b>	<b>9'5"</b>	<b>10'0"</b>	<b>10'0"</b>
Digging depth (§)	mm	88	88	58	88	88	58	88	88	58
	in	<b>3.5</b>	<b>3.5</b>	<b>2.3</b>	<b>3.5</b>	<b>3.5</b>	<b>2.3</b>	<b>3.5</b>	<b>3.5</b>	<b>2.3</b>
Overall length	mm	8482	8654	8654	8506	8678	8678	8541	8713	8713
	ft/in	<b>27'10"</b>	<b>28'5"</b>	<b>28'5"</b>	<b>27'11"</b>	<b>28'6"</b>	<b>28'6"</b>	<b>28'1"</b>	<b>28'8"</b>	<b>28'8"</b>
Overall height with bucket at maximum lift	mm	5788	5788	5788	5813	5813	5813	5847	5847	5847
	ft/in	<b>19'0"</b>	<b>19'0"</b>	<b>19'0"</b>	<b>19'1"</b>	<b>19'1"</b>	<b>19'1"</b>	<b>19'3"</b>	<b>19'3"</b>	<b>19'3"</b>
Loader clearance circle with bucket at carry position (§)	mm	13 888	14 059	14 059	13 903	14 074	14 074	13 924	14 095	14 095
	ft/in	<b>45'7"</b>	<b>46'2"</b>	<b>46'2"</b>	<b>45'8"</b>	<b>46'3"</b>	<b>46'3"</b>	<b>45'9"</b>	<b>46'3"</b>	<b>46'3"</b>
Static tipping load, straight (ISO)*	kg	13 626	13 486	13 777	13 580	13 439	13 728	13 505	13 364	13 649
	lb	<b>30,033</b>	<b>29,724</b>	<b>30,365</b>	<b>29,932</b>	<b>29,621</b>	<b>30,256</b>	<b>29,766</b>	<b>29,454</b>	<b>30,082</b>
Static tipping load, straight (rigid tire)*	kg	14 377	14 236	14 534	14 332	14 190	14 485	14 259	14 116	14 408
	lb	<b>31,688</b>	<b>31,376</b>	<b>32,034</b>	<b>31,589</b>	<b>31,276</b>	<b>31,926</b>	<b>31,427</b>	<b>31,112</b>	<b>31,755</b>
Static tipping load, articulated (ISO)*	kg	11 695	11 555	11 827	11 652	11 511	11 780	11 581	11 439	11 705
	lb	<b>25,777</b>	<b>25,468</b>	<b>26,068</b>	<b>25,681</b>	<b>25,370</b>	<b>25,964</b>	<b>25,525</b>	<b>25,213</b>	<b>25,799</b>
Static tipping load, articulated (rigid tire)*	kg	12 467	12 326	12 605	12 425	12 283	12 558	12 355	12 212	12 485
	lb	<b>27,479</b>	<b>27,167</b>	<b>27,781</b>	<b>27,385</b>	<b>27,071</b>	<b>27,679</b>	<b>27,232</b>	<b>26,917</b>	<b>27,517</b>
Breakout force** (§)	kN	168	167	182	164	163	178	160	159	173
	lbf	<b>37,784</b>	<b>37,548</b>	<b>40,971</b>	<b>37,060</b>	<b>36,824</b>	<b>40,130</b>	<b>36,047</b>	<b>35,811</b>	<b>38,958</b>
Operating weight*	kg	20 443	20 551	20 394	20 466	20 574	20 417	20 503	20 611	20 454
	lb	<b>45,055</b>	<b>45,293</b>	<b>44,947</b>	<b>45,108</b>	<b>45,346</b>	<b>45,000</b>	<b>45,188</b>	<b>45,426</b>	<b>45,080</b>

\*Static tipping loads and operating weights shown are based on a global machine configuration with Michelin 23.5R25 XHA2 L3 Radial tires, full fluids, operator, standard counterweight, standard linkage, cold start, roading fenders, Product Link, open differential axles (front/rear), power train guard, secondary steering, and sound suppression.

\*\*Measured 102 mm (4") behind tip of cutting edge with bucket hinge pin as pivot point in accordance with SAE J732C.

(§) Specifications and ratings conform to all applicable standards recommended by the Society of Automotive Engineers, including SAE Standard J732C governing loader ratings.

(ISO) Full compliance to ISO 14397-1 (2007) Sections 1 thru 6, which requires 2% verification between calculations and testing.

(Rigid Tire) Compliance to ISO 14397-1 (2007) Sections 1 thru 5.

**NOTE:** Bucket availability varies by region. Consult your local dealer for availability.

Bucket Type	General Purpose — Pin On			Material Handling — Pin On						
	Bolt-on Cutting Edges	Teeth & Segments	Teeth	Bolt-on Cutting Edges	Teeth & Segments	Teeth	Bolt-on Cutting Edges	Teeth & Segments	Teeth	
Edge Type										
Capacity — rated (§)	m <sup>3</sup>	3.80	3.80	3.60	2.70	2.70	2.50	2.90	2.90	2.70
	yd <sup>3</sup>	<b>4.97</b>	<b>4.97</b>	<b>4.71</b>	<b>3.53</b>	<b>3.53</b>	<b>3.27</b>	<b>3.79</b>	<b>3.79</b>	<b>3.53</b>
Capacity — struck (§)	m <sup>3</sup>	3.36	3.36	3.12	2.32	2.32	2.11	2.52	2.52	2.31
	yd <sup>3</sup>	<b>4.39</b>	<b>4.39</b>	<b>4.08</b>	<b>3.03</b>	<b>3.03</b>	<b>2.76</b>	<b>3.30</b>	<b>3.30</b>	<b>3.02</b>
Width (§)	mm	2927	2994	2994	2927	2994	2994	2927	2994	2994
	ft/in	<b>9'7"</b>	<b>9'9"</b>	<b>9'9"</b>	<b>9'7"</b>	<b>9'9"</b>	<b>9'9"</b>	<b>9'7"</b>	<b>9'9"</b>	<b>9'9"</b>
Dump clearance at maximum lift and 45° discharge (§)	mm	2975	2855	2855	3112	2987	2987	3070	2944	2944
	ft/in	<b>9'9"</b>	<b>9'4"</b>	<b>9'4"</b>	<b>10'2"</b>	<b>9'9"</b>	<b>9'9"</b>	<b>10'0"</b>	<b>9'7"</b>	<b>9'7"</b>
Reach at maximum lift and 45° discharge (§)	mm	1457	1566	1566	1206	1308	1308	1248	1350	1350
	ft/in	<b>4'9"</b>	<b>5'1"</b>	<b>5'1"</b>	<b>3'11"</b>	<b>4'3"</b>	<b>4'3"</b>	<b>4'1"</b>	<b>4'5"</b>	<b>4'5"</b>
Reach at level lift arm and bucket level (§)	mm	2940	3101	3101	2679	2840	2840	2739	2900	2900
	ft/in	<b>9'7"</b>	<b>10'2"</b>	<b>10'2"</b>	<b>8'9"</b>	<b>9'3"</b>	<b>9'3"</b>	<b>8'11"</b>	<b>9'6"</b>	<b>9'6"</b>
Digging depth (§)	mm	88	88	58	88	88	58	88	88	58
	in	<b>3.5</b>	<b>3.5</b>	<b>2.3</b>	<b>3.5</b>	<b>3.5</b>	<b>2.3</b>	<b>3.5</b>	<b>3.5</b>	<b>2.3</b>
Overall length	mm	8587	8759	8759	8326	8498	8498	8386	8558	8558
	ft/in	<b>28'3"</b>	<b>28'9"</b>	<b>28'9"</b>	<b>27'4"</b>	<b>27'11"</b>	<b>27'11"</b>	<b>27'7"</b>	<b>28'1"</b>	<b>28'1"</b>
Overall height with bucket at maximum lift	mm	5894	5894	5894	5835	5835	5835	5192	5192	5192
	ft/in	<b>19'5"</b>	<b>19'5"</b>	<b>19'5"</b>	<b>19'2"</b>	<b>19'2"</b>	<b>19'2"</b>	<b>17'1"</b>	<b>17'1"</b>	<b>17'1"</b>
Loader clearance circle with bucket at carry position (§)	mm	13 952	14 124	14 124	13 796	13 965	13 965	13 831	14 001	14 001
	ft/in	<b>45'10"</b>	<b>46'5"</b>	<b>46'5"</b>	<b>45'4"</b>	<b>45'10"</b>	<b>45'10"</b>	<b>45'5"</b>	<b>46'0"</b>	<b>46'0"</b>
Static tipping load, straight (ISO)*	kg	13 400	13 258	13 538	13 829	13 693	14 027	13 706	13 569	13 862
	lb	<b>29,534</b>	<b>29,220</b>	<b>29,838</b>	<b>30,480</b>	<b>30,180</b>	<b>30,917</b>	<b>30,209</b>	<b>29,906</b>	<b>30,553</b>
Static tipping load, straight (rigid tire)*	kg	14 155	14 011	14 298	14 556	14 418	14 763	14 435	14 296	14 596
	lb	<b>31,198</b>	<b>30,881</b>	<b>31,514</b>	<b>32,081</b>	<b>31,778</b>	<b>32,538</b>	<b>31,815</b>	<b>31,510</b>	<b>32,171</b>
Static tipping load, articulated (ISO)*	kg	11 481	11 339	11 600	11 899	11 763	12 078	11 783	11 646	11 921
	lb	<b>25,304</b>	<b>24,991</b>	<b>25,568</b>	<b>26,226</b>	<b>25,926</b>	<b>26,622</b>	<b>25,971</b>	<b>25,668</b>	<b>26,275</b>
Static tipping load, articulated (rigid tire)*	kg	12 257	12 113	12 381	12 647	12 510	12 835	12 534	12 395	12 676
	lb	<b>27,015</b>	<b>26,698</b>	<b>27,289</b>	<b>27,874</b>	<b>27,572</b>	<b>28,289</b>	<b>27,624</b>	<b>27,319</b>	<b>27,939</b>
Breakout force** (§)	kN	154	153	166	192	191	210	182	181	198
	lbf	<b>34,784</b>	<b>34,548</b>	<b>37,504</b>	<b>43,166</b>	<b>42,930</b>	<b>47,301</b>	<b>40,945</b>	<b>40,709</b>	<b>44,671</b>
Operating weight*	kg	20 558	20 666	20 509	20 274	20 382	20 225	20 330	20 438	20 281
	lb	<b>45,308</b>	<b>45,546</b>	<b>45,200</b>	<b>44,684</b>	<b>44,922</b>	<b>44,576</b>	<b>44,807</b>	<b>45,045</b>	<b>44,699</b>

\*Static tipping loads and operating weights shown are based on a global machine configuration with Michelin 23.5R25 XHA2 L3 Radial tires, full fluids, operator, standard counterweight, standard linkage, cold start, roading fenders, Product Link, open differential axles (front/rear), power train guard, secondary steering, and sound suppression.

\*\*Measured 102 mm (4") behind tip of cutting edge with bucket hinge pin as pivot point in accordance with SAE J732C.

(§) Specifications and ratings conform to all applicable standards recommended by the Society of Automotive Engineers, including SAE Standard J732C governing loader ratings.

(ISO) Full compliance to ISO 14397-1 (2007) Sections 1 thru 6, which requires 2% verification between calculations and testing.

(Rigid Tire) Compliance to ISO 14397-1 (2007) Sections 1 thru 5.

**NOTE:** Bucket availability varies by region. Consult your local dealer for availability.



Bucket Type	Material Handling — Pin On									
		Bolt-on Cutting Edges	Teeth & Segments	Teeth	Bolt-on Cutting Edges	Teeth & Segments	Teeth	Bolt-on Cutting Edges	Teeth & Segments	Teeth
Edge Type										
Capacity — rated (§)	m <sup>3</sup>	3.10	3.10	2.90	3.30	3.30	3.10	3.40	3.40	3.20
	yd <sup>3</sup>	<b>4.05</b>	<b>4.05</b>	<b>3.79</b>	<b>4.32</b>	<b>4.32</b>	<b>4.05</b>	<b>4.45</b>	<b>4.45</b>	<b>4.19</b>
Capacity — struck (§)	m <sup>3</sup>	2.61	2.61	2.44	2.78	2.78	2.61	2.92	2.92	2.74
	yd <sup>3</sup>	<b>3.41</b>	<b>3.41</b>	<b>3.19</b>	<b>3.64</b>	<b>3.64</b>	<b>3.41</b>	<b>3.82</b>	<b>3.82</b>	<b>3.58</b>
Width (§)	mm	2927	2994	2994	2927	2994	2994	2927	2994	2994
	ft/in	<b>9'7"</b>	<b>9'9"</b>	<b>9'9"</b>	<b>9'7"</b>	<b>9'9"</b>	<b>9'9"</b>	<b>9'7"</b>	<b>9'9"</b>	<b>9'9"</b>
Dump clearance at maximum lift and 45° discharge (§)	mm	3038	2913	2913	3006	2881	2881	2978	2852	2852
	ft/in	<b>9'11"</b>	<b>9'6"</b>	<b>9'6"</b>	<b>9'10"</b>	<b>9'5"</b>	<b>9'5"</b>	<b>9'9"</b>	<b>9'4"</b>	<b>9'4"</b>
Reach at maximum lift and 45° discharge (§)	mm	1280	1382	1382	1312	1414	1414	1340	1442	1442
	ft/in	<b>4'2"</b>	<b>4'6"</b>	<b>4'6"</b>	<b>4'3"</b>	<b>4'7"</b>	<b>4'7"</b>	<b>4'4"</b>	<b>4'8"</b>	<b>4'8"</b>
Reach at level lift arm and bucket level (§)	mm	2784	2945	2945	2829	2990	2990	2869	3030	3030
	ft/in	<b>9'1"</b>	<b>9'7"</b>	<b>9'7"</b>	<b>9'3"</b>	<b>9'9"</b>	<b>9'9"</b>	<b>9'4"</b>	<b>9'11"</b>	<b>9'11"</b>
Digging depth (§)	mm	88	88	58	88	88	58	88	88	58
	in	<b>3.5</b>	<b>3.5</b>	<b>2.3</b>	<b>3.5</b>	<b>3.5</b>	<b>2.3</b>	<b>3.5</b>	<b>3.5</b>	<b>2.3</b>
Overall length	mm	8431	8603	8603	8476	8648	8648	8516	8688	8688
	ft/in	<b>27'8"</b>	<b>28'3"</b>	<b>28'3"</b>	<b>27'10"</b>	<b>28'5"</b>	<b>28'5"</b>	<b>28'0"</b>	<b>28'7"</b>	<b>28'7"</b>
Overall height with bucket at maximum lift	mm	5700	5700	5700	5744	5744	5744	5783	5783	5783
	ft/in	<b>18'9"</b>	<b>18'9"</b>	<b>18'9"</b>	<b>18'11"</b>	<b>18'11"</b>	<b>18'11"</b>	<b>19'0"</b>	<b>19'0"</b>	<b>19'0"</b>
Loader clearance circle with bucket at carry position (§)	mm	13 858	14 028	14 028	13 885	14 055	14 055	13 909	14 080	14 080
	ft/in	<b>45'6"</b>	<b>46'1"</b>	<b>46'1"</b>	<b>45'7"</b>	<b>46'2"</b>	<b>46'2"</b>	<b>45'8"</b>	<b>46'3"</b>	<b>46'3"</b>
Static tipping load, straight (ISO)*	kg	13 608	13 469	13 757	13 511	13 372	13 656	13 427	13 288	13 568
	lb	<b>29,992</b>	<b>29,687</b>	<b>30,321</b>	<b>29,778</b>	<b>29,472</b>	<b>30,099</b>	<b>29,594</b>	<b>29,287</b>	<b>29,905</b>
Static tipping load, straight (rigid tire)*	kg	14 338	14 199	14 493	14 243	14 103	14 393	14 161	14 020	14 307
	lb	<b>31,602</b>	<b>31,295</b>	<b>31,942</b>	<b>31,392</b>	<b>31,083</b>	<b>31,723</b>	<b>31,211</b>	<b>30,901</b>	<b>31,533</b>
Static tipping load, articulated (ISO)*	kg	11 690	11 552	11 822	11 599	11 460	11 726	11 520	11 380	11 643
	lb	<b>25,766</b>	<b>25,461</b>	<b>26,055</b>	<b>25,564</b>	<b>25,258</b>	<b>25,845</b>	<b>25,390</b>	<b>25,082</b>	<b>25,662</b>
Static tipping load, articulated (rigid tire)*	kg	12 442	12 303	12 578	12 352	12 212	12 484	12 275	12 134	12 402
	lb	<b>27,423</b>	<b>27,116</b>	<b>27,723</b>	<b>27,225</b>	<b>26,916</b>	<b>27,515</b>	<b>27,054</b>	<b>26,744</b>	<b>27,336</b>
Breakout force** (§)	kN	175	174	190	168	167	183	163	162	177
	lbf	<b>39,398</b>	<b>39,162</b>	<b>42,855</b>	<b>37,957</b>	<b>37,721</b>	<b>41,173</b>	<b>36,755</b>	<b>36,519</b>	<b>39,778</b>
Operating weight*	kg	20 380	20 488	20 331	20 428	20 536	20 379	20 468	20 576	20 419
	lb	<b>44,918</b>	<b>45,156</b>	<b>44,810</b>	<b>45,023</b>	<b>45,261</b>	<b>44,915</b>	<b>45,112</b>	<b>45,350</b>	<b>45,004</b>

\*Static tipping loads and operating weights shown are based on a global machine configuration with Michelin 23.5R25 XHA2 L3 Radial tires, full fluids, operator, standard counterweight, standard linkage, cold start, roading fenders, Product Link, open differential axles (front/rear), power train guard, secondary steering, and sound suppression.

\*\*Measured 102 mm (4") behind tip of cutting edge with bucket hinge pin as pivot point in accordance with SAE J732C.

(§) Specifications and ratings conform to all applicable standards recommended by the Society of Automotive Engineers, including SAE Standard J732C governing loader ratings.

(ISO) Full compliance to ISO 14397-1 (2007) Sections 1 thru 6, which requires 2% verification between calculations and testing.

(Rigid Tire) Compliance to ISO 14397-1 (2007) Sections 1 thru 5.

**NOTE:** Bucket availability varies by region. Consult your local dealer for availability.

Bucket Type	Material Handling — Pin On						General Purpose — Fusion QC			
	Bolt-on Cutting Edges	Teeth & Segments	Teeth	Bolt-on Cutting Edges	Teeth & Segments	Teeth	Bolt-on Cutting Edges	Teeth & Segments	Teeth	
Edge Type										
Capacity — rated (§)	m <sup>3</sup> yd <sup>3</sup>	3.60 <b>4.71</b>	3.60 <b>4.71</b>	3.40 <b>4.45</b>	3.80 <b>4.97</b>	3.80 <b>4.97</b>	3.60 <b>4.71</b>	2.70 <b>3.53</b>	2.70 <b>3.53</b>	2.50 <b>3.27</b>
Capacity — struck (§)	m <sup>3</sup> yd <sup>3</sup>	3.15 <b>4.12</b>	3.15 <b>4.12</b>	2.95 <b>3.86</b>	3.28 <b>4.29</b>	3.28 <b>4.29</b>	3.11 <b>4.07</b>	2.30 <b>3.01</b>	2.30 <b>3.01</b>	2.11 <b>2.76</b>
Width (§)	mm ft/in	2927 <b>9'7"</b>	2994 <b>9'9"</b>	2994 <b>9'9"</b>	2927 <b>9'7"</b>	2994 <b>9'9"</b>	2994 <b>9'9"</b>	2927 <b>9'7"</b>	2994 <b>9'9"</b>	2994 <b>9'9"</b>
Dump clearance at maximum lift and 45° discharge (§)	mm ft/in	2946 <b>9'8"</b>	2821 <b>9'3"</b>	2821 <b>9'3"</b>	2910 <b>9'6"</b>	2785 <b>9'1"</b>	2785 <b>9'1"</b>	3153 <b>10'4"</b>	3037 <b>9'11"</b>	3037 <b>9'11"</b>
Reach at maximum lift and 45° discharge (§)	mm ft/in	1372 <b>4'6"</b>	1474 <b>4'10"</b>	1474 <b>4'10"</b>	1408 <b>4'7"</b>	1510 <b>4'11"</b>	1510 <b>4'11"</b>	1336 <b>4'4"</b>	1449 <b>4'9"</b>	1449 <b>4'9"</b>
Reach at level lift arm and bucket level (§)	mm ft/in	2914 <b>9'6"</b>	3075 <b>10'1"</b>	3075 <b>10'1"</b>	2965 <b>9'8"</b>	3126 <b>10'3"</b>	3126 <b>10'3"</b>	2720 <b>8'11"</b>	2881 <b>9'5"</b>	2881 <b>9'5"</b>
Digging depth (§)	mm in	88 <b>3.5</b>	88 <b>3.5</b>	58 <b>2.3</b>	88 <b>3.5</b>	88 <b>3.5</b>	58 <b>2.3</b>	88 <b>3.5</b>	88 <b>3.5</b>	58 <b>2.3</b>
Overall length	mm ft/in	8561 <b>28'2"</b>	8733 <b>28'8"</b>	8733 <b>28'8"</b>	8612 <b>28'4"</b>	8784 <b>28'10"</b>	8784 <b>28'10"</b>	8367 <b>27'6"</b>	8539 <b>28'1"</b>	8539 <b>28'1"</b>
Overall height with bucket at maximum lift	mm ft/in	5831 <b>19'2"</b>	5831 <b>19'2"</b>	5831 <b>19'2"</b>	5879 <b>19'4"</b>	5879 <b>19'4"</b>	5879 <b>19'4"</b>	5641 <b>18'7"</b>	5641 <b>18'7"</b>	5641 <b>18'7"</b>
Loader clearance circle with bucket at carry position (§)	mm ft/in	13 936 <b>45'9"</b>	14 108 <b>46'4"</b>	14 108 <b>46'4"</b>	13 967 <b>45'10"</b>	14 139 <b>46'5"</b>	14 139 <b>46'5"</b>	13 811 <b>45'4"</b>	13 982 <b>45'11"</b>	13 982 <b>45'11"</b>
Static tipping load, straight (ISO)*	kg lb	13 334 <b>29,389</b>	13 194 <b>29,079</b>	13 470 <b>29,689</b>	13 226 <b>29,150</b>	13 084 <b>28,838</b>	13 357 <b>29,440</b>	13 391 <b>29,515</b>	13 255 <b>29,214</b>	13 595 <b>29,963</b>
Static tipping load, straight (rigid tire)*	kg lb	14 069 <b>31,009</b>	13 927 <b>30,697</b>	14 210 <b>31,320</b>	13 962 <b>30,774</b>	13 820 <b>30,459</b>	14 098 <b>31,074</b>	14 124 <b>31,131</b>	13 987 <b>30,827</b>	14 339 <b>31,604</b>
Static tipping load, articulated (ISO)*	kg lb	11 432 <b>25,196</b>	11 291 <b>24,887</b>	11 551 <b>25,458</b>	11 329 <b>24,970</b>	11 188 <b>24,659</b>	11 443 <b>25,222</b>	11 470 <b>25,281</b>	11 333 <b>24,979</b>	11 653 <b>25,684</b>
Static tipping load, articulated (rigid tire)*	kg lb	12 188 <b>26,864</b>	12 047 <b>26,552</b>	12 311 <b>27,135</b>	12 088 <b>26,642</b>	11 945 <b>26,327</b>	12 206 <b>26,902</b>	12 225 <b>26,944</b>	12 087 <b>26,640</b>	12 419 <b>27,371</b>
Breakout force** (§)	kN lbf	157 <b>35,483</b>	156 <b>35,247</b>	170 <b>38,308</b>	151 <b>34,128</b>	150 <b>33,891</b>	163 <b>36,751</b>	185 <b>41,637</b>	184 <b>41,401</b>	202 <b>45,487</b>
Operating weight*	kg lb	20 512 <b>45,208</b>	20 620 <b>45,446</b>	20 463 <b>45,100</b>	20 566 <b>45,327</b>	20 674 <b>45,565</b>	20 517 <b>45,219</b>	20 726 <b>45,680</b>	20 834 <b>45,918</b>	20 677 <b>45,572</b>

\*Static tipping loads and operating weights shown are based on a global machine configuration with Michelin 23.5R25 XHA2 L3 Radial tires, full fluids, operator, standard counterweight, standard linkage, cold start, roading fenders, Product Link, open differential axles (front/rear), power train guard, secondary steering, and sound suppression.

\*\*Measured 102 mm (4") behind tip of cutting edge with bucket hinge pin as pivot point in accordance with SAE J732C.

(§) Specifications and ratings conform to all applicable standards recommended by the Society of Automotive Engineers, including SAE Standard J732C governing loader ratings.

(ISO) Full compliance to ISO 14397-1 (2007) Sections 1 thru 6, which requires 2% verification between calculations and testing.

(Rigid Tire) Compliance to ISO 14397-1 (2007) Sections 1 thru 5.

**NOTE:** Bucket availability varies by region. Consult your local dealer for availability.

Bucket Type		General Purpose — Fusion QC								
		Bolt-on Cutting Edges	Teeth & Segments	Teeth	Bolt-on Cutting Edges	Teeth & Segments	Teeth	Bolt-on Cutting Edges	Teeth & Segments	Teeth
Edge Type										
	Capacity — rated (§)	m <sup>3</sup> yd <sup>3</sup>	2.90 <b>3.79</b>	2.90 <b>3.79</b>	2.70 <b>3.53</b>	3.10 <b>4.05</b>	3.10 <b>4.05</b>	2.90 <b>3.79</b>	3.30 <b>4.32</b>	3.30 <b>4.32</b>
Capacity — struck (§)	m <sup>3</sup> yd <sup>3</sup>	2.55 <b>3.34</b>	2.55 <b>3.34</b>	2.33 <b>3.05</b>	2.76 <b>3.61</b>	2.76 <b>3.61</b>	2.54 <b>3.32</b>	2.94 <b>3.85</b>	2.94 <b>3.85</b>	2.72 <b>3.56</b>
	Width (§)	mm ft/in	2927 <b>9'7"</b>	2994 <b>9'9"</b>	2994 <b>9'9"</b>	2927 <b>9'7"</b>	2994 <b>9'9"</b>	2994 <b>9'9"</b>	2927 <b>9'7"</b>	2994 <b>9'9"</b>
Dump clearance at maximum lift and 45° discharge (§)	mm ft/in	3097 <b>10'1"</b>	2980 <b>9'9"</b>	2980 <b>9'9"</b>	3053 <b>10'0"</b>	2935 <b>9'7"</b>	2935 <b>9'7"</b>	3015 <b>9'10"</b>	2896 <b>9'6"</b>	2896 <b>9'6"</b>
	Reach at maximum lift and 45° discharge (§)	mm ft/in	1374 <b>4'6"</b>	1485 <b>4'10"</b>	1485 <b>4'10"</b>	1408 <b>4'7"</b>	1519 <b>4'11"</b>	1519 <b>4'11"</b>	1437 <b>4'8"</b>	1547 <b>5'0"</b>
Reach at level lift arm and bucket level (§)	mm ft/in	2789 <b>9'1"</b>	2950 <b>9'8"</b>	2950 <b>9'8"</b>	2846 <b>9'4"</b>	3007 <b>9'10"</b>	3007 <b>9'10"</b>	2895 <b>9'5"</b>	3056 <b>10'0"</b>	3056 <b>10'0"</b>
	Digging depth (§)	mm in	88 <b>3.5</b>	88 <b>3.5</b>	58 <b>2.3</b>	88 <b>3.5</b>	88 <b>3.5</b>	58 <b>2.3</b>	88 <b>3.5</b>	88 <b>3.5</b>
Overall length	mm ft/in	8436 <b>27'9"</b>	8608 <b>28'3"</b>	8608 <b>28'3"</b>	8493 <b>27'11"</b>	8665 <b>28'6"</b>	8665 <b>28'6"</b>	8542 <b>28'1"</b>	8714 <b>28'8"</b>	8714 <b>28'8"</b>
	Overall height with bucket at maximum lift	mm ft/in	5714 <b>18'9"</b>	5714 <b>18'9"</b>	5714 <b>18'9"</b>	5775 <b>19'0"</b>	5775 <b>19'0"</b>	5775 <b>19'0"</b>	5821 <b>19'2"</b>	5821 <b>19'2"</b>
Loader clearance circle with bucket at carry position (§)	mm ft/in	13 852 <b>45'6"</b>	14 024 <b>46'1"</b>	14 024 <b>46'1"</b>	13 887 <b>45'7"</b>	14 060 <b>46'2"</b>	14 060 <b>46'2"</b>	13 917 <b>45'8"</b>	14 090 <b>46'3"</b>	14 090 <b>46'3"</b>
	Static tipping load, straight (ISO)*	kg lb	13 270 <b>29,247</b>	13 132 <b>28,943</b>	13 468 <b>29,685</b>	13 152 <b>28,988</b>	13 013 <b>28,682</b>	13 348 <b>29,421</b>	13 056 <b>28,776</b>	12 916 <b>28,467</b>
Static tipping load, straight (rigid tire)*		kg lb	14 006 <b>30,870</b>	13 867 <b>30,563</b>	14 215 <b>31,331</b>	13 891 <b>30,616</b>	13 751 <b>30,307</b>	14 098 <b>31,072</b>	13 796 <b>30,408</b>	13 655 <b>30,097</b>
	Static tipping load, articulated (ISO)*	kg lb	11 355 <b>25,027</b>	11 217 <b>24,722</b>	11 534 <b>25,421</b>	11 244 <b>24,783</b>	11 105 <b>24,477</b>	11 421 <b>25,173</b>	11 154 <b>24,583</b>	11 014 <b>24,275</b>
Static tipping load, articulated (rigid tire)*		kg lb	12 112 <b>26,696</b>	11 973 <b>26,389</b>	12 302 <b>27,114</b>	12 004 <b>26,458</b>	11 864 <b>26,149</b>	12 192 <b>26,872</b>	11 915 <b>26,262</b>	11 774 <b>25,951</b>
	Breakout force** (§)	kN lbf	174 <b>39,256</b>	173 <b>39,020</b>	190 <b>42,687</b>	166 <b>37,469</b>	165 <b>37,233</b>	180 <b>40,603</b>	160 <b>36,044</b>	159 <b>35,808</b>
Operating weight*		kg lb	20 789 <b>45,818</b>	20 897 <b>46,056</b>	20 740 <b>45,710</b>	20 843 <b>45,937</b>	20 951 <b>46,175</b>	20 794 <b>45,829</b>	20 889 <b>46,039</b>	20 997 <b>46,277</b>

\*Static tipping loads and operating weights shown are based on a global machine configuration with Michelin 23.5R25 XHA2 L3 Radial tires, full fluids, operator, standard counterweight, standard linkage, cold start, roading fenders, Product Link, open differential axles (front/rear), power train guard, secondary steering, and sound suppression.

\*\*Measured 102 mm (4") behind tip of cutting edge with bucket hinge pin as pivot point in accordance with SAE J732C.

(§) Specifications and ratings conform to all applicable standards recommended by the Society of Automotive Engineers, including SAE Standard J732C governing loader ratings.

(ISO) Full compliance to ISO 14397-1 (2007) Sections 1 thru 6, which requires 2% verification between calculations and testing.

(Rigid Tire) Compliance to ISO 14397-1 (2007) Sections 1 thru 5.

**NOTE:** Bucket availability varies by region. Consult your local dealer for availability.

Bucket Type		General Purpose — Fusion QC									
		Bolt-on Cutting Edges	Teeth & Segments	Teeth	Bolt-on Cutting Edges	Teeth & Segments	Teeth	Bolt-on Cutting Edges	Teeth & Segments	Teeth	
Edge Type											
	Capacity — rated (§)	m <sup>3</sup>	3.40	3.40	3.20	3.60	3.60	3.40	3.80	3.80	3.60
		yd <sup>3</sup>	<b>4.45</b>	<b>4.45</b>	<b>4.19</b>	<b>4.71</b>	<b>4.71</b>	<b>4.45</b>	<b>4.97</b>	<b>4.97</b>	<b>4.71</b>
Capacity — struck (§)		m <sup>3</sup>	3.04	3.04	2.81	3.18	3.18	2.94	3.36	3.36	3.12
		yd <sup>3</sup>	<b>3.98</b>	<b>3.98</b>	<b>3.68</b>	<b>4.16</b>	<b>4.16</b>	<b>3.85</b>	<b>4.39</b>	<b>4.39</b>	<b>4.08</b>
Width (§)		mm	2927	2994	2994	2927	2994	2994	2927	2994	2994
		ft/in	<b>9'7"</b>	<b>9'9"</b>	<b>9'9"</b>	<b>9'7"</b>	<b>9'9"</b>	<b>9'9"</b>	<b>9'7"</b>	<b>9'9"</b>	<b>9'9"</b>
Dump clearance at maximum lift and 45° discharge (§)		mm	2996	2877	2877	2970	2850	2850	2935	2815	2815
		ft/in	<b>9'9"</b>	<b>9'5"</b>	<b>9'5"</b>	<b>9'8"</b>	<b>9'4"</b>	<b>9'4"</b>	<b>9'7"</b>	<b>9'2"</b>	<b>9'2"</b>
Reach at maximum lift and 45° discharge (§)		mm	1451	1561	1561	1473	1582	1582	1502	1611	1611
		ft/in	<b>4'9"</b>	<b>5'1"</b>	<b>5'1"</b>	<b>4'10"</b>	<b>5'2"</b>	<b>5'2"</b>	<b>4'11"</b>	<b>5'3"</b>	<b>5'3"</b>
Reach at level lift arm and bucket level (§)		mm	2919	3080	3080	2954	3115	3115	3000	3161	3161
		ft/in	<b>9'6"</b>	<b>10'1"</b>	<b>10'1"</b>	<b>9'8"</b>	<b>10'2"</b>	<b>10'2"</b>	<b>9'10"</b>	<b>10'4"</b>	<b>10'4"</b>
Digging depth (§)		mm	88	88	58	88	88	58	88	88	58
		in	<b>3.5</b>	<b>3.5</b>	<b>2.3</b>	<b>3.5</b>	<b>3.5</b>	<b>2.3</b>	<b>3.5</b>	<b>3.5</b>	<b>2.3</b>
Overall length		mm	8566	8738	8738	8601	8773	8773	8647	8819	8819
		ft/in	<b>28'2"</b>	<b>28'9"</b>	<b>28'9"</b>	<b>28'3"</b>	<b>28'10"</b>	<b>28'10"</b>	<b>28'5"</b>	<b>29'0"</b>	<b>29'0"</b>
Overall height with bucket at maximum lift		mm	5847	5847	5847	5881	5881	5928	5928	5928	5928
		ft/in	<b>19'3"</b>	<b>19'3"</b>	<b>19'3"</b>	<b>19'4"</b>	<b>19'4"</b>	<b>19'4"</b>	<b>19'6"</b>	<b>19'6"</b>	<b>19'6"</b>
Loader clearance circle with bucket at carry position (§)		mm	13 932	14 105	14 105	13 953	14 127	14 127	13 982	14 157	14 157
		ft/in	<b>45'9"</b>	<b>46'4"</b>	<b>46'4"</b>	<b>45'10"</b>	<b>46'5"</b>	<b>46'5"</b>	<b>45'11"</b>	<b>46'6"</b>	<b>46'6"</b>
Static tipping load, straight (ISO)*		kg	13 011	12 871	13 204	12 941	12 800	13 132	12 849	12 708	13 039
		lb	<b>28,677</b>	<b>28,368</b>	<b>29,102</b>	<b>28,524</b>	<b>28,213</b>	<b>28,945</b>	<b>28,321</b>	<b>28,008</b>	<b>28,738</b>
Static tipping load, straight (rigid tire)*		kg	13 753	13 611	13 956	13 684	13 542	13 886	13 594	13 451	13 794
		lb	<b>30,312</b>	<b>29,999</b>	<b>30,759</b>	<b>30,161</b>	<b>29,847</b>	<b>30,605</b>	<b>29,962</b>	<b>29,646</b>	<b>30,402</b>
Static tipping load, articulated (ISO)*		kg	11 111	10 971	11 285	11 045	10 904	11 218	10 959	10 817	11 129
		lb	<b>24,490</b>	<b>24,180</b>	<b>24,872</b>	<b>24,344</b>	<b>24,034</b>	<b>24,724</b>	<b>24,153</b>	<b>23,841</b>	<b>24,530</b>
Static tipping load, articulated (rigid tire)*		kg	11 874	11 732	12 058	11 810	11 667	11 992	11 724	11 581	11 905
		lb	<b>26,171</b>	<b>25,859</b>	<b>26,577</b>	<b>26,029</b>	<b>25,715</b>	<b>26,431</b>	<b>25,841</b>	<b>25,526</b>	<b>26,240</b>
Breakout force** (§)		kN	157	156	169	153	152	165	148	147	159
		lbf	<b>35,379</b>	<b>35,143</b>	<b>38,186</b>	<b>34,449</b>	<b>34,213</b>	<b>37,117</b>	<b>33,289</b>	<b>33,053</b>	<b>35,789</b>
Operating weight*		kg	20 913	21 021	20 864	20 947	21 055	20 898	20 992	21 100	20 943
		lb	<b>46,091</b>	<b>46,329</b>	<b>45,983</b>	<b>46,166</b>	<b>46,404</b>	<b>46,058</b>	<b>46,265</b>	<b>46,503</b>	<b>46,157</b>

\*Static tipping loads and operating weights shown are based on a global machine configuration with Michelin 23.5R25 XHA2 L3 Radial tires, full fluids, operator, standard counterweight, standard linkage, cold start, roading fenders, Product Link, open differential axles (front/rear), power train guard, secondary steering, and sound suppression.

\*\*Measured 102 mm (4") behind tip of cutting edge with bucket hinge pin as pivot point in accordance with SAE J732C.

(§) Specifications and ratings conform to all applicable standards recommended by the Society of Automotive Engineers, including SAE Standard J732C governing loader ratings.

(ISO) Full compliance to ISO 14397-1 (2007) Sections 1 thru 6, which requires 2% verification between calculations and testing.

(Rigid Tire) Compliance to ISO 14397-1 (2007) Sections 1 thru 5.

**NOTE:** Bucket availability varies by region. Consult your local dealer for availability.

Bucket Type		Material Handling — Fusion QC									
		Bolt-on Cutting Edges	Teeth & Segments	Teeth	Bolt-on Cutting Edges	Teeth & Segments	Teeth	Bolt-on Cutting Edges	Teeth & Segments	Teeth	
Edge Type											
	Capacity — rated (§)	m <sup>3</sup>	2.70	2.70	2.50	2.90	2.90	2.70	3.10	3.10	2.90
		yd <sup>3</sup>	<b>3.53</b>	<b>3.53</b>	<b>3.27</b>	<b>3.79</b>	<b>3.79</b>	<b>3.53</b>	<b>4.05</b>	<b>4.05</b>	<b>3.79</b>
Capacity — struck (§)		m <sup>3</sup>	2.20	2.20	2.00	2.40	2.40	2.20	2.61	2.61	2.44
		yd <sup>3</sup>	<b>2.88</b>	<b>2.88</b>	<b>2.62</b>	<b>3.14</b>	<b>3.14</b>	<b>2.88</b>	<b>3.41</b>	<b>3.41</b>	<b>3.19</b>
Width (§)		mm	2927	2994	2994	2927	2994	2994	2927	2994	2994
		ft/in	<b>9'7"</b>	<b>9'9"</b>	<b>9'9"</b>	<b>9'7"</b>	<b>9'9"</b>	<b>9'9"</b>	<b>9'7"</b>	<b>9'9"</b>	<b>9'9"</b>
Dump clearance at maximum lift and 45° discharge (§)		mm	3070	2944	2944	3027	2902	2902	2996	2870	2870
		ft/in	<b>10'0"</b>	<b>9'7"</b>	<b>9'7"</b>	<b>9'11"</b>	<b>9'6"</b>	<b>9'6"</b>	<b>9'9"</b>	<b>9'5"</b>	<b>9'5"</b>
Reach at maximum lift and 45° discharge (§)		mm	1248	1350	1350	1290	1393	1393	1322	1424	1424
		ft/in	<b>4'1"</b>	<b>4'5"</b>	<b>4'5"</b>	<b>4'2"</b>	<b>4'6"</b>	<b>4'6"</b>	<b>4'4"</b>	<b>4'8"</b>	<b>4'8"</b>
Reach at level lift arm and bucket level (§)		mm	2739	2900	2900	2799	2960	2960	2844	3005	3005
		ft/in	<b>8'11"</b>	<b>9'6"</b>	<b>9'6"</b>	<b>9'2"</b>	<b>9'8"</b>	<b>9'8"</b>	<b>9'3"</b>	<b>9'10"</b>	<b>9'10"</b>
Digging depth (§)		mm	88	88	58	88	88	58	88	88	58
		in	<b>3.5</b>	<b>3.5</b>	<b>2.3</b>	<b>3.5</b>	<b>3.5</b>	<b>2.3</b>	<b>3.5</b>	<b>3.5</b>	<b>2.3</b>
Overall length		mm	8386	8558	8558	8446	8618	8618	8491	8663	8663
		ft/in	<b>27'7"</b>	<b>28'1"</b>	<b>28'1"</b>	<b>27'9"</b>	<b>28'4"</b>	<b>28'4"</b>	<b>27'11"</b>	<b>28'6"</b>	<b>28'6"</b>
Overall height with bucket at maximum lift		mm	5634	5634	5634	5697	5697	5697	5734	5734	5734
		ft/in	<b>18'6"</b>	<b>18'6"</b>	<b>18'6"</b>	<b>18'9"</b>	<b>18'9"</b>	<b>18'9"</b>	<b>18'10"</b>	<b>18'10"</b>	<b>18'10"</b>
Loader clearance circle with bucket at carry position (§)		mm	13 822	13 994	13 994	13 858	14 030	14 030	13 886	14 058	14 058
		ft/in	<b>45'5"</b>	<b>45'11"</b>	<b>45'11"</b>	<b>45'6"</b>	<b>46'1"</b>	<b>46'1"</b>	<b>45'7"</b>	<b>46'2"</b>	<b>46'2"</b>
Static tipping load, straight (ISO)*		kg	13 244	13 108	13 434	13 132	12 995	13 317	13 035	12 897	13 219
		lb	<b>29,190</b>	<b>28,891</b>	<b>29,609</b>	<b>28,943</b>	<b>28,641</b>	<b>29,352</b>	<b>28,729</b>	<b>28,426</b>	<b>29,136</b>
Static tipping load, straight (rigid tire)*		kg	13 961	13 824	14 160	13 851	13 713	14 046	13 756	13 617	13 949
		lb	<b>30,771</b>	<b>30,470</b>	<b>31,210</b>	<b>30,529</b>	<b>30,225</b>	<b>30,957</b>	<b>30,318</b>	<b>30,012</b>	<b>30,744</b>
Static tipping load, articulated (ISO)*		kg	11 342	11 207	11 514	11 237	11 100	11 405	11 145	11 008	11 312
		lb	<b>24,999</b>	<b>24,700</b>	<b>25,378</b>	<b>24,767</b>	<b>24,465</b>	<b>25,137</b>	<b>24,565</b>	<b>24,261</b>	<b>24,933</b>
Static tipping load, articulated (rigid tire)*		kg	12 082	11 945	12 262	11 978	11 840	12 155	11 888	11 749	12 064
		lb	<b>26,628</b>	<b>26,327</b>	<b>27,026</b>	<b>26,401</b>	<b>26,097</b>	<b>26,790</b>	<b>26,202</b>	<b>25,896</b>	<b>26,589</b>
Breakout force** (§)		kN	182	181	198	173	172	188	166	165	180
		lbf	<b>40,950</b>	<b>40,714</b>	<b>44,677</b>	<b>38,931</b>	<b>38,695</b>	<b>42,307</b>	<b>37,518</b>	<b>37,282</b>	<b>40,662</b>
Operating weight*		kg	20 732	20 840	20 683	20 784	20 892	20 735	20 833	20 941	20 784
		lb	<b>45,693</b>	<b>45,931</b>	<b>45,585</b>	<b>45,807</b>	<b>46,045</b>	<b>45,699</b>	<b>45,915</b>	<b>46,153</b>	<b>45,807</b>

\*Static tipping loads and operating weights shown are based on a global machine configuration with Michelin 23.5R25 XHA2 L3 Radial tires, full fluids, operator, standard counterweight, standard linkage, cold start, roading fenders, Product Link, open differential axles (front/rear), power train guard, secondary steering, and sound suppression.

\*\*Measured 102 mm (4") behind tip of cutting edge with bucket hinge pin as pivot point in accordance with SAE J732C.

(§) Specifications and ratings conform to all applicable standards recommended by the Society of Automotive Engineers, including SAE Standard J732C governing loader ratings.

(ISO) Full compliance to ISO 14397-1 (2007) Sections 1 thru 6, which requires 2% verification between calculations and testing.

(Rigid Tire) Compliance to ISO 14397-1 (2007) Sections 1 thru 5.

**NOTE:** Bucket availability varies by region. Consult your local dealer for availability.

Bucket Type	Material Handling — Fusion QC						
	Edge Type	Bolt-on Cutting Edges	Teeth & Segments	Teeth	Bolt-on Cutting Edges	Teeth & Segments	Teeth
Capacity — rated (§)	m <sup>3</sup>	3.30	3.30	3.10	3.40	3.40	3.20
	yd <sup>3</sup>	<b>4.32</b>	<b>4.32</b>	<b>4.05</b>	<b>4.45</b>	<b>4.45</b>	<b>4.19</b>
Capacity — struck (§)	m <sup>3</sup>	2.78	2.78	2.61	2.92	2.92	2.74
	yd <sup>3</sup>	<b>3.64</b>	<b>3.64</b>	<b>3.41</b>	<b>3.82</b>	<b>3.82</b>	<b>3.58</b>
Width (§)	mm	2927	2994	2994	2927	2994	2994
	ft/in	<b>9'7"</b>	<b>9'9"</b>	<b>9'9"</b>	<b>9'7"</b>	<b>9'9"</b>	<b>9'9"</b>
Dump clearance at maximum lift and 45° discharge (§)	mm	2964	2838	2838	2936	2810	2810
	ft/in	<b>9'8"</b>	<b>9'3"</b>	<b>9'3"</b>	<b>9'7"</b>	<b>9'2"</b>	<b>9'2"</b>
Reach at maximum lift and 45° discharge (§)	mm	1354	1456	1456	1382	1485	1485
	ft/in	<b>4'5"</b>	<b>4'9"</b>	<b>4'9"</b>	<b>4'6"</b>	<b>4'10"</b>	<b>4'10"</b>
Reach at level lift arm and bucket level (§)	mm	2889	3050	3050	2929	3090	3090
	ft/in	<b>9'5"</b>	<b>10'0"</b>	<b>10'0"</b>	<b>9'7"</b>	<b>10'1"</b>	<b>10'1"</b>
Digging depth (§)	mm	88	88	58	88	88	58
	in	<b>3.5</b>	<b>3.5</b>	<b>2.3</b>	<b>3.5</b>	<b>3.5</b>	<b>2.3</b>
Overall length	mm	8536	8708	8708	8576	8748	8748
	ft/in	<b>28'1"</b>	<b>28'7"</b>	<b>28'7"</b>	<b>28'2"</b>	<b>28'9"</b>	<b>28'9"</b>
Overall height with bucket at maximum lift	mm	5778	5778	5778	5817	5817	5817
	ft/in	<b>19'0"</b>	<b>19'0"</b>	<b>19'0"</b>	<b>19'1"</b>	<b>19'1"</b>	<b>19'1"</b>
Loader clearance circle with bucket at carry position (§)	mm	13 913	14 086	14 086	13 938	14 112	14 112
	ft/in	<b>45'8"</b>	<b>46'3"</b>	<b>46'3"</b>	<b>45'9"</b>	<b>46'4"</b>	<b>46'4"</b>
Static tipping load, straight (ISO)*	kg	12 943	12 804	13 130	12 867	12 728	13 050
	lb	<b>28,526</b>	<b>28,221</b>	<b>28,939</b>	<b>28,359</b>	<b>28,053</b>	<b>28,763</b>
Static tipping load, straight (rigid tire)*	kg	13 665	13 525	13 862	13 591	13 451	13 783
	lb	<b>30,118</b>	<b>29,810</b>	<b>30,552</b>	<b>29,955</b>	<b>29,646</b>	<b>30,378</b>
Static tipping load, articulated (ISO)*	kg	11 059	10 920	11 228	10 987	10 848	11 153
	lb	<b>24,374</b>	<b>24,069</b>	<b>24,747</b>	<b>24,216</b>	<b>23,909</b>	<b>24,581</b>
Static tipping load, articulated (rigid tire)*	kg	11 803	11 663	11 981	11 733	11 593	11 907
	lb	<b>26,014</b>	<b>25,706</b>	<b>26,407</b>	<b>25,860</b>	<b>25,551</b>	<b>26,244</b>
Breakout force** (§)	kN	161	160	174	156	155	168
	lbf	<b>36,201</b>	<b>35,965</b>	<b>39,135</b>	<b>35,098</b>	<b>34,862</b>	<b>37,864</b>
Operating weight*	kg	20 877	20 985	20 828	20 915	21 023	20 866
	lb	<b>46,012</b>	<b>46,250</b>	<b>45,904</b>	<b>46,096</b>	<b>46,334</b>	<b>45,988</b>

\*Static tipping loads and operating weights shown are based on a global machine configuration with Michelin 23.5R25 XHA2 L3 Radial tires, full fluids, operator, standard counterweight, standard linkage, cold start, roading fenders, Product Link, open differential axles (front/rear), power train guard, secondary steering, and sound suppression.

\*\*Measured 102 mm (4") behind tip of cutting edge with bucket hinge pin as pivot point in accordance with SAE J732C.

(§) Specifications and ratings conform to all applicable standards recommended by the Society of Automotive Engineers, including SAE Standard J732C governing loader ratings.

(ISO) Full compliance to ISO 14397-1 (2007) Sections 1 thru 6, which requires 2% verification between calculations and testing.

(Rigid Tire) Compliance to ISO 14397-1 (2007) Sections 1 thru 5.

**NOTE:** Bucket availability varies by region. Consult your local dealer for availability.

Bucket Type	Material Handling — Fusion QC						High Lift Change in Specs
	Bolt-on Cutting Edges	Teeth & Segments	Teeth	Bolt-on Cutting Edges	Teeth & Segments	Teeth	
Edge Type							
Capacity — rated (§)	m <sup>3</sup>	3.60	3.60	3.40	3.80	3.80	3.60
	yd <sup>3</sup>	<b>4.71</b>	<b>4.71</b>	<b>4.45</b>	<b>4.97</b>	<b>4.97</b>	<b>4.71</b>
Capacity — struck (§)	m <sup>3</sup>	3.10	3.10	2.90	3.28	3.28	3.11
	yd <sup>3</sup>	<b>4.05</b>	<b>4.05</b>	<b>3.79</b>	<b>4.29</b>	<b>4.29</b>	<b>4.07</b>
Width (§)	mm	2927	2994	2994	2927	2994	2994
	ft/in	<b>9'7"</b>	<b>9'9"</b>	<b>9'9"</b>	<b>9'7"</b>	<b>9'9"</b>	<b>9'9"</b>
Dump clearance at maximum lift and 45° discharge (§)	mm	2904	2778	2778	2868	2742	2742
	ft/in	<b>9'6"</b>	<b>9'1"</b>	<b>9'1"</b>	<b>9'4"</b>	<b>8'11"</b>	<b>8'11"</b>
Reach at maximum lift and 45° discharge (§)	mm	1414	1516	1516	1450	1552	1552
	ft/in	<b>4'7"</b>	<b>4'11"</b>	<b>4'11"</b>	<b>4'9"</b>	<b>5'1"</b>	<b>5'1"</b>
Reach at level lift arm and bucket level (§)	mm	2974	3135	3135	3025	3186	3186
	ft/in	<b>9'9"</b>	<b>10'3"</b>	<b>10'3"</b>	<b>9'11"</b>	<b>10'5"</b>	<b>10'5"</b>
Digging depth (§)	mm	88	88	58	88	88	58
	in	<b>3.5</b>	<b>3.5</b>	<b>2.3</b>	<b>3.5</b>	<b>3.5</b>	<b>2.3</b>
Overall length	mm	8621	8793	8793	8672	8844	8844
	ft/in	<b>28'4"</b>	<b>28'11"</b>	<b>28'11"</b>	<b>28'6"</b>	<b>29'1"</b>	<b>29'1"</b>
Overall height with bucket at maximum lift	mm	5860	5860	5860	5913	5913	5913
	ft/in	<b>19'3"</b>	<b>19'3"</b>	<b>19'3"</b>	<b>19'5"</b>	<b>19'5"</b>	<b>19'5"</b>
Loader clearance circle with bucket at carry position (§)	mm	13 966	14 140	14 140	13 998	14 173	14 173
	ft/in	<b>45'10"</b>	<b>46'5"</b>	<b>46'5"</b>	<b>46'0"</b>	<b>46'6"</b>	<b>46'6"</b>
Static tipping load, straight (ISO)*	kg	12 779	12 639	12 962	12 674	12 533	12 856
	lb	<b>28,166</b>	<b>27,857</b>	<b>28,568</b>	<b>27,935</b>	<b>27,624</b>	<b>28,335</b>
Static tipping load, straight (rigid tire)*	kg	13 504	13 363	13 696	13 401	13 259	13 592
	lb	<b>29,764</b>	<b>29,453</b>	<b>30,187</b>	<b>29,537</b>	<b>29,223</b>	<b>29,957</b>
Static tipping load, articulated (ISO)*	kg	10 905	10 765	11 070	10 805	10 665	10 970
	lb	<b>24,034</b>	<b>23,726</b>	<b>24,398</b>	<b>23,816</b>	<b>23,505</b>	<b>24,178</b>
Static tipping load, articulated (rigid tire)*	kg	11 652	11 511	11 826	11 554	11 412	11 728
	lb	<b>25,681</b>	<b>25,370</b>	<b>26,065</b>	<b>25,466</b>	<b>25,153</b>	<b>25,848</b>
Breakout force** (§)	kN	151	149	162	145	144	156
	lbf	<b>33,932</b>	<b>33,696</b>	<b>36,525</b>	<b>32,677</b>	<b>32,440</b>	<b>35,091</b>
Operating weight*	kg	20 955	21 063	20 906	21 009	21 117	20 960
	lb	<b>46,184</b>	<b>46,422</b>	<b>46,076</b>	<b>46,303</b>	<b>46,541</b>	<b>46,195</b>

\*Static tipping loads and operating weights shown are based on a global machine configuration with Michelin 23.5R25 XHA2 L3 Radial tires, full fluids, operator, standard counterweight, standard linkage, cold start, roading fenders, Product Link, open differential axles (front/rear), power train guard, secondary steering, and sound suppression.

\*\*Measured 102 mm (4") behind tip of cutting edge with bucket hinge pin as pivot point in accordance with SAE J732C.

(§) Specifications and ratings conform to all applicable standards recommended by the Society of Automotive Engineers, including SAE Standard J732C governing loader ratings.

(ISO) Full compliance to ISO 14397-1 (2007) Sections 1 thru 6, which requires 2% verification between calculations and testing.

(Rigid Tire) Compliance to ISO 14397-1 (2007) Sections 1 thru 5.

**NOTE:** Bucket availability varies by region. Consult your local dealer for availability.

Bucket Type		General Purpose — Pin On									
		Bolt-on Cutting Edges	Teeth & Segments	Teeth	Bolt-on Cutting Edges	Teeth & Segments	Teeth	Bolt-on Cutting Edges	Teeth & Segments	Teeth	
Edge Type											
	Capacity — rated (§)	m <sup>3</sup>	3.80	3.80	3.60	4.00	4.00	3.80	4.20	4.20	4.00
		yd <sup>3</sup>	<b>4.97</b>	<b>4.97</b>	<b>4.71</b>	<b>5.23</b>	<b>5.23</b>	<b>4.97</b>	<b>5.49</b>	<b>5.49</b>	<b>5.23</b>
Capacity — struck (§)		m <sup>3</sup>	3.24	3.24	3.09	3.50	3.50	3.34	3.80	3.80	3.60
		yd <sup>3</sup>	<b>4.24</b>	<b>4.24</b>	<b>4.04</b>	<b>4.58</b>	<b>4.58</b>	<b>4.37</b>	<b>4.97</b>	<b>4.97</b>	<b>4.71</b>
Width (§)		mm	3220	3271	3271	3220	3271	3271	3220	3271	3271
		ft/in	<b>10'6"</b>	<b>10'8"</b>	<b>10'8"</b>	<b>10'6"</b>	<b>10'8"</b>	<b>10'8"</b>	<b>10'6"</b>	<b>10'8"</b>	<b>10'8"</b>
Dump clearance at maximum lift and 45° discharge (§)		mm	3067	2915	2915	3058	2905	2905	2991	2837	2837
		ft/in	<b>10'0"</b>	<b>9'6"</b>	<b>9'6"</b>	<b>10'0"</b>	<b>9'6"</b>	<b>9'6"</b>	<b>9'9"</b>	<b>9'3"</b>	<b>9'3"</b>
Reach at maximum lift and 45° discharge (§)		mm	1327	1467	1467	1334	1473	1473	1388	1525	1525
		ft/in	<b>4'4"</b>	<b>4'9"</b>	<b>4'9"</b>	<b>4'4"</b>	<b>4'10"</b>	<b>4'10"</b>	<b>4'6"</b>	<b>5'0"</b>	<b>5'0"</b>
Reach at level lift arm and bucket level (§)		mm	2739	2943	2943	2750	2955	2955	2838	3043	3043
		ft/in	<b>8'11"</b>	<b>9'7"</b>	<b>9'7"</b>	<b>9'0"</b>	<b>9'8"</b>	<b>9'8"</b>	<b>9'3"</b>	<b>9'11"</b>	<b>9'11"</b>
Digging depth (§)		mm	124	124	94	124	124	94	124	124	94
		in	<b>4.9</b>	<b>4.9</b>	<b>3.7</b>	<b>4.9</b>	<b>4.9</b>	<b>3.7</b>	<b>4.9</b>	<b>4.9</b>	<b>3.7</b>
Overall length		mm	8592	8817	8817	8604	8829	8829	8691	8916	8916
		ft/in	<b>28'3"</b>	<b>29'0"</b>	<b>29'0"</b>	<b>28'3"</b>	<b>29'0"</b>	<b>29'0"</b>	<b>28'7"</b>	<b>29'4"</b>	<b>29'4"</b>
Overall height with bucket at maximum lift		mm	5788	5788	5788	5902	5902	5902	5902	5902	5902
		ft/in	<b>19'0"</b>	<b>19'0"</b>	<b>19'0"</b>	<b>19'5"</b>	<b>19'5"</b>	<b>19'5"</b>	<b>19'5"</b>	<b>19'5"</b>	<b>19'5"</b>
Loader clearance circle with bucket at carry position (§)		mm	14 727	14 899	14 899	14 733	14 905	14 905	14 778	14 951	14 951
		ft/in	<b>48'4"</b>	<b>48'11"</b>	<b>48'11"</b>	<b>48'5"</b>	<b>48'11"</b>	<b>48'11"</b>	<b>48'6"</b>	<b>49'1"</b>	<b>49'1"</b>
Static tipping load, straight (ISO)*		kg	16 852	16 671	16 870	16 833	16 652	16 885	16 635	16 453	16 693
		lb	<b>37,142</b>	<b>36,743</b>	<b>37,182</b>	<b>37,101</b>	<b>36,701</b>	<b>37,215</b>	<b>36,664</b>	<b>36,262</b>	<b>36,792</b>
Static tipping load, straight (rigid tire)*		kg	18 071	17 886	18 074	18 062	17 877	18 113	17 855	17 669	17 913
		lb	<b>39,829</b>	<b>39,422</b>	<b>39,835</b>	<b>39,809</b>	<b>39,401</b>	<b>39,922</b>	<b>39,353</b>	<b>38,943</b>	<b>39,480</b>
Static tipping load, articulated (ISO)*		kg	14 843	14 661	14 851	14 821	14 638	14 856	14 636	14 452	14 677
		lb	<b>32,715</b>	<b>32,312</b>	<b>32,733</b>	<b>32,666</b>	<b>32,262</b>	<b>32,743</b>	<b>32,259</b>	<b>31,853</b>	<b>32,349</b>
Static tipping load, articulated (rigid tire)*		kg	16 034	15 849	16 028	16 021	15 836	16 056	15 828	15 642	15 869
		lb	<b>35,339</b>	<b>34,932</b>	<b>35,326</b>	<b>35,311</b>	<b>34,903</b>	<b>35,388</b>	<b>34,886</b>	<b>34,476</b>	<b>34,977</b>
Breakout force** (§)		kN	187	185	199	185	183	197	173	171	184
		lbf	<b>42,151</b>	<b>41,781</b>	<b>44,901</b>	<b>41,695</b>	<b>41,326</b>	<b>44,390</b>	<b>38,984</b>	<b>38,618</b>	<b>41,343</b>
Operating weight*		kg	24 081	24 218	24 055	24 133	24 270	24 107	24 189	24 326	24 163
		lb	<b>53,073</b>	<b>53,377</b>	<b>53,017</b>	<b>53,188</b>	<b>53,492</b>	<b>53,132</b>	<b>53,311</b>	<b>53,615</b>	<b>53,255</b>

\*Static tipping loads and operating weights shown are based on a machine configuration with Michelin 26.5R25 XHA2 L3 Radial tires, full fluids, operator, standard counterweight, cold start, roading fenders, Product Link, open differential axles (front/rear), power train guard, secondary steering, and sound suppression.

\*\*Measured 102 mm (4") behind tip of cutting edge with bucket hinge pin as pivot point in accordance with SAE J732C.

(§) Specifications and ratings conform to all applicable standards recommended by the Society of Automotive Engineers, including SAE Standard J732C governing loader ratings.

(ISO) Full compliance to ISO 14397-1 (2007) Sections 1 thru 6, which requires 2% verification between calculations and testing.

(Rigid Tire) Compliance to ISO 14397-1 (2007) Sections 1 thru 5.

**NOTE:** Bucket availability varies by region. Consult your local dealer for availability.



Bucket Type	General Purpose — Pin On			General Purpose — Fusion QC						
	Edge Type	Bolt-on Cutting Edges	Teeth & Segments	Teeth	Bolt-on Cutting Edges	Teeth & Segments	Teeth	Bolt-on Cutting Edges	Teeth & Segments	Teeth
Capacity — rated (§)	m <sup>3</sup>	4.60	4.60	4.40	3.80	3.80	3.60	4.20	4.20	4.00
	yd <sup>3</sup>	<b>6.02</b>	<b>6.02</b>	<b>5.75</b>	<b>4.97</b>	<b>4.97</b>	<b>4.71</b>	<b>5.49</b>	<b>5.49</b>	<b>5.23</b>
Capacity — struck (§)	m <sup>3</sup>	4.05	4.05	3.90	3.24	3.24	3.09	3.80	3.80	3.60
	yd <sup>3</sup>	<b>5.30</b>	<b>5.30</b>	<b>5.10</b>	<b>4.24</b>	<b>4.24</b>	<b>4.04</b>	<b>4.97</b>	<b>4.97</b>	<b>4.71</b>
Width (§)	mm	3220	3271	3271	3220	3271	3271	3220	3271	3271
	ft/in	<b>10'6"</b>	<b>10'8"</b>	<b>10'8"</b>	<b>10'6"</b>	<b>10'8"</b>	<b>10'8"</b>	<b>10'6"</b>	<b>10'8"</b>	<b>10'8"</b>
Dump clearance at maximum lift and 45° discharge (§)	mm	2977	2823	2823	3038	2886	2886	2960	2806	2806
	ft/in	<b>9'9"</b>	<b>9'3"</b>	<b>9'3"</b>	<b>9'11"</b>	<b>9'5"</b>	<b>9'5"</b>	<b>9'8"</b>	<b>9'2"</b>	<b>9'2"</b>
Reach at maximum lift and 45° discharge (§)	mm	1400	1537	1537	1362	1501	1501	1433	1571	1571
	ft/in	<b>4'7"</b>	<b>5'0"</b>	<b>5'0"</b>	<b>4'5"</b>	<b>4'11"</b>	<b>4'11"</b>	<b>4'8"</b>	<b>5'1"</b>	<b>5'1"</b>
Reach at level lift arm and bucket level (§)	mm	2857	3062	3062	2783	2988	2988	2893	3097	3097
	ft/in	<b>9'4"</b>	<b>10'0"</b>	<b>10'0"</b>	<b>9'1"</b>	<b>9'9"</b>	<b>9'9"</b>	<b>9'5"</b>	<b>10'1"</b>	<b>10'1"</b>
Digging depth (§)	mm	124	124	94	124	124	94	116	116	86
	in	<b>4.9</b>	<b>4.9</b>	<b>3.7</b>	<b>4.9</b>	<b>4.9</b>	<b>3.7</b>	<b>4.5</b>	<b>4.5</b>	<b>3.4</b>
Overall length	mm	8710	8935	8935	8637	8862	8862	8739	8965	8965
	ft/in	<b>28'7"</b>	<b>29'4"</b>	<b>29'4"</b>	<b>28'5"</b>	<b>29'1"</b>	<b>29'1"</b>	<b>28'9"</b>	<b>29'5"</b>	<b>29'5"</b>
Overall height with bucket at maximum lift	mm	5874	5874	5874	5803	5803	5803	5960	5960	5960
	ft/in	<b>19'4"</b>	<b>19'4"</b>	<b>19'4"</b>	<b>19'1"</b>	<b>19'1"</b>	<b>19'1"</b>	<b>19'7"</b>	<b>19'7"</b>	<b>19'7"</b>
Loader clearance circle with bucket at carry position (§)	mm	14 787	14 961	14 961	14 743	14 917	14 917	14 794	14 970	14 970
	ft/in	<b>48'7"</b>	<b>49'1"</b>	<b>49'1"</b>	<b>48'5"</b>	<b>49'0"</b>	<b>49'0"</b>	<b>48'7"</b>	<b>49'2"</b>	<b>49'2"</b>
Static tipping load, straight (ISO)*	kg	16 631	16 447	16 792	16 279	16 099	16 440	16 015	15 834	16 167
	lb	<b>36,655</b>	<b>36,249</b>	<b>37,010</b>	<b>35,880</b>	<b>35,483</b>	<b>36,233</b>	<b>35,297</b>	<b>34,898</b>	<b>35,634</b>
Static tipping load, straight (rigid tire)*	kg	17 875	17 687	18 047	17 471	17 287	17 643	17 204	17 020	17 368
	lb	<b>39,397</b>	<b>38,983</b>	<b>39,777</b>	<b>38,506</b>	<b>38,101</b>	<b>38,885</b>	<b>37,918</b>	<b>37,512</b>	<b>38,280</b>
Static tipping load, articulated (ISO)*	kg	14 622	14 436	14 771	14 292	14 111	14 438	14 047	13 865	14 186
	lb	<b>32,227</b>	<b>31,817</b>	<b>32,556</b>	<b>31,501</b>	<b>31,100</b>	<b>31,821</b>	<b>30,961</b>	<b>30,558</b>	<b>31,266</b>
Static tipping load, articulated (rigid tire)*	kg	15 837	15 649	15 997	15 460	15 276	15 616	15 214	15 029	15 363
	lb	<b>34,906</b>	<b>34,492</b>	<b>35,257</b>	<b>34,074</b>	<b>33,670</b>	<b>34,418</b>	<b>33,531</b>	<b>33,125</b>	<b>33,860</b>
Breakout force** (§)	kN	170	168	180	180	179	192	166	164	176
	lbf	<b>38,277</b>	<b>37,912</b>	<b>40,561</b>	<b>40,632</b>	<b>40,264</b>	<b>43,192</b>	<b>37,382</b>	<b>37,023</b>	<b>39,561</b>
Operating weight*	kg	24 229	24 366	24 203	24 498	24 636	24 472	24 561	24 699	24 536
	lb	<b>53,399</b>	<b>53,703</b>	<b>53,343</b>	<b>53,992</b>	<b>54,296</b>	<b>53,936</b>	<b>54,132</b>	<b>54,436</b>	<b>54,076</b>

\*Static tipping loads and operating weights shown are based on a machine configuration with Michelin 26.5R25 XHA2 L3 Radial tires, full fluids, operator, standard counterweight, cold start, roading fenders, Product Link, open differential axles (front/rear), power train guard, secondary steering, and sound suppression.

\*\*Measured 102 mm (4") behind tip of cutting edge with bucket hinge pin as pivot point in accordance with SAE J732C.

(§) Specifications and ratings conform to all applicable standards recommended by the Society of Automotive Engineers, including SAE Standard J732C governing loader ratings.

(ISO) Full compliance to ISO 14397-1 (2007) Sections 1 thru 6, which requires 2% verification between calculations and testing.

(Rigid Tire) Compliance to ISO 14397-1 (2007) Sections 1 thru 5.

**NOTE:** Bucket availability varies by region. Consult your local dealer for availability.

Bucket Type	General Purpose — Fusion QC			Material Handling — Pin On		
	Bolt-on Cutting Edges	Teeth & Segments	Teeth	Bolt-on Cutting Edges	Teeth & Segments	Teeth
Edge Type						
Capacity — rated (§)	m <sup>3</sup> yd <sup>3</sup>	4.60 <b>6.02</b>	4.60 <b>6.02</b>	4.40 <b>5.75</b>	4.20 <b>5.49</b>	4.00 <b>5.23</b>
Capacity — struck (§)	m <sup>3</sup> yd <sup>3</sup>	4.05 <b>5.30</b>	4.05 <b>5.30</b>	3.90 <b>5.10</b>	3.60 <b>4.71</b>	3.45 <b>4.51</b>
Width (§)	mm ft/in	3220 <b>10'6"</b>	3271 <b>10'8"</b>	3271 <b>10'8"</b>	3220 <b>10'6"</b>	3271 <b>10'8"</b>
Dump clearance at maximum lift and 45° discharge (§)	mm ft/in	2947 <b>9'8"</b>	2793 <b>9'1"</b>	2793 <b>9'1"</b>	2967 <b>9'8"</b>	2804 <b>9'2"</b>
Reach at maximum lift and 45° discharge (§)	mm ft/in	1436 <b>4'8"</b>	1573 <b>5'1"</b>	1573 <b>5'1"</b>	1263 <b>4'1"</b>	1390 <b>4'6"</b>
Reach at level lift arm and bucket level (§)	mm ft/in	2903 <b>9'6"</b>	3108 <b>10'2"</b>	3108 <b>10'2"</b>	2784 <b>9'1"</b>	2988 <b>9'9"</b>
Digging depth (§)	mm in	123 <b>4.8</b>	123 <b>4.8</b>	93 <b>3.6</b>	124 <b>4.9</b>	124 <b>4.9</b>
Overall length	mm ft/in	8755 <b>28'9"</b>	8980 <b>29'6"</b>	8980 <b>29'6"</b>	8637 <b>28'5"</b>	8862 <b>29'1"</b>
Overall height with bucket at maximum lift	mm ft/in	6038 <b>19'10"</b>	6038 <b>19'10"</b>	6038 <b>19'10"</b>	5874 <b>19'4"</b>	5874 <b>19'4"</b>
Loader clearance circle with bucket at carry position (§)	mm ft/in	14 804 <b>48'7"</b>	14 981 <b>49'2"</b>	14 981 <b>49'2"</b>	14 750 <b>48'5"</b>	14 922 <b>49'0"</b>
Static tipping load, straight (ISO)*	kg lb	16 131 <b>35,553</b>	15 947 <b>35,148</b>	16 277 <b>35,875</b>	16 598 <b>36,582</b>	16 417 <b>36,185</b>
Static tipping load, straight (rigid tire)*	kg lb	17 364 <b>38,271</b>	17 176 <b>37,857</b>	17 523 <b>38,622</b>	17 794 <b>39,219</b>	17 610 <b>38,814</b>
Static tipping load, articulated (ISO)*	kg lb	14 136 <b>31,156</b>	13 950 <b>30,747</b>	14 268 <b>31,448</b>	14 612 <b>32,205</b>	14 430 <b>31,804</b>
Static tipping load, articulated (rigid tire)*	kg lb	15 344 <b>33,819</b>	15 156 <b>33,405</b>	15 489 <b>34,138</b>	15 782 <b>34,784</b>	15 598 <b>34,379</b>
Breakout force** (§)	kN lbf	164 <b>37,007</b>	163 <b>36,644</b>	174 <b>39,144</b>	180 <b>40,629</b>	179 <b>40,261</b>
Operating weight*	kg lb	24 675 <b>54,383</b>	24 813 <b>54,687</b>	24 650 <b>54,328</b>	24 143 <b>53,210</b>	24 280 <b>53,514</b>

\*Static tipping loads and operating weights shown are based on a machine configuration with Michelin 26.5R25 XHA2 L3 Radial tires, full fluids, operator, standard counterweight, cold start, roading fenders, Product Link, open differential axles (front/rear), power train guard, secondary steering, and sound suppression.

\*\*Measured 102 mm (4") behind tip of cutting edge with bucket hinge pin as pivot point in accordance with SAE J732C.

(§) Specifications and ratings conform to all applicable standards recommended by the Society of Automotive Engineers, including SAE Standard J732C governing loader ratings.

(ISO) Full compliance to ISO 14397-1 (2007) Sections 1 thru 6, which requires 2% verification between calculations and testing.

(Rigid Tire) Compliance to ISO 14397-1 (2007) Sections 1 thru 5.

**NOTE:** Bucket availability varies by region. Consult your local dealer for availability.

Bucket Type	Rock – Pin On***			Coal – Pin On	Coal – Fusion QC	High Lift Change in Specs	
	Edge Type	Bolt-on Cutting Edges	Teeth & Segments	Teeth	Bolt-on Cutting Edges		Bolt-on Cutting Edges
Capacity – rated (\$)	m <sup>3</sup>	3.40	3.40	3.20	7.10	7.10	–
	yd <sup>3</sup>	<b>4.45</b>	<b>4.45</b>	<b>4.19</b>	<b>9.29</b>	<b>9.29</b>	–
Capacity – struck (\$)	m <sup>3</sup>	2.90	2.90	2.70	6.20	6.20	–
	yd <sup>3</sup>	<b>3.79</b>	<b>3.79</b>	<b>3.53</b>	<b>8.11</b>	<b>8.11</b>	–
Width (\$)	mm	3252	3252	3252	3447	3447	–
	ft/in	<b>10'8"</b>	<b>10'8"</b>	<b>10'8"</b>	<b>11'3"</b>	<b>11'3"</b>	–
Dump clearance at maximum lift and 45° discharge (\$)	mm	3124	3026	3026	2625	2597	558
	ft/in	<b>10'2"</b>	<b>9'11"</b>	<b>9'11"</b>	<b>8'7"</b>	<b>8'6"</b>	<b>1'9"</b>
Reach at maximum lift and 45° discharge (\$)	mm	1454	1576	1576	1583	1630	0
	ft/in	<b>4'9"</b>	<b>5'2"</b>	<b>5'2"</b>	<b>5'2"</b>	<b>5'4"</b>	<b>0"</b>
Reach at level lift arm and bucket level (\$)	mm	2818	2974	2974	3252	3305	404
	ft/in	<b>9'2"</b>	<b>9'9"</b>	<b>9'9"</b>	<b>10'8"</b>	<b>10'10"</b>	<b>1'3"</b>
Digging depth (\$)	mm	68	68	25	140	126	–25
	in	<b>2.7</b>	<b>2.7</b>	<b>0.9</b>	<b>5.5</b>	<b>4.9</b>	<b>–1.0</b>
Overall length	mm	8656	8817	8817	9117	9160	788
	ft/in	<b>28'5"</b>	<b>29'0"</b>	<b>29'0"</b>	<b>29'11"</b>	<b>30'1"</b>	<b>2'7"</b>
Overall height with bucket at maximum lift	mm	5845	5845	5845	6071	6311	559
	ft/in	<b>19'3"</b>	<b>19'3"</b>	<b>19'3"</b>	<b>19'11"</b>	<b>20'9"</b>	<b>1'10"</b>
Loader clearance circle with bucket at carry position (\$)	mm	14 813	14 901	14 901	15 214	15 232	481
	ft/in	<b>48'8"</b>	<b>48'11"</b>	<b>48'11"</b>	<b>49'11"</b>	<b>50'0"</b>	<b>1'7"</b>
Static tipping load, straight (ISO)*	kg	17 057	16 988	17 358	15 930	15 134	170
	lb	<b>37,594</b>	<b>37,441</b>	<b>38,257</b>	<b>35,111</b>	<b>33,357</b>	<b>376</b>
Static tipping load, straight (rigid tire)*	kg	18 293	18 222	18 604	17 192	16 375	115
	lb	<b>40,318</b>	<b>40,162</b>	<b>41,003</b>	<b>37,891</b>	<b>36,091</b>	<b>254</b>
Static tipping load, articulated (ISO)*	kg	15 004	14 934	15 298	13 955	13 180	–11
	lb	<b>33,068</b>	<b>32,914</b>	<b>33,717</b>	<b>30,757</b>	<b>29,048</b>	<b>–26</b>
Static tipping load, articulated (rigid tire)*	kg	16 213	16 142	16 515	15 189	14 399	–54
	lb	<b>35,734</b>	<b>35,578</b>	<b>36,400</b>	<b>33,478</b>	<b>31,736</b>	<b>–120</b>
Breakout force** (\$)	kN	186	185	193	129	124	–14
	lbf	<b>41,828</b>	<b>41,704</b>	<b>43,564</b>	<b>29,095</b>	<b>27,969</b>	<b>–3167</b>
Operating weight*	kg	25 011	25 063	24 832	24 496	25 130	1726
	lb	<b>55,125</b>	<b>55,239</b>	<b>54,730</b>	<b>53,989</b>	<b>55,387</b>	<b>3803</b>

\*Static tipping loads and operating weights shown are based on a machine configuration with Michelin 26.5R25 XHA2 L3 Radial tires, full fluids, operator, standard counterweight, cold start, roading fenders, Product Link, open differential axles (front/rear), power train guard, secondary steering, and sound suppression.

\*\*Measured 102 mm (4") behind tip of cutting edge with bucket hinge pin as pivot point in accordance with SAE J732C.

\*\*\*Rock bucket specifications are given on Michelin 26.5R25 XLDD2 L5 Radial tires.

(\$)

Specifications and ratings conform to all applicable standards recommended by the Society of Automotive Engineers, including SAE Standard J732C governing loader ratings.

(ISO) Full compliance to ISO 14397-1 (2007) Sections 1 thru 6, which requires 2% verification between calculations and testing.

(Rigid Tire) Compliance to ISO 14397-1 (2007) Sections 1 thru 5.

**NOTE:** Bucket availability varies by region. Consult your local dealer for availability.

Bucket Type		General Purpose — Pin On									
		Bolt-on Cutting Edges	Teeth & Segments	Teeth	Bolt-on Cutting Edges	Teeth & Segments	Teeth	Bolt-on Cutting Edges	Teeth & Segments	Teeth	
Edge Type											
	Capacity — rated (§)	m <sup>3</sup>	4.20	4.20	4.00	4.40	4.40	4.20	4.60	4.60	4.40
		yd <sup>3</sup>	<b>5.49</b>	<b>5.49</b>	<b>5.23</b>	<b>5.75</b>	<b>5.75</b>	<b>5.49</b>	<b>6.02</b>	<b>6.02</b>	<b>5.75</b>
Capacity — struck (§)		m <sup>3</sup>	3.70	3.70	3.50	3.80	3.80	3.60	4.00	4.00	3.80
		yd <sup>3</sup>	<b>4.84</b>	<b>4.84</b>	<b>4.58</b>	<b>4.97</b>	<b>4.97</b>	<b>4.71</b>	<b>5.23</b>	<b>5.23</b>	<b>4.97</b>
Width (§)		mm	3220	3271	3271	3220	3271	3271	3220	3271	3271
		ft/in	<b>10'6"</b>	<b>10'8"</b>	<b>10'8"</b>	<b>10'6"</b>	<b>10'8"</b>	<b>10'8"</b>	<b>10'6"</b>	<b>10'8"</b>	<b>10'8"</b>
Dump clearance at maximum lift and 45° discharge (§)		mm	3225	3071	3071	3229	3076	3076	3187	3033	3033
		ft/in	<b>10'6"</b>	<b>10'0"</b>	<b>10'0"</b>	<b>10'7"</b>	<b>10'1"</b>	<b>10'1"</b>	<b>10'5"</b>	<b>9'11"</b>	<b>9'11"</b>
Reach at maximum lift and 45° discharge (§)		mm	1332	1470	1470	1327	1465	1465	1363	1500	1500
		ft/in	<b>4'4"</b>	<b>4'9"</b>	<b>4'9"</b>	<b>4'4"</b>	<b>4'9"</b>	<b>4'9"</b>	<b>4'5"</b>	<b>4'11"</b>	<b>4'11"</b>
Reach at level lift arm and bucket level (§)		mm	2955	3160	3160	2948	3153	3153	3004	3209	3209
		ft/in	<b>9'8"</b>	<b>10'4"</b>	<b>10'4"</b>	<b>9'8"</b>	<b>10'4"</b>	<b>10'4"</b>	<b>9'10"</b>	<b>10'6"</b>	<b>10'6"</b>
Digging depth (§)		mm	103	103	73	103	103	73	103	103	73
		in	<b>4.0</b>	<b>4.0</b>	<b>2.8</b>	<b>4.0</b>	<b>4.0</b>	<b>2.8</b>	<b>4.0</b>	<b>4.0</b>	<b>2.8</b>
Overall length		mm	9129	9353	9353	9122	9346	9346	9178	9402	9402
		ft/in	<b>30'0"</b>	<b>30'9"</b>	<b>30'9"</b>	<b>30'0"</b>	<b>30'8"</b>	<b>30'8"</b>	<b>30'2"</b>	<b>30'11"</b>	<b>30'11"</b>
Overall height with bucket at maximum lift		mm	5937	5937	5937	6230	6230	6230	6195	6195	6195
		ft/in	<b>19'6"</b>	<b>19'6"</b>	<b>19'6"</b>	<b>20'6"</b>	<b>20'6"</b>	<b>20'6"</b>	<b>20'4"</b>	<b>20'4"</b>	<b>20'4"</b>
Loader clearance circle with bucket at carry position (§)		mm	14 925	15 104	15 104	14 921	15 100	15 100	14 951	15 132	15 132
		ft/in	<b>49'0"</b>	<b>49'7"</b>	<b>49'7"</b>	<b>49'0"</b>	<b>49'7"</b>	<b>49'7"</b>	<b>49'1"</b>	<b>49'8"</b>	<b>49'8"</b>
Static tipping load, straight (ISO)*		kg	18 770	18 589	18 840	18 817	18 636	18 885	18 658	18 476	18 733
		lb	<b>41,371</b>	<b>40,971</b>	<b>41,523</b>	<b>41,474</b>	<b>41,074</b>	<b>41,622</b>	<b>41,124</b>	<b>40,722</b>	<b>41,288</b>
Static tipping load, straight (rigid tire)*		kg	20 088	19 903	20 157	20 147	19 962	20 215	19 985	19 799	20 059
		lb	<b>44,274</b>	<b>43,866</b>	<b>44,427</b>	<b>44,405</b>	<b>43,996</b>	<b>44,554</b>	<b>44,048</b>	<b>43,638</b>	<b>44,210</b>
Static tipping load, articulated (ISO)*		kg	16 396	16 213	16 447	16 437	16 253	16 485	16 289	16 104	16 343
		lb	<b>36,138</b>	<b>35,734</b>	<b>36,251</b>	<b>36,227</b>	<b>35,822</b>	<b>36,334</b>	<b>35,901</b>	<b>35,494</b>	<b>36,021</b>
Static tipping load, articulated (rigid tire)*		kg	17 706	17 521	17 757	17 758	17 573	17 807	17 608	17 422	17 662
		lb	<b>39,024</b>	<b>38,616</b>	<b>39,138</b>	<b>39,140</b>	<b>38,731</b>	<b>39,248</b>	<b>38,808</b>	<b>38,398</b>	<b>38,927</b>
Breakout force** (§)		kN	210	208	223	211	209	224	202	201	214
		lbf	<b>47,189</b>	<b>46,880</b>	<b>50,138</b>	<b>47,419</b>	<b>47,109</b>	<b>50,397</b>	<b>45,482</b>	<b>45,173</b>	<b>48,227</b>
Operating weight*		kg	26 223	26 361	26 198	26 229	26 367	26 203	26 284	26 422	26 258
		lb	<b>57,795</b>	<b>58,099</b>	<b>57,740</b>	<b>57,807</b>	<b>58,111</b>	<b>57,752</b>	<b>57,929</b>	<b>58,233</b>	<b>57,873</b>

\*Static tipping loads and operating weights shown are based on a machine configuration with Michelin 26.5R25 XHA2 L3 Radial tires, full fluids, operator, standard counterweight, cold start, roading fenders, Product Link, open differential axles (front/rear), power train guard, secondary steering, and sound suppression.

\*\*Measured 102 mm (4") behind tip of cutting edge with bucket hinge pin as pivot point in accordance with SAE J732C.

(§) Specifications and ratings conform to all applicable standards recommended by the Society of Automotive Engineers, including SAE Standard J732C governing loader ratings.

(ISO) Full compliance to ISO 14397-1 (2007) Sections 1 thru 6, which requires 2% verification between calculations and testing.

(Rigid Tire) Compliance to ISO 14397-1 (2007) Sections 1 thru 5.

**NOTE:** Bucket availability varies by region. Consult your local dealer for availability.

# Wheel Loaders Integrated Toolcarriers

## Performance Data ● 972K

Bucket Type		General Purpose — Pin On					General Purpose — Fusion QC			
		Bolt-on Cutting Edges	Teeth & Segments	Teeth	Bolt-on Cutting Edges	Teeth & Segments	Teeth	Bolt-on Cutting Edges	Teeth & Segments	Teeth
Capacity — rated (§)	m <sup>3</sup>	4.80	4.80	4.60	5.00	5.00	4.80	4.20	4.20	4.00
	yd <sup>3</sup>	<b>6.28</b>	<b>6.28</b>	<b>6.02</b>	<b>6.54</b>	<b>6.54</b>	<b>6.28</b>	<b>5.49</b>	<b>5.49</b>	<b>5.23</b>
Capacity — struck (§)	m <sup>3</sup>	4.10	4.10	3.90	4.30	4.30	4.10	3.70	3.70	3.50
	yd <sup>3</sup>	<b>5.36</b>	<b>5.36</b>	<b>5.10</b>	<b>5.62</b>	<b>5.62</b>	<b>5.36</b>	<b>4.84</b>	<b>4.84</b>	<b>4.58</b>
Width (§)	mm	3220	3271	3271	3220	3271	3271	3220	3271	3271
	ft/in	<b>10'6"</b>	<b>10'8"</b>	<b>10'8"</b>	<b>10'6"</b>	<b>10'8"</b>	<b>10'8"</b>	<b>10'6"</b>	<b>10'8"</b>	<b>10'8"</b>
Dump clearance at maximum lift and 45° discharge (§)	mm	3154	2999	2999	3137	2982	2982	3195	3041	3041
	ft/in	<b>10'4"</b>	<b>9'10"</b>	<b>9'10"</b>	<b>10'3"</b>	<b>9'9"</b>	<b>9'9"</b>	<b>10'5"</b>	<b>9'11"</b>	<b>9'11"</b>
Reach at maximum lift and 45° discharge (§)	mm	1392	1528	1528	1407	1543	1543	1367	1504	1504
	ft/in	<b>4'6"</b>	<b>5'0"</b>	<b>5'0"</b>	<b>4'7"</b>	<b>5'0"</b>	<b>5'0"</b>	<b>4'5"</b>	<b>4'11"</b>	<b>4'11"</b>
Reach at level lift arm and bucket level (§)	mm	3049	3254	3254	3072	3277	3277	3000	3205	3205
	ft/in	<b>10'0"</b>	<b>10'8"</b>	<b>10'8"</b>	<b>10'0"</b>	<b>10'9"</b>	<b>10'9"</b>	<b>9'10"</b>	<b>10'6"</b>	<b>10'6"</b>
Digging depth (§)	mm	103	103	73	103	103	73	103	103	73
	in	<b>4.0</b>	<b>4.0</b>	<b>2.8</b>	<b>4.0</b>	<b>4.0</b>	<b>2.8</b>	<b>4.0</b>	<b>4.0</b>	<b>2.8</b>
Overall length	mm	9223	9447	9447	9246	9470	9470	9175	9398	9398
	ft/in	<b>30'4"</b>	<b>31'0"</b>	<b>31'0"</b>	<b>30'4"</b>	<b>31'1"</b>	<b>31'1"</b>	<b>30'2"</b>	<b>30'10"</b>	<b>30'10"</b>
Overall height with bucket at maximum lift	mm	6031	6031	6031	6284	6284	6284	6036	6036	6036
	ft/in	<b>19'10"</b>	<b>19'10"</b>	<b>19'10"</b>	<b>20'8"</b>	<b>20'8"</b>	<b>20'8"</b>	<b>19'10"</b>	<b>19'10"</b>	<b>19'10"</b>
Loader clearance circle with bucket at carry position (§)	mm	14 976	15 157	15 157	14 989	15 170	15 170	14 944	15 126	15 126
	ft/in	<b>49'2"</b>	<b>49'9"</b>	<b>49'9"</b>	<b>49'3"</b>	<b>49'10"</b>	<b>49'10"</b>	<b>49'1"</b>	<b>49'8"</b>	<b>49'8"</b>
Static tipping load, straight (ISO)*	kg	18 683	18 500	20 705	18 779	18 595	18 832	18 260	18 079	18 430
	lb	<b>41,179</b>	<b>40,775</b>	<b>45,634</b>	<b>41,390</b>	<b>40,984</b>	<b>41,507</b>	<b>40,246</b>	<b>39,848</b>	<b>40,621</b>
Static tipping load, straight (rigid tire)*	kg	20 017	19 830	22 448	20 115	19 927	20 166	19 563	19 379	19 746
	lb	<b>44,118</b>	<b>43,705</b>	<b>49,475</b>	<b>44,334</b>	<b>43,919</b>	<b>44,447</b>	<b>43,118</b>	<b>42,711</b>	<b>43,520</b>
Static tipping load, articulated (ISO)*	kg	16 317	16 132	18 062	16 414	16 228	16 449	15 906	15 723	16 058
	lb	<b>35,963</b>	<b>35,554</b>	<b>39,810</b>	<b>36,177</b>	<b>35,767</b>	<b>36,254</b>	<b>35,057</b>	<b>34,653</b>	<b>35,393</b>
Static tipping load, articulated (rigid tire)*	kg	17 642	17 455	19 773	17 739	17 551	17 772	17 205	17 020	17 369
	lb	<b>38,884</b>	<b>38,471</b>	<b>43,580</b>	<b>39,097</b>	<b>38,683</b>	<b>39,171</b>	<b>37,920</b>	<b>37,513</b>	<b>38,282</b>
Breakout force** (§)	kN	196	194	207	198	197	210	203	201	215
	lbf	<b>44,075</b>	<b>43,766</b>	<b>46,655</b>	<b>44,634</b>	<b>44,325</b>	<b>47,205</b>	<b>45,615</b>	<b>45,306</b>	<b>48,375</b>
Operating weight*	kg	26 212	26 350	26 186	26 325	26 463	26 299	26 600	26 738	26 574
	lb	<b>57,770</b>	<b>58,074</b>	<b>57,714</b>	<b>58,019</b>	<b>58,323</b>	<b>57,963</b>	<b>58,625</b>	<b>58,929</b>	<b>58,569</b>

\*Static tipping loads and operating weights shown are based on a machine configuration with Michelin 26.5R25 XHA2 L3 Radial tires, full fluids, operator, standard counterweight, cold start, roading fenders, Product Link, open differential axles (front/rear), power train guard, secondary steering, and sound suppression.

\*\*Measured 102 mm (4") behind tip of cutting edge with bucket hinge pin as pivot point in accordance with SAE J732C.

(§) Specifications and ratings conform to all applicable standards recommended by the Society of Automotive Engineers, including SAE Standard J732C governing loader ratings.

(ISO) Full compliance to ISO 14397-1 (2007) Sections 1 thru 6, which requires 2% verification between calculations and testing.

(Rigid Tire) Compliance to ISO 14397-1 (2007) Sections 1 thru 5.

**NOTE:** Bucket availability varies by region. Consult your local dealer for availability.

Bucket Type		General Purpose — Fusion QC								
		Bolt-on Cutting Edges	Teeth & Segments	Teeth	Bolt-on Cutting Edges	Teeth & Segments	Teeth	Bolt-on Cutting Edges	Teeth & Segments	Teeth
Edge Type										
Capacity — rated (§)	m <sup>3</sup>	4.40	4.40	4.20	4.60	4.60	4.40	4.80	4.80	4.60
	yd <sup>3</sup>	<b>5.75</b>	<b>5.75</b>	<b>5.49</b>	<b>6.02</b>	<b>6.02</b>	<b>5.75</b>	<b>6.28</b>	<b>6.28</b>	<b>6.02</b>
Capacity — struck (§)	m <sup>3</sup>	3.80	3.80	3.60	4.00	4.00	3.80	4.10	4.10	3.90
	yd <sup>3</sup>	<b>4.97</b>	<b>4.97</b>	<b>4.71</b>	<b>5.23</b>	<b>5.23</b>	<b>4.97</b>	<b>5.36</b>	<b>5.36</b>	<b>5.10</b>
Width (§)	mm	3220	3271	3271	3220	3271	3271	3220	3271	3271
	ft/in	<b>10'6"</b>	<b>10'8"</b>	<b>10'8"</b>	<b>10'6"</b>	<b>10'8"</b>	<b>10'8"</b>	<b>10'6"</b>	<b>10'8"</b>	<b>10'8"</b>
Dump clearance at maximum lift and 45° discharge (§)	mm	3200	3047	3047	3157	3003	3003	3130	2975	2975
	ft/in	<b>10'6"</b>	<b>9'11"</b>	<b>9'11"</b>	<b>10'4"</b>	<b>9'10"</b>	<b>9'10"</b>	<b>10'3"</b>	<b>9'9"</b>	<b>9'9"</b>
Reach at maximum lift and 45° discharge (§)	mm	1362	1500	1500	1397	1535	1535	1419	1555	1555
	ft/in	<b>4'5"</b>	<b>4'11"</b>	<b>4'11"</b>	<b>4'7"</b>	<b>5'0"</b>	<b>5'0"</b>	<b>4'7"</b>	<b>5'1"</b>	<b>5'1"</b>
Reach at level lift arm and bucket level (§)	mm	2993	3198	3198	3050	3255	3255	3085	3290	3290
	ft/in	<b>9'9"</b>	<b>10'5"</b>	<b>10'5"</b>	<b>10'0"</b>	<b>10'8"</b>	<b>10'8"</b>	<b>10'1"</b>	<b>10'9"</b>	<b>10'9"</b>
Digging depth (§)	mm	103	103	73	103	103	73	103	103	73
	in	<b>4.0</b>	<b>4.0</b>	<b>2.8</b>	<b>4.0</b>	<b>4.0</b>	<b>2.8</b>	<b>4.0</b>	<b>4.0</b>	<b>2.8</b>
Overall length	mm	9167	9391	9391	9224	9448	9448	9259	9483	9483
	ft/in	<b>30'1"</b>	<b>30'10"</b>	<b>30'10"</b>	<b>30'4"</b>	<b>31'0"</b>	<b>31'0"</b>	<b>30'5"</b>	<b>31'2"</b>	<b>31'2"</b>
Overall height with bucket at maximum lift	mm	6205	6205	6205	6211	6211	6211	6270	6270	6270
	ft/in	<b>20'5"</b>	<b>20'5"</b>	<b>20'5"</b>	<b>20'5"</b>	<b>20'5"</b>	<b>20'5"</b>	<b>20'7"</b>	<b>20'7"</b>	<b>20'7"</b>
Loader clearance circle with bucket at carry position (§)	mm	14 940	15 122	15 122	14 971	15 154	15 154	14 991	15 174	15 174
	ft/in	<b>49'1"</b>	<b>49'8"</b>	<b>49'8"</b>	<b>49'2"</b>	<b>49'9"</b>	<b>49'9"</b>	<b>49'3"</b>	<b>49'10"</b>	<b>49'10"</b>
Static tipping load, straight (ISO)*	kg	18 263	18 082	18 439	18 113	17 931	18 282	18 105	17 922	18 271
	lb	<b>40,252</b>	<b>39,853</b>	<b>40,639</b>	<b>39,921</b>	<b>39,520</b>	<b>40,293</b>	<b>39,903</b>	<b>39,500</b>	<b>40,270</b>
Static tipping load, straight (rigid tire)*	kg	19 578	19 393	19 767	19 425	19 239	19 606	19 423	19 236	19 602
	lb	<b>43,150</b>	<b>42,742</b>	<b>43,566</b>	<b>42,812</b>	<b>42,403</b>	<b>43,212</b>	<b>42,808</b>	<b>42,396</b>	<b>43,203</b>
Static tipping load, articulated (ISO)*	kg	15 902	15 719	16 060	15 761	15 577	15 912	15 754	15 569	15 903
	lb	<b>35,049</b>	<b>34,645</b>	<b>35,396</b>	<b>34,738</b>	<b>34,332</b>	<b>35,072</b>	<b>34,722</b>	<b>34,314</b>	<b>35,051</b>
Static tipping load, articulated (rigid tire)*	kg	17 213	17 028	17 383	17 070	16 884	17 233	17 068	16 881	17 230
	lb	<b>37,937</b>	<b>37,530</b>	<b>38,312</b>	<b>37,622</b>	<b>37,212</b>	<b>37,982</b>	<b>37,619</b>	<b>37,207</b>	<b>37,975</b>
Breakout force** (§)	kN	203	202	216	195	194	207	190	189	201
	lbf	<b>45,788</b>	<b>45,479</b>	<b>48,572</b>	<b>43,941</b>	<b>43,632</b>	<b>46,510</b>	<b>42,897</b>	<b>42,588</b>	<b>45,348</b>
Operating weight*	kg	26 642	26 780	26 616	26 700	26 838	26 675	26 695	26 833	26 670
	lb	<b>58,718</b>	<b>59,022</b>	<b>58,662</b>	<b>58,847</b>	<b>59,151</b>	<b>58,791</b>	<b>58,836</b>	<b>59,140</b>	<b>58,780</b>

\*Static tipping loads and operating weights shown are based on a machine configuration with Michelin 26.5R25 XHA2 L3 Radial tires, full fluids, operator, standard counterweight, cold start, roading fenders, Product Link, open differential axles (front/rear), power train guard, secondary steering, and sound suppression.

\*\*Measured 102 mm (4") behind tip of cutting edge with bucket hinge pin as pivot point in accordance with SAE J732C.

(§) Specifications and ratings conform to all applicable standards recommended by the Society of Automotive Engineers, including SAE Standard J732C governing loader ratings.

(ISO) Full compliance to ISO 14397-1 (2007) Sections 1 thru 6, which requires 2% verification between calculations and testing.

(Rigid Tire) Compliance to ISO 14397-1 (2007) Sections 1 thru 5.

**NOTE:** Bucket availability varies by region. Consult your local dealer for availability.

Bucket Type		General Purpose — Fusion QC			Material Handling — Pin On			Rock — Pin On***		
		Bolt-on Cutting Edges	Teeth & Segments	Teeth	Bolt-on Cutting Edges	Teeth & Segments	Teeth	Bolt-on Cutting Edges	Teeth & Segments	Teeth
Capacity — rated (§)	m <sup>3</sup>	5.00	5.00	4.80	4.60	4.60	4.40	3.60	3.60	3.40
	yd <sup>3</sup>	<b>6.54</b>	<b>6.54</b>	<b>6.28</b>	<b>6.02</b>	<b>6.02</b>	<b>5.75</b>	<b>4.71</b>	<b>4.71</b>	<b>4.45</b>
Capacity — struck (§)	m <sup>3</sup>	4.30	4.30	4.10	3.90	3.90	3.70	3.10	3.10	2.90
	yd <sup>3</sup>	<b>5.62</b>	<b>5.62</b>	<b>5.36</b>	<b>5.10</b>	<b>5.10</b>	<b>4.84</b>	<b>4.05</b>	<b>4.05</b>	<b>3.79</b>
Width (§)	mm	3220	3271	3271	3220	3271	3271	3252	3252	3252
	ft/in	<b>10'6"</b>	<b>10'8"</b>	<b>10'8"</b>	<b>10'6"</b>	<b>10'8"</b>	<b>10'8"</b>	<b>10'8"</b>	<b>10'8"</b>	<b>10'8"</b>
Dump clearance at maximum lift and 45° discharge (§)	mm	3106	2951	2951	3120	2957	2957	3336	3248	3248
	ft/in	<b>10'2"</b>	<b>9'8"</b>	<b>9'8"</b>	<b>10'2"</b>	<b>9'8"</b>	<b>9'8"</b>	<b>10'11"</b>	<b>10'7"</b>	<b>10'7"</b>
Reach at maximum lift and 45° discharge (§)	mm	1440	1576	1576	1286	1413	1413	1420	1528	1528
	ft/in	<b>4'8"</b>	<b>5'2"</b>	<b>5'2"</b>	<b>4'2"</b>	<b>4'7"</b>	<b>4'7"</b>	<b>4'7"</b>	<b>5'0"</b>	<b>5'0"</b>
Reach at level lift arm and bucket level (§)	mm	3117	3322	3322	3014	3219	3219	2964	3104	3104
	ft/in	<b>10'2"</b>	<b>10'10"</b>	<b>10'10"</b>	<b>9'10"</b>	<b>10'6"</b>	<b>10'6"</b>	<b>9'8"</b>	<b>10'2"</b>	<b>10'2"</b>
Digging depth (§)	mm	103	103	73	103	103	73	44	44	4
	in	<b>4.0</b>	<b>4.0</b>	<b>2.8</b>	<b>4.0</b>	<b>4.0</b>	<b>2.8</b>	<b>1.7</b>	<b>1.7</b>	<b>0.1</b>
Overall length	mm	9291	9515	9515	9188	9412	9412	9127	9272	9272
	ft/in	<b>30'6"</b>	<b>31'3"</b>	<b>31'3"</b>	<b>30'2"</b>	<b>30'11"</b>	<b>30'11"</b>	<b>30'0"</b>	<b>30'6"</b>	<b>30'6"</b>
Overall height with bucket at maximum lift	mm	6296	6296	6296	6162	6162	6162	6042	6042	6042
	ft/in	<b>20'8"</b>	<b>20'8"</b>	<b>20'8"</b>	<b>20'3"</b>	<b>20'3"</b>	<b>20'3"</b>	<b>19'10"</b>	<b>19'10"</b>	<b>19'10"</b>
Loader clearance circle with bucket at carry position (§)	mm	15 009	15 193	15 193	14 957	15 137	15 137	14 978	15 061	15 061
	ft/in	<b>49'3"</b>	<b>49'11"</b>	<b>49'11"</b>	<b>49'1"</b>	<b>49'8"</b>	<b>49'8"</b>	<b>49'2"</b>	<b>49'5"</b>	<b>49'5"</b>
Static tipping load, straight (ISO)*	kg	17 986	17 802	18 150	18 595	18 413	18 653	19 302	19 235	19 616
	lb	<b>39,642</b>	<b>39,237</b>	<b>40,003</b>	<b>40,983</b>	<b>40,582</b>	<b>41,111</b>	<b>42,543</b>	<b>42,394</b>	<b>43,234</b>
Static tipping load, straight (rigid tire)*	kg	19 306	19 119	19 483	19 901	19 715	19 958	20 641	20 572	20 963
	lb	<b>42,552</b>	<b>42,138</b>	<b>42,941</b>	<b>43,862</b>	<b>43,453</b>	<b>43,988</b>	<b>45,494</b>	<b>45,342</b>	<b>46,202</b>
Static tipping load, articulated (ISO)*	kg	15 636	15 450	15 783	16 235	16 051	16 274	16 872	16 804	17 167
	lb	<b>34,462</b>	<b>34,052</b>	<b>34,786</b>	<b>35,782</b>	<b>35,376</b>	<b>35,869</b>	<b>37,187</b>	<b>37,036</b>	<b>37,837</b>
Static tipping load, articulated (rigid tire)*	kg	16 953	16 766	17 112	17 534	17 349	17 573	18 203	18 134	18 504
	lb	<b>37,366</b>	<b>36,952</b>	<b>37,716</b>	<b>38,646</b>	<b>38,237</b>	<b>38,732</b>	<b>40,120</b>	<b>39,968</b>	<b>40,783</b>
Breakout force** (§)	kN	186	185	196	201	199	213	222	222	231
	lbf	<b>41,881</b>	<b>41,572</b>	<b>44,224</b>	<b>45,174</b>	<b>44,865</b>	<b>47,882</b>	<b>50,090</b>	<b>49,982</b>	<b>52,114</b>
Operating weight*	kg	26 786	26 924	26 761	26 279	26 417	26 253	26 934	26 985	26 760
	lb	<b>59,036</b>	<b>59,340</b>	<b>58,980</b>	<b>57,918</b>	<b>58,222</b>	<b>57,862</b>	<b>59,361</b>	<b>59,473</b>	<b>58,977</b>

\*Static tipping loads and operating weights shown are based on a machine configuration with Michelin 26.5R25 XHA2 L3 Radial tires, full fluids, operator, standard counterweight, cold start, roading fenders, Product Link, open differential axles (front/rear), power train guard, secondary steering, and sound suppression.

\*\*Measured 102 mm (4") behind tip of cutting edge with bucket hinge pin as pivot point in accordance with SAE J732C.

\*\*\*Rock bucket specifications are given on Michelin 26.5R25 XLDD2 L5 Radial tires.

(§) Specifications and ratings conform to all applicable standards recommended by the Society of Automotive Engineers, including SAE Standard J732C governing loader ratings.

(ISO) Full compliance to ISO 14397-1 (2007) Sections 1 thru 6, which requires 2% verification between calculations and testing.

(Rigid Tire) Compliance to ISO 14397-1 (2007) Sections 1 thru 5.

**NOTE:** Bucket availability varies by region. Consult your local dealer for availability.

Bucket Type	Rock – Pin On***			Rock – Fusion QC***			Coal – Pin On	Coal – Fusion QC	High Lift Change in Specs	
	Edge Type	Bolt-on Cutting Edges	Teeth & Segments	Teeth	Bolt-on Cutting Edges	Teeth & Segments	Teeth	Bolt-on Cutting Edges		Bolt-on Cutting Edges
Capacity – rated (§)	m <sup>3</sup>	4.00	4.00	3.80	3.60	3.60	3.40	7.10	7.10	–
	yd <sup>3</sup>	<b>5.23</b>	<b>5.23</b>	<b>4.97</b>	<b>4.71</b>	<b>4.71</b>	<b>4.45</b>	<b>9.29</b>	<b>9.29</b>	–
Capacity – struck (§)	m <sup>3</sup>	3.50	3.50	3.30	3.10	3.10	2.90	6.20	6.20	–
	yd <sup>3</sup>	<b>4.58</b>	<b>4.58</b>	<b>4.32</b>	<b>4.05</b>	<b>4.05</b>	<b>3.79</b>	<b>8.11</b>	<b>8.11</b>	–
Width (§)	mm	3252	3252	3252	3252	3252	3252	3447	3447	–
	ft/in	<b>10'8"</b>	<b>10'8"</b>	<b>10'8"</b>	<b>10'8"</b>	<b>10'8"</b>	<b>10'8"</b>	<b>11'3"</b>	<b>11'3"</b>	–
Dump clearance at maximum lift and 45° discharge (§)	mm	3233	3142	3142	3310	3222	3222	2842	2819	335
	ft/in	<b>10'7"</b>	<b>10'3"</b>	<b>10'3"</b>	<b>10'10"</b>	<b>10'6"</b>	<b>10'6"</b>	<b>9'3"</b>	<b>9'2"</b>	<b>1'1"</b>
Reach at maximum lift and 45° discharge (§)	mm	1463	1571	1571	1455	1563	1563	1544	1584	23
	ft/in	<b>4'9"</b>	<b>5'1"</b>	<b>5'1"</b>	<b>4'9"</b>	<b>5'1"</b>	<b>5'1"</b>	<b>5'0"</b>	<b>5'2"</b>	<b>1"</b>
Reach at level lift arm and bucket level (§)	mm	3073	3214	3214	3008	3147	3147	3393	3438	273
	ft/in	<b>10'1"</b>	<b>10'6"</b>	<b>10'6"</b>	<b>9'10"</b>	<b>10'3"</b>	<b>10'3"</b>	<b>11'1"</b>	<b>11'3"</b>	<b>10"</b>
Digging depth (§)	mm	44	44	44	44	44	4	117	105	–4
	in	<b>1.7</b>	<b>1.7</b>	<b>1.7</b>	<b>1.7</b>	<b>1.7</b>	<b>0.1</b>	<b>4.6</b>	<b>4.1</b>	<b>–0.1</b>
Overall length	mm	9236	9380	9380	9171	9315	9315	9578	9614	336
	ft/in	<b>30'4"</b>	<b>30'10"</b>	<b>30'10"</b>	<b>30'2"</b>	<b>30'7"</b>	<b>30'7"</b>	<b>31'6"</b>	<b>31'7"</b>	<b>1'2"</b>
Overall height with bucket at maximum lift	mm	6159	6159	6159	6060	6060	6060	6546	6581	336
	ft/in	<b>20'3"</b>	<b>20'3"</b>	<b>20'3"</b>	<b>19'11"</b>	<b>19'11"</b>	<b>19'11"</b>	<b>21'6"</b>	<b>21'8"</b>	<b>1'2"</b>
Loader clearance circle with bucket at carry position (§)	mm	15 039	15 123	15 123	14 996	15 081	15 081	15 385	15 401	332
	ft/in	<b>49'5"</b>	<b>49'8"</b>	<b>49'8"</b>	<b>49'3"</b>	<b>49'6"</b>	<b>49'6"</b>	<b>50'6"</b>	<b>50'7"</b>	<b>1'2"</b>
Static tipping load, straight (ISO)*	kg	19 183	19 114	19 459	18 779	18 710	19 158	17 394	16 779	–1558
	lb	<b>42,281</b>	<b>42,128</b>	<b>42,887</b>	<b>41,390</b>	<b>41,238</b>	<b>42,225</b>	<b>38,337</b>	<b>36,983</b>	<b>–3434</b>
Static tipping load, straight (rigid tire)*	kg	20 544	20 474	20 829	20 105	20 035	20 500	18 728	18 106	–1721
	lb	<b>45,281</b>	<b>45,125</b>	<b>45,907</b>	<b>44,312</b>	<b>44,157</b>	<b>45,184</b>	<b>41,277</b>	<b>39,906</b>	<b>–3794</b>
Static tipping load, articulated (ISO)*	kg	16 744	16 674	17 016	16 368	16 299	16 730	15 072	14 465	–1391
	lb	<b>36,905</b>	<b>36,750</b>	<b>37,503</b>	<b>36,076</b>	<b>35,923</b>	<b>36,873</b>	<b>33,220</b>	<b>31,882</b>	<b>–3066</b>
Static tipping load, articulated (rigid tire)*	kg	18 098	18 027	18 376	17 690	17 620	18 065	16 407	15 797	–1568
	lb	<b>39,889</b>	<b>39,733</b>	<b>40,501</b>	<b>38,990</b>	<b>38,835</b>	<b>39,816</b>	<b>36,161</b>	<b>34,817</b>	<b>–3457</b>
Breakout force** (§)	kN	204	204	212	215	214	223	154	149	–5
	lbf	<b>45,999</b>	<b>45,886</b>	<b>47,764</b>	<b>48,357</b>	<b>48,247</b>	<b>50,268</b>	<b>34,604</b>	<b>33,479</b>	<b>–1327</b>
Operating weight*	kg	27 081	27 132	26 907	27 326	27 378	27 153	26 946	27 506	85
	lb	<b>59,685</b>	<b>59,797</b>	<b>59,301</b>	<b>60,225</b>	<b>60,339</b>	<b>59,844</b>	<b>59,387</b>	<b>60,622</b>	<b>186</b>

\*Static tipping loads and operating weights shown are based on a machine configuration with Michelin 26.5R25 XHA2 L3 Radial tires, full fluids, operator, standard counterweight, cold start, roading fenders, Product Link, open differential axles (front/rear), power train guard, secondary steering, and sound suppression.

\*\*Measured 102 mm (4") behind tip of cutting edge with bucket hinge pin as pivot point in accordance with SAE J732C.

\*\*\*Rock bucket specifications are given on Michelin 26.5R25 XLDD2 L5 Radial tires.

(§) Specifications and ratings conform to all applicable standards recommended by the Society of Automotive Engineers, including SAE Standard J732C governing loader ratings.

(ISO) Full compliance to ISO 14397-1 (2007) Sections 1 thru 6, which requires 2% verification between calculations and testing.

(Rigid Tire) Compliance to ISO 14397-1 (2007) Sections 1 thru 5.

**NOTE:** Bucket availability varies by region. Consult your local dealer for availability.



Bucket Type	General Purpose — Pin On						
	Edge Type	Bolt-on Cutting Edges	Teeth & Segments	Teeth	Bolt-on Cutting Edges	Teeth & Segments	Teeth
Capacity — rated (§)	m <sup>3</sup>	4.60	4.60	4.40	4.90	4.90	4.70
	yd <sup>3</sup>	<b>6.02</b>	<b>6.02</b>	<b>5.75</b>	<b>6.41</b>	<b>6.41</b>	<b>6.15</b>
Capacity — struck (§)	m <sup>3</sup>	4.05	4.05	3.90	4.20	4.20	4.00
	yd <sup>3</sup>	<b>5.30</b>	<b>5.30</b>	<b>5.10</b>	<b>5.49</b>	<b>5.49</b>	<b>5.23</b>
Width (§)	mm	3220	3271	3271	3220	3271	3271
	ft/in	<b>10'6"</b>	<b>10'8"</b>	<b>10'8"</b>	<b>10'6"</b>	<b>10'8"</b>	<b>10'8"</b>
Dump clearance at maximum lift and 45° discharge (§)	mm	2978	2824	2824	2920	2765	2765
	ft/in	<b>9'9"</b>	<b>9'3"</b>	<b>9'3"</b>	<b>9'6"</b>	<b>9'0"</b>	<b>9'0"</b>
Reach at maximum lift and 45° discharge (§)	mm	1400	1537	1537	1448	1584	1584
	ft/in	<b>4'7"</b>	<b>5'0"</b>	<b>5'0"</b>	<b>4'9"</b>	<b>5'2"</b>	<b>5'2"</b>
Reach at level lift arm and bucket level (§)	mm	2857	3062	3062	2933	3138	3138
	ft/in	<b>9'4"</b>	<b>10'0"</b>	<b>10'0"</b>	<b>9'7"</b>	<b>10'3"</b>	<b>10'3"</b>
Digging depth (§)	mm	123	123	93	123	123	93
	in	<b>4.8</b>	<b>4.8</b>	<b>3.6</b>	<b>4.8</b>	<b>4.8</b>	<b>3.6</b>
Overall length	mm	8996	9221	9221	9072	9297	9297
	ft/in	<b>29'7"</b>	<b>30'4"</b>	<b>30'4"</b>	<b>29'10"</b>	<b>30'7"</b>	<b>30'7"</b>
Overall height with bucket at maximum lift	mm	5875	5875	5875	6095	6095	6095
	ft/in	<b>19'4"</b>	<b>19'4"</b>	<b>19'4"</b>	<b>20'0"</b>	<b>20'0"</b>	<b>20'0"</b>
Loader clearance circle with bucket at carry position (§)	mm	14 787	14 961	14 961	14 827	15 001	15 001
	ft/in	<b>48'7"</b>	<b>49'1"</b>	<b>49'1"</b>	<b>48'8"</b>	<b>49'3"</b>	<b>49'3"</b>
Static tipping load, straight (ISO)*	kg	20 204	20 021	20 388	20 052	19 867	20 098
	lb	<b>44,531</b>	<b>44,127</b>	<b>44,936</b>	<b>44,194</b>	<b>43,787</b>	<b>44,296</b>
Static tipping load, straight (rigid tire)*	kg	21 762	21 574	21 959	21 624	21 434	21 667
	lb	<b>47,964</b>	<b>47,549</b>	<b>48,397</b>	<b>47,660</b>	<b>47,241</b>	<b>47,755</b>
Static tipping load, articulated (ISO)*	kg	17 668	17 482	17 836	17 520	17 333	17 546
	lb	<b>38,940</b>	<b>38,531</b>	<b>39,312</b>	<b>38,615</b>	<b>38,202</b>	<b>38,672</b>
Static tipping load, articulated (rigid tire)*	kg	19 203	19 015	19 384	19 071	18 881	19 094
	lb	<b>42,325</b>	<b>41,910</b>	<b>42,722</b>	<b>42,032</b>	<b>41,614</b>	<b>42,085</b>
Breakout force** (§)	kN	215	214	228	204	202	215
	lbf	<b>48,470</b>	<b>48,095</b>	<b>51,358</b>	<b>45,923</b>	<b>45,550</b>	<b>48,516</b>
Operating weight*	kg	26 062	26 200	26 037	26 185	26 323	26 160
	lb	<b>57,440</b>	<b>57,744</b>	<b>57,384</b>	<b>57,712</b>	<b>58,016</b>	<b>57,656</b>

\*Static tipping loads and operating weights shown are based on a machine configuration with Michelin 26.5R25 XHA2 L3 Radial tires, full fluids, operator, standard counterweight, cold start, roading fenders, Product Link, open differential axles (front/rear), power train guard, secondary steering, and sound suppression.

\*\*Measured 102 mm (4") behind tip of cutting edge with bucket hinge pin as pivot point in accordance with SAE J732C.

(§) Specifications and ratings conform to all applicable standards recommended by the Society of Automotive Engineers, including SAE Standard J732C governing loader ratings.

(ISO) Full compliance to ISO 14397-1 (2007) Sections 1 thru 6, which requires 2% verification between calculations and testing.

(Rigid Tire) Compliance to ISO 14397-1 (2007) Sections 1 thru 5.

**NOTE:** Bucket availability varies by region. Consult your local dealer for availability.

Bucket Type	General Purpose — Fusion QC						
	Edge Type	Bolt-on Cutting Edges	Teeth & Segments	Teeth	Bolt-on Cutting Edges	Teeth & Segments	Teeth
Capacity — rated (§)	m <sup>3</sup>	4.60	4.60	4.40	4.90	4.90	4.70
	yd <sup>3</sup>	<b>6.02</b>	<b>6.02</b>	<b>5.75</b>	<b>6.41</b>	<b>6.41</b>	<b>6.15</b>
Capacity — struck (§)	m <sup>3</sup>	4.05	4.05	3.90	4.20	4.20	4.00
	yd <sup>3</sup>	<b>5.30</b>	<b>5.30</b>	<b>5.10</b>	<b>5.49</b>	<b>5.49</b>	<b>5.23</b>
Width (§)	mm	3220	3271	3271	3220	3271	3271
	ft/in	<b>10'6"</b>	<b>10'8"</b>	<b>10'8"</b>	<b>10'6"</b>	<b>10'8"</b>	<b>10'8"</b>
Dump clearance at maximum lift and 45° discharge (§)	mm	2948	2794	2794	2899	2744	2744
	ft/in	<b>9'8"</b>	<b>9'2"</b>	<b>9'2"</b>	<b>9'6"</b>	<b>9'0"</b>	<b>9'0"</b>
Reach at maximum lift and 45° discharge (§)	mm	1436	1573	1573	1484	1621	1621
	ft/in	<b>4'8"</b>	<b>5'1"</b>	<b>5'1"</b>	<b>4'10"</b>	<b>5'3"</b>	<b>5'3"</b>
Reach at level lift arm and bucket level (§)	mm	2903	3108	3108	2975	3180	3180
	ft/in	<b>9'6"</b>	<b>10'2"</b>	<b>10'2"</b>	<b>9'9"</b>	<b>10'5"</b>	<b>10'5"</b>
Digging depth (§)	mm	122	122	92	115	115	85
	in	<b>4.8</b>	<b>4.8</b>	<b>3.6</b>	<b>4.5</b>	<b>4.5</b>	<b>3.3</b>
Overall length	mm	9041	9267	9267	9108	9333	9333
	ft/in	<b>29'8"</b>	<b>30'5"</b>	<b>30'5"</b>	<b>29'11"</b>	<b>30'8"</b>	<b>30'8"</b>
Overall height with bucket at maximum lift	mm	6039	6039	6039	6126	6126	6126
	ft/in	<b>19'10"</b>	<b>19'10"</b>	<b>19'10"</b>	<b>20'2"</b>	<b>20'2"</b>	<b>20'2"</b>
Loader clearance circle with bucket at carry position (§)	mm	14 804	14 981	14 981	14 837	15 015	15 015
	ft/in	<b>48'7"</b>	<b>49'2"</b>	<b>49'2"</b>	<b>48'9"</b>	<b>49'4"</b>	<b>49'4"</b>
Static tipping load, straight (ISO)*	kg	19 674	19 491	19 844	19 574	19 389	19 752
	lb	<b>43,362</b>	<b>42,959</b>	<b>43,738</b>	<b>43,141</b>	<b>42,734</b>	<b>43,534</b>
Static tipping load, straight (rigid tire)*	kg	21 217	21 029	21 404	21 141	20 952	21 335
	lb	<b>46,763</b>	<b>46,350</b>	<b>47,176</b>	<b>46,596</b>	<b>46,178</b>	<b>47,023</b>
Static tipping load, articulated (ISO)*	kg	17 155	16 969	17 308	17 052	16 865	17 213
	lb	<b>37,809</b>	<b>37,400</b>	<b>38,147</b>	<b>37,584</b>	<b>37,171</b>	<b>37,937</b>
Static tipping load, articulated (rigid tire)*	kg	18 681	18 493	18 850	18 603	18 413	18 777
	lb	<b>41,173</b>	<b>40,759</b>	<b>41,545</b>	<b>41,001</b>	<b>40,583</b>	<b>41,385</b>
Breakout force** (§)	kN	208	207	220	198	196	209
	lbf	<b>46,886</b>	<b>46,513</b>	<b>49,589</b>	<b>44,570</b>	<b>44,204</b>	<b>47,022</b>
Operating weight*	kg	26 508	26 646	26 483	26 598	26 736	26 573
	lb	<b>58,424</b>	<b>58,728</b>	<b>58,368</b>	<b>58,622</b>	<b>58,926</b>	<b>58,567</b>

\*Static tipping loads and operating weights shown are based on a machine configuration with Michelin 26.5R25 XHA2 L3 Radial tires, full fluids, operator, standard counterweight, cold start, roading fenders, Product Link, open differential axles (front/rear), power train guard, secondary steering, and sound suppression.

\*\*Measured 102 mm (4") behind tip of cutting edge with bucket hinge pin as pivot point in accordance with SAE J732C.

(§) Specifications and ratings conform to all applicable standards recommended by the Society of Automotive Engineers, including SAE Standard J732C governing loader ratings.

(ISO) Full compliance to ISO 14397-1 (2007) Sections 1 thru 6, which requires 2% verification between calculations and testing.

(Rigid Tire) Compliance to ISO 14397-1 (2007) Sections 1 thru 5.

**NOTE:** Bucket availability varies by region. Consult your local dealer for availability.

# Wheel Loaders Integrated Toolcarriers

## Performance Data ● 980K

Bucket Type	General Purpose – Pin On			Rock – Pin On***			Coal – Pin On	High Lift Change in Specs	
	Edge Type	Bolt-on Cutting Edges	Teeth & Segments	Teeth	Bolt-on Cutting Edges	Teeth & Segments	Teeth		Bolt-on Cutting Edges
Capacity – rated (\$)	m <sup>3</sup>	5.40	5.40	5.00	4.40	4.40	4.30	8.20	—
	yd <sup>3</sup>	<b>7.06</b>	<b>7.06</b>	<b>6.54</b>	<b>5.75</b>	<b>5.75</b>	<b>5.62</b>	<b>10.73</b>	—
Capacity – struck (\$)	m <sup>3</sup>	5.00	5.00	4.60	3.21	3.20	3.10	6.47	—
	yd <sup>3</sup>	<b>6.54</b>	<b>6.54</b>	<b>6.02</b>	<b>4.20</b>	<b>4.19</b>	<b>4.05</b>	<b>8.46</b>	—
Width (\$)	mm	3447	3535	3535	3504	3504	3504	3638	—
	ft/in	<b>11'3"</b>	<b>11'7"</b>	<b>11'7"</b>	<b>11'5"</b>	<b>11'5"</b>	<b>11'5"</b>	<b>11'11"</b>	—
Dump clearance at maximum lift and 45° discharge (\$)	mm	3273	3107	3107	3101	3101	3101	2917	220
	ft/in	<b>10'8"</b>	<b>10'2"</b>	<b>10'2"</b>	<b>10'2"</b>	<b>10'2"</b>	<b>10'2"</b>	<b>9'6"</b>	<b>8"</b>
Reach at maximum lift and 45° discharge (\$)	mm	1556	1693	1693	1844	1844	1844	1700	0
	ft/in	<b>5'1"</b>	<b>5'6"</b>	<b>5'6"</b>	<b>6'0"</b>	<b>6'0"</b>	<b>6'0"</b>	<b>5'6"</b>	<b>0"</b>
Reach at level lift arm and bucket level (\$)	mm	3040	3252	3252	3360	3360	3360	3411	160
	ft/in	<b>9'11"</b>	<b>10'8"</b>	<b>10'8"</b>	<b>11'0"</b>	<b>11'0"</b>	<b>11'0"</b>	<b>11'2"</b>	<b>6"</b>
Digging depth (\$)	mm	103	103	68	106	106	71	108	0
	in	<b>4.0</b>	<b>4.0</b>	<b>2.6</b>	<b>4.1</b>	<b>4.1</b>	<b>2.8</b>	<b>4.2</b>	<b>0</b>
Overall length	mm	9509	9750	9750	9844	9844	9844	9883	201
	ft/in	<b>31'3"</b>	<b>32'0"</b>	<b>32'0"</b>	<b>32'4"</b>	<b>32'4"</b>	<b>32'4"</b>	<b>32'6"</b>	<b>8"</b>
Overall height with bucket at maximum lift	mm	6421	6421	6421	6184	6184	6184	6536	221
	ft/in	<b>21'1"</b>	<b>21'1"</b>	<b>21'1"</b>	<b>20'4"</b>	<b>20'4"</b>	<b>20'4"</b>	<b>21'6"</b>	<b>9"</b>
Loader clearance circle with bucket at carry position (\$)	mm	15 853	16 076	16 076	16 094	16 093	16 093	16 234	175
	ft/in	<b>52'1"</b>	<b>52'9"</b>	<b>52'9"</b>	<b>52'10"</b>	<b>52'10"</b>	<b>52'10"</b>	<b>53'4"</b>	<b>7"</b>
Static tipping load, straight (ISO)*	kg	21 822	21 637	22 066	22 141	22 178	22 640	20 819	-1831
	lb	<b>48,096</b>	<b>47,689</b>	<b>48,635</b>	<b>48,799</b>	<b>48,880</b>	<b>49,900</b>	<b>45,887</b>	<b>-4036</b>
Static tipping load, straight (rigid tire)*	kg	23 185	22 999	23 445	23 508	23 554	24 027	22 238	-2026
	lb	<b>51,101</b>	<b>50,691</b>	<b>51,673</b>	<b>51,812</b>	<b>51,915</b>	<b>52,955</b>	<b>49,012</b>	<b>-4467</b>
Static tipping load, articulated (ISO)*	kg	19 267	19 082	19 489	19 536	19 555	20 010	18 293	-1656
	lb	<b>42,464</b>	<b>42,058</b>	<b>42,953</b>	<b>43,057</b>	<b>43,100</b>	<b>44,103</b>	<b>40,318</b>	<b>-3651</b>
Static tipping load, articulated (rigid tire)*	kg	20 484	20 298	20 719	20 754	20 782	21 246	19 567	-1836
	lb	<b>45,148</b>	<b>44,738</b>	<b>45,666</b>	<b>45,742</b>	<b>45,804</b>	<b>46,826</b>	<b>43,125</b>	<b>-4048</b>
Breakout force** (\$)	kN	238	235	254	223	222	241	186	3
	lbf	<b>53,548</b>	<b>52,996</b>	<b>57,101</b>	<b>50,282</b>	<b>50,093</b>	<b>54,147</b>	<b>41,956</b>	<b>813</b>
Operating weight*	kg	31 244	31 383	31 207	31 767	31 842	31 547	31 831	115
	lb	<b>68,862</b>	<b>69,167</b>	<b>68,780</b>	<b>70,013</b>	<b>70,178</b>	<b>69,528</b>	<b>70,156</b>	<b>253</b>

\*Static tipping loads and operating weights shown are based on a machine configuration with Michelin 29.5R25 XLDD1 L4 Radial tires, full fluids, operator, standard counterweight, standard transmission, cold start, roading fenders, Product Link, open differential axles (front/rear), power train guard, secondary steering, and sound suppression.

\*\*Measured 102 mm (4") behind tip of cutting edge with bucket hinge pin as pivot point in accordance with SAE J732C.

\*\*\*Rock bucket specifications are given on Michelin 29.5R25 XLDD2 L5 Radial tires.

(§) Specifications and ratings conform to all applicable standards recommended by the Society of Automotive Engineers, including SAE Standard J732C governing loader ratings.

(ISO) Full compliance to ISO 14397-1 (2007) Sections 1 thru 6, which requires 2% verification between calculations and testing.

(Rigid Tire) Compliance to ISO 14397-1 (2007) Sections 1 thru 5.

**NOTE:** Bucket availability varies by region. Consult your local dealer for availability.

Bucket Type	General Purpose – Pin On						Material Handling – Pin On			
		Bolt-on Cutting Edges	Teeth & Segments	Teeth	Bolt-on Cutting Edges	Teeth & Segments	Teeth	Bolt-on Cutting Edges	Teeth & Segments	Teeth
Edge Type										
Capacity – rated (§)	m <sup>3</sup>	5.70	5.70	5.30	6.00	6.00	5.80	5.70	5.70	5.50
	yd <sup>3</sup>	<b>7.46</b>	<b>7.46</b>	<b>6.93</b>	<b>7.85</b>	<b>7.85</b>	<b>7.59</b>	<b>7.46</b>	<b>7.46</b>	<b>7.19</b>
Capacity – struck (§)	m <sup>3</sup>	4.50	4.50	4.30	5.30	5.30	5.10	5.06	5.06	4.86
	yd <sup>3</sup>	<b>5.89</b>	<b>5.89</b>	<b>5.62</b>	<b>6.93</b>	<b>6.93</b>	<b>6.67</b>	<b>6.62</b>	<b>6.62</b>	<b>6.36</b>
Width (§)	mm	3447	3535	3535	3447	3535	3535	3447	3535	3535
	ft/in	<b>11'3"</b>	<b>11'7"</b>	<b>11'7"</b>	<b>11'3"</b>	<b>11'7"</b>	<b>11'7"</b>	<b>11'3"</b>	<b>11'7"</b>	<b>11'7"</b>
Dump clearance at maximum lift and 45° discharge (§)	mm	3204	3037	3037	3187	3019	3019	3105	2928	2928
	ft/in	<b>10'6"</b>	<b>9'11"</b>	<b>9'11"</b>	<b>10'5"</b>	<b>9'10"</b>	<b>9'10"</b>	<b>10'2"</b>	<b>9'7"</b>	<b>9'7"</b>
Reach at maximum lift and 45° discharge (§)	mm	1604	1738	1738	1625	1760	1760	1519	1641	1641
	ft/in	<b>5'3"</b>	<b>5'8"</b>	<b>5'8"</b>	<b>5'4"</b>	<b>5'9"</b>	<b>5'9"</b>	<b>4'11"</b>	<b>5'4"</b>	<b>5'4"</b>
Reach at level lift arm and bucket level (§)	mm	3124	3336	3336	3152	3364	3364	3149	3361	3361
	ft/in	<b>10'3"</b>	<b>10'11"</b>	<b>10'11"</b>	<b>10'4"</b>	<b>11'0"</b>	<b>11'0"</b>	<b>10'4"</b>	<b>11'0"</b>	<b>11'0"</b>
Digging depth (§)	mm	103	103	68	103	103	68	103	103	68
	in	<b>4.0</b>	<b>4.0</b>	<b>2.6</b>	<b>4.0</b>	<b>4.0</b>	<b>2.6</b>	<b>4.0</b>	<b>4.0</b>	<b>2.6</b>
Overall length	mm	9593	9834	9834	9621	9862	9862	9618	9859	9859
	ft/in	<b>31'6"</b>	<b>32'4"</b>	<b>32'4"</b>	<b>31'7"</b>	<b>32'5"</b>	<b>32'5"</b>	<b>31'7"</b>	<b>32'5"</b>	<b>32'5"</b>
Overall height with bucket at maximum lift	mm	6243	6243	6243	6269	6269	6269	6242	6242	6242
	ft/in	<b>20'6"</b>	<b>20'6"</b>	<b>20'6"</b>	<b>20'7"</b>	<b>20'7"</b>	<b>20'7"</b>	<b>20'6"</b>	<b>20'6"</b>	<b>20'6"</b>
Loader clearance circle with bucket at carry position (§)	mm	15 898	16 123	16 123	15 913	16 138	16 138	15 911	16 137	16 137
	ft/in	<b>52'2"</b>	<b>52'11"</b>	<b>52'11"</b>	<b>52'3"</b>	<b>53'0"</b>	<b>53'0"</b>	<b>52'3"</b>	<b>53'0"</b>	<b>53'0"</b>
Static tipping load, straight (ISO)*	kg	23 011	22 826	23 262	22 869	22 683	23 116	22 514	22 331	22 749
	lb	<b>50,717</b>	<b>50,308</b>	<b>51,271</b>	<b>50,404</b>	<b>49,994</b>	<b>50,949</b>	<b>49,621</b>	<b>49,217</b>	<b>50,139</b>
Static tipping load, straight (rigid tire)*	kg	24 485	24 298	24 753	24 346	24 158	24 609	23 945	23 760	24 194
	lb	<b>53,967</b>	<b>53,554</b>	<b>54,557</b>	<b>53,659</b>	<b>53,245</b>	<b>54,239</b>	<b>52,774</b>	<b>52,367</b>	<b>53,325</b>
Static tipping load, articulated (ISO)*	kg	20 261	20 075	20 489	20 123	19 937	20 347	19 810	19 627	20 024
	lb	<b>44,656</b>	<b>44,247</b>	<b>45,158</b>	<b>44,353</b>	<b>43,943</b>	<b>44,846</b>	<b>43,662</b>	<b>43,258</b>	<b>44,132</b>
Static tipping load, articulated (rigid tire)*	kg	21 597	21 409	21 839	21 462	21 274	21 700	21 106	20 921	21 332
	lb	<b>47,600</b>	<b>47,186</b>	<b>48,133</b>	<b>47,302</b>	<b>46,888</b>	<b>47,827</b>	<b>46,519</b>	<b>46,111</b>	<b>47,017</b>
Breakout force** (§)	kN	224	222	239	220	218	234	221	218	234
	lbf	<b>50,542</b>	<b>50,003</b>	<b>53,707</b>	<b>49,551</b>	<b>49,016</b>	<b>52,596</b>	<b>49,662</b>	<b>49,126</b>	<b>52,720</b>
Operating weight*	kg	32 020	32 159	31 983	32 116	32 255	32 079	32 145	32 284	32 108
	lb	<b>70,572</b>	<b>70,877</b>	<b>70,490</b>	<b>70,784</b>	<b>71,089</b>	<b>70,702</b>	<b>70,848</b>	<b>71,153</b>	<b>70,766</b>

\*Static tipping loads and operating weights shown are based on a machine configuration with Michelin 29.5R25 XLDD1 L4 Radial tires, full fluids, operator, standard counterweight, standard transmission, cold start, roading fenders, Product Link, open differential axles (front/rear), power train guard, secondary steering, and sound suppression.

\*\*Measured 102 mm (4") behind tip of cutting edge with bucket hinge pin as pivot point in accordance with SAE J732C.

(§) Specifications and ratings conform to all applicable standards recommended by the Society of Automotive Engineers, including SAE Standard J732C governing loader ratings.

(ISO) Full compliance to ISO 14397-1 (2007) Sections 1 thru 6, which requires 2% verification between calculations and testing.

(Rigid Tire) Compliance to ISO 14397-1 (2007) Sections 1 thru 5.

**NOTE:** Bucket availability varies by region. Consult your local dealer for availability.

Bucket Type	General Purpose — Pin On									
	Bolt-on Cutting Edges	Teeth & Segments	Teeth	Bolt-on Cutting Edges	Teeth & Segments	Teeth	Bolt-on Cutting Edges	Teeth & Segments	Teeth	
Edge Type										
Capacity — rated	m <sup>3</sup>	2.70	2.70	2.50	3.10	3.10	2.90	3.30	3.30	3.10
Capacity — 110% rated	m <sup>3</sup>	2.97	2.97	2.75	3.41	3.41	3.19	3.63	3.63	3.41
Width	mm	2927	2994	2994	2927	2994	2994	2927	2994	2994
Dump clearance at maximum lift and 45° discharge	mm	3130	3015	3015	3050	2933	2933	3012	2893	2893
Reach at maximum lift and 45° discharge	mm	1212	1326	1326	1262	1374	1374	1292	1403	1403
Reach at level lift arm and bucket level	mm	2626	2787	2787	2720	2881	2881	2770	2931	2931
Digging depth	mm	86	86	56	86	86	56	86	86	56
Overall length	mm	8138	8312	8312	8238	8412	8412	8288	8462	8462
Overall height with bucket at maximum lift	mm	5557	5557	5557	5519	5519	5519	5693	5693	5693
Loader clearance circle with bucket at carry position	mm	13 764	13 928	13 928	13 819	13 984	13 984	13 847	14 013	14 013
Static tipping load, straight with tire squash*	kg	11 924	11 787	12 106	12 178	12 040	12 365	12 082	11 943	12 266
Static tipping load, straight without tire squash*	kg	12 582	12 444	12 773	12 854	12 714	13 050	12 759	12 619	12 952
Static tipping load, articulated with tire squash*	kg	10 408	10 271	10 576	10 594	10 455	10 764	10 503	10 363	10 671
Static tipping load, articulated without tire squash*	kg	11 053	10 915	11 228	11 286	11 147	11 466	11 197	11 057	11 374
Breakout force	kN	168	166	184	154	152	167	147	146	160
Operating weight*	kg	17 903	18 011	17 854	18 631	18 739	18 582	18 676	18 784	18 627
Reach @ 2134 mm height, 45° dumped	mm	1908	1970	1970	1923	1978	1978	1935	1986	1986
Clearance at full raise and dump (on stops)	mm	3028	2897	2897	2954	2823	2823	2917	2786	2786
Dump angle at full raise and dump (on stops)	degrees	53	53	53	52	52	52	52	52	52

\*Static tipping loads and operating weights shown are based on standard machine configuration with 26.5R25 L3Triangle TB516 radial tires, full fuel tank, coolants, lubricants, air conditioner and operator.

**NOTE:** Machine and bucket availability varies by region. Consult your local dealer for availability.

Bucket Type	General Purpose — Pin On						
	Edge Type	Bolt-on Cutting Edges	Teeth & Segments	Teeth	Bolt-on Cutting Edges	Teeth & Segments	Teeth
Capacity — rated	m <sup>3</sup>	3.40	3.40	3.20	3.60	3.60	3.40
Capacity — 110% rated	m <sup>3</sup>	3.74	3.74	3.52	3.96	3.96	3.74
Width	mm	2927	2994	2994	2927	2994	2994
Dump clearance at maximum lift and 45° discharge	mm	2985	2867	2867	2939	2820	2820
Reach at maximum lift and 45° discharge	mm	1314	1425	1425	1351	1460	1460
Reach at level lift arm and bucket level	mm	2805	2966	2966	2865	3026	3026
Digging depth	mm	86	86	56	86	86	56
Overall length	mm	8323	8497	8497	8383	8557	8557
Overall height with bucket at maximum lift	mm	5723	5723	5723	5781	5781	5781
Loader clearance circle with bucket at carry position	mm	13 867	14 034	14 034	13 902	14 069	14 069
Static tipping load, straight with tire squash*	kg	12 020	11 880	12 198	11 904	11 763	12 084
Static tipping load, straight without tire squash*	kg	12 699	12 558	12 885	12 584	12 442	12 774
Static tipping load, articulated with tire squash*	kg	10 444	10 304	10 607	10 333	10 193	10 499
Static tipping load, articulated without tire squash*	kg	11 140	10 998	11 311	11 031	10 889	11 205
Breakout force	kN	143	142	155	137	135	147
Operating weight*	kg	18 706	18 814	18 657	18 764	18 872	18 715
Reach @ 2134 mm height, 45° dumped	mm	1945	1994	1994	1958	2003	2003
Clearance at full raise and dump (on stops)	mm	2891	2760	2760	2846	2716	2716
Dump angle at full raise and dump (on stops)	degrees	52	52	52	51	51	51

\*Static tipping loads and operating weights shown are based on standard machine configuration with 26.5R25 L3 Triangle TB516 radial tires, full fuel tank, coolants, lubricants, air conditioner and operator.

**NOTE:** Machine and bucket availability varies by region. Consult your local dealer for availability.

Bucket Type	General Purpose – Hook On			Material Handling – Pin On	
	Bolt-on Cutting Edges	Teeth & Segments	Teeth	Bolt-on Cutting Edges	
<b>Edge Type</b>					
Capacity – rated	<b>m<sup>3</sup></b>	3.10	3.10	2.90	4.4
Capacity – 110% rated	<b>m<sup>3</sup></b>	3.41	3.41	3.19	4.84
Width	<b>mm</b>	2927	2994	2994	3059
Dump clearance at maximum lift and 45° discharge	<b>mm</b>	3008	2891	2891	2782
Reach at maximum lift and 45° discharge	<b>mm</b>	1299	1410	1410	1362
Reach at level lift arm and bucket level	<b>mm</b>	2775	2936	2936	3002
Digging depth	<b>mm</b>	94	94	64	102
Overall length	<b>mm</b>	8299	8473	8473	8527
Overall height with bucket at maximum lift	<b>mm</b>	5662	5662	5662	5910
Loader clearance circle with bucket at carry position	<b>mm</b>	13 850	14 017	14 017	14 110
Static tipping load, straight with tire squash*	<b>kg</b>	11 577	11 439	11 755	11 184
Static tipping load, straight without tire squash*	<b>kg</b>	12 240	12 101	12 427	11 664
Static tipping load, articulated with tire squash*	<b>kg</b>	10 016	9878	10 179	9641
Static tipping load, articulated without tire squash*	<b>kg</b>	10 697	10 557	10 868	10 186
Breakout force	<b>kN</b>	146	145	159	123
Operating weight*	<b>kg</b>	19 109	19 217	19 060	18 330
Reach @ 2134 mm height, 45° dumped	<b>mm</b>	1940	1993	1993	1883
Clearance at full raise and dump (on stops)	<b>mm</b>	2907	2777	2777	2739
Dump angle at full raise and dump (on stops)	<b>degrees</b>	52	52	52	47.7

\*Static tipping loads and operating weights shown are based on standard machine configuration with 26.5R25 L3 Triangle TB516 radial tires, full fuel tank, coolants, lubricants, air conditioner and operator. Hook On Bucket includes Quick Coupler.

**NOTE:** Machine and bucket availability varies by region. Consult your local dealer for availability.

Bucket Type		General Purpose – Pin On						High Lift Change in Specs	
		Bolt-on Cutting Edges	Teeth & Segments	Bolt-on Cutting Edges	Teeth & Segments	Bolt-on Cutting Edges	Teeth & Segments		
Edge Type	Capacity – rated (§)	m <sup>3</sup>	2.70	2.70	3.10	3.10	3.40	3.40	—
		yd <sup>3</sup>	<b>3.53</b>	<b>3.53</b>	<b>4.05</b>	<b>4.05</b>	<b>4.45</b>	<b>4.45</b>	—
Capacity – rated @ 110% fill factor		m <sup>3</sup>	3.00	3.00	3.40	3.40	3.70	3.70	—
		yd <sup>3</sup>	<b>3.90</b>	<b>3.90</b>	<b>4.50</b>	<b>4.50</b>	<b>4.90</b>	<b>4.90</b>	—
Width (§)		mm	2927	2994	2927	2994	2927	2994	—
		ft/in	<b>9'7"</b>	<b>9'9"</b>	<b>9'7"</b>	<b>9'9"</b>	<b>9'7"</b>	<b>9'9"</b>	—
Dump clearance at maximum lift and 45° discharge (§)		mm	2936	2821	2856	2738	2791	2672	495
		ft/in	<b>9'7"</b>	<b>9'3"</b>	<b>9'4"</b>	<b>8'11"</b>	<b>9'1"</b>	<b>8'9"</b>	<b>1'7"</b>
Reach at maximum lift and 45° discharge (§)		mm	1263	1377	1319	1430	1371	1481	67
		ft/in	<b>4'1"</b>	<b>4'6"</b>	<b>4'3"</b>	<b>4'8"</b>	<b>4'5"</b>	<b>4'10"</b>	<b>2"</b>
Reach at level lift arm and bucket level (§)		mm	2527	2688	2627	2788	2712	2873	405
		ft/in	<b>8'3"</b>	<b>8'9"</b>	<b>8'7"</b>	<b>9'1"</b>	<b>8'10"</b>	<b>9'5"</b>	<b>1'3"</b>
Digging depth (§)		mm	89	89	89	89	89	89	21
		in	<b>3.5</b>	<b>3.5</b>	<b>3.5</b>	<b>3.5</b>	<b>3.5</b>	<b>3.5</b>	<b>0.8</b>
Overall length		mm	7961	8135	8061	8235	8146	8320	605
		ft/in	<b>26'2"</b>	<b>26'9"</b>	<b>26'6"</b>	<b>27'1"</b>	<b>26'9"</b>	<b>27'4"</b>	<b>2'0"</b>
Overall height with bucket at maximum lift		mm	5363	5363	5325	5325	5529	5529	496
		ft/in	<b>17'8"</b>	<b>17'8"</b>	<b>17'6"</b>	<b>17'6"</b>	<b>18'2"</b>	<b>18'2"</b>	<b>1'8"</b>
Loader clearance circle with bucket at carry position (§)		mm	13 301	13 464	13 356	13 519	13 403	13 567	391
		ft/in	<b>43'8"</b>	<b>44'3"</b>	<b>43'10"</b>	<b>44'5"</b>	<b>44'0"</b>	<b>44'7"</b>	<b>1'4"</b>
Static tipping load, straight (ISO)*		kg	12 701	12 562	12 515	12 375	12 355	12 214	-341
		lb	<b>27,993</b>	<b>27,688</b>	<b>27,584</b>	<b>27,275</b>	<b>27,230</b>	<b>26,919</b>	<b>-751</b>
Static tipping load, straight (no tire deflection)*		kg	13 424	13 284	13 242	13 101	13 085	12 943	-398
		lb	<b>29,586</b>	<b>29,279</b>	<b>29,186</b>	<b>28,875</b>	<b>28,841</b>	<b>28,526</b>	<b>-878</b>
Static tipping load, articulated (ISO)*		kg	10 986	10 848	10 811	10 671	10 659	10 518	-416
		lb	<b>24,214</b>	<b>23,909</b>	<b>23,827</b>	<b>23,519</b>	<b>23,494</b>	<b>23,182</b>	<b>-917</b>
Static tipping load, articulated (no tire deflection)*		kg	11 711	11 571	11 540	11 398	11 392	11 249	-458
		lb	<b>25,812</b>	<b>25,504</b>	<b>25,434</b>	<b>25,122</b>	<b>25,108</b>	<b>24,793</b>	<b>-1011</b>
Breakout force** (§)		kN	163	162	150	149	140	138	-8
		lbf	<b>36,840</b>	<b>36,573</b>	<b>33,756</b>	<b>33,491</b>	<b>31,477</b>	<b>31,214</b>	<b>-1892</b>
Operating weight*		kg	18 231	18 339	18 320	18 428	18 395	18 503	1271
		lb	<b>40,180</b>	<b>40,418</b>	<b>40,376</b>	<b>40,614</b>	<b>40,541</b>	<b>40,779</b>	<b>2800</b>

\*Static tipping loads and operating weights shown are based on a global machine configuration with Michelin 23.5R25 XHA2 L3 Radial tires, full fluids, operator, standard counterweight, standard linkage, cold start, roading fenders, Product Link, open differential axles (front/rear), power train guard, secondary steering, and sound suppression.

\*\*Measured 102 mm (4") behind tip of cutting edge with bucket hinge pin as pivot point in accordance with SAE J732C.

(§) Specifications and ratings conform to all applicable standards recommended by the Society of Automotive Engineers, including SAE Standard J732C governing loader ratings.

(ISO) Full compliance to ISO 14397-1 (2007) Sections 1 thru 6, which requires 2% verification between calculations and testing.

(No Tire Deflection) Compliance to ISO 14397-1 (2007) Sections 1 thru 5.



Bucket Type		Material Handling – Pin On					High Lift Change in Specs
		Bolt-on Cutting Edges	Teeth & Segments	Bolt-on Cutting Edges	Teeth & Segments	Bolt-on Cutting Edges	
Edge Type							
Capacity – rated (§)	m <sup>3</sup>	3.20	3.20	3.40	3.40	3.60	3.60
	yd <sup>3</sup>	<b>4.19</b>	<b>4.19</b>	<b>4.45</b>	<b>4.45</b>	<b>4.71</b>	<b>4.71</b>
Capacity – rated @ 110% fill factor	m <sup>3</sup>	3.50	3.50	3.70	3.70	4.00	4.00
	yd <sup>3</sup>	<b>4.60</b>	<b>4.60</b>	<b>4.90</b>	<b>4.90</b>	<b>5.20</b>	<b>5.20</b>
Width (§)	mm	2927	2994	2927	2994	2927	2994
	ft/in	<b>9'7"</b>	<b>9'9"</b>	<b>9'7"</b>	<b>9'9"</b>	<b>9'7"</b>	<b>9'9"</b>
Dump clearance at maximum lift and 45° discharge (§)	mm	2756	2631	2721	2596	2686	2560
	ft/in	<b>9'0"</b>	<b>8'7"</b>	<b>8'11"</b>	<b>8'6"</b>	<b>8'9"</b>	<b>8'4"</b>
Reach at maximum lift and 45° discharge (§)	mm	1255	1358	1291	1393	1326	1428
	ft/in	<b>4'1"</b>	<b>4'5"</b>	<b>4'2"</b>	<b>4'6"</b>	<b>4'4"</b>	<b>4'8"</b>
Reach at level lift arm and bucket level (§)	mm	2672	2833	2722	2883	2772	2933
	ft/in	<b>8'9"</b>	<b>9'3"</b>	<b>8'11"</b>	<b>9'5"</b>	<b>9'1"</b>	<b>9'7"</b>
Digging depth (§)	mm	97	97	97	97	97	97
	in	<b>3.8</b>	<b>3.8</b>	<b>3.8</b>	<b>3.8</b>	<b>3.8</b>	<b>3.8</b>
Overall length	mm	8112	8286	8162	8336	8212	8386
	ft/in	<b>26'8"</b>	<b>27'3"</b>	<b>26'10"</b>	<b>27'5"</b>	<b>27'0"</b>	<b>27'7"</b>
Overall height with bucket at maximum lift	mm	5490	5490	5539	5539	5589	5589
	ft/in	<b>18'1"</b>	<b>18'1"</b>	<b>18'3"</b>	<b>18'3"</b>	<b>18'5"</b>	<b>18'5"</b>
Loader clearance circle with bucket at carry position (§)	mm	13 387	13 551	13 415	13 580	13 443	13 608
	ft/in	<b>44'0"</b>	<b>44'6"</b>	<b>44'1"</b>	<b>44'7"</b>	<b>44'2"</b>	<b>44'8"</b>
Static tipping load, straight (ISO)*	kg	12 307	12 168	12 214	12 074	12 127	11 986
	lb	<b>27,125</b>	<b>26,818</b>	<b>26,921</b>	<b>26,612</b>	<b>26,729</b>	<b>26,418</b>
Static tipping load, straight (no tire deflection)*	kg	13 020	12 879	12 929	12 787	12 845	12 702
	lb	<b>28,696</b>	<b>28,386</b>	<b>28,497</b>	<b>28,184</b>	<b>28,311</b>	<b>27,997</b>
Static tipping load, articulated (ISO)*	kg	10 624	10 485	10 536	10 396	10 454	10 312
	lb	<b>23,417</b>	<b>23,109</b>	<b>23,223</b>	<b>22,914</b>	<b>23,040</b>	<b>22,729</b>
Static tipping load, articulated (no tire deflection)*	kg	11 340	11 199	11 254	11 112	11 174	11 031
	lb	<b>24,993</b>	<b>24,683</b>	<b>24,804</b>	<b>24,492</b>	<b>24,628</b>	<b>24,313</b>
Breakout force** (§)	kN	144	143	138	137	133	132
	lbf	<b>32,489</b>	<b>32,223</b>	<b>31,199</b>	<b>30,934</b>	<b>29,997</b>	<b>29,733</b>
Operating weight*	kg	18 352	18 460	18 400	18 508	18 446	18 554
	lb	<b>40,446</b>	<b>40,684</b>	<b>40,552</b>	<b>40,790</b>	<b>40,653</b>	<b>40,892</b>

\*Static tipping loads and operating weights shown are based on a global machine configuration with Michelin 23.5R25 XHA2 L3 Radial tires, full fluids, operator, standard counterweight, standard linkage, cold start, roading fenders, Product Link, open differential axles (front/rear), power train guard, secondary steering, and sound suppression.

\*\*Measured 102 mm (4") behind tip of cutting edge with bucket hinge pin as pivot point in accordance with SAE J732C.

(§) Specifications and ratings conform to all applicable standards recommended by the Society of Automotive Engineers, including SAE Standard J732C governing loader ratings.

(ISO) Full compliance to ISO 14397-1 (2007) Sections 1 thru 6, which requires 2% verification between calculations and testing.

(No Tire Deflection) Compliance to ISO 14397-1 (2007) Sections 1 thru 5.

Bucket Type	General Purpose – Pin On						High Lift Change in Specs	
	Edge Type	Bolt-on Cutting Edges	Teeth & Segments	Bolt-on Cutting Edges	Teeth & Segments	Bolt-on Cutting Edges		Teeth & Segments
Capacity – rated (§)	m <sup>3</sup>	3.10	3.10	3.40	3.40	3.60	3.60	—
	yd <sup>3</sup>	<b>4.05</b>	<b>4.05</b>	<b>4.45</b>	<b>4.45</b>	<b>4.71</b>	<b>4.71</b>	—
Capacity – rated @ 110% fill factor	m <sup>3</sup>	3.40	3.40	3.70	3.70	4.00	4.00	—
	yd <sup>3</sup>	<b>4.50</b>	<b>4.50</b>	<b>4.90</b>	<b>4.90</b>	<b>5.20</b>	<b>5.20</b>	—
Width (§)	mm	2927	2994	2927	2994	2927	2994	—
	ft/in	<b>9'7"</b>	<b>9'9"</b>	<b>9'7"</b>	<b>9'9"</b>	<b>9'7"</b>	<b>9'9"</b>	—
Dump clearance at maximum lift and 45° discharge (§)	mm	3046	2928	2981	2862	2935	2816	305
	ft/in	<b>9'11"</b>	<b>9'7"</b>	<b>9'9"</b>	<b>9'4"</b>	<b>9'7"</b>	<b>9'2"</b>	<b>1'0"</b>
Reach at maximum lift and 45° discharge (§)	mm	1269	1380	1321	1431	1357	1467	117
	ft/in	<b>4'1"</b>	<b>4'6"</b>	<b>4'4"</b>	<b>4'8"</b>	<b>4'5"</b>	<b>4'9"</b>	<b>4"</b>
Reach at level lift arm and bucket level (§)	mm	2727	2888	2812	2973	2872	3033	305
	ft/in	<b>8'11"</b>	<b>9'5"</b>	<b>9'2"</b>	<b>9'9"</b>	<b>9'5"</b>	<b>9'11"</b>	<b>1'0"</b>
Digging depth (§)	mm	90	90	90	90	90	90	-35
	in	<b>3.5</b>	<b>3.5</b>	<b>3.5</b>	<b>3.5</b>	<b>3.5</b>	<b>3.5</b>	<b>-1.3</b>
Overall length	mm	8291	8464	8376	8549	8436	8609	375
	ft/in	<b>27'3"</b>	<b>27'10"</b>	<b>27'6"</b>	<b>28'1"</b>	<b>27'9"</b>	<b>28'3"</b>	<b>1'3"</b>
Overall height with bucket at maximum lift	mm	5515	5515	5719	5719	5777	5777	306
	ft/in	<b>18'2"</b>	<b>18'2"</b>	<b>18'10"</b>	<b>18'10"</b>	<b>19'0"</b>	<b>19'0"</b>	<b>1'1"</b>
Loader clearance circle with bucket at carry position (§)	mm	13 478	13 645	13 527	13 696	13 562	13 732	-5
	ft/in	<b>44'3"</b>	<b>44'10"</b>	<b>44'5"</b>	<b>45'0"</b>	<b>44'6"</b>	<b>45'1"</b>	<b>-1"</b>
Static tipping load, straight (ISO)*	kg	13 346	13 208	13 181	13 041	13 060	12 919	-1172
	lb	<b>29,416</b>	<b>29,110</b>	<b>29,052</b>	<b>28,744</b>	<b>28,784</b>	<b>28,474</b>	<b>-2583</b>
Static tipping load, straight (no tire deflection)*	kg	14 065	13 925	13 903	13 762	13 784	13 642	-1221
	lb	<b>30,999</b>	<b>30,691</b>	<b>30,643</b>	<b>30,332</b>	<b>30,380</b>	<b>30,067</b>	<b>-2691</b>
Static tipping load, articulated (ISO)*	kg	11 459	11 320	11 303	11 163	11 189	11 048	-1064
	lb	<b>25,255</b>	<b>24,950</b>	<b>24,913</b>	<b>24,605</b>	<b>24,661</b>	<b>24,351</b>	<b>-2345</b>
Static tipping load, articulated (no tire deflection)*	kg	12 190	12 050	12 038	11 897	11 926	11 784	-1109
	lb	<b>26,867</b>	<b>26,559</b>	<b>26,533</b>	<b>26,221</b>	<b>26,285</b>	<b>25,972</b>	<b>-2444</b>
Breakout force** (§)	kN	151	150	141	139	134	133	-9
	lbf	<b>33,973</b>	<b>33,715</b>	<b>31,680</b>	<b>31,423</b>	<b>30,214</b>	<b>29,958</b>	<b>-2109</b>
Operating weight*	kg	19 046	19 154	19 121	19 229	19 179	19 287	545
	lb	<b>41,976</b>	<b>42,214</b>	<b>42,141</b>	<b>42,379</b>	<b>42,269</b>	<b>42,507</b>	<b>1200</b>

\*Static tipping loads and operating weights shown are based on a global machine configuration with Michelin 23.5R25 XHA2 L3 Radial tires, full fluids, operator, standard counterweight, standard linkage, cold start, roading fenders, Product Link, open differential axles (front/rear), power train guard, secondary steering, and sound suppression.

\*\*Measured 102 mm (4") behind tip of cutting edge with bucket hinge pin as pivot point in accordance with SAE J732C.

(§) Specifications and ratings conform to all applicable standards recommended by the Society of Automotive Engineers, including SAE Standard J732C governing loader ratings.

(ISO) Full compliance to ISO 14397-1 (2007) Sections 1 thru 6, which requires 2% verification between calculations and testing.

(No Tire Deflection) Compliance to ISO 14397-1 (2007) Sections 1 thru 5.

Bucket Type		Material Handling – Pin On					High Lift Change in Specs
		Bolt-on Cutting Edges	Teeth & Segments	Bolt-on Cutting Edges	Teeth & Segments	Bolt-on Cutting Edges	
Edge Type							
Capacity – rated (§)	m <sup>3</sup>	3.40	3.40	3.60	3.60	3.80	3.80
	yd <sup>3</sup>	<b>4.45</b>	<b>4.45</b>	<b>4.71</b>	<b>4.71</b>	<b>4.97</b>	<b>4.97</b>
Capacity – rated @ 110% fill factor	m <sup>3</sup>	3.70	3.70	4.00	4.00	4.20	4.20
	yd <sup>3</sup>	<b>4.90</b>	<b>4.90</b>	<b>5.20</b>	<b>5.20</b>	<b>5.50</b>	<b>5.50</b>
Width (§)	mm	2927	2994	2927	2994	2927	2994
	ft/in	<b>9'7"</b>	<b>9'9"</b>	<b>9'7"</b>	<b>9'9"</b>	<b>9'7"</b>	<b>9'9"</b>
Dump clearance at maximum lift and 45° discharge (§)	mm	2911	2786	2876	2750	2833	2707
	ft/in	<b>9'6"</b>	<b>9'1"</b>	<b>9'5"</b>	<b>9'0"</b>	<b>9'3"</b>	<b>8'10"</b>
Reach at maximum lift and 45° discharge (§)	mm	1241	1343	1276	1378	1319	1421
	ft/in	<b>4'0"</b>	<b>4'4"</b>	<b>4'2"</b>	<b>4'6"</b>	<b>4'3"</b>	<b>4'7"</b>
Reach at level lift arm and bucket level (§)	mm	2822	2983	2872	3033	2933	3094
	ft/in	<b>9'3"</b>	<b>9'9"</b>	<b>9'5"</b>	<b>9'11"</b>	<b>9'7"</b>	<b>10'1"</b>
Digging depth (§)	mm	98	98	98	98	98	98
	in	<b>3.8</b>	<b>3.8</b>	<b>3.8</b>	<b>3.8</b>	<b>3.8</b>	<b>3.8</b>
Overall length	mm	8392	8565	8442	8615	8503	8676
	ft/in	<b>27'7"</b>	<b>28'2"</b>	<b>27'9"</b>	<b>28'4"</b>	<b>27'11"</b>	<b>28'6"</b>
Overall height with bucket at maximum lift	mm	5729	5729	5779	5779	5828	5828
	ft/in	<b>18'10"</b>	<b>18'10"</b>	<b>19'0"</b>	<b>19'0"</b>	<b>19'2"</b>	<b>19'2"</b>
Loader clearance circle with bucket at carry position (§)	mm	13 540	13 709	13 569	13 739	13 605	13 776
	ft/in	<b>44'6"</b>	<b>45'0"</b>	<b>44'7"</b>	<b>45'1"</b>	<b>44'8"</b>	<b>45'3"</b>
Static tipping load, straight (ISO)*	kg	13 039	12 900	12 949	12 809	12 835	12 694
	lb	<b>28,738</b>	<b>28,431</b>	<b>28,540</b>	<b>28,232</b>	<b>28,288</b>	<b>27,978</b>
Static tipping load, straight (no tire deflection)*	kg	13 746	13 605	13 659	13 518	13 547	13 405
	lb	<b>30,296</b>	<b>29,987</b>	<b>30,105</b>	<b>29,794</b>	<b>29,859</b>	<b>29,546</b>
Static tipping load, articulated (ISO)*	kg	11 180	11 040	11 094	10 955	10 987	10 846
	lb	<b>24,640</b>	<b>24,334</b>	<b>24,453</b>	<b>24,144</b>	<b>24,215</b>	<b>23,905</b>
Static tipping load, articulated (no tire deflection)*	kg	11 900	11 760	11 818	11 677	11 712	11 570
	lb	<b>26,228</b>	<b>25,919</b>	<b>26,047</b>	<b>25,736</b>	<b>25,815</b>	<b>25,502</b>
Breakout force** (§)	kN	139	138	134	133	128	127
	lbf	<b>31,403</b>	<b>31,144</b>	<b>30,195</b>	<b>29,936</b>	<b>28,825</b>	<b>28,568</b>
Operating weight*	kg	19 126	19 234	19 172	19 280	19 228	19 336
	lb	<b>42,152</b>	<b>42,390</b>	<b>42,254</b>	<b>42,492</b>	<b>42,377</b>	<b>42,615</b>

\*Static tipping loads and operating weights shown are based on a global machine configuration with Michelin 23.5R25 XHA2 L3 Radial tires, full fluids, operator, standard counterweight, standard linkage, cold start, roading fenders, Product Link, open differential axles (front/rear), power train guard, secondary steering, and sound suppression.

\*\*Measured 102 mm (4") behind tip of cutting edge with bucket hinge pin as pivot point in accordance with SAE J732C.

(§) Specifications and ratings conform to all applicable standards recommended by the Society of Automotive Engineers, including SAE Standard J732C governing loader ratings.

(ISO) Full compliance to ISO 14397-1 (2007) Sections 1 thru 6, which requires 2% verification between calculations and testing.

(No Tire Deflection) Compliance to ISO 14397-1 (2007) Sections 1 thru 5.

Bucket Type		General Purpose — Pin On								High Lift Delta	
		Bolt-on Cutting Edges	Teeth & Segments	Bolt-on Cutting Edges	Teeth & Segments	Bolt-on Cutting Edges	Teeth & Segments	Bolt-on Cutting Edges	Teeth & Segments		
Edge Type	Capacity — rated	m <sup>3</sup>	3.80	3.80	4.00	4.00	4.20	4.20	4.60	4.60	—
		yd <sup>3</sup>	<b>4.97</b>	<b>4.97</b>	<b>5.23</b>	<b>5.23</b>	<b>5.49</b>	<b>5.49</b>	<b>6.02</b>	<b>6.02</b>	—
Capacity — 110%		m <sup>3</sup>	4.18	4.18	4.40	4.40	4.62	4.62	5.06	5.06	—
		yd <sup>3</sup>	<b>5.47</b>	<b>5.47</b>	<b>5.75</b>	<b>5.75</b>	<b>6.04</b>	<b>6.04</b>	<b>6.62</b>	<b>6.62</b>	—
Width		mm	3220	3271	3220	3271	3220	3271	3220	3271	—
		ft/in	<b>10'6"</b>	<b>10'8"</b>	<b>10'6"</b>	<b>10'8"</b>	<b>10'6"</b>	<b>10'8"</b>	<b>10'6"</b>	<b>10'8"</b>	—
Dump clearance at maximum lift and 45° discharge		mm	3067	2915	3058	2905	2991	2837	2977	2823	558
		ft/in	<b>10'0"</b>	<b>9'6"</b>	<b>10'0"</b>	<b>9'6"</b>	<b>9'9"</b>	<b>9'3"</b>	<b>9'9"</b>	<b>9'3"</b>	<b>1'9"</b>
Reach at maximum lift and 45° discharge		mm	1327	1467	1334	1473	1388	1525	1400	1537	-25
		ft/in	<b>4'4"</b>	<b>4'9"</b>	<b>4'4"</b>	<b>4'10"</b>	<b>4'6"</b>	<b>5'0"</b>	<b>4'7"</b>	<b>5'0"</b>	<b>-1"</b>
Reach at level lift arm and bucket level		mm	2739	2943	2750	2955	2838	3043	2857	3062	404
		ft/in	<b>8'11"</b>	<b>9'7"</b>	<b>9'0"</b>	<b>9'8"</b>	<b>9'3"</b>	<b>9'11"</b>	<b>9'4"</b>	<b>10'0"</b>	<b>1'3"</b>
Digging depth		mm	124	124	124	124	124	124	124	124	-25
		in	<b>4.9</b>	<b>4.9</b>	<b>4.9</b>	<b>4.9</b>	<b>4.9</b>	<b>4.9</b>	<b>4.9</b>	<b>4.9</b>	<b>-1"</b>
Overall length		mm	8681	8906	8693	8918	8780	9005	8799	9024	697
		ft/in	<b>28'6"</b>	<b>29'3"</b>	<b>28'7"</b>	<b>29'4"</b>	<b>28'10"</b>	<b>29'7"</b>	<b>28'11"</b>	<b>29'8"</b>	<b>2'3"</b>
Overall height with bucket at maximum lift		mm	5788	5788	5902	5902	5902	5902	5874	5874	558
		ft/in	<b>19'0"</b>	<b>19'0"</b>	<b>19'5"</b>	<b>19'5"</b>	<b>19'5"</b>	<b>19'5"</b>	<b>19'4"</b>	<b>19'4"</b>	<b>1'9"</b>
Loader clearance circle with bucket at carry position		mm	14 727	14 899	14 733	14 905	14 778	14 951	14 787	14 961	481
		ft/in	<b>48'4"</b>	<b>48'11"</b>	<b>48'5"</b>	<b>48'11"</b>	<b>48'6"</b>	<b>49'1"</b>	<b>48'7"</b>	<b>49'1"</b>	<b>1'6"</b>
Static tipping load, straight (ISO)*		kg	16 045	15 863	16 024	15 842	15 831	15 648	15 822	15 636	372
		lb	<b>35,364</b>	<b>34,963</b>	<b>35,319</b>	<b>34,915</b>	<b>34,893</b>	<b>34,488</b>	<b>34,872</b>	<b>34,463</b>	<b>821</b>
Static tipping load, straight (rigid tire)*		kg	17 316	17 131	17 305	17 120	17 104	16 917	17 120	16 931	299
		lb	<b>38,164</b>	<b>37,757</b>	<b>38,141</b>	<b>37,733</b>	<b>37,697</b>	<b>37,287</b>	<b>37,732</b>	<b>37,318</b>	<b>658</b>
Static tipping load, articulated (ISO)*		kg	14 052	13 869	14 028	13 845	13 848	13 664	13 829	13 643	166
		lb	<b>30,971</b>	<b>30,569</b>	<b>30,918</b>	<b>30,514</b>	<b>30,522</b>	<b>30,117</b>	<b>30,479</b>	<b>30,070</b>	<b>366</b>
Static tipping load, articulated (rigid tire)*		kg	15 312	15 128	15 298	15 113	15 111	14 925	15 116	14 928	112
		lb	<b>33,749</b>	<b>33,342</b>	<b>33,718</b>	<b>33,309</b>	<b>33,304</b>	<b>32,894</b>	<b>33,316</b>	<b>32,901</b>	<b>248</b>
Breakout force**		kN	187	185	185	183	173	171	170	168	-14
		lbf	<b>42,151</b>	<b>41,781</b>	<b>41,695</b>	<b>41,326</b>	<b>38,984</b>	<b>38,618</b>	<b>38,277</b>	<b>37,912</b>	<b>-3170</b>
Operating weight*		kg	23 073	23 211	23 125	23 263	23 181	23 319	23 221	23 359	1763
		lb	<b>50,853</b>	<b>51,157</b>	<b>50,968</b>	<b>51,272</b>	<b>51,091</b>	<b>51,395</b>	<b>51,179</b>	<b>51,483</b>	<b>3888</b>

\*Static tipping loads and operating weights shown are based on standard machine configuration with 26.5R25 L3 Michelin XHA2 radial tires, power train guard, full fuel tank, coolants, lubricants, air conditioner and operator.

Static tipping loads conform to the international standard as defined in ISO 14397-1 (SEPT2007).

\*\*Measured 100 mm (4") behind tip of cutting edge with bucket hinge pin as pivot point in accordance with SAE J732 (APR2007).

**NOTE:** Specifications and ratings conform to all applicable standards recommended by the Society of Automotive Engineers, including SAE Standard J732 (APR2007) which governs loader ratings.

**NOTE:** Bucket availability varies by region. Consult your local dealer for availability.

Bucket Type		Rock – Pin On		Material Handling/Standard – Pin On				High Lift Delta
		Bolt-on Cutting Edges	Teeth & Segments	Bolt-on Cutting Edges	Teeth & Segments	Bolt-on Cutting Edges	Teeth & Segments	
Capacity – rated	m <sup>3</sup>	3.40	3.40	4.00	4.00	4.60	4.60	—
	yd <sup>3</sup>	<b>4.45</b>	<b>4.45</b>	<b>5.23</b>	<b>5.23</b>	<b>6.02</b>	<b>6.02</b>	—
Capacity – 110%	m <sup>3</sup>	3.74	3.74	4.40	4.40	5.06	5.06	—
	yd <sup>3</sup>	<b>4.89</b>	<b>4.89</b>	<b>5.75</b>	<b>5.75</b>	<b>6.62</b>	<b>6.62</b>	—
Width	mm	3252	3252	3220	3271	3220	3271	—
	ft/in	<b>10'8"</b>	<b>10'8"</b>	<b>10'6"</b>	<b>10'8"</b>	<b>10'6"</b>	<b>10'8"</b>	—
Dump clearance at maximum lift and 45° discharge	mm	3124	3026	2978	2815	2893	2730	558
	ft/in	<b>10'2"</b>	<b>9'11"</b>	<b>9'9"</b>	<b>9'2"</b>	<b>9'5"</b>	<b>8'11"</b>	<b>1'9"</b>
Reach at maximum lift and 45° discharge	mm	1454	1576	1252	1379	1337	1464	-25
	ft/in	<b>4'9"</b>	<b>5'2"</b>	<b>4'1"</b>	<b>4'6"</b>	<b>4'4"</b>	<b>4'9"</b>	<b>-1"</b>
Reach at level lift arm and bucket level	mm	2818	2974	2769	2973	2889	3093	404
	ft/in	<b>9'2"</b>	<b>9'9"</b>	<b>9'1"</b>	<b>9'9"</b>	<b>9'5"</b>	<b>10'1"</b>	<b>1'3"</b>
Digging depth	mm	68	68	124	124	124	124	-25
	in	<b>2.7</b>	<b>2.7</b>	<b>4.9</b>	<b>4.9</b>	<b>4.9</b>	<b>4.9</b>	<b>-1"</b>
Overall length	mm	8745	8906	8711	8936	8831	9056	697
	ft/in	<b>28'9"</b>	<b>29'3"</b>	<b>28'7"</b>	<b>29'4"</b>	<b>29'0"</b>	<b>29'9"</b>	<b>2'3"</b>
Overall height with bucket at maximum lift	mm	5845	5845	5858	5858	5982	5982	558
	ft/in	<b>19'3"</b>	<b>19'3"</b>	<b>19'3"</b>	<b>19'3"</b>	<b>19'8"</b>	<b>19'8"</b>	<b>1'9"</b>
Loader clearance circle with bucket at carry position	mm	14 813	14 901	14 742	14 914	14 804	14 978	481
	ft/in	<b>48'8"</b>	<b>48'11"</b>	<b>48'5"</b>	<b>49'0"</b>	<b>48'7"</b>	<b>49'2"</b>	<b>1'6"</b>
Static tipping load, straight (ISO)*	kg	16 255	16 185	15 834	15 653	15 622	15 438	372
	lb	<b>35,826</b>	<b>35,672</b>	<b>34,899</b>	<b>34,499</b>	<b>34,431</b>	<b>34,026</b>	<b>821</b>
Static tipping load, straight (rigid tire)*	kg	17 542	17 471	17 078	16 894	16 885	16 699	299
	lb	<b>38,663</b>	<b>38,507</b>	<b>37,640</b>	<b>37,235</b>	<b>37,216</b>	<b>36,805</b>	<b>658</b>
Static tipping load, articulated (ISO)*	kg	14 217	14 147	13 861	13 680	13 655	13 471	166
	lb	<b>31,334</b>	<b>31,180</b>	<b>30,551</b>	<b>30,151</b>	<b>30,096</b>	<b>29,690</b>	<b>366</b>
Static tipping load, articulated (rigid tire)*	kg	15 496	15 425	15 097	14 913	14 909	14 723	112
	lb	<b>34,153</b>	<b>33,998</b>	<b>33,274</b>	<b>32,870</b>	<b>32,861</b>	<b>32,450</b>	<b>248</b>
Breakout force**	kN	186	185	182	181	166	165	-14
	lbf	<b>41,828</b>	<b>41,704</b>	<b>41,111</b>	<b>40,742</b>	<b>37,481</b>	<b>37,117</b>	<b>-3170</b>
Operating weight*	kg	24 004	24 056	23 134	23 272	23 267	23 404	1763
	lb	<b>52,905</b>	<b>53,019</b>	<b>50,987</b>	<b>51,291</b>	<b>51,279</b>	<b>51,583</b>	<b>3888</b>

\*Static tipping loads and operating weights shown are based on standard machine configuration with 26.5R25 L3 Michelin XHA2 radial tires, power train guard, full fuel tank, coolants, lubricants, air conditioner and operator.

Static tipping loads conform to the international standard as defined in ISO 14397-1 (SEPT2007).

\*\*Measured 100 mm (4") behind tip of cutting edge with bucket hinge pin as pivot point in accordance with SAE J732 (APR2007).

**NOTE:** Specifications and ratings conform to all applicable standards recommended by the Society of Automotive Engineers, including SAE Standard J732 (APR2007) which governs loader ratings.

**NOTE:** Bucket availability varies by region. Consult your local dealer for availability.

Bucket Type		General Purpose – Pin On				Material Handling – Pin On		High Lift Delta
		Bolt-on Cutting Edges	Teeth & Segments	Bolt-on Cutting Edges	Teeth & Segments	Bolt-on Cutting Edges	Teeth & Segments	
Edge Type								
Capacity – rated	m <sup>3</sup>	4.20	4.20	4.60	4.60	4.60	4.60	–
	yd <sup>3</sup>	<b>5.49</b>	<b>5.49</b>	<b>6.02</b>	<b>6.02</b>	<b>6.02</b>	<b>6.02</b>	–
Capacity – 110%	m <sup>3</sup>	4.62	4.62	5.06	5.06	5.06	5.06	–
	yd <sup>3</sup>	<b>6.04</b>	<b>6.04</b>	<b>6.62</b>	<b>6.62</b>	<b>6.62</b>	<b>6.62</b>	–
Width	mm	3220	3271	3220	3271	3220	3271	–
	ft/in	<b>10'6"</b>	<b>10'8"</b>	<b>10'6"</b>	<b>10'8"</b>	<b>10'6"</b>	<b>10'8"</b>	–
Dump clearance at maximum lift and 45° discharge	mm	3225	3071	3187	3033	3120	2957	335
	ft/in	<b>10'6"</b>	<b>10'0"</b>	<b>10'5"</b>	<b>9'11"</b>	<b>10'2"</b>	<b>9'8"</b>	<b>1'1"</b>
Reach at maximum lift and 45° discharge	mm	1332	1470	1363	1500	1286	1413	23
	ft/in	<b>4'4"</b>	<b>4'9"</b>	<b>4'5"</b>	<b>4'11"</b>	<b>4'2"</b>	<b>4'7"</b>	<b>0"</b>
Reach at level lift arm and bucket level	mm	2955	3160	3004	3209	3014	3219	273
	ft/in	<b>9'8"</b>	<b>10'4"</b>	<b>9'10"</b>	<b>10'6"</b>	<b>9'10"</b>	<b>10'6"</b>	<b>10"</b>
Digging depth	mm	103	103	103	103	103	103	–4
	in	<b>4.0</b>	<b>4.0</b>	<b>4.0</b>	<b>4.0</b>	<b>4.0</b>	<b>4.0</b>	<b>–0.1</b>
Overall length	mm	9128	9352	9177	9401	9187	9411	336
	ft/in	<b>30'0"</b>	<b>30'9"</b>	<b>30'2"</b>	<b>30'11"</b>	<b>30'2"</b>	<b>30'11"</b>	<b>1'2"</b>
Overall height with bucket at maximum lift	mm	5937	5937	6195	6195	6162	6162	336
	ft/in	<b>19'6"</b>	<b>19'6"</b>	<b>20'4"</b>	<b>20'4"</b>	<b>20'3"</b>	<b>20'3"</b>	<b>1'2"</b>
Loader clearance circle with bucket at carry position	mm	14 925	15 105	14 951	15 133	14 957	15 139	332
	ft/in	<b>49'0"</b>	<b>49'7"</b>	<b>49'1"</b>	<b>49'8"</b>	<b>49'1"</b>	<b>49'8"</b>	<b>1'2"</b>
Static tipping load, straight (ISO)*	kg	18 040	17 857	17 926	17 742	17 868	17 684	–1591
	lb	<b>39,761</b>	<b>39,358</b>	<b>39,510</b>	<b>39,104</b>	<b>39,381</b>	<b>38,976</b>	<b>–3507</b>
Static tipping load, straight (rigid tire)*	kg	19 358	19 173	19 254	19 068	19 175	18 989	–1671
	lb	<b>42,666</b>	<b>42,258</b>	<b>42,436</b>	<b>42,026</b>	<b>42,262</b>	<b>41,853</b>	<b>–3683</b>
Static tipping load, articulated (ISO)*	kg	15 675	15 492	15 566	15 382	15 517	15 333	–1438
	lb	<b>34,548</b>	<b>34,144</b>	<b>34,308</b>	<b>33,902</b>	<b>34,200</b>	<b>33,795</b>	<b>–3170</b>
Static tipping load, articulated (rigid tire)*	kg	17 013	16 828	16 914	16 728	16 845	16 660	–1530
	lb	<b>37,498</b>	<b>37,090</b>	<b>37,279</b>	<b>36,868</b>	<b>37,128</b>	<b>36,719</b>	<b>–3372</b>
Breakout force**	kN	226	224	218	216	216	215	–6
	lbf	<b>50,833</b>	<b>50,524</b>	<b>49,005</b>	<b>48,696</b>	<b>48,673</b>	<b>48,365</b>	<b>–1424</b>
Operating weight*	kg	25 112	25 250	25 173	25 311	25 168	25 306	85
	lb	<b>55,346</b>	<b>55,650</b>	<b>55,480</b>	<b>55,784</b>	<b>55,469</b>	<b>55,773</b>	<b>186</b>

\*Static tipping loads and operating weights shown are based on standard machine configuration with 26.5R25 L3 Michelin XHA2 radial tires, power train guard, full fuel tank, coolants, lubricants, air conditioner and operator.

Static tipping loads conform to the international standard as defined in ISO 14397-1 (SEPT2007).

\*\*Measured 100 mm (4") behind tip of cutting edge with bucket hinge pin as pivot point in accordance with SAE J732 (APR2007).

**NOTE:** Specifications and ratings conform to all applicable standards recommended by the Society of Automotive Engineers, including SAE Standard J732 (APR2007) which governs loader ratings.

**NOTE:** Bucket availability varies by region. Consult your local dealer for availability.

Bucket Type		Rock – Pin On		Material Handling/Standard – Pin On				High Lift Delta
		Bolt-on Cutting Edges	Teeth & Segments	Bolt-on Cutting Edges	Teeth & Segments	Bolt-on Cutting Edges	Teeth & Segments	
Capacity – rated	m <sup>3</sup>	4.00	4.00	4.60	4.60	5.00	5.00	—
	yd <sup>3</sup>	<b>5.23</b>	<b>5.23</b>	<b>6.02</b>	<b>6.02</b>	<b>6.54</b>	<b>6.54</b>	—
Capacity – 110%	m <sup>3</sup>	4.40	4.40	5.06	5.06	5.50	5.50	—
	yd <sup>3</sup>	<b>5.75</b>	<b>5.75</b>	<b>6.62</b>	<b>6.62</b>	<b>7.19</b>	<b>7.19</b>	—
Width	mm	3252	3252	3220	3271	3220	3271	—
	ft/in	<b>10'8"</b>	<b>10'8"</b>	<b>10'6"</b>	<b>10'8"</b>	<b>10'6"</b>	<b>10'8"</b>	—
Dump clearance at maximum lift and 45° discharge	mm	3233	3142	3120	2957	3070	2908	335
	ft/in	<b>10'7"</b>	<b>10'3"</b>	<b>10'2"</b>	<b>9'8"</b>	<b>10'0"</b>	<b>9'6"</b>	<b>1'1"</b>
Reach at maximum lift and 45° discharge	mm	1463	1571	1286	1413	1335	1462	23
	ft/in	<b>4'9"</b>	<b>5'1"</b>	<b>4'2"</b>	<b>4'7"</b>	<b>4'4"</b>	<b>4'9"</b>	<b>0"</b>
Reach at level lift arm and bucket level	mm	3073	3214	3014	3219	3084	3289	273
	ft/in	<b>10'1"</b>	<b>10'6"</b>	<b>9'10"</b>	<b>10'6"</b>	<b>10'1"</b>	<b>10'9"</b>	<b>10"</b>
Digging depth	mm	44	44	103	103	103	103	-4
	in	<b>1.7</b>	<b>1.7</b>	<b>4.0</b>	<b>4.0</b>	<b>4.0</b>	<b>4.0</b>	<b>-0.1</b>
Overall length	mm	9235	9379	9187	9411	9257	9481	336
	ft/in	<b>30'4"</b>	<b>30'10"</b>	<b>30'2"</b>	<b>30'11"</b>	<b>30'5"</b>	<b>31'2"</b>	<b>1'2"</b>
Overall height with bucket at maximum lift	mm	6159	6159	6162	6162	6223	6223	336
	ft/in	<b>20'3"</b>	<b>20'3"</b>	<b>20'3"</b>	<b>20'3"</b>	<b>20'5"</b>	<b>20'5"</b>	<b>1'2"</b>
Loader clearance circle with bucket at carry position	mm	15 039	15 123	14 957	15 139	14 996	15 178	332
	ft/in	<b>49'5"</b>	<b>49'8"</b>	<b>49'1"</b>	<b>49'8"</b>	<b>49'3"</b>	<b>49'10"</b>	<b>1'2"</b>
Static tipping load, straight (ISO)*	kg	18 511	18 441	17 888	17 703	17 758	17 573	-1591
	lb	<b>40,798</b>	<b>40,644</b>	<b>39,425</b>	<b>39,019</b>	<b>39,139</b>	<b>38,731</b>	<b>-3507</b>
Static tipping load, straight (rigid tire)*	kg	19 876	19 806	19 195	19 009	19 078	18 891	-1671
	lb	<b>43,808</b>	<b>43,652</b>	<b>42,306</b>	<b>41,895</b>	<b>42,049</b>	<b>41,636</b>	<b>-3683</b>
Static tipping load, articulated (ISO)*	kg	16 080	16 009	15 537	15 353	15 410	15 225	-1438
	lb	<b>35,440</b>	<b>35,285</b>	<b>34,244</b>	<b>33,838</b>	<b>33,965</b>	<b>33,556</b>	<b>-3170</b>
Static tipping load, articulated (rigid tire)*	kg	17 467	17 396	16 865	16 679	16 752	16 564	-1530
	lb	<b>38,498</b>	<b>38,342</b>	<b>37,172</b>	<b>36,761</b>	<b>36,921</b>	<b>36,508</b>	<b>-3372</b>
Breakout force**	kN	220	220	216	215	206	204	-6
	lbf	<b>49,563</b>	<b>49,451</b>	<b>48,687</b>	<b>48,377</b>	<b>46,309</b>	<b>46,001</b>	<b>-1424</b>
Operating weight*	kg	25 969	26 020	25 146	25 284	25 230	25 368	85
	lb	<b>57,236</b>	<b>57,348</b>	<b>55,422</b>	<b>55,726</b>	<b>55,607</b>	<b>55,911</b>	<b>186</b>

\*Static tipping loads and operating weights shown are based on standard machine configuration with 26.5R25 L3 Michelin XHA2 radial tires, power train guard, full fuel tank, coolants, lubricants, air conditioner and operator.

Static tipping loads conform to the international standard as defined in ISO 14397-1 (SEPT2007).

\*\*Measured 100 mm (4") behind tip of cutting edge with bucket hinge pin as pivot point in accordance with SAE J732 (APR2007).

**NOTE:** Specifications and ratings conform to all applicable standards recommended by the Society of Automotive Engineers, including SAE Standard J732 (APR2007) which governs loader ratings.

**NOTE:** Bucket availability varies by region. Consult your local dealer for availability.

Bucket Type	General Purpose – Pin On						High Lift Delta	
	Bolt-on Cutting Edges	Teeth & Segments	Bolt-on Cutting Edges	Teeth & Segments	Bolt-on Cutting Edges	Teeth & Segments		
Edge Type								
Capacity – rated	m <sup>3</sup> yd <sup>3</sup>	5.40 <b>7.06</b>	5.40 <b>7.06</b>	5.70 <b>7.46</b>	5.70 <b>7.46</b>	6.00 <b>7.85</b>	6.00 <b>7.85</b>	— —
Capacity – 110%	m <sup>3</sup> yd <sup>3</sup>	5.94 <b>7.77</b>	5.94 <b>7.77</b>	6.27 <b>8.20</b>	6.27 <b>8.20</b>	6.60 <b>8.63</b>	6.60 <b>8.63</b>	— —
Width	mm ft/in	3447 <b>11'3"</b>	3535 <b>11'7"</b>	3447 <b>11'3"</b>	3535 <b>11'7"</b>	3447 <b>11'3"</b>	3535 <b>11'7"</b>	— —
Dump clearance at maximum lift and 45° discharge	mm ft/in	3242 <b>10'7"</b>	3077 <b>10'1"</b>	3174 <b>10'4"</b>	3007 <b>9'10"</b>	3156 <b>10'4"</b>	2989 <b>9'9"</b>	220 <b>8"</b>
Reach at maximum lift and 45° discharge	mm ft/in	1580 <b>5'2"</b>	1717 <b>5'7"</b>	1628 <b>5'4"</b>	1762 <b>5'9"</b>	1649 <b>5'4"</b>	1784 <b>5'10"</b>	2 <b>0"</b>
Reach at level lift arm and bucket level	mm ft/in	3064 <b>10'0"</b>	3276 <b>10'8"</b>	3148 <b>10'3"</b>	3360 <b>11'0"</b>	3176 <b>10'5"</b>	3388 <b>11'1"</b>	160 <b>6"</b>
Digging depth	mm in	133 <b>5.2</b>	133 <b>5.2</b>	133 <b>5.2</b>	133 <b>5.2</b>	133 <b>5.2</b>	133 <b>5.2</b>	-1 <b>-0</b>
Overall length	mm ft/in	9637 <b>31'8"</b>	9878 <b>32'5"</b>	9721 <b>31'11"</b>	9962 <b>32'9"</b>	9749 <b>32'0"</b>	9990 <b>32'10"</b>	200 <b>8"</b>
Overall height with bucket at maximum lift	mm ft/in	6391 <b>21'0"</b>	6391 <b>21'0"</b>	6213 <b>20'5"</b>	6213 <b>20'5"</b>	6239 <b>20'6"</b>	6239 <b>20'6"</b>	221 <b>9"</b>
Loader clearance circle with bucket at carry position	mm ft/in	15 857 <b>52'1"</b>	16 080 <b>52'10"</b>	15 902 <b>52'3"</b>	16 125 <b>52'11"</b>	15 917 <b>52'3"</b>	16 141 <b>53'0"</b>	175 <b>7"</b>
Static tipping load, straight (ISO)*	kg lb	20 504 <b>45,192</b>	20 322 <b>44,790</b>	20 272 <b>44,681</b>	20 089 <b>44,277</b>	20 136 <b>44,379</b>	19 952 <b>43,974</b>	-1720 <b>-3792</b>
Static tipping load, straight (rigid tire)*	kg lb	22 086 <b>48,678</b>	21 900 <b>48,268</b>	21 855 <b>48,168</b>	21 667 <b>47,755</b>	21 719 <b>47,870</b>	21 531 <b>47,456</b>	-1950 <b>-4299</b>
Static tipping load, articulated (ISO)*	kg lb	17 895 <b>39,441</b>	17 710 <b>39,035</b>	17 677 <b>38,961</b>	17 492 <b>38,552</b>	17 544 <b>38,667</b>	17 358 <b>38,257</b>	-1550 <b>-3416</b>
Static tipping load, articulated (rigid tire)*	kg lb	19 764 <b>43,561</b>	19 578 <b>43,150</b>	19 546 <b>43,079</b>	19 358 <b>42,666</b>	19 414 <b>42,789</b>	19 226 <b>42,375</b>	-1787 <b>-3939</b>
Breakout force**	kN lbf	201 <b>45,379</b>	199 <b>44,838</b>	190 <b>42,792</b>	188 <b>42,264</b>	186 <b>41,931</b>	184 <b>41,407</b>	3 <b>719</b>
Operating weight*	kg lb	29 945 <b>65,999</b>	30 084 <b>66,304</b>	30 028 <b>66,182</b>	30 167 <b>66,487</b>	30 124 <b>66,393</b>	30 263 <b>66,698</b>	115 <b>253</b>

\*Static tipping loads and operating weights shown are based on standard machine configuration with 29.5R25, L3 Michelin XHA2 radial tires, power train guard, full fuel tank, coolant, lubricants, air conditioner and operator.

Static tipping loads conform to the international standard as defined in ISO 14397-1 (SEPT2007).

\*\*Measured 100 mm (4") behind tip of cutting edge with bucket hinge pin as pivot point in accordance with SAE J732 (APR2007).

**NOTE:** Specifications and ratings conform to all applicable standards recommended by the Society of Automotive Engineers, including SAE Standard J732 (APR2007) which governs loader ratings.

**NOTE:** Bucket availability varies by region. Consult your local dealer for availability.



# Wheel Loaders Integrated Toolcarriers

## Performance Data ● 980H

Bucket Type		Material Handling – Pin On		Rock – Pin On		Coal – Pin On	General Purpose/ Heavy Duty – Pin On		High Lift Delta
		Bolt-on Cutting Edges	Teeth & Segments	Bolt-on Cutting Edges	Teeth & Segments	Bolt-on Cutting Edges	Bolt-on Cutting Edges	Teeth & Segments	
Capacity – rated	m <sup>3</sup>	5.70	5.70	4.40	4.40	8.20	5.70	5.70	–
	yd <sup>3</sup>	<b>7.46</b>	<b>7.46</b>	<b>5.75</b>	<b>5.75</b>	<b>10.73</b>	<b>7.46</b>	<b>7.46</b>	–
Capacity – 110%	m <sup>3</sup>	6.27	6.27	4.84	4.84	9.02	6.27	6.27	–
	yd <sup>3</sup>	<b>8.20</b>	<b>8.20</b>	<b>6.33</b>	<b>6.33</b>	<b>11.80</b>	<b>8.20</b>	<b>8.20</b>	–
Width	mm	3447	3535	3504	3504	3638	3447	3535	–
	ft/in	<b>11'3"</b>	<b>11'7"</b>	<b>11'5"</b>	<b>11'5"</b>	<b>11'11"</b>	<b>11'3"</b>	<b>11'7"</b>	–
Dump clearance at maximum lift and 45° discharge	mm	3075	2898	3101	3101	2887	3174	3007	220
	ft/in	<b>10'1"</b>	<b>9'6"</b>	<b>10'2"</b>	<b>10'2"</b>	<b>9'5"</b>	<b>10'4"</b>	<b>9'10"</b>	<b>8"</b>
Reach at maximum lift and 45° discharge	mm	1543	1665	1844	1844	1724	1628	1762	2
	ft/in	<b>5'0"</b>	<b>5'5"</b>	<b>6'0"</b>	<b>6'0"</b>	<b>5'7"</b>	<b>5'4"</b>	<b>5'9"</b>	<b>0"</b>
Reach at level lift arm and bucket level	mm	3173	3385	3360	3360	3435	3148	3360	160
	ft/in	<b>10'4"</b>	<b>11'1"</b>	<b>11'0"</b>	<b>11'0"</b>	<b>11'3"</b>	<b>10'3"</b>	<b>11'0"</b>	<b>6"</b>
Digging depth	mm	133	133	106	106	138	133	133	–1
	in	<b>5.2</b>	<b>5.2</b>	<b>4.1</b>	<b>4.1</b>	<b>5.4</b>	<b>5.2</b>	<b>5.2</b>	<b>–0</b>
Overall length	mm	9746	9987	9949	9949	10 011	9721	9962	200
	ft/in	<b>32'0"</b>	<b>32'10"</b>	<b>32'8"</b>	<b>32'8"</b>	<b>32'11"</b>	<b>31'11"</b>	<b>32'9"</b>	<b>8"</b>
Overall height with bucket at maximum lift	mm	6212	6212	6184	6184	6506	6213	6213	221
	ft/in	<b>20'5"</b>	<b>20'5"</b>	<b>20'4"</b>	<b>20'4"</b>	<b>21'5"</b>	<b>20'5"</b>	<b>20'5"</b>	<b>9"</b>
Loader clearance circle with bucket at carry position	mm	15 916	16 139	16 094	16 093	16 236	15 902	16 125	175
	ft/in	<b>52'3"</b>	<b>53'0"</b>	<b>52'10"</b>	<b>52'10"</b>	<b>53'4"</b>	<b>52'3"</b>	<b>52'11"</b>	<b>7"</b>
Static tipping load, straight (ISO)*	kg	19 825	19 643	21 253	21 285	19 512	20 116	19 932	–1720
	lb	<b>43,694</b>	<b>43,295</b>	<b>46,843</b>	<b>46,913</b>	<b>43,006</b>	<b>44,336</b>	<b>43,932</b>	<b>–3792</b>
Static tipping load, straight (rigid tire)*	kg	21 360	21 175	22 897	22 940	21 151	21 694	21 507	–1950
	lb	<b>47,078</b>	<b>46,670</b>	<b>50,466</b>	<b>50,560</b>	<b>46,616</b>	<b>47,815</b>	<b>47,402</b>	<b>–4299</b>
Static tipping load, articulated (ISO)*	kg	17 271	17 088	18 537	18 550	16 932	17 519	17 334	–1550
	lb	<b>38,067</b>	<b>37,663</b>	<b>40,857</b>	<b>40,884</b>	<b>37,318</b>	<b>38,613</b>	<b>38,204</b>	<b>–3416</b>
Static tipping load, articulated (rigid tire)*	kg	19 091	18 906	20 482	20 509	18 854	19 385	19 198	–1787
	lb	<b>42,078</b>	<b>41,670</b>	<b>45,144</b>	<b>45,202</b>	<b>41,556</b>	<b>42,726</b>	<b>42,313</b>	<b>–3939</b>
Breakout force**	kN	187	184	190	189	157	189	187	3
	lbf	<b>42,029</b>	<b>41,504</b>	<b>42,739</b>	<b>42,551</b>	<b>35,358</b>	<b>42,665</b>	<b>42,136</b>	<b>719</b>
Operating weight*	kg	30 153	30 292	31 109	31 184	30 532	30 175	30 313	115
	lb	<b>66,457</b>	<b>66,762</b>	<b>68,564</b>	<b>68,730</b>	<b>67,293</b>	<b>66,504</b>	<b>66,809</b>	<b>253</b>

\*Static tipping loads and operating weights shown are based on standard machine configuration with 29.5R25, L3 Michelin XHA2 radial tires, power train guard, full fuel tank, coolant, lubricants, air conditioner and operator.

Static tipping loads conform to the international standard as defined in ISO 14397-1 (SEPT2007).

\*\*Measured 100 mm (4") behind tip of cutting edge with bucket hinge pin as pivot point in accordance with SAE J732 (APR2007).

**NOTE:** Specifications and ratings conform to all applicable standards recommended by the Society of Automotive Engineers, including SAE Standard J732 (APR2007) which governs loader ratings.

**NOTE:** Bucket availability varies by region. Consult your local dealer for availability.

Bucket Type		Rock — Pin On					Rock/ Heavy Duty/Extra Wide Bucket — Pin On	High Lift Delta
		Teeth & Segments + Side Protector	Teeth + Side Protector	Teeth & Segments + Side Protector	Teeth + Side Protector	Teeth + Side Protector	Teeth & Segments + Side Protector	
Edge Type								
Capacity — rated	m <sup>3</sup> yd <sup>3</sup>	4.48 <b>5.86</b>	4.31 <b>5.64</b>	5.66 <b>7.40</b>	5.38 <b>7.03</b>	5.38 <b>7.03</b>	5.41 <b>7.07</b>	— —
Capacity — 110%	m <sup>3</sup> yd <sup>3</sup>	4.93 <b>6.45</b>	4.75 <b>6.21</b>	6.22 <b>8.14</b>	5.91 <b>7.74</b>	5.91 <b>7.74</b>	5.95 <b>7.78</b>	— —
Width	mm ft/in	3504 <b>11'5"</b>	3504 <b>11'5"</b>	3504 <b>11'5"</b>	3504 <b>11'5"</b>	3510 <b>11'6"</b>	3645 <b>11'11"</b>	— —
Dump clearance at maximum lift and 45° discharge	mm ft/in	3051 <b>10'0"</b>	3051 <b>10'0"</b>	2890 <b>9'5"</b>	2890 <b>9'5"</b>	2983 <b>9'9"</b>	2941 <b>9'7"</b>	220 <b>8"</b>
Reach at maximum lift and 45° discharge	mm ft/in	1788 <b>5'10"</b>	1788 <b>5'10"</b>	1979 <b>6'5"</b>	1979 <b>6'5"</b>	1930 <b>6'4"</b>	1965 <b>6'5"</b>	2 <b>0"</b>
Reach at level lift arm and bucket level	mm ft/in	3359 <b>11'0"</b>	3359 <b>11'0"</b>	3608 <b>11'10"</b>	3608 <b>11'10"</b>	3512 <b>11'6"</b>	3561 <b>11'8"</b>	160 <b>6"</b>
Digging depth	mm in	106 <b>4.1</b>	71 <b>2.8</b>	106 <b>4.1</b>	71 <b>2.8</b>	77 <b>3.0</b>	77 <b>3.0</b>	-1 <b>-0</b>
Overall length	mm ft/in	9948 <b>32'8"</b>	9948 <b>32'8"</b>	10 197 <b>33'6"</b>	10 197 <b>33'6"</b>	10 069 <b>33'1"</b>	10 156 <b>33'4"</b>	200 <b>8"</b>
Overall height with bucket at maximum lift	mm ft/in	6204 <b>20'5"</b>	6204 <b>20'5"</b>	6378 <b>21'0"</b>	6378 <b>21'0"</b>	6378 <b>21'0"</b>	6378 <b>21'0"</b>	221 <b>9"</b>
Loader clearance circle with bucket at carry position	mm ft/in	16 093 <b>52'10"</b>	16 093 <b>52'10"</b>	16 235 <b>53'4"</b>	16 235 <b>53'4"</b>	16 156 <b>53'1"</b>	16 340 <b>53'8"</b>	175 <b>7"</b>
Static tipping load, straight (ISO)*	kg lb	20 998 <b>46,279</b>	21 519 <b>47,428</b>	20 119 <b>44,343</b>	20 693 <b>45,607</b>	20 705 <b>45,635</b>	19 813 <b>43,669</b>	-1720 <b>-3792</b>
Static tipping load, straight (rigid tire)*	kg lb	22 649 <b>49,918</b>	23 190 <b>51,112</b>	21 764 <b>47,968</b>	22 361 <b>49,285</b>	22 374 <b>49,313</b>	21 461 <b>47,301</b>	-1950 <b>-4299</b>
Static tipping load, articulated (ISO)*	kg lb	18 265 <b>40,257</b>	18 775 <b>41,381</b>	17 439 <b>38,436</b>	17 995 <b>39,663</b>	18 008 <b>39,690</b>	17 091 <b>37,669</b>	-1550 <b>-3416</b>
Static tipping load, articulated (rigid tire)*	kg lb	20 223 <b>44,572</b>	20 750 <b>45,733</b>	19 387 <b>42,730</b>	19 965 <b>44,003</b>	19 977 <b>44,031</b>	19 053 <b>41,993</b>	-1787 <b>-3939</b>
Breakout force**	kN lbf	188 <b>42,289</b>	204 <b>45,879</b>	159 <b>35,932</b>	172 <b>38,725</b>	184 <b>41,402</b>	173 <b>38,896</b>	3 <b>719</b>
Operating weight*	kg lb	31 475 <b>69,370</b>	31 175 <b>68,709</b>	31 821 <b>70,132</b>	31 521 <b>69,471</b>	31 517 <b>69,463</b>	32 239 <b>71,055</b>	115 <b>253</b>

\*Static tipping loads and operating weights shown are based on standard machine configuration with 29.5R25, L3 Michelin XHA2 radial tires, power train guard, full fuel tank, coolant, lubricants, air conditioner and operator.

Static tipping loads conform to the international standard as defined in ISO 14397-1 (SEPT2007).

\*\*Measured 100 mm (4") behind tip of cutting edge with bucket hinge pin as pivot point in accordance with SAE J732 (APR2007).

**NOTE:** Specifications and ratings conform to all applicable standards recommended by the Society of Automotive Engineers, including SAE Standard J732 (APR2007) which governs loader ratings.

**NOTE:** Bucket availability varies by region. Consult your local dealer for availability.

Bucket Type		Standard Lift			High Lift			
		Rock Teeth & Segments	Rock Teeth & Segments	Rock Teeth & Segments	Rock Teeth & Segments	Rock Teeth & Segments	Rock Teeth & Segments	
Cutting Edge Type		Spade	Spade	Spade	Spade	Spade	Spade	
Bucket Part Number		369-2020	369-2030	369-2040	369-2020	369-2030	369-2040	
Capacity — struck	m <sup>3</sup>	4.4	4.8	5.1	4.4	4.8	5.1	
	yd <sup>3</sup>	<b>5.8</b>	<b>6.2</b>	<b>6.7</b>	<b>5.8</b>	<b>6.2</b>	<b>6.7</b>	
Heaped capacity — rated	m <sup>3</sup>	5.4	5.7	6.1	5.4	5.7	6.1	
	yd <sup>3</sup>	<b>7.0</b>	<b>7.5</b>	<b>8.0</b>	<b>7.0</b>	<b>7.5</b>	<b>8.0</b>	
Width	mm	3772	3772	3772	3772	3772	3772	
	ft	<b>12.4</b>	<b>12.4</b>	<b>12.4</b>	<b>12.4</b>	<b>12.4</b>	<b>12.4</b>	
Dump clearance at full lift and 45° discharge	Edge	mm	3420	3374	3328	3879	3833	3787
		ft	<b>11.2</b>	<b>11.1</b>	<b>10.9</b>	<b>12.7</b>	<b>12.6</b>	<b>12.4</b>
	With Teeth	mm	3280	3234	3188	3739	3693	3647
		ft	<b>10.8</b>	<b>10.6</b>	<b>10.5</b>	<b>12.3</b>	<b>12.1</b>	<b>12.0</b>
Reach at lift and 45° discharge	Edge	mm	1858	1904	1950	1798	1840	1882
		ft	<b>6.1</b>	<b>6.2</b>	<b>6.4</b>	<b>5.9</b>	<b>6.0</b>	<b>6.2</b>
	With Teeth	mm	1976	2022	2068	1904	1946	1988
		ft	<b>6.5</b>	<b>6.6</b>	<b>6.8</b>	<b>6.2</b>	<b>6.4</b>	<b>6.5</b>
Reach with lift arms horizontal and bucket level	mm	3657	3722	3787	4021	4086	4151	
	ft	<b>12.0</b>	<b>12.2</b>	<b>12.4</b>	<b>13.2</b>	<b>13.4</b>	<b>13.6</b>	
Digging depth	mm	160	160	160	208	208	208	
	in	<b>6.3</b>	<b>6.3</b>	<b>6.3</b>	<b>8.2</b>	<b>8.2</b>	<b>8.2</b>	
Overall length	mm	10 842	10 907	10 972	11 290	11 355	11 420	
	ft	<b>35.6</b>	<b>35.8</b>	<b>36.0</b>	<b>37.0</b>	<b>37.3</b>	<b>37.5</b>	
Overall height with bucket at full raise	mm	6609	6671	6734	7067	7130	7193	
	ft	<b>21.7</b>	<b>21.9</b>	<b>22.1</b>	<b>23.2</b>	<b>23.4</b>	<b>23.6</b>	
Loader clearance turning radius — SAE carry with teeth	mm	8607.5	8624	8640.5	8806	8824	8842	
	ft	<b>28.3</b>	<b>28.3</b>	<b>28.4</b>	<b>28.9</b>	<b>29.0</b>	<b>29.0</b>	
Full dump angle	degrees	-50	-50	-50	-50	-50	-50	
Static tipping load — straight**	kg	29 147	28 969	28 791	24 759	24 595	24 431	
	lb	<b>64,259</b>	<b>63,867</b>	<b>63,472</b>	<b>54,584</b>	<b>54,224</b>	<b>53,862</b>	
Static tipping load — straight*	kg	27 698	27 509	27 319	23 632	23 458	23 284	
	lb	<b>61,064</b>	<b>60,647</b>	<b>60,228</b>	<b>52,100</b>	<b>51,716</b>	<b>51,332</b>	
Static tipping load — full turn (articulated 35°)**	kg	25 845	25 673	25 501	21 845	21 686	21 527	
	lb	<b>56,979</b>	<b>56,600</b>	<b>56,220</b>	<b>48,159</b>	<b>47,809</b>	<b>47,458</b>	
Static tipping load — full turn (articulated 35°)*	kg	23 846	23 661	23 476	20 251	20 081	19 911	
	lb	<b>52,571</b>	<b>52,164</b>	<b>51,756</b>	<b>44,646</b>	<b>44,271</b>	<b>43,896</b>	
Breakout force	kN	356	341	328	355	341	328	
	lbf	<b>79,945</b>	<b>76,722</b>	<b>73,722</b>	<b>79,869</b>	<b>76,650</b>	<b>73,652</b>	
Operating weight	kg	42 011	42 118	42 225	42 836	42 943	43 050	
	lb	<b>92,618</b>	<b>92,855</b>	<b>93,090</b>	<b>94,437</b>	<b>94,673</b>	<b>94,909</b>	
Weight distribution at SAE carry — unloaded	Front	kg	20 493	20 689	20 885	22 262	22 472	22 680
		lb	<b>45,178</b>	<b>45,612</b>	<b>46,044</b>	<b>49,079</b>	<b>49,541</b>	<b>50,002</b>
	Rear	kg	21 518	21 429	21 340	20 574	20 472	20 370
		lb	<b>47,439</b>	<b>47,242</b>	<b>47,046</b>	<b>45,358</b>	<b>45,132</b>	<b>44,907</b>
Weight distribution at SAE carry — loaded	Front	kg	37 109	37 340	37 571	38 451	38 691	38 931
		lb	<b>81,811</b>	<b>82,320</b>	<b>82,830</b>	<b>84,769</b>	<b>85,299</b>	<b>85,828</b>
	Rear	kg	14 902	14 778	14 654	13 457	13 324	13 191
		lb	<b>32,853</b>	<b>32,580</b>	<b>32,307</b>	<b>29,668</b>	<b>29,375</b>	<b>29,081</b>

\*Tipping Load is calculated with tire squash.

\*\*Tipping Load is calculated without tire squash.

Bucket Type		Standard Lift Aggregate Package					
		General Purpose	General Purpose	General Purpose	General Purpose	Coal	
Ground Engaging Tools		Segments	Segments	Segments	Segments	Segments	
Cutting Edge Type		Straight	Straight	Straight	Straight	Straight	
Bucket Part Number		436-8310	436-8320	436-8330	477-1900	436-8340	
Capacity — struck	m <sup>3</sup>	5.2	5.9	6.6	7.3	9.0	
	yd <sup>3</sup>	<b>6.8</b>	<b>7.7</b>	<b>8.6</b>	<b>9.6</b>	<b>11.8</b>	
Heaped capacity — rated	m <sup>3</sup>	6.1	6.9	7.7	8.4	10.3	
	yd <sup>3</sup>	<b>8.0</b>	<b>9.0</b>	<b>10.0</b>	<b>11.0</b>	<b>13.5</b>	
Width	mm	3687	3687	3687	3729	3729	
	ft	<b>12.1</b>	<b>12.1</b>	<b>12.1</b>	<b>12.2</b>	<b>12.2</b>	
Dump clearance at full lift and 45° discharge (edge)	mm	3560	3471	3386	3222	3266	
	ft	<b>11.7</b>	<b>11.4</b>	<b>11.1</b>	<b>10.6</b>	<b>10.7</b>	
Reach at lift and 45° discharge (edge)	mm	1743	1831	1917	2081	2012	
	ft	<b>5.7</b>	<b>6.0</b>	<b>6.3</b>	<b>6.8</b>	<b>6.6</b>	
Reach with lift arms horizontal and bucket level	mm	3294	3419	3540	3772	3692	
	ft	<b>10.8</b>	<b>11.2</b>	<b>11.6</b>	<b>12.4</b>	<b>12.1</b>	
Digging depth	mm	143	143	143	143	160	
	in	<b>0.5</b>	<b>0.5</b>	<b>0.5</b>	<b>0.5</b>	<b>0.5</b>	
Overall length	mm	10 487	10 612	10 733	10 965	10 899	
	ft	<b>34.4</b>	<b>34.8</b>	<b>35.2</b>	<b>36.0</b>	<b>35.8</b>	
Overall height with bucket at full raise	mm	6844	6965	7063	7000	7394	
	ft	<b>22.5</b>	<b>22.9</b>	<b>23.2</b>	<b>23.0</b>	<b>24.3</b>	
Loader clearance turning radius — SAE carry with teeth	mm	8636.5	8668	8699	8760.5	8771	
	ft	<b>28.4</b>	<b>28.5</b>	<b>28.6</b>	<b>28.8</b>	<b>28.8</b>	
Full dump angle	degrees	-50	-50	-50	-50	-50	
Static tipping load — straight**	kg	34 164	33 787	33 420	32 625	33 128	
	lb	<b>75,318</b>	<b>74,488</b>	<b>73,677</b>	<b>71,926</b>	<b>73,036</b>	
Static tipping load — straight*	kg	32 318	31 919	31 531	30 751	31 068	
	lb	<b>71,249</b>	<b>70,369</b>	<b>69,514</b>	<b>67,794</b>	<b>68,493</b>	
Static tipping load — full turn (articulated 35°)**	kg	30 271	29 910	29 558	28 808	29 245	
	lb	<b>66,737</b>	<b>65,940</b>	<b>65,164</b>	<b>63,510</b>	<b>64,473</b>	
Static tipping load — full turn (articulated 35°)*	kg	27 633	27 244	26 866	26 134	26 341	
	lb	<b>60,920</b>	<b>60,063</b>	<b>59,229</b>	<b>57,616</b>	<b>58,072</b>	
Breakout force	kN	400	367	340	297	307	
	lbf	<b>89,924</b>	<b>82,515</b>	<b>76,334</b>	<b>66,675</b>	<b>69,100</b>	
Operating weight	kg	45 665	45 877	46 084	46 376	46 606	
	lb	<b>100,675</b>	<b>101,142</b>	<b>101,597</b>	<b>102,242</b>	<b>102,749</b>	
Weight distribution at SAE carry — unloaded	Front	kg	20 525	20 909	21 283	21 875	22 219
	Rear	kg	25 141	24 969	24 801	24 501	24 388
	Front	lb	<b>45,249</b>	<b>46,096</b>	<b>46,921</b>	<b>48,226</b>	<b>48,984</b>
	Rear	lb	<b>55,425</b>	<b>55,046</b>	<b>54,676</b>	<b>54,015</b>	<b>53,765</b>
Weight distribution at SAE carry — loaded	Front	kg	41 648	42 118	42 577	43 323	37 678
	Rear	kg	16 719	16 461	16 208	15 755	18 000
	Front	lb	<b>91,817</b>	<b>92,853</b>	<b>93,865</b>	<b>95,510</b>	<b>83,065</b>
	Rear	lb	<b>36,858</b>	<b>36,290</b>	<b>35,733</b>	<b>34,733</b>	<b>39,684</b>

\*Tipping Load is calculated with tire squash.

\*\*Tipping Load is calculated without tire squash.

Bucket Type		988K HL Tires: 35/65 R33 XLDD1 PN: 339-8790 SLR: 978 mm						
		Standard Lift						
		General Purpose		Rock			Heavy Duty Rock	
Ground Engaging Tools		Adapters or BOCE	Adapters or BOCE	K130	K131	K132	K133	
Cutting Edge Type		Straight	Straight	Spade	Spade	Spade	Spade	
Bucket Part Number		347-4990	347-4980	347-4960	347-4950	347-4970	339-1370	
Struck capacity	m <sup>3</sup>	6.0	5.5	6.5	5.5	5.0	5.0	
	yd <sup>3</sup>	<b>7.8</b>	<b>7.2</b>	<b>8.5</b>	<b>7.2</b>	<b>6.5</b>	<b>6.5</b>	
Heaped capacity — rated	m <sup>3</sup>	7.6	6.9	7.6	6.9	6.4	6.4	
	yd <sup>3</sup>	<b>10.0</b>	<b>9.0</b>	<b>10.0</b>	<b>9.0</b>	<b>8.3</b>	<b>8.3</b>	
Bucket width	mm	3897	3897	4020	4020	4020	4080	
	ft	<b>12.8</b>	<b>12.8</b>	<b>13.2</b>	<b>13.2</b>	<b>13.2</b>	<b>13.4</b>	
Dump clearance at full lift and 45° discharge	Bare	mm	3810	3894	3595	3807	3728	3714
		ft	<b>12.5</b>	<b>12.8</b>	<b>11.8</b>	<b>12.5</b>	<b>12.2</b>	<b>12.2</b>
	With teeth	mm	3810	3894	3402	3445	3535	3509
		ft	<b>12.5</b>	<b>12.8</b>	<b>11.2</b>	<b>11.3</b>	<b>11.6</b>	<b>11.5</b>
Reach at lift and 45° discharge	Bare	mm	1730	1653	1944	1778	1811	1824
		ft	<b>5.7</b>	<b>5.4</b>	<b>6.4</b>	<b>5.8</b>	<b>5.9</b>	<b>6.0</b>
	With teeth	mm	1730	1653	2127	2074	1994	1998
		ft	<b>5.7</b>	<b>5.4</b>	<b>7.0</b>	<b>6.8</b>	<b>6.5</b>	<b>6.6</b>
Reach with lift arms horizontal and bucket level — teeth	mm	3668	3554	4237	4144	4049	4071	
	ft	<b>12.0</b>	<b>11.7</b>	<b>13.9</b>	<b>13.6</b>	<b>13.3</b>	<b>13.4</b>	
Digging depth — segment	mm	203	198	204	204	204	204	
	in	<b>8.0</b>	<b>8.0</b>	<b>8.0</b>	<b>8.0</b>	<b>8.0</b>	<b>8.0</b>	
Overall length bucket level ground	mm	11 716	11 598	12 286	12 204	12 098	12 119	
	ft	<b>38.4</b>	<b>38.1</b>	<b>40.3</b>	<b>40.0</b>	<b>39.7</b>	<b>39.8</b>	
Overall height with bucket at full raise	mm	7583	7479	7549	7447	7373	7376	
	ft	<b>24.9</b>	<b>24.5</b>	<b>24.8</b>	<b>24.4</b>	<b>24.2</b>	<b>24.2</b>	
Loader clearance turning radius — SAE carry with teeth	mm	8620	8586.5	8700	8669	8647.5	8658.5	
	ft	<b>28.3</b>	<b>28.2</b>	<b>28.6</b>	<b>28.5</b>	<b>28.4</b>	<b>28.4</b>	
Full dump angle	degrees	<b>51</b>	<b>51</b>	<b>51</b>	<b>51</b>	<b>51</b>	<b>51</b>	
Static tipping load — straight*	kg	34 768	35 148	33 811	34 249	34 390	33 331	
	lb	<b>76,650</b>	<b>77,488</b>	<b>74,541</b>	<b>75,506</b>	<b>75,817</b>	<b>73,483</b>	
Static tipping load — full turn (articulated 35°)*	kg	31 139	31 508	30 196	30 625	30 760	29 703	
	lb	<b>68,649</b>	<b>69,462</b>	<b>66,571</b>	<b>67,517</b>	<b>67,815</b>	<b>65,484</b>	
Static tipping load — full turn (articulated 43°)*	kg	29 377	29 740	28 441	28 866	28 998	27 941	
	lb	<b>64,765</b>	<b>65,566</b>	<b>62,701</b>	<b>63,638</b>	<b>63,930</b>	<b>61,600</b>	
Breakout force	kN	437	468	371	392	410	402	
	lbf	<b>98,316</b>	<b>105,297</b>	<b>83,330</b>	<b>88,207</b>	<b>92,170</b>	<b>90,383</b>	
Operating weight	kg	50 306	50 065	50 873	50 530	50 502	51 481	
	lb	<b>110,905</b>	<b>110,375</b>	<b>112,155</b>	<b>111,399</b>	<b>111,337</b>	<b>113,496</b>	
Weight distribution at SAE carry — unloaded	Front	kg	27 450	27 034	28 538	27 979	27 880	29 476
		lb	<b>60,516</b>	<b>59,600</b>	<b>62,916</b>	<b>61,683</b>	<b>61,465</b>	<b>64,982</b>
	Rear	kg	22 856	23 031	22 335	22 551	22 622	22 005
		lb	<b>50,388</b>	<b>50,775</b>	<b>49,239</b>	<b>49,716</b>	<b>49,873</b>	<b>48,514</b>
Weight distribution at SAE carry — loaded	Front	kg	45 653	45 177	46 776	46 164	46 028	47 629
		lb	<b>100,649</b>	<b>99,599</b>	<b>103,123</b>	<b>101,773</b>	<b>101,474</b>	<b>105,003</b>
	Rear	kg	15 992	16 228	15 437	15 706	15 814	15 192
		lb	<b>35,257</b>	<b>35,777</b>	<b>34,032</b>	<b>34,627</b>	<b>34,864</b>	<b>33,493</b>

Tire spec used for Tipping Load specifications includes 35-65R33 (L-4) Michelin XLDD1 tires.

\*Tipping Load is calculated without tire squash.

Bucket Type		988K HL Tires: 35/65 R33 XLDD1 PN: 339-8790 SLR: 978 mm						
		High Lift						
		General Purpose		Rock			Heavy Duty Rock	
Ground Engaging Tools		Adapters or BOCE	Adapters or BOCE	K130	K131	K132	K133	
Cutting Edge Type		Straight	Straight	Spade	Spade	Spade	Spade	
Bucket Part Number		347-4990	347-4980	347-4960	347-4950	347-4970	339-1370	
Struck capacity	m <sup>3</sup>	6.0	5.5	6.5	5.5	5.0	5.0	
	yd <sup>3</sup>	<b>7.8</b>	<b>7.2</b>	<b>8.5</b>	<b>7.2</b>	<b>6.5</b>	<b>6.5</b>	
Heaped capacity — rated	m <sup>3</sup>	7.6	6.9	7.6	6.9	6.4	6.4	
	yd <sup>3</sup>	<b>10.0</b>	<b>9.0</b>	<b>10.0</b>	<b>9.0</b>	<b>8.3</b>	<b>8.3</b>	
Bucket width	mm	3897	3897	4020	4020	4020	4080	
	ft	<b>12.8</b>	<b>12.8</b>	<b>13.2</b>	<b>13.2</b>	<b>13.2</b>	<b>13.4</b>	
Dump clearance at full lift and 45° discharge	Bare	mm	4211	4296	3997	4074	4130	4116
		ft	<b>13.8</b>	<b>14.1</b>	<b>13.1</b>	<b>13.4</b>	<b>13.5</b>	<b>13.5</b>
	With teeth	mm	4211	4296	3804	3882	3937	3911
		ft	<b>13.8</b>	<b>14.1</b>	<b>12.5</b>	<b>12.7</b>	<b>12.9</b>	<b>12.8</b>
Reach at lift and 45° discharge	Bare	mm	1811	1734	2024	1947	1892	1905
		ft	<b>5.9</b>	<b>5.7</b>	<b>6.6</b>	<b>6.4</b>	<b>6.2</b>	<b>6.2</b>
	With teeth	mm	1811	1734	2208	2130	2075	2079
		ft	<b>5.9</b>	<b>5.7</b>	<b>7.2</b>	<b>7.0</b>	<b>6.8</b>	<b>6.8</b>
Reach with lift arms horizontal and bucket level — teeth	mm	4007	3893	4576	4466	4388	4410	
	ft	<b>13.1</b>	<b>12.8</b>	<b>15.0</b>	<b>14.7</b>	<b>14.4</b>	<b>14.5</b>	
Digging depth — segment	mm	219	214	220	220	220	220	
	in	<b>9.0</b>	<b>8.0</b>	<b>9.0</b>	<b>9.0</b>	<b>9.0</b>	<b>9.0</b>	
Overall length bucket level ground	mm	12 122	12 005	12 692	12 582	12 504	12 525	
	ft	<b>39.8</b>	<b>39.4</b>	<b>41.6</b>	<b>41.3</b>	<b>41.0</b>	<b>41.1</b>	
Overall height with bucket at full raise	mm	7985	7881	7951	7849	7775	7778	
	ft	<b>26.2</b>	<b>25.9</b>	<b>26.1</b>	<b>25.7</b>	<b>25.5</b>	<b>25.5</b>	
Loader clearance turning radius — SAE carry with teeth	mm	8797.5	8762.5	8877.5	8845.5	8823.5	8835.5	
	ft	<b>28.9</b>	<b>28.8</b>	<b>29.2</b>	<b>29.0</b>	<b>28.9</b>	<b>29.0</b>	
Full dump angle	degrees	<b>-50</b>	<b>-50</b>	<b>-50</b>	<b>-50</b>	<b>-50</b>	<b>-50</b>	
Static tipping load — straight*	kg	32 742	33 084	31 833	32 240	32 352	31 299	
	lb	<b>72,183</b>	<b>72,937</b>	<b>70,179</b>	<b>71,077</b>	<b>71,325</b>	<b>69,003</b>	
Static tipping load — full turn (articulated 35°)*	kg	29 193	29 527	28 296	28 698	28 806	27 754	
	lb	<b>64,360</b>	<b>65,096</b>	<b>62,383</b>	<b>63,268</b>	<b>63,507</b>	<b>61,188</b>	
Static tipping load — full turn (articulated 43°)*	kg	27 470	27 801	26 580	26 978	27 085	26 033	
	lb	<b>60,562</b>	<b>61,290</b>	<b>58,598</b>	<b>59,477</b>	<b>59,712</b>	<b>57,394</b>	
Breakout force	kN	403	431	341	361	377	370	
	lbf	<b>90,535</b>	<b>97,001</b>	<b>76,634</b>	<b>81,154</b>	<b>84,841</b>	<b>83,123</b>	
Operating weight	kg	51 648	51 408	52 216	51 873	51 845	52 824	
	lb	<b>113,865</b>	<b>113,335</b>	<b>115,116</b>	<b>114,359</b>	<b>114,298</b>	<b>116,456</b>	
Weight distribution at SAE carry — unloaded	Front	kg	27 950	27 515	29 086	28 497	28 398	30 082
		lb	<b>61,619</b>	<b>60,660</b>	<b>64,124</b>	<b>62,826</b>	<b>62,608</b>	<b>66,320</b>
	Rear	kg	23 698	23 893	23 129	23 375	23 446	22 742
		lb	<b>52,246</b>	<b>52,675</b>	<b>50,991</b>	<b>51,534</b>	<b>51,690</b>	<b>50,137</b>
Weight distribution at SAE carry — loaded	Front	kg	47 141	46 651	48 312	47 674	47 542	49 232
		lb	<b>103,928</b>	<b>102,848</b>	<b>106,509</b>	<b>105,104</b>	<b>104,813</b>	<b>108,538</b>
	Rear	kg	15 847	16 097	15 244	15 538	15 642	14 931
		lb	<b>34,937</b>	<b>35,487</b>	<b>33,607</b>	<b>34,256</b>	<b>34,485</b>	<b>32,918</b>

Tire spec used for Tipping Load specifications includes 35-65R33 (L-4) Michelin XLDD1 tires.

\*Tipping Load is calculated without tire squash.

# Wheel Loaders Integrated Toolcarriers

## Performance Data ● 988K Aggregate Package

			988K Standard Lift Tires: 35/65 R33 XLDD1, PN: 339-8790, SLR: 978 mm			
			Standard Lift Aggregate Package			
			General Purpose			
Bucket Type			Adapters or BOCE	Adapters or BOCE	Adapters or BOCE	Adapters or BOCE
Ground Engaging Tools			Straight	Straight	Straight	Straight
Cutting Edge Type			472-0120	435-4029	347-4990	347-4980
Bucket Part Number						
Struck capacity	m <sup>3</sup>		8.0	7.0	6.0	5.5
		yd <sup>3</sup>	<b>10.5</b>	<b>9.2</b>	<b>7.8</b>	<b>7.2</b>
Heaped capacity — rated	m <sup>3</sup>		9.6	8.4	7.6	6.9
		yd <sup>3</sup>	<b>12.5</b>	<b>11.0</b>	<b>10.0</b>	<b>9.0</b>
Bucket width	mm		3897	3897	3897	3897
		ft	<b>12.8</b>	<b>12.8</b>	<b>12.8</b>	<b>12.8</b>
Dump clearance at full lift and 45° discharge (bare)	mm		3642	3741	3818	3902
		ft	<b>11.9</b>	<b>12.3</b>	<b>12.5</b>	<b>12.8</b>
Reach at lift and 45° discharge (bare)	mm		1898	1787	1722	1645
		ft	<b>6.2</b>	<b>5.9</b>	<b>5.7</b>	<b>5.4</b>
Digging depth — segment	mm		200	208	200	195
		in	<b>7.9</b>	<b>8.2</b>	<b>7.9</b>	<b>7.7</b>
Overall length bucket level ground	mm		11 965	11 822	11 716	11 598
		ft	<b>39.3</b>	<b>38.8</b>	<b>38.4</b>	<b>38.1</b>
Overall height with bucket at full raise	mm		7830	7688	7591	7487
		ft	<b>25.7</b>	<b>25.2</b>	<b>24.9</b>	<b>24.6</b>
Loader clearance turning radius — SAE carry bare	mm		8691	8651.5	8620	8586
		ft	<b>28.5</b>	<b>28.4</b>	<b>28.3</b>	<b>28.2</b>
Full dump angle	degrees		<b>-49.8</b>	<b>-49.8</b>	<b>-49.8</b>	<b>-49.8</b>
Static tipping load — straight (rigid tire)	kg		39 436	39 922	40 321	40 726
		lb	<b>86,941</b>	<b>88,013</b>	<b>88,892</b>	<b>89,785</b>
Static tipping load — straight (tire squash)	kg		37 085	37 603	38 008	38 428
		lb	<b>81,758</b>	<b>82,900</b>	<b>83,793</b>	<b>84,719</b>
Static tipping load — full turn (articulated 35°) (rigid tire)	kg		35 173	35 641	36 031	36 423
		lb	<b>77,543</b>	<b>78,575</b>	<b>79,435</b>	<b>80,299</b>
Static tipping load — full turn (articulated 35°) (tire squash)	kg		31 461	31 981	32 383	32 799
		lb	<b>69,360</b>	<b>70,506</b>	<b>71,392</b>	<b>72,309</b>
Static tipping load — full turn (articulated 43°) (rigid tire)	kg		33 104	33 563	33 949	34 334
		lb	<b>72,982</b>	<b>73,994</b>	<b>74,845</b>	<b>75,693</b>
Static tipping load — full turn (articulated 43°) (tire squash)	kg		29 003	29 519	29 918	30 327
		lb	<b>63,941</b>	<b>65,078</b>	<b>65,958</b>	<b>66,860</b>
Breakout force	kN		381	413	437	468
		lbf	<b>85,652</b>	<b>92,846</b>	<b>98,241</b>	<b>105,211</b>
Operating weight	kg		53 379	53 104	52 816	52 576
		lb	<b>117,681</b>	<b>117,074</b>	<b>116,439</b>	<b>115,909</b>
Weight distribution at SAE carry — unloaded	Front	kg	27 257	26 781	26 290	25 875
		lb	<b>60,090</b>	<b>59,042</b>	<b>57,960</b>	<b>57,044</b>
	Rear	kg	26 123	26 323	26 526	26 701
		lb	<b>57,591</b>	<b>58,033</b>	<b>58,479</b>	<b>58,865</b>
Weight distribution at SAE carry — loaded	Front	kg	50 724	50 137	49 596	49 103
		lb	<b>111,828</b>	<b>110,533</b>	<b>109,341</b>	<b>108,253</b>
	Rear	kg	17 170	17 482	17 735	17 988
		lb	<b>37,853</b>	<b>38,542</b>	<b>39,098</b>	<b>39,656</b>

Tire spec used for Tipping Load specifications includes 35-65R33 (L-4) Michelin XLDD1 tires.

			990K STD Tires: 45/65R39 VSDL SLR: 1203 mm			
			Standard Lift			
Bucket Type			Rock			Heavy Duty
Ground Engaging Tools			Teeth & Segments	Teeth & Segments	Teeth & Segments	Teeth & Segments
Cutting Edge Type			Spade	Spade	Spade	Spade
Bucket Part Number			361-6110	361-6120	361-6140	361-6150
Struck capacity		m <sup>3</sup>	7.0	7.5	8.0	7.0
		yd <sup>3</sup>	9.1	9.9	10.5	9.1
Heaped capacity — rated		m <sup>3</sup>	8.6	9.2	10.0	8.6
		yd <sup>3</sup>	11.25	12.0	13.0	11.25
Bucket width		mm	4610	4610	4610	4610
		ft	15.1	15.1	15.1	15.1
Dump clearance at full lift and 45° discharge	Bare	mm	4234	4186	4106	4217
		ft	13.9	13.7	13.5	13.8
	With teeth	mm	4060	4012	3932	4014
		ft	13.3	13.2	12.9	13.2
Reach at lift and 45° discharge	Bare	mm	2027	2074	2138	2027
		ft	6.6	6.8	7.0	6.6
	With teeth	mm	2194	2241	2305	2188
		ft	7.2	7.4	7.6	7.2
Reach with lift arms horizontal and bucket level — teeth		mm	4331	4398	4488	4347
		ft	14.2	14.4	14.7	14.3
Digging depth — segment		mm	113	113	113	113
		in	4.5	4.5	4.5	4.5
Overall length — bucket level ground		mm	13 072	13 139	13 229	13 088
		ft	42.9	43.1	43.4	42.9
Overall height with bucket at full raise		mm	8293	8359	8359	8293
		ft	27.2	27.4	27.4	27.2
Loader clearance turning radius — SAE carry with teeth		mm	10 431.5	10 449	10 473	10 348
		ft	34.2	34.3	34.4	34.4
Full dump angle		degrees	-45	-45	-45	-45
Static tipping load — straight*		kg	49 513	49 233	49 280	47 872
		lb	109,158	108,540	108,644	105,540
Static tipping load — full turn (articulated 35°)*		kg	44 180	43 908	43 934	42 537
		lb	94,401	96,801	96,858	93,778
Breakout force		kN	590	570	546	584
		lbf	132,617	128,103	122,733	131,034
Operating weight		kg	80 974	81 147	81 299	82 511
		lb	178,517	178,899	179,233	181,906
Weight distribution at SAE carry — unloaded	Front	kg	44 827	45 142	45 396	47 414
		lb	98,827	99,522	100,080	104,529
	Rear	kg	36 147	36 005	35 903	35 097
		lb	79,690	79,377	79,153	77,377
Weight distribution at SAE carry — loaded	Front	kg	70 939	71 103	71 536	73 510
		lb	156,395	157,197	157,710	162,062
	Rear	kg	25 909	25 719	25 638	24 876
		lb	57,120	56,700	56,521	54,842

\*Tipping Load is calculated without tire squash.



			990K STD Tires: 45/65R39 VSDL SLR: 1203 mm			
			High Lift			
Bucket Type			Rock		Heavy Duty	
Ground Engaging Tools			Teeth & Segments	Teeth & Segments	Teeth & Segments	Teeth & Segments
Cutting Edge Type			Spade	Spade	Spade	Spade
Bucket Part Number			361-6110	361-6120	361-6140	361-6150
Struck capacity		m <sup>3</sup>	7.0	7.5	8.0	7.0
		yd <sup>3</sup>	<b>9.1</b>	<b>9.9</b>	<b>10.5</b>	<b>9.1</b>
Heaped capacity — rated		m <sup>3</sup>	8.6	9.2	10	8.6
		yd <sup>3</sup>	<b>11.25</b>	<b>12</b>	<b>13</b>	<b>11.25</b>
Bucket width		mm	4610	4610	4610	4610
		ft	<b>15.1</b>	<b>15.1</b>	<b>15.1</b>	<b>15.1</b>
Dump clearance at full lift and 45° discharge	Bare	mm	4895	4647	4585	4695
		ft	<b>15.4</b>	<b>15.2</b>	<b>15.0</b>	<b>15.4</b>
	With teeth	mm	4521	4473	4410	4492
		ft	<b>14.8</b>	<b>14.7</b>	<b>14.5</b>	<b>14.7</b>
Reach at lift and 45° discharge	Bare	mm	2416	2463	2527	2416
		ft	<b>7.9</b>	<b>8.1</b>	<b>8.3</b>	<b>7.9</b>
	With teeth	mm	2583	2630	2694	2578
		ft	<b>8.5</b>	<b>8.6</b>	<b>8.8</b>	<b>8.5</b>
Reach with lift arms horizontal and bucket level — teeth		mm	4931	4998	5088	4947
		ft	<b>16.2</b>	<b>16.4</b>	<b>16.7</b>	<b>16.2</b>
Digging depth		mm	155	155	155	155
		in	<b>6.1</b>	<b>6.1</b>	<b>6.1</b>	<b>6.1</b>
Overall length		mm	13 811	13 878	13 968	13 827
		ft	<b>45.3</b>	<b>45.5</b>	<b>45.8</b>	<b>45.4</b>
Overall height with bucket at full raise		mm	8754	8820	8820	8754
		ft	<b>28.7</b>	<b>28.9</b>	<b>28.9</b>	<b>28.7</b>
Loader clearance turning radius — SAE carry with teeth		mm	10 742	10 945	10 973.5	10 811
		ft	<b>35.6</b>	<b>35.9</b>	<b>36.0</b>	<b>35.5</b>
Full dump angle		degrees	<b>-51</b>	<b>-51</b>	<b>-51</b>	<b>-51</b>
Static tipping load — straight*		kg	45 117	44 834	44 814	43 510
		lb	<b>99,465</b>	<b>98,842</b>	<b>98,798</b>	<b>95,924</b>
Static tipping load — full turn (articulated 35°)*		kg	39 904	39 631	39 596	38 295
		lb	<b>87,974</b>	<b>87,372</b>	<b>87,294</b>	<b>84,426</b>
Breakout force		kN	556	537	514	550
		lbf	<b>124,982</b>	<b>120,704</b>	<b>115,628</b>	<b>123,669</b>
Operating weight		kg	85 599	85 772	85 924	87 136
		lb	<b>188,713</b>	<b>189,094</b>	<b>189,429</b>	<b>192,102</b>
Weight distribution at SAE carry — unloaded	Front	kg	46 516	46 860	47 139	49 363
		lb	<b>102,551</b>	<b>103,309</b>	<b>103,923</b>	<b>108,826</b>
	Rear	kg	39 082	38 912	38 785	37 773
		lb	<b>86,162</b>	<b>85,786</b>	<b>85,506</b>	<b>83,275</b>
Weight distribution at SAE carry — loaded	Front	kg	75 305	75 696	75 953	78 137
		lb	<b>166,019</b>	<b>166,882</b>	<b>167,449</b>	<b>172,263</b>
	Rear	kg	26 169	25 950	25 845	24 874
		lb	<b>57,692</b>	<b>57,211</b>	<b>56,979</b>	<b>54,837</b>

\*Tipping Load is calculated without tire squash.

Bucket Type	Standard Lift						
	Rock			Heavy Duty Rock		High Abrasion Rock	
	Teeth & Segments	Teeth & Segments	Teeth & Segments	Teeth & Segments	Teeth & Segments	Teeth & Segments	Teeth & Segments
<b>Ground Engaging Tools</b>							
<b>Cutting Edge Type</b>		Spade	Spade	Spade	Spade	Spade	Spade
Rated bucket capacity (\$) <b>m<sup>3</sup></b>	10.7	11.5	12.3	10.7	11.5	10.7	10.7
<b>yd<sup>3</sup></b>	<b>14.0</b>	<b>15.0</b>	<b>16.0</b>	<b>14.0</b>	<b>15.0</b>	<b>14.0</b>	<b>14.0</b>
Operating load at rated capacity <b>kg</b>	21 773	21 773	21 773	21 773	21 773	21 773	21 773
<b>lb</b>	<b>48,000</b>	<b>48,000</b>	<b>48,000</b>	<b>48,000</b>	<b>48,000</b>	<b>48,000</b>	<b>48,000</b>
Struck capacity (\$) <b>m<sup>3</sup></b>	8.9	9.5	10.2	8.9	9.5	8.9	8.9
<b>yd<sup>3</sup></b>	<b>11.6</b>	<b>12.4</b>	<b>13.3</b>	<b>11.6</b>	<b>12.4</b>	<b>11.6</b>	<b>11.6</b>
Bucket width (\$) <b>mm</b>	4824	4884	4824	5068	4824	5165	5068
<b>ft/in</b>	<b>15'10"</b>	<b>16'0"</b>	<b>15'10"</b>	<b>16'7"</b>	<b>15'10"</b>	<b>16'11"</b>	<b>16'7"</b>
Dump clearance at full lift SAE 45° discharge (\$) <b>mm</b>	4849	4785	4741	4849	4788	4935	4935
<b>ft/in</b>	<b>15'11"</b>	<b>15'8"</b>	<b>15'7"</b>	<b>15'11"</b>	<b>15'8"</b>	<b>16'2"</b>	<b>16'2"</b>
<b>Tooth tip mm</b>	4607	4548	4495	4612	4545	4699	4699
<b>ft/in</b>	<b>15'1"</b>	<b>14'11"</b>	<b>14'8"</b>	<b>15'1"</b>	<b>14'11"</b>	<b>15'5"</b>	<b>15'5"</b>
Reach at full lift SAE 45° discharge (\$) <b>mm</b>	2092	2149	2194	2092	2151	2036	2036
<b>ft/in</b>	<b>6'11"</b>	<b>7'0"</b>	<b>7'2"</b>	<b>6'11"</b>	<b>7'11"</b>	<b>6'10"</b>	<b>6'10"</b>
<b>Tooth tip mm</b>	2326	2378	2427	2322	2385	2292	2292
<b>ft/in</b>	<b>7'7"</b>	<b>7'10"</b>	<b>8'0"</b>	<b>7'7"</b>	<b>7'10"</b>	<b>7'6"</b>	<b>7'6"</b>
Reach with boom horizontal and bucket level <b>mm</b>	5114	5193	5265	5108	5200	5025	5025
<b>ft/in</b>	<b>16'10"</b>	<b>17'0"</b>	<b>17'4"</b>	<b>16'10"</b>	<b>17'1"</b>	<b>16'6"</b>	<b>16'6"</b>
Digging depth (segment) (\$) <b>mm</b>	196	201	201	196	198	175	175
<b>in</b>	<b>7.7</b>	<b>7.9</b>	<b>7.9</b>	<b>7.7</b>	<b>7.8</b>	<b>6.9</b>	<b>6.9</b>
Overall length — bucket level ground (\$) <b>mm</b>	15 736	15 818	15 890	15 729	15 823	15 632	15 632
<b>ft/in</b>	<b>51'7"</b>	<b>51'11"</b>	<b>51'1"</b>	<b>51'7"</b>	<b>51'11"</b>	<b>51'4"</b>	<b>51'4"</b>
Overall height with bucket at full raise (\$) <b>mm</b>	9313	9313	9492	9313	9313	9392	9313
<b>ft/in</b>	<b>30'7"</b>	<b>30'7"</b>	<b>31'1"</b>	<b>30'7"</b>	<b>30'7"</b>	<b>30'10"</b>	<b>30'7"</b>
Loader clearance radius with bucket in carry position (\$) <b>mm</b>	11 097	11 121	11 131	11 096	11 122	11 085	11 085
<b>ft/in</b>	<b>36'5"</b>	<b>36'6"</b>	<b>36'6"</b>	<b>36'5"</b>	<b>36'6"</b>	<b>36'5"</b>	<b>36'5"</b>
Tipping load straight* (\$) <b>kg</b>	55 216	54 526	54 184	53 745	54 784	51 692	53 325
<b>lb</b>	<b>121,730</b>	<b>120,209</b>	<b>119,455</b>	<b>118,487</b>	<b>120,778</b>	<b>113,961</b>	<b>117,561</b>
Static tipping load full 35° turn* (\$) <b>kg</b>	48 361	47 695	47 341	46 893	47 953	44 839	46 474
<b>lb</b>	<b>106,618</b>	<b>105,149</b>	<b>104,369</b>	<b>103,381</b>	<b>105,718</b>	<b>98,853</b>	<b>102,458</b>
Static tipping load full 40° turn* (\$) <b>kg</b>	46 440	45 780	45 422	44 972	46 037	42 919	44 554
<b>lb</b>	<b>102,383</b>	<b>100,928</b>	<b>100,138</b>	<b>99,146</b>	<b>101,494</b>	<b>94,620</b>	<b>98,225</b>
Static tipping load full 43° turn* (\$) <b>kg</b>	45 201	44 546	44 185	43 735	44 803	41 681	43 316
<b>lb</b>	<b>99,651</b>	<b>98,207</b>	<b>97,411</b>	<b>96,419</b>	<b>98,774</b>	<b>91,891</b>	<b>95,495</b>
Tipping load straight** (\$) <b>kg</b>	57 096	56 402	56 093	55 615	56 662	53 564	55 194
<b>lb</b>	<b>125,874</b>	<b>124,344</b>	<b>123,663</b>	<b>122,610</b>	<b>124,918</b>	<b>118,088</b>	<b>121,681</b>
Static tipping load full 35° turn** (\$) <b>kg</b>	51 328	50 653	50 338	49 847	50 913	47 796	49 426
<b>lb</b>	<b>113,158</b>	<b>111,671</b>	<b>110,976</b>	<b>109,893</b>	<b>112,244</b>	<b>105,372</b>	<b>108,965</b>
Static tipping load full 40° turn** (\$) <b>kg</b>	49 634	48 965	48 648	48 153	49 225	46 102	47 732
<b>lb</b>	<b>109,424</b>	<b>107,950</b>	<b>107,250</b>	<b>106,159</b>	<b>108,523</b>	<b>101,638</b>	<b>105,231</b>
Static tipping load full 43° turn** (\$) <b>kg</b>	48 527	47 863	47 544	47 047	48 123	44 996	46 625
<b>lb</b>	<b>106,984</b>	<b>105,519</b>	<b>104,817</b>	<b>103,720</b>	<b>106,092</b>	<b>99,198</b>	<b>102,791</b>
Breakout force*** (\$) <b>kg</b>	58 466	55 998	54 249	57 842	56 147	59 381	60 218
<b>lbf</b>	<b>128,894</b>	<b>123,454</b>	<b>119,599</b>	<b>127,519</b>	<b>123,782</b>	<b>130,913</b>	<b>132,758</b>
Operating weight*** (\$) <b>kg</b>	98 610	99 012	99 391	100 786	97 469	102 956	101 232
<b>lb</b>	<b>217,398</b>	<b>218,284</b>	<b>219,119</b>	<b>222,195</b>	<b>214,882</b>	<b>226,979</b>	<b>223,178</b>

\*Tipping loads were calculated within guidelines of ISO 14397-1:2007 to include tire squash (Tire pressure at 683 kPa [99 psi]).

\*\*Tipping load is calculated without tire squash.

\*\*\*Static tipping load and operating weight shown are based on standard machine configurations with a fuel tank, coolant, lubricants, and operator.

**NOTE:** Specifications and ratings conform to all applicable standards recommended by the Society for Automotive Engineers. SAE Standards J732C govern loader ratings and are denoted in the text by (\$).

Bucket Type		High Lift					
		Rock			Heavy Duty Rock		High Abrasion Rock
Ground Engaging Tools		Teeth & Segments	Teeth & Segments	Teeth & Segments	Teeth & Segments	Teeth & Segments	Teeth & Segments
Cutting Edge Type		Spade	Spade	Spade	Spade	Spade	Spade
Rated bucket capacity (§)	m <sup>3</sup>	10.7	11.5	12.3	10.7	11.5	10.7
	yd <sup>3</sup>	<b>14.0</b>	<b>15.0</b>	<b>16.0</b>	<b>14.0</b>	<b>15.0</b>	<b>14.0</b>
Operating load at rated capacity	kg	19 051	19 051	19 051	19 051	19 051	19 051
	lb	<b>42,000</b>	<b>42,000</b>	<b>42,000</b>	<b>42,000</b>	<b>42,000</b>	<b>42,000</b>
Struck capacity (§)	m <sup>3</sup>	8.9	9.5	10.2	8.9	9.5	8.9
	yd <sup>3</sup>	<b>11.6</b>	<b>12.4</b>	<b>13.3</b>	<b>11.6</b>	<b>12.4</b>	<b>11.6</b>
Bucket width (§)	mm	4824	4884	4824	4884	4824	4900
	ft/in	<b>15'10"</b>	<b>16'0"</b>	<b>15'10"</b>	<b>16'7"</b>	<b>15'10"</b>	<b>16'11"</b>
Dump clearance at full lift SAE 45° discharge (§)	Tooth tip mm	5224	5166	5112	5229	5162	5316
	ft/in	<b>17'2"</b>	<b>16'11"</b>	<b>16'9"</b>	<b>17'2"</b>	<b>16'11"</b>	<b>17'5"</b>
Reach at full lift SAE 45° discharge (§)	Tooth tip mm	2193	2246	2294	2189	2252	2159
	ft/in	<b>7'2"</b>	<b>7'4"</b>	<b>7'6"</b>	<b>7'2"</b>	<b>7'5"</b>	<b>7'1"</b>
Reach with boom horizontal and bucket level	mm	5504	5583	5655	5498	5590	5415
	ft/in	<b>18'1"</b>	<b>18'4"</b>	<b>18'7"</b>	<b>18'0"</b>	<b>18'4"</b>	<b>17'9"</b>
Digging depth (segment) (§)	mm	176	181	181	176	178	155
	in	<b>7.0</b>	<b>7.0</b>	<b>7.0</b>	<b>7.0</b>	<b>7.0</b>	<b>6.0</b>
Overall length — bucket level ground (§)	mm	16 197	16 279	16 351	16 191	16 284	16 095
	ft/in	<b>53'2"</b>	<b>53'5"</b>	<b>53'8"</b>	<b>53'1"</b>	<b>53'5"</b>	<b>52'10"</b>
Overall height with bucket at full raise (§)	mm	9930	9930	9930	9930	9930	9930
	ft/in	<b>32'7"</b>	<b>32'7"</b>	<b>32'7"</b>	<b>32'7"</b>	<b>32'7"</b>	<b>32'7"</b>
Loader clearance radius with bucket in carry position (§)	mm	11 326	11 352	11 349	11 324	11 352	11 313
	ft/in	<b>37'2"</b>	<b>37'3"</b>	<b>37'3"</b>	<b>37'2"</b>	<b>37'3"</b>	<b>37'1"</b>
Tipping load straight* (§)	kg	51 408	50 761	50 436	49 938	51 017	47 875
	lb	<b>113,335</b>	<b>111,909</b>	<b>111,192</b>	<b>110,094</b>	<b>112,473</b>	<b>105,546</b>
Static tipping load full 35° turn* (§)	kg	44 798	44 172	43 833	43 332	44 427	41 268
	lb	<b>98,763</b>	<b>97,382</b>	<b>96,635</b>	<b>95,531</b>	<b>97,945</b>	<b>90,980</b>
Static tipping load full 40° turn* (§)	kg	42 946	42 325	41 981	41 481	42 580	39 417
	lb	<b>94,680</b>	<b>93,311</b>	<b>92,552</b>	<b>91,450</b>	<b>93,873</b>	<b>86,900</b>
Static tipping load full 43° turn* (§)	kg	41 753	41 135	40 789	40 288	41 390	38 224
	lb	<b>92,049</b>	<b>90,687</b>	<b>89,924</b>	<b>88,820</b>	<b>91,249</b>	<b>84,269</b>
Tipping load straight** (§)	kg	53 044	52 396	52 099	51 567	52 653	49 505
	lb	<b>116,942</b>	<b>115,513</b>	<b>114,858</b>	<b>113,686</b>	<b>116,080</b>	<b>109,140</b>
Static tipping load full 35° turn** (§)	kg	47 472	46 840	46 535	45 994	47 097	43 932
	lb	<b>104,658</b>	<b>103,264</b>	<b>102,592</b>	<b>101,399</b>	<b>103,831</b>	<b>96,853</b>
Static tipping load full 40° turn** (§)	kg	45 835	45 209	44 901	44 358	45 466	42 296
	lb	<b>101,049</b>	<b>99,669</b>	<b>98,990</b>	<b>97,793</b>	<b>100,235</b>	<b>93,247</b>
Static tipping load full 43° turn** (§)	kg	44 766	44 143	43 834	43 289	44 400	41 227
	lb	<b>98,692</b>	<b>97,319</b>	<b>96,637</b>	<b>95,436</b>	<b>97,885</b>	<b>90,890</b>
Breakout force*** (§)	kg	57 948	55 495	53 760	57 324	55 656	58 856
	lbf	<b>127,753</b>	<b>122,345</b>	<b>118,520</b>	<b>126,378</b>	<b>122,700</b>	<b>129,755</b>
Operating weight*** (§)	kg	99 788	100 182	100 561	101 956	99 963	104 126
	lb	<b>219,995</b>	<b>220,863</b>	<b>221,699</b>	<b>224,774</b>	<b>220,380</b>	<b>229,558</b>

\*Tipping loads were calculated within guidelines of ISO 14397-1:2007 to include tire squash (Tire pressure at 683 kPa [99 psi]).

\*\*Tipping load is calculated without tire squash.

\*\*\*Static tipping load and operating weight shown are based on standard machine configurations with a fuel tank, coolant, lubricants, and operator.

**NOTE:** Specifications and ratings conform to all applicable standards recommended by the Society for Automotive Engineers. SAE Standards J732C govern loader ratings and are denoted in the text by (§).

Bucket Type		993K STD Tires: 50/65-51 Part No. 311-1938 SLR: 1461 mm							
		Rock						Coal	
Ground Engaging Tools		Teeth & Segments	Teeth & Segments	Teeth & Segments	Teeth & Segments	Teeth & Segments	Teeth & Segments	Teeth & Segments	
Cutting Edge Type		Spade	Spade	Spade	Spade	Spade	Spade	Straight	
Bucket Part Number — group level		303-3270	303-3310	303-3260	303-3330	303-3280	303-3290	310-8990	
Bucket load at rated capacity	kg	27 216	27 216	27 216	27 216	27 216	27 216	27 216	
	lb	<b>60,000</b>	<b>60,000</b>	<b>60,000</b>	<b>60,000</b>	<b>60,000</b>	<b>60,000</b>	<b>60,000</b>	
Rated capacity (\$)	m <sup>3</sup>	10.0	10.0	10.0	10.0	11.0	12.0	20.0	
	yd <sup>3</sup>	<b>13.1</b>	<b>13.1</b>	<b>13.1</b>	<b>13.1</b>	<b>14.4</b>	<b>15.7</b>	<b>26.2</b>	
Heaped capacity (\$)	m <sup>3</sup>	13.0	13.0	12.0	12.0	14.0	14.0	24.0	
	yd <sup>3</sup>	<b>17.0</b>	<b>17.0</b>	<b>15.7</b>	<b>15.7</b>	<b>18.3</b>	<b>18.3</b>	<b>31.4</b>	
Bucket width (\$)	mm	5080	5160	5080	5160	5080	5080	6300	
	ft	<b>16.7</b>	<b>16.9</b>	<b>16.7</b>	<b>16.9</b>	<b>16.7</b>	<b>16.7</b>	<b>20.7</b>	
Dump clearance at full lift and 45° discharge* (\$)	mm	4768	4835	4858	4883	4669	4669	4614	
	ft	<b>15.6</b>	<b>15.9</b>	<b>15.9</b>	<b>16.0</b>	<b>15.3</b>	<b>15.3</b>	<b>15.1</b>	
Reach at lift and 45° discharge*** (\$)	mm	2503	2507	2413	2459	2602	2602	2605	
	ft	<b>8.2</b>	<b>8.2</b>	<b>7.9</b>	<b>8.1</b>	<b>8.5</b>	<b>8.5</b>	<b>8.5</b>	
Reach with lift arms horizontal and bucket level* (\$)	mm	4922	4878	4794	4810	5062	5062	5103	
	ft	<b>16.1</b>	<b>16.0</b>	<b>15.7</b>	<b>15.8</b>	<b>16.6</b>	<b>16.6</b>	<b>16.7</b>	
Digging depth — segment (\$)	mm	132	117	132	117	132	132	154	
	in	<b>5.2</b>	<b>4.6</b>	<b>5.2</b>	<b>4.6</b>	<b>5.2</b>	<b>5.2</b>	<b>6.1</b>	
Overall length — bucket level ground	mm	15 124	15 068	14 996	15 000	15 264	15 264	15 323	
	ft	<b>49.6</b>	<b>49.4</b>	<b>49.2</b>	<b>49.2</b>	<b>50.1</b>	<b>50.1</b>	<b>50.3</b>	
Overall height with bucket at full raise	mm	9903	9876	9794	9794	9903	10 032	10 030	
	ft	<b>32.5</b>	<b>32.4</b>	<b>32.1</b>	<b>32.1</b>	<b>32.5</b>	<b>32.9</b>	<b>32.9</b>	
Loader clearance turning radius — SAE carry (\$)	mm	11 012	11 016	11 013	10 998	11 049	11 049	11 746	
	ft	<b>36.1</b>	<b>36.1</b>	<b>36.1</b>	<b>36.1</b>	<b>36.2</b>	<b>36.2</b>	<b>38.5</b>	
Full dump angle	degrees	-50	-50	-50	-50	-50	-50	-50	
Static tipping load straight # ** (\$)	kg	83 096	81 703	83 263	82 300	81 931	82 147	78 089	
	lb	<b>183,194</b>	<b>180,124</b>	<b>183,563</b>	<b>181,440</b>	<b>180,626</b>	<b>181,102</b>	<b>172,157</b>	
Static tipping load straight** (\$)	kg	79 105	77 736	79 312	78 354	77 962	78 114	73 991	
	lb	<b>174,396</b>	<b>171,378</b>	<b>174,853</b>	<b>172,741</b>	<b>171,877</b>	<b>172,212</b>	<b>163,122</b>	
Static tipping load — full turn (articulated 40 degrees) # ** (\$)	kg	71 976	70 608	72 159	71 193	70 886	71 056	67 100	
	lb	<b>158,680</b>	<b>155,664</b>	<b>159,084</b>	<b>156,953</b>	<b>156,276</b>	<b>156,651</b>	<b>147,930</b>	
Static tipping load — full turn (articulated 40 degrees)** (\$)	kg	64 192	62 859	64 431	63 471	63 141	63 220	59 190	
	lb	<b>141,519</b>	<b>138,580</b>	<b>142,046</b>	<b>139,929</b>	<b>139,202</b>	<b>139,376</b>	<b>130,491</b>	
Static tipping load — full turn (articulated 43 degrees) # ** (\$)	kg	70 327	68 963	70 513	69 546	69 248	69 411	65 470	
	lb	<b>155,045</b>	<b>152,037</b>	<b>155,454</b>	<b>153,322</b>	<b>152,665</b>	<b>153,025</b>	<b>144,337</b>	
Static tipping load — full turn (articulated 43 degrees)** (\$)	kg	61 906	62 065	63 762	63 342	59 853	59 704	56 337	
	lb	<b>136,479</b>	<b>136,830</b>	<b>140,571</b>	<b>139,645</b>	<b>131,953</b>	<b>131,625</b>	<b>124,202</b>	
Breakout force (\$)	kN	718	734	762	761	674	673	638	
	lbf	<b>161,390</b>	<b>165,010</b>	<b>171,372</b>	<b>171,035</b>	<b>151,499</b>	<b>151,252</b>	<b>143,361</b>	
Operating weight** (\$)	kg	132 251	133 234	131 988	132 788	132 702	132 877	135 859	
	lb	<b>291,564</b>	<b>293,731</b>	<b>290,984</b>	<b>292,748</b>	<b>292,558</b>	<b>292,944</b>	<b>299,518</b>	
Weight distribution at SAE carry — unloaded**	Front	kg	76 930	78 615	76 482	77 858	77 770	78 022	83 099
		lb	<b>169,601</b>	<b>173,315</b>	<b>168,614</b>	<b>171,647</b>	<b>171,453</b>	<b>172,008</b>	<b>183,203</b>
	Rear	kg	55 322	54 620	55 506	54 930	54 933	54 856	52 760
		lb	<b>121,963</b>	<b>120,416</b>	<b>122,370</b>	<b>121,101</b>	<b>121,105</b>	<b>120,936</b>	<b>116,316</b>
Weight distribution at SAE carry — loaded**	Front	kg	120 265	121 981	119 797	121 151	121 280	121 508	127 036
		lb	<b>265,139</b>	<b>268,922</b>	<b>264,106</b>	<b>267,091</b>	<b>267,377</b>	<b>267,880</b>	<b>280,065</b>
	Rear	kg	39 202	38 469	39 408	38 854	38 638	38 585	36 040
		lb	<b>86,426</b>	<b>84,810</b>	<b>86,879</b>	<b>85,658</b>	<b>85,182</b>	<b>85,065</b>	<b>79,454</b>

\*Dimensions are measured to the tip of the bucket teeth to provide accurate clearance data. SAE Standards specifies the cutting edge.

\*\*Static tipping load and operating weight shown are based on standard machine configuration with 50/65-51 tires, full fuel tank, coolant and lubricants.

\*\*\*Measured 102 mm (4") behind tip of cutting edge with bucket hinge pin as pivot point in accordance with SAE J732 JUN92.

#Tipping load is calculated without tire squash.

NOTE: Specifications and ratings conform to all applicable standards recommended by the Society of Automotive Engineers (SAE). SAE Standards J732 JUN92 and J742 FEB85 govern loader ratings denoted in text by (\$).

# Wheel Loaders Integrated Toolcarriers

## Performance Data ● 993K

Bucket Type		993K HL Tires: 50/65-51 Part No. 311-1938 SLR: 1461 mm							
		Rock						Coal	
Ground Engaging Tools		Teeth & Segments	Teeth & Segments	Teeth & Segments	Teeth & Segments	Teeth & Segments	Teeth & Segments	Teeth & Segments	
Cutting Edge Type		Spade	Spade	Spade	Spade	Spade	Spade	Straight	
Bucket Part Number — group level		303-3270	303-3310	303-3260	303-3330	303-3280	303-3290	310-8990	
Bucket load at rated capacity	kg	24 948	24 948	24 948	24 948	24 948	24 948	24 948	
	lb	<b>55,000</b>	<b>55,000</b>	<b>55,000</b>	<b>55,000</b>	<b>55,000</b>	<b>55,000</b>	<b>55,000</b>	
Rated capacity (\$)	m <sup>3</sup>	12.8	12.8	12.0	12.0	13.8	14.5	23.7	
	yd <sup>3</sup>	<b>16.7</b>	<b>16.7</b>	<b>15.7</b>	<b>15.7</b>	<b>18.0</b>	<b>19.0</b>	<b>31.0</b>	
Struck capacity (\$)	m <sup>3</sup>	10.0	10.0	10.0	10.0	11.0	12.0	20.0	
	yd <sup>3</sup>	<b>13.1</b>	<b>13.1</b>	<b>13.1</b>	<b>13.1</b>	<b>14.4</b>	<b>15.7</b>	<b>26.2</b>	
Heaped capacity (\$)	m <sup>3</sup>	13.0	13.0	12.0	12.0	14.0	14.0	24.0	
	yd <sup>3</sup>	<b>17.0</b>	<b>17.0</b>	<b>15.7</b>	<b>15.7</b>	<b>18.3</b>	<b>18.3</b>	<b>31.4</b>	
Bucket width (\$)	mm	5080	5160	5080	5160	5080	5080	6300	
	ft	<b>16.7</b>	<b>16.9</b>	<b>16.7</b>	<b>16.9</b>	<b>16.7</b>	<b>16.7</b>	<b>20.7</b>	
Dump clearance at full lift and 45° discharge* (\$)	mm	5413	5480	5503	5528	5314	5314	5259	
	ft	<b>17.8</b>	<b>18.0</b>	<b>18.1</b>	<b>18.1</b>	<b>17.4</b>	<b>17.4</b>	<b>17.3</b>	
Reach at lift and 45° discharge*** (\$)	mm	2612	2616	2522	2568	2711	2711	2714	
	ft	<b>8.6</b>	<b>8.6</b>	<b>8.3</b>	<b>8.4</b>	<b>8.9</b>	<b>8.9</b>	<b>8.9</b>	
Reach with lift arms horizontal and bucket level* (\$)	mm	5438	5394	5310	5326	5578	5578	5619	
	ft	<b>17.8</b>	<b>17.7</b>	<b>17.4</b>	<b>17.5</b>	<b>18.3</b>	<b>18.3</b>	<b>18.4</b>	
Digging depth (segment) (\$)	mm	199	184	199	184	199	199	221	
	in	<b>7.8</b>	<b>7.2</b>	<b>7.8</b>	<b>7.2</b>	<b>7.8</b>	<b>7.8</b>	<b>8.7</b>	
Overall length — bucket level ground	mm	5953.9	5898.8	5825.9	5830.8	6093.9	6093.9	6150.1	
	ft	<b>19.5</b>	<b>19.4</b>	<b>19.1</b>	<b>19.1</b>	<b>20.0</b>	<b>20.0</b>	<b>20.2</b>	
Overall height with bucket at full raise	mm	10 547	10 521	10 439	10 439	10 547	10 677	10 675	
	ft	<b>34.6</b>	<b>34.5</b>	<b>34.2</b>	<b>34.2</b>	<b>34.6</b>	<b>35.0</b>	<b>35.0</b>	
Loader clearance turning radius (SAE carry) (\$)	mm	11 308	11 311	11 309	11 292	11 348	11 348	12 043	
	ft	<b>37.1</b>	<b>37.1</b>	<b>37.1</b>	<b>37.0</b>	<b>37.2</b>	<b>37.2</b>	<b>39.5</b>	
Full dump angle	degrees	-50	-50	-50	-50	-50	-50	-50	
Static tipping load straight # ** (\$)	kg	69 659	68 341	69 856	68 908	68 656	68 775	64 946	
	lb	<b>153,571</b>	<b>150,665</b>	<b>154,006</b>	<b>151,916</b>	<b>151,360</b>	<b>151,624</b>	<b>143,182</b>	
Static tipping load straight** (\$)	kg	66 576	65 274	66 804	65 860	65 583	65 656	61 751	
	lb	<b>146,775</b>	<b>143,904</b>	<b>147,277</b>	<b>145,196</b>	<b>144,586</b>	<b>144,747</b>	<b>136,137</b>	
Static tipping load — full turn (articulated 40 degrees) # ** (\$)	kg	59 871	58 572	60 081	59 130	58 927	59 011	55 261	
	lb	<b>131,994</b>	<b>129,130</b>	<b>132,455</b>	<b>130,359</b>	<b>129,911</b>	<b>130,096</b>	<b>121,830</b>	
Static tipping load — full turn (articulated 40 degrees)** (\$)	kg	53 578	52 304	53 828	53 252	52 657	52 674	48 854	
	lb	<b>118,119</b>	<b>115,310</b>	<b>118,670</b>	<b>117,400</b>	<b>116,089</b>	<b>116,126</b>	<b>107,705</b>	
Static tipping load — full turn (articulated 43 degrees) # ** (\$)	kg	58 420	57 124	58 631	57 680	57 484	57 563	53 825	
	lb	<b>128,794</b>	<b>125,936</b>	<b>129,259</b>	<b>127,163</b>	<b>126,730</b>	<b>126,904</b>	<b>118,664</b>	
Static tipping load — full turn (articulated 43 degrees)** (\$)	kg	52 300	52 185	53 770	52 882	50 628	50 476	47 250	
	lb	<b>115,302</b>	<b>115,048</b>	<b>118,542</b>	<b>116,585</b>	<b>111,616</b>	<b>111,280</b>	<b>104,168</b>	
Breakout force (\$)	kN	717	733	761	760	673	672	637	
	lbf	<b>161,143</b>	<b>164,740</b>	<b>171,125</b>	<b>170,765</b>	<b>151,274</b>	<b>151,004</b>	<b>143,158</b>	
Operating weight** (\$)	kg	133 217	134 200	132 954	133 754	133 668	133 843	136 825	
	lb	<b>293,694</b>	<b>295,861</b>	<b>293,114</b>	<b>294,878</b>	<b>294,688</b>	<b>295,074</b>	<b>301,648</b>	
Weight distribution at SAE carry — unloaded**	Front	kg	81 114	82 919	80 637	82 111	82 005	82 276	87 684
		lb	<b>178,825</b>	<b>182,804</b>	<b>177,774</b>	<b>181,024</b>	<b>180,790</b>	<b>181,388</b>	<b>193,311</b>
	Rear	kg	52 104	51 282	52 317	51 643	51 663	51 567	49 141
		lb	<b>114,869</b>	<b>113,057</b>	<b>115,340</b>	<b>113,854</b>	<b>113,898</b>	<b>113,686</b>	<b>108,337</b>
Weight distribution at SAE carry — loaded**	Front	kg	123 719	125 558	123 225	124 686	124 768	125 014	130 818
		lb	<b>272,753</b>	<b>276,808</b>	<b>271,665</b>	<b>274,884</b>	<b>275,066</b>	<b>275,609</b>	<b>288,404</b>
	Rear	kg	34 446	33 590	34 677	34 017	33 848	33 777	30 956
		lb	<b>75,941</b>	<b>74,054</b>	<b>76,450</b>	<b>74,994</b>	<b>74,623</b>	<b>74,465</b>	<b>68,245</b>

\*Dimensions are measured to the tip of the bucket teeth to provide accurate clearance data. SAE Standards specifies the cutting edge.

\*\*Static tipping load and operating weight shown are based on standard machine configuration with 50/65-51 tires, full fuel tank, coolant and lubricants.

\*\*\*Measured 102 mm (4") behind tip of cutting edge with bucket hinge pin as pivot point in accordance with SAE J732 JUN92.

#Tipping load is calculated without tire squash.

**NOTE:** Specifications and ratings conform to all applicable standards recommended by the Society of Automotive Engineers (SAE). SAE Standards J732 JUN92 and J742 FEB85 govern loader ratings denoted in text by (\$).

993K Performance Conversion Table Based on Tire Selection

		50/65-51 (311-1938)	50/65R51 (311-2443)	50/65-51 (322-9665)	50/65R51 (311-2445)
Dump clearance at full lift and 45° discharge	mm	0	-51	0	-20
	ft	0	0	0	0
Reach at full lift and 45° discharge	mm	0	0	0	-2
	ft	0	0	0	0
Reach with lift arms horizontal and bucket level	mm	0	0	0	-2
	ft	0	0	0	0
Digging depth	mm	0	51	0	20
	ft	0	0	0	0
Overall length	mm	0	41	0	16
	ft	0	0	0	0
Overall height with bucket at full raise	mm	0	-51	0	-20
	ft	0	0	0	0
Total width (width over tires)	mm	0	18	0	13
	ft	0	0	0	0
Static tipping load straight (no tire squash)	kg	0	0	0	-583
	lb	0	0	0	-1285
Static tipping load straight (with tire squash)	kg	0	-850	0	-2319
	lb	0	-1874	0	-5113
Static tipping load — full turn (articulated 40°) (no tire squash)	kg	0	0	0	-515
	lb	0	0	0	-1135
Static tipping load — full turn (articulated 40°) (with tire squash)	kg	0	-1000	0	3398
	lb	0	-2205	0	-7491
Static tipping load — full turn (articulated 43°) (no tire squash)	kg	0	0	0	-505
	lb	0	0	0	-1113
Static tipping load — full turn (articulated 43°) (with tire squash)	kg	0	-730	0	-1774
	lb	0	-1609	0	-3911
Operating weight	kg	0	0	0	-760
	lb	0	0	0	-1676

NOTE: 50/65-51 used as baseline tire; 303-3280 bucket.

		<b>994K Standard Lift</b>			
<b>Bucket Type</b>		<b>Rock</b>			
<b>Ground Engaging Tools</b>		<b>Teeth &amp; Segments</b>	<b>Teeth &amp; Segments</b>	<b>Teeth &amp; Segments</b>	<b>Teeth &amp; Segments</b>
<b>Cutting Edge Type</b>		<b>Spade</b>	<b>Spade</b>	<b>Spade</b>	<b>Spade</b>
<b>Bucket Part Number – group level</b>		<b>389-4420</b>	<b>389-4430</b>	<b>389-4440</b>	<b>389-4450</b>
Bucket load at rated capacity	<b>kg</b>	40 823	40 823	40 823	40 823
	<b>lb</b>	<b>90,000</b>	<b>90,000</b>	<b>90,000</b>	<b>90,000</b>
Rated capacity	<b>m<sup>3</sup></b>	19.1	21.4	22.9	24.5
	<b>yd<sup>3</sup></b>	<b>25.0</b>	<b>28.0</b>	<b>30.0</b>	<b>32.0</b>
Struck capacity – ISO	<b>m<sup>3</sup></b>	15.0	18.0	19.0	20.0
	<b>yd<sup>3</sup></b>	<b>19.6</b>	<b>23.5</b>	<b>24.9</b>	<b>26.2</b>
Heaped capacity – ISO	<b>m<sup>3</sup></b>	19.0	21.0	23.0	24.0
	<b>yd<sup>3</sup></b>	<b>24.9</b>	<b>27.5</b>	<b>30.0</b>	<b>31.4</b>
Bucket width – overall	<b>mm</b>	6240	6240	6240	6240
	<b>ft</b>	<b>20.5</b>	<b>20.5</b>	<b>20.5</b>	<b>20.5</b>
Clearance at 45° dump (tooth tip)	<b>mm</b>	6347	6238	6167	6100
	<b>ft</b>	<b>20.8</b>	<b>20.5</b>	<b>20.2</b>	<b>20.0</b>
Reach at 45° dump (tooth tip)	<b>mm</b>	2641	2750	2821	2888
	<b>ft</b>	<b>8.7</b>	<b>9.0</b>	<b>9.3</b>	<b>9.5</b>
Bucket pin at maximum lift	<b>mm</b>	8790	8790	8790	8790
	<b>ft</b>	<b>28.8</b>	<b>28.8</b>	<b>28.8</b>	<b>28.8</b>
Horizontal arm and level bucket reach	<b>mm</b>	5583	5737	5837	5932
	<b>ft</b>	<b>18.3</b>	<b>18.8</b>	<b>19.1</b>	<b>19.5</b>
Digging depth (segment)	<b>mm</b>	232	232	232	232
	<b>in</b>	<b>0.8</b>	<b>0.8</b>	<b>0.8</b>	<b>0.8</b>
Overall length – bucket level ground	<b>mm</b>	17 606	17 760	17 860	17 955
	<b>ft</b>	<b>57.8</b>	<b>58.3</b>	<b>58.6</b>	<b>58.9</b>
Front axle to bucket tip ground	<b>mm</b>	6249	6403	6503	6598
	<b>ft</b>	<b>20.5</b>	<b>21.0</b>	<b>21.3</b>	<b>21.6</b>
Overall height	<b>mm</b>	11 541	11 688	11 771	11 874
	<b>ft</b>	<b>37.9</b>	<b>38.3</b>	<b>38.6</b>	<b>39.0</b>
Turning radius – corner SAE carry	<b>mm</b>	13 727	13 771	13 800	13 828
	<b>ft</b>	<b>45.0</b>	<b>45.2</b>	<b>45.3</b>	<b>45.4</b>
Reach at 45° dump and 2.13 m (7 ft) height (with teeth)	<b>mm</b>	4349	4454	4522	4585
	<b>ft</b>	<b>14.3</b>	<b>14.6</b>	<b>14.8</b>	<b>15.0</b>
Rack back angle at SAE carry	<b>degrees</b>	<b>47.7</b>	<b>47.7</b>	<b>47.7</b>	<b>47.7</b>
Full dump at maximum lift	<b>degrees</b>	<b>-50.0</b>	<b>-50.0</b>	<b>-50.0</b>	<b>-50.0</b>

		994K Standard Lift			
Bucket Type		Rock			
Ground Engaging Tools		Teeth & Segments	Teeth & Segments	Teeth & Segments	Teeth & Segments
Cutting Edge Type		Spade	Spade	Spade	Spade
Bucket Part Number – group level		389-4420	389-4430	389-4440	389-4450
Bucket load at rated capacity	kg	40 823	40 823	40 823	40 823
	lb	<b>90,000</b>	<b>90,000</b>	<b>90,000</b>	<b>90,000</b>
Rated capacity	m <sup>3</sup>	19.1	21.4	22.9	24.5
	yd <sup>3</sup>	<b>25.0</b>	<b>28.0</b>	<b>30.0</b>	<b>32.0</b>
Struck capacity – ISO	m <sup>3</sup>	15.0	18.0	19.0	20.0
	yd <sup>3</sup>	<b>19.6</b>	<b>23.5</b>	<b>24.9</b>	<b>26.2</b>
Heaped capacity – ISO	m <sup>3</sup>	19.0	21.0	23.0	24.0
	yd <sup>3</sup>	<b>24.9</b>	<b>27.5</b>	<b>30.0</b>	<b>31.4</b>
Tipping load at operating weight – straight	kg	159 823	158 190	157 062	156 085
	lb	<b>352,348</b>	<b>348,749</b>	<b>346,263</b>	<b>344,107</b>
Tipping load at operating weight – straight*	kg	150 697	149 006	147 840	146 825
	lb	<b>332,230</b>	<b>328,502</b>	<b>325,931</b>	<b>323,693</b>
Tipping load at operating weight – articulated 40°	kg	137 845	136 286	135 207	134 275
	lb	<b>303,896</b>	<b>300,459</b>	<b>298,081</b>	<b>296,025</b>
Tipping load at operating weight – articulated 40°*	kg	123 391	121 745	120 610	119 624
	lb	<b>272,030</b>	<b>268,401</b>	<b>265,899</b>	<b>263,725</b>
Tipping load at operating weight – bucket level ground	kg	135 113	130 634	127 808	125 353
	lb	<b>297,872</b>	<b>287,997</b>	<b>281,768</b>	<b>276,356</b>
Tipping load at operating weight – bucket level ground*	kg	126 010	121 984	119 430	117 209
	lb	<b>277,804</b>	<b>268,928</b>	<b>263,298</b>	<b>258,401</b>
Breakout force – SAE rated	kN	1401.1	1307.7	1252.7	1206.2
	lbf	<b>314,980</b>	<b>293,992</b>	<b>281,617</b>	<b>271,160</b>
Operating weight	kg	238 466	239 371	240 018	240 554
	lb	<b>525,727</b>	<b>527,723</b>	<b>529,149</b>	<b>530,329</b>
Weight distribution at SAE carry – front	kg	124 673	126 336	127 518	128 511
	lb	<b>274,858</b>	<b>278,522</b>	<b>281,129</b>	<b>283,319</b>
Weight distribution at SAE carry – rear	kg	113 792	113 036	112 500	112 042
	lb	<b>250,869</b>	<b>249,200</b>	<b>248,020</b>	<b>247,010</b>
Loaded machine weight	kg	279 289	280 194	280 841	281 377
	lb	<b>615,726</b>	<b>617,722</b>	<b>619,148</b>	<b>620,329</b>
Weight distribution at SAE carry – front	kg	192 099	193 989	195 324	196 461
	lb	<b>423,505</b>	<b>427,672</b>	<b>430,615</b>	<b>433,121</b>
Weight distribution at SAE carry – rear	kg	87 190	86 205	85 518	84 916
	lb	<b>192,220</b>	<b>190,050</b>	<b>188,534</b>	<b>187,208</b>

\*With tire squash.



		<b>994K High Lift</b>			
<b>Bucket Type</b>		<b>Rock</b>			
<b>Ground Engaging Tools</b>		<b>Teeth &amp; Segments</b>	<b>Teeth &amp; Segments</b>	<b>Teeth &amp; Segments</b>	<b>Teeth &amp; Segments</b>
<b>Cutting Edge Type</b>		<b>Spade</b>	<b>Spade</b>	<b>Spade</b>	<b>Spade</b>
<b>Bucket Part Number – group level</b>		<b>389-4420</b>	<b>389-4430</b>	<b>389-4440</b>	<b>389-4450</b>
Bucket load at rated capacity	<b>kg</b>	38 102	38 102	38 102	38 102
	<b>lb</b>	<b>84,000</b>	<b>84,000</b>	<b>84,000</b>	<b>84,000</b>
Rated capacity	<b>m<sup>3</sup></b>	19.1	21.4	22.9	24.5
	<b>yd<sup>3</sup></b>	<b>25.0</b>	<b>28.0</b>	<b>30.0</b>	<b>32.0</b>
Struck capacity – ISO	<b>m<sup>3</sup></b>	15.0	18.0	19.0	20.0
	<b>yd<sup>3</sup></b>	<b>19.6</b>	<b>23.5</b>	<b>24.9</b>	<b>26.2</b>
Heaped capacity – ISO	<b>m<sup>3</sup></b>	19.0	21.0	23.0	24.0
	<b>yd<sup>3</sup></b>	<b>24.9</b>	<b>27.5</b>	<b>30.0</b>	<b>31.4</b>
Bucket width – overall	<b>mm</b>	6240	6240	6240	6240
	<b>ft</b>	<b>20.5</b>	<b>20.5</b>	<b>20.5</b>	<b>20.5</b>
Clearance at 45° dump (tooth tip)	<b>mm</b>	7204	7095	7024	6957
	<b>ft</b>	<b>23.6</b>	<b>23.3</b>	<b>23.0</b>	<b>22.8</b>
Reach at 45° dump (tooth tip)	<b>mm</b>	2579	2688	2758	2826
	<b>ft</b>	<b>8.5</b>	<b>8.8</b>	<b>9.0</b>	<b>9.3</b>
Bucket pin at maximum lift	<b>mm</b>	9647	9647	9647	9647
	<b>ft</b>	<b>31.6</b>	<b>31.6</b>	<b>31.6</b>	<b>31.6</b>
Horizontal arm and level bucket reach	<b>mm</b>	6149	6303	6403	6498
	<b>ft</b>	<b>20.2</b>	<b>20.7</b>	<b>21.0</b>	<b>21.3</b>
Digging depth (segment)	<b>mm</b>	239	239	239	239
	<b>in</b>	<b>0.8</b>	<b>0.8</b>	<b>0.8</b>	<b>0.8</b>
Overall length – bucket level ground	<b>mm</b>	18 300	18 454	18 554	18 649
	<b>ft</b>	<b>60.0</b>	<b>60.5</b>	<b>60.9</b>	<b>61.2</b>
Front axle to bucket tip ground	<b>mm</b>	6943	7097	7197	7292
	<b>ft</b>	<b>22.8</b>	<b>23.3</b>	<b>23.6</b>	<b>23.9</b>
Overall height	<b>mm</b>	12 398	12 545	12 628	12 731
	<b>ft</b>	<b>40.7</b>	<b>41.2</b>	<b>41.4</b>	<b>41.8</b>
Turning radius – corner SAE carry	<b>mm</b>	13 976	14 017	14 045	14 071
	<b>ft</b>	<b>45.9</b>	<b>46.0</b>	<b>46.1</b>	<b>46.2</b>
Reach at 45° dump and 2.13 m (7 ft) height (with teeth)	<b>mm</b>	4916	5021	5088	5152
	<b>ft</b>	<b>16.1</b>	<b>16.5</b>	<b>16.7</b>	<b>16.9</b>
Rack back angle at SAE carry	<b>degrees</b>	<b>53.5</b>	<b>53.5</b>	<b>53.5</b>	<b>53.5</b>
Full dump at maximum lift	<b>degrees</b>	<b>-50.0</b>	<b>-50.0</b>	<b>-50.0</b>	<b>-50.0</b>

		994K High Lift			
Bucket Type		Rock			
Ground Engaging Tools		Teeth & Segments	Teeth & Segments	Teeth & Segments	Teeth & Segments
Cutting Edge Type		Spade	Spade	Spade	Spade
Bucket Part Number – group level		389-4420	389-4430	389-4440	389-4450
Bucket load at rated capacity	kg	40 823	40 823	40 823	40 823
	lb	90,000	90,000	90,000	90,000
Rated capacity	m <sup>3</sup>	19.1	21.4	22.9	24.5
	yd <sup>3</sup>	25.0	28.0	30.0	32.0
Struck capacity – ISO	m <sup>3</sup>	15.0	18.0	19.0	20.0
	yd <sup>3</sup>	19.6	23.5	24.9	26.2
Heaped capacity – ISO	m <sup>3</sup>	19.0	21.0	23.0	24.0
	yd <sup>3</sup>	24.9	27.5	30.0	31.4
Tipping load at operating weight – straight	kg	140 091	138 667	137 676	136 827
	lb	308,847	305,708	303,524	301,651
Tipping load at operating weight – straight*	kg	132 782	131 300	130 272	129 385
	lb	292,734	289,467	287,200	285,245
Tipping load at operating weight – articulated 40°	kg	120 292	118 917	117 960	117 141
	lb	265,198	262,168	260,057	258,251
Tipping load at operating weight – articulated 40°*	kg	108 277	106 814	105 800	104 925
	lb	238,710	235,484	233,249	231,320
Tipping load at operating weight – bucket level ground	kg	117 056	113 375	111 031	108 994
	lb	258,063	249,948	244,782	240,291
Tipping load at operating weight – bucket level ground*	kg	110 225	106 841	104 676	102 794
	lb	243,004	235,544	230,771	226,622
Breakout force – SAE rated	kN	1335.0	1245.6	1192.9	1148.3
	lbf	300,129	280,028	268,171	258,148
Operating weight	kg	239 693	240 598	241 245	241 781
	lb	528,432	530,428	531,854	533,034
Weight distribution at SAE carry – front	kg	129 194	130 922	132 151	133 180
	lb	284,823	288,633	291,343	293,611
Weight distribution at SAE carry – rear	kg	110 499	109 677	109 094	108 601
	lb	243,609	241,795	240,511	239,423
Loaded machine weight	kg	277 795	278 700	279 347	279 883
	lb	612,432	614,428	615,855	617,035
Weight distribution at SAE carry – front	kg	195 479	197 370	198 709	199 840
	lb	430,958	435,126	438,077	440,571
Weight distribution at SAE carry – rear	kg	82 315	81 330	80 639	80 043
	lb	181,474	179,302	177,777	176,464

\*With tire squash.

# Wheel Loaders Integrated Toolcarriers

## Machine Dimensions ● 903C2

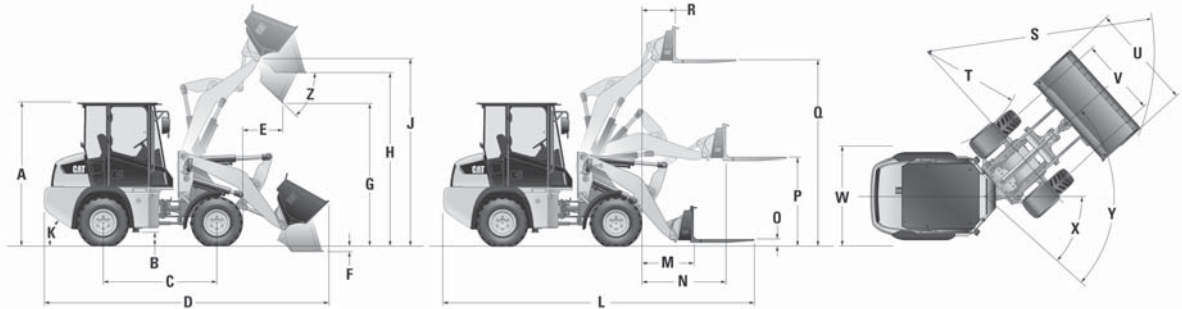

Dimensions listed are based on the machine configured with cab with air conditioning, quick coupler, general purpose bucket or 1067 mm (42 in) forks, 75 kg (165 lb) operator and 33 x 15.5-16.5, 12PR tires.

All dimensions are approximate.

MODEL	903C2 Standard		903C2 High Lift	
A Cab height	2510 mm	8'3"	2510 mm	8'3"
B Ground clearance	395 mm	1'4"	395 mm	1'4"
C Wheelbase	1800 mm	5'11"	1800 mm	5'11"
* D Overall length with bucket	4695 mm	15'5"	4860 mm	15'11"
* E Reach at maximum dump height	875 mm	2'10"	880 mm	2'11"
F Dig depth	200 mm	8"	200 mm	8"
* G Maximum dump height	2290 mm	8'0"	2430 mm	8'0"
H Load over height	2795 mm	9'2"	2940 mm	9'8"
J Hinge pin at maximum height	3080 mm	10'1"	3225 mm	10'7"
K Departure angle (degrees)		30°		30°
L Overall length with forks	5175 mm	17'0"	5330 mm	17'6"
M Reach at level ground	970 mm	3'2"	1130 mm	3'8"
N Maximum reach	1515 mm	5'0"	1635 mm	5'4"
O Fork depth above ground	40 mm	2"	40 mm	2"
P Fork height at maximum reach	1415 mm	4'8"	1415 mm	4'8"
Q Maximum fork height	3000 mm	10'2"	3140 mm	10'4"
R Fork reach at maximum height	750 mm	2'6"	755 mm	2'6"
* S Turning radius over bucket	3940 mm	13'1"	4020 mm	13'2"
** T Turning radius inside tire	1655 mm	5'5"	1655 mm	5'5"
* U Width over bucket	1770 mm	5'10"	1770 mm	5'10"
V Tire gauge	1314 mm	4'4"	1314 mm	4'4"
** W Machine width	1708 mm	5'7"	1708 mm	5'7"
X Articulation angle		40°		40°
Y Steering angle – left/right		80°		80°
Z Dump angle at maximum height		40°		40°

\*Vary with bucket size.

\*\*Vary with tire size.

Machine Dimensions  
 ● 906K/M, 907K/M, 908K/M  
 ● Horizontal Pin Coupler

Wheel Loaders  
 Integrated Toolcarriers

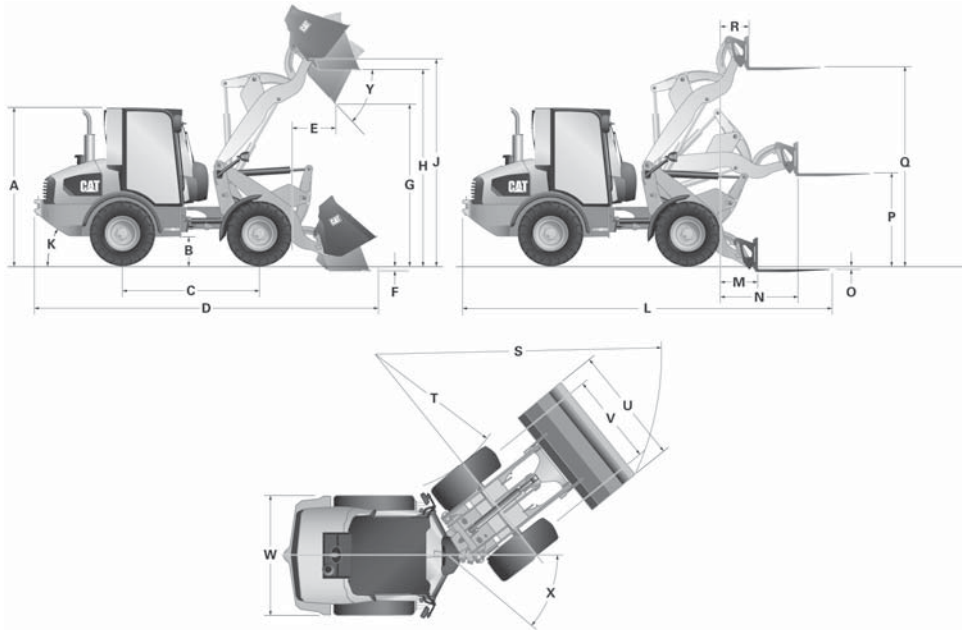

Dimensions shown are based on the machine equipped with general purpose bucket and standard 405/70 SPT9 tires.

All dimensions are approximate.

MODEL	906K/M		907K/M		908K/M	
A Cab height	2465 mm	8'1"	2585 mm	8'5"	2650 mm	8'8"
B Ground clearance	300 mm	12"	300 mm	12"	340 mm	1'1"
C Wheelbase	2170 mm	7'1"	2170 mm	7'1"	2170 mm	7'1"
D Overall length with bucket	5649 mm	17'11"	5649 mm	17'11"	5630 mm	18'5"
E Reach at maximum dump height	725 mm	2'4"	725 mm	2'4"	770 mm	2'6"
F Dig depth	95 mm	3.7"	95 mm	3.7"	101 mm	3.9"
G Maximum dump height	2478 mm	8'1"	2478 mm	8'1"	2620 mm	8'7"
H Load over height	3027 mm	9'11"	3027 mm	9'11"	3215 mm	10'7"
J Hinge pin at maximum height	3227 mm	10'7"	3227 mm	10'7"	3410 mm	11'2"
K Departure angle (degrees)	33°		33°		33°	
L Overall length with forks	5915 mm	19'4"	5915 mm	19'4"	6015 mm	19'8"
M Reach at ground level	720 mm	2'4"	720 mm	2'4"	790 mm	2'7"
N Maximum reach	1215 mm	3'11"	1215 mm	3'11"	1310 mm	4'3"
O Fork depth below ground (above ground)	25 mm	1"	25 mm	1"	70 mm	2.75"
P Fork height at maximum reach	1425 mm	4'8"	1425 mm	4'8"	1450 mm	4'9"
Q Maximum fork height	3090 mm	10'1"	3090 mm	10'1"	3225 mm	10'6"
R Fork reach at maximum height	445 mm	1'5"	445 mm	1'5"	460 mm	1'6"
S Turning radius over bucket	4400 mm	14'5"	4475 mm	14'8"	4530 mm	14'10"
T Turning radius inside tire	2240 mm	7'4"	2240 mm	7'4"	2080 mm	6'10"
U Width over bucket	1880 mm	6'2"	2035 mm	6'8"	2080 mm	6'10"
V Tire gauge	1420 mm	4'7"	1420 mm	4'7"	1570 mm	5'2"
W Machine width	1840 mm	6'0"	1840 mm	6'0"	1985 mm	6'6"
X Articulation angle (degrees)	39°		39°		39°	
Y Dump angle at maximum height (degrees)	45°		45°		45°	

# Wheel Loaders Integrated Toolcarriers

## Machine Dimensions

- 906K/M, 907K/M, 908K/M
- SSL Coupler

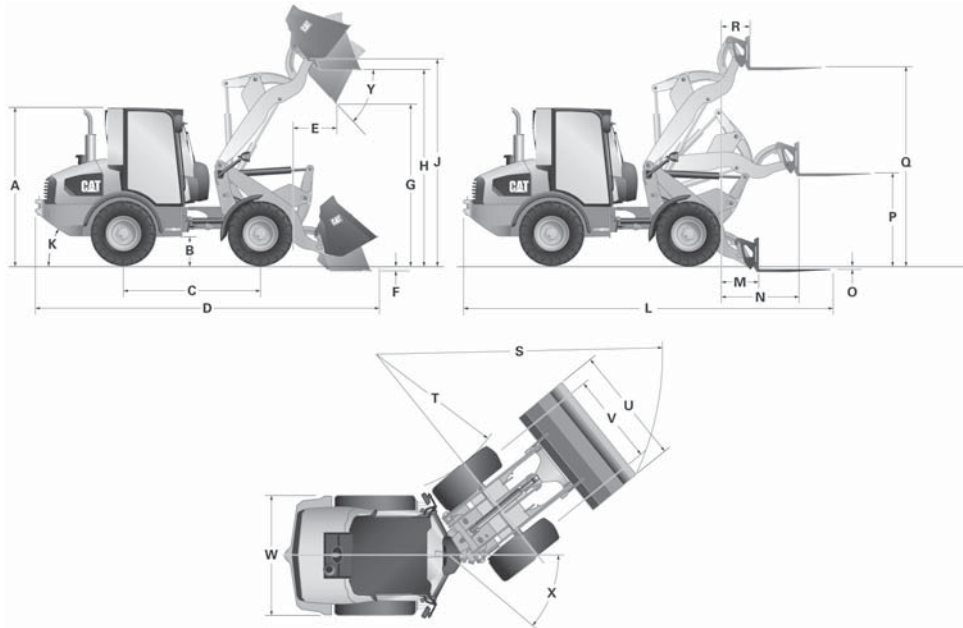

Dimensions shown are based on the machine equipped with general purpose bucket and standard 405/70 SPT9 tires.

All dimensions are approximate.

MODEL	906K/M		907K/M		908K/M	
A Cab height	2465 mm	8'1"	2585 mm	8'5"	2650 mm	8'8"
B Ground clearance	300 mm	11"	300 mm	11"	340 mm	1'1"
C Wheelbase	2170 mm	7'1"	2170 mm	7'1"	2170 mm	7'1"
D Overall length with bucket	5585 mm	18'3"	5585 mm	18'3"	5760 mm	18'10"
E Reach at maximum dump height	810 mm	2'7"	810 mm	2'7"	855 mm	2'9"
F Dig depth	90 mm	3.5"	90 mm	3.5"	95 mm	3.75"
G Maximum dump height	2395 mm	7'10"	2395 mm	7'10"	2540 mm	8'4"
H Load over height	3025 mm	9'11"	3025 mm	9'11"	3215 mm	10'7"
J Hinge pin at maximum height	3230 mm	10'7"	3230 mm	10'7"	3410 mm	11'2"
K Departure angle (degrees)	33°		33°		33°	
L Overall length with forks	5945 mm	19'6"	5945 mm	19'6"	6150 mm	20'2"
M Reach at ground level	750 mm	2'5"	750 mm	2'5"	925 mm	3'0"
N Maximum reach	1265 mm	4'1"	1265 mm	4'1"	1445 mm	4'8"
O Fork depth below ground (above ground)	(45 mm)	(1.75")	(45 mm)	(1.75")	(30 mm)	(1.15")
P Fork height at maximum reach	1490 mm	4'10"	1490 mm	4'10"	1525 mm	5'0"
Q Maximum fork height	3160 mm	10'4"	3160 mm	10'4"	3300 mm	10'9"
R Fork reach at maximum height	505 mm	1'7"	505 mm	1'7"	595 mm	1'11"
S Turning radius over bucket	4445 mm	14'7"	4515 mm	14'9"	4560 mm	15'0"
T Turning radius inside tire	2240 mm	7'4"	2240 mm	7'4"	2080 mm	6'10"
U Width over bucket	1880 mm	6'2"	2035 mm	6'8"	2060 mm	6'9"
V Tire gauge	1420 mm	4'7"	1420 mm	4'7"	1570 mm	5'2"
W Machine width	1840 mm	6'0"	1840 mm	6'0"	1985 mm	6'6"
X Articulation angle (degrees)	39°		39°		39°	
Y Dump angle at maximum height (degrees)	45°		45°		45°	

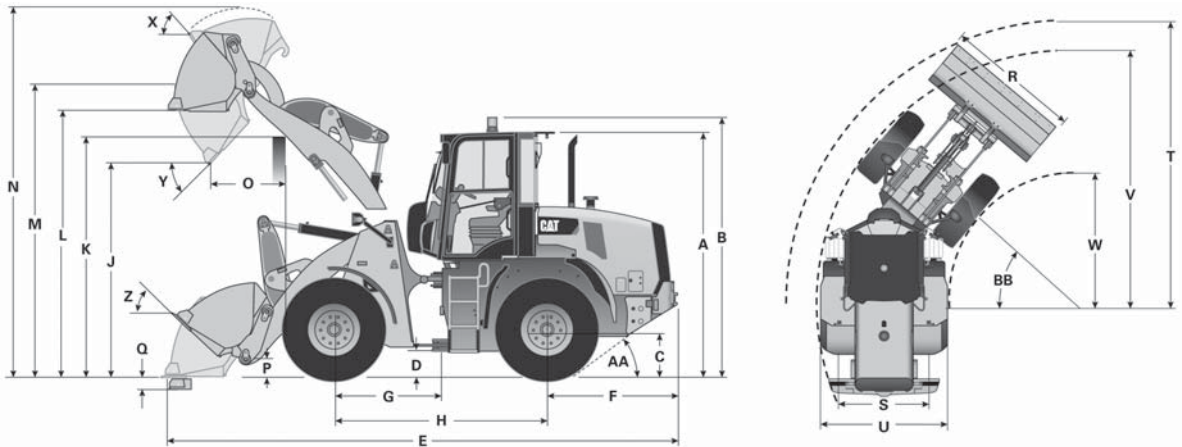

Dimensions listed are for a machine configured with general purpose pin on buckets, bolt-on cutting edges, full fuel tank, 80 kg (176 lb) operator, and standard tires.

All dimensions are approximate. Dimensions vary with bucket, couplers, and tire choice.

MODEL	910K Standard Lift and Pin On Bucket		910K High Lift and Pin On Bucket	
	** A Height: ground to cab	3020 mm	9'10"	3020 mm
** B Height: ground to beacon	3210 mm	10'6"	3210 mm	10'6"
** C Height: ground axle center	600 mm	1'11"	600 mm	1'11"
** D Height: ground clearance	348 mm	1'1"	348 mm	1'1"
* E Length: overall	6226 mm	20'5"	6758 mm	22'2"
F Length: rear axle to bumper	1590 mm	5'2"	1590 mm	5'2"
G Length: hitch to front axle	1300 mm	4'3"	1300 mm	4'3"
H Length: wheel base	2600 mm	8'6"	2600 mm	8'6"
* J Clearance: bucket at 45°	2846 mm	9'4"	3202 mm	10'6"
** K Clearance: load over height	3284 mm	10'9"	3397 mm	11'1"
** L Clearance: level bucket	3419 mm	11'2"	3775 mm	12'4"
** M Height: bucket pin	3673 mm	12'0"	4030 mm	13'2"
** N Height: overall	4534 mm	14'10"	4891 mm	16'0"
* O Reach: bucket at 45°	759 mm	2'5"	978 mm	3'2"
P Carry height: bucket pin	319 mm	1'0"	480 mm	1'6"
** Q Dig depth	116 mm	4.5"	294 mm	11.5"
R Width: bucket	2401 mm	7'10"	2401 mm	7'10"
S Width: tread center	1800 mm	5'10"	1800 mm	5'10"
T Turning radius: over bucket	5180 mm	16'11"	5419 mm	17'9"
U Width: over tires	2259 mm	7'4"	2259 mm	7'4"
V Turning radius: outside of tires	4783 mm	15'8"	4783 mm	15'8"
W Turning radius: inside of tires	2442 mm	8'0"	2442 mm	8'0"
X Rack angle at full lift		57°		59°
Y Dump angle at full lift		47°		43°
Z Rack angle at carry		42°		50°
AA Departure angle		33°		33°
BB Articulation angle		40°		40°
Operating weight	7130 kg	15,718 lb	7639 kg	16,837 lb

\*Varies with bucket.

\*\*Varies with tires.

# Wheel Loaders Integrated Toolcarriers

## Machine Dimensions ● 910K

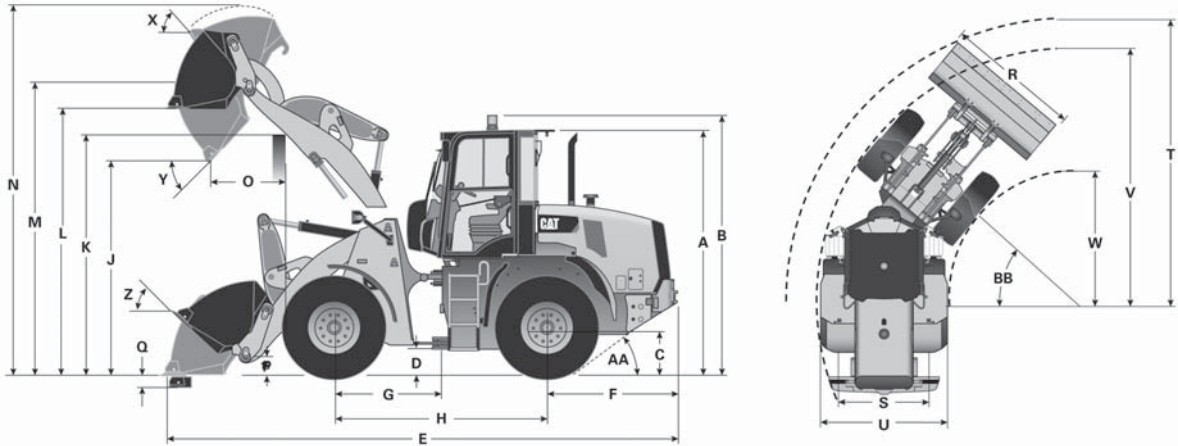

Dimensions listed are for a machine configured with general purpose pin on buckets, bolt-on cutting edges, full fuel tank, 80 kg (176 lb) operator, and standard tires.

All dimensions are approximate. Dimensions vary with bucket, couplers, and tire choice.

MODEL	910K		910K	
	Standard Lift and IT Bucket		High Lift and IT Bucket	
**A Height: ground to cab	3020 mm	9'10"	3020 mm	9'10"
**B Height: ground to beacon	3210 mm	10'6"	3210 mm	10'6"
**C Height: ground axle center	600 mm	1'11"	600 mm	1'11"
**D Height: ground clearance	348 mm	1'1"	348 mm	1'1"
*E Length: overall	6293 mm	20'7"	6825 mm	22'4"
F Length: rear axle to bumper	1590 mm	5'2"	1590 mm	5'2"
G Length: hitch to front axle	1300 mm	4'3"	1300 mm	4'3"
H Length: wheel base	2600 mm	8'6"	2600 mm	8'6"
*J Clearance: bucket at 45°	2809 mm	9'2"	3166 mm	10'4"
**K Clearance: load over height	3284 mm	10'9"	3397 mm	11'1"
**L Clearance: level bucket	3418 mm	11'2"	3774 mm	12'4"
**M Height: bucket pin	3673 mm	12'0"	4030 mm	13'2"
**N Height: overall	4563 mm	14'11"	4920 mm	16'1"
*O Reach: bucket at 45°	820 mm	2'8"	1039 mm	3'4"
P Carry height: bucket pin	319 mm	1'0"	480 mm	1'6"
**Q Dig depth	117 mm	4.5"	295 mm	11.6"
R Width: bucket	2401 mm	7'10"	2401 mm	7'10"
S Width: tread center	1800 mm	5'10"	1800 mm	5'10"
T Turning radius: over bucket	5200 mm	17'0"	5440 mm	17'10"
U Width: over tires	2259 mm	7'4"	2259 mm	7'4"
V Turning radius: outside of tires	4716 mm	15'5"	4783 mm	15'8"
W Turning radius: inside of tires	2442 mm	8'0"	2442 mm	8'0"
X Rack angle at full lift	57°		59°	
Y Dump angle at full lift	48°		44°	
Z Rack angle at carry	42°		50°	
AA Departure angle	33°		33°	
BB Articulation angle	40°		40°	
Operating weight	7470 kg	16,463 lb	7979 kg	17,586 lb

\*Varies with bucket.

\*\*Varies with tires.

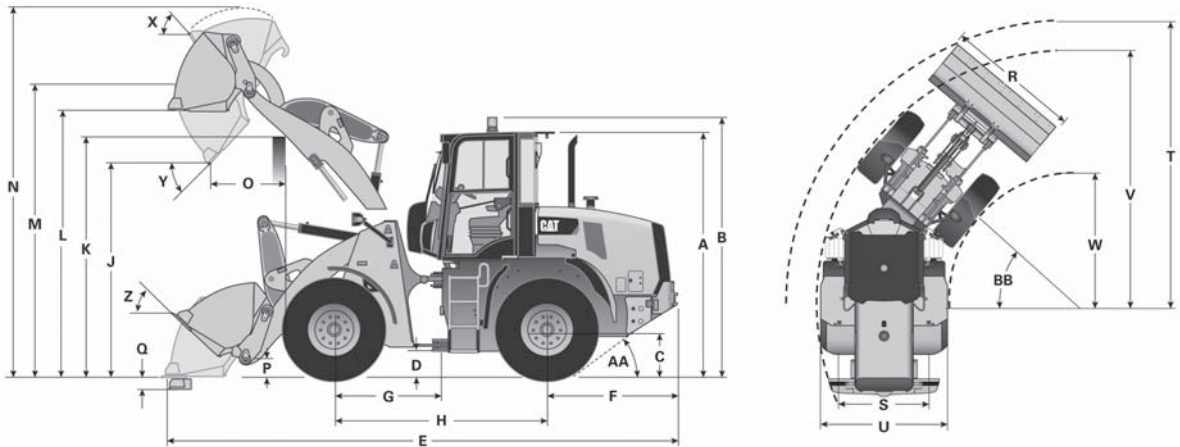

Dimensions listed are for a machine configured with general purpose pin on buckets, bolt-on cutting edges, full fuel tank, 80 kg (176 lb) operator, and standard tires.

All dimensions are approximate. Dimensions vary with bucket, couplers, and tire choice.

MODEL	914K Standard Lift and Pin On Bucket		914K High Lift and Pin On Bucket	
	** A Height: ground to cab	3093 mm	10'1"	3093 mm
** B Height: ground to beacon	3283 mm	10'9"	3283 mm	10'9"
** C Height: ground axle center	640 mm	2'1"	640 mm	2'1"
** D Height: ground clearance	405 mm	1'3"	405 mm	1'3"
* E Length: overall	6291 mm	20'7"	6834 mm	22'5"
F Length: rear axle to bumper	1600 mm	5'2"	1600 mm	5'2"
G Length: hitch to front axle	1300 mm	4'3"	1300 mm	4'3"
H Length: wheel base	2600 mm	8'6"	2600 mm	8'6"
* J Clearance: bucket at 45°	2820 mm	9'3"	3174 mm	10'4"
** K Clearance: load over height	3315 mm	10'10"	3429 mm	11'2"
** L Clearance: level bucket	3447 mm	11'3"	3800 mm	12'5"
** M Height: bucket pin	3701 mm	12'1"	4055 mm	13'3"
** N Height: overall	4621 mm	15'1"	4974 mm	16'3"
* O Reach: bucket at 45°	790 mm	2'7"	1009 mm	3'3"
P Carry height: bucket pin	317 mm	1'0"	483 mm	1'6"
** Q Dig depth	89 mm	3.4"	272 mm	10.7"
R Width: bucket	2401 mm	7'10"	2401 mm	7'10"
S Width: tread center	1800 mm	5'10"	1800 mm	5'10"
T Turning radius: over bucket	5200 mm	17'0"	5448 mm	17'10"
U Width: over tires	2259 mm	7'4"	2259 mm	7'4"
V Turning radius: outside of tires	4741 mm	15'6"	4741 mm	15'6"
W Turning radius: inside of tires	2426 mm	7'11"	2426 mm	7'11"
X Rack angle at full lift		57°		59°
Y Dump angle at full lift		48°		44°
Z Rack angle at carry		41°		49°
AA Departure angle		33°		33°
BB Articulation angle		40°		40°
Operating weight	8126 kg	17,910 lb	8181 kg	18,030 lb

\*Varies with bucket.

\*\*Varies with tires.



# Wheel Loaders Integrated Toolcarriers

## Machine Dimensions ● 914K

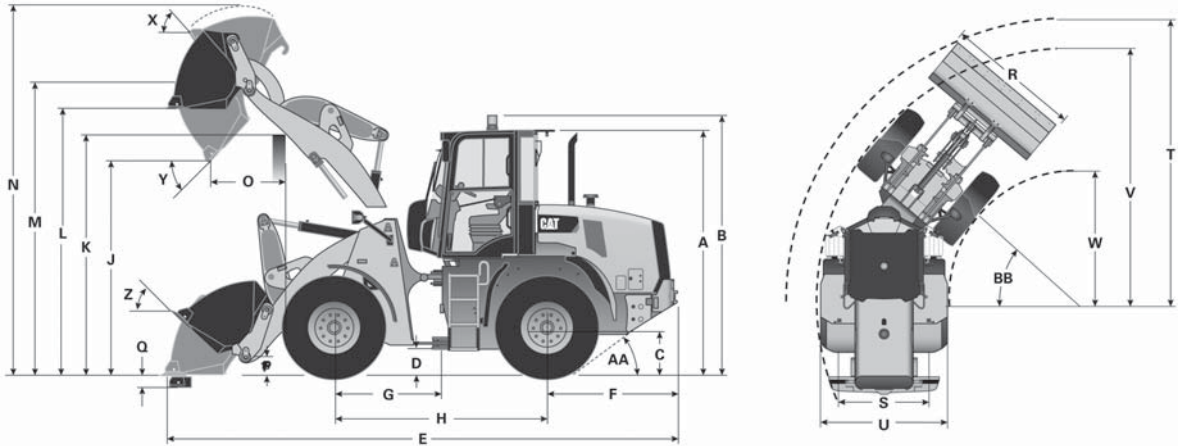

Dimensions listed are for a machine configured with general purpose pin on buckets, bolt-on cutting edges, full fuel tank, 80 kg (176 lb) operator, and standard tires.

All dimensions are approximate. Dimensions vary with bucket, couplers, and tire choice.

MODEL	914K		914K	
	Standard Lift and IT Bucket		High Lift and IT Bucket	
**A Height: ground to cab	3093 mm	10'1"	3093 mm	10'1"
**B Height: ground to beacon	3283 mm	10'9"	3283 mm	10'9"
**C Height: ground axle center	640 mm	2'1"	640 mm	2'1"
**D Height: ground clearance	405 mm	1'3"	405 mm	1'3"
*E Length: overall	6362 mm	20'10"	6905 mm	22'7"
F Length: rear axle to bumper	1600 mm	5'2"	1600 mm	5'2"
G Length: hitch to front axle	1300 mm	4'3"	1300 mm	4'3"
H Length: wheel base	2600 mm	8'6"	2600 mm	8'6"
*J Clearance: bucket at 45°	2775 mm	9'1"	3129 mm	10'3"
**K Clearance: load over height	3315 mm	10'10"	3429 mm	11'2"
**L Clearance: level bucket	3446 mm	11'3"	3800 mm	12'5"
**M Height: bucket pin	3701 mm	12'1"	4055 mm	13'3"
**N Height: overall	4674 mm	15'4"	5027 mm	16'5"
*O Reach: bucket at 45°	847 mm	2'9"	1066 mm	3'5"
P Carry height: bucket pin	317 mm	1'0"	483 mm	1'6"
**Q Dig depth	89 mm	3.5"	273 mm	10.7"
R Width: bucket	2401 mm	7'10"	2401 mm	7'10"
S Width: tread center	1800 mm	5'10"	1800 mm	5'10"
T Turning radius: over bucket	5222 mm	17'1"	5471 mm	17'11"
U Width: over tires	2259 mm	7'4"	2259 mm	7'4"
V Turning radius: outside of tires	4741 mm	15'6"	4741 mm	15'6"
W Turning radius: inside of tires	2426 mm	7'11"	2426 mm	7'11"
X Rack angle at full lift		57°		59°
Y Dump angle at full lift		48°		44°
Z Rack angle at carry		41°		49°
AA Departure angle		33°		33°
BB Articulation angle		40°		40°
Operating weight	8467 kg	18,666 lb	8521 kg	18,785 lb

\*Varies with bucket.

\*\*Varies with tires.

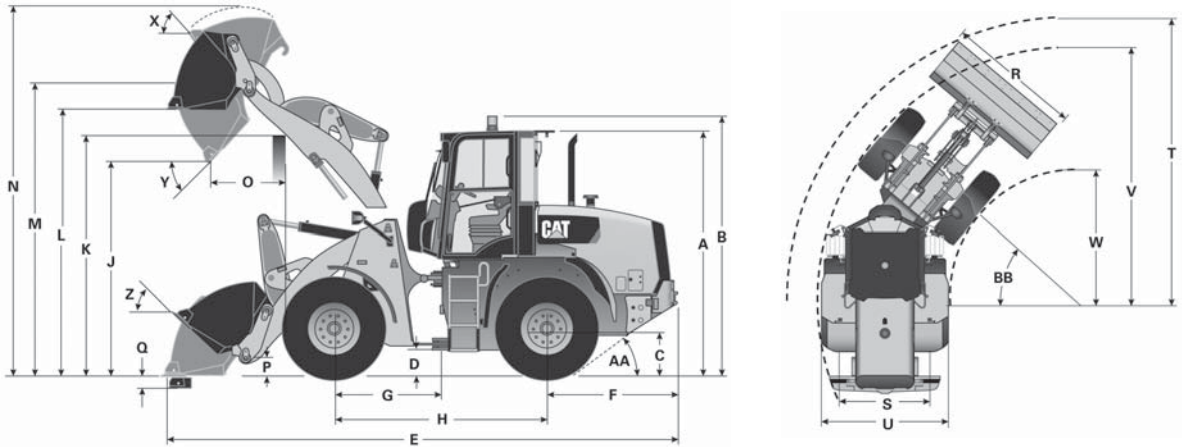

Dimensions listed are for a machine configured with general purpose buckets, bolt-on cutting edges, 80 kg (176 lb) operator and 15.5 R25 (L2) tires.

All dimensions are approximate. Dimensions vary with bucket and tire choice.

MODEL	910M Standard Lift – IT		910M Standard Lift – ISO		910M Standard Lift – PO	
	**A	3020 mm	9'10"	3020 mm	9'10"	3020 mm
**B	3210 mm	10'6"	3210 mm	10'6"	3210 mm	10'6"
**C	600 mm	1'11"	600 mm	1'11"	600 mm	1'11"
**D	348 mm	1'1"	348 mm	1'1"	348 mm	1'1"
*E	6293 mm	20'7"	6350 mm	20'10"	6226 mm	20'5"
F	1590 mm	5'2"	1590 mm	5'2"	1590 mm	5'2"
G	1300 mm	4'3"	1300 mm	4'3"	1300 mm	4'3"
H	2600 mm	8'6"	2600 mm	8'6"	2600 mm	8'6"
*J	2809 mm	9'2"	2772 mm	9'1"	2846 mm	9'4"
**K	3284 mm	10'9"	3284 mm	10'9"	3284 mm	10'9"
**L	3418 mm	11'2"	3418 mm	11'2"	3419 mm	11'2"
**M	3673 mm	12'0"	3673 mm	12'0"	3673 mm	12'0"
**N	4563 mm	14'11"	4599 mm	15'1"	4534 mm	14'10"
*O	820 mm	2'8"	863 mm	2'9"	759 mm	2'5"
P	319 mm	1'0"	317 mm	1'0"	319 mm	1'0"
**Q	117 mm	4.5"	117 mm	4.5"	116 mm	4.5"
R	2401 mm	7'10"	2401 mm	7'10"	2401 mm	7'10"
S	1800 mm	5'10"	1800 mm	5'10"	1800 mm	5'10"
T	5199 mm	17'0"	5216 mm	17'1"	5180 mm	16'11"
U	2259 mm	7'4"	2259 mm	7'4"	2259 mm	7'4"
V	4716 mm	15'5"	4716 mm	15'5"	4716 mm	15'5"
W	2446 mm	8'0"	2446 mm	8'0"	2446 mm	8'0"
X		57°		57°		57°
Y		48°		48°		47°
Z		42°		43°		42°
AA		33°		33°		33°
BB		40°		40°		40°
* Tipping load – straight (ISO 14397-1)	5991 kg	13,208 lb	5867 kg	12,935 lb	6066 kg	13,373 lb
* Tipping load – full turn (ISO 14397-1)	5062 kg	11,160 lb	4952 kg	10,917 lb	5152 kg	11,358 lb
* Breakout force	6458 kg	14,237 lb	6298 kg	13,885 lb	7339 kg	16,180 lb
* Operating weight	8090 kg	17,835 lb	8116 kg	17,893 lb	7734 kg	17,051 lb

\*Varies with bucket.

\*\*Varies with tires.

# Wheel Loaders Integrated Toolcarriers

## Machine Dimensions ● 910M

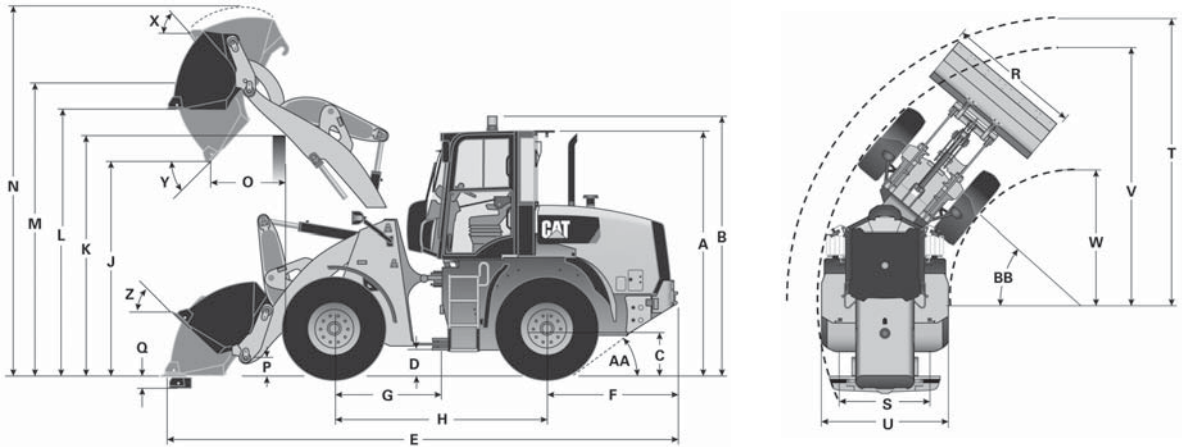

Dimensions listed are for a machine configured with general purpose buckets, bolt-on cutting edges, 80 kg (176 lb) operator and 15.5 R25 (L2) tires.

All dimensions are approximate. Dimensions vary with bucket and tire choice.

MODEL	910M		910M		910M	
	High Lift – IT		High Lift – ISO		High Lift – PO	
**A Height: ground to cab	3020 mm	9'10"	3020 mm	9'10"	3020 mm	9'10"
**B Height: ground to beacon	3210 mm	10'6"	3210 mm	10'6"	3210 mm	10'6"
**C Height: ground axle center	600 mm	1'11"	600 mm	1'11"	600 mm	1'11"
**D Height: ground clearance	348 mm	1'1"	348 mm	1'1"	348 mm	1'1"
*E Length: overall	6825 mm	22'4"	6882 mm	22'6"	6758 mm	22'2"
F Length: rear axle to bumper	1590 mm	5'2"	1590 mm	5'2"	1590 mm	5'2"
G Length: hitch to front axle	1300 mm	4'3"	1300 mm	4'3"	1300 mm	4'3"
H Length: wheel base	2600 mm	8'6"	2600 mm	8'6"	2600 mm	8'6"
*J Clearance: bucket at 45°	3176 mm	10'5"	3140 mm	10'3"	3219 mm	10'6"
**K Clearance: load over height	3397 mm	11'1"	3397 mm	11'1"	3397 mm	11'1"
**L Clearance: level bucket	3774 mm	12'4"	3774 mm	12'4"	3775 mm	12'4"
**M Height: bucket pin	4030 mm	13'2"	4030 mm	13'2"	4030 mm	13'2"
**N Height: overall	4920 mm	16'1"	4955 mm	16'3"	4891 mm	16'0"
*O Reach: bucket at 45°	1054 mm	3'5"	1100 mm	3'7"	1004 mm	3'3"
P Carry height: bucket pin	480 mm	1'6"	448 mm	1'5"	480 mm	1'6"
**Q Dig depth	295 mm	11.6"	295 mm	11.6"	294 mm	11.5"
R Width: bucket	2401 mm	7'10"	2401 mm	7'10"	2401 mm	7'10"
S Width: tread center	1800 mm	5'10"	1800 mm	5'10"	1800 mm	5'10"
T Turning radius: over bucket	5440 mm	17'10"	5452 mm	17'10"	5419 mm	17'9"
U Width: over tires	2259 mm	7'4"	2259 mm	7'4"	2259 mm	7'4"
V Turning radius: outside of tires	4716 mm	15'5"	4716 mm	15'5"	4716 mm	15'5"
W Turning radius: inside of tires	2446 mm	8'0"	2446 mm	8'0"	2446 mm	8'0"
X Rack angle at full lift		59°		60°		59°
Y Dump angle at full lift		44°		44°		43°
Z Rack angle at carry		50°		49°		50°
AA Departure angle		33°		33°		33°
BB Articulation angle		40°		40°		40°
* Tipping load – straight (ISO 14397-1)	5625 kg	12,401 lb	5524 kg	12,178 lb	5705 kg	12,577 lb
* Tipping load – full turn (ISO 14397-1)	4709 kg	10,382 lb	4619 kg	10,183 lb	4802 kg	10,587 lb
* Breakout force	6514 kg	14,361 lb	6351 kg	14,002 lb	7404 kg	16,323 lb
* Operating weight	8654 kg	19,079 lb	8680 kg	19,137 lb	8299 kg	18,296 lb

\*Varies with bucket.

\*\*Varies with tires.

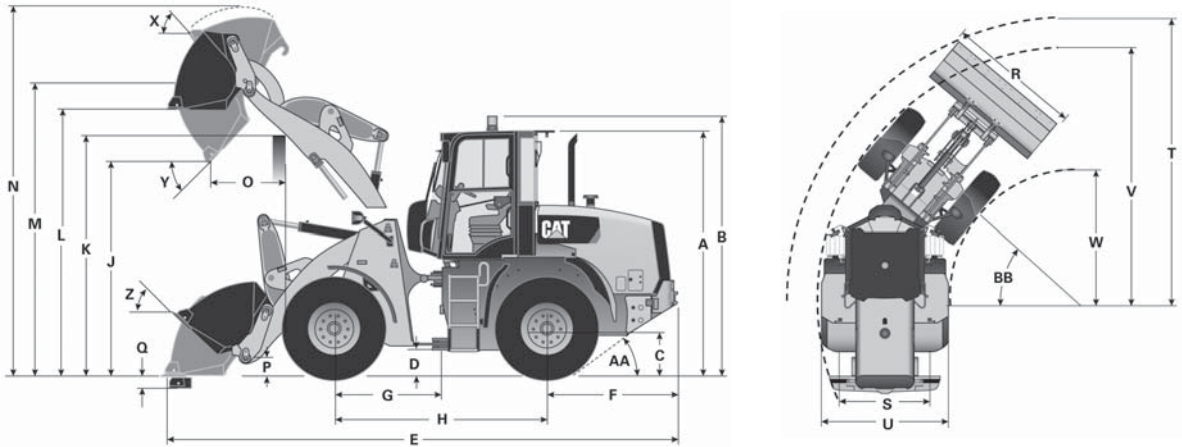

Dimensions listed are for a machine configured with general purpose IT buckets, bolt-on cutting edges, 80 kg (176 lb) operator and 17.5 R25 (L2) tires.

All dimensions are approximate. Dimensions vary with bucket and tire choice.

MODEL	914M Standard Lift – IT		914M Standard Lift – ISO		914M Standard Lift – PO	
	**A	3093 mm	10'1"	3093 mm	10'1"	3093 mm
**B	3283 mm	10'9"	3283 mm	10'9"	3283 mm	10'9"
**C	640 mm	2'1"	640 mm	2'1"	640 mm	2'1"
**D	405 mm	1'3"	405 mm	1'3"	405 mm	1'3"
*E	6362 mm	20'10"	6419 mm	21'0"	6291 mm	20'7"
F	1600 mm	5'2"	1600 mm	5'2"	1600 mm	5'2"
G	1300 mm	4'3"	1300 mm	4'3"	1300 mm	4'3"
H	2600 mm	8'6"	2600 mm	8'6"	2600 mm	8'6"
*J	2775 mm	9'1"	2738 mm	8'11"	2820 mm	9'3"
**K	3315 mm	10'10"	3315 mm	10'10"	3315 mm	10'10"
**L	3446 mm	11'3"	3446 mm	11'3"	3447 mm	11'3"
**M	3701 mm	12'1"	3701 mm	12'1"	3701 mm	12'1"
**N	4674 mm	15'4"	4695 mm	15'4"	4621 mm	15'1"
*O	847 mm	2'9"	889 mm	2'10"	790 mm	2'7"
P	317 mm	1'0"	322 mm	1'0"	317 mm	1'0"
**Q	89 mm	3.5"	90 mm	3.5"	89 mm	3.4"
R	2401 mm	7'10"	2401 mm	7'10"	2401 mm	7'10"
S	1800 mm	5'10"	1800 mm	5'10"	1800 mm	5'10"
T	5222 mm	17'1"	5240 mm	17'2"	5200 mm	17'0"
U	2259 mm	7'4"	2259 mm	7'4"	2259 mm	7'4"
V	4741 mm	15'6"	4741 mm	15'6"	4741 mm	15'6"
W	2426 mm	8'0"	2426 mm	8'0"	2426 mm	8'0"
X		57°		57°		57°
Y		48°		48°		48°
Z		41°		41°		41°
AA		33°		33°		33°
BB		40°		40°		40°
* Tipping load – straight (ISO 14397-1)	6387 kg	14,081 lb	6242 kg	13,761 lb	6546 kg	14,431 lb
* Tipping load – full turn (ISO 14397-1)	5374 kg	11,848 lb	5247 kg	11,568 lb	5539 kg	12,211 lb
* Breakout force	7357 kg	16,219 lb	6924 kg	15,265 lb	8730 kg	19,246 lb
* Operating weight	8740 kg	19,268 lb	8761 kg	19,315 lb	8360 kg	18,431 lb

\*Varies with bucket.

\*\*Varies with tires.

# Wheel Loaders Integrated Toolcarriers

## Machine Dimensions ● 914M

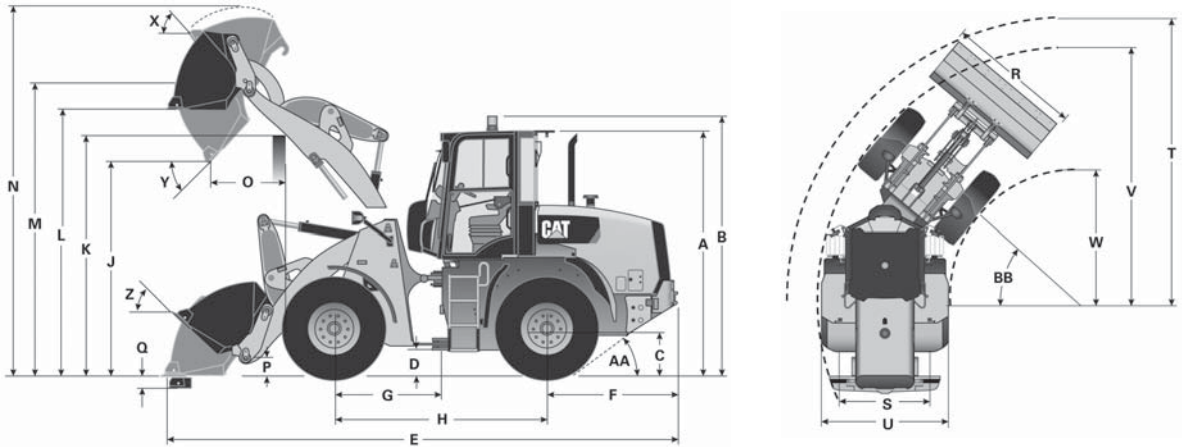

Dimensions listed are for a machine configured with general purpose IT buckets, bolt-on cutting edges, 80 kg (176 lb) operator and 17.5 R25 (L2) tires.

All dimensions are approximate. Dimensions vary with bucket and tire choice.

MODEL	914M High Lift – IT		914M High Lift – ISO		914M High Lift – PO		
	**A	Height: ground to cab	3093 mm	10'1"	3093 mm	10'1"	3093 mm
**B	Height: ground to beacon	3283 mm	10'9"	3283 mm	10'9"	3283 mm	10'9"
**C	Height: ground axle center	640 mm	2'1"	640 mm	2'1"	640 mm	2'1"
**D	Height: ground clearance	405 mm	1'3"	405 mm	1'3"	405 mm	1'3"
*E	Length: overall	6905 mm	22'7"	6962 mm	22'10"	6834 mm	22'5"
F	Length: rear axle to bumper	1600 mm	5'2"	1600 mm	5'2"	1600 mm	5'2"
G	Length: hitch to front axle	1300 mm	4'3"	1300 mm	4'3"	1300 mm	4'3"
H	Length: wheel base	2600 mm	8'6"	2600 mm	8'6"	2600 mm	8'6"
*J	Clearance: bucket at 45°	3141 mm	10'3"	3105 mm	10'2"	3188 mm	10'5"
**K	Clearance: load over height	3429 mm	11'2"	3429 mm	11'2"	3429 mm	11'2"
**L	Clearance: level bucket	3800 mm	12'5"	3799 mm	12'5"	3800 mm	12'5"
**M	Height: bucket pin	4055 mm	13'3"	4055 mm	13'3"	4055 mm	13'3"
**N	Height: overall	5027 mm	16'5"	5048 mm	16'6"	4974 mm	16'3"
*O	Reach: bucket at 45°	1083 mm	3'6"	1127 mm	3'8"	1029 mm	3'4"
P	Carry height: bucket pin	483 mm	1'6"	455 mm	1'5"	483 mm	1'6"
**Q	Dig depth	273 mm	10.7"	273 mm	10.7"	272 mm	10.7"
R	Width: bucket	2401 mm	7'10"	2401 mm	7'10"	2401 mm	7'10"
S	Width: tread center	1800 mm	5'10"	1800 mm	5'10"	1800 mm	5'10"
T	Turning radius: over bucket	5471 mm	17'11"	5484 mm	17'11"	5448 mm	17'10"
U	Width: over tires	2259 mm	7'4"	2259 mm	7'4"	2259 mm	7'4"
V	Turning radius: outside of tires	4741 mm	15'6"	4741 mm	15'6"	4741 mm	15'6"
W	Turning radius: inside of tires	2426 mm	8'0"	2426 mm	8'0"	2426 mm	8'0"
X	Rack angle at full lift		59°		59°		59°
Y	Dump angle at full lift		44°		44°		44°
Z	Rack angle at carry		49°		48°		49°
AA	Departure angle		33°		33°		33°
BB	Articulation angle		40°		40°		40°
	* Tipping load – straight (ISO 14397-1)	5656 kg	12,469 lb	5547 kg	12,229 lb	6025 kg	13,283 lb
	* Tipping load – full turn (ISO 14397-1)	4722 kg	10,410 lb	4626 kg	10,199 lb	5060 kg	11,155 lb
	* Breakout force	7466 kg	16,460 lb	7024 kg	15,485 lb	8861 kg	19,535 lb
	* Operating weight	9114 kg	20,093 lb	9135 kg	20,140 lb	8887 kg	19,592 lb

\*Varies with bucket.

\*\*Varies with tires.

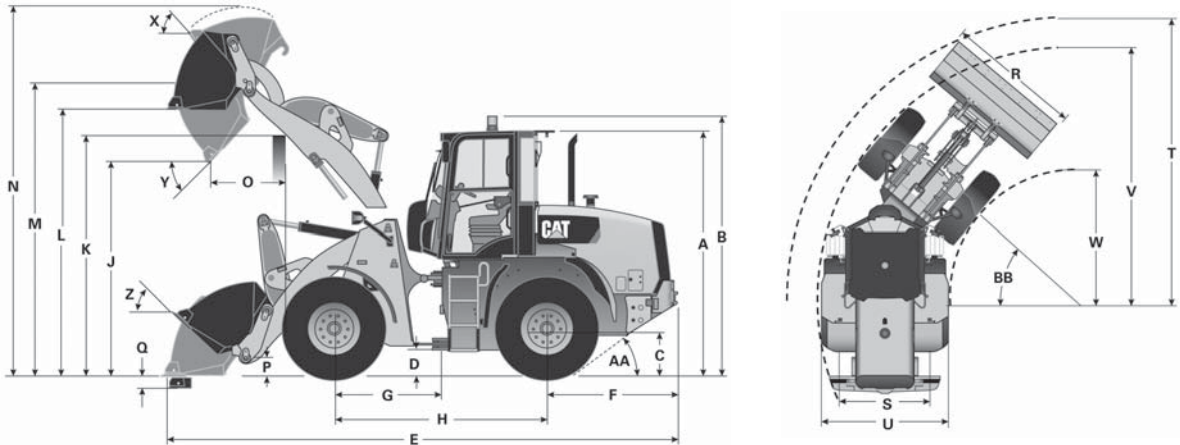

Dimensions listed are for a machine configured with general purpose bucket, bolt-on cutting edges, 80 kg (176 lb) operator, and 17.5 R25 (L2) tires.

All dimensions are approximate. Dimensions vary with bucket and tire choice.

MODEL	918M Standard Lift – IT		918M Standard Lift – ISO		918M Standard Lift – PO	
	**A	3110 mm	10'2"	3110 mm	10'2"	3110 mm
**B	3300 mm	10'9"	3300 mm	10'9"	3300 mm	10'9"
**C	640 mm	2'1"	640 mm	2'1"	640 mm	2'1"
**D	438 mm	1'5"	438 mm	1'5"	438 mm	1'5"
*E	6652 mm	21'9"	6708 mm	22'0"	6583 mm	21'7"
F	1615 mm	5'3"	1615 mm	5'3"	1615 mm	5'3"
G	1350 mm	4'5"	1350 mm	4'5"	1350 mm	4'5"
H	2700 mm	8'10"	2700 mm	8'10"	2700 mm	8'10"
*J	2838 mm	9'3"	2800 mm	9'2"	2882 mm	9'5"
**K	3381 mm	11'1"	3381 mm	11'1"	3381 mm	11'1"
**L	3562 mm	11'8"	3562 mm	11'8"	3563 mm	11'8"
**M	3818 mm	12'6"	3818 mm	12'6"	3818 mm	12'6"
**N	4847 mm	15'10"	4882 mm	16'0"	4825 mm	15'9"
*O	933 mm	3'0"	974 mm	3'2"	881 mm	2'10"
P	353 mm	1'1"	345 mm	1'1"	353 mm	1'1"
**Q	61 mm	2.4"	61 mm	2.4"	60 mm	2.3"
R	2401 mm	7'10"	2401 mm	7'10"	2401 mm	7'10"
S	1800 mm	5'10"	1800 mm	5'10"	1800 mm	5'10"
T	5410 mm	17'8"	5425 mm	17'9"	5390 mm	17'8"
U	2259 mm	7'4"	2259 mm	7'4"	2259 mm	7'4"
V	4877 mm	16'0"	4877 mm	16'0"	4877 mm	16'0"
W	2563 mm	8'5"	2563 mm	8'5"	2563 mm	8'5"
X		55°		55°		55°
Y		47°		47°		47°
Z		44°		44°		44°
AA		33°		33°		33°
BB		40°		40°		40°
* Tipping load – straight (ISO 14397-1)	6903 kg	15,219 lb	6740 kg	14,859 lb	7272 kg	16,032 lb
* Tipping load – full turn (ISO 14397-1)	5825 kg	12,837 lb	5681 kg	12,524 lb	6157 kg	13,574 lb
* Breakout force	8480 kg	18,695 lb	7933 kg	17,489 lb	9113 kg	20,091 lb
* Operating weight	9469 kg	20,876 lb	9491 kg	20,924 lb	9282 kg	20,463 lb

\*Varies with bucket.

\*\*Varies with tires.

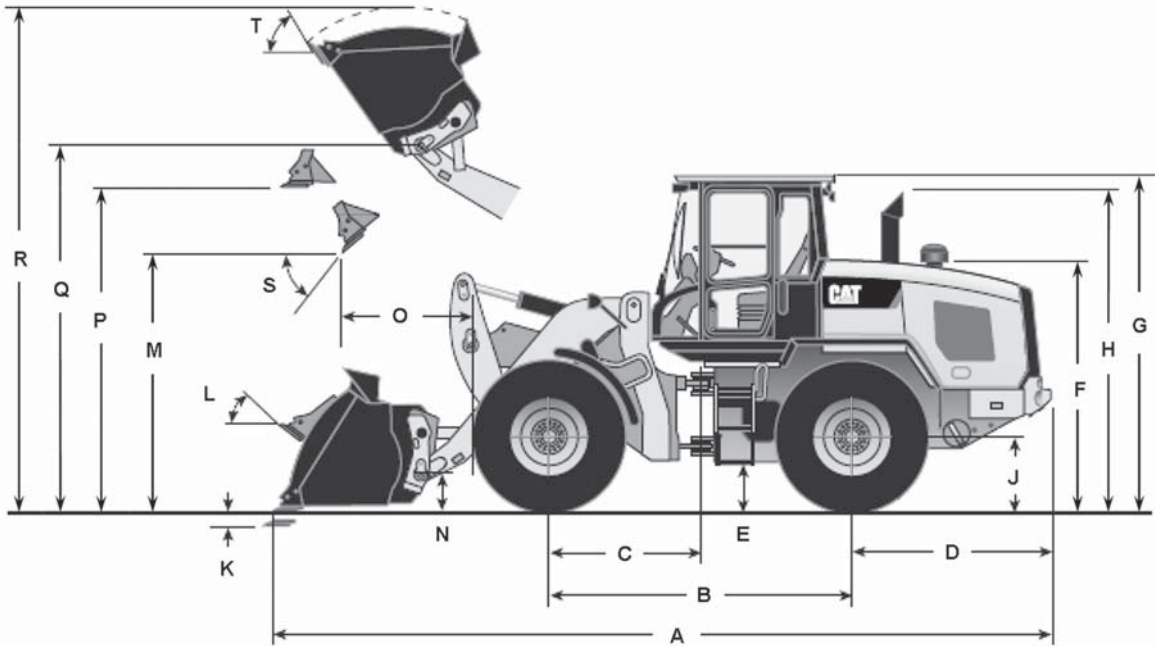

Dimensions listed are for a machine configured with Fusion general purpose bucket, bolt-on cutting edge, standard counterweight (924K), heavy counterweight (930K), additional guarding, 80 kg (176 lb) operator, and Michelin 20.5 R25 (L-3) XHA2 tires.

MODEL	926M*		926M*		930M*	
	Standard	High Lift	Standard	High Lift	Standard	High Lift
Bucket	1.9 m <sup>3</sup>	2.5 yd <sup>3</sup>	1.9 m <sup>3</sup>	2.5 yd <sup>3</sup>	2.1 m <sup>3</sup>	2.8 yd <sup>3</sup>
A Maximum overall length**	7451 mm	24'5"	8093 mm	26'7"	7530 mm	24'8"
B Wheel base	3000 mm	9'10"	3000 mm	9'10"	3000 mm	9'10"
C Machine center point to front axle	1500 mm	4'11"	1500 mm	4'11"	1500 mm	4'11"
D Rear axle to counterweight	1986 mm	6'6"	1986 mm	6'6"	1993 mm	6'6"
E Ground clearance***	397 mm	1'3"	397 mm	1'3"	397 mm	1'3"
F Height to top of engine compartment	2235 mm	7'4"	2235 mm	7'4"	2235 mm	7'4"
G Height to top of ROPS***	3340 mm	10'11"	3340 mm	10'11"	3340 mm	10'11"
H Height to top of stack	3223 mm	10'7"	3223 mm	10'7"	3223 mm	10'7"
J Tire Radius (empty machine)***	685 mm	2'3"	685 mm	2'3"	685 mm	2'3"
K Maximum digging depth (bucket level)***	100 mm	4"	135 mm	5"	100 mm	4"
L Maximum rollback at carry height	45°		49°		45°	
M Dump clearance at full lift and 45° discharge angle**	2885 mm	9'5"	3378 mm	11'0"	2828 mm	9'3"
N Hinge pin height at carry position	458 mm	1'6"	649 mm	2'2"	458 mm	1'6"
O Reach at full lift and 45° dump**	1024 mm	3'4"	1261 mm	4'1"	1064 mm	3'5"
P Clearance level bucket at full height***	3580 mm	11'9"	4073 mm	13'4"	3580 mm	11'9"
Q Maximum hinge pin height***	3907 mm	12'10"	4400 mm	14'5"	3907 mm	12'10"
R Maximum overall height***	5076 mm	16'7"	5569 mm	18'3"	5147 mm	16'10"
S Full dump at maximum lift	50°		49°		49°	
T Maximum roll back at maximum lift	54°		51°		54°	
Tires	20.5 R25 (L-3) XHA2		20.5 R25 (L-3) XHA2		20.5 R25 (L-3) XHA2	

\*Meets Tier 4 Final/Stage IV/Japan 2014 (Tier 4 Final) emission standards.

\*\*Varies with bucket.

\*\*\*Varies with tire.

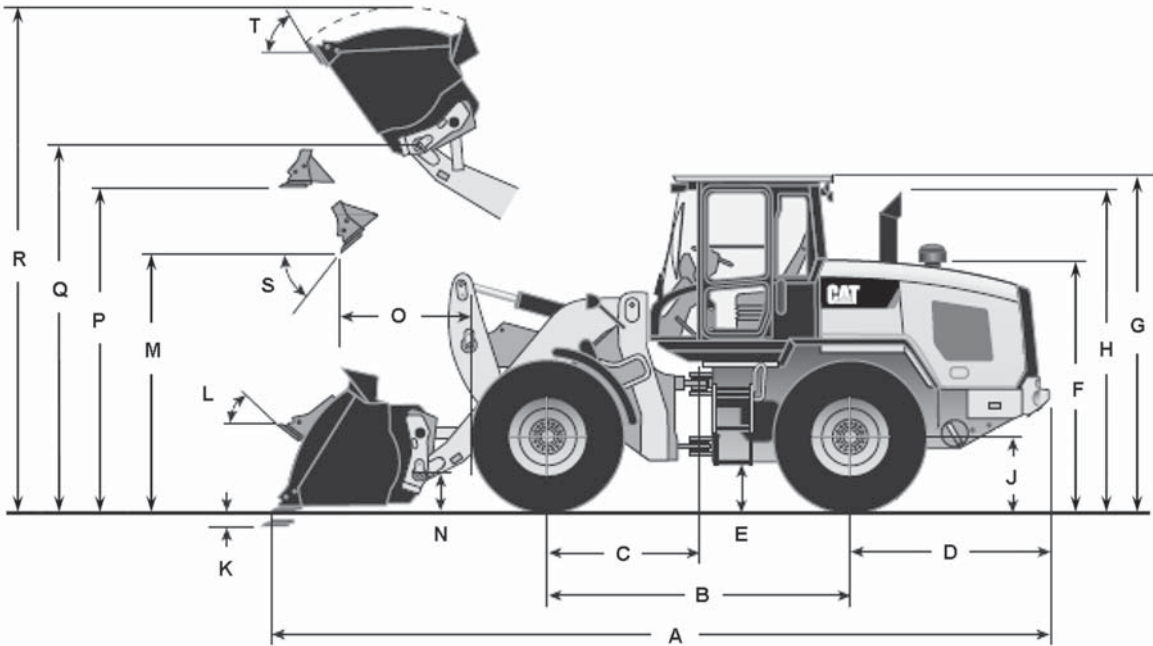

Dimensions listed are for a machine configured with Fusion general purpose bucket, bolt-on cutting edge, heavy counterweight, additional guarding, 80 kg (176 lb) operator, and Michelin 20.5 R25 (L-3) XHA2 tires.

MODEL	930M* High Lift		930M* Standard		938M* High Lift	
	Bucket	2.1 m <sup>3</sup>	2.8 yd <sup>3</sup>	2.5 m <sup>3</sup>	3.3 yd <sup>3</sup>	2.5 m <sup>3</sup>
A Maximum overall length**	8324 mm	27'4"	7656 mm	25'1"	8397 mm	27'7"
B Wheel base	3000 mm	9'10"	3050 mm	10'0"	3050 mm	10'0"
C Machine center point to front axle	1500 mm	4'11"	1525 mm	5'0"	1525 mm	5'0"
D Rear axle to counterweight	1993 mm	6'6"	1968 mm	6'5"	1968 mm	6'5"
E Ground clearance***	397 mm	1'3"	386 mm	1'3"	386 mm	1'3"
F Height to top of engine compartment	2235 mm	7'4"	2235 mm	7'4"	2235 mm	7'4"
G Height to top of ROPS***	3340 mm	10'11"	3340 mm	10'11"	3340 mm	10'11"
H Height to top of stack	3223 mm	10'7"	3223 mm	10'7"	3223 mm	10'7"
J Tire Radius (empty machine)***	685 mm	2'3"	685 mm	2'3"	685 mm	2'3"
K Maximum digging depth (bucket level)***	135 mm	5"	100 mm	4"	135 mm	5"
L Maximum rollback at carry height		50°		45°		50°
M Dump clearance at full lift and 45° discharge angle**	3421 mm	11'2"	2834 mm	9'3"	3415 mm	11'2"
N Hinge pin height at carry position	692 mm	2'3"	467 mm	1'6"	686 mm	2'3"
O Reach at full lift and 45° dump**	1385 mm	4'6"	1146 mm	3'9"	1413 mm	4'7"
P Clearance level bucket at full height***	4073 mm	13'4"	3462 mm	11'4"	4223 mm	13'10"
Q Maximum hinge pin height***	4500 mm	14'9"	3969 mm	13'0"	4550 mm	14'11"
R Maximum overall height***	5740 mm	18'9"	5273 mm	17'3"	5853 mm	19'2"
S Full dump at maximum lift		48°		49°		47°
T Maximum roll back at maximum lift		53°		54°		53°
Tires	20.5 R25 (L-3) XHA2		20.5 R25 (L-3) XHA2		20.5 R25 (L-3) XHA2	

\*Meets Tier 4 Final/Stage IV/Japan 2014 (Tier 4 Final) emission standards.

\*\*Varies with bucket.

\*\*\*Varies with tire.



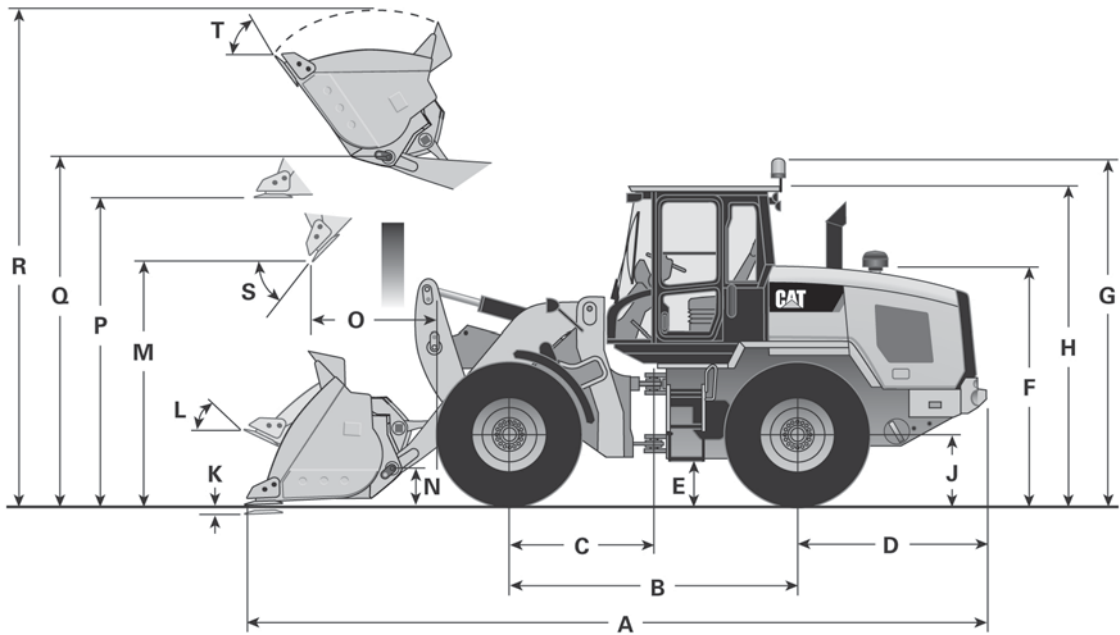

Dimensions listed are for a machine configured with general purpose pin on buckets, bolt-on cutting edges, optional counterweights, 80 kg (176 lb) operator, and Michelin 20.5 R25 (L-3) XHA2 tires.

MODEL	924K		930K		930K	
	Standard	Standard	Standard	Standard	High Lift	High Lift
Bucket	1.9 m <sup>3</sup>	2.5 yd <sup>3</sup>	2.1 m <sup>3</sup>	2.7 yd <sup>3</sup>	2.1 m <sup>3</sup>	2.7 yd <sup>3</sup>
A Maximum overall length*	7374 mm	24'2"	7488 mm	24'6"	8282 mm	27'2"
B Wheel base	3000 mm	9'10"	3000 mm	9'10"	3000 mm	9'10"
C Machine center point to front axle	1500 mm	4'11"	1500 mm	4'11"	1500 mm	4'11"
D Rear axle to counterweight	1986 mm	6'6"	1993 mm	6'6"	1993 mm	6'6"
E Ground clearance**	397 mm	1'3"	397 mm	1'3"	397 mm	1'3"
F Height to top of engine compartment	2235 mm	7'4"	2235 mm	7'4"	2235 mm	7'4"
G Height to top of ROPS**	3340 mm	10'11"	3340 mm	10'11"	3340 mm	10'11"
H Height to top of stack	3223 mm	10'7"	3223 mm	10'7"	3223 mm	10'7"
J Tire Radius (empty machine)**	685 mm	2'2"	685 mm	2'2"	685 mm	2'2"
K Maximum digging depth (bucket level)**	100 mm	3.9"	100 mm	3.9"	135 mm	5.3"
L Maximum rollback at carry height		43°		45°		51°
M Dump clearance at full lift and 45° discharge angle*	2857 mm	9'4"	2855 mm	9'4"	3448 mm	11'3"
N Hinge pin height at carry position	447 mm	1'5"	458 mm	1'6"	692 mm	2'3"
O Reach at full lift and 45° dump*	950 mm	3'1"	1033 mm	3'4"	1353 mm	4'5"
P Clearance level bucket at full height**	3526 mm	11'6"	3580 mm	11'8"	4173 mm	13'8"
Q Maximum hinge pin height**	3853 mm	12'7"	3907 mm	12'9"	4500 mm	14'9"
R Maximum overall height**	4997 mm	16'4"	5122 mm	16'9"	5715 mm	18'8"
S Full dump at maximum lift		50°		49°		48°
T Maximum roll back at maximum lift		53°		54°		53°
Tires	20.5 R25 (L-3) XHA2		20.5 R25 (L-3) XHA2		20.5 R25 (L-3) XHA2	

\*Varies with bucket.

\*\*Varies with tires.

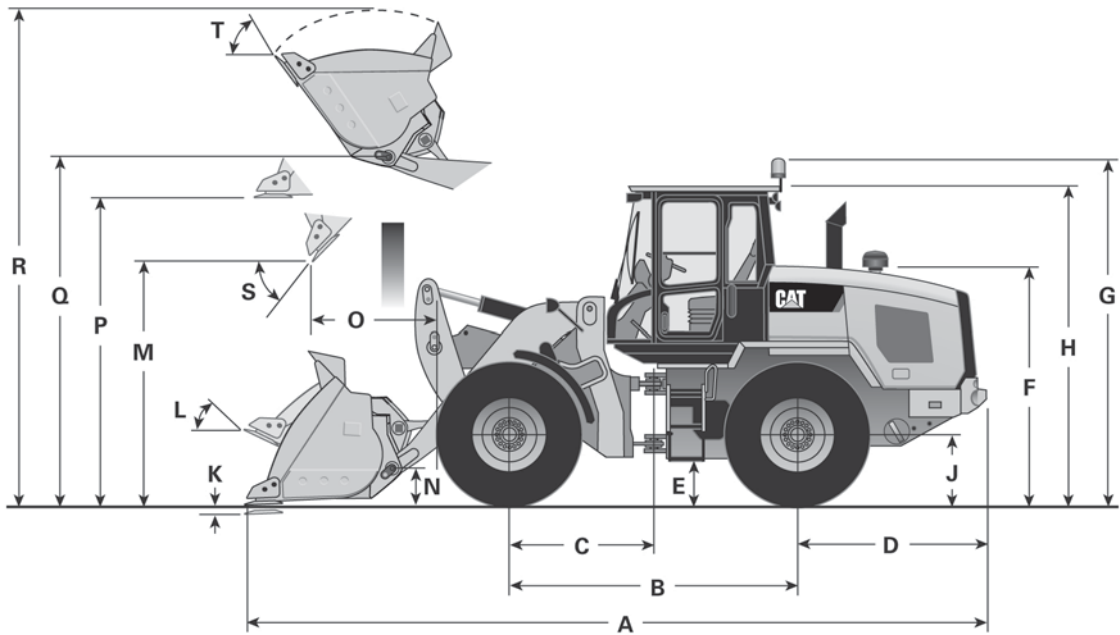

Dimensions listed are for a machine configured with general purpose pin on buckets, bolt-on cutting edges, optional counterweights, 80 kg (176 lb) operator, and Michelin 20.5 R25 (L-3) XHA2 tires.

MODEL	938K Standard		938K High Lift	
	Bucket	2.5 m <sup>3</sup>	3.3 yd <sup>3</sup>	2.5 m <sup>3</sup>
A Maximum overall length*	7604 mm	24'11"	8344 mm	27'4"
B Wheel base	3050 mm	10'0"	3050 mm	10'0"
C Machine center point to front axle	1525 mm	5'0"	1525 mm	5'0"
D Rear axle to counterweight	1968 mm	6'5"	1968 mm	6'5"
E Ground clearance**	386 mm	1'3"	386 mm	1'3"
F Height to top of engine compartment	2235 mm	7'4"	2235 mm	7'4"
G Height to top of ROPS**	3340 mm	10'11"	3340 mm	10'11"
H Height to top of stack	3223 mm	10'7"	3223 mm	10'7"
J Tire Radius (empty machine)**	685 mm	2'2"	685 mm	2'2"
K Maximum digging depth (bucket level)**	100 mm	3.9"	135 mm	5.3"
L Maximum rollback at carry height		45°		50°
M Dump clearance at full lift and 45° discharge angle*	2869 mm	9'4"	3450 mm	11'3"
N Hinge pin height at carry position	467 mm	1'6"	686 mm	2'2"
O Reach at full lift and 45° dump*	1108 mm	3'7"	1374 mm	4'6"
P Clearance level bucket at full height**	3642 mm	11'11"	4223 mm	13'10"
Q Maximum hinge pin height**	3969 mm	13'0"	4550 mm	14'11"
R Maximum overall height**	5242 mm	17'2"	5823 mm	19'1"
S Full dump at maximum lift		49°		47°
T Maximum roll back at maximum lift		54°		53°
Tires	20.5 R25 (L-3) XHA2		20.5 R25 (L-3) XHA2	

\*Varies with bucket.  
\*\*Varies with tires.

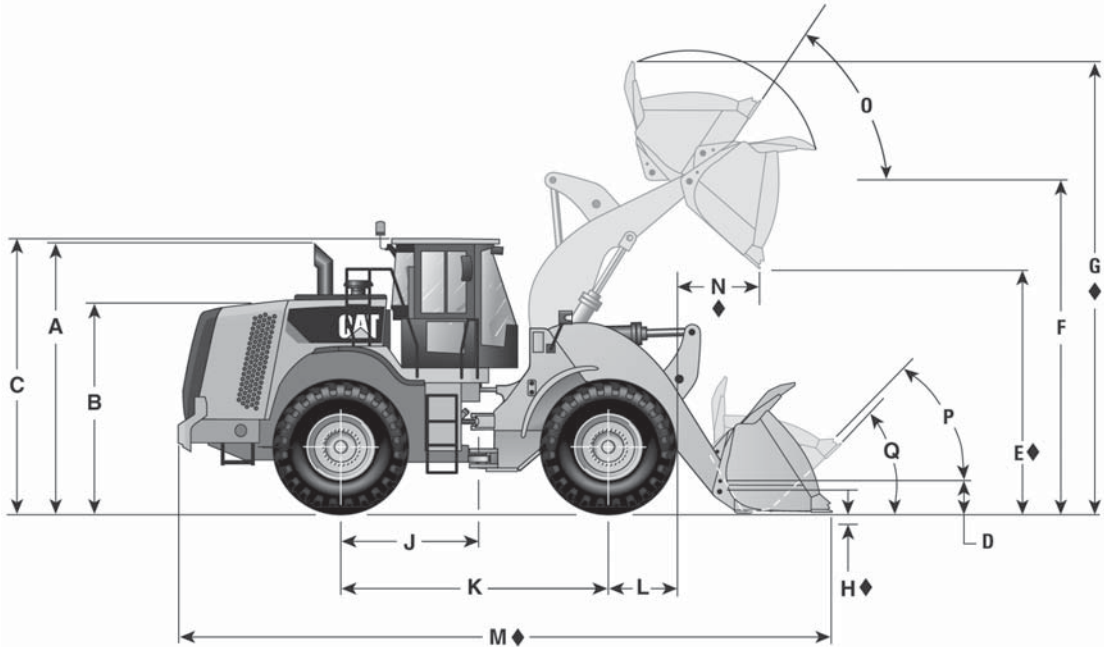

Dimensions shown represent standard machine with bucket, bolt-on cutting edge, and standard tires.

◆ Varies with Bucket Size and/or Bucket Configuration — Refer to Performance Data.

MODEL	950L General Purpose Bolt-on Edges		950M General Purpose Bolt-on Edges	
	3.1 m <sup>3</sup>	4.1 yd <sup>3</sup>	3.1 m <sup>3</sup>	4.1 yd <sup>3</sup>
A Height to top of exhaust pipe	3415 mm	11'2"	3427 mm	11'3"
B Height to top of engine compartment	2697 mm	8'10"	2697 mm	8'10"
C Height to top of ROPS	3446 mm	11'4"	3446 mm	11'4"
D Hinge pin height at carry position	663 mm	2'2"	659 mm	26"
◆ E Dump clearance at full lift and 45° discharge angle	2856 mm	9'4"	2876 mm	9'5"
F Hinge pin height at full lift	3995 mm	13'1"	4021 mm	13'2"
◆ G Maximum overall height	5325 mm	17'6"	5524 mm	18'2"
◆ H Maximum digging depth	89 mm	3.5"	90 mm	3.5"
J Machine center point to axle	1675 mm	5'6"	1675 mm	5'6"
K Wheel base	3350 mm	11'0"	3350 mm	11'0"
L Radius of tire	747 mm	2'5"	746 mm	29"
◆ M Maximum overall length	8249 mm	27'1"	8199 mm	26'11"
◆ N Reach at full lift	1319 mm	4'3"	1429 mm	4'8"
O Maximum rollback at maximum lift		60°		59°
P Maximum rollback at carry height		49°		46°
Q Maximum rollback at ground		41°		45°
Ground clearance (std. tires)	368 mm	1'2"	385 mm	1'3"
Tread width (std. tires)	2140 mm	7'0"	2140 mm	7'0"
Width over tires (std. tires)	2814 mm	9'3"	2790 mm	9'2"
Tires used for measurements	L3 Michelin XHA2		L3 Michelin XHA2	

These machines are only available in certain regions. Contact your local Cat dealer for product availability.

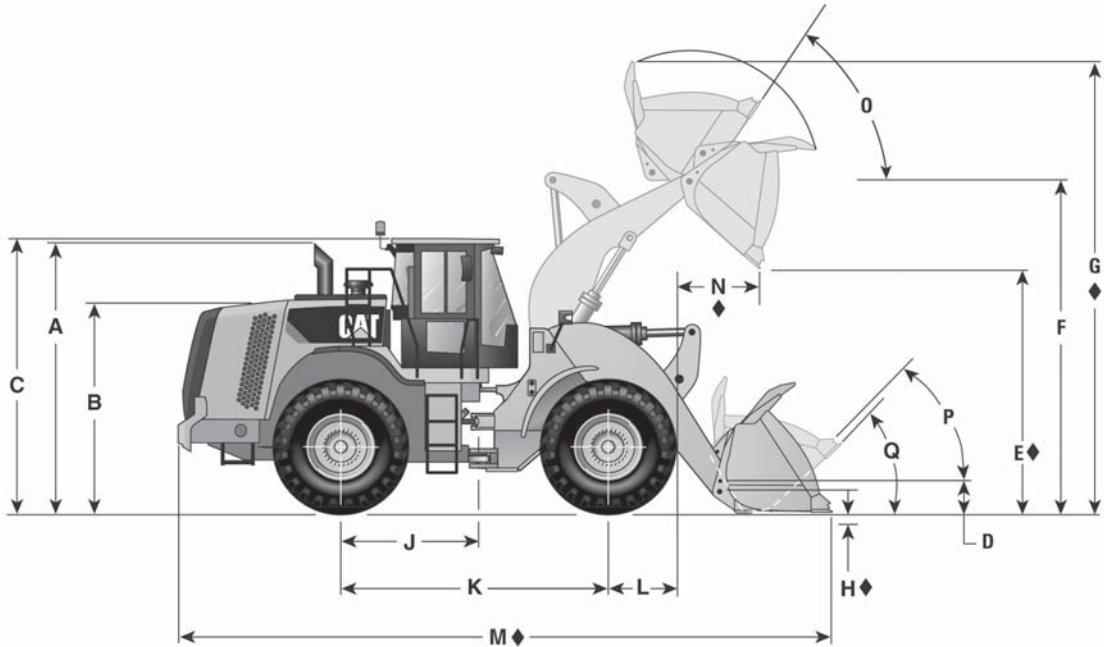

Dimensions shown represent standard machine with bucket, bolt-on cutting edge, and standard tires.

◆ Varies with Bucket Size and/or Bucket Configuration — Refer to Performance Data.

MODEL	962L General Purpose Bolt-on Edges		962M General Purpose Bolt-on Edges	
	3.3 m <sup>3</sup>	4.3 yd <sup>3</sup>	3.3 m <sup>3</sup>	4.3 yd <sup>3</sup>
A Height to top of exhaust pipe	3412 mm	11'2"	3424 mm	11'3"
B Height to top of engine compartment	2694 mm	8'10"	2694 mm	8'10"
C Height to top of ROPS	3443 mm	11'4"	3443 mm	11'4"
D Hinge pin height at carry position	642 mm	2'1"	690 mm	27"
◆ E Dump clearance at full lift and 45° discharge angle	3007 mm	9'10"	3055 mm	10'0"
F Hinge pin height at full lift	4182 mm	13'9"	4237 mm	13'10"
◆ G Maximum overall height	5690 mm	18'8"	5787 mm	19'0"
◆ H Maximum digging depth	90 mm	3.5"	88 mm	3.5"
J Machine center point to axle	1675 mm	5'6"	1675 mm	5'6"
K Wheel base	3350 mm	11'0"	3350 mm	11'0"
L Radius of tire	744 mm	2'5"	746 mm	29"
◆ M Maximum overall length	8489 mm	27'11"	8574 mm	28'2"
◆ N Reach at full lift	1299 mm	4'3"	1392 mm	4'6"
O Maximum rollback at maximum lift		60°		55°
P Maximum rollback at carry height		49°		51°
Q Maximum rollback at ground		40°		46°
Ground clearance (std. tires)	365 mm	1'2"	385 mm	1'3"
Tread width (std. tires)	2140 mm	7'0"	2140 mm	7'0"
Width over tires (std. tires)	2814 mm	9'3"	2790 mm	9'2"
Tires used for measurements	L3 Michelin XHA2		L3 Michelin XHA2	

These machines are only available in certain regions. Contact your local Cat dealer for product availability.

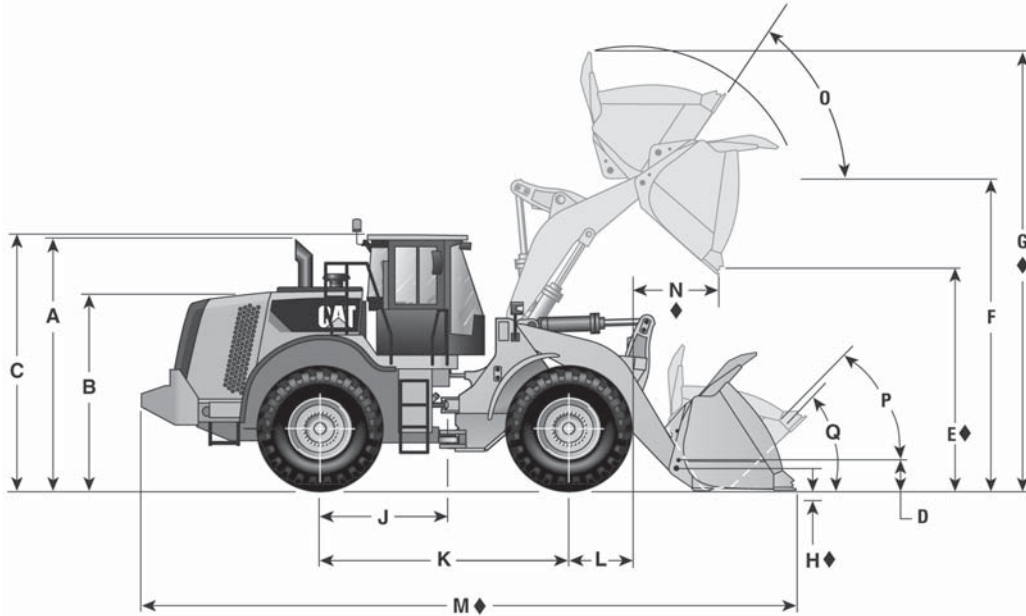

Dimensions shown represent standard machine with bucket, bolt-on cutting edge, and standard tires.

◆ Varies with Bucket Size and/or Bucket Configuration — Refer to Performance Data.

MODEL	966L/966M/966M XE General Purpose Bolt-on Edges		972L/972M/972M XE General Purpose Bolt-on Edges	
	4.2 m <sup>3</sup>	5.49 yd <sup>3</sup>	4.8 m <sup>3</sup>	6.3 yd <sup>3</sup>
A Height to top of exhaust pipe	3522 mm	11'7"	3522 mm	11'7"
B Height to top of engine compartment	2818 mm	9'3"	2818 mm	9'3"
C Height to top of ROPS	3559 mm	11'8"	3559 mm	11'8"
D Hinge pin height at carry position	630 mm	2'1"	680 mm	2'3"
◆ E Dump clearance at full lift and 45° discharge angle	2991 mm	9'9"	3154 mm	10'4"
F Hinge pin height at full lift	4235 mm	13'11"	4458 mm	14'8"
◆ G Maximum overall height	5902 mm	19'5"	6031 mm	19'10"
◆ H Maximum digging depth	124 mm	5"	103 mm	4"
J Machine center point to axle	1775 mm	5'10"	1775 mm	5'10"
K Wheel base	3550 mm	11'8"	3550 mm	11'8"
L Radius of tire	799 mm	2'7"	799 mm	2'7"
◆ M Maximum overall length	8750 mm	28'9"	9315 mm	30'7"
◆ N Reach at full lift	1353 mm	4'5"	1357 mm	4'5"
O Maximum rollback at maximum lift		62°		56°
P Maximum rollback at carry height		50°		50°
Q Maximum rollback at ground		42°		41°
Ground clearance (std. tires)	476 mm	1'7"	476 mm	1'7"
Tread width (std. tires)	2230 mm	7'4"	2230 mm	7'4"
Width over tires (std. tires)	2991 mm	9'10"	2991 mm	9'10"
Tires used for measurements	L3 Michelin XHA2		L3 Michelin XHA3	

These machines are only available in certain regions. Contact your local Cat dealer for product availability.

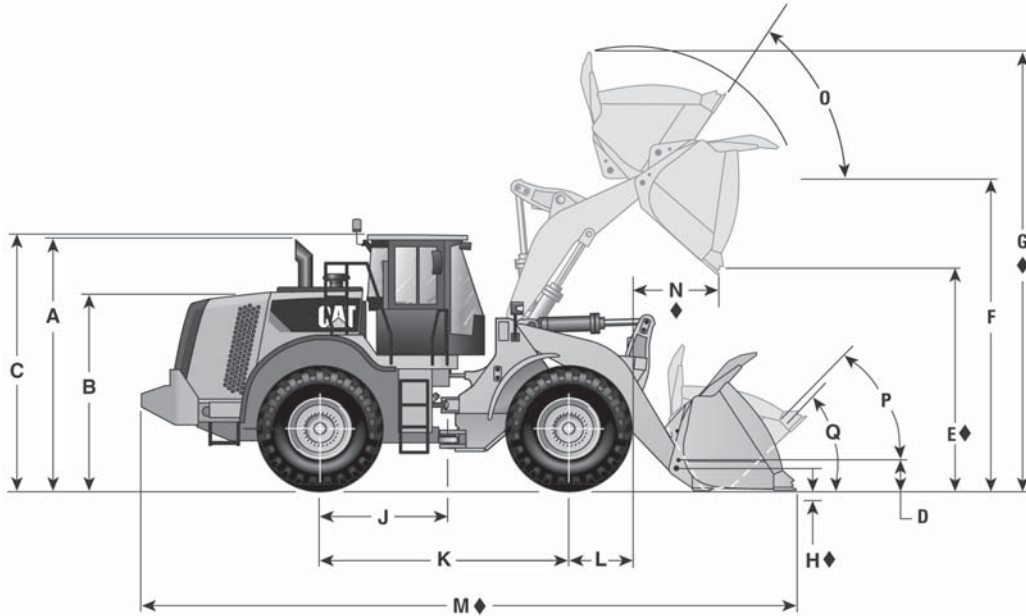

Dimensions shown represent standard machine with bucket, bolt-on cutting edge, and standard tires.

◆ Varies with Bucket Size and/or Bucket Configuration — Refer to Performance Data.

MODEL	980L/980M General Purpose Bolt-on Edges		982M General Purpose Bolt-on Edges	
	5.4 m <sup>3</sup>	7.1 yd <sup>3</sup>	6.1 m <sup>3</sup>	8.0 yd <sup>3</sup>
A Height to top of exhaust pipe	3746 mm	12'4"	3719 mm	12'3"
B Height to top of engine compartment	3110 mm	10'3"	3083 mm	10'2"
C Height to top of ROPS	3813 mm	12'7"	3786 mm	12'6"
D Hinge pin height at carry position	621 mm	2'1"	790 mm	2'8"
◆ E Dump clearance at full lift and 45° discharge angle	3273 mm	10'9"	3365 mm	11'1"
F Hinge pin height at full lift	4539 mm	14'11"	4743 mm	15'7"
◆ G Maximum overall height	6421 mm	21'1"	6592 mm	21'8"
◆ H Maximum digging depth	103 mm	5"	116 mm	5"
J Machine center point to axle	1900 mm	6'3"	1900 mm	6'3"
K Wheel base	3800 mm	12'6"	3800 mm	12'6"
L Radius of tire	885 mm	2'11"	857 mm	2'10"
◆ M Maximum overall length	9493 mm	31'2"	10 177 mm	33'5"
◆ N Reach at full lift	1481 mm	4'11"	1569 mm	5'2"
O Maximum rollback at maximum lift		61°		57°
P Maximum rollback at carry height		48°		48°
Q Maximum rollback at ground		40°		42°
Ground clearance (std. tires)	453 mm	1'6"	426 mm	1'5"
Tread width (std. tires)	2440 mm	8'0"	2540 mm	8'4"
Width over tires (std. tires)	3265 mm	10'9"	3452 mm	11'4"
Tires used for measurements	L4 Michelin XLDD1		L4 Bridgestone VLTS	

These machines are only available in certain regions. Contact your local Cat dealer for product availability.

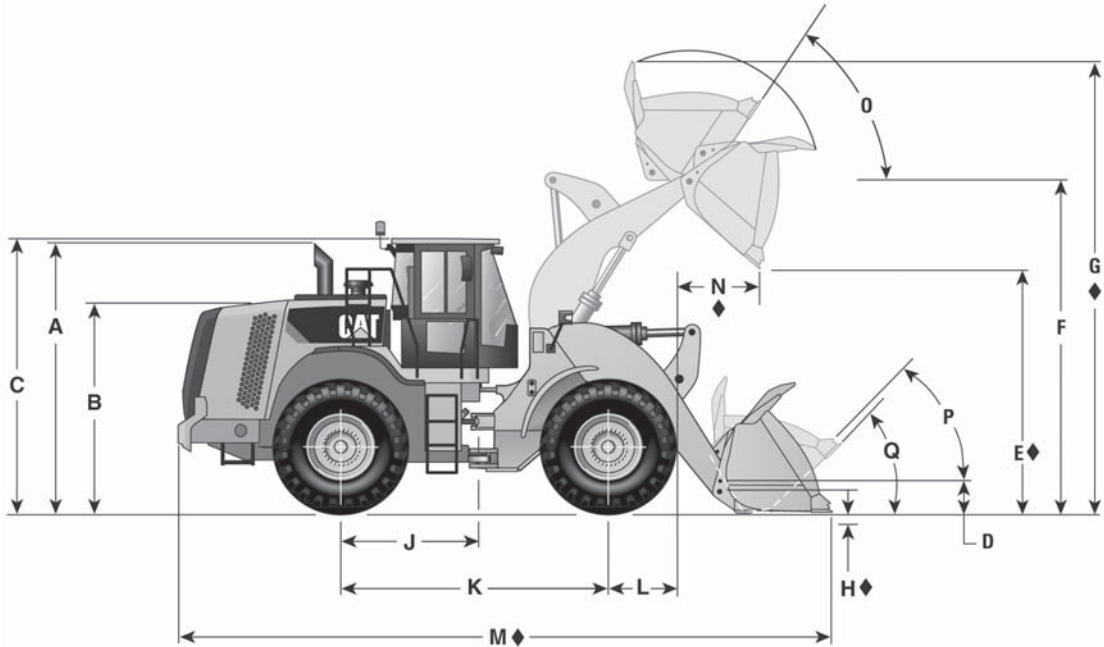

Dimensions shown represent standard machine with bucket, bolt-on cutting edge, and standard tires.

◆ Varies with Bucket Size and/or Bucket Configuration — Refer to Performance Data.

MODEL	950K General Purpose Bolt-on Edges		962K General Purpose Bolt-on Edges	
	3.1 m <sup>3</sup>	4 yd <sup>3</sup>	3.3 m <sup>3</sup>	4.3 yd <sup>3</sup>
A Height to top of exhaust pipe	3099 mm	10'2"	3099 mm	10'2"
B Height to top of engine compartment	2415 mm	7'11"	2415 mm	7'11"
C Height to top of ROPS	3356 mm	11'0"	3356 mm	11'0"
D Hinge pin height at carry position	659 mm	26"	677 mm	27"
◆ E Dump clearance at full lift and 45° discharge angle	2876 mm	9'5"	3054 mm	10'0"
F Hinge pin height at full lift	4021 mm	13'2"	4237 mm	13'10"
◆ G Maximum overall height	5525 mm	18'2"	5788 mm	19'0"
◆ H Maximum digging depth	90 mm	3.5"	88 mm	3.5"
J Machine center point to axle	1675 mm	5'6"	1675 mm	5'6"
K Wheel base	3350 mm	10'11"	3350 mm	10'11"
L Radius of tire	746 mm	29"	746 mm	29"
◆ M Maximum overall length	8162 mm	26'10"	8482 mm	27'10"
◆ N Reach at full lift	1429 mm	4'8"	1392 mm	4'6"
O Maximum rollback at maximum lift		59°		55°
P Maximum rollback at carry height		46°		51°
Q Maximum rollback at ground		45°		46°
Ground clearance (std. tires)	397 mm	1'3"	397 mm	1'3"
Tread width (std. tires)	2.14 m	7'0"	2.14 m	7'0"
Width over tires (std. tires)	2.78 m	9'1"	2.78 m	9'1"
Tires used for measurements	L3 Michelin XHA2		L3 Michelin XHA2	

These machines are only available in certain regions. Contact your local Cat dealer for product availability.

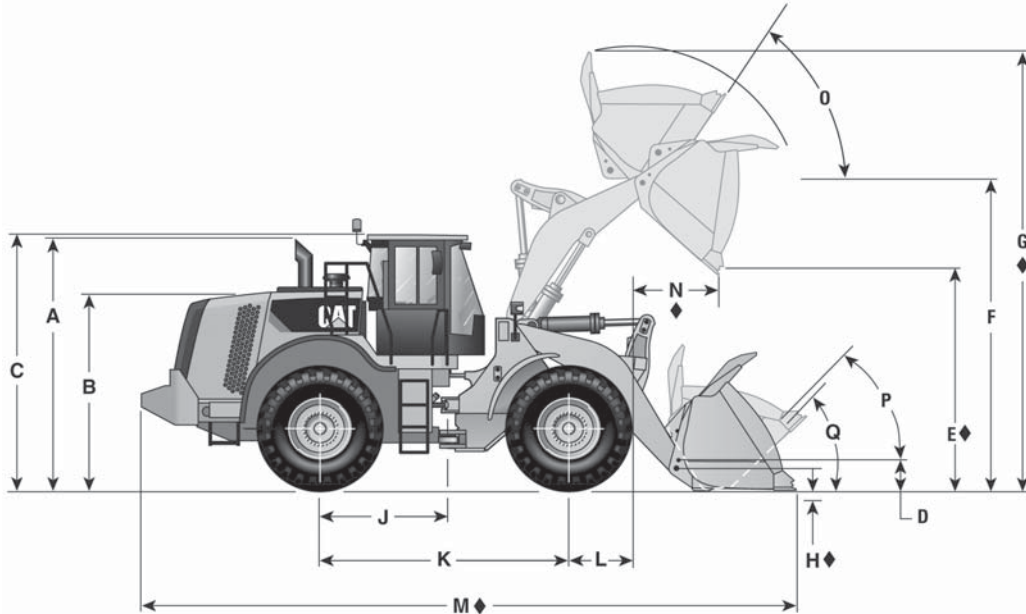

Dimensions shown represent standard machine with bucket, bolt-on cutting edge, and standard tires.

◆ Varies with Bucket Size and/or Bucket Configuration — Refer to Performance Data.

MODEL	966K General Purpose Bolt-on Edges		972K General Purpose Bolt-on Edges		980K General Purpose Bolt-on Edges	
	4.2 m <sup>3</sup>	5.49 yd <sup>3</sup>	4.8 m <sup>3</sup>	6.3 yd <sup>3</sup>	5.4 m <sup>3</sup>	7.1 yd <sup>3</sup>
A Height to top of exhaust pipe	3518 mm	11'6"	3518 mm	11'6"	3737 mm	12'4"
B Height to top of engine compartment	2828 mm	9'3"	2828 mm	9'3"	3109 mm	10'2"
C Height to top of ROPS	3547 mm	11'7"	3547 mm	11'7"	3809 mm	12'6"
D Hinge pin height at carry position	640 mm	2'1"	689 mm	2'3"	673 mm	2'0"
◆ E Dump clearance at full lift and 45° discharge angle	2991 mm	9'9"	3154 mm	10'4"	3273 mm	10'8"
F Hinge pin height at full lift	4234 mm	13'10"	4456 mm	14'7"	4539 mm	14'11"
◆ G Maximum overall height	5902 mm	19'5"	6031 mm	19'10"	6421 mm	21'1"
◆ H Maximum digging depth	124 mm	4.9"	103 mm	4"	103 mm	4"
J Machine center point to axle	2187 mm	7'2"	2473 mm	8'1"	1850 mm	6'1"
K Wheel base	3450 mm	11'3"	3450 mm	11'3"	3700 mm	12'1"
L Radius of tire	799 mm	31"	800 mm	31"	885 mm	35"
◆ M Maximum overall length	8691 mm	28'7"	9223 mm	30'4"	9509 mm	31'3"
◆ N Reach at full lift	1388 mm	4'6"	1392 mm	4'6"	1556 mm	5'1"
O Maximum rollback at maximum lift		62°		56°		61°
P Maximum rollback at carry height		50°		50°		49°
Q Maximum rollback at ground		42°		41°		41°
Ground clearance (std. tires)	475 mm	1'6"	475 mm	1'6"	460 mm	1'6"
Tread width (std. tires)	2.23 m	7'4"	2.23 m	7'4"	2.44 m	8'0"
Width over tires (std. tires)	3.00 m	9'10"	3.00 m	9'10"	3.25 m	10'8"
Tires used for measurements	L3 Michelin XHA2		L3 Michelin XHA3		L4 Michelin XLDD1	

These machines are only available in certain regions. Contact your local Cat dealer for product availability.



# Wheel Loaders Integrated Toolcarriers

# Machine Dimensions

● 950 GC, 950H, 962H

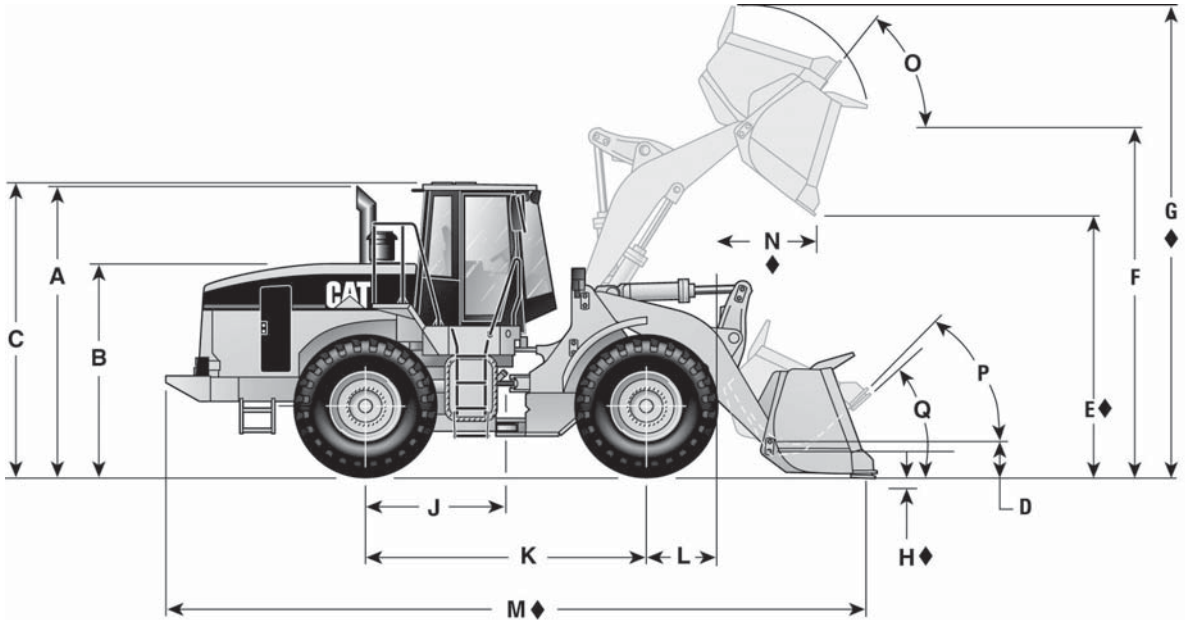

Dimensions shown represent standard machine with bucket, bolt-on cutting edge, and standard tires.

◆ Varies with Bucket Size and/or Bucket Configuration — Refer to Performance Data.

MODEL	950 GC General Purpose Bolt-on Edges		950H General Purpose Bolt-on Edges		962H General Purpose Bolt-on Edges	
	3.3 m <sup>3</sup>	4.3 yd <sup>3</sup>	3.1 m <sup>3</sup>	4 yd <sup>3</sup>	3.5 m <sup>3</sup>	4.5 yd <sup>3</sup>
A Height to top of exhaust pipe	3596 mm	11'9"	3278 mm	10'8"	3278 mm	10'8"
B Height to top of engine compartment	2568 mm	8'5"	2448 mm	8'0"	2448 mm	8'0"
C Height to top of ROPS	3458 mm	11'4"	3461 mm	11'4"	3461 mm	11'4"
D Hinge pin height at carry position	655 mm	2'1"	624 mm	2'0"	664 mm	2'2"
◆ E Dump clearance at full lift and 45° discharge angle	3012 mm	9'10"	2936 mm	9'7"	3046 mm	9'11"
F Hinge pin height at full lift	4188 mm	13'8"	3992 mm	13'1"	4182 mm	13'7"
◆ G Maximum overall height	5693 mm	18'8"	5363 mm	17'8"	5515 mm	18'2"
◆ H Maximum digging depth	86 mm	3"	89 mm	3.5"	90 mm	3.5"
J Machine center point to axle	1650 mm	5'4"	1675 mm	5'5"	1675 mm	5'5"
K Wheel base	3300 mm	10'9"	3350 mm	11'0"	3350 mm	11'0"
L Radius of tire	750 mm	2'5"	746 mm	2'5"	746 mm	2'5"
◆ M Maximum overall length	8288 mm	27'2"	7961 mm	26'2"	8291 mm	27'3"
◆ N Reach at full lift	1292 mm	4'2"	1263 mm	4'1"	1269 mm	4'1"
O Maximum rollback at maximum lift		60°		59.5°		59.5°
P Maximum rollback at carry height		45°		49.4°		48.5°
Q Maximum rollback at ground		40°		41°		40°
Ground clearance (std. tires)	460 mm	1'6"	397 mm	1'3"	397 mm	1'3"
Tread width (std. tires)	2150 mm	7'0"	2140 mm	7'0"	2140 mm	7'0"
Width over tires (std. tires)	2751 mm	9'0"	2784 mm	11'0"	2784 mm	11'0"
Tires used for measurements	L3 Triangle TB516		23.5R25 L3 Michelin XHA2		23.5R25 L3 Michelin XHA2	

These machines are only available in certain regions. Contact your local Cat dealer for product availability.

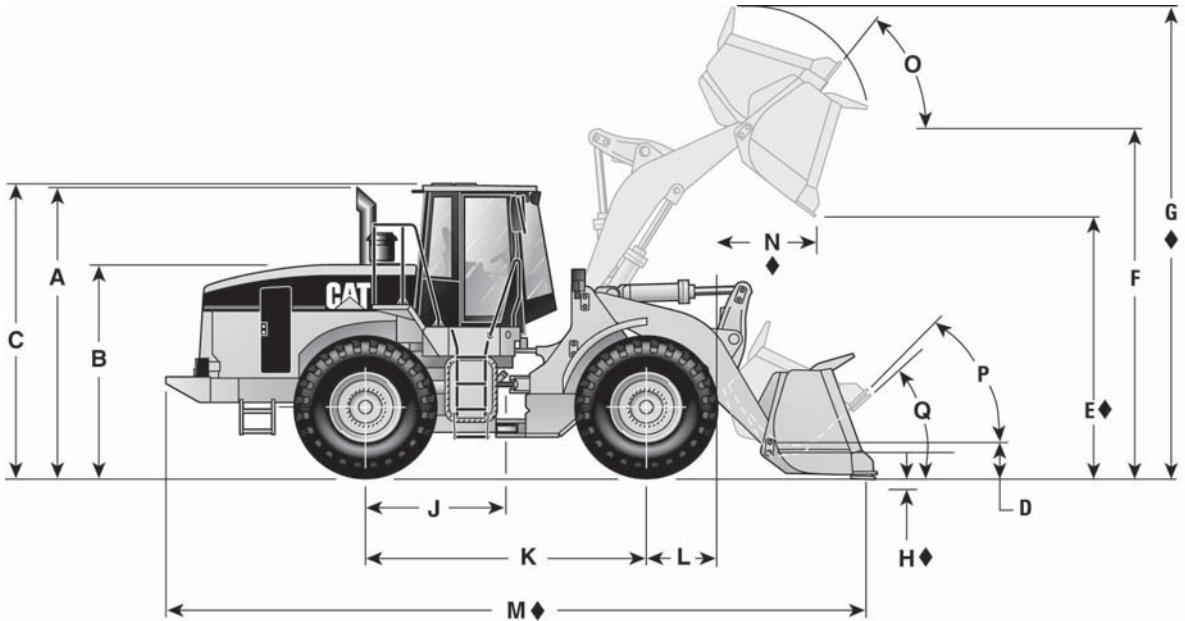

Dimensions shown represent standard machine with general purpose bucket and standard tires.

◆ Varies with Bucket Size and/or Bucket Configuration — Refer to Performance Data.

MODEL	966H General Purpose Bolt-on Edges		972H General Purpose Bolt-on Edges		980H General Purpose Bolt-on Edges	
	4.0 m <sup>3</sup>	5.2 yd <sup>3</sup>	4.6 m <sup>3</sup>	6.0 yd <sup>3</sup>	5.4 m <sup>3</sup>	7.1 yd <sup>3</sup>
A Height to top of stack	3524 mm	11'6"	3524 mm	11'6"	3714 mm	12'2"
B Height to top of engine compartment	2655 mm	8'8"	2655 mm	8'8"	2721 mm	8'11"
C Height to top of ROPS	3575 mm	11'8"	3575 mm	11'8"	3776 mm	12'4"
D Hinge pin height at carry position	641 mm	25"	691 mm	27"	644 mm	25"
◆ E Dump clearance at full lift and 45° discharge angle	3058 mm	10'0"	3187 mm	10'5"	3242 mm	10'7"
F Hinge pin height at full lift	4235 mm	13'10"	4458 mm	14'7"	4509 mm	14'9"
◆ G Maximum overall height	5902 mm	19'5"	6195 mm	20'4"	6391 mm	21'0"
◆ H Maximum digging depth	124 mm	5"	103 mm	4"	133 mm	5"
J Machine center point to axle	1725 mm	5'7"	1725 mm	5'7"	1850 mm	6'1"
K Wheel base	3450 mm	11'3"	3450 mm	11'3"	3700 mm	12'2"
L Radius of tire	799 mm	2'8"	799 mm	2'8"	855 mm	2'9"
◆ M Maximum overall length	8693 mm	28'7"	9177 mm	30'2"	9637 mm	31'8"
◆ N Reach at full lift	1334 mm	4'4"	1363 mm	4'5"	1580 mm	5'2"
O Maximum rollback at maximum lift		61°		55°		61°
P Maximum rollback at carry height		50°		50°		49°
Q Maximum rollback at ground		42°		41°		41°
Ground clearance (std. tires)	434 mm	1'5"	434 mm	1'5"	430 mm	1'4"
Tread width (std. tires)	2233 mm	7'3"	2233 mm	7'3"	2428 mm	8'0"
Width over tires (std. tires)	2914 mm	9'6"	2914 mm	9'6"	3175 mm	10'5"
Tires used for measurements	26.5R25 L3 Michelin XHA2		26.5R25 L3 Michelin XHA2		29.5R25 L3 Michelin XHA2	

These machines are only available in certain regions. Contact your local Cat dealer for product availability.

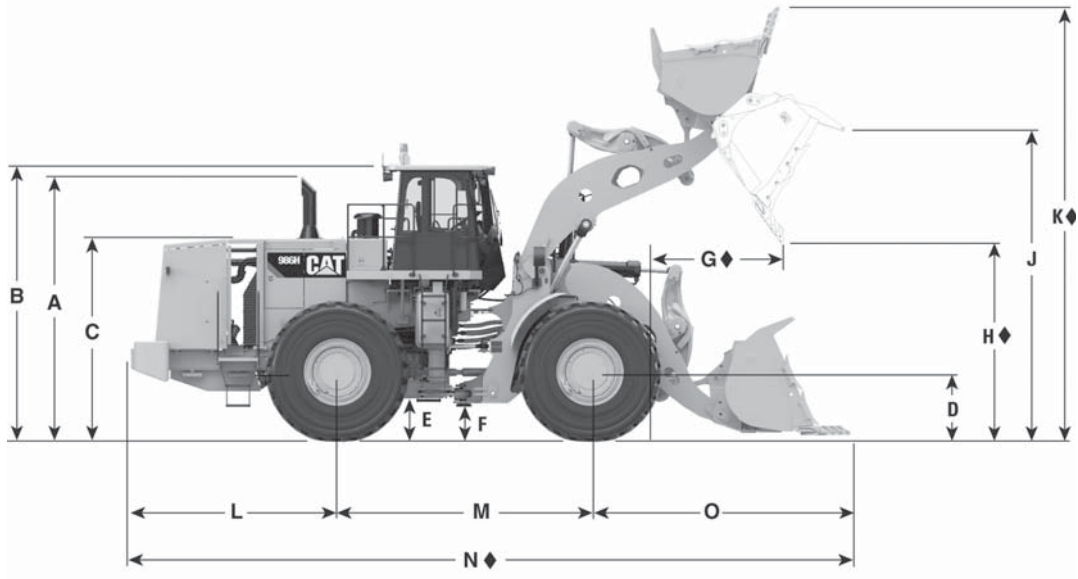

◆ Varies with Bucket Size and/or Bucket Configuration — Refer to Performance Data.

MODEL	986H Standard Lift		986H High Lift		
	A	Ground to top of exhaust stacks	3940 mm	12.9'	3940 mm
B	Ground to top of ROPS	4110 mm	13.5'	4110 mm	13.5'
C	Ground to top of hood	2991 mm	9.8'	2991 mm	9.8'
D	Ground to center of front axle	978 mm	3.2'	978 mm	3.2'
E	Ground to fuel tank clearance	691 mm	2.3'	691 mm	2.3'
F	Ground to lower hitch clearance	459 mm	1.5'	459 mm	1.5'
◆ G	Reach at maximum lift	2022 mm	6.6'	1904 mm	6.2'
◆ H	Clearance at maximum lift	3234 mm	10.6'	3738 mm	12.3'
J	B-pin height at maximum lift	4912 mm	16.1'	5371 mm	17.6'
◆ K	Maximum overall height, bucket raised	6671 mm	21.9'	7067 mm	23.2'
L	Rear axle center line to bumper	3132 mm	10.3'	3132 mm	10.3'
M	Wheel base	3810 mm	12.5'	3810 mm	12.5'
◆ N	Maximum overall length	10 907 mm	35.8'	11 290 mm	37.0'
O	Front axle center line to bucket tip	3987 mm	13.1'	4370 mm	14.3'

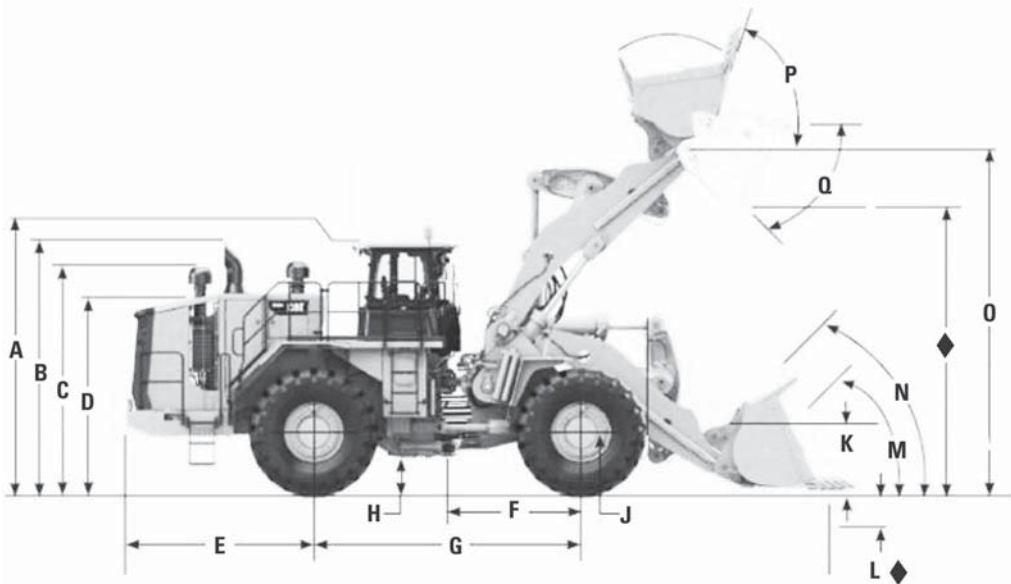

◆ Dimensions vary with bucket. Refer to Operation/Bucket Specifications.

MODEL	988K High Lift	
A Height to top of cab	4221 mm	13.8'
B Height to top of exhaust stack	4214 mm	13.8'
C Height to top of air cleaner	3881 mm	12.7'
D Height to top of hood	3329 mm	10.9'
E Center line of rear axle to edge of rear bumper	3187 mm	10.5'
F Center line of front axle to hitch	2275 mm	7.46'
G Wheel base length	4550 mm	14.93'
H Ground clearance	568 mm	1.9'
J Height to center of wheel	973 mm	3.2'
K C-pin height**	944 mm	3.1'
L Dig depth	220 mm	9"
	204 mm*	8"
M Rack back angle at ground	44.7°	
	43.6°*	
N Rack back angle at carry	52.9°	
	51°*	
O B-pin height	5881 mm	19.3'
	5479 mm*	18.0'
P Rack back angle at maximum lift	64.3°	
Q Dump angle at maximum lift	-50.1°	

\*Standard Lift.

**Wheel Loaders  
Integrated Toolcarriers**

**Machine Dimensions**

- 988K
- Tire Dimensions/Specifications

<b>Tire Dimensions/Specifications</b>	<b>Width over Tires</b>		<b>Ground Clearance</b>		<b>Change in Vertical Dimensions</b>		<b>Change in Full Turn Static Tipping Load</b>	
	<b>mm</b>	<b>in</b>	<b>mm</b>	<b>in</b>	<b>mm</b>	<b>in</b>	<b>kg</b>	<b>lb</b>
35/65R33 (L-4) Michelin XLDD1	3598	<b>140.1</b>	526	<b>20.7</b>	0	<b>0</b>	0	<b>0</b>
35/65-33 42 PR (L-5) Bridgestone D-Lug	3541	<b>139.4</b>	565	<b>22.2</b>	39	<b>1.5</b>	1855	<b>4090</b>
35/65R33 (L-4) Bridgestone V-Steel N Traction VSNT	3569	<b>140.5</b>	541	<b>21.3</b>	15	<b>0.6</b>	287	<b>633</b>
35/65R33 (L-5) Bridgestone V-Steel D-Lug VSDL	3540	<b>139.4</b>	541	<b>21.3</b>	15	<b>0.6</b>	911	<b>2008</b>
35/65-33 42PR (L-5) Goodyear NRL D/L 5A	3487	<b>137.3</b>	553	<b>21.8</b>	27	<b>1.1</b>	2144	<b>4727</b>
875/65R33 (L-5) RL-5K	3536	<b>139.2</b>	543	<b>21.4</b>	17	<b>0.7</b>	1036	<b>2284</b>
35/65R33 (L-5) Michelin XLDD2	3549	<b>139.7</b>	536	<b>21.1</b>	10	<b>0.4</b>	242	<b>534</b>

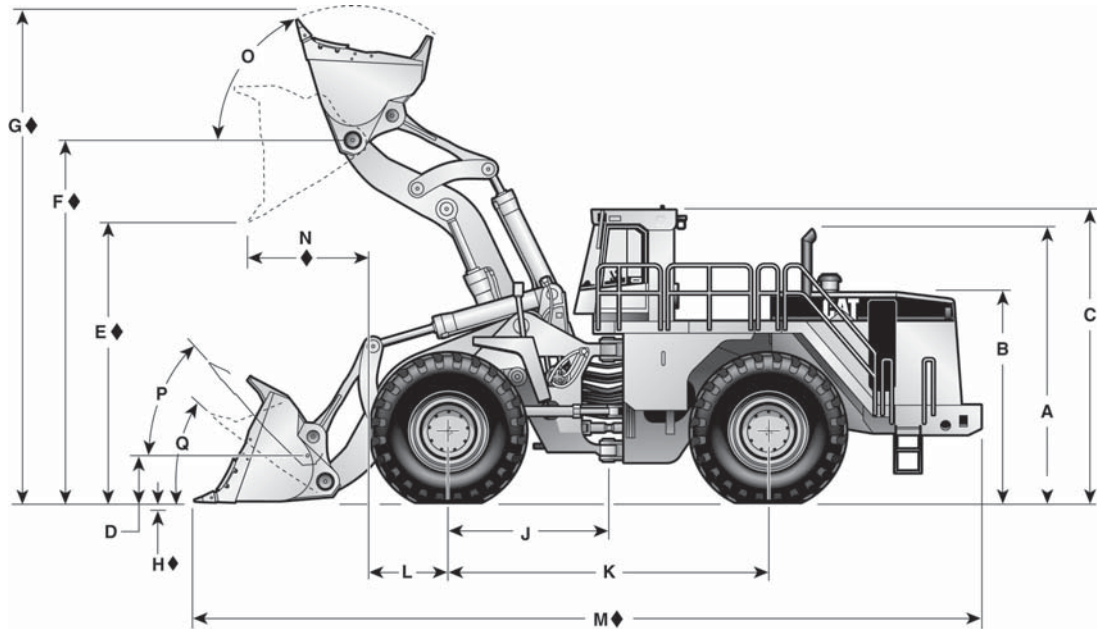

Dimensions shown represent standard machine with spade edge rock bucket and standard tires.

◆ Varies with Bucket Size and/or Bucket Configuration – Refer to Performance Data

MODEL	990K Spade Edge Rock with Teeth		990K High Lift Spade Edge Rock with Teeth		992K Spade Edge Rock with Teeth		992K High Lift Spade Edge Rock with Teeth	
	8.5 m <sup>3</sup>	11.1 yd <sup>3</sup>	8.5 m <sup>3</sup>	11.1 yd <sup>3</sup>	12.3 m <sup>3</sup>	16.0 yd <sup>3</sup>	10.7 m <sup>3</sup>	14 yd <sup>3</sup>
A Height to top of stack	5.05 m	16.6'	5.05 m	16.6'	5.24 m	17'2"	5.24 m	17'2"
B Height to top of engine compartment	3.86 m	12.7'	3.86 m	12.7'	4.0 m	13'1"	4.0 m	13'1"
C Height to top of ROPS	5.24 m	17.2'	5.24 m	17.2'	5.67 m	18'7"	5.67 m	18'7"
D Hinge pin height at carry position	853 mm	2.8'	1060 mm	3.5'	1209 mm	4'0"	1339 mm	4'5"
◆ E Dump clearance at full lift and 45° discharge angle	4.06 m	13.3'	4.52 m	14.8'	4.49 m	14'9"	5.22 m	17'2"
◆ F Hinge pin height at full lift	6.01 m	19.7'	6.47 m	21.2'	6.92 m	22'8"	7.54 m	24'9"
◆ G Maximum overall height	8.29 m	27.2'	8.75 m	28.7'	9.49 m	31'2"	9.93 m	32'7"
◆ H Maximum digging depth	130 mm	5"	172 mm	7"	201 mm	8"	176 mm	7"
K Machine center point to axle	2.3 m	7.5'	2.3 m	7.5'	2.94 m	9'8"	2.94 m	9'8"
J Wheel base	4.6 m	15.1'	4.6 m	15.1'	5.89 m	19'4"	5.89 m	19'4"
L Radius of tire	1.29 m	4.2'	1.29 m	4.2'	1.37 m	4'6"	1.37 m	4'6"
◆ M Maximum overall length	13.07 m	42.9'	13.81 m	45.3'	15.9 m	52'2"	16.2 m	53'2"
◆ N Reach at full lift	2.19 m	7.2'	2.59 m	8.5'	2.43 m	8'0"	2.19 m	7'2"
O Maximum rollback at maximum lift	63.7°		60.6°		65°		65°	
P Maximum rollback at carry height	48.8°		49.3°		52.7°		52.5°	
Q Maximum rollback at ground	40.4°		39.9°		43.4°		42.8°	
Ground clearance (std. tires)	596 mm	2.0'	596 mm	2.0'	682 mm	26.8"	682 mm	26.8"
Tread width (std. tires)	3.05 m	10'	3.05 m	10'	3.30 m	10'10"	3.30 m	10'10"
Width over tires (std. tires)	4.24 m	13.9'	4.24 m	13.9'	4.50 m	14'9"	4.50 m	14'9"
Tires used for measurements	45/65R39 VSDL SLR: 1203 mm		45/65R39 VSDL SLR: 1203 mm		—		—	

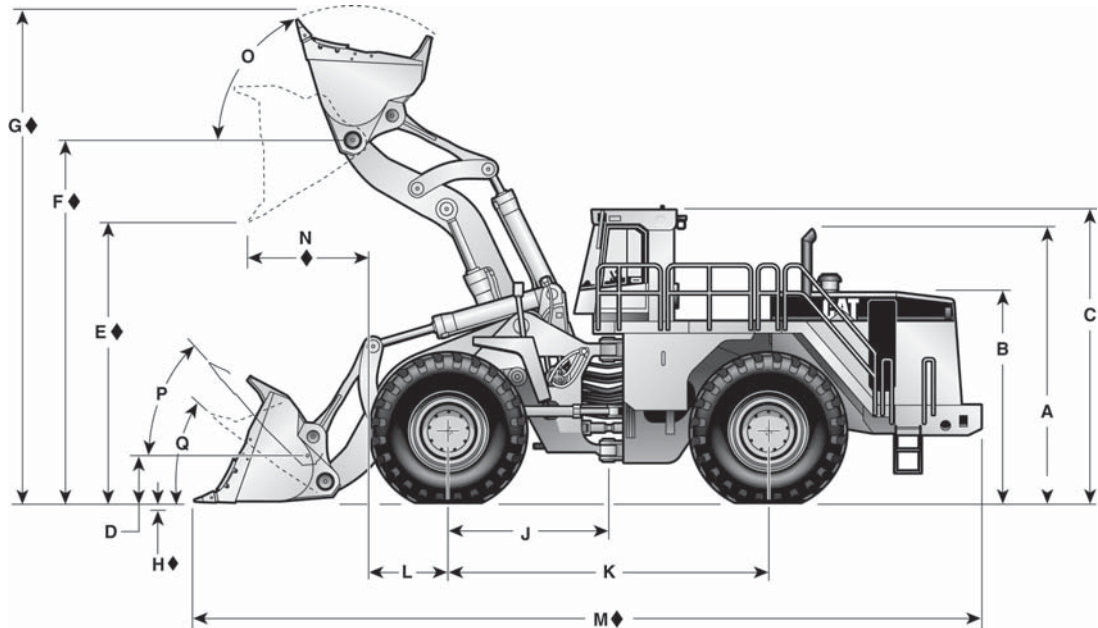

Dimensions shown represent standard machine with spade edge rock bucket and standard tires.

◆ Varies with Bucket Size and/or Bucket Configuration — Refer to Performance Data

MODEL	993K Standard Lift Spade Edge Rock with Teeth & Segments		993K High Lift Spade Edge Rock with Teeth & Segments	
	13 m <sup>3</sup>	17 yd <sup>3</sup>	13 m <sup>3</sup>	17 yd <sup>3</sup>
A Height to top of stack	5.45 m	17'9"	5.45 m	17'9"
B Height to top of engine compartment	4.25 m	14'0"	4.25 m	14'0"
C Height to top of ROPS	6.00 m	19'7"	6.00 m	19'7"
D Hinge pin height at carry position	1009 mm	39.7"	1185 mm	46.7"
◆ E Dump clearance at full lift and 45° discharge angle	4.65 m	15'3"	5.29 m	17'4"
F Hinge pin height at full lift	7.00 m	23'0"	7.64 m	25'1"
◆ G Maximum overall height	9.79 m	32'1"	10.43 m	34'0"
◆ H Maximum digging depth	181 mm	7"	246 mm	10"
J Machine center point to axle	2.94 m	9'8"	2.94 m	9'8"
K Wheel base	5.89 m	19'4"	5.89 m	19'4"
L Radius of tire	1.34 m	4'4"	1.34 m	4'4"
◆ M Maximum overall length	15.21 m	50'0"	15.84 m	52'0"
◆ N Reach at full lift	2.50 m	8'2"	2.61 m	8'6"
O Maximum rollback at maximum lift		63.9°		65.7°
P Maximum rollback at carry height		52.5°		53.5°
Q Maximum rollback at ground		46.3°		46.1°
Ground clearance (std. tires)	590 mm	2'0"	590 mm	2'0"
Tread width (std. tires)	3.54 m	11'6"	3.54 m	11'6"
Width over tires (std. tires)	4.93 m	16'2"	4.93 m	16'2"
Tires used for measurements	50/65-51 (L-5)		50/65-51 (L-5)	

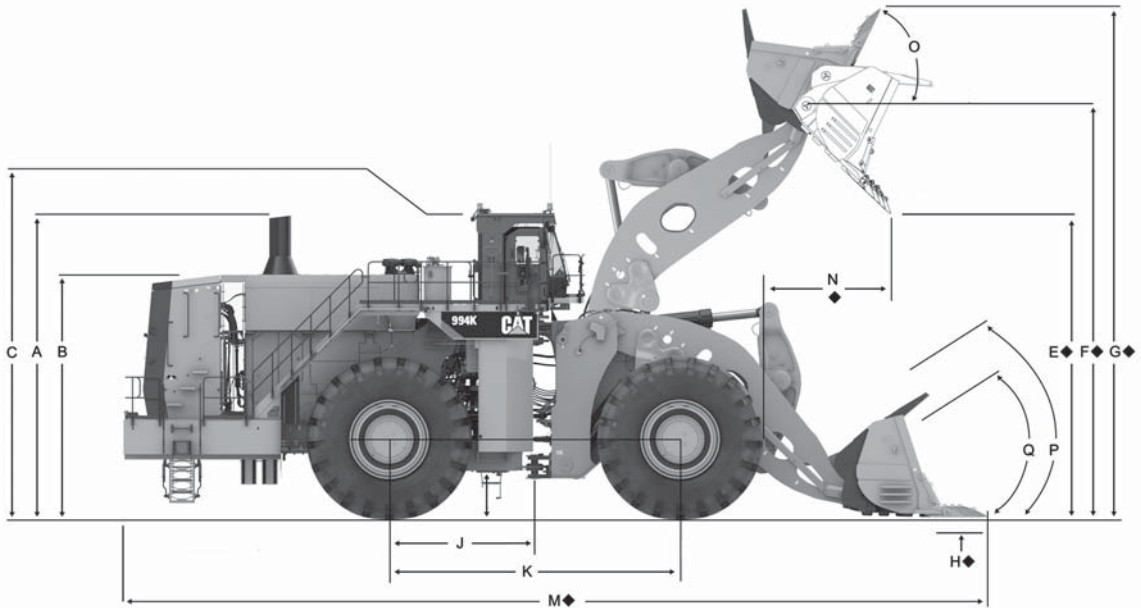

Dimensions shown represent standard machine with spade edge rock bucket and standard tires.

◆ Varies with Bucket Size and/or Bucket Configuration — Refer to Performance Data

MODEL	994K Standard Lift 6420 mm (21.1') Spade Edge Bucket with Teeth & Segments		994K Standard Lift 6420 mm (21.1') Spade Edge Bucket with Teeth & Segments		994K Standard Lift 6420 mm (21.1') Spade Edge Bucket with Teeth & Segments	
	21.4 m <sup>3</sup>	28 yd <sup>3</sup>	22.9 m <sup>3</sup>	30 yd <sup>3</sup>	24.5 m <sup>3</sup>	32 yd <sup>3</sup>
A Height to top of stack	7.1 m	23.2'	7.1 m	23.2'	7.1 m	23.2'
B Height to top of engine compartment	5.7 m	18.6'	5.7 m	18.6'	5.7 m	18.6'
C Height to top of ROPS	7.1 m	23.4'	7.1 m	23.4'	7.1 m	23.4'
D Hinge pin height at carry position	1262 mm	49.7"	1262 mm	49.7"	1262 mm	49.7"
◆ E Dump clearance at full lift and 45° discharge angle	6.24 m	20.5'	6.17 m	20.2'	6.10 m	20.0'
◆ F Hinge pin height at full lift	8.8 m	28.8'	8.8 m	28.8'	8.8 m	28.8'
◆ G Maximum overall height	11.69 m	38.3'	11.77 m	38.6'	11.87 m	39.0'
◆ H Maximum digging depth	232 mm	9.1"	232 mm	9.1"	232 mm	9.1"
J Machine center point to axle	3.4 m	11.2'	3.4 m	11.2'	3.4 m	11.2'
K Wheel base	6.8 m	22.3'	6.8 m	22.3'	6.8 m	22.3'
L Radius of tire	2.0 m	6.5'	2.0 m	6.5'	2.0 m	6.5'
◆ M Maximum overall length	17.76 m	58.3'	17.86 m	58.6'	17.96 m	58.9'
◆ N Reach at full lift	2.75 m	9.0'	2.82 m	9.3'	2.89 m	9.5'
O Maximum rollback at maximum lift	60°		60°		60°	
P Maximum rollback at carry height	48°		48°		48°	
Q Maximum rollback at ground	40°		40°		40°	
Ground clearance (std. tires)	898 mm	35.3"	898 mm	35.3"	898 mm	35.3"
Tread width (std. tires)	4.3 m	14.1'	4.3 m	14.1'	4.3 m	14.1'
Width over tires (std. tires)	5.8 m	18.0'	5.8 m	18.0'	5.8 m	18.0'
Tires used for measurements	BS 58/85-57 L-4		BS 58/85-57 L-4		BS 58/85-57 L-4	



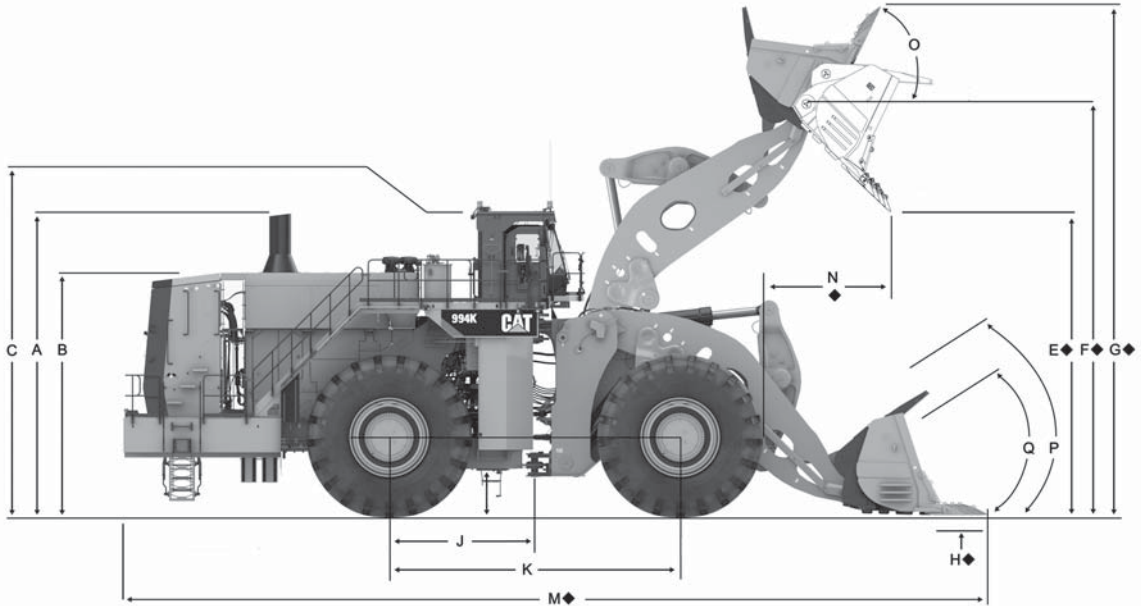

Dimensions shown represent standard machine with spade edge rock bucket and standard tires.

◆ Varies with Bucket Size and/or Bucket Configuration — Refer to Performance Data

	<b>994K High Lift 6420 mm (21.1') Spade Edge Bucket with Teeth &amp; Segments</b>		<b>994K High Lift 6420 mm (21.1') Spade Edge Bucket with Teeth &amp; Segments</b>		<b>994K High Lift 6420 mm (21.1') Spade Edge Bucket with Teeth &amp; Segments</b>	
<b>MODEL</b>	<b>19.1 m<sup>3</sup></b>	<b>25 yd<sup>3</sup></b>	<b>21.4 m<sup>3</sup></b>	<b>28 yd<sup>3</sup></b>	<b>22.9 m<sup>3</sup></b>	<b>30 yd<sup>3</sup></b>
A Height to top of stack	7.1 m	23.2'	7.1 m	23.2'	7.1 m	23.2'
B Height to top of engine compartment	5.7 m	18.6'	5.7 m	18.6'	5.7 m	18.6'
C Height to top of ROPS	7.1 m	23.4'	7.1 m	23.4'	7.1 m	23.4'
D Hinge pin height at carry position	1424 mm	56.1"	1424 mm	56.1"	1424 mm	56.1"
◆ E Dump clearance at full lift and 45° discharge angle	7.20 m	23.6'	7.10 m	23.3'	7.02 m	23.0'
◆ F Hinge pin height at full lift	8.8 m	28.8'	8.8 m	28.8'	8.8 m	28.8'
◆ G Maximum overall height	12.40 m	40.7'	12.55 m	41.2'	12.63 m	41.4'
◆ H Maximum digging depth	239 mm	9.4"	239 mm	9.4"	239 mm	9.4"
J Machine center point to axle	3.4 m	11.2'	3.4 m	11.2'	3.4 m	11.2'
K Wheel base	6.8 m	22.3'	6.8 m	22.3'	6.8 m	22.3'
L Radius of tire	2.0 m	6.5'	2.0 m	6.5'	2.0 m	6.5'
◆ M Maximum overall length	18.30 m	60.0'	18.45 m	60.5'	18.55 m	60.9'
◆ N Reach at full lift	2.58 m	8.5'	2.69 m	8.8'	2.76 m	9.0'
O Maximum rollback at maximum lift		60°		60°		60°
P Maximum rollback at carry height		54°		54°		54°
Q Maximum rollback at ground		45°		45°		45°
Ground clearance (std. tires)	898 mm	35.3"	898 mm	35.3"	898 mm	35.3"
Tread width (std. tires)	4.3 m	14.1'	4.3 m	14.1'	4.3 m	14.1'
Width over tires (std. tires)	5.8 m	18.0'	5.8 m	18.0'	5.8 m	18.0'
Tires used for measurements	<b>BS 58/85-57 L-4</b>		<b>BS 58/85-57 L-4</b>		<b>BS 58/85-57 L-4</b>	

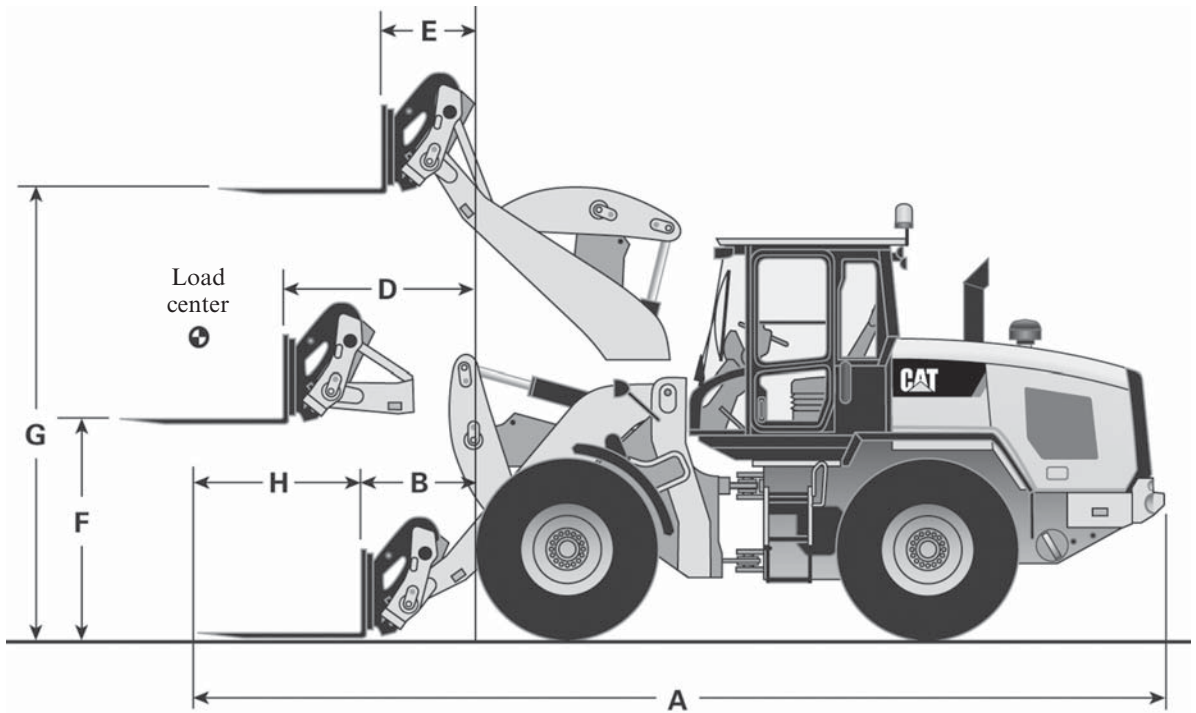

Dimensions listed are for a machine configured with Fusion coupler, standard counterweight, additional guarding, 80 kg (176 lb) operator, and Michelin 20.5 R25 (L-3) XHA2 tires.

MODEL	926M* Standard					
Rated operating load						
Per SAE J1197	2904 kg	<b>6402 lb</b>	2819 kg	<b>6214 lb</b>	2737 kg	<b>6034 lb</b>
Per CEN 474-3 rough terrain	3484 kg	<b>7680 lb</b>	3383 kg	<b>7458 lb</b>	3283 kg	<b>7239 lb</b>
Per CEN 474-3 firm level ground	4646 kg	<b>10,242 lb</b>	4510 kg	<b>9942 lb</b>	4378 kg	<b>9651 lb</b>
<b>A</b> Maximum overall length	7875 mm	<b>25'10"</b>	8025 mm	<b>26'4"</b>	8179 mm	<b>26'10"</b>
<b>B</b> Reach with forks at ground level	926 mm	<b>3'0"</b>	926 mm	<b>3'0"</b>	926 mm	<b>3'0"</b>
<b>C</b> Load center	610 mm	<b>2'0"</b>	685 mm	<b>2'3"</b>	762 mm	<b>2'6"</b>
<b>D</b> Reach with arms horizontal and forks level	1569 mm	<b>5'2"</b>	1569 mm	<b>5'2"</b>	1569 mm	<b>5'2"</b>
<b>E</b> Reach with forks at maximum height	767 mm	<b>2'6"</b>	767 mm	<b>2'6"</b>	767 mm	<b>2'6"</b>
<b>F</b> Arms horizontal and forks level	1792 mm	<b>5'11"</b>	1792 mm	<b>5'11"</b>	1792 mm	<b>5'11"</b>
<b>G</b> Ground to top of tine at maximum height	3693 mm	<b>12'1"</b>	3693 mm	<b>12'1"</b>	3693 mm	<b>12'1"</b>
<b>H</b> Fork tine length	1220 mm	<b>4'0"</b>	1370 mm	<b>4'6"</b>	1524 mm	<b>5'0"</b>
Tires	<b>20.5 R25 (L-3) XHA2</b>		<b>20.5 R25 (L-3) XHA2</b>		<b>20.5 R25 (L-3) XHA2</b>	

\*Meets Tier 4 Final/Stage IV/Japan 2014 (Tier 4 Final) emission standards.

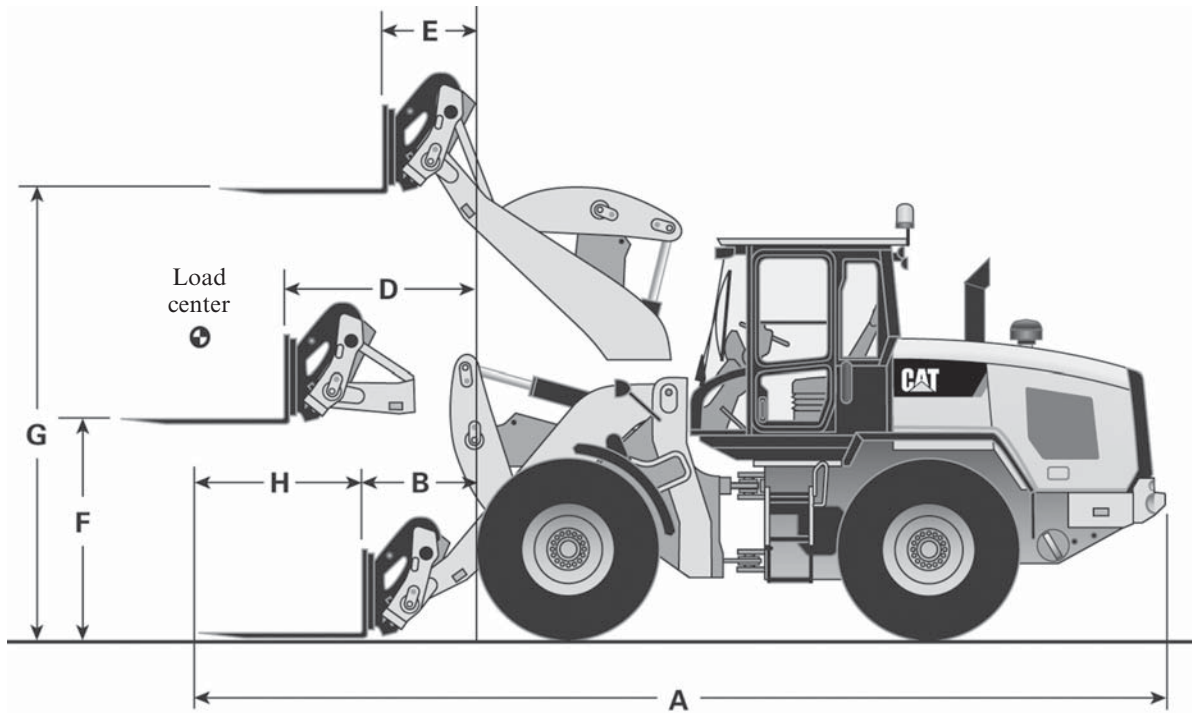

Dimensions listed are for a machine configured with Fusion coupler, standard counterweight, additional guarding, 80 kg (176 lb) operator, and Michelin 20.5 R25 (L-3) XHA2 tires.

MODEL	926M* High Lift					
Rated operating load						
Per SAE J1197	2317 kg	<b>5108 lb</b>	2256 kg	<b>4973 lb</b>	2196 kg	<b>4841 lb</b>
Per CEN 474-3 rough terrain	2780 kg	<b>6128 lb</b>	2707 kg	<b>5967 lb</b>	2635 kg	<b>5809 lb</b>
Per CEN 474-3 firm level ground	3706 kg	<b>8170 lb</b>	3610 kg	<b>7958 lb</b>	3514 kg	<b>7747 lb</b>
<b>A</b> Maximum overall length	8528 mm	<b>28'0"</b>	8678 mm	<b>28'6"</b>	8832 mm	<b>29'0"</b>
<b>B</b> Reach with forks at ground level	1578 mm	<b>5'2"</b>	1578 mm	<b>5'2"</b>	1578 mm	<b>5'2"</b>
<b>C</b> Load center	610 mm	<b>2'0"</b>	685 mm	<b>2'3"</b>	762 mm	<b>2'6"</b>
<b>D</b> Reach with arms horizontal and forks level	2092 mm	<b>6'10"</b>	2092 mm	<b>6'10"</b>	2092 mm	<b>6'10"</b>
<b>E</b> Reach with forks at maximum height	1004 mm	<b>3'4"</b>	1004 mm	<b>3'4"</b>	1004 mm	<b>3'4"</b>
<b>F</b> Arms horizontal and forks level	1792 mm	<b>5'11"</b>	1792 mm	<b>5'11"</b>	1792 mm	<b>5'11"</b>
<b>G</b> Ground to top of tine at maximum height	4186 mm	<b>13'9"</b>	4186 mm	<b>13'9"</b>	4186 mm	<b>13'9"</b>
<b>H</b> Fork tine length	1220 mm	<b>4'0"</b>	1370 mm	<b>4'6"</b>	1524 mm	<b>5'0"</b>
Tires	<b>20.5 R25 (L-3) XHA2</b>		<b>20.5 R25 (L-3) XHA2</b>		<b>20.5 R25 (L-3) XHA2</b>	

\*Meets Tier 4 Final/Stage IV/Japan 2014 (Tier 4 Final) emission standards.

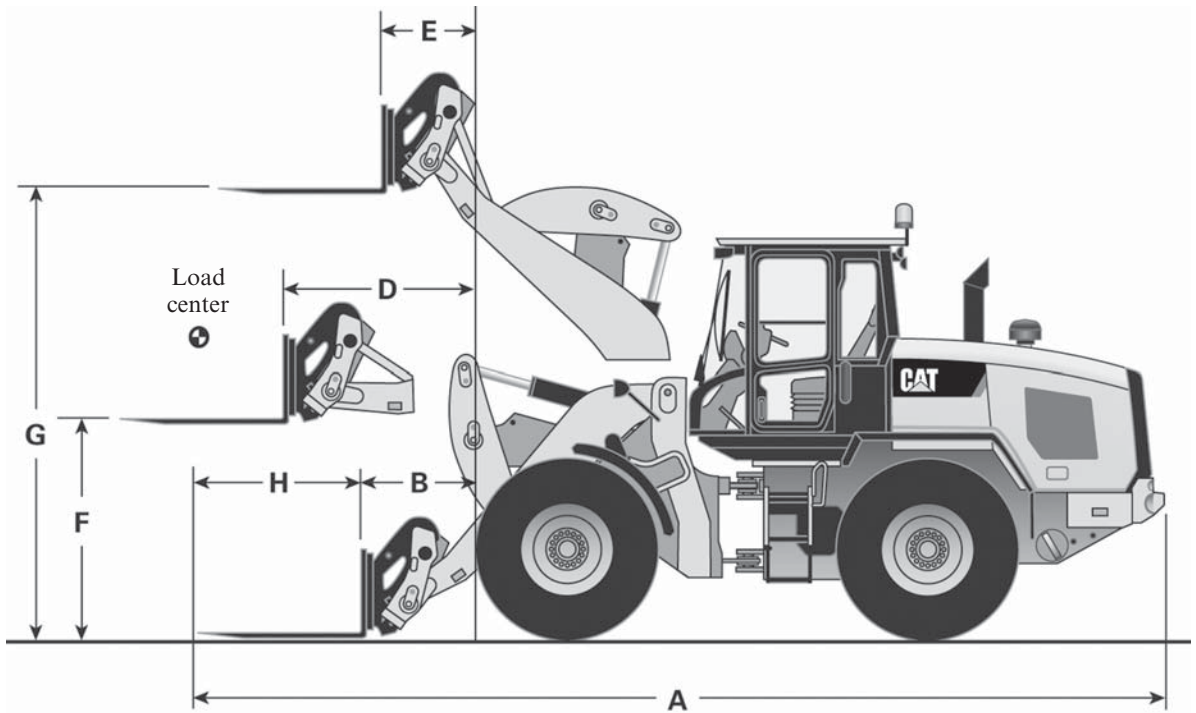

Dimensions listed are for a machine configured with Fusion coupler, heavy counterweight, additional guarding, 80 kg (176 lb) operator, and Michelin 20.5 R25 (L-3) XHA2 tires.

MODEL	930M* Standard					
Rated operating load						
Per SAE J1197	3289 kg	<b>7250 lb</b>	3195 kg	<b>7043 lb</b>	3103 kg	<b>6840 lb</b>
Per CEN 474-3 rough terrain	3946 kg	<b>8699 lb</b>	3833 kg	<b>8450 lb</b>	3723 kg	<b>8207 lb</b>
Per CEN 474-3 firm level ground	5262 kg	<b>11,600 lb</b>	5111 kg	<b>11,267 lb</b>	4964 kg	<b>10,943 lb</b>
<b>A</b> Maximum overall length	7882 mm	<b>25'10"</b>	8032 mm	<b>26'4"</b>	8186 mm	<b>26'10"</b>
<b>B</b> Reach with forks at ground level	926 mm	<b>3'0"</b>	926 mm	<b>3'0"</b>	926 mm	<b>3'0"</b>
<b>C</b> Load center	610 mm	<b>2'0"</b>	685 mm	<b>2'3"</b>	762 mm	<b>2'6"</b>
<b>D</b> Reach with arms horizontal and forks level	1569 mm	<b>5'2"</b>	1569 mm	<b>5'2"</b>	1569 mm	<b>5'2"</b>
<b>E</b> Reach with forks at maximum height	767 mm	<b>2'6"</b>	767 mm	<b>2'6"</b>	767 mm	<b>2'6"</b>
<b>F</b> Arms horizontal and forks level	1792 mm	<b>5'11"</b>	1792 mm	<b>5'11"</b>	1792 mm	<b>5'11"</b>
<b>G</b> Ground to top of tine at maximum height	3693 mm	<b>12'1"</b>	3693 mm	<b>12'1"</b>	3693 mm	<b>12'1"</b>
<b>H</b> Fork tine length	1220 mm	<b>4'0"</b>	1370 mm	<b>4'6"</b>	1524 mm	<b>5'0"</b>
Tires	<b>20.5 R25 (L-3) XHA2</b>		<b>20.5 R25 (L-3) XHA2</b>		<b>20.5 R25 (L-3) XHA2</b>	

\*Meets Tier 4 Final/Stage IV/Japan 2014 (Tier 4 Final) emission standards.

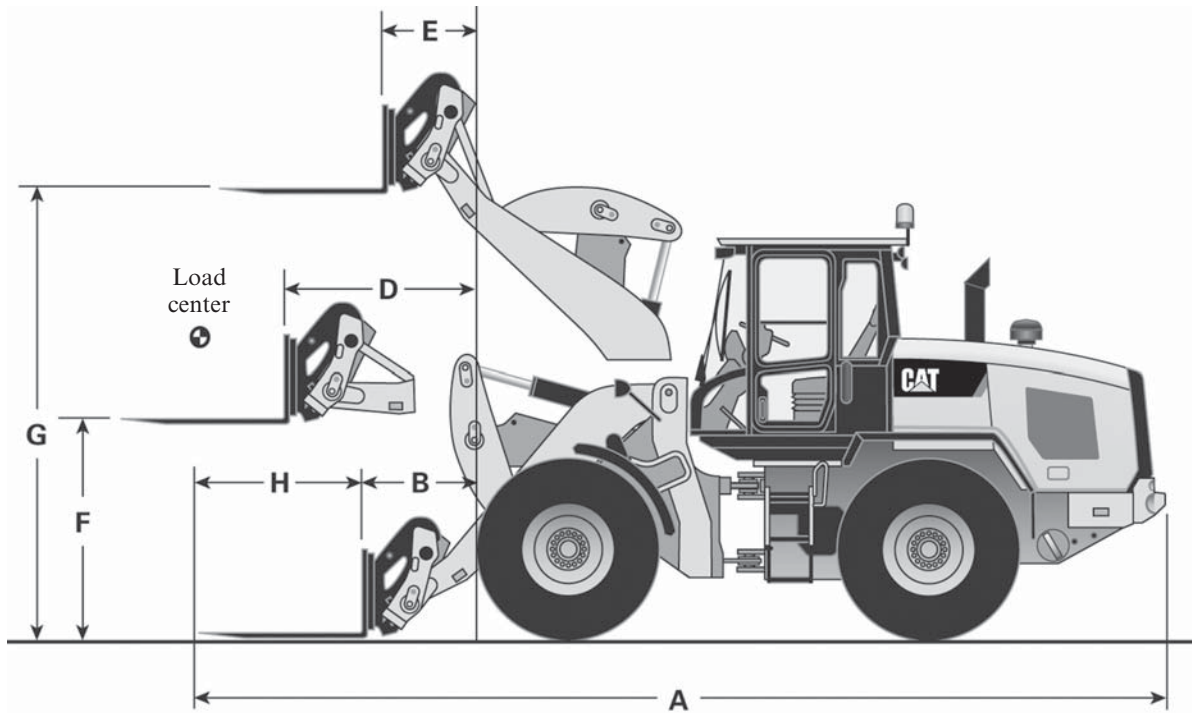

Dimensions listed are for a machine configured with Fusion coupler, heavy counterweight, additional guarding, 80 kg (176 lb) operator, and Michelin 20.5 R25 (L-3) XHA2 tires.

MODEL	930M* High Lift					
Rated operating load						
Per SAE J1197	2508 kg	<b>5529 lb</b>	2445 kg	<b>5390 lb</b>	2383 kg	<b>5254 lb</b>
Per CEN 474-3 rough terrain	3009 kg	<b>6634 lb</b>	2933 kg	<b>6466 lb</b>	2859 kg	<b>6303 lb</b>
Per CEN 474-3 firm level ground	4012 kg	<b>8845 lb</b>	3911 kg	<b>8622 lb</b>	3812 kg	<b>8404 lb</b>
<b>A</b> Maximum overall length	8689 mm	<b>28'6"</b>	8839 mm	<b>29'0"</b>	8993 mm	<b>29'6"</b>
<b>B</b> Reach with forks at ground level	1732 mm	<b>5'8"</b>	1732 mm	<b>5'8"</b>	1732 mm	<b>5'8"</b>
<b>C</b> Load center	610 mm	<b>2'0"</b>	685 mm	<b>2'3"</b>	762 mm	<b>2'6"</b>
<b>D</b> Reach with arms horizontal and forks level	2222 mm	<b>7'3"</b>	2222 mm	<b>7'3"</b>	2222 mm	<b>7'3"</b>
<b>E</b> Reach with forks at maximum height	1087 mm	<b>3'7"</b>	1087 mm	<b>3'7"</b>	1087 mm	<b>3'7"</b>
<b>F</b> Arms horizontal and forks level	1792 mm	<b>5'11"</b>	1792 mm	<b>5'11"</b>	1792 mm	<b>5'11"</b>
<b>G</b> Ground to top of tine at maximum height	4286 mm	<b>14'1"</b>	4286 mm	<b>14'1"</b>	4286 mm	<b>14'1"</b>
<b>H</b> Fork tine length	1220 mm	<b>4'0"</b>	1370 mm	<b>4'6"</b>	1554 mm	<b>5'1"</b>
Tires	<b>20.5 R25 (L-3) XHA2</b>		<b>20.5 R25 (L-3) XHA2</b>		<b>20.5 R25 (L-3) XHA2</b>	

\*Meets Tier 4 Final/Stage IV/Japan 2014 (Tier 4 Final) emission standards.

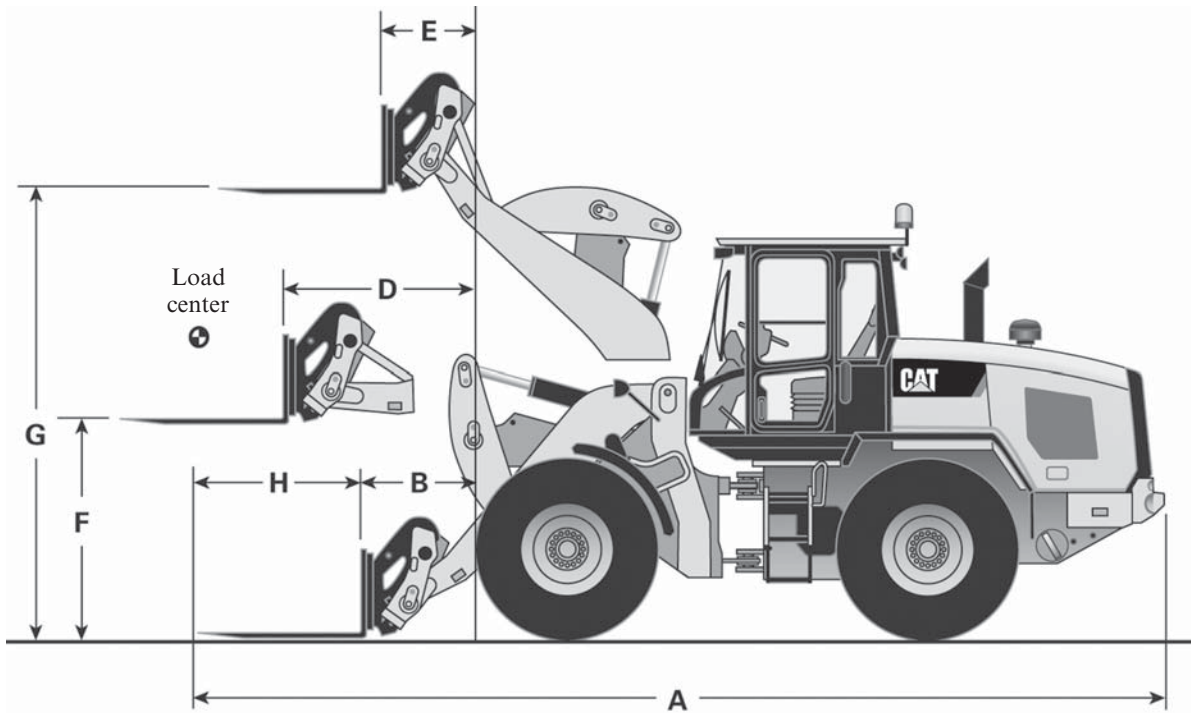

Dimensions listed are for a machine configured with Fusion coupler, heavy counterweight, additional guarding, 80 kg (176 lb) operator, and Michelin 20.5 R25 (L-3) XHA2 tires.

MODEL	938M*					
	Standard					
Rated operating load						
Per SAE J1197	3955 kg	<b>8719 lb</b>	3846 kg	<b>8479 lb</b>	3739 kg	<b>8243 lb</b>
Per CEN 474-3 rough terrain	4745 kg	<b>10,461 lb</b>	4615 kg	<b>10,174 lb</b>	4487 kg	<b>9892 lb</b>
Per CEN 474-3 firm level ground	6327 kg	<b>13,949 lb</b>	6154 kg	<b>13,567 lb</b>	5982 kg	<b>13,188 lb</b>
<b>A</b> Maximum overall length	7942 mm	<b>26'1"</b>	8092 mm	<b>26'7"</b>	8246 mm	<b>27'1"</b>
<b>B</b> Reach with forks at ground level	961 mm	<b>3'2"</b>	961 mm	<b>3'2"</b>	961 mm	<b>3'2"</b>
<b>C</b> Load center	610 mm	<b>2'0"</b>	685 mm	<b>2'3"</b>	762 mm	<b>2'6"</b>
<b>D</b> Reach with arms horizontal and forks level	1617 mm	<b>5'4"</b>	1617 mm	<b>5'4"</b>	1617 mm	<b>5'4"</b>
<b>E</b> Reach with forks at maximum height	814 mm	<b>2'8"</b>	814 mm	<b>2'8"</b>	814 mm	<b>2'8"</b>
<b>F</b> Arms horizontal and forks level	1830 mm	<b>6'0"</b>	1830 mm	<b>6'0"</b>	1830 mm	<b>6'0"</b>
<b>G</b> Ground to top of tine at maximum height	3758 mm	<b>12'4"</b>	3758 mm	<b>12'4"</b>	3758 mm	<b>12'4"</b>
<b>H</b> Fork tine length	1220 mm	<b>4'0"</b>	1370 mm	<b>4'6"</b>	1554 mm	<b>5'1"</b>
Tires	<b>20.5 R25 (L-3) XHA2</b>		<b>20.5 R25 (L-3) XHA2</b>		<b>20.5 R25 (L-3) XHA2</b>	

\*Meets Tier 4 Final/Stage IV/Japan 2014 (Tier 4 Final) emission standards.

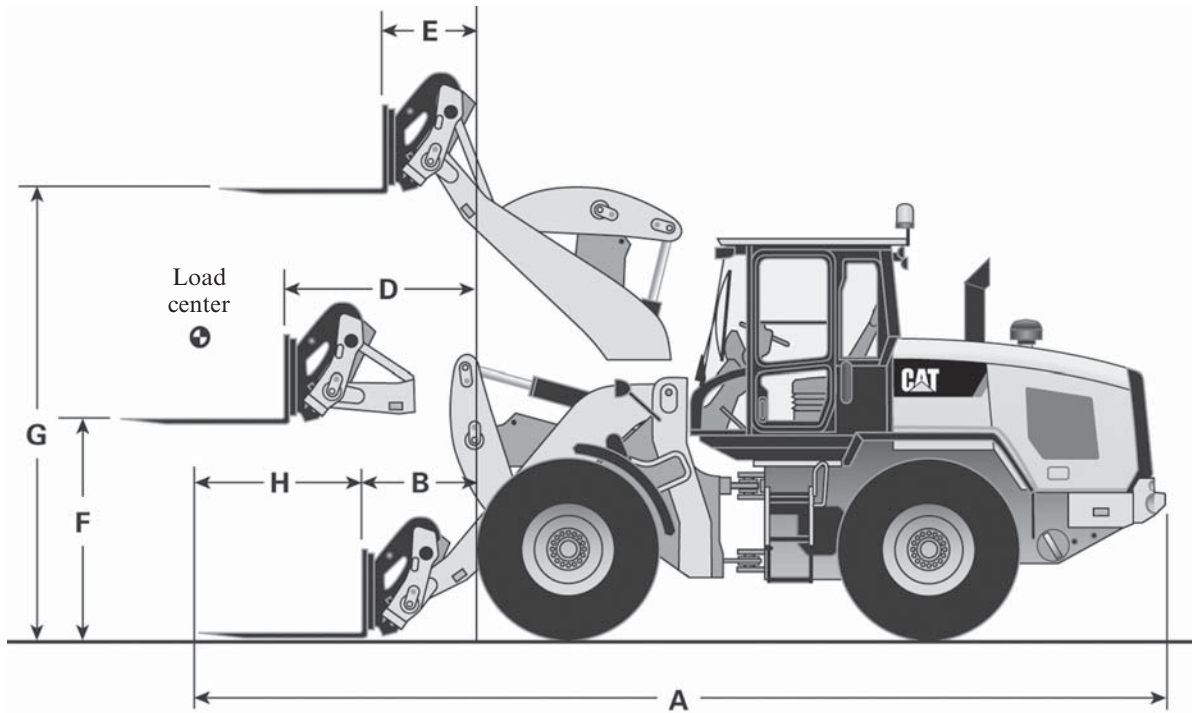

Dimensions listed are for a machine configured with Fusion coupler, heavy counterweight, additional guarding, 80 kg (176 lb) operator, and Michelin 20.5 R25 (L-3) XHA2 tires.

MODEL	938M* High Lift					
Rated operating load						
Per SAE J1197	2943 kg	<b>6488 lb</b>	2871 kg	<b>6329 lb</b>	2800 kg	<b>6173 lb</b>
Per CEN 474-3 rough terrain	3531 kg	<b>7785 lb</b>	3445 kg	<b>7595 lb</b>	3360 kg	<b>7408 lb</b>
Per CEN 474-3 firm level ground	4708 kg	<b>10,379 lb</b>	4594 kg	<b>10,128 lb</b>	4480 kg	<b>9877 lb</b>
<b>A</b> Maximum overall length	8695 mm	<b>28'6"</b>	8845 mm	<b>29'0"</b>	8999 mm	<b>29'6"</b>
<b>B</b> Reach with forks at ground level	1714 mm	<b>5'7"</b>	1714 mm	<b>5'7"</b>	1714 mm	<b>5'7"</b>
<b>C</b> Load center	610 mm	<b>2'0"</b>	685 mm	<b>2'3"</b>	762 mm	<b>2'6"</b>
<b>D</b> Reach with arms horizontal and forks level	2224 mm	<b>7'4"</b>	2224 mm	<b>7'4"</b>	2224 mm	<b>7'4"</b>
<b>E</b> Reach with forks at maximum height	1081 mm	<b>3'7"</b>	1081 mm	<b>3'7"</b>	1081 mm	<b>3'7"</b>
<b>F</b> Arms horizontal and forks level	1830 mm	<b>6'0"</b>	1830 mm	<b>6'0"</b>	1830 mm	<b>6'0"</b>
<b>G</b> Ground to top of tine at maximum height	4339 mm	<b>14'3"</b>	4339 mm	<b>14'3"</b>	4339 mm	<b>14'3"</b>
<b>H</b> Fork tine length	1220 mm	<b>4'0"</b>	1370 mm	<b>4'6"</b>	1554 mm	<b>5'1"</b>
Tires	<b>20.5 R25 (L-3) XHA2</b>		<b>20.5 R25 (L-3) XHA2</b>		<b>20.5 R25 (L-3) XHA2</b>	

\*Meets Tier 4 Final/Stage IV/Japan 2014 (Tier 4 Final) emission standards.

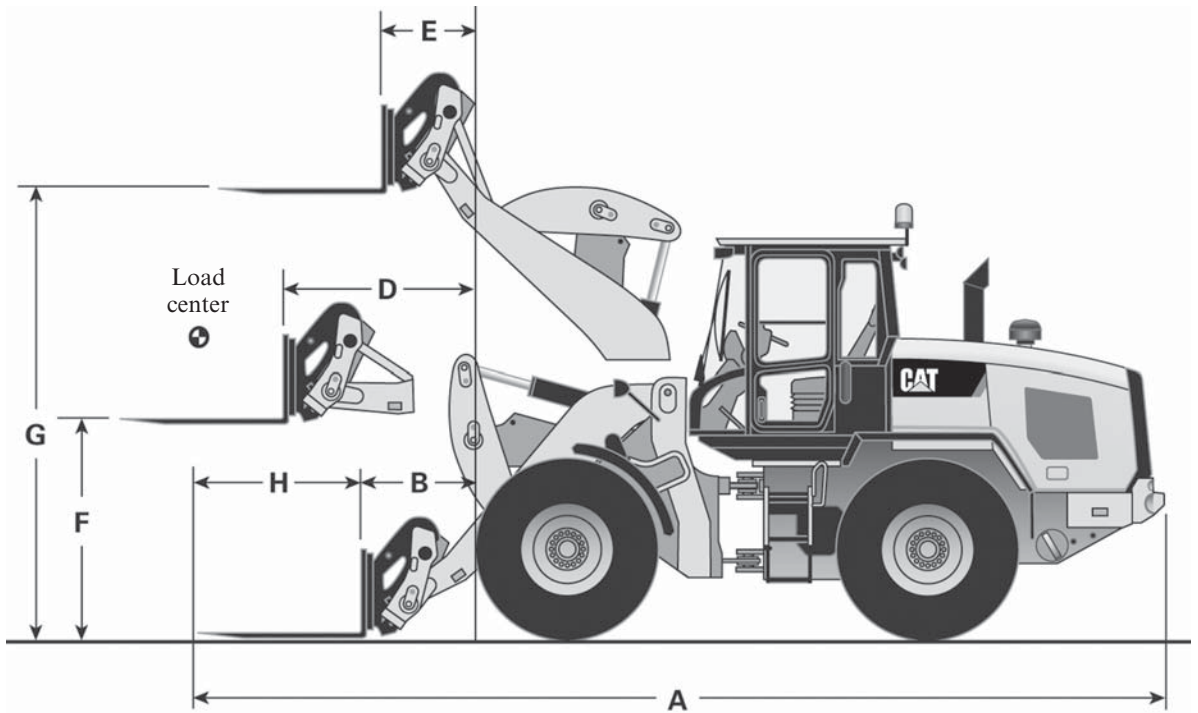

MODEL	924K Standard		930K Standard		938K Standard	
Rated operating load						
Per SAE J1197	2821 kg	<b>6218 lb</b>	3128 kg	<b>6893 lb</b>	3790 kg	<b>8352 lb</b>
Per CEN 474-3 rough terrain	3386 kg	<b>7462 lb</b>	3753 kg	<b>8272 lb</b>	4548 kg	<b>10,023 lb</b>
Per CEN 474-3 firm level ground	4514 kg	<b>9949 lb</b>	5004 kg	<b>11,029 lb</b>	6064 kg	<b>13,364 lb</b>
A Maximum overall length	7840 mm	<b>25'8"</b>	7882 mm	<b>25'10"</b>	7942 mm	<b>26'0"</b>
B Reach with forks at ground level	891 mm	<b>2'11"</b>	926 mm	<b>3'0"</b>	961 mm	<b>3'1"</b>
C Load center	610 mm	<b>2'0"</b>	610 mm	<b>2'0"</b>	610 mm	<b>2'0"</b>
D Reach with arms horizontal and forks level	1522 mm	<b>4'11"</b>	1569 mm	<b>5'1"</b>	1617 mm	<b>5'3"</b>
E Reach with fork at maximum height	724 mm	<b>2'4"</b>	767 mm	<b>2'6"</b>	814 mm	<b>2'8"</b>
F Arms horizontal and forks level	1761 mm	<b>5'9"</b>	1792 mm	<b>5'10"</b>	1830 mm	<b>6'0"</b>
G Ground to top of tine at maximum height	3639 mm	<b>11'11"</b>	3693 mm	<b>12'1"</b>	3758 mm	<b>12'3"</b>
H Fork tine length	1220 mm	<b>4'0"</b>	1220 mm	<b>4'0"</b>	1220 mm	<b>4'0"</b>
Tires	<b>Michelin 20.5 R25 (L-3) XHA2</b>		<b>Michelin 20.5 R25 (L-3) XHA2</b>		<b>Michelin 20.5 R25 (L-3) XHA2</b>	

NOTE: Fusion Pallet Forks



# Wheel Loaders Integrated Toolcarriers

# Machine Dimensions ● with Fusion Pallet Forks

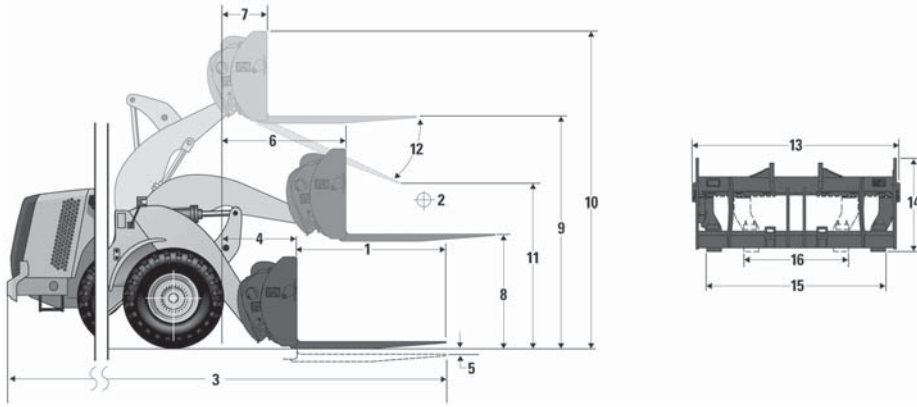

## MODEL

## 950M

1 Fork tine length	1524 mm	<b>60"</b>	1829 mm	<b>72"</b>	2134 mm	<b>84"</b>	2438 mm	<b>96"</b>
2 Load center	762 mm	<b>30"</b>	915 mm	<b>36"</b>	1067 mm	<b>42"</b>	1219 mm	<b>48"</b>
Tipping load — forks level straight	9190 kg	<b>20,255 lb</b>	8724 kg	<b>19,228 lb</b>	8291 kg	<b>18,273 lb</b>	7890 kg	<b>17,389 lb</b>
Tipping load — forks level articulated	7924 kg	<b>17,465 lb</b>	7513 kg	<b>16,560 lb</b>	7131 kg	<b>15,716 lb</b>	6776 kg	<b>14,934 lb</b>
Rated load (SAE J1197)†	3962 kg	<b>8733 lb</b>	3757 kg	<b>8280 lb</b>	3565 kg	<b>7858 lb</b>	3388 kg	<b>7467 lb</b>
Rated load (CEN EN 474-3 rough terrain)‡	4755 kg	<b>10,479 lb</b>	4508 kg	<b>9936 lb</b>	4278 kg	<b>9430 lb</b>	4066 kg	<b>8961 lb</b>
Rated load (CEN EN 474-3 firm and level ground)‡	6340 kg	<b>13,972 lb</b>	6011 kg	<b>13,248 lb</b>	5705 kg	<b>12,573 lb</b>	5378 kg	<b>11,854 lb</b>
3 Maximum overall length	8820 mm	<b>347.3"</b>	9125 mm	<b>359.3"</b>	9430 mm	<b>371.3"</b>	9734 mm	<b>383.2"</b>
4 Reach with forks at ground level	1198 mm	<b>47.2"</b>	1198 mm	<b>47.2"</b>	1198 mm	<b>47.2"</b>	1198 mm	<b>47.2"</b>
5 Ground to top of tine at minimum height and fork level	23 mm	<b>0.9"</b>	23 mm	<b>0.9"</b>	23 mm	<b>0.9"</b>	23 mm	<b>0.9"</b>
6 Reach with arms horizontal and forks level	1738 mm	<b>68.4"</b>	1738 mm	<b>68.4"</b>	1738 mm	<b>68.4"</b>	1738 mm	<b>68.4"</b>
7 Reach with fork at maximum height	1023 mm	<b>40.3"</b>	1023 mm	<b>40.3"</b>	1023 mm	<b>40.3"</b>	1023 mm	<b>40.3"</b>
8 Ground to top of tine with arms horizontal and fork level	1889 mm	<b>74.4"</b>	1889 mm	<b>74.4"</b>	1889 mm	<b>74.4"</b>	1889 mm	<b>74.4"</b>
9 Ground to top of tine at maximum height and fork level	3824 mm	<b>150.6"</b>	3824 mm	<b>150.6"</b>	3824 mm	<b>150.6"</b>	3824 mm	<b>150.6"</b>
10 Overall height of fork at full lift (top of carriage to ground)	4865 mm	<b>191.5"</b>	4865 mm	<b>191.5"</b>	4865 mm	<b>191.5"</b>	4865 mm	<b>191.5"</b>
11 Clearance at full lift and maximum dump	2284 mm	<b>89.9"</b>	2041 mm	<b>80.4"</b>	1798 mm	<b>70.8"</b>	1556 mm	<b>61.3"</b>
12 Maximum discharge angle from horizontal		<b>53°</b>		<b>53°</b>		<b>53°</b>		<b>53°</b>
13 Carriage width	2528 mm	<b>99.5"</b>	2528 mm	<b>99.5"</b>	2528 mm	<b>99.5"</b>	2528 mm	<b>99.5"</b>
14 Carriage height	1130 mm	<b>44.5"</b>	1130 mm	<b>44.5"</b>	1130 mm	<b>44.5"</b>	1130 mm	<b>44.5"</b>
15 Outside tine width (maximum spread)	2178 mm	<b>85.7"</b>	2178 mm	<b>85.7"</b>	2178 mm	<b>85.7"</b>	2178 mm	<b>85.7"</b>
16 Outside tine width (minimum spread)	576 mm	<b>22.7"</b>	576 mm	<b>22.7"</b>	576 mm	<b>22.7"</b>	576 mm	<b>22.7"</b>
Tine width (single tine)	180 mm	<b>7.1"</b>	180 mm	<b>7.1"</b>	180 mm	<b>7.1"</b>	180 mm	<b>7.1"</b>
Tine thickness	90 mm	<b>3.5"</b>	90 mm	<b>3.5"</b>	90 mm	<b>3.5"</b>	90 mm	<b>3.5"</b>
Tine capacity	17 800 kg	<b>39,231 lb</b>	14 800 kg	<b>32,619 lb</b>	12 700 kg	<b>27,991 lb</b>	11 300 kg	<b>24,905 lb</b>
Operating weight	19 277 kg	<b>42,487 lb</b>	19 339 kg	<b>42,624 lb</b>	19 402 kg	<b>42,763 lb</b>	19 464 kg	<b>42,899 lb</b>

Based on 2438 mm (96") carriage, Fusion coupler and Fusion pallet fork.

Static tipping loads and operating weight are based on the following loader configuration: L3 Michelin XHA tires, air conditioning, ride control, power train guard, full fluids, fuel tank, coolant, lubricants, and operator.

Specifications and ratings conform to the following standards: SAE\* J1197, SAE J732, CEN\*\* EN 474-3.

The rated operating load for a loader equipped with a pallet fork is determined by:

- SAE J1197: 50% of full turn static tipping load or hydraulic limit.
- CEN EN 474-3: 60% of full turn static tipping load on rough terrain or hydraulic limit.
- CEN EN 474-3: 80% of full turn static tipping load on firm and level ground or hydraulic limit.

\*SAE — Society of Automotive Engineers

\*\*CEN — European Committee for Standardization

†Rated load is determined by considering % of machine stability, hydraulic lift capacity, and hydraulic tilt capacity. Please contact your dealer to properly select the machine configuration for handling target payloads in your specific machine application.

Machine and work tool availability varies by region. Contact your local Cat dealer for product availability.

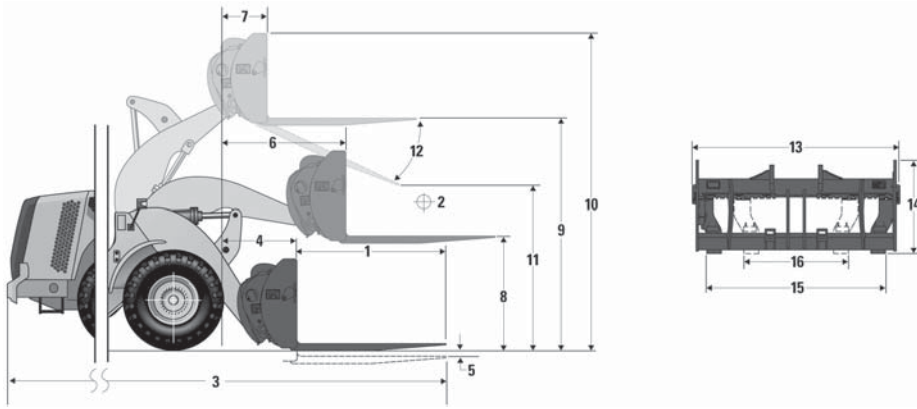

MODEL

962M

1 Fork tine length	1524 mm	60"	1829 mm	72"	2134 mm	84"	2438 mm	96"
2 Load center	762 mm	30"	915 mm	36"	1067 mm	42"	1219 mm	48"
Tipping load — forks level straight	10 165 kg	22,403 lb	9669 kg	21,310 lb	9207 kg	20,293 lb	8780 kg	19,350 lb
Tipping load — forks level articulated	8716 kg	19,211 lb	8282 kg	18,253 lb	7877 kg	17,361 lb	7501 kg	16,532 lb
Rated load (SAE J1197)†	4358 kg	9605 lb	4141 kg	9127 lb	3938 kg	8680 lb	3751 kg	8266 lb
Rated load (CEN EN 474-3 rough terrain)†	5230 kg	11,527 lb	4969 kg	10,952 lb	4726 kg	10,416 lb	4501 kg	9919 lb
Rated load (CEN EN 474-3 firm and level ground)†	6973 kg	15,369 lb	6626 kg	14,603 lb	6302 kg	13,889 lb	6001 kg	13,226 lb
3 Maximum overall length	9144 mm	360.0"	9449 mm	372.0"	9754 mm	384.0"	10 058 mm	396.0"
4 Reach with forks at ground level	1317 mm	51.8"	1317 mm	51.8"	1317 mm	51.8"	1317 mm	51.8"
5 Ground to top of tine at minimum height and fork level	24 mm	1.0"	24 mm	1.0"	24 mm	1.0"	24 mm	1.0"
6 Reach with arms horizontal and forks level	1836 mm	72.3"	1836 mm	72.3"	1836 mm	72.3"	1836 mm	72.3"
7 Reach with fork at maximum height	957 mm	37.7"	957 mm	37.7"	957 mm	37.7"	957 mm	37.7"
8 Ground to top of tine with arms horizontal and fork level	1889 mm	74.4"	1889 mm	74.4"	1889 mm	74.4"	1889 mm	74.4"
9 Ground to top of tine at maximum height and fork level	4041 mm	159.1"	4041 mm	159.1"	4041 mm	159.1"	4041 mm	159.1"
10 Overall height of fork at full lift (top of carriage to ground)	5081 mm	200.0"	5081 mm	200.0"	5081 mm	200.0"	5081 mm	200.0"
11 Clearance at full lift and maximum dump	2515 mm	99.0"	2274 mm	89.5"	2034 mm	80.1"	1794 mm	70.6"
12 Maximum discharge angle from horizontal		52°		52°		52°		52°
13 Carriage width	2528 mm	99.5"	2528 mm	99.5"	2528 mm	99.5"	2528 mm	99.5"
14 Carriage height	1130 mm	44.5"	1130 mm	44.5"	1130 mm	44.5"	1130 mm	44.5"
15 Outside tine width (maximum spread)	2178 mm	85.7"	2178 mm	85.7"	2178 mm	85.7"	2178 mm	85.7"
16 Outside tine width (minimum spread)	576 mm	22.7"	576 mm	22.7"	576 mm	22.7"	576 mm	22.7"
Tine width (single tine)	180 mm	7.1"	180 mm	7.1"	180 mm	7.1"	180 mm	7.1"
Tine thickness	90 mm	3.5"	90 mm	3.5"	90 mm	3.5"	90 mm	3.5"
Tine capacity	17 800 kg	39,231 lb	14 800 kg	32,619 lb	12 700 kg	27,991 lb	11 300 kg	24,905 lb
Operating weight	20 221 kg	44,566 lb	20 283 kg	44,703 lb	20 346 kg	44,842 lb	20 408 kg	44,979 lb

Based on 2438 mm (96") carriage, Fusion coupler and Fusion pallet fork.

Static tipping loads and operating weight are based on the following loader configuration: L3 Michelin XHA tires, air conditioning, ride control, power train guard, full fluids, fuel tank, coolant, lubricants, and operator.

Specifications and ratings conform to the following standards: SAE\* J1197, SAE J732, CEN\*\* EN 474-3.

The rated operating load for a loader equipped with a pallet fork is determined by:

- SAE J1197: 50% of full turn static tipping load or hydraulic limit.
- CEN EN 474-3: 60% of full turn static tipping load on rough terrain or hydraulic limit.
- CEN EN 474-3: 80% of full turn static tipping load on firm and level ground or hydraulic limit.

\*SAE — Society of Automotive Engineers

\*\*CEN — European Committee for Standardization

†Rated load is determined by considering % of machine stability, hydraulic lift capacity, and hydraulic tilt capacity. Please contact your dealer to properly select the machine configuration for handling target payloads in your specific machine application.

Machine and work tool availability varies by region. Contact your local Cat dealer for product availability.

# Wheel Loaders Integrated Toolcarriers

# Machine Dimensions ● with Fusion Pallet Forks

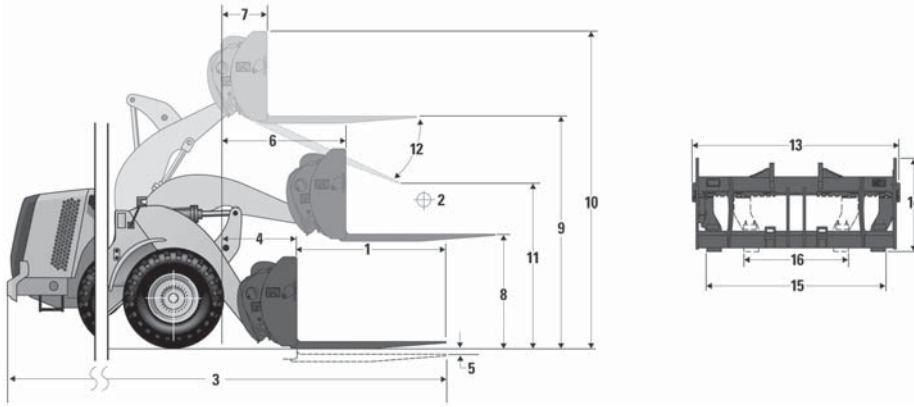

## MODEL

## 966L/966M

1 Fork tine length	1524 mm	<b>60"</b>	1829 mm	<b>72"</b>	2134 mm	<b>84"</b>	2438 mm	<b>96"</b>
2 Load center	762 mm	<b>30"</b>	915 mm	<b>36"</b>	1067 mm	<b>42"</b>	1219 mm	<b>48"</b>
Tipping load — forks level straight	11 924 kg	<b>26,280 lb</b>	11 345 kg	<b>25,003 lb</b>	10 807 kg	<b>23,819 lb</b>	10 310 kg	<b>22,723 lb</b>
Tipping load — forks level articulated	10 532 kg	<b>23,214 lb</b>	10 013 kg	<b>22,069 lb</b>	9531 kg	<b>21,006 lb</b>	9085 kg	<b>20,023 lb</b>
Rated load (SAE J1197)†	5266 kg	<b>11,607 lb</b>	5007 kg	<b>11,035 lb</b>	4766 kg	<b>10,503 lb</b>	4542 kg	<b>10,011 lb</b>
Rated load (CEN EN 474-3 rough terrain)†	6319 kg	<b>13,928 lb</b>	6008 kg	<b>13,242 lb</b>	5719 kg	<b>12,604 lb</b>	5451 kg	<b>12,014 lb</b>
Rated load (CEN EN 474-3 firm and level ground)†	8426 kg	<b>18,571 lb</b>	7807 kg	<b>17,207 lb</b>	6937 kg	<b>15,290 lb</b>	6222 kg	<b>13,712 lb</b>
3 Maximum overall length	9226 mm	<b>363.2"</b>	9531 mm	<b>375.2"</b>	9836 mm	<b>387.2"</b>	10 140 mm	<b>399.2"</b>
4 Reach with forks at ground level	1106 mm	<b>43.5"</b>	1106 mm	<b>43.5"</b>	1106 mm	<b>43.5"</b>	1106 mm	<b>43.5"</b>
5 Ground to top of tine at minimum height and fork level	-11 mm	<b>-0.5"</b>	-11 mm	<b>-0.5"</b>	-11 mm	<b>-0.5"</b>	-11 mm	<b>-0.5"</b>
6 Reach with arms horizontal and forks level	1704 mm	<b>67.1"</b>	1704 mm	<b>67.1"</b>	1704 mm	<b>67.1"</b>	1704 mm	<b>67.1"</b>
7 Reach with fork at maximum height	836 mm	<b>32.9"</b>	836 mm	<b>32.9"</b>	836 mm	<b>32.9"</b>	836 mm	<b>32.9"</b>
8 Ground to top of tine with arms horizontal and fork level	1955 mm	<b>77.0"</b>	1955 mm	<b>77.0"</b>	1955 mm	<b>77.0"</b>	1955 mm	<b>77.0"</b>
9 Ground to top of tine at maximum height and fork level	4039 mm	<b>159.0"</b>	4039 mm	<b>159.0"</b>	4039 mm	<b>159.0"</b>	4039 mm	<b>159.0"</b>
10 Overall height of fork at full lift (top of carriage to ground)	5079 mm	<b>200.0"</b>	5079 mm	<b>200.0"</b>	5079 mm	<b>200.0"</b>	5079 mm	<b>200.0"</b>
11 Clearance at full lift and maximum dump	2529 mm	<b>99.6"</b>	2292 mm	<b>90.2"</b>	2054 mm	<b>80.9"</b>	1818 mm	<b>71.6"</b>
12 Maximum discharge angle from horizontal		<b>51°</b>		<b>51°</b>		<b>51°</b>		<b>51°</b>
13 Carriage width	2528 mm	<b>99.5"</b>	2528 mm	<b>99.5"</b>	2528 mm	<b>99.5"</b>	2528 mm	<b>99.5"</b>
14 Carriage height	1130 mm	<b>44.5"</b>	1130 mm	<b>44.5"</b>	1130 mm	<b>44.5"</b>	1130 mm	<b>44.5"</b>
15 Outside tine width (maximum spread)	2178 mm	<b>85.7"</b>	2178 mm	<b>85.7"</b>	2178 mm	<b>85.7"</b>	2178 mm	<b>85.7"</b>
16 Outside tine width (minimum spread)	576 mm	<b>22.7"</b>	576 mm	<b>22.7"</b>	576 mm	<b>22.7"</b>	576 mm	<b>22.7"</b>
Tine width (single tine)	180 mm	<b>7.1"</b>	180 mm	<b>7.1"</b>	180 mm	<b>7.1"</b>	180 mm	<b>7.1"</b>
Tine thickness	90 mm	<b>3.5"</b>	90 mm	<b>3.5"</b>	90 mm	<b>3.5"</b>	90 mm	<b>3.5"</b>
Tine capacity	17 800 kg	<b>39,231 lb</b>	14 800 kg	<b>32,619 lb</b>	12 700 kg	<b>27,991 lb</b>	11 300 kg	<b>24,905 lb</b>
Operating weight	22 621 kg	<b>49,857 lb</b>	22 683 kg	<b>49,994 lb</b>	22 746 kg	<b>50,133 lb</b>	22 808 kg	<b>50,270 lb</b>

Based on 2438 mm (96") carriage, Fusion coupler and Fusion pallet fork.

Static tipping loads and operating weight are based on the following loader configuration: L3 Michelin XHA tires, air conditioning, ride control, power train guard, full fluids, fuel tank, coolant, lubricants, and operator.

Specifications and ratings conform to the following standards: SAE\* J1197, SAE J732, CEN\*\* EN 474-3.

The rated operating load for a loader equipped with a pallet fork is determined by:

- SAE J1197: 50% of full turn static tipping load or hydraulic limit.
- CEN EN 474-3: 60% of full turn static tipping load on rough terrain or hydraulic limit.
- CEN EN 474-3: 80% of full turn static tipping load on firm and level ground or hydraulic limit.

\*SAE — Society of Automotive Engineers

\*\*CEN — European Committee for Standardization

†Rated load is determined by considering % of machine stability, hydraulic lift capacity, and hydraulic tilt capacity. Please contact your dealer to properly select the machine configuration for handling target payloads in your specific machine application.

Machine and work tool availability varies by region. Contact your local Cat dealer for product availability.

## Machine Dimensions ● with Fusion Pallet Forks

## Wheel Loaders Integrated Toolcarriers

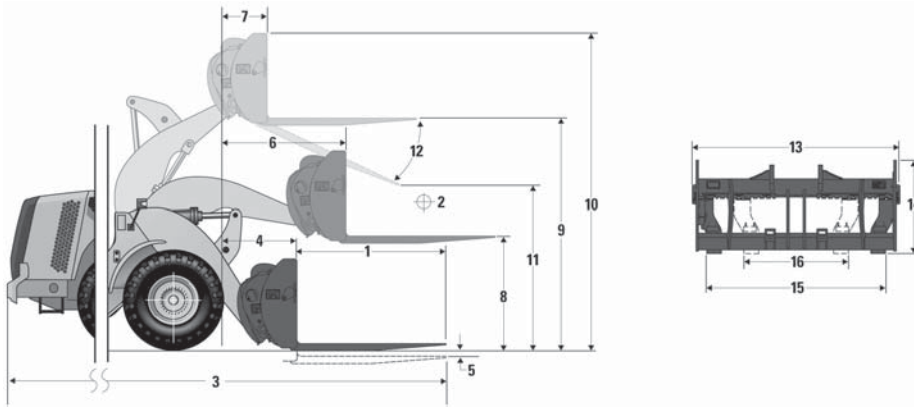

### MODEL

### 972L/972M

<b>1</b> Fork tine length	1524 mm	<b>60"</b>	1829 mm	<b>72"</b>	2134 mm	<b>84"</b>	2438 mm	<b>96"</b>
<b>2</b> Load center	762 mm	<b>30"</b>	915 mm	<b>36"</b>	1067 mm	<b>42"</b>	1219 mm	<b>48"</b>
Tipping load — forks level straight	13 644 kg	<b>30,071 lb</b>	13 012 kg	<b>28,679 lb</b>	12 425 kg	<b>27,385 lb</b>	11 881 kg	<b>26,185 lb</b>
Tipping load — forks level articulated	11 963 kg	<b>26,366 lb</b>	11 401 kg	<b>25,129 lb</b>	10 879 kg	<b>23,977 lb</b>	10 394 kg	<b>22,909 lb</b>
Rated load (SAE J1197)†	5981 kg	<b>13,183 lb</b>	5701 kg	<b>12,564 lb</b>	5439 kg	<b>11,988 lb</b>	5197 kg	<b>11,454 lb</b>
Rated load (CEN EN 474-3 rough terrain)†	7178 kg	<b>15,820 lb</b>	6841 kg	<b>15,077 lb</b>	6527 kg	<b>14,386 lb</b>	6237 kg	<b>13,745 lb</b>
Rated load (CEN EN 474-3 firm and level ground)†	9570 kg	<b>21,093 lb</b>	9121 kg	<b>20,103 lb</b>	8703 kg	<b>19,182 lb</b>	8315 kg	<b>18,327 lb</b>
<b>3</b> Maximum overall length	9707 mm	<b>382.2"</b>	10 012 mm	<b>394.2"</b>	10 317 mm	<b>406.2"</b>	10 621 mm	<b>418.1"</b>
<b>4</b> Reach with forks at ground level	1267 mm	<b>49.9"</b>	1267 mm	<b>49.9"</b>	1267 mm	<b>49.9"</b>	1267 mm	<b>49.9"</b>
<b>5</b> Ground to top of tine at minimum height and fork level	10 mm	<b>0.4"</b>	10 mm	<b>0.4"</b>	10 mm	<b>0.4"</b>	10 mm	<b>0.4"</b>
<b>6</b> Reach with arms horizontal and forks level	1834 mm	<b>72.2"</b>	1834 mm	<b>72.2"</b>	1834 mm	<b>72.2"</b>	1834 mm	<b>72.2"</b>
<b>7</b> Reach with fork at maximum height	788 mm	<b>31.0"</b>	788 mm	<b>31.0"</b>	788 mm	<b>31.0"</b>	788 mm	<b>31.0"</b>
<b>8</b> Ground to top of tine with arms horizontal and fork level	1956 mm	<b>77.0"</b>	1956 mm	<b>77.0"</b>	1956 mm	<b>77.0"</b>	1956 mm	<b>77.0"</b>
<b>9</b> Ground to top of tine at maximum height and fork level	4262 mm	<b>167.8"</b>	4262 mm	<b>167.8"</b>	4262 mm	<b>167.8"</b>	4262 mm	<b>167.8"</b>
<b>10</b> Overall height of fork at full lift (top of carriage to ground)	5302 mm	<b>208.8"</b>	5302 mm	<b>208.8"</b>	5302 mm	<b>208.8"</b>	5302 mm	<b>208.8"</b>
<b>11</b> Clearance at full lift and maximum dump	2753 mm	<b>108.4"</b>	2516 mm	<b>99.0"</b>	2278 mm	<b>89.7"</b>	2042 mm	<b>80.4"</b>
<b>12</b> Maximum discharge angle from horizontal		<b>51°</b>		<b>51°</b>		<b>51°</b>		<b>51°</b>
<b>13</b> Carriage width	2528 mm	<b>99.5"</b>	2528 mm	<b>99.5"</b>	2528 mm	<b>99.5"</b>	2528 mm	<b>99.5"</b>
<b>14</b> Carriage height	1130 mm	<b>44.5"</b>	1130 mm	<b>44.5"</b>	1130 mm	<b>44.5"</b>	1130 mm	<b>44.5"</b>
<b>15</b> Outside tine width (maximum spread)	2178 mm	<b>85.7"</b>	2178 mm	<b>85.7"</b>	2178 mm	<b>85.7"</b>	2178 mm	<b>85.7"</b>
<b>16</b> Outside tine width (minimum spread)	576 mm	<b>22.7"</b>	576 mm	<b>22.7"</b>	576 mm	<b>22.7"</b>	576 mm	<b>22.7"</b>
Tine width (single tine)	180 mm	<b>7.1"</b>	180 mm	<b>7.1"</b>	180 mm	<b>7.1"</b>	180 mm	<b>7.1"</b>
Tine thickness	90 mm	<b>3.5"</b>	90 mm	<b>3.5"</b>	90 mm	<b>3.5"</b>	90 mm	<b>3.5"</b>
Tine capacity	17 800 kg	<b>39,231 lb</b>	14 800 kg	<b>32,619 lb</b>	12 700 kg	<b>27,991 lb</b>	11 300 kg	<b>24,905 lb</b>
Operating weight	24 316 kg	<b>53,592 lb</b>	24 378 kg	<b>53,729 lb</b>	24 441 kg	<b>53,868 lb</b>	24 503 kg	<b>54,004 lb</b>

Based on 2438 mm (96") carriage, Fusion coupler and Fusion pallet fork.

Static tipping loads and operating weight are based on the following loader configuration: L3 Michelin XHA tires, air conditioning, ride control, power train guard, full fluids, fuel tank, coolant, lubricants, and operator.

Specifications and ratings conform to the following standards: SAE\* J1197, SAE J732, CEN\*\* EN 474-3.

The rated operating load for a loader equipped with a pallet fork is determined by:

- SAE J1197: 50% of full turn static tipping load or hydraulic limit.
- CEN EN 474-3: 60% of full turn static tipping load on rough terrain or hydraulic limit.
- CEN EN 474-3: 80% of full turn static tipping load on firm and level ground or hydraulic limit.

\*SAE — Society of Automotive Engineers

\*\*CEN — European Committee for Standardization

†Rated load is determined by considering % of machine stability, hydraulic lift capacity, and hydraulic tilt capacity. Please contact your dealer to properly select the machine configuration for handling target payloads in your specific machine application.

Machine and work tool availability varies by region. Contact your local Cat dealer for product availability.

# Wheel Loaders Integrated Toolcarriers

# Machine Dimensions ● with HPL Pallet Forks

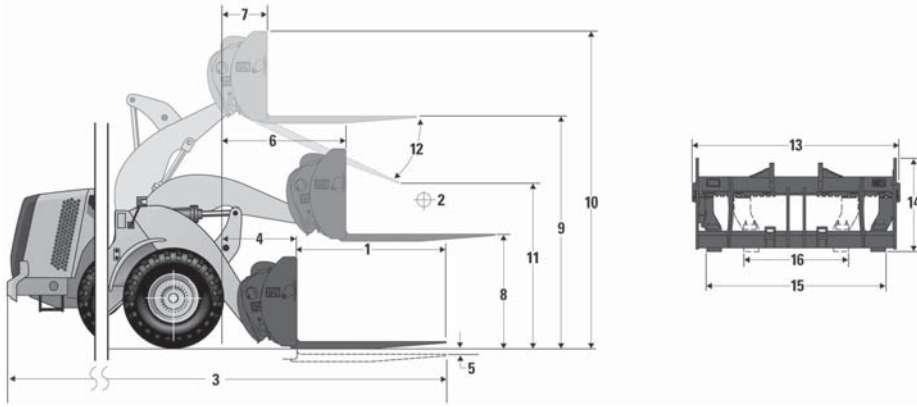

## MODEL

## 980L/980M

1 Fork tine length	1829 mm	72"	2134 mm	84"	2438 mm	96"
2 Load center	914 mm	36"	1067 mm	42"	1219 mm	48"
Tipping load — forks level straight	13 515 kg	29,788 lb	12 913 kg	28,460 lb	12 315 kg	27,142 lb
Tipping load — forks level articulated	11 655 kg	25,687 lb	11 123 kg	24,515 lb	10 591 kg	23,343 lb
Rated load (SAE J1197)†	5827 kg	12,844 lb	5562 kg	12,258 lb	5296 kg	11,671 lb
Rated load (CEN EN 474-3 rough terrain)†	6993 kg	15,412 lb	6674 kg	14,709 lb	6033 kg	13,296 lb
Rated load (CEN EN 474-3 firm and level ground)†	7479 kg	16,483 lb	6718 kg	14,807 lb	6033 kg	13,296 lb
3 Maximum overall length	10 412 mm	409.9"	10 717 mm	421.9"	11 022 mm	433.9"
4 Reach with forks at ground level	1385 mm	54.5"	1385 mm	54.5"	1385 mm	54.5"
5 Ground to top of tine at minimum height and fork level	-42 mm	-1.7"	-42 mm	-1.7"	-42 mm	-1.7"
6 Reach with arms horizontal and forks level	1991 mm	78.4"	1991 mm	78.4"	1991 mm	78.4"
7 Reach with fork at maximum height	1065 mm	41.9"	1065 mm	41.9"	1065 mm	41.9"
8 Ground to top of tine with arms horizontal and fork level	2067 mm	81.4"	2067 mm	81.4"	2067 mm	81.4"
9 Ground to top of tine at maximum height and fork level	4335 mm	170.7"	4335 mm	170.7"	4335 mm	170.7"
10 Overall height of fork at full lift (top of carriage to ground)	5827 mm	229.4"	5827 mm	229.4"	5827 mm	229.4"
11 Clearance at full lift and maximum dump	2324 mm	91.5"	2074 mm	81.7"	1825 mm	71.8"
12 Maximum discharge angle from horizontal		55°		55°		55°
13 Carriage width	2852 mm	112.3"	2852 mm	112.3"	2852 mm	112.3"
14 Carriage height	1581 mm	62.3"	1581 mm	62.3"	1581 mm	62.3"
15 Outside tine width (maximum spread)	2670 mm	105.1"	2670 mm	105.1"	2670 mm	105.1"
16 Outside tine width (minimum spread)	850 mm	33.5"	850 mm	33.5"	850 mm	33.5"
Tine width (single tine)	200 mm	7.9"	200 mm	7.9"	200 mm	7.9"
Tine thickness	90 mm	3.5"	90 mm	3.5"	90 mm	3.5"
Tine capacity	14 764 kg	32,540 lb	12 656 kg	27,894 lb	11 068 kg	24,394 lb
Operating weight	29 610 kg	65,260 lb	29 696 kg	65,450 lb	29 807 kg	65,694 lb

Static tipping loads and operating weight are based on the following loader configuration: L3 Michelin XHA tires, air conditioning, ride control, power train guard, full fluids, fuel tank, coolant, lubricants, and operator.

Specifications and ratings conform to the following standards: SAE\* J1197, SAE J732, CEN\*\* EN 474-3.

The rated operating load for a loader equipped with a pallet fork is determined by:

- SAE J1197: 50% of full turn static tipping load or hydraulic limit.
- CEN EN 474-3: 60% of full turn static tipping load on rough terrain or hydraulic limit.
- CEN EN 474-3: 80% of full turn static tipping load on firm and level ground or hydraulic limit.

\*SAE — Society of Automotive Engineers

\*\*CEN — European Committee for Standardization

†Rated load is determined by considering % of machine stability, hydraulic lift capacity, and hydraulic tilt capacity. Please contact your dealer to properly select the machine configuration for handling target payloads in your specific machine application.

Machine and work tool availability varies by region. Contact your local Cat dealer for product availability.

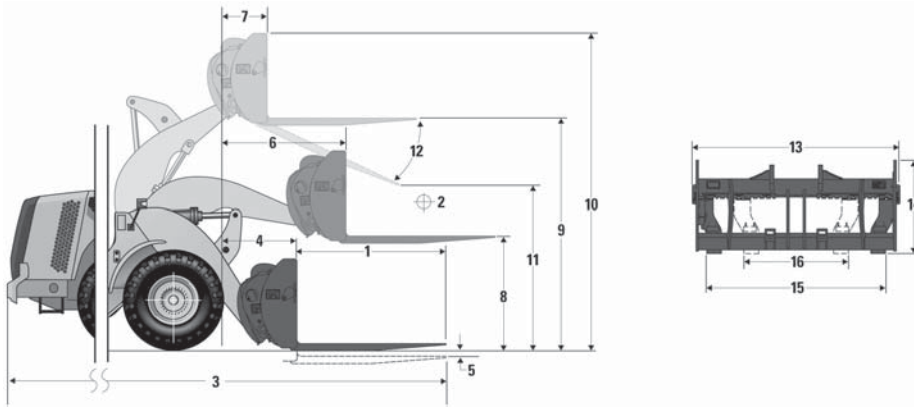

MODEL

950K

1 Fork tine length	1524 mm	60"	1829 mm	72"	2134 mm	84"	2438 mm	96"
2 Load center	762 mm	30"	915 mm	36"	1067 mm	42"	1219 mm	48"
Tipping load — forks level straight	9232 kg	<b>20,347 lb</b>	8763 kg	<b>19,313 lb</b>	8327 kg	<b>18,353 lb</b>	7924 kg	<b>17,464 lb</b>
Tipping load — forks level articulated	7985 kg	<b>17,599 lb</b>	7570 kg	<b>16,685 lb</b>	7185 kg	<b>15,835 lb</b>	6827 kg	<b>15,047 lb</b>
Rated load (SAE J1197)†	3993 kg	<b>8800 lb</b>	3785 kg	<b>8343 lb</b>	3592 kg	<b>7917 lb</b>	3414 kg	<b>7523 lb</b>
Rated load (CEN EN 474-3 rough terrain)†	4791 kg	<b>10,559 lb</b>	4542 kg	<b>10,011 lb</b>	4311 kg	<b>9501 lb</b>	4096 kg	<b>9028 lb</b>
Rated load (CEN EN 474-3 firm and level ground)†	6388 kg	<b>14,079 lb</b>	6056 kg	<b>13,348 lb</b>	5748 kg	<b>12,668 lb</b>	5424 kg	<b>11,954 lb</b>
3 Maximum overall length	8774 mm	<b>345.4"</b>	9079 mm	<b>357.4"</b>	9384 mm	<b>369.4"</b>	9688 mm	<b>381.4"</b>
4 Reach with forks at ground level	1189 mm	<b>46.8"</b>	1189 mm	<b>46.8"</b>	1189 mm	<b>46.8"</b>	1189 mm	<b>46.8"</b>
5 Ground to top of tine at minimum height and fork level	68 mm	<b>2.7"</b>	68 mm	<b>2.7"</b>	68 mm	<b>2.7"</b>	68 mm	<b>2.7"</b>
6 Reach with arms horizontal and forks level	1728 mm	<b>68.0"</b>	1728 mm	<b>68.0"</b>	1728 mm	<b>68.0"</b>	1728 mm	<b>68.0"</b>
7 Reach with fork at maximum height	1013 mm	<b>39.9"</b>	1013 mm	<b>39.9"</b>	1013 mm	<b>39.9"</b>	1013 mm	<b>39.9"</b>
8 Ground to top of tine with arms horizontal and fork level	1798 mm	<b>70.8"</b>	1798 mm	<b>70.8"</b>	1798 mm	<b>70.8"</b>	1798 mm	<b>70.8"</b>
9 Ground to top of tine at maximum height and fork level	3733 mm	<b>147.0"</b>	3733 mm	<b>147.0"</b>	3733 mm	<b>147.0"</b>	3733 mm	<b>147.0"</b>
10 Overall height of fork at full lift (top of carriage to ground)	4863 mm	<b>191.5"</b>	4863 mm	<b>191.5"</b>	4863 mm	<b>191.5"</b>	4863 mm	<b>191.5"</b>
11 Clearance at full lift and maximum dump	2438 mm	<b>96.0"</b>	2222 mm	<b>87.5"</b>	2006 mm	<b>79.0"</b>	1792 mm	<b>70.5"</b>
12 Maximum discharge angle from horizontal		<b>45°</b>		<b>45°</b>		<b>45°</b>		<b>45°</b>
13 Carriage width	2528 mm	<b>99.5"</b>	2528 mm	<b>99.5"</b>	2528 mm	<b>99.5"</b>	2528 mm	<b>99.5"</b>
14 Carriage height	1220 mm	<b>48.0"</b>	1220 mm	<b>48.0"</b>	1220 mm	<b>48.0"</b>	1220 mm	<b>48.0"</b>
15 Outside tine width (maximum spread)	2178 mm	<b>85.7"</b>	2178 mm	<b>85.7"</b>	2178 mm	<b>85.7"</b>	2178 mm	<b>85.7"</b>
16 Outside tine width (minimum spread)	576 mm	<b>22.7"</b>	576 mm	<b>22.7"</b>	576 mm	<b>22.7"</b>	576 mm	<b>22.7"</b>
Tine width (single tine)	180 mm	<b>7.1"</b>	180 mm	<b>7.1"</b>	180 mm	<b>7.1"</b>	180 mm	<b>7.1"</b>
Tine thickness	90 mm	<b>3.5"</b>	90 mm	<b>3.5"</b>	90 mm	<b>3.5"</b>	90 mm	<b>3.5"</b>
Operating weight	19 445 kg	<b>42,857 lb</b>	19 507 kg	<b>42,994 lb</b>	19 570 kg	<b>43,133 lb</b>	19 632 kg	<b>43,269 lb</b>

Based on 2438 mm (96") carriage, Fusion coupler and Fusion pallet fork.

Static tipping loads and operating weight are based on the following loader configuration: L3 Michelin XHA tires, air conditioning, ride control, power train guard, full fluids, fuel tank, coolant, lubricants, and operator. Static tipping loads conform to the international standard as defined in ISO\* 14397-1 (Sept2007).

Specifications and ratings conform to the following standards: ISO 14397-1, SAE\*\* J1197, SAE J732, CEN\*\*\* EN 474-3.

The rated operating load for a loader equipped with a pallet fork is determined by:

- SAE J1197: 50% of full turn static tipping load or hydraulic limit.
- CEN EN 474-3: 60% of full turn static tipping load on rough terrain or hydraulic limit.
- CEN EN 474-3: 80% of full turn static tipping load on firm and level ground or hydraulic limit.

\*ISO — International Organization for Standardization

\*\*SAE — Society of Automotive Engineers

\*\*\*CEN — European Committee for Standardization

†Rated load is determined by considering % of machine stability, hydraulic lift capacity, and hydraulic tilt capacity. Please contact your dealer to properly select the machine configuration for handling target payloads in your specific machine application.

Machine and work tool availability varies by region. Contact your local Cat dealer for product availability.

# Wheel Loaders Integrated Toolcarriers

# Machine Dimensions ● with Fusion Pallet Forks

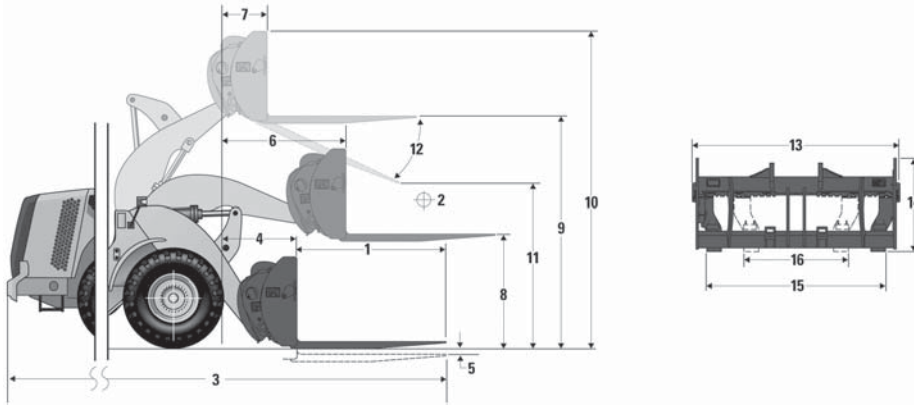

## MODEL

## 962K

1 Fork tine length	1524 mm	<b>60"</b>	1829 mm	<b>72"</b>	2134 mm	<b>84"</b>	2438 mm	<b>96"</b>
2 Load center	762 mm	<b>30"</b>	915 mm	<b>36"</b>	1067 mm	<b>42"</b>	1219 mm	<b>48"</b>
Tipping load — forks level straight	10 192 kg	<b>22,463 lb</b>	9694 kg	<b>21,366 lb</b>	9231 kg	<b>20,344 lb</b>	8801 kg	<b>19,398 lb</b>
Tipping load — forks level articulated	8767 kg	<b>19,322 lb</b>	8329 kg	<b>18,357 lb</b>	7921 kg	<b>17,458 lb</b>	7543 kg	<b>16,625 lb</b>
Rated load (SAE J1197)†	4383 kg	<b>9661 lb</b>	4165 kg	<b>9179 lb</b>	3961 kg	<b>8729 lb</b>	3771 kg	<b>8312 lb</b>
Rated load (CEN EN 474-3 rough terrain)†	5260 kg	<b>11,593 lb</b>	4997 kg	<b>11,014 lb</b>	4753 kg	<b>10,475 lb</b>	4526 kg	<b>9975 lb</b>
Rated load (CEN EN 474-3 firm and level ground)†	7013 kg	<b>15,457 lb</b>	6663 kg	<b>14,686 lb</b>	6337 kg	<b>13,967 lb</b>	6034 kg	<b>13,300 lb</b>
3 Maximum overall length	9042 mm	<b>356.0"</b>	9347 mm	<b>368.0"</b>	9652 mm	<b>380.0"</b>	9956 mm	<b>392.0"</b>
4 Reach with forks at ground level	1307 mm	<b>51.5"</b>	1307 mm	<b>51.5"</b>	1307 mm	<b>51.5"</b>	1307 mm	<b>51.5"</b>
5 Ground to top of tine at minimum height and fork level	67 mm	<b>2.6"</b>	67 mm	<b>2.6"</b>	67 mm	<b>2.6"</b>	67 mm	<b>2.6"</b>
6 Reach with arms horizontal and forks level	1826 mm	<b>71.9"</b>	1826 mm	<b>71.9"</b>	1826 mm	<b>71.9"</b>	1826 mm	<b>71.9"</b>
7 Reach with fork at maximum height	947 mm	<b>37.3"</b>	947 mm	<b>37.3"</b>	947 mm	<b>37.3"</b>	947 mm	<b>37.3"</b>
8 Ground to top of tine with arms horizontal and fork level	1798 mm	<b>70.8"</b>	1798 mm	<b>70.8"</b>	1798 mm	<b>70.8"</b>	1798 mm	<b>70.8"</b>
9 Ground to top of tine at maximum height and fork level	3950 mm	<b>155.5"</b>	3950 mm	<b>155.5"</b>	3950 mm	<b>155.5"</b>	3950 mm	<b>155.5"</b>
10 Overall height of fork at full lift (top of carriage to ground)	5080 mm	<b>200.0"</b>	5080 mm	<b>200.0"</b>	5080 mm	<b>200.0"</b>	5080 mm	<b>200.0"</b>
11 Clearance at full lift and maximum dump	2655 mm	<b>104.5"</b>	2439 mm	<b>96.0"</b>	2223 mm	<b>87.5"</b>	2008 mm	<b>79.1"</b>
12 Maximum discharge angle from horizontal		<b>45°</b>		<b>45°</b>		<b>45°</b>		<b>45°</b>
13 Carriage width	2528 mm	<b>99.5"</b>	2528 mm	<b>99.5"</b>	2528 mm	<b>99.5"</b>	2528 mm	<b>99.5"</b>
14 Carriage height	1220 mm	<b>48.0"</b>	1220 mm	<b>48.0"</b>	1220 mm	<b>48.0"</b>	1220 mm	<b>48.0"</b>
15 Outside tine width (maximum spread)	2178 mm	<b>85.7"</b>	2178 mm	<b>85.7"</b>	2178 mm	<b>85.7"</b>	2178 mm	<b>85.7"</b>
16 Outside tine width (minimum spread)	576 mm	<b>22.7"</b>	576 mm	<b>22.7"</b>	576 mm	<b>22.7"</b>	576 mm	<b>22.7"</b>
Tine width (single tine)	180 mm	<b>7.1"</b>	180 mm	<b>7.1"</b>	180 mm	<b>7.1"</b>	180 mm	<b>7.1"</b>
Tine thickness	90 mm	<b>3.5"</b>	90 mm	<b>3.5"</b>	90 mm	<b>3.5"</b>	90 mm	<b>3.5"</b>
Operating weight	20 394 kg	<b>44,948 lb</b>	20 456 kg	<b>45,084 lb</b>	20 519 kg	<b>45,223 lb</b>	20 581 kg	<b>45,360 lb</b>

Based on 2438 mm (96") carriage, Fusion coupler and Fusion pallet fork.

Static tipping loads and operating weight are based on the following loader configuration: L3 Michelin XHA tires, air conditioning, ride control, power train guard, full fluids, fuel tank, coolant, lubricants, and operator. Static tipping loads conform to the international standard as defined in ISO\* 14397-1 (Sept2007).

Specifications and ratings conform to the following standards: ISO 14397-1, SAE\*\* J1197, SAE J732, CEN\*\*\* EN 474-3.

†Rated load is determined by considering % of machine stability, hydraulic lift capacity, and hydraulic tilt capacity. Please contact your dealer to properly select the machine configuration for handling target payloads in your specific machine application.

Machine and work tool availability varies by region. Contact your local Cat dealer for product availability.

The rated operating load for a loader equipped with a pallet fork is determined by:

- SAE J1197: 50% of full turn static tipping load or hydraulic limit.
- CEN EN 474-3: 60% of full turn static tipping load on rough terrain or hydraulic limit.
- CEN EN 474-3: 80% of full turn static tipping load on firm and level ground or hydraulic limit.

\*ISO — International Organization for Standardization

\*\*SAE — Society of Automotive Engineers

\*\*\*CEN — European Committee for Standardization

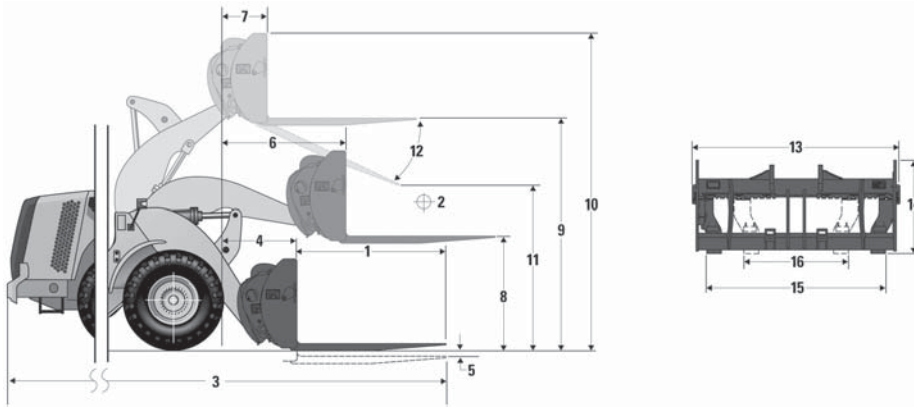

MODEL

966K

1 Fork tine length	1524 mm	60"	1829 mm	72"	2134 mm	84"	2438 mm	96"
2 Load center	762 mm	30"	915 mm	36"	1067 mm	42"	1219 mm	48"
Tipping load — forks level straight	12 045 kg	<b>26,548 lb</b>	11 464 kg	<b>25,267 lb</b>	10 925 kg	<b>24,079 lb</b>	10 426 kg	<b>22,979 lb</b>
Tipping load — forks level articulated	10 629 kg	<b>23,427 lb</b>	10 109 kg	<b>22,280 lb</b>	9625 kg	<b>21,214 lb</b>	9178 kg	<b>20,228 lb</b>
Rated load (SAE J1197)†	5315 kg	<b>11,713 lb</b>	5054 kg	<b>11,140 lb</b>	4813 kg	<b>10,607 lb</b>	4589 kg	<b>10,114 lb</b>
Rated load (CEN EN 474-3 rough terrain)†	6378 kg	<b>14,506 lb</b>	6065 kg	<b>13,368 lb</b>	5775 kg	<b>12,729 lb</b>	5507 kg	<b>12,137 lb</b>
Rated load (CEN EN 474-3 firm and level ground)†	8503 kg	<b>18,741 lb</b>	7806 kg	<b>17,205 lb</b>	6928 kg	<b>15,269 lb</b>	6207 kg	<b>13,681 lb</b>
3 Maximum overall length	9148 mm	<b>360.2"</b>	9453 mm	<b>372.2"</b>	9758 mm	<b>384.2"</b>	10 062 mm	<b>396.2"</b>
4 Reach with forks at ground level	1122 mm	<b>44.2"</b>	1122 mm	<b>44.2"</b>	1122 mm	<b>44.2"</b>	1122 mm	<b>44.2"</b>
5 Ground to top of tine at minimum height and fork level	97 mm	<b>3.8"</b>	97 mm	<b>3.8"</b>	97 mm	<b>3.8"</b>	97 mm	<b>3.8"</b>
6 Reach with arms horizontal and forks level	1723 mm	<b>67.9"</b>	1723 mm	<b>67.9"</b>	1723 mm	<b>67.9"</b>	1723 mm	<b>67.9"</b>
7 Reach with fork at maximum height	856 mm	<b>33.7"</b>	856 mm	<b>33.7"</b>	856 mm	<b>33.7"</b>	856 mm	<b>33.7"</b>
8 Ground to top of tine with arms horizontal and fork level	1870 mm	<b>73.6"</b>	1870 mm	<b>73.6"</b>	1870 mm	<b>73.6"</b>	1870 mm	<b>73.6"</b>
9 Ground to top of tine at maximum height and fork level	3953 mm	<b>155.6"</b>	3953 mm	<b>155.6"</b>	3953 mm	<b>155.6"</b>	3953 mm	<b>155.6"</b>
10 Overall height of fork at full lift (top of carriage to ground)	5083 mm	<b>200.1"</b>	5083 mm	<b>200.1"</b>	5083 mm	<b>200.1"</b>	5083 mm	<b>200.1"</b>
11 Clearance at full lift and maximum dump	2580 mm	<b>101.6"</b>	2349 mm	<b>92.5"</b>	2119 mm	<b>83.4"</b>	1889 mm	<b>74.4"</b>
12 Maximum discharge angle from horizontal		<b>49°</b>		<b>49°</b>		<b>49°</b>		<b>49°</b>
13 Carriage width	2528 mm	<b>99.5"</b>	2528 mm	<b>99.5"</b>	2528 mm	<b>99.5"</b>	2528 mm	<b>99.5"</b>
14 Carriage height	1220 mm	<b>48.0"</b>	1220 mm	<b>48.0"</b>	1220 mm	<b>48.0"</b>	1220 mm	<b>48.0"</b>
15 Outside tine width (maximum spread)	2178 mm	<b>85.7"</b>	2178 mm	<b>85.7"</b>	2178 mm	<b>85.7"</b>	2178 mm	<b>85.7"</b>
16 Outside tine width (minimum spread)	576 mm	<b>22.7"</b>	576 mm	<b>22.7"</b>	576 mm	<b>22.7"</b>	576 mm	<b>22.7"</b>
Tine width (single tine)	180 mm	<b>7.1"</b>	180 mm	<b>7.1"</b>	180 mm	<b>7.1"</b>	180 mm	<b>7.1"</b>
Tine thickness	90 mm	<b>3.5"</b>	90 mm	<b>3.5"</b>	90 mm	<b>3.5"</b>	90 mm	<b>3.5"</b>
Operating weight	23 588 kg	<b>51,988 lb</b>	23 650 kg	<b>52,124 lb</b>	23 713 kg	<b>52,263 lb</b>	23 775 kg	<b>52,400 lb</b>

Based on 2438 mm (96") carriage, Fusion coupler and Fusion pallet fork.

Static tipping loads and operating weight are based on the following loader configuration: L3 Michelin XHA tires, air conditioning, ride control, power train guard, full fluids, fuel tank, coolant, lubricants, and operator. Static tipping loads conform to the international standard as defined in ISO\* 14397-1 (Sept2007).

Specifications and ratings conform to the following standards: ISO 14397-1, SAE\*\* J1197, SAE J732, CEN\*\*\* EN 474-3.

The rated operating load for a loader equipped with a pallet fork is determined by:

- SAE J1197: 50% of full turn static tipping load or hydraulic limit.
- CEN EN 474-3: 60% of full turn static tipping load on rough terrain or hydraulic limit.
- CEN EN 474-3: 80% of full turn static tipping load on firm and level ground or hydraulic limit.

\*ISO — International Organization for Standardization

\*\*SAE — Society of Automotive Engineers

\*\*\*CEN — European Committee for Standardization

†Rated load is determined by considering % of machine stability, hydraulic lift capacity, and hydraulic tilt capacity. Please contact your dealer to properly select the machine configuration for handling target payloads in your specific machine application.

Machine and work tool availability varies by region. Contact your local Cat dealer for product availability.



# Wheel Loaders Integrated Toolcarriers

# Machine Dimensions ● with Fusion Pallet Forks

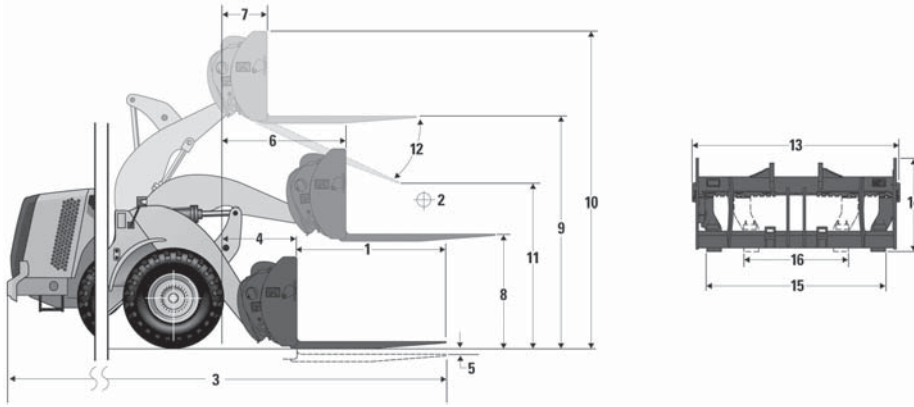

## MODEL

## 972K

1 Fork tine length	1524 mm	<b>60"</b>	1829 mm	<b>72"</b>	2134 mm	<b>84"</b>	2438 mm	<b>96"</b>
2 Load center	762 mm	<b>30"</b>	915 mm	<b>36"</b>	1067 mm	<b>42"</b>	1219 mm	<b>48"</b>
Tipping load — forks level straight	13 924 kg	<b>30,688 lb</b>	13 285 kg	<b>29,279 lb</b>	12 690 kg	<b>27,969 lb</b>	12 139 kg	<b>26,754 lb</b>
Tipping load — forks level articulated	12 202 kg	<b>26,894 lb</b>	11 634 kg	<b>25,642 lb</b>	11 105 kg	<b>24,476 lb</b>	10 615 kg	<b>23,395 lb</b>
Rated load (SAE J1197)†	6101 kg	<b>13,447 lb</b>	5817 kg	<b>12,821 lb</b>	5553 kg	<b>12,238 lb</b>	5307 kg	<b>11,697 lb</b>
Rated load (CEN EN 474-3 rough terrain)†	7321 kg	<b>16,136 lb</b>	6981 kg	<b>15,385 lb</b>	6663 kg	<b>14,686 lb</b>	6369 kg	<b>14,037 lb</b>
Rated load (CEN EN 474-3 firm and level ground)†	9762 kg	<b>21,515 lb</b>	9307 kg	<b>20,514 lb</b>	8884 kg	<b>19,581 lb</b>	8492 kg	<b>18,716 lb</b>
3 Maximum overall length	9597 mm	<b>377.8"</b>	9902 mm	<b>389.8"</b>	10 207 mm	<b>401.8"</b>	10 511 mm	<b>413.8"</b>
4 Reach with forks at ground level	1284 mm	<b>50.5"</b>	1284 mm	<b>50.5"</b>	1284 mm	<b>50.5"</b>	1284 mm	<b>50.5"</b>
5 Ground to top of tine at minimum height and fork level	75 mm	<b>3.0"</b>	75 mm	<b>3.0"</b>	75 mm	<b>3.0"</b>	75 mm	<b>3.0"</b>
6 Reach with arms horizontal and forks level	1854 mm	<b>73.0"</b>	1854 mm	<b>73.0"</b>	1854 mm	<b>73.0"</b>	1854 mm	<b>73.0"</b>
7 Reach with fork at maximum height	808 mm	<b>31.8"</b>	808 mm	<b>31.8"</b>	808 mm	<b>31.8"</b>	808 mm	<b>31.8"</b>
8 Ground to top of tine with arms horizontal and fork level	1871 mm	<b>73.6"</b>	1871 mm	<b>73.6"</b>	1871 mm	<b>73.6"</b>	1871 mm	<b>73.6"</b>
9 Ground to top of tine at maximum height and fork level	4177 mm	<b>164.4"</b>	4177 mm	<b>164.4"</b>	4177 mm	<b>164.4"</b>	4177 mm	<b>164.4"</b>
10 Overall height of fork at full lift (top of carriage to ground)	5307 mm	<b>208.9"</b>	5307 mm	<b>208.9"</b>	5307 mm	<b>208.9"</b>	5307 mm	<b>208.9"</b>
11 Clearance at full lift and maximum dump	2803 mm	<b>110.4"</b>	2573 mm	<b>101.3"</b>	2343 mm	<b>92.2"</b>	2113 mm	<b>83.2"</b>
12 Maximum discharge angle from horizontal		<b>49°</b>		<b>49°</b>		<b>49°</b>		<b>49°</b>
13 Carriage width	2528 mm	<b>99.5"</b>	2528 mm	<b>99.5"</b>	2528 mm	<b>99.5"</b>	2528 mm	<b>99.5"</b>
14 Carriage height	1220 mm	<b>48.0"</b>	1220 mm	<b>48.0"</b>	1220 mm	<b>48.0"</b>	1220 mm	<b>48.0"</b>
15 Outside tine width (maximum spread)	2178 mm	<b>85.7"</b>	2178 mm	<b>85.7"</b>	2178 mm	<b>85.7"</b>	2178 mm	<b>85.7"</b>
16 Outside tine width (minimum spread)	576 mm	<b>22.7"</b>	576 mm	<b>22.7"</b>	576 mm	<b>22.7"</b>	576 mm	<b>22.7"</b>
Tine width (single tine)	180 mm	<b>7.1"</b>	180 mm	<b>7.1"</b>	180 mm	<b>7.1"</b>	180 mm	<b>7.1"</b>
Tine thickness	90 mm	<b>3.5"</b>	90 mm	<b>3.5"</b>	90 mm	<b>3.5"</b>	90 mm	<b>3.5"</b>
Operating weight	25 629 kg	<b>56,486 lb</b>	25 691 kg	<b>56,623 lb</b>	25 754 kg	<b>56,762 lb</b>	25 816 kg	<b>56,898 lb</b>

Based on 2438 mm (96") carriage, Fusion coupler and Fusion pallet fork.

Static tipping loads and operating weight are based on the following loader configuration: L3 Michelin XHA tires, air conditioning, ride control, power train guard, full fluids, fuel tank, coolant, lubricants, and operator. Static tipping loads conform to the international standard as defined in ISO\* 14397-1 (Sept2007).

Specifications and ratings conform to the following standards: ISO 14397-1, SAE\*\* J1197, SAE J732, CEN\*\*\* EN 474-3.

†Rated load is determined by considering % of machine stability, hydraulic lift capacity, and hydraulic tilt capacity. Please contact your dealer to properly select the machine configuration for handling target payloads in your specific machine application.

Machine and work tool availability varies by region. Contact your local Cat dealer for product availability.

The rated operating load for a loader equipped with a pallet fork is determined by:

- SAE J1197: 50% of full turn static tipping load or hydraulic limit.
- CEN EN 474-3: 60% of full turn static tipping load on rough terrain or hydraulic limit.
- CEN EN 474-3: 80% of full turn static tipping load on firm and level ground or hydraulic limit.

\*ISO — International Organization for Standardization

\*\*SAE — Society of Automotive Engineers

\*\*\*CEN — European Committee for Standardization

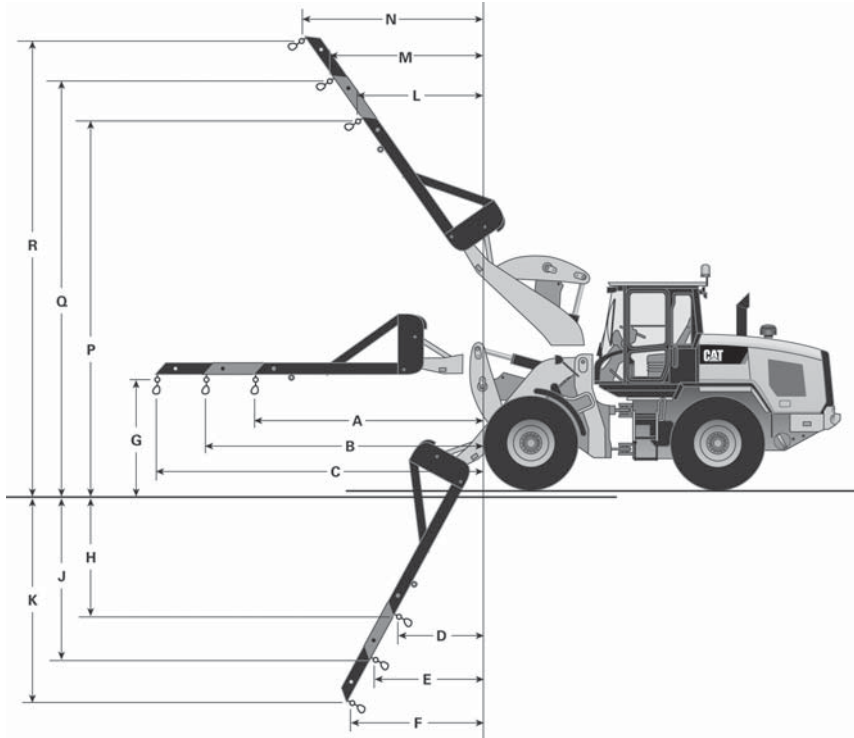

Dimensions listed are for a machine configured with Fusion work tool, standard counterweight, additional guarding, 80 kg (176 lb) operator, and Michelin 20.5 R25 (L-3) XHA2 tires.

MODEL	926M* Standard		926M* High Lift	
Operating load (retracted) @ full articulation	1928 kg	<b>4250 lb</b>	1631 kg	<b>3595 lb</b>
<b>A</b> Reach horizontal (retracted)	3727 mm	<b>12'3"</b>	4250 mm	<b>13'11"</b>
Operating load (mid-position) @ full articulation	1635 kg	<b>3605 lb</b>	1406 kg	<b>3099 lb</b>
<b>B</b> Reach horizontal (mid-position)	4527 mm	<b>14'10"</b>	5050 mm	<b>16'7"</b>
Operating load (extended) @ full articulation	1420 kg	<b>3130 lb</b>	1235 kg	<b>2723 lb</b>
<b>C</b> Reach horizontal (extended)	5327 mm	<b>17'6"</b>	5850 mm	<b>19'2"</b>
<b>D</b> Reach full down (retracted)	1045 mm	<b>3'5"</b>	1689 mm	<b>5'6"</b>
<b>E</b> Reach full down (mid-position)	1276 mm	<b>4'2"</b>	1922 mm	<b>6'4"</b>
<b>F</b> Reach full down (extended)	1507 mm	<b>4'11"</b>	2154 mm	<b>7'1"</b>
<b>G</b> Clearance horizontal	1854 mm	<b>6'1"</b>	1854 mm	<b>6'1"</b>
<b>H</b> Clearance full down (retracted)	2310 mm	<b>7'7"</b>	2343 mm	<b>7'8"</b>
<b>J</b> Clearance full down (mid-position)	3076 mm	<b>10'1"</b>	3109 mm	<b>10'2"</b>
<b>K</b> Clearance full down (extended)	3842 mm	<b>12'7"</b>	3874 mm	<b>12'9"</b>
<b>L</b> Reach at maximum height (retracted)	2333 mm	<b>7'8"</b>	2646 mm	<b>8'8"</b>
<b>M</b> Reach at maximum height (mid-position)	2919 mm	<b>9'7"</b>	3258 mm	<b>10'8"</b>
<b>N</b> Reach at maximum height (extended)	3505 mm	<b>11'6"</b>	3869 mm	<b>12'8"</b>
<b>P</b> Clearance at maximum height (retracted)	5568 mm	<b>18'3"</b>	5963 mm	<b>19'7"</b>
<b>Q</b> Clearance at maximum height (mid-position)	6112 mm	<b>20'1"</b>	6479 mm	<b>21'3"</b>
<b>R</b> Clearance at maximum height (extended)	6657 mm	<b>21'10"</b>	6995 mm	<b>22'11"</b>
Tires	<b>20.5 R25 (L-3) XHA2</b>		<b>20.5 R25 (L-3) XHA2</b>	

\*Meets Tier 4 Final/Stage IV/Japan 2014 (Tier 4 Final) emission standards.

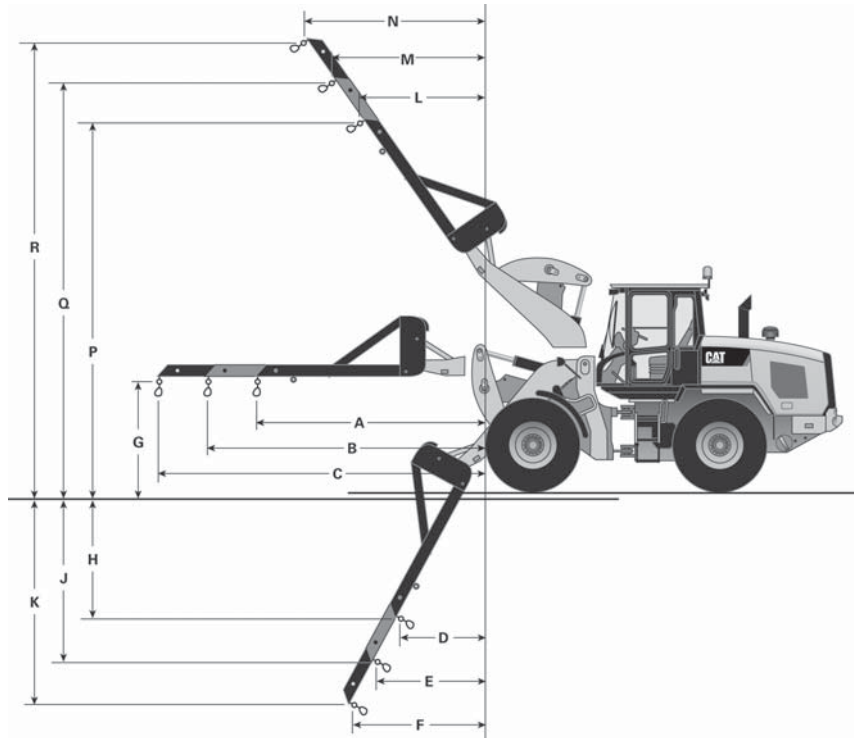

Dimensions listed are for a machine configured with Fusion work tool, heavy counterweight, additional guarding, 80 kg (176 lb) operator, and Michelin 20.5 R25 (L-3) XHA2 tires.

MODEL	930M*		930M*	
	Standard		High Lift	
Operating load (retracted) @ full articulation	2182 kg	<b>4811 lb</b>	1785 kg	<b>3935 lb</b>
<b>A</b> Reach horizontal (retracted)	3727 mm	<b>12'3"</b>	4380 mm	<b>14'4"</b>
Operating load (mid-position) @ full articulation	1851 kg	<b>4081 lb</b>	1544 kg	<b>3404 lb</b>
<b>B</b> Reach horizontal (mid-position)	4527 mm	<b>14'10"</b>	5180 mm	<b>17'0"</b>
Operating load (extended) @ full articulation	1607 kg	<b>3543 lb</b>	1360 kg	<b>2999 lb</b>
<b>C</b> Reach horizontal (extended)	5327 mm	<b>17'6"</b>	5980 mm	<b>19'7"</b>
<b>D</b> Reach full down (retracted)	1045 mm	<b>3'5"</b>	1908 mm	<b>6'3"</b>
<b>E</b> Reach full down (mid-position)	1276 mm	<b>4'2"</b>	2160 mm	<b>7'1"</b>
<b>F</b> Reach full down (extended)	1507 mm	<b>4'11"</b>	2412 mm	<b>7'11"</b>
<b>G</b> Clearance horizontal	1854 mm	<b>6'1"</b>	1854 mm	<b>6'1"</b>
<b>H</b> Clearance full down (retracted)	2310 mm	<b>7'7"</b>	2327 mm	<b>7'8"</b>
<b>J</b> Clearance full down (mid-position)	3076 mm	<b>10'1"</b>	3087 mm	<b>10'2"</b>
<b>K</b> Clearance full down (extended)	3842 mm	<b>12'7"</b>	3846 mm	<b>12'7"</b>
<b>L</b> Reach at maximum height (retracted)	2333 mm	<b>7'8"</b>	2689 mm	<b>8'10"</b>
<b>M</b> Reach at maximum height (mid-position)	2919 mm	<b>9'7"</b>	3287 mm	<b>10'9"</b>
<b>N</b> Reach at maximum height (extended)	3505 mm	<b>11'6"</b>	3885 mm	<b>12'9"</b>
<b>P</b> Clearance at maximum height (retracted)	5568 mm	<b>18'3"</b>	6116 mm	<b>20'1"</b>
<b>Q</b> Clearance at maximum height (mid-position)	6112 mm	<b>20'1"</b>	6647 mm	<b>21'10"</b>
<b>R</b> Clearance at maximum height (extended)	6657 mm	<b>21'10"</b>	7178 mm	<b>23'7"</b>
Tires	<b>20.5 R25 (L-3) XHA2</b>		<b>20.5 R25 (L-3) XHA2</b>	

\*Meets Tier 4 Final/Stage IV/Japan 2014 (Tier 4 Final) emission standards.

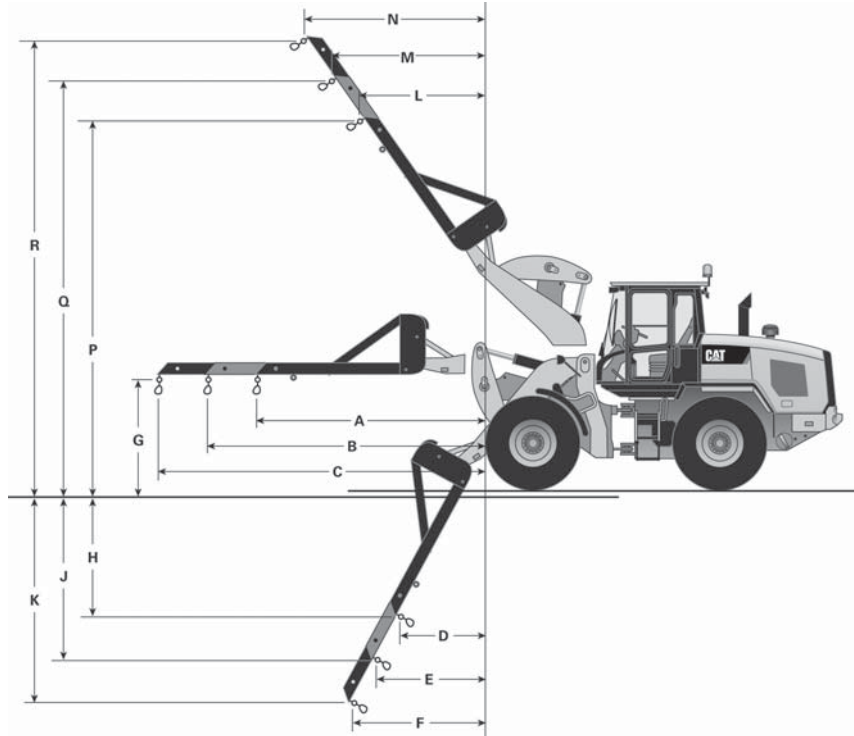

Dimensions listed are for a machine configured with Fusion work tool, heavy counterweight, additional guarding, 80 kg (176 lb) operator, and Michelin 20.5 R25 (L-3) XHA2 tires.

MODEL	938M*		938M*	
	Standard		High Lift	
Operating load (retracted) @ full articulation	2637 kg	<b>5814 lb</b>	2092 kg	<b>4612 lb</b>
<b>A</b> Reach horizontal (retracted)	3775 mm	<b>12'5"</b>	4383 mm	<b>14'5"</b>
Operating load (mid-position) @ full articulation	2241 kg	<b>4940 lb</b>	1810 kg	<b>3990 lb</b>
<b>B</b> Reach horizontal (mid-position)	4575 mm	<b>15'0"</b>	5183 mm	<b>17'0"</b>
Operating load (extended) @ full articulation	1948 kg	<b>4294 lb</b>	1594 kg	<b>3515 lb</b>
<b>C</b> Reach horizontal (extended)	2512 mm	<b>8'3"</b>	5983 mm	<b>19'8"</b>
<b>D</b> Reach full down (retracted)	1089 mm	<b>3'6"</b>	1873 mm	<b>6'2"</b>
<b>E</b> Reach full down (mid-position)	1324 mm	<b>4'4"</b>	2121 mm	<b>7'0"</b>
<b>F</b> Reach full down (extended)	1559 mm	<b>5'1"</b>	2369 mm	<b>7'9"</b>
<b>G</b> Clearance horizontal	1890 mm	<b>6'2"</b>	1890 mm	<b>6'2"</b>
<b>H</b> Clearance full down (retracted)	2316 mm	<b>7'7"</b>	2340 mm	<b>7'8"</b>
<b>J</b> Clearance full down (mid-position)	3081 mm	<b>10'1"</b>	3100 mm	<b>10'2"</b>
<b>K</b> Clearance full down (extended)	3846 mm	<b>12'7"</b>	3861 mm	<b>12'8"</b>
<b>L</b> Reach at maximum height (retracted)	2361 mm	<b>7'9"</b>	2679 mm	<b>8'9"</b>
<b>M</b> Reach at maximum height (mid-position)	2943 mm	<b>9'8"</b>	3277 mm	<b>10'9"</b>
<b>N</b> Reach at maximum height (extended)	3525 mm	<b>11'7"</b>	3874 mm	<b>12'9"</b>
<b>P</b> Clearance at maximum height (retracted)	5655 mm	<b>18'7"</b>	6174 mm	<b>20'3"</b>
<b>Q</b> Clearance at maximum height (mid-position)	6204 mm	<b>20'4"</b>	6706 mm	<b>22'0"</b>
<b>R</b> Clearance at maximum height (extended)	6754 mm	<b>22'2"</b>	7238 mm	<b>23'9"</b>
Tires	<b>20.5 R25 (L-3) XHA2</b>		<b>20.5 R25 (L-3) XHA2</b>	

\*Meets Tier 4 Final/Stage IV/Japan 2014 (Tier 4 Final) emission standards.

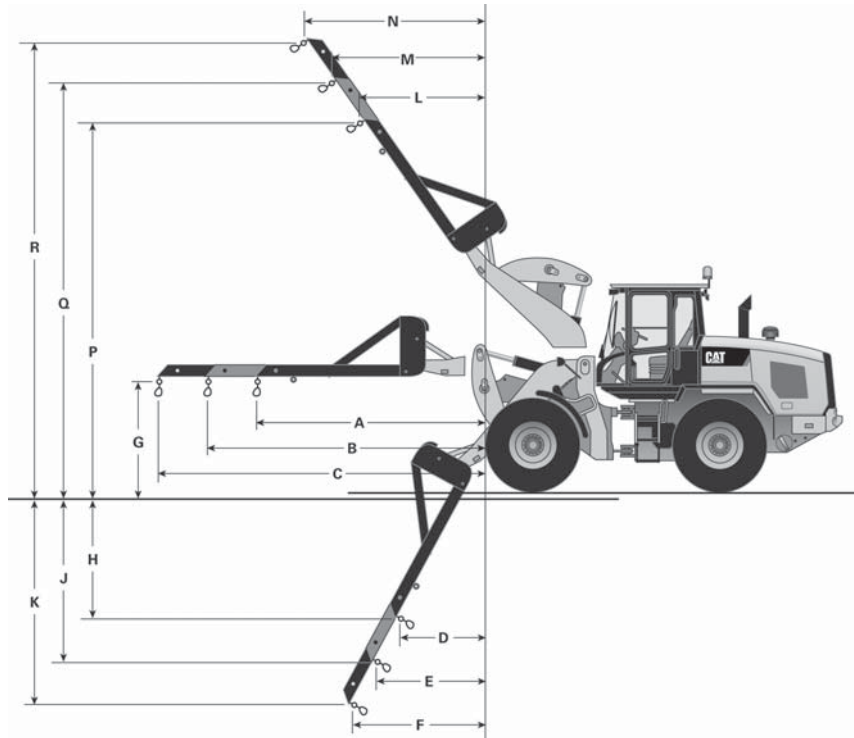

**MODEL**

**924K  
Standard**

A Operating load (retracted) @ full articulation	1850 kg	4078 lb
B Reach horizontal (retracted)	3680 mm	12'0"
C Operating load (mid-position) @ full articulation	1566 kg	3453 lb
D Reach horizontal (mid-position)	4480 mm	14'8"
E Operating load (extended) @ full articulation	1358 kg	2994 lb
F Reach horizontal (extended)	5280 mm	17'3"
G Clearance horizontal	1823 mm	5'11"
H Reach full down (retracted)	373 mm	1'2"
J Reach full down (mid-position)	411 mm	1'4"
K Reach full down (extended)	448 mm	1'5"
L Clearance full down (retracted)	2381 mm	7'9"
M Clearance full down (mid-position)	3180 mm	10'5"
N Clearance full down (extended)	3979 mm	13'0"
P Reach at maximum height (retracted)	2551 mm	8'4"
Q Reach at maximum height (mid-position)	3223 mm	10'6"
R Reach at maximum height (extended)	3896 mm	12'9"
S Clearance at maximum height (retracted)	5134 mm	16'10"
T Clearance at maximum height (mid-position)	5567 mm	18'3"
U Clearance at maximum height (extended)	6000 mm	19'8"
Tires	<b>Michelin 20.5 R25 (L-3) XHA2</b>	

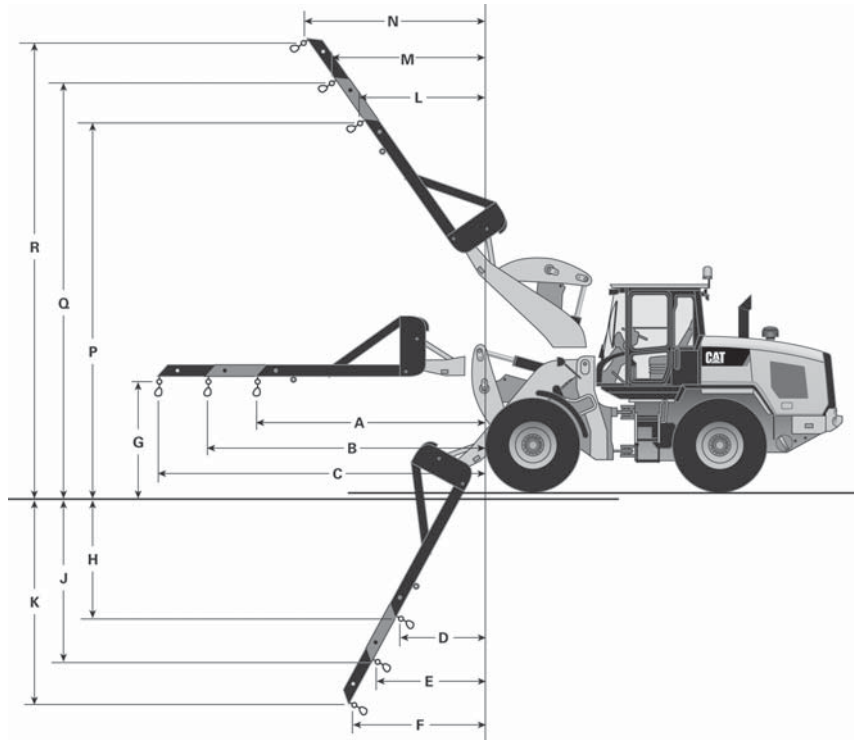

MODEL	930K		938K	
	Standard		Standard	
A Rated operating load (retracted) @ full articulation	2061 kg	<b>4544 lb</b>	2501 kg	<b>5514 lb</b>
B Reach horizontal (retracted)	3727 mm	<b>12'2"</b>	3775 mm	<b>12'4"</b>
C Rated operating load (mid-position) @ full articulation	1748 kg	<b>3854 lb</b>	2125 kg	<b>4684 lb</b>
D Reach horizontal (mid-position)	4527 mm	<b>14'10"</b>	4575 mm	<b>15'0"</b>
E Rated operating load (extended) @ full articulation	1518 kg	<b>3346 lb</b>	1847 kg	<b>4072 lb</b>
F Reach horizontal (extended)	5327 mm	<b>17'5"</b>	5376 mm	<b>17'7"</b>
G Clearance horizontal	1854 mm	<b>6'0"</b>	1890 mm	<b>6'2"</b>
H Reach full down (retracted)	1045 mm	<b>3'5"</b>	1089 mm	<b>3'6"</b>
J Reach full down (mid-position)	1276 mm	<b>4'2"</b>	1324 mm	<b>4'4"</b>
K Reach full down (extended)	1507 mm	<b>4'11"</b>	1559 mm	<b>5'1"</b>
L Clearance full down (retracted)	2310 mm	<b>7'6"</b>	2316 mm	<b>7'7"</b>
M Clearance full down (mid-position)	3076 mm	<b>10'1"</b>	3081 mm	<b>10'1"</b>
N Clearance full down (extended)	3842 mm	<b>12'7"</b>	3846 mm	<b>12'7"</b>
P Reach at maximum height (retracted)	2333 mm	<b>7'7"</b>	2362 mm	<b>7'8"</b>
Q Reach at maximum height (mid-position)	2919 mm	<b>9'6"</b>	2943 mm	<b>9'7"</b>
R Reach at maximum height (extended)	3505 mm	<b>11'6"</b>	3525 mm	<b>11'6"</b>
S Clearance at maximum height (retracted)	5568 mm	<b>18'3"</b>	5655 mm	<b>18'6"</b>
T Clearance at maximum height (mid-position)	6112 mm	<b>20'0"</b>	6204 mm	<b>20'4"</b>
U Clearance at maximum height (extended)	6657 mm	<b>21'10"</b>	6754 mm	<b>22'1"</b>
Tires	<b>Michelin 20.5 R25 (L-3) XHA2</b>		<b>Michelin 20.5 R25 (L-3) XHA2</b>	

**SPECIFICATION DEFINITIONS FOR  
FRONT END LOADERS**

Cat wheel and track loader specifications conform to Society of Automotive Engineers (SAE) definitions as expressed in standards J732 (JUN92), as follows:

**Description of Specification Machine**

On wheel loaders the tire inflation pressure at which specifications are taken must be described in addition to the current written basic machine description. On track loaders the type of grouser must be specified.

**Hydraulic Cycle Times**

- a. "Raise Time" — Time in seconds required to raise the bucket from level position on the ground.
- b. "Lower Time" — Time in seconds required to lower the empty bucket from the full height to a level position on the ground.
- c. "Dump Time" — Time in seconds required to move the bucket at maximum height from the maximum rollback position to full dump position while dumping the SAE loose material operating load.

**Breakout Force**

"Breakout force," pounds (and kilonewtons or kilograms) — the maximum sustained vertical upward force exerted 100 mm (4") behind the tip of the bucket cutting edge and achieved through the ability to lift and/or rollback about the specified pivot point under the following conditions:

- a. Loader on a hard level surface with transmission in neutral.
- b. All brakes released.
- c. Unit at standard operating weight — rear of loader not tied down.
- d. Bottom of cutting edge parallel to and not more than 20 mm (0.75") above or below the ground line.

- e. When bucket circuit is used the pivot point must be specified as the bucket hinge pin, and the unit blocked under the bucket hinge pin pivot point in order to minimize linkage movement.
- f. When the lift circuit is used, the pivot point must be specified as the lift arm hinge pin. Wheel loaders shall have front axle blocked to eliminate change in position of pivot pins due to tire deflection.
- g. If both circuits are used simultaneously, the dominating pivot point listed in (e) or (f) must be specified.
- h. If the circuit used causes the rear of the vehicle to leave the ground, then the vertical force value required to raise the rear of the vehicle is the breakout force.
- i. For irregular shaped buckets, the tip of the bucket cutting edge referred to above shall mean the farther forward point of the cutting edge.

The following are illustrations used (according to provisions of SAE J732 JUN92) to measure Cat Loader breakout forces.

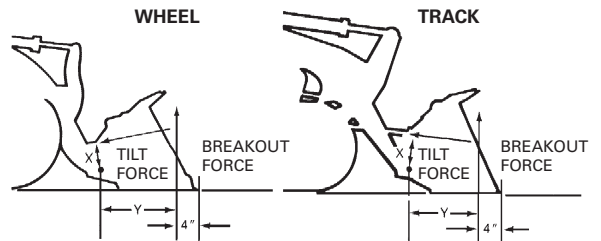

- a. Breakout force resulting from rack back:  
 $(\text{Tilt Force}) \times (\text{Dist. "X"}) = (\text{"Y" Dist.}) \times (\text{Breakout Force})$

$$\frac{(\text{Tilt Force}) \times (\text{Dist. "X"})}{\text{"Y" Dist.}} = \text{Breakout Force}$$

## b. Breakout force resulting from bucket lift:

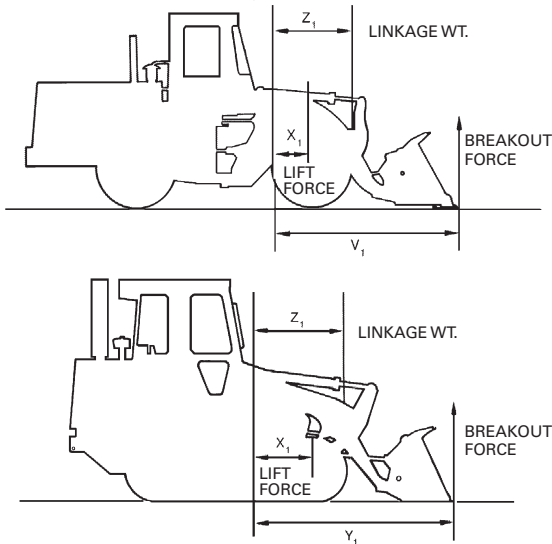

$$\begin{aligned} (\text{Lift Force}) \times (\text{Dist. "X}_1\text{")} &= (\text{"Y}_1\text{ Dist.}) \times (\text{Breakout Force}) \\ &+ (\text{Linkage Wt.}) \times (\text{Dist. "Z}_1\text{")} \\ &+ (\text{Breakout Force}) \times (\text{Linkage Mechanical Advantage "V}_1\text{")} \\ &\text{or} \\ (\text{Lift Force}) \times (\text{Dist. "X}_1\text{")} - &(\text{Linkage Wt.}) \times (\text{Dist. "Z}_1\text{")} \\ \text{Breakout Force} = &\frac{(\text{Dist. "Y}_1\text{") + (\text{Dist. "V}_1\text{") \times}}{(\text{Linkage Mech. Advantage})} \end{aligned}$$

**Static Tipping Load**

The minimum weight at center of gravity of "SAE Rated" load in bucket which will rotate rear of machine to a point where, on track loaders, front rollers are clear of the track and on wheel loaders, rear wheels are clear of the ground under the following conditions:

- Loader on hard level surface and stationary.
- Unit at standard operating weight.
- Bucket at maximum rollback position.
- Load at maximum forward position during raising cycle.
- For articulated wheel loaders, the test will be run both with frame straight (straight static tipping load) and fully turned to a specific angle (full turn static tipping load).
- Unit with standard equipment as described in specifications unless otherwise noted under the heading.

**Operating Load**

In order to comply with SAE standard J818 MAY87, the operating load of Wheel Loaders should not exceed 50% of the full turn Static Tipping load of the machine when equipped with attachments needed for the job. (For track loaders, operating load should not exceed 35% of the Static Tipping load rating.) See "Performance Data" of each machine in this handbook for increases to static tipping load by adding cab, counterweights, ripper-scarifier, etc.

The SAE operating load is not an indication of a wheel loader's rated payload. It takes into consideration only hydraulic lift and tipping capacity. There is no regard to structural and/or component lives, and for wheel loaders is measured on hard, moderately smooth and level operating surfaces.

**Carry Position**

SAE defines carry positions as: "The vertical distance from the ground to the center line of the bucket hinge pin, with the angle of approach at 15°." The sketch below illustrates this definition:

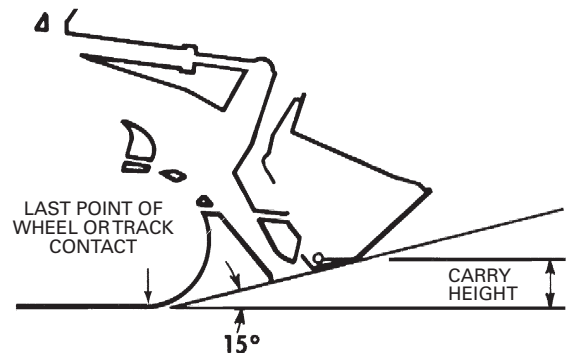
**Loader Clearance Circle**

SAE J732 JUN92 states that "minimum turning radius (over tire)" and "loader clearance circle" should be given for wheel loaders. Both are given on Cat specification sheets, including loader clearance circles for all available buckets for each machine.

**Digging Depth**

J732 JUN92 specifies digging depth as "the vertical distance in mm (inches) from the ground line to the bottom of the bucket cutting edge at the lowest position with the bucket cutting edge horizontal."



### SAE BUCKET RATING

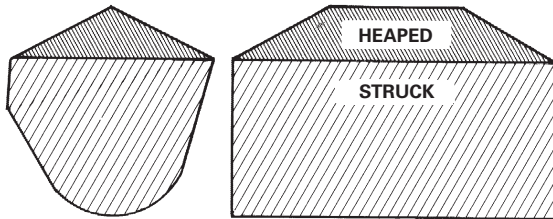

### SAE Bucket Capacities

*Struck capacity* is that volume contained in a bucket after a load is leveled by drawing a straight edge resting on the cutting edge and the back of the bucket.

*Heaped capacity* is a struck capacity plus that additional material that would heap on the struck load at a 2:1 angle of repose with the struck line parallel to the ground.

SAE J742 (FEB85) specifies that the addition of any auxiliary spill guard to protect against spillage which might injure the operator will not be included in bucket capacity ratings. Buckets with irregular shaped cutting edges (vee edge) the strike plane should be drawn at one-third the distance of the protruding portion of the cutting edge. Cat rock buckets are built with integral see-through rock guards. Cat light material buckets come standard with bolt-on edges. These features which add to actual bucket capacity are included in published ratings.

### Dump Height

SAE J732 JUN92 specifies that dump height is the vertical distance from the ground to the lowest point of the cutting edge with the bucket hinge pin at maximum height and the bucket at a 45° dump angle. Dump angle is the angle in degrees that the longest flat section of the inside bottom of the bucket will rotate below horizontal.

## SELECTING A MACHINE

### Steps in selecting the proper size loader:

1. Determine production required or desired.
2. Determine loader cycle time and cycles per hour. A machine size must be assumed to select a basic cycle time.

3. Determine required payload per cycle in loose cubic yards and pounds (meters and kilograms).
4. Determine bucket size needed.
5. Make machine selection using bucket size and payload as criteria to meet production requirements.
6. Compare the loader cycle time used in calculations to the cycle time of the machine selected. If there is a difference, rework the process beginning at step 2.

### 1. Production Required

The production required of a wheel or track loader should be slightly greater than the production capability of the other critical units in the earth or material moving system. For example, if a hopper can handle 300 tons per hour, a loader capable of slightly more than 300 tons should be used. Required production should be carefully calculated so the proper machine and bucket selections are made.

### 2. Loader Cycle Times

When hauling loose granular material on a hard smooth operating surface, a .45-.55 minute basic cycle time is considered reasonable for Cat articulated loaders with a competent operator. This includes load, dump, four reversals of direction, full cycle of hydraulics and minimum travel.

Material type, pile height, and other factors may improve or reduce production, and should be added to or subtracted from the basic cycle time when applicable.

When hauls are involved, obtain the haul and return portion of the cycle from the estimated travel chart (this section). Add the haul and return times to the estimated basic cycle time to obtain total cycle time.

### CYCLE TIME FACTORS

A basic cycle time (Load, Dump, Maneuver) of .45-.55 minutes is average for an articulated loader [the basic cycle for large loaders, 3 m<sup>3</sup> (4 yd<sup>3</sup>) and up, can be slightly longer], but variations can be anticipated in the field. The following values for many variable elements are based on normal operations. Adding or subtracting any of the variable times will give the total basic cycle time.

Minutes added (+)  
 or Subtracted (-)  
 From Basic Cycle

<i>Machine</i>	
— Material handler . . . . .	-.05
<i>Materials</i>	
— Mixed . . . . .	+.02
— Up to 3 mm (1/8 in) . . . . .	+.02
— 3 mm (1/8 in) to 20 mm (3/4 in) . . . . .	-.02
— 20 mm (3/4 in) to 150 mm (6 in) . . . . .	.00
— 150 mm (6 in) and over . . . . .	+.03 and Up
— Bank or broken . . . . .	+.04 and Up
<i>Pile</i>	
— Conveyor or Dozer piled 3 m (10 ft) and up . . . . .	.00
— Conveyor or Dozer piled 3 m (10 ft) or less . . . . .	+.01
— Dumped by truck . . . . .	+.02
<i>Miscellaneous</i>	
— Common ownership of trucks and loaders . . . . .	Up to -.04
— Independently owned trucks . . . . .	Up to +.04
— Constant operation . . . . .	Up to -.04
— Inconsistent operation . . . . .	Up to +.04
— Small target . . . . .	Up to +.04
— Fragile target . . . . .	Up to +.05

Using actual job conditions and the above factors, total cycle time can be estimated. Convert total cycle time to cycles per hour.

$$\text{Cycles per hour at 100\% Efficiency} = \frac{60 \text{ min}}{\text{Total Cycle Time in Minutes}}$$

Job efficiency is an important factor in machine selection. Efficiency is the actual number of minutes worked during an hour. Job efficiency accounts for bathroom breaks and other work interruptions.

$$\begin{array}{l} \text{Cycles per hour at 50 minutes per hour (83\% efficiency)} \\ \text{Cycles per hour at 100\% efficiency} \end{array} = \frac{50 \text{ min} \times \text{actual work time}}{60 \text{ min hour}}$$

**TRUCK LOADING**

Average loader cycle times

910K-962H . . . . .	0.45-0.50 min
966H-980H . . . . .	0.50-0.55 min
986H-990K . . . . .	0.55-0.60 min
992K-994K . . . . .	0.60-0.70 min

**3. Required Payload Per Cycle**

Required payload per cycle is determined by dividing required hourly production by the number of cycles per hour.

**4. Bucket Selection**

After required payload per cycle has been calculated, the payload should be divided by the loose cubic yard (meter) material weight to determine number of loose cubic yards (meters) required per cycle.

The bulk of material handled does not weigh 1800 kg/m<sup>3</sup> (3000 lb/yd<sup>3</sup>), so a reasonable knowledge of material weight is necessary for accurate production estimates. The Tables Section has average weight for certain materials when actual weights are not known.

The percentage of rated capacity a bucket carries in various materials is estimated below. The bucket size required to handle the required volume per cycle is found with the aid of the percentage of rated bucket capacity called "Bucket Fill Factor."

The bucket size needed is determined by dividing loose cubic meters (or yards) required per cycle by the bucket fill factor.

$$\text{Bucket size} = \frac{\text{Volume Required/Cycle}}{\text{Bucket Fill Factor}}$$

**BUCKET FILL FACTORS**

The following indicates the approximate amounts of material as a percent of rated bucket capacity which will actually be delivered per bucket per cycle. This is known as "Bucket Fill Factor."

Loose Material	Fill factor
Mixed moist aggregates . . . . .	95-100%
Uniform aggregates up to 3 mm (1/8 in) . . . . .	95-100
3 mm (1/8 in) to 9 mm (3/8 in) . . . . .	90-95
12 mm (1/2 in) to 20 mm (3/4 in) . . . . .	85-90
24 mm (1.0 in) and over . . . . .	85-90

# Wheel Loaders Integrated Toolcarriers

## Machine Selection

- Bucket Fill Factors
- Example Problem

### Blasted Rock

Well blasted . . . . .	80-95%
Average . . . . .	75-90
Poor . . . . .	60-75

### Other

Rock dirt mixtures . . . . .	100-120%
Moist loam . . . . .	100-110
Soil, boulders, roots . . . . .	80-100
Cemented materials . . . . .	85-95

**NOTE:** Fill factors on wheel loaders are affected by bucket penetration, breakout force, rack back angle, bucket profile and ground engaging tools such as bucket teeth or bolt-on replaceable cutting edges.

### Example:

12 mm (1/2 in) material and 3 m<sup>3</sup> (4 yd<sup>3</sup>) bucket.  
 0.90 × 3 m<sup>3</sup> = 2.75 Loose m<sup>3</sup> delivered per cycle.  
 0.90 × 4 yd<sup>3</sup> = 3.6 Loose yd<sup>3</sup> delivered per cycle.

**NOTE:** Check the static tipping load on the specific machine to determine if bucket load is in fact a safe operating load.

### Bucket Selection

$$\text{Tons Required/Cycle} = \frac{\text{Tons Required/Hour}}{\text{Cycles/Hour}}$$

$$\text{Kg (Pounds) Required/Cycle} = \frac{\text{Tons Required/Cycle} \times 907 \text{ kg (2000 lb)}}{\text{Cycles/Hour}}$$

$$\text{Volume Required/Cycle} = \frac{\text{kg (Pounds) Cycle}}{\text{Material Weight kg/m}^3 \text{ (lb/yd}^3)}$$

Always select a machine with a greater capacity than the calculated required operating capacity. For most applications, payload above recommended and excessive counterweight can hinder machine performance and reduce dynamic stability and machine life.

For optimum performance in fast cycling situations such as truck loading, operating loads should not exceed the recommended capacity. To provide extra stability, calcium chloride (CaCl<sub>2</sub>) ballast may be desired when operating at recommended operating load, see SAE Loader rating pages in this section. For specific stability data and optional tire sizes, see the "Performance Data" pages in this section.

When selecting special application buckets, such as multi-purpose and side dump the additional bucket weight must be deducted from recommended capacity.

Specific circumstances may involve other conditions which would also affect loader capacity. Because of the greatly varied applications and conditions, your Cat dealer should be contacted for guidance.

### Example problem:

#### JOB CONDITIONS

Application	Truck loading
Production Required	450 metric ton (496 Tons) per hour
Material	9 mm (3/8") gravel in 6 m (20 ft) high stockpile
Density	1660 kg/m <sup>3</sup> (2800 lb/yd <sup>3</sup> )

Trucks are 6-9 m<sup>3</sup> (8-12 yd<sup>3</sup>) capacity and are owned by three contractors. Loading is constant. Hard level surface for loader maneuvering.

1. **PRODUCTION REQUIRED:** Given
2. **CYCLE TIME:** Assume loader size between 910K and 962H for initial choice of basic cycle.

(Refer to Cycle Time Factors in this section)

Independent trucks	.04 min
Basic Cycle	.50 min
Material	-.02 min
Independent trucks	+.04 min
Constant operation	-.02 min
Total Cycle	.50 min

**NOTE:** Load and carry times not required in total cycle.

$$\begin{aligned} \text{Cycles/hr at 83\% efficiency} &= \frac{120 \text{ cycles/hr} \times \frac{50 \text{ min actual work time}}{60 \text{ min per hr}}}{100} \\ &= 100 \text{ cycles/hr} \end{aligned}$$

3. **VOLUME REQUIRED PER CYCLE**

(Density in tons)

Density in this example was given. When not given, refer to Tables Section to obtain an estimated density for the material being handled.

$$\text{Metric: } \frac{1660 \text{ kg/m}^3}{1000 \text{ kg/ton}} = 1.66 \text{ ton/m}^3$$

$$\text{English: } \frac{2800 \text{ lb/yd}^3}{2000 \text{ lb/ton}} = 1.4 \text{ tons/yd}^3$$

**Production Rate Required**

$$\text{Metric: } \frac{450 \text{ tons/hr}}{1.66 \text{ tons/m}^3} = 271 \text{ m}^3/\text{hr}$$

$$\text{English: } \frac{496 \text{ tons/hr}}{1.4 \text{ tons/yd}^3} = 354 \text{ yd}^3/\text{hr}$$

**Volume Required per Cycle**

$$\text{Metric: } \frac{271 \text{ m}^3/\text{hr}}{100 \text{ cycles/hr}} = 2.71 \text{ m}^3/\text{cycle}$$

$$\text{English: } \frac{354 \text{ yd}^3/\text{hr}}{100 \text{ cycles/hr}} = 3.54 \text{ yd}^3/\text{cycle}$$

4. **DETERMINE BUCKET SIZE**

**BUCKET FILL FACTOR**

The volume of material required per cycle has been determined. Because of varying material fill factors, buckets do not always carry their rated load, a larger capacity bucket may be needed to carry the volume required. For fill factors, refer to Bucket Fill Factor Chart in this section.

Rated Bucket Capacity Required (Heaped)

$$\frac{2.71 \text{ m}^3/\text{cycle}}{0.95 \text{ fill factor}} = 2.85 \text{ m}^3$$

$$\frac{3.54 \text{ yd}^3/\text{cycle}}{0.95 \text{ fill factor}} = 3.73 \text{ yd}^3$$

A 2.9 m<sup>3</sup> (3.75 yd<sup>3</sup>) bucket would provide the required capacity.

5. **MACHINE SELECTION**

The bucket size required and material density lead to the choice of a 950H with a 2.9 m<sup>3</sup> (3.75 yd<sup>3</sup>) General Purpose Bucket (see bucket selection guide pages which follow.)

Finally, SAE payload criteria must be satisfied as follows:

The required operating capacity must not exceed one-half of the full turn static tipping load of the loader as equipped with a specific bucket.

The required operating capacity of the machine is determined by the volume the machine will carry per load times the density.

$$2.9 \text{ m}^3 \times 1660 \text{ kg/m}^3 = 4814 \text{ kg}$$

$$(3.75 \text{ yd}^3 \times 2800 \text{ lb/yd}^3 = 10,500 \text{ lb})$$

One half of full turn static tipping load for the 950H with a 2.9 m<sup>3</sup> (3.75 yd<sup>3</sup>) General Purpose Bucket is 5410 kg (11,925 lb). SAE criteria is satisfied.



**An Alternative Method of Machine Selection**

Another method of selecting the right Wheel Loader and bucket to meet production requirements is by use of the nomographs on the following pages. The method is quicker and easier than the preceding example because it does not require as many calculations, yet the accuracy is about the same within the normal limits of input data.

Be careful when entering and reading data from the nomographs because some scales increase from bottom to top, while others are the reverse. Do not be overly concerned with the precision as affected by pencil line width or reading to the hundredth of a m<sup>3</sup> (yd<sup>3</sup>). Remember that bucket fill factor, material density and cycle time are at best close estimates.

Example problem:

A Wheel Loader must produce 230 m<sup>3</sup> (300 yd<sup>3</sup>) per hour in a truck loading application. Estimated cycle time is .6 minutes, working 45 minutes per hour. Bucket fill factor is 95% and material density is 1780 kg/m<sup>3</sup> (3000 lb/yd<sup>3</sup>).

Determine bucket size and machine model.

Solution:

At full efficiency, the Wheel Loader will cycle 100 times per hour. Since only an average of 45 minutes are available, only 75 cycles will be completed.

Starting on Scale A at 75 cycles per hour draw a straight line intersecting 230 m<sup>3</sup>/hr (300 yd<sup>3</sup>/hr) on Scale B and extending it on to Scale C giving 3 m<sup>3</sup>/cycle (4 yd<sup>3</sup>/cycle) required payload. Follow solution steps 1-10.

# Wheel Loaders Integrated Toolcarriers

## Production and Machine Selection Nomograph

- To find required bucket payload and bucket size

1. Enter required hourly production on Scale B 230 m<sup>3</sup>/hr (300 yd<sup>3</sup>/hr).
2. Enter cycles per hour on Scale A (60 ÷ .6 = 100 × .75 = 75 cycles/hr).
3. Connect A through B to C. This shows a required payload of 3 m<sup>3</sup> (4 yd<sup>3</sup>) per cycle.
4. Enter estimated bucket fill factor on Scale D (0.95).
5. Connect C through Scale D to E for required bucket size 3 m<sup>3</sup> (4 yd<sup>3</sup>).
6. Transfer cycles per hour Scale A and required payload Scale C to the following page.

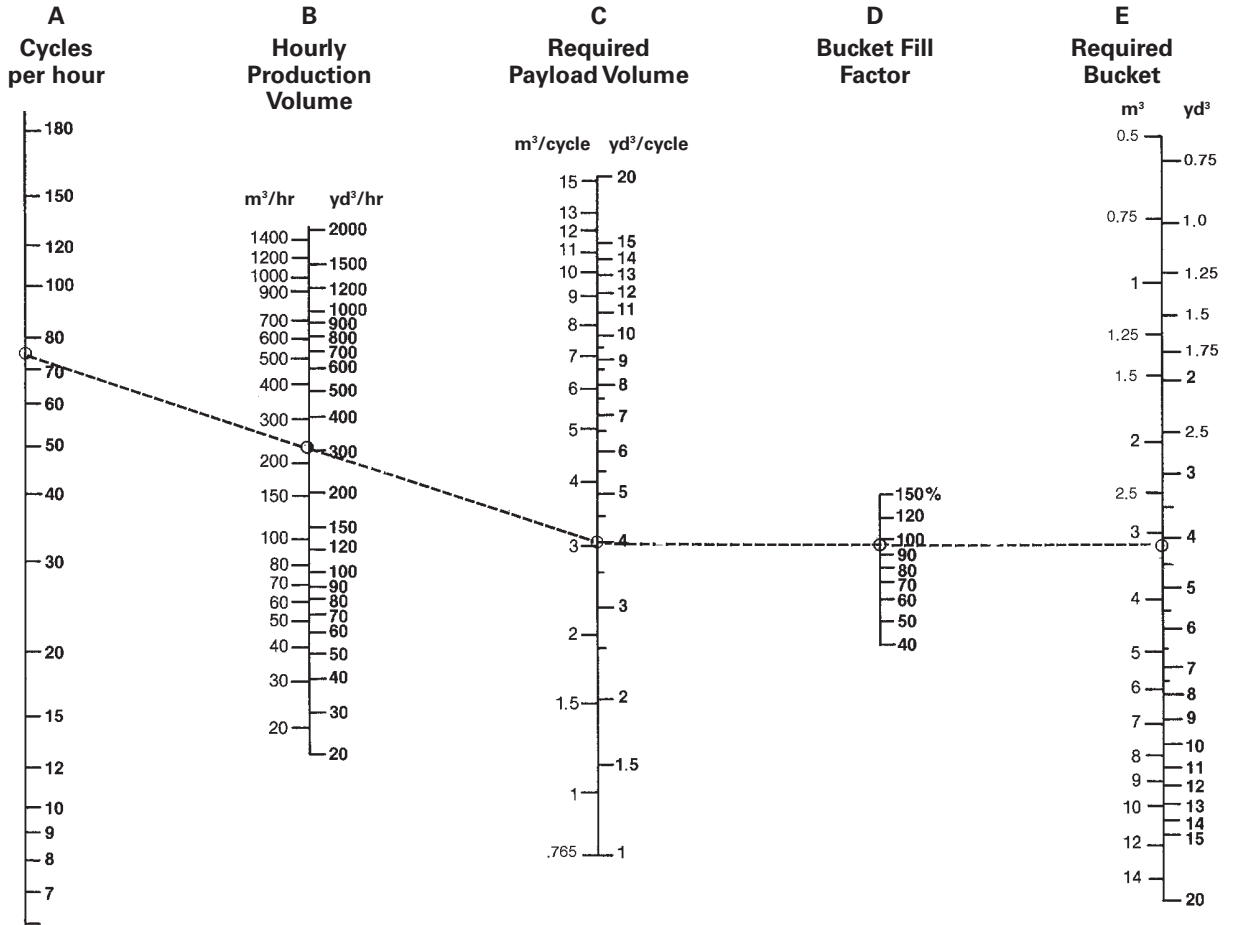

# Production and Machine Selection Nomograph

- To find payload weight and tons per hour

# Wheel Loaders Integrated Toolcarriers

- Enter material density on Scale F 1780 kg/m<sup>3</sup> (3000 lb/yd<sup>3</sup>).
- Connect C through Scale F to Scale G to give payload weight per cycle 5300 kg (11,500 lb).
- Compare Scale G quantity 5300 kg (11,500 lb) with recommended machine working range listed on the following bucket selection pages.

Operating capacity for the 950H with 3.1 m<sup>3</sup> (4 yd<sup>3</sup>) bucket is dependent on material density and bucket capacity (see bucket selection pages that follow).

- For hourly tonnage, draw a straight line from Scale G through Scale A to Scale I metric tons (450 U.S. tons).

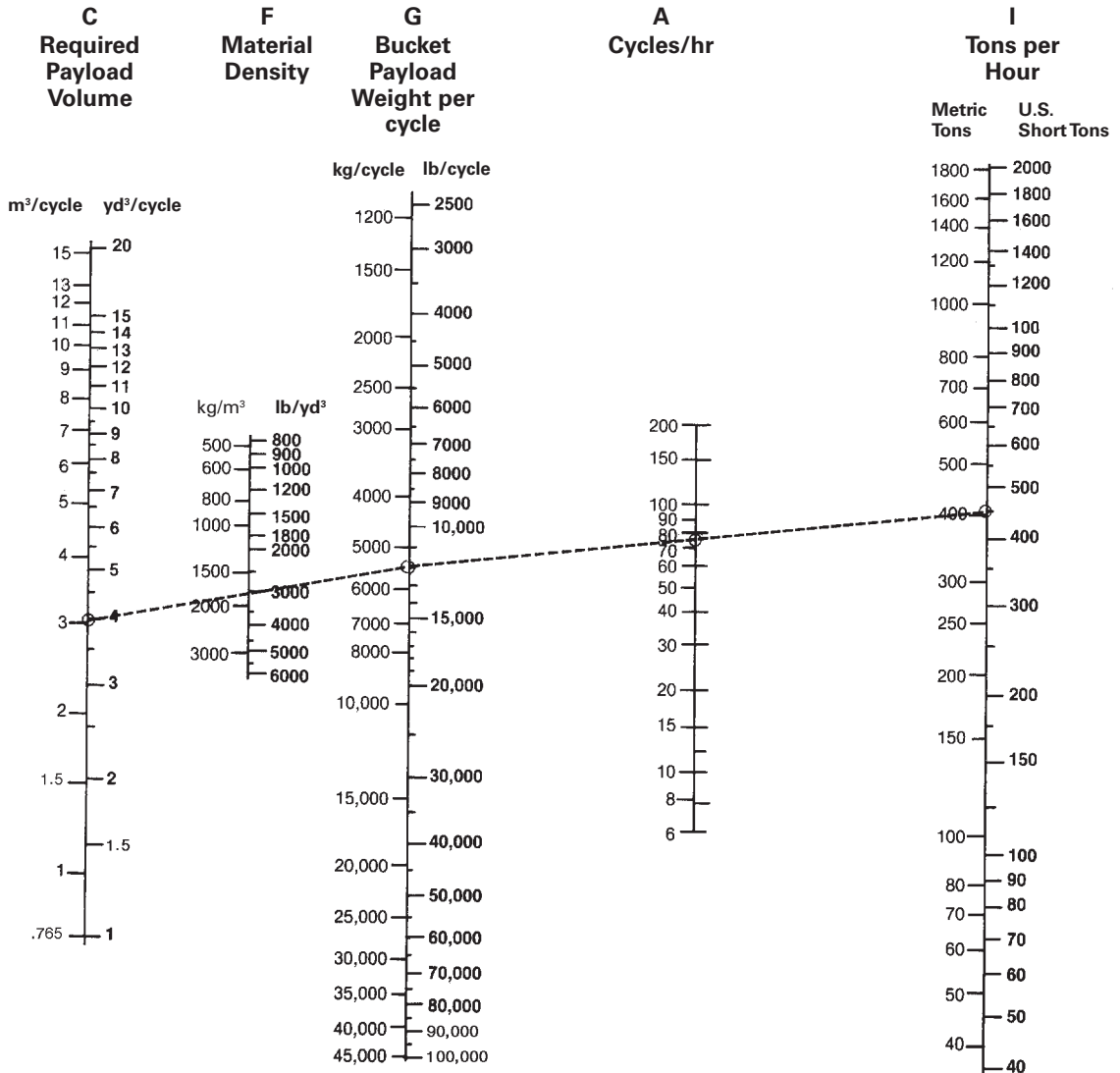

**MACHINE/ATTACHMENT SELECTION**

The Integrated Toolcarrier’s versatility and the wide range of attachments makes the “single machine fleet” concept highly attractive to an increasing number of users.

A Job Analysis helps identify applications, work requirements, material handling parameters and the current working method. Thoroughly research each element in the following chart, the gathered information will help select the proper Integrated Toolcarrier System.

**JOB ANALYSIS METHOD**

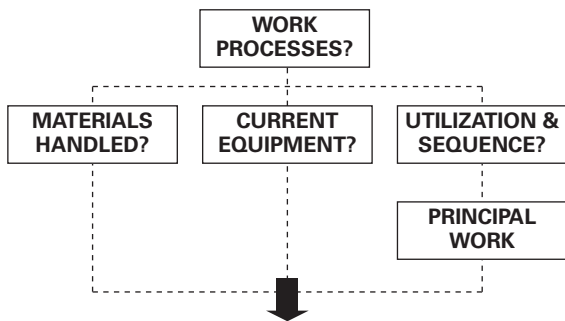

● **APPROPRIATE INTEGRATED TOOLCARRIER MODEL SIZE**

● **NECESSARY ATTACHMENTS**

**Work Processes:**

The first step in the job analysis is to identify all work processes from start to finish. Key questions outlined below will begin to indicate the required attachments and potential Integrated Toolcarrier applications.

- What kinds of work are performed: (e.g., dozing, loading, stacking, digging, sweeping, handling special materials, etc.)
  - ... in site preparation?
  - ... below ground level?
  - ... at ground level?
  - ... above ground level?
  - ... in landscaping?
  - ... in maintenance equipment yard?
  - etc.
- What work is done manually that could be done with an Integrated Toolcarrier?
- What are the work conditions?:
  - ... underfoot?
  - ... grades?
  - ... tight quarters?
  - ... time restraints?
  - ... climate?
  - etc.

**Materials Handled:**

Examining the materials handled will assist in determining necessary attachments. Sizes and weights of material(s) handled will indicate the appropriate Integrated Toolcarrier model by defining lift and reach requirements. Concentrate on the material flow at the job site — the point of origin as well as the final destination for the various materials will undoubtedly have material handling requirements.

- What kinds of materials are handled (e.g. snow, earth, bricks, chemicals, pipe, logs, etc.)
- What form are the materials handled in: bulk? palletized?
- How much does each weigh?
- What are the dimensions of each?
- What are the... movement parameters:
  - ... dozed what distance?
  - ... load and carried what distance?
  - ... lifted how high?
  - ... placed below ground level?
  - ... placed what distance from machine?

**Current Equipment:**

If determining material weight is not possible, much information can be determined from looking at the current equipment fleet. This will suggest required performance capabilities such as lifting capacity.

- Machines currently doing the work (e.g. wheel loaders, lift trucks, sweepers, light capacity cranes, snow plows, etc.)?
- What special (maximum) capabilities does each machine have (production, lift height, load capacity, width/height dimensions, reach, turning radius, travel speed, etc.)?
- To what extent are each machine's maximum capabilities used?
- What are owning/operating costs of each?

**Utilization & Sequence:**

Utilization implies how often the current machines are used and what will be the utilization factors for the Integrated Toolcarrier with each individual attachment. Sequence implies what order these tasks are accomplished in and if two or more machines operate at the same time. This portion of the job analysis should assist in comparing economies of various systems. Other important considerations may be the number of operators needed, storage space, reduced maintenance requirements, etc.

- How often (what percent) is each machine used?
- How often and when does it sit idle?
- How often and when do two or more machines work at the same time?
- Can the operation be changed to permit single machine operation?

**Principal Work:**

Utilization and sequence will indicate the principal work the Integrated Toolcarrier will do, further assisting in attachment and model sizing and selection. The basic machine/tool package should be able to handle the toughest, most frequently performed jobs for the primary application. Secondary tools can have a little more "give and take" in their performance capabilities than the primary tool.

- What work can be accomplished by an Integrated Toolcarrier?
- What work will take up the majority of Integrated Toolcarrier time?
- What work will use the maximum static tipping capabilities of the Integrated Toolcarrier?
- What high cost (owning and operating) and/or low utilization machines can be replaced by an Integrated Toolcarrier?

**Additional Tips for Tool Sizing and Selection**

Tool selection will principally concern hydraulic power requirements and static tipping load considerations. The standard tools offered by Caterpillar can be used on any Integrated Toolcarrier machine with little difficulty. However, tools such as the hydraulic broom, claws, blades and asphalt cutter will require additional consideration before proposing a system to the customer.

**Fork Rating**

ISO 14397-1 states that articulated wheel loaders require the following method for calculating rated load on forks. 50% of the fully articulated tipping load when the lift arms and fork are level, and the load is applied at a point on the longitudinal center line of the machine at half the distance from the most rearward point of the load opening to the tip of the fork, this will be the rated load for that machine in its present configuration. As the machine configuration changes, so does the rated load. EN474-3 states a load center dependent on the value of the load itself. Please refer to that standard for the load center location table. Always refer to the manufacturer of the fork to determine the load rating for the fork tine.



## Bucket Rating

Bucket capacity, SAE J742 FEB85 (nominally heaped)

ISO 14397-1 states that articulated wheel loaders require the following method for calculating rated load, also known as the maximum payload, with buckets. 50% of the fully articulated tipping load when the lift arms are level and bucket fully racked back, and the load is applied at a point on the longitudinal center line of the machine and acting through the bucket volume centroid, this will be the rated load for that machine in its present configuration. As the machine configuration changes, so does the rated load. Please consult your Cat dealer to ensure proper machine configuration selection in conformance to Caterpillar payload policy.

The maximum material density would be determined by dividing the payload by the bucket capacity. If the actual material density exceeds the recommended material density, the process should be repeated to select the properly sized bucket.

A similar procedure would be used with the forks and material handling arm to determine maximum recommended lifting capacity and/or required IT model size.

## **Pallet Fork**

The pallet fork will fulfill many material handling needs. A modified Class 3 fork carriage provides visibility to the tines for precision pallet work. This carriage with non-standard spacing accepts many Class 3 lift truck attachments.

Pallet fork rated operating loads are based on the following:

SAE J1197 FEB91: 50% of the full turn static tipping load or the hydraulic/structural limitations.

CEN 474-3 (European standard): 60% of the full static tipping load on rough terrain or the hydraulic/structural limitations. 80% of the full turn static tipping load on firm, level ground or the structural/hydraulic limitation. Other local, regional or international guidelines may also apply.

If operation is on rough ground these criteria may need modification. In this instance, the size and rating of existing equipment should be considered.

Sizing for pallet work generally consists of answering the following questions.

1. What are the average loaded pallet dimensions?
2. Lift Capacity — what capacity is required to lift and move the average pallet load? The maximum pallet load?
3. Lift Height — can the machine reach the top level of the standard pallet stack? What are the maximum reach, lift and height requirements?
4. Maneuverability — can the machine work around the current aisle configuration? In the stacking aisles? Main aisles? Intersecting aisles? Are 90° turns required in any aisle for material placement?
5. Length — what tine length is required to fit the commonly used pallets? (1219 mm [4'0"] tines are standard length for most palletized material.)
6. Any machine height restrictions?
7. Any special fork configurations required?

Lift capacity, lift height, aisle configuration and tine length are the most important considerations in recommending a pallet handling machine.

Example problem:

The following example applies the job analysis method to a work situation.

**Sewer & Water Contractor**

Sets water lines (152 mm-610 mm [6 in-24 in] iron pipe), sanitary sewer lines (152 mm-457 mm [6 in-18 in] PVC) and storm sewer lines (610 mm-1067 mm [24 in-42 in] concrete pipe) primarily in urban areas ... often-times across or down existing streets.

**Materials**

- Loam/Clay: 1600 kg/m<sup>3</sup> (2700 lb/yd<sup>3</sup>) loose density
- Bedding (Gravel): 1900 kg/m<sup>3</sup> (3200 lb/yd<sup>3</sup>) loose density
- Water Pipe: 610 mm (24 in) push-on joint ductile iron, 6.1 m (20 ft) sections, 1309 kg (2885 lb) 215 kg/m (144.3 lb/ft) × 6.1 m (20 ft).
- Storm Sewer: 1067 mm (42 in), Wall B, concrete pipe, 1.5 m (5 ft) sections, 1556 kg (3430 lb) 1021 kg/m (686 lb/ft × 5 ft).
- Manhole Boxes: 1361 kg (3000 lb)

WHAT INTEGRATED TOOLCARRIER MODEL SHOULD BE RECOMMENDED?

WHICH ATTACHMENTS?

<b>Work Processes</b>	<b>Integrated Toolcarrier Attachment Possibilities</b>
Bundled PVC and individual concrete/iron pipe-loaded/unloaded (yardsite) and strung along trench	Forks/Material Handling Arm
Unload, handle, set manhole boxes	Material Handling Arm
Excess excavated material truck loaded	Bucket
Bedding material handled/ placed	Bucket
Trench backfilled	Bucket/Blade
Trench compaction	Compactor Wheel
Rough and finish grading	Bucket/Blade
Street cleanup	Bucket/Broom
Pavement removal	Rebar Snips/Asphalt Cutter

**Current Equipment**

**Utilization**

- Cat 225. . . . . 90%
- Champ CB607 lift truck, 3175 kg (7000 lb) capacity. . . . . 15%
- Deere 444 with 1.1 m<sup>3</sup> (1.5 yd<sup>3</sup>) G.P. bucket. . . . . 60%
- Rosco D-50 sweeper. . . . . one half hour/day
- Rammax 1361 kg (3000 lb) self-propelled trench compactor. . . . . 25%

**Machine Sizing**

1372 mm (54 in) Forks

**Operating Load at Full Turn\***

<b>Model</b>	<b>kg</b>	<b>lb</b>
<b>926M Standard</b>	2819	<b>6214</b>
<b>930M Standard</b>	3195	<b>7043</b>
<b>938M Standard</b>	3846	<b>8478</b>

- Water pipes: 1309 kg (2885 lb)
  - 926M Standard ... 1 pipe — no problem
  - 930M ... 1 pipe — no problem
  - 938M ... 1 pipe — no problem
- Storm sewer pipes: 1556 kg (3430 lb)
  - 926M Standard ... 1 pipe — no problem
  - 930M ... 1 pipe — no problem
  - 938M ... 1 pipe — no problem

## Performance Series Buckets

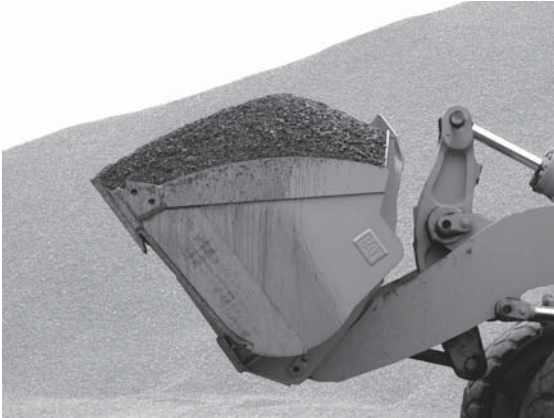

Performance Series Buckets utilize a system-based approach to balance bucket shape against the machine's linkage, weight, lift and tilt capacities. The result is a bucket optimized for performance and productivity, and intended for use in production applications. Performance Series Buckets for Wheel Loaders are designed for use in truck loading, stockpiling and load-and-carry applications. Performance is improved over current buckets in these production applications with materials such as sand, gravel and aggregates.

## Loads Easy

Proven design characteristics improve material flow into the bucket and improve material retention during transport. In some situations, the number of passes required to fill a truck is reduced. Performance Series Buckets are designed for optimum performance on the machine. Profile changes (over current buckets) improve loadability and make Performance Series Buckets machine-specific.

## Fuel Efficient

Performance Series Buckets have a longer floor — easily digging through the pile. Less time in the pile equals less fuel consumed.

## Higher Fill Factors

When comparing buckets of the same rated capacity, Performance Series Buckets have higher fill factors — up to 115%.

## Move More Material with the Same Rated Capacity

More material can be moved with a Performance Series Bucket compared to a same-size rated capacity current bucket. Likewise, a smaller Performance Series Bucket can be utilized to move the same amount of material as a larger rated capacity current bucket.

## Carries More

### Productive

Bucket shape and strike plane angle are designed for material retention and consistent load sizes. More material loads into the bucket and is carried all the way to the truck, hopper or stockpile.

A spill guard diverts overflow away from hinge pins, lift arms, hydraulic cylinders and tilt sensors helping to protect these areas of the machine.

## Bucket Specifications

Performance Series Buckets are designed to bring optimum performance to a specific machine. Profile changes over current buckets allow higher fill factors and increased production.

### Incompatibility on the 950H and 962H

The recent linkage change on the 950K and 962K has created some incompatibility issues with the Fusion Performance Series Buckets. Because the bucket shape has been optimized for the machine linkage, Fusion Performance Series Buckets designed for use on the 950K and 962K will experience interference with the linkage on the 950H and 962H. For this reason 950K and 962K Performance Series Buckets should NOT be used on the 950H and 962H machines.

### Incompatibility on the 966H/K/M

Because 972H/K/M Performance Series Buckets are designed specifically for performance on the 972H/K/M — their shape brings some incompatibilities with the 966H/K/M machine. These buckets can be pinned on to the 966H, but will experience interference with machine linkage in the rack back position. For this reason, 972H/K/M Performance Series Buckets should **not** be used on 966H/K/M machines. This is different than current General Purpose Buckets.

### Certain Bucket Sizes Require Additional Counterweight

Compared to a current bucket of the same rated capacity, Performance Series Buckets will move more material. To maintain appropriate machine stability, 980H machines utilizing the two larger Performance Series Buckets must be equipped with the aggregate loader counterweight. This is required for machine stability based on the bucket size/fill factor combination.

### Compatible with G and G II Machines

Performance Series Buckets for 988-size machines are compatible with standard and high lift linkages on G and G II Series machines.

### Medium Wheel Loader Aggregate Handler

Aggregate packages are specialized offerings for specific loose aggregate rehandling applications, such as truck loading, hopper charging, stockpiling, and load and carry. Rehandling loose aggregate is less stressful on the machine, therefore payloads can be increased above other applications by installing larger buckets, counterweights and a scale system such as the Cat Production Measurement system. To do so, the Cat aggregate packages require some prerequisites in terms of correct application, machine configuration and conformance to Caterpillar payload policy. Misapplication of Aggregate Handlers may result in significant reliability and durability risk.

**Material Handling Arm (MHA)**

The rated load for the MHA is 50% of the full turn static tipping load in each position or hydraulic or structural limitations. Manually extendable telescopic sections enable maximum lifting capacity at the full retracted position, and maximum lift height and reach in the fully extended position.

**Operating Load at Full Turn**

<b>Model</b>	<b>Retracted</b>	<b>Mid</b>	<b>Extended</b>
<b>910K</b>	1153 kg <b>2540 lb</b>	901 kg <b>1986 lb</b>	741 kg <b>1634 lb</b>
<b>914K</b>	1430 kg <b>3151 lb</b>	1122 kg <b>2472 lb</b>	925 kg <b>2037 lb</b>
<b>910M</b>	1313 kg <b>2893 lb</b>	1028 kg <b>2266 lb</b>	847 kg <b>1865 lb</b>
<b>914M</b>	1422 kg <b>3134 lb</b>	1116 kg <b>2459 lb</b>	920 kg <b>2026 lb</b>
<b>918M</b>	1597 kg <b>3520 lb</b>	1260 kg <b>2778 lb</b>	1042 kg <b>2297 lb</b>
<b>926M Standard</b>	1928 kg <b>4250 lb</b>	1635 kg <b>3605 lb</b>	1420 kg <b>3130 lb</b>
<b>930M Standard</b>	2182 kg <b>4811 lb</b>	1851 kg <b>4081 lb</b>	1607 kg <b>3543 lb</b>
<b>938M Standard</b>	2637 kg <b>5814 lb</b>	2241 kg <b>4940 lb</b>	1948 kg <b>4294 lb</b>

Storm sewer pipes:

1556 kg (3430 lb)

910K ... no

914K ... no

910M ... no

914M ... no

918M ... yes in retracted

926M ... yes in retracted and mid

930M ... yes in retracted, mid, and extended

938M ... yes in retracted, mid, and extended

Manhole boxes:

1361 kg (3000 lb)

910K ... no

914K ... yes in retracted

910M ... no

914M ... yes in retracted

918M ... yes in retracted

926M ... yes in retracted and mid

930M ... yes in retracted, mid, and extended

938M ... yes in retracted, mid, and extended

**Buckets**

All general purpose buckets are interchangeable on 926M-938M due to common attachment points on the quick couplers. Bucket selection will depend on the material density in your application. Offering multiple sized buckets allows the user the flexibility to closely match material density and bucket size with machine capability. Equipping a machine with too large a bucket will result in unacceptable stability — too small a bucket may provide inadequate tire coverage.

**Bucket 1780 kg/m<sup>3</sup> (3000 lb/yd<sup>3</sup>) ... 100% fill factor**

Model	Interface	Bucket Type	Width Range		Capacity Range		Weight Range		GET
			mm	in	m <sup>3</sup>	yd <sup>3</sup>	kg	lb	
926M	Fusion	General Purpose Performance Series	2550-2750	100-108	1.9-2.9	2.5-3.8	775-1042	1705-2292	J250/BOCE
		Light Material Side Dump	2750	108	3.1-5.0	4.1-6.5	1075-1357	2370-2992	J250/BOCE
		High Dump	3105	122	1.9	2.5	1653	3644	BOCE Included
		Grapple	2550-2743	100-108	3.0-3.5	3.9-4.6	1706-1796	3761-3960	BOCE Included
		Woodchip	2697	106	2.5-2.6	3.3-3.4	1585-1673	3495-3688	J250/BOCE
		Grading	3330	131	4.9-5.3	6.4-6.9	1717-1775	3785-3913	BOCE Included
		Sand & Gravel	2700	106	1.9	2.5	1233	2716	BOCE Included
		Waste	2750	108	2.5-2.9	3.2-3.8	1011-1127	2228-2485	J250/BOCE
	Pin On	General Purpose Performance Series	2550	100	1.7-2.5	2.2-3.2	775-979	1708-2154	J250/BOCE
		Light Material High Dump	2750	108	3.1-5.0	4.0-6.5	1096-1380	2416-3043	J250/BOCE
		Doze	2550-3060	100-120	3.0-5.0	4.0-6.5	1738-2149	3832-4738	BOCE Included
		Load & Carry	2743	108	4.2	5.5	1506	3321	BOCE
		Sand & Gravel	2743	108	4.6	6.0	1528	3369	BOCE
		Waste	2750	108	2.5-2.9	3.2-3.8	1026-1279	2262-2820	J250/BOCE
			2743	108	4.4	5.7	1528	3369	BOCE/Rubber
930M	Fusion	General Purpose Performance Series	2550-2750	100-108	1.9-2.9	2.5-3.8	775-1042	1705-2292	J250/BOCE
		Light Material Side Dump	2750	108	3.1-5.0	4.1-6.5	1075-1358	2370-2992	J250/BOCE
		High Dump	3105	122	1.9	2.5	1653	3644	BOCE Included
		Grapple	2550-2743	100-108	3.0-3.5	3.9-4.6	1706-1796	3761-3960	BOCE Included
		Woodchip	2697	106	2.5-2.6	3.3-3.4	1585-1673	3495-3688	J250/BOCE
		Grading	3330	131	4.9-5.3	6.4-6.9	1717-1775	3785-3913	BOCE Included
		Sand & Gravel	2700	106	1.9	2.5	1233	2716	BOCE Included
		Waste	2750	108	2.5-2.9	3.2-3.8	1011-1127	2228-2485	J250/BOCE
	Pin On	General Purpose Performance Series	2550	100	1.7-2.5	2.2-3.2	775-979	1708-2154	J250/BOCE
		Light Material High Dump	2750	108	3.1-5.0	4.0-6.5	1096-1380	2416-3043	J250/BOCE
		Doze	2550-3060	100-120	3.0-5.0	4.0-6.5	1738-2149	3832-4738	BOCE Included
		Load & Carry	2743	108	4.2	5.5	1506	3321	BOCE
		Sand & Gravel	2743	108	4.6	6.0	1528	3369	BOCE
		Waste	2750	108	2.5-2.9	3.2-3.8	1026-1279	2262-2820	J250/BOCE
			2743	108	4.4	5.7	1528	3369	BOCE/Rubber

Model	Interface	Bucket Type	Width Range		Capacity Range		Weight Range		GET
			mm	in	m <sup>3</sup>	yd <sup>3</sup>	kg	lb	
938M	Fusion	General Purpose Performance Series	2550-2750	100-108	1.9-2.9	2.5-3.8	775-1042	1705-2292	J250/BOCE
		Light Material	2750	108	3.1-5.0	4.0-6.5	1075-1502	2370-3311	J250/BOCE
		Side Dump	3105	122	1.9	2.5	1653	3644	BOCE Included
		High Dump	2550-3060	100-120	3.0-5.0	3.9-6.5	1710-2123	3770-4680	BOCE Included
		Grapple	2697	106	2.5-2.6	3.3-3.4	1585-1673	3495-3688	J250/BOCE
		Waste	2927	115	3.8-5.2	5-6.75	1854-2670	4088-5887	BOCE Included
		Woodchip	3330	131	5.6	7.3	1795	3957	BOCE Included
		Sand & Gravel	2750	108	2.5-3.2	3.2-4.2	1149-1265	2532-2788	J250/BOCE
	Pin On	General Purpose Performance Series	2550-2750	100-108	2.5-2.9	3.2-3.8	979-1202	2154-2649	J250/BOCE
		Light Material	2750	108	3.5-5.0	4.5-6.5	1178-1502	2596-3311	BOCE Included
		High Dump	3060	120	4.1-5.0	5.4-6.5	2065-2147	4553-4733	BOCE Included
		Doze	2927	115	4.6	6.0	1854	4088	BOCE
		Load & Carry	2927	115	5.2	6.75	1927	4249	BOCE
		Sand & Gravel	2750	108	2.7-3.2	3.5-4.2	1108-1279	2443-2820	J250/BOCE
950M 962M 950K 962K	Fusion	General Purpose Performance Series	2894	114	2.7-3.8	3.5-5.0	1367-1633	3014-3600	K80/BOCE
		Material Handling Performance Series	2894	114	2.7-3.8	3.5-5.0	1373-1650	3027-3638	K80/BOCE
		Multi-Purpose	2943	116	2.9	3.75	2087	4601	BOCE Included
		Side Dump	3220	127	2.9	3.75	2348	5177	BOCE Included
		High Dump	2910	115	4.6-6.1	6.0-8.0	2672-2784	5891-6139	BOCE Included
		Grapple	3059	120	4.6	6.0	2824	6226	BOCE Included
		Waste	3059	120	5.2-6.1	6.75-8.0	2115-2285	4663-5038	BOCE Included
		Woodchip	3330	131	9.2-9.9	12.0-13.0	2371-2466	5227-5437	BOCE Included
	Pin On	General Purpose Performance Series	2894	114	2.7-3.8	3.5-5.0	1472-1778	3245-3920	K80/BOCE
		Material Handling Performance Series	2894	114	2.7-3.8	3.5-5.0	1495-1787	3296-3940	K80/BOCE
		Rock Performance Series	2969	117	2.9-3.2	3.75-4.25	1992-2070	4711-4893	K90
		Multi-Purpose	2943	116	2.9	3.75	2099	4628	BOCE Included
		Side Dump	3226	127	2.9	3.75	2455	5413	BOCE Included
		High Dump	2910	115	4.6-6.1	6.0-8.0	2697-2812	5947-6201	BOCE Included
		Grapple	3059	120	4.6	6.0	2925	6449	BOCE Included
		Waste	3059	120	5.2-6.1	6.75-8.0	2250-2425	4960-5346	BOCE Included
		Woodchip	3330	131	9.2-9.9	12.0-13.0	2418-2516	5331-5547	BOCE Included
		Doze	3059	121	5.2	6.75	2273	5012	BOCE
		Load & Carry	3059	121	6.1	8.0	2604	5742	BOCE

Model	Interface	Bucket Type	Width Range		Capacity Range		Weight Range		GET
			mm	in	m <sup>3</sup>	yd <sup>3</sup>	kg	lb	
966M 966L 966K	Fusion	General Purpose Performance Series	3201	126	3.8-4.6	5.0-6.0	1965-2143	4332-4721	K90/BOCE
		Material Handling Performance Series	3201	126	4.0-4.8	5.2-6.3	2068-2254	4559-4969	K90/BOCE
		Coal Performance Series	3447	136	7.1	9.25	2865	6316	BOCE Included
		Rock Performance Series	3255	128	3.4	4.5	2084	4595	K90
		Multi-Purpose	3220	127	3.1	4.0	2785	6140	BOCE Included
		Side Dump	3677	145	3.6	4.75	2832	6243	BOCE Included
		High Dump	3059	120	5.4	7.0	2862	6310	BOCE Included
		Grapple	3048	120	3.8	5.0	4380	9656	K90
		Waste	3323	131	6.5	8.5	2569	5664	BOCE Included
		Woodchip	3943	155	9.9	13.0	2543	5606	BOCE Included
	Pin On	General Purpose Performance Series	3201	126	3.8-4.6	5.0-6.0	2112-2260	4656-4982	K90/BOCE
		Material Handling Performance Series	3201	126	4.0-4.8	5.25-6.25	2173-2350	4791-5181	K90/BOCE
		Coal Performance Series	3447	136	7.1	9.25	2795	6162	BOCE Included
		Rock Performance Series	3255	128	3.4	4.5	2362	5207	K90
		Heavy Duty Rock	3251	128	3.6-4.0	4.75-5.25	2371-2751	5227-6065	J350/K90
		Multi-Purpose	3226	127	3.1	4.0	2721	5999	K90
		Side Dump	3677	145	3.6	4.75	2858	6301	BOCE Included
		Waste	3357	132	6.5	8.5	2925	6449	BOCE Included
		Woodchip	3327-3937	131-155	8.0-9.9	10.5-13.0	2474-2543	5455-5542	BOCE Included
Doze	3357	132	6.5	8.5	3104	6844	BOCE Included		
Load & Carry	3357	132	7.5	9.75	3311	7301	BOCE Included		



Model	Interface	Bucket Type	Width Range		Capacity Range		Weight Range		GET		
			mm	in	m <sup>3</sup>	yd <sup>3</sup>	kg	lb			
972M 972L 972K	Fusion	General Purpose Performance Series	3201	126	4.2-5.0	5.5-6.5	2026-2233	4467-4923	K90/BOCE		
		Material Handling Performance Series	3201	126	5.2	6.75	2274	5013	K90/BOCE		
		Coal Performance Series	3447	136	7.1	9.25	3199	7053	BOCE Included		
		Rock Performance Series	3255	128	3.6	4.75	2079	4583	K90		
		Multi-Purpose	3220	127	3.1	4.0	2785	6140	BOCE Included		
		Side Dump	3677	145	3.6	4.75	2832	6243	BOCE Included		
		High Dump	3059	120	5.4	7.0	2862	6310	BOCE Included		
		Grapple	3048	120	3.8	5.0	4380	9656	K90		
		Waste	3323	131	6.5	8.5	2569	5664	BOCE Included		
		Woodchip	3943	155	9.9	13.0	2543	5606	BOCE Included		
		Doze	3357	132	6.5	8.5	3086	6805	BOCE Included		
		Load & Carry	3357	132	7.5	9.75	3311	7301	BOCE Included		
		Pin On	General Purpose Performance Series	General Purpose Performance Series	3193	126	4.2-5.0	5.5-6.5	2214-2383	4881-5254	K90/BOCE
				Material Handling Performance Series	3193	126	4.6-5.2	6.0-6.75	2269-2389	5002-5276	K90/BOCE
Coal Performance Series	3447			136	7.1	9.25	3203	7061	BOCE Included		
Rock Performance Series	3255			128	3.6-4.0	4.75-5.25	2250-2397	4960-5284	K90		
Heavy Duty Rock	3251			128	3.6-4.0	4.75-5.25	2371-2751	5227-6065	J350/K90		
Multi-Purpose	3226			127	3.1	4.0	2721	5999	K90		
Side Dump	3677			145	3.6	4.75	2858	6301	BOCE Included		
Waste	3357			132	6.5	8.5	2925	6449	BOCE Included		
Woodchip	3327-3937			131-155	8.0-9.9	10.5-13.0	2474-2514	5455-5542	BOCE Included		
Slag	3250			128	3.4	4.5	4145	9138	K100		
Doze	3357			132	6.5	8.5	3104	6844	BOCE Included		
Load & Carry	3357			132	7.5	9.75	3311	7301	BOCE Included		

Model	Interface	Bucket Type	Width Range		Capacity Range		Weight Range		GET
			mm	in	m <sup>3</sup>	yd <sup>3</sup>	kg	lb	
980M 980L 980K	Pin On	General Purpose Performance Series	3405	134	5.4-6.0	7.0-7.85	2674-2853	5895-6290	K90/BOCE
		Material Handling Performance Series	3405	134	5.7	7.5	2882	6354	K90/BOCE
		Coal Performance Series	3638	143	8.2	10.75	3663	8075	BOCE Included
		Rock Performance Series	3495	138	4.4	5.75	2925	6448	K90
		Heavy Duty Quarry Rock	3505-3568	138-140	4.4-4.6	5.75-6.0	3306-3686	7288-8125	BOCE Included
		Waste	3886	153	9.8	12.75	3908	8615	BOCE Included
		Woodchip	4166	164	11.5	15.0	3887	8570	BOCE Included
		Doze	3882	153	13.0	9.9	4210	9283	BOCE Included
		Load & Carry	3882	153	14.0	10.7	4438	9786	BOCE Included
		Slag	3394	134	3.8	5.0	5302	11,689	K130
982M	Pin On	General Purpose Performance Series	3568	141	5.8-6.4	7.5-8.25	3254-3451	7174-7608	K100
		General Purpose Abrasion Performance Series	3568	141	6.4-8.2	8.25-10.75	3406-3829	7509-8442	K100
		Heavy Duty General Purpose Performance Series	3608	142	6.1-7.5	8.0-9.75	3862-4239	8514-9345	K100
		Material Handling Performance Series	3568	141	6.40	8.25	3515	7749	K100
		Heavy Duty Material Handling Performance Series	3608	142	6.4-7.0	8.25-9.25	4204-4407	9270-9717	K100
		Coal Performance Series	3638	143	8.80	11.50	4016	8854	BOCE Included
		Rock Performance Series	3674	144	4.9-5.4	6.5-7.0	3759-3845	8286-8477	K100
		Heavy Duty Quarry Rock Performance Series	3674	144	4.9-5.8	6.5-7.5	4158-4510	9167-9943	K100
		Waste Handling	3882	153	10.20	13.25	4895	10,792	BOCE Included
		Woodchip	4174	164	12.00	15.75	4680	10,318	BOCE Included

Model	Interface	Bucket Type	Width Range		Capacity Range		Weight Range		GET
			mm	in	m <sup>3</sup>	yd <sup>3</sup>	kg	lb	
986H	Pin On	General Purpose Performance Series	3695	145	6.1-7.7	8.0-10.0	3648-4065	8042-8962	K110
		Rock Performance Series	3772	149	5.4-6.1	7.0-8.0	3726-3941	8214-8688	K110
		Heavy Duty Rock Performance Series	4014	158	5.4	7.0	5061	11,158	K130
		Extreme Duty Rock	4146	163	5.0	6.5	5195	12,050	K130
		Serrated Edge Rock	3812	150	6.1	8.0	4232	9330	N/A
		Coal	3692	145	10.0	13.5	5195	11,453	BOCE Included
988K	Pin On	General Purpose Performance Series	3855	152	6.9-8.4	9.0-11.0	4539-4994	10,007-11,010	K110
		Rock Performance Series	4020	158	6.4-7.7	8.3-10.0	4880-5263	10,759-11,603	K130
		Heavy Duty Rock Performance Series	4080	161	6.4	8.3	6360	14,021	K130
		Heavy Duty Granite Performance Series	3986	157	6.4	8.3	7433	16,385	K130
		Serrated Edge Rock	3968	156	6.4-6.9	8.3-9.0	5455-5634	12,026-12,421	N/A
		Iron Ore	3922	154	4.7	6.2	5771	12,723	K130
		Coal	4120	162	11.5-13.0	15.0-17.0	6023-6435	13,278-14,186	BOCE Included
		Slag	3900-4032	154-159	5.4-6.4	7.0-8.3	7633-8454	16,828-18,638	J600/Serrated Edge

N/A = Not Applicable

Model	Interface	Bucket Type	Width Range		Capacity Range		Weight Range		GET
			mm	in	m <sup>3</sup>	yd <sup>3</sup>	kg	lb	
990K	Pin On	Rock Performance Series	4610	182	8.6-10.0	11.25-13.0	7247-7497	15,977-16,528	K130
		Heavy Duty Rock Performance Series	4670	184	8.6	11.25	8980	19,798	K130
		Heavy Duty Granite Performance Series	4634	182	8.6	11.25	12 055	26,520	K150
		Slag	4450-4500	175-177	8.5-9.2	11.2-12.0	9149-9613	20,127-21,149	Weld-on edge included
		Coal	4370	172	13.4	17.5	7460	16,410	BOCE Included
		Iron Ore	4450	175	7.0	9.2	8525	18,750	K150
		Serrated Edge Rock	4610	182	9.5	12.4	8140	17,910	N/A
992K	Pin On	Rock	4824-4884	190-192	10.7-12.2	14.0-16.0	9382-10 574	20,684-23,262	K150/K170
		Heavy Duty Rock	5068	200	10.7	14.0	11 560	25,485	K170
		High Abrasion Rock	5068	200	10.7	14.0	11 927	26,295	K150
		Heavy Duty Granite	5165	203	10.7	14.0	13 720	30,247	K150
		Coal	6170	243	19.0	25.0	12 504	27,506	BOCE Included
		Iron Ore	4900	193	9.0	11.8	11 172	24,577	K150
		Serrated Edge Rock	4824	190	12.3	16.0	10 282	22,620	N/A
993K	Pin On	Rock	5068	200	12.2-14.5	16.0-19.0	12 864-14 209	28,301-31,260	K170
		High Abrasion Rock	5160	203	12.2-13.0	16.0-17.0	15 205-15 456	33,451-34,004	K170
		Heavy Duty Granite	5160	203	13.0	17.0	17 418	38,320	K170
		Coal	6300	248	23.0	31.0	17 673	38,880	K170
		Iron Ore	5160	203	10.0	13.0	14 063	30,940	K170
		Serrated Edge Rock	5080	200	15.0	19.5	13 915	30,615	N/A
994K	Pin On	Rock	6223	245	19.1-24.5	25-32	19 205-21 293	42,340-46,942	Spade edge*
		Heavy Duty Rock	6240	246	19.1-21.4	25-28	20 699-21 303	45,633-46,966	Spade edge*
		Coal	6964	274	32.1-39.8	42-52	20 862-22 773	45,992-50,206	Straight edge*
		Iron Ore	6240	246	17.2	22.5	19 518	43,029	Spade edge*

\*With teeth and segments.  
N/A = Not Applicable

Model	Interface	Bucket Type	Width Range		Capacity Range		Weight Range		GET
			mm	in	m <sup>3</sup>	yd <sup>3</sup>	kg	lb	
<b>926M</b> <b>924K</b>	Fusion	General Purpose	2550-2750	<b>100-108</b>	2.0-2.9	<b>2.6-3.8</b>	825-1040	<b>1709-2297</b>	J250/BOCE
		Light Material	2750	<b>108</b>	3.5-5.0	<b>4.6-6.5</b>	1158-1357	<b>2553-2992</b>	BOCE
		High Dump	2550-2750	<b>100-108</b>	3.0-3.5	<b>3.9-4.6</b>	1706-1796	<b>3761-3960</b>	BOCE
	Pin On	General Purpose	2550	<b>100</b>	1.8-2.3	<b>2.4-3.0</b>	810-891	<b>1786-1964</b>	J250/BOCE
		Light Material	2750	<b>108</b>	3.5-5.0	<b>4.6-6.5</b>	1178-1380	<b>2598-3042</b>	BOCE
		High Dump	2550-3060	<b>100-120</b>	3.0-5.0	<b>4.0-6.5</b>	1738-2149	<b>3832-4738</b>	BOCE
<b>930M</b> <b>930K</b>	Fusion	Sand & Gravel	2750	<b>108</b>	2.6-2.7	<b>3.4-3.5</b>	1065	<b>2348</b>	J250/BOCE
		Waste	2750	<b>108</b>	4.6	<b>6.0</b>	1528	<b>3369</b>	BOCE
		General Purpose	2550-2750	<b>100-108</b>	2.0-2.9	<b>2.6-3.8</b>	825-1040	<b>1709-2297</b>	J250/BOCE
		Light Material	2750	<b>108</b>	3.5-5.0	<b>4.6-6.5</b>	1158-1357	<b>2553-2992</b>	BOCE
		High Dump	2550-2750	<b>100-108</b>	3.0-3.5	<b>3.9-4.6</b>	1706-1796	<b>3761-3960</b>	BOCE
	Charcoal	3060	<b>120</b>	5.0	<b>6.5</b>	1282	<b>2826</b>	BOCE	
Pin On	General Purpose	2550	<b>100</b>	2.0-2.5	<b>2.6-3.2</b>	854-977	<b>1883-2154</b>	J250/BOCE	
	Light Material	2750	<b>108</b>	3.5-5.0	<b>4.6-6.5</b>	1178-1380	<b>2597-3042</b>	BOCE	
	High Dump	2550-3060	<b>100-120</b>	3.0-5.0	<b>4.0-6.5</b>	1738-2149	<b>3832-4738</b>	BOCE	
	Sand & Gravel	2750	<b>108</b>	2.6-2.7	<b>3.4-3.5</b>	1065	<b>2348</b>	J250/BOCE	
	Waste	2750	<b>108</b>	4.6	<b>6.0</b>	1528	<b>3369</b>	BOCE	
<b>938M</b> <b>938K</b>	Fusion	General Purpose	2550-2750	<b>100-108</b>	1.9-2.9	<b>2.5-3.8</b>	775-1042	<b>1705-2292</b>	J250/BOCE
		Light Material	2750	<b>108</b>	2.4-5.0	<b>3.1-6.5</b>	962-1360	<b>2120-2992</b>	BOCE
		High Dump	3060	<b>120</b>	4.1-5.0	<b>5.4-6.5</b>	2123-2126	<b>4680-4687</b>	BOCE
		Sand & Gravel	2750	<b>108</b>	2.5-3.2	<b>3.2-4.1</b>	1011-1127	<b>2228-2485</b>	J250/BOCE
	Pin On	General Purpose	2750	<b>108</b>	2.5-2.9	<b>3.2-3.8</b>	968-1059	<b>2134-2330</b>	J250/BOCE
		Light Material	2750-3060	<b>108-120</b>	3.5-5.5	<b>4.5-7.2</b>	1178-1718	<b>2596-3788</b>	BOCE
	High Dump	3060	<b>120</b>	4.1-5.0	<b>5.3-6.5</b>	2065-2147	<b>4553-4733</b>	BOCE	
	Sand & Gravel	2750	<b>108</b>	2.7-3.2	<b>3.5-4.2</b>	1108-1279	<b>2443-2820</b>	J250/BOCE	
	Waste	2827	<b>115</b>	5.0	<b>6.75</b>	1528	<b>3369</b>	BOCE	

Model	Interface	Bucket Type	Width Range		Capacity Range		Weight Range		GET
			mm	in	m <sup>3</sup>	yd <sup>3</sup>	kg	lb	
950H 962H	Fusion	General Purpose Performance Series	2894	114	2.9-3.4	3.75-4.5	1534-1610	3382-3549	K80/BOCE
		Material Handling	2894	114	3.6-3.8	4.75-5.0	1701	3750	K80/BOCE
		Coal	3302	130	5.7-5.9	7.5-7.75	1928	4251	BOCE
		Rock	2969	117	2.7-3.25	3.75-4.25	1588-1638	3500-3611	K90
		Multi-Purpose	2943	116	2.9	3.75	2087	4601	BOCE Included
		Side Dump	3220	127	2.9	3.75	2348	5177	BOCE Included
		High Dump	2910	115	4.6-6.1	6.0-8.0	2672-2784	5891	BOCE Included
		Grapple	3059	120	4.6	6.0	2824	6139	K80
	Waste Handling	3059	120	5.2	6.75	2197	4844	BOCE Included	
	Woodchip	3330	131	9.2	12.0	2238	4934	BOCE Included	
	Pin On	General Purpose Performance Series	2894	114	2.5-3.4	3.5-4.75	1419-1636	3128-3607	K80/BOCE
		Material Handling Performance Series	2894	114	3.0-3.8	4.0-5.0	1538-1684	3391-3713	K80/BOCE
		Coal Performance Series	3040-3059	120	4.2-5.2	5.5-6.75	1889-2069	4165-4559	BOCE Included
		Rock Performance Series	2972	117	2.9-3.3	3.75-4.25	1796-1838	3560-4052	K90
Multi-Purpose		2929	115	2.9	3.75	2014	4440	BOCE Included	
Side Dump		3219	127	2.9	3.75	2425	5346	BOCE Included	
Waste Handling		3059	120	5.2	6.75	2541	5602	BOCE Included	
966H	Fusion	General Purpose Performance Series	3201	126	3.6-4.6	4.75-6.0	1965-2143	4332-4724	K90/BOCE
		Material Handling Performance Series	3201	126	3.8-4.8	5.0-6.3	2068-2254	4559-4969	K90/BOCE
		Coal Performance Series	3447	136	6.9-7.1	9.0-9.25	2865	6316	BOCE Included
		Rock Performance Series	3255	128	3.2-3.4	4.25-4.5	2084	4595	K90
	Pin On	General Purpose Performance Series	3201	126	3.6-4.6	4.75-6.0	2112-2260	4656-4982	K90/BOCE
		Material Handling Performance Series	3201	126	3.8-4.8	5.0-6.3	2173-2350	4791-5181	K90/BOCE
		Coal Performance Series	3447	136	6.9-7.1	9.0-9.25	2795	6162	BOCE Included
		Rock Performance Series	3255	128	3.2-3.4	4.25-4.5	2362	5207	K90

Model	Interface	Bucket Type	Width Range		Capacity Range		Weight Range		GET
			mm	in	m <sup>3</sup>	yd <sup>3</sup>	kg	lb	
972H	Fusion	General Purpose Performance Series	3201	126	4.0-5.0	5.25-6.5	2026-2212	4467-4877	K90/BOCE
		Material Handling Performance Series	3201	126	5.0-5.2	6.5-6.75	2274	5013	K90/BOCE
		Coal Performance Series	3447	136	6.9-7.1	9.0-9.25	3199	7053	BOCE Included
		Rock Performance Series	3225	128	3.4-3.6	4.5-4.75	2079	4583	K90
	Pin On	General Purpose Performance Series	3201	126	4.0-5.0	5.25-6.5	2214-2315	4881-5104	K90/BOCE
		Material Handling Performance Series	3201	126	4.4-5.2	5.75-6.75	2269-2389	5002-5267	K90/BOCE
		Coal Performance Series	3447	136	6.9-7.1	9.0-9.25	3203	7061	BOCE Included
		Rock Performance Series	3255	128	3.4-4.0	4.5-5.25	2250-2397	4960-5284	K90
966H 972H	Fusion	Multi-Purpose	3220	127	2.9-3.1	3.75-4.0	2892	6375	BOCE Included
		Side Dump	3677	145	3.4-3.6	4.5-4.75	2832	6243	BOCE Included
		High Dump	3059	120	5.0-5.4	6.5-7.0	2904	6402	BOCE Included
		Grapple	3048	120	3.2-3.6	4.25-4.75	4380	9656	K90/BOCE
		Waste	3357	132	6.2-6.5	8.1-8.5	2569	5664	BOCE Included
		Woodchip	3937	155	9.6-9.9	12.5-13.0	2543	5606	BOCE Included
	Pin On	Heavy Duty Rock	3251	125	3.4-4.0	4.5-5.25	2425-2949	5346-6501	K90/J350
		Multi-Purpose	3220	127	2.9-3.1	3.75-4.0	2806	6185	BOCE Included
		Side Dump	3677	145	3.4-3.6	4.5-4.75	2836	6252	BOCE Included
		Waste	3357	132	5.7-6.0	7.5-7.85	2837	6255	BOCE Included
		Woodchip	3327-3937	131-155	7.6-9.9	10.0-13.0	2474-2514	5455-5542	BOCE Included
980H	Pin On	General Purpose Performance Series	3405	134	5.0-6.1	6.5-8.0	2572-2726	5670-6010	K100/BOCE
		Material Handling Performance Series	3405	134	5.5-5.7	7.25-7.5	2780	6129	K100/BOCE
		Coal Performance Series	3638	143	7.8-8.2	10.25-10.75	3213	7083	BOCE Included
		Rock Performance Series	3492	137	4.0-4.4	5.25-5.75	2801	6175	K100
		Heavy Duty General Purpose	3450	136	5.4-5.7	7.0-7.5	3439	7582	BOCE
		Heavy Duty Quarry Rock	3505-3568	138-140	4.0-4.6	5.75-6.0	3306-3686	7288-8125	K110
		Slag	3394	134	3.8	5.0	5302	11,689	K130
		Waste — Load & Carry	3882	153	10.7	14.0	4438	9786	BOCE Included
		Waste — Dozing	3882	153	9.9	13.0	4210	9283	BOCE Included
		Woodchip	4166	164	11.5	15.0	3887	8570	BOCE Included

Model	Interface	Bucket Type	Width Range		Capacity Range		Weight Range		GET
			mm	in	m <sup>3</sup>	yd <sup>3</sup>	kg	lb	
986H	Pin On	General Purpose Performance Series	3695	145	6.1-7.7	8.0-10.0	3648-4065	8042-8962	K110
		Rock Performance Series	3772	149	5.4-6.1	7.0-8.0	3726-3941	8214-8688	K110
		Heavy Duty Rock Performance Series	4014	158	5.4	7.0	5061	11,158	K130
		Extreme Duty Rock	4146	163	5.0	6.5	5195	12,050	K130
		Serrated Edge Rock	3812	150	6.1	8.0	4232	9330	N/A
		Coal	3692	145	10.0	13.5	5195	11,453	BOCE Included
988K	Pin On	General Purpose Performance Series	3855	152	6.9-8.4	9.0-11.0	4539-4994	10,007-11,010	K110
		Rock Performance Series	4020	158	6.4-7.7	8.3-10.0	4880-5263	10,759-11,603	K130
		Heavy Duty Rock Performance Series	4080	161	6.4	8.3	6360	14,021	K130
		Heavy Duty Granite Performance Series	3986	157	6.4	8.3	7433	16,385	K130
		Serrated Edge Rock	3968	156	6.4-6.9	8.3-9.0	5455-5634	12,026-12,421	N/A
		Iron Ore	3922	154	4.7	6.2	5771	12,723	K130
		Coal	4120	162	11.5-13.0	15.0-17.0	6023-6435	13,278-14,186	BOCE Included
		Slag	3900-4032	154-159	5.4-6.4	7.0-8.3	7633-8454	16,828-18,638	J600/Serrated Edge

N/A = Not Applicable



# Wheel Loaders Integrated Toolcarriers

# Buckets ● Americas South

Model	Interface	Bucket Type	Width Range		Capacity Range		Weight Range		GET
			mm	in	m <sup>3</sup>	yd <sup>3</sup>	kg	lb	
990K	Pin On	Rock Performance Series	4610	182	8.60-10.0	11.25-13.0	7247-7497	15,977-16,528	K130
		Heavy Duty Rock Performance Series	4670	184	8.60	11.25	8980	19,798	K130
		Heavy Duty Granite Performance Series	4634	182	8.60	11.25	12 055	26,520	K150
		Iron Ore	4670	184	7.5	9.7	8476	18,686	K150
		Coal	4500	177	15.0	19.5	7986	17,606	BOCE Included
		Slag	4500-4708	177-185	8.6-9.2	11.2-12.0	9664-11 276	21,305-24,859	K130 — Weld-on Edge Included
		Serrated Edge Rock	4610	182	9.5	12.5	8179	18,031	N/A
992K	Pin On	Rock	4824-4884	190-192	10.7-12.2	14.0-16.0	9382-10 574	20,684-23,262	K150/K170
		Heavy Duty Rock	5068	200	10.7	14.0	11 560	25,485	K170
		High Abrasion Rock	5068	200	10.7	14.0	11 927	26,295	K150
		Heavy Duty Granite	5165	203	10.7	14.0	13 720	30,247	K150
		Coal	6170	243	19.0	25.0	12 504	27,506	BOCE Included
		Iron Ore	4900	193	9.0	11.8	11 172	24,577	K150
		Serrated Edge Rock	4824	190	12.3	16.0	10 282	22,620	N/A
993K	Pin On	Rock	5068	200	12.2-14.5	16.0-19.0	12 864-14 209	28,301-31,260	K170
		High Abrasion Rock	5160	203	12.2-13.0	16.0-17.0	15 205-15 456	33,451-34,004	K170
		Heavy Duty Granite	5160	203	13.0	17.0	17 418	38,320	K170
		Coal	6300	248	23.0	31.0	17 673	38,880	K170
		Iron Ore	5160	203	10.0	13.0	14 063	30,940	K170
		Serrated Edge Rock	5080	200	15.0	19.5	13 915	30,615	N/A
994K	Pin On	Rock	6223	245	19.1-24.5	25-32	19 205-21 293	42,340-46,942	Spade edge*
		Heavy Duty Rock	6240	246	19.1-21.4	25-28	20 699-21 303	45,633-46,966	Spade edge*
		Coal	6964	274	32.1-39.8	42-52	20 862-22 773	45,992-50,206	Straight edge*
		Iron Ore	6240	246	17.2	22.5	19 518	43,029	Spade edge*

\*With teeth and segments.  
N/A = Not Applicable

Model	Interface	Bucket Type	Width Range		Capacity Range		Weight Range		GET
			mm	in	m <sup>3</sup>	yd <sup>3</sup>	kg	lb	
926M 924K	Fusion	General Purpose	2550	100	1.9-2.5	2.5-3.3	775-961	1705-2119	J250/BOCE
		Light Material	2750	108	3.0-5.0	3.9-6.5	1075-1357	2370-2992	J250/BOCE
		High Dump	2550-3060	100-120	3.0-5.0	3.9-6.5	1710-2225	3770-4905	BOCE
		Sand & Gravel	2750	108	2.5-3.2	3.2-4.1	1011-1127	2228-2485	J250/BOCE
	ISO	General Purpose	2550-2750	100-108	2.1-2.5	2.7-3.3	792-915	1746-2017	J250/BOCE
		Grading	2600-2900	102-114	1.78-2.01	2.3-2.6	874-922	1867-2033	BOCE
		Light Material	2750	108	3.5-5.0	4.5-6.5	977-1297	2154-2454	J250/BOCE
		High Dump	2550-3060	100-120	3.0-5.0	3.9-6.5	1669-2182	3680-4810	BOCE
	Pin On	General Purpose	2550	100	1.9-2.5	2.5-3.2	812-979	1786-2154	J250/BOCE
		Light Material	2750	108	3.0-5.0	3.9-6.5	1094-1380	2412-3042	J250/BOCE
		High Dump	2550-3060	100-120	3.0-5.0	3.9-6.5	1742-2225	3800-4905	BOCE
		Sand & Gravel	2750	108	2.5-3.2	3.2-4.2	1026-1279	2262-2820	J250/BOCE
930M 930K	Fusion	General Purpose	2550	100	1.9-2.5	2.5-3.3	775-961	1705-2119	J250/BOCE
		Light Material	2750	108	3.0-5.0	3.9-6.5	1075-1357	2370-2992	J250/BOCE
		High Dump	2550-3060	100-120	3.0-5.0	3.9-6.5	1710-2225	3770-4905	BOCE
		Sand & Gravel	2750	108	2.5-3.2	3.2-4.1	1011-1127	2228-2485	J250/BOCE
	ISO	General Purpose	2550-2750	100-108	2.1-2.5	2.7-3.3	792-915	1746-2017	J250/BOCE
		Grading	2600-2900	102-114	1.78-2.01	2.3-2.6	874-922	1867-2033	BOCE
		Light Material	2750	108	3.5-5.0	4.5-6.5	977-1297	2154-2454	J250/BOCE
		High Dump	2550-3060	100-120	3.0-5.0	3.9-6.5	1669-2182	3680-4810	BOCE
	Pin On	General Purpose	2550	100	1.9-2.5	2.5-3.2	812-979	1786-2154	J250/BOCE
		Light Material	2750	108	3.0-5.0	3.9-6.5	1094-1380	2412-3042	J250/BOCE
		High Dump	2550-3060	100-120	3.0-5.0	3.9-6.5	1742-2225	3800-4905	BOCE
		Sand & Gravel	2750	108	2.5-3.2	3.2-4.1	1026-1279	2262-2820	J250/BOCE
938M 938K	Fusion	General Purpose	2550-2750	100-108	2.4-2.9	3.1-3.8	961-1042	2253-2992	J250/BOCE
		Light Material	2750	108	3.4-5.0	4.5-6.5	1158-1360	2553-2992	J250/BOCE
		High Dump	3065	120	4.1-5.0	5.4-6.5	2126-2225	4687-4905	BOCE
		Sand & Gravel	2750	108	2.7-3.2	3.5-4.1	1059-1127	2335-2485	J250/BOCE
	ISO	General Purpose	2550-2750	100-108	2.4-2.9	3.1-3.8	915-995	2017-2194	J250/BOCE
		Grading	2600-2900	102-114	1.78-2.01	2.3-2.6	847-922	1867-2033	BOCE
		Light Material	2750	108	3.5-5.0	4.5-6.5	1178-1297	2597-2859	J250/BOCE
		High Dump	3065	120	4.1-5.0	5.4-6.5	2084-2182	4594-4810	BOCE
	Pin On	General Purpose	2550-2750	100-108	2.4-2.9	3.1-3.8	977-1058	2154-2332	J250/BOCE
		Light Material	2750	108	3.5-5.0	4.5-6.5	1178-1378	2596-3038	BOCE
		High Dump	3065	120	4.1-5.0	5.3-6.5	2065-2147	4553-4733	BOCE
		Sand & Gravel	2750	108	2.7-3.2	3.5-4.2	1108-1279	2443-2820	J250/BOCE

N/A = Not Applicable

Model	Interface	Bucket Type	Width Range		Capacity Range		Weight Range		GET
			mm	in	m <sup>3</sup>	yd <sup>3</sup>	kg	lb	
950K	Fusion	General Purpose Performance Series	2894	114	2.9-3.6	3.79-4.7	1449-1550	3195-3417	K80/BOCE
		Material Handling Performance Series	2904-2994	114-117	3.1-3.4	4.05-4.45	1535-2070	3384-4564	K80/BOCE
	Pin On	General Purpose Performance Series	2894	114	2.9-3.6	3.79-4.7	1556-1683	3430-3710	K80/BOCE
		Material Handling Performance Series	2904-2994	114-117	3.1-3.4	4.05-4.45	1543-2060	3402-4541	K80/BOCE
		Rock Performance Series	2969	117	2.9	3.8	1992	4382	K90
		GD Skeleton	3100	122	3.0	3.9	1713	3777	N/A
HD Skeleton	3150	124	3.3	4.3	1897	4182	N/A		
962K	Fusion	General Purpose Performance Series	2894	114	3.2-3.6	4.18-4.7	1517-1550	3344-3417	K80/BOCE
		Material Handling Performance Series	2904-2994	114-117	3.3-3.8	4.32-4.79	1574-2183	3470-4812	K80/BOCE
	Pin On	General Purpose Performance Series	2894	114	3.2-3.6	4.18-4.7	1647-1683	3631-3710	K80/BOCE
		Material Handling Performance Series	2904-2994	114-117	3.3-3.8	4.32-4.79	1582-2173	3488-4790	K80/BOCE
		Rock Performance Series	2969	117	3.2	4.19	2070	4554	K90
		GD Skeleton	3100	122	3.0	3.9	1713	3777	N/A
HD Skeleton	3150	124	3.3	4.3	1897	4182	N/A		
966K	Fusion	General Purpose Performance Series	3201	126	3.6-4.6	4.75-6.0	1943-2082	4283-4590	K90/BOCE
		Material Handling Performance Series	3201	126	3.8-4.8	5.0-6.3	2068-2254	4559-4969	K90/BOCE
		Rock Performance Series	3252	128	3.2-3.4	4.25-4.5	2084	4595	K90
	Pin On	General Purpose Performance Series	3201	126	3.6-4.6	4.75-6.0	1985-2194	4367-4827	K90/BOCE
		Material Handling Performance Series	3000-3289	118-129	3.8-4.8	5.0-6.3	2100-3084	4620-6785	K90/BOCE
		Rock Performance Series	3252	128	3.2-3.4	4.25-4.5	2175	4785	K90
HD Skeleton	3300	130	3.9	5.1	2421	5337	N/A		

N/A = Not Applicable

Model	Interface	Bucket Type	Width Range		Capacity Range		Weight Range		GET
			mm	in	m <sup>3</sup>	yd <sup>3</sup>	kg	lb	
972K	Fusion	General Purpose Performance Series	3201	126	4.0-5.0	5.25-6.5	1966-2147	4325-4723	K90/BOCE
		Material Handling Performance Series	3201	126	4.4-5.2	5.72-6.76	1907-2274	4195-5003	K90/BOCE
		Rock Performance Series	3225	128	3.4-3.6	4.5-4.75	2099	4618	K90
	Pin On	General Purpose Performance Series	3201	126	4.0-5.0	5.25-6.5	2089-2281	4596-5018	K90/BOCE
		Material Handling Performance Series	3201-3294	126-130	4.4-5.2	5.75-6.75	2248-3122	4946-6868	K90/BOCE
		Rock Performance Series	3252-3350	128-132	3.4-4.0	4.5-5.25	2209-3039	4860-6686	K90/K100
986H	Pin On	General Purpose Performance Series	3695	145	6.1-7.6	8.0-10.0	3648-4121	8042-9085	K110
		Rock Performance Series	3812	150	5.4-6.1	7.0-8.0	3726-3941	8214-8688	K110
		Heavy Duty Rock Performance Series	4014	158	5.4	7.0	5061	11,158	K130
		Extreme Duty Rock	4146	163	5.0	6.5	5466	12,050	K130
		Serrated Edge Rock	3812	150	6.1	8.0	4232	9330	N/A
		Coal	3692	145	10.3	13.5	5088	11,217	BOCE Included
980K	Pin On	General Purpose Performance Series	3413	134	5.0-6.0	6.5-7.8	2572-2831	5670-6228	K100/BOCE
		Material Handling Performance Series	3413-3580	134-141	5.5-5.7	7.25-7.5	2786-4095	6149-9009	K100/BOCE
		Rock Performance Series	3510-3645	138-144	4.5-5.4	5.85-7.02	3058-4335	6728-9537	K100/K110

N/A = Not Applicable

Model	Interface	Bucket Type	Width		Capacity		GET
			mm	in	m <sup>3</sup>	yd <sup>3</sup>	
990K	Pin On	Rock	4610	181.5	9.2	12.0	Spade
		Rock	4450	175.2	8.6	11.2	Spade
		Heavy Duty Rock	5409	213.0	8.55	11.2	Spade
		Heavy Duty Granite	4636	182.5	8.6	11.2	Spade
		Iron Ore	4450	175.2	7.03	9.2	Spade
		Serrated Edge	4450	175.2	8.6	11.2	V-Edge
		Serrated Edge	4610	181.5	9.1	11.9	V-Edge
		Serrated Edge	4610	181.5	9.5	12.4	Serrated Spade
		Coal	4500	177.2	8.6	11.2	Straight
		Slag	4450	175.2	9.2	12.0	Serrated Spade
		Slag	4500	177.2	8.6	11.2	Serrated Spade
992G	Pin On	Serrated Edge	4826	190.0	11.5	15.0	V-Serrated
		Serrated Edge	4826	190.0	12.3	16.1	V-Serrated
992K	Pin On	Rock	4824	189.9	10.7	14.0	Spade
		Rock	4824	189.9	11.5	15.0	Spade
		Rock	4824	189.9	12.2	16.0	Spade
		Heavy Duty Rock	5080	200.0	10.7	14.0	Spade
		Heavy Duty Granite	5156	203.0	10.7	14.0	Spade
		Iron Ore	4900	192.9	9	11.8	Spade
		Serrated Edge	4824	189.9	12.3	16.1	V-Serrated
Coal	6170	242.9	18.9	24.7	Straight		
993K	Pin On	Rock	5080	200.0	12.2	16.0	Spade
		Rock	5080	200.0	13	17.0	Spade
		Rock	5080	200.0	13.8	18.0	Spade
		Rock	5080	200.0	14.5	19.0	Spade
		High Abrasion	5160	203.1	12.2	16.0	Spade
		High Abrasion	5160	203.1	13	17.0	Spade
		Heavy Duty Granite	5160	203.1	13	17.0	Spade
		Iron Ore	5160	203.1	10	13.1	Spade
		Serrated Edge	5080	200.0	14.9	19.5	V-Serrated
		Coal	6300	248.0	23.7	31.0	Straight
994K	Pin On	Rock	6223	245	19.1-24.5	25-32	Spade edge*
		Heavy Duty Rock	6240	246	19.1-21.4	25-28	Spade edge*
		Coal	6964	274	32.1-39.8	42-52	Straight edge*
		Iron Ore	6240	246	17.2	22.5	Spade edge*

\*With teeth and segments.

- Buckets
- Europe, Africa, Middle East
- High Dump Buckets

## Wheel Loaders Integrated Toolcarriers

Model	Capacity		Width		Weight		Dump Clearance				Maximum Material Density			
							Standard Lift		High Lift		Standard Lift		High Lift	
	m <sup>3</sup>	yd <sup>3</sup>	mm	in	kg	lb	mm	in	mm	in	kg/m <sup>3</sup>	lb/yd <sup>3</sup>	kg/m <sup>3</sup>	lb/yd <sup>3</sup>
950H	5.1	6.7	3000	118.1	2662	5869	4543	178.9	5147	202.6	873	1471	867	1461
	7.2	9.4	3200	126.0	3444	7593	4625	182.1	5247	206.6	550	927	552	930
	9.0	11.8	3400	133.9	3847	8481	4496	177.0	5126	201.8	404	681	410	691
950K	5.1	6.7	3000	118.1	2620	5776	4567	179.8	5022	197.7	934	1574	829	1397
	7.2	9.4	3200	126.0	3500	7716	4600	181.1	5100	200.8	550	927	470	792
	9.0	11.8	3400	133.9	3900	8598	4650	183.1	5150	202.8	410	691	350	590
962H	5.1	6.7	3000	118.1	2662	5869	4543	178.9	5147	202.6	995	1677	715	1205
	7.2	9.4	3200	126.0	3444	7593	4625	182.1	5247	206.6	635	1070	434	732
	9.0	11.8	3400	133.9	3847	8481	4496	177.0	5126	201.8	472	796	313	528
962K	5.1	6.7	3000	118.1	2620	5776	4567	179.8	5022	197.7	934	1574	829	1397
	7.2	9.4	3200	126.0	3500	7716	4800	189.0	5100	200.8	600	1011	643	1084
	9.0	11.8	3400	133.9	3900	8598	4850	190.9	5150	202.8	450	758	480	809
966H	6.7	8.8	3200	126.0	3598	7932	4909	193.3	5677	223.5	940	1584	975	1643
	11.5	15.0	3600	141.7	5021	11,069	4950	194.9	5500	216.5	444	748	450	758
966K	6.7	8.8	3200	126.0	3598	7932	4909	193.3	5677	223.5	964	1625	988	1665
	11.5	15.0	3600	141.7	5021	11,069	4950	194.9	5500	216.5	429	723	427	720
972H	6.7	8.8	3200	126.0	3598	7932	5003	197.0	5677	223.5	1076	1814	984	1659
	11.5	15.0	3600	141.7	5021	11,069	5170	203.5	5500	216.5	496	836	435	733
972K	6.7	8.8	3200	126.0	3598	7932	4909	193.3	5677	223.5	964	1625	988	1665
	11.5	15.0	3600	141.7	5021	11,069	5170	203.5	5500	216.5	503	848	446	752

Model	Interface	Bucket Type	Width Range		Capacity Range		Weight Range		GET
			mm	in	m <sup>3</sup>	yd <sup>3</sup>	kg	lb	
<b>926M</b> <b>924K</b>	Fusion	General Purpose	2550-2750	<b>100-108</b>	1.9-2.9	<b>2.5-3.8</b>	775-1042	<b>1705-2292</b>	J250/BOCE
		Light Material	2750	<b>108</b>	3.1-5.0	<b>4.0-6.5</b>	1075-1357	<b>2370-2992</b>	BOCE
		Side Dump	3105	<b>122</b>	1.9	<b>2.5</b>	1653	<b>3644</b>	BOCE
		High Dump	2550-3060	<b>100-120</b>	3.0-4.1	<b>3.9-5.4</b>	1710-2041	<b>3770-4500</b>	BOCE
		Grapple	2697	<b>106</b>	2.7-2.9	<b>3.5-3.8</b>	1632-1673	<b>3598-3688</b>	J250/BOCE
		Waste	3059	<b>120</b>	3.6-4.0	<b>4.7-5.2</b>	1416-1547	<b>3122-3410</b>	BOCE
		Woodchip	3330	<b>131</b>	4.9-5.5	<b>6.4-7.2</b>	1717-1795	<b>3785-3957</b>	BOCE
		Grading	2700	<b>106</b>	1.9	<b>2.5</b>	1233	<b>2716</b>	BOCE
		Sand & Gravel	2750	<b>108</b>	2.5-3.2	<b>3.2-4.1</b>	1011-1127	<b>2228-2485</b>	J250/BOCE
	ISO	General Purpose	2550-2750	<b>100-108</b>	2.1-2.9	<b>2.7-3.8</b>	775-997	<b>1705-2193</b>	J250/BOCE
		High Dump	2528-3032	<b>100-120</b>	3.0-4.1	<b>3.9-5.4</b>	1669-2088	<b>3680-4594</b>	BOCE
	Pin On	General Purpose	2550	<b>100</b>	1.7-2.5	<b>2.2-3.2</b>	775-977	<b>1708-2154</b>	J250/BOCE
		Light Material	2750	<b>108</b>	3.0-5.0	<b>3.9-6.5</b>	1094-1380	<b>2412-3042</b>	BOCE
		High Dump	2550-3060	<b>100-120</b>	3.0-4.1	<b>4.0-5.4</b>	1742-2067	<b>3840-4557</b>	BOCE
		Sand & Gravel	2750	<b>108</b>	2.5-3.2	<b>3.2-4.2</b>	1026-1279	<b>2262-2820</b>	J250/BOCE
<b>930M</b> <b>930K</b>	Fusion	General Purpose	2550-2750	<b>100-108</b>	2.1-2.9	<b>2.6-3.8</b>	825-1042	<b>1819-2292</b>	J250/BOCE
		Light Material	2750	<b>108</b>	3.1-5.0	<b>4.0-6.5</b>	1075-1357	<b>2370-2992</b>	BOCE
		Side Dump	3105	<b>122</b>	1.9	<b>2.5</b>	1653	<b>3644</b>	BOCE
		High Dump	2550-3060	<b>100-120</b>	3.0-5.0	<b>3.9-6.5</b>	1710-2123	<b>3770-4680</b>	BOCE
		Grapple	2697	<b>106</b>	2.7-2.9	<b>3.5-3.8</b>	1632-1673	<b>3598-3688</b>	J250/BOCE
		Waste	3059	<b>120</b>	3.6-4.0	<b>4.7-5.2</b>	1416-1547	<b>3122-3410</b>	BOCE
		Woodchip	3330	<b>131</b>	4.9-5.5	<b>6.4-7.2</b>	1717-1795	<b>3785-3957</b>	BOCE
		Grading	2700	<b>106</b>	1.9	<b>2.5</b>	1233	<b>2716</b>	BOCE
		Sand & Gravel	2750	<b>108</b>	2.5-2.9	<b>3.2-3.8</b>	1011-1127	<b>2228-2485</b>	J250/BOCE
	ISO	General Purpose	2550-2750	<b>100-108</b>	2.1-2.9	<b>2.7-3.8</b>	775-997	<b>1705-2193</b>	J250/BOCE
		High Dump	2528-3032	<b>100-120</b>	3.0-5.0	<b>3.9-6.5</b>	1669-2187	<b>3680-4833</b>	BOCE
	Pin On	General Purpose	2550	<b>100</b>	1.7-2.5	<b>2.2-3.2</b>	775-977	<b>1708-2154</b>	J250/BOCE
		Light Material	2750	<b>108</b>	3.0-5.0	<b>3.9-6.5</b>	1094-1380	<b>2412-3042</b>	BOCE
		High Dump	2550-3060	<b>100-120</b>	3.0-5.0	<b>4.0-6.5</b>	1695-2149	<b>3737-4738</b>	BOCE
		Sand & Gravel	2750	<b>108</b>	2.5-3.2	<b>3.2-4.2</b>	1026-1279	<b>2262-2820</b>	J250/BOCE
<b>938K</b> <b>938M</b>	Fusion	General Purpose	2550-2750	<b>100-108</b>	1.9-2.9	<b>2.5-3.8</b>	775-1042	<b>1705-2292</b>	J250/BOCE
		Light Material	2750	<b>108</b>	3.1-5.0	<b>4.0-6.5</b>	1075-1360	<b>2370-2992</b>	BOCE
		Side Dump	3105	<b>122</b>	1.9	<b>2.5</b>	1653	<b>3644</b>	BOCE
		High Dump	2550-3060	<b>100-120</b>	3.0-5.0	<b>3.9-6.5</b>	1710-2123	<b>3770-4680</b>	BOCE
		Grapple	2697	<b>106</b>	2.7-2.9	<b>3.5-3.8</b>	1632-1673	<b>3598-3688</b>	J250/BOCE
		Waste	3059	<b>120</b>	3.6-4.0	<b>4.7-5.2</b>	1416-1547	<b>3122-3410</b>	BOCE
		Woodchip	3330	<b>131</b>	4.9-5.5	<b>6.4-7.2</b>	1717-1795	<b>3785-3957</b>	BOCE
		Grading	2700	<b>106</b>	1.9	<b>2.5</b>	1233	<b>2716</b>	BOCE
		Sand & Gravel	2750	<b>108</b>	2.7-3.2	<b>3.4-4.2</b>	1011-1127	<b>2228-2485</b>	J250/BOCE
	ISO	General Purpose	2550-2750	<b>100-108</b>	2.1-2.9	<b>2.7-3.8</b>	775-997	<b>1705-2193</b>	J250/BOCE
		High Dump	2528-3032	<b>100-120</b>	3.0-5.0	<b>3.9-6.5</b>	1669-2187	<b>3680-4833</b>	BOCE
	Pin On	General Purpose	2550-2750	<b>100-108</b>	2.5-2.9	<b>3.2-3.8</b>	968-1059	<b>2134-2330</b>	J250/BOCE
		Light Material	2750	<b>108</b>	3.5-5.0	<b>4.5-6.5</b>	1178-1378	<b>2596-3038</b>	BOCE
		High Dump	3060	<b>120</b>	4.1-5.0	<b>5.4-6.5</b>	2065-2147	<b>4553-4733</b>	BOCE
		Sand & Gravel	2750	<b>108</b>	2.7-3.2	<b>3.5-4.2</b>	1108-1279	<b>2443-2820</b>	J250/BOCE

Model	Interface	Bucket Type	Width		Capacity		Weight		GET
			mm	in	m <sup>3</sup>	yd <sup>3</sup>	kg	lb	
IT62G	HPL	Material Handling	2921	115	3.1	4.1	1242	2738	K80X8
		Material Handling	2921	115	3.2	4.2	1259	2776	K80X8
		Woodchip	3277	129	5.5	7.2	1493	3291	N/A
950H, 950G, 962H, 926G	Pin On	General Purpose Performance Series	2894	114	3.1	4.1	1507	3322	K80X8
		General Purpose Performance Series	2894	114	3.3	4.3	1550	3417	K80X8
		Material Handling Performance Series	2894	114	3.2	4.2	1538	3391	K80X8
		Material Handling Performance Series	2894	114	3.4	4.4	719	1585	K80X8
		Material Handling Performance Series	2894	114	3.8	5.0	1684	3713	K80X8
		General Purpose	2921	115	3.1	4.0	1483	3269	K80X8
		General Purpose	2921	115	3.4	4.5	1583	3490	K80X8
		Material Handling	2921	115	3.4	4.5	1424	3139	K80X8
		Material Handling	2946	116	4.2	5.5	1725	3803	K80X8
		Material Handling	N/A	N/A	3.3	4.3	1326	2923	K80X8
		Rock	2972	117	2.9	3.8	1550	3417	N/A
	Rock	2972	117	2.9	3.8	1618	3567	N/A	
	Woodchip	3327	131	9.2	12.0	2279	5024	N/A	
	HPL	General Purpose	2921	115	3.1	4.1	1479	3261	K80X8
		General Purpose	2921	115	3.2	4.2	1280	2822	K80X8
		General Purpose	2921	115	3.4	4.4	1385	3053	K80X8
		Woodchip	3327	131	9.2	12.0	2349	5179	N/A
	Fusion	General Purpose	2896	114	3.1	4.1	1322	2915	K80X8
		General Purpose	2896	114	3.4	4.4	1408	3104	K80X8
		General Purpose	2896	114	3.8	5.0	1483	3269	K80X8
		Rock	2969	117	3.1	4.1	1588	3501	K90X8
Rock		2969	117	3.3	4.3	1638	3611	K90X8	
Material Handling		2896	114	3.4	4.4	1370	3020	K80X8	
Material Handling		2896	114	3.8	5.0	1447	3190	K80X8	
Coal		3302	130	5.9	7.7	1928	4251	N/A	
Multi-purpose		2946	116	2.87	3.75	2087	4601	N/A	
Side Dump		3226	127	2.87	3.75	2340	5159	N/A	
High Dump		2921	115	4.6	6.0	2657	5858	N/A	
Grapple		2921	115	3.25	4.25	2139	4716	N/A	
Waste		3048	120	5.2	6.8	2163	4769	N/A	
Woodchip	3327	131	9.2	12.0	2121	4676	N/A		

N/A = Not Applicable



Model	Interface	Bucket Type	Width		Capacity		Weight		GET	
			mm	in	m <sup>3</sup>	yd <sup>3</sup>	kg	lb		
<b>966, 972</b>	Pin On	General Purpose Performance Series	3193	126	4.0	5.2	2164	4771	K90X8	
		General Purpose Performance Series	3193	126	4.2	5.5	2220	4894	K90X8	
		General Purpose Performance Series	3193	126	4.6	6.0	2220	4894	K90X8	
		General Purpose Performance Series	3193	126	4.6	6.0	2303	5077	K90X8	
		General Purpose Performance Series	3201	126	5.0	6.5	2332	5141	K90X8	
		Material Handling Performance Series	3302	130	4.0	5.2	2173	4791	K90X8	
		Material Handling Performance Series	3193	126	4.2	5.5	2108	4647	K90X8	
		Material Handling Performance Series	3193	126	4.6	6.0	2152	4744	K90X8	
		Rock Performance Series	3255	128	3.4	4.4	2362	5207	K90X8	
		Rock Performance Series	3255	128	4.0	5.2	2397	5284	K90X8	
		General Purpose	3150	124	4.0	5.2	1992	4392	K90X8	
		General Purpose	3226	127	5.2	6.8	2141	4720	N/A	
		Material Handling	3302	130	4.0	5.2	2049	4517	K90	
		Material Handling	3311	130	4.7	6.1	2207	4866	K90	
		Material Handling	3200	126	4.9	6.4	2130	4696	N/A	
		Material Handling	3193	126	4.3	5.6	2108	4647	N/A	
		Rock	3252	128	N/A	N/A	2405	5302	K90X8	
		Rock	3252	128	N/A	N/A	2522	5560	J350X8	
		Rock	3252	128	N/A	N/A	2522	5560	K90X8	
		Heavy Duty Rock	3251	128	3.6	4.7	2425	5346	J350	
		Heavy Duty Rock	3252	128	3.6	4.7	2562	5648	K90	
		Heavy Duty Rock	3251	128	4.0	5.2	2949	6501	K90	
		Woodchip	3327	131	8.0	10.46	2474	5454	N/A	
		Woodchip	3937	155	9.9	13.0	2359	5201	N/A	
		Woodchip	3923	154	10.2	13.3	2279	5024	N/A	
		HPL	General Purpose	3023	119	3.8	5.0	1093	2410	K90X8
			General Purpose	3226	127	4.2	5.5	1986	4378	K90X8
			General Purpose	3226	127	4.6	6.0	1900	4189	K90X8
			Woodchip	3328	131	8.0	10.46	2360	5203	N/A
			Woodchip	3937	155	9.9	13.0	2825	6228	N/A

N/A = Not Applicable

Model	Interface	Bucket Type	Width		Capacity		Weight		GET
			mm	in	m <sup>3</sup>	yd <sup>3</sup>	kg	lb	
966, 972	Fusion	General Purpose	3307	130	3.8	5.0	1730	3814	K90X8
		General Purpose	3307	130	4.2	5.5	1808	3986	K90X8
		General Purpose	3311	130	4.8	6.3	1914	4220	K90X8
		Rock/Spade	3252	128	N/A	N/A	2174	4793	K90X8
		Rock/Spade	3252	128	N/A	N/A	2050	4519	K90X8
		Material Handling	3311	130	4.2	5.5	1850	4079	K90X8
		Material Handling	3311	130	4.6	6.0	1882	4149	K90X8
		Coal	3405	134	6.7	8.8	2271	5007	K90X8
		Coal	3405	134	7.7	10.1	2454	5410	K90X8
		Multi-purpose	3220	127	N/A	N/A	2785	6140	N/A
		Side Dump	3677	145	N/A	N/A	2832	6243	N/A
		High Dump	3059	120	N/A	N/A	2862	6310	N/A
		Grapple	3048	120	N/A	N/A	4380	9656	N/A
		Waste	3323	131	N/A	N/A	2569	5664	N/A
Woodchip	3923	154	9.94	13	2543	5606	N/A		
980H, 980G	Pin On	General Purpose Performance Series	3405	134	5.3	6.9	2572	5670	K100X8
		General Purpose Performance Series	3405	134	5.7	7.5	2677	5902	K100X8
		General Purpose Performance Series	3405	134	7.0	9.2	2726	6010	K100X8
		Material Handling Performance Series	3405	134	5.7	7.5	2780	6129	K100X8
		Rock Performance Series	3510	138	N/A	N/A	3402	7500	K100X8
		Rock Performance Series	3510	138	N/A	N/A	3531	7785	K100X8
		General Purpose	3531	139	4.8	6.3	2340	5159	K100X8
		General Purpose	3531	139	5.2	6.8	2430	5357	K100X8
		General Purpose	3531	139	5.5	7.2	2503	5518	K100X8
		General Purpose	3413	134	N/A	N/A	2580	5688	K100X8
		General Purpose	3531	139	5.2	6.8	2398	5287	K100X8
		General Purpose	3531	139	5.5	7.2	2654	5851	K100X8
		General Purpose-HD	3533	139	5.5	7.2	3167	6982	K100X8
		Material Handling	3531	139	5.7	7.5	2727	6012	K100X8
		Material Handling	3683	145	7.5	9.7	3512	7743	K100X8
		Rock	3480	137	N/A	N/A	2576	5679	J400X8
		Rock	3492	137	N/A	N/A	2754	6072	K100X8
		Rock	3492	137	N/A	N/A	3084	6799	J400X8
		Rock	3492	137	N/A	N/A	3132	6905	K100X8
		Coal	3638	143	N/A	N/A	3622	7985	N/A
	Woodchip	4165	164	N/A	N/A	3996	8810	N/A	
	Pin On	Coal	3800	150	6.5	8.5	4511	9945	K110
		Coal	4120	162	11.5	15.0	5910	13,029	BOCE Included
		Coal	4120	162	13.0	17.0	6325	13,944	BOCE Included
General Purpose		2695	106	7.0	9.2	4218	9299	K110	
General Purpose		3900	154	7.7	10.1	4770	10,516	BOCE Included	
Rock		3835	151	6.4	8.4	4815	10,615	K130	
Rock		4026	159	6.9	9.0	4662	10,278	K110	
Rock		4026	159	7.7	10.1	4600	10,141	K110	

N/A = Not Applicable

Model	Interface	Bucket Type	Width		Capacity		Weight		GET
			mm	in	m <sup>3</sup>	yd <sup>3</sup>	kg	lb	
990K	Pin On	Rock	4450	175	8.5	11.1	6772	14,930	K130
		Rock	4597	181	9.2	12.0	7038	15,516	K130
		Heavy Duty Rock	4510	178	8.5	11.1	8594	18,947	K130 MAWPs
		Heavy Duty Granite	4620	182	8.5	11.1	9929	21,890	K150 MAWPs
		Slag	4450	175	9.2	12.0	9613	21,193	Serrated
		Slag	4500	177	8.5	11.1	9149	20,170	K130
		Coal	4370	172	13.4	17.5	7460	16,446	BOCE Included
		Slag	4450	175	7.0	9.2	8525	18,794	K150
		Serrated Edge Rock	4610	181	9.5	12.4	8140	17,946	N/A
992K	Pin On	Rock	4824	190	10.7	14.0	9382	20,684	K150
		Rock	4884	192	11.5	15.0	9776	21,552	K170
		Rock	4824	190	11.5	15.0	9557	21,070	K150
		Rock	4824	190	12.2	16.0	10 574	23,312	K170
		Heavy Duty Rock	5068	200	10.7	14.0	11 560	25,485	K170
		High Abrasion Rock	5068	200	10.7	14.0	11 927	26,295	K150
		Heavy Duty Granite	5165	203	10.7	14.0	13 720	30,247	K150
		Coal	6170	243	19.0	24.9	12 504	27,567	BOCE Included
		Iron Ore	4900	193	9.0	11.8	11 172	24,630	K150
Serrated Edge Rock	4824	190	12.3	16.1	10 282	22,668	N/A		
993K	Pin On	Rock	5068	200	12.2	16.0	12 864	28,360	K170
		Rock	5068	200	13.0	17.0	13 380	29,498	K170
		Rock	5068	200	13.8	18.0	14 024	30,918	K170
		Rock	5068	200	14.5	19.0	14 209	31,325	K170
		High Abrasion Rock	5160	203	12.2	16.0	15 205	33,521	K170
		High Abrasion Rock	5160	203	13.0	17.0	15 456	34,075	K170
		Heavy Duty Granite	5160	203	13.0	17.0	17 418	38,400	K170
		Coal	6300	248	23.0	30.1	17 673	38,962	K170
		Iron Ore	5160	203	10.0	13.1	14 063	31,004	K170
Serrated Edge Rock	5080	200	15.0	19.6	13 915	30,677	N/A		
994K	Pin On	Rock	6223	245	19.1-24.5	25-32	19 205- 21 293	42,340- 46,942	Spade edge*
		Heavy Duty Rock	6240	246	19.1-21.4	25-28	20 699- 21 303	45,633- 46,966	Spade edge*
		Coal	6964	274	32.1-39.8	42-52	20 862- 22 773	45,992- 50,206	Straight edge*
		Iron Ore	6240	246	17.2	22.5	19 518	43,029	Spade edge*

\*With teeth and segments.  
N/A = Not Applicable

Model	Interface	Bucket Type	Width		Capacity		Weight		GET	
			mm	in	m <sup>3</sup>	yd <sup>3</sup>	kg	lb		
IT62G	HPL	Material Handling	2921	115	3.20	4.2	1259	571	K80X8	
		Woodchip	3277	129	8.40	11.0	1493	677	N/A	
950H, 950G, 962H, 962G	Pin On	General Purpose	2894	114	3.10	4.1	1507	684	K80X8	
		General Purpose	2894	114	3.30	4.3	1550	703	K80X8	
		Material Handling	2894	114	3.20	4.2	1538	698	K80X8	
		Material Handling	2894	114	3.40	4.4	1584	719	K80X8	
		Material Handling	2894	114	3.80	5.0	1684	764	K80X8	
		General Purpose	2997	118	2.70	3.5	1347	611	K80X8	
		General Purpose	2921	115	3.06	4.0	1483	673	K80X8	
		Material Handling	2946	116	5.73	7.5	1878	852	N/A	
		Material Handling	2946	116	4.40	5.8	1905	864	N/A	
		Material Handling	N/A	N/A	3.30	4.3	1326	601	K80X8	
		Waste Handling	3058	120	5.20	6.8	2375	1077	N/A	
		HPL	Woodchip	3327	131	9.20	12.0	2349	1066	N/A
		966, 972	Pin On	General Purpose	3193	126	4.00	5.2	2164	982
General Purpose	3193			126	4.20	5.5	2220	1007	K90X8	
General Purpose	3193			126	4.60	6.0	2220	1007	K90X8	
General Purpose	3193			126	4.60	6.0	2303	1045	K90X8	
General Purpose	3201			126	5.00	6.5	2332	1058	K90X8	
Material Handling	3302			130	4.00	5.2	2173	986	K90X8	
Material Handling	3193			126	4.20	5.5	2108	956	K90X8	
Material Handling	3193			126	4.60	6.0	2152	976	K90X8	
Rock	3255			128	3.40	4.4	2362	1071	K90X8	
Rock	3255			128	4.00	5.2	2397	1087	K90X8	
General Purpose	3150			124	3.80	5.0	2188	992	K90X8	
General Purpose	3150			124	3.60	4.7	1903	863	K90X8	
General Purpose	3150			124	4.00	5.2	1992	904	K90X8	
Material Handling	3454			136	5.73	7.5	2586	1173	N/A	
Material Handling	3429			135	7.26	9.5	2595	1177	N/A	
Rock	3252			128	N/A	N/A	2405	1091	K90X8	
Woodchip	3937			155	9.90	12.9	2359	1070	N/A	
HPL	General Purpose			3023	119	3.82	5.0	1093	496	K90X8
	General Purpose			3226	127	4.21	5.5	1986	901	K90X8
980H, 980G	Pin On	General Purpose	3405	134	5.30	6.9	2572	1167	K100X8	
		General Purpose	3405	134	5.70	7.5	2677	1214	K100X8	
		General Purpose	3405	134	7.00	9.2	2726	1237	K100X8	
		Material Handling	3405	134	5.70	7.5	2780	1261	K100X8	
		Rock	3510	138	N/A	N/A	3402	1543	K100X8	
		Rock	3510	138	N/A	N/A	3531	1602	K100X8	
		General Purpose	3531	139	5.40	7.1	2430	1102	K100X8	
		General Purpose	3531	139	5.70	7.5	2503	1135	K100X8	
		Rock	3492	137	N/A	N/A	3084	1399	J400X8	
		Coal	3638	143	N/A	N/A	3622	1643	N/A	
		HPL	General Purpose	3454	136	5.00	6.5	2794	1267	K100X8
BH	Block Handler	3658	144	4.50	5.9	3810	1728	K100X8		

N/A = Not Applicable

Model	Interface	Bucket Type	Width		Capacity		Weight		GET
			mm	in	m <sup>3</sup>	yd <sup>3</sup>	kg	lb	
988K	Pin On	General Purpose Performance Series	3855	152	6.9-8.4	9.0-11.0	4539-4994	10,007-11,010	K110
		Rock Performance Series	4020	158	6.4-7.7	8.3-10.0	4880-5263	10,759-11,603	K130
		Heavy Duty Rock Performance Series	4080	161	6.4	8.3	6360	14,021	K130
		Heavy Duty Granite Performance Series	3986	157	6.4	8.3	7433	16,385	K130
		Serrated Edge Rock	3968	156	6.4-6.9	8.3-9.0	5455-5634	12,026-12,421	N/A
		Iron Ore	3922	154	4.7	6.2	5771	12,723	K130
		Coal	4120	162	11.5-13.0	15.0-17.0	6023-6435	13,728-14,186	BOCE Included
		Slag	3900-4032	154-159	5.4-6.4	7.0-8.3	7633-8454	16,828-18,638	J600/Serrated Edge
990K	Pin On	Rock	4450	175	8.50	11.1	6772	3072	K130
		Rock	4597	181	9.20	12.0	7038	3192	K130
		Heavy Duty Granite	4620	182	8.50	11.1	9929	4504	K150 MAWPs
		Slag	4450	175	9.20	12.0	9613	4360	Serrated Weld-On Edge
		Slag	4500	177	8.50	11.1	9149	4150	K130
992K	Pin On	Rock	4824	190	10.70	14.0	9382	4256	K150
		Rock	4884	192	11.50	15.0	9776	4434	K170
		Rock	4824	190	11.50	15.0	9557	4335	K150
		Rock	4824	190	12.20	16.0	10 574	4796	K170
		Heavy Duty Rock	5068	200	10.70	14.0	11 560	5244	K170
		High Abrasion Rock	5068	200	10.70	14.0	11 927	5410	K150
		Heavy Duty Granite	5165	203	10.70	14.0	13 720	6223	K150
		Serrated Edge Rock	4824	190	12.30	16.1	10 282	4664	N/A
993K	Pin On	Rock	5068	200	12.20	16.0	12 864	5835	K170
		Rock	5068	200	14.50	19.0	14 209	6445	K170
		High Abrasion Rock	5160	203	13.00	17.0	15 456	7011	K170
		Heavy Duty Granite	5160	203	13.00	17.0	17 418	7901	K170
		Coal	6300	248	23.00	30.1	17 673	8016	K170
		Iron Ore	5160	203	10.00	13.1	14 063	6379	K170
994K	Pin On	Rock	6223	245	19.1-24.5	25-32	19 205-21 293	42,340-46,942	Spade edge*
		Heavy Duty Rock	6240	246	19.1-21.4	25-28	20 699-21 303	45,633-46,966	Spade edge*
		Coal	6964	274	32.1-39.8	42-52	20 862-22 773	45,992-50,206	Straight edge*
		Iron Ore	6240	246	17.2	22.5	19 518	43,029	Spade edge*

\*With teeth and segments.  
N/A = Not Applicable

Model	Interface	Bucket Type	Width		Capacity		Weight		GET
			mm	in	m <sup>3</sup>	yd <sup>3</sup>	kg	lb	
IT62G	IT	Woodchip	3277	129	8.40	10.99	1493	3291	N/A
950H, 950G, 962H, 962G	Pin On	General Purpose Performance Series	2894	114	3.10	4.05	1507	3322	K80X8
		General Purpose Performance Series	2894	114	3.30	4.32	1550	3417	K80X8
		Material Handling Performance Series	2894	114	3.20	4.19	1538	3391	K80X8
		Material Handling Performance Series	2894	114	3.40	4.45	1584	3492	K80X8
		Material Handling Performance Series	2894	114	3.80	4.97	1684	3713	K80X8
		General Purpose	2997	118	2.70	3.53	1347	2970	K80X8
		General Purpose	2921	115	3.06	4.00	1483	3269	K80X8
		Material Handling	2946	116	5.73	7.49	1878	4140	N/A
		Material Handling	2946	116	4.40	5.75	1905	4200	N/A
		Material Handling	N/A		3.30	4.32	1326	2923	K80X8
		Waste Handling	3058	120	5.20	6.80	2375	5236	N/A
		Rock	2972	117	2.90	3.79	1826	4026	J350X8
		966G, 972G		General Purpose Performance Series	3193	126	4.00	5.23	2164
General Purpose Performance Series	3193			126	4.20	5.49	2220	4894	K90X8
General Purpose Performance Series	3193			126	4.60	6.02	2220	4894	K90X8
General Purpose Performance Series	3193			126	4.60	6.02	2303	5077	K90X8
General Purpose Performance Series	3201			126	5.00	6.54	2332	5141	K90X8
Material Handling Performance Series	3302			130	4.00	5.23	2173	4791	K90X8
Material Handling Performance Series	3193			126	4.20	5.49	2108	4647	K90X8
Material Handling Performance Series	3193			126	4.60	6.02	2152	4744	K90X8
Rock Performance Series	3255			128	3.40	4.45	2362	5207	K90X8
Rock Performance Series	3255			128	4.00	5.23	2397	5284	K90X8
General Purpose	3193			126	4.96	6.49	2125	4685	K90X8
General Purpose	3150			124	3.60	4.71	1903	4195	K90X8
General Purpose	3150			124	4.00	5.23	1992	4392	K90X8
Material Handling	3302			130	4.00	5.23	2049	4517	K90X8
Material Handling	3311			130	4.70	6.15	2207	4866	K90X8
Material Handling	3447			136	5.73	7.49	2426	5348	N/A
Rock	3252			128	—	—	2405	5302	K90X8
Side Dump	3299			130	3.40	4.45	3855	8499	K80X8

N/A = Not Applicable

Model	Interface	Bucket Type	Width		Capacity		Weight Range		GET
			mm	in	m <sup>3</sup>	yd <sup>3</sup>	kg	lb	
<b>980H, 980G</b>	Pin On	General Purpose Performance Series	3405	<b>134</b>	5.30	<b>6.93</b>	2572	<b>5670</b>	K100X8
		General Purpose Performance Series	3405	<b>134</b>	5.70	<b>7.46</b>	2677	<b>5902</b>	K100X8
		General Purpose Performance Series	3405	<b>134</b>	7.00	<b>9.16</b>	2726	<b>6010</b>	K100X8
		Material Handling Performance Series	3405	<b>134</b>	5.70	<b>7.46</b>	2780	<b>6129</b>	K100X8
		Rock Performance Series	3510	<b>138</b>	5.40	<b>7.10</b>	3402	<b>7500</b>	K100X8
		Rock Performance Series	3510	<b>138</b>	5.40	<b>7.10</b>	3531	<b>7785</b>	K100X8
		General Purpose	3531	<b>139</b>	5.40	<b>7.06</b>	2430	<b>5357</b>	K100X8
	HPL	Block Handler	3658	<b>144</b>	4.50	<b>5.89</b>	3810	<b>8400</b>	K100X8
<b>986H</b>	Pin On	Rock	3772	<b>148.5</b>	5.4-6.1	<b>7-8</b>	3692-3907	<b>8139-8693</b>	J460
<b>988K</b>	Pin On	General Purpose Performance Series	3855	<b>152</b>	6.9-8.4	<b>9.0-11.0</b>	4539-4994	<b>10,007-11,010</b>	K110
		Rock Performance Series	4020	<b>158</b>	6.4-7.7	<b>8.3-10.0</b>	4880-5263	<b>10,759-11,603</b>	K130
		Heavy Duty Rock Performance Series	4080	<b>161</b>	6.4	<b>8.3</b>	6360	<b>14,021</b>	K130
		Heavy Duty Granite Performance Series	3986	<b>157</b>	6.4	<b>8.3</b>	7433	<b>16,385</b>	K130
		Serrated Edge Rock	3968	<b>156</b>	6.4-6.9	<b>8.3-9.0</b>	5455-5634	<b>12,026-12,421</b>	N/A
		Iron Ore	3922	<b>154</b>	4.7	<b>6.2</b>	5771	<b>12,723</b>	K130
		Coal	4120	<b>162</b>	11.5-13.0	<b>15.0-17.0</b>	6023-6435	<b>13,728-14,186</b>	BOCE Included
		Slag	3900-4032	<b>154-159</b>	5.4-6.4	<b>7.0-8.3</b>	7633-8454	<b>16,828-18,638</b>	J600/Serrated Edge

N/A = Not Applicable

Model	Interface	Bucket Type	Width		Capacity		Weight Range		GET
			mm	in	m <sup>3</sup>	yd <sup>3</sup>	kg	lb	
990K	Pin On	Rock	4450	175	8.50	11.12	6772	14,930	K130 K130 K130 MAWPs K150 MAWPs Serrated Weld-On Edge K130
		Rock	4597	181	9.20	12.03	7038	15,516	
		Heavy Duty Rock	4510	178	8.50	11.12	8594	18,947	
		Heavy Duty Granite	4620	182	8.50	11.12	9929	21,890	
		Slag	4450	175	9.20	12.03	9613	21,193	
		Slag	4500	177	8.50	11.12	9149	20,170	
992K	Pin On	Rock	4824	190	10.70	14.00	9382	20,684	K150
		Rock	4884	192	11.50	15.04	9776	21,552	K170
		Rock	4824	190	11.50	15.04	9557	21,070	K150
		Rock	4824	190	12.20	15.96	10 574	23,312	K170
		Heavy Duty Rock	5068	200	10.70	14.00	11 560	25,485	K170
		High Abrasion Rock	5068	200	10.70	14.00	11 927	26,295	K150
		Heavy Duty Granite	5165	203	10.70	14.00	13 720	30,247	K150
		Serrated Edge Rock	4824	190	12.30	16.09	10 282	22,668	N/A
993K	Pin On	Rock	5068	200	12.20	15.96	12 864	28,360	K170
		Rock	5068	200	14.50	18.97	14 209	31,325	K170
		High Abrasion Rock	5160	203	13.00	17.00	15 456	34,075	K170
		Heavy Duty Granite	5160	203	13.00	17.00	17 418	38,400	K170
		Coal	6300	248	23.00	30.08	17 673	38,962	K170
		Iron Ore	5160	203	10.00	13.08	14 063	31,004	K170
994K	Pin On	Rock	6223	245	19.1-24.5	25-32	19 205- 21 293	42,340- 46,942	Spade edge*
		Heavy Duty Rock	6240	246	19.1-21.4	25-28	20 699- 21 303	45,633- 46,966	Spade edge*
		Coal	6964	274	32.1-39.8	42-52	20 862- 22 773	45,992- 50,206	Straight edge*
		Iron Ore	6240	246	17.2	22.5	19 518	43,029	Spade edge*

\*With teeth and segments.  
N/A = Not Applicable



**906K/M  
Vertical Coupler**

Bucket Type	Rated Capacity		Maximum Material Density	
	m <sup>3</sup>	yd <sup>3</sup>	kg/m <sup>3</sup>	lb/yd <sup>3</sup>
General Purpose	0.90	<b>1.18</b>	1755	<b>2952</b>
Light Material	1.20	<b>1.57</b>	1208	<b>2032</b>
Multi-Purpose	0.75	<b>0.98</b>	2131	<b>3584</b>

**906K/M  
Horizontal Coupler**

Bucket Type	Rated Capacity		Maximum Material Density	
	m <sup>3</sup>	yd <sup>3</sup>	kg/m <sup>3</sup>	lb/yd <sup>3</sup>
General Purpose	0.90	<b>1.18</b>	1889	<b>3177</b>
Light Material	1.20	<b>1.57</b>	1271	<b>2138</b>
Multi-Purpose	0.75	<b>0.98</b>	2184	<b>3674</b>

**907K/M  
Vertical Coupler**

Bucket Type	Rated Capacity		Maximum Material Density	
	m <sup>3</sup>	yd <sup>3</sup>	kg/m <sup>3</sup>	lb/yd <sup>3</sup>
General Purpose	1.00	<b>1.31</b>	1584	<b>2664</b>
Light Material	1.20	<b>1.57</b>	1218	<b>2049</b>
Multi-Purpose	0.75	<b>0.98</b>	2149	<b>3615</b>

**907K/M  
Horizontal Coupler**

Bucket Type	Rated Capacity		Maximum Material Density	
	m <sup>3</sup>	yd <sup>3</sup>	kg/m <sup>3</sup>	lb/yd <sup>3</sup>
General Purpose	1.00	<b>1.31</b>	1706	<b>2870</b>
Light Material	1.20	<b>1.57</b>	1310	<b>2203</b>
Multi-Purpose	0.75	<b>0.98</b>	2202	<b>3704</b>

**908K/M  
Vertical Coupler**

Bucket Type	Rated Capacity		Maximum Material Density	
	m <sup>3</sup>	yd <sup>3</sup>	kg/m <sup>3</sup>	lb/yd <sup>3</sup>
General Purpose	1.10	<b>1.44</b>	1549	<b>2605</b>
Light Material	1.50	<b>1.96</b>	1034	<b>1739</b>
Multi-Purpose	0.90	<b>1.18</b>	1929	<b>3245</b>

**908K/M  
Horizontal Coupler**

Bucket Type	Rated Capacity		Maximum Material Density	
	m <sup>3</sup>	yd <sup>3</sup>	kg/m <sup>3</sup>	lb/yd <sup>3</sup>
General Purpose	1.10	<b>1.44</b>	1658	<b>2789</b>
Light Material	1.50	<b>1.96</b>	1106	<b>1860</b>
Multi-Purpose	0.90	<b>1.18</b>	1967	<b>3309</b>

910K — Standard Lift

Bucket Fill Factor		kg/m <sup>3</sup>	1000	1050	1100	1150	1200	1250	1450	1500	1550	1600	1650	1700	1750	
		lb/yd <sup>3</sup>	1685	1769	1854	1938	2022	2106	2443	2528	2612	2696	2780	2865	2949	
		m <sup>3</sup>	yd <sup>3</sup>													
General Purpose	Pin On	1.3	1.7								112%	109%	105%	102%	99%	
		1.4	1.8						111%	108%	104%	101%	98%	95%		
		1.6	2.1					111%	96%							
		1.8	2.4			111%	106%	102%	98%							
	1.9	2.5	115%	109%	104%	100%	96%									
	IT	1.3	1.7								114%	110%	107%	104%	101%	98%
		1.3	1.7							114%	111%	107%	104%	101%	98%	
		1.5	2.0						101%	98%	94%					
		1.6	2.1					114%	109%	94%						
		1.7	2.2				111%	106%	102%							
	1.9	2.5	110%	104%	100%	95%										
	ISO	1.3	1.7								111%	108%	104%	101%	98%	96%
1.5		2.0						114%	98%	95%						
1.7		2.2														
		1.9	2.5	107%	101%	97%										

23

Material density and fill factor are key variables when choosing the appropriate size of the bucket. The long floor and open throat design of the Performance Series Buckets along with the aggressive rack angles of the Cat Optimized Z-bar Loader will demonstrate fill factors greater than 100% ISO rated. Refer to the **Fill Factors** table for expected fill factor per material density and **Bucket Selection** table for bucket sizing.

910K — Standard Lift Fill Factors

Materials	Density	Fill %
Earth and rock	~ 1800 kg/m <sup>3</sup> ~ 3033 lb/yd <sup>3</sup>	~ 115%
Sand & gravel	~ 1700 kg/m <sup>3</sup> ~ 2865 lb/yd <sup>3</sup>	~ 115%
Aggregates	~ 1600 kg/m <sup>3</sup> ~ 2696 lb/yd <sup>3</sup>	~ 105%
Bulk grains	~ 750 kg/m <sup>3</sup> ~ 1264 lb/yd <sup>3</sup>	~ 100%
Woodchips	~ 500 kg/m <sup>3</sup> ~ 843 lb/yd <sup>3</sup>	~ 100%

**910K — High Lift**

Bucket Fill Factor		kg/m <sup>3</sup>	900	950	1000	1050	1100	1150	1250	1350	1450	1500	1550	1600	1650	
		lb/yd <sup>3</sup>	1517	1601	1685	1769	1854	1938	2106	2275	2443	2528	2612	2696	2780	
		m <sup>3</sup>														
		yd <sup>3</sup>														
General Purpose	Pin On	1.3	1.7									111%	108%	104%	101%	98%
		1.4	1.8							111%	103%	100%	97%			
		1.6	2.1					112%	103%	96%						
		1.8	2.4			114%	108%	103%	99%							
	1.9	2.5	113%	107%	102%	97%										
	IT	1.3	1.7									109%	106%	102%	99%	96%
		1.3	1.7							109%	106%	102%	99%	96%		
		1.5	2.0					108%	100%							
		1.6	2.1				115%	110%	101%							
		1.7	2.2			113%	107%	103%	95%							
	ISO	1.9	2.5	103%	97%											
		1.3	1.7									107%	104%	100%	97%	94%
		1.5	2.0					106%	98%							
		1.7	2.2			110%	105%	100%								
			1.9	2.5	100%	94%										

Material density and fill factor are key variables when choosing the appropriate size of the bucket. The long floor and open throat design of the Performance Series Buckets along with the aggressive rack angles of the Cat Optimized Z-bar Loader will demonstrate fill factors greater than 100% ISO rated. Refer to the **Fill Factors** table for expected fill factor per material density and **Bucket Selection** table for bucket sizing.

**910K — High Lift Fill Factors**

Materials	Density	Fill %
Earth and rock	~ 1800 kg/m <sup>3</sup> ~ 3033 lb/yd <sup>3</sup>	~ 115%
Sand & gravel	~ 1700 kg/m <sup>3</sup> ~ 2865 lb/yd <sup>3</sup>	~ 115%
Aggregates	~ 1600 kg/m <sup>3</sup> ~ 2696 lb/yd <sup>3</sup>	~ 105%
Bulk grains	~ 750 kg/m <sup>3</sup> ~ 1264 lb/yd <sup>3</sup>	~ 100%
Woodchips	~ 500 kg/m <sup>3</sup> ~ 843 lb/yd <sup>3</sup>	~ 100%

### 914K — Standard Lift

Bucket Fill Factor		kg/m <sup>3</sup>	900	1000	1100	1200	1300	1400	1500	1600	1700	1800	1900	2000	2100	
		lb/yd <sup>3</sup>	1517	1685	1854	2022	2191	2359	2528	2696	2865	3034	3202	3370	3539	
		m <sup>3</sup>	yd <sup>3</sup>													
General Purpose	Pin On	1.3	1.7										113%	107%	102%	
		1.4	1.8								111%	105%	100%	95%		
		1.6	2.1						115%	107%	101%					
		1.8	2.4					108%	101%	94%						
		1.9	2.5				109%	102%	95%							
	IT	1.3	1.7										111%	105%	100%	
		1.3	1.7								111%	105%	100%			
		1.5	2.0						113%	106%	100%	95%				
		1.6	2.1					112%	105%	99%						
		1.7	2.2				112%	105%	98%							
	ISO	1.9	2.5			113%	104%	97%								
		1.3	1.7										114%	108%	103%	98%
		1.5	2.0						110%	103%	98%					
		1.7	2.2					109%	102%	96%						
			1.9	2.5				110%	102%	95%						

Material density and fill factor are key variables when choosing the appropriate size of the bucket. The long floor and open throat design of the Performance Series Buckets along with the aggressive rack angles of the Cat Optimized Z-bar Loader will demonstrate fill factors greater than 100% ISO rated. Refer to the **Fill Factors** table for expected fill factor per material density and **Bucket Selection** table for bucket sizing.

### 914K — Standard Lift Fill Factors

Materials	Density	Fill %
Earth and rock	~ 1800 kg/m <sup>3</sup> ~ 3033 lb/yd <sup>3</sup>	~ 115%
Sand & gravel	~ 1700 kg/m <sup>3</sup> ~ 2865 lb/yd <sup>3</sup>	~ 115%
Aggregates	~ 1600 kg/m <sup>3</sup> ~ 2696 lb/yd <sup>3</sup>	~ 105%
Bulk grains	~ 750 kg/m <sup>3</sup> ~ 1264 lb/yd <sup>3</sup>	~ 100%
Woodchips	~ 500 kg/m <sup>3</sup> ~ 843 lb/yd <sup>3</sup>	~ 100%

**914K — High Lift**

Bucket Fill Factor		kg/m <sup>3</sup>	900	950	1000	1100	1200	1300	1400	1450	1500	1550	1600	1650	1700	
		lb/yd <sup>3</sup>	1517	1601	1685	1854	2022	2191	2359	2443	2443	2528	2696	2780	2865	
		m <sup>3</sup>														
		yd <sup>3</sup>														
General Purpose	Pin On	1.3	1.7								115%	111%	108%	104%	101%	
		1.4	1.8						114%	110%	106%	103%	100%	97%		
		1.6	2.1				115%	106%	98%	95%						
		1.8	2.4					110%	101%							
		1.9	2.5			114%	104%	95%								
	IT	1.3	1.7								112%	109%	105%	102%	99%	
		1.3	1.7							113%	109%	106%	102%	99%		
		1.5	2.0					111%	103%	100%	96%					
		1.6	2.1				112%	104%	96%							
		1.7	2.2			114%	105%	97%								
	ISO	1.9	2.5	110%	104%	99%										
		1.3	1.7								114%	110%	107%	103%	100%	97%
		1.5	2.0					109%	101%	97%	94%					
			1.7	2.2				112%	102%	95%						

Material density and fill factor are key variables when choosing the appropriate size of the bucket. The long floor and open throat design of the Performance Series Buckets along with the aggressive rack angles of the Cat Optimized Z-bar Loader will demonstrate fill factors greater than 100% ISO rated. Refer to the **Fill Factors** table for expected fill factor per material density and **Bucket Selection** table for bucket sizing.

**914K — High Lift Fill Factors**

Materials	Density	Fill %
Earth and rock	~ 1800 kg/m <sup>3</sup> ~ 3033 lb/yd <sup>3</sup>	~ 115%
Sand & gravel	~ 1700 kg/m <sup>3</sup> ~ 2865 lb/yd <sup>3</sup>	~ 115%
Aggregates	~ 1600 kg/m <sup>3</sup> ~ 2696 lb/yd <sup>3</sup>	~ 105%
Bulk grains	~ 750 kg/m <sup>3</sup> ~ 1264 lb/yd <sup>3</sup>	~ 100%
Woodchips	~ 500 kg/m <sup>3</sup> ~ 843 lb/yd <sup>3</sup>	~ 100%

### 910M — Standard Lift

Bucket Fill Factor		kg/m <sup>3</sup>	1150	1225	1300	1375	1450	1525	1600	1675	1750	1751	1825	1900	1901	1902		
		lb/yd <sup>3</sup>	1938	2064	2191	2317	2443	2570	2696	2822	2949	2950	3075	3202	3203	3205		
		m <sup>3</sup>																
		yd <sup>3</sup>																
General Purpose	Pin On	1.3	1.7									113%	113%	109%	104%	104%	104%	
		1.4	1.8							110%	105%	105%	101%	97%	97%	97%		
		1.6	2.1					110%	104%	99%	95%							
		1.8	2.4			114%	107%	101%	96%									
		1.9	2.5	114%	107%	101%	95%											
	IT	1.3	1.7									111%	111%	107%	102%	102%	102%	
		1.3	1.7							112%	111%	107%	103%	103%	103%			
		1.5	2.0					109%	104%	100%	95%	95%						
		1.6	2.1			113%	107%	102%	97%									
		1.7	2.2			112%	106%	100%	95%									
	ISO	1.3	1.7									114%	109%	109%	104%	100%	100%	100%
		1.5	2.0					112%	107%	102%	97%							
		1.7	2.2			109%	103%	98%										

Material density and fill factor are key variables when choosing the appropriate size of the bucket. The long floor and open throat design of the Performance Series Buckets along with the aggressive rack angles of the Cat Optimized Z-bar Loader will demonstrate fill factors greater than 100% ISO rated. Refer to the **Fill Factors** table for expected fill factor per material density and **Bucket Selection** table for bucket sizing.

### 910M — Standard Lift Fill Factors

Materials	Density	Fill %
Earth and rock	~ 1800 kg/m <sup>3</sup> ~ 3033 lb/yd <sup>3</sup>	~ 115%
Sand & gravel	~ 1700 kg/m <sup>3</sup> ~ 2865 lb/yd <sup>3</sup>	~ 115%
Aggregates	~ 1600 kg/m <sup>3</sup> ~ 2696 lb/yd <sup>3</sup>	~ 105%
Bulk grains	~ 750 kg/m <sup>3</sup> ~ 1264 lb/yd <sup>3</sup>	~ 100%
Woodchips	~ 500 kg/m <sup>3</sup> ~ 843 lb/yd <sup>3</sup>	~ 100%

**910M — High Lift**

Bucket Fill Factor		kg/m <sup>3</sup>	1075	1150	1225	1300	1375	1450	1525	1600	1675	1676	1750	1825	1826	1827	
		lb/yd <sup>3</sup>	1811	1938	2064	2191	2317	2443	2570	2696	2822	2824	2949	3075	3077	3078	
		m <sup>3</sup>															
		yd <sup>3</sup>															
General Purpose	Pin On	1.3	1.7									110%	110%	106%	101%	101%	101%
		1.4	1.8						112%	107%	102%	102%	98%				
		1.6	2.1				114%	108%	102%	97%							
		1.8	2.4			113%	106%	100%	95%								
		1.9	2.5	114%	107%	100%	94%										
	IT	1.3	1.7								113%	108%	108%	103%	99%	99%	99%
		1.3	1.7							113%	108%	108%	104%	99%	99%	99%	
		1.5	2.0					113%	107%	102%	97%						
		1.6	2.1				111%	105%	100%	95%							
		1.7	2.2			111%	104%	98%									
	ISO	1.3	1.7								111%	106%	106%	102%	97%	97%	97%
		1.5	2.0					111%	105%	100%	95%						
		1.7	2.2			108%	102%	96%									

Material density and fill factor are key variables when choosing the appropriate size of the bucket. The long floor and open throat design of the Performance Series Buckets along with the aggressive rack angles of the Cat Optimized Z-bar Loader will demonstrate fill factors greater than 100% ISO rated. Refer to the **Fill Factors** table for expected fill factor per material density and **Bucket Selection** table for bucket sizing.

**910M — High Lift Fill Factors**

Materials	Density	Fill %
Earth and rock	~ 1800 kg/m <sup>3</sup> ~ 3033 lb/yd <sup>3</sup>	~ 115%
Sand & gravel	~ 1700 kg/m <sup>3</sup> ~ 2865 lb/yd <sup>3</sup>	~ 115%
Aggregates	~ 1600 kg/m <sup>3</sup> ~ 2696 lb/yd <sup>3</sup>	~ 105%
Bulk grains	~ 750 kg/m <sup>3</sup> ~ 1264 lb/yd <sup>3</sup>	~ 100%
Woodchips	~ 500 kg/m <sup>3</sup> ~ 843 lb/yd <sup>3</sup>	~ 100%

### 914M — Standard Lift

Bucket Fill Factor		kg/m <sup>3</sup>		1450	1525	1600	1675	1750	1825	1900	1975	2050	2051	2125	2200	2201	2202		
		lb/yd <sup>3</sup>		2443	2570	2696	2822	2949	3075	3202	3328	3454	3456	3581	3707	3709	3710		
		m <sup>3</sup>	yd <sup>3</sup>																
General Purpose	Pin On	1.3	1.7								112%	108%	104%	104%	100%	97%	97%	97%	
		1.4	1.8					113%	108%	104%	100%	97%	96%						
		1.6	2.1			112%	107%	102%	98%										
		1.8	2.4	103%	98%														
		1.9	2.5	97%															
	IT	1.3	1.7								115%	110%	106%	102%	102%	98%	95%	95%	95%
		1.3	1.7								115%	110%	106%	102%	102%	99%	95%	95%	95%
		1.5	2.0			112%	107%	102%	98%	94%									
		1.6	2.1			109%	104%	100%	95%										
		1.7	2.2	108%	102%	98%													
	ISO	1.3	1.7								112%	108%	104%	100%	100%	96%			
		1.5	2.0			115%	109%	104%	100%	96%									
1.7		2.2	105%	100%	95%														

Material density and fill factor are key variables when choosing the appropriate size of the bucket. The long floor and open throat design of the Performance Series Buckets along with the aggressive rack angles of the Cat Optimized Z-bar Loader will demonstrate fill factors greater than 100% ISO rated. Refer to the **Fill Factors** table for expected fill factor per material density and **Bucket Selection** table for bucket sizing.

### 914M — Standard Lift Fill Factors

Materials	Density	Fill %
Earth and rock	~ 1800 kg/m <sup>3</sup> ~ 3033 lb/yd <sup>3</sup>	~ 115%
Sand & gravel	~ 1700 kg/m <sup>3</sup> ~ 2865 lb/yd <sup>3</sup>	~ 115%
Aggregates	~ 1600 kg/m <sup>3</sup> ~ 2696 lb/yd <sup>3</sup>	~ 105%
Bulk grains	~ 750 kg/m <sup>3</sup> ~ 1264 lb/yd <sup>3</sup>	~ 100%
Woodchips	~ 500 kg/m <sup>3</sup> ~ 843 lb/yd <sup>3</sup>	~ 100%



**914M — High Lift**

Bucket Fill Factor		kg/m <sup>3</sup>	1450	1400	1500	1550	1750	1850	1950	2000	2050	2051	2100	2150	2151	2152	
		lb/yd <sup>3</sup>	2443	2359	2528	2612	2949	3117	3286	3370	3454	3456	3539	3623	3624	3626	
		m <sup>3</sup>															
		yd <sup>3</sup>															
General Purpose	Pin On	1.3	1.7					111%	105%	100%	97%	95%	95%				
		1.4	1.8					103%	98%								
		1.6	2.1	108%	112%	104%	101%										
		1.5	2.0	114%			110%	106%	94%								
		1.9	2.5														
	IT	1.3	1.7					105%	99%	94%							
		1.3	1.7					105%	99%	94%							
		1.5	2.0	109%	112%	105%	102%										
		1.6	2.1	101%	105%	98%	95%										
		1.7	2.2	95%	98%												
	ISO	1.3	1.7					103%	97%								
		1.5	2.0	106%	110%	103%	99%										
		1.7	2.2			96%											

Material density and fill factor are key variables when choosing the appropriate size of the bucket. The long floor and open throat design of the Performance Series Buckets along with the aggressive rack angles of the Cat Optimized Z-bar Loader will demonstrate fill factors greater than 100% ISO rated. Refer to the **Fill Factors** table for expected fill factor per material density and **Bucket Selection** table for bucket sizing.

**914M — High Lift Fill Factors**

Materials	Density	Fill %
Earth and rock	~ 1800 kg/m <sup>3</sup>	~ 3033 lb/yd <sup>3</sup>
Sand & gravel	~ 1700 kg/m <sup>3</sup>	~ 2865 lb/yd <sup>3</sup>
Aggregates	~ 1600 kg/m <sup>3</sup>	~ 2696 lb/yd <sup>3</sup>
Bulk grains	~ 750 kg/m <sup>3</sup>	~ 1264 lb/yd <sup>3</sup>
Woodchips	~ 500 kg/m <sup>3</sup>	~ 843 lb/yd <sup>3</sup>

### 918M — Standard Lift

Bucket Fill Factor		kg/m <sup>3</sup>	1500	1600	1700	1800	1900	2000	2050	2100	2200	2250	2300	2400	2450	2500			
		lb/yd <sup>3</sup>	2528	2696	2865	3033	3202	3370	3454	3539	3707	3791	3876	4044	4128	4213			
		m <sup>3</sup>																	
		yd <sup>3</sup>																	
General Purpose	Pin On	1.3	1.7											110%	108%	105%	101%	99%	97%
		1.4	1.8						113%	110%	107%	102%	100%	98%					
		1.6	2.1				115%	108%	102%	97%	95%								
		1.8	2.4	114%	107%	101%	95%												
		1.9	2.5	107%	101%	95%													
	IT	1.3	1.7							115%	112%	109%	104%	102%	100%	95%			
		1.3	1.7						115%	112%	109%	104%	102%	100%	96%				
		1.5	2.0				109%	103%	98%	96%									
		1.6	2.1			114%	108%	102%	96%										
		1.7	2.2	114%	107%	101%	95%												
	ISO	1.3	1.7							112%	110%	107%	102%	100%	98%				
		1.5	2.0				113%	107%	101%	96%									
		1.7	2.2	111%	104%	98%													

Material density and fill factor are key variables when choosing the appropriate size of the bucket. The long floor and open throat design of the Performance Series Buckets along with the aggressive rack angles of the Cat Optimized Z-bar Loader will demonstrate fill factors greater than 100% ISO rated. Refer to the **Fill Factors** table for expected fill factor per material density and **Bucket Selection** table for bucket sizing.

### 918M — Standard Lift Fill Factors

Materials	Density	Fill %
Earth and rock	~ 1800 kg/m <sup>3</sup> ~ 3033 lb/yd <sup>3</sup>	~ 115%
Sand & gravel	~ 1700 kg/m <sup>3</sup> ~ 2865 lb/yd <sup>3</sup>	~ 115%
Aggregates	~ 1600 kg/m <sup>3</sup> ~ 2696 lb/yd <sup>3</sup>	~ 105%
Bulk grains	~ 750 kg/m <sup>3</sup> ~ 1264 lb/yd <sup>3</sup>	~ 100%
Woodchips	~ 500 kg/m <sup>3</sup> ~ 843 lb/yd <sup>3</sup>	~ 100%

# Wheel Loaders Integrated Toolcarriers

## Bucket Selection

● 926M, 930M, 938M General Purpose — Standard Lift

Material Type		Fill Factor %											Tip Load Full Turn*				
		105%	105%	110%	105%	105%	110%	105%	105%	110%	115%	110%	110%	2075	2150	kg	lb
		m <sup>3</sup>	Counter-weight	kg/m <sup>3</sup>	1400	1475	1550	1625	1700	1775	1850	1925	2000	2075	2150	kg	lb
		yd <sup>3</sup>	lb/yd <sup>3</sup>	(2,359)	(2,485)	(2,612)	(2,738)	(2,865)	(2,991)	(3,117)	(3,244)	(3,370)	(3,496)	(3,623)			
926M	Pin On	1.9	Log/Agg								115%	110%	105%	100%		8318	(18,338)
			Heavy								110%	105%				7894	(17,403)
		2.1	Log/Agg					115%	110%	105%	100%					8257	(18,204)
			Heavy					110%	105%	100%						7836	(17,275)
		2.3	Log/Agg			115%	110%	105%	100%							8156	(17,980)
			Heavy		115%	110%	105%	100%								7737	(17,057)
	Fusion	1.9	Log/Agg								115%	110%	105%	100%		7942	(17,509)
			Heavy								110%	105%	100%		7524	(16,587)	
		2.1	Log/Agg				115%	110%	105%	100%					7862	(17,333)	
			Heavy			115%	110%	105%	100%						7445	(16,413)	
		2.3	Log/Agg			115%	110%	105%	100%						7783	(17,159)	
			Heavy	115%	110%	105%	100%								7371	(16,250)	
930M	Pin On	2.1	Log/Agg								115%	110%	105%	100%		9295	(20,491)
			Heavy								110%	105%	100%		8873	(19,561)	
		2.3	Log/Agg					115%	110%	105%	100%				9186	(20,252)	
			Heavy					110%	105%	100%					8769	(19,332)	
		2.5	Log/Agg			115%	110%	105%	100%						9055	(19,962)	
			Heavy		115%	110%	105%	100%							8639	(19,045)	
	Fusion	2.1	Log/Agg								115%	110%	105%	100%		8883	(19,583)
			Heavy								110%	105%	100%		8469	(18,670)	
		2.3	Log/Agg				115%	110%	105%	100%					8804	(19,410)	
			Heavy			115%	110%	105%	100%						8390	(18,497)	
		2.5	Log/Agg		115%	110%	105%	100%							8690	(19,158)	
			Heavy	115%	110%	105%	100%								8278	(18,249)	
938M	Pin On	2.5	Log/Agg								115%	110%	105%	100%		10 925	(24,085)
			Heavy								110%	105%	100%		10 517	(23,186)	
		2.7	Log/Agg					115%	110%	105%	100%				10 015	(22,079)	
			Heavy					110%	105%	100%					10 832	(23,881)	
		2.9	Log/Agg			115%	110%	105%	100%						10 426	(22,985)	
			Heavy		115%	110%	105%	100%							9925	(21,881)	
	Fusion	2.5	Log/Agg								115%	110%	105%	100%		10 430	(22,994)
			Heavy								110%	105%	100%		10 028	(22,107)	
		2.7	Log/Agg				115%	110%	105%	100%					10 341	(22,798)	
			Heavy			115%	110%	105%	100%						9938	(21,909)	
		2.9	Log/Agg			115%	110%	105%	100%						10 266	(22,632)	
			Heavy	115%	110%	105%	100%								9864	(21,746)	

Material density, fill factor, and counterweight options are key variables when choosing the appropriate size of the bucket. The long floor and open throat design of the Performance Series Buckets along with the aggressive rack angles of the optimized linkage will demonstrate fill factors greater than 100% ISO rated. Refer to the expected fill factor % per material type at the top of the table and find a matching counterweight and fill factor along the side for proper bucket sizing.

\*Full compliance to ISO 14397-1 (2007) Sections 1 thru 6, which requires 2% verification between calculation and testing.

Material Type		Fill Factor %											Tip Load Full Turn*							
		100%	110%	115%	110%	110%	110%	110%	105%	105%	110%	110%			110%	110%	105%	110%	110%	110%
926M	Pin On	m <sup>3</sup>	Counter-weight	kg/m <sup>3</sup> lb/yd <sup>3</sup>	Bulk Grain	Construction and Demolition Silage, Packed	Manure/Muck, Wet	Coal Bituminous, Wet Peat, Moist	Coal Bituminous, Raw	Sugar, Raw Cane	Fertilizer, Mixed	Coal Anthracite, Washed Gypsum, Pulverized Peat, Wet	Coal Anthracite, Raw Earth, Loam, Dry Salt, Fine	Heavy Metal Scrap, Loose	kg	lb				
		926M	Pin On	3.1 (4.1)	Log/Agg									115%	110%	105%	7880	(17,372)		
3.1 (4.1)	Heavy												110%	100%	7463	(16,453)				
3.5 (4.6)	Log/Agg								115%	110%	105%	100%			7735	(17,052)				
3.5 (4.6)	Heavy								110%	105%	100%				7321	(16,140)				
3.8 (5.0)	Log/Agg					115%	110%	105%	100%						7600	(16,755)				
3.8 (5.0)	Heavy			115%	110%	105%	100%								7190	(15,850)				
Fusion	3.1 (4.1)		Log/Agg								115%	110%	105%	100%	7533	(16,607)				
	3.1 (4.1)		Heavy						115%	110%	105%	100%			7124	(15,705)				
	3.5 (4.6)		Log/Agg						115%	110%	105%	100%			7364	(16,234)				
	3.5 (4.6)		Heavy		115%	110%	105%	100%							6957	(15,337)				
	3.8 (5.0)		Log/Agg		115%	110%	105%	100%							7235	(15,950)				
	3.8 (5.0)		Heavy	110%	105%	100%									6830	(15,057)				
930M	Pin On	3.5 (4.6)	Log/Agg								115%	110%	105%	100%	8750	(19,290)				
		3.5 (4.6)	Heavy							115%	110%	105%	100%	8337	(18,379)					
		3.8 (5.0)	Standard							115%	110%	105%	100%	7840	(17,284)					
		3.8 (5.0)	Log/Agg						115%	110%	105%	100%			8603	(18,966)				
		3.8 (5.0)	Heavy					115%	110%	105%	100%			8198	(18,073)					
		4.2 (5.5)	Standard		115%	110%	105%	100%							7706	(16,989)				
	Fusion	3.5 (4.6)	Log/Agg								115%	110%	105%	100%	8365	(18,441)				
		3.5 (4.6)	Heavy						115%	110%	105%	100%			7960	(17,548)				
		3.8 (5.0)	Log/Agg						115%	110%	105%	100%			8231	(18,145)				
		3.8 (5.0)	Heavy			115%	110%	105%	100%						7825	(17,251)				
		4.2 (5.5)	Log/Agg		115%	110%	105%	100%							8106	(17,870)				
		4.2 (5.5)	Heavy	115%	110%	105%	100%								7707	(16,991)				
938M	Pin On	3.8 (5.0)	Log/Agg									115%	110%	105%	10412	(22,954)				
		3.8 (5.0)	Heavy									110%	105%	10015	(22,079)					
		4.2 (5.5)	Standard								115%	110%	105%	100%	9523	(20,994)				
		4.2 (5.5)	Log/Agg							115%	110%	105%	100%		10265	(22,630)				
		4.2 (5.5)	Heavy						115%	110%	105%	100%			9870	(21,759)				
		5.0 (6.5)	Standard					115%	110%	105%	100%				9383	(20,685)				
	Fusion	3.8 (5.0)	Log/Agg									115%	110%	105%	100%	9933	(21,898)			
		3.8 (5.0)	Heavy								115%	110%	105%	100%	9542	(21,036)				
		4.2 (5.5)	Log/Agg							115%	110%	105%	100%		9811	(21,629)				
		4.2 (5.5)	Heavy					115%	110%	105%	100%				9416	(20,759)				
		5.0 (6.5)	Log/Agg		115%	110%	105%	100%							9770	(21,539)				
		5.0 (6.5)	Heavy	115%	110%	105%	100%								9383	(20,685)				

Material density, fill factor, and counterweight options are key variables when choosing the appropriate size of the bucket. The long floor and open throat design of the Performance Series Buckets along with the aggressive rack angles of the optimized linkage will demonstrate fill factors greater than 100% ISO rated. Refer to the expected fill factor % per material type at the top of the table and find a matching counterweight and fill factor along the side for proper bucket sizing.

\*Full compliance to ISO 14397-1 (2007) Sections 1 thru 6, which requires 2% verification between calculation and testing.

# Wheel Loaders Integrated Toolcarriers

## Bucket Selection

● 926M, 930M, 938M General Purpose — High Lift

Material Type		Fill Factor %														Tip Load Full Turn*		
		105% Fertilizer, Mixed	110% Coal Anthracite, Washed	110% Gypsum, Pulverized	110% Peat, Wet	110% Coal Anthracite, Raw	110% Earth, Loam, Dry	105% Silt, Fine	110% Heavy Mineral Scrap, Loose	110% Shale	1345	1390	1435	1480				
926M High Lift	Pin On	m <sup>3</sup>	Counter-weight	kg/m <sup>3</sup>	1030	1075	1120	1165	1210	1255	1300	1345	1390	1435	1480	kg	lb	
		yd <sup>3</sup>	Log/Agg	lb/yd <sup>3</sup>	(1,736)	(1,811)	(1,887)	(1,963)	(2,039)	(2,115)	(2,191)	(2,266)	(2,342)	(2,418)	(2,494)			
		1.9	Heavy	Not Available														
		2.1	Standard	115%													5970	(13,161)
		2.3	Log/Agg	Not Available														
		2.3	Heavy	115%													5926	(13,065)
	Fusion	1.9	Log/Agg	Not Available														
		2.1	Heavy	115%													5628	(12,407)
		2.3	Log/Agg	Not Available														
		2.3	Heavy	115%													5561	(12,259)
		2.3	Log/Agg	Not Available														
		2.3	Heavy	115%													5497	(12,118)
930M High Lift	Pin On	m <sup>3</sup>	Counter-weight	kg/m <sup>3</sup>	1030	1075	1120	1165	1210	1255	1300	1345	1390	1435	1480	kg	lb	
		yd <sup>3</sup>	Log/Agg	lb/yd <sup>3</sup>	(1,736)	(1,811)	(1,887)	(1,963)	(2,039)	(2,115)	(2,191)	(2,266)	(2,342)	(2,418)	(2,494)			
		2.1	Heavy	Not Available														
		2.1	Standard	115%													6384	(14,074)
		2.3	Log/Agg	Not Available														
		2.3	Heavy	115%													6297	(13,883)
	Fusion	2.5	Log/Agg	Not Available														
		2.5	Heavy	115%													5906	(13,021)
		2.5	Standard	115%													6185	(13,635)
		2.5	Log/Agg	Not Available														
		2.5	Heavy	115%													5795	(12,775)
		2.5	Standard	115%													6014	(13,259)
938M High Lift	Pin On	m <sup>3</sup>	Counter-weight	kg/m <sup>3</sup>	1030	1075	1120	1165	1210	1255	1300	1345	1390	1435	1480	kg	lb	
		yd <sup>3</sup>	Log/Agg	lb/yd <sup>3</sup>	(1,736)	(1,811)	(1,887)	(1,963)	(2,039)	(2,115)	(2,191)	(2,266)	(2,342)	(2,418)	(2,494)			
		2.5	Heavy	Not Available														
		2.5	Standard	115%													7370	(16,248)
		2.7	Log/Agg	Not Available														
		2.7	Heavy	115%													7301	(16,095)
	Fusion	2.9	Log/Agg	Not Available														
		2.9	Heavy	115%													7244	(15,970)
		2.9	Standard	115%													6940	(15,300)
		2.7	Log/Agg	Not Available														
		2.7	Heavy	115%													6869	(15,143)
		2.9	Standard	115%													6815	(15,024)

Material density, fill factor, and counterweight options are key variables when choosing the appropriate size of the bucket. The long floor and open throat design of the Performance Series Buckets along with the aggressive rack angles of the optimized linkage will demonstrate fill factors greater than 100% ISO rated. Refer to the expected fill factor % per material type at the top of the table and find a matching counterweight and fill factor along the side for proper bucket sizing.

\*Full compliance to ISO 14397-1 (2007) Sections 1 thru 6, which requires 2% verification between calculation and testing.

Material Type		Fill Factor %													Tip Load Full Turn*			
		115% Mulch, Wet	115% Municipal Solid Waste	110% Flour, Wheat	115% Compacted Solid Waste	100% Barley, Bulk	100% Buckwheat, Bulk	670	700	730	760	790	820	850				
926M High Lift	Pin On	m <sup>3</sup>	Counter-weight	kg/m <sup>2</sup>	550	580	610	640	670	700	730	760	790	820	850	kg	lb	
		yd <sup>3</sup>	Log/Agg Heavy	lb/yd <sup>2</sup>	(927)	(977)	(1,028)	(1,078)	(1,129)	(1,180)	(1,230)	(1,281)	(1,331)	(1,382)	(1,432)			
		3.1 (4.1)	Not Available															
		3.5 (4.6)	Not Available															
		3.8 (5.0)	Not Available															
		Heavy	Not Available															
	Fusion	3.1 (4.1)	Not Available															
		3.5 (4.6)	Not Available															
		3.8 (5.0)	Not Available															
		Heavy	Not Available															
930M High Lift	Pin On	m <sup>3</sup>	Counter-weight	kg/m <sup>2</sup>	550	580	610	640	670	700	730	760	790	820	850	kg	lb	
		yd <sup>3</sup>	Log/Agg Heavy	lb/yd <sup>2</sup>	(927)	(977)	(1,028)	(1,078)	(1,129)	(1,180)	(1,230)	(1,281)	(1,331)	(1,382)	(1,432)			
		3.5 (4.6)	Not Available															
		3.8 (5.0)	Not Available															
		4.2 (5.5)	Not Available															
		Heavy	Not Available															
	Fusion	3.5 (4.6)	Not Available															
		3.8 (5.0)	Not Available															
		4.2 (5.5)	Not Available															
		Heavy	Not Available															

Material density, fill factor, and counterweight options are key variables when choosing the appropriate size of the bucket. The long floor and open throat design of the Performance Series Buckets along with the aggressive rack angles of the optimized linkage will demonstrate fill factors greater than 100% ISO rated. Refer to the expected fill factor % per material type at the top of the table and find a matching counterweight and fill factor along the side for proper bucket sizing.

\*Full compliance to ISO 14397-1 (2007) Sections 1 thru 6, which requires 2% verification between calculation and testing.

### 950L

Material Density		kg/m <sup>3</sup>	700	800	900	1000	1100	1200	1300	1400	1500	1600	1700	1800	1900	2000	2100	2200	2300	2400	2500		
Standard Linkage	Pin On	General Purpose	2.70 m <sup>3</sup> (3.53 yd <sup>3</sup> )																				
		General Purpose	3.10 m <sup>3</sup> (4.05 yd <sup>3</sup> )																				
		General Purpose	3.40 m <sup>3</sup> (4.45 yd <sup>3</sup> )																				
	Hook On	General Purpose	3.10 m <sup>3</sup> (4.05 yd <sup>3</sup> )																				
		Material Handling	3.20 m <sup>3</sup> (4.19 yd <sup>3</sup> )																				
		Material Handling	3.40 m <sup>3</sup> (4.45 yd <sup>3</sup> )																				
Auxiliary Counterweight	Pin On	General Purpose	3.30 m <sup>3</sup> (4.32 yd <sup>3</sup> )																				
		General Purpose	3.60 m <sup>3</sup> (4.71 yd <sup>3</sup> )																				
	Hook On	General Purpose	3.40 m <sup>3</sup> (4.45 yd <sup>3</sup> )																				
Material Density		lb/yd <sup>3</sup>	1180	1348	1517	1685	1854	2022	2191	2359	2528	2696	2865	3033	3202	3370	3539	3707	3876	4044	4213		
Bucket Fill Factors		115% 110% 105% 100% 95%																					

**NOTE:** All buckets are showing Bolt-on Edges except the Rock Bucket is showing Tips.  
Machine and bucket availability varies by region. Contact your local Cat dealer for product availability.

950M

Material Density		kg/m <sup>3</sup>	700	800	900	1000	1100	1200	1300	1400	1500	1600	1700	1800	1900	2000	2100	2200	2300	2400	2500	
Standard Linkage	Pin On	General Purpose	2.70 m <sup>3</sup> (3.53 yd <sup>3</sup> )												3.11 m <sup>3</sup> (4.07 yd <sup>3</sup> )						2.70 m <sup>3</sup> (3.53 yd <sup>3</sup> )	
			2.90 m <sup>3</sup> (3.79 yd <sup>3</sup> )												3.34 m <sup>3</sup> (4.37 yd <sup>3</sup> )						2.90 m <sup>3</sup> (3.79 yd <sup>3</sup> )	
			3.10 m <sup>3</sup> (4.05 yd <sup>3</sup> )													3.57 m <sup>3</sup> (4.67 yd <sup>3</sup> )						3.10 m <sup>3</sup> (4.05 yd <sup>3</sup> )
			3.30 m <sup>3</sup> (4.32 yd <sup>3</sup> )													3.80 m <sup>3</sup> (4.97 yd <sup>3</sup> )						3.30 m <sup>3</sup> (4.32 yd <sup>3</sup> )
			3.40 m <sup>3</sup> (4.45 yd <sup>3</sup> )													3.91 m <sup>3</sup> (5.11 yd <sup>3</sup> )						3.40 m <sup>3</sup> (4.45 yd <sup>3</sup> )
			3.60 m <sup>3</sup> (4.71 yd <sup>3</sup> )													4.14 m <sup>3</sup> (5.41 yd <sup>3</sup> )						3.60 m <sup>3</sup> (4.71 yd <sup>3</sup> )
			3.80 m <sup>3</sup> (4.97 yd <sup>3</sup> )													4.37 m <sup>3</sup> (5.72 yd <sup>3</sup> )						3.80 m <sup>3</sup> (4.97 yd <sup>3</sup> )
	Material Handling	2.70 m <sup>3</sup> (3.53 yd <sup>3</sup> )														3.11 m <sup>3</sup> (4.07 yd <sup>3</sup> )						2.70 m <sup>3</sup> (3.53 yd <sup>3</sup> )
		2.90 m <sup>3</sup> (3.79 yd <sup>3</sup> )														3.34 m <sup>3</sup> (4.37 yd <sup>3</sup> )						2.90 m <sup>3</sup> (3.79 yd <sup>3</sup> )
		3.10 m <sup>3</sup> (4.05 yd <sup>3</sup> )														3.57 m <sup>3</sup> (4.67 yd <sup>3</sup> )						3.10 m <sup>3</sup> (4.05 yd <sup>3</sup> )
		3.30 m <sup>3</sup> (4.32 yd <sup>3</sup> )														3.80 m <sup>3</sup> (4.97 yd <sup>3</sup> )						3.30 m <sup>3</sup> (4.32 yd <sup>3</sup> )
		3.40 m <sup>3</sup> (4.45 yd <sup>3</sup> )														3.91 m <sup>3</sup> (5.11 yd <sup>3</sup> )						3.40 m <sup>3</sup> (4.45 yd <sup>3</sup> )
		3.60 m <sup>3</sup> (4.71 yd <sup>3</sup> )														4.14 m <sup>3</sup> (5.41 yd <sup>3</sup> )						3.60 m <sup>3</sup> (4.71 yd <sup>3</sup> )
		3.80 m <sup>3</sup> (4.97 yd <sup>3</sup> )														4.37 m <sup>3</sup> (5.72 yd <sup>3</sup> )						3.80 m <sup>3</sup> (4.97 yd <sup>3</sup> )
Hook On	General Purpose	2.70 m <sup>3</sup> (3.53 yd <sup>3</sup> )													3.11 m <sup>3</sup> (4.07 yd <sup>3</sup> )						2.70 m <sup>3</sup> (3.53 yd <sup>3</sup> )	
		2.90 m <sup>3</sup> (3.79 yd <sup>3</sup> )														3.34 m <sup>3</sup> (4.37 yd <sup>3</sup> )						2.90 m <sup>3</sup> (3.79 yd <sup>3</sup> )
		3.10 m <sup>3</sup> (4.05 yd <sup>3</sup> )														3.57 m <sup>3</sup> (4.67 yd <sup>3</sup> )						3.10 m <sup>3</sup> (4.05 yd <sup>3</sup> )
		3.30 m <sup>3</sup> (4.32 yd <sup>3</sup> )														3.80 m <sup>3</sup> (4.97 yd <sup>3</sup> )						3.30 m <sup>3</sup> (4.32 yd <sup>3</sup> )
		3.40 m <sup>3</sup> (4.45 yd <sup>3</sup> )														3.91 m <sup>3</sup> (5.11 yd <sup>3</sup> )						3.40 m <sup>3</sup> (4.45 yd <sup>3</sup> )
		3.60 m <sup>3</sup> (4.71 yd <sup>3</sup> )														4.14 m <sup>3</sup> (5.41 yd <sup>3</sup> )						3.60 m <sup>3</sup> (4.71 yd <sup>3</sup> )
		3.80 m <sup>3</sup> (4.97 yd <sup>3</sup> )														4.37 m <sup>3</sup> (5.72 yd <sup>3</sup> )						3.80 m <sup>3</sup> (4.97 yd <sup>3</sup> )
Material Handling	2.70 m <sup>3</sup> (3.53 yd <sup>3</sup> )														3.11 m <sup>3</sup> (4.07 yd <sup>3</sup> )						2.70 m <sup>3</sup> (3.53 yd <sup>3</sup> )	
	2.90 m <sup>3</sup> (3.79 yd <sup>3</sup> )														3.34 m <sup>3</sup> (4.37 yd <sup>3</sup> )						2.90 m <sup>3</sup> (3.79 yd <sup>3</sup> )	
	3.10 m <sup>3</sup> (4.05 yd <sup>3</sup> )														3.57 m <sup>3</sup> (4.67 yd <sup>3</sup> )						3.10 m <sup>3</sup> (4.05 yd <sup>3</sup> )	
	3.30 m <sup>3</sup> (4.32 yd <sup>3</sup> )														3.80 m <sup>3</sup> (4.97 yd <sup>3</sup> )						3.30 m <sup>3</sup> (4.32 yd <sup>3</sup> )	
	3.40 m <sup>3</sup> (4.45 yd <sup>3</sup> )														3.91 m <sup>3</sup> (5.11 yd <sup>3</sup> )						3.40 m <sup>3</sup> (4.45 yd <sup>3</sup> )	
	3.60 m <sup>3</sup> (4.71 yd <sup>3</sup> )														4.14 m <sup>3</sup> (5.41 yd <sup>3</sup> )						3.60 m <sup>3</sup> (4.71 yd <sup>3</sup> )	
	3.80 m <sup>3</sup> (4.97 yd <sup>3</sup> )														4.37 m <sup>3</sup> (5.72 yd <sup>3</sup> )						3.80 m <sup>3</sup> (4.97 yd <sup>3</sup> )	
Material Density	lb/yd <sup>3</sup>	1180	1348	1517	1685	1854	2022	2191	2359	2528	2696	2865	3033	3202	3370	3539	3707	3876	4044	4213		
Bucket Fill Factors 115% 110% 105% 100% 95%																						

NOTE: All buckets are showing Bolt-On Edges.  
Machine and bucket availability varies by region. Contact your local Cat dealer for product availability.



**962L**

Material Density		kg/m <sup>3</sup>	700	800	900	1000	1100	1200	1300	1400	1500	1600	1700	1800	1900	2000	2100	2200	2300	2400	2500			
Standard Linkage	Pin On	General Purpose	3.40 m <sup>3</sup> (4.45 yd <sup>3</sup> )																					
			3.60 m <sup>3</sup> (4.71 yd <sup>3</sup> )																					
	Hook On	General Purpose	3.40 m <sup>3</sup> (4.45 yd <sup>3</sup> )																					
			3.91 m <sup>3</sup> (5.11 yd <sup>3</sup> )																					
	Pin On	Material Handling	3.40 m <sup>3</sup> (4.45 yd <sup>3</sup> )																					
			3.60 m <sup>3</sup> (4.71 yd <sup>3</sup> )																					
			3.80 m <sup>3</sup> (4.97 yd <sup>3</sup> )																					
	Pin On	Rock	3.10 m <sup>3</sup> (4.05 yd <sup>3</sup> )																					
			3.57 m <sup>3</sup> (4.67 yd <sup>3</sup> )																					
	Material Density		lb/yr <sup>3</sup>	1180	1348	1517	1685	1854	2022	2191	2359	2528	2696	2865	3033	3202	3370	3539	3707	3876	4044	4213		
	Bucket Fill Factors		115% 110% 105% 100% 95% 																					

**NOTE:** All buckets are showing Bolt-on Edges except the Rock Bucket is showing Tips.  
Machine and bucket availability varies by region. Contact your local Cat dealer for product availability.

962M

Material Density		kg/m <sup>3</sup>	700	800	900	1000	1100	1200	1300	1400	1500	1600	1700	1800	1900	2000	2100	2200	2300	2400	2500		
Standard Linkage	Pin On	General Purpose	2.70 m <sup>3</sup> (3.53 yd <sup>3</sup> )													3.11 m <sup>3</sup> (4.07 yd <sup>3</sup> )						2.70 m <sup>3</sup> (3.53 yd <sup>3</sup> )	
			2.90 m <sup>3</sup> (3.79 yd <sup>3</sup> )													3.34 m <sup>3</sup> (4.37 yd <sup>3</sup> )						2.90 m <sup>3</sup> (3.79 yd <sup>3</sup> )	
			3.10 m <sup>3</sup> (4.05 yd <sup>3</sup> )													3.57 m <sup>3</sup> (4.67 yd <sup>3</sup> )						3.10 m <sup>3</sup> (4.05 yd <sup>3</sup> )	
			3.30 m <sup>3</sup> (4.32 yd <sup>3</sup> )													3.80 m <sup>3</sup> (4.97 yd <sup>3</sup> )						3.30 m <sup>3</sup> (4.32 yd <sup>3</sup> )	
			3.40 m <sup>3</sup> (4.45 yd <sup>3</sup> )													3.91 m <sup>3</sup> (5.11 yd <sup>3</sup> )						3.40 m <sup>3</sup> (4.45 yd <sup>3</sup> )	
			3.60 m <sup>3</sup> (4.71 yd <sup>3</sup> )													4.14 m <sup>3</sup> (5.41 yd <sup>3</sup> )						3.60 m <sup>3</sup> (4.71 yd <sup>3</sup> )	
			3.80 m <sup>3</sup> (4.97 yd <sup>3</sup> )													4.37 m <sup>3</sup> (5.72 yd <sup>3</sup> )						3.80 m <sup>3</sup> (4.97 yd <sup>3</sup> )	
	Material Handling	2.70 m <sup>3</sup> (3.53 yd <sup>3</sup> )															3.11 m <sup>3</sup> (4.07 yd <sup>3</sup> )						2.70 m <sup>3</sup> (3.53 yd <sup>3</sup> )
		2.90 m <sup>3</sup> (3.79 yd <sup>3</sup> )															3.34 m <sup>3</sup> (4.37 yd <sup>3</sup> )						2.90 m <sup>3</sup> (3.79 yd <sup>3</sup> )
		3.10 m <sup>3</sup> (4.05 yd <sup>3</sup> )															3.57 m <sup>3</sup> (4.67 yd <sup>3</sup> )						3.10 m <sup>3</sup> (4.05 yd <sup>3</sup> )
		3.30 m <sup>3</sup> (4.32 yd <sup>3</sup> )															3.80 m <sup>3</sup> (4.97 yd <sup>3</sup> )						3.30 m <sup>3</sup> (4.32 yd <sup>3</sup> )
		3.40 m <sup>3</sup> (4.45 yd <sup>3</sup> )															3.91 m <sup>3</sup> (5.11 yd <sup>3</sup> )						3.40 m <sup>3</sup> (4.45 yd <sup>3</sup> )
		3.60 m <sup>3</sup> (4.71 yd <sup>3</sup> )															4.14 m <sup>3</sup> (5.41 yd <sup>3</sup> )						3.60 m <sup>3</sup> (4.71 yd <sup>3</sup> )
		3.80 m <sup>3</sup> (4.97 yd <sup>3</sup> )															4.37 m <sup>3</sup> (5.72 yd <sup>3</sup> )						3.80 m <sup>3</sup> (4.97 yd <sup>3</sup> )
Hook On	General Purpose	2.70 m <sup>3</sup> (3.53 yd <sup>3</sup> )														3.11 m <sup>3</sup> (4.07 yd <sup>3</sup> )						2.70 m <sup>3</sup> (3.53 yd <sup>3</sup> )	
		2.90 m <sup>3</sup> (3.79 yd <sup>3</sup> )															3.34 m <sup>3</sup> (4.37 yd <sup>3</sup> )						2.90 m <sup>3</sup> (3.79 yd <sup>3</sup> )
		3.10 m <sup>3</sup> (4.05 yd <sup>3</sup> )															3.57 m <sup>3</sup> (4.67 yd <sup>3</sup> )						3.10 m <sup>3</sup> (4.05 yd <sup>3</sup> )
		3.30 m <sup>3</sup> (4.32 yd <sup>3</sup> )															3.80 m <sup>3</sup> (4.97 yd <sup>3</sup> )						3.30 m <sup>3</sup> (4.32 yd <sup>3</sup> )
		3.40 m <sup>3</sup> (4.45 yd <sup>3</sup> )															3.91 m <sup>3</sup> (5.11 yd <sup>3</sup> )						3.40 m <sup>3</sup> (4.45 yd <sup>3</sup> )
		3.60 m <sup>3</sup> (4.71 yd <sup>3</sup> )															4.14 m <sup>3</sup> (5.41 yd <sup>3</sup> )						3.60 m <sup>3</sup> (4.71 yd <sup>3</sup> )
		3.80 m <sup>3</sup> (4.97 yd <sup>3</sup> )															4.37 m <sup>3</sup> (5.72 yd <sup>3</sup> )						3.80 m <sup>3</sup> (4.97 yd <sup>3</sup> )
Material Handling	2.70 m <sup>3</sup> (3.53 yd <sup>3</sup> )															3.11 m <sup>3</sup> (4.07 yd <sup>3</sup> )						2.70 m <sup>3</sup> (3.53 yd <sup>3</sup> )	
	2.90 m <sup>3</sup> (3.79 yd <sup>3</sup> )															3.34 m <sup>3</sup> (4.37 yd <sup>3</sup> )						2.90 m <sup>3</sup> (3.79 yd <sup>3</sup> )	
	3.10 m <sup>3</sup> (4.05 yd <sup>3</sup> )															3.57 m <sup>3</sup> (4.67 yd <sup>3</sup> )						3.10 m <sup>3</sup> (4.05 yd <sup>3</sup> )	
	3.30 m <sup>3</sup> (4.32 yd <sup>3</sup> )															3.80 m <sup>3</sup> (4.97 yd <sup>3</sup> )						3.30 m <sup>3</sup> (4.32 yd <sup>3</sup> )	
	3.40 m <sup>3</sup> (4.45 yd <sup>3</sup> )															3.91 m <sup>3</sup> (5.11 yd <sup>3</sup> )						3.40 m <sup>3</sup> (4.45 yd <sup>3</sup> )	
	3.60 m <sup>3</sup> (4.71 yd <sup>3</sup> )															4.14 m <sup>3</sup> (5.41 yd <sup>3</sup> )						3.60 m <sup>3</sup> (4.71 yd <sup>3</sup> )	
	3.80 m <sup>3</sup> (4.97 yd <sup>3</sup> )															4.37 m <sup>3</sup> (5.72 yd <sup>3</sup> )						3.80 m <sup>3</sup> (4.97 yd <sup>3</sup> )	
Material Density	lb/yd <sup>3</sup>	1180	1348	1517	1685	1854	2022	2191	2359	2528	2696	2865	3033	3202	3370	3539	3707	3876	4044	4213			
Bucket Fill Factors 115% 110% 105% 100% 95%																							

NOTE: All buckets are showing Bolt-On Edges.  
Machine and bucket availability varies by region. Contact your local Cat dealer for product availability.

**962M**

Material Density		kg/m <sup>3</sup>	700	800	900	1000	1100	1200	1300	1400	1500	1600	1700	1800	1900	2000	2100	2200	2300	2400	2500		
Aggregate Package Linkage Pin On General Purpose	3.80 m <sup>3</sup> (4.97 yd <sup>3</sup> )									4.37 m <sup>3</sup> (5.72 yd <sup>3</sup> )													
	4.00 m <sup>3</sup> (5.23 yd <sup>3</sup> )								4.60 m <sup>3</sup> (6.02 yd <sup>3</sup> )														
	4.20 m <sup>3</sup> (5.49 yd <sup>3</sup> )							4.83 m <sup>3</sup> (6.32 yd <sup>3</sup> )				4.20 m <sup>3</sup> (5.49 yd <sup>3</sup> )											
Material Density	lb/yd <sup>3</sup>		1180	1348	1517	1685	1854	2022	2191	2359	2528	2696	2865	3033	3202	3370	3539	3707	3876	4044	4213		
Bucket Fill Factors 115% 110% 105% 100% 95%																							

**NOTE:** All buckets are showing Bolt-On Edges.  
Machine and bucket availability varies by region. Contact your local Cat dealer for product availability.

966L/966M

Material Density		kg/m <sup>3</sup>	700	800	900	1000	1100	1200	1300	1400	1500	1600	1700	1800	1900	2000	2100	2200	2300	2400	2500		
Standard Linkage	Pin On	General Purpose	3.80 m <sup>3</sup> (5.00 yd <sup>3</sup> )											4.37 m <sup>3</sup> (5.72 yd <sup>3</sup> )								3.80 m <sup>3</sup> (5.00 yd <sup>3</sup> )	
			4.00 m <sup>3</sup> (5.25 yd <sup>3</sup> )											4.60 m <sup>3</sup> (6.02 yd <sup>3</sup> )								4.00 m <sup>3</sup> (5.25 yd <sup>3</sup> )	
			4.20 m <sup>3</sup> (5.50 yd <sup>3</sup> )											4.83 m <sup>3</sup> (6.32 yd <sup>3</sup> )								4.20 m <sup>3</sup> (5.50 yd <sup>3</sup> )	
	Fusion QC	General Purpose	3.80 m <sup>3</sup> (5.00 yd <sup>3</sup> )												4.37 m <sup>3</sup> (5.72 yd <sup>3</sup> )								3.80 m <sup>3</sup> (5.00 yd <sup>3</sup> )
			4.20 m <sup>3</sup> (5.50 yd <sup>3</sup> )											4.83 m <sup>3</sup> (6.32 yd <sup>3</sup> )								4.20 m <sup>3</sup> (5.50 yd <sup>3</sup> )	
			4.20 m <sup>3</sup> (5.50 yd <sup>3</sup> )													4.83 m <sup>3</sup> (6.32 yd <sup>3</sup> )							4.20 m <sup>3</sup> (5.50 yd <sup>3</sup> )
	Pin On	Material Handling	4.20 m <sup>3</sup> (5.50 yd <sup>3</sup> )												4.83 m <sup>3</sup> (6.32 yd <sup>3</sup> )								4.20 m <sup>3</sup> (5.50 yd <sup>3</sup> )
			3.80 m <sup>3</sup> (5.00 yd <sup>3</sup> )													4.37 m <sup>3</sup> (5.72 yd <sup>3</sup> )							3.80 m <sup>3</sup> (5.00 yd <sup>3</sup> )
			4.00 m <sup>3</sup> (5.25 yd <sup>3</sup> )													4.60 m <sup>3</sup> (6.02 yd <sup>3</sup> )							4.00 m <sup>3</sup> (5.25 yd <sup>3</sup> )
High Lift Linkage	Pin On	General Purpose	3.80 m <sup>3</sup> (5.00 yd <sup>3</sup> )											4.37 m <sup>3</sup> (5.72 yd <sup>3</sup> )								3.80 m <sup>3</sup> (5.00 yd <sup>3</sup> )	
			4.00 m <sup>3</sup> (5.25 yd <sup>3</sup> )													4.60 m <sup>3</sup> (6.02 yd <sup>3</sup> )							4.00 m <sup>3</sup> (5.25 yd <sup>3</sup> )
			4.20 m <sup>3</sup> (5.50 yd <sup>3</sup> )													4.83 m <sup>3</sup> (6.32 yd <sup>3</sup> )							4.20 m <sup>3</sup> (5.50 yd <sup>3</sup> )
	Fusion QC	General Purpose	3.80 m <sup>3</sup> (5.00 yd <sup>3</sup> )												4.37 m <sup>3</sup> (5.72 yd <sup>3</sup> )								3.80 m <sup>3</sup> (5.00 yd <sup>3</sup> )
			4.20 m <sup>3</sup> (5.50 yd <sup>3</sup> )													4.83 m <sup>3</sup> (6.32 yd <sup>3</sup> )							4.20 m <sup>3</sup> (5.50 yd <sup>3</sup> )
			4.20 m <sup>3</sup> (5.50 yd <sup>3</sup> )													4.83 m <sup>3</sup> (6.32 yd <sup>3</sup> )							4.20 m <sup>3</sup> (5.50 yd <sup>3</sup> )
	Pin On	Material Handling	4.20 m <sup>3</sup> (5.50 yd <sup>3</sup> )												4.83 m <sup>3</sup> (6.32 yd <sup>3</sup> )								4.20 m <sup>3</sup> (5.50 yd <sup>3</sup> )
			3.80 m <sup>3</sup> (5.00 yd <sup>3</sup> )													4.37 m <sup>3</sup> (5.72 yd <sup>3</sup> )							3.80 m <sup>3</sup> (5.00 yd <sup>3</sup> )
			4.00 m <sup>3</sup> (5.25 yd <sup>3</sup> )													4.60 m <sup>3</sup> (6.02 yd <sup>3</sup> )							4.00 m <sup>3</sup> (5.25 yd <sup>3</sup> )
Aggregate Handler Package	Pin On	General Purpose	3.80 m <sup>3</sup> (5.00 yd <sup>3</sup> )											4.37 m <sup>3</sup> (5.72 yd <sup>3</sup> )								3.80 m <sup>3</sup> (5.00 yd <sup>3</sup> )	
			4.00 m <sup>3</sup> (5.25 yd <sup>3</sup> )													4.60 m <sup>3</sup> (6.02 yd <sup>3</sup> )							4.00 m <sup>3</sup> (5.25 yd <sup>3</sup> )
			4.20 m <sup>3</sup> (5.50 yd <sup>3</sup> )													4.83 m <sup>3</sup> (6.32 yd <sup>3</sup> )							4.20 m <sup>3</sup> (5.50 yd <sup>3</sup> )
	Fusion QC	General Purpose	3.80 m <sup>3</sup> (5.00 yd <sup>3</sup> )												4.37 m <sup>3</sup> (5.72 yd <sup>3</sup> )								3.80 m <sup>3</sup> (5.00 yd <sup>3</sup> )
			4.20 m <sup>3</sup> (5.50 yd <sup>3</sup> )													4.83 m <sup>3</sup> (6.32 yd <sup>3</sup> )							4.20 m <sup>3</sup> (5.50 yd <sup>3</sup> )
			4.20 m <sup>3</sup> (5.50 yd <sup>3</sup> )													4.83 m <sup>3</sup> (6.32 yd <sup>3</sup> )							4.20 m <sup>3</sup> (5.50 yd <sup>3</sup> )
	Pin On	Material Handling	4.20 m <sup>3</sup> (5.50 yd <sup>3</sup> )												4.83 m <sup>3</sup> (6.32 yd <sup>3</sup> )								4.20 m <sup>3</sup> (5.50 yd <sup>3</sup> )
			3.80 m <sup>3</sup> (5.00 yd <sup>3</sup> )													4.37 m <sup>3</sup> (5.72 yd <sup>3</sup> )							3.80 m <sup>3</sup> (5.00 yd <sup>3</sup> )
			4.00 m <sup>3</sup> (5.25 yd <sup>3</sup> )													4.60 m <sup>3</sup> (6.02 yd <sup>3</sup> )							4.00 m <sup>3</sup> (5.25 yd <sup>3</sup> )
Material Density	lb/yd <sup>3</sup>	1180	1348	1517	1685	1854	2022	2191	2359	2528	2696	2865	3033	3202	3370	3539	3707	3876	4044	4213			
Bucket Fill Factors		115% 110% 105% 100% 95% 																					

NOTE: All buckets are showing Bolt-On Edges.  
Machine and bucket availability varies by region. Contact your local Cat dealer for product availability.

**972L/972M**

Material Density		kg/m <sup>3</sup>	700	800	900	1000	1100	1200	1300	1400	1500	1600	1700	1800	1900	2000	2100	2200	2300	2400	2500		
Standard Linkage	Pin On General Purpose	4.60 m <sup>3</sup> (6.00 yd <sup>3</sup> )																					
		4.80 m <sup>3</sup> (6.25 yd <sup>3</sup> )																					
		5.00 m <sup>3</sup> (6.50 yd <sup>3</sup> )																					
Fusion OC	General Purpose	4.40 m <sup>3</sup> (5.75 yd <sup>3</sup> )																					
		4.60 m <sup>3</sup> (6.00 yd <sup>3</sup> )																					
		4.80 m <sup>3</sup> (6.25 yd <sup>3</sup> )																					
High Lift Linkage	Pin On General Purpose	4.60 m <sup>3</sup> (6.00 yd <sup>3</sup> )																					
		4.80 m <sup>3</sup> (6.25 yd <sup>3</sup> )																					
		5.00 m <sup>3</sup> (6.50 yd <sup>3</sup> )																					
Fusion OC	General Purpose	4.40 m <sup>3</sup> (5.75 yd <sup>3</sup> )																					
		4.60 m <sup>3</sup> (6.00 yd <sup>3</sup> )																					
		4.80 m <sup>3</sup> (6.25 yd <sup>3</sup> )																					
Extended Linkage	Fusion OC General Purpose	4.90 m <sup>3</sup> (6.41 yd <sup>3</sup> )																					
		5.10 m <sup>3</sup> (6.67 yd <sup>3</sup> )																					
		5.30 m <sup>3</sup> (6.93 yd <sup>3</sup> )																					
Aggregate Handler Package	Pin On General Purpose	5.10 m <sup>3</sup> (6.67 yd <sup>3</sup> )																					
		5.30 m <sup>3</sup> (6.93 yd <sup>3</sup> )																					
		5.50 m <sup>3</sup> (7.19 yd <sup>3</sup> )																					
Material Density		lb/yd <sup>3</sup>	1180	1348	1517	1685	1854	2022	2191	2359	2528	2696	2865	3033	3202	3370	3539	3707	3876	4044	4213		
Bucket Fill Factors		115% 110% 105% 100% 95%																					

**NOTE:** All buckets are showing Bolt-On Edges.  
Machine and bucket availability varies by region. Contact your local Cat dealer for product availability.

980L/980M

Material Density		kg/m <sup>3</sup>	700	800	900	1000	1100	1200	1300	1400	1500	1600	1700	1800	1900	2000	2100	2200	2300	2400	2500	
Standard Linkage	Pin On	General Purpose	5.40 m <sup>3</sup> (7.06 yd <sup>3</sup> )										6.21 m <sup>3</sup> (8.12 yd <sup>3</sup> )			5.40 m <sup>3</sup> (7.06 yd <sup>3</sup> )						
		Rock	4.40 m <sup>3</sup> (5.75 yd <sup>3</sup> )											5.06 m <sup>3</sup> (6.62 yd <sup>3</sup> )							4.40 m <sup>3</sup> (5.75 yd <sup>3</sup> )	
		Coal	8.20 m <sup>3</sup> (10.73 yd <sup>3</sup> )			9.43 m <sup>3</sup> (12.33 yd <sup>3</sup> )				8.20 m <sup>3</sup> (10.73 yd <sup>3</sup> )												
Aggregate Handler	Pin On	General Purpose	5.70 m <sup>3</sup> (7.46 yd <sup>3</sup> )										6.56 m <sup>3</sup> (8.58 yd <sup>3</sup> )								5.70 m <sup>3</sup> (7.46 yd <sup>3</sup> )	
			6.00 m <sup>3</sup> (7.85 yd <sup>3</sup> )										6.90 m <sup>3</sup> (9.025 yd <sup>3</sup> )								6.00 m <sup>3</sup> (7.85 yd <sup>3</sup> )	
	Material Handling	5.70 m <sup>3</sup> (7.46 yd <sup>3</sup> )											6.56 m <sup>3</sup> (8.58 yd <sup>3</sup> )								5.70 m <sup>3</sup> (7.46 yd <sup>3</sup> )	
	Coal	8.20 m <sup>3</sup> (10.73 yd <sup>3</sup> )			9.43 m <sup>3</sup> (12.33 yd <sup>3</sup> )				8.20 m <sup>3</sup> (10.73 yd <sup>3</sup> )													
Material Density		lb/yd <sup>3</sup>	1180	1348	1517	1685	1854	2022	2191	2359	2528	2696	2865	3033	3202	3370	3539	3707	3876	4044	4213	
Bucket Fill Factors																						
115% 110% 105% 100% 95%																						

NOTE: All buckets are showing Bolt-On Edges.  
Machine and bucket availability varies by region. Contact your local Cat dealer for product availability.

**982M**

Material Density		kg/m <sup>3</sup>	600	700	800	900	1000	1100	1200	1300	1400	1500	1600	1700	1800	1900	2000	2100	2200	2300	2400	
Standard Linkage	General Purpose	6.10 m <sup>3</sup> (7.98 yd <sup>3</sup> )																				
		6.40 m <sup>3</sup> (8.37 yd <sup>3</sup> )																				
	Heavy Duty Rock	5.40 m <sup>3</sup> (7.06 yd <sup>3</sup> )																				
	Woodchip	12.00 m <sup>3</sup> (15.70 yd <sup>3</sup> )	13.80 m <sup>3</sup> (18.05 yd <sup>3</sup> )																			
	Coal	8.80 m <sup>3</sup> (11.51 yd <sup>3</sup> )																				
Aggregate Handler	General Purpose	6.40 m <sup>3</sup> (8.37 yd <sup>3</sup> )																				
		7.00 m <sup>3</sup> (9.16 yd <sup>3</sup> )																				
		7.50 m <sup>3</sup> (9.81 yd <sup>3</sup> )																				
		8.20 m <sup>3</sup> (10.73 yd <sup>3</sup> )																				
	General Purpose – Heavy Duty	7.50 m <sup>3</sup> (9.81 yd <sup>3</sup> )																				
	Material Handler – Heavy Duty	6.40 m <sup>3</sup> (8.37 yd <sup>3</sup> )																				
		7.00 m <sup>3</sup> (9.16 yd <sup>3</sup> )																				
	Woodchip	12.00 m <sup>3</sup> (15.70 yd <sup>3</sup> )	13.80 m <sup>3</sup> (18.05 yd <sup>3</sup> )																			
Coal	8.80 m <sup>3</sup> (11.51 yd <sup>3</sup> )																					
<b>Material Density</b>	<b>lb/yd<sup>3</sup></b>		1011	1180	1348	1517	1685	1854	2022	2191	2359	2528	2696	2865	3033	3202	3370	3539	3707	3876	4044	
Bucket Fill Factors		115% 110% 105% 100% 95% 																				

**NOTE:** All buckets are showing Bolt-On Edges.  
Machine and bucket availability varies by region. Contact your local Cat dealer for product availability.

950K

Material Density		kg/m <sup>3</sup>	700	800	900	1000	1100	1200	1300	1400	1500	1600	1700	1800	1900	2000	2100	2200	2300	2400	2500			
Pin On	General Purpose	2.70 m <sup>3</sup> (3.53 yd <sup>3</sup> )													3.11 m <sup>3</sup> (4.07 yd <sup>3</sup> )							2.70 m <sup>3</sup> (3.53 yd <sup>3</sup> )		
		2.90 m <sup>3</sup> (3.79 yd <sup>3</sup> )													3.34 m <sup>3</sup> (4.37 yd <sup>3</sup> )							2.90 m <sup>3</sup> (3.79 yd <sup>3</sup> )		
		3.10 m <sup>3</sup> (4.05 yd <sup>3</sup> )													3.57 m <sup>3</sup> (4.67 yd <sup>3</sup> )							3.10 m <sup>3</sup> (4.05 yd <sup>3</sup> )		
		3.30 m <sup>3</sup> (4.32 yd <sup>3</sup> )													3.80 m <sup>3</sup> (4.97 yd <sup>3</sup> )							3.30 m <sup>3</sup> (4.32 yd <sup>3</sup> )		
		3.40 m <sup>3</sup> (4.45 yd <sup>3</sup> )													3.91 m <sup>3</sup> (5.11 yd <sup>3</sup> )							3.40 m <sup>3</sup> (4.45 yd <sup>3</sup> )		
		3.60 m <sup>3</sup> (4.71 yd <sup>3</sup> )													4.14 m <sup>3</sup> (5.41 yd <sup>3</sup> )							3.60 m <sup>3</sup> (4.71 yd <sup>3</sup> )		
		3.80 m <sup>3</sup> (4.97 yd <sup>3</sup> )													4.37 m <sup>3</sup> (5.72 yd <sup>3</sup> )							3.80 m <sup>3</sup> (4.97 yd <sup>3</sup> )		
Standard Linkage	Material Handling	2.70 m <sup>3</sup> (3.53 yd <sup>3</sup> )																					2.70 m <sup>3</sup> (3.53 yd <sup>3</sup> )	
		2.90 m <sup>3</sup> (3.79 yd <sup>3</sup> )																						2.90 m <sup>3</sup> (3.79 yd <sup>3</sup> )
		3.10 m <sup>3</sup> (4.05 yd <sup>3</sup> )																						3.10 m <sup>3</sup> (4.05 yd <sup>3</sup> )
		3.30 m <sup>3</sup> (4.32 yd <sup>3</sup> )																						3.30 m <sup>3</sup> (4.32 yd <sup>3</sup> )
		3.40 m <sup>3</sup> (4.45 yd <sup>3</sup> )																						3.40 m <sup>3</sup> (4.45 yd <sup>3</sup> )
		3.60 m <sup>3</sup> (4.71 yd <sup>3</sup> )																						3.60 m <sup>3</sup> (4.71 yd <sup>3</sup> )
		3.80 m <sup>3</sup> (4.97 yd <sup>3</sup> )																						3.80 m <sup>3</sup> (4.97 yd <sup>3</sup> )
Fusion QC	General Purpose	2.70 m <sup>3</sup> (3.53 yd <sup>3</sup> )																					2.70 m <sup>3</sup> (3.53 yd <sup>3</sup> )	
		2.90 m <sup>3</sup> (3.79 yd <sup>3</sup> )																						2.90 m <sup>3</sup> (3.79 yd <sup>3</sup> )
		3.10 m <sup>3</sup> (4.05 yd <sup>3</sup> )																						3.10 m <sup>3</sup> (4.05 yd <sup>3</sup> )
		3.30 m <sup>3</sup> (4.32 yd <sup>3</sup> )																						3.30 m <sup>3</sup> (4.32 yd <sup>3</sup> )
		3.40 m <sup>3</sup> (4.45 yd <sup>3</sup> )																						3.40 m <sup>3</sup> (4.45 yd <sup>3</sup> )
		3.60 m <sup>3</sup> (4.71 yd <sup>3</sup> )																						3.60 m <sup>3</sup> (4.71 yd <sup>3</sup> )
		3.80 m <sup>3</sup> (4.97 yd <sup>3</sup> )																						3.80 m <sup>3</sup> (4.97 yd <sup>3</sup> )
Fusion QC	Material Handling	2.70 m <sup>3</sup> (3.53 yd <sup>3</sup> )																					2.70 m <sup>3</sup> (3.53 yd <sup>3</sup> )	
		2.90 m <sup>3</sup> (3.79 yd <sup>3</sup> )																						2.90 m <sup>3</sup> (3.79 yd <sup>3</sup> )
		3.10 m <sup>3</sup> (4.05 yd <sup>3</sup> )																						3.10 m <sup>3</sup> (4.05 yd <sup>3</sup> )
		3.30 m <sup>3</sup> (4.32 yd <sup>3</sup> )																						3.30 m <sup>3</sup> (4.32 yd <sup>3</sup> )
		3.40 m <sup>3</sup> (4.45 yd <sup>3</sup> )																						3.40 m <sup>3</sup> (4.45 yd <sup>3</sup> )
		3.60 m <sup>3</sup> (4.71 yd <sup>3</sup> )																						3.60 m <sup>3</sup> (4.71 yd <sup>3</sup> )
		3.80 m <sup>3</sup> (4.97 yd <sup>3</sup> )																						3.80 m <sup>3</sup> (4.97 yd <sup>3</sup> )
Material Density	lb/yd <sup>3</sup>	1180	1348	1517	1685	1854	2022	2191	2359	2528	2696	2865	3033	3202	3370	3539	3707	3876	4044	4213				
Bucket Fill Factors 115% 110% 105% 100% 95%																								

NOTE: All buckets are showing Bolt-On Edges. Material Handling buckets are flat floor buckets. Contact your local Cat dealer for product availability.



**950K**

Material Density		kg/m <sup>3</sup>	700	800	900	1000	1100	1200	1300	1400	1500	1600	1700	1800	1900	2000	2100	2200	2300	2400	2500		
Pin On	General Purpose	2.70 m <sup>3</sup> (3.53 yd <sup>3</sup> )																					
		2.90 m <sup>3</sup> (3.79 yd <sup>3</sup> )																					
		3.10 m <sup>3</sup> (4.05 yd <sup>3</sup> )																					
		3.30 m <sup>3</sup> (4.32 yd <sup>3</sup> )																					
		3.40 m <sup>3</sup> (4.45 yd <sup>3</sup> )																					
		3.60 m <sup>3</sup> (4.71 yd <sup>3</sup> )																					
		3.80 m <sup>3</sup> (4.97 yd <sup>3</sup> )																					
		3.11 m <sup>3</sup> (4.07 yd <sup>3</sup> )																					
High Lift Linkage	Material Handling	2.70 m <sup>3</sup> (3.53 yd <sup>3</sup> )																					
		2.90 m <sup>3</sup> (3.79 yd <sup>3</sup> )																					
		3.10 m <sup>3</sup> (4.05 yd <sup>3</sup> )																					
		3.30 m <sup>3</sup> (4.32 yd <sup>3</sup> )																					
		3.40 m <sup>3</sup> (4.45 yd <sup>3</sup> )																					
		3.60 m <sup>3</sup> (4.71 yd <sup>3</sup> )																					
		3.80 m <sup>3</sup> (4.97 yd <sup>3</sup> )																					
		3.11 m <sup>3</sup> (4.07 yd <sup>3</sup> )																					
Fusion QC	General Purpose	2.70 m <sup>3</sup> (3.53 yd <sup>3</sup> )																					
		2.90 m <sup>3</sup> (3.79 yd <sup>3</sup> )																					
		3.10 m <sup>3</sup> (4.05 yd <sup>3</sup> )																					
		3.30 m <sup>3</sup> (4.32 yd <sup>3</sup> )																					
		3.40 m <sup>3</sup> (4.45 yd <sup>3</sup> )																					
		3.60 m <sup>3</sup> (4.71 yd <sup>3</sup> )																					
		3.80 m <sup>3</sup> (4.97 yd <sup>3</sup> )																					
		3.11 m <sup>3</sup> (4.07 yd <sup>3</sup> )																					
Fusion QC	Material Handling	2.70 m <sup>3</sup> (3.53 yd <sup>3</sup> )																					
		2.90 m <sup>3</sup> (3.79 yd <sup>3</sup> )																					
		3.10 m <sup>3</sup> (4.05 yd <sup>3</sup> )																					
		3.30 m <sup>3</sup> (4.32 yd <sup>3</sup> )																					
		3.40 m <sup>3</sup> (4.45 yd <sup>3</sup> )																					
		3.60 m <sup>3</sup> (4.71 yd <sup>3</sup> )																					
		3.80 m <sup>3</sup> (4.97 yd <sup>3</sup> )																					
		3.11 m <sup>3</sup> (4.07 yd <sup>3</sup> )																					
Material Density	lb/yd <sup>3</sup>	1180	1348	1517	1685	1854	2022	2191	2359	2528	2696	2865	3033	3202	3370	3539	3707	3876	4044	4213			
Bucket Fill Factors		<div style="display: flex; justify-content: space-between;"> <span>115%</span> <span>110%</span> <span>105%</span> <span>100%</span> <span>95%</span> </div>																					

**NOTE:** All buckets are showing Bolt-On Edges. Material Handling buckets are flat floor buckets.  
Contact your local Cat dealer for product availability.

950K

Material Density		kg/m <sup>3</sup>	700	800	900	1000	1100	1200	1300	1400	1500	1600	1700	1800	1900	2000	2100	2200	2300	2400	2500	
Power Package	Pin On	General Purpose	2.70 m <sup>3</sup> (3.53 yd <sup>3</sup> )													3.11 m <sup>3</sup> (4.07 yd <sup>3</sup> )					2.70 m <sup>3</sup> (3.53 yd <sup>3</sup> )	
			2.90 m <sup>3</sup> (3.79 yd <sup>3</sup> )													3.34 m <sup>3</sup> (4.37 yd <sup>3</sup> )					2.90 m <sup>3</sup> (3.79 yd <sup>3</sup> )	
			3.10 m <sup>3</sup> (4.05 yd <sup>3</sup> )													3.57 m <sup>3</sup> (4.67 yd <sup>3</sup> )					3.10 m <sup>3</sup> (4.05 yd <sup>3</sup> )	
			3.30 m <sup>3</sup> (4.32 yd <sup>3</sup> )													3.80 m <sup>3</sup> (4.97 yd <sup>3</sup> )					3.30 m <sup>3</sup> (4.32 yd <sup>3</sup> )	
			3.40 m <sup>3</sup> (4.45 yd <sup>3</sup> )													3.91 m <sup>3</sup> (5.11 yd <sup>3</sup> )					3.40 m <sup>3</sup> (4.45 yd <sup>3</sup> )	
			3.60 m <sup>3</sup> (4.71 yd <sup>3</sup> )													4.14 m <sup>3</sup> (5.41 yd <sup>3</sup> )					3.60 m <sup>3</sup> (4.71 yd <sup>3</sup> )	
			3.80 m <sup>3</sup> (4.97 yd <sup>3</sup> )													4.37 m <sup>3</sup> (5.72 yd <sup>3</sup> )					3.80 m <sup>3</sup> (4.97 yd <sup>3</sup> )	
	Material Handling	2.70 m <sup>3</sup> (3.53 yd <sup>3</sup> )															3.11 m <sup>3</sup> (4.07 yd <sup>3</sup> )					2.70 m <sup>3</sup> (3.53 yd <sup>3</sup> )
		2.90 m <sup>3</sup> (3.79 yd <sup>3</sup> )															3.34 m <sup>3</sup> (4.37 yd <sup>3</sup> )					2.90 m <sup>3</sup> (3.79 yd <sup>3</sup> )
		3.10 m <sup>3</sup> (4.05 yd <sup>3</sup> )															3.57 m <sup>3</sup> (4.67 yd <sup>3</sup> )					3.10 m <sup>3</sup> (4.05 yd <sup>3</sup> )
		3.30 m <sup>3</sup> (4.32 yd <sup>3</sup> )															3.80 m <sup>3</sup> (4.97 yd <sup>3</sup> )					3.30 m <sup>3</sup> (4.32 yd <sup>3</sup> )
		3.40 m <sup>3</sup> (4.45 yd <sup>3</sup> )															3.91 m <sup>3</sup> (5.11 yd <sup>3</sup> )					3.40 m <sup>3</sup> (4.45 yd <sup>3</sup> )
		3.60 m <sup>3</sup> (4.71 yd <sup>3</sup> )															4.14 m <sup>3</sup> (5.41 yd <sup>3</sup> )					3.60 m <sup>3</sup> (4.71 yd <sup>3</sup> )
		3.80 m <sup>3</sup> (4.97 yd <sup>3</sup> )															4.37 m <sup>3</sup> (5.72 yd <sup>3</sup> )					3.80 m <sup>3</sup> (4.97 yd <sup>3</sup> )
Fusion QC	General Purpose	2.70 m <sup>3</sup> (3.53 yd <sup>3</sup> )														3.11 m <sup>3</sup> (4.07 yd <sup>3</sup> )					2.70 m <sup>3</sup> (3.53 yd <sup>3</sup> )	
		2.90 m <sup>3</sup> (3.79 yd <sup>3</sup> )															3.34 m <sup>3</sup> (4.37 yd <sup>3</sup> )					2.90 m <sup>3</sup> (3.79 yd <sup>3</sup> )
		3.10 m <sup>3</sup> (4.05 yd <sup>3</sup> )															3.57 m <sup>3</sup> (4.67 yd <sup>3</sup> )					3.10 m <sup>3</sup> (4.05 yd <sup>3</sup> )
		3.30 m <sup>3</sup> (4.32 yd <sup>3</sup> )															3.80 m <sup>3</sup> (4.97 yd <sup>3</sup> )					3.30 m <sup>3</sup> (4.32 yd <sup>3</sup> )
		3.40 m <sup>3</sup> (4.45 yd <sup>3</sup> )															3.91 m <sup>3</sup> (5.11 yd <sup>3</sup> )					3.40 m <sup>3</sup> (4.45 yd <sup>3</sup> )
		3.60 m <sup>3</sup> (4.71 yd <sup>3</sup> )															4.14 m <sup>3</sup> (5.41 yd <sup>3</sup> )					3.60 m <sup>3</sup> (4.71 yd <sup>3</sup> )
		3.80 m <sup>3</sup> (4.97 yd <sup>3</sup> )															4.37 m <sup>3</sup> (5.72 yd <sup>3</sup> )					3.80 m <sup>3</sup> (4.97 yd <sup>3</sup> )
Material Handling	2.70 m <sup>3</sup> (3.53 yd <sup>3</sup> )															3.11 m <sup>3</sup> (4.07 yd <sup>3</sup> )					2.70 m <sup>3</sup> (3.53 yd <sup>3</sup> )	
	2.90 m <sup>3</sup> (3.79 yd <sup>3</sup> )															3.34 m <sup>3</sup> (4.37 yd <sup>3</sup> )					2.90 m <sup>3</sup> (3.79 yd <sup>3</sup> )	
	3.10 m <sup>3</sup> (4.05 yd <sup>3</sup> )															3.57 m <sup>3</sup> (4.67 yd <sup>3</sup> )					3.10 m <sup>3</sup> (4.05 yd <sup>3</sup> )	
	3.30 m <sup>3</sup> (4.32 yd <sup>3</sup> )															3.80 m <sup>3</sup> (4.97 yd <sup>3</sup> )					3.30 m <sup>3</sup> (4.32 yd <sup>3</sup> )	
	3.40 m <sup>3</sup> (4.45 yd <sup>3</sup> )															3.91 m <sup>3</sup> (5.11 yd <sup>3</sup> )					3.40 m <sup>3</sup> (4.45 yd <sup>3</sup> )	
	3.60 m <sup>3</sup> (4.71 yd <sup>3</sup> )															4.14 m <sup>3</sup> (5.41 yd <sup>3</sup> )					3.60 m <sup>3</sup> (4.71 yd <sup>3</sup> )	
	3.80 m <sup>3</sup> (4.97 yd <sup>3</sup> )															4.37 m <sup>3</sup> (5.72 yd <sup>3</sup> )					3.80 m <sup>3</sup> (4.97 yd <sup>3</sup> )	
Material Density	lb/yd <sup>3</sup>	1180	1348	1517	1685	1854	2022	2191	2359	2528	2696	2865	3033	3202	3370	3539	3707	3876	4044	4213		
Bucket Fill Factors 115% 110% 105% 100% 95%																						

NOTE: All buckets are showing Bolt-On Edges. Material Handling buckets are flat floor buckets. Contact your local Cat dealer for product availability.

### 962K

Material Density		kg/m <sup>3</sup>	700	800	900	1000	1100	1200	1300	1400	1500	1600	1700	1800	1900	2000	2100	2200	2300	2400	2500		
Pin On	General Purpose	2.70 m <sup>3</sup> (3.53 yd <sup>3</sup> )																					
		2.90 m <sup>3</sup> (3.79 yd <sup>3</sup> )																					
		3.10 m <sup>3</sup> (4.05 yd <sup>3</sup> )																					
		3.30 m <sup>3</sup> (4.32 yd <sup>3</sup> )																					
		3.40 m <sup>3</sup> (4.45 yd <sup>3</sup> )																					
		3.60 m <sup>3</sup> (4.71 yd <sup>3</sup> )																					
		3.80 m <sup>3</sup> (4.97 yd <sup>3</sup> )																					
	Material Handling	2.70 m <sup>3</sup> (3.53 yd <sup>3</sup> )																					
		2.90 m <sup>3</sup> (3.79 yd <sup>3</sup> )																					
		3.10 m <sup>3</sup> (4.05 yd <sup>3</sup> )																					
		3.30 m <sup>3</sup> (4.32 yd <sup>3</sup> )																					
		3.40 m <sup>3</sup> (4.45 yd <sup>3</sup> )																					
		3.60 m <sup>3</sup> (4.71 yd <sup>3</sup> )																					
		3.80 m <sup>3</sup> (4.97 yd <sup>3</sup> )																					
Standard Linkage	General Purpose	2.70 m <sup>3</sup> (3.53 yd <sup>3</sup> )																					
		2.90 m <sup>3</sup> (3.79 yd <sup>3</sup> )																					
		3.10 m <sup>3</sup> (4.05 yd <sup>3</sup> )																					
		3.30 m <sup>3</sup> (4.32 yd <sup>3</sup> )																					
		3.40 m <sup>3</sup> (4.45 yd <sup>3</sup> )																					
		3.60 m <sup>3</sup> (4.71 yd <sup>3</sup> )																					
		3.80 m <sup>3</sup> (4.97 yd <sup>3</sup> )																					
	Material Handling	2.70 m <sup>3</sup> (3.53 yd <sup>3</sup> )																					
		2.90 m <sup>3</sup> (3.79 yd <sup>3</sup> )																					
		3.10 m <sup>3</sup> (4.05 yd <sup>3</sup> )																					
		3.30 m <sup>3</sup> (4.32 yd <sup>3</sup> )																					
		3.40 m <sup>3</sup> (4.45 yd <sup>3</sup> )																					
		3.60 m <sup>3</sup> (4.71 yd <sup>3</sup> )																					
		3.80 m <sup>3</sup> (4.97 yd <sup>3</sup> )																					
Fusion QC	General Purpose	2.70 m <sup>3</sup> (3.53 yd <sup>3</sup> )																					
		2.90 m <sup>3</sup> (3.79 yd <sup>3</sup> )																					
		3.10 m <sup>3</sup> (4.05 yd <sup>3</sup> )																					
		3.30 m <sup>3</sup> (4.32 yd <sup>3</sup> )																					
		3.40 m <sup>3</sup> (4.45 yd <sup>3</sup> )																					
		3.60 m <sup>3</sup> (4.71 yd <sup>3</sup> )																					
		3.80 m <sup>3</sup> (4.97 yd <sup>3</sup> )																					
	Material Handling	2.70 m <sup>3</sup> (3.53 yd <sup>3</sup> )																					
		2.90 m <sup>3</sup> (3.79 yd <sup>3</sup> )																					
		3.10 m <sup>3</sup> (4.05 yd <sup>3</sup> )																					
		3.30 m <sup>3</sup> (4.32 yd <sup>3</sup> )																					
		3.40 m <sup>3</sup> (4.45 yd <sup>3</sup> )																					
		3.60 m <sup>3</sup> (4.71 yd <sup>3</sup> )																					
		3.80 m <sup>3</sup> (4.97 yd <sup>3</sup> )																					
Material Density	lb/yd <sup>3</sup>	1180	1348	1517	1685	1854	2022	2191	2359	2528	2696	2865	3033	3202	3370	3539	3707	3876	4044	4213			
Bucket Fill Factors																							
115% 110% 105% 100% 95%																							

**NOTE:** All buckets are showing Bolt-On Edges. Material Handling buckets are flat floor buckets.  
Contact your local Cat dealer for product availability.

962K

Material Density		kg/m <sup>3</sup>	700	800	900	1000	1100	1200	1300	1400	1500	1600	1700	1800	1900	2000	2100	2200	2300	2400	2500	
High Lift Linkage	Pin On	General Purpose	2.70 m <sup>3</sup> (3.53 yd <sup>3</sup> )												3.11 m <sup>3</sup> (4.07 yd <sup>3</sup> )						2.70 m <sup>3</sup> (3.53 yd <sup>3</sup> )	
			2.90 m <sup>3</sup> (3.79 yd <sup>3</sup> )												3.34 m <sup>3</sup> (4.37 yd <sup>3</sup> )						2.90 m <sup>3</sup> (3.79 yd <sup>3</sup> )	
			3.10 m <sup>3</sup> (4.05 yd <sup>3</sup> )												3.57 m <sup>3</sup> (4.67 yd <sup>3</sup> )						3.10 m <sup>3</sup> (4.05 yd <sup>3</sup> )	
			3.30 m <sup>3</sup> (4.32 yd <sup>3</sup> )												3.80 m <sup>3</sup> (4.97 yd <sup>3</sup> )						3.30 m <sup>3</sup> (4.32 yd <sup>3</sup> )	
			3.40 m <sup>3</sup> (4.45 yd <sup>3</sup> )												3.91 m <sup>3</sup> (5.11 yd <sup>3</sup> )						3.40 m <sup>3</sup> (4.45 yd <sup>3</sup> )	
			3.60 m <sup>3</sup> (4.71 yd <sup>3</sup> )												4.14 m <sup>3</sup> (5.41 yd <sup>3</sup> )						3.60 m <sup>3</sup> (4.71 yd <sup>3</sup> )	
			3.80 m <sup>3</sup> (4.97 yd <sup>3</sup> )												4.37 m <sup>3</sup> (5.72 yd <sup>3</sup> )						3.80 m <sup>3</sup> (4.97 yd <sup>3</sup> )	
	Material Handling	2.70 m <sup>3</sup> (3.53 yd <sup>3</sup> )														3.11 m <sup>3</sup> (4.07 yd <sup>3</sup> )						2.70 m <sup>3</sup> (3.53 yd <sup>3</sup> )
		2.90 m <sup>3</sup> (3.79 yd <sup>3</sup> )														3.34 m <sup>3</sup> (4.37 yd <sup>3</sup> )						2.90 m <sup>3</sup> (3.79 yd <sup>3</sup> )
		3.10 m <sup>3</sup> (4.05 yd <sup>3</sup> )														3.57 m <sup>3</sup> (4.67 yd <sup>3</sup> )						3.10 m <sup>3</sup> (4.05 yd <sup>3</sup> )
		3.30 m <sup>3</sup> (4.32 yd <sup>3</sup> )														3.80 m <sup>3</sup> (4.97 yd <sup>3</sup> )						3.30 m <sup>3</sup> (4.32 yd <sup>3</sup> )
		3.40 m <sup>3</sup> (4.45 yd <sup>3</sup> )														3.91 m <sup>3</sup> (5.11 yd <sup>3</sup> )						3.40 m <sup>3</sup> (4.45 yd <sup>3</sup> )
		3.60 m <sup>3</sup> (4.71 yd <sup>3</sup> )														4.14 m <sup>3</sup> (5.41 yd <sup>3</sup> )						3.60 m <sup>3</sup> (4.71 yd <sup>3</sup> )
		3.80 m <sup>3</sup> (4.97 yd <sup>3</sup> )														4.37 m <sup>3</sup> (5.72 yd <sup>3</sup> )						3.80 m <sup>3</sup> (4.97 yd <sup>3</sup> )
Fusion QC	General Purpose	2.70 m <sup>3</sup> (3.53 yd <sup>3</sup> )													3.11 m <sup>3</sup> (4.07 yd <sup>3</sup> )						2.70 m <sup>3</sup> (3.53 yd <sup>3</sup> )	
		2.90 m <sup>3</sup> (3.79 yd <sup>3</sup> )														3.34 m <sup>3</sup> (4.37 yd <sup>3</sup> )						2.90 m <sup>3</sup> (3.79 yd <sup>3</sup> )
		3.10 m <sup>3</sup> (4.05 yd <sup>3</sup> )														3.57 m <sup>3</sup> (4.67 yd <sup>3</sup> )						3.10 m <sup>3</sup> (4.05 yd <sup>3</sup> )
		3.30 m <sup>3</sup> (4.32 yd <sup>3</sup> )														3.80 m <sup>3</sup> (4.97 yd <sup>3</sup> )						3.30 m <sup>3</sup> (4.32 yd <sup>3</sup> )
		3.40 m <sup>3</sup> (4.45 yd <sup>3</sup> )														3.91 m <sup>3</sup> (5.11 yd <sup>3</sup> )						3.40 m <sup>3</sup> (4.45 yd <sup>3</sup> )
		3.60 m <sup>3</sup> (4.71 yd <sup>3</sup> )														4.14 m <sup>3</sup> (5.41 yd <sup>3</sup> )						3.60 m <sup>3</sup> (4.71 yd <sup>3</sup> )
		3.80 m <sup>3</sup> (4.97 yd <sup>3</sup> )														4.37 m <sup>3</sup> (5.72 yd <sup>3</sup> )						3.80 m <sup>3</sup> (4.97 yd <sup>3</sup> )
Material Handling	2.70 m <sup>3</sup> (3.53 yd <sup>3</sup> )														3.11 m <sup>3</sup> (4.07 yd <sup>3</sup> )						2.70 m <sup>3</sup> (3.53 yd <sup>3</sup> )	
	2.90 m <sup>3</sup> (3.79 yd <sup>3</sup> )														3.34 m <sup>3</sup> (4.37 yd <sup>3</sup> )						2.90 m <sup>3</sup> (3.79 yd <sup>3</sup> )	
	3.10 m <sup>3</sup> (4.05 yd <sup>3</sup> )														3.57 m <sup>3</sup> (4.67 yd <sup>3</sup> )						3.10 m <sup>3</sup> (4.05 yd <sup>3</sup> )	
	3.30 m <sup>3</sup> (4.32 yd <sup>3</sup> )														3.80 m <sup>3</sup> (4.97 yd <sup>3</sup> )						3.30 m <sup>3</sup> (4.32 yd <sup>3</sup> )	
	3.40 m <sup>3</sup> (4.45 yd <sup>3</sup> )														3.91 m <sup>3</sup> (5.11 yd <sup>3</sup> )						3.40 m <sup>3</sup> (4.45 yd <sup>3</sup> )	
	3.60 m <sup>3</sup> (4.71 yd <sup>3</sup> )														4.14 m <sup>3</sup> (5.41 yd <sup>3</sup> )						3.60 m <sup>3</sup> (4.71 yd <sup>3</sup> )	
	3.80 m <sup>3</sup> (4.97 yd <sup>3</sup> )														4.37 m <sup>3</sup> (5.72 yd <sup>3</sup> )						3.80 m <sup>3</sup> (4.97 yd <sup>3</sup> )	
Material Density	lb/yd <sup>3</sup>	1180	1348	1517	1685	1854	2022	2191	2359	2528	2696	2865	3033	3202	3370	3539	3707	3876	4044	4213		
Bucket Fill Factors																						

NOTE: All buckets are showing Bolt-On Edges. Material Handling buckets are flat floor buckets. Contact your local Cat dealer for product availability.

## 966K

Material Density		kg/m <sup>3</sup>	700	800	900	1000	1100	1200	1300	1400	1500	1600	1700	1800	1900	2000	2100	2200	2300	2400	2500			
Standard Linkage	Pin On	General Purpose	3.80 m <sup>3</sup> (4.97 yd <sup>3</sup> )											4.37 m <sup>3</sup> (5.72 yd <sup>3</sup> )							3.80 m <sup>3</sup> (4.97 yd <sup>3</sup> )			
			4.00 m <sup>3</sup> (5.23 yd <sup>3</sup> )											4.60 m <sup>3</sup> (6.02 yd <sup>3</sup> )								4.00 m <sup>3</sup> (5.23 yd <sup>3</sup> )		
			4.20 m <sup>3</sup> (5.49 yd <sup>3</sup> )											4.83 m <sup>3</sup> (6.32 yd <sup>3</sup> )								4.20 m <sup>3</sup> (5.49 yd <sup>3</sup> )		
			4.60 m <sup>3</sup> (6.02 yd <sup>3</sup> )									5.29 m <sup>3</sup> (6.92 yd <sup>3</sup> )											4.60 m <sup>3</sup> (6.02 yd <sup>3</sup> )	
	Fusion OC	General Purpose	3.80 m <sup>3</sup> (4.97 yd <sup>3</sup> )												4.37 m <sup>3</sup> (5.72 yd <sup>3</sup> )							3.80 m <sup>3</sup> (4.97 yd <sup>3</sup> )		
			4.20 m <sup>3</sup> (5.49 yd <sup>3</sup> )												4.83 m <sup>3</sup> (6.32 yd <sup>3</sup> )							4.20 m <sup>3</sup> (5.49 yd <sup>3</sup> )		
			4.60 m <sup>3</sup> (6.02 yd <sup>3</sup> )										5.29 m <sup>3</sup> (6.92 yd <sup>3</sup> )										4.60 m <sup>3</sup> (6.02 yd <sup>3</sup> )	
			7.10 m <sup>3</sup> (9.29 yd <sup>3</sup> )	8.17 m <sup>3</sup> (10.69 yd <sup>3</sup> )																				7.10 m <sup>3</sup> (9.29 yd <sup>3</sup> )
	Pin On	Material Handling	4.20 m <sup>3</sup> (5.49 yd <sup>3</sup> )												4.83 m <sup>3</sup> (6.32 yd <sup>3</sup> )							4.20 m <sup>3</sup> (5.49 yd <sup>3</sup> )		
			3.40 m <sup>3</sup> (4.45 yd <sup>3</sup> )												3.91 m <sup>3</sup> (5.11 yd <sup>3</sup> )							3.40 m <sup>3</sup> (4.45 yd <sup>3</sup> )		
			7.10 m <sup>3</sup> (9.29 yd <sup>3</sup> )	8.17 m <sup>3</sup> (10.69 yd <sup>3</sup> )																				7.10 m <sup>3</sup> (9.29 yd <sup>3</sup> )
			Fusion OC	General Purpose	3.80 m <sup>3</sup> (4.97 yd <sup>3</sup> )												4.37 m <sup>3</sup> (5.72 yd <sup>3</sup> )							3.80 m <sup>3</sup> (4.97 yd <sup>3</sup> )
4.20 m <sup>3</sup> (5.49 yd <sup>3</sup> )														4.83 m <sup>3</sup> (6.32 yd <sup>3</sup> )							4.20 m <sup>3</sup> (5.49 yd <sup>3</sup> )			
4.60 m <sup>3</sup> (6.02 yd <sup>3</sup> )													5.29 m <sup>3</sup> (6.92 yd <sup>3</sup> )									4.60 m <sup>3</sup> (6.02 yd <sup>3</sup> )		
7.10 m <sup>3</sup> (9.29 yd <sup>3</sup> )	8.17 m <sup>3</sup> (10.69 yd <sup>3</sup> )																						7.10 m <sup>3</sup> (9.29 yd <sup>3</sup> )	
Pin On	Material Handling	4.20 m <sup>3</sup> (5.49 yd <sup>3</sup> )												4.83 m <sup>3</sup> (6.32 yd <sup>3</sup> )							4.20 m <sup>3</sup> (5.49 yd <sup>3</sup> )			
		3.40 m <sup>3</sup> (4.45 yd <sup>3</sup> )												3.91 m <sup>3</sup> (5.11 yd <sup>3</sup> )							3.40 m <sup>3</sup> (4.45 yd <sup>3</sup> )			
		7.10 m <sup>3</sup> (9.29 yd <sup>3</sup> )	8.17 m <sup>3</sup> (10.69 yd <sup>3</sup> )																				7.10 m <sup>3</sup> (9.29 yd <sup>3</sup> )	
		Fusion OC	General Purpose	3.80 m <sup>3</sup> (4.97 yd <sup>3</sup> )												4.37 m <sup>3</sup> (5.72 yd <sup>3</sup> )							3.80 m <sup>3</sup> (4.97 yd <sup>3</sup> )	
4.20 m <sup>3</sup> (5.49 yd <sup>3</sup> )														4.83 m <sup>3</sup> (6.32 yd <sup>3</sup> )							4.20 m <sup>3</sup> (5.49 yd <sup>3</sup> )			
4.60 m <sup>3</sup> (6.02 yd <sup>3</sup> )													5.29 m <sup>3</sup> (6.92 yd <sup>3</sup> )									4.60 m <sup>3</sup> (6.02 yd <sup>3</sup> )		
7.10 m <sup>3</sup> (9.29 yd <sup>3</sup> )	8.17 m <sup>3</sup> (10.69 yd <sup>3</sup> )																						7.10 m <sup>3</sup> (9.29 yd <sup>3</sup> )	
Material Density		lb/yd <sup>3</sup>	1180	1348	1517	1685	1854	2022	2191	2359	2528	2696	2865	3033	3202	3370	3539	3707	3876	4044	4213			
Bucket Fill Factors		115% 110% 105% 100% 95%																						

**NOTE:** All buckets are showing Bolt-On Edges. Material Handling buckets are flat floor buckets. Contact your local Cat dealer for product availability.

972K

Material Density		kg/m <sup>3</sup>	700	800	900	1000	1100	1200	1300	1400	1500	1600	1700	1800	1900	2000	2100	2200	2300	2400	2500	
Standard Linkage	Pin On	General Purpose	4.20 m <sup>3</sup> (5.49 yd <sup>3</sup> )											4.83 m <sup>3</sup> (6.32 yd <sup>3</sup> )							4.20 m <sup>3</sup> (5.49 yd <sup>3</sup> )	
			4.40 m <sup>3</sup> (5.75 yd <sup>3</sup> )												5.06 m <sup>3</sup> (6.62 yd <sup>3</sup> )							4.40 m <sup>3</sup> (5.75 yd <sup>3</sup> )
			4.60 m <sup>3</sup> (6.02 yd <sup>3</sup> )												5.29 m <sup>3</sup> (6.92 yd <sup>3</sup> )							4.60 m <sup>3</sup> (6.02 yd <sup>3</sup> )
			4.80 m <sup>3</sup> (6.28 yd <sup>3</sup> )												5.52 m <sup>3</sup> (7.22 yd <sup>3</sup> )							4.80 m <sup>3</sup> (6.28 yd <sup>3</sup> )
			5.00 m <sup>3</sup> (6.54 yd <sup>3</sup> )												5.75 m <sup>3</sup> (7.52 yd <sup>3</sup> )							5.00 m <sup>3</sup> (6.54 yd <sup>3</sup> )
	Fusion OC	Material Handling	4.60 m <sup>3</sup> (6.02 yd <sup>3</sup> )												5.29 m <sup>3</sup> (6.92 yd <sup>3</sup> )							4.60 m <sup>3</sup> (6.02 yd <sup>3</sup> )
			3.60 m <sup>3</sup> (4.71 yd <sup>3</sup> )													4.14 m <sup>3</sup> (5.42 yd <sup>3</sup> )						
		Rock	4.00 m <sup>3</sup> (5.23 yd <sup>3</sup> )												4.60 m <sup>3</sup> (6.02 yd <sup>3</sup> )							3.80 m <sup>3</sup> (4.97 yd <sup>3</sup> )
			7.10 m <sup>3</sup> (9.29 yd <sup>3</sup> )				8.17 m <sup>3</sup> (10.69 yd <sup>3</sup> )									7.10 m <sup>3</sup> (9.29 yd <sup>3</sup> )						
		Fusion OC	General Purpose	4.20 m <sup>3</sup> (5.49 yd <sup>3</sup> )												4.83 m <sup>3</sup> (6.32 yd <sup>3</sup> )						
4.40 m <sup>3</sup> (5.75 yd <sup>3</sup> )														5.06 m <sup>3</sup> (6.62 yd <sup>3</sup> )							4.40 m <sup>3</sup> (5.75 yd <sup>3</sup> )	
4.60 m <sup>3</sup> (6.02 yd <sup>3</sup> )														5.29 m <sup>3</sup> (6.92 yd <sup>3</sup> )							4.60 m <sup>3</sup> (6.02 yd <sup>3</sup> )	
4.80 m <sup>3</sup> (6.28 yd <sup>3</sup> )														5.52 m <sup>3</sup> (7.22 yd <sup>3</sup> )							4.80 m <sup>3</sup> (6.28 yd <sup>3</sup> )	
5.00 m <sup>3</sup> (6.54 yd <sup>3</sup> )														5.75 m <sup>3</sup> (7.52 yd <sup>3</sup> )							5.00 m <sup>3</sup> (6.54 yd <sup>3</sup> )	
Rock	3.60 m <sup>3</sup> (4.71 yd <sup>3</sup> )													4.14 m <sup>3</sup> (5.42 yd <sup>3</sup> )							3.42 m <sup>3</sup> (4.47 yd <sup>3</sup> )	
	7.10 m <sup>3</sup> (9.29 yd <sup>3</sup> )				8.17 m <sup>3</sup> (10.69 yd <sup>3</sup> )									7.10 m <sup>3</sup> (9.29 yd <sup>3</sup> )								
Material Density		lb/yd <sup>3</sup>	1180	1348	1517	1685	1854	2022	2191	2359	2528	2696	2865	3033	3202	3370	3539	3707	3876	4044	4213	
Bucket Fill Factors																						
115% 110% 105% 100% 95%																						

NOTE: All buckets are showing Bolt-On Edges. Material Handling buckets are flat floor buckets. Contact your local Cat dealer for product availability.

## 972K

Material Density		kg/m <sup>3</sup>	700	800	900	1000	1100	1200	1300	1400	1500	1600	1700	1800	1900	2000	2100	2200	2300	2400	2500			
High Lift Linkage	Pin On	General Purpose	4.20 m <sup>3</sup> (5.49 yd <sup>3</sup> )											4.83 m <sup>3</sup> (6.32 yd <sup>3</sup> )								4.20 m <sup>3</sup> (5.49 yd <sup>3</sup> )		
			4.40 m <sup>3</sup> (5.75 yd <sup>3</sup> )												5.06 m <sup>3</sup> (6.62 yd <sup>3</sup> )								4.40 m <sup>3</sup> (5.75 yd <sup>3</sup> )	
			4.60 m <sup>3</sup> (6.02 yd <sup>3</sup> )												5.29 m <sup>3</sup> (6.92 yd <sup>3</sup> )								4.60 m <sup>3</sup> (6.02 yd <sup>3</sup> )	
			4.80 m <sup>3</sup> (6.28 yd <sup>3</sup> )												5.52 m <sup>3</sup> (7.22 yd <sup>3</sup> )								4.80 m <sup>3</sup> (6.28 yd <sup>3</sup> )	
			5.00 m <sup>3</sup> (6.54 yd <sup>3</sup> )												5.75 m <sup>3</sup> (7.52 yd <sup>3</sup> )								5.00 m <sup>3</sup> (6.54 yd <sup>3</sup> )	
	Fusion OC	Material Handling	4.60 m <sup>3</sup> (6.02 yd <sup>3</sup> )												5.29 m <sup>3</sup> (6.92 yd <sup>3</sup> )								4.60 m <sup>3</sup> (6.02 yd <sup>3</sup> )	
			3.60 m <sup>3</sup> (4.71 yd <sup>3</sup> )													4.14 m <sup>3</sup> (5.42 yd <sup>3</sup> )							3.42 m <sup>3</sup> (4.47 yd <sup>3</sup> )	
		Rock	4.00 m <sup>3</sup> (5.23 yd <sup>3</sup> )													4.60 m <sup>3</sup> (6.02 yd <sup>3</sup> )								3.80 m <sup>3</sup> (4.97 yd <sup>3</sup> )
			7.10 m <sup>3</sup> (9.29 yd <sup>3</sup> )																					
		Fusion OC	General Purpose	4.20 m <sup>3</sup> (5.49 yd <sup>3</sup> )													4.83 m <sup>3</sup> (6.32 yd <sup>3</sup> )							
4.40 m <sup>3</sup> (5.75 yd <sup>3</sup> )															5.06 m <sup>3</sup> (6.62 yd <sup>3</sup> )								4.40 m <sup>3</sup> (5.75 yd <sup>3</sup> )	
4.60 m <sup>3</sup> (6.02 yd <sup>3</sup> )															5.29 m <sup>3</sup> (6.92 yd <sup>3</sup> )								4.60 m <sup>3</sup> (6.02 yd <sup>3</sup> )	
4.80 m <sup>3</sup> (6.28 yd <sup>3</sup> )															5.52 m <sup>3</sup> (7.22 yd <sup>3</sup> )								4.80 m <sup>3</sup> (6.28 yd <sup>3</sup> )	
5.00 m <sup>3</sup> (6.54 yd <sup>3</sup> )															5.75 m <sup>3</sup> (7.52 yd <sup>3</sup> )								5.00 m <sup>3</sup> (6.54 yd <sup>3</sup> )	
Material Handling	3.60 m <sup>3</sup> (4.71 yd <sup>3</sup> )														4.14 m <sup>3</sup> (5.42 yd <sup>3</sup> )								3.42 m <sup>3</sup> (4.47 yd <sup>3</sup> )	
	7.10 m <sup>3</sup> (9.29 yd <sup>3</sup> )																						7.10 m <sup>3</sup> (9.29 yd <sup>3</sup> )	
Material Density	lb/yd <sup>3</sup>	1180	1348	1517	1685	1854	2022	2191	2359	2528	2696	2865	3033	3202	3370	3539	3707	3876	4044	4213				
Bucket Fill Factors		115% 110% 105% 100% 95% 																						

Material Density		kg/m <sup>3</sup>	700	800	900	1000	1100	1200	1300	1400	1500	1600	1700	1800	1900	2000	2100	2200	2300	2400	2500												
Extended Capacity Linkage	Pin On	General Purpose	4.60 m <sup>3</sup> (6.02 yd <sup>3</sup> )																				5.29 m <sup>3</sup> (6.92 yd <sup>3</sup> )								4.60 m <sup>3</sup> (6.02 yd <sup>3</sup> )		
			4.90 m <sup>3</sup> (6.41 yd <sup>3</sup> )																							5.64 m <sup>3</sup> (7.38 yd <sup>3</sup> )							4.90 m <sup>3</sup> (6.41 yd <sup>3</sup> )
	Fusion OC	General Purpose	4.60 m <sup>3</sup> (6.02 yd <sup>3</sup> )																							5.29 m <sup>3</sup> (6.92 yd <sup>3</sup> )							4.60 m <sup>3</sup> (6.02 yd <sup>3</sup> )
			4.90 m <sup>3</sup> (6.41 yd <sup>3</sup> )																								5.64 m <sup>3</sup> (7.38 yd <sup>3</sup> )						
Material Density	lb/yd <sup>3</sup>	1180	1348	1517	1685	1854	2022	2191	2359	2528	2696	2865	3033	3202	3370	3539	3707	3876	4044	4213													
Bucket Fill Factors		115% 110% 105% 100% 95% 																															

**NOTE:** All buckets are showing Bolt-On Edges. Material Handling buckets are flat floor buckets. Contact your local Cat dealer for product availability.

980K

Material Density		kg/m <sup>3</sup>	700	800	900	1000	1100	1200	1300	1400	1500	1600	1700	1800	1900	2000	2100	2200	2300	2400	2500	
Standard Linkage	Pin On	General Purpose	5.40 m <sup>3</sup> (7.06 yd <sup>3</sup> )									6.21 m <sup>3</sup> (8.12 yd <sup>3</sup> )			5.40 m <sup>3</sup> (7.06 yd <sup>3</sup> )							
		Rock	4.40 m <sup>3</sup> (5.75 yd <sup>3</sup> )										5.06 m <sup>3</sup> (6.62 yd <sup>3</sup> )				4.40 m <sup>3</sup> (5.75 yd <sup>3</sup> )					
		Coal	8.20 m <sup>3</sup> (10.73 yd <sup>3</sup> )			9.43 m <sup>3</sup> (12.33 yd <sup>3</sup> )				8.20 m <sup>3</sup> (10.73 yd <sup>3</sup> )												
Material Density		lb/yd <sup>3</sup>	1180	1348	1517	1685	1854	2022	2191	2359	2528	2696	2865	3033	3202	3370	3539	3707	3876	4044	4213	
Bucket Fill Factors		115% 110% 105% 100% 95%																				

Material Density		kg/m <sup>3</sup>	700	800	900	1000	1100	1200	1300	1400	1500	1600	1700	1800	1900	2000	2100	2200	2300	2400	2500	
High Lift Linkage	Pin On	General Purpose	5.40 m <sup>3</sup> (7.06 yd <sup>3</sup> )									6.21 m <sup>3</sup> (8.12 yd <sup>3</sup> )			5.40 m <sup>3</sup> (7.06 yd <sup>3</sup> )							
		Rock	4.40 m <sup>3</sup> (5.75 yd <sup>3</sup> )										5.06 m <sup>3</sup> (6.62 yd <sup>3</sup> )				4.40 m <sup>3</sup> (5.75 yd <sup>3</sup> )					
		Coal	8.20 m <sup>3</sup> (10.73 yd <sup>3</sup> )			9.43 m <sup>3</sup> (12.33 yd <sup>3</sup> )				8.20 m <sup>3</sup> (10.73 yd <sup>3</sup> )												
Material Density		lb/yd <sup>3</sup>	1180	1348	1517	1685	1854	2022	2191	2359	2528	2696	2865	3033	3202	3370	3539	3707	3876	4044	4213	
Bucket Fill Factors		115% 110% 105% 100% 95%																				

Material Density		kg/m <sup>3</sup>	700	800	900	1000	1100	1200	1300	1400	1500	1600	1700	1800	1900	2000	2100	2200	2300	2400	2500	
Aggregate Package Linkage	Pin On	General Purpose	5.70 m <sup>3</sup> (7.46 yd <sup>3</sup> )									6.56 m <sup>3</sup> (8.58 yd <sup>3</sup> )			5.70 m <sup>3</sup> (7.46 yd <sup>3</sup> )							
		Material Handling	6.00 m <sup>3</sup> (7.85 yd <sup>3</sup> )										6.90 m <sup>3</sup> (9.02 yd <sup>3</sup> )			6.00 m <sup>3</sup> (7.85 yd <sup>3</sup> )						
		Material Handling	5.70 m <sup>3</sup> (7.46 yd <sup>3</sup> )											6.56 m <sup>3</sup> (8.58 yd <sup>3</sup> )			5.70 m <sup>3</sup> (7.46 yd <sup>3</sup> )					
Material Density		lb/yd <sup>3</sup>	1180	1348	1517	1685	1854	2022	2191	2359	2528	2696	2865	3033	3202	3370	3539	3707	3876	4044	4213	
Bucket Fill Factors		115% 110% 105% 100% 95%																				

**NOTE:** All buckets are showing Bolt-On Edges. Material Handling buckets are flat floor buckets. Contact your local Cat dealer for product availability.



950 GC

Material Density		kg/m <sup>3</sup>	700	800	900	1000	1100	1200	1300	1400	1500	1600	1700	1800	1900	2000	2100	2200	2300	2400	2500				
Standard Linkage	General Purpose	Pin On	2.70 m <sup>3</sup>											3.11 m <sup>3</sup>			2.70 m <sup>3</sup>								
			3.10 m <sup>3</sup>												3.57 m <sup>3</sup>			3.10 m <sup>3</sup>							
			3.30 m <sup>3</sup>												3.80 m <sup>3</sup>			3.30 m <sup>3</sup>							
			3.40 m <sup>3</sup>												3.91 m <sup>3</sup>			3.40 m <sup>3</sup>							
			3.60 m <sup>3</sup>												4.14 m <sup>3</sup>			3.60 m <sup>3</sup>							
	Hook On	3.10 m <sup>3</sup>											3.57 m <sup>3</sup>			3.10 m <sup>3</sup>									
Material Handling	Pin On	4.40 m <sup>3</sup>				5.06 m <sup>3</sup>			4.40 m <sup>3</sup>																
Bucket Fill Factors		115% 110% 105% 100% 95% 																							

**NOTE:** All buckets are showing Bolt-On Edges.  
Machine and bucket availability varies by region. Contact your local Cat dealer for product availability.

950H

Material Density		kg/m <sup>3</sup>	700	800	900	1000	1100	1200	1300	1400	1500	1600	1700	1800	1900	2000	2100	2200	2300	2400	2500			
Standard Linkage	Pin On	General Purpose	2.70 m <sup>3</sup> (3.53 yd <sup>3</sup> )																					
			3.10 m <sup>3</sup> (4.05 yd <sup>3</sup> )																					
			3.40 m <sup>3</sup> (4.45 yd <sup>3</sup> )																					
	Material Handling	3.20 m <sup>3</sup> (4.19 yd <sup>3</sup> )																						
		3.40 m <sup>3</sup> (4.45 yd <sup>3</sup> )																						
		3.60 m <sup>3</sup> (4.71 yd <sup>3</sup> )																						
High Lift Linkage	Pin On	General Purpose	2.70 m <sup>3</sup> (3.53 yd <sup>3</sup> )																					
			3.10 m <sup>3</sup> (4.05 yd <sup>3</sup> )																					
			3.40 m <sup>3</sup> (4.45 yd <sup>3</sup> )																					
	Material Handling	3.20 m <sup>3</sup> (4.19 yd <sup>3</sup> )																						
		3.40 m <sup>3</sup> (4.45 yd <sup>3</sup> )																						
		3.60 m <sup>3</sup> (4.71 yd <sup>3</sup> )																						
Material Density		lb/yd <sup>3</sup>	1180	1348	1517	1685	1854	2022	2191	2359	2528	2696	2865	3033	3202	3370	3539	3707	3876	4044	4213			
Bucket Fill Factors		115% 110% 105% 100% 95% 																						

NOTE: All buckets are showing Bolt-On Edges.

962H

Material Density		kg/m <sup>3</sup>	700	800	900	1000	1100	1200	1300	1400	1500	1600	1700	1800	1900	2000	2100	2200	2300	2400	2500			
Standard Linkage	Pin On	General Purpose	3.10 m <sup>3</sup> (4.05 yd <sup>3</sup> )																					
			3.40 m <sup>3</sup> (4.45 yd <sup>3</sup> )																					
			3.60 m <sup>3</sup> (4.71 yd <sup>3</sup> )																					
	Pin On	Material Handling	3.40 m <sup>3</sup> (4.45 yd <sup>3</sup> )																					
			3.60 m <sup>3</sup> (4.71 yd <sup>3</sup> )																					
			3.80 m <sup>3</sup> (4.97 yd <sup>3</sup> )																					
High Lift Linkage	Pin On	General Purpose	3.10 m <sup>3</sup> (4.05 yd <sup>3</sup> )																					
			3.40 m <sup>3</sup> (4.45 yd <sup>3</sup> )																					
			3.60 m <sup>3</sup> (4.71 yd <sup>3</sup> )																					
	Pin On	Material Handling	3.40 m <sup>3</sup> (4.45 yd <sup>3</sup> )																					
			3.60 m <sup>3</sup> (4.71 yd <sup>3</sup> )																					
			3.80 m <sup>3</sup> (4.97 yd <sup>3</sup> )																					
Material Density		lb/yd <sup>3</sup>	1180	1348	1517	1685	1854	2022	2191	2359	2528	2696	2865	3033	3202	3370	3539	3707	3876	4044	4213			
Bucket Fill Factors		115% 110% 105% 100% 95% 																						

NOTE: All buckets are showing Bolt-On Edges.

966H

Material Density		kg/m <sup>3</sup>	700	800	900	1000	1100	1200	1300	1400	1500	1600	1700	1800	1900	2000	2100	2200	2300	2400			
Standard Linkage	Pin On	General Purpose	3.80 m <sup>3</sup> (4.97 yd <sup>3</sup> )																				
			4.00 m <sup>3</sup> (5.23 yd <sup>3</sup> )																				
			4.20 m <sup>3</sup> (5.49 yd <sup>3</sup> )																				
			4.60 m <sup>3</sup> (6.02 yd <sup>3</sup> )																				
	Rock	3.40 m <sup>3</sup> (4.45 yd <sup>3</sup> )																					
		4.00 m <sup>3</sup> (5.23 yd <sup>3</sup> )																					
	Material Handling/Standard	4.00 m <sup>3</sup> (5.23 yd <sup>3</sup> )																					
		4.60 m <sup>3</sup> (6.02 yd <sup>3</sup> )																					
Material Density		lb/yd <sup>3</sup>	1180	1348	1517	1685	1854	2022	2191	2359	2528	2696	2865	3033	3202	3370	3539	3707	3876	4044			
Bucket Fill Factors		115% 110% 105% 100% 95%																					

NOTE: All buckets are showing Bolt-On Edges.

**972H**

Material Density		kg/m <sup>3</sup>	700	800	900	1000	1100	1200	1300	1400	1500	1600	1700	1800	1900	2000	2100	2200	2300	2400		
Standard Linkage	Pin On	General Purpose	4.20 m <sup>3</sup> (5.49 yd <sup>3</sup> )											4.83 m <sup>3</sup> (6.32 yd <sup>3</sup> )						4.20 m <sup>3</sup> (5.49 yd <sup>3</sup> )		
			4.60 m <sup>3</sup> (6.02 yd <sup>3</sup> )									5.29 m <sup>3</sup> (6.92 yd <sup>3</sup> )										4.60 m <sup>3</sup> (6.02 yd <sup>3</sup> )
		Material Handling	4.60 m <sup>3</sup> (6.02 yd <sup>3</sup> )									5.29 m <sup>3</sup> (6.92 yd <sup>3</sup> )										4.60 m <sup>3</sup> (6.02 yd <sup>3</sup> )
		Rock	4.00 m <sup>3</sup> (5.23 yd <sup>3</sup> )									4.60 m <sup>3</sup> (6.02 yd <sup>3</sup> )										4.00 m <sup>3</sup> (5.23 yd <sup>3</sup> )
	Material Handling/Standard	4.60 m <sup>3</sup> (6.02 yd <sup>3</sup> )										5.29 m <sup>3</sup> (6.92 yd <sup>3</sup> )										4.60 m <sup>3</sup> (6.02 yd <sup>3</sup> )
		5.00 m <sup>3</sup> (6.54 yd <sup>3</sup> )									5.75 m <sup>3</sup> (7.52 yd <sup>3</sup> )											5.00 m <sup>3</sup> (6.54 yd <sup>3</sup> )
	Material Density		lb/yd <sup>3</sup>	1180	1348	1517	1685	1854	2022	2191	2359	2528	2696	2865	3033	3202	3370	3539	3707	3876	4044	
	Bucket Fill Factors		115% 110% 105% 100% 95% 																			

**NOTE:** All buckets are showing Bolt-On Edges.



**986H — Standard Lift**

<b>Material Density</b>				<b>Bucket Volume</b>	
<b>kg/m<sup>3</sup></b>	<b>tonnes/m<sup>3</sup></b>	<b>lb/yd<sup>3</sup></b>	<b>tons/yd<sup>3</sup></b>	<b>m<sup>3</sup></b>	<b>yd<sup>3</sup></b>
1632-1795	1.63-1.80	<b>2750-3025</b>	<b>1.38-1.51</b>	6.1	<b>8</b>
1740-1914	1.74-1.91	<b>2933-3227</b>	<b>1.46-1.61</b>	5.7	<b>7.5</b>
1865-2051	1.86-2.05	<b>3143-3457</b>	<b>1.57-1.73</b>	5.4	<b>7</b>

\*Density range covers 100% rated payload to 110% rated payload in accordance with Large Wheel Loader payload policy.

**988K**

<b>Material Density</b>				<b>Bucket Volume</b>	
<b>kg/m<sup>3</sup></b>	<b>tonnes/m<sup>3</sup></b>	<b>lb/yd<sup>3</sup></b>	<b>tons/yd<sup>3</sup></b>	<b>m<sup>3</sup></b>	<b>yd<sup>3</sup></b>
1468-1614	1.47-1.61	<b>2500-2750</b>	<b>1.25-1.38</b>	7.7	<b>10</b>
1638-1801	1.64-1.80	<b>2778-3056</b>	<b>1.39-1.53</b>	6.9	<b>9</b>
1766-1942	1.77-1.94	<b>3001-3300</b>	<b>1.50-1.65</b>	6.4	<b>8.33</b>

**990K**

<b>Material Density</b>				<b>Bucket Volume</b>	
<b>kg/m<sup>3</sup></b>	<b>tonnes/m<sup>3</sup></b>	<b>lb/yd<sup>3</sup></b>	<b>tons/yd<sup>3</sup></b>	<b>m<sup>3</sup></b>	<b>yd<sup>3</sup></b>
1590-1749	1.59-1.75	<b>2692-2962</b>	<b>1.35-1.48</b>	10	<b>13</b>
1728-1901	1.73-1.90	<b>2917-3208</b>	<b>1.46-1.60</b>	9.2	<b>12</b>
1849-2034	1.85-2.03	<b>3111-3422</b>	<b>1.56-1.71</b>	8.6	<b>11.25</b>

**992K — Standard**

*Up to specified density for 100% fill factor*

Bucket Volume		Material Density	
m <sup>3</sup>	yd <sup>3</sup>	kg/m <sup>3</sup>	lb/yd <sup>3</sup>
12.2	16	1780	3000
11.5	15	1890	3200
10.7	14	2030	3430

**992K — High Lift**

*Up to specified density for 100% fill factor*

Bucket Volume		Material Density	
m <sup>3</sup>	yd <sup>3</sup>	kg/m <sup>3</sup>	lb/yd <sup>3</sup>
12.2	16	1560	2630
11.5	15	1560	2630
10.7	14	1560	2630

**993K — Standard**

*Up to specified density for 100% fill factor*

Bucket Volume		Material Density	
m <sup>3</sup>	yd <sup>3</sup>	kg/m <sup>3</sup>	lb/yd <sup>3</sup>
15.3	20	1780	3000
14.5	19	1870	3160
13.8	18	1970	3330

**993K — High Lift**

*Up to specified density for 100% fill factor*

Bucket Volume		Material Density	
m <sup>3</sup>	yd <sup>3</sup>	kg/m <sup>3</sup>	lb/yd <sup>3</sup>
14.5	19	1720	2890
13.8	18	1810	3060
13.0	17	1920	3240



**994K Standard Lift**

Bucket Type	Bucket Volume		Material Density	
	m <sup>3</sup>	yd <sup>3</sup>	kg/m <sup>3</sup>	lb/yd <sup>3</sup>
Rock	19.1	25	2138	3600
	21.4	28	1909	3215
	22.9	30	1781	3000
	24.5	32	1669	2810
HD Rock	19.1	25	2090	3520
	21.4	28	1802	3035
Coal	32.1	42	1271	2140
	39.8	52	1027	1730
Iron Ore	17.2	22.5	2286	3850

**994K High Lift**

Bucket Type	Bucket Volume		Material Density	
	m <sup>3</sup>	yd <sup>3</sup>	kg/m <sup>3</sup>	lb/yd <sup>3</sup>
Rock	19.1	25	1995	3360
	21.4	28	1781	3000
	22.9	30	1663	2800
	24.5	32	1559	2625
HD Rock	19.1	25	1900	3200
	21.4	28	1675	2820
Coal	32.1	42	1188	2000
	39.8	52	959	1615
Iron Ore	17.2	22.5	2126	3580

### 926M TRAVEL TIME — LOADED

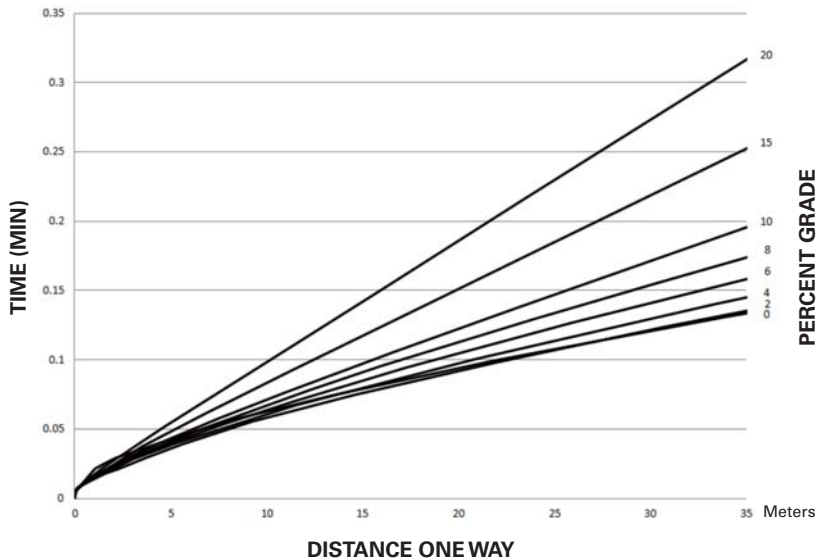
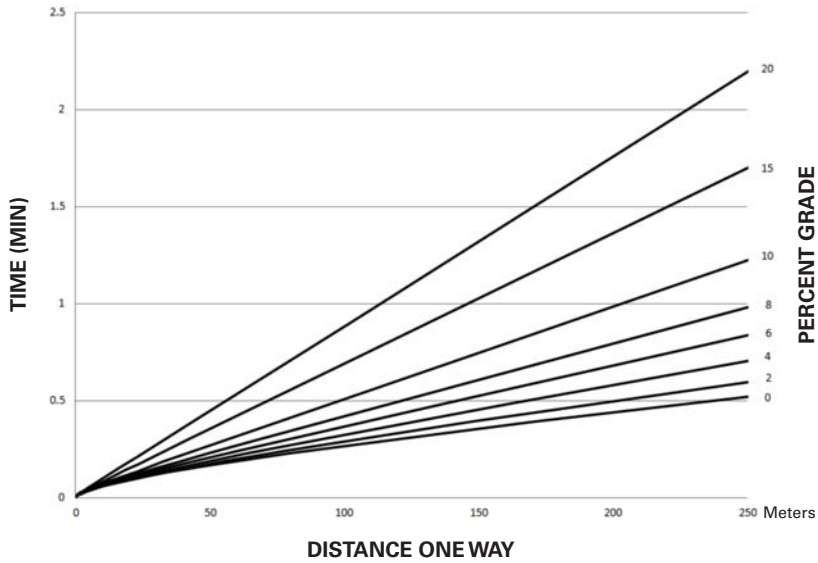

**NOTE:** 926M Configuration: 2.1 m<sup>3</sup> (2.75 yd<sup>3</sup>) bucket; 1780 kg/m<sup>3</sup> (3000 lb/yd<sup>3</sup>) material density; 105% fill factor; 13 050 kg (28,770 lb) machine mass  
Meets Tier 4 Final/Stage IV/Japan 2014 (Tier 4 Final) emission standards.  
Travel time assumes maximum governor pedal depression and automatic shifting in Range 4.  
In load and carry applications it is important to consult the tire manufacturer on Ton-MPH ratings and pressure recommendations.

### 926M TRAVEL TIME — EMPTY

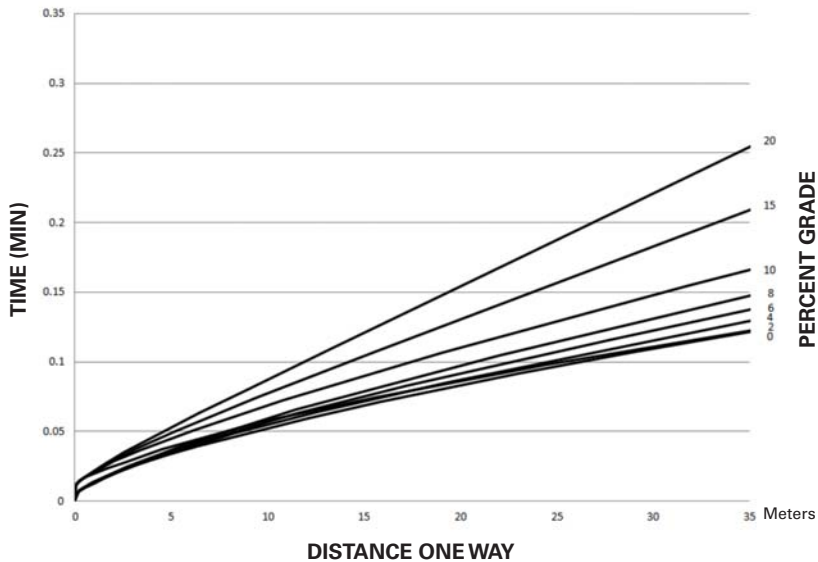
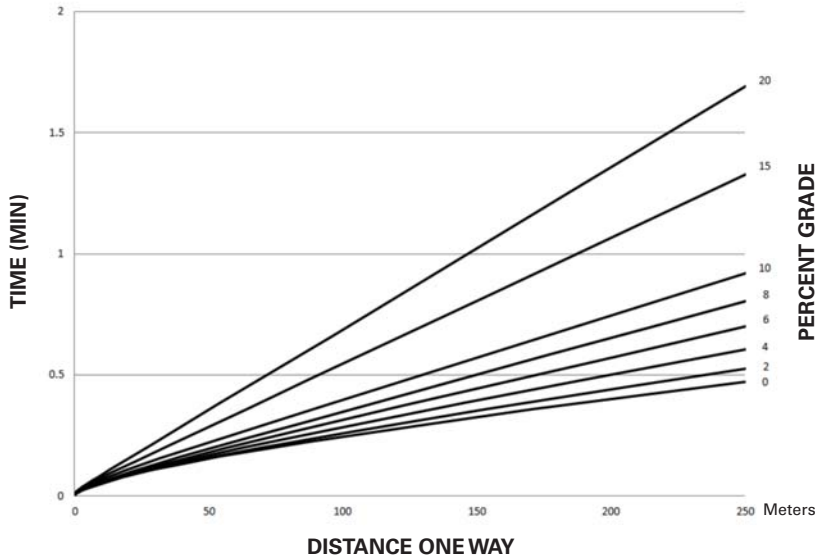

**NOTE:** 926M Configuration: 2.1 m<sup>3</sup> (2.75 yd<sup>3</sup>) bucket; 1780 kg/m<sup>3</sup> (3000 lb/yd<sup>3</sup>) material density; 105% fill factor; 13 050 kg (28,770 lb) machine mass  
Meets Tier 4 Final/Stage IV/Japan 2014 (Tier 4 Final) emission standards.  
Travel time assumes maximum governor pedal depression and automatic shifting in Range 4.  
In load and carry applications it is important to consult the tire manufacturer on Ton-MPH ratings and pressure recommendations.

### 930M TRAVEL TIME — LOADED

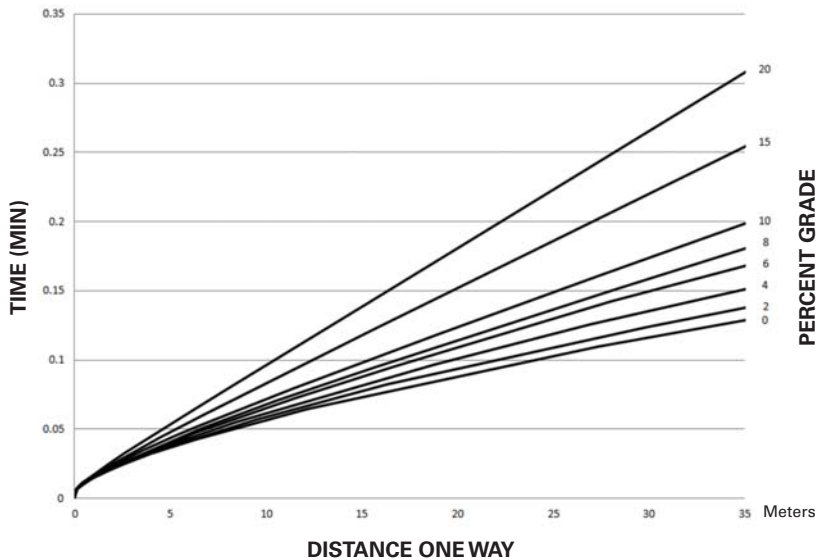
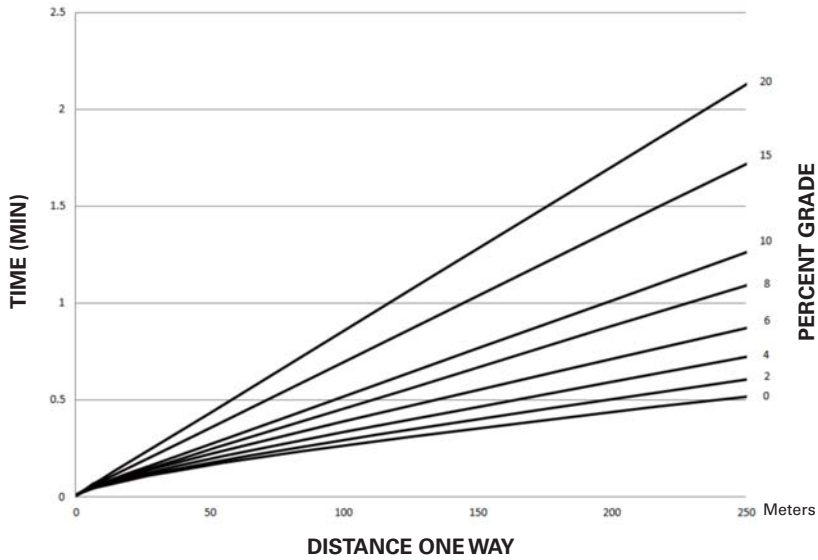

**NOTE:** 930M Configuration: 2.3 m<sup>3</sup> (3.0 yd<sup>3</sup>) bucket; 1780 kg/m<sup>3</sup> (3000 lb/yd<sup>3</sup>) material density; 105% fill factor; 14 007 kg (30,880 lb) machine mass  
Meets Tier 4 Final/Stage IV/Japan 2014 (Tier 4 Final) emission standards.  
Travel time assumes maximum governor pedal depression and automatic shifting in Range 4.  
In load and carry applications it is important to consult the tire manufacturer on Ton-MPH ratings and pressure recommendations.

### 930M TRAVEL TIME — EMPTY

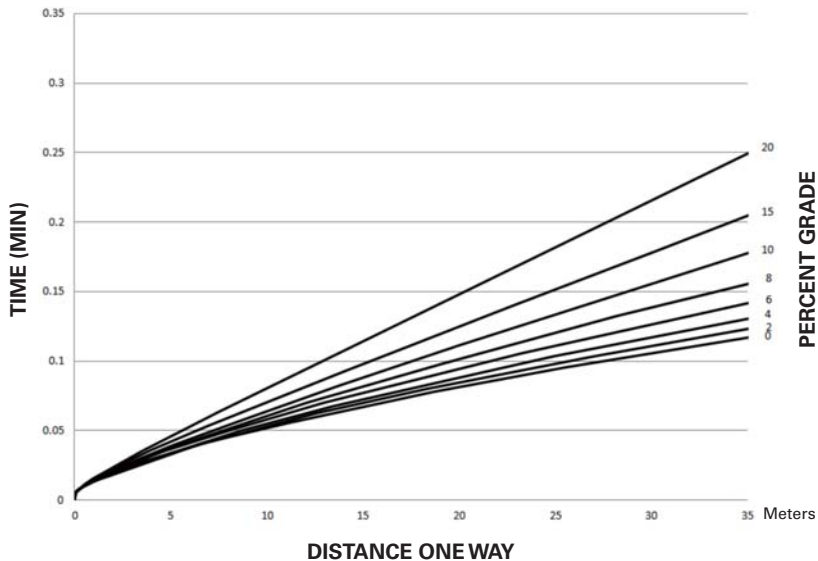
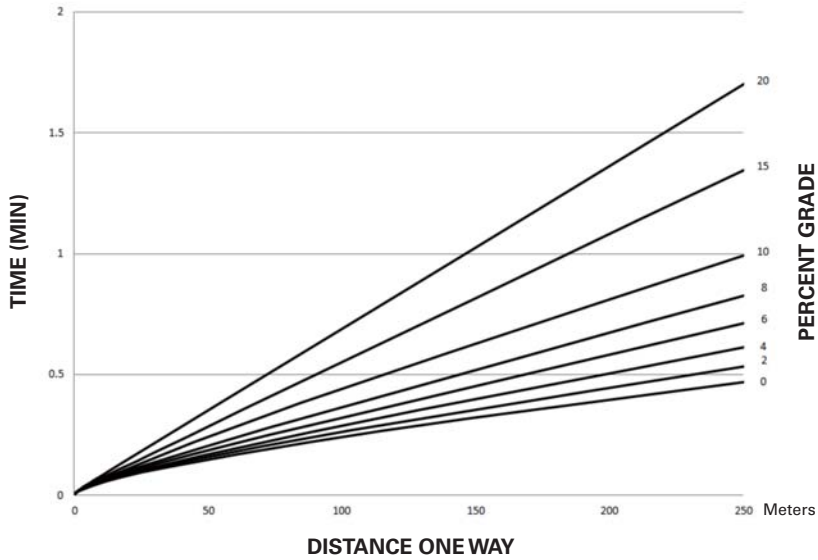

**NOTE:** 930M Configuration: 2.3 m<sup>3</sup> (3.5 yd<sup>3</sup>) bucket; 1780 kg/m<sup>3</sup> (3000 lb/yd<sup>3</sup>) material density; 105% fill factor; 14 007 kg (34,017 lb) machine mass  
Meets Tier 4 Final/Stage IV/Japan 2014 (Tier 4 Final) emission standards.  
Travel time assumes maximum governor pedal depression and automatic shifting in Range 4.  
In load and carry applications it is important to consult the tire manufacturer on Ton-MPH ratings and pressure recommendations.

### 938M TRAVEL TIME — LOADED

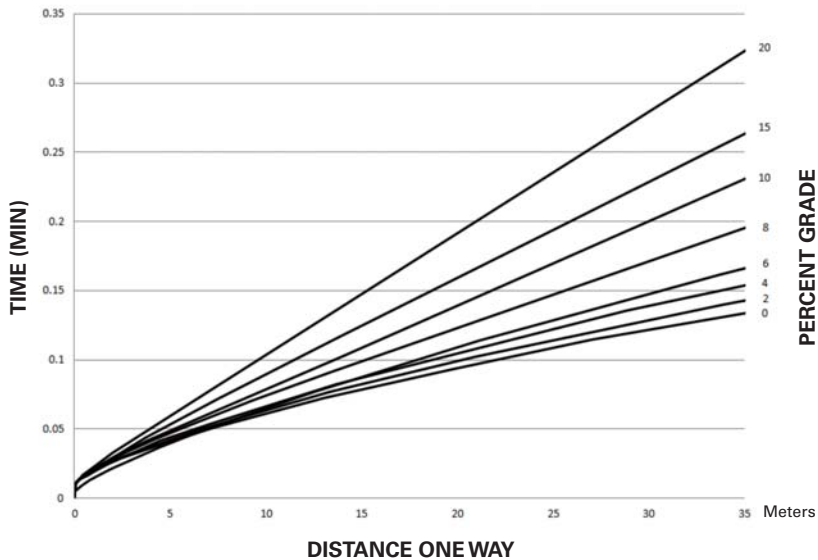
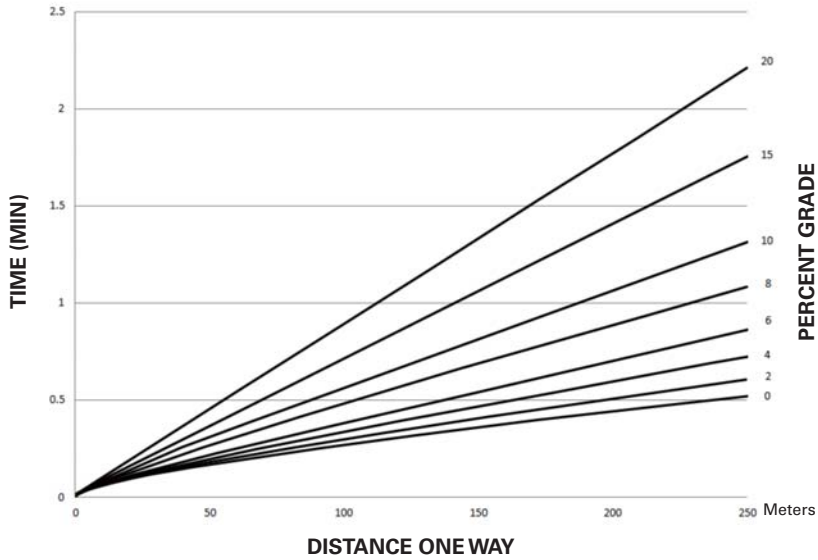

**NOTE:** 938M Configuration: 2.7 m<sup>3</sup> (3.5 yd<sup>3</sup>) bucket; 1780 kg/m<sup>3</sup> (3000 lb/yd<sup>3</sup>) material density; 105% fill factor; 16 427 kg (36,215 lb) machine mass  
Meets Tier 4 Final/Stage IV/Japan 2014 (Tier 4 Final) emission standards.  
Travel time assumes maximum governor pedal depression and automatic shifting in Range 4.  
In load and carry applications it is important to consult the tire manufacturer on Ton-MPH ratings and pressure recommendations.

### 938M TRAVEL TIME — EMPTY

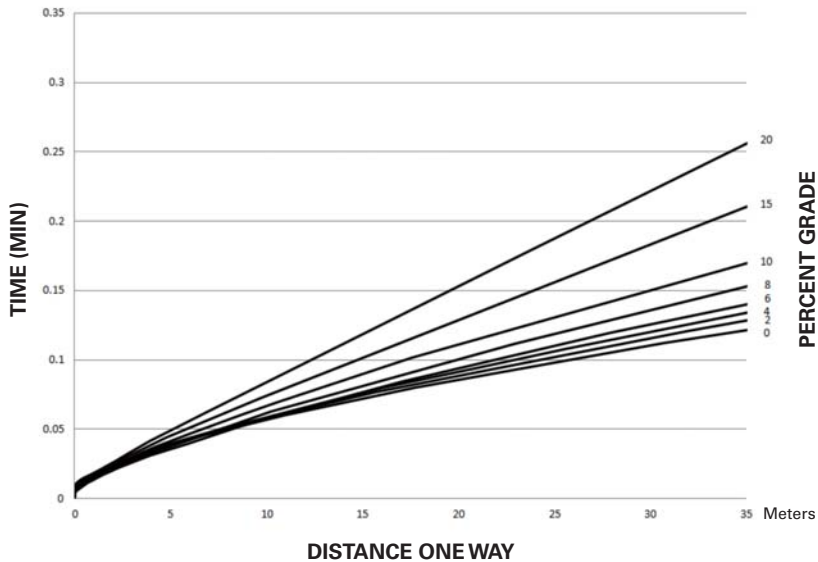
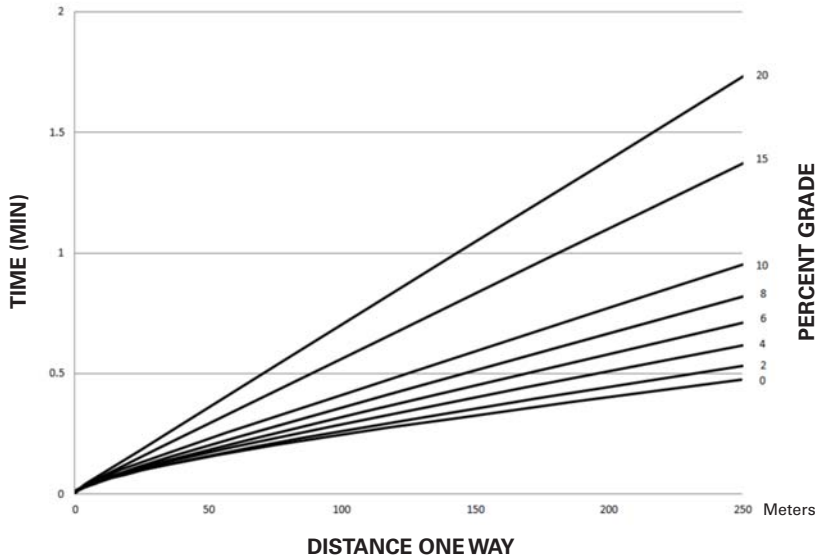

**NOTE:** 938M Configuration: 2.7 m<sup>3</sup> (3.5 yd<sup>3</sup>) bucket; 1780 kg/m<sup>3</sup> (3000 lb/yd<sup>3</sup>) material density; 105% fill factor; 16 427 kg (36,215 lb) machine mass  
Meets Tier 4 Final/Stage IV/Japan 2014 (Tier 4 Final) emission standards.  
Travel time assumes maximum governor pedal depression and automatic shifting in Range 4.  
In load and carry applications it is important to consult the tire manufacturer on Ton-MPH ratings and pressure recommendations.

### 924K TRAVEL TIME — LOADED

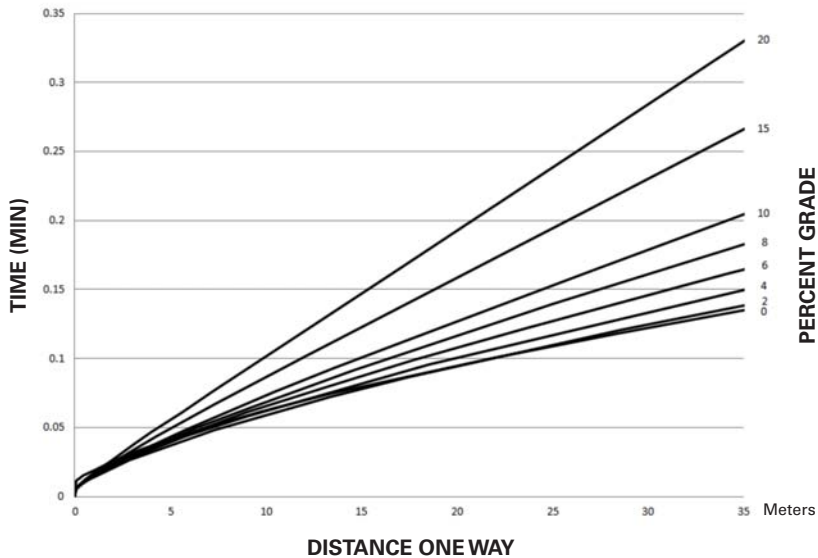
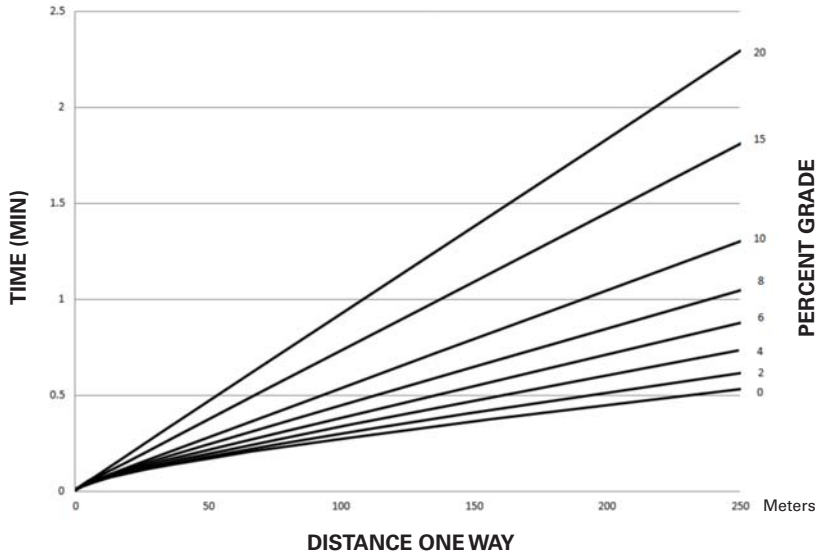

**NOTE:** 924K Configuration: 2.1 m<sup>3</sup> (2.75 yd<sup>3</sup>) bucket; 1780 kg/m<sup>3</sup> (3000 lb/yd<sup>3</sup>) material density; 105% fill factor; 11 966 kg (26,380 lb) machine mass  
 Travel time assumes maximum governor pedal depression and automatic shifting in Range 4.  
 In load and carry applications it is important to consult the tire manufacturer on Ton-MPH ratings and pressure recommendations.



### 924K TRAVEL TIME — EMPTY

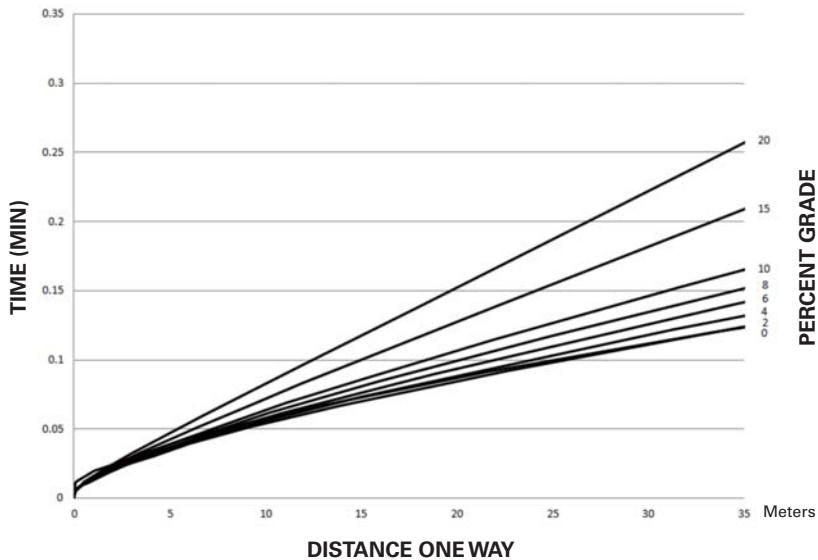
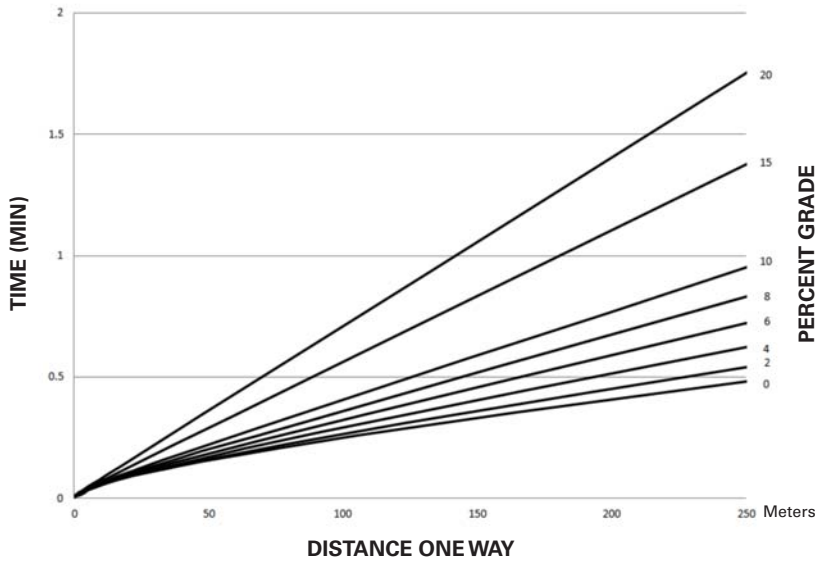

**NOTE:** 924K Configuration: 2.1 m<sup>3</sup> (2.75 yd<sup>3</sup>) bucket; 1780 kg/m<sup>3</sup> (3000 lb/yd<sup>3</sup>) material density; 105% fill factor; 11 966 kg (26,380 lb) machine mass  
Travel time assumes maximum governor pedal depression and automatic shifting in Range 4.  
In load and carry applications it is important to consult the tire manufacturer on Ton-MPH ratings and pressure recommendations.

### 930K TRAVEL TIME — LOADED

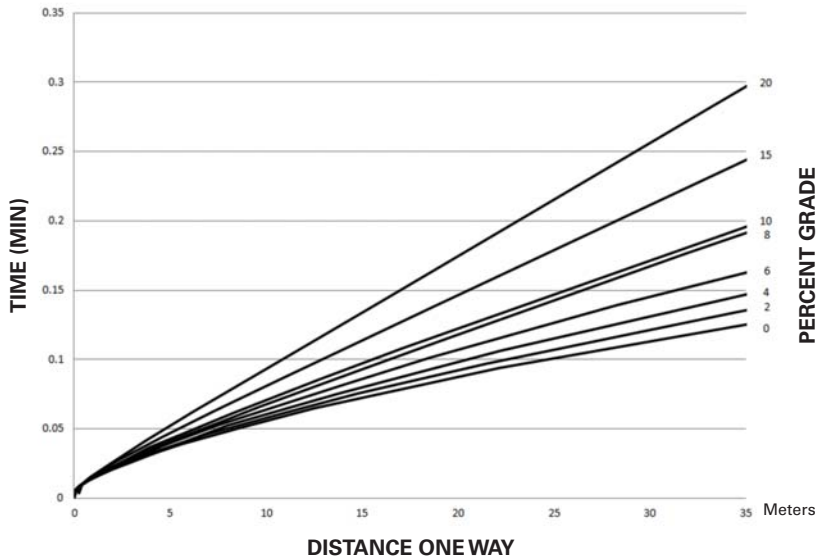
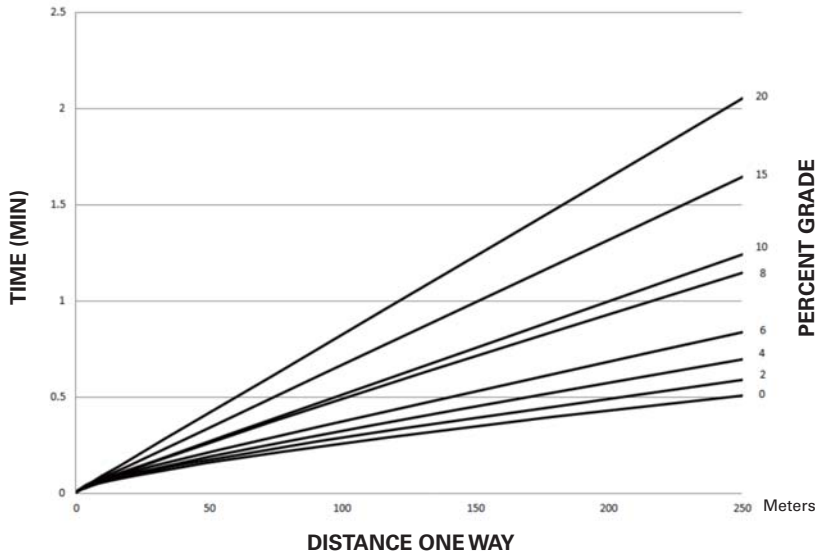

**NOTE:** 930K Configuration: 2.3 m<sup>3</sup> (3.0 yd<sup>3</sup>) bucket; 1780 kg/m<sup>3</sup> (3000 lb/yd<sup>3</sup>) material density; 105% fill factor; 13 135 kg (28,957 lb) machine mass  
Travel time assumes maximum governor pedal depression and automatic shifting in Range 4.  
In load and carry applications it is important to consult the tire manufacturer on Ton-MPH ratings and pressure recommendations.

### 930K TRAVEL TIME — EMPTY

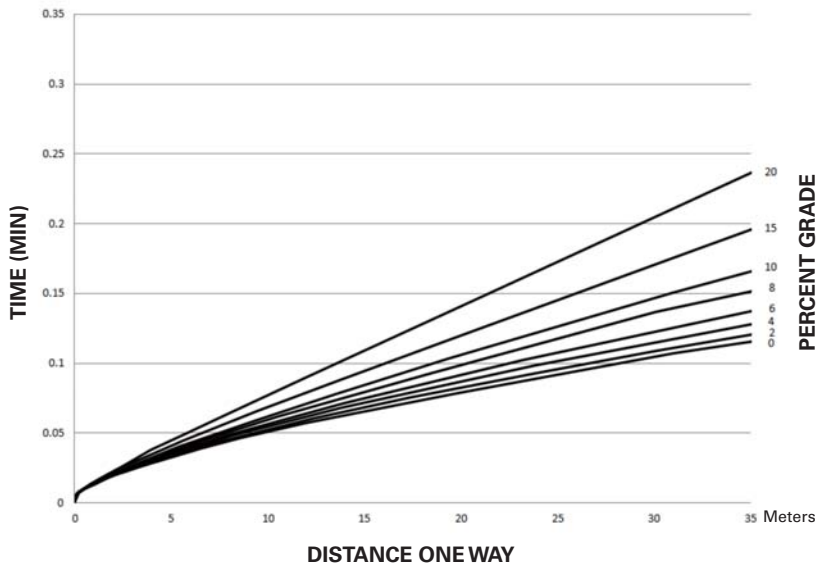
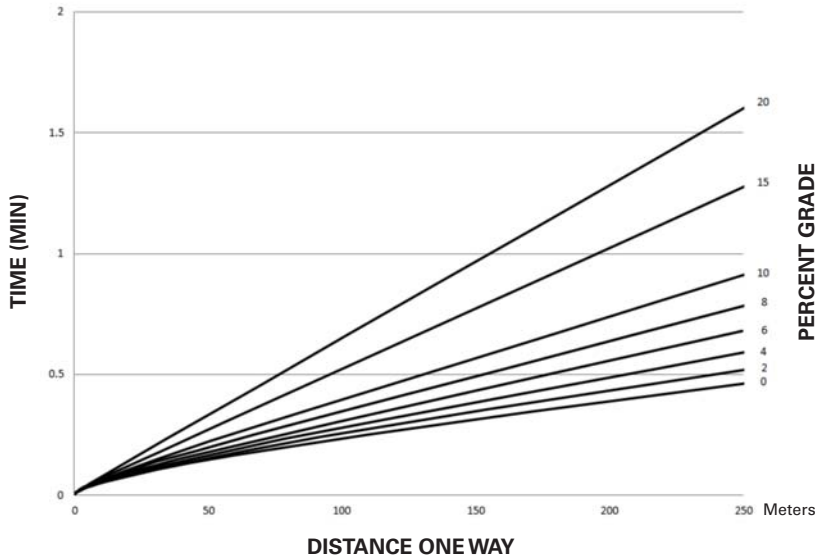

**NOTE:** 930K Configuration: 2.3 m<sup>3</sup> (3.0 yd<sup>3</sup>) bucket; 1780 kg/m<sup>3</sup> (3000 lb/yd<sup>3</sup>) material density; 105% fill factor; 13 135 kg (28,957 lb) machine mass  
Travel time assumes maximum governor pedal depression and automatic shifting in Range 4.  
In load and carry applications it is important to consult the tire manufacturer on Ton-MPH ratings and pressure recommendations.

### 938K TRAVEL TIME — LOADED

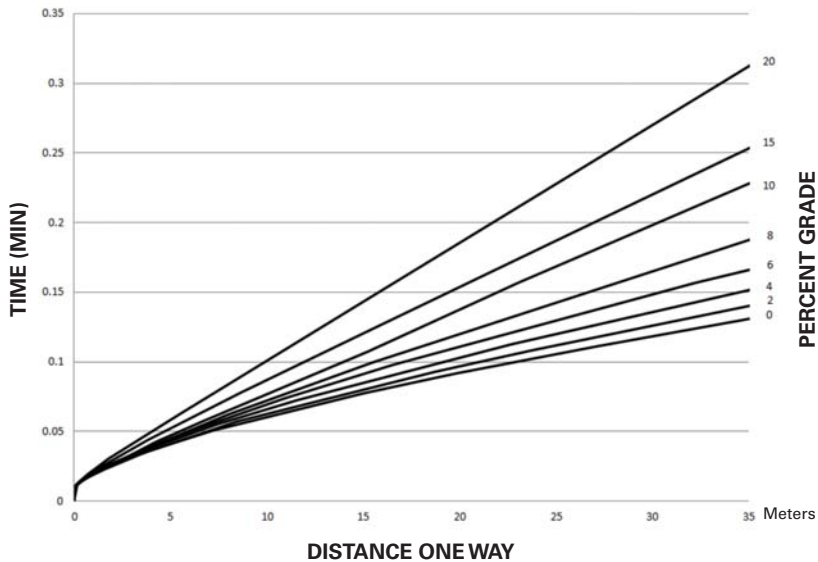
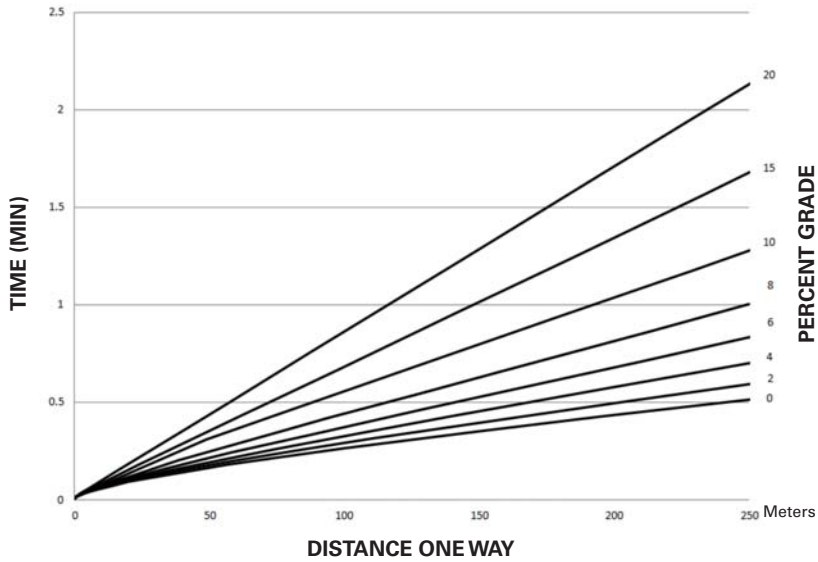

**NOTE:** 938K Configuration: 2.7 m<sup>3</sup> (3.5 yd<sup>3</sup>) bucket; 1780 kg/m<sup>3</sup> (3000 lb/yd<sup>3</sup>) material density; 105% fill factor; 15 430 kg (34,017 lb) machine mass  
 Travel time assumes maximum governor pedal depression and automatic shifting in Range 4.  
 In load and carry applications it is important to consult the tire manufacturer on Ton-MPH ratings and pressure recommendations.

### 938K TRAVEL TIME — EMPTY

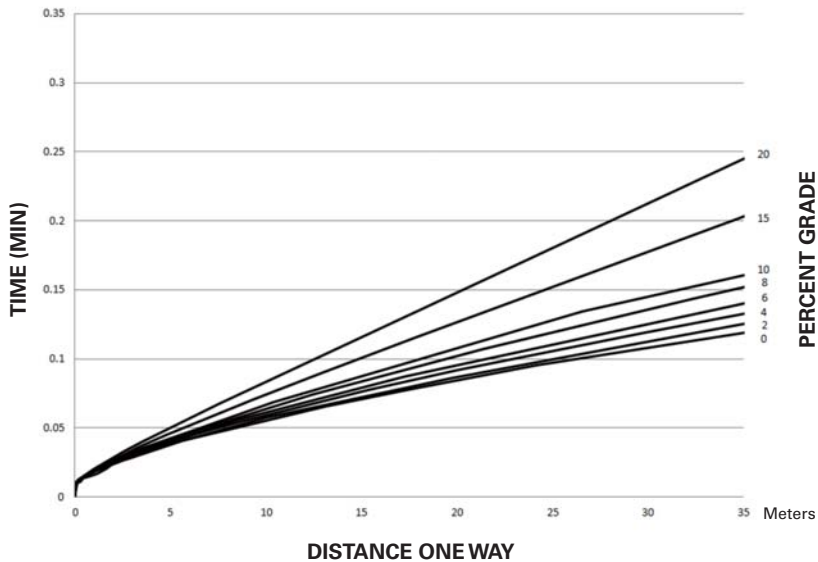
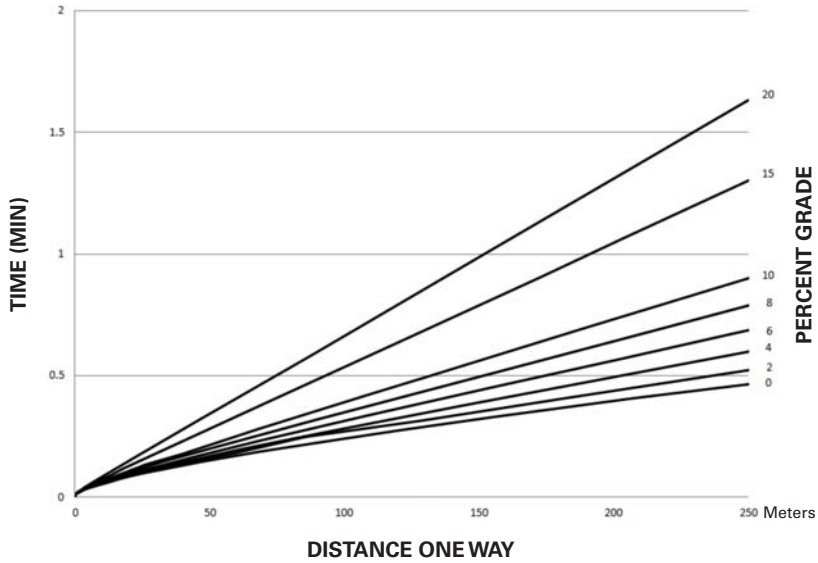

**NOTE:** 938K Configuration: 2.7 m<sup>3</sup> (3.5 yd<sup>3</sup>) bucket; 1780 kg/m<sup>3</sup> (3000 lb/yd<sup>3</sup>) material density; 105% fill factor; 15 430 kg (34,017 lb) machine mass  
Travel time assumes maximum governor pedal depression and automatic shifting in Range 4.  
In load and carry applications it is important to consult the tire manufacturer on Ton-MPH ratings and pressure recommendations.

**950M TRAVEL TIME — LOADED**

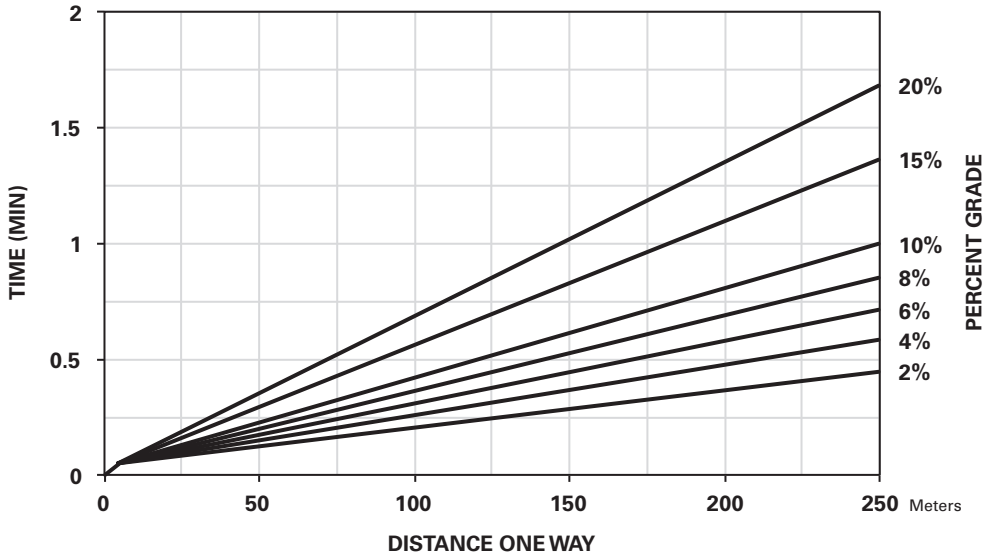

**950M TRAVEL TIME — EMPTY**

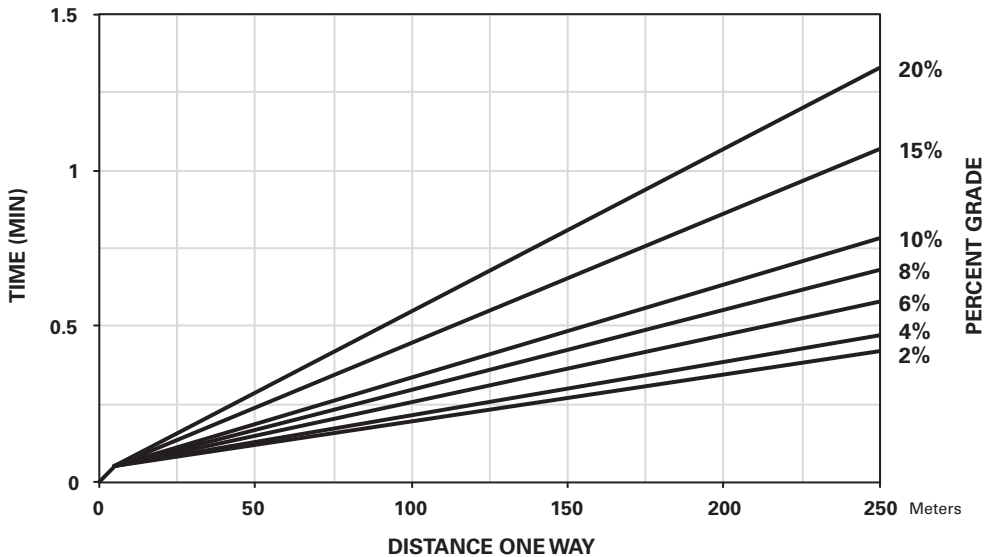

Curves assume use of highest operating speed attainable.

In load-and-carry applications it is important to consult the tire manufacturer on load-speed ratings and pressure recommendations.

Meets Tier 4 Final, Stage IV and Japan 2014 (Tier 4 Final) emission standards.

- 962M
- 23.5R25 Tires

**962M TRAVEL TIME — LOADED**

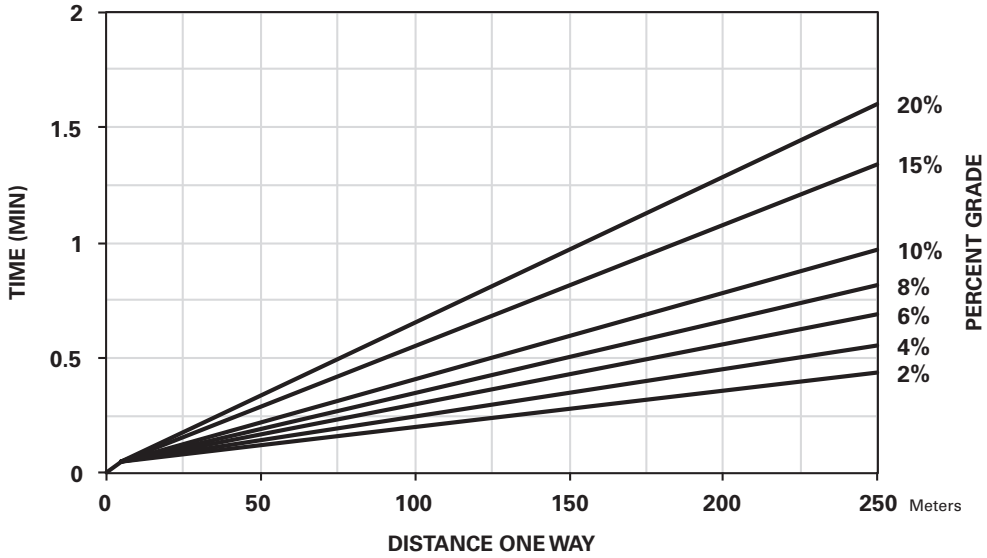

**962M TRAVEL TIME — EMPTY**

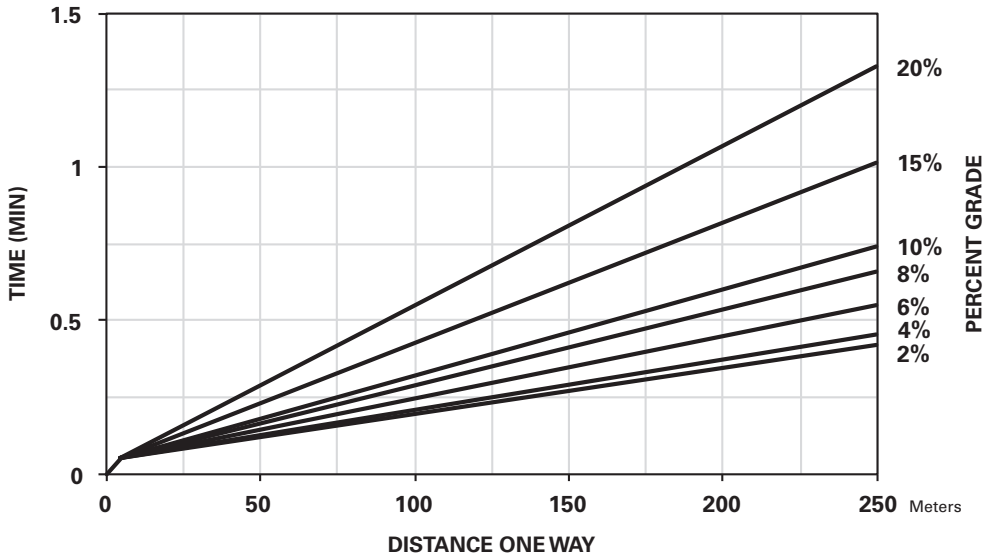

Curves assume use of highest operating speed attainable.

In load-and-carry applications it is important to consult the tire manufacturer on load-speed ratings and pressure recommendations.

Meets Tier 4 Final, Stage IV and Japan 2014 (Tier 4 Final) emission standards.

**966M TRAVEL TIME — LOADED**

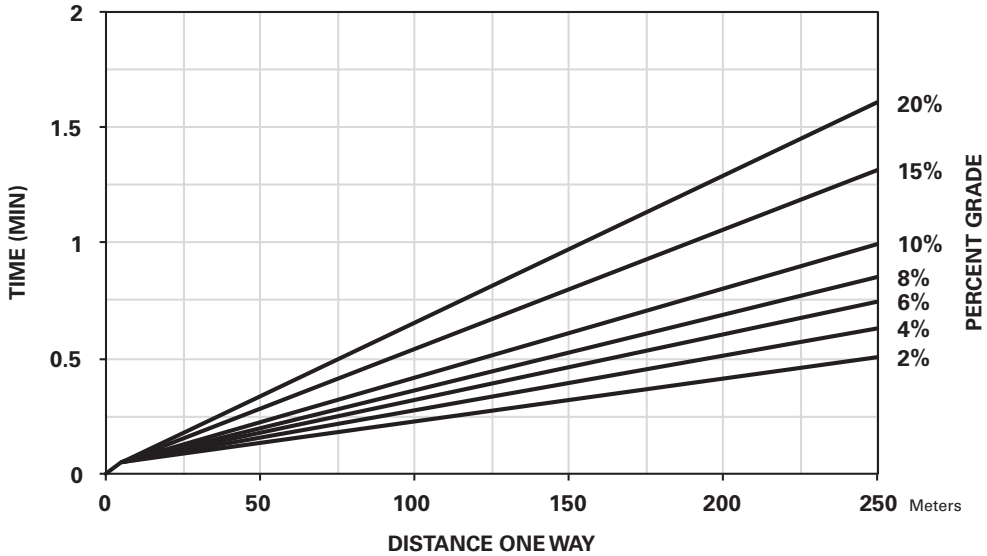

**966M TRAVEL TIME — EMPTY**

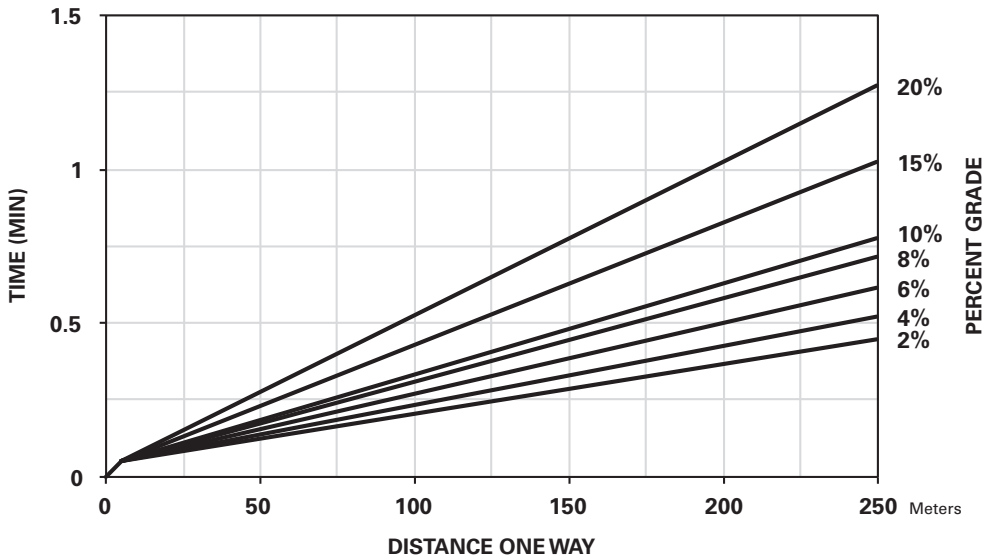

Curves assume use of highest operating speed attainable.

In load-and-carry applications it is important to consult the tire manufacturer on load-speed ratings and pressure recommendations.

Meets Tier 4 Final, Stage IV and Japan 2014 (Tier 4 Final) emission standards.



- 966M XE
- 26.5R25 Tires

**966M XE TRAVEL TIME — LOADED**

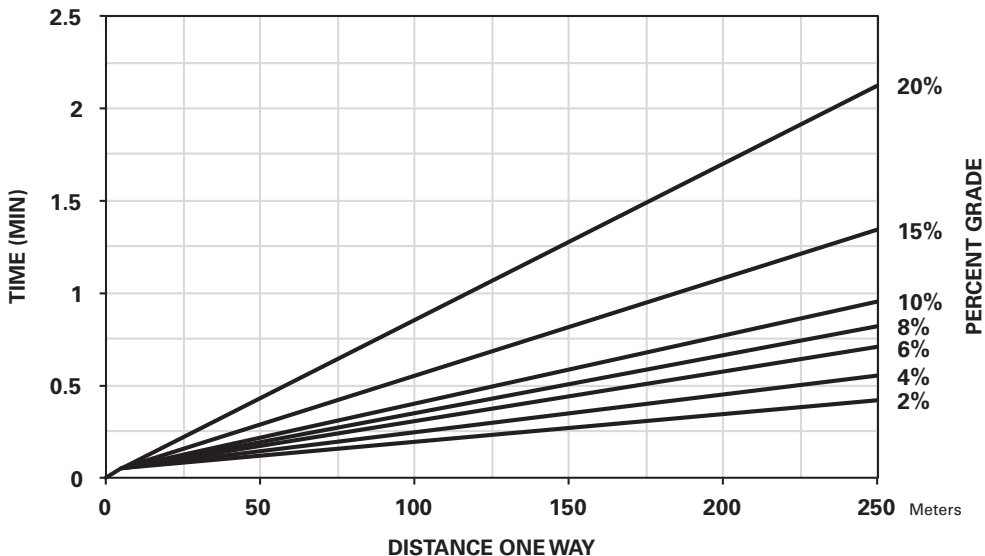

**966M XE TRAVEL TIME — EMPTY**

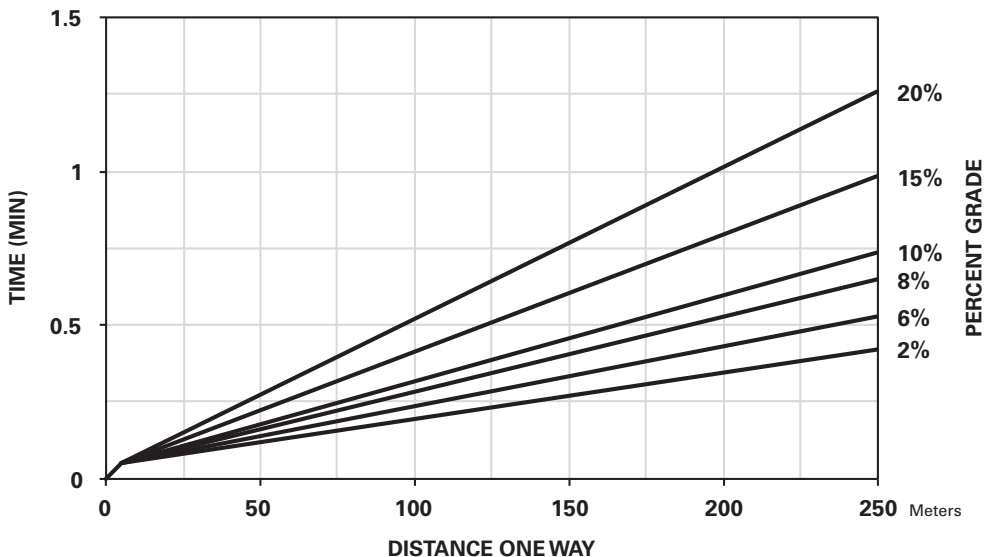

Curves assume use of highest operating speed attainable.

In load-and-carry applications it is important to consult the tire manufacturer on load-speed ratings and pressure recommendations.

Meets Tier 4 Final, Stage IV and Japan 2014 (Tier 4 Final) emission standards.

**972M TRAVEL TIME — LOADED**

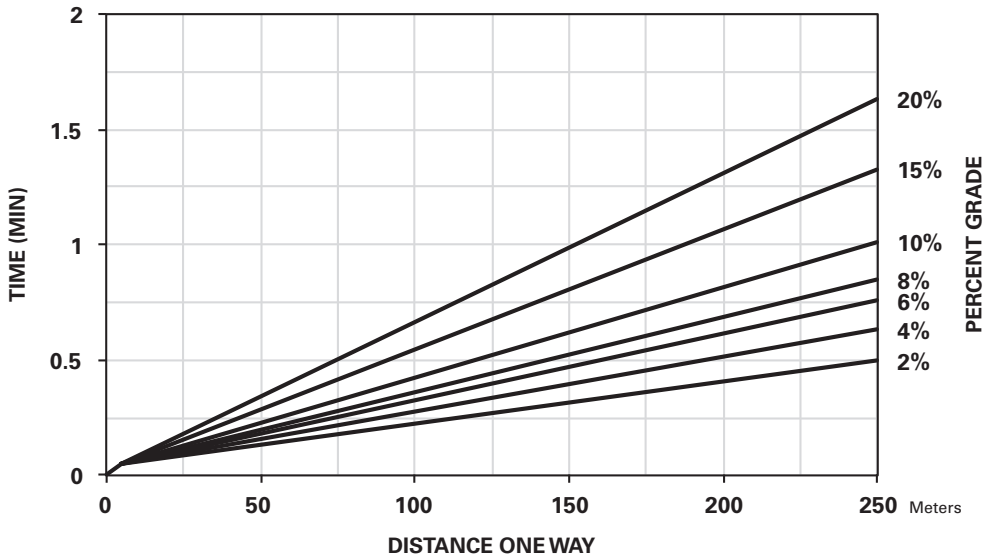

**972M TRAVEL TIME — EMPTY**

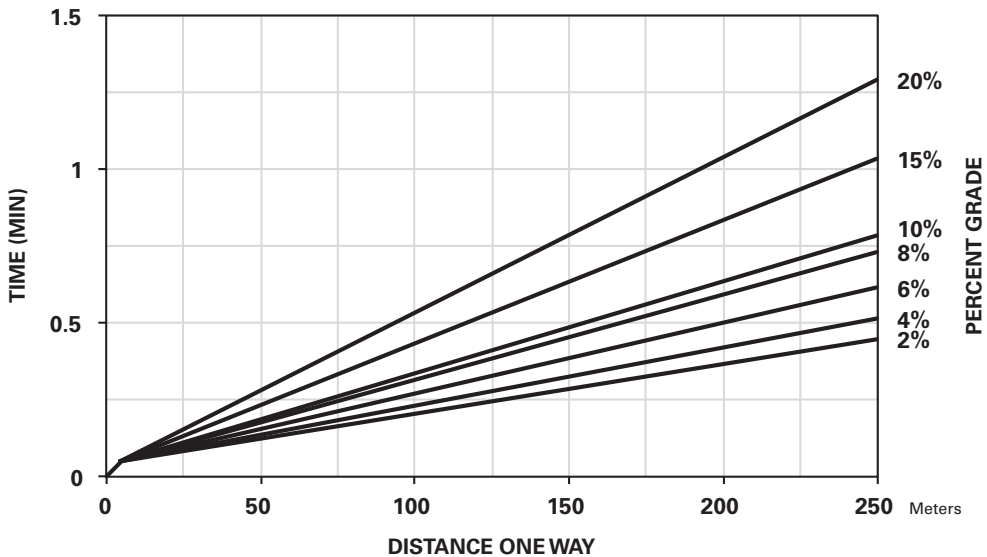

Curves assume use of highest operating speed attainable.

In load-and-carry applications it is important to consult the tire manufacturer on load-speed ratings and pressure recommendations.

Meets Tier 4 Final, Stage IV and Japan 2014 (Tier 4 Final) emission standards.

- 972M XE
- 26.5R25 Tires

**972M XE TRAVEL TIME — LOADED**

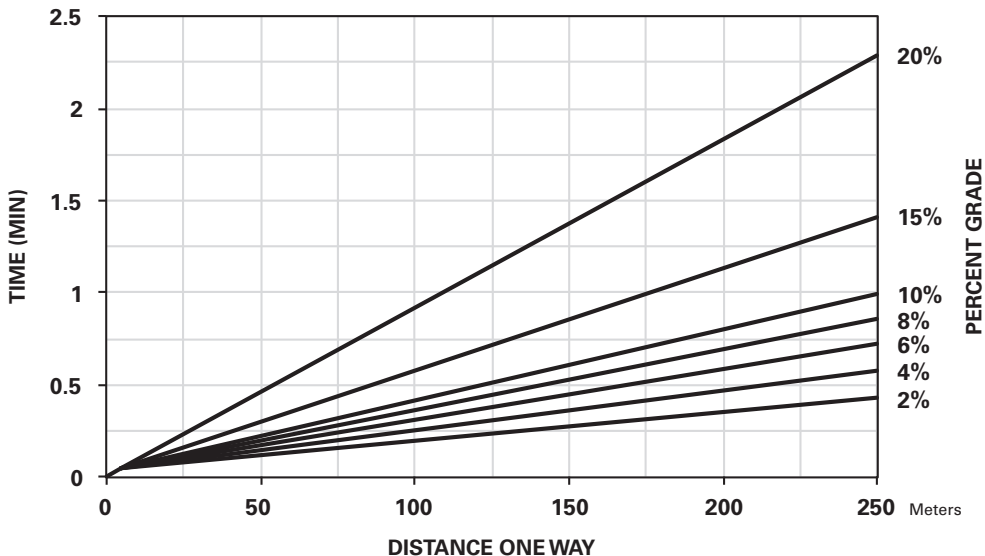

**972M XE TRAVEL TIME — EMPTY**

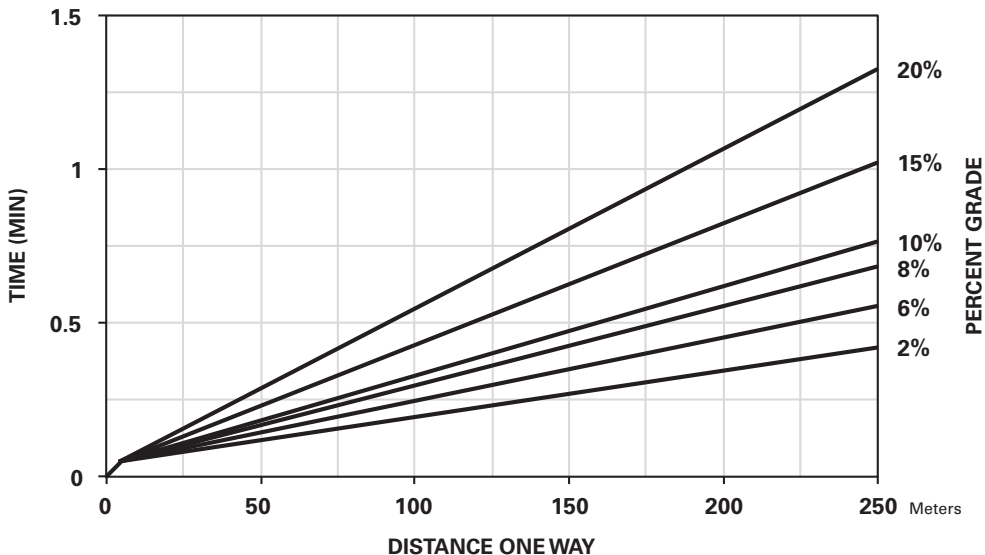

Curves assume use of highest operating speed attainable.

In load-and-carry applications it is important to consult the tire manufacturer on load-speed ratings and pressure recommendations.

Meets Tier 4 Final, Stage IV and Japan 2014 (Tier 4 Final) emission standards.

**980M TRAVEL TIME — LOADED**

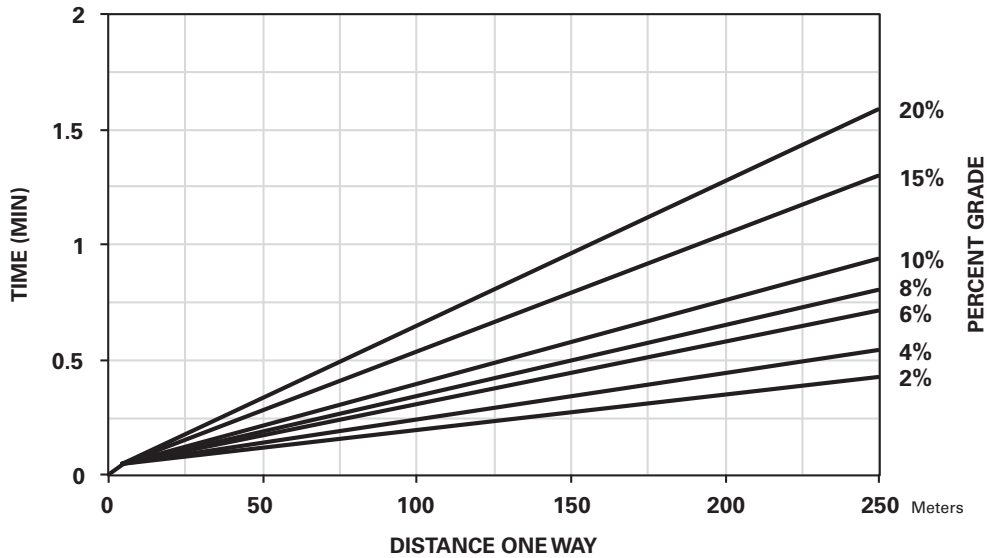

**980M TRAVEL TIME — EMPTY**

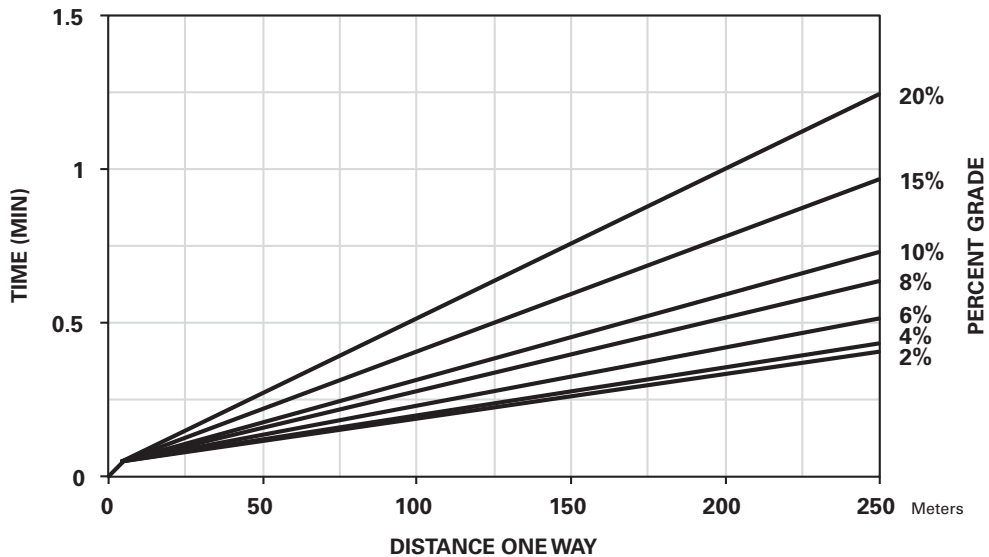

Curves assume use of highest operating speed attainable.

In load-and-carry applications it is important to consult the tire manufacturer on load-speed ratings and pressure recommendations.

Meets Tier 4 Final, Stage IV and Japan 2014 (Tier 4 Final) emission standards.

**Wheel Loaders  
Integrated Toolcarriers**

**Travel Time — Loaded and Empty**

- 982M
- 875/65R29 L4 Tires

**982M TRAVEL TIME — LOADED**

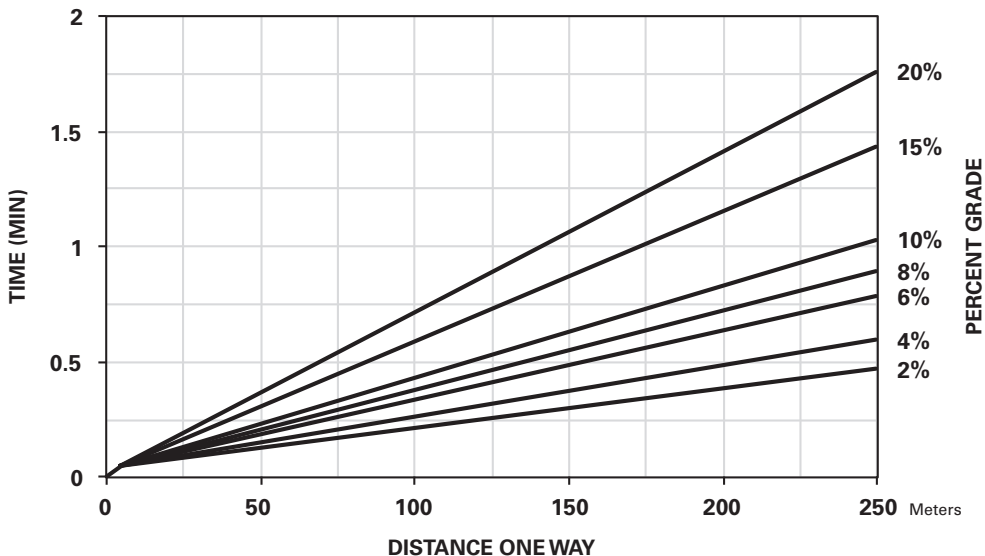

**982M TRAVEL TIME — EMPTY**

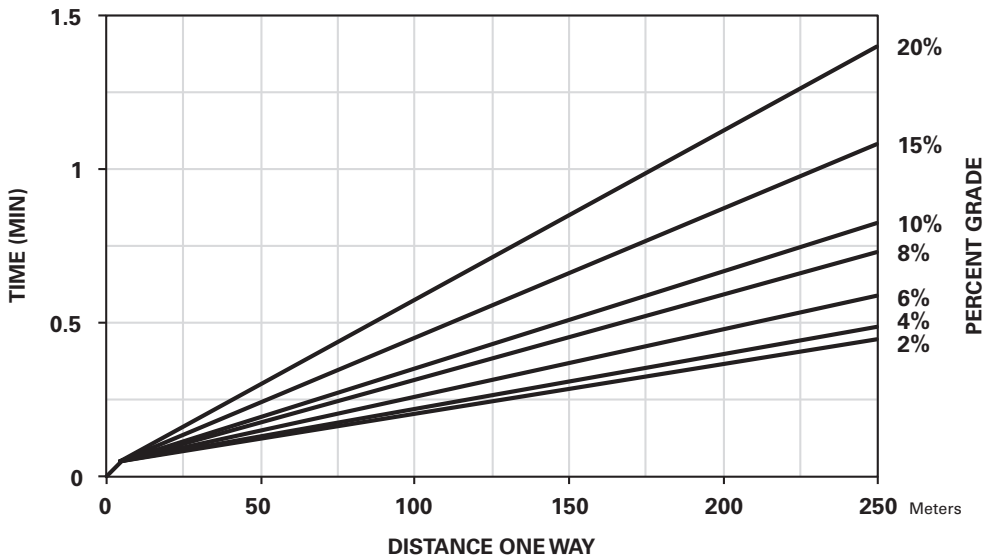

Curves assume use of highest operating speed attainable.

In load-and-carry applications it is important to consult the tire manufacturer on load-speed ratings and pressure recommendations.

Meets Tier 4 Final, Stage IV and Japan 2014 (Tier 4 Final) emission standards.

### 950K TRAVEL TIME — LOADED

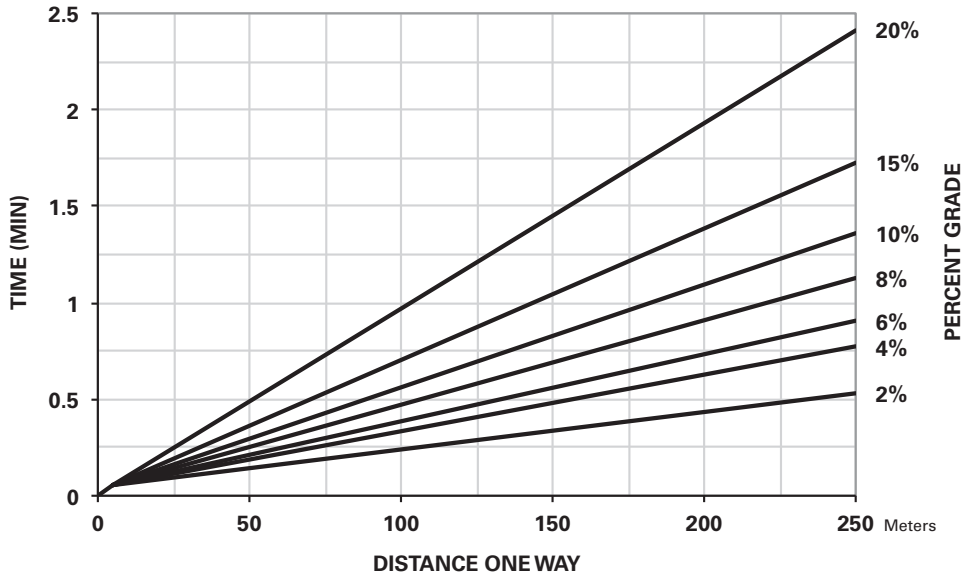

### 950K TRAVEL TIME — EMPTY

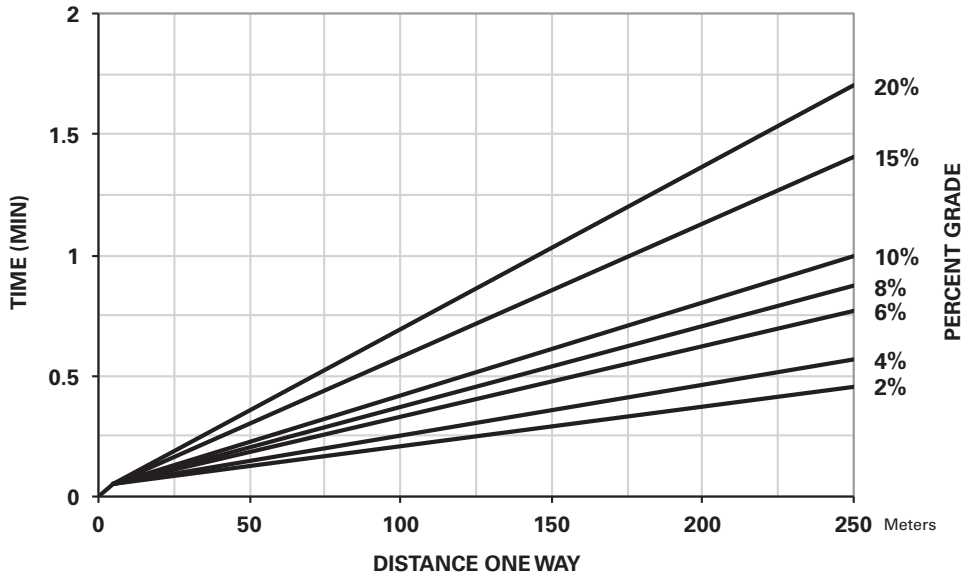

Contact your local Cat dealer for product availability.

Curves assume use of highest operating speed attainable.

In load-and-carry applications it is important to consult the tire manufacturer on load-speed ratings and pressure recommendations.

# Wheel Loaders Integrated Toolcarriers

## Travel Time — Loaded and Empty

- 962K
- 23.5-R25 Tires

### 962K TRAVEL TIME — LOADED

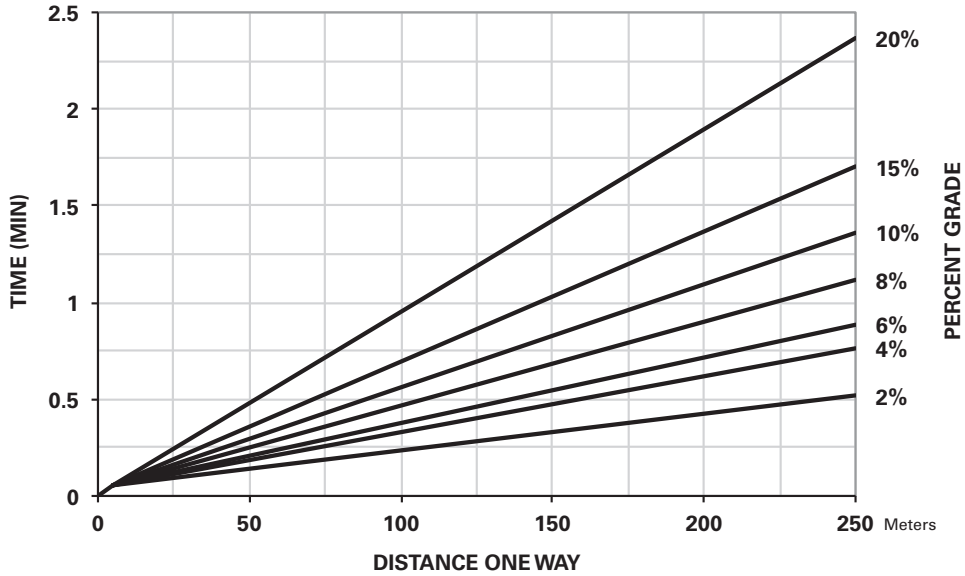

### 962K TRAVEL TIME — EMPTY

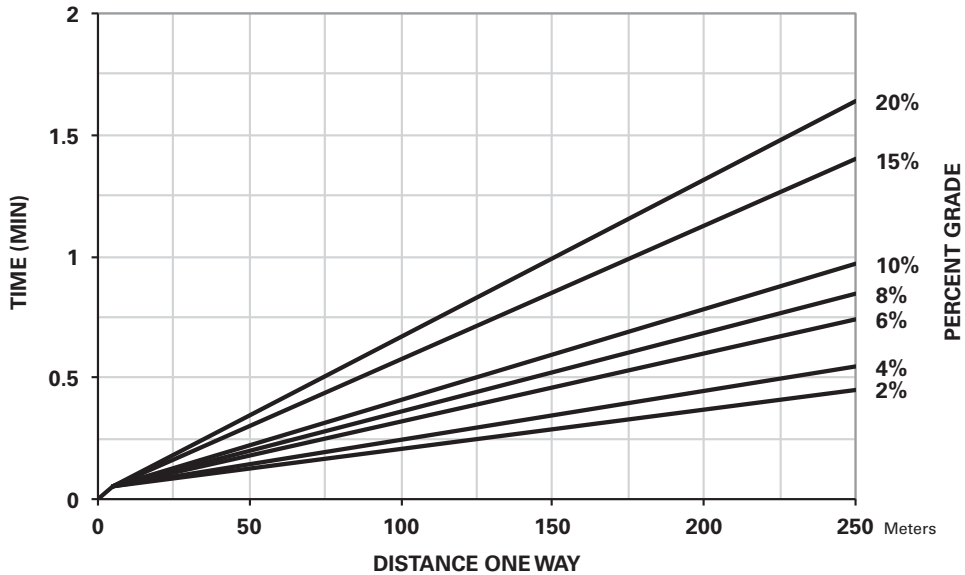

Contact your local Cat dealer for product availability.

Curves assume use of highest operating speed attainable.

In load-and-carry applications it is important to consult the tire manufacturer on load-speed ratings and pressure recommendations.

**966K TRAVEL TIME — LOADED**

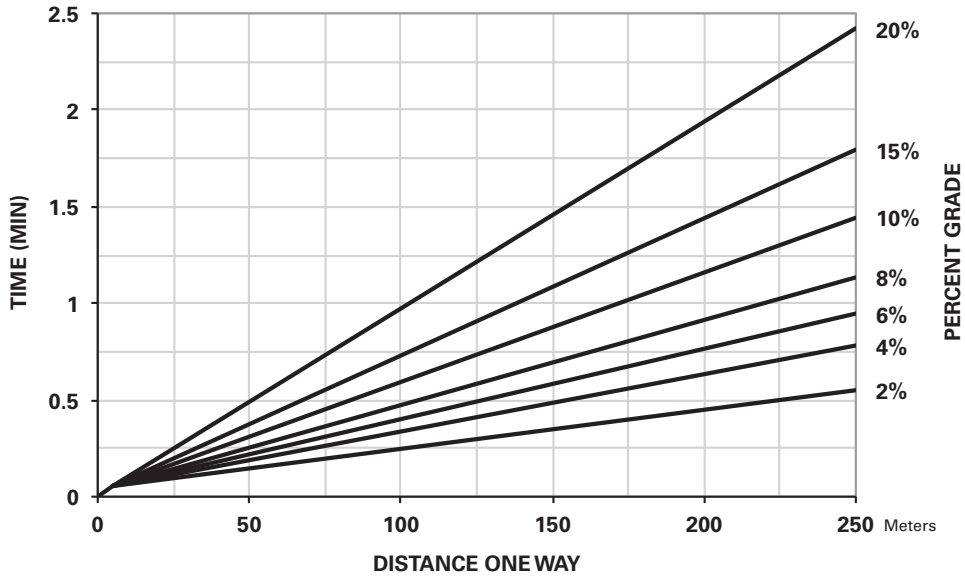

**966K TRAVEL TIME — EMPTY**

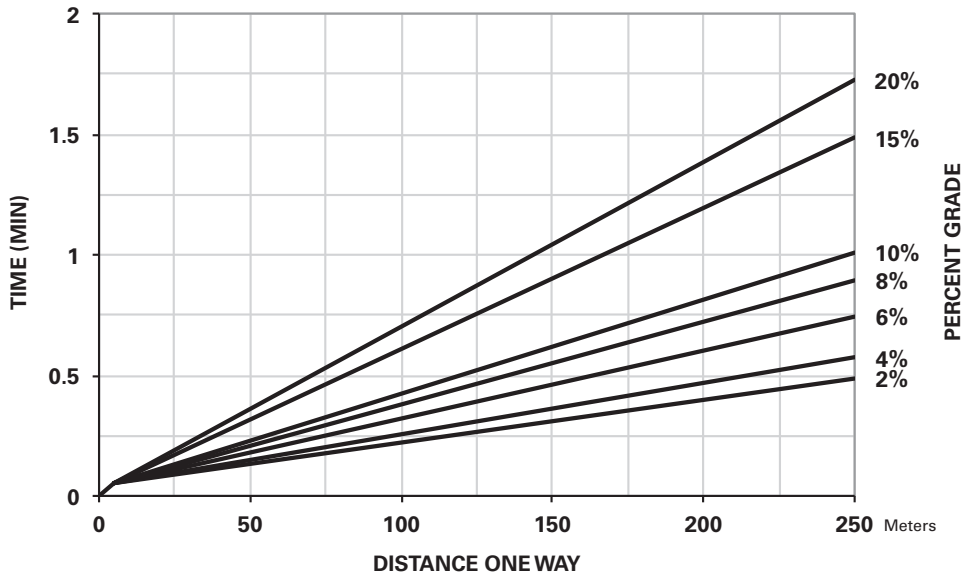

Contact your local Cat dealer for product availability.

Curves assume use of highest operating speed attainable.

In load-and-carry applications it is important to consult the tire manufacturer on load-speed ratings and pressure recommendations.



# Wheel Loaders Integrated Toolcarriers

## Travel Time — Loaded and Empty

- 972K
- 26.5-R25 Tires

### 972K TRAVEL TIME — LOADED

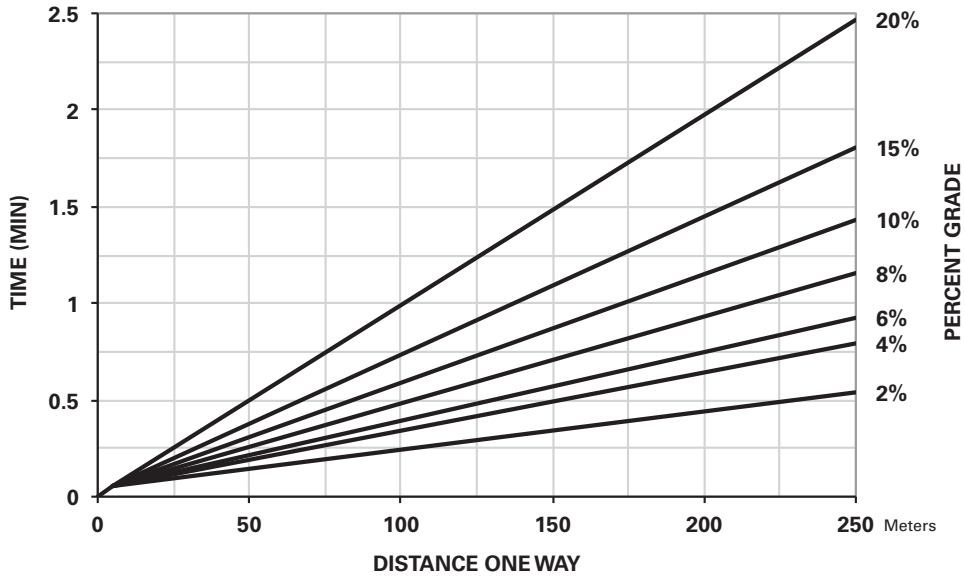

### 972K TRAVEL TIME — EMPTY

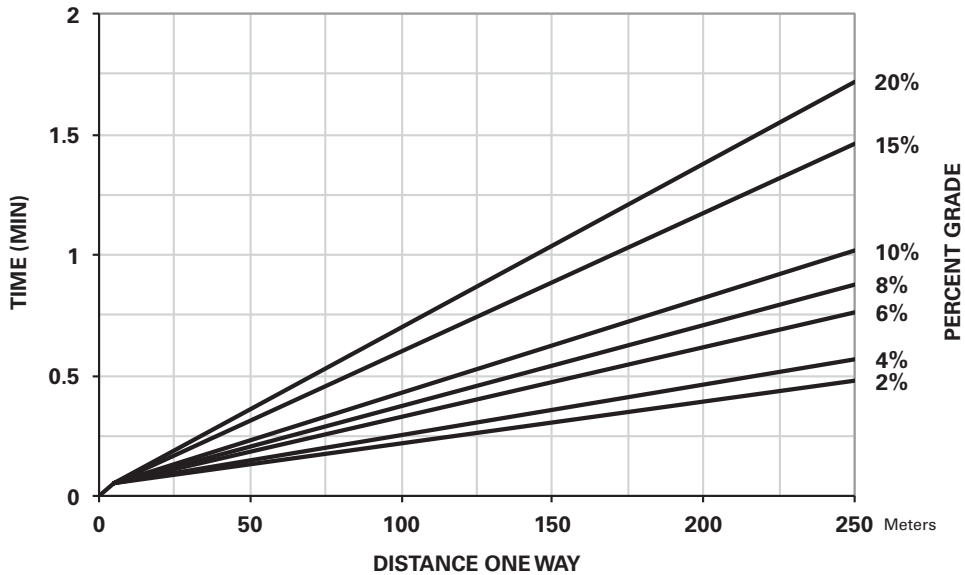

Contact your local Cat dealer for product availability.

Curves assume use of highest operating speed attainable.

In load-and-carry applications it is important to consult the tire manufacturer on load-speed ratings and pressure recommendations.

- 980K
- 29.5-R25 Tires

**980K (NO LOCK-UP) TRAVEL TIME — LOADED**

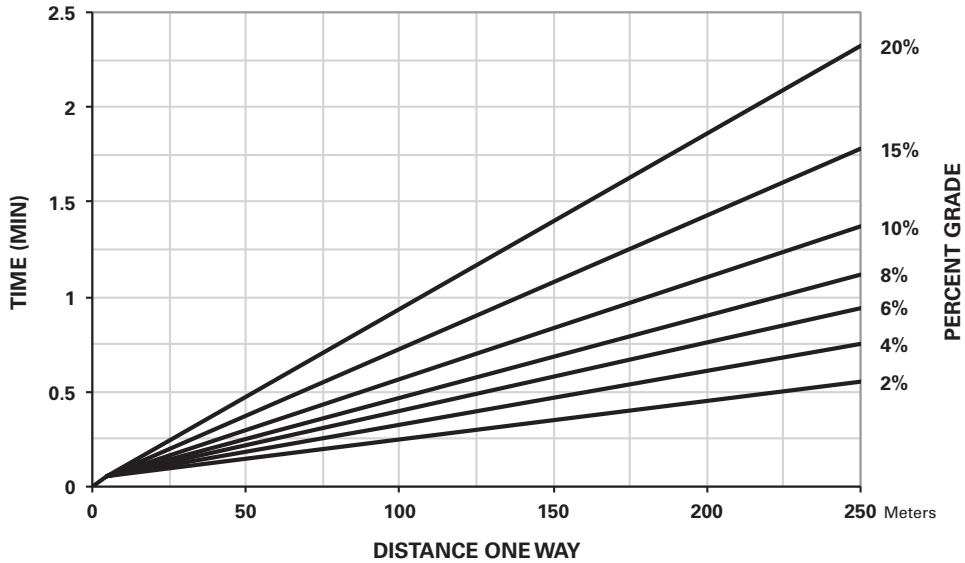

**980K (NO LOCK-UP) TRAVEL TIME — EMPTY**

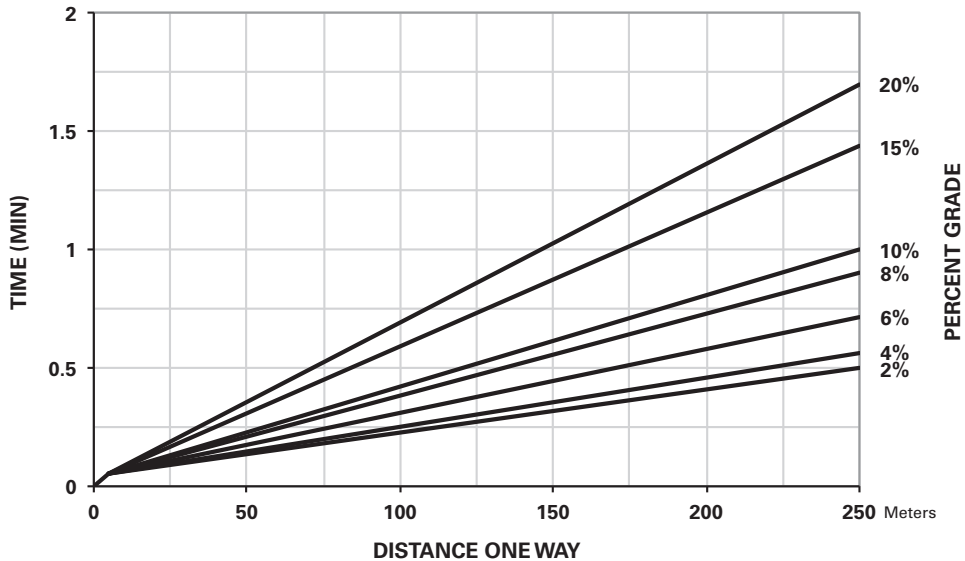

Contact your local Cat dealer for product availability.

Curves assume use of highest operating speed attainable.

In load-and-carry applications it is important to consult the tire manufacturer on load-speed ratings and pressure recommendations.

# Wheel Loaders Integrated Toolcarriers

Travel Time (Lock-Up Clutch) — Loaded and Empty

- 980K
- 29.5-R25 Tires

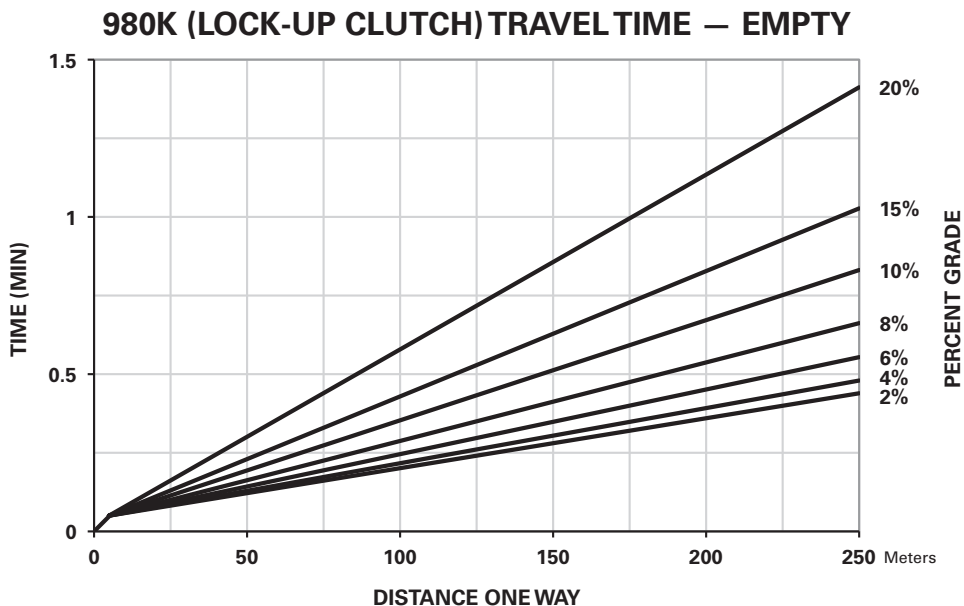
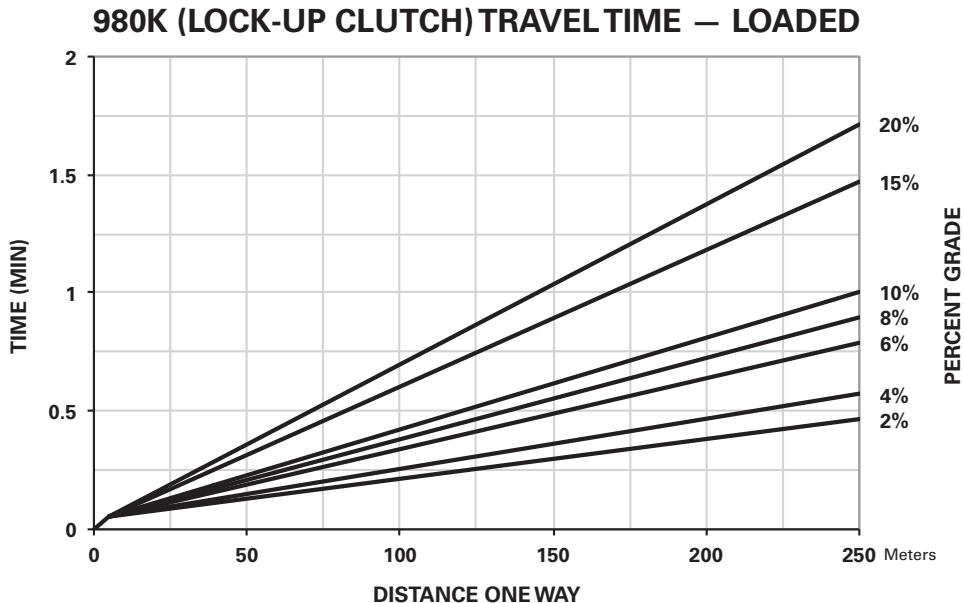

Contact your local Cat dealer for product availability.

Curves assume use of highest operating speed attainable.

In load-and-carry applications it is important to consult the tire manufacturer on load-speed ratings and pressure recommendations.

**950 GC TRAVEL TIME — LOADED**

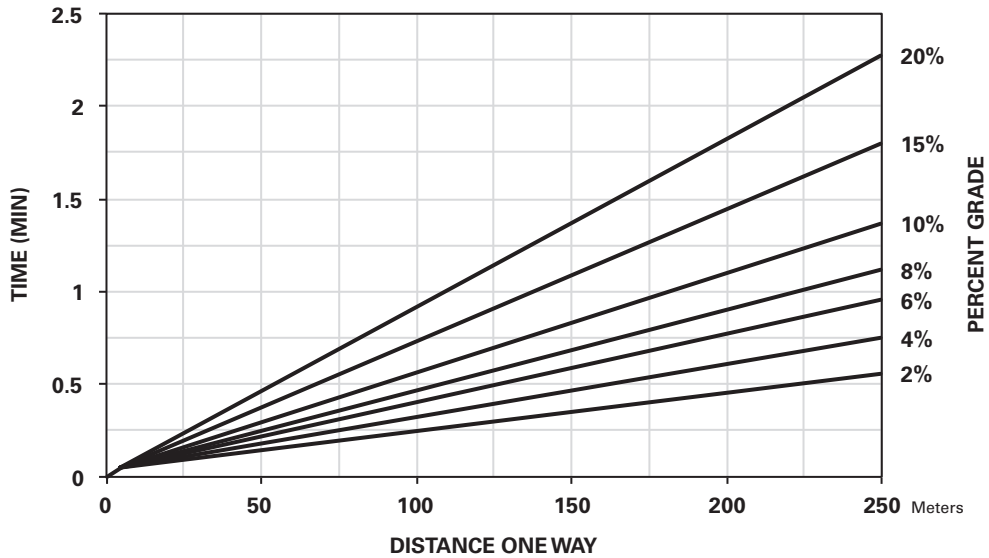

**950 GC TRAVEL TIME — EMPTY**

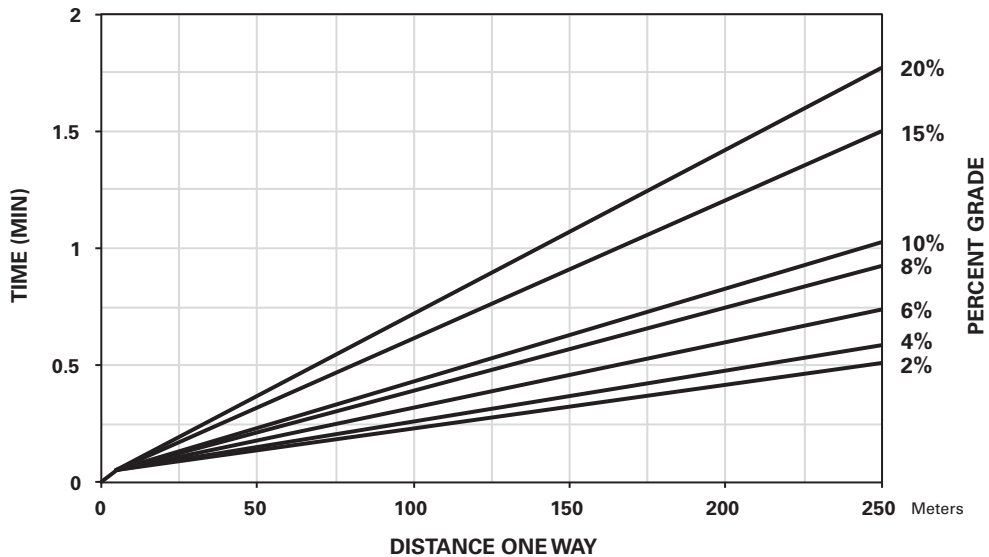

Curves assume use of highest operating speed attainable.

In load-and-carry applications it is important to consult the tire manufacturer on load-speed ratings and pressure recommendations.

Meets Tier 3, Stage IIIA, Japan 2006 (Tier 3) equivalent emission standards.

- 950L/950M
- 23.5R25 Tires

**950L/950M TRAVEL TIME — LOADED**

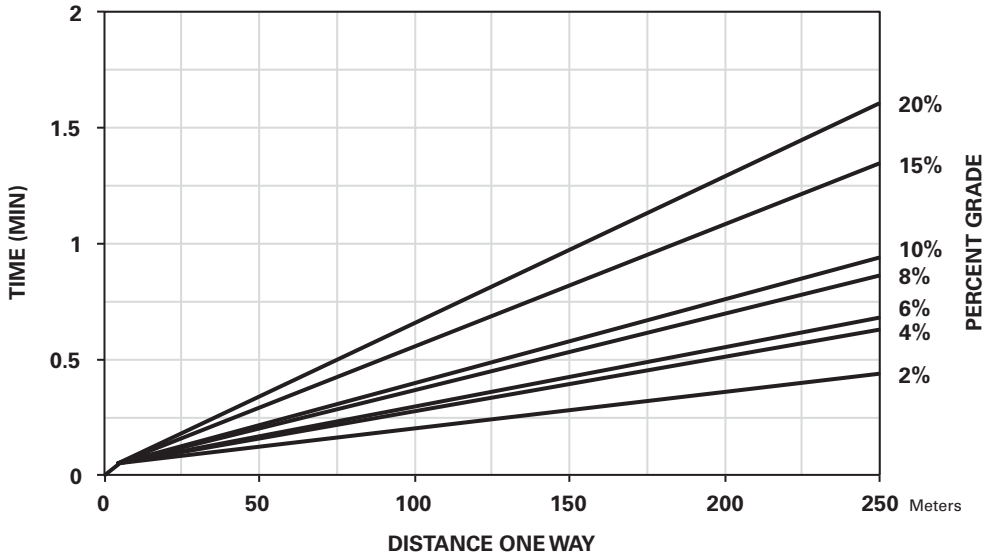

**950L/950M TRAVEL TIME — EMPTY**

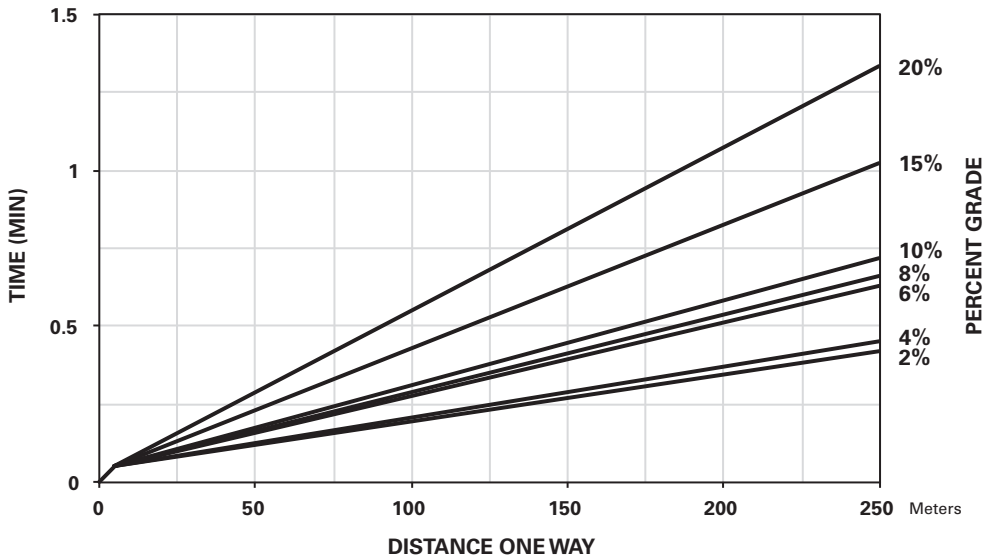

Curves assume use of highest operating speed attainable.

In load-and-carry applications it is important to consult the tire manufacturer on load-speed ratings and pressure recommendations.

Meets Tier 3, Stage IIIA, Japan 2006 (Tier 3) equivalent emission standards.

**962L/962M TRAVEL TIME — LOADED**

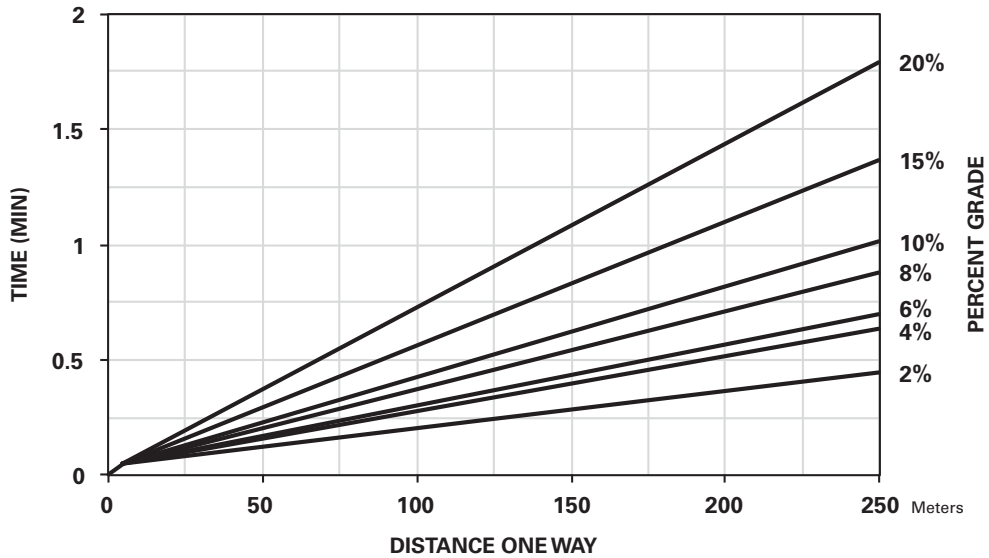

**962L/962M TRAVEL TIME — EMPTY**

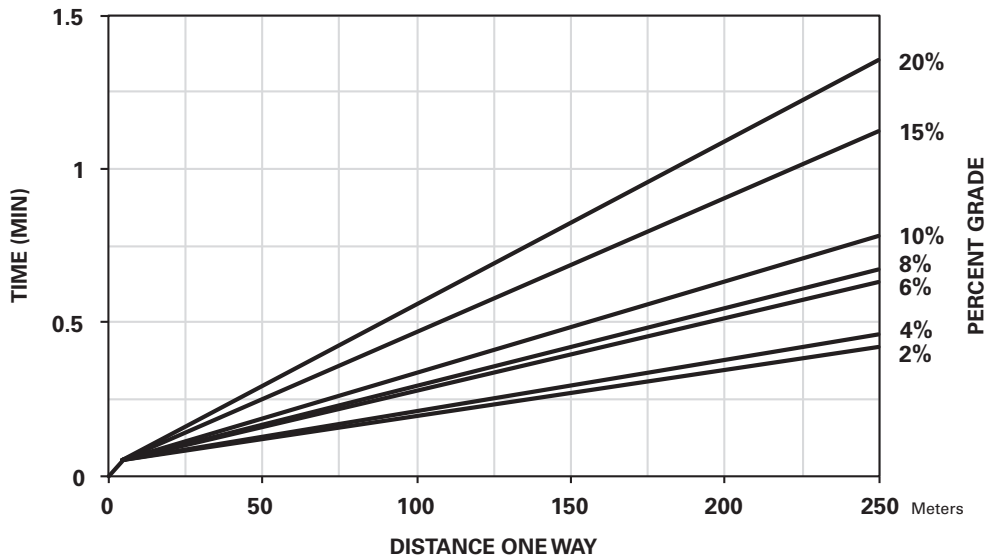

Curves assume use of highest operating speed attainable.

In load-and-carry applications it is important to consult the tire manufacturer on load-speed ratings and pressure recommendations.

Meets Tier 3, Stage IIIA, Japan 2006 (Tier 3) equivalent emission standards.

- 966L/966M
- 26.5R25 Tires

**966L/966M TRAVEL TIME — LOADED**

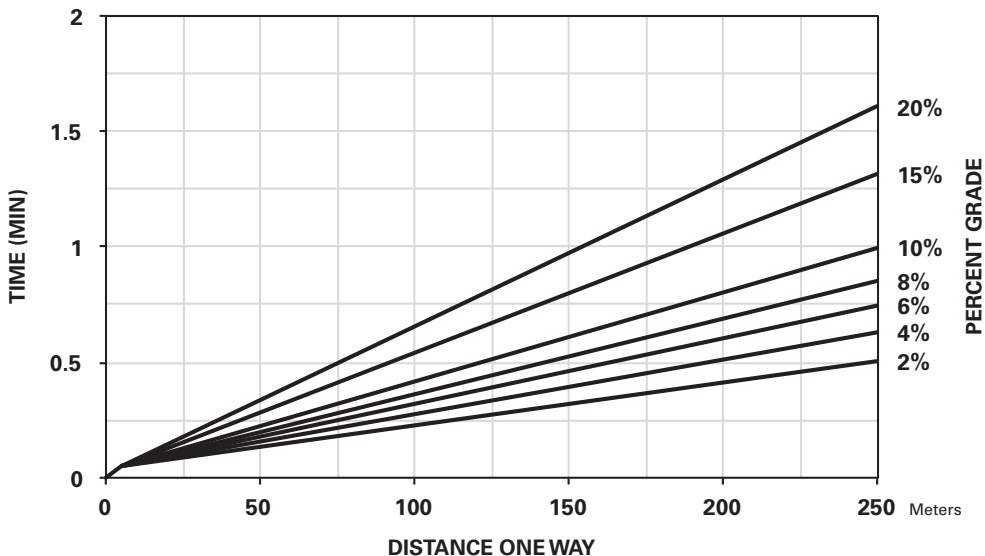

**966L/966M TRAVEL TIME — EMPTY**

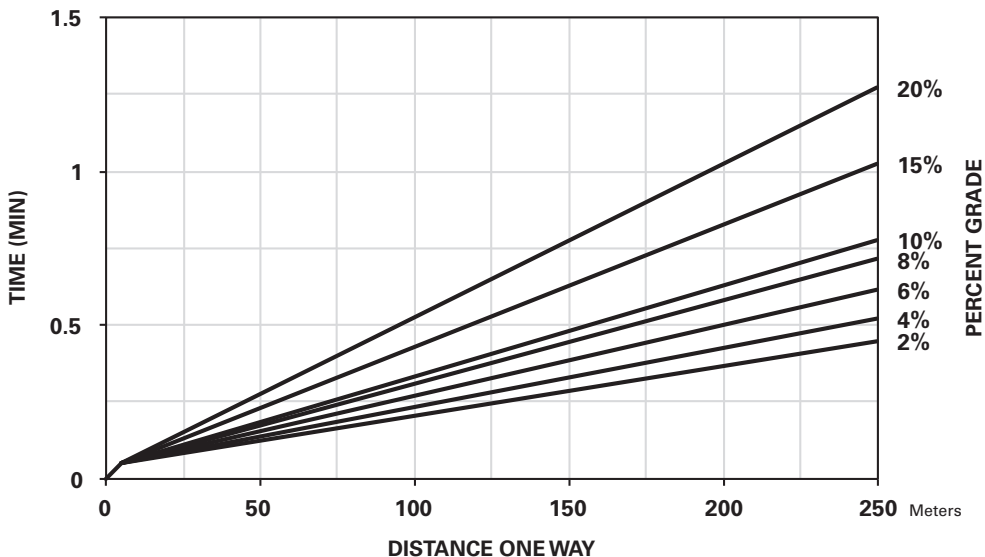

Curves assume use of highest operating speed attainable.

In load-and-carry applications it is important to consult the tire manufacturer on load-speed ratings and pressure recommendations.

Meets Tier 2/Stage II/Japan 2001 (Tier 2) equivalent OR Tier 3/Stage IIIA/Japan 2006 (Tier 3) equivalent emission standards.

**972L/972M TRAVEL TIME — LOADED**

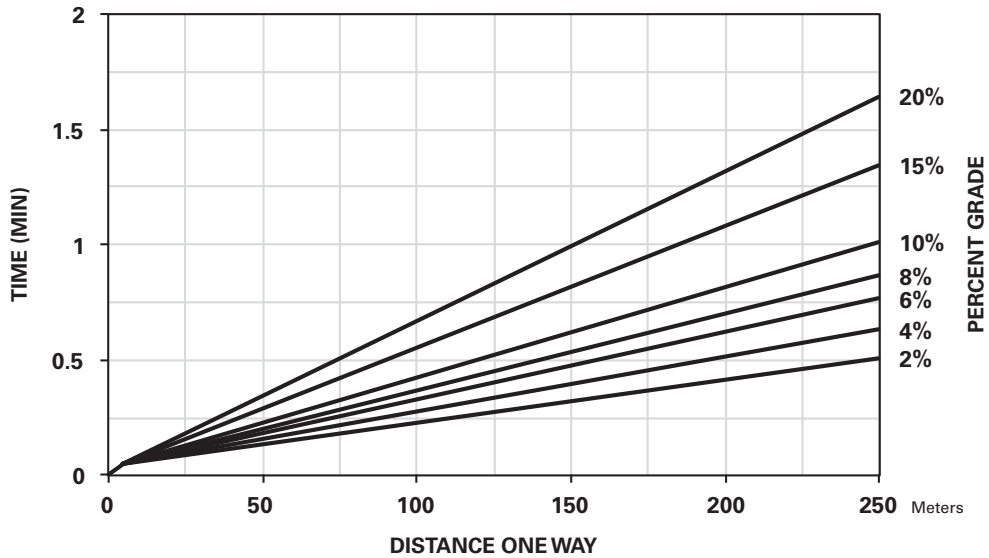

**972L/972M TRAVEL TIME — EMPTY**

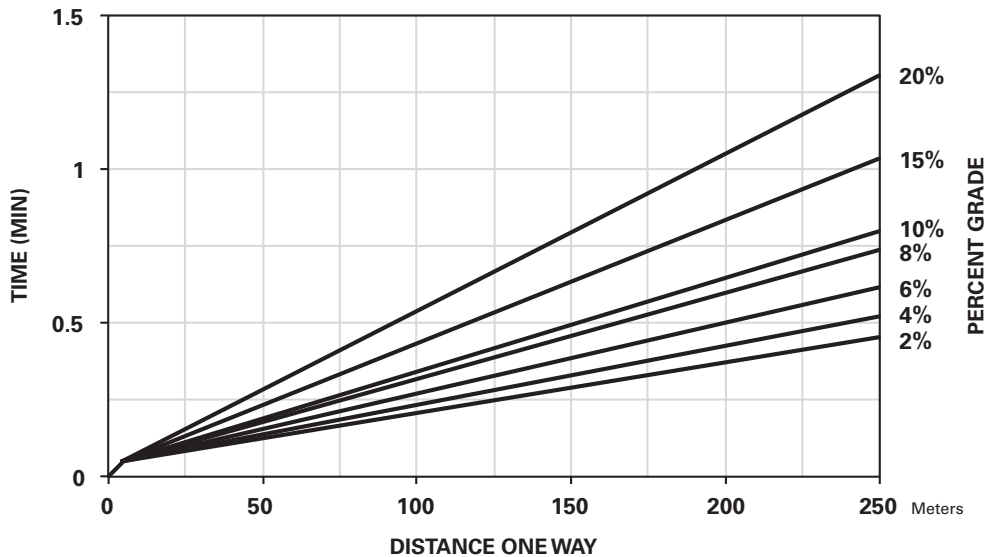

Curves assume use of highest operating speed attainable.

In load-and-carry applications it is important to consult the tire manufacturer on load-speed ratings and pressure recommendations.

Meets Tier 2/Stage II/Japan 2001 (Tier 2) equivalent OR Tier 3/Stage IIIA/Japan 2006 (Tier 3) equivalent emission standards.



- 980L/980M
- 29.5R25 L4 Tires

**980L/980M TRAVEL TIME — LOADED**

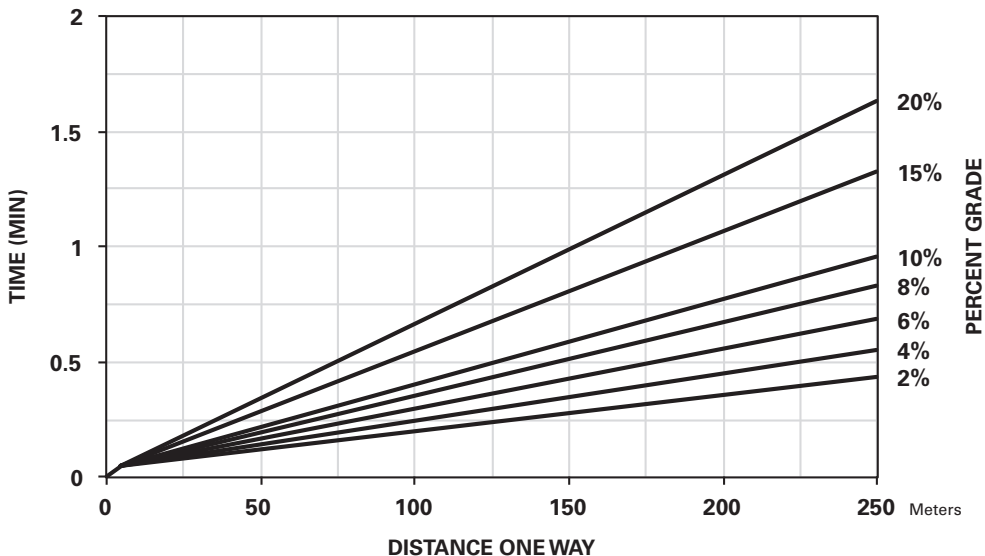

**980L/980M TRAVEL TIME — EMPTY**

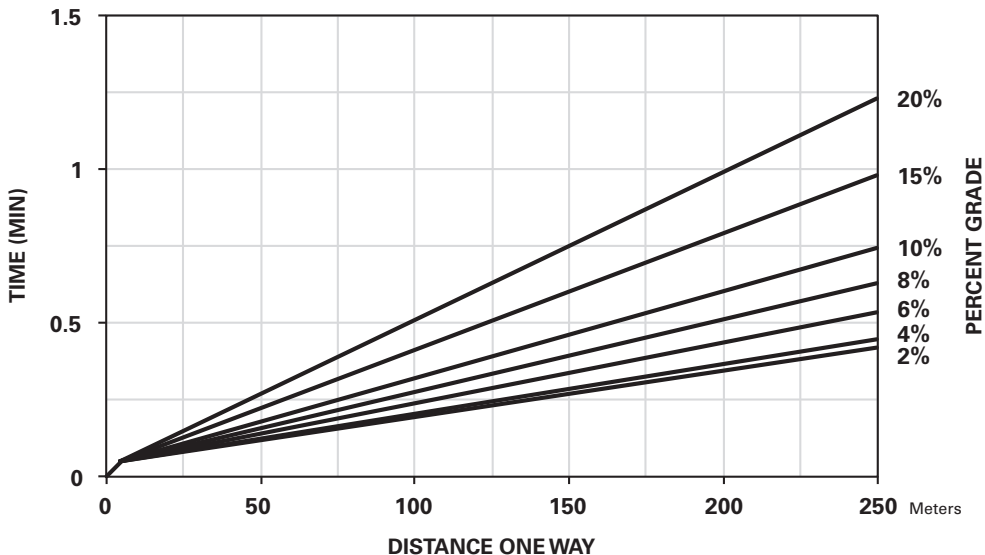

Curves assume use of highest operating speed attainable.

In load-and-carry applications it is important to consult the tire manufacturer on load-speed ratings and pressure recommendations.

Meets Tier 2/Stage II/Japan 2001 (Tier 2) equivalent OR Tier 3/Stage IIIA/Japan 2006 (Tier 3) equivalent emission standards.

**982M TRAVEL TIME — LOADED**

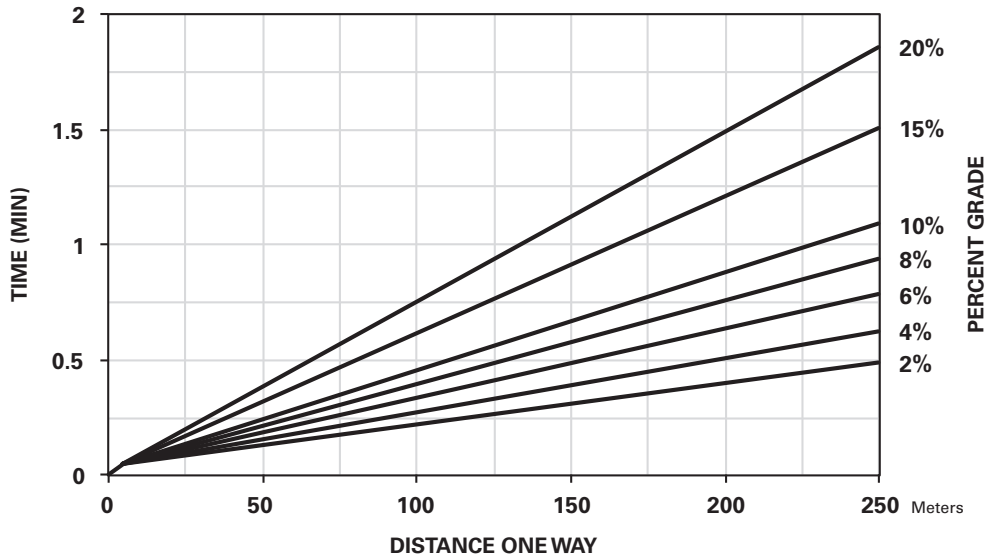

**982M TRAVEL TIME — EMPTY**

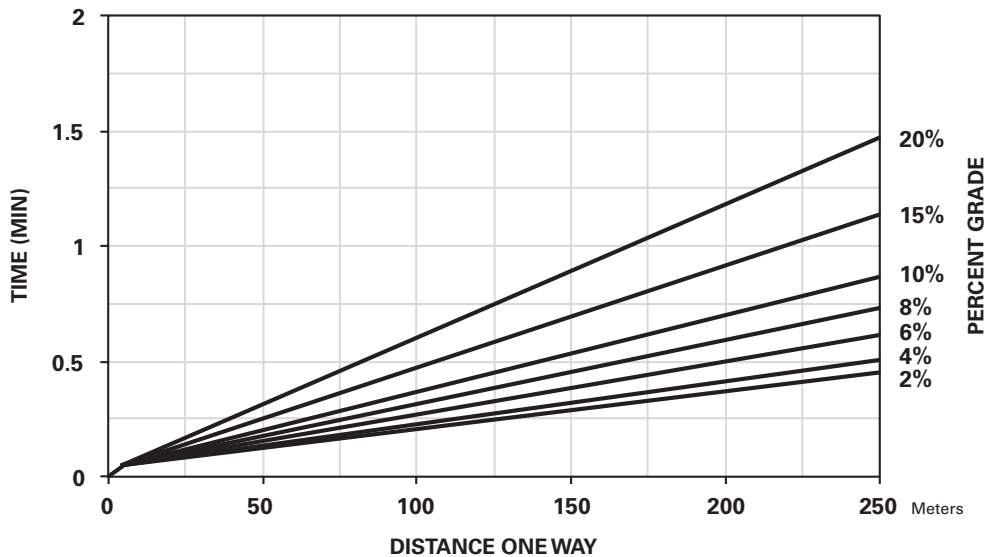

Curves assume use of highest operating speed attainable.

In load-and-carry applications it is important to consult the tire manufacturer on load-speed ratings and pressure recommendations.

Meets Tier 2/Stage II/Japan 2001 (Tier 2) equivalent OR Tier 3/Stage IIIA/Japan 2006 (Tier 3) equivalent emission standards.

# Wheel Loaders Integrated Toolcarriers

## Travel Time — Loaded and Empty

- 950H
- 23.5-R25 Tires

### 950H TRAVEL TIME — LOADED

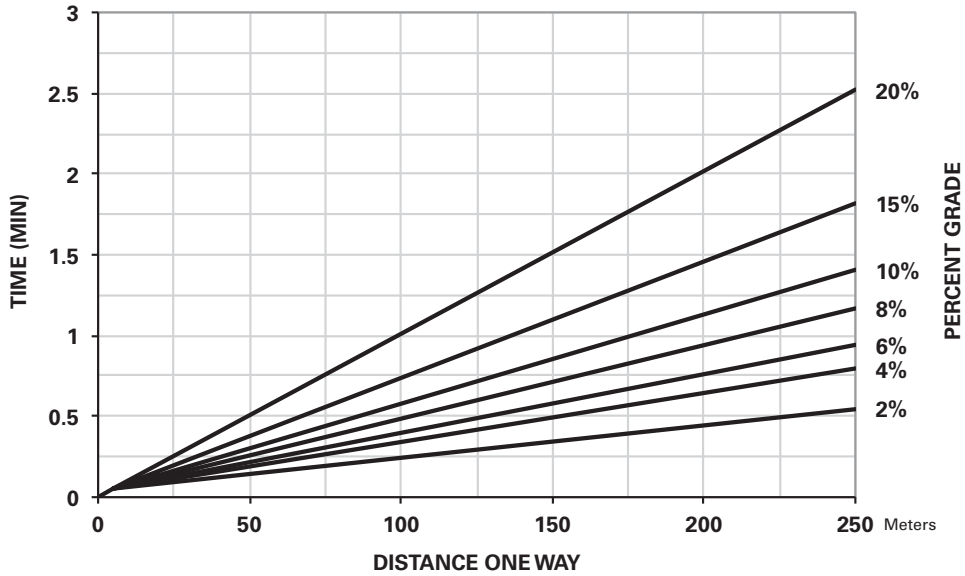

### 950H TRAVEL TIME — EMPTY

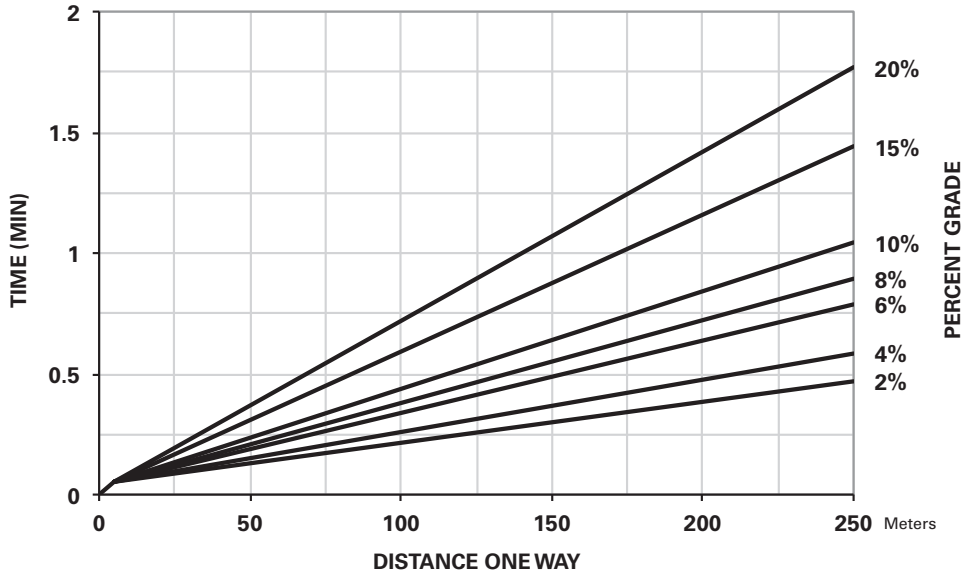

Not available in all regions. Contact your local Cat dealer for product availability.

Curves assume use of highest operating speed attainable.

In load-and-carry applications it is important to consult the tire manufacturer on load-speed ratings and pressure recommendations.

**962H TRAVEL TIME — LOADED**

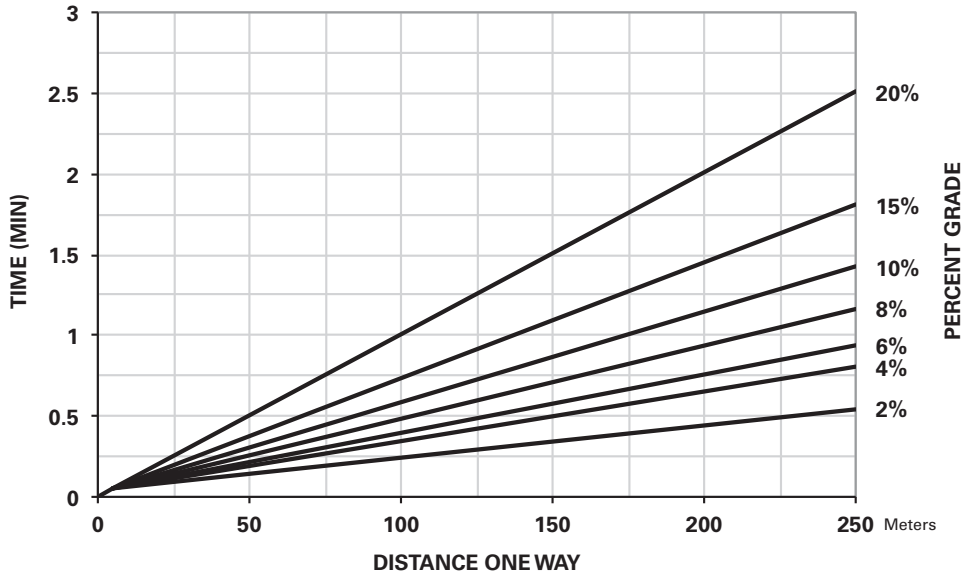

**962H TRAVEL TIME — EMPTY**

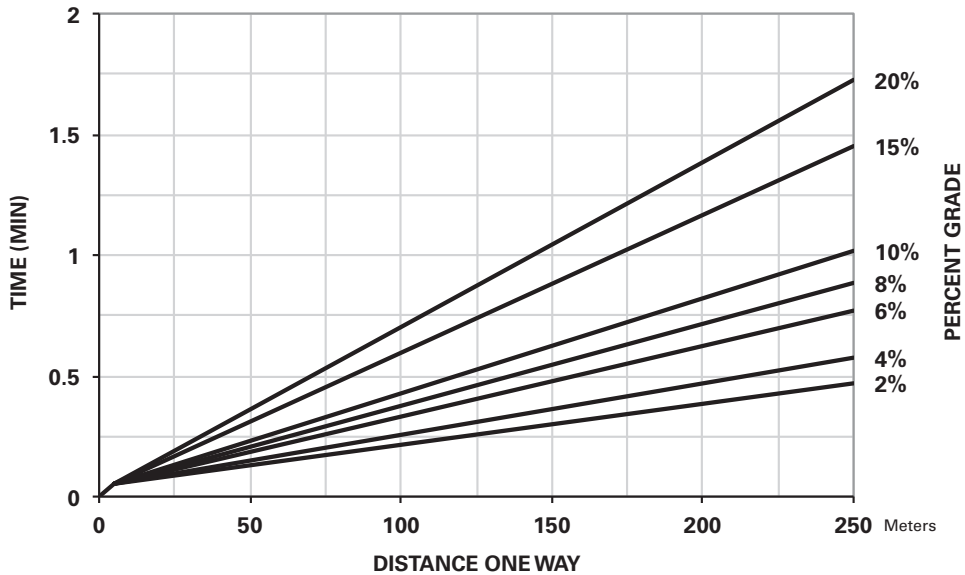

Not available in all regions. Contact your local Cat dealer for product availability.

Curves assume use of highest operating speed attainable.

In load-and-carry applications it is important to consult the tire manufacturer on load-speed ratings and pressure recommendations.

**Wheel Loaders  
Integrated Toolcarriers**

**Travel Time — Loaded and Empty**

- 966H
- 26.5-R25 Tires

**966H TRAVEL TIME — LOADED**

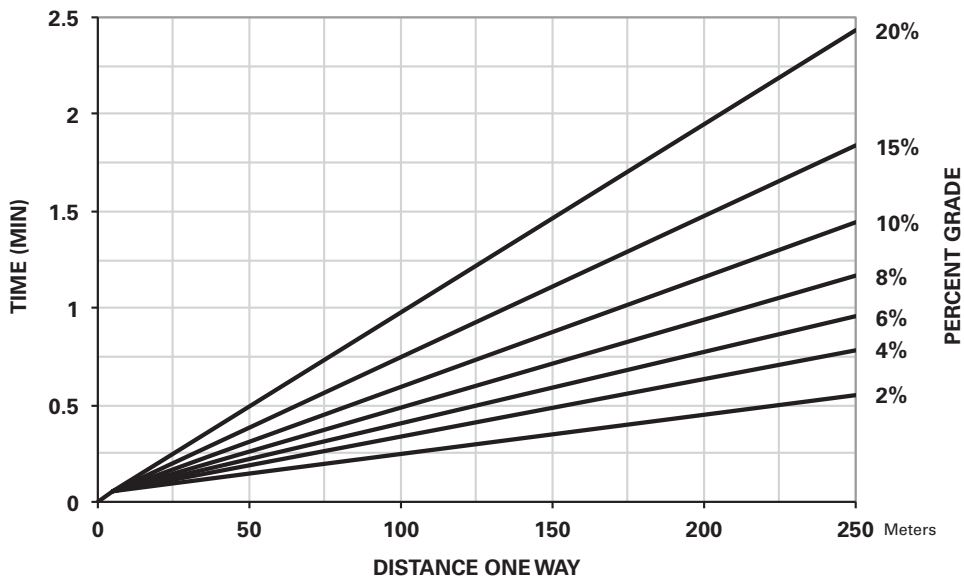

**966H TRAVEL TIME — EMPTY**

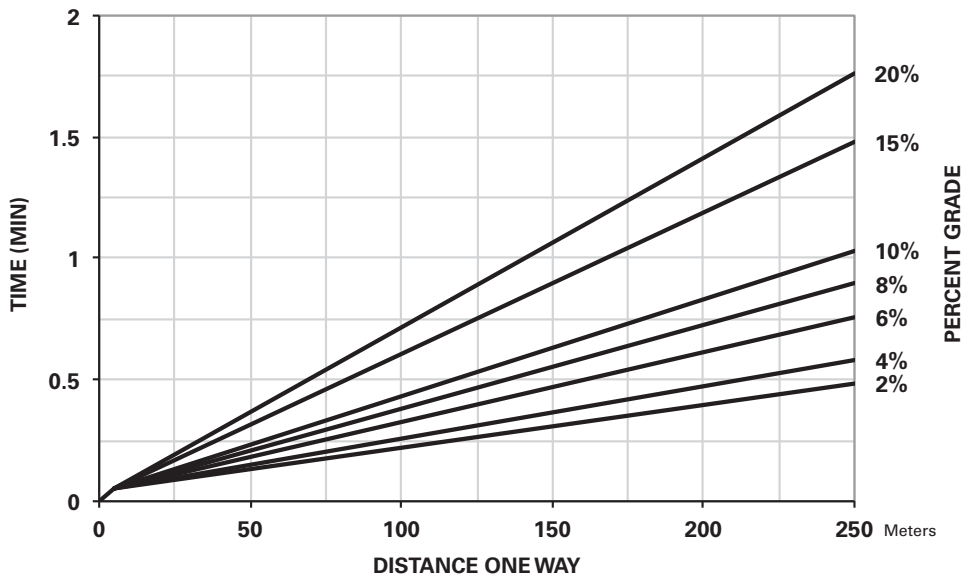

Not available in all regions. Contact your local Cat dealer for product availability.

Curves assume use of highest operating speed attainable.

In load-and-carry applications it is important to consult the tire manufacturer on load-speed ratings and pressure recommendations.

**972H TRAVEL TIME — LOADED**

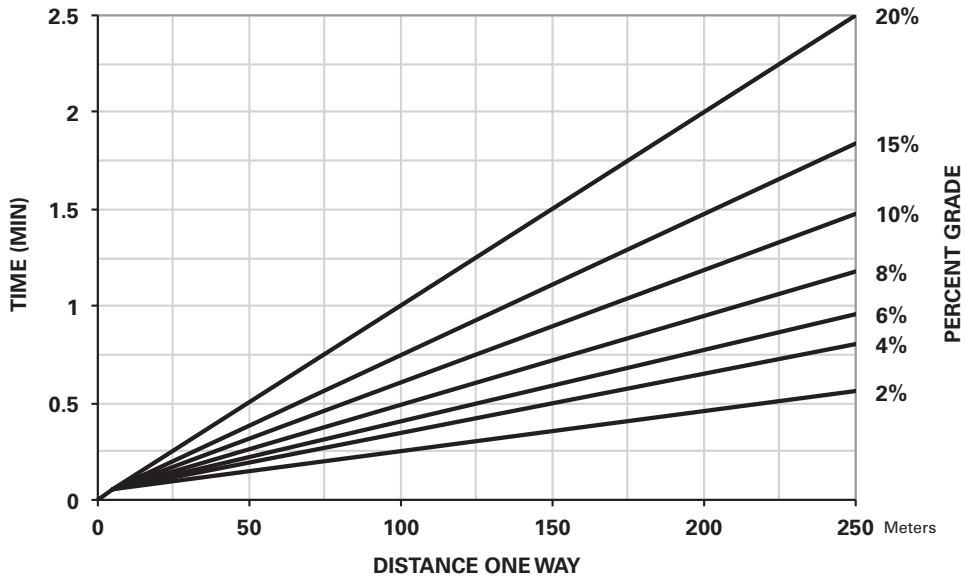

**972H TRAVEL TIME — EMPTY**

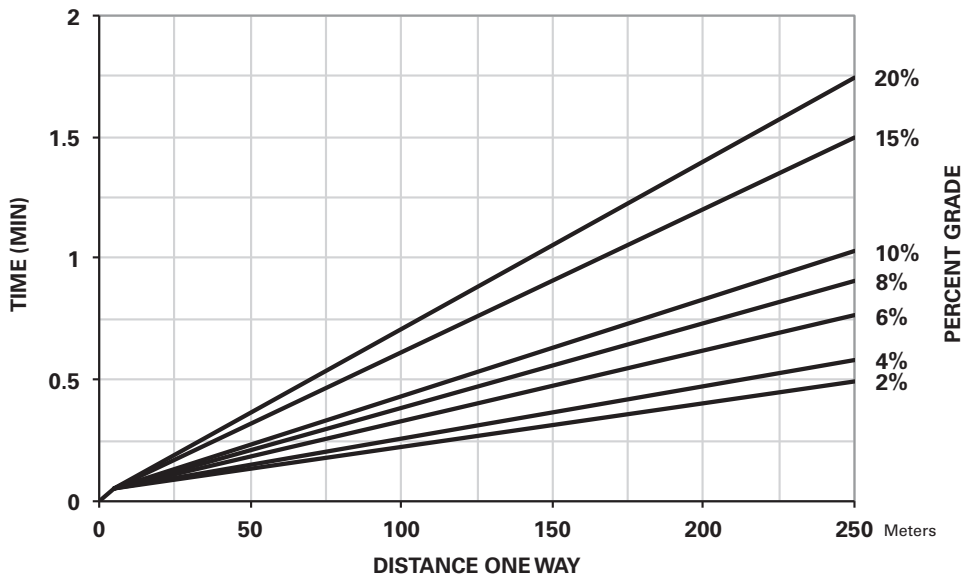

Not available in all regions. Contact your local Cat dealer for product availability.

Curves assume use of highest operating speed attainable.

In load-and-carry applications it is important to consult the tire manufacturer on load-speed ratings and pressure recommendations.

**Wheel Loaders  
Integrated Toolcarriers**

**Travel Time — Loaded and Empty**

- 980H
- 29.5-R25 Tires

**980H TRAVEL TIME — LOADED**

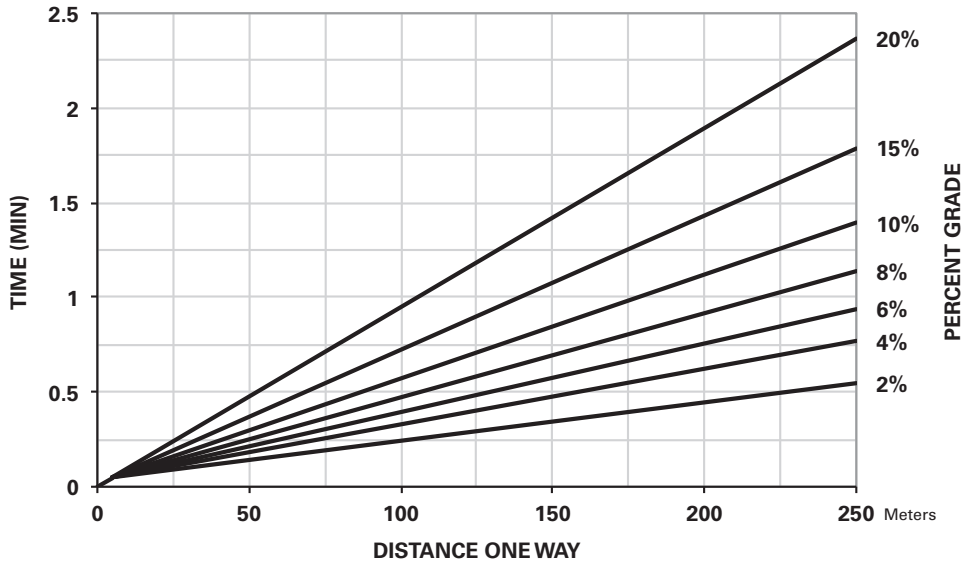

**980H TRAVEL TIME — EMPTY**

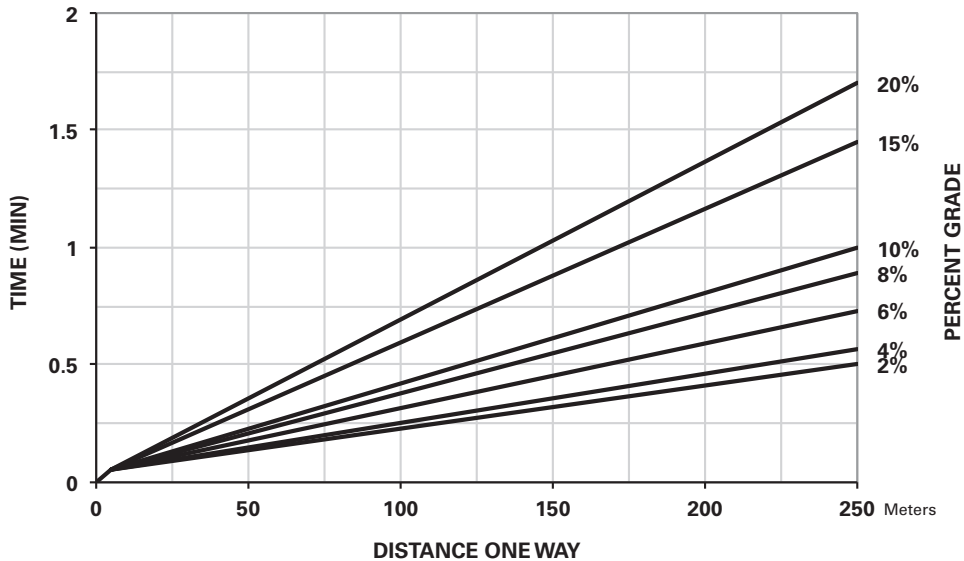

Not available in all regions. Contact your local Cat dealer for product availability.

Curves assume use of highest operating speed attainable.

In load-and-carry applications it is important to consult the tire manufacturer on load-speed ratings and pressure recommendations.

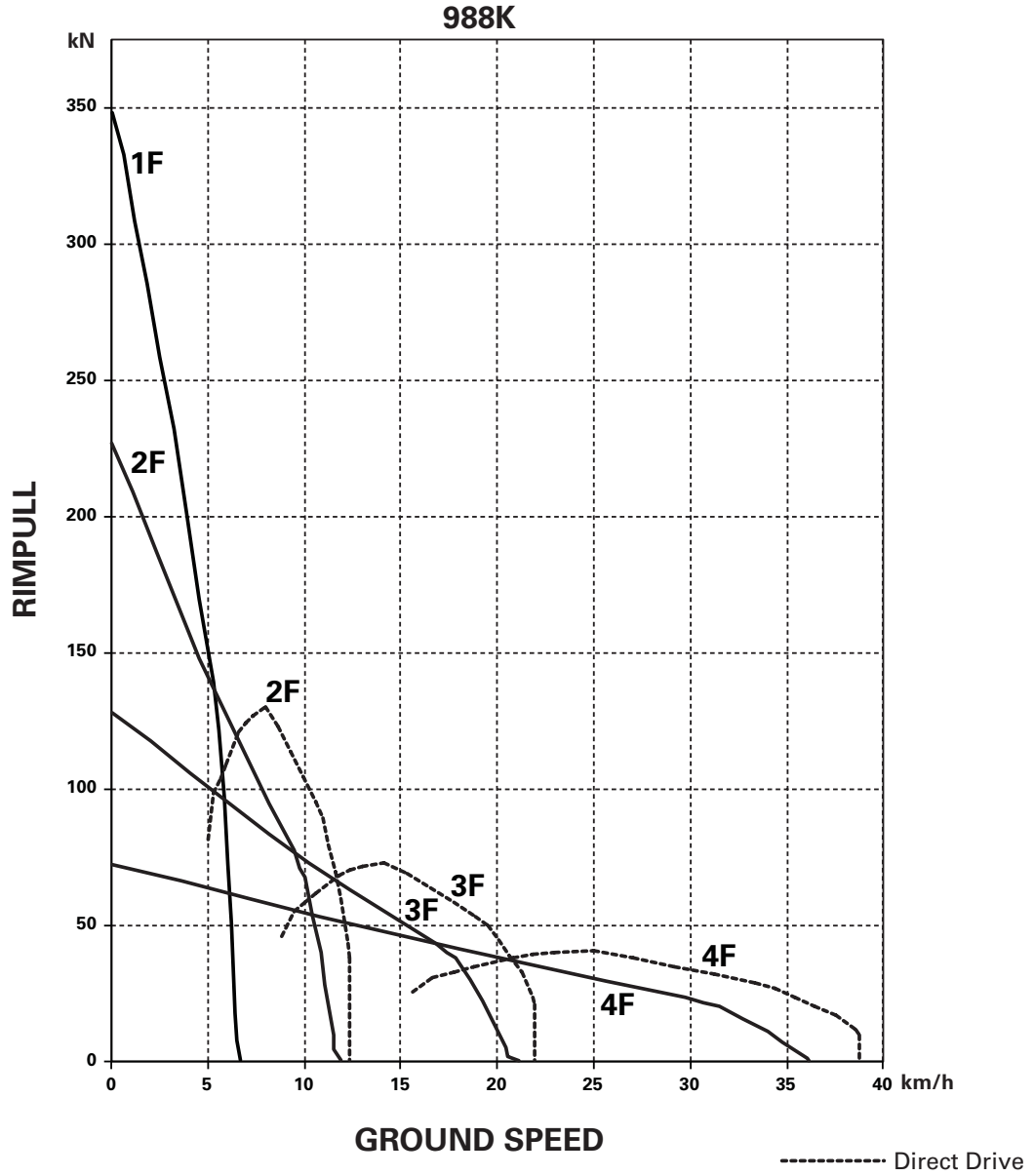



**Wheel Loaders  
Integrated Toolcarriers**

- Travel Time — Loaded**
- 988K — Lock-Up Clutch
  - 35/65-33 Tires

**988K TRAVEL TIME — LOADED**

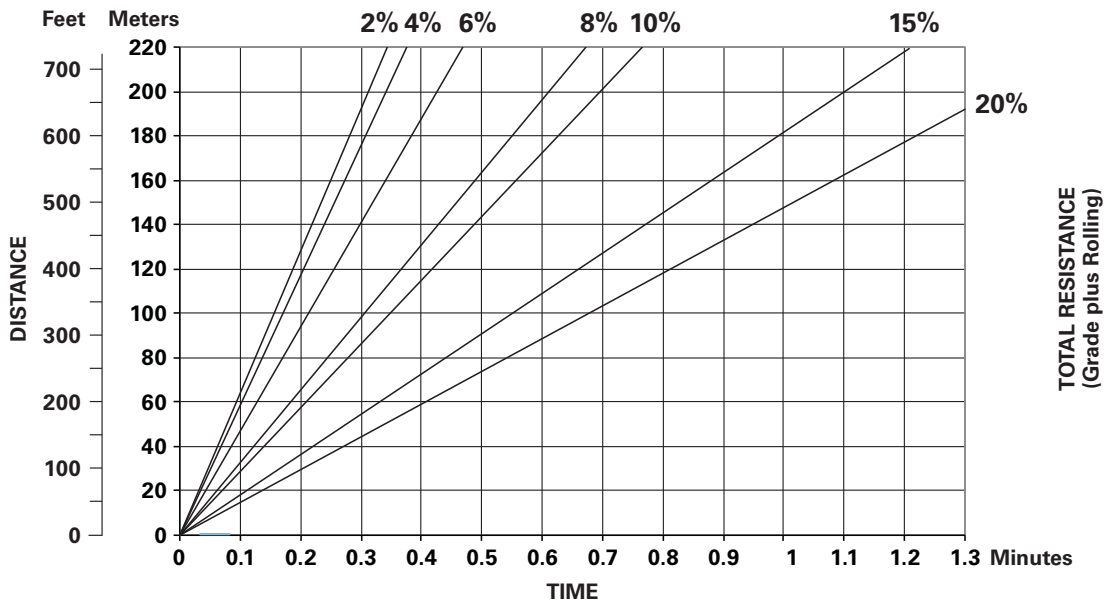

**NOTE:** Curves assume use of highest operating speed attainable: 4th gear for 2%-6% TR, 3rd gear for 8%-10% TR, 2nd gear for 15% and 20% TR.

In load-and-carry applications it is important to consult the tire manufacturer on Ton-MPH ratings and pressure recommendations.

- Travel Time — Empty
- 988K — Lock-Up Clutch
- 35/65-33 Tires

## Wheel Loaders Integrated Toolcarriers

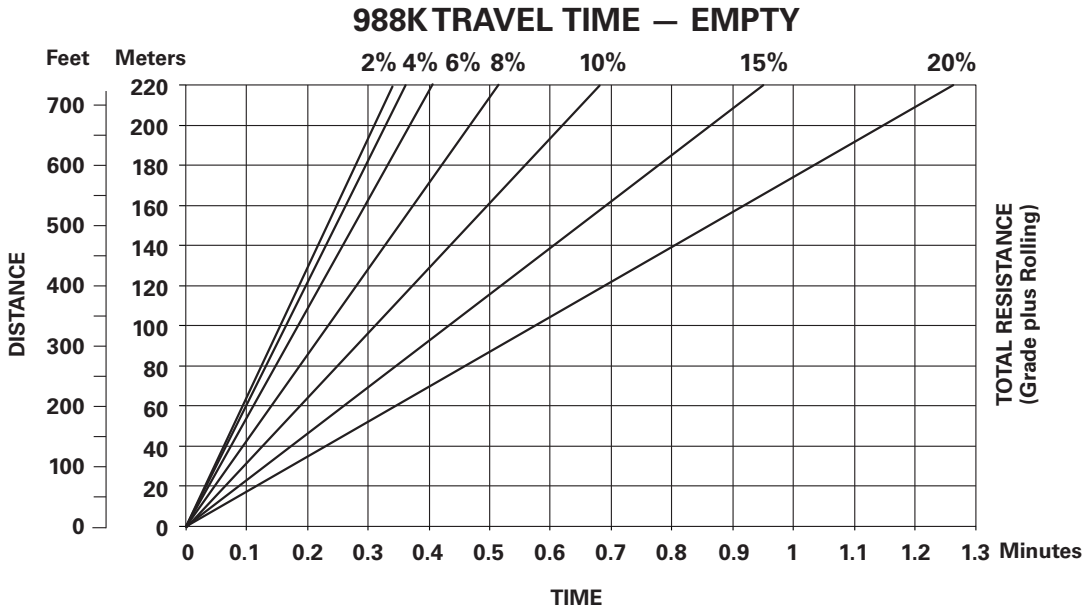

**NOTE:** Curves assume use of highest operating speed attainable: 4th gear for 2%-8% TR, 3rd gear for 10%-15% TR, 2nd gear for 20% TR.

In load-and-carry applications it is important to consult the tire manufacturer on Ton-MPH ratings and pressure recommendations.

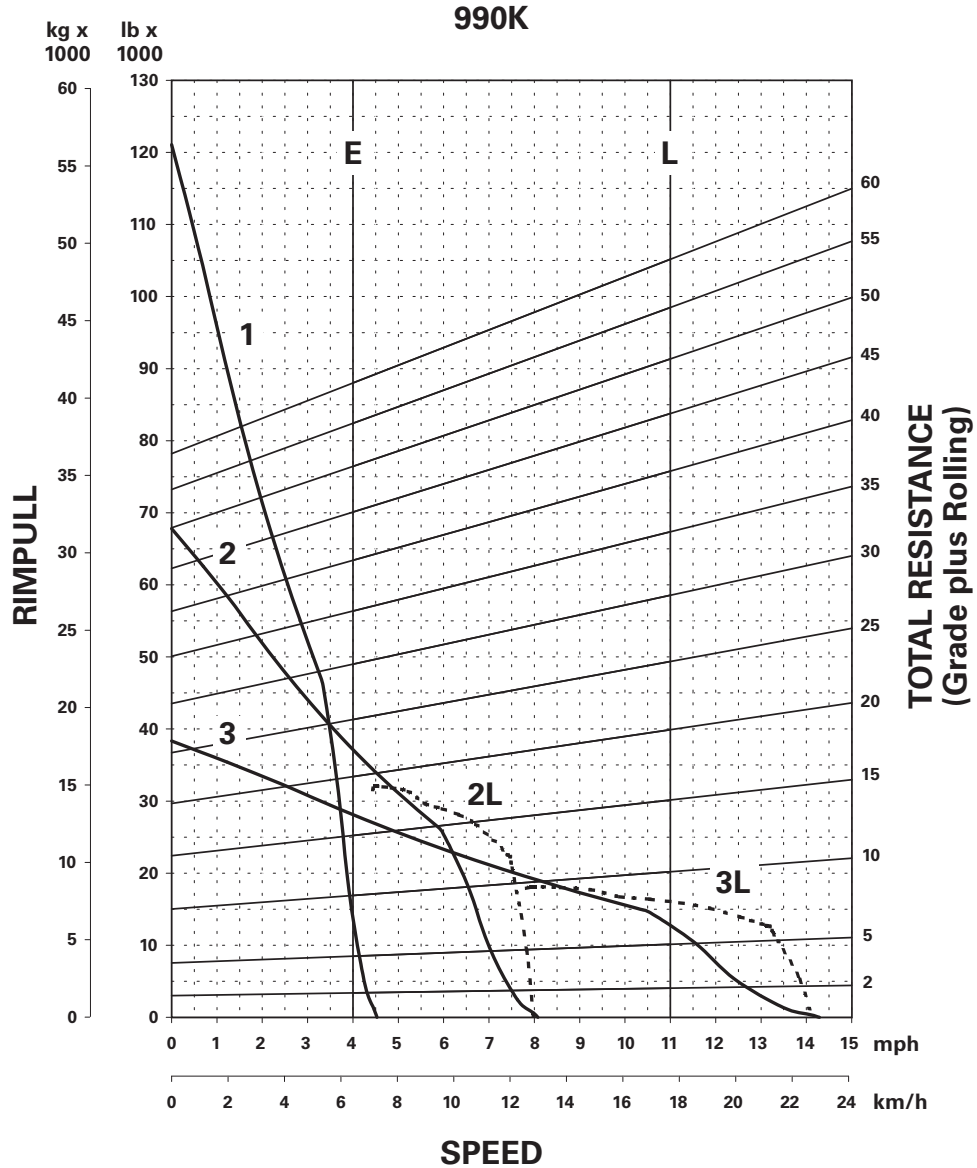

**KEY**

- 1 — 1st Gear
- 2 — 2nd Gear
- 3 — 3rd Gear

**KEY**

- E — Empty 80 974 kg (178,517 lb)
- L — Loaded 96 849 kg (213,515 lb)

Calculated Pull: Idle Hydraulics  
Curves Assume NO SLIP Conditions

### 990K TRAVEL TIME — LOADED

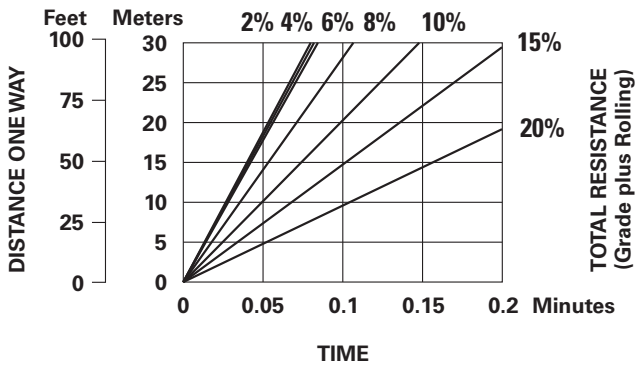
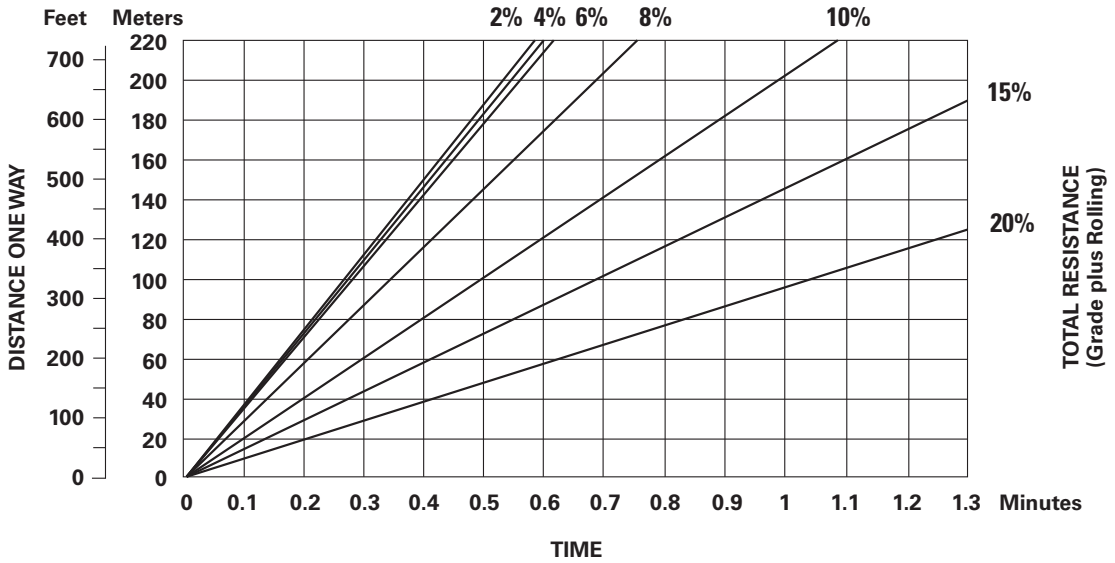

**NOTE:** Curves assume use of highest operating speed attainable: 3rd gear for 2%-8% TR, 2nd gear for 10%-20% TR.

In load-and-carry applications it is important to consult the tire manufacturer on Ton-MPH ratings and pressure recommendations.

- 990K
- 45/65R39 Tires

**990K TRAVEL TIME — EMPTY**

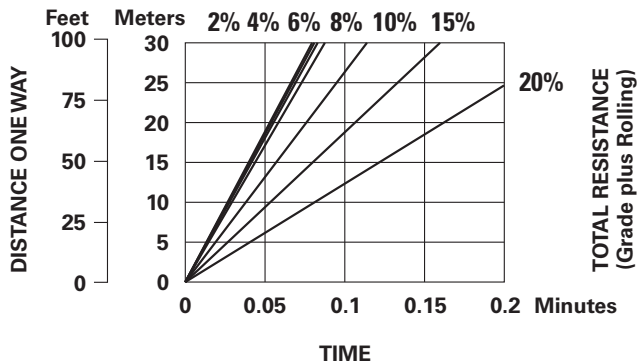
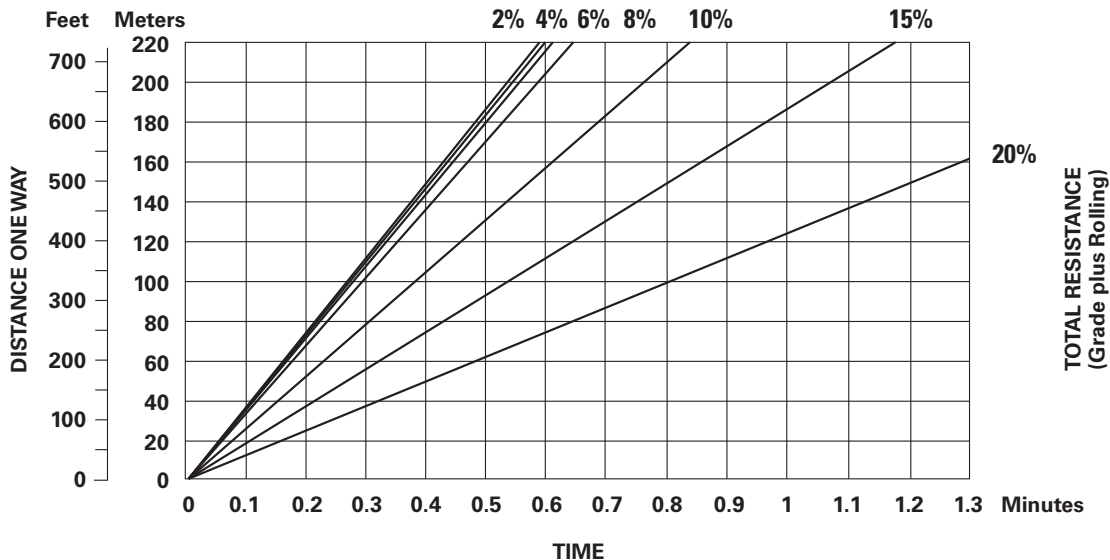

**NOTE:** Curves assume use of highest operating speed attainable: 3rd gear for 2%-10%TR, 2nd gear for 15% and 20%TR.

In load-and-carry applications it is important to consult the tire manufacturer on Ton-MPH ratings and pressure recommendations.

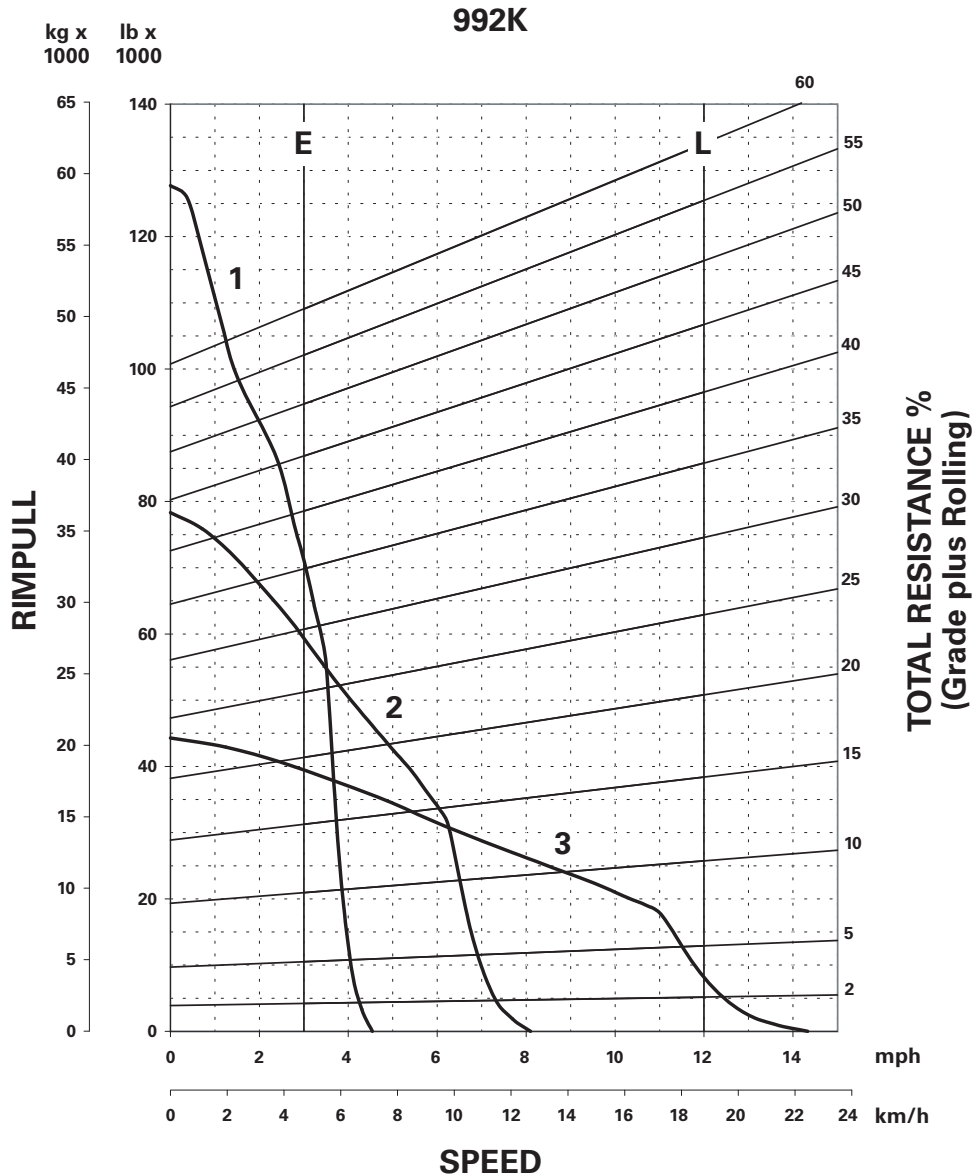

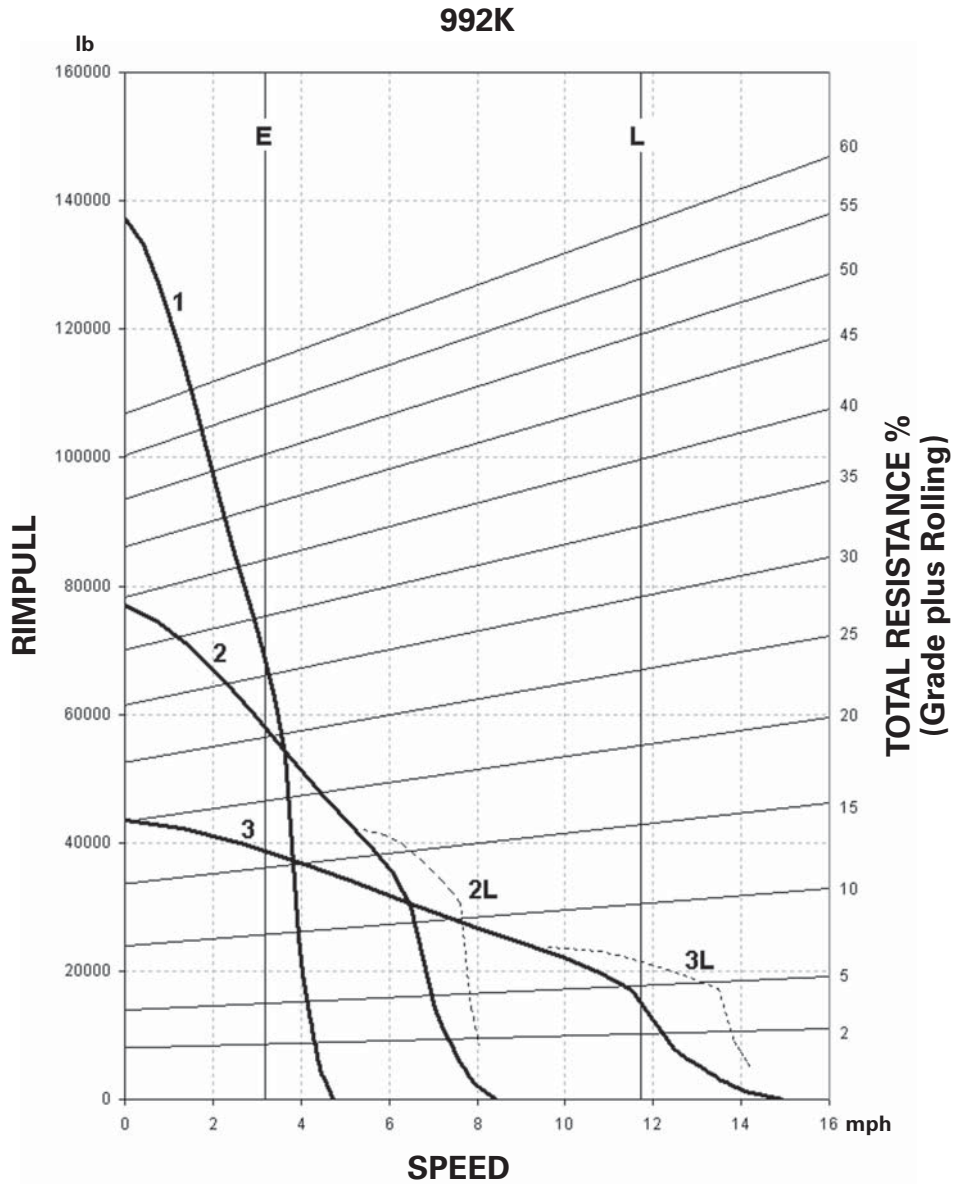

**992K TRAVEL TIME — LOADED**

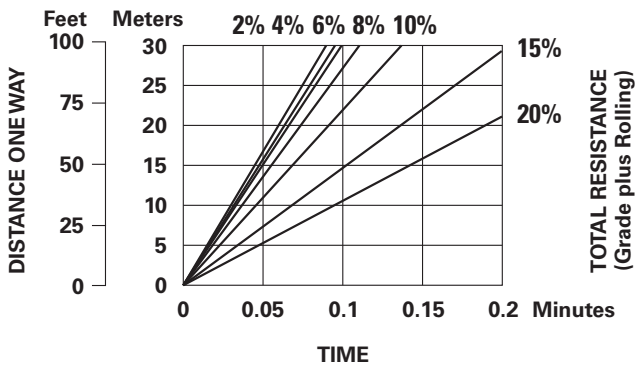
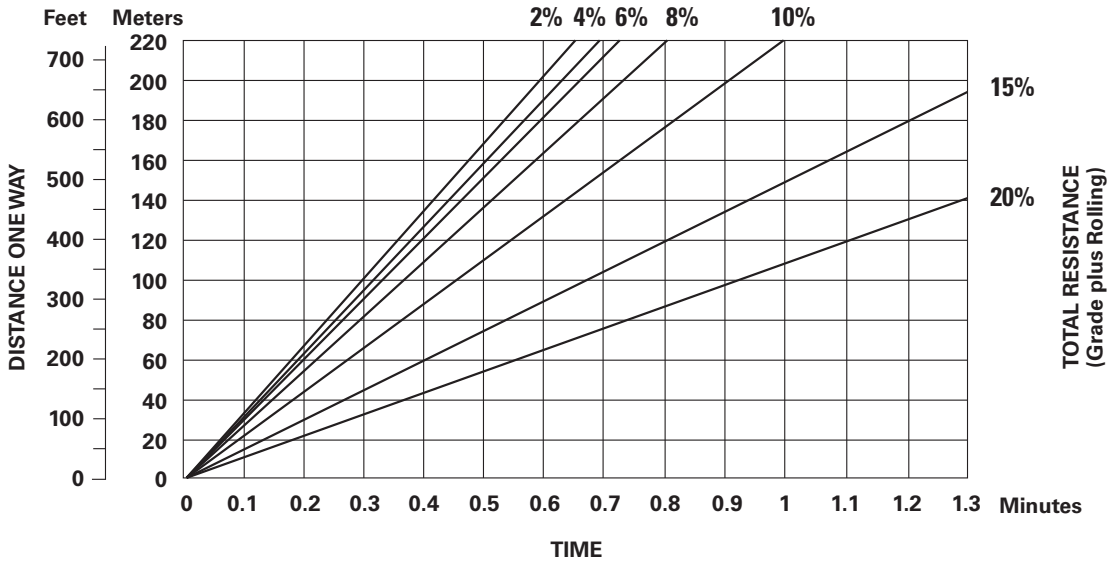

**NOTE:** Curves assume use of highest operating speed attainable: 3rd gear for 2%-10%TR, 2nd gear for 15% and 20% TR.

In load-and-carry applications it is important to consult the tire manufacturer on Ton-MPH ratings and pressure recommendations.



- 992K
- 45/65-45 Tires

**992K TRAVEL TIME — EMPTY**

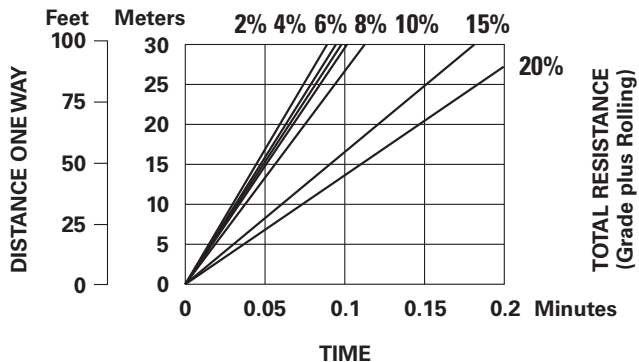
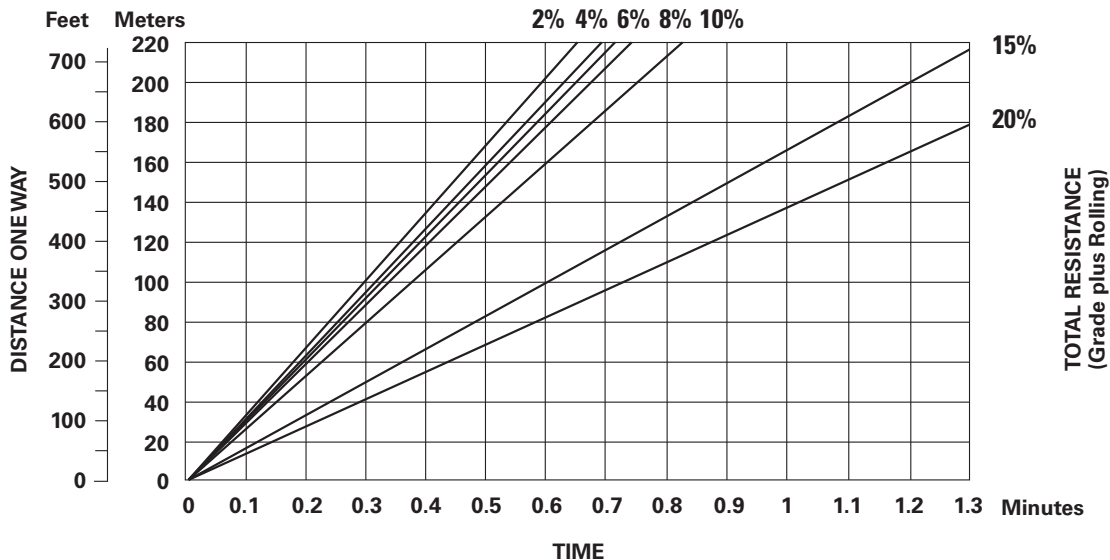

**NOTE:** Curves assume use of highest operating speed attainable: 3rd gear for 2%-10%TR, 2nd gear for 15% and 20% TR.

In load-and-carry applications it is important to consult the tire manufacturer on Ton-MPH ratings and pressure recommendations.

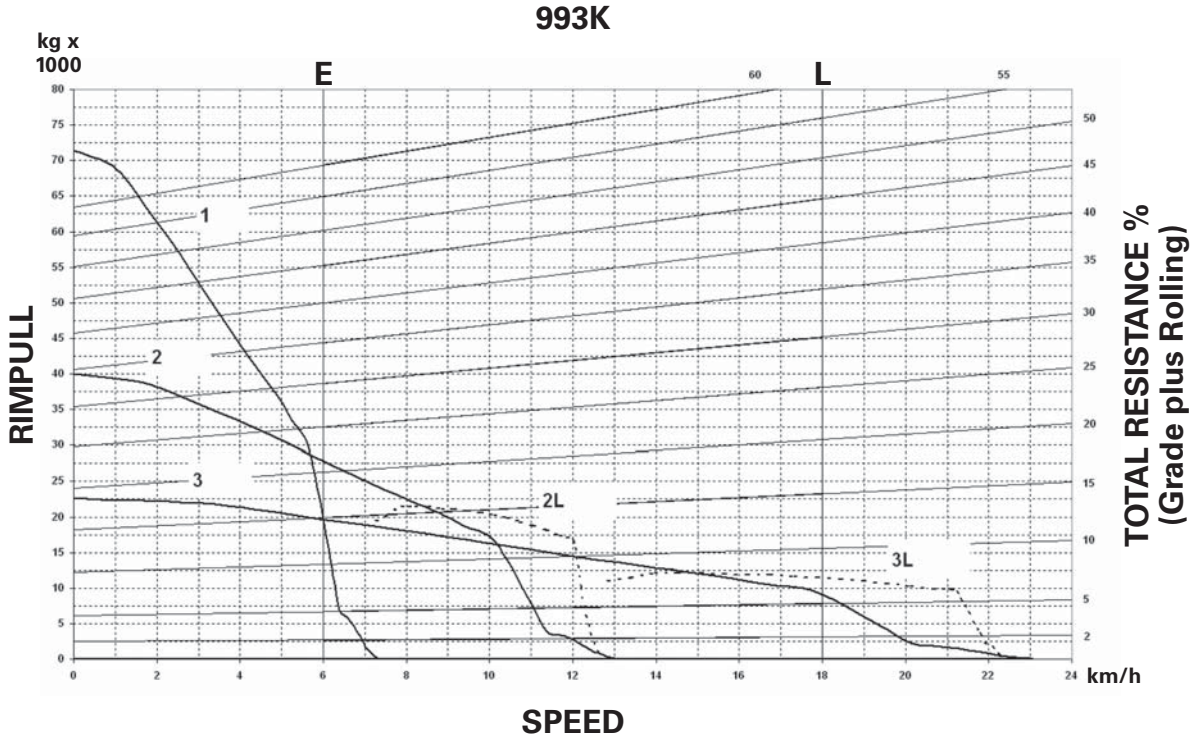

993K

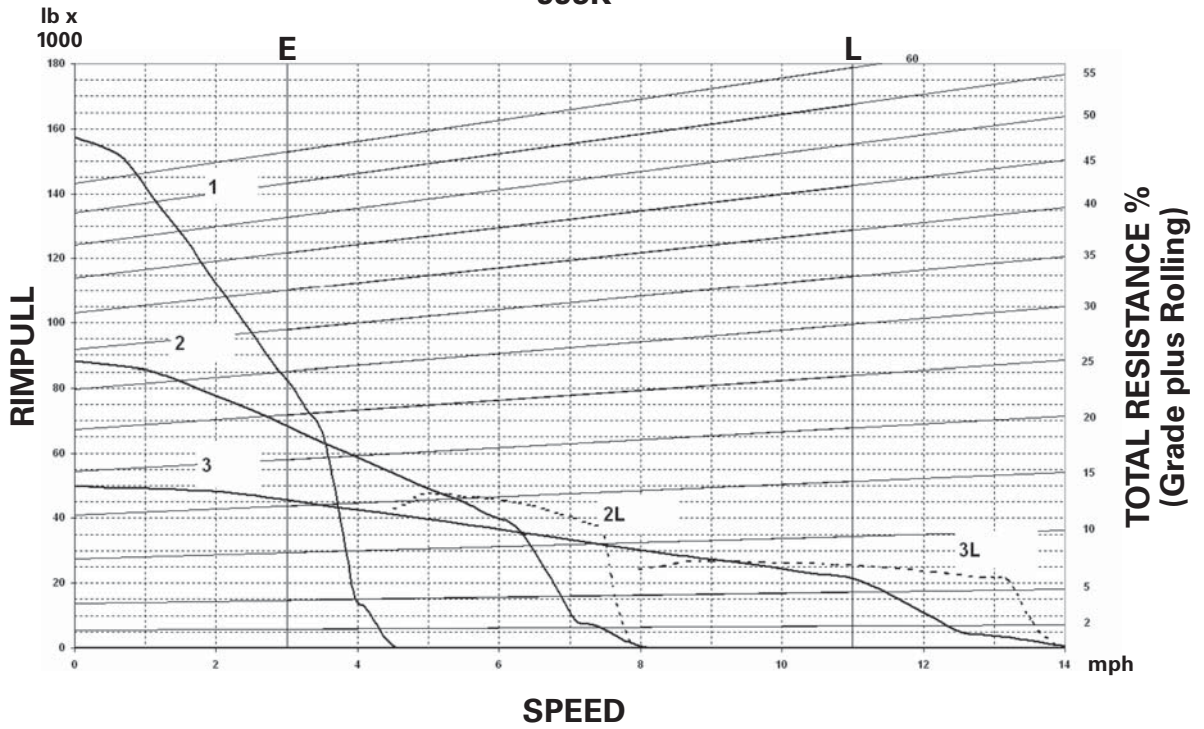

KEY

- 1 — 1st Gear
- 2 — 2nd Gear
- 3 — 3rd Gear

KEY

- E — Empty
- L — Loaded

Calculated Pull: Idle Hydraulics  
Curves Assume NO SLIP  
Conditions

- Travel Time — Loaded
- 993K — Lock-Up Clutch
- Idle Hydraulics

**Wheel Loaders  
Integrated Toolcarriers**

**993K TRAVEL TIME — LOADED**

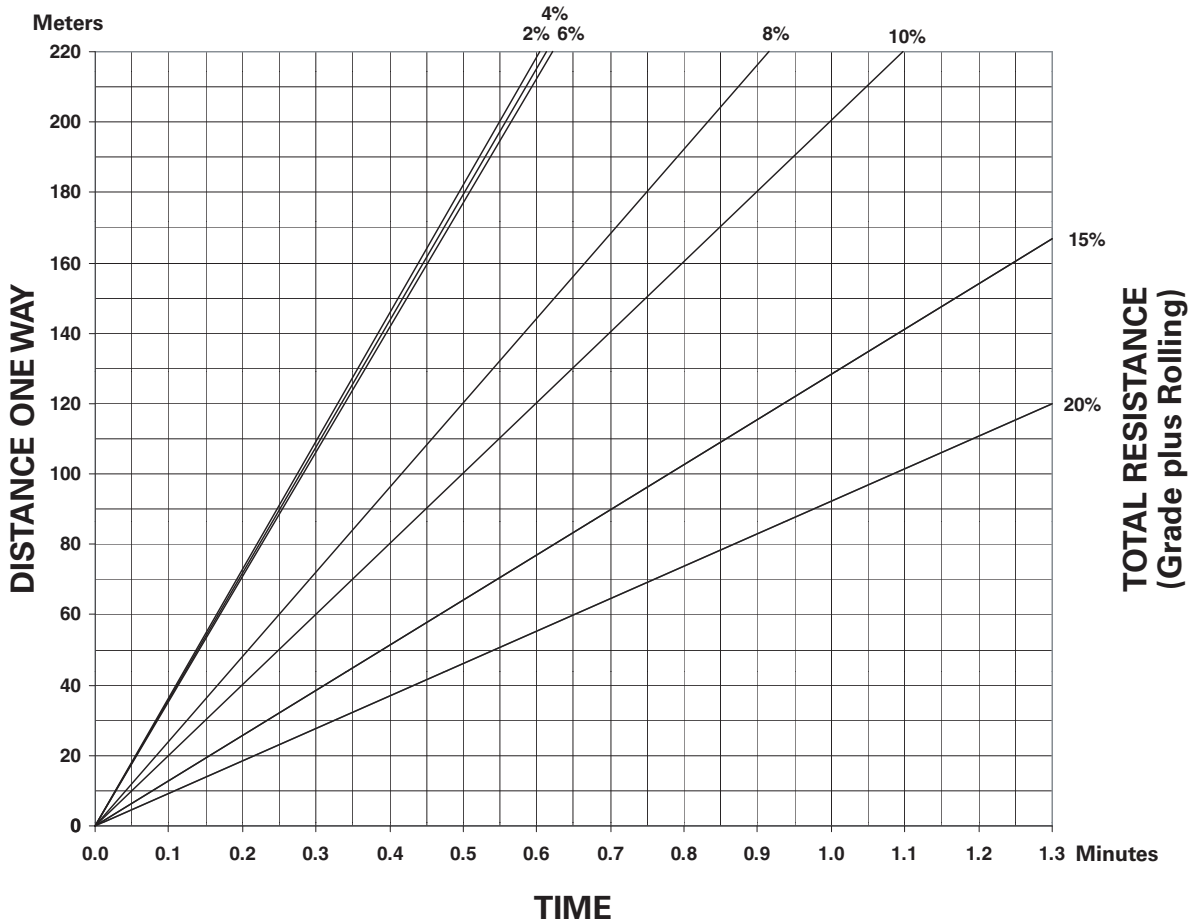

**Wheel Loaders  
Integrated Toolcarriers**

- Travel Time — Empty
- 993K — Lock-Up Clutch
  - Idle Hydraulics

**993K TRAVEL TIME — EMPTY**

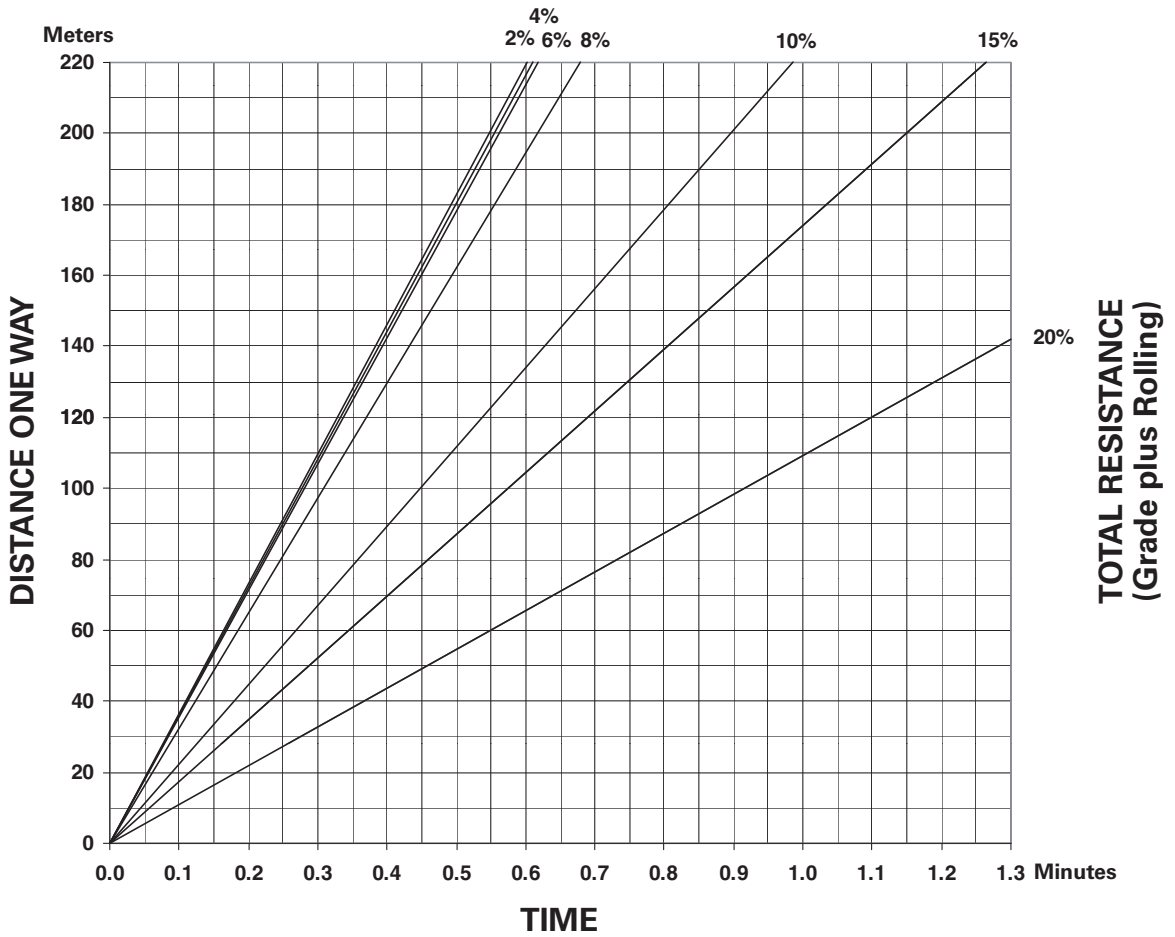

### 993K TRAVEL TIME — LOADED

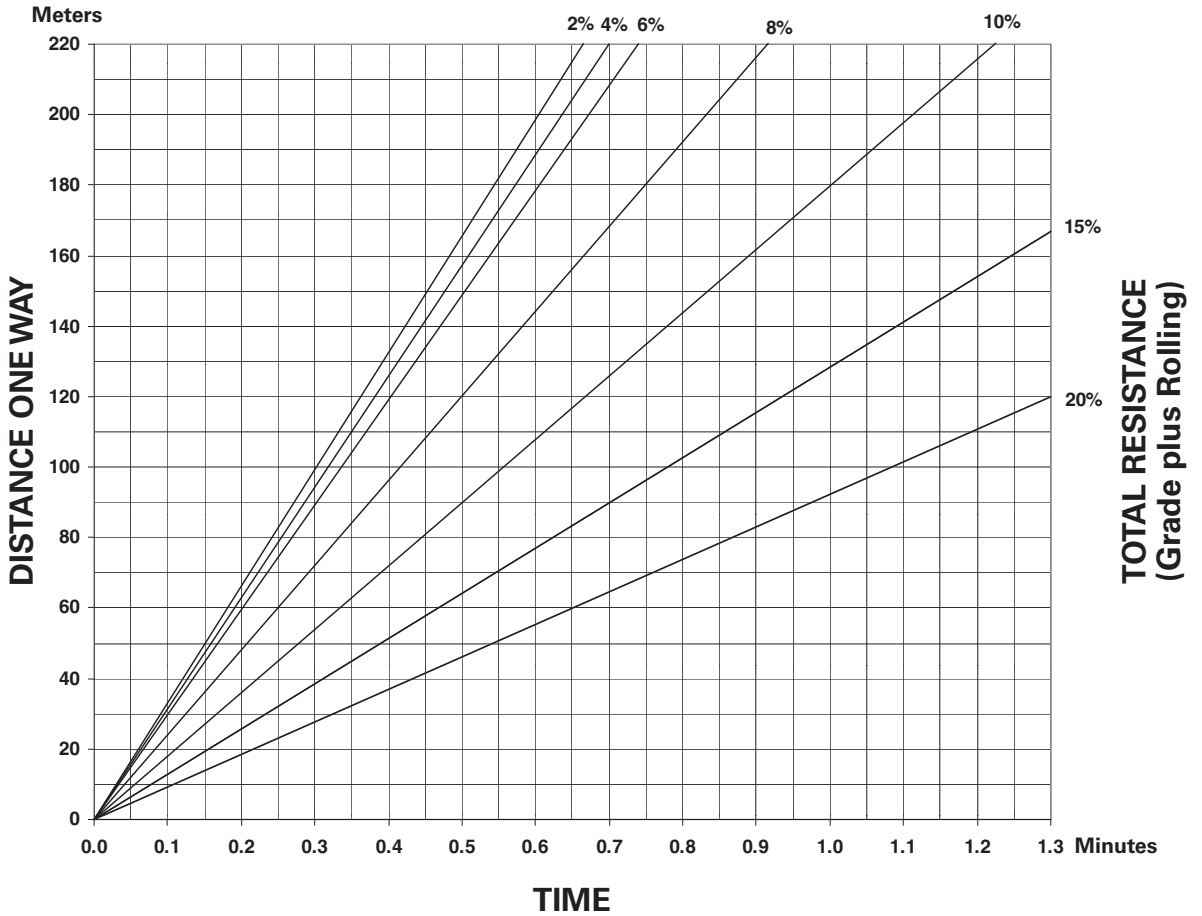

**Wheel Loaders  
Integrated Toolcarriers**

Travel Time — Empty

● 993K — Standard

● Idle Hydraulics

**993K TRAVEL TIME — EMPTY**

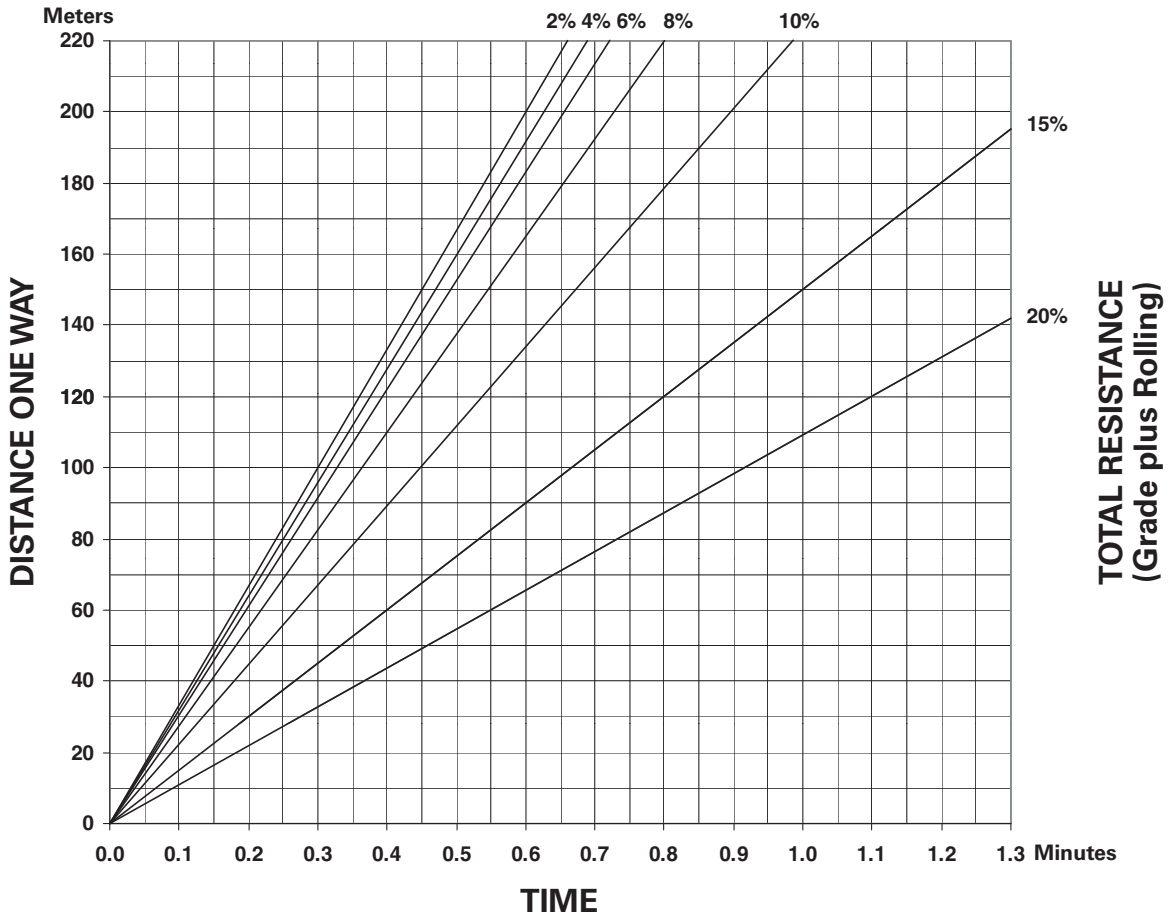

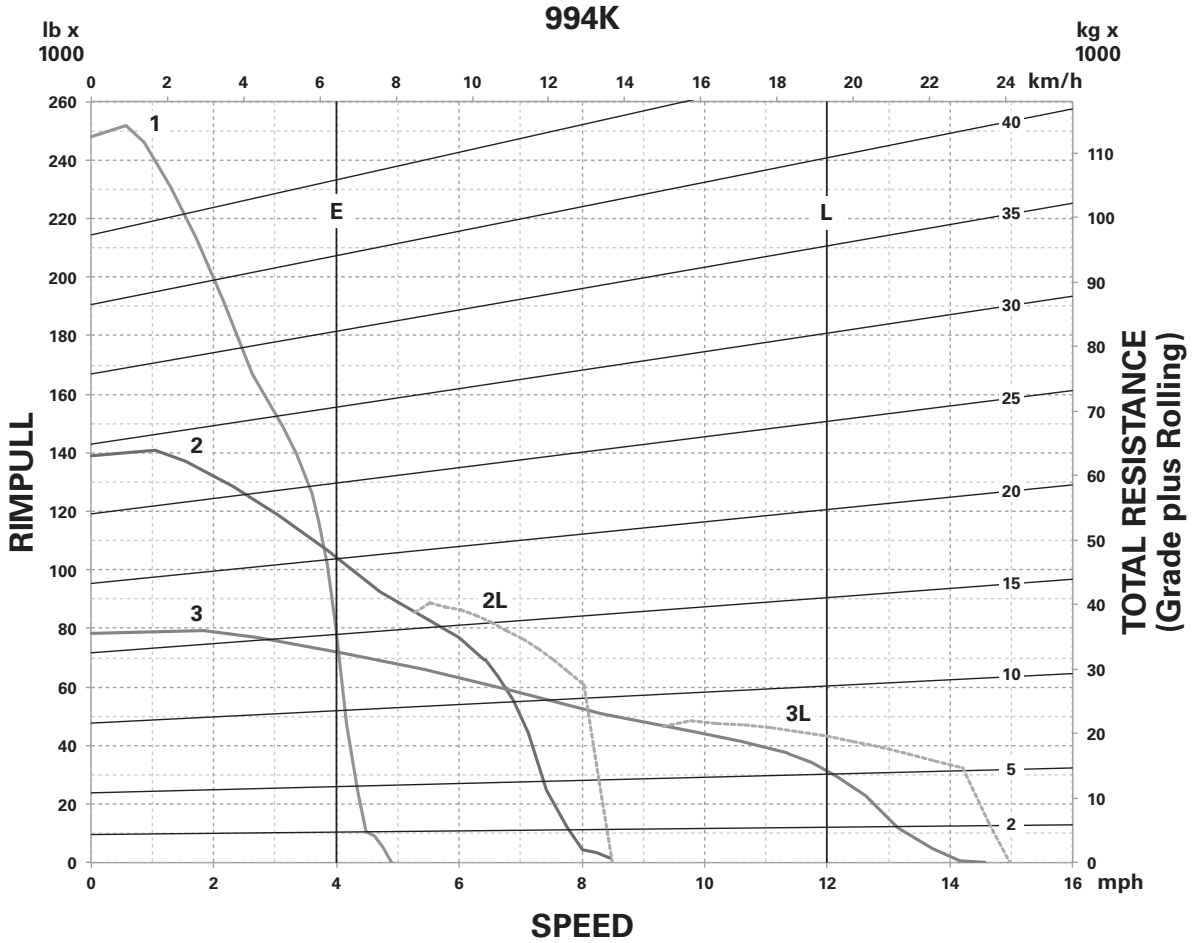

**KEY**  
 1 — 1st Gear  
 2 — 2nd Gear  
 3 — 3rd Gear

**KEY**  
 E — Empty 236 136 kg (519,500 lb)  
 L — Loaded 274 318 kg (603,500 lb)

Calculated Pull: Idle Hydraulics  
 Curves Assume NO SLIP Conditions



# Wheel Loaders Integrated Toolcarriers

## Travel Time — Loaded

- 994K Steady State
- 58/85-57 Tires

### 994K TRAVEL TIME — LOADED

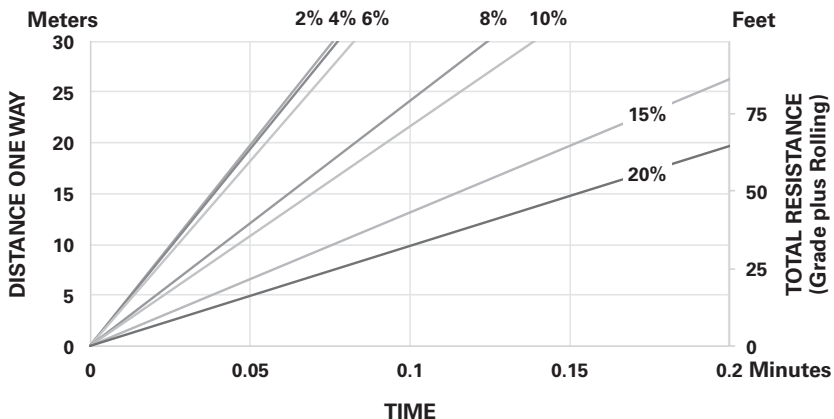
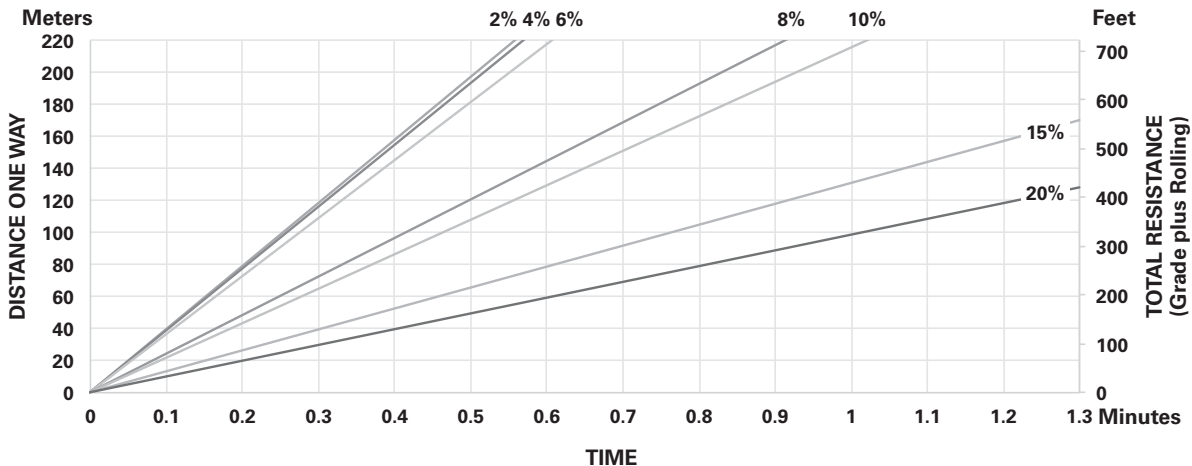

**NOTE:** Curves assume use of highest operating speed attainable: 3rd gear for 2%-8% TR, 2nd gear for 10% and 15% TR, 1st gear for 20% TR.

In load-and-carry applications it is important to consult the tire manufacturer on Ton-MPH ratings and pressure recommendations.

### 994K TRAVEL TIME — EMPTY

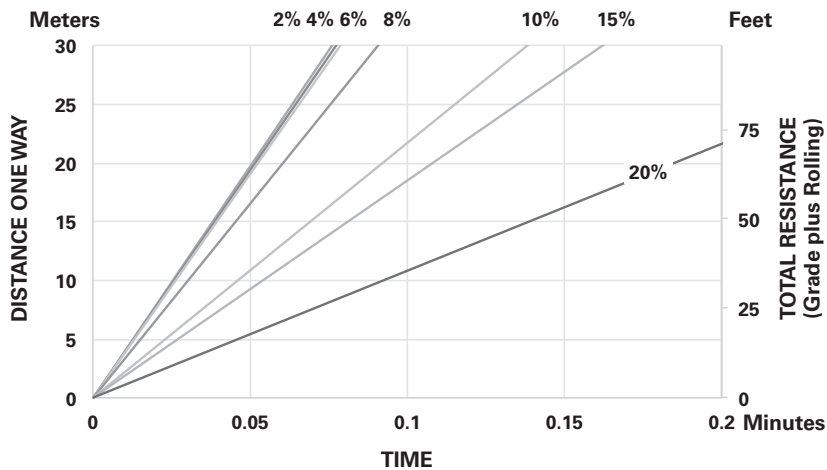
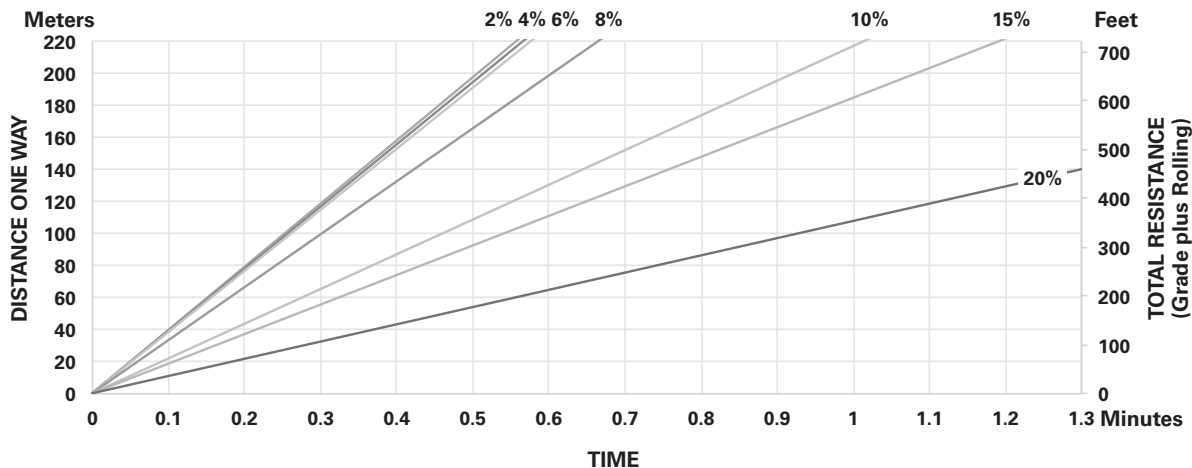

**NOTE:** Curves assume use of highest operating speed attainable: 3rd gear for 2%-10%TR, 2nd gear for 15% TR, 1st gear for 20% TR.

In load-and-carry applications it is important to consult the tire manufacturer on Ton-MPH ratings and pressure recommendations.

# Wheel Loaders Integrated Toolcarriers

## Production Estimating Table

● m<sup>3</sup> or yd<sup>3</sup>/60 min. hour

Bucket Size (m <sup>3</sup> or yd <sup>3</sup> )		1.0	1.5	2.0	2.5	3.0	3.5	4.0	4.5	5.0	5.5	6.0	6.5	7.0	7.5	8.0	8.5	9.0	9.5	10.0			
<b>Cycle Time</b>	<b>Cycles Per Hr</b>	Unshaded area indicates average production.																					
0.35	171																						
0.40	150	150	225	330	375	450	525																
0.45	133	135	200	268	332	400	466	530	600	665	730	800	865										
0.50	120	120	180	240	300	360	420	480	540	600	660	720	780	840	900	960	1003	1080	1140	1200			
0.55	109	109	164	218	272	328	382	436	490	545	600	655	705	765	820	870	925	980	1008	1090			
0.60	100	100	150	200	250	300	350	400	450	500	550	600	650	700	750	800	850	900	950	1000			
0.65	92	92	138	184	230	276	322	368	416	460	505	555	600	645	690	735	780	830	875	920			
0.70	86							342	386	430	474	515	560	600	645	690	730	775	815	860			
0.75	80													560	600	640	680	720	760	800			

Bucket Size (m <sup>3</sup> or yd <sup>3</sup> )		11.0	12.0	13.0	14.0	15.0	16.0	17.0	18.0	19.0	20.0	21.0	22.0	23.0	24.0	25.0	26.0
<b>Cycle Time</b>	<b>Cycles Per Hr</b>	Unshaded area indicates average production.															
0.35	171																
0.40	150																
0.45	133																
0.50	120	1320	1440														
0.55	109	1200	1310	1420	1520	1635	1740	1850	1960	2070	2180	2285	2395	2505	2615	2725	2830
0.60	100	1100	1200	1300	1400	1500	1600	1700	1800	1900	2000	2100	2200	2300	2400	2500	2600
0.65	92	1010	1105	1195	1285	1380	1470	1560	1655	1745	1840	1930	2020	2115	2205	2300	2390
0.70	86	945	1030	1120	1200	1290	1375	1460	1545	1630	1720	1805	1890	1975	2060	2150	2235
0.75	80	880	960	1040	1120	1200	1280	1360	1440	1520	1600	1680	1760	1840	1920	2000	2080
0.80	75			975	1050	1125	1200	1275	1350	1425	1500	1575	1650	1725	1800	1875	1950

### Job Efficiency Worktime/Hr

60 Min Hr

55

50

45

40

—

### Efficiency Factor

100%

91%

83%

75%

69%

—

### Bucket Load Factor

Bucket Size × 1.00

0.95

0.90

0.85

0.80

0.75

Production Estimating Table  
 ● 60 min hour ● Shot Rock  
 ● Metric Tons

Wheel Loaders  
 Integrated Toolcarriers

**Metric Tons ● 1600 kg Lm<sup>3</sup> (1.6 t) density**

Bucket Size m <sup>3</sup>		1.0	1.5	2.0	2.5	3.0	3.5	4.0	4.5	5.0	5.5	6.0	6.5	7.0	7.5	8.0	8.5	9.0	9.5
Cycle Time	Cycles Per Hr	Unshaded area indicates average production.																	
0.40	150	240	360	480	600	720													
0.45	133	213	319	426	532	638	745	851	958	1064	1170								
0.50	120	192	288	384	480	576	672	768	864	960	1056	1152	1248	1344	1440	1536	1632	1730	1825
0.55	109	174	262	349	436	523	610	698	785	872	959	1046	1134	1221	1308	1395	1482	1570	1655
0.60	100	160	240	320	400	480	560	640	720	800	880	960	1040	1120	1200	1280	1360	1440	1520
0.65	92	147	221	294	368	442	515	589	662	736	810	883	957	1030	1104	1178	1251	1325	1400
0.70	86						482	550	619	688	757	826	894	963	1032	1101	1170	1238	1310
0.75	80											768	832	896	960	1024	1088	1150	1215
Bucket Payload Metric (Tons)		1.6	2.4	3.2	4.0	4.8	5.6	6.4	7.2	8.0	8.8	9.6	10.4	11.2	12.0	12.8	13.6	14.4	15.2

Bucket Size m <sup>3</sup>		10.0	11.0	12.0	13.0	14.0	15.0	16.0	17.0	18.0	19.0	20.0
Cycle Time	Cycles Per Hr	Unshaded area indicates average production.										
0.40	150											
0.45	133											
0.50	120											
0.55	109	1744	1918	2092	2267	2441	2616	2790	2964	3139	3313	3488
0.60	100	1600	1760	1920	2080	2240	2400	2560	2720	2880	3040	3200
0.65	92	1472	1619	1766	1913	2060	2208	2355	2502	2649	2796	2944
0.70	86	1376	1513	1651	1788	1926	2064	2201	2339	2476	2614	2752
0.75	80	1280	1408	1536	1664	1792	1920	2048	2176	2304	2432	2560
0.80	75	1200	1320	1440	1560	1680	1800	1920	2040	2160	2280	2400
Bucket Payload Metric (Tons)		16.0	17.6	19.2	20.8	22.4	24.0	25.6	27.2	28.8	30.4	32.0

# Wheel Loaders Integrated Toolcarriers

## Production Estimating Table

- Shot Rock ● 60 min hour
- U.S. Tons

### U.S. Tons ● 2700 lb/LCY (1.35 T) density

Bucket Size yd <sup>3</sup>	1.0	1.5	2.0	2.5	3.0	3.5	4.0	4.5	5.0	5.5	6.0	6.5	7.0	7.5	8.0	8.5	9.0	9.5	10.0	
<b>Cycle Time</b>	<b>Cycles Per Hr</b>	Unshaded area indicates average production.																		
0.40	150	203	330	420	510	615	705	810												
0.45	133	180	293	360	454	545	625	720	810	905	985	1080	1170							
0.50	120	162	254	324	408	492	565	650	730	815	890	970	1060	1140	1200	1300	1380	1470	1540	1620
0.55	109	147	240	294	370	448	515	590	665	740	805	885	960	1030	1090	1180	1250	1330	1400	1740
0.60	100	135	220	270	340	410	470	540	610	680	740	810	880	950	1000	1080	1150	1220	1280	1350
0.65	92	124	200	250	314	380	435	500	560	625	680	750	810	875	920	985	1060	1120	1180	1250
0.70	86								525	585	635	695	755	815	860	930	990	1050	1100	1160
0.75	80													760	800	865	920	975	1030	1080
<b>Bucket Payload (Tons)</b>	<b>1.35</b>	<b>2.2</b>	<b>2.7</b>	<b>3.4</b>	<b>4.1</b>	<b>4.7</b>	<b>5.4</b>	<b>6.1</b>	<b>6.8</b>	<b>7.4</b>	<b>8.1</b>	<b>8.8</b>	<b>9.5</b>	<b>10.0</b>	<b>10.8</b>	<b>11.5</b>	<b>12.2</b>	<b>12.8</b>	<b>13.5</b>	

Bucket Size yd <sup>3</sup>	11.0	12.0	13.0	14.0	15.0	16.0	17.0	18.0	19.0	20.0	21.0	22.0	23.0	24.0	25.0	26.0	
<b>Cycle Time</b>	<b>Cycles Per Hr</b>	Unshaded area indicates average production.															
0.40	150																
0.45	133																
0.50	120	1782	1945														
0.55	109	1620	1765	1905	2060	2200	2350	2495	2645	2790	2940	3080	3235	3375	3530	3670	3825
0.60	100	1485	1620	1750	1890	2020	2160	2290	2430	2560	2700	2830	2970	3100	3240	3370	3510
0.65	92	1365	1490	1610	1735	1855	1985	2105	2235	2355	2480	2600	2730	2850	2980	3100	3225
0.70	86	1275	1390	1505	1625	1735	1855	1965	2085	2200	2320	2430	2550	2665	2785	2895	3015
0.75	80	1190	1295	1400	1510	1615	1725	1830	1940	2045	2160	2260	2375	2480	2590	2695	2805
0.80	75			1310	1415	1515	1620	1715	1820	1920	2025	2120	2225	2325	2430	2525	2630
<b>Bucket Payload (Tons)</b>	<b>14.9</b>	<b>16.4</b>	<b>17.5</b>	<b>18.9</b>	<b>20.2</b>	<b>21.6</b>	<b>22.9</b>	<b>24.3</b>	<b>25.6</b>	<b>27.0</b>	<b>28.3</b>	<b>29.7</b>	<b>31.0</b>	<b>32.4</b>	<b>33.7</b>	<b>35.1</b>	

**Attachments**

	903C2	906K/M, 907K/M, 908K/M	910K/M	914K/M	918M	924K, 926M	930K, 930M	938K, 938M	950K, 962K	950H, 962H	966H, 966K, 966M, 972H, 972K, 972M	980K, 980H	986H	988K	990K	992K	993K	994K	
Fusion Quick Coupler						X	X	X	X	X	X								
Quick Coupler	X	X	X	X	X							X							
Performance Series General Purpose Bucket			X	X	X	X	X	X	X	X	X	X	X	X					
General Purpose Bucket	X	X								X	X	X							
Performance Series Material Handling Bucket									X	X	X	X							
Material Handling Bucket			X	X	X					X	X	X							
Sand & Gravel Bucket						X	X	X											
Performance Series Coal Bucket										X	X	X							
Coal Bucket			X	X	X					X	X	X				X	X	X	X
Performance Series Rock Bucket									X	X	X	X	X	X					
Rock Bucket										X	X	X				X	X	X	X
Performance Series Heavy Duty Rock Bucket												X	X	X	X				
Heavy Duty Rock Bucket												X			X	X			
Performance Series Heavy Duty Granite Bucket													X	X	X				
Heavy Duty Granite Bucket															X	X	X		
Heavy Abrasion Rock Bucket																X	X		
Iron Ore Bucket															X	X	X		
Serrated Edge Rock Bucket															X	X	X		
Multi-purpose Bucket	X	X							X	X	X								
Side Dump Bucket			X	X	X	X	X	X	X	X	X								
High Dump Bucket						X	X	X	X	X	X								
Grapple Bucket		X				X	X	X	X	X	X								
Waste Handling Bucket						X	X	X	X	X	X	X							
Woodchip Bucket			X	X	X	X	X	X	X	X	X	X							
Slag Bucket											X	X			X				
Fertilizer Bucket			X	X	X														
Grading Bucket						X	X	X											
Light Material Bucket	X	X	X	X	X	X	X	X											

NOTE: List is not all-inclusive. Contact your Cat dealer for special attachment needs.

<b>Attachments</b>	903C2	906K/M, 907K/M, 908K/M	910K/M	914K/M	918M	924K, 926M	930K, 930M	938K, 938M	950K, 962K	950H, 962H	966H, 966K, 966M, 972H, 972K, 972M	980K, 980H	986H	988K	990K	992K	993K	994K	
Pallet Fork	X	X	X	X	X	X	X	X	X	X	X	X							
Construction Fork						X	X	X											
Log & Lumber Fork			X	X	X	X	X	X	X	X	X								
Logging Fork									X	X	X	X							
Millyard Fork								X	X	X	X	X		X	X				
Unloading Grapple Fork								X	X										
Pipe & Pole Fork							X	X	X	X	X								
Grapple Forks						X	X	X											
Asphalt Cutters						X	X												
Auger		X																	
Blade			X	X	X						X								
Angle Broom		X	X	X	X	X	X	X	X	X									
Special Application Broom		X	X	X	X	X	X	X	X	X									
Pickup Broom		X	X	X	X	X	X	X											
Cold Planer		X																	
Compactors		X																	
Landscape Tillers		X																	
Material Handling Arm		X	X	X	X	X	X	X	X	X	X	X							
Rake		X				X	X	X	X	X	X								
Reversible Plow			X	X	X	X	X	X	X	X	X	X							
V-plow			X	X	X		X	X	X	X	X								
Snow Blower		X																	
Snow Push		X	X	X	X	X	X	X											
Stump Grinder		X																	
Trencher		X																	
Wheel Saw		X																	
Block Handling Tools												X	X	X					

**NOTE:** List is not all-inclusive. Contact your Cat dealer for special attachment needs.

## BUCKETS

**Performance Series** — optimized fill factors for use in truck loading, stockpiling and load-and-carry applications.

**General Purpose** — provide good all-around performance for stockpiling, re-handling, excavating and bank loading.

**Material Handling** — designed for efficient loading of stockpiled materials.

**Coal** — high-volume material movers, for loading and stockpiling coal and other materials of similar density.

**Rock** — designed for high production in abrasive applications.

**Multi-Purpose** — versatile ... loads, strips topsoil, bulldozes, clamps pipe, and cleans up debris, plus many other tasks.

**Side Dump** — dump forward or to the left ... ideal in tight quarters or to reduce turning time.

**High Dump** — for extended dump height of light materials.

**Grapple** — equipped with dual top clamps to grab and hold loose material.

**Waste Handling** — move large volumes for low-density refuse in transfer stations, landfills and recycling yards.

**Woodchip** — optimized for moving large volumes of wood chips.

**Slag** — heavy duty and specifically constructed to handle extreme conditions that come with handling hot slag.

## FORKS

**Pallet** — for a variety of task, tines are adjustable and available in several different lengths.

**Log & Lumber** — flat tines and raised back are designed specifically for use in handling both unfinished logs and stack lumber. Available with top clamp.

**Logging** — equipped with two independent top clamps, for use loading and unloading trucks and feeding the mill.

**Millyard** — equipped with one-piece top clamp, built for moving, sorting and feeding the mill.

**Unloading Grapple** — short tines and large top clamp opening ideal for unloading logs from trucks.

**Pipe & Pole** — wide carriage, fixed tines and full width double-acting clamp are ideal for transporting, loading and unloading pipe.

## AND MORE ...

**Brooms** — for street or job site cleanup, snow removal etc. Angle, Special Application and Pick-up models available.

**Material Handling Arms** — provides a tool that can pick, carry and load a variety of materials. Arm length can be adjusted.

**Plows** — ideal for snow clearing, available in angling and V-plow styles.

**Rakes** — versatile tools that work well in light-duty, medium-duty and heavy-duty land clearing situations. Available with top clamp.

## Integrated Toolcarriers Attachments

Attachments	910K/M	914K/M	918M
Performance Series			
General Purpose Bucket	X	X	X
General Purpose Bucket	X	X	X
Material Handling Bucket	X	X	X
Coal Bucket			
Multi-Purpose Bucket	X	X	X
Side Dump Bucket	X	X	X
High Dump Bucket			
Grapple Bucket			
Waste Handling Bucket			
Woodchip Bucket			
Pallet Fork	X	X	X
Log & Lumber Fork			
Logging Fork			
Millyard Fork			
Grapple Fork	X	X	X
Asphalt Cutter			
Straight Blade			
Angle Blade	X	X	X
Angle Broom	X	X	X
Special Application Broom			
Pick-up Broom			
Material Handling Arm	X	X	X
Reversible Plow			
V-plow			
One Way Plow			
Rake			

This list not all inclusive. Contact your Cat dealer for special attachment needs.



## **FUSION COUPLER SYSTEM**

Caterpillar is breaking new ground with the Fusion Coupler System. Caterpillar engineers designed this new system to exceed the performance of any other Cat or competitive coupler solution in the marketplace. This coupler system is a factory- or field-installed option for Cat Loaders from 924K through 972, including IT38 and IT62 machines. Fusion offers benefits in four main categories:

### **Performance**

This new, patented interface provides coupler flexibility with performance virtually identical to pin-on.

Imagine lifting a hundred-pound box with your arms fully extended. Now, imagine lifting that same load close to your body. That's the genius of Fusion: designed to integrate the attachment and the machine by pulling the coupler and tool closer to the wheel loader. As a result, the center of gravity is moved inward, towards the machine. This translates to increased lifting ability when compared to machines equipped with competing coupler systems.

### **Durability**

The advanced wedging mechanism of the Fusion Coupler creates a tight, rattle-free fit. This new lock up system eliminates play and wear — resulting in a long service life.

Wedges pull the attachment tight to the machine in two directions — in and down. Constant hydraulic pressure on the coupler wedges compensate for wear, assuring a tight fit throughout the life of the coupler. Tight fit gives better tool control and increased productivity. Plus, coupler durability is substantially increased over traditional couplers.

### **Visibility**

A new, open coupler frame design opens sight lines from the operator's seat, making it easier than ever before to engage and disengage attachments with certainty.

Offset tines and other design changes to Fusion Pallet Forks, working in conjunction with the Fusion Coupler, increase visibility substantially at ground level and truck bed height when compared to traditional coupler and fork combinations.

### **Flexibility/Compatibility**

With the Fusion Coupler system, Caterpillar customers get **one common interface**. This unique, single interface eliminates the need for many different couplers across the entire range of Cat Small and Medium Wheel Loaders. This expanded machine compatibility not only allows one machine to pick up a range of attachments, but also for one attachment to be used by a host of different machines. Realize the flexibility and opportunity afforded your rental operation, or the improvements to machine and attachment management on your customers' job sites.

Fusion is supported by a full line of attachments. Just about any attachment available for pin-on is also available, or can be converted, to work with Fusion. For complete information on Fusion attachments available for Cat Loaders 924 through 972, consult Fusion Product Bulletin GEJQ0222.

<b>Fusion Attachments</b>	924K, 926M	930K, 930M	938K, 938M	950K, 962K	950H, 962H	IT62H/G	966K/H	972K/H
Performance Series General Purpose Bucket	X	X	X	X	X		X	X
General Purpose Bucket				X	X	X	X	X
Performance Series Material Handling Bucket	X	X	X	X			X	X
Material Handling Bucket				X	X	X	X	X
Performance Series Coal Bucket							X	X
Coal/Light Material Bucket					X	X	X	X
Performance Series Rock Bucket				X			X	X
Rock Bucket				X	X		X	X
Multi-purpose Bucket				X	X	X	X	X
Sand & Gravel Bucket	X	X	X	X	X	X	X	X
Side Dump Bucket	X	X	X	X	X	X	X	X
High Dump Bucket	X	X	X	X	X	X	X	X
Grapple Bucket	X	X	X	X	X	X	X	X
Waste Handling Bucket	X	X	X	X	X	X	X	X
Woodchip Bucket	X	X	X	X	X	X	X	X
Light Material Bucket	X	X	X					
Pallet Fork	X	X	X	X	X	X	X	X
Construction Fork	X	X	X					
Log & Lumber Fork	X	X	X	X	X	X	X	X
Logging Fork				X				
Millyard Fork	X	X	X	X				
Grapple Fork				X				
Pipe & Pole Fork	X	X	X	X	X		X	X
Sorting Grapple	X	X	X					
Angle Broom	X	X	X	X	X			
Special Application Broom	X	X	X	X	X			
Pickup Broom	X	X	X					
Material Handling Arm	X	X	X	X	X	X	X	X
Rake	X	X	X	X	X	X	X	X
Reversible Plow	X	X	X	X	X	X	X	X
V-plow				X	X		X	X

**NOTE:** This list is not all-inclusive. Contact your Cat dealer for special attachment needs.



# WHEEL TRACTOR-SCRAPERS

## CONTENTS

### WHEEL TRACTOR-SCRAPERS

#### Specifications:

Elevating Bowl . . . . .	24-2
Single Engine Open Bowl . . . . .	24-3
Optional Push-Pull . . . . .	24-3
Twin Engine Open Bowl . . . . .	24-4
Optional Push-Pull . . . . .	24-4
Coal Bowl . . . . .	24-6
Ground Engaging Tools:	
Router Bits . . . . .	24-7
Cutting Edges . . . . .	24-7
Bowl Side Protectors . . . . .	24-9
Elevating Scraper . . . . .	24-9
K Series Features and Benefits . . . . .	24-10
Material Application Guide . . . . .	24-12
Push-Load TTT Match . . . . .	24-12

Tire Options, All Models . . . . .	24-13
Cushion Hitch . . . . .	24-14
Wheel Tractor-Scraper Anatomy . . . . .	24-14
Use of Rimpull-Speed-Gradeability Curves . . . . .	24-15
Fixed Times for Scrapers . . . . .	24-17
Use of Retarder Curves . . . . .	24-17
Curves/Charts:	
621K Rimpull, Retarding . . . . .	24-19
623K Rimpull, Retarding . . . . .	24-21
627K Rimpull, Retarding . . . . .	24-23
631K Rimpull, Retarding . . . . .	24-25
637K Rimpull, Retarding . . . . .	24-27
657G Rimpull, Retarding . . . . .	24-29

MODEL	623K	
Flywheel Power	304 kW	407 hp
Approx. Operating Weight (Empty)◀	39 866 kg	87,809 lb
Scraper Capacity: Struck	14.4 m <sup>3</sup>	18.8 yd <sup>3</sup>
Heaped	17.6 m <sup>3</sup>	23 yd <sup>3</sup>
Rated Load	25 038 kg	55,200 lb
Weight Distribution — Empty:		
Drive	63%	
Rear	37%	
Weight Distribution — Loaded:		
Drive	52%	
Rear	48%	
Engine Model	C13 ACERT™	
Emission Standards	Tier 4 Final/Stage IV/Japan 2014 (Tier 4 Final)	
Rated Engine RPM	2000	
Displacement	12.5 L	763 in <sup>3</sup>
Top Speed (Loaded)	53.9 km/h	33.5 mph
180° Curb-to-Curb Turning Width	19.01 m	62'4"
Tires — Standard:		
Tractor/Scraper	33.25R29★E3	
Width of Cut	3.14 m	10'4"
Maximum Depth of Cut	262 mm	10.3"
Elevator Flight Spacing	520 mm	20"
Number of Flights	15	
Maximum Floor Opening	1.34 m	4'4"
Maximum Depth of Spread	465 mm	18'3"
Fuel Tank Refill Capacity	763 L	201 U.S. gal
Tractor DEF Tank	31.5 L	8.3 U.S. gal
GENERAL DIMENSIONS:		
Height — Overall Shipping	3.77 m	12'3"
Wheelbase	8.37 m	27'5"
Overall Length	13.77 m	45'2"
Overall Width	3.57 m	11'7"
Center Line of Scraper Tread	2.29 m	7'5"
Center Line of Tractor Tread	2.28 m	7'4"

◀ Operating weight includes coolants, lubricants, full fuel tank and operator. Operating weights for the 623K are based on U.S. EPA Tier 4 Final/EU Stage IV/ Japan 2014 (Tier 4 Final) platform machines. Deduct 243 kg (536 lb) for the operating weight for the 623K Tier 2/Stage II/Japan 2001 (Tier 2) equivalent.

**NOTE:** Wheel Tractor-Scrapers are not emission certified in Japan market.

### Elevating

The Elevating Wheel Tractor-Scraper is a self-loading hauling system with the added ability to mix/homogenize material and do precise finishing work.

#### Elevating Bowl Advantages:

- Load/haul/spread with little support equipment
- Conditions material as it loads
- Capable to work as a single machine
- Aids in compaction
- Finishing work
- Low rolling resistance applications
- Short cut areas
- Favorable material types
- Windrow applications
- Thin, precise lifts

#### Single Engine Advantages

##### (Compared to Tandem Engine):

- Lower fuel usage
- Lower gross vehicle weight

Specifications  
 ● Single Engine Open Bowl  
 ● Optional Push-Pull

Wheel Tractor-Scrapers

MODEL	621K		631K	
Flywheel Power	304 kW	407 hp	425 kW	570 hp
Approx. Operating Weight (Empty)◀	35 808 kg	78,943 lb	46 600 kg	102,750 lb
Scraper Capacity: Struck	13 m <sup>3</sup>	17.1 yd <sup>3</sup>	18.3 m <sup>3</sup>	24 yd <sup>3</sup>
Heaped	18.4 m <sup>3</sup>	24 yd <sup>3</sup>	26 m <sup>3</sup>	34 yd <sup>3</sup>
Rated Load	26 127 kg	57,610 lb	37 285 kg	82,200 lb
Weight Distribution — Empty:				
Drive		65%		67%
Rear		35%		34%
Weight Distribution — Loaded:				
Drive		53%		54%
Rear		47%		46%
Engine Model	C13 ACERT		C18 ACERT	
Emission Standards	Tier 4 Final/Stage IV/ Japan 2014 (Tier 4 Final)		Tier 4 Final/Stage IV/ Japan 2014 (Tier 4 Final)	
Rated Engine RPM	2000		1900	
Displacement	12.5 L	763 in <sup>3</sup>	18.1 L	1105 in <sup>3</sup>
Top Speed (Loaded)	53.9 km/h	33.5 mph	55.8 km/h	34.7 mph
180° Curb-to-Curb Turning Width	18.25 m	59'11"	19.94 m	65'5"
Tires — Tractor/Scraper	33.25R29**E3		37.25R35**E3	
Width of Cut	3.14 m	10'4"	3.51 m	11'6"
Maximum Depth of Cut	315 mm	12.4"	475 mm	18.7"
Maximum Depth of Spread	540 mm	21.3"	451 mm	17.8"
Fuel Tank Refill Capacity	763 L	201 U.S. gal	874 L	231 U.S. gal
Tractor DEF Tank	31.5 L	8.3 U.S. gal	31.5 L	8.3 U.S. gal
GENERAL DIMENSIONS: Non Push-Pull				
Height — Overall Shipping	4.03 m	13'2"	3.89 m	12'9"
Wheelbase	7.99 m	26'2"	8.81 m	28'11"
Overall Length	14.02 m	45'10"	15.04 m	49'4"
Overall Width	3.57 m	11'7"	3.94 m	12'11"
Center Line of Scraper Tread	2.29 m	7'5"	2.46 m	8'1"
Center Line of Tractor Tread	2.28 m	7'4"	2.46 m	8'1"
GENERAL DIMENSIONS: Push-Pull				
Operating Weight (Empty)	37 154 kg	81,910 lb	48 275 kg	106,430 lb
Overall Length (With Bail Down)	15.58 m	51'1"	16.64 m	54'7"
Weight Distribution — Empty:				
Drive		65%		68%
Rear		35%		32%
Weight Distribution — Loaded:				
Drive		53%		55%
Rear		47%		45%

◀ Operating weight includes standard machine, coolant, lubricants, full fuel tank, and operator. Operating weights for the 621K and 631K are based on Tier 4 Final/Stage IV/Japan 2014 (Tier 4 Final) platform machines. Deduct 243 kg (536 lb) for the operating weight for the 621K Tier 2/Stage II/Japan 2001 (Tier 2) equivalent. Deduct 430 kg (950 lb) for the operating weight for the 631K Tier 2/Stage II/Japan 2001 (Tier 2) equivalent.

NOTE: Wheel Tractor-Scrapers are not emission certified in Japan market.

**Single Engine Open Bowl**

The Open Bowl Wheel Tractor-Scraper is available as a self-loading, 631K push pull or push-loaded hauling system with a broad material appetite. The broad material appetite allows the Open Bowl Wheel Tractor-Scraper to be used in general construction, heavy construction, mining, and waste applications.

**Open Bowl Advantages:**

- Quick load/unload
- Spread evenly on-the-go
- Broad material appetite
- Aids in compaction
- Varying material conditions
- High production

**Single Engine Advantages**

**(Compared to Tandem Engine):**

- Lower fuel usage
- Lower gross vehicle weight
- Loads quickly with the aid of a Track-Type Tractor and hauls to fill carrying minimum machine weight

# Wheel Tractor-Scrapers

## Specifications

- Twin Engine Open Bowl
- Optional Push-Pull

MODEL	627K		637K		657G	
Flywheel Power: Tractor	304 kW	<b>407 hp</b>	425 kW	<b>570 hp</b>	421/447 kW	<b>564/600 hp</b>
Scraper	216 kW	<b>290 hp</b>	216 kW	<b>290 hp</b>	306/337 kW	<b>410/451 hp</b>
Approx. Operating Weight (Empty)◀	40 811 kg	<b>89,973 lb</b>	52 140 kg	<b>114,950 lb</b>	68 384 kg	<b>150,760 lb</b>
Scraper Capacity: Struck	13 m <sup>3</sup>	<b>17.1 yd<sup>3</sup></b>	18.3 m <sup>3</sup>	<b>24 yd<sup>3</sup></b>	24.5 m <sup>3</sup>	<b>32 yd<sup>3</sup></b>
Heaped	18.4 m <sup>3</sup>	<b>24 yd<sup>3</sup></b>	26 m <sup>3</sup>	<b>34 yd<sup>3</sup></b>	33.6 m <sup>3</sup>	<b>44 yd<sup>3</sup></b>
Rated Load	26 127 kg	<b>57,610 lb</b>	37 285 kg	<b>82,200 lb</b>	47 174 kg	<b>104,000 lb</b>
Weight Distribution — Empty: Front		<b>59%</b>		<b>59%</b>		<b>58%</b>
Rear		<b>41%</b>		<b>41%</b>		<b>42%</b>
Weight Distribution — Loaded: Front		<b>50%</b>		<b>50%</b>		<b>50%</b>
Rear		<b>50%</b>		<b>50%</b>		<b>50%</b>
Engine Model: Tractor	<b>C13 ACERT</b>		<b>C18 ACERT</b>		<b>C18 ACERT</b>	
Scraper	<b>C9.3 ACERT</b>		<b>C9 ACERT</b>		<b>C15 ACERT</b>	
Emission Standards	<b>Tier 4 Final/Stage IV/ Japan 2014 (Tier 4 Final)</b>		<b>Tier 4 Final/Stage IV/ Japan 2014 (Tier 4 Final)</b>		<b>Tier 3/Stage IIIA/ Japan 2006 (Tier 3) equivalent</b>	
Rated Engine RPM: Tractor	<b>2000</b>		<b>1900</b>		<b>1800</b>	
Scraper	<b>2150</b>		<b>2150</b>		<b>1800</b>	
Displacement: Tractor	12.5 L	<b>763 in<sup>3</sup></b>	18.1 L	<b>1105 in<sup>3</sup></b>	18.1 L	<b>1105 in<sup>3</sup></b>
Scraper	9.3 L	<b>567 in<sup>3</sup></b>	9.3 L	<b>567 in<sup>3</sup></b>	15.2 L	<b>928 in<sup>3</sup></b>
Top Speed (Loaded)	53.9 km/h	<b>33.5 mph</b>	55.8 km/h	<b>34.7 mph</b>	53 km/h	<b>33 mph</b>
180° Curb-to-Curb Turning Width	18.25 m	<b>59'11"</b>	19.94 m	<b>65'5"</b>	22.33 m	<b>73'3"</b>
Tires — Tractor/Scraper	<b>33.25R29**E3</b>		<b>37.25R35**E3</b>		<b>40.5/75R39**E3</b>	
Width of Cut	3.14 m	<b>10'4"</b>	3.51 m	<b>11'6"</b>	3.85 m	<b>12'8"</b>
Maximum Depth of Cut	315 mm	<b>12.4"</b>	475 mm	<b>18.7"</b>	440 mm	<b>17.3"</b>
Maximum Depth of Spread	540 mm	<b>21.3"</b>	451 mm	<b>17.8"</b>	660 mm	<b>26"</b>
Fuel Tank Refill Capacity	1272 L	<b>336 U.S. gal</b>	1400 L	<b>370 U.S. gal</b>	1597 L	<b>424 U.S. gal</b>
Tractor DEF Tank	31.5 L	<b>8.3 U.S. gal</b>	31.5 L	<b>8.3 U.S. gal</b>		—
Scraper DEF Tank	23.1 L	<b>6.1 U.S. gal</b>	22.9 L	<b>6.0 U.S. gal</b>		—
<b>GENERAL DIMENSIONS:</b>						
Non Push-Pull						
Height — Overall Shipping	4.03 m	<b>13'2"</b>	4.15 m	<b>13'7"</b>	4.62 m	<b>15'2"</b>
Wheelbase	7.99 m	<b>26'2"</b>	8.81 m	<b>28'11"</b>	9.96 m	<b>32'8"</b>
Overall Length	14.02 m	<b>45'10"</b>	15.04 m	<b>49'4"</b>	16.2 m	<b>53'1"</b>
Overall Width	3.57 m	<b>11'7"</b>	3.94 m	<b>12'11"</b>	4.35 m	<b>14'4"</b>
Shipping Width (Draft Arm on Inside of Bowl)		—		—	3.91 m	<b>* 12'10"</b>
Center Line of Scraper Tread	2.29 m	<b>7'5"</b>	2.46 m	<b>8'1"</b>	2.81 m	<b>9'3"</b>
Center Line of Tractor Tread	2.28 m	<b>7'4"</b>	2.46 m	<b>8'1"</b>	2.63 m	<b>8'8"</b>
<b>GENERAL DIMENSIONS: Push-Pull</b>						
Operating Weight (Empty)◀	42 158 kg	<b>92,942 lb</b>	54 005 kg	<b>119,060 lb</b>	72 804 kg	<b>160,505 lb</b>
Overall Length	15.58 m	<b>51'1"</b>	16.64 m	<b>54'7"</b>	18.01 m	<b>59'1"</b>
Weight Distribution — Empty:						
Front		<b>59%</b>		<b>61%</b>		<b>58%</b>
Rear		<b>41%</b>		<b>39%</b>		<b>42%</b>
Weight Distribution — Loaded:						
Front		<b>50%</b>		<b>51%</b>		<b>51%</b>
Rear		<b>50%</b>		<b>49%</b>		<b>49%</b>

\*Standard Shipping Configuration.

◀ Operating weight includes standard machine, coolant, lubricants, full fuel tank, and operator. Operating weights for the 627K and 637K are based on Tier 4 Final/Stage IV/Japan 2014 (Tier 4 Final) platform machines. Deduct 569 kg (**1254 lb**) for the operating weight for the 627K Tier 2/Stage II/Japan 2001 (Tier 2) equivalent. Deduct 650 kg (**1433 lb**) for the operating weight for the 637K Tier 2/Stage II/Japan 2001 (Tier 2) equivalent. 657G is not available in Tier 2/Stage II/Japan 2001 (Tier 2) equivalent.

**NOTE:** Wheel Tractor-Scrapers are not emission certified in Japan market.

- Specifications
- Twin Engine Open Bowl
  - Optional Push-Pull

## Twin Engine Open Bowl

The Open Bowl Wheel Tractor-Scraper is available as a self-loading, push-loaded, or push-pulled hauling system with a broad material appetite. The broad material appetite allows the Open Bowl Wheel Tractor-Scraper to be used in general construction, heavy construction, mining, and waste applications.

### Open Bowl Advantages:

- Quick load/unload
- Spread evenly on-the-go
- Broad material appetite
- Aids in compaction
- High Production
- Varying material conditions
- High production

### Twin Engine Advantages

#### (Compared to Single Engine):

- More power for loading, traveling up grades, or over fill area
- Faster cycle times
- High rolling resistance applications
- Variable site conditions
- Poor underfoot conditions
- Steep grades
- Can be self-loaded, push loaded with the aid of a Track-Type Tractor, or push-pulled



MODEL	637K		657G	
Flywheel Power: Tractor	425 kW	<b>570 hp</b>	421/447 kW	<b>564/600 hp</b>
Scrapper	216 kW	<b>290 hp</b>	306/337 kW	<b>410/451 hp</b>
Approx. Operating Weight (Empty)	53 425 kg	<b>117,782 lb</b>	72 190 kg	<b>158,817 lb</b>
Scrapper Capacity: Struck	31 m <sup>3</sup>	<b>41 yd<sup>3</sup></b>	45 m <sup>3</sup>	<b>59 yd<sup>3</sup></b>
Heaped	38 m <sup>3</sup>	<b>50 yd<sup>3</sup></b>	56 m <sup>3</sup>	<b>73 yd<sup>3</sup></b>
Emission Standards	<b>Tier 4 Final/Stage IV/ Japan 2014 (Tier 4 Final)</b>		<b>Tier 3/Stage IIIA/ Japan 2006 (Tier 3) equivalent</b>	
Rated Load	37 285 kg	<b>82,200 lb</b>	49 895 kg	<b>110,000 lb</b>
Approx. Operating Weight (Loaded)	90 710 kg	<b>199,982 lb</b>	121 933 kg	<b>268,817 lb</b>
Top Speed (Loaded)	55.8 km/h	<b>34.7 mph</b>	53 km/h	<b>33 mph</b>
180° Curb-to-Curb Turning Width	21.46 m	<b>70'5"</b>	24.43 m	<b>80'2"</b>
GENERAL DIMENSIONS:				
Height — Overall Shipping	4.15 m	<b>13'7"</b>	4.62 m	<b>15'2"</b>
Wheelbase	9.57 m	<b>31'5"</b>	11.01 m	<b>36'1"</b>
Overall Length	15.48 m	<b>50'10"</b>	17.21 m	<b>56'5"</b>
Overall Width	3.94 m	<b>12'11"</b>	4.35 m	<b>14'4"</b>
Shipping Width (Draft Arm on Inside of Bowl)		—	3.91 m	* <b>12'10"</b>
Center Line of Scrapper Tread	2.46 m	<b>8'1"</b>	2.81 m	<b>9'3"</b>
Center Line of Tractor Tread	2.46 m	<b>8'1"</b>	2.63 m	<b>8'8"</b>

\*Standard Shipping Configuration.

◀ Operating weight includes standard machine, coolant, lubricants, full fuel tank, and operator. Operating weights for the 637K are based on Tier 4 Final/Stage IV/Japan 2014 (Tier 4 Final) and operating weights for the 657G are based on Tier 3/Stage IIIA/Japan 2006 (Tier 3) equivalent platform machines. Deduct 650 kg (**1433 lb**) for the operating weight for the 637K Tier 2/Stage II/Japan 2001 (Tier 2) equivalent.

**NOTE:** Wheel Tractor-Scrapers are not emission certified in Japan market.

### Coal Bowl

Coal Bowl Wheel Tractor-Scrapers are typically used for building and maintaining coal stockpiles and hauling coal to the supply system at coal power plants. The self-loading capability, large capacity, coal pile compaction, and high speed of Coal Bowl Wheel Tractor-Scrapers make them the tool of choice for moving coal both short and long distances. Coal Bowl Wheel Tractor-Scrapers are available in the 637K and 657G tandem engine models.

### Coal Bowl Advantages:

- Load hoppers
- Manage coal stockpiles
- Compaction reduces risk of spontaneous combustion in coal stockpile
- Exclusively designed large capacity coal bowls

### Notes:

- The 637K Coal Scraper is 736 mm (**29.0"**) longer, the bowl sides are 476 mm (**18.7"**) taller, and the apron is 499 mm (**19.6"**) taller than its earthmoving counterpart.
- The 657G Coal Scraper is 1072 mm (**42.2"**) longer, the bowl sides are 1010 mm (**39.8"**) taller, the apron is 677 mm (**26.7"**) taller, and the ejector is 944 mm (**37.2"**) taller than its earthmoving counterpart.

- Router Bits
- Cutting Edges

## WHEEL TRACTOR-SCRAPER GROUND ENGAGING TOOLS

### ROUTER BITS

Cat® router bits help prevent wear and costly damage to the scraper bowl. All router bits are forged DH-2 steel and through-hardened to prevent breakage and prolong life.



#### Standard Router Bit

- Available for all models.



#### Heavy Duty Router Bit

- 45% more wear material than the standard router bits.



#### ARM Router Bit

- Available for virtually all models in high abrasion, low impact applications.



#### Level Router Bit

- Used for clean-up work and keeps material in front of the cutting edges.

### CUTTING EDGES

Cat cutting edges are rolled from DH-2 steel and through-hardened for strength and wear resistance and are available in standard, abrasion resistant material (ARM), and serrated versions.



#### Standard center and end-cutting edges

- For use on all scraper models (open bowl, auger and elevating scraper).
- Used in low-to-medium abrasion and low-to-high impact conditions.
- Available in various thicknesses and sizes for both stinger and level-cut arrangements.
- Can be reversed or propellered for prolonged edge use and improved cost per hour.



#### ARM center and end cutting edges

- For use on all scraper models (open bowl, auger and elevating scraper).
- Used in medium-to-high abrasion and low-to-high impact conditions.
- Available in various thicknesses and sizes for both stinger and level-cut arrangements.
- Can be reversed or propellered for prolonged edge use and improved cost per hour.



#### **ARM serrated center cutting edge**

- For use on 620, 630 and 650 Series Scraper (open bowl, auger and elevating scraper).
- Used in medium-to-high abrasion and medium-to-high impact conditions where increased penetration and aggressive digging action is required.
- Available in various thicknesses and sizes for both stinger and level-cut arrangements.
- Edges can be reversed or propellered around for prolonged edge use and improved cost per hour.



#### **Special serrated cutting edges**

- For site-specific applications and conditions.
- Use on 620, 630 and 650 Series Scraper (open bowl, auger and elevating scraper).
- Custom-designed edges have sharp teeth for low-to-medium abrasion and low-to-medium impact conditions.



#### **Integrated tooth center cutting edge**

- For use on 623 and 633 Elevating Scraper, and 620 Series Auger Scraper.
- Used in low-to-high abrasion conditions for improved penetration in medium-to-high impact conditions.
- Include cast-in-place adapters, which accept pin-on tips.



#### **Bolt-on adapters**

- For use on Elevating Scraper 613, 615, 623 and 633.
- Used in low-to-high abrasion conditions and low-to-medium impact conditions when improved penetration is needed.
- Bolt-on adapters accept pin-on tips.

- Bowl Side Protectors
- Elevating Scraper

### BOWL SIDE PROTECTORS

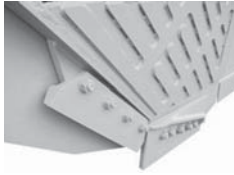

- Bowl Side protectors are available in two styles: Bolt on bowl side protectors and pin on bowl side protectors.
- Bolt on style takes a weld on adapter plate that accepts the bolt on bowl side protector. This is available for 620, 630 and 650 Series scrapers.
- Pin on style takes a weld on adapter plate that accepts the pin on bowl side protector. This is available for 620, 630 and 650 Series scrapers.

### ELEVATING SCRAPER



- Flight assemblies.
- Chain assemblies.\*
- Sprockets.\*
- Idlers and idler groups.
- Rollers and roller groups.

\*Optional heavy-duty chain and sprocket for 623K available through your Cat dealer.

In today's competitive environment, machines must operate efficiently. Inspections identify problems that cause machines to burn more fuel and shorten component life.

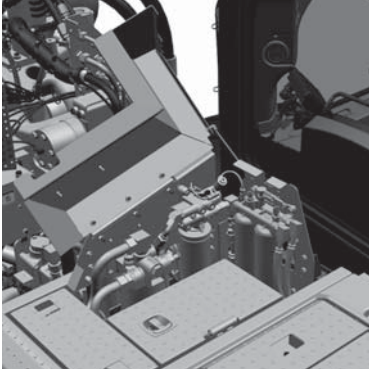
**K SERIES FEATURES AND BENEFITS**



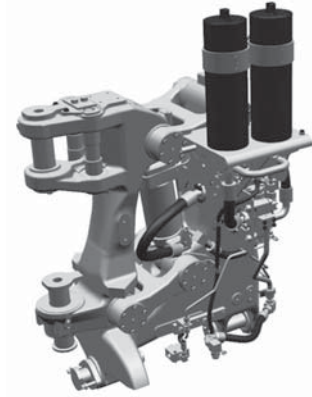



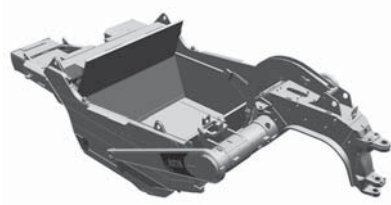























































- **Tractor Serviceability Improvement** — The filter bank located at the rear of the engine compartment has undergone improvements for serviceability by raising the filter bank up for easier access.
- **Engine Over Speed Protection** — In the event of an engine over speed situation, the compression brake will automatically engage with no operator input. The machine determines the over speed condition based on rate of acceleration and applies compression brake automatically.
- **Fuel Economy Mode** — Fuel Economy Mode is a two part feature when selected, the first part of the feature lowers the transmission shift points allowing shifting to take place at lower rpms to aid in fuel savings. The second part of the Fuel Economy Mode allows the machine when operated at engine rpms less than full throttle to automatically vary the power distribution between the tractor and the scraper, allowing the machine to utilize the more efficient tractor power train vs. the full time torque converter drive scraper power train.













- **Advanced Cushion Hitch** — With similar technology as the Cat Advanced Ride Management seat suspension, this software allows the cushion hitch to prevent end stroke by having the ability to predict end stroke events and manage the rate of dampening. The desired result is improved hitch repair, reduced maintenance and improved operator ride in rough conditions.
- **High Pressure Steering** — The K Series steering system design requires significantly less steering effort. The reduced steering effort allows for decreased operator fatigue and a more efficient operator resulting in possible higher rates of production late in the work cycle.

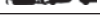

- **Draft Arm Overflow Guards** — The open bowls now come standard with bowl side overflow guards to help prevent material from flowing over the bowl sides and falling onto the draft arms where material becomes embedded between the bowl side and draft arm resulting in decreased work cycle times.
- **Auto Stall** — In cold weather conditions the machine will use the Auto Stall feature to help warm up the transmission oil faster resulting in the machine shifting out of torque converter drive (2nd gear) faster than on previous models.
- **Differential Lock Engagement Protection (Standard)** — This standard feature allows the machine to prevent the operator from engaging the differential lock when damage could occur.
- **Cab Improved** — The interior of the K Series cabs has improved the operator comfort and visibility by redesigning the dash area and key pad placement.
- **Machine Speed Limit** — This feature is designed to take the place of top gear selection. If the machine top speed needs to be limited the operator can select the top speed through the display or the top speed can be set in ET. This will allow the machine to find the correct gear that works best for the engine and transmission. Allowing the engine and transmission to select the correct gear to pull the load in most cases resulting in a lower engine load factor and lower fuel burn verses using top gear selection that required the machine to run at engine speeds at or close high idle.
- **Ground Speed Control** — Ground Speed Control sets the desired top speed by the operator if job site conditions or segment speed limits require a speed less than full run out. Machine Speed Limit is intended for use when top speed needs to be limited for longer durations and Ground Speed Control is intended for use when the top speed needs to be reduced for shorter segments or intermediate periods of time. The operator can set the desired top speed and the machine will find the correct gear that works best for the engine and transmission. Allowing the engine and transmission to select the correct gear to pull the load in most cases will result in a lower engine load factor and lower fuel burn verses top gear selection.

Material Application Guide	Elevator	Self-Load Single and Tandem Engine	Push-Load Single and Tandem Engine	Push Pull	Auger Tandem Engine	Coal Bowl	Remarks
Decomposed Granite/Soil							Excellent loading
Decomposed Granite (Ripped)							Excellent loading by push-loading or push-pull to reduce cutting of tires
Moist Top Soil							Good to Excellent Loading
Top Soil							Excellent for WTS
Clay/Sand Mixture							Excellent for WTS
Sand							Good to Excellent loading, but some cases may need to be push loaded by a TTT or Push-Pull
Antigo							Excellent WTS material: lower portion may require ripping depending on material density
Coal							Excellent for WTS: ripping may be required in dense material
Limestone							In natural state, not suitable for WTS
Granite							Not suitable for WTS
Sandstone							For WTS to be productive in sandstone, material needs to be ripped. In some cases where density is high, WTS would not be a good fit
Shot Rock							Below 610 mm (24") good for WTS when push-loaded by a TTT to reduce cutting of tires
Loess Overtill (Banked)							Excellent for WTS: ripping may be required in dense material
Loess Overtill (Ripped)							Excellent WTS material provided rock size does not exceed 610 mm (24")
Aridisols							Excellent WTS material, ripping will decrease load times
Glacial Outwash/River Rock							Excellent WTS material provided rock size does not exceed 610 mm (24")

FOR MORE INFORMATION ON WHEEL TRACTOR-SCRAPER MATERIAL APPLICATIONS REFERENCE PUBLICATION AEXQ0442.

Push-Load TTT Match	D8	D9	D10	D11
621				
627				
631				
637				
657				

MODEL TIRE SIZE	PLY RATING/ STAR RATING*	TYPE
<b>621K</b>	★★	E-3
<b>623K</b>		
33.25R29◀	★★	E-3
33.25-29	32	E-3
<b>627K</b>		
33.25R29◀	★★	E-3

MODEL TIRE SIZE	PLY RATING/ STAR RATING*	TYPE
<b>631K</b>		
<b>637K</b>		
37.25R35◀	★★	E-3
<b>657G</b>		
40.5/75R39◀	★★	E-3

\*Manufacturer uses star (★) rating system instead of ply rating.

◀Recommended tire.



**CUSHION HITCH**

- Cushion Hitch dampens shocks to provide a smoother ride
- Nitrogen over oil accumulators absorb and dampen road shock

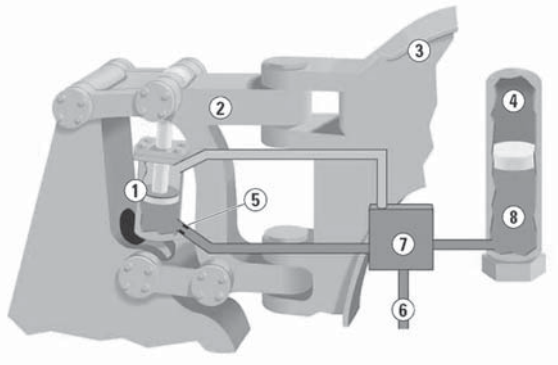

1. Load Cylinder
2. Hitch Castings
3. Scraper Gooseneck
4. Nitrogen Accumulators
5. Orifice
6. Oil from Tractor Hydraulic System
7. Leveling Valve
8. Free-Floating Pistons

**WHEEL TRACTOR-SCRAPER ANATOMY**

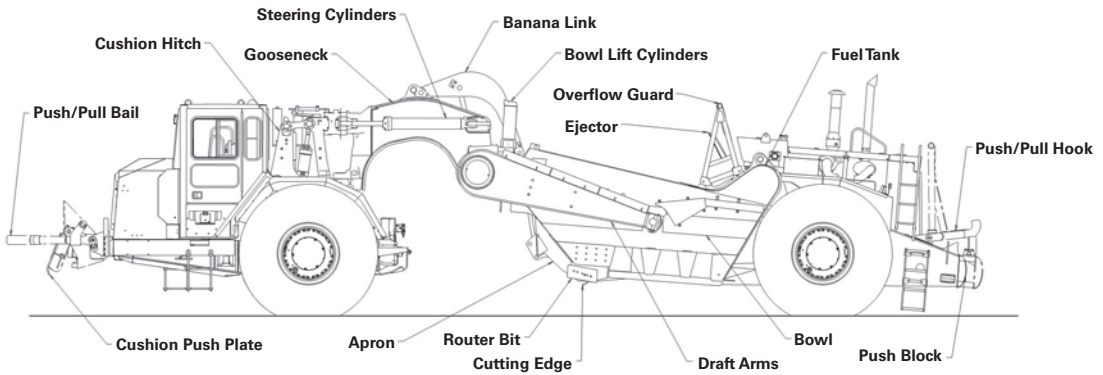

**USE OF RIMPULL-SPEED-  
GRADEABILITY CURVES**

*The following explanation applies to Rimpull-Speed-Gradeability curves for Wheel Tractor-Scrapers, Construction & Mining Trucks/Tractors and Articulated Trucks.*

Maximum speed attainable, gear range and available rimpull can be determined from curves on the following pages when machine weight and total effective grade (or total resistance) are known.

**Rimpull** is the force (in kg, lb or kN) available between the tire and the ground to propel the machine (limited by traction).

**Weight** is defined as Gross Machine Weight (kg or lb) = Machine + Payload.

**Total Effective Grade (or Total Resistance)** is grade resistance plus rolling resistance expressed as percent grade.

Grade is measured or estimated.

Rolling resistance is estimated (see Tables section for typical values.)

10 kg/metric ton (20 lb/U.S. ton) = 1% adverse grade.

Example

With a 6% grade and a rolling resistance of 40 kg/metric ton (80 lb/U.S. ton), find total resistance.

Rolling resistance = 40 kg/t ÷ 10 = 4% Effective Grade  
(English: 80 lb ÷ 20 = 4%)

Total resistance = 4% rolling + 6% grade = 10%

**Altitude Derating**

Rimpull force and speed must be derated for altitude similar to flywheel horsepower. The percentage loss in rimpull force approximately corresponds to the percentage loss in flywheel horsepower. See Tables Section for altitude derations.

**Rimpull-Speed-Gradeability**

To determine gradeability performance: Read from gross weight down to the % of total resistance. (Total resistance equals actual % grade *plus* 1% for each 10 kg/metric ton (20 lb/U.S. ton) of rolling resistance.) From this weight-resistance point, read horizontally to the curve with the highest obtainable speed range, then down to the maximum speed. Usable rimpull depends upon traction and weight on drive wheels.

Example problem:

A 631K with an estimated payload of 37 013 kg (81,600 lb) is operating on a total effective grade of 10%. Find the available rimpull and maximum attainable speed.

Empty weight payload = Gross Weight  
47 628 kg + 37 013 kg = 84 641 kg  
(105,002 lb + 81,600 lb = 186,602 lb)

*Solution:* Using graph on the next page, read from 84 641 kg (186,602 lb) (point A) on top of gross weight scale down the line to the intersection of the 10% total resistance line (point B).

Go across horizontally from B to the Rimpull Scale on the left (point D). This gives the required rimpull: 7756 kg (17,100 lb).

Where the line cuts the speed curve (point C), read down vertically (point E) to obtain the maximum speed attainable for the 10% effective grade: 12.9 km/h (8 mph).

ANSWER: The machine will climb the 10% effective grade at a maximum speed of 12.9 km/h (8 mph) in 4th gear. Available rimpull is 7756 kg (17,100 lb).



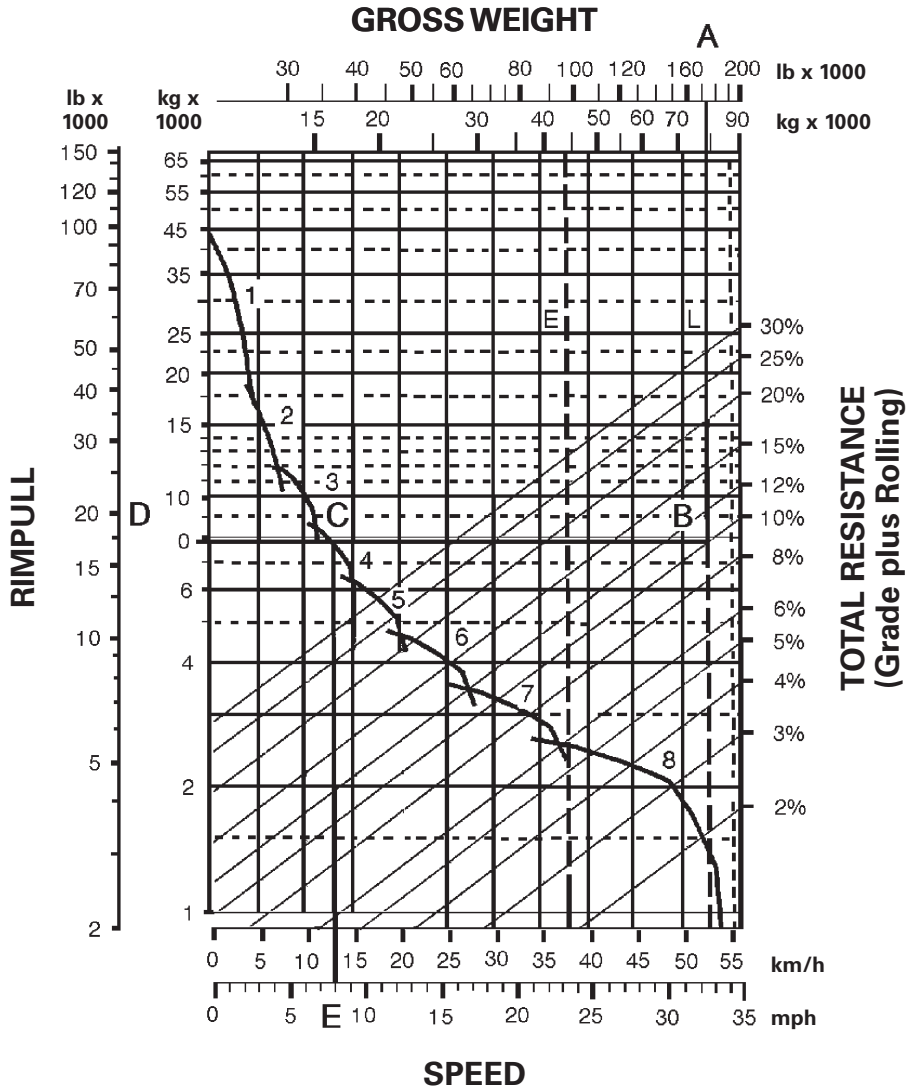

KEY

- 1 — 1st Gear Torque Converter Drive
- 2 — 2nd Gear Torque Converter Drive
- 3 — 3rd Gear Direct Drive
- 4 — 4th Gear Direct Drive
- 5 — 5th Gear Direct Drive
- 6 — 6th Gear Direct Drive
- 7 — 7th Gear Direct Drive
- 8 — 8th Gear Direct Drive

KEY

- A — Loaded 84 641 kg (186,602 lb)
- B — Intersection with 10% total resistance line
- C — Intersection with rimpull curve (4th gear)
- D — Required rimpull 7756 kg (17,100 lb)
- E — Speed 12.9 km/h (8 mph)

**TYPICAL FIXED TIMES FOR SCRAPERS**

(Times may vary depending on job conditions)

Model	Loaded By	Load Time (Min.)	Maneuver and Spread or Maneuver and Dump (Min.)
613G	Self	0.9	0.7
623K	Self	0.9	0.7
621K	One D8	0.5	0.7
627K	One D8	0.5	0.6
621K	One D9	0.4	0.7
627K	One D9	0.4	0.6
627K/PP	Self	0.9*	0.6
631K	One D9	0.6	0.7
637K	One D9	0.6	0.6
631K	One D10	0.5	0.7
637K	One D10	0.5	0.6
637K/PP	Self	1.0*	0.6
657G	One D11	0.6	0.6
657G	Push Pull Self	1.1*	0.6
637K	Coal	0.8	0.7
657G	Coal	0.8	0.6

\*Load time per pair, including transfer time.

**NOTE:** Empty Weights shown on the Wheel Tractor-Scraper charts includes ROPS Canopy. When calculating TMPH loadings any additional weight must be considered in establishing mean tire loads.

**USE OF RETARDER CURVES**

*The following explanation applies to retarder curves for Wheel Tractor-Scrapers and Articulated Trucks.*

The speed that can be maintained (without use of service brake) when the machine is descending a grade with retarder fully on can be determined from the retarder curves in this section if gross machine weight and total effective grade are known.

**Total Effective Grade (or Total Resistance)** is grade assistance *minus* rolling resistance.

10 kg/metric ton (20 lb/U.S. ton) = 1% adverse grade.

Example

15% favorable grade with 5% rolling resistance. Find Total Effective Grade.

$$\text{Total Effective Grade} = 15\% \text{ Grade Assistance} - 5\%$$

$$\text{Rolling Resistance} = 10\% \text{ Total Effective Grade Assistance.}$$

Example problem:

A 651E with an estimated payload of 47 175 kg (104,000 lb) descends a 10% total effective grade. Find constant speed and gear range with maximum retarder effort. Find travel time if the slope is 610 m (2000 ft) long.

$$\begin{aligned} \text{Empty Weight} + \text{Payload} &= \text{Gross Weight} \\ &= 60\,950 \text{ kg} + 47\,175 \text{ kg} = 108\,125 \text{ kg} \\ &= (134,370 \text{ lb} + 104,000 \text{ lb} = 238,370 \text{ lb}) \end{aligned}$$

*Solution:* Using the retarder curve below, read from 108 125 kg (238,370 lb) (point A) on top of gross weight scale down the line to the intersection of the 10% effective grade line (point B).

Go across horizontally from point B to the intersection of the retarder curve (point C). Point C intersects at the 5 (5th gear) range.

Where point C intersects the retarder curve, read down vertically to point D on the bottom scale to obtain the constant speed: 21.7 km/h (13.5 mph).

ANSWER: The 651E will descend the slope at 21.7 km/h (13.5 mph) in 5th gear. Travel time is 1.68 minutes.

$$\frac{610 \text{ m}}{363 \text{ m/min}} = 1.68 \text{ min}$$

\*(mph × 88 = F.P.M.)

$$\frac{2000 \text{ ft}}{13.5 \text{ mph} \times 88^*} = 1.68 \text{ min}$$

NOTE: The basic Distance-Speed-Time formula is  $60 D \div S = T$  (or “60 D Street”), where 60 is minutes, D is distance, S is speed and T is time. In the above problem,  $60 \times 610 \text{ m} \div 21.7 \text{ km/h} \times 1000 = T$ .

$$\frac{60 \times 610}{21.7 \times 1000} = T = (1.68)$$

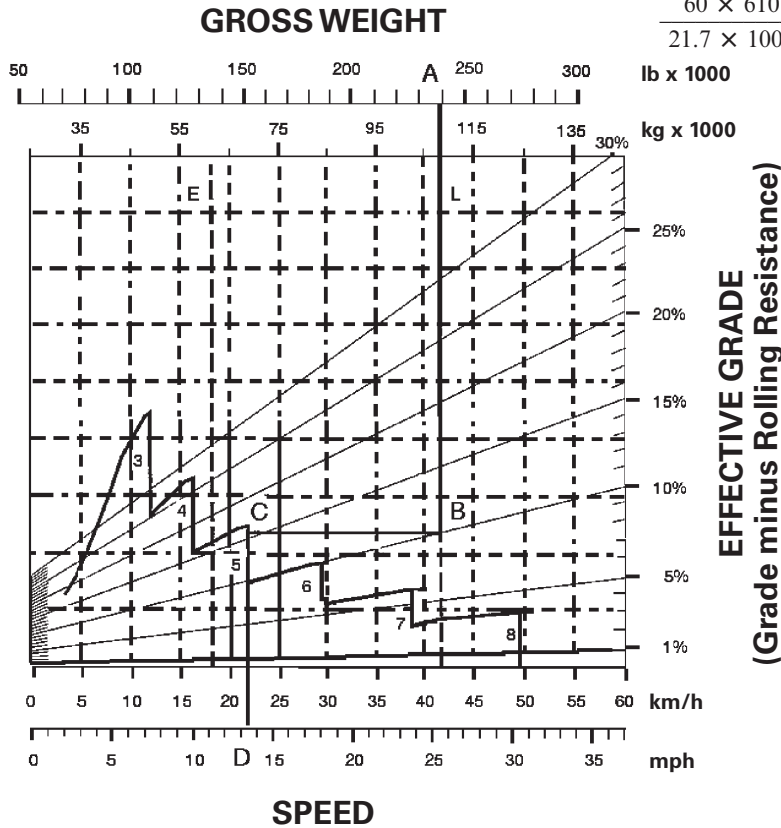

KEY

- 3 — 3rd Gear Direct Drive
- 4 — 4th Gear Direct Drive
- 5 — 5th Gear Direct Drive
- 6 — 6th Gear Direct Drive
- 7 — 7th Gear Direct Drive
- 8 — 8th Gear Direct Drive

KEY

- A — Loaded 108 125 kg (238,370 lb)
- B — Intersection with 10% effective grade line
- C — Intersection with retarder curve (5th gear)
- D — Constant speed 21.7 km/h (13.5 mph)

**STANDARD ARRANGEMENT\*  
 GROSS WEIGHT**

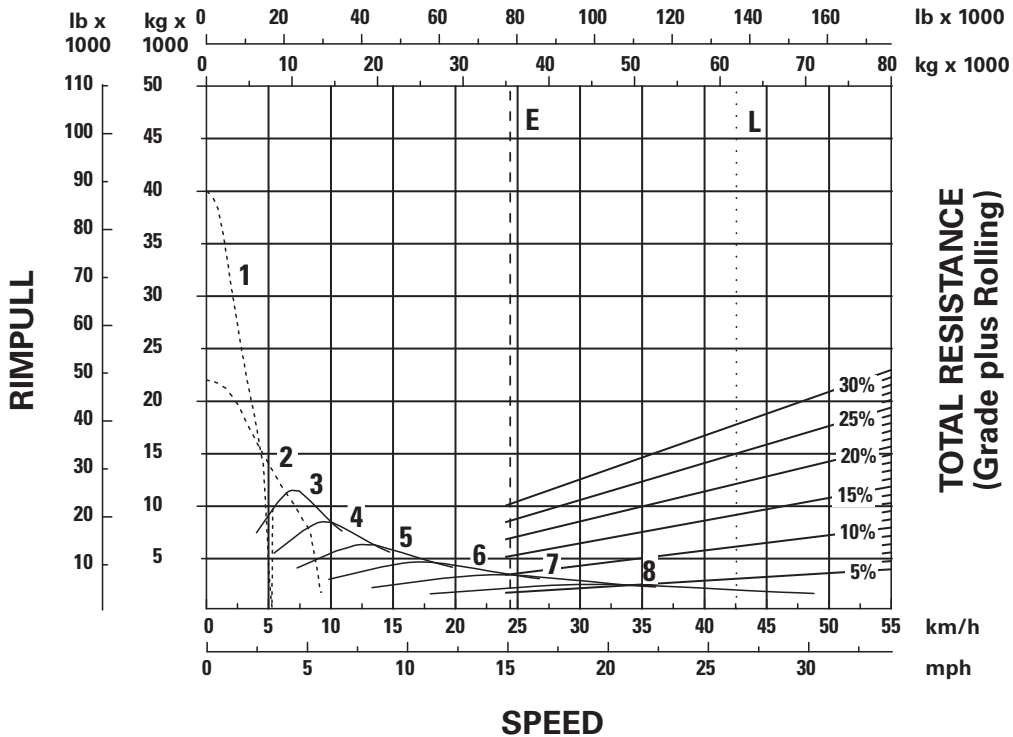

\*at sea level

**KEY**

- 1 — 1st Gear Torque Converter Drive
- 2 — 2nd Gear Torque Converter Drive
- 3 — 3rd Gear Direct Drive
- 4 — 4th Gear Direct Drive
- 5 — 5th Gear Direct Drive
- 6 — 6th Gear Direct Drive
- 7 — 7th Gear Direct Drive
- 8 — 8th Gear Direct Drive

**KEY**

- E — Empty 35 808 kg (78,943 lb)
- L — Loaded 61 935 kg (136,553 lb)

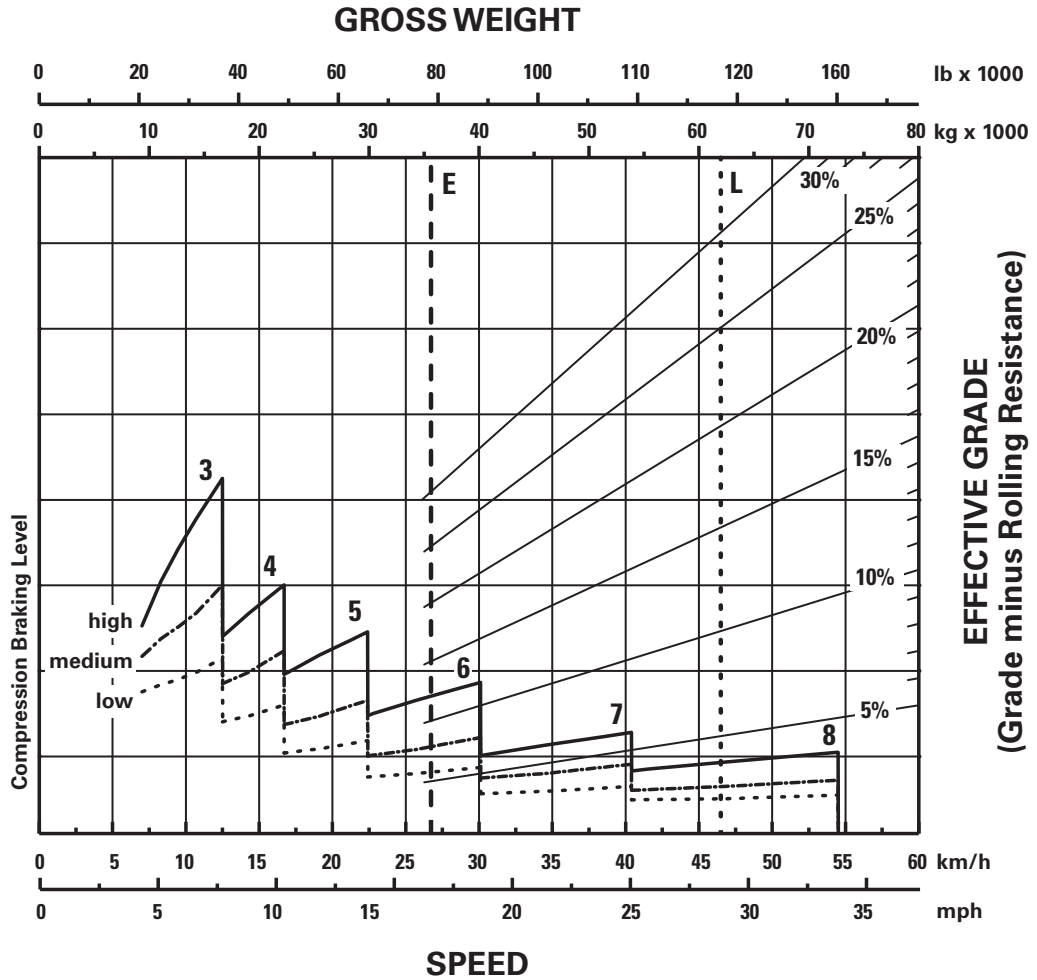

\*at sea level

KEY

- 3 — 3rd Gear Direct Drive
- 4 — 4th Gear Direct Drive
- 5 — 5th Gear Direct Drive
- 6 — 6th Gear Direct Drive
- 7 — 7th Gear Direct Drive
- 8 — 8th Gear Direct Drive

KEY

- E — Empty 35 808 kg (78,943 lb)
- L — Loaded 61 935 kg (136,553 lb)

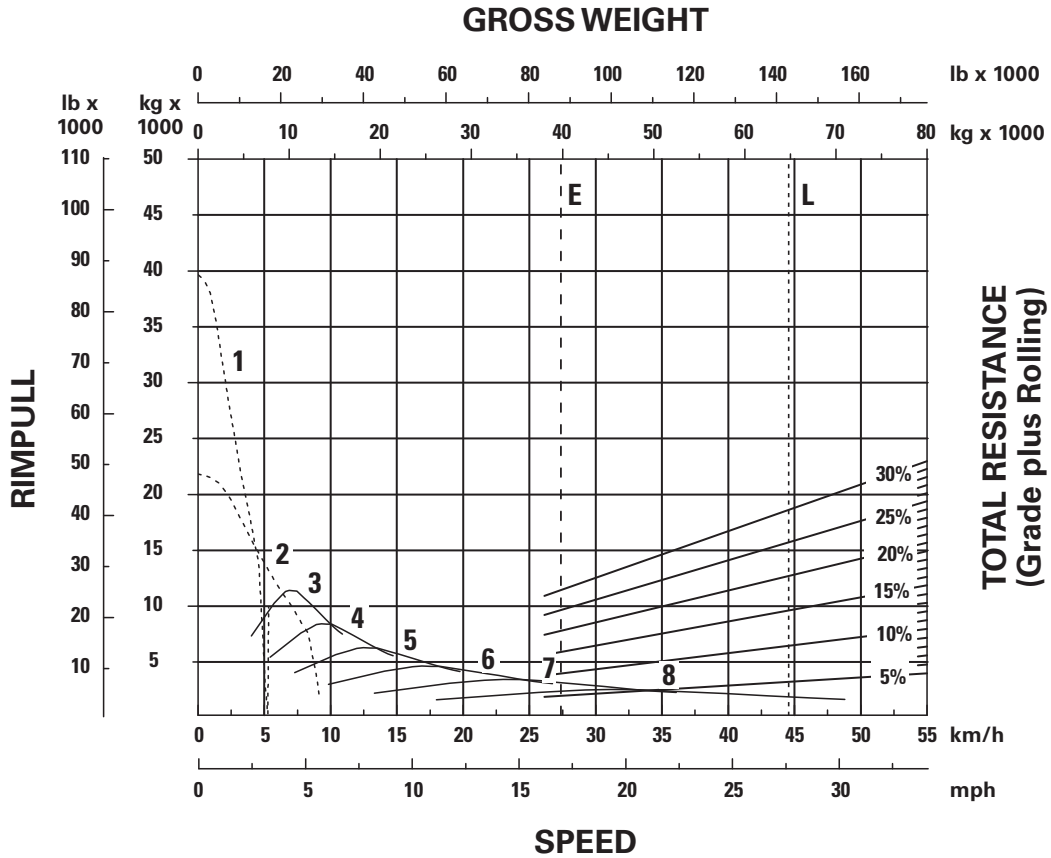

**KEY**

- 1 — 1st Gear Torque Converter Drive
- 2 — 2nd Gear Torque Converter Drive
- 3 — 3rd Gear Direct Drive
- 4 — 4th Gear Direct Drive
- 5 — 5th Gear Direct Drive
- 6 — 6th Gear Direct Drive
- 7 — 7th Gear Direct Drive
- 8 — 8th Gear Direct Drive

**KEY**

- E — Empty 39 866 kg ((87,809 lb)
- L — Loaded 64 904 kg (143,009 lb)



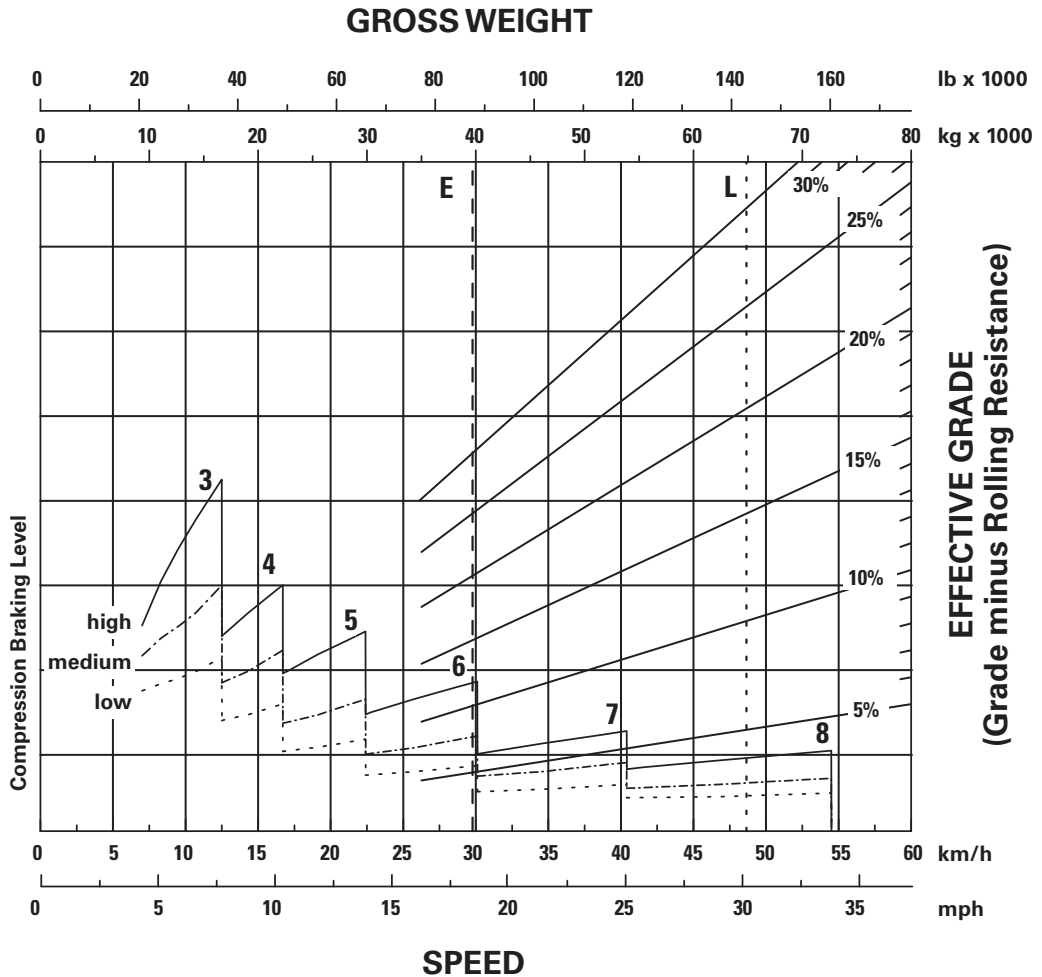

KEY

- 3 — 3rd Gear Direct Drive
- 4 — 4th Gear Direct Drive
- 5 — 5th Gear Direct Drive
- 6 — 6th Gear Direct Drive
- 7 — 7th Gear Direct Drive
- 8 — 8th Gear Direct Drive

KEY

- E — Empty 39 866 kg (87,809 lb)
- L — Loaded 64 904 kg (143,009 lb)

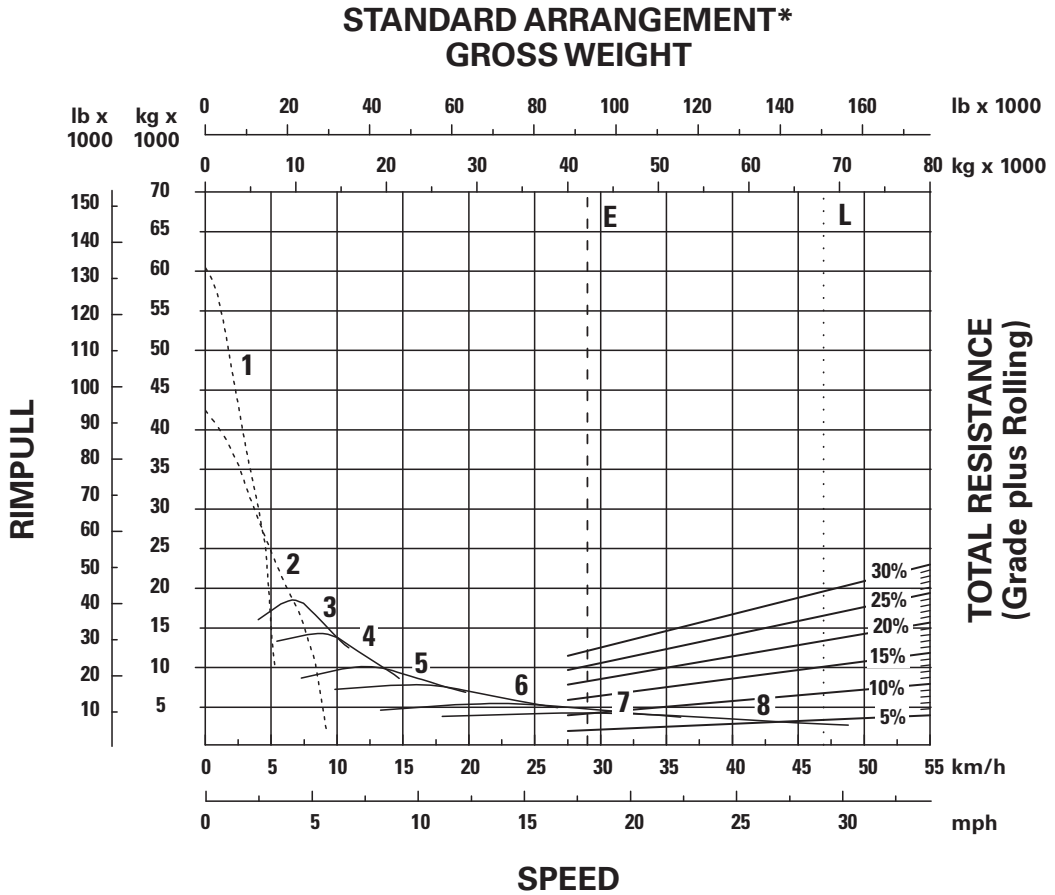

\*at sea level

**KEY**

- 1 — 1st Gear Torque Converter Drive
- 2 — 2nd Gear Torque Converter Drive
- 3 — 3rd Gear Direct Drive
- 4 — 4th Gear Direct Drive
- 5 — 5th Gear Direct Drive
- 6 — 6th Gear Direct Drive
- 7 — 7th Gear Direct Drive
- 8 — 8th Gear Direct Drive

**KEY**

- E — Empty 42 158 kg (92,942 lb)
- L — Loaded 68 289 kg (150,552 lb)

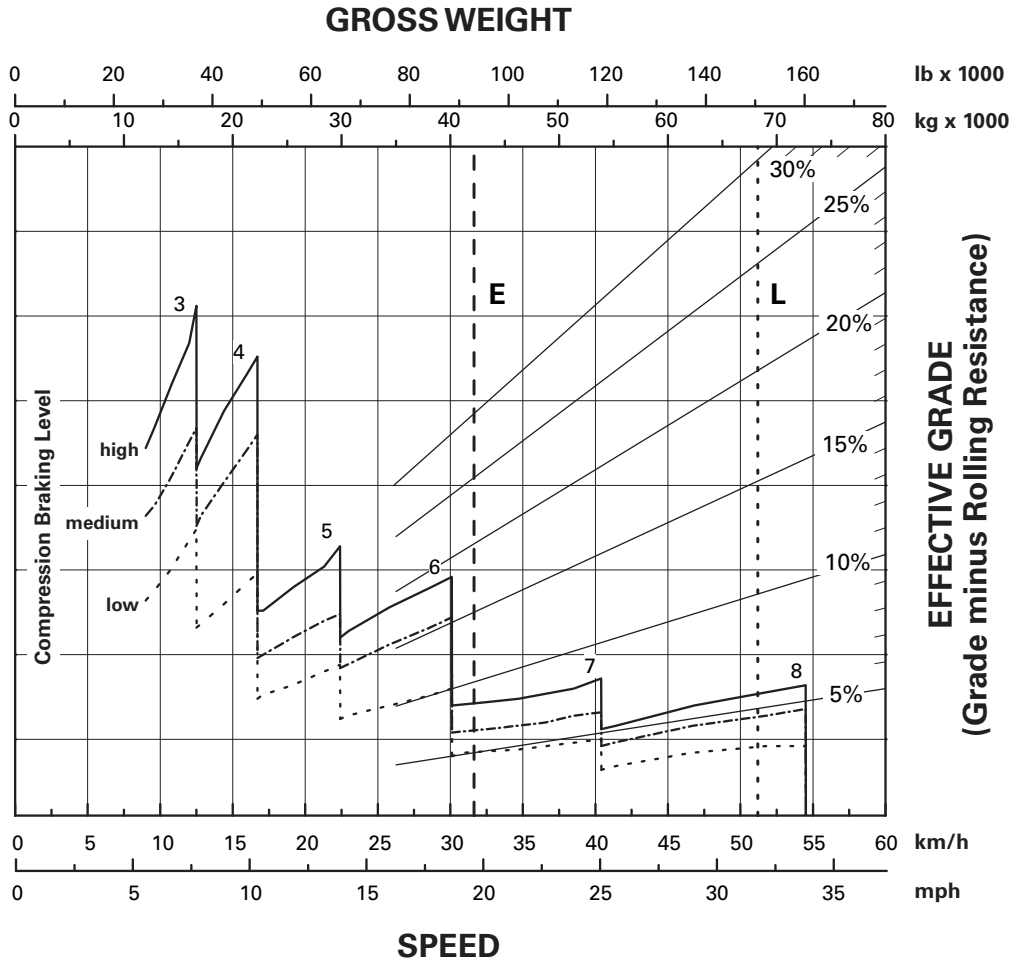

\*at sea level

**KEY**

- 3 — 3rd Gear Direct Drive
- 4 — 4th Gear Direct Drive
- 5 — 5th Gear Direct Drive
- 6 — 6th Gear Direct Drive
- 7 — 7th Gear Direct Drive
- 8 — 8th Gear Direct Drive

**KEY**

- E — Empty 42 158 kg (92,942 lb)
- L — Loaded 68 289 kg (150,552 lb)

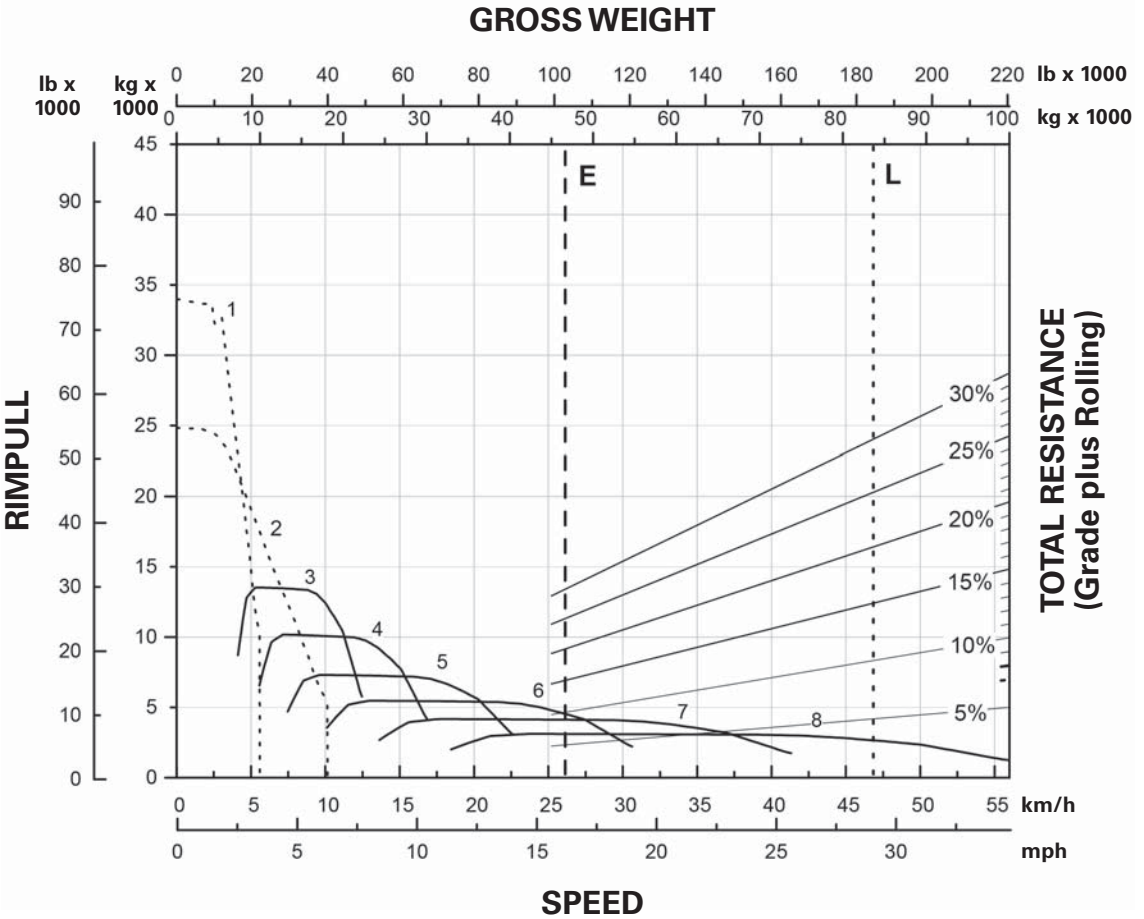

**KEY**

- 1 — 1st Gear Torque Converter Drive
- 2 — 2nd Gear Torque Converter Drive
- 3 — 3rd Gear Direct Drive
- 4 — 4th Gear Direct Drive
- 5 — 5th Gear Direct Drive
- 6 — 6th Gear Direct Drive
- 7 — 7th Gear Direct Drive
- 8 — 8th Gear Direct Drive

**KEY**

- E — Empty 46 607 kg (102,750 lb)
- L — Loaded 83 892 kg (184,950 lb)

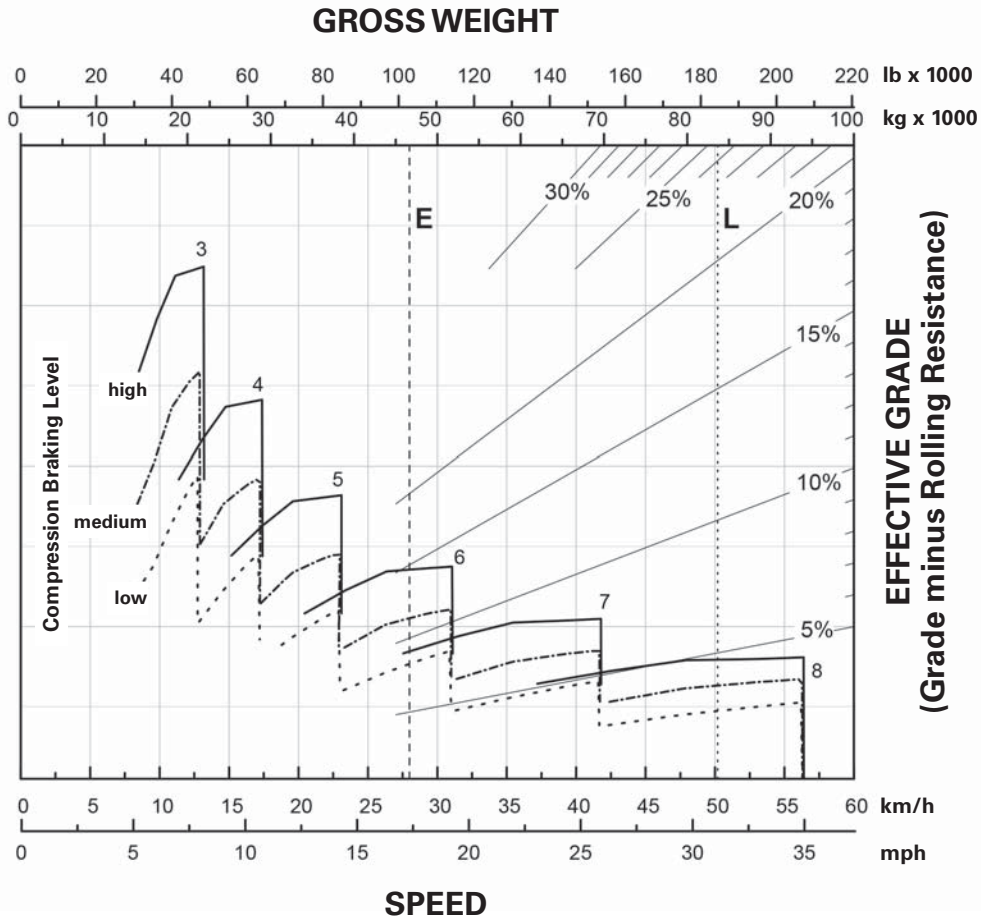

KEY

- 3 — 3rd Gear Direct Drive
- 4 — 4th Gear Direct Drive
- 5 — 5th Gear Direct Drive
- 6 — 6th Gear Direct Drive
- 7 — 7th Gear Direct Drive
- 8 — 8th Gear Direct Drive

KEY

- E — Empty 46 607 kg (102,750 lb)
- L — Loaded 83 892 kg (184,950 lb)

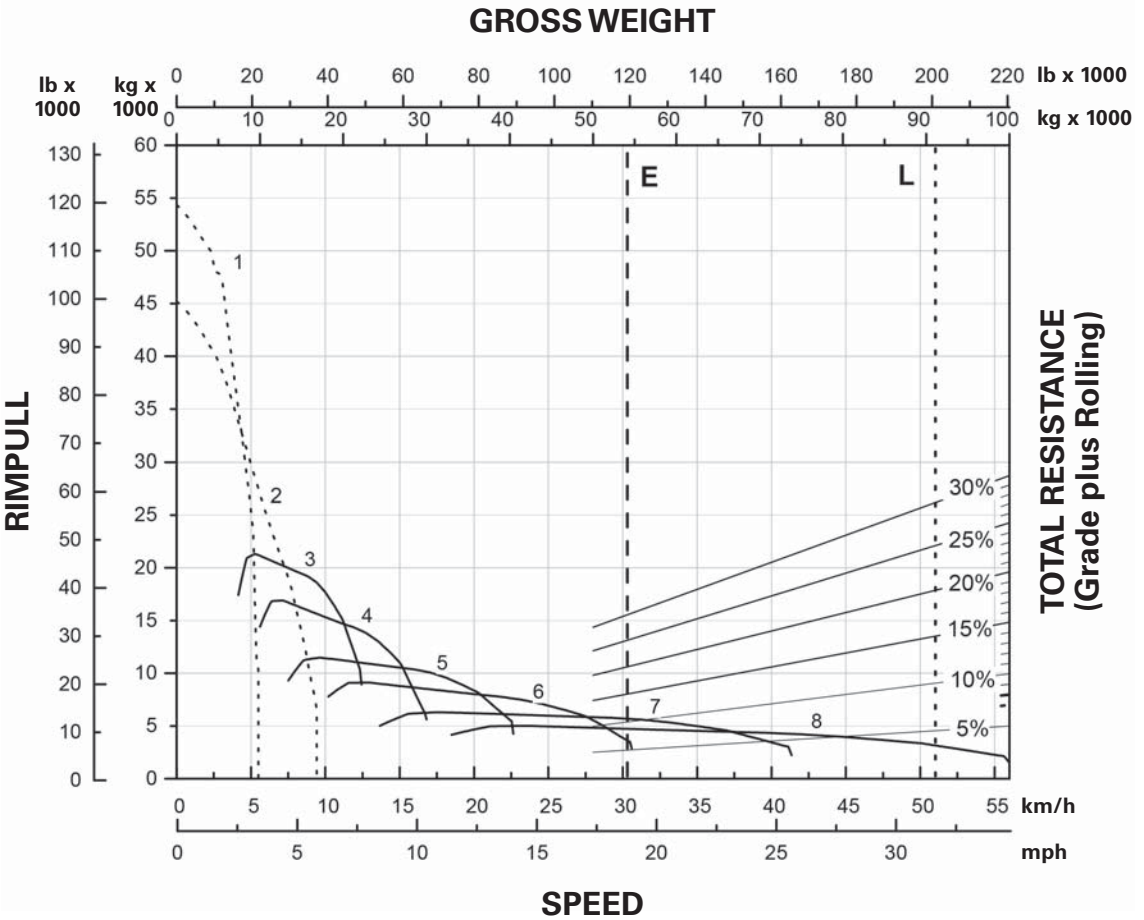

**KEY**

- 1 — 1st Gear Torque Converter Drive
- 2 — 2nd Gear Torque Converter Drive
- 3 — 3rd Gear Direct Drive
- 4 — 4th Gear Direct Drive
- 5 — 5th Gear Direct Drive
- 6 — 6th Gear Direct Drive
- 7 — 7th Gear Direct Drive
- 8 — 8th Gear Direct Drive

**KEY**

- E — Empty 54 005 kg (119,060 lb)
- L — Loaded 91 290 kg (201,260 lb)

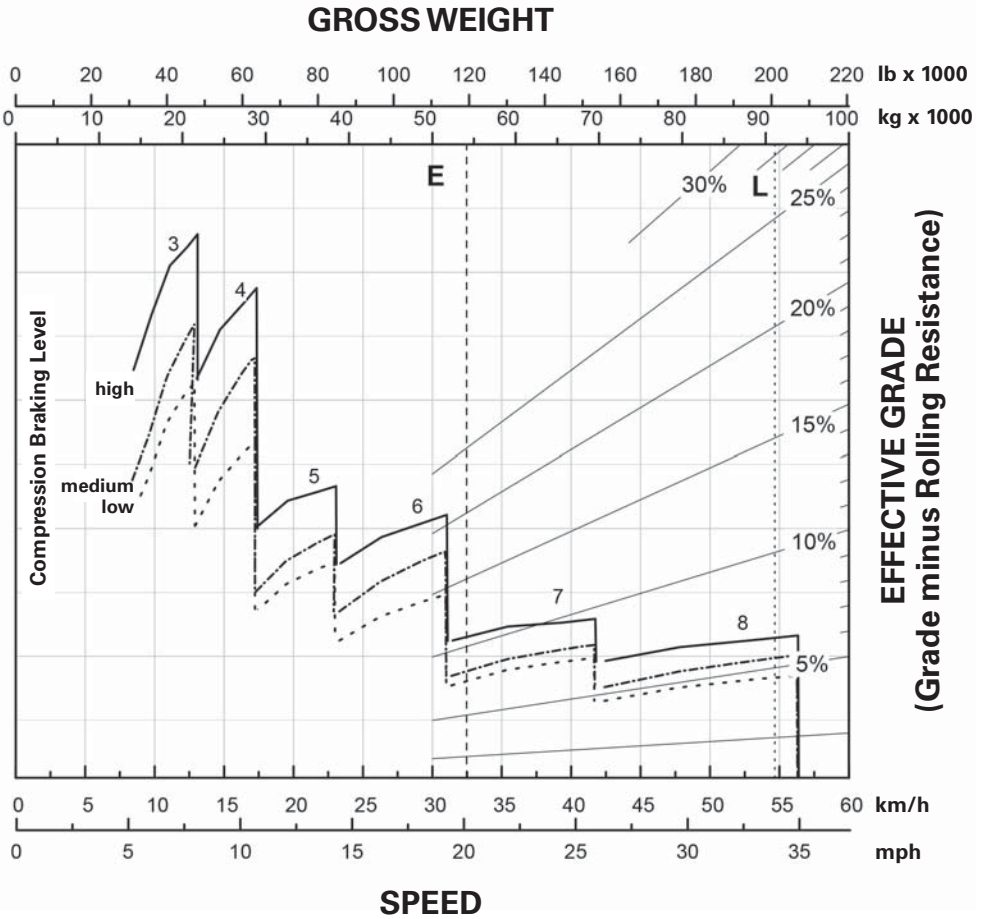

KEY

- 3 — 3rd Gear Direct Drive
- 4 — 4th Gear Direct Drive
- 5 — 5th Gear Direct Drive
- 6 — 6th Gear Direct Drive
- 7 — 7th Gear Direct Drive
- 8 — 8th Gear Direct Drive

KEY

- E — Empty 54 005 kg (119,060 lb)
- L — Loaded 91 290 kg (201,260 lb)

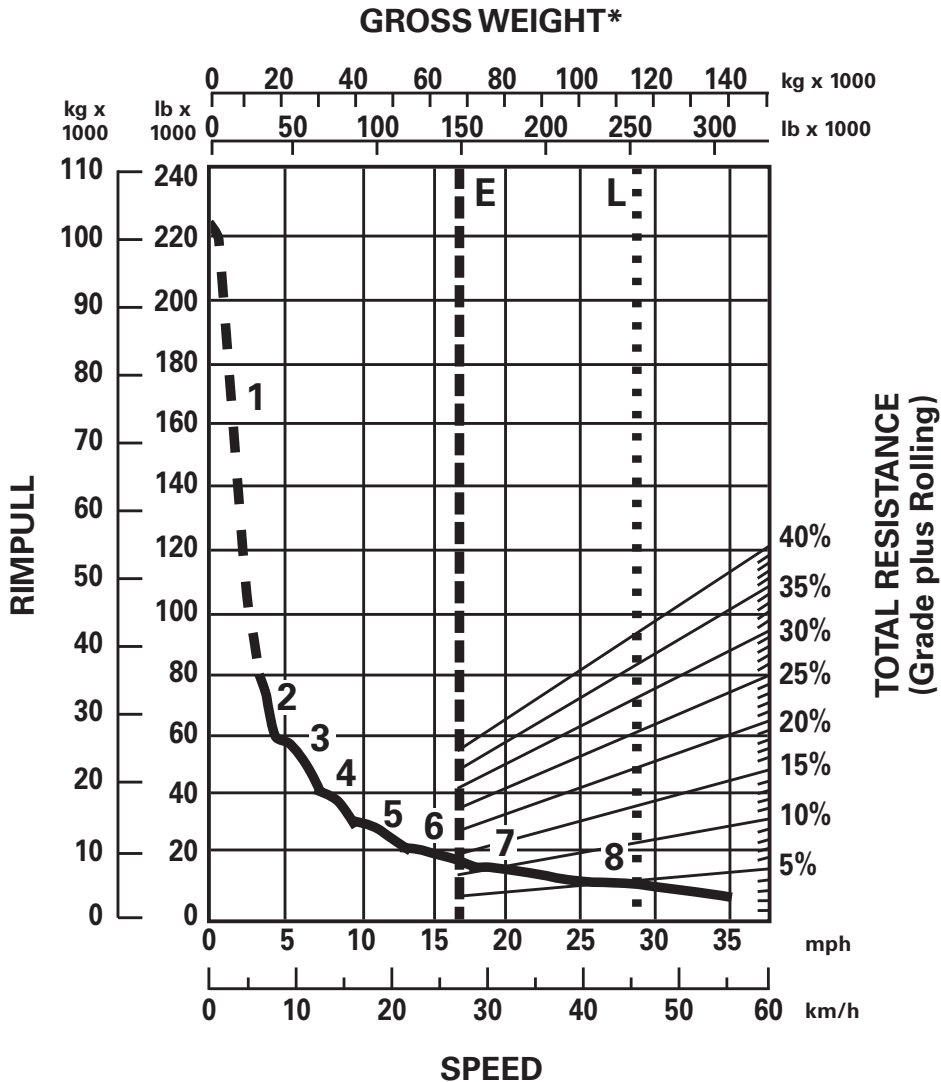

\*at sea level



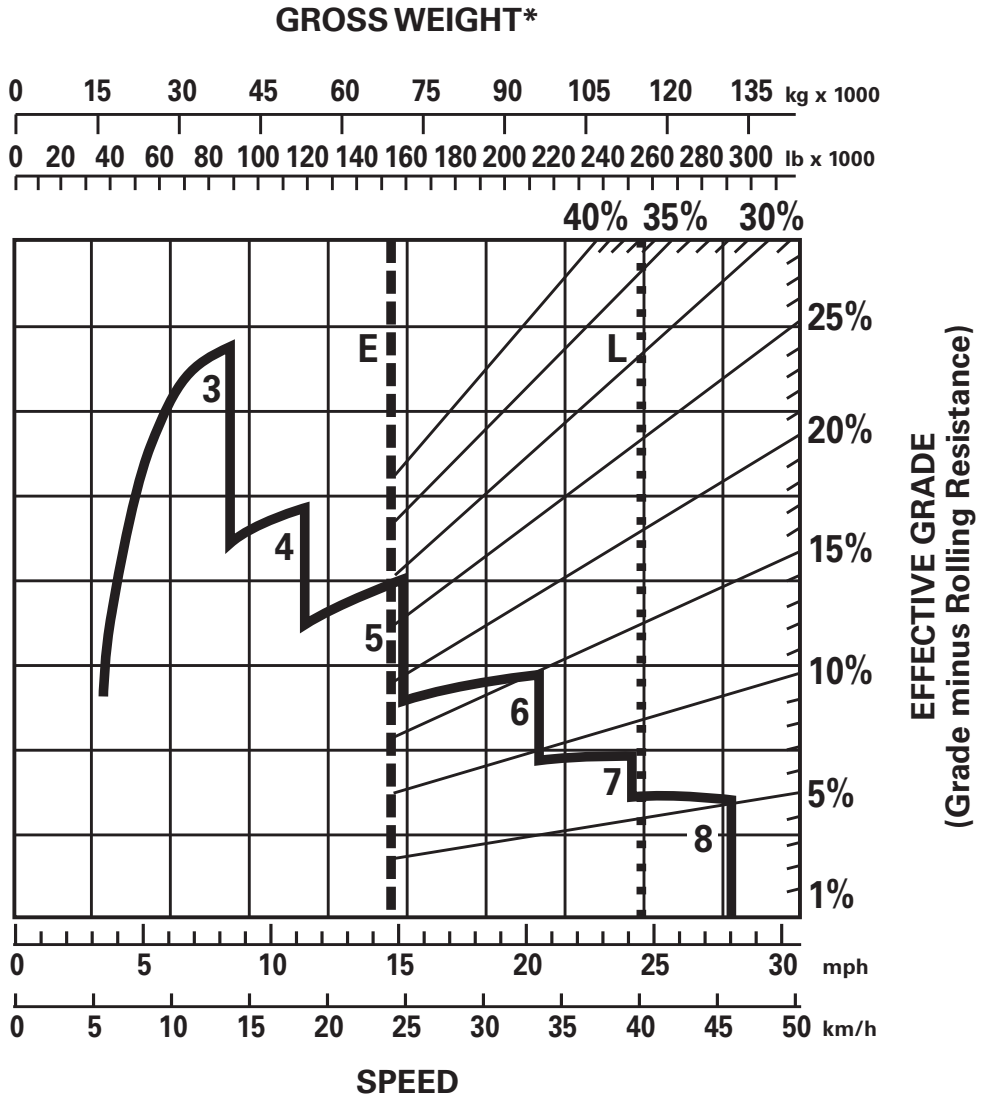

\*at sea level

**KEY**

- 3 — 3rd Gear Direct Drive
- 4 — 4th Gear Direct Drive
- 5 — 5th Gear Direct Drive
- 6 — 6th Gear Direct Drive
- 7 — 7th Gear Direct Drive
- 8 — 8th Gear Direct Drive

**KEY**

- E — Empty 72 804 kg (160,505 lb)
- L — Loaded 119 978 kg (264,505 lb)

# ESTIMATING OWNING & OPERATING COSTS

## Owning & Operating (O&O) Baseline Cost Estimate Solutions

The O&O web site provides information related to O&O baseline cost estimate development for both commercial engine products and machines. Approved O&O baseline cost estimate ranges for machines, and links related to O&O baseline cost development are also available. **NOTE:** Access to the web sites indicated below is restricted to Caterpillar and Cat® dealer personnel.

For information about O&O costs, enter the appropriate link.

**For Corporate Global Mining (CGM):** <https://mining.cat.com>  
Select "Support," "Equipment Management," "MARCs," "BUILDER Downloads."

**For North American Commercial Division (NACD):** <https://dealer.cat.com>  
Select "Product Support," "Equipment Management Solutions,"  
"Owning and Operating Cost Information."

## CONTENTS

Estimating Form . . . . .	25-2
Explanation of Form:	
Estimating Owning Costs . . . . .	25-5
Typical Application Descriptions . . . . .	25-5
① Delivered Price to the Customer . . . . .	25-6
② Residual Value at Replacement . . . . .	25-6
③ Value to be Recovered through Work . . . . .	25-7
④ Interest . . . . .	25-7
⑤ Insurance . . . . .	25-7
⑥ Taxes . . . . .	25-7
⑧ Fuel Consumption, Fuel Tables . . . . .	25-8
⑨ Planned Maintenance Costs . . . . .	25-41
⑩a Tires:	
Tire Life Estimator Curves . . . . .	25-42
Goodyear Life Estimating System . . . . .	25-45
⑩b Undercarriage . . . . .	25-46
⑪ Repair Costs . . . . .	25-48
⑫ Special Wear Items . . . . .	25-50
⑬ Operator's Hourly Wage . . . . .	25-50
O&O Cost Examples	
Example I: Track-Type Tractor . . . . .	25-50
Example II: Wheel Loader . . . . .	25-52
O&O Form with Example Figures . . . . .	25-53

## General

Machine users must balance productivity and costs to achieve optimum performance ... that is, achieve the desired production at the lowest possible cost. The approach most often used to measure machine performance is this simple equation:

$$\frac{\text{Lowest Possible Hourly Costs}}{\text{Highest Possible Hourly Productivity}} = \frac{\text{Top Machine Performance}}{\text{Performance}}$$

Most sections of this Handbook deal with the productivity of Cat machines. This section considers the cost aspect of performance.

Hourly Owning and Operating Costs for a given machine can vary widely because they are influenced by many factors: the type of work the machine does, the ownership period, local prices of fuel and labor, the repair and maintenance costs, shipping costs from the factory, interest rates, etc. No attempt is made in this handbook to provide precise hourly costs for each model. Users must be able to estimate with a reasonable degree of accuracy what a machine will cost per hour to own and operate in a given application and locality. Therefore, this section provides a suggested method of estimating hourly owning and operating costs. When this method is coupled with local conditions and dealer input, it will result in reasonable estimates.

The method suggested follows several basic principles:

- Repair and Planned Maintenance cost per hour are developed jointly by the customer and local Cat dealer.
- In the examples, labor is assumed @ \$60.00 per hour, fuel @ \$1.25 per gallon. For reliable estimates, these costs must always be obtained locally.
- Because of different standards of comparison, what may seem a high application to one machine owner may appear only medium to another.
- Unless otherwise specified, the word "hour" when used in this section means clock or operating hours, not Service Meter Units.

**NOTE:** An Excel O&O Estimating Form is available, in electronic spreadsheet format, to calculate an Hourly Owning & Operating Cost Estimate based on the procedure outlined in this section. The spreadsheet may be accessed via the website at <https://dealer.cat.com> – From the home page, select “Product Support,” “Equipment Management Solutions,” “Owning & Operating Costs.” Under the heading “Machine Technical Information,” select “O&O COST ESTIMATING Form.”

**HOURLY OWNING AND OPERATING COST ESTIMATE**

DATE \_\_\_\_\_

Estimate #1                      Estimate #2

A–Machine Designation . . . . . \_\_\_\_\_

B–Estimated Ownership Period (Years) . . . . . \_\_\_\_\_

C–Estimated Usage (Hours/Year) . . . . . \_\_\_\_\_

D–Ownership Usage (Total Hours)(B × C) . . . . . \_\_\_\_\_

**OWNING COSTS**

1. a. Delivered Price (P), to the Customer (including attachments) \_\_\_\_\_

    b. Less Tire Replacement Cost if desired . . . . . \_\_\_\_\_

    c. Delivered Price Less Tires. . . . . \_\_\_\_\_

2. Less Residual Value at Replacement (S) . . . . . (\_\_\_\_%) \_\_\_\_\_ (\_\_\_\_%) \_\_\_\_\_  
 (See subsection 2A on back)

3. a. Net Value to be recovered through work . . . . . \_\_\_\_\_  
 (line 1c less line 2)

b. Cost Per Hour:  

$$\frac{\text{Net Value}}{\text{Total Hours}} \quad (1) \quad \text{_____} \quad (2) \quad \text{_____} \quad \text{_____}$$

4. Interest Costs  $\frac{P(N + 1) + S(N - 1)}{2N} \times \text{Simple Int. \% Rate}$   
 N = No. Yrs. \_\_\_\_\_ Hours/Year = \_\_\_\_\_  
 (1)  $\frac{+1}{+1} + \frac{-1}{-1} \times \text{____ \%}$  (2)  $\frac{+1}{+1} + \frac{-1}{-1} \times \text{____ \%}$   
 \_\_\_\_\_ Hours/Yr. = \_\_\_\_\_ Hours/Yr. = \_\_\_\_\_

5. Insurance  $\frac{P(N + 1) + S(N - 1)}{2N} \times \text{Insurance \% Rate}$   
 N = No. Yrs. \_\_\_\_\_ Hours/Year = \_\_\_\_\_  
 (1)  $\frac{+1}{+1} + \frac{-1}{-1} \times \text{____ \%}$  (2)  $\frac{+1}{+1} + \frac{-1}{-1} \times \text{____ \%}$   
 \_\_\_\_\_ Hours/Yr. = \_\_\_\_\_ Hours/Yr. = \_\_\_\_\_

(Optional method when Insurance cost per year is known)

Ins. \$ \_\_\_\_\_ Per Yr. ÷ \_\_\_\_\_ Hours/Yr. = \_\_\_\_\_

Estimate #1

Estimate #2

6. Property Tax  $\frac{P(N + 1) + S(N - 1)}{2N} \times \text{Tax Rate \%}$   
 N = No. Yrs. \_\_\_\_\_ =  
 Hours/Year

(1)  $\frac{+1}{\text{Hours/Yr.}} + \frac{-1}{\text{Hours/Yr.}} \times \text{\%}$  (2)  $\frac{+1}{\text{Hours/Yr.}} + \frac{-1}{\text{Hours/Yr.}} \times \text{\%}$   
 \_\_\_\_\_ = \_\_\_\_\_ =

(Optional method when Property Tax cost per year is known)

Property Tax \$ \_\_\_\_\_ Per Yr.  $\div$  \_\_\_\_\_ Hours/Yr. =

7. TOTAL HOURLY OWNING COST  
 (add lines 3b, 4, 5 and 6) . . . . .



**OPERATING COSTS**

8. Fuel: Unit Price  $\times$  Consumption  
 (1) \_\_\_\_\_  $\times$  \_\_\_\_\_ =  
 (2) \_\_\_\_\_  $\times$  \_\_\_\_\_ =

9. Planned Maintenance (PM)-Lube Oils, Filters, Grease, Labor:  
 (contact your local Cat dealer). . . . .



10. a. Tires: Replacement Cost  $\div$  Life in Hours  
 $\frac{\text{Cost}}{\text{Life}}$  (1) \_\_\_\_\_ (2) \_\_\_\_\_ . . . . .



b. Undercarriage  
 (Impact + Abrasiveness + Z Factor)  $\times$  Basic Factor  
 (1) ( \_\_\_\_\_ + \_\_\_\_\_ + \_\_\_\_\_ ) = \_\_\_\_\_  $\times$  \_\_\_\_\_ =  
 (2) ( \_\_\_\_\_ + \_\_\_\_\_ + \_\_\_\_\_ ) =  $\frac{\text{_____}}{\text{(Total)}} \times \frac{\text{_____}}{\text{(Factor)}} =$



11. Repair Cost (Per Hour)  
 (contact your local Cat dealer). . . . .



12. Special Wear Items: Cost  $\div$  Life . . . . .  
 (See subsection 12A on back)



13. TOTAL OPERATING COSTS  
 (add lines 8, 9, 10a (or 10b), 11 and 12). . . . .



14. MACHINE OWNING PLUS OPERATING  
 (add lines 7 and 13) . . . . .



15. OPERATOR'S HOURLY WAGE (include fringes) . . . . .



16. TOTAL OWNING AND OPERATING COST . . . . .

**SUBSECTION 2A: Residual Value at Replacement**

Gross Selling Price	(est. #1) (___%)	_____	(est. #2) (___%)	_____
Less: a. Commission		_____		_____
b. Make-ready costs		_____		_____
c. Inflation during ownership period*		_____		_____
Net Residual Value		_____	(___%)	_____ (___%) of original
(Enter on line 2)				delivered price

\*When used equipment auction prices are used to estimate residual value, the effect of inflation during the ownership period should be removed to show in constant value what part of the asset must be recovered through work.

**SUBSECTION 12A: Special Items  
(cutting edges, ground engaging tools, bucket teeth, etc.)**

(1)	Cost	Life	Cost/Hour	(2)
1.	_____ ÷ _____	= _____	1.	_____ ÷ _____ = _____
2.	_____ ÷ _____	= _____	2.	_____ ÷ _____ = _____
3.	_____ ÷ _____	= _____	3.	_____ ÷ _____ = _____
4.	_____ ÷ _____	= _____	4.	_____ ÷ _____ = _____
5.	_____ ÷ _____	= _____	5.	_____ ÷ _____ = _____
6.	_____ ÷ _____	= _____	6.	_____ ÷ _____ = _____
	Total	(1) _____	(2) _____	

(Enter total on line 12)

1-7

**ESTIMATING OWNING COSTS***(Line Items 1 through 7)*

To protect their equipment investment and be able to replace it, the machine owner must recover over the ownership period an amount equal to the loss in resale value plus the other costs of owning the equipment including interest, insurance and taxes.

The machine owner, for accounting purposes, estimates resale value loss in advance, and recovers his original equipment investment by establishing depreciation schedules according to the various uses of the equipment. Proper financial and tax assistance is highly recommended when establishing depreciation schedules.

Considering today's economic conditions worldwide and the trend toward larger, more expensive equipment, many users choose to keep these units on the job well after they have been fully depreciated for tax purposes. On the other hand, tax incentives in many areas may favor trading a machine well before that occurs.

The ownership period in years, the hours per year, and the total number of hours on a machine, are significant factors in determining O&O costs. Additionally, since the ownership period and machine hours can vary widely for different customers for a given model, it is not practical to calculate O&O costs using an assumed ownership period. The customer must provide that information for each situation.

These same factors will be used to develop the Repair costs and Planned Maintenance costs by your local Cat dealer.

**The machine depreciation method suggested in this handbook is not based on or related to any tax considerations, but rather is a simple straight line write-off based solely on the number of years and hours the owner expects to use during the ownership period.**

**Accordingly, it is imperative that careful consideration be given the selection of depreciation periods, and that for owning and operating cost calculations they be based on actual ownership periods and hours on the machine rather than tax write-off life.**

**Typical Application Descriptions**

The following tables show typical descriptions for work performed by each product family for three different application levels. It is only a guide and can be used along with the fuel and tire charts to help determine fuel and tire cost factors. Additionally, many times the ownership period and the number of hours per year a machine is used, is related to application.

25

- ① Delivered Price To Customer
- ② Residual Value at Replacement

1

### DELIVERED PRICE TO CUSTOMER

*(Line Item 1a, b and c)*

Delivered price should include all costs of putting a machine on the user's job including transportation and any applicable sales taxes.

On rubber tired machines, tires are considered a wear item and covered as an operating expense. Accordingly, some users may wish to deduct tire costs from the delivered price particularly for larger machines.

2

### RESIDUAL VALUE AT REPLACEMENT

*(Line Item 2 and Subsection 2A)*

Any piece of earthmoving machinery will have some residual value at trade-in. While many owners prefer to depreciate their equipment to zero value, others recognize the residual resale or trade-in value. This is at the estimator's option, but as in the discussion of depreciation, today's higher equipment costs almost dictate that resale value be considered in determining the net depreciable investment. And if machines are traded early for tax incentive purposes, resale value becomes even more significant.

For many owners, potential resale or trade-in value is a key factor in their purchasing decisions, since this is a means of reducing the investment they must recover through depreciation charges. The high resale value of Caterpillar built machines can reduce hourly depreciation charges, lower total hourly owning costs and improve the owner's competitive position.

When resale or trade-in value is used in estimating hourly owning and operating costs, local conditions must be considered, as used equipment values vary widely around the world. However, in any given used equipment business, factors which have greatest influence on resale or trade-in value are: age of machine (years), the number of hours on the machine at the time of sale or trade, the type of jobs and operating conditions in which it worked, and the physical condition of the machine. Your local Cat dealer is your best source for determining current used equipment values.

Subsection 2A can be used to calculate the estimated residual value. If recent auction prices for used machines are used as a guide, then the value (or percentage) should be adjusted downward to remove the effect of inflation. Governmental indices on construction equipment costs or Dealer price records can be used to calculate the amount of inflation for the appropriate useful life. Another way to estimate residual value is comparing the current used machine value to the current new machine price provided major product changes haven't occurred.

③ Value to be Recovered Through Work

④ Interest

⑤ Insurance

⑥ Taxes

Owning & Operating Costs

3

**VALUE TO BE RECOVERED THROUGH WORK**

(Line Item 3a and b)

The delivered price (P) less the estimated residual value (S) results in the value to be recovered through work, divided by the total usage hours, gives the hourly cost to protect the asset's value.

4

**INTEREST**

(Line Item 4)

Many owners charge interest as part of hourly owning and operating costs, others consider it as general overhead in their overall operation. When charged to specific machines, interest is usually based on the owner's average annual investment in the unit.

Interest is considered to be the cost of using capital. The interest on capital used to purchase a machine must be considered, whether the machine is purchased outright or financed.

If the machine will be used for N years (where N is the number of years of use), calculate the average annual investment during the use period and apply the interest rate and expected annual usage:

$$\frac{\left[ \frac{P(N + 1) + S(N - 1)}{2N} \right] \times \text{Simple Int. \% Rate}}{\text{Hours/Year}}$$

5-6

**INSURANCE AND TAXES**

(Line Items 5 and 6)

Insurance cost and property taxes can be calculated in one of two ways. If the specific annual cost is known, this figure should be divided by the estimated usage (hours/years) and used. However, when the specific interest and tax costs for each machine are not known, the following formulas can be applied:

$$\frac{\text{Insurance}}{N = \text{No. Years}}$$

$$\frac{\left[ \frac{P(N + 1) + S(N - 1)}{2N} \right] \times \text{Insurance \% Rate}}{\text{Hours/Year}}$$

$$\frac{\text{Property Tax}}{N = \text{No. Years}}$$

$$\frac{\left[ \frac{P(N + 1) + S(N - 1)}{2N} \right] \times \text{Tax Rate \%}}{\text{Hours/Year}}$$



8-13

**ESTIMATING OPERATING COSTS***(Line Items 8 through 13)*

8

**FUEL CONSUMPTION***(Line Item 8)*

Actual fuel consumption should be measured in the field. However, if no opportunity exists to do this, consumption can be estimated when the machine application is known.

Application determines engine load factor and engine fuel consumption. Engine load factor refers to the instantaneous loading of the engine relative to its maximum capability. An engine continuously producing full rated horsepower is operating at a load factor of 100%. Earthmoving machines may reach a 100% load factor intermittently, but seldom operate at this level for extended periods of time. Periods spent at idle, dozer and pusher travel in reverse, haul units traveling empty, close maneuvering at part throttle and operating downhill are examples of conditions which reduce load factor.

The following tables provide hourly fuel consumption estimates at various load factors. Engine load factors are to be used as a general guide and will vary by model and application. Since machine uses vary, application guides are also provided to aid in estimating load factor.

To estimate hourly fuel cost, select the load factor based on application and find hourly consumption. Then:

$$\text{Hourly consumption} \times \text{Local Unit Price of Fuel} = \text{Hourly Fuel Cost}$$

**When using these tables, keep in mind the many variables which can affect fuel consumption. Two operators of different temperament or attitude operating identical machines side by side in the same material can have as much as 10-12% difference in their consumption rates. Actual results may vary from the ranges shown because they are created to cover a wide spectrum of operating conditions. Your Cat dealer representative can help select the most reasonable estimate for your specific situation; we suggest you call on him.**

**Keep in mind also that a fuel consumption study measured over a short period of operation will give higher fuel consumption than shown here because: (1) the study will be at 100% productivity, without breaks or idle time, and (2) the operators will know they're being measured and therefore may not use their normal operating techniques. On the other hand, these tables allow for "normal" inefficiencies in the working cycle and will more closely relate to "normal" day to day operation.**

FUEL CONSUMPTION TABLES AND LOAD FACTOR GUIDES

TRACK-TYPE TRACTORS

Model	Low		Medium		High	
	liter	U.S. gal	liter	U.S. gal	liter	U.S. gal
D3K2 <sup>3</sup>	7.6	2.0	8.7	2.3	15.5	4.1
D4K2 <sup>3</sup>	8.3	2.2	9.5	2.5	15.9	4.2
D5K2 <sup>3</sup>	8.7	2.3	9.9	2.6	16.7	4.4
D3K2 <sup>1</sup>	6.8	1.8	7.6	2.0	15.2	4.0
D4K2 <sup>1</sup>	7.6	2.0	8.3	2.2	15.5	4.1
D5K2 <sup>1</sup>	8.0	2.1	8.7	2.3	15.9	4.2
D6K2 <sup>3</sup>	9.1-12.0	2.4-3.2	12.0-16.6	3.2-4.4	16.6-22.9	4.4-6.1
D6K2 <sup>1</sup>	7.9-10.4	2.1-2.7	10.4-14.4	2.7-3.8	14.4-19.8	3.8-5.2
D5R2 <sup>3</sup>	11.7-14.6	3.1-3.9	14.6-19.4	3.9-5.1	19.4-25.6	5.1-6.8
D6N <sup>1</sup>	8.9-12.0	2.4-3.2	12.0-15.8	3.2-4.2	15.8-22.4	4.2-5.9
D6R (130 kW/175 hp)	13.2-18.9	3.5-5.0	18.9-24.6	5.0-6.5	24.6-30.3	6.5-8.0
D6R (145 kW/195 hp)	14.8-21.2	3.9-5.6	21.2-27.3	5.6-7.2	27.3-33.7	7.2-8.9
D6T (138 kW/185 hp)	15.5-22.3	4.1-5.9	22.3-28.8	5.9-7.6	28.8-35.6	7.6-9.4
D6T <sup>1</sup>	15.0-21.3	4.0-5.6	21.3-27.7	5.6-7.3	27.7-34.0	7.3-9.0
D7E <sup>1</sup>	13.6-19.3	3.6-5.1	19.3-25.2	5.1-6.7	25.2-31.8	6.7-8.4
D7R	17.8-24.4	4.7-6.5	24.4-31.0	6.5-8.2	31.0-37.6	8.2-9.9
D8R	22.5-32.0	6.0-8.5	32.0-41.5	8.5-11.0	41.5-51.0	11.0-13.5
D8T <sup>3</sup>	23.5-33.7	6.2-8.9	33.7-43.5	8.9-11.5	43.9-53.7	11.6-14.2
D8T <sup>1</sup>	23.7-34.3	6.3-9.1	34.3-44.2	9.1-11.7	44.1-54.2	11.7-14.3
D9T <sup>3</sup>	30.3-43.1	8.0-11.4	43.1-56.4	11.4-14.9	56.4-69.3	14.9-18.3
D9T <sup>4</sup>	28.2-40.1	7.4-10.6	40.1-52.5	10.6-13.9	52.5-64.4	13.9-17.0
D9T <sup>1</sup>	31.2-44.4	8.2-11.7	44.4-58.1	11.7-15.3	58.1-71.4	15.3-18.9
D10T2 <sup>6</sup>	39.5-56.3	10.4-14.9	56.3-73.3	14.9-19.4	73.3-90.2	19.4-23.9
D10T2 <sup>5</sup>	43.0-61.3	11.4-16.3	61.3-79.8	16.3-21.1	79.8-98.2	21.1-26.0
D11T <sup>6</sup>	59.6-85.2	15.8-22.5	85.2-110.7	22.5-29.3	110.7-136.3	29.3-36.0
D11T <sup>5</sup>	60.3-86.1	15.9-22.8	86.1-112.0	22.8-29.6	112.0-137.8	29.6-36.4

<sup>1</sup> Meets U.S. EPA Tier 4 Final/EU Stage IV/Japan 2014 (Tier 4 Final) emission standards — Calculations include DEF

<sup>2</sup> Meets Tier 4 Interim/Stage IIIB/Japan 2011 (Tier 4 Interim) equivalent emission standards.

<sup>3</sup> Meets Tier 3/Stage IIIA/Japan 2006 (Tier 3) equivalent emission standards.

<sup>4</sup> Meets Tier 2/Stage II/Japan 2001(Tier 2) equivalent emission standards.

<sup>5</sup> Meets Tier 4 Final emission standards.

<sup>6</sup> Meets Tier 2 equivalent emission standards.

**Typical Application Description**

(relative to work application)

**Low** Pulling scrapers, most agricultural drawbar, stockpile, coal pile and finish grade applications. No impact. Intermittent full throttle operation.

**Medium** Production dozing in clays, sands, gravels. Push loading scrapers, borrow pit ripping, most land clearing applications. Medium impact conditions. Production landfill work.

**High** Heavy rock ripping. Push loading and dozing in hard rock. Working on rock surfaces. Continuous high impact conditions.

**Load Factor Guide**

(average engine load factor based on application description for each range)

**Low** 35%-50%

**Medium** 50%-65%

**High** 65%-80%

**Product Link™ Information** — Product link measured over hundreds of Track-Type Tractors shows that more than 90% of the machines experience an average fuel consumption equal to or lower than those shown in the Medium Application profile.

- Pipelayers
- Motor Graders

### PIPELAYERS

Model	Low		Medium		High	
	liter	U.S. gal	liter	U.S. gal	liter	U.S. gal
PL61	5.7-11.7	1.5-3.0	9.7-15.1	2.5-4.0	13.2-18.9	3.5-5.0
PL83	11.8-16.9	3.1-4.5	16.9-21.8	4.5-5.8	21.8-26.8	5.8-7.1
PL87	15.3-21.9	4.0-5.8	21.9-28.3	5.8-7.5	28.3-34.9	7.5-9.2
572R Series 2	8.5-12.3	2.2-3.3	12.3-15.7	3.3-4.2	15.7-19.5	4.2-5.2

#### Typical Application Description

(relative to work application)

Low Little or no use in mud, water or on rock. Use on level, regular surfaces.

Medium Typical pipelayer use in operating conditions ranging from very good to severe.

High Continuous use in deep mud or water or on rock surfaces.

#### Load Factor Guide

(average engine load factor based on application description for each range)

Low 35%-50%

Medium 50%-65%

High 65%-80%

### MOTOR GRADERS

Model	Low		Medium		High	
	liter	U.S. gal	liter	U.S. gal	liter	U.S. gal
120K <sup>1</sup>	7.2-8.9	1.9-2.4	8.9-14.9	2.4-3.9	14.9-20.9	3.9-5.5
120K2 <sup>2</sup>	7.5-9.4	2.0-2.5	9.4-15.6	2.5-4.1	15.6-21.9	4.1-5.8
120M <sup>2</sup>	6.3-7.9	1.7-2.1	7.9-13.1	2.1-3.5	13.1-18.4	3.5-4.9
120M AWD <sup>2</sup>	7.8-9.8	2.1-2.6	9.8-16.3	2.6-4.3	16.3-22.8	4.3-6.0
12K <sup>1</sup>	8.9-11.1	2.3-2.9	11.1-18.5	2.9-4.9	18.5-25.8	4.9-6.8
12M <sup>2</sup>	6.9-8.7	1.8-2.3	8.7-14.4	2.3-3.8	14.4-20.2	3.8-5.3
12M (B92) <sup>2</sup>	9.3-11.6	2.5-3.1	11.6-19.3	3.1-5.1	19.3-27.0	5.1-7.1
140K <sup>1</sup>	9.3-11.6	2.5-3.1	11.6-19.4	3.1-5.1	19.4-27.2	5.1-7.2
140K2 <sup>2</sup>	9.4-11.8	2.5-3.1	11.8-19.6	3.1-5.2	19.6-27.5	5.2-7.3
140M2	9.7-12.1	2.6-3.2	12.1-20.1	3.2-5.3	20.1-28.2	5.3-7.4
140M AWD <sup>2</sup>	11.9-14.9	3.1-3.9	14.9-24.8	3.9-6.6	24.8-34.7	6.6-9.2
160K <sup>1</sup>	9.7-12.1	2.6-3.2	12.1-20.1	3.2-5.3	20.1-28.2	5.3-7.4
160M <sup>2</sup>	10.2-12.7	2.7-3.4	12.7-21.2	3.4-5.6	21.2-29.7	5.6-7.8
160M AWD <sup>2</sup>	11.9-14.9	3.2-3.9	14.9-24.8	3.9-6.6	24.8-34.8	6.6-9.2

<sup>1</sup> Meets Tier 2/Stage II equivalent emission standards.

<sup>2</sup> Meets Tier 3/Stage IIIA equivalent emission standards.

**NOTE:** The Motor Grader fuel rates are taken directly from our customer machines registered on Product Link worldwide. Fuel consumption varies depending upon geographical region, emission level, weight, application, fuel quality and other factors. Long term, most machines (approximately 90%) will see fuel consumption equal to or lower than the Medium Range. These values are subject to change. Consult your local dealer for ways to more accurately estimate hourly fuel consumption for specific applications. Newly released machines are based on developmental field data.

**MOTOR GRADERS**

Model	Low		Medium		High	
	liter	U.S. gal	liter	U.S. gal	liter	U.S. gal
14M <sup>3</sup>	10.1-12.6	<b>2.7-3.3</b>	12.6-21.1	<b>3.3-5.6</b>	21.1-29.5	<b>5.6-7.8</b>
16M <sup>3</sup>	13.3-16.6	<b>3.5-4.4</b>	16.6-27.7	<b>4.4-7.3</b>	27.7-38.7	<b>7.3-10.2</b>
24M (B9K) <sup>1</sup>	25.0-31.2	<b>6.6-8.3</b>	31.2-52.0	<b>8.3-13.8</b>	52.0-72.9	<b>13.8-19.3</b>
24M (B9K) <sup>3</sup>	27.3-34.1	<b>7.2-9.0</b>	34.1-56.8	<b>9.0-15.0</b>	56.8-79.5	<b>15.0-21.0</b>
24M (B93) <sup>2</sup>	26.1-32.6	<b>6.9-8.6</b>	32.6-54.4	<b>8.6-14.4</b>	54.4-76.2	<b>14.4-20.1</b>
24M (B93) <sup>3</sup>	26.7-33.4	<b>7.1-8.8</b>	33.4-55.6	<b>8.8-14.7</b>	55.6-77.8	<b>14.7-20.6</b>
120M2 <sup>4</sup>	7.2-9.0	<b>1.9-2.4</b>	9.0-15.0	<b>2.4-4.0</b>	15.0-21.0	<b>4.0-5.5</b>
120M2 AWD <sup>4</sup>	8.2-10.2	<b>2.2-2.7</b>	10.2-17.1	<b>2.7-4.5</b>	17.1-23.9	<b>4.5-6.3</b>
12M2 <sup>4</sup>	8.6-10.8	<b>2.3-2.9</b>	10.8-18.0	<b>2.9-4.8</b>	18.0-25.2	<b>4.8-6.7</b>
12M2 AWD <sup>4</sup>	10.2-12.8	<b>2.7-3.4</b>	12.8-21.3	<b>3.4-5.6</b>	21.3-29.8	<b>5.6-7.9</b>
140M2 <sup>4</sup>	9.1-11.4	<b>2.4-3.0</b>	11.4-18.9	<b>3.0-5.0</b>	18.9-26.5	<b>5.0-7.0</b>
140M2 AWD <sup>4</sup>	10.7-13.4	<b>2.8-3.5</b>	13.4-22.3	<b>3.5-5.9</b>	22.3-31.2	<b>5.9-8.2</b>
160M2 <sup>4</sup>	10.4-13.0	<b>2.7-3.4</b>	13.0-21.7	<b>3.4-5.7</b>	21.7-30.3	<b>5.7-8.0</b>
160M2 AWD <sup>4</sup>	11.1-13.9	<b>2.9-3.7</b>	13.9-23.2	<b>3.7-6.1</b>	23.2-32.5	<b>6.1-8.6</b>
12M3 <sup>5</sup>	8.4-10.5	<b>2.2-2.8</b>	10.5-17.5	<b>2.8-4.6</b>	17.5-24.5	<b>4.6-6.5</b>
12M3 AWD <sup>5</sup>	9.7-12.1	<b>2.6-3.2</b>	12.1-20.1	<b>3.2-5.3</b>	20.1-28.2	<b>5.3-7.4</b>
140M3 <sup>5</sup>	8.9-11.1	<b>2.3-2.9</b>	11.1-18.5	<b>2.9-4.9</b>	18.5-25.8	<b>4.9-6.8</b>
140M3 AWD <sup>5</sup>	10.0-12.5	<b>2.6-3.3</b>	12.5-20.8	<b>3.3-5.5</b>	20.8-29.1	<b>5.5-7.7</b>
160M3 <sup>5</sup>	10.1-12.6	<b>2.7-3.3</b>	12.6-21.1	<b>3.3-5.6</b>	21.1-29.5	<b>5.6-7.8</b>
160M3 AWD <sup>5</sup>	10.8-13.5	<b>2.9-3.6</b>	13.5-22.5	<b>3.6-5.9</b>	22.5-31.5	<b>5.9-8.3</b>
14M3 <sup>2</sup>	10.0-12.5	<b>2.6-3.3</b>	12.5-20.9	<b>3.3-5.5</b>	20.9-29.2	<b>5.5-7.7</b>
14M3 <sup>3</sup>	10.7-13.4	<b>2.8-3.5</b>	13.4-22.4	<b>3.5-5.9</b>	22.4-31.3	<b>5.9-8.3</b>
14M3 <sup>5</sup>	11.5-14.3	<b>3.0-3.8</b>	14.3-23.9	<b>3.8-6.3</b>	23.9-33.4	<b>6.3-8.8</b>
16M3 <sup>2</sup>	12.5-15.6	<b>3.3-4.1</b>	15.6-26.0	<b>4.1-6.9</b>	26.0-36.4	<b>6.9-9.6</b>
16M3 <sup>3</sup>	13.3-16.6	<b>3.5-4.4</b>	16.6-27.7	<b>4.4-7.3</b>	27.7-38.7	<b>7.3-10.2</b>
16M3 <sup>5</sup>	14.1-17.6	<b>3.7-4.7</b>	17.6-29.3	<b>4.7-7.8</b>	29.3-41.1	<b>7.8-10.9</b>
18M3 <sup>2</sup>	12.7-15.9	<b>3.4-4.2</b>	15.9-26.5	<b>4.2-7.0</b>	26.5-37.2	<b>7.0-9.8</b>
18M3 <sup>3</sup>	13.6-16.9	<b>3.6-4.5</b>	16.9-28.2	<b>4.5-7.5</b>	28.2-39.5	<b>7.5-10.4</b>
18M3 <sup>5</sup>	14.4-18.0	<b>3.8-4.7</b>	18.0-29.9	<b>4.7-7.9</b>	29.9-41.9	<b>7.9-11.1</b>

<sup>1</sup> Does not meet any emission standards.

<sup>2</sup> Meets Tier 2/Stage II equivalent emission standards.

<sup>3</sup> Meets Tier 3/Stage IIIA equivalent emission standards.

<sup>4</sup> Meets Tier 4 Interim/Stage IIIB equivalent emission standards.

<sup>5</sup> Meets Tier 4 Final/Stage IV emission standards. Machine requires the use of Diesel Exhaust Fluid (DEF) with consumption rate of approximately 2-3% of diesel fuel.

**NOTE:** The Motor Grader fuel rates are taken directly from our customer machines registered on Product Link worldwide. Fuel consumption varies depending upon geographical region, emission level, weight, application, fuel quality and other factors. Long term, most machines (approximately 90%) will see fuel consumption equal to or lower than the Medium Range. These values are subject to change. Consult your local dealer for ways to more accurately estimate hourly fuel consumption for specific applications. Newly released machines are based on developmental field data.

**Motor Graders**

**Typical Application Description**

(relative to work application)

- Low Light road maintenance. Finish grading. Plant and road mix work. Extended idle.
- Medium Haul road maintenance. Average road maintenance, road mix work, scarifying. Road construction, ditching, loose fill spreading. Land forming, land leveling and elevating grader use. Light to medium snow removal. Lower speed travel on slight grades.
- High Heavy maintenance of hard packed roads with embedded rock. Heavy fill spreading, base material spreading and ditching. Ripping/scarifying of asphalt or concrete. Continuous high load factor. High impact. Heavy snow plowing. High speed travel on grades.

**Load Factor Guide**

(average engine load factor based on Product Status Report for description for each range)

- Low 20%-30%
- Medium 30%-50%
- High 50%-80%

⑧ Hourly Fuel Consumption Tables  
 ● Skid Steer Loaders, Multi Terrain Loaders  
 and Compact Track Loaders

Owning & Operating Costs

**SKID STEER LOADERS, MULTI TERRAIN LOADERS AND COMPACT TRACK LOADERS**

Model	Low		Medium		High	
	liter	U.S. gal	liter	U.S. gal	liter	U.S. gal
226D <sup>1</sup>	5.0-7.2	1.3-1.9	7.2-9.3	1.9-2.5	9.3-11.4	2.5-3.0
232D <sup>1</sup>	5.0-7.2	1.3-1.9	7.2-9.3	1.9-2.5	9.3-11.4	2.5-3.0
236D <sup>1</sup>	5.3-7.6	1.4-2.0	7.6-9.9	2.0-2.6	9.9-12.1	2.6-3.2
239D <sup>1</sup>	5.0-7.2	1.3-1.9	7.2-9.3	1.9-2.5	9.3-11.4	2.5-3.0
242D <sup>1</sup>	5.3-7.6	1.4-2.0	7.6-9.9	2.0-2.6	9.9-12.1	2.6-3.2
246D <sup>1</sup>	5.3-7.6	1.4-2.0	7.6-9.9	2.0-2.6	9.9-12.1	2.6-3.2
249D <sup>1</sup>	5.0-7.2	1.3-1.9	7.2-9.3	1.9-2.5	9.3-11.4	2.5-3.0
257D <sup>1</sup>	5.3-7.6	1.4-2.0	7.6-9.9	2.0-2.6	9.9-12.1	2.6-3.2
259D <sup>1</sup>	5.3-7.6	1.4-2.0	7.6-9.9	2.0-2.6	9.9-12.1	2.6-3.2
262D <sup>1</sup>	5.3-7.6	1.4-2.0	7.6-9.9	2.0-2.6	9.9-12.1	2.6-3.2
277D <sup>1</sup>	5.3-7.6	1.4-2.0	7.6-9.9	2.0-2.6	9.9-12.1	2.6-3.2
279D <sup>1</sup>	5.3-7.6	1.4-2.0	7.6-9.9	2.0-2.6	9.9-12.1	2.6-3.2
287D <sup>1</sup>	5.3-7.6	1.4-2.0	7.6-9.9	2.0-2.6	9.9-12.1	2.6-3.2
289D <sup>1</sup>	5.3-7.6	1.4-2.0	7.6-9.9	2.0-2.6	9.9-12.1	2.6-3.2
272D2 <sup>2</sup>	6.7-9.6	1.8-2.5	9.6-12.5	2.5-3.3	12.5-15.4	3.3-4.1
272D2 XHP <sup>2</sup>	7.6-10.8	2.0-2.8	10.9-14.0	2.8-3.7	14.0-17.3	3.7-4.6
297D2 <sup>2</sup>	6.7-9.6	1.8-2.5	9.6-12.5	2.5-3.3	12.5-15.4	3.3-4.1
297D2 XHP <sup>2</sup>	7.6-10.8	2.0-2.8	10.9-14.0	2.8-3.7	14.0-17.3	3.7-4.6
299D2 <sup>2</sup>	6.7-9.6	1.8-2.5	9.6-12.5	2.5-3.3	12.5-15.4	3.3-4.1
299D2 XHP <sup>2</sup>	7.6-10.8	2.0-2.8	10.9-14.0	2.8-3.7	14.0-17.3	3.7-4.6
216B3 <sup>3</sup>	3.98-5.69	1.05-1.50	5.69-7.40	1.50-1.95	7.40-9.11	1.95-2.41
226B3 <sup>3</sup>	5.89-8.42	1.56-2.22	8.42-10.94	2.22-2.89	10.94-13.47	2.89-3.56
232D <sup>3</sup>	5.2-7.4	1.4-2.0	7.4-9.6	2.0-2.5	9.6-11.8	2.5-3.1
236D <sup>3</sup>	5.7-8.2	1.5-2.2	8.1-10.6	2.2-2.8	10.6-13.1	2.8-3.5
239D <sup>3</sup>	5.2-7.4	1.4-2.0	7.4-9.6	2.0-2.5	9.6-11.8	2.5-3.1
242D <sup>3</sup>	5.7-8.2	1.5-2.2	8.2-10.7	2.2-2.8	10.7-13.1	2.8-3.5
246D <sup>3</sup>	5.7-8.2	1.5-2.2	8.2-10.7	2.2-2.8	10.7-13.1	2.8-3.5
249D <sup>3</sup>	5.2-7.4	1.4-2.0	7.4-9.6	2.0-2.5	9.6-11.8	2.5-3.1
257D <sup>3</sup>	5.7-8.2	1.5-2.2	8.2-10.7	2.2-2.8	10.7-13.1	2.8-3.5
259D <sup>3</sup>	5.7-8.2	1.5-2.2	8.2-10.7	2.2-2.8	10.7-13.1	2.8-3.5
262D <sup>3</sup>	5.7-8.2	1.5-2.2	8.2-10.7	2.2-2.8	10.7-13.1	2.8-3.5
277D <sup>3</sup>	5.7-8.2	1.5-2.2	8.2-10.7	2.2-2.8	10.7-13.1	2.8-3.5
279D <sup>3</sup>	5.7-8.2	1.5-2.2	8.2-10.7	2.2-2.8	10.7-13.1	2.8-3.5
287D <sup>3</sup>	5.7-8.2	1.5-2.2	8.2-10.7	2.2-2.8	10.7-13.1	2.8-3.5
289D <sup>3</sup>	5.7-8.2	1.5-2.2	8.2-10.7	2.2-2.8	10.7-13.1	2.8-3.5

<sup>1</sup> Meets Tier 4 Final, Stage IIIB, Japan 2011 (Tier 4 Interim) equivalent emission standards.

<sup>2</sup> Meets Tier 4 Final, Stage IV, Japan 2014 (Tier 4 Final) emission standards.

<sup>3</sup> Meets Tier 4 Interim, Stage IIIA, Japan 2006 (Tier 3) equivalent emission standards OR Tier 2, Stage II, Japan 2001 (Tier 2) equivalent emission standards.

## Owning & Operating Costs

- ⑧ Hourly Fuel Consumption Tables
- Skid Steer Loaders, Multi Terrain Loaders and Compact Track Loaders
  - Underground Mining — Hard Rock Articulated Trucks

### Skid Steer Loaders, Multi Terrain Loaders and Compact Track Loaders

#### Typical Application Description

(relative to work application)

- Low** Light utility, construction, nursery and landscaping applications. Load and carry of free flowing, low density materials on firm, smooth surfaces for short distances with minimal grades. Light snow removal.
- Medium** Industrial and construction job site applications. Loading from bank or load and carry of low to medium density materials on normal surfaces with low to medium rolling resistance and slight adverse grades. Occasional use of various attachments under normal loading conditions.
- High** Continuous industrial, construction and batch plant applications. Loading from tight banks or load and carry of high density materials on rough or very soft surfaces with high rolling resistance and adverse grades. Maximum use of high flow attachments under high loading conditions.

#### Load Factor Guide

(average engine load factor based on application description for each range)

- Low** 35%-50%
- Medium** 50%-65%
- High** 65%-80%

### UNDERGROUND MINING — Hard Rock Articulated Trucks

Model	Low		Medium		High	
	liter	U.S. gal	liter	U.S. gal	liter	U.S. gal
AD30	27.0-38.0	<b>7.1-10.0</b>	38.0-45.0	<b>10.0-11.9</b>	45.0-56.0	<b>11.9-14.8</b>
AD45B	35.0-45.0	<b>9.2-11.9</b>	45.0-55.0	<b>11.9-14.5</b>	55.0-65.0	<b>14.5-17.2</b>
AD55 Flat Haul	35.0-42.0	<b>9.2-11.1</b>	42.0-57.0	<b>11.1-15.0</b>	57.0-70.0	<b>15.0-18.5</b>
AD60	45.0-55.0	<b>11.9-14.5</b>	55.0-65.0	<b>14.5-17.2</b>	65.0-80.0	<b>17.2-21.1</b>

#### Typical Application Description

(relative to work application)

- Low** Continuous operation at <80% of maximum recommended gross weight. Short to medium haul distances: 300-1000 m (**990-3300 feet**). Well maintained, level haul roads. Considerable amount of idling. Very few tray impacts. Low load factor.
- Medium** Intermittent operation at less than maximum recommended gross weight. Medium to longer haul distances: 1000-5000 m (**3300-16,000 feet**). Varying haul road conditions with some adverse grades. Occasional tray impacts. Medium load factor.
- High** Continuous operation at maximum recommended gross weight. Long haul distances: >5000 m (**>16,000 feet**). Poor haul road conditions with adverse/steep grades. Frequent tray impacts. High load factor.

#### Load Factor Guide

(average engine load factor based on application description for each range)

- Low** 20%-40%
- Medium** 40%-60%
- High** 60%-80%

⑧ Hourly Fuel Consumption Tables  
 ● Underground Mining —  
 Hard Rock Load-Haul-Dumps (LHD's)

Owning & Operating Costs

**UNDERGROUND MINING — Hard Rock Load-Haul-Dumps (LHD's)**

Model	Low		Medium		High	
	liter	U.S. gal	liter	U.S. gal	liter	U.S. gal
R1300G	11.3-15.1	<b>3.0-4.0</b>	15.1-18.9	<b>4.0-5.0</b>	18.9-22.7	<b>5.0-6.0</b>
R1600H	15.1-22.7	<b>4.0-6.0</b>	22.7-28.3	<b>6.0-7.5</b>	28.3-39.7	<b>7.5-10.5</b>
R1700G	22.7-26.4	<b>6.0-7.0</b>	26.4-34.0	<b>7.0-9.0</b>	34.0-45.4	<b>9.0-12.0</b>
R2900G	30.2-37.8	<b>8.0-10.0</b>	37.8-45.4	<b>10.0-12.0</b>	45.4-56.7	<b>12.0-15.0</b>
R3000H	33.0-40.0	<b>8.7-10.5</b>	40.0-47.0	<b>10.5-12.4</b>	47.0-59.0	<b>12.4-15.6</b>

**Typical Application Description**

(relative to work application)

- Low Dig and carry operation from stockpiles to ground level transfer station. Low density, free flowing ore and waste. Excellent draw point floor surfaces. Short haul distances: 25-100 m (**80-330 feet**). Level roads with good surface conditions. Low load factor.
- Medium Intermittent development/production loading into trucks/transfer station. Good digging with well shot, low to medium density ore and waste. Average draw point floor surfaces. Medium haul distances: 100-200 m (**330-660 feet**). Poor road surfaces with slightly adverse grades. Medium load factor.
- High Continuous production loading of trucks at or near maximum load height. Difficult digging. Loading haul trucks. Rough draw point surfaces. Long haul distances: 200-300 m (**660-990 feet**). Poor haul roads with adverse grades. High load factor.

**Load Factor Guide**

(average engine load factor based on application description for each range)

- Low 20%-40%
- Medium 40%-60%
- High 60%-80%



**EXCAVATORS**

Model	Low		Medium		High	
	liter	U.S. gal	liter	U.S. gal	liter	U.S. gal
<b>MHE D SERIES</b>						
300.9D	0.9-1.4	<b>0.24-0.35</b>	1.4-1.8	<b>0.35-0.47</b>	1.8-2.3	<b>0.47-0.59</b>
301.7D	0.9-1.4	<b>0.24-0.35</b>	1.4-1.8	<b>0.35-0.47</b>	1.8-2.3	<b>0.47-0.59</b>
301.7D CR	0.9-1.4	<b>0.24-0.35</b>	1.4-1.8	<b>0.35-0.47</b>	1.8-2.3	<b>0.47-0.59</b>
302.4D	1.2-1.8	<b>0.31-0.47</b>	1.8-2.4	<b>0.47-0.62</b>	2.4-3.0	<b>0.62-0.78</b>
302.7D CR	1.2-1.8	<b>0.31-0.47</b>	1.8-2.4	<b>0.47-0.62</b>	2.4-3.0	<b>0.62-0.78</b>
<b>MHE E SERIES</b>						
303E CR <sup>2</sup>	1.1-2.3	<b>0.3-0.6</b>	2.3-3.4	<b>0.6-0.9</b>	3.4-4.5	<b>0.9-1.2</b>
303.5E CR <sup>1</sup>	1.4-2.8	<b>0.4-0.7</b>	2.8-4.3	<b>0.7-1.1</b>	4.3-5.7	<b>1.1-1.5</b>
303.5E2 CR <sup>2</sup>	1.1-2.2	<b>0.3-0.6</b>	2.2-3.3	<b>0.6-0.9</b>	3.3-4.4	<b>0.9-1.2</b>
304E2, 305E2 <sup>1</sup>	1.7-3.4	<b>0.4-0.9</b>	3.4-5.1	<b>0.9-1.3</b>	5.1-6.7	<b>1.3-1.8</b>
304E2 CR, 304.5E2 CR XTC <sup>2</sup>	1.7-3.4	<b>0.4-0.9</b>	3.4-5.1	<b>0.9-1.3</b>	5.1-6.8	<b>1.3-1.8</b>
305.5E2 <sup>1</sup>	1.8-3.6	<b>0.5-0.9</b>	3.6-5.3	<b>0.9-1.4</b>	5.3-7.1	<b>1.4-1.9</b>
305E2 CR <sup>2</sup>	1.7-3.4	<b>0.4-0.9</b>	3.4-5.1	<b>0.9-1.3</b>	5.1-6.8	<b>1.3-1.8</b>
305.5E2 CR <sup>2</sup>	1.7-3.4	<b>0.4-0.9</b>	3.4-5.1	<b>0.9-1.4</b>	5.1-6.8	<b>1.4-1.8</b>
307E2 <sup>2</sup>	2.2-4.4	<b>0.5-1.2</b>	4.4-6.6	<b>1.5-1.7</b>	6.6-8.7	<b>1.7-2.3</b>
308E2, 308E2 VAB <sup>2</sup>	2.7-5.4	<b>0.7-1.4</b>	5.4-8.0	<b>1.4-2.1</b>	8.0-10.7	<b>2.1-2.8</b>
306E, 307E <sup>1</sup>	2.3-4.6	<b>0.6-1.2</b>	4.6-6.8	<b>1.2-1.8</b>	6.8-9.1	<b>1.8-2.4</b>
305.5E <sup>1</sup>	2.0-4.0	<b>0.5-1.1</b>	4.0-6.0	<b>1.1-1.6</b>	6.0-8.0	<b>1.6-2.1</b>
308E <sup>1</sup>	2.9-5.7	<b>0.8-1.5</b>	5.7-8.6	<b>1.5-2.3</b>	8.6-11.5	<b>2.3-3.0</b>
<b>HEX D SERIES</b>						
311D RR <sup>3</sup> (STD C4.2 ACERT™)	3.5-6.5	<b>0.9-1.7</b>	6.5-9.5	<b>1.7-2.5</b>	9.5-12.8	<b>2.5-3.4</b>
312D <sup>3</sup> (STD C4.2 ACERT)	4.0-7.5	<b>1.1-2.0</b>	7.5-11.5	<b>2.0-3.0</b>	11.5-15.2	<b>3.0-4.0</b>
312D <sup>3</sup> (ECO C4.2 ACERT)	3.6-6.8	<b>1.0-1.8</b>	6.8-10.4	<b>1.8-2.7</b>	10.4-13.7	<b>2.7-3.6</b>
315D <sup>3</sup> (STD C4.2 ACERT)	5.0-9.5	<b>1.3-2.5</b>	9.5-14.5	<b>2.5-3.8</b>	14.5-19.2	<b>3.8-5.1</b>
315D <sup>3</sup> (ECO C4.2 ACERT)	4.5-8.6	<b>1.2-2.3</b>	8.6-13.1	<b>2.3-3.5</b>	13.1-17.3	<b>3.5-4.6</b>
319D <sup>3</sup> (STD C4.2 ACERT)	5.5-10.5	<b>1.5-2.8</b>	10.5-15.5	<b>2.8-4.1</b>	15.5-21.0	<b>4.1-5.5</b>
320D2 <sup>4</sup> (STD Panther)	5.3-13.3	<b>1.4-3.5</b>	13.3-18.6	<b>3.5-4.9</b>	18.6-26.5	<b>4.9-7.0</b>
323D2 <sup>4</sup> (HHP Unity)	5.4-13.5	<b>1.4-3.6</b>	13.5-18.9	<b>3.6-5.0</b>	18.9-27.0	<b>5.0-7.1</b>
336D <sup>3</sup> (ECO C9 ACERT)	9.5-19.1	<b>2.5-5.0</b>	19.1-28.6	<b>5.0-7.6</b>	28.6-37.8	<b>7.6-10.0</b>
336D <sup>3</sup> (STD C9 ACERT)	10.2-20.5	<b>2.7-5.4</b>	20.5-30.7	<b>5.4-8.1</b>	30.7-40.5	<b>8.1-10.7</b>
336D <sup>3</sup> (HHP C9 ACERT)	11.5-23.0	<b>3.0-6.1</b>	23.0-34.5	<b>6.1-9.1</b>	34.5-45.5	<b>9.1-12.0</b>
336D <sup>4</sup> (ECO C9 ACERT)	9.1-17.8	<b>2.4-4.7</b>	17.8-27.0	<b>4.7-7.1</b>	27.0-36.1	<b>7.1-9.5</b>
336D <sup>4</sup> (STD C9 ACERT)	9.8-19.1	<b>2.6-5.1</b>	19.1-28.9	<b>5.1-7.6</b>	28.9-38.7	<b>7.6-10.2</b>
336D <sup>4</sup> (HHP C9 ACERT)	11.0-21.5	<b>2.9-5.7</b>	21.5-32.5	<b>5.7-8.6</b>	32.5-43.5	<b>8.6-11.5</b>
345D <sup>3</sup> (C13 ACERT)	15.5-30.5	<b>4.1-8.1</b>	30.5-45.6	<b>8.1-12.0</b>	45.6-61.0	<b>12.0-16.1</b>
345D <sup>4</sup> (C13 ACERT)	14.5-29.0	<b>3.8-7.7</b>	29.0-43.3	<b>7.7-11.4</b>	43.3-58.0	<b>11.4-15.3</b>
374D <sup>3A</sup> (C15 ACERT)	28.0-46.0	<b>7.4-12.2</b>	46.0-55.0	<b>12.2-14.5</b>	55.0-68.0	<b>14.5-18.0</b>
374D <sup>4A</sup> (C15 ACERT)	26.6-43.7	<b>7.0-11.5</b>	43.7-52.3	<b>11.5-13.8</b>	52.3-64.6	<b>13.8-17.1</b>
390D <sup>3A</sup> (C18 ACERT)	31.0-52.0	<b>8.2-13.7</b>	52.0-66.5	<b>13.7-17.6</b>	66.5-77.0	<b>17.6-20.3</b>
390D <sup>4A</sup> (C18 ACERT)	29.5-49.4	<b>7.8-13.0</b>	49.4-63.2	<b>13.0-16.7</b>	63.2-73.2	<b>16.7-19.3</b>

<sup>1</sup> Meets Tier 4 Final, Stage IIIB, Japan 2011 (Tier 4 Interim) equivalent emission standards.

<sup>2</sup> Meets Tier 4 Final, Stage IV, Japan 2014 (Tier 4 Final) emission standards.

<sup>3</sup> Meets Tier 3/Stage IIIA/Japan 2006 (Tier 3) equivalent emission standards.

<sup>4</sup> Meets Tier 2/Stage II/Japan 2001 (Tier 2) equivalent emission standards.

<sup>A</sup> 374D and 390D hourly fuel rates are taken directly from customer machines registered on Product Link worldwide. Data from the top and bottom 5% of these customer machines has been excluded from the tables because it varies widely and therefore is not considered representative of what the remaining 90% of customers experience. Hourly fuel consumption for the 90% of machines in the tables also varies depending upon geographical region, load factor variation between units, etc. Cat machines are often used in more demanding applications which can account for differences between competitive models used in lighter duty applications. Consult your local Cat dealer for ways to more accurately estimate hourly fuel consumption for specific applications.

If the application of these machines is to be used for scrap handling, the LOW hourly fuel consumption rate would typically apply.

**NOTE:** Fuel consumption rates for 320D through 390D include machine at idle per load factor definition.

**EXCAVATORS**

Model	Low		Medium		High	
	liter	U.S. gal	liter	U.S. gal	liter	U.S. gal
<b>HEX D2 SERIES</b>						
312D2/313D2 <sup>3</sup> (STD 3054C)	3.6-7.1	<b>1.0-1.9</b>	7.1-10.7	<b>1.9-2.8</b>	10.7-14.2	<b>2.8-3.7</b>
312D2/313D2 <sup>3</sup> (ECO 3054C)	3.1-6.2	<b>0.8-1.6</b>	6.2-9.3	<b>1.6-2.5</b>	9.3-12.4	<b>2.5-3.3</b>
312D2 GC <sup>3</sup> (STD 3054C)	3.1-6.2	<b>0.8-1.6</b>	6.2-9.3	<b>1.6-2.5</b>	9.3-12.4	<b>2.5-3.3</b>
318D2 <sup>3</sup> (STD 3054CA)	4.5-8.9	<b>1.2-2.3</b>	8.9-13.4	<b>2.3-3.5</b>	13.4-17.8	<b>3.5-4.7</b>
318D2 <sup>3</sup> (ECO 3054CA)	3.9-7.8	<b>1.0-2.1</b>	7.8-11.8	<b>2.1-3.1</b>	11.8-15.7	<b>3.1-4.1</b>
320D2 <sup>2</sup> (STD C7.1 ACERT)	5.7-11.3	<b>1.5-3.0</b>	11.3-17.0	<b>3.0-4.5</b>	17.0-22.6	<b>4.5-6.0</b>
320D2 GC <sup>2</sup> (ECO C4.4 ACERT)	4.4-8.8	<b>1.2-2.3</b>	8.8-13.2	<b>2.3-3.5</b>	13.2-17.6	<b>3.5-4.6</b>
323D2 <sup>2</sup> (HHP C7.1 ACERT)	5.6-11.1	<b>1.5-2.9</b>	11.2-16.7	<b>2.9-4.4</b>	16.7-22.2	<b>4.4-5.9</b>
323D2 <sup>3</sup> (HHP C7.1 ACERT)	5.4-10.8	<b>1.4-2.9</b>	10.8-16.2	<b>2.9-4.3</b>	16.2-21.6	<b>4.3-5.7</b>
326D2 <sup>2</sup> (HHP C7.1 ACERT)	6.8-13.7	<b>1.8-3.6</b>	13.7-20.5	<b>3.6-5.4</b>	20.5-27.4	<b>5.4-7.2</b>
326D2 <sup>2</sup> (ECO C7.1 ACERT)	5.1-10.2	<b>1.3-2.7</b>	10.2-15.4	<b>2.7-4.1</b>	15.4-20.5	<b>4.1-5.4</b>
326D2 <sup>3</sup> (HHP C7.1 ACERT)	6.7-13.5	<b>1.8-3.6</b>	13.5-20.2	<b>3.6-5.3</b>	20.2-27.0	<b>5.3-7.1</b>
326D2 <sup>3</sup> (ECO C7.1 ACERT)	5.2-10.4	<b>1.4-2.7</b>	10.4-15.5	<b>2.7-4.1</b>	15.5-20.7	<b>4.1-5.5</b>
330D2 <sup>2</sup> (HHP C7.1 ACERT)	7.6-15.3	<b>2.0-4.0</b>	15.3-22.9	<b>4.0-6.0</b>	22.9-30.6	<b>6.0-8.1</b>
330D2 <sup>2</sup> (ECO C7.1 ACERT)	5.7-11.4	<b>1.5-3.0</b>	11.4-17.2	<b>3.0-4.5</b>	17.2-22.3	<b>4.5-5.9</b>
330D2 <sup>3</sup> (HHP C7.1 ACERT)	7.2-14.4	<b>1.9-3.8</b>	14.4-21.6	<b>3.8-5.7</b>	21.6-28.8	<b>5.7-7.6</b>
330D2 <sup>3</sup> (ECO C7.1 ACERT)	5.4-10.8	<b>1.4-2.9</b>	10.8-16.3	<b>2.9-4.3</b>	16.3-21.7	<b>4.3-5.7</b>
336D2/340D2 <sup>2A</sup> (C9 ACERT)	15.0-20.3	<b>4.0-5.3</b>	20.3-23.5	<b>5.3-6.2</b>	23.5-27.1	<b>6.2-7.2</b>
336D2 GC <sup>2A</sup> (C9 ACERT)	13.5-18.2	<b>3.6-4.8</b>	18.2-21.1	<b>4.8-5.6</b>	21.1-24.4	<b>5.6-6.5</b>
349D2 <sup>2</sup> (C13 ACERT)	14.8-29.6	<b>3.9-7.8</b>	29.6-44.4	<b>7.8-11.7</b>	44.4-59.2	<b>11.7-15.6</b>
349D2 <sup>3</sup> (C13 ACERT)	13.9-27.8	<b>3.7-7.3</b>	27.8-41.7	<b>7.3-11.0</b>	41.7-55.6	<b>11.0-14.7</b>
<b>HEX E SERIES</b>						
312E <sup>1</sup> (STD C4.4)	3.6-7.1	<b>0.9-1.9</b>	7.1-10.7	<b>1.9-2.8</b>	10.7-14.2	<b>2.8-3.8</b>
312E <sup>1</sup> (ECO C4.4)	3.2-6.3	<b>0.8-1.7</b>	6.3-9.5	<b>1.7-2.5</b>	9.5-12.6	<b>2.5-3.3</b>
314E <sup>1</sup> (STD C4.4)	3.1-6.2	<b>0.8-1.6</b>	6.2-9.3	<b>1.6-2.5</b>	9.3-12.4	<b>2.5-3.3</b>
314E <sup>1</sup> (ECO C4.4)	2.7-5.4	<b>0.7-1.4</b>	5.4-8.1	<b>1.4-2.1</b>	8.1-10.8	<b>2.1-2.9</b>
314E L <sup>1</sup> (STD C4.4)	3.5-7.1	<b>0.9-1.9</b>	7.1-10.6	<b>1.9-2.8</b>	10.6-14.2	<b>2.8-3.8</b>
314E L <sup>1</sup> (ECO C4.4)	2.9-5.7	<b>0.8-1.5</b>	5.7-8.6	<b>1.5-2.3</b>	8.6-11.5	<b>2.3-3.0</b>
316E <sup>1</sup> (STD C4.4)	4.5-9.1	<b>1.2-2.4</b>	9.1-13.6	<b>2.4-3.6</b>	13.6-18.2	<b>3.6-4.8</b>
316E <sup>1</sup> (ECO C4.4)	3.9-7.8	<b>1.0-2.1</b>	7.8-11.7	<b>2.1-3.1</b>	11.7-15.7	<b>3.1-4.1</b>
318E <sup>1</sup> (STD C4.4)	4.5-9.1	<b>1.2-2.4</b>	9.1-13.6	<b>2.4-3.6</b>	13.6-18.2	<b>3.6-4.8</b>
318E <sup>1</sup> (ECO C4.4)	3.9-7.8	<b>1.0-2.1</b>	7.8-11.7	<b>2.1-3.1</b>	11.7-15.7	<b>3.1-4.1</b>
320E <sup>1</sup> (HHP C6.6 ACERT)	6.1-12.1	<b>1.6-3.2</b>	12.1-18.2	<b>3.2-4.8</b>	18.2-24.2	<b>4.8-6.4</b>
320E <sup>1</sup> (SHP C6.6 ACERT)	5.6-11.2	<b>1.5-3.0</b>	11.2-16.8	<b>3.0-4.4</b>	16.8-22.4	<b>4.4-5.9</b>
324E <sup>1</sup> (C7.1 ACERT)	7.0-14.5	<b>1.8-3.8</b>	14.5-21.5	<b>3.8-5.7</b>	21.5-29.0	<b>5.7-7.7</b>
329E <sup>1</sup> (C7.1 ACERT)	8.5-17.0	<b>2.2-4.5</b>	17.0-25.5	<b>4.5-6.7</b>	25.5-34.5	<b>6.7-9.1</b>
336E <sup>1A</sup> (C9.3 ACERT)	13.5-22.0	<b>3.6-5.8</b>	22.0-29.0	<b>5.8-7.7</b>	29.0-36.0	<b>7.7-9.5</b>
349E <sup>1</sup> (C13 ACERT)	15.0-30.5	<b>4.0-8.1</b>	30.5-45.5	<b>8.1-12.0</b>	45.5-60.5	<b>12.0-16.0</b>

<sup>1</sup> Meets Tier 4 Interim/Stage IIIB/Japan 2011 (Tier 4 Interim) equivalent emission standards.

<sup>2</sup> Meets Tier 3/Stage IIIA/Japan 2006 (Tier 3) equivalent emission standards.

<sup>3</sup> Meets Tier 2/Stage II/Japan 2001 (Tier 2) equivalent emission standards.

<sup>A</sup> 336D2/340D2, 336D2 GC and 336E hourly fuel rates are taken directly from customer machines registered on Product Link worldwide. Data from the top and bottom 5% of these customer machines has been excluded from the tables because it varies widely and therefore is not considered representative of what the remaining 90% of customers experience. Hourly fuel consumption for the 90% of machines in the tables also varies depending upon geographical region, load factor variation between units, etc. Cat machines are often used in more demanding applications which can account for differences between competitive models used in lighter duty applications. Consult your local Cat dealer for ways to more accurately estimate hourly fuel consumption for specific applications.

**EXCAVATORS**

Model	Low		Medium		High	
	liter	U.S. gal	liter	U.S. gal	liter	U.S. gal
<b>HYBRID HEX E SERIES</b>						
336E H <sup>2A</sup> (C9.3 ACERT)	11.0-17.0	<b>2.9-4.5</b>	17.0-23.5	<b>4.5-6.2</b>	23.5-28.5	<b>6.2-7.5</b>
<b>HYBRID HEX F SERIES</b>						
336F XE <sup>1A</sup> (C9.3 ACERT)	9.8-14.3	<b>2.6-3.8</b>	14.3-19.4	<b>3.8-5.1</b>	19.4-23.8	<b>5.1-6.3</b>
<b>HEX F SERIES</b>						
311F <sup>1</sup> (STD C3.4)	2.7-5.3	<b>0.7-1.4</b>	5.3-8.0	<b>1.4-2.1</b>	8.0-10.6	<b>2.1-2.8</b>
311F <sup>1</sup> (ECO C3.4)	2.4-4.8	<b>0.6-1.3</b>	4.8-7.2	<b>1.3-1.9</b>	7.2-9.6	<b>1.9-2.5</b>
312F GC/313F L GC <sup>1</sup> (STD C3.4)	3.1-6.2	<b>0.8-1.6</b>	6.2-9.3	<b>1.6-2.5</b>	9.3-12.4	<b>2.5-3.3</b>
312F/313F L <sup>1</sup> (STD C4.4)	3.4-6.7	<b>0.9-1.8</b>	6.7-10.0	<b>1.8-2.6</b>	10.0-13.3	<b>2.6-3.5</b>
312F/313F L <sup>1</sup> (ECO C4.4)	2.7-5.4	<b>0.7-1.4</b>	5.4-8.1	<b>1.4-2.2</b>	8.1-10.8	<b>2.2-2.9</b>
314F <sup>1</sup> (STD C4.4)	2.9-5.8	<b>0.8-1.5</b>	5.8-8.6	<b>1.5-2.3</b>	8.6-11.5	<b>2.3-3.0</b>
314F <sup>1</sup> (ECO C4.4)	2.6-5.1	<b>0.7-1.3</b>	5.1-7.7	<b>1.3-2.0</b>	7.7-10.2	<b>2.0-2.7</b>
315F L <sup>1</sup> (STD C4.4)	3.3-6.6	<b>0.9-1.7</b>	6.6-10.0	<b>1.7-2.6</b>	10.0-13.3	<b>2.6-3.5</b>
315F L <sup>1</sup> (ECO C4.4)	2.8-5.7	<b>0.7-1.5</b>	5.7-8.5	<b>1.5-2.2</b>	8.5-11.4	<b>2.2-3.0</b>
316F L/318F L <sup>1</sup> (STD C4.4)	4.2-8.3	<b>1.1-2.2</b>	8.3-12.4	<b>2.2-3.3</b>	12.4-16.5	<b>3.3-4.4</b>
316F L/318F L <sup>1</sup> (ECO C4.4)	3.6-7.2	<b>1.0-1.9</b>	7.2-10.8	<b>1.9-2.9</b>	10.8-14.4	<b>2.9-3.8</b>
320F <sup>1</sup> (STD C4.4 ACERT)	5.4-10.9	<b>1.4-2.9</b>	10.9-16.3	<b>2.9-4.3</b>	16.3-21.8	<b>4.3-5.7</b>
320F <sup>1</sup> (ECO C4.4 ACERT)	4.5-8.9	<b>1.2-2.4</b>	8.9-13.4	<b>2.4-3.5</b>	13.4-17.8	<b>3.5-4.7</b>
323F <sup>1</sup> (HHP C7.1 ACERT)	5.4-10.8	<b>1.4-2.9</b>	10.8-16.2	<b>2.9-4.3</b>	16.2-21.6	<b>4.3-5.7</b>
323F <sup>1</sup> (STD C7.1 ACERT)	5.1-10.1	<b>1.3-2.7</b>	10.1-15.2	<b>2.7-4.0</b>	15.2-20.2	<b>4.0-5.3</b>
323F <sup>1</sup> (ECO C7.1 ACERT)	4.3-8.6	<b>1.1-2.3</b>	8.6-12.9	<b>2.3-3.4</b>	12.9-17.2	<b>3.4-4.5</b>
325F L <sup>1</sup> (HHP C4.4 ACERT)	5.9-11.8	<b>1.6-3.1</b>	11.8-17.7	<b>3.1-4.7</b>	17.7-23.6	<b>4.7-6.2</b>
325F L <sup>1</sup> (STD C4.4 ACERT)	5.6-11.2	<b>1.5-3.0</b>	11.2-16.7	<b>3.0-4.4</b>	16.7-22.3	<b>4.4-5.9</b>
325F L <sup>1</sup> (ECO C4.4 ACERT)	4.6-9.2	<b>1.2-2.4</b>	9.2-13.9	<b>2.4-3.7</b>	13.9-18.5	<b>3.7-4.9</b>
326F <sup>1</sup> (HHP C7.1 ACERT)	6.5-13.0	<b>1.7-3.4</b>	13.0-19.5	<b>3.4-5.1</b>	19.5-26.0	<b>5.1-6.9</b>
326F <sup>1</sup> (STD C7.1 ACERT)	6.0-12.0	<b>1.6-3.2</b>	12.0-18.0	<b>3.2-4.8</b>	18.0-24.0	<b>4.8-6.3</b>
326F <sup>1</sup> (ECO C7.1 ACERT)	4.9-9.7	<b>1.3-2.6</b>	9.7-14.6	<b>2.6-3.9</b>	14.6-19.4	<b>3.9-5.1</b>
330F <sup>1</sup> (HHP C7.1 ACERT)	8.0-16.0	<b>2.1-4.2</b>	16.0-24.1	<b>4.2-6.4</b>	24.1-32.1	<b>6.4-8.5</b>
330F <sup>1</sup> (STD C7.1 ACERT)	7.8-15.5	<b>2.1-4.1</b>	15.5-23.3	<b>4.1-6.2</b>	23.3-31.0	<b>6.2-8.2</b>
330F <sup>1</sup> (ECO C7.1 ACERT)	6.4-12.7	<b>1.7-3.4</b>	12.7-19.1	<b>3.4-5.0</b>	19.1-25.4	<b>5.0-6.7</b>
335F L <sup>1</sup> (HHP C7.1 ACERT)	7.8-15.6	<b>2.1-4.1</b>	15.6-23.4	<b>4.1-6.2</b>	23.4-31.2	<b>6.2-8.2</b>
335F L <sup>1</sup> (STD C7.1 ACERT)	7.0-14.1	<b>1.8-3.7</b>	14.1-21.1	<b>3.7-5.6</b>	21.1-28.2	<b>5.6-7.4</b>
335F L <sup>1</sup> (ECO C7.1 ACERT)	5.9-11.2	<b>1.6-3.0</b>	11.2-17.8	<b>3.0-4.7</b>	17.8-23.8	<b>4.7-6.3</b>
336F <sup>1A</sup> (C9.3 ACERT)	12.0-18.5	<b>3.2-4.9</b>	18.5-24.0	<b>4.9-6.3</b>	24.0-30.0	<b>6.3-7.9</b>
349F <sup>1</sup> (C13 ACERT)	14.7-29.5	<b>3.9-7.8</b>	29.5-44.2	<b>7.8-11.7</b>	44.2-59.0	<b>11.7-15.6</b>
374F <sup>1A</sup> (C15 ACERT)	19.0-32.0	<b>5.0-8.5</b>	32.0-42.0	<b>8.5-11.1</b>	42.0-49.0	<b>11.1-12.9</b>
374F <sup>3A</sup> (C15 ACERT)	20.1-33.8	<b>5.3-8.9</b>	33.8-44.3	<b>8.9-11.7</b>	44.3-51.7	<b>11.7-13.7</b>
374F <sup>4A</sup> (C15 ACERT)	19.2-32.4	<b>5.1-8.6</b>	32.4-42.5	<b>8.6-11.2</b>	42.5-49.5	<b>11.2-13.1</b>
390F <sup>1A</sup> (C18 ACERT)	22.0-39.0	<b>5.8-10.3</b>	39.0-50.0	<b>10.3-13.2</b>	50.0-63.0	<b>13.2-16.6</b>
390F <sup>3A</sup> (C18 ACERT)	22.2-39.4	<b>5.9-10.4</b>	39.4-50.5	<b>10.4-13.3</b>	50.5-63.7	<b>13.3-16.8</b>
390F <sup>4A</sup> (C18 ACERT)	21.3-37.8	<b>5.6-10.0</b>	37.8-48.4	<b>10.0-12.8</b>	48.4-61.0	<b>12.8-16.1</b>

<sup>1</sup> Meets Tier 4 Final/Stage IV/Japan 2014 (Tier 4 Final) emission standards.

<sup>2</sup> Meets Tier 4 Interim/Stage IIIB/Japan 2011 (Tier 4 Interim) equivalent emission standards.

<sup>3</sup> Meets Tier 3/Stage IIIA/Japan 2006 (Tier 3) equivalent emission standards.

<sup>4</sup> Meets Tier 2/Stage II/Japan 2001 (Tier 2) equivalent emission standards.

<sup>A</sup> 336EH, 336F, 336F XE, 374F and 390F hourly fuel rates are taken directly from customer machines registered on Product Link worldwide. Data from the top and bottom 5% of these customer machines has been excluded from the tables because it varies widely and therefore is not considered representative of what the remaining 90% of customers experience. Hourly fuel consumption for the 90% of machines in the tables also varies depending upon geographical region, load factor variation between units, etc. Cat machines are often used in more demanding applications which can account for differences between competitive models used in lighter duty applications. Consult your local Cat dealer for ways to more accurately estimate hourly fuel consumption for specific applications.

**EXCAVATORS**

Model	Low		Medium		High	
	liter	U.S. gal	liter	U.S. gal	liter	U.S. gal
<b>TRACK MATERIAL HANDLERS</b>						
385C MH	48-60	<b>12.7-15.8</b>	60-74	<b>15.8-19.5</b>	74-82	<b>19.5-21.7</b>
<b>WHEEL HEX</b>						
<b>D Series</b>						
M313D	7.5-11.6	<b>2.0-3.1</b>	11.6-16.4	<b>3.1-4.3</b>	16.4-19.2	<b>4.3-5.1</b>
M315D	8.7-13.1	<b>2.3-3.5</b>	13.1-18.1	<b>3.5-4.8</b>	18.1-21.0	<b>4.8-5.6</b>
M316D	7.9-11.8	<b>2.1-3.1</b>	11.8-17.1	<b>3.1-4.5</b>	17.1-20.3	<b>4.5-5.4</b>
M318D	9.1-13.3	<b>2.4-3.5</b>	13.3-18.2	<b>3.5-4.8</b>	18.2-21.7	<b>4.8-5.7</b>
M318D MH	9.1-13.3	<b>2.4-3.5</b>	13.3-18.2	<b>3.5-4.8</b>	18.2-21.7	<b>4.8-5.7</b>
M322D	11.6-17.5	<b>3.1-4.6</b>	17.5-23.3	<b>4.6-6.1</b>	23.3-26.9	<b>6.1-7.1</b>
M322D MH	11.6-17.5	<b>3.1-4.6</b>	17.5-23.3	<b>4.6-6.1</b>	23.3-26.9	<b>6.1-7.1</b>
<b>D2 Series</b>						
M315D2	7.5-11.6	<b>2.0-3.1</b>	11.6-16.4	<b>3.1-4.3</b>	16.4-19.2	<b>4.3-5.1</b>
M317D2	8.7-13.1	<b>2.3-3.5</b>	13.1-18.1	<b>3.5-4.8</b>	18.1-21.0	<b>4.8-5.6</b>
<b>F Series</b>						
M314F	4.9-7.8	<b>1.3-2.1</b>	7.8-8.8	<b>2.1-2.3</b>	8.8-11.8	<b>2.3-3.1</b>
M316F	6.4-8.6	<b>1.7-2.3</b>	8.6-9.6	<b>2.3-2.5</b>	9.6-12.9	<b>2.5-3.4</b>
M318F	5.6-8.9	<b>1.5-2.4</b>	8.9-11.1	<b>2.4-2.9</b>	11.1-13.4	<b>2.9-3.5</b>
M320F	5.7-9.1	<b>1.5-2.4</b>	9.1-11.4	<b>2.4-3.0</b>	11.4-13.7	<b>3.0-3.6</b>
M322F	7.4-10.3	<b>2.0-2.7</b>	10.3-11.8	<b>2.7-3.1</b>	11.8-14.2	<b>3.1-3.9</b>
<b>MATERIAL HANDLER</b>						
M325D MH	13-18	<b>3.4-4.8</b>	19-23	<b>5.0-6.1</b>	24-28	<b>6.3-7.4</b>
M325D LMH	14-20	<b>3.7-5.3</b>	21-26	<b>5.5-6.9</b>	27-32	<b>7.1-8.5</b>
MH3022	5.7-9.1	<b>1.5-2.4</b>	9.1-11.4	<b>2.4-3.0</b>	11.4-13.7	<b>3.0-3.6</b>
MH3024	7.4-10.3	<b>2.0-2.7</b>	10.3-11.8	<b>2.7-3.1</b>	11.8-14.2	<b>3.1-3.7</b>
MH3037	15-17	<b>4.0-4.5</b>	18-20	<b>4.8-5.3</b>	21-23	<b>5.5-6.1</b>
MH3049	17-19	<b>4.5-5.0</b>	20-22	<b>5.3-5.8</b>	23-25	<b>6.1-6.6</b>
MH3059	20-22	<b>5.3-5.8</b>	23-25	<b>6.1-6.6</b>	26-28	<b>6.9-7.4</b>

**Mini HEX**

**Typical Application Description**

(relative to work application)

- Low Mostly shallow depth urban utility construction where excavator sets pipe and digs in sandy loam or free flowing, low density material. Little traveling and little or no impact.
- Medium Most residential pipeline and cabling applications. Continuous mass excavation and trenching in natural bed clay soils. Some traveling and steady, full throttle operation.
- High Continuous trenching or truck loading in rock or shot rock soils. Most pipeline applications in hard rocky material. Large amount of travel over rough ground. Constant high load factor and high impact.

**Load Factor Guide**

(average engine load factor based on application description for each range)

- Low 20%-40%
- Medium 40%-60%
- High 60%-80%

**300 Series**

**Typical Application Description**

(relative to work application)

- Low Mostly shallow depth urban utility construction where excavator sets pipe and digs less than 50% of the daily work schedule. Sandy loam, free flowing, low density material. Little traveling and little or no impact.
- Medium Most residential sewer applications. Continuous mass excavation and trenching in natural bed clay soils. Digging 60-85% of the daily work schedule. Most log loading applications. Some traveling and steady, full throttle operation.
- High Continuous trenching or truck loading in rock or shot rock soils. Most pipeline applications in hard rocky material. Digging 90-95% of the daily work schedule. Large amount of travel over rough ground. Working on rock floor with constant high load factor and high impact.

**Load Factor Guide**

(average engine load factor based on application description for each range)

- Low 20%-40%
- Medium 40%-60%
- High 60%-80%

**M Series**

**Typical Application Description**

(relative to work application)

- Low Urban utility construction application in sandy loam, low density material. Digging less than 50% of the daily work schedule. Rehandling and scrap handling applications.
- Medium Residential sewer applications in natural bed clay. Continuous digging in sandy clay/gravel. Digging 60-85% of the daily work schedule. Site development and lumber yard applications. Most logging applications.
- High Pipeline applications in hard rocky material. Continuous digging in rock/natural bed clay. Digging 90-95% of the daily work schedule. High impact, using hammer, working in forests and quarries.

**Load Factor Guide**

(average engine load factor based on application description for each range)

- Low 20%-40%
- Medium 40%-60%
- High 60%-80%

**HYDRAULIC MINING SHOVELS**

Model	Low		Medium		High	
	liter	U.S. gal	liter	U.S. gal	liter	U.S. gal
6015/6015 FS	66-80	<b>17-21</b>	80-93	<b>21-25</b>	93-106	<b>25-28</b>
6018/6018 FS	105-126	<b>28-33</b>	126-147	<b>33-39</b>	147-168	<b>39-44</b>
6020B	92-111	<b>24-29</b>	111-129	<b>29-34</b>	129-148	<b>34-39</b>
6030/6030 FS	134-161	<b>35-43</b>	161-188	<b>43-50</b>	188-215	<b>50-57</b>
6040/6040 FS	180-216	<b>48-57</b>	216-252	<b>57-67</b>	252-288	<b>67-76</b>
6050/6050 FS	229-275	<b>60-73</b>	275-321	<b>73-85</b>	321-367	<b>85-97</b>
6060/6060 FS	276-331	<b>73-87</b>	331-387	<b>87-102</b>	387-442	<b>102-117</b>
6090 FS	402-483	<b>106-128</b>	483-563	<b>128-149</b>	563-644	<b>149-170</b>

**Typical Application Description**

(relative to work application)

Low Light duty work with a considerable amount of idling.

Medium Continuous loading operations with frequent idling periods.  
 (Applies for the vast majority of applications)

High Continuous hard digging operations with rare idling periods.

**Load Factor Guide**

(average engine load factor based on application description for each range)

Low 50%-60%

Medium 60%-70%

High 70%-80%

**WHEEL TRACTOR-SCRAPERS**

Model	Low		Medium		High	
	liter	U.S. gal	liter	U.S. gal	liter	U.S. gal
621K <sup>1</sup>	28.0-39.4	<b>7.4-10.4</b>	39.4-50.7	<b>10.4-13.4</b>	50.7-62.1	<b>13.4-16.4</b>
623K <sup>1</sup>	32.2-43.2	<b>8.5-11.4</b>	43.2-54.5	<b>11.4-14.4</b>	54.5-68.1	<b>14.4-18.0</b>
627K <sup>1</sup>	42.0-61.7	<b>11.1-16.3</b>	61.7-81.4	<b>16.3-21.5</b>	81.4-106.7	<b>21.5-28.2</b>
631K <sup>1</sup>	41.00-46.13	<b>10.76-12.30</b>	54.33-60.48	<b>14.35-15.89</b>	73-80-79.95	<b>19.48-21.01</b>
637K <sup>1</sup>	65.60-71.75	<b>17.43-18.96</b>	89.18-95.33	<b>23.58-25.11</b>	116.34-124.03	<b>30.75-32.80</b>
657G <sup>2</sup>	66.6-98.8	<b>17.6-26.1</b>	98.8-131.0	<b>26.1-34.6</b>	131.0-163.2	<b>34.6-43.1</b>

<sup>1</sup> Meets Tier 4 Final/Stage IV/Japan 2014 (Tier 4 Final) emission standards. Machine requires the use of DEF fluid with consumption rate approximately 2-3% of diesel fuel.

<sup>2</sup> Meets Tier 3/Stage IIIA/Japan 2006 (Tier 3) equivalent emission standards.

**Typical Application Description**

(relative to work application)

- Low Level or favorable grades on good haul roads and low rolling resistance. Easy-loading materials, partial loads. No impact. Average use, but with considerable idling.
- Medium Adverse and favorable grades with varying loading and haul road conditions. Long and short hauls, near full. Some impact. Typical road building use.
- High Rough haul roads. Loading heavy clay, continuous high total resistance conditions with steady cycling. Overloading. High impact conditions, such as loading ripped rock.

**Load Factor Guide**

(average engine load factor based on application description for each range)

- Low 35%-50%
- Medium 50%-65%
- High 65%-80%

**BACKHOE LOADERS**

Model	Low		Medium		High	
	liter	U.S. gal	liter	U.S. gal	liter	U.S. gal
415F2 <sup>1</sup> 55 kW/74 hp	1.9-7.5	0.5-2.0	7.5-10.5	2.0-2.8	10.5-13.9	2.8-3.7
416F2 <sup>1</sup> 70 kW/94 hp	2.6-12.4	0.7-3.3	12.4-17.4	3.3-4.6	17.4-19.0	4.6-5.0
420F2 <sup>3</sup> 74.5 kW/100 hp	2.6-11.7	0.7-3.1	11.7-17.4	3.1-4.6	17.4-20.1	4.6-5.3
420F2 <sup>1</sup> 74.5 kW/100 hp	2.9-13.6	0.8-3.6	13.6-18.9	3.6-5.0	18.9-19.7	5.0-5.2
422F2 <sup>3</sup> 56.5 kW/75 hp	1.9-7.9	0.5-2.1	7.9-12.1	2.1-3.2	12.1-14.4	3.2-3.8
422F2 <sup>3</sup> 68.5 kW/92 hp	2.6-11.7	0.7-3.1	11.7-16.7	3.1-4.4	16.7-18.9	4.4-5.0
427F2 <sup>1</sup> 55 kW/74 hp	1.9-7.5	0.5-2.0	7.5-10.5	2.0-2.8	10.5-13.9	2.8-3.7
428F2 <sup>3</sup> 70 kW/94 hp	2.6-11.0	0.7-2.9	11.0-16.7	2.9-4.4	16.7-19.3	4.4-5.1
428F2 <sup>3</sup> 74.5 kW/100 hp	2.6-11.7	0.7-3.1	11.7-17.4	3.1-4.6	17.4-20.1	4.6-5.3
428F2 <sup>2</sup> 70 kW/94 hp	2.6-11.0	0.7-2.9	11.0-16.7	2.9-4.4	16.7-19.3	4.4-5.1
428F2 <sup>2</sup> 74.5 kW/100 hp	2.6-11.4	0.7-3.0	11.4-17.0	3.0-4.5	17.0-20.8	4.5-5.5
428F2 <sup>1</sup> 70 kW/94 hp	2.6-12.4	0.7-3.3	12.4-17.4	3.3-4.6	17.4-19.0	4.6-5.0
428F2 <sup>1</sup> 74.5 kW/100 hp	2.9-13.6	0.8-3.6	13.6-18.9	3.6-5.0	18.9-19.7	5.0-5.2
430F2 <sup>3</sup> 74.5 kW/100 hp	2.6-11.7	0.7-3.1	11.7-17.4	3.1-4.6	17.4-20.1	4.6-5.3
430F2 <sup>1</sup> 86 kW/115 hp	3.1-14.8	0.8-3.9	14.8-20.9	3.9-5.5	20.9-22.8	5.5-6.0
432F2 <sup>3</sup> 74.5 kW/100 hp	2.6-11.7	0.7-3.1	11.7-17.4	3.1-4.6	17.4-20.1	4.6-5.3
432F2 <sup>2</sup> 74.5 kW/100 hp	2.6-11.4	0.7-3.0	11.4-17.0	3.0-4.5	17.0-20.8	4.5-5.5
432F2 <sup>1</sup> 82 kW/110 hp	2.9-13.7	0.8-3.6	13.7-19.0	3.6-5.0	19.0-21.9	5.0-5.8
434F2 <sup>3</sup> 68.5 kW/92 hp	2.6-11.7	0.7-3.1	11.7-16.7	3.1-4.4	16.7-18.9	4.4-5.0
434F2 <sup>3</sup> 74.5 kW/100 hp	2.6-11.7	0.7-3.1	11.7-17.4	3.1-4.6	17.4-20.1	4.6-5.3
434F2 <sup>2</sup> 70 kW/94 hp	2.6-11.0	0.7-2.9	11.0-16.7	2.9-4.4	16.7-19.3	4.4-5.1
434F2 <sup>2</sup> 74.5 kW/100 hp	2.6-11.4	0.7-3.0	11.4-17.0	3.0-4.5	17.0-20.8	4.5-5.5
434F2 <sup>1</sup> 74.5 kW/100 hp	2.9-13.6	0.8-3.6	13.6-18.9	3.6-5.0	18.9-19.7	5.0-5.2
444F2 <sup>3</sup> 74.5 kW/100 hp	2.6-11.7	0.7-3.1	11.7-17.4	3.1-4.6	17.4-20.1	4.6-5.3
444F2 <sup>2</sup> 74.5 kW/100 hp	2.6-11.4	0.7-3.0	11.4-17.0	3.0-4.5	17.0-20.8	4.5-5.5
444F2 <sup>1</sup> 82 kW/110 hp	2.9-13.7	0.8-3.6	13.7-19.0	3.6-5.0	19.0-21.9	5.0-5.8
450F <sup>1</sup> 106 kW/142 hp	3.3-16.2	0.9-4.3	16.2-23.1	4.3-6.1	23.1-27.1	6.1-7.2

<sup>1</sup> Meets Tier 4 Final/Stage IV/Japan 2014 (Tier 4 Final) emission standards.

<sup>2</sup> Meets Tier 3/Stage IIIA/Japan 2006 (Tier 3) equivalent emission standards.

<sup>3</sup> Meets Tier 2/Stage II/Japan 2001 (Tier 2) equivalent emission standards.

**Typical Application Description**

(relative to work application)

**Low** Light duty utility applications with intermittent cycles in light to medium soil. Trenching depths less than 1.83 m (**6 feet**).

**Medium** General utility applications with regular cycles in medium to heavy soil. Dig depths to 3.05 m (**10 feet**). Occasional use of constant flow implements.

**High** Production applications or digging in rock. Dig depths over 3.05 m (**10 feet**). Long cycle times or regular use of constant flow implements.

**Load Factor Guide**

(average engine load factor based on application description for each range)

**Low** 20%-40%

**Medium** 40%-65%

**High** 65%-80%



**FOREST PRODUCTS**

Model	Low		Medium		High	
	liter	U.S. gal	liter	U.S. gal	liter	U.S. gal
<b>FOREST MACHINES</b>						
320D2 FM <sup>3</sup>	11.4-15.9	<b>3.0-4.2</b>	15.9-19.7	<b>4.2-5.2</b>	19.7-24.6	<b>5.2-6.5</b>
320D2 FM LL <sup>3</sup>	9.5-14.4	<b>2.5-3.8</b>	14.4-18.9	<b>3.8-5.0</b>	18.9-23.5	<b>5.0-6.2</b>
538 <sup>1</sup>	7.6-13.2	<b>2.0-3.5</b>	13.2-17.0	<b>3.5-4.5</b>	17.0-20.8	<b>4.5-5.5</b>
538 LL <sup>1</sup>	7.6-12.1	<b>2.0-3.2</b>	12.1-15.9	<b>3.2-4.2</b>	15.9-19.7	<b>4.2-5.2</b>
324D FM <sup>3</sup>	14.0-22.0	<b>3.7-5.8</b>	22.0-26.1	<b>5.8-6.9</b>	26.1-30.0	<b>6.9-7.9</b>
324D FM LL <sup>3</sup>	14.0-22.0	<b>3.7-5.8</b>	22.0-26.1	<b>5.8-6.9</b>	26.1-30.0	<b>6.9-7.9</b>
325D FM <sup>3</sup>	14.0-23.1	<b>3.7-6.1</b>	23.1-26.9	<b>6.1-7.1</b>	26.9-34.1	<b>7.1-9.0</b>
325D FM LL <sup>3</sup>	14.0-23.1	<b>3.7-6.1</b>	23.1-26.9	<b>6.1-7.1</b>	26.9-34.1	<b>7.1-9.0</b>
558 <sup>1</sup>	13.2-18.9	<b>3.5-5.0</b>	18.9-26.5	<b>5.0-7.0</b>	26.5-31.0	<b>7.0-8.2</b>
558 LL <sup>1</sup>	11.4-18.2	<b>3.0-4.8</b>	18.2-25.7	<b>4.8-6.8</b>	25.7-30.3	<b>6.8-8.0</b>
568 <sup>2</sup>	22.0-29.1	<b>5.8-7.7</b>	29.1-34.1	<b>7.7-9.0</b>	34.1-39.0	<b>9.0-10.3</b>
568 LL <sup>2</sup>	22.0-29.1	<b>5.8-7.7</b>	29.1-34.1	<b>7.7-9.0</b>	34.1-39.0	<b>9.0-10.3</b>
<b>FELLER BUNCHERS</b>						
521B <sup>3</sup>	28.0-33.7	<b>7.4-8.9</b>	33.7-37.9	<b>8.9-10.0</b>	37.9-45.4	<b>10.0-12.0</b>
522B <sup>3</sup>	28.0-33.7	<b>7.4-8.9</b>	33.7-37.9	<b>8.9-10.0</b>	37.9-45.4	<b>10.0-12.0</b>
541 Series 2 <sup>3</sup>	28.4-34.1	<b>7.5-9.0</b>	34.1-41.6	<b>9.0-11.0</b>	41.6-54.1	<b>11.0-14.3</b>
552 Series 2 <sup>3</sup>	30.7-34.1	<b>8.1-9.0</b>	34.1-43.5	<b>9.0-11.5</b>	43.5-56.8	<b>11.5-15.0</b>
<b>TRACK SKIDDERS</b>						
527	13.2-18.9	<b>3.5-5.0</b>	18.9-23.6	<b>5.0-6.25</b>	23.6-32.2	<b>6.25-8.5</b>
<b>WHEEL SKIDDERS</b>						
525D <sup>1</sup>	15.1-17.8	<b>4.0-4.7</b>	17.8-20.8	<b>4.7-5.5</b>	20.8-24.6	<b>5.5-6.5</b>
535D <sup>1</sup>	16.3-18.9	<b>4.3-5.0</b>	18.9-22.0	<b>5.0-5.8</b>	22.0-24.6	<b>5.8-6.5</b>
545D <sup>1</sup>	17.0-19.7	<b>4.5-5.2</b>	19.7-23.8	<b>5.2-6.3</b>	23.8-27.3	<b>6.3-7.2</b>
555D <sup>1</sup>	18.9-21.6	<b>5.0-5.7</b>	21.6-24.6	<b>5.7-6.5</b>	24.6-28.4	<b>6.5-7.5</b>
525D <sup>3</sup>	14.3-17.0	<b>3.8-4.5</b>	17.0-20.0	<b>4.5-5.3</b>	20.0-23.8	<b>5.3-6.3</b>
535D <sup>3</sup>	15.5-18.1	<b>4.1-4.8</b>	18.1-21.2	<b>4.8-5.6</b>	21.2-23.8	<b>5.6-6.3</b>
545D <sup>3</sup>	16.2-18.9	<b>4.3-5.0</b>	18.9-23.0	<b>5.0-6.1</b>	23.0-26.5	<b>6.1-7.0</b>
555D <sup>3</sup>	18.1-20.8	<b>4.8-5.5</b>	20.8-23.8	<b>5.5-6.3</b>	23.8-27.6	<b>6.3-7.3</b>
<b>KNUCKLEBOOM LOADERS</b>						
529 <sup>3</sup>	12.04	<b>3.31</b>	19.47	<b>5.36</b>	25.58	<b>7.04</b>
559C <sup>2</sup>	12.91	<b>3.55</b>	19.69	<b>5.42</b>	25.96	<b>7.15</b>
579 <sup>2</sup>	12.91	<b>3.55</b>	19.69	<b>5.42</b>	25.96	<b>7.15</b>
<b>HARVESTERS</b>						
501HD <sup>3</sup>	—	—	—	—	—	—
521B <sup>3</sup>	20.8-26.5	<b>5.5-7.0</b>	26.5-32.2	<b>7.0-8.5</b>	32.2-41.6	<b>8.5-11.0</b>
522B <sup>3</sup>	20.8-26.5	<b>5.5-7.0</b>	26.5-32.2	<b>7.0-8.5</b>	32.2-41.6	<b>8.5-11.0</b>
541 Series 2 <sup>3</sup>	24.6-30.3	<b>6.5-8.0</b>	30.3-36.0	<b>8.0-9.5</b>	36.0-45.4	<b>9.5-12.0</b>
552 Series 2 <sup>3</sup>	24.6-30.3	<b>6.5-8.0</b>	30.3-36.0	<b>8.0-9.5</b>	36.0-45.4	<b>9.5-12.0</b>
<b>FORWARDERS</b>						
564 <sup>3</sup>	13.2	<b>3.5</b>	15.0	<b>4.0</b>	17.0	<b>4.5</b>
574 <sup>3</sup>	14.4	<b>3.8</b>	15.9	<b>4.2</b>	17.8	<b>4.7</b>
584 <sup>3</sup>	12.5	<b>3.3</b>	14.0	<b>3.7</b>	17.0	<b>4.5</b>
584HD <sup>3</sup>	13.0	<b>3.4</b>	14.3	<b>3.8</b>	18.9	<b>5.0</b>

<sup>1</sup> Meets Tier 4 Final/Stage IV/Japan 2014 (Tier 4 Final) emission standards.

<sup>2</sup> Meets Tier 4 Interim/Stage IIIB/Japan 2011 (Tier 4 Interim) equivalent emission standards.

<sup>3</sup> Meets Tier 3/Stage IIIA/Japan 2006 (Tier 3) equivalent emission standards.

**Wheel Skidders**

**Typical Application Description**

(relative to work application)

- Low Intermittent skidding for short distances, no decking. Good underfoot conditions; dry floor, few if any stumps, flat/level terrain with low skidding resistance.
- Medium Continuous turning, steady skidding for medium distances with moderate decking. Good underfoot conditions; dry floor with few stumps, gradual rolling/moderate terrain with medium skidding resistance.
- High Continuous turning, steady skidding for long distances with frequent decking. Poor underfoot conditions; wet floor, numerous stumps, steep terrain with high skidding resistance.

**Load Factor Guide — 517**

- Low Skidding loads less than 4536 kg (**10,000 lb**) in flat terrain (0-8% grade) with low skidding resistance.
- Medium Skidding loads up to 4536 kg (**10,000 lb**) in moderate terrain (8-30% grade) with medium skidding resistance.
- High Skidding loads over 4536 kg (**10,000 lb**) in steep terrain (over 30% grade) with high skidding resistance.

**Load Factor Guide — D Series WSK**

- Low Skidding loads less than 6350 kg (**14,000 lb**) in flat terrain (0-5% grade) with low skidding resistance.
- Medium Skidding loads up to 7257 kg (**16,000 lb**) in moderate terrain (5-10% grade) with average skidding resistance
- High Skidding loads over 8165 kg (**18,000 lb**) in steep terrain (over 10% grade) with high skidding resistance.

**Load Factor Guide — 527**

- Low Skidding loads less than 6360 kg (**14,000 lb**) in flat terrain (0-8% grade) with low skidding resistance.
- Medium Skidding loads up to 6360 kg (**14,000 lb**) in moderate terrain (8-30% grade) with medium skidding resistance.
- High Skidding loads over 6360 kg (**14,000 lb**) in steep terrain (over 30% grade) with high skidding resistance.

**Forest Machines**

**Typical Application Description**

(relative to work application)

- Low Millyard application, log loader or processing application in best underfoot conditions. Flat ground, uniform cut processed lengths 12 m (**40 feet**), or shorter.
- Medium Light to medium shovel, log loader or processing application in better underfoot conditions. Medium slopes and trees 500 mm (**20 inches**) or medium size full trees.
- High Heavy shovel logging in poor underfoot conditions or steep terrain and heavy duty processing applications. Multiple large full trees with DBH of 635 mm (**25 inches**) or larger.

**Load Factor Guide**

(average engine load factor based on application description for each range)

- Low 25%-45%
- Medium 45%-65%
- High 65%-85%

**Feller Bunchers**

**Typical Application Description**

(relative to work application)

- Low Intermittent felling and stacking, good underfoot conditions and flat ground. Uniform trees below 255 mm **(10 inches)**.
- Medium Feller buncher applications in average underfoot conditions and rolling terrain. Some trees up to 457 mm **(18 inches)**.
- High High cycle feller buncher applications in poor underfoot conditions, steep terrain, maneuvering over stumps, rocks and fallen trees. Accumulation of multiple small diameter trees or individual harvest of larger trees, including hardwoods, over 508 mm **(20 inches)**.

**Load Factor Guide**

(average engine load factor based on application description for each range)

- Low 45%-65%
- Medium 65%-85%
- High 85%-98%

**Harvesters**

**Typical Application Description**

(relative to work application)

- Low Light duty harvesting and processing applications in good underfoot conditions and flat ground. Primarily uniform softwood trees below 255 mm **(10 inches)**.
- Medium Harvesting and processing applications in average underfoot conditions and rolling terrain. Primarily softwood trees and a few hardwoods up to 457 mm **(18 inches)**.
- High High cycling harvesting and processing in poor underfoot conditions, steep terrain, maneuvering over stumps, rocks and fallen trees. Multiple small diameter trees or individual harvest of larger trees, including hardwoods, over 508 mm **(20 inches)**.

**Load Factor Guide**

(average engine load factor based on application description for each range)

- Low 38%-55%
- Medium 55%-72%
- High 72%-83%

**Forwarders**

**Typical Application Description**

(relative to work application)

- Low Loading and hauling application in good conditions. Flat ground, concentrated log bunches, single tier log lengths, short haul distances.
- Medium Loading and hauling application in medium conditions. Rolling terrain, medium spacing of log bunches, single and two tier log lengths.
- High Loading and hauling application in poor conditions, steep or rocky terrain, scattered log bunches, two tier log lengths, long haul distances.

**Load Factor Guide**

(average engine load factor based on application description for each range)

- Low 15%-25%
- Medium 25%-35%
- High 35%-45%

**MINING & OFF-HIGHWAY TRUCKS**

Model	Low		Medium		High	
	liter	U.S. gal	liter	U.S. gal	liter	U.S. gal
770G <sup>1,2</sup>	12.5-16.5	<b>3.3-4.3</b>	16.5-21.5	<b>4.3-5.6</b>	21.5-27.0	<b>5.6-7.1</b>
772G <sup>1,2</sup>	14.5-18.0	<b>3.8-4.7</b>	18.0-24.0	<b>4.7-6.3</b>	24.0-32.0	<b>6.3-8.4</b>
773E <sup>3</sup>	—	—	—	—	—	—
773G <sup>2</sup>	18.5-28.0	<b>4.9-7.3</b>	28.0-35.0	<b>7.3-9.2</b>	35.0-43.0	<b>9.2-11.3</b>
775G <sup>2</sup>	24.0-28.5	<b>6.3-7.5</b>	28.5-36.0	<b>7.5-9.4</b>	36.0-47.0	<b>9.4-12.3</b>
777E <sup>3</sup>	—	—	—	—	—	—
777G <sup>2</sup>	33.0-46.0	<b>8.7-12.1</b>	46.0-57.0	<b>12.1-15.0</b>	56.5-72.5	<b>14.8-19.0</b>
785C 1450 HP <sup>4</sup>	53.7-80.6	<b>14.2-21.3</b>	80.6-107.5	<b>21.3-28.4</b>	107.5-134.4	<b>28.4-35.5</b>
785D 1450 HP <sup>5</sup>	54.2-81.4	<b>14.3-21.5</b>	81.4-108.5	<b>21.5-28.7</b>	108.5-135.6	<b>28.7-35.8</b>
789D 1900 HP <sup>4</sup>	70.6-105.9	<b>18.7-28.0</b>	105.9-141.2	<b>28.0-37.3</b>	141.2-176.5	<b>37.3-46.6</b>
789D 2100 HP <sup>4</sup>	74.9-112.4	<b>19.8-29.7</b>	112.4-149.9	<b>29.7-39.6</b>	149.9-187.4	<b>39.6-49.5</b>
789D 2100 HP <sup>5</sup>	79.7-119.5	<b>21.1-31.6</b>	119.5-159.3	<b>31.6-42.1</b>	159.3-199.1	<b>42.1-52.6</b>
793D 2160 HP <sup>4</sup>	82.2-123.3	<b>21.7-32.6</b>	123.3-164.4	<b>32.6-43.4</b>	164.4-205.5	<b>43.4-54.3</b>
793D 2270 HP <sup>4</sup>	86.0-129.0	<b>22.7-34.1</b>	129.0-172.0	<b>34.1-45.4</b>	172.0-215.0	<b>45.4-56.8</b>
793D 2415 HP <sup>4</sup>	90.8-136.2	<b>24.0-36.0</b>	136.2-181.6	<b>36.0-48.0</b>	181.6-227.0	<b>48.0-60.0</b>
793F 2270 HP <sup>4</sup>	82.4-123.7	<b>21.8-32.7</b>	123.7-164.9	<b>32.7-43.6</b>	164.9-206.1	<b>43.6-54.5</b>
793F 2270 HP <sup>5</sup>	87.2-130.8	<b>23.0-34.6</b>	130.8-174.4	<b>34.6-46.1</b>	174.4-218.0	<b>46.1-57.6</b>
793F 2650 HP <sup>4</sup>	95.0-142.5	<b>25.1-37.6</b>	142.5-190.0	<b>37.6-50.2</b>	190.0-237.6	<b>50.2-62.8</b>
793F 2650 HP <sup>5</sup>	96.8-145.2	<b>25.6-38.4</b>	145.2-193.6	<b>38.4-51.1</b>	193.6-242.0	<b>51.1-63.9</b>
794 AC 2750 HP <sup>4</sup>	99.9-149.9	<b>26.4-39.6</b>	151.9-199.9	<b>40.1-52.8</b>	199.9-249.9	<b>52.8-66.0</b>
794 AC 3100 HP <sup>4</sup>	111.5-167.3	<b>29.5-44.2</b>	169.5-223.0	<b>44.8-58.9</b>	223.0-278.8	<b>58.9-73.7</b>
794 AC 3500 HP <sup>4</sup>	126.4-189.7	<b>33.4-50.1</b>	192.2-252.9	<b>50.8-66.8</b>	252.9-316.1	<b>66.8-83.5</b>
794 AC 2750 HP <sup>5</sup>	100.5-150.7	<b>26.5-39.8</b>	152.7-200.9	<b>40.3-53.1</b>	200.9-251.2	<b>53.1-66.3</b>
794 AC 3100 HP <sup>5</sup>	112.8-169.1	<b>29.8-44.7</b>	171.4-225.5	<b>45.3-59.6</b>	225.5-281.9	<b>59.6-74.5</b>
794 AC 3500 HP <sup>5</sup>	126.1-189.2	<b>33.3-50.0</b>	191.7-252.2	<b>50.6-66.6</b>	252.2-315.3	<b>66.6-83.3</b>
793F HAA 2650 HP <sup>4</sup>	90.7-136.0	<b>24.0-35.9</b>	136.0-181.4	<b>35.9-47.9</b>	181.4-226.7	<b>47.9-59.9</b>
795F 3100 HP <sup>4</sup>	113.0-169.5	<b>29.9-44.8</b>	169.5-226.1	<b>44.8-59.7</b>	226.1-282.6	<b>59.7-74.7</b>
795F 3100 HP <sup>5</sup>	113.1-169.7	<b>29.9-44.8</b>	169.7-226.3	<b>44.8-59.8</b>	226.3-282.8	<b>59.8-74.7</b>
795F 3400 HP <sup>4</sup>	124.4-186.6	<b>32.9-49.3</b>	186.6-248.8	<b>49.3-65.7</b>	248.8-311.0	<b>65.7-82.2</b>
795F 3400 HP <sup>5</sup>	124.4-186.6	<b>32.9-49.3</b>	186.6-248.8	<b>49.3-65.7</b>	248.8-311.0	<b>65.7-82.2</b>
795F HAA 3400 HP <sup>4</sup>	121.4-182.1	<b>32.1-48.1</b>	182.1-242.8	<b>48.1-64.1</b>	242.8-303.6	<b>64.1-80.2</b>
797B 3550 HP <sup>4</sup>	133.5-200.2	<b>35.3-52.9</b>	200.2-266.9	<b>52.9-70.5</b>	266.9-333.6	<b>70.5-88.1</b>
797F 3550 HP <sup>4</sup>	126.0-189.1	<b>33.3-50.0</b>	189.1-252.1	<b>50.0-66.6</b>	252.1-315.1	<b>66.6-83.2</b>
797F 3550 HP <sup>5</sup>	131.5-197.3	<b>34.7-52.1</b>	197.3-263.0	<b>52.1-69.5</b>	263.0-328.8	<b>69.5-86.9</b>
797F 4000 HP <sup>4</sup>	143.1-214.6	<b>37.8-56.7</b>	214.6-286.2	<b>56.7-75.6</b>	286.2-357.7	<b>75.6-94.5</b>
797F 4000 HP <sup>5</sup>	146.3-219.4	<b>38.7-58.0</b>	219.4-292.5	<b>58.0-77.3</b>	292.5-365.7	<b>77.3-96.6</b>
797F HAA 4000 HP <sup>5</sup>	147.9-221.8	<b>39.1-58.6</b>	221.8-295.8	<b>58.6-78.2</b>	295.8-369.7	<b>78.2-97.7</b>

Sea Level data only, power and fuel will change with altitude.

Value is product of load factor and rated power fuel burn, actual fuel burn will vary with engine speed and load.

It is recommended to use FPC (Fleet Productivity and Cost analysis) software for the best cycle and hourly fuel burn calculations.

HAA = High Altitude Engine Arrangement

<sup>1</sup> Machine requires the use of DEF with a consumption rate approximately 2-3% of diesel fuels.

<sup>2</sup> Fuel consumption based off machines reporting into VisionLink®.

<sup>3</sup> VisionLink fuel consumption not available by the time of publication, please consult the factory for information.

<sup>4</sup> Meets Tier 1 equivalent emission standards.

<sup>5</sup> Meets Tier 2 equivalent emission standards.

†Machine requires the use of DEF with a consumption rate approximately 2-3% of diesel fuel.

**Mining & Off-Highway Trucks**

**Typical Application Description**

(relative to work application)

- Low Continuous operation at an average gross weight less than recommended. Excellent haul roads. No overloading, low load factor.
- Medium Continuous operation at an average gross weight approaching recommended. Minimal overloading, good haul roads, moderate load factor.
- High Continuous operation at or above maximum recommended gross weight. Overloading, poor haul roads, high load factor.

**Load Factor Guide**

(average engine load factor based on application description for each range)

- Low 20%-30%
- Medium 30%-40%
- High 40%-50%

**NOTE:** For best results, use Caterpillar Fleet Production and Cost Analysis (FPC) to simulate cycle time, fuel burn, and production. For Application Specific Performance inquiries, contact Factory Representative or visit [catminer.cat.com/stb](http://catminer.cat.com/stb) for more information.

**ARTICULATED TRUCKS**

Model	Low		Medium		High	
	liter	U.S. gal	liter	U.S. gal	liter	U.S. gal
725 <sup>3</sup>	8.8-14.7	2.3-3.9	14.7-23.5	3.9-6.2	23.5-29.4	6.2-7.8
725C <sup>4</sup>	8.3-14.0	2.2-3.7	14.0-22.6	3.7-6.0	22.6-29.8	6.0-7.9
725C <sup>1</sup>	8.6-14.6	2.3-3.9	14.6-23.5	3.9-6.2	23.5-31.0	6.2-8.2
725C <sup>2</sup> <sup>4</sup>	8.3-14.0	2.2-3.7	14.0-22.6	3.7-6.0	22.6-29.8	6.0-7.9
725C <sup>2</sup> <sup>1</sup>	8.6-14.6	2.3-3.9	14.6-23.5	3.9-6.2	23.5-31.0	6.2-8.2
730 <sup>3</sup>	9.3-15.6	2.5-4.1	15.6-24.9	4.1-6.6	24.9-31.1	6.6-8.2
730C <sup>4</sup>	8.9-14.8	2.4-3.9	14.8-24.2	3.9-6.4	24.2-30.9	6.4-8.2
730C <sup>1</sup>	9.4-15.7	2.5-4.1	15.7-25.5	4.1-6.7	25.5-32.5	6.7-8.6
730C <sup>2</sup> <sup>4</sup>	8.9-14.8	2.4-3.9	14.8-24.2	3.9-6.4	24.2-30.9	6.4-8.2
730C <sup>2</sup> <sup>1</sup>	9.4-15.7	2.5-4.1	15.7-25.5	4.1-6.7	25.5-32.5	6.7-8.6
730 EJ <sup>3</sup>	10.0-14.6	2.6-3.9	14.6-24.8	3.9-6.6	24.8-30.0	6.6-7.9
730C EJ <sup>4</sup>	9.5-13.9	2.5-3.7	13.9-24.1	3.7-6.4	24.1-29.0	6.4-7.7
730C EJ <sup>1</sup>	10.0-14.7	2.6-3.9	14.7-25.4	3.9-6.7	25.4-31.2	6.7-8.2
730C <sup>2</sup> EJ <sup>4</sup>	9.5-13.9	2.5-3.7	13.9-24.1	3.7-6.4	24.1-29.0	6.4-7.7
730C <sup>2</sup> EJ <sup>1</sup>	10.0-14.7	2.6-3.9	14.7-25.4	3.9-6.7	25.4-31.2	6.7-8.2
735 <sup>3</sup>	12.4-20.7	3.3-5.5	20.7-33.2	5.5-8.8	33.2-41.5	8.8-11.0
735B <sup>4</sup>	11.5-19.1	3.0-5.0	19.1-30.5	5.0-8.1	30.5-38.2	8.1-10.1
735B <sup>2</sup>	12.4-20.7	3.3-5.5	20.7-33.2	5.5-8.8	33.2-41.5	8.8-11.0
735C <sup>4</sup>	11.5-19.1	3.0-5.0	19.1-30.5	5.0-8.1	30.5-38.2	8.1-10.1
735C <sup>1</sup>	12.2-20.2	3.2-5.3	20.2-32.4	5.3-8.6	32.4-40.5	8.6-10.7
740 <sup>3</sup>	13.5-22.5	3.6-6.0	22.5-36.1	6.0-9.5	36.1-45.1	9.5-11.9
740B <sup>4</sup>	12.2-20.3	3.2-5.4	20.3-32.5	5.4-8.6	32.5-40.6	8.6-10.7
740B <sup>2</sup>	13.5-22.5	3.6-6.0	22.5-36.1	6.0-9.5	36.1-45.1	9.5-11.9
740 EJ <sup>3</sup>	14.4-23.4	3.8-6.2	23.4-37.0	6.2-9.8	37.0-45.1	9.8-11.9
740B EJ <sup>4</sup>	12.2-20.3	3.2-5.4	20.3-32.5	5.4-8.6	32.5-40.6	8.6-10.7
740B EJ <sup>2</sup>	13.9-23.2	3.7-6.1	23.2-37.1	6.1-9.8	37.1-46.4	9.8-12.3
740C EJ <sup>4</sup>	12.5-20.8	3.3-5.5	20.8-33.3	5.5-8.8	33.3-41.6	8.8-11.0
740C EJ <sup>1</sup>	13.6-22.6	3.6-6.0	22.6-36.2	6.0-9.6	36.2-45.2	9.6-12.0
745C <sup>4</sup>	12.5-20.8	3.3-5.5	20.8-33.3	5.5-8.8	33.3-41.6	8.8-11.0
745C <sup>1</sup>	13.6-22.6	3.6-6.0	22.6-36.2	6.0-9.6	36.2-45.2	9.6-12.0

<sup>1</sup> Meets Tier 4 Final/Stage IV/Japan 2014 (Tier 4 Final) emission standards.

<sup>2</sup> Meets Tier 4 Interim/Stage IIIB/Japan 2011 (Tier 4 Interim) equivalent emission standards.

<sup>3</sup> Meets Tier 3/Stage IIIA/Japan 2006 (Tier 3) equivalent emission standards.

<sup>4</sup> Meets Tier 2/Stage II equivalent emission standards.

**Typical Application Description**

(relative to work application)

- Low Earthmoving and stockpile use with well matched loading equipment, free flowing material. Large amount of idling, short to medium haul distances on well-maintained level haul roads. Minimum total resistance, few impact loads.
- Medium Typical use in road-building, dam construction, open-pit mining, etc. Normal load and haul times, varying haul road conditions with some adverse grades. Some impact loads.
- High Poorly-matched loading equipment with continuous overloading. Long haul time and continuous use on very poorly maintained haul roads with frequent adverse grades. High rolling resistance, poor traction, high impact loads.

**Load Factor Guide**

(average engine load factor based on application description for each range)

- Low 15%-25%
- Medium 25%-40%
- High 40%-50%

**TELEHANDLERS**

Model	Low		Medium		High	
	liter	U.S. gal	liter	U.S. gal	liter	U.S. gal
TH210	5.1-6.8	1.3-1.8	8.5-10.1	2.2-2.6	11.8-13.5	3.1-3.5
TH215	5.1-6.8	1.3-1.8	8.5-10.1	2.2-2.6	11.8-13.5	3.1-3.5
TH220B (59-74 kW/80-99 hp)	5.0-7.0	1.3-1.8	10.0-14.0	2.6-3.7	13.0-17.0	3.4-4.5
TH220B (92 kW/123 hp)	5.0-8.0	1.3-2.1	10.0-16.0	2.6-4.2	13.0-20.0	3.4-5.3
TH330B (59-74 kW/80-99 hp)	5.0-7.0	1.3-1.8	10.0-14.0	2.6-3.7	13.0-17.0	3.4-4.5
TH330B (92 kW/123 hp)	5.0-8.0	1.3-2.1	10.0-16.0	2.6-4.2	13.0-20.0	3.4-5.3
TH340B	5.0-7.0	1.3-1.8	10.0-14.0	2.6-3.7	13.0-17.0	3.4-4.5
TH350B	5.0-7.0	1.3-1.8	10.0-14.0	2.6-3.7	13.0-17.0	3.4-4.5
TH355B	5.0-7.0	1.3-1.8	10.0-14.0	2.6-3.7	13.0-17.0	3.4-4.5
TH360B	5.0-7.0	1.3-1.8	10.0-14.0	2.6-3.7	13.0-17.0	3.4-4.5
TH460B	5.0-7.0	1.3-1.8	10.0-14.0	2.6-3.7	13.0-17.0	3.4-4.5
TH560B (59-74 kW/80-99 hp)	5.0-9.0	1.3-2.4	10.0-15.0	2.6-4.0	13.0-17.5	3.4-4.6
TH560B (92 kW/123 hp)	5.0-9.0	1.3-2.4	10.0-17.0	2.6-4.5	13.0-21.0	3.4-5.5
TH580B	5.0-6.0	1.3-1.6	9.0-10.7	2.4-2.8	16.0-18.3	4.2-4.8

**Typical Application Description**

(relative to work application)

Low Light to moderate, intermittent, utility applications with frequent periods of idling and limited travel.

Medium General construction applications with moderate amounts of travel.

High Continuous production applications with near capacity loading and extended lifts.

**Load Factor Guide**

(average engine load factor based on application description for each range)

Low 20%-30%

Medium 30%-40%

High 40%-50%

**WHEEL DOZERS/SOIL COMPACTORS/LANDFILL COMPACTORS**

Model	Low		Medium		High	
	liter	U.S. gal	liter	U.S. gal	liter	U.S. gal
814F	21.0-25.0	5.5-6.5	26.0-30.0	7.0-8.0	36.0-40.0	9.5-10.5
815K	26.0-30.0	7.0-8.0	36.0-42.0	9.5-11.0	44.0-47.0	11.5-12.5
816F	26.0-30.0	7.0-8.0	36.0-42.0	9.5-11.0	44.0-47.0	11.5-12.5
824K	28.9-33.8	7.9-8.9	39.8-45.8	10.5-12.1	53.7-59.7	14.2-15.8
825K	37.8-43.8	10.0-11.6	53.7-67.3	14.2-17.8	63.7-69.7	16.8-18.4
826K	34.0-35.8	8.4-9.4	39.8-43.8	10.5-11.6	47.8-51.7	12.6-13.6
834K	34.6-43.4	9.1-11.4	48.2-52.2	12.7-13.8	67.6-74.0	17.8-19.5
836H	39.8-43.8	10.5-11.6	47.8-51.7	12.6-14.0	55.7-59.7	14.7-18.0
844K	42.0-50.0	11.0-13.0	54.0-62.0	14.0-16.0	65.0-73.0	17.0-19.0
854K	49.2-64.4	13.0-17.0	64.4-79.5	17.0-21.0	79.5-94.6	21.0-25.0

**Wheel Dozers**

**Typical Application Description**

(relative to work application)

Low Light utility and stockpile work. Pulling compactors. Dozing loose fill. Considerable idling or travel with no load and no impact.

Medium Production dozing, push loading in clays, sands, silts, loose gravels. Shovel clean-up. Normal compaction.

High Heavy production dozing in rock. Push-loading in rocky, bouldery borrow pits. Heavy landfill compactor work. High impact conditions.

**Load Factor Guide**

(average engine load factor based on application description for each range)

Low 35%-50%

Medium 50%-65%

High 65%-80%

**Soil Compactors/Landfill Compactors**

**Typical Application Description**

(relative to work application)

Low No dozing or very light spreading on a flat or downhill surface. Machine has support equipment dozing and spreading trash while compactor simply travels over flat surface multiple times.

Medium Compactor primary use is compacting already spread material. Compactor assists in dozing and spreading during peak periods of day and possibly working slopes of no steeper than a 4:1.

High Compactor is possibly only machine for operation. Machine will doze and spread material alone and then compact it with multiple passes working on steep slopes and possibly uphill.

**Load Factor Guide**

(average engine load factor based on application description for each range)

Low 35%-50%

Medium 50%-65%

High 65%-80%



**COMPACTION EQUIPMENT**

Model	Low		Medium		High	
	liter	U.S. gal	liter	U.S. gal	liter	U.S. gal
<b>SOIL COMPACTORS</b>						
CS-323C	8.0-13.0	<b>2.0-3.5</b>	11.0-15.0	<b>3.0-4.0</b>	11.0-19.0	<b>3.0-5.0</b>
CS34	4.9-6.1	<b>1.3-1.6</b>	6.1-9.1	<b>1.6-2.4</b>	9.1-12.9	<b>2.4-3.4</b>
CP-323C	8.0-13.0	<b>2.0-3.5</b>	11.0-15.0	<b>3.0-4.0</b>	11.0-19.0	<b>3.0-5.0</b>
CP34	4.9-6.1	<b>1.3-1.6</b>	6.1-9.1	<b>1.6-2.4</b>	9.1-12.9	<b>2.4-3.4</b>
CS-423E	4.5-6.4	<b>1.2-1.7</b>	6.4-9.5	<b>1.7-2.5</b>	9.5-12.9	<b>2.5-3.4</b>
CS-533E	5.7-9.5	<b>1.5-2.5</b>	9.5-13.2	<b>2.5-3.5</b>	13.2-17.0	<b>3.5-4.5</b>
CP-533E	5.7-9.5	<b>1.5-2.5</b>	9.5-13.2	<b>2.5-3.5</b>	13.2-17.0	<b>3.5-4.5</b>
CS44	5.8-7.8	<b>1.5-2.1</b>	7.8-11.9	<b>2.1-3.1</b>	11.9-15.7	<b>3.1-4.2</b>
CS44B	6.1-7.2	<b>1.6-1.9</b>	7.2-11.0	<b>1.9-2.9</b>	11.0-15.5	<b>2.9-4.1</b>
CP44	5.8-7.8	<b>1.5-2.1</b>	7.8-11.9	<b>2.1-3.1</b>	11.9-15.7	<b>3.1-4.2</b>
CP44B	6.1-7.2	<b>1.6-1.9</b>	7.2-11.0	<b>1.9-2.9</b>	11.0-15.5	<b>2.9-4.1</b>
CS54	5.7-9.5	<b>1.5-2.5</b>	9.5-13.2	<b>2.5-3.5</b>	13.2-17.0	<b>3.5-4.5</b>
CS56	7.6-9.5	<b>2.0-2.5</b>	9.5-15.1	<b>2.5-4.0</b>	15.1-22.7	<b>4.0-6.0</b>
CP56	7.6-9.5	<b>2.0-2.5</b>	9.5-15.1	<b>2.5-4.0</b>	15.1-22.7	<b>4.0-6.0</b>
CS64	7.6-9.5	<b>2.0-2.5</b>	9.5-15.1	<b>2.5-4.0</b>	15.1-26.5	<b>4.0-7.0</b>
CP64	7.6-9.5	<b>2.0-2.5</b>	9.5-15.1	<b>2.5-4.0</b>	15.1-26.5	<b>4.0-7.0</b>
CS74	9.5-11.4	<b>2.5-3.0</b>	11.4-15.1	<b>3.0-4.0</b>	15.1-26.5	<b>4.0-7.0</b>
CP74	9.5-11.4	<b>2.5-3.0</b>	11.4-15.1	<b>3.0-4.0</b>	15.1-26.5	<b>4.0-7.0</b>
CS76	11.4-13.3	<b>3.0-3.5</b>	13.3-17.0	<b>3.5-4.5</b>	17.0-26.5	<b>4.5-7.0</b>
CP76	11.4-13.3	<b>3.0-3.5</b>	13.3-17.0	<b>3.5-4.5</b>	17.0-26.5	<b>4.5-7.0</b>
CS76 XT	11.4-13.3	<b>3.0-3.5</b>	13.3-17.0	<b>3.5-4.5</b>	17.0-26.5	<b>4.5-7.0</b>
CS54B	6.3-10.5	<b>1.7-2.8</b>	10.5-14.5	<b>2.8-3.9</b>	14.5-18.7	<b>3.9-5.0</b>
CP54B	6.3-10.5	<b>1.7-2.8</b>	10.5-14.5	<b>2.8-3.9</b>	14.5-18.7	<b>3.9-5.0</b>
CS56B	8.4-10.5	<b>2.2-2.8</b>	10.5-16.6	<b>2.8-4.4</b>	16.6-25.0	<b>4.4-6.6</b>
CP56B	8.4-10.5	<b>2.2-2.8</b>	10.5-16.6	<b>2.8-4.4</b>	16.6-25.0	<b>4.4-6.6</b>
CS64B	6.3-10.5	<b>1.7-2.8</b>	10.5-14.5	<b>2.8-3.9</b>	14.5-18.7	<b>3.9-5.0</b>
CS66B	8.4-10.5	<b>2.2-2.8</b>	10.5-16.6	<b>2.8-4.4</b>	16.6-25.0	<b>4.4-6.6</b>
CS68B	8.4-10.5	<b>2.2-2.8</b>	10.5-16.6	<b>2.8-4.4</b>	16.6-29.2	<b>4.4-7.7</b>
CP68B	8.4-10.5	<b>2.2-2.8</b>	10.5-16.6	<b>2.8-4.4</b>	16.6-29.2	<b>4.4-7.7</b>
CS74B	10.5-12.5	<b>2.8-3.3</b>	12.5-16.6	<b>3.3-4.4</b>	16.6-29.2	<b>4.4-7.7</b>
CP74B	10.5-12.5	<b>2.8-3.3</b>	12.5-16.6	<b>3.3-4.4</b>	16.6-29.2	<b>4.4-7.7</b>
CS76B	12.5-14.9	<b>3.3-3.9</b>	14.9-18.7	<b>3.9-5.0</b>	18.7-29.2	<b>5.0-7.7</b>
CS78B	12.5-14.9	<b>3.3-3.9</b>	14.9-18.7	<b>3.9-5.0</b>	18.7-29.2	<b>5.0-7.7</b>
CS79B	12.5-14.9	<b>3.3-3.9</b>	14.9-18.7	<b>3.9-5.0</b>	18.7-29.2	<b>5.0-7.7</b>

**COMPACTION EQUIPMENT**

Model	Low		Medium		High	
	liter	U.S. gal	liter	U.S. gal	liter	U.S. gal
<b>ASPHALT COMPACTORS</b>						
CB-434D	5.7-7.6	1.5-2.0	7.6-11.4	2.0-3.0	11.4-15.2	3.0-4.0
CB-534D	5.7-7.6	1.5-2.0	7.6-11.4	2.0-3.0	11.4-15.2	3.0-4.0
CB-534D XW	5.7-7.6	1.5-2.0	7.6-11.4	2.0-3.0	11.4-15.2	3.0-4.0
CB-564D	8.6	2.3	10.4	2.8	13.3	3.5
CB54	8.5	2.2	9.4	2.5	11.0	2.9
CB54 XW	8.2	2.2	9.4	2.5	11.0	2.9
CB64	8.5	2.2	9.4	2.5	12.9	3.4
CB44B*	6.8	1.8	8.3	2.2	10.2	2.7
CD44B*	6.8	1.8	8.3	2.2	10.2	2.7
CB54B*	7.9	2.1	9.5	2.5	10.9	2.9
CD54B*	6.8	1.8	8.3	2.2	10.2	2.7
CB64B*	8.2	2.2	9.4	2.5	11.0	2.9
CB66B*	8.5	2.2	9.4	2.5	12.9	3.4
CB68B*	8.5	2.2	9.4	2.5	12.9	3.4
<b>PNEUMATIC TIRED COMPACTORS</b>						
PS-150C	8.0-11.0	2.0-3.0	11.0-13.0	3.0-3.5	13.0-15.0	3.5-4.0
PS-300C	13.0-15.0	3.5-4.0	15.0-17.0	4.0-4.5	17.0-23.0	4.5-6.0
PF-300C	13.0-15.0	3.5-4.0	15.0-17.0	4.0-4.5	17.0-23.0	4.5-6.0
PS-360C	7.4-9.8	1.9-2.6	9.8-12.4	2.6-3.3	12.4-14.5	3.3-4.6
CW14	8.0-11.0	2.1-2.9	11.0-13.0	2.9-3.4	13.0-15.0	3.4-4.0
CW16	8.0-11.0	2.1-2.9	11.0-13.0	2.9-3.4	13.0-15.0	3.4-4.0
CW34	7.4-9.8	2.0-2.6	9.8-12.4	2.6-3.3	12.4-14.5	3.3-3.8

\*Eco-mode use provides up to 10% less fuel consumption depending upon job site conditions.

**Asphalt Compactors**

**Typical Application Description**

(relative to work application)

Low Asphalt mix, 25-50 mm (**1-2 inch**) lifts. Static finish rolling, all lifts.

Medium Asphalt mix, 51-100 mm (**2-4 inch**) lifts.

High Asphalt mix, 101-150 mm (**4-6 inch**) lifts. Prepare granular base lifts.

**Vibratory Soil Compactors**

**Typical Application Description**

(relative to work application)

Low Granular soil not compacted to high density (<95 Proctor). Residential street work with lift thicknesses up to 150 mm (**6 inch**) working the initial compaction. Level ground, minimal slopes and intermittent periods of waiting for base work completion or material delivery. Speeds in the middle of the low range (2-3 km/h [**1-2 mph**]). Minimal start and stop of the vibrate function.

Medium Granular soil compacted to density (>95 Proctor). Cohesive soils with padded drum and low/normal moisture content, blading <25%. Continuous operation on thicker lifts 150-350 mm (**6-14 inch**) or doing the final passes on stiffer materials or working at the top end of the low speed range. Working on slopes greater than 5% or rapid directional changes combined with start and stop of the vibrate function.

High Cohesive soil with padded drum and high moisture content. Combined high load factors from the medium duty application. Working on thick lifts greater than 350 mm (**14 inch**), slopes greater than 15%, or applications requiring significant blade work. An example would be trench work with backfilling.

**Load Factor Guide**

(average engine load factor based on application description for each range)

Low Vibration 20-40%

Medium Vibration 40-60%

High Vibration 60-100%

**Pneumatic Compactors**

**Typical Application Description**

(relative to work application)

Low Asphalt mix, all lifts. Intermediate or finish rolling, chip seal. Level ground.

Medium Asphalt mix, all lifts. Intermediate or finish rolling. Granular base breakdown <100 mm (**<4 inch**). Moderate grade.

High Granular base or cold in place breakdown roller >100 mm (**4 inch**) lifts. Intermediate or finish rolling. Steep grades.

**Load Factor Guide**

(average engine load factor based on application description for each range)

Low Vibration 30%-50%

Medium Vibration 50%-80%

High Vibration 80%-100%

**COMPACTION EQUIPMENT — UTILITY COMPACTORS**

Model	Low		Medium		High	
	liter	U.S. gal	liter	U.S. gal	liter	U.S. gal
CB14B, CB14B XW	1.5	0.4	1.9	0.5	2.2	0.58
CB22	4.0	1.06	5.5	1.45	7.0	1.85
CB22B*	4.0	1.06	5.5	1.45	7.0	1.85
CB24, CB24 XT	4.0	1.06	5.5	1.45	7.0	1.85
CB24B, CB24B XT*	4.0	1.06	5.5	1.45	7.0	1.85
CC24	3.0	0.79	5.0	1.32	7.0	1.85
CC24B*	3.0	0.79	5.0	1.32	7.0	1.85
CB32	4.0	1.06	5.5	1.45	7.0	1.85
CB32B*	4.0	1.06	5.5	1.45	7.0	1.85
CB34, CB34 XW	2.0-3.2	0.53-0.83	3.2-4.5	0.83-1.19	4.5-6.0	1.19-1.59
CB34B, CB36B*	2.0-3.2	0.53-0.83	3.2-4.5	0.83-1.19	4.5-6.0	1.19-1.59
CC34	2.0-3.2	0.53-0.83	3.2-4.5	0.83-1.19	4.5-6.0	1.19-1.59
CC34B*	2.0-3.2	0.53-0.83	3.2-4.5	0.83-1.19	4.5-6.0	1.19-1.59

\*Eco-mode use provides up to 8% less fuel consumption depending on job site conditions.

**Utility Compactors — CB14, CB22, CB24, CB32, CC24**

**Typical Application Description**

(relative to work application)

- Low Asphalt mix, 25-50 mm (1-2 inch) lifts. Static finish rolling, all lifts.
- Medium Asphalt mix, 25-50 mm (1-2 inch) lifts. Normal working conditions with vibrate and static.
- High Asphalt mix, 25-50 mm (1-2 inch) lifts. May include some soil compaction.

**Load Factor Guide**

(average engine load factor based on application description for each range)

- Low Vibration 10-30%
- Medium Vibration 30-60%
- High Vibration 60-85%

**Utility Compactors — CB34, CC34, CB36**

**Typical Application Description**

(relative to work application)

- Low Asphalt mix, 25-50 mm (1-2 inch) lifts. Static finish rolling, all lifts.
- Medium Asphalt mix, 51-100 mm (2-4 inch) lifts.
- High Asphalt mix, 101-150 mm (4-6 inch) lifts. Prepare granular base lifts.

**Load Factor Guide**

(average engine load factor based on application description for each range)

- Low Vibration 20-40%
- Medium Vibration 40-70%
- High Vibration 80-100%

- Asphalt Pavers
- Cold Planers

**ASPHALT PAVERS**

Model	Low		Medium		High	
	liter	U.S. gal	liter	U.S. gal	liter	U.S. gal
AP500F (106 kW/ <b>142 hp</b> )	7.6-9.5	<b>2.0-2.5</b>	9.5-11.4	<b>2.5-3.0</b>	11.4-15.1	<b>3.0-4.0</b>
AP555F (106 kW/ <b>142 hp</b> )	7.6-9.5	<b>2.0-2.5</b>	9.5-11.4	<b>2.5-3.0</b>	11.4-15.1	<b>3.0-4.0</b>
AP600F (129 kW/ <b>173 hp</b> )	7.6-11.4	<b>2.0-3.0</b>	11.4-17.0	<b>3.0-4.5</b>	17.0-22.7	<b>4.5-6.0</b>
AP655F (129 kW/ <b>173 hp</b> )	7.6-11.4	<b>2.0-3.0</b>	11.4-17.0	<b>3.0-4.5</b>	17.0-24.6	<b>4.5-6.5</b>
AP1000F (168 kW/ <b>225 hp</b> )	9.5-15.1	<b>2.5-4.0</b>	15.1-18.9	<b>4.0-5.0</b>	18.9-24.6	<b>5.0-6.5</b>
AP1055F (168 kW/ <b>225 hp</b> )	9.5-15.1	<b>2.5-4.0</b>	15.1-18.9	<b>4.0-5.0</b>	18.9-26.5	<b>5.0-7.0</b>

NOTE: The above fuel usage rates assume typical idle times for screed warm up and machine clean up.

**Typical Application Description**

(relative to work application)

Low Narrow width paving, low production.

Medium 3-4 m (**10-12 feet**) width, 50-75 mm (**2-3 inch**) lift.

High Wide width, deep lift paving.

**Load Factor Guide**

(average engine load factor based on application description for each range)

Low 20%-30%

Medium 30%-40%

High 40%-50%

**COLD PLANERS**

Model	Low		Medium		High	
	liter	U.S. gal	liter	U.S. gal	liter	U.S. gal
PM102	15.6-22.3	<b>4.1-5.9</b>	22.3-29.0	<b>5.9-7.7</b>	29.0-35.7	<b>7.7-9.4</b>
PM200	38.7-55.3	<b>10.2-14.6</b>	55.3-71.8	<b>14.6-19.0</b>	71.8-88.4	<b>19.0-23.4</b>
PM201	45.5-60.6	<b>12.0-16.0</b>	60.6-83.4	<b>16.0-22.0</b>	83.4-106.1	<b>22.0-28.0</b>
PM620	42.0-56.0	<b>11.1-14.8</b>	56.0-76.0	<b>14.8-20.1</b>	76.0-100.0	<b>20.1-26.4</b>
PM622	42.0-56.0	<b>11.1-14.8</b>	56.0-76.0	<b>14.8-20.1</b>	76.0-100.0	<b>20.1-26.4</b>

**Typical Application Description**

(relative to work application)

Low 50 mm (**2 inches**) or less cutting depth, 80% load cycle.

Medium 100 mm (**4 inches**) cutting depth.

High Steady, full depth.

**Load Factor Guide**

(average engine load factor based on application description for each range)

Low 35%-50%

Medium 50%-65%

High 65%-80%

**ROAD RECLAIMERS/SOIL STABILIZERS**

Model	Low		Medium		High	
	liter	U.S. gal	liter	U.S. gal	liter	U.S. gal
RM300	26.5-34.1	7.0-9.0	34.1-41.6	9.0-11.0	41.6-53.0	11.0-14.0
RM350B	53.1-68.2	14.0-18.0	68.2-83.4	18.0-22.0	83.4-94.8	22.0-25.0
RM500	45.4-56.7	12.0-15.0	60.5-68.1	16.0-18.0	75.7-87.1	20.0-23.0
RM500B	48.6-80.2	12.8-21.2	68.1-97.7	18.0-25.8	85.4-106.9	22.6-28.2

**Typical Application Description**

(relative to work application)

Low 150 mm (6 inches) soil/100 mm (4 inches) asphalt.

Medium 305 mm (12 inches) soil/150 mm (6 inches) asphalt.

High 457 mm (18 inches) soil/305 mm (12 inches) asphalt.

**Load Factor Guide**

(average engine load factor based on application description for each range)

Low 35%-60%

Medium 60%-80%

High 80%-90%

**TRACK LOADERS**

Model	Low		Medium		High	
	liter	U.S. gal	liter	U.S. gal	liter	U.S. gal
953D <sup>2</sup>	6.5-11.6	1.7-3.1	11.6-16.7	3.1-4.4	16.7-21.7	4.4-5.7
953K <sup>1</sup>	6.0-10.4	1.6-2.7	10.4-15.2	2.7-4.0	15.2-20.5	4.0-5.4
963D <sup>2</sup>	8.5-15.0	2.2-4.0	15.0-22.5	4.0-5.9	22.5-30.5	5.9-8.1
963K <sup>1</sup>	6.5-13.0	1.7-3.4	13.0-20.5	3.4-5.4	20.5-28.0	5.4-7.4
973D <sup>2</sup>	10.0-19.2	2.6-5.1	19.2-30.6	5.1-8.1	30.6-42.0	8.1-11.1

<sup>1</sup> Meets Tier 4 Final/Stage IV/Japan 2014 (Tier 4 Final) emission standards — Calculations include DEF.

<sup>2</sup> Meets Tier 3/Stage IIIA/Japan 2006 (Tier 3) equivalent emission standards.

**Typical Application Description**

(relative to work application)

Low Site clearing of small vegetation, stripping top soil, carrying to stockpile. Backfilling and grading. Intermittent truck loading from stockpile. Free flowing, low density materials with standard bucket. Large amounts of idling.

Medium Bank excavation, bank or stockpile loading. Intermittent ripping, basement digging of natural bed clays, sands, silts, gravels. Load and carry. Steady full throttle operation.

High Loading shot rock, cobbles, glacial till, caliche. Continuous work on rock surfaces. Continuous excavating and loading from bank. High density materials in standard bucket. Land clearing, large amount of ripping in tight, rocky materials. Waste application and transfer station.

**Load Factor Guide**

(average engine load factor based on application description for each range)

Low 20%-30%

Medium 30%-45%

High 45%-65%

**WHEEL LOADERS AND INTEGRATED TOOLCARRIERS**

Model	Low		Medium		High	
	liter	U.S. gal	liter	U.S. gal	liter	U.S. gal
901C2 (Japan Only) <sup>1</sup>	0.0-1.5	<b>0.0-0.4</b>	1.5-3.4	<b>0.4-0.9</b>	3.4-4.9	<b>0.9-1.3</b>
902C2 (Japan Only), 903C2 <sup>1</sup>	0.0-2.3	<b>0.0-0.6</b>	2.3-4.5	<b>0.6-1.2</b>	4.5-6.8	<b>1.2-1.8</b>
906K <sup>3</sup>	2.3-3.8	<b>0.6-1.0</b>	3.8-5.7	<b>1.0-1.5</b>	5.7-9.5	<b>1.5-2.5</b>
906M <sup>1</sup>	2.3-3.8	<b>0.6-1.0</b>	3.8-5.7	<b>1.0-1.5</b>	5.7-9.5	<b>1.5-2.5</b>
907K <sup>3</sup>	2.3-3.8	<b>0.6-1.0</b>	3.8-5.7	<b>1.0-1.5</b>	5.7-9.5	<b>1.5-2.5</b>
907M <sup>1</sup>	2.3-3.8	<b>0.6-1.0</b>	3.8-5.7	<b>1.0-1.5</b>	5.7-9.5	<b>1.5-2.5</b>
908K <sup>3</sup>	2.3-3.8	<b>0.6-1.0</b>	3.8-5.7	<b>1.0-1.5</b>	5.7-9.5	<b>1.5-2.5</b>
908M <sup>1</sup>	2.3-3.8	<b>0.6-1.0</b>	3.8-5.7	<b>1.0-1.5</b>	5.7-9.5	<b>1.5-2.5</b>
910K <sup>4</sup>	3.4-6.0	<b>0.9-1.6</b>	6.0-7.6	<b>1.6-2.0</b>	7.6-11.4	<b>2.0-3.0</b>
910M <sup>2</sup>	3.4-6.0	<b>0.9-1.6</b>	6.0-7.6	<b>1.6-2.0</b>	7.6-11.4	<b>2.0-3.0</b>
914K <sup>4</sup>	3.4-6.0	<b>0.9-1.6</b>	6.0-7.6	<b>1.6-2.0</b>	7.6-11.4	<b>2.0-3.0</b>
914M <sup>2</sup>	3.4-6.0	<b>0.9-1.6</b>	6.0-7.6	<b>1.6-2.0</b>	7.6-11.4	<b>2.0-3.0</b>
918M <sup>2</sup>	3.4-6.0	<b>0.9-1.6</b>	6.0-7.6	<b>1.6-2.0</b>	7.6-11.4	<b>2.0-3.0</b>
924K	3.3-9.7	<b>0.9-2.6</b>	8.1-14.5	<b>2.1-3.8</b>	12.9-19.3	<b>3.4-5.1</b>
926M	3.3-5.6	<b>0.9-1.5</b>	5.2-8.5	<b>1.4-2.2</b>	8.1-11.2	<b>2.1-3.0</b>
930K	3.3-8.1	<b>0.9-2.1</b>	6.9-11.7	<b>1.8-3.1</b>	10.5-15.3	<b>2.8-4.1</b>
930M	3.4-5.9	<b>0.9-1.6</b>	5.5-8.8	<b>1.5-2.3</b>	8.6-11.9	<b>2.3-3.1</b>
938K	2.9-7.1	<b>0.8-1.9</b>	6.1-10.3	<b>1.6-2.7</b>	9.3-13.5	<b>2.5-3.6</b>
938M	3.4-5.9	<b>0.9-1.6</b>	5.6-8.9	<b>1.5-2.4</b>	8.6-11.9	<b>2.3-3.1</b>

<sup>1</sup> Meets Tier 4 Final/Stage IIIB/Japan 2014 (Tier 4 Final) emission standards.

<sup>2</sup> Meets Tier 4 Final/Stage IV/Japan 2014 (Tier 4 Final) emission standards.

<sup>3</sup> Meets Tier 4 Interim/Stage IIIA or Tier 2/Stage II equivalent emission standards.

<sup>4</sup> Meets Tier 3/Stage IIIA equivalent emission standards.

**WHEEL LOADERS AND INTEGRATED TOOLCARRIERS**

Model	Low		Medium		High	
	liter	U.S. gal	liter	U.S. gal	liter	U.S. gal
950 GC <sup>1</sup>	7.5-10.1	<b>2.0-2.7</b>	10.1-13.2	<b>2.7-3.5</b>	13.2-17.6	<b>3.5-4.7</b>
950H <sup>1</sup>	8.2-11.7	<b>2.2-3.1</b>	11.7-14.8	<b>3.1-3.9</b>	14.8-18.4	<b>3.9-4.9</b>
950K <sup>1</sup>	8.0-10.9	<b>2.1-2.9</b>	10.9-13.4	<b>2.9-3.5</b>	13.4-16.6	<b>3.5-4.4</b>
950M <sup>1,2,3</sup>	7.6-10.4	<b>2.0-2.8</b>	10.4-12.8	<b>2.8-3.4</b>	12.8-15.7	<b>3.4-4.1</b>
962H, IT62H <sup>1</sup>	7.8-12.0	<b>2.1-3.2</b>	12.0-15.1	<b>3.2-4.0</b>	15.1-18.5	<b>4.0-4.9</b>
962K <sup>1</sup>	8.8-11.1	<b>2.3-2.9</b>	11.1-13.7	<b>2.9-3.6</b>	13.7-16.8	<b>3.6-4.4</b>
962M <sup>1,2,3</sup>	7.9-10.9	<b>2.1-2.9</b>	10.9-13.5	<b>2.9-3.6</b>	13.5-15.9	<b>3.6-4.2</b>
966H <sup>1</sup>	9.0-13.2	<b>2.4-3.5</b>	13.2-16.8	<b>3.5-4.4</b>	16.8-20.6	<b>4.4-5.4</b>
966K <sup>1</sup>	10.8-14.9	<b>2.8-3.9</b>	14.9-18.0	<b>3.9-4.7</b>	18.0-23.1	<b>4.7-6.1</b>
966M <sup>1,2,3</sup>	8.9-12.6	<b>2.3-3.3</b>	12.6-15.7	<b>3.3-4.2</b>	15.7-19.0	<b>4.2-5.0</b>
966M XE <sup>1,2</sup>	9.2-11.5	<b>2.4-3.0</b>	11.5-13.6	<b>3.0-3.6</b>	13.6-16.2	<b>3.6-4.3</b>
972H <sup>1</sup>	11.3-17.0	<b>3.0-4.5</b>	17.0-20.7	<b>4.5-5.5</b>	20.7-24.7	<b>5.5-6.5</b>
972K <sup>1</sup>	12.5-15.8	<b>3.3-4.2</b>	15.8-19.6	<b>4.2-5.2</b>	19.6-24.3	<b>5.2-6.4</b>
972M <sup>1,2,3</sup>	10.5-14.1	<b>2.8-3.7</b>	14.1-17.4	<b>3.7-4.6</b>	17.4-21.4	<b>4.6-5.7</b>
972M XE <sup>1,2</sup>	10.6-12.7	<b>2.8-3.3</b>	12.7-15.0	<b>3.3-4.0</b>	15.0-18.0	<b>4.0-4.7</b>
980H <sup>1</sup>	14.9-21.0	<b>3.9-5.5</b>	21.0-26.4	<b>5.5-7.0</b>	26.4-32.5	<b>7.0-8.6</b>
980K <sup>1</sup>	14.9-19.5	<b>3.9-5.1</b>	19.5-23.8	<b>5.1-6.3</b>	23.8-29.3	<b>6.3-7.7</b>
980M <sup>1,2,3</sup>	14.0-18.4	<b>3.7-4.9</b>	18.4-23.0	<b>4.9-6.1</b>	23.0-29.2	<b>6.1-7.7</b>
982M <sup>1,2,3</sup>	15.6-20.3	<b>4.1-5.4</b>	20.3-25.4	<b>5.4-6.7</b>	25.4-31.9	<b>6.7-8.4</b>
986H <sup>1</sup>	19.0-27.3	<b>5.0-7.2</b>	27.3-35.8	<b>7.2-9.5</b>	35.8-44.3	<b>9.5-11.7</b>
988K <sup>1</sup>	23.8-34.1	<b>6.3-9.0</b>	34.1-44.7	<b>9.0-11.8</b>	44.7-55.3	<b>11.8-14.6</b>
990H <sup>1</sup>	42.0-58.3	<b>11.1-15.4</b>	58.3-75.0	<b>15.4-19.8</b>	75.0-91.6	<b>19.8-24.2</b>
992K <sup>1</sup>	53.0-75.7	<b>14.0-20.0</b>	75.7-98.4	<b>20.0-26.0</b>	98.4-121.0	<b>26.0-32.0</b>
993K <sup>1</sup>	61.3-87.4	<b>16.2-23.1</b>	87.4-113.6	<b>23.1-30.3</b>	113.6-140.0	<b>30.0-37.0</b>
994K <sup>1</sup>	96.1-135.9	<b>25.4-35.9</b>	135.9-176.8	<b>35.9-46.9</b>	176.8-217.7	<b>46.9-57.5</b>

<sup>1</sup> The Medium Wheel Loader (i.e. 950 through 982) and Large Wheel Loader (i.e. 986 through 994) hourly fuel rates are taken directly from customer machines registered on Product Link worldwide. Data from the top and bottom 5% of these customer machines has been excluded from the tables because it varies widely (15-60% from the extremes shown) and therefore is not considered representative of what the remaining 90% of customers experience. Hourly fuel consumption for the 90% of machines in the tables also varies depending upon geographical region, load factor variation between units, etc. Cat machines are often used in more demanding applications which can account for differences between competitive models used in lighter duty applications. Consult your local Cat dealer for ways to more accurately estimate hourly fuel consumption for specific applications.

<sup>2</sup> Machines that meet Tier 4 Final/Stage IV/Japan 2014 (Tier 4 Final) emission standards require the use of DEF with a consumption rate approximately 2-3% of diesel fuel.

<sup>3</sup> These hourly fuel rates reflect the actual field population which includes a mix of machines operating with Economy Mode ON and machines operating with Economy Mode OFF. It has been demonstrated that operating in a typical application with Economy Mode ON can deliver 8% lower fuel consumption.

**NOTE:** Medium Wheel Loaders

Machines are not available in all regions. Contact your local Cat dealer for product availability.



**Compact Wheel Loaders**

**Typical Application Description**

(relative to work application)

- Low Light industrial or construction site duties. Moving light loads with bucket or pallet forks. Not continuous duty, considerable idle time. Machine could be working on average 2 hours or less per day.
- Medium Intermittent aggregate truck loading from stockpile, hopper charging or load and carry on firm, smooth surfaces for short distances with minimal grades. Free flowing, low density materials. Light utility, industrial and construction applications. Light snowplowing.
- High Continuous truck loading from stockpile and hopper charging. Loading from bank or load and carry on normal surfaces with low to medium rolling resistance and slight adverse grades. Low to medium density materials in properly sized bucket. Assumes normal travel distances associated with high productivity stockpile load-out and batch plant applications.

**Load Factor Guide**

(percent of available horsepower required for each work application)

- Low 0%-25%
- Medium 25%-50%
- High 50%-75%

**Small, Medium and Large Wheel Loaders and Integrated Toolcarriers**

**Typical Application Description**

(relative to work application)

- Low Intermittent aggregate truck loading from stockpile, hopper charging or load and carry on firm, smooth surfaces for short distances with minimal grades. Free flowing, low density materials. Light utility, industrial and construction applications. Light snowplowing. Most logging applications where there is considerable idling.
- Medium Continuous truck loading from stockpile and hopper charging. Loading from bank or load and carry on normal surfaces with low to medium rolling resistance and slight adverse grades. Low to medium density materials in properly sized bucket. Assumes normal travel distances associated with high productivity stockpile load-out and batch plant applications.
- High Loading shot rock (large loaders) from a face. Steady loading from very tight banks. Continuous work on rough or very soft surfaces with high rolling resistance. Load and carry in hard digging material with longer travel distances on poor surfaces with adverse grades. Handling high density materials with counterweighted machine.

**Small and Medium Wheel Loader and Integrated Toolcarrier**

**Load Factor Guide**

(average engine load factor based on application description for each range)

Fuel rates can vary for a specific load factor depending on model and application, therefore some overlap is shown in the load factor table.

- Low 15%-30%
- Medium 25%-35%
- High 30%-45%

**Large Wheel Loaders**

**Load Factor Guide**

(average engine load factor based on application description for each range)

- Low 35%-50%
- Medium 50%-65%
- High 65%-80%

9

**PLANNED MAINTENANCE (PM)  
LUBE OILS, FILTERS, GREASE, LABOR**

Planned Maintenance (PM) costs should be developed by the Cat dealer, with customer input for the specific application.

PM costs include the parts and labor at the intervals specified in the Operation and Maintenance Manuals provided for each machine. PM costs for each machine may vary slightly depending upon factors required or specified by the customer. See your local Cat dealer to develop the specific PM cost per hour estimate for your machine and application.

**10a TIRES**

(Line Item 10a)

Tire costs are an important part of the hourly cost of any wheel machine. Tire costs are also one of the most difficult to predict with many variables. The best estimate for tire costs are obtained when tire life estimates are based upon actual customer experience, and are used with prices the machine owner actually pays for the replacement tires.

For cases in which tire experience is not available, use the following tire life estimator curves.

**Tire Life Estimators**

- Curves do not allow for additional life from recapping. They assume new tires run to destruction, but this is not necessarily recommended.
- Based on standard machine tires. Optional tires will shift these curves either up or down.
- Sudden failure (blow out) due to exceeding Ton-MPH (tkm/h) limitations is not considered. Nor are premature failures due to puncture.
- Application Descriptions/Zones:

Low/Zone A: almost all tires actually wear through the tread from abrasion.

Medium/Zone B: tires wear out normally but others fail prematurely due to rock cuts, impacts and non-repairable punctures.

High/Zone C: few, if any, tires wear through the tread due to non-repairable damages, usually from rock cuts, impacts and continuous overloading.

**NOTE:** Tire life can often be increased by using extra tread and extra deep tread tires.

**NOTE:** Premature failure could occur at any time due to puncture.

**MOTOR GRADERS**

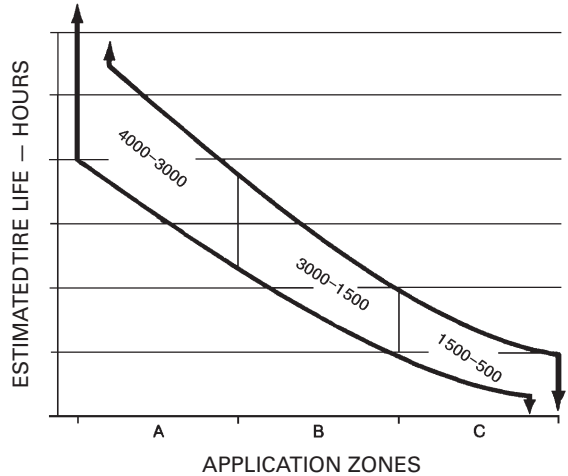

**SKIDDERS**

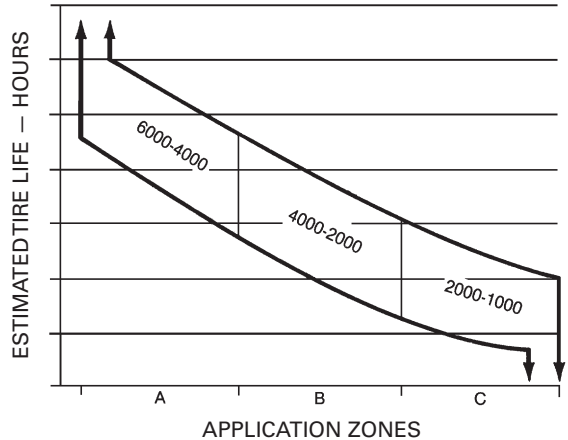

**SKID STEER LOADERS**

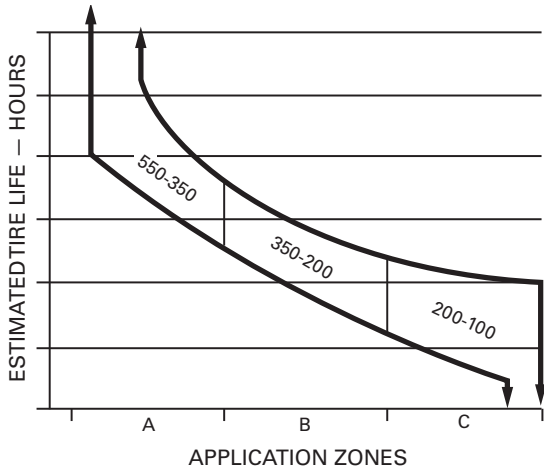

**LOAD HAUL DUMP UNITS**

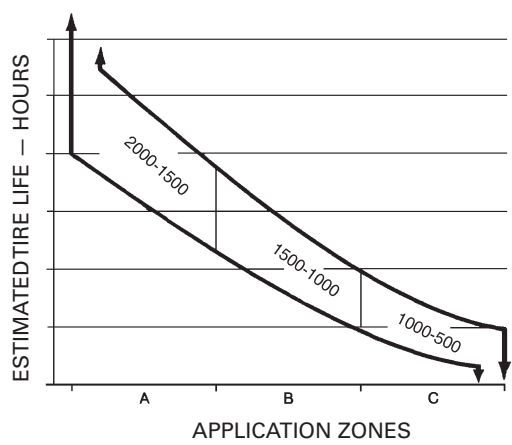

**WHEEL TRACTOR-SCRAPERS**

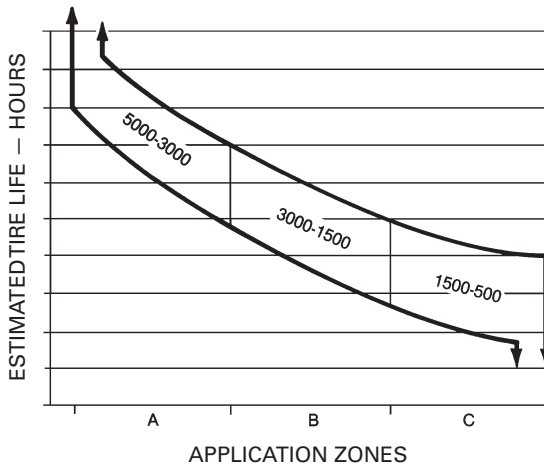

**MINING & OFF-HIGHWAY TRUCKS**

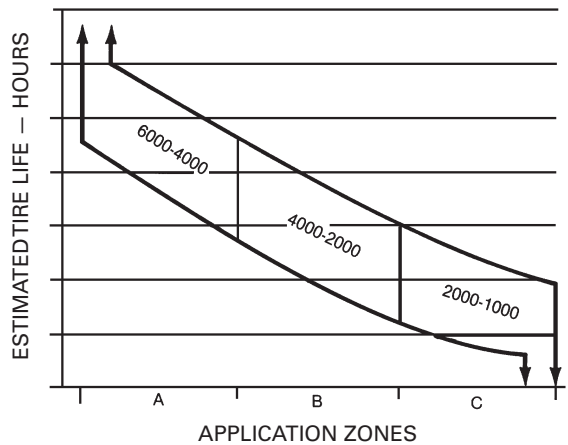

**Key:**

- Zone A – Almost all tires actually wear through the tread due to abrasion.
- Zone B – Some tires wear out normally while others fail prematurely due to rock cuts, impacts and non-repairable punctures.
- Zone C – Few, if any, tires wear through the tread because of non-repairable damages, usually from rock cuts, impacts or continuous overloading.

**UNDERGROUND TRUCKS**

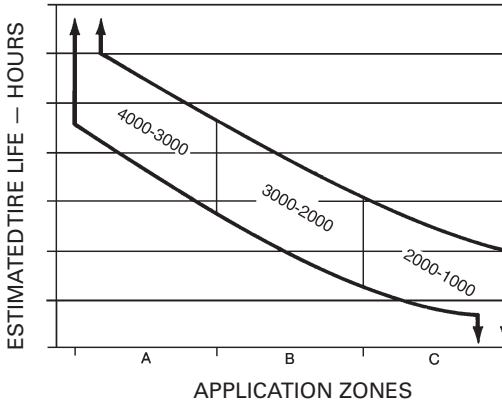

**TRACTORS/WAGONS**

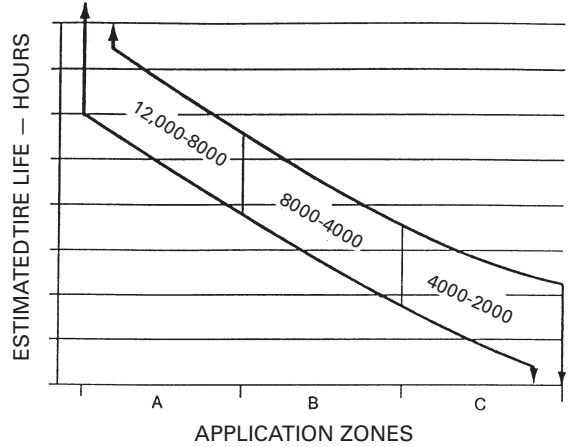

**ARTICULATED TRUCKS**

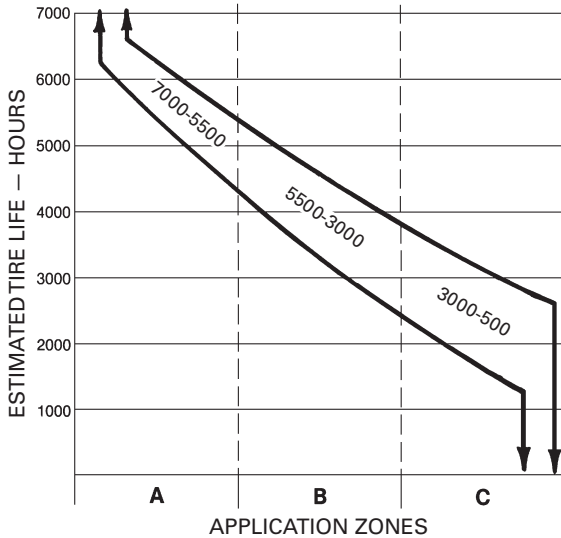

**WHEEL TRACTORS  
WHEEL LOADERS**

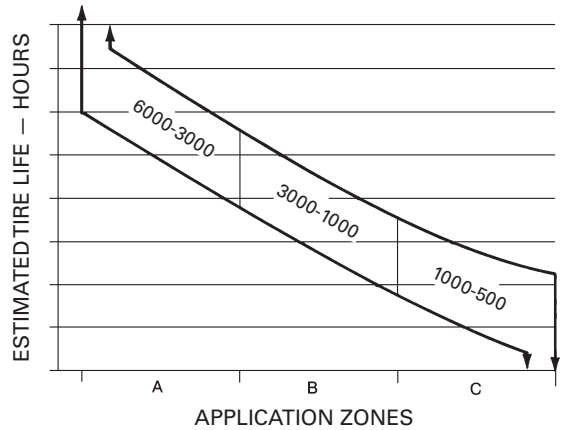

**Key:**

- Zone A – Almost all tires actually wear through the tread due to abrasion.
- Zone B – Some tires wear out normally, others fail prematurely due to rock cuts, impacts, and non-repairable punctures.
- Zone C – Few, if any, tires wear through the tread because of non-repairable damages, usually from rock cuts, impacts, or continuous overloading.

Application Tire Life	Tires Cost Per Hour – Basic Factors		
	Zone A 8000-5000	Zone B 5000-2500	Zone C 2500-500
Model 990 II 992G 994D	\$20-\$40	\$30-\$80	\$60-\$400

### GOODYEAR LIFE ESTIMATING SYSTEM

As an additional assist in estimating *hauling unit* tire life, Goodyear Tire and Rubber Co. has furnished the following information which is included here with their permission. READ THE PREAMBLE CAREFULLY.

“... at present, there is no completely accurate, fool-proof method of forecasting tire life. Tire engineers have many theoretical methods ... but these generally are so involved and time consuming that they are impractical for field use.

“However, the tire industry has made many surveys of tire performance and arrived at a system which can give rough *estimates* of tire life. Studies done by the major tire companies and by at least two major equipment manufacturers are in close agreement.

“The table [which follows] shows how to apply this system ...”

#### ESTIMATED TIRE SERVICE LIFE OF HAULING UNITS (Trucks and Scrapers)

No.	Condition	Factor
I	<b>Maintenance</b>	
	Excellent	1.090
	Average	0.981
	Poor	0.763
II	<b>Speeds (Maximum)</b>	
	16 km/h ~ 10 mph	1.090
	32 km/h ~ 20 mph	0.872
	48 km/h ~ 30 mph	0.763
III	<b>Surface Conditions</b>	
	Soft Earth — No Rock	1.090
	Soft Earth — Some Rock	0.981
	Well Maintained — Gravel Road	0.981
	Poorly Maintained — Gravel Road	0.763
	Blasted — Sharp Rock	0.654
IV	<b>Wheel Positions</b>	
	Trailing	1.090
	Front	0.981
	Driver (Rear Dump)	0.872
	(Bottom Dump)	0.763
	(Self Propelled Scraper)	0.654

No.	Condition	Factor
V	<b>Loads</b> (See No. VIII note)	
	T&RA/ETRTO* Recommended Loading	1.090
	20% Overload	0.872
	40% Overload	0.545
VI	<b>Curves</b>	
	None	1.090
	Medium	0.981
	Severe	0.872
VII	<b>Grades</b> (Drive Tires Only)	
	Level	1.090
	5% Max.	0.981
	15% Max.	0.763
VIII	<b>Other Miscellaneous Combinations</b> (See note below)	
	None	1.090
	Medium	0.981
	Severe	0.872
	<b>Condition VIII is to be used when overloading is present in combination with one or more of the primary conditions of maintenance, speeds, surface conditions and curves. The combination of severe levels in these conditions, together with an overload, will create a new and more serious condition which will contribute to early tire failure to a larger extent than will the individual factors of each condition.</b>	

\*Tire and Rim Association/European Tire and Rim Technical Organization.

#### Base Average Life

Type of Tire	Hours	km	Miles
E-3 Std. Bias Tread	2510	40 400	<b>25,100</b>
E-4 Bias Xtra Tread	3510	56 500	<b>35,100</b>
E-4 Radial Xtra Tread	4200	67 600	<b>42,000</b>

Using Base Hours (or Miles), multiply by the appropriate factor for *each* condition to obtain approximate estimated hours (or miles) as the final product.

*Example:* An off-highway truck equipped with E-4 drive tires running on a well maintained haul road having easy curves and minimum grades and receiving “average” tire maintenance attention but being 20% overloaded:

Condition: I II III IV V VI VII VIII  
 Factor: 0.981 × 0.872 × 0.981 × 0.872 × 0.872 × 0.981 × 0.981 × 0.981  
 × 3510 base hours = 2114 hours (say 2100 hours)

As can be seen, this system requires the careful application of strictly subjective judgments, and can be expected to result in conservative estimates. Keep in mind, however, **that the system is offered only as an aid in estimating and not as a rigid set of rules.**

On the other hand, if tire life on a given job is considered less than satisfactory, an analysis of these factors may point to conditions which can be improved to the betterment of tire life.

Replacement tire prices should always be obtained from local tire company sources.

Since tires are considered a wear item in this method of estimating owning and operating costs, total tire replacement cost is deducted from machine delivered price to arrive at a net figure for depreciation purposes. Outlay for tires is then included as an item in operating costs:

$$\text{Hourly Tire Cost} = \frac{\text{Replacement Cost of Tires}}{\text{Estimating Tire Life in Hours}}$$

Recapping can sometimes lower hourly tire cost. Considerations are availability of molds, local recapping costs, and experience with recap life.

10b

**UNDERCARRIAGE**

(Line Item 10b)

Undercarriage expense can be a major portion of the operating costs for track-type machines, and these costs can vary *independently* of basic machine costs. That is, the undercarriage can be employed in an extremely abrasive, high-wear environment while the basic machine may be in an essentially easy application, and vice-versa. For that reason, it is recommended that the hourly cost of undercarriage be calculated separately as a wear item rather than being included in the repair costs for the basic machine.

Three primary conditions affect probable life-expectancy of track-type undercarriage:

1. **Impact.** The most measurable effect of impact is structural – that is bending, chipping, cracking, spalling, roll-over, etc., and problems with hardware and pin and bushing retention.

*Impact ratings:*

*High* – Non-penetrable hard surfaces with 150 mm (6") or higher bumps.

*Moderate* – Partially penetrable surfaces and bumps of 75-150 mm (3-6") height.

*Low* – Completely penetrable surfaces (which provide full shoe plate support) with few bumps.

2. **Abrasiveness.** The tendency of the underfoot materials to grind away the wear surfaces of track components.

*Abrasiveness ratings:*

*High* – Saturated wet soils containing a high proportion of hard, angular or sharp sand or rock particles.

*Moderate* – Slightly or intermittently damp soils containing a low proportion of hard, angular or sharp particles.

*Low* – Dry soils or rock containing a low proportion of hard, angular or sharp sand or rock chip particles.

Impact and abrasiveness in combination can accelerate wear rates beyond their individual effects when considered alone, thus further reducing component life. This should be taken into account in determining impact and abrasiveness ratings or, if preferred, the combination can be included in selecting the “Z” factor.

3. **“Z” factor.** Represents the combined effect on component life of the many intangible environmental, operational and maintenance considerations on a given job.

*Environment and Terrain.* Earth which may not be abrasive itself can pack in sprocket teeth, causing mis-match and high stress as the teeth engage the bushings. Corrosive chemicals in the materials being moved or in the natural soil can affect wear rates, while moisture and temperature can exaggerate the effect. Temperature alone can play its own role – hot slag and hard-frozen soils being but the extremes. Constant sidehill work can increase wear on the sides of components.

*Operation.* Some operator practices tend to increase track wear and cost if not controlled on the job. Such practices include high-speed operation, particularly in reverse; tight turns or constant corrections in direction; and stalling the tractor under load forcing the tracks to slip.

*Maintenance.* Good maintenance – proper track tension, daily cleaning when working in sticky materials, etc. – combined with periodic wear measurement and timely attention to recommended services (CTS) can extend component life and lower costs by minimizing the effects of these and other adverse conditions.

While impact and abrasion should not be too difficult to judge, selection of the proper “Z” factor will require careful analysis of job conditions such as weather, tendency for soil packing, side-hill loading, corrosive environment, etc.; operational factors such as high-speed reverse, amount of travel, tight turns, track slippage under overload, etc.; and maintenance considerations such as proper tensioning, use of Custom Track Service, etc.

Selection of the “Z” multiplier is strictly a matter of judgement and common sense, but its effect on cost can be the difference between profit on a controlled job and heavy loss where control is allowed to slip. To assist in arriving at an appropriate value for the “Z” factor, consider that proper maintenance – or the lack thereof – will represent about 50% of its effect, environment and terrain 30%, and operator practices 20%. For large excavators the amount of travel is the critical part of the “Z” factor. A good operator working under good field conditions can be counterbalanced by poor maintenance practices to yield a fairly high “Z” factor. On the other hand, close attention to maintenance, tension and alignment can more than offset a bad underfoot condition resulting in severe sprocket packing, and lead to selection of a moderate to low “Z” factor. Obviously, flexibility in selection of a “Z” factor has been built into the system, and use of this flexibility is encouraged. Further, a considerable measure of control can be maintained over the “Z” factor, and any reduction of its effects is money in the bank. Your Cat dealer CTS man can be invaluable in this endeavor as well as helping you establish a comprehensive undercarriage cost control program.

**Estimating Undercarriage Cost**

The guide below gives a basic factor for the various track-type machines and a series of conditions multipliers to modify the basic cost according to the anticipated impact, abrasive and miscellaneous (“Z”) conditions under which the unit will be operating.

Step 1. Select machine and its corresponding basic factor.  
 Step 2. Determine range for impact, abrasiveness and “Z” conditions.

Step 3. Add selected conditions multipliers and apply sum to basic factor.

The result will be the estimated hourly cost for undercarriage in that application.

Undercarriage Basic Factors			
Model	Basic Factor		
5230B	28.2		
D11T	26.1		
5130B	20.4		
D10T2	16.2		
5110B	13.6		
D9T	10.9		
D8T	9.6		
973D, 587T, 589, D7R LGP, D7E LGP	11.2		
D7R, 963D, 583T, D6T LGP, D7R XR, D7E	9.1		
385C, 5090B	7.2		
D6T, 953D, 572R, 527	7.0		
365C	6.8		
345D	5.9		
D6N XL, 517	5.6		
336D	5.0		
D3K (All), D4K (All), D5K (All), 939C, PL61	4.1		
329D	3.9		
314D, 315D, 319D, 323D	3.4		
320D	2.9		
307D, 308D, 311D, 312D	2.4		
Conditions Multipliers			
	Impact	Abrasiveness	“Z”
High	0.3	1.0	1.0
Moderate	0.2	0.5	0.5
Low	0.1	0.1	0.2

*Example:* D10T2 in high impact, non-abrasive material with a moderate “Z” factor.

$$\begin{aligned}
 \text{D10T2 Basic Factor} &= 16.2 \\
 \text{Multipliers:} & \quad I = 0.3 \\
 & \quad A = 0.1 \\
 & \quad Z = 0.5
 \end{aligned}$$

$$\text{U.C. cost} = 16.2 (0.3 + 0.1 + 0.5) = \mathbf{\$14.58/hour}$$



- NOTE:** 1. Conditions Multipliers may be selected in any combination. Thus, a multiplier of 0.4 (all low-range multipliers) represents the best of the best, while 1.7 (all high range multipliers) would be the worst of the worst conditions.
2. The hourly undercarriage cost estimate resulting from this method will be made up of *approximately* 70% parts cost and 30% labor charges. The cost of undercarriage components is based on published U.S. Consumers List Prices and may be adjusted as needed for import duties, exchange rates, etc. outside the United States. Labor has been figured at \$60.00 (U.S.) per shop hour.
3. For further information and guidance, refer to the current issue of the Caterpillar Custom Track Service Handbook.
4. This formula for estimating undercarriage cost should not be used for tractors working in stockpile coal handling applications. Undercarriage costs are nominal in stockpile coal handling, and using this formula will result in estimating cost substantially above actual costs.

Machine applications, operating conditions, ownership periods, component life, and maintenance attention determine repair costs. In any specific application, actual cost experience on similar machines and applications provides the best basis for establishing the hourly repair cost.

Repairs and component lives are normally the largest single item in operating costs and include all parts and direct labor (except operator's wages) chargeable to the machine. Shop overhead can be absorbed in general overhead or charged to machines as a percent of direct labor cost, whichever is the owner's normal practice.

Hourly repair costs for a single machine normally follow an upward stairstep pattern since major outlays for repairs usually come in spurts. However, when broad averages are considered, the stairstep becomes a smooth, upward curve. Since this hourly repair cost curve starts low and gradually rises over time, hourly operating costs must be adjusted upward as the unit ages. Alternatively an average repair cost can be used which provides a straight line graph. Most owners prefer the average method, and it is the one suggested here.

Since repair costs are low initially and rise gradually, averaging them produces extra funds at first which are reserved to cover future higher costs.

**Your Cat dealer has the ability to make more accurate repair cost estimates and we suggest you use their experience and expertise if you need help in estimating operating costs.**

11

## REPAIR COSTS

*(Line Item 11)*

Repair cost per hour should be developed by the Cat dealer, with customer input for the specific machine application and requirements.

As with PM cost per hour, repair costs are significantly affected by the specific application and situation. Several important variables must be provided by the customer and the local Cat dealer. This will enable a calculated cost per hour that is specific to the machine conditions and customer needs.

As stated, repair costs are affected by application, operating conditions, ownership period, maintenance, and age of the equipment. The most significant effects on cost will be those factors affecting major component life. A second significant factor is whether the repair is performed before or after catastrophic failure. Repair before a major component fails can be one-third of an after failure repair with only a moderate sacrifice in life (see graphs). Oil analysis and other diagnostic tools, maintenance inspections and indicators, and operator notes are vital to determine the optimum repair point and thereby achieving lower hourly repair costs. Maintenance practices are significant because they affect component longevity and the percentage of scheduled, before failure repairs.

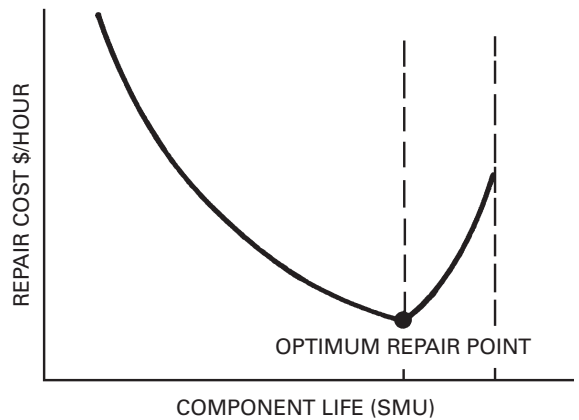
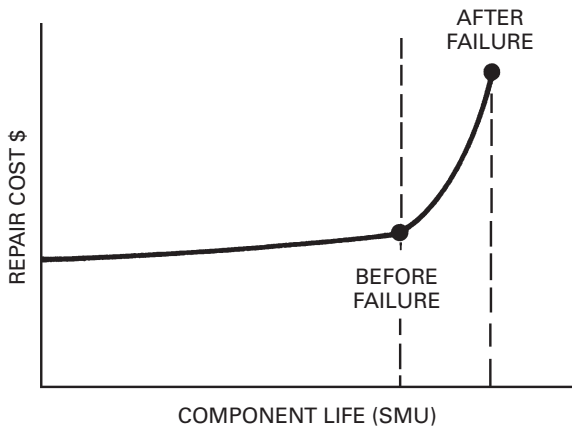

## Owning & Operating Costs

- ⑫ Special Wear Items
  - ⑮ Operator's Hourly Wage
- ### Owning & Operating Examples
- Track-Type Tractor

12

### SPECIAL WEAR ITEMS

(Line Item 12 and Subsection 12A)

All costs for high-wear items such as cutting edges, ripper tips, bucket teeth, body liners, router bits, etc., and welding costs on booms and sticks should be included here. These costs will vary widely depending on applications, materials and operating techniques. Consult your Cat dealer Parts Department for estimated life under your job conditions.

15

### OPERATOR'S HOURLY WAGE

(Line Item 15)

This item should be based on local wage scales and should include the hourly cost of fringe benefits.

## EXAMPLES OF FIGURING OWNING AND OPERATING COSTS

(The following two examples are for illustrative purposes only. The intent is to show how the worksheets could be filled out. The PM and Repair costs should be developed by your local Cat dealer.)

### Example I: ESTIMATING HOURLY OWNING AND OPERATING COSTS OF A TRACK-TYPE TRACTOR

Assume a power shift track-type tractor with straight bulldozer, hydraulic control, tilt cylinder and three-shank ripper, is purchased by a contractor for \$135,000, delivered price at job site.

Application will be production dozing of bank gravel. Minimal ripping will be required to loosen material.

In the following calculations, refer as necessary to the source material already reviewed.

#### OWNING COSTS —

##### To Determine Residual Value at Replacement

Enter delivered price, \$135,000, in space (A). (See example form at end of this discussion.) Since the machine being considered is a track-type tractor, no tires are involved. This particular owner's experience is that at trade-in time, the tractor will be worth approximately 35% of its original value. This \$47,250 trade-in value is entered in space (B) leaving a net of \$87,750 to be recovered through work.

Enter the net value to be recovered through work in space (C).

Indicated ownership period is 7 years with annual usage of 1200 hours per year or 8400 hours of total ownership usage.

Divide the Net Value from space (C), \$87,750, by Ownership Usage, 8400 hours, and enter result \$10.45 in space (D).

#### Interest, Insurance, Taxes

In this example, local rates are assumed as follows:

Interest	16%
Insurance	1%
Taxes	1%
	18%

Using the following formula:

$N = 7:$

$$\left[ \frac{135,000(7+1) + 47,250(7-1)}{2 \times 7} \right] \times 0.18 = 12.99$$

Enter \$12.99 in space (E).

Insurance and property taxes can also be calculated using the same formula as shown for the interest cost, and entering them on lines 5 and 6.

Items 3b, 4, 5 and 6 can now be added and the result, \$25.06 entered in space (H) Total Hourly Owning Costs.

#### OPERATING COSTS —

##### Fuel

See fuel consumption tables. The intended application, production dozing, indicates a medium load factor. Assume that the estimated fuel consumption from the table is 17 liter/hr (4.5 U.S. gal/hr.). Cost of fuel in this locality is \$0.34/liter (\$1.25/U.S. gal.).

Consumption	Unit Cost	Total
17 liter/hr	× \$0.34 liter	= \$5.78
4.5 gal/hr	× \$1.25 gal.	= \$5.63

Enter this figure in space (I).

**Planned Maintenance (PM) Cost per Hour**

Use PM cost per hour estimate developed by your local Cat dealer. (For this example assume cost per hour is \$2.30) Enter this figure in space (J) on line 9.

**Tires**

Since this example considers a track-type tractor, space (K) is left blank.

**Undercarriage**

Our estimating reference gives an undercarriage cost Basic Factor of 6.6 for this tractor. It is anticipated that with some ripping on the job, impact loading of track components will be medium, indicating an “I” multiplier of 0.2. The gravel-sand mix in the bank, being dry, should be only moderately abrasive for an “A” multiplier of 0.2. In analyzing the miscellaneous conditions: there is enough clay in the bank to produce some packing of the sprockets; the operator is careful, but is forced into some tight turns because of space limitations; there is good drainage in the pit; track tension is checked weekly; and all track-type equipment on the job is enrolled in the Custom Track Service program. Accordingly, the “Z” multiplier is judged to be somewhat greater than low level — 0.3 in this case.

It should be noted that in applying particularly the “Z” factor, rather wide flexibility is provided and was used in the above example. Such flexibility is intended and its use encouraged.

Then:

$$\text{Cost per hour} = \text{Basic Factor} \times (\text{I} + \text{A} + \text{Z})$$

$$\text{Basic Factor} = 6.6$$

$$\text{Conditions Multipliers: I} = 0.2$$

$$\text{A} = 0.2$$

$$\text{Z} = 0.3$$

$$\text{Cost per hour } 6.6 (0.2 + 0.2 + 0.3) = \$4.62 \text{ which is entered in space (L).}$$

**Repair Cost per Hour**

Use the Repair cost per hour estimate developed by your local Cat dealer. (For this example assume cost per hour is \$6.12) Enter this figure in space (M) on line 11.

**Special Items**

Assuming the tractor is equipped with a three-shank ripper and an “S” dozer, allowance must be made for ripper tips, shank protectors, and dozer cutting edges.

Assume your knowledge of the operation indicates the ripper will be used only about 20% of total tractor operating time. Estimated tip life while in use is 30 hours. Therefore, tips will be replaced:

$$\frac{30 \text{ Hours}}{0.20} = \text{each 150 hours of tractor operation}$$

Shank protector life is estimated at three times tip life or 450 hours of tractor operation.

Cutting edge life is estimated to be 500 hours.

Using local prices for these items, hourly costs are estimated as follows:

$$\text{Tips: } \frac{3 @ \$35.00 \text{ ea.}}{150 \text{ hr.}} = \$0.70 \text{ per hour}$$

$$\text{Shank Protectors: } \frac{3 @ \$55.00 \text{ ea.}}{450 \text{ hr.}} = \$0.37 \text{ per hour}$$

$$\text{Cutting Edges: } \frac{\$125 \text{ per set}}{500 \text{ hr.}} = \$0.25 \text{ per hour}$$

The total of these, \$1.32; is entered in space (N).

Items 8, 9, 10b, 11 and 12 can now be added and the result, \$19.99, is entered in space (O), Total Hourly Operating Costs.

**Operator’s Hourly Wage**

Assume this is \$25.00 including fringe benefits. This figure is entered in space (P).

Total Owning Costs, Total Operating Costs and Operator’s Hourly Wage are now added together and the result, \$67.01, is entered in space (Q). The itemized estimate of Hourly Owning and Operating Costs is now complete.

**Example II: ESTIMATING HOURLY OWNING AND OPERATING COSTS OF A WHEELED VEHICLE**

With only a few simple changes, owning and operating costs for a wheeled vehicle are calculated using the same format as that used for the Track-Type Tractor. Only the differences will be explained as we look at example calculations for a wheel loader.

**OWNING COSTS —****To Determine Residual Value at Replacement**

Enter delivered price in space (A). The cost of tires is deducted since they will be treated as a wear item. For purposes of illustration, the Wheel Loader is estimated to have a potential 48% trade-in value (B) at the end of the 5 year/7500 hour ownership usage, leaving a net value to be recovered through work of \$34,320 (C).

**Interest, Insurance, Taxes**

Refer to the formulas using the same rates as before and 1500 operating hours per year. The result \$4.22 is applied to the interest cost (E).

Insurance and property taxes can also be calculated using the same formula as shown for the interest cost.

The sum of lines 3b, 4, 5 and 6 gives the total hourly owning cost, line 7.

**OPERATING COSTS —****Fuel**

See the fuel consumption tables and apply the actual cost of purchasing fuel in the project area (I).

**Planned Maintenance (PM) Cost per Hour**

Use PM cost per hour estimate developed by your local Cat dealer. (For this example assume cost per hour is \$2.10.) Enter this figure in space (J) on line 9.

**Tires**

Use the tire replacement cost and the best estimate of tire life based on experience and anticipated job conditions.

**Repair Cost per Hour**

Use the Repair cost per hour estimate developed by your local Cat dealer. (For this example assume cost per hour is \$3.39.) Enter this figure in space (M) on line 11.

**Special Items**

Ground engaging tools, welding, etc. are covered here. Use current costs for cutting edges and similar items. Use your best estimate of the hours of life which can be expected from them based on previous experience in like materials. Enter the total on line 12.

The total of lines 8 through 13 represents hourly operating costs.

**Operator's Hourly Wage**

To give a true picture of operator cost, include fringe benefits as well as direct hourly wages (line 15).

**TOTAL O&O**

The total of lines 7, 13 and 15 is the total hourly owning and operating cost of the machine. Keep in mind that this is an estimate and can change radically from project to project. For the greatest accuracy, the hourly cost reflected in actual on-the-job cost records should be used.

**HOURLY OWNING AND OPERATING COST ESTIMATE**

DATE \_\_\_\_\_

	Estimate #1	Estimate #2
A—Machine Designation . . . . .	Track-type Tractor	Wheel Loader
B—Estimated Ownership Period (Years) . . . . .	7	5
C—Estimated Usage (Hours/Year) . . . . .	1200	1500
D—Ownership Usage (Total Hours)(B × C). . . . .	8400	7500

**OWNING COSTS**

1. a. Delivered Price (P), to the Customer (including attachments) . .	(1) 135,000 (A)	(2) 70,000
b. Less Tire Replacement Cost if desired . . . . .	N/A	4000
c. Delivered Price Less Tires. . . . .	135,000	66,000
2. Less Residual Value at Replacement (S) . . . . . (35%)	47,250 (B)	(48%) 31,680
(See subsection 2A on back)		
3. a. Net Value to be recovered through work . . . . .	87,750 (C)	34,320
(line 1c less line 2)		
b. Cost Per Hour:		
Net Value (1) 87,750 (2) 34,320 . . . . .	10.45 (D)	4.58
Total Hours 8400 7500		
4. Interest Costs $\frac{P(N + 1) + S(N - 1)}{2N} \times \text{Simple Int. \% Rate}$		
N = No. Yrs. Hours/Year =		
(1) $\frac{[135,000(7 + 1)] + [47,250(7 - 1)]}{2 \times 7} \times 0.16$	(2) $\frac{[66,000(5 + 1)] + [31,680(5 - 1)]}{2 \times 5} \times 0.16$	
1200 Hours/Yr. =	1500 Hours/Yr. =	12.99 (E) 5.58
5. Insurance $\frac{P(N + 1) + S(N - 1)}{2N} \times \text{Insurance \% Rate}$		
N = No. Yrs. Hours/Year =		
(1) $\frac{[135,000(7 + 1)] + [47,250(7 - 1)]}{2 \times 7} \times 0.01$	(2) $\frac{[66,000(5 + 1)] + [31,680(5 - 1)]}{2 \times 5} \times 0.01$	
1200 Hours/Yr. =	1500 Hours/Yr. =	0.81 (F) 0.35

(Optional method when Insurance cost per year is known)

Ins. \$ \_\_\_\_\_ PerYr. ÷ \_\_\_\_\_ Hours/Yr. =

*Estimating form continues next page*

	Estimate #1	Estimate #2
6. Property Tax $\frac{P(N + 1) + S(N - 1)}{2N} \times \text{Tax Rate \%}$ N = No. Yrs. $\frac{\hspace{10em}}{\text{Hours/Year}} =$		
(1) $\frac{[135,000 (7 + 1)] + [47,250 (7 - 1)]}{2 \times 7} \times 0.01$ $\frac{\hspace{10em}}{1200 \text{ Hours/Yr.}} =$		
(2) $\frac{[66,000 (5 + 1)] + [31,680 (5 - 1)]}{2 \times 5} \times 0.01$ $\frac{\hspace{10em}}{1500 \text{ Hours/Yr.}} =$	<u>0.81 (G)</u>	<u>0.35</u>
(Optional method when Property Tax cost per year is known) Property Tax \$ _____ Per Yr. $\div$ _____ Hours/Yr. =		
7. TOTAL HOURLY OWNING COST (add lines 3b, 4, 5 and 6) .....	<u>25.06 (H)</u>	<u>10.86</u>
<b>OPERATING COSTS</b>		
8. Fuel: $\frac{\text{Unit Price} \times \text{Consumption}}{\hspace{10em}} =$		
(1) $\frac{1.25 \times 4.50}{\hspace{10em}} =$	<u>5.63 (I)</u>	<u>2.50</u>
(2) $\frac{1.25 \times 2}{\hspace{10em}} =$		
9. Planned Maintenance (PM)-Lube Oils, Filters, Grease, Labor: (contact your local Cat dealer) .....	<u>2.30 (J)</u>	<u>2.10</u>
10. a. Tires: Replacement Cost $\div$ Life in Hours $\frac{\text{Cost}}{\text{Life}}$ (1) $\frac{\text{N/A}}{\hspace{10em}}$ (2) $\frac{4000}{3500}$ .....	<u>(K)</u>	<u>1.14</u>
b. Undercarriage (Impact + Abrasiveness + Z Factor) $\times$ Basic Factor (1) $(\underline{0.2} + \underline{0.2} + \underline{0.3}) = \underline{0.7} \times \underline{6.6} =$ (2) $(\underline{\hspace{1em}} + \underline{\hspace{1em}} + \underline{\hspace{1em}}) = \underline{\hspace{1em}} \times \underline{\hspace{1em}} =$ <span style="margin-left: 10em;">(Total)      (Factor)</span>	<u>4.62 (L)</u>	
11. Repair Cost (Per Hour) (contact your local Cat dealer) .....	<u>6.12 (M)</u>	<u>3.39</u>
12. Special Wear Items: Cost $\div$ Life ..... (See subsection 12A on back)	<u>1.32 (N)</u>	<u>0.60</u>
13. TOTAL OPERATING COSTS (add lines 8, 9, 10a (or 10b), 11 and 12) .....	<u>19.99 (O)</u>	<u>9.73</u>
14. MACHINE OWNING PLUS OPERATING (add lines 7 and 13) .....	<u>45.05</u>	<u>20.59</u>
15. OPERATOR'S HOURLY WAGE (include fringes) .....	<u>25.00 (P)</u>	<u>25.00</u>
16. TOTAL OWNING AND OPERATING COST .....	<u><u>70.05(Q)</u></u>	<u><u>45.59</u></u>

**SUBSECTION 2A: Residual Value at Replacement**

Gross Selling Price	(est. #1) (___%)	_____	(est. #2) (___%)	_____
Less: a. Commission		_____		_____
b. Make-ready costs		_____		_____
c. Inflation during ownership period*		_____		_____
Net Residual Value		<u>47,250</u>	( <u>35</u> %)	<u>31,680</u> ( <u>48</u> %) of original delivered price
(Enter on line 2)				

\*When used equipment auction prices are used to estimate residual value, the effect of inflation during the ownership period should be removed to show in constant value what part of the asset must be recovered through work.

**SUBSECTION 12A: Special Items  
 (cutting edges, ground engaging tools, bucket teeth, etc.)**

(1)	Cost	Life	Cost/Hour	(2)
1.	<u>105</u>	÷ <u>150</u>	= <u>0.70</u>	1. <u>120</u> ÷ <u>200</u> = <u>0.60</u>
2.	<u>165</u>	÷ <u>450</u>	= <u>0.37</u>	2. _____ ÷ _____ = _____
3.	<u>125</u>	÷ <u>500</u>	= <u>0.25</u>	3. _____ ÷ _____ = _____
4.	_____	÷ _____	= _____	4. _____ ÷ _____ = _____
5.	_____	÷ _____	= _____	5. _____ ÷ _____ = _____
6.	_____	÷ _____	= _____	6. _____ ÷ _____ = _____
	Total	(1)	<u>1.32</u>	(2) <u>0.60</u>

(Enter total on line 12)





# FORMER MODELS



## TRACK-TYPE TRACTORS

Model	Product Ident. No. Prefix	Years Built	Horse-power FW/ Drawbar	Approx. Machine Weight kg (lb)	Gauge m (ft) and Width m (ft)	Length m (ft) and Height m (ft)	Transmission	Rated Drawbar Pull — kg (lb) and Forward Speed — km/h (mph)					
								1st	2nd	3rd	4th	5th	6th
D2	4U	47-58	43/38	3258 (7175)	1.02 (3'4") 1.42 (4'8")	2.74 (9'0") 1.57 (5'2")	DD	3609 (7950)	2588 (5700)	2061 (4540)	1634 (3600)	1067 (2350)	
D2	4U	47-58	42/35	3258 (7175)	1.02 (3'4") 1.57 (5'2")	2.74 (9'0") 1.57 (5'2")	DD	3609 (7950)	2588 (5700)	2061 (4540)	1634 (3600)	1067 (2350)	
D2	5U	57-58	38/32	3119 (5870)	1.27 (4'2") 1.42 (4'8")	2.74 (9'0") 1.57 (5'2")	DD	3033 (6680)	2483 (5420)	2007 (4420)	1703 (3570)	1035 (2280)	
D2	5U	57-58	43/38	3373 (7430)	1.27 (4'2") 1.67 (5'6")	2.74 (9'0") 1.57 (5'2")	DD	3609 (7950)	2588 (5700)	2061 (4540)	1634 (3600)	1067 (2250)	
D3	79U	72-79	62/—	4812 (10,610)	1.42 (4'8") 1.78 (5'10")	2.77 (9'1") 1.70 (5'7")	PS						
D3 LGP	6N	72-79	62/—	5410 (11,925)	1.65 (5'5") 2.29 (7'6")	2.97 (9'10") 1.70 (5'7")	PS						
D3B	23Y	79-87	65	6719 (14,812)	1.42 (4'8") 1.78 (5'10")	2.77 (9'1") 2.67 (8'9")	PS						
D3B	27Y	79-87	65	6877 (15,160)	1.42 (4'8") 1.78 (5'10")	2.77 (9'1") 2.67 (8'9")	PS						
D3B LGP	24Y	79-87	65	7479 (16,488)	1.65 (5'5") 2.29 (7'6")	2.99 (9'10") 2.67 (8'9")	PS						
D3B LGP	28Y	79-87	65	7637 (16,836)	1.65 (5'5") 2.29 (7'6")	2.99 (9'10") 2.67 (8'9")	PS						
D3B	3YC	85-87	65	6719 (14,812)	1.42 (4'8") 1.78 (5'10")	2.77 (9'1") 2.67 (8'9")	DD	5593 (12,330)	3993 (8802)	2694 (5940)	1830 (4034)	1326 (2925)	
D3B LGP	5MC	85-87	65	7479 (16,488)	1.65 (5'5") 2.29 (7'6")	2.99 (9'10") 2.67 (8'9")	DD	5595 (12,330)	3993 (8802)	2694 (5940)	1830 (4034)	1326 (2925)	

NOTE: Power Shift models show speeds only, not drawbar pull.  
NOTE: Track-Type Tractor weights do not include blades until 1967.

Track-Type Tractors (cont'd)

Model	Product Ident. No. Prefix	Years Built	Horse-power FW/ Drawbar	Approx. Machine Weight kg (lb)	Gauge m (ft) and Width m (ft)	Length m (ft) and Height m (ft)	Transmission	Rated Drawbar Pull — kg (lb) and Forward Speed — km/h (mph)						
								1st	2nd	3rd	4th	5th	6th	
D3C	5KG	87-90	67	7084 (15,618)	1.42 (4'8") 1.79 (5'10.6")	2.8 (9'4") 2.66 (8'8.9")	PS							
D3C Series II		90-93	70	7001 (15,435)	1.42 (4'8") 1.79 (5'11")		PS	3.1 (1.9)	5.9 (3.7)	10.8 (6.7)				
D3C Series III		93-01	70	7110 (15,650)	1.45 (4'9") 1.85 (6'1")	3.98 (13'1") 2.73 (8'11")	HYS		0-9.0 (0-5.6)					
D3C XL Series II		91-93	70	7242 (15,965)	1.42 (4'8") 1.83 (6'0")		PS	3.1 (1.9)	5.9 (3.7)	10.8 (6.7)				
D3C XL Series III		93-01	70	7304 (16,100)	1.45 (4'9") 1.85 (6'1")	3.98 (13'1") 2.73 (8'11")	HYS		0-9.0 (0-5.6)					
D3G XL	CFC	01-03	70	7314 (16,125)	1.45 (4'9") 1.85 (6'1")	4.02 (13'2") 2.72 (8'11")	HYS		0-9.0 (0-5.6)					
D3G XL*	JMH	03-07	70	7345 (16,193)	1.45 (4'9") 1.85 (6'1")	4.02 (13'2") 2.72 (8'11")	HYS		0-9.0 (0-5.6)					
D3C LGP	1PJ	87-90	67	7788 (17,170)	1.65 (5'4") 2.29 (7'6")	3.0 (9'10.1") 2.66 (8'8.9")	PS	3.1 (1.9)	5.9 (3.7)	10.8 (6.7)				
D3C LGP Series II		90-93	70	7788 (17,170)	1.65 (5'5") 2.29 (7'6")		PS	3.1 (1.9)	5.9 (3.7)	10.8 (6.7)				
D3C LGP Series III		93-01	70	7710 (17,000)	1.68 (5'6") 2.31 (7'7")	3.95 (13'0") 2.73 (8'11")	HYS		0-9.0 (0-5.6)					
D3G LGP	CFF	01-03	70	7723 (17,026)	1.68 (5'6") 2.31 (7'7")	4.02 (13'2") 2.72 (8'11")	HYS		0-9.0 (0-5.6)					
D3G LGP*	BYR	03-07	70	7768 (17,126)	1.68 (5'6") 2.31 (7'7")	4.02 (13'2") 2.72 (8'11")	HYS		0-9.0 (0-5.6)					

\*Meets U.S. EPA Tier 2/EU Stage II/Japan 2001 (Tier 2) equivalent emission standards.

NOTE: Power Shift models show speeds only, not drawbar pull.

NOTE: Track-Type Tractor weights do not include blades until 1967.

Track-Type Tractors (cont'd)

Model	Product Ident. No. Prefix	Years Built	Horse-power FW/ Drawbar	Approx. Machine Weight kg (lb)	Gauge m (ft) and Width m (ft)	Length m (ft) and Height m (ft)	Transmission	Rated Drawbar Pull — kg (lb) and Forward Speed — km/h (mph)					
								1st	2nd	3rd	4th	5th	6th
								D4	6U	47-59	48/43	4629 <b>(10,195)</b>	1.12 <b>(3'8")</b> 1.58 <b>(5'2")</b>
D4	6U	47-59	60/48	4847 <b>(10,675)</b>	1.12 <b>(3'8")</b> 1.58 <b>(5'2")</b>	3.16 <b>(10'5")</b> 1.54 <b>(5'1")</b>	DD	4858 <b>(10,700)</b>	3496 <b>(7700)</b>	2724 <b>(6000)</b>	2093 <b>(4610)</b>	1326 <b>(2920)</b>	9.8 <b>(6.1)</b>
D4	6U	47-59	63/50	4844 <b>(10,675)</b>	1.12 <b>(3'8")</b> 1.58 <b>(5'2")</b>	3.18 <b>(10'5")</b> 1.76 <b>(5'10")</b>	DD	4858 <b>(10,700)</b>	3528 <b>(7770)</b>	2724 <b>(6000)</b>	2093 <b>(4610)</b>	1326 <b>(2920)</b>	9.8 <b>(6.1)</b>
D4	7U	47-59	63/50	5067 <b>(10,970)</b>	1.52 <b>(5'0")</b> 1.98 <b>(6'6")</b>	3.16 <b>(10'5")</b> 1.76 <b>(5'10")</b>	DD	4858 <b>(10,700)</b>	3528 <b>(7770)</b>	2724 <b>(6000)</b>	2093 <b>(4610)</b>	1326 <b>(2920)</b>	9.8 <b>(6.1)</b>
D4B	2XF	87	75	7450 <b>(16,420)</b>	1.42 <b>(4'8")</b> 1.78 <b>(5'10")</b>	2.78 <b>(9'1")</b> 2.67 <b>(8'9")</b>	PS						
D4B LGP	1SG	87	75	7800 <b>(17,200)</b>	1.65 <b>(5'5")</b> 2.29 <b>(7'6")</b>	2.99 <b>(9'10")</b> 2.67 <b>(8'9")</b>	PS						
D4C	39A	59-63	65/52	5064 <b>(11,155)</b>	1.12 <b>(3'8")</b> 1.58 <b>(5'2")</b>	3.05 <b>(10'1")</b> 1.76 <b>(5'10")</b>	DD	4858 <b>(10,700)</b>	3528 <b>(7770)</b>	2724 <b>(6000)</b>	2093 <b>(4610)</b>	1321 <b>(2910)</b>	9.8 <b>(6.1)</b>
D4C	40A	59-63	65/52	4881 <b>(10,750)</b>	1.52 <b>(5'0")</b> 1.98 <b>(6'6")</b>	3.05 <b>(10'1")</b> 1.76 <b>(5'10")</b>	DD	4858 <b>(10,700)</b>	3528 <b>(7770)</b>	2724 <b>(6000)</b>	2093 <b>(4610)</b>	1321 <b>(2910)</b>	9.8 <b>(6.1)</b>
D4C	1RJ	87-90	78	7581 <b>(16,714)</b>	1.42 <b>(4'7")</b> 1.83 <b>(6'0")</b>	3.00 <b>(9'10.1")</b> 2.66 <b>(8'8.9")</b>	PS						
D4C Series II		90-93	80	7557 <b>(16,660)</b>	1.42 <b>(4'8")</b> 1.83 <b>(6'5")</b>		PS						
D4C Series III		93-01	80	7330 <b>(16,150)</b>	1.50 <b>(4'11")</b> 1.91 <b>(6'3")</b>	3.99 <b>(13'1")</b> 2.73 <b>(8'11")</b>	HYS						
D4C XL Series III		93-01	80	7520 <b>(16,570)</b>	1.50 <b>(4'11")</b> 1.96 <b>(6'5")</b>	3.99 <b>(13'1")</b> 2.73 <b>(8'11")</b>	HYS						

NOTE: Power Shift models show speeds only, not drawbar pull.  
NOTE: Track-Type Tractor weights do not include blades until 1967.

Track-Type Tractors (cont'd)

Model	Product Ident. No. Prefix	Years Built	Horse-power FW/ Drawbar	Approx. Machine Weight kg (lb)	Gauge m (ft) and Width m (ft)	Length m (ft) and Height m (ft)	Transmission	Rated Drawbar Pull — kg (lb) and Forward Speed — km/h (mph)						
								1st	2nd	3rd	4th	5th	6th	
D4C LGP	2CJ	87-90	78	7905 (17,427)	1.65 (5'4") 2.29 (7'6")	3.00 (9'10.1") 2.66 (8'8.9")	PS							
D4C LGP Series II		90-93	80	7905 (17,427)	1.65 (5'5") 2.29 (7'6")		PS	3.2 (2.0)	5.9 (3.7)	11.1 (6.9)				
D4C LGP Series III		93-01	80	7790 (17,160)	1.68 (5'6") 2.31 (7'6")	3.99 (13'1") 2.73 (8'11")	HYS		0-9.0 (0-5.6)					
D4D	78A	63-68	65/52	5900 (13,000)	1.52 (5'0") 1.98 (6'6")	3.35 (11'0") 2.41 (7'11")	DD	5300 (11,690)	3700 (8160)	2560 (5640)	1880 (4150)	1350 (2980)		
D4D	22C	67-68	65/—	5900 (13,100)	1.52 (5'0") 1.98 (6'6")	3.38 (11'1") 2.41 (7'11")	PS							
D4D	82J	63	—/65	7910 (17,440)	1.52 (5'0") 1.98 (6'6")	3.38 (11'1") 2.67 (8'9")	DD	6150 (13,550)	4150 (9140)	2820 (6210)	2030 (4480)	1420 (3120)		
D4D	83J	67-71	—/65	8270 (18,240)	1.52 (5'0") 1.98 (6'6")	3.38 (11'1") 2.67 (8'9")	PS							
D4D	83J	72-77	—/75	5900 (13,100)	1.52 (5'0") 1.98 (6'6")	3.38 (11'1") 2.67 (8'9")	DD	6150 (13,550)	4150 (9140)	2820 (6210)	2030 (4480)	1420 (3120)		
D4E	27X	77-84	80/—	9013 (19,820)	1.52 (5'0") 2.44 (8'0")	3.86 (12'8") 2.72 (8'11")	DD	6495 (14,320)	4425 (9756)	3018 (6654)	2172 (4788)	1509 (3327)		
D4E	28X	77-84	80/—	9090 (20,040)	1.52 (5'0") 2.44 (8'0")	3.86 (12'8") 2.72 (8'11")	PS							
D4G XL	CFN	01-03	80	7761 (17,110)	1.50 (4'11") 1.96 (6'5")	4.04 (13'3") 2.72 (8'11")	HYS							
D4G XL*	HYD	03-07	80	7800 (17,196)	1.50 (4'11") 1.96 (6'5")	4.04 (13'3") 2.72 (8'11")	HYS							

\*Meets Tier 2/Stage II/Japan 2001 (Tier 2) equivalent emission standards.

NOTE: Power Shift models show speeds only, not drawbar pull.

NOTE: Track-Type Tractor weights do not include blades until 1967.

## Track-Type Tractors (cont'd)

Model	Product Ident. No. Prefix	Years Built	Horsepower FW/ Drawbar	Approx. Machine Weight (kg (lb))	Gauge m (ft) and Width m (ft)	Length m (ft) and Height m (ft)	Transmission	Rated Drawbar Pull — kg (lb) and Forward Speed — km/h (mph)							
								1st	2nd	3rd	4th	5th	6th		
D4G LGP	FDC	01-03	80	8109 (17,877)	1.68 (5'6")	4.04 (13'3")	HYS								
D4G LGP**	TLX	03-07	80	8143 (17,952)	2.31 (7'7")	2.72 (8'11")	HYS	0-9.0 (0-5.6)							
D4H (JPN)	8PB*	85-89	90/—	9975 (21,991)	1.67 (5'6")	3.422 (11'3")	PS								
D4H (JPN)	2AC*	85-89	90/—	10 111 (22,291)	2.13 (7'0")	2.933 (9'8")	DD	3.5 (2.2)	6.2 (3.9)	10.2 (6.3)					
D4H (JPN)	8PB*	89-90	95/—	10 105 (22,277)	1.67 (5'6")	3.422 (11'3")	PS	7618 (16,798)	5843 (12,884)	4333 (9554)	3207 (7071)	2335 (5149)	1640 (3617)		
D4H (JPN)	8PB	91-96	95/—	11 019 (24,242)	1.67 (5'6")	3.44 (11'3")	PS	2.5 (1.6)	3.2 (2.0)	4.3 (2.6)	5.5 (3.4)	7.2 (4.4)	9.5 (5.9)		
D4H (JPN)	2AC*	89-90	95/—	10 231 (22,555)	2.13 (7'0")	2.933 (9'8")	DD	3.5 (2.2)	6.2 (3.9)	10.2 (6.3)					
D4H (JPN)	2AC	91-96	95/—	11 019 (24,242)	1.67 (5'6")	3.44 (11'3")	DD	7454 (16,434)	5715 (12,599)	4235 (9336)	3132 (6904)	2277 (5020)	1597 (3520)		
D4H LGP (JPN)	9DB*	85-89	90/—	11 245 (24,790)	2.00 (6'7")	3.693 (10'4")	PS	2.5 (1.6)	3.2 (2.0)	4.3 (2.6)	5.5 (3.4)	7.2 (4.4)	9.5 (5.9)		
D4H LGP (JPN)	3AC*	85-89	90/—	11 381 (25,090)	2.76 (9'1")	2.986 (9'10")	DD	3.5 (2.2)	6.2 (3.9)	10.2 (6.3)					
D4H LGP (JPN)	9DB*	89-90	95/—	11 350 (25,022)	2.00 (6'7")	3.693 (10'4")	PS	7618 (16,798)	5843 (12,884)	4333 (9554)	3207 (7071)	2335 (5149)	1640 (3617)		
D4H LGP (JPN)	9DB	91-96	105/—	12 440 (27,368)	2.76 (9'1")	2.986 (9'10")	PS	2.5 (1.6)	3.2 (2.0)	4.3 (2.6)	5.5 (3.4)	7.2 (4.4)	9.5 (5.9)		
					2.00 (6'7")	3.718 (12'2")	PS	3.4 (2.1)	6.0 (3.7)	10.2 (6.4)					

\*D4H models prior to Series II. Product identification number prefix still in use for current product.

\*\*Meets Tier 2/Stage II/Japan 2001 (Tier 2) equivalent emission standards.

NOTE: Power Shift models show speeds only, not drawbar pull.

NOTE: Track-Type Tractor weights do not include blades until 1967.

Track-Type Tractors (cont'd)

Model	Product Ident. No. Prefix	Years Built	Horse-power FW/ Drawbar	Approx. Machine Weight kg (lb)	Gauge m (ft) and Width m (ft)	Length m (ft) and Height m (ft)	Transmission	Rated Drawbar Pull — kg (lb) and Forward Speed — km/h (mph)					
								1st	2nd	3rd	4th	5th	6th
								D4H LGP (JPN)	3AC*	89-90	95/—	11 476 (25,300)	2.00 (6'7") 2.76 (9'1")
D4H LGP (JPN)	9GJ	92-96	105/—	12 440 (27,368)	2.00 (6'7") 2.76 (9'1")	3.718 (10'0") 3.04 (10'0")	PS			10.2 (6.4)			
D4H XL (JPN)	8PS	92-96	105/—	11 786 (25,929)	1.77 (5'10") 2.28 (7'6")	3.446 (11'4") 2.99 (9'10")	PS	3.4 (2.1)	6.0 (3.7)	10.2 (6.4)			
D5	81H	67-67	93/75	8300 (18,200)	1.52 (5'0") 2.02 (6'8")	3.89 (12'9") 2.00 (8'7")	DD	7870 (17,330) (2.3)	4910 (10,820) (2.9)	3330 (7320) (3.6)	2230 (4920) (4.4)	1440 (3170) (5.5)	
D5	82H	67-67	93/75	8400 (18,600)	1.88 (6'2") 2.38 (7'10")	3.89 (12'9") 2.00 (8'7")	DD	7870 (17,330) (1.7)	4910 (10,820) (2.6)	3330 (7320) (3.6)	2230 (4920) (5.0)	1440 (3170) (6.9)	
D5	83H	67-67	93/—	8500 (18,800)	1.52 (5'0") 2.02 (6'8")	3.89 (12'9") 2.64 (8'8")	PS		2.7 (1.7)	4.2 (2.6)	5.8 (3.6)	8.0 (5.0)	11.1 (6.9)
D5	84H	67-67	93/—	8700 (19,200)	1.88 (6'2") 2.38 (7'10")	3.89 (12'9") 2.64 (8'8")	PS		3.6 (2.2)	6.1 (3.8)	10.1 (6.3)		
D5	98J	67-77	105	11 290 (24,400)	1.52 (5'0") 2.02 (6'8")	3.89 (12'9") 2.74 (9'0")	DD	8770 (19,340) (2.5)	5500 (12,130) (3.0)	3750 (8270) (3.5)	2540 (4.0)	1660 (4.6)	9.0 (5.6)
D5	93J	67-77	105	11 290 (24,400)	1.52 (5'0") 2.02 (6'8")	3.89 (12'9") 2.74 (9'0")	DD	8770 (19,340) (1.7)	5500 (12,130) (2.6)	3750 (8270) (3.6)	2540 (5.0)	1660 (6.9)	
D5	94J	66-77	105	11 390 (25,100)	1.88 (6'2") 2.38 (7'10")	3.89 (12'9") 2.74 (9'0")	DD	8770 (19,340) (1.7)	5500 (12,130) (2.6)	3750 (8270) (3.6)	2540 (5.0)	1660 (6.9)	
D5	95J	66-77	105	11 290 (24,900)	1.52 (5'0") 2.02 (6'8")	3.89 (12'9") 2.74 (9'0")	PS		2.7 (1.7)	4.2 (2.6)	5.8 (3.6)	8.0 (5.0)	11.1 (6.9)
D5	96J	66-77	105	11 600 (25,600)	1.88 (6'2") 2.38 (7'10")	3.89 (12'9") 2.74 (9'0")	PS						

\*D4H models prior to Series II. Product identification number prefix still in use for current product.

NOTE: Power Shift models show speeds only, not drawbar pull.

NOTE: Track-Type Tractor weights do not include blades until 1967.

Track-Type Tractors (cont'd)

Model	Product Ident. No. Prefix	Years Built	Horse-power FW/ Drawbar	Approx. Machine Weight kg (lb)	Gauge m (ft) and Width m (ft)	Length m (ft) and Height m (ft)	Transmission	Rated Drawbar Pull — kg (lb) and Forward Speed — km/h (mph)					
								1st	2nd	3rd	4th	5th	6th
D5B	25X	77-84	105/—	11 619 (25,615)	1.88 (6'2") 3.15 (10'4")	4.60 (15'1") 2.77 (9'1")	PS	3.5 (2.2)	6.1 (3.8)	10.1 (6.3)			
D5B	23X	77-82	105/—	11 283 (24,875)	1.88 (6'2") 3.15 (10'4")	4.60 (15'1") 2.77 (9'1")	DD	8060 (17,770)	5030 (11,100)	3410 (7520)	2290 (5060)	1480 (3260)	
D5C		91-93	90	8460 (18,650)	1.54 (5'1") 2.01 (6'7")		PS	3.5 (2.2)	6.3 (3.9)	10.0 (6.2)			
D5C Series III		93-01	90	8490 (18,710)	1.55 (5'1") 2.00 (6'7")	4.07 (13'4") 2.74 (9'0")	HYS		0-9.0 (0-5.6)				
D5C XL Series III		93-01	90	8820 (19,450)	1.55 (5'1") 2.06 (6'9")	4.32 (14'2") 2.74 (9'0")	HYS		0-9.0 (0-5.6)				
D5C LGP		91-93	90	8987 (19,800)	1.72 (5'8") 2.38 (7'10")		PS	3.5 (2.2)	6.3 (3.9)	10.0 (6.2)			
D5C LGP Series III		93-01	90	8970 (19,780)	1.73 (5'8") 2.39 (7'10")	4.07 (13'4") 2.74 (9'0")	HYS		0-9.0 (0-5.6)				
D5E		-99	105	11 700 (25,800)	1.52 (5'0")	3.88 (12'8")	DD	8770 (19,340)	5500 (12,130)	3750 (8270)	2450 (5600)	1660 (3660)	
D5G XL	FDH	01-03	90	8863 (19,540)	1.55 (5'1") 2.06 (6'9")	4.34 (14'3") 2.73 (8'11")	HYS		0-9.0 (0-5.6)				
D5G XL*	WGB	03-07	90	8919 (19,662)	1.55 (5'1") 2.06 (6'9")	4.34 (14'3") 2.73 (8'11")	HYS		0-9.0 (0-5.6)				
D5G LGP	FDW	01-03	90	9207 (20,298)	1.73 (5'8") 2.39 (7'10")	4.25 (13'11") 2.73 (8'11")	HYS		0-9.0 (0-5.6)				
D5G LGP*	RKG	03-07	90	9269 (20,434)	1.73 (5'8") 2.39 (7'10")	4.25 (13'11") 2.73 (8'11")	HYS		0-9.0 (0-5.6)				

\*Meets Tier 2/Stage II/Japan 2001 (Tier 2) equivalent emission standards.

NOTE: Power Shift models show speeds only, not drawbar pull.

NOTE: Track-Type Tractor weights do not include blades until 1967.



Track-Type Tractors (cont'd)

Model	Product Ident. No. Prefix	Years Built	Horse-power FW/ Drawbar	Approx. Machine Weight kg (lb)	Gauge m (ft) and Width m (ft)	Length m (ft) and Height m (ft)	Transmission	Rated Drawbar Pull — kg (lb) and Forward Speed — km/h (mph)						
								1st	2nd	3rd	4th	5th	6th	
D5H (FR)	8RC*	85-90	120/—	12 144 (26,772)	1.8 (5'11")	3.6 (11'10")	PS	—	—	—				
					2.21 (7'3")	2.93 (9'7")		3.3 (2.1)	5.9 (3.7)	10.0 (6.2)				
D5H (FR)	8RC	91-96	120/—	13 250 (29,200)	1.8 (5'11")	3.6 (11'10")	DD							
					2.31 (7'7")	3.0 (9'10")		3.3 (2.1)	5.9 (3.7)	10.0 (6.2)				
D5H (FR)	7NC*	85-90	120/—	12 212 (26,922)	1.8 (5'11")	3.6 (11'10")	DD	9140 (20,150)	7005 (15,440)	5190 (11,440)	3835 (8450)	2785 (6140)	1950 (4300)	
					2.21 (7'3")	2.93 (9'7")		2.7 (1.7)	3.4 (2.1)	4.5 (2.8)	5.8 (3.6)	7.6 (4.7)	10.0 (6.2)	
D5H (FR)	7NC	91-96	120/—	13 250 (29,200)	1.8 (5'11")	3.6 (11'10")	DD	9140 (20,150)	7005 (15,440)	5190 (11,440)	3835 (8450)	2785 (6140)	1950 (4300)	
					2.31 (7'7")	3.0 (9'10")		2.7 (1.7)	3.4 (2.1)	4.5 (2.8)	5.8 (3.6)	7.6 (4.7)	10.0 (6.2)	
D5H LGP (FR)	1DD*	86-90	120/—	14 685 (32,380)	2.16 (7'1")	4.129 (13'7")	PS							
					3.02 (9'11")	3.069 (10'1")		3.3 (2.1)	5.9 (3.7)	10.0 (6.2)				
D5H LGP (FR)	1DD	91-96	130/—	16 200 (35,700)	2.16 (7'1")	4.133 (13'7")	PS							
					3.02 (9'11")	3.135 (10'3")		3.3 (2.1)	5.9 (3.7)	10.0 (6.2)				
D5H LGP (FR)	9HC*	85-90	120/—	14 878 (32,800)	2.16 (7'1")	4.129 (13'7")	DD	9140 (20,150)	7005 (15,440)	5190 (11,440)	3835 (8450)	2785 (6140)	1950 (4300)	
					3.02 (9'11")	3.069 (10'1")		2.7 (1.7)	3.4 (2.1)	4.5 (2.8)	5.8 (3.6)	7.6 (4.7)	10.0 (6.2)	
D5H LGP (FR)	9HC	91-96	130/—	16 200 (35,700)	2.16 (7'1")	4.133 (13'7")	DD	10 061 (22,181)	7725 (17,031)	5738 (12,650)	4256 (9384)	3109 (6855)	2195 (4840)	
					3.02 (9'11")	3.135 (10'3")		2.6 (1.6)	3.4 (2.1)	4.5 (2.7)	5.8 (3.6)	7.5 (4.7)	9.9 (6.2)	
D5H (JPN)	3MD*	86-90	120/—	12 144 (26,772)	1.8 (5'11")	3.6 (11'10")	PS							
					2.21 (7'3")	2.93 (9'7")		3.3 (2.1)	5.9 (3.7)	10.0 (6.2)				
D5H (JPN)	3MD	91-96	120/—	13 250 (29,200)	1.8 (5'11")	3.6 (11'10")	PS							
					2.31 (7'7")	3.0 (9'10")		3.3 (2.1)	5.9 (3.7)	10.0 (6.2)				
D5H (JPN)	1YD*	86-90	120/—	12 212 (26,922)	1.8 (5'11")	3.6 (11'10")	DD	9140 (20,150)	7005 (15,440)	5190 (11,440)	3835 (8450)	2785 (6140)	1950 (4300)	
					2.21 (7'3")	2.93 (9'7")		2.7 (1.7)	3.4 (2.1)	4.5 (2.8)	5.8 (3.6)	7.6 (4.7)	10.0 (6.2)	

\*D5H models prior to Series II. Product identification number prefix still in use for current product.

NOTE: Power Shift models show speeds only, not drawbar pull.

NOTE: Track-Type Tractor weights do not include blades until 1967.

Track-Type Tractors (cont'd)

Model	Product Ident. No. Prefix	Years Built	Horse-power FW/ Drawbar	Approx. Machine Weight kg (lb)	Gauge m (ft) and Width m (ft)	Length m (ft) and Height m (ft)	Transmission	Rated Drawbar Pull — kg (lb) and Forward Speed — km/h (mph)					
								1st	2nd	3rd	4th	5th	6th
								D5H (JPN)	1YD*	91-96	120/—	13 250 (29,200)	1.8 (5'11")
D5H LGP (JPN)	4KD*	86-90	120/—	14 685 (32,380)	2.31 (7'7")	3.0 (9'10")	PS	2.7 (1.7)	3.4 (2.1)	4.5 (2.8)	5.8 (3.6)	7.6 (4.7)	10.0 (6.2)
D5H LGP (JPN)	4KD	91-96	130/—	16 200 (35,700)	2.16 (7'1")	4.129 (13'7")	PS	3.02 (2.1)	3.069 (3.6)	10.0 (6.2)			
D5H LGP (JPN)	2SD*	86-90	120/—	14 878 (32,800)	2.16 (7'1")	4.129 (13'7")	DD	9140 (20,150)	7005 (15,440)	5190 (11,440)	3835 (8450)	2785 (6140)	1950 (4300)
D5H LGP (JPN)	2SD	91-96	130/—	16 200 (35,700)	2.16 (7'1")	4.133 (13'7")	DD	2.7 (1.7)	3.4 (2.1)	4.5 (2.8)	5.8 (3.6)	7.6 (4.7)	10.0 (6.2)
D5H XL (FR)	8RJ	92-96	130/—	13 900 (30,600)	1.89 (6'2")	3.606 (11'10")	PS	10 061 (22,181)	7725 (17,031)	5738 (12,650)	4256 (9384)	3109 (6855)	2195 (4840)
D5M XL (FR)	4BR	96-02	82/110	12 250 (27,006)	2.49 (8'2")	3.08 (9'11")	PS	3.3 (2.1)	5.9 (3.7)	10.0 (6.2)			
D5M XL (FR)	6GN	96-02	82/110	12 250 (27,006)	1.77 (5'10")	3.544 (11'8")	PS	22 347 (49,264)	12 166 (26,821)	6745 (14,870)			
D5M LGP (FR)	3DR	96-02	82/110	13 100 (28,880)	2.33** (7'8")**	3.002*** (9'10")***	PS	3.27 (2.03)	5.81 (3.61)	9.93 (6.17)			
D5M LGP (FR)	3CR	96-02	82/110	13 100 (28,880)	2.00 (6'7")	3.72 (12'2")	PS	22 347 (49,264)	12 166 (26,821)	6745 (14,870)			
					2.76** (9'1")**	3.046*** (10'0")***		3.27 (2.03)	5.81 (3.61)	9.93 (6.17)			
					2.76** (9'1")**	3.046*** (10'0")***		3.27 (2.03)	5.81 (3.61)	9.93 (6.17)			

\*D5H models prior to Series II. Product identification number prefix still in use for current product.  
 \*\*Width without blade and with standard shoes.  
 \*\*\*Height with ROPS cab.  
 NOTE: Power Shift models show speeds only, not drawbar pull.  
 NOTE: Track-Type Tractor weights do not include blades until 1967.

Track-Type Tractors (cont'd)

Model	Product Ident. No. Prefix	Years Built	Horse-power FW/ Drawbar	Approx. Machine Weight kg (lb)	Gauge m (ft) and Width m (ft)	Length m (ft) and Height m (ft)	Transmission	Rated Drawbar Pull — kg (lb) and Forward Speed — km/h (mph)					
								1st	2nd	3rd	4th	5th	6th
								D6	4R	47-59	85	8042 (17,730)	1.88 (6'2") 1.52 (5'0")
D6	9U	47-59	93/75	8153 (17,975)	1.88 (6'2") 1.52 (5'0")	3.75 (12'4") 1.91 (6'3")	DD	8618 (19,000)	5534 (12,200)	3837 (8460)	2617 (5770)	1842 (4060)	
D6B	37A	59-67	93/75	8130 (17,930)	1.52 (5'0") 2.02 (6'8")	3.85 (12'9") 1.91 (6'3")	DD						
D6B	44A	59-67	93/75	8300 (18,300)	1.88 (6'2") 2.38 (7'10")	3.85 (12'9") 1.91 (6'3")	DD	7820 (16,240)	4940 (10,900)	3220 (7090)	2120 (4670)	1450 (3190)	
D6C	74A	63-67	120	10 400 (23,000)	1.88 (6'2") 2.38 (7'9")	3.95 (13'0") 1.92 (6'4")	DD	12 050 (26,540)	8020 (17,670)	5300 (11,690)	3360 (7400)	2030 (4470)	
D6C	76A	63-67	120	10 700 (23,500)	1.88 (6'2") 2.38 (7'9")	3.95 (13'0") 1.92 (6'4")	PS						
D6C	10K	67-76	140	13 880 (30,600)	1.88 (6'2") 2.38 (7'9")	3.73 (12'3") 2.87 (9'5")	PS						
D6 LGP	69U	72-77	140	17 010 (37,500)	2.11 (6'11") 3.02 (9'11")	3.94 (12'11") 2.97 (9'9")	PS						
D6C	99J	67-76	140	14 243 (31,400)	1.88 (6'2") 2.38 (7'9")	3.73 (12'3") 2.87 (9'5")	DD	11 500 (25,360)	7750 (17,090)	5180 (11,420)	3350 (7380)	2090 (4610)	
D6C LGP	69U	72-77	140	13 835 (30,500)	2.11 (6'11") 3.02 (9'11")	2.97 (9'9") 3.94 (12'11")	PS						

NOTE: Power Shift models show speeds only, not drawbar pull.  
 NOTE: Track-Type Tractor weights do not include blades until 1967.

Track-Type Tractors (cont'd)

Model	Product Ident. No. Prefix	Years Built	Horsepower FW/ Drawbar	Approx. Machine Weight kg (lb)	Gauge m (ft) and Width m (ft)	Length m (ft) and Height m (ft)	Transmission	Rated Drawbar Pull — kg (lb) and Forward Speed — km/h (mph)					
								1st	2nd	3rd	4th	5th	6th
								D6D	3X	77-86	140	14 290 (31,500)	1.88 (6'2") 2.36 (7'9")
D6D	4X	77-86	140	14 290 (31,500)	1.88 (6'2")	3.73 (12'3")	PS	1.7 (2.7)	4.0 (2.5)	5.6 (3.5)	7.9 (4.9)	11.1 (6.9)	
D6D LGP	6X	77-86	140	17 370 (38,300)	2.1 (6'11")	3.94 (12'1")	PS	4.0 (2.5)	6.9 (4.3)	10.8 (6.7)			
D6H	4RC*	85-90	165/—	16 950 (37,367)	1.88 (6'2") 2.64 (8'8")	4.069 (13'4") 3.114 (10'3")	PS	3.8 (2.4)	6.5 (4.0)	11.3 (7.0)			
D6H	8KB	85-88	165/—	16 954 (37,377)	1.88 (6'2") 2.64 (8'8")	4.069 (13'4") 3.114 (10'3")	DD	12 500 (27,560)	9520 (20,990)	7140 (15,740)	5440 (11,990)	4010 (8840)	2820 (6220)
D6H	3ZF*	88-90	165/—	17 055 (37,599)	1.88 (6'2") 2.64 (8'8")	4.069 (13'4") 3.114 (10'3")	PS/DS	2.7 (1.7)	3.5 (2.2)	4.6 (2.9)	5.8 (3.6)	7.6 (4.7)	10.0 (6.2)
D6H LGP	6FC*	87-90	165/—	19 555 (43,111)	2.225 (7'4") 3.43 (11'3")	4.493 (14'9") 3.164 (10'5")	PS	3.8 (2.4)	6.5 (4.0)	11.3 (7.0)			
D6H LGP	3YG*	88-90	165/—	19 527 (43,049)	2.225 (7'4") 3.43 (11'3")	4.493 (14'9") 3.164 (10'5")	PS/DS	3.8 (2.4)	6.5 (4.0)	11.3 (7.0)			
D6H (JPN)	2KD*	86-90	165/—	16 950 (37,367)	1.88 (6'2") 2.64 (8'8")	4.069 (13'4") 3.114 (10'3")	PS	3.8 (2.4)	6.5 (4.0)	11.3 (7.0)			
D6H (DS)	32F (E. Peoria) 4YF (Sagami) 6CF (Grenoble)	92-96	123/165	18 111 (39,928)	1.88 (6'2") 3.36 (11'0")	4.07 (13'4") 3.12 (10'3")	PS	3.8 (2.3)	6.6 (4.1)	11.4 (7.1)			

\*D6H models prior to Series II. Product identification number prefix still in use for current product.

NOTE: Power Shift models show speeds only, not drawbar pull.

NOTE: Track-Type Tractor weights do not include blades until 1967.

Track-Type Tractors (cont'd)

Model	Product Ident. No. Prefix	Years Built	Horse-power FW/ Drawbar	Approx. Machine Weight kg (lb)	Gauge m (ft) and Width m (ft)	Length m (ft) and Height m (ft)	Transmission	Rated Drawbar Pull — kg (lb) and Forward Speed — km/h (mph)						
								1st	2nd	3rd	4th	5th	6th	
D6H (CB)	4RC	92-96	123/165	17 997 (39,676)	1.88	4.07	PS	3.8 (2.3)	6.6 (4.1)	11.4 (7.1)				
	(E. Peoria) 2KD				(6'2")	(13'4")					3.36	3.12		
	(Sagami) 4LG				(11'0")	(10'3")								
D6H XL (DS)	9KJ	92-96	130/175	19 080 (42,063)	1.88	4.07	PS	3.8 (2.3)	6.6 (4.1)	11.4 (7.1)				
	(E. Peoria) 8SK				(6'2")	(13'4")					3.36	3.12		
	(Sagami) 9LK				(11'0")	(10'3")								
D6H XL (CB)	8ZJ	92-96	130/175	18 966 (41,811)	1.88	4.07	PS	3.8 (2.3)	6.6 (4.1)	11.4 (7.1)				
	(E. Peoria) 9RK				(6'2")	(13'4")					3.36	3.12		
	(Sagami) 8KK				(11'0")	(10'3")								
D6H XR (DS)	6CK	92-96	130/175	18 799 (41,444)	1.88	4.22	PS	3.8 (2.3)	6.6 (4.1)	11.4 (7.1)				
	(E. Peoria) 2TL				(6'2")	(13'10")					3.36	3.12		
	(Sagami) 1YL				(11'0")	(10'3")								
D6H XR (CB)	5KK	92-96	130/175	18 799 (41,444)	1.88	4.22	PS	3.8 (2.3)	6.6 (4.1)	11.4 (7.1)				
	(E. Peoria) 7ZK				(6'2")	(13'10")					3.36	3.12		
	(Sagami) 2BL				(11'0")	(10'3")								
D6H LGP (DS)	3YG	92-96	134/180	20 486 (45,163)	2.24	4.49	PS	3.8 (2.3)	6.6 (4.1)	11.4 (7.1)				
	(E. Peoria) 4GG				(7'3")	(14'9")					4.0	3.17		
	(Sagami) 5HF				(13'1")	(10'5")								
D6H LGP (CB)	6FC	92-96	134/180	20 486 (45,163)	2.24	4.49	PS	3.8 (2.3)	6.6 (4.1)	11.4 (7.1)				
	(E. Peoria) 1KD				(7'3")	(14'9")					4.0	3.17		
	(Sagami) 2TG				(13'1")	(10'5")								
D6H (JPN)	3ED*	86-92	165/—	16 954 (37,377)	1.88	4.069	DD	12 500 (27,560)	9520 (20,990)	7140 (15,740)	5440 (11,990)	4010 (8840)	2820 (6220)	
					2.64 (8'8")	3.114 (10'3")		2.7 (1.7)	3.5 (2.2)	4.6 (2.9)	5.8 (3.6)	7.6 (4.7)	10.0 (6.2)	
D6H (JPN)	4YF*	88-90	165/—	17 055 (37,599)	1.88	4.069	PS/DS	3.8 (2.4)	6.5 (4.0)	11.3 (7.0)				
						2.64 (8'8")					3.114 (10'3")			

\*D6H models prior to Series II. Product identification number prefix still in use for current product.

NOTE: Power Shift models show speeds only, not drawbar pull.

NOTE: Track-Type Tractor weights do not include blades until 1967.

Track-Type Tractors (cont'd)

Model	Product Ident. No. Prefix	Years Built	Horse-power FW/ Drawbar	Approx. Machine Weight kg (lb)	Gauge m (ft) and Width m (ft)	Length m (ft) and Height m (ft)	Transmission	Rated Drawbar Pull — kg (lb) and Forward Speed — km/h (mph)					
								1st	2nd	3rd	4th	5th	6th
D6H LGP (JPN)	1KD*	86-90	165/—	19 555 (43,111)	2.225 (7'4") 3.43 (11'3")	4.493 (14'9") 3.164 (10'5")	PS	3.8 (2.4)	6.5 (4.0)	11.3 (7.0)			
D6H LGP (JPN)	8FC*	86-90	165/—	19 676 (43,380)	2.225 (7'4") 3.43 (11'3")	4.485 (14'9") 3.164 (10'5")	DD	12 500 (27,560)	9520 (20,990)	7140 (15,740)	5440 (11,990)	4010 (8840)	2820 (6220)
D6H LGP (JPN)	4GG*	88-90	165/—	19 527 (43,049)	2.225 (7'4") 3.43 (11'3")	4.493 (14'9") 3.164 (10'5")	PS/DS	2.7 (1.7)	3.5 (2.2)	4.6 (2.9)	5.8 (3.6)	7.6 (4.7)	10.0 (6.2)
D6H (FR)	4LG*	87-90	165/—	16 950 (37,367)	1.88 (6'2") 2.64 (8'8")	4.069 (13'4") 3.114 (10'3")	PS	3.8 (2.4)	6.5 (4.0)	11.3 (7.0)			
D6H (FR)	1FJ*	88-90	165/—	16 954 (37,377)	1.88 (6'2") 2.64 (8'8")	4.069 (13'4") 3.114 (10'3")	DD	12 500 (27,560)	9520 (20,990)	7140 (15,740)	5440 (11,990)	4010 (8840)	2820 (6220)
D6H (FR)	6CF*	88-90	165/—	17 055 (37,599)	1.88 (6'2") 2.64 (8'8")	4.069 (13'4") 3.114 (10'3")	PS/DS	2.7 (1.7)	3.5 (2.2)	4.6 (2.9)	5.8 (3.6)	7.6 (4.7)	10.0 (6.2)
D6H LGP (FR)	2TG*	87-90	165/—	19 555 (43,111)	2.225 (7'4") 3.43 (11'3")	4.493 (14'9") 3.164 (10'5")	PS	3.8 (2.4)	6.5 (4.0)	11.3 (7.0)			
D6H LGP (FR)	5HF*	88-90	165/—	19 527 (43,049)	2.225 (7'4") 3.43 (11'3")	4.493 (14'9") 3.164 (10'5")	PS/DS	3.8 (2.4)	6.5 (4.0)	11.3 (7.0)			
D6H (SCOT)	7PC	86-87	165/—	16 950 (37,367)	1.88 (6'2") 2.64 (8'8")	4.069 (13'4") 3.114 (10'3")	PS	3.8 (2.4)	6.5 (4.0)	11.3 (7.0)			
D6H LGP (SCOT)	8YC	86-87	165/—	19 555 (43,111)	2.225 (7'4") 3.43 (11'3")	4.493 (14'9") 3.164 (10'5")	PS	3.8 (2.4)	6.5 (4.0)	11.3 (7.0)			
D6K XL	FBH	05-14	125	12 886 (28,409)	1.77 (5'10") 2.33 (7'8")	2.65 (8'8") 2.91 (9'7")	Hystat						
D6K LGP	DHA	05-13	125	13 467 (29,690)	2 (6'7") 2.76 (9'1")	2.65 (8'8") 2.91 (9'7")	Hystat						

\*D6H models prior to Series II. Product identification number prefix still in use for current product.

NOTE: Power Shift models show speeds only, not drawbar pull.

NOTE: Track-Type Tractor weights do not include blades until 1967.

Track-Type Tractors (cont'd)

Model	Product Ident. No. Prefix	Years Built	Horse-power FW/ Drawbar	Approx. Machine Weight kg (lb)	Gauge m (ft) and Width m (ft)	Length m (ft) and Height m (ft)	Transmission	Rated Drawbar Pull — kg (lb) and Forward Speed — km/h (mph)					
								1st	2nd	3rd	4th	5th	6th
D6R STD CB (US)	2YN	95-02	165/—	18 100 (40,000)	1.88 (6'2") 2.64 (8'8")	4.08 (13'4") 3.20 (10'6")	PS	4.0 (2.5)	7.1 (4.4)	12.4 (7.7)			
D6R STD CB (BRAZIL)	9ZS	97-02	165/—	18 100 (40,000)	1.88 (6'2") 2.64 (8'8")	4.08 (13'4") 3.20 (10'6")	PS	4.0 (2.5)	7.1 (4.4)	12.4 (7.7)			
D6R STD CB (FRANCE)	2HM	96-01	165/—	18 100 (40,000)	1.88 (6'2") 2.64 (8'8")	4.08 (13'4") 3.20 (10'6")	PS	4.0 (2.5)	7.1 (4.4)	12.4 (7.7)			
D6R STD CB (JAPAN)	6FR	96-02	165/—	18 100 (40,000)	1.88 (6'2") 2.64 (8'8")	4.08 (13'4") 3.20 (10'6")	PS	4.0 (2.5)	7.1 (4.4)	12.4 (7.7)			
D6R STD DS (US)	3ZN	95-02	165/—	18 300 (40,400)	1.88 (6'2") 2.64 (8'8")	4.08 (13'4") 3.20 (10'6")	PS	3.9 (2.4)	6.8 (4.2)	11.9 (7.6)			
D6R STD DS (BRAZIL)	1RW	97-02	165/—	18 300 (40,400)	1.88 (6'2") 2.64 (8'8")	4.08 (13'4") 3.20 (10'6")	PS	3.9 (2.4)	6.8 (4.2)	11.9 (7.6)			
D6R STD DS (FRANCE)	4FM	96-01	165/—	18 300 (40,400)	1.88 (6'2") 2.64 (8'8")	4.08 (13'4") 3.20 (10'6")	PS	3.9 (2.4)	6.8 (4.2)	11.9 (7.6)			
D6R STD DS (JAPAN)	5PR	97-02	165/—	18 300 (40,400)	1.88 (6'2") 2.64 (8'8")	4.08 (13'4") 3.20 (10'6")	PS	3.9 (2.4)	6.8 (4.2)	11.9 (7.6)			
D6R XL CB (US)	4MN	96-02	175/—	19 000 (41,900)	1.88 (6'2") 2.64 (8'8")	4.08 (13'4") 3.20 (10'6")	PS	4.0 (2.5)	7.1 (4.4)	12.4 (7.7)			
D6R XL CB (BRAZIL)	6MR	97-02	175/—	19 000 (41,900)	1.88 (6'2") 2.64 (8'8")	4.08 (13'4") 3.20 (10'6")	PS	4.0 (2.5)	7.1 (4.4)	12.4 (7.7)			
D6R XL CB (FRANCE)	4JR	96-01	175/—	19 000 (41,900)	1.88 (6'2") 2.64 (8'8")	4.08 (13'4") 3.20 (10'6")	PS	4.0 (2.5)	7.1 (4.4)	12.4 (7.7)			
D6R XL CB (JAPAN)	4WR	97-02	175/—	19 000 (41,900)	1.88 (6'2") 2.64 (8'8")	4.08 (13'4") 3.20 (10'6")	PS	4.0 (2.5)	7.1 (4.4)	12.4 (7.7)			

NOTE: Power Shift models show speeds only, not drawbar pull.  
NOTE: Track-Type Tractor weights do not include blades until 1967.

Track-Type Tractors (cont'd)

Model	Product Ident. No. Prefix	Years Built	Horsepower FW/ Drawbar	Approx. Machine Weight kg (lb)	Gauge m (ft) and Width m (ft)	Length m (ft) and Height m (ft)	Transmission	Rated Drawbar Pull — kg (lb) and Forward Speed — km/h (mph)					
								1st	2nd	3rd	4th	5th	6th
D6R XL DS (US)	5LN	95-02	175/—	19 200 (42,300)	1.88 (6'2") 2.64 (8'8")	4.08 (13'4") 3.20 (10'6")	PS	3.9 (2.4)	6.8 (4.2)	11.9 (7.6)			
D6R XL DS (BRAZIL)	7GR	96-02	175/—	19 200 (42,300)	1.88 (6'2") 2.64 (8'8")	4.08 (13'4") 3.20 (10'6")	PS	3.9 (2.4)	6.8 (4.2)	11.9 (7.6)			
D6R XL DS (FRANCE)	9BM	96-01	175/—	19 200 (42,300)	1.88 (6'2") 2.64 (8'8")	4.08 (13'4") 3.20 (10'6")	PS	3.9 (2.4)	6.8 (4.2)	11.9 (7.6)			
D6R XL DS (JAPAN)	5RR	97-02	175/—	19 200 (42,300)	1.88 (6'2") 2.64 (8'8")	4.08 (13'4") 3.20 (10'6")	PS	3.9 (2.4)	6.8 (4.2)	11.9 (7.6)			
D6R XR CB (US)	6JN	95-02	175/—	18 780 (41,400)	1.88 (6'2") 2.64 (8'8")	4.22 (13'10") 3.19 (10'5")	PS	4.0 (2.5)	7.1 (4.4)	12.4 (7.7)			
D6R XR CB (FRANCE)	8XN	97-01	175/—	18 780 (41,400)	1.88 (6'2") 2.64 (8'8")	4.22 (13'10") 3.19 (10'5")	PS	4.0 (2.5)	7.1 (4.4)	12.4 (7.7)			
D6R XR CB (JAPAN)	6HR	97-02	175/—	18 780 (41,400)	1.88 (6'2") 2.64 (8'8")	4.22 (13'10") 3.19 (10'5")	PS	4.0 (2.5)	7.1 (4.4)	12.4 (7.7)			
D6R XR DS (US)	7KN	95-02	175/—	18 910 (41,700)	1.88 (6'2") 2.64 (8'8")	4.22 (13'10") 3.19 (10'5")	PS	3.9 (2.4)	6.8 (4.2)	11.9 (7.6)			
D6R XR DS (FRANCE)	9MN	97-01	175/—	18 910 (41,700)	1.88 (6'2") 2.64 (8'8")	4.22 (13'10") 3.19 (10'5")	PS	3.9 (2.4)	6.8 (4.2)	11.9 (7.6)			
D6R XR DS (JAPAN)	7DR	97-02	175/—	18 910 (41,700)	1.88 (6'2") 2.64 (8'8")	4.22 (13'10") 3.19 (10'5")	PS	3.9 (2.4)	6.8 (4.2)	11.9 (7.6)			
D6R LGP CB (US)	8LN	95-02	185/—	20 500 (45,200)	2.23 (7'3") 3.43 (11'3")	4.24 (13'11") 3.19 (10'5")	PS	4.0 (2.5)	7.1 (4.4)	12.4 (7.7)			
D6R LGP CB (FRANCE)	4HN	97-01	185/—	20 500 (45,200)	2.23 (7'3") 3.43 (11'3")	4.24 (13'11") 3.19 (10'5")	PS	4.0 (2.5)	7.1 (4.4)	12.4 (7.7)			

NOTE: Power Shift models show speeds only, not drawbar pull.  
NOTE: Track-Type Tractor weights do not include blades until 1967.



Track-Type Tractors (cont'd)

Model	Product Ident. No. Prefix	Years Built	Horse-power FW/ Drawbar	Approx. Machine Weight kg (lb)	Gauge m (ft) and Width m (ft)	Length m (ft) and Height m (ft)	Transmission	Rated Drawbar Pull — kg (lb) and Forward Speed — km/h (mph)					
								1st	2nd	3rd	4th	5th	6th
D6R LGP CB (JAPAN)	7AR	97-01	185/—	20 500 (45,200)	2.23 (7'3") 3.43 (11'3")	4.24 (13'11") 3.19 (10'5")	PS	4.0 (2.5)	7.1 (4.4)	12.4 (7.7)			
D6R LGP DS (US)	9PN	95-02	185/—	20 680 (45,600)	2.23 (7'3") 3.43 (11'3")	4.24 (13'11") 3.19 (10'5")	PS	3.9 (2.4)	6.8 (4.2)	11.9 (7.6)			
D6R LGP DS (FRANCE)	8TM	96-01	185/—	20 680 (45,600)	2.23 (7'3") 3.43 (11'3")	4.24 (13'11") 3.19 (10'5")	PS	3.9 (2.4)	6.8 (4.2)	11.9 (7.6)			
D6R LGP DS (JAPAN)	4TR	96-02	185/—	20 680 (45,600)	2.23 (7'3") 3.43 (11'3")	4.24 (13'11") 3.19 (10'5")	PS	3.9 (2.4)	6.8 (4.2)	11.9 (7.6)			
D6R LGP DD (JAPAN)	6GR	95-02	185/—	20 680 (45,600)	2.23 (7'3") 3.43 (11'3")	4.24 (13'11") 3.19 (10'5")	PS	3.4 (2.1)	5.9 (3.7)	10.4 (6.5)			
D6M XL (FR)	9ZM	96-02	104/140	15 530 (34,240)	1.89 (6'2") 2.49* (8'2")*	3.74 (12'3") 3.08** (10'1")**	PS	30 493 (67,222)	16 643 (36,689)	9211 (20,306)			
D6M XL (FR)	3WN	96-02	104/140	15 530 (34,240)	1.89 (6'2") 2.49* (8'2")*	3.74 (12'3") 3.08** (10'1")**	PS	30 493 (67,222)	16 643 (36,689)	9211 (20,306)			
D6M LGP (FR)	2RN	96-02	104/140	16 930 (37,320)	2.16 (7'1") 3.02* (9'11")*	4.146 (13'7") 3.194** (10'6")**	PS	30 493 (67,222)	16 643 (36,689)	9211 (20,306)			
D6M LGP (FR)	4JN	96-02	104/140	16 930 (37,320)	2.16 (7'1") 3.02* (9'11")*	4.146 (13'7") 3.194** (10'6")**	PS	30 493 (67,222)	16 643 (36,689)	9211 (20,306)			
D6R SII STD CB (FTC) (US)	AEM	02-05	123/165	17 826 (39,300)	1.88 (6'2") 2.64 (8'8")	3.86 (12'8") 3.2 (10'6")	PS	3.8 (2.4)	6.6 (4.1)	11.5 (7.2)			
D6R SII STD CB (FTC) (BRAZIL)	BRJ	02-06	123/165	17 826 (39,300)	1.88 (6'2") 2.64 (8'8")	3.86 (12'8") 3.2 (10'6")	PS	3.8 (2.4)	6.6 (4.1)	11.5 (7.2)			
D6R SII STD CB (FTC) (FRANCE)	BLE	01-05	123/165	17 826 (39,300)	1.88 (6'2") 2.64 (8'8")	3.86 (12'8") 3.2 (10'6")	PS	3.8 (2.4)	6.6 (4.1)	11.5 (7.2)			

\*Width without blade and with standard shoes.

\*\*Height with ROPS cab.

NOTE: Power Shift models show speeds only, not drawbar pull.

NOTE: Track-Type Tractor weights do not include blades until 1967.

Track-Type Tractors (cont'd)

Model	Product Ident. No. Prefix	Years Built	Horse-power FW/ Drawbar	Approx. Machine Weight kg (lb)	Gauge m (ft) and Width m (ft)	Length m (ft) and Height m (ft)	Transmission	Rated Drawbar Pull — kg (lb) and Forward Speed — km/h (mph)					
								1st	2nd	3rd	4th	5th	6th
D6R SII STD CB (FTC) (JAPAN)	BMK	01-06	123/165	17 826 (39,300)	1.88 (6'2") 2.64 (8'8")	3.86 (12'8") 3.2 (10'6")	PS	3.8 (2.4)	6.6 (4.1)	11.5 (7.2)			
D6R SII STD DS (US)	AFM	01-05	123/165	18 099 (39,900)	1.88 (6'2") 2.64 (8'8")	3.86 (12'8") 3.2 (10'6")	PS	3.8 (2.3)	6.6 (4.1)	11.4 (7.1)			
D6R SII STD DS (BRAZIL)	BPM	03-06	123/165	18 099 (39,900)	1.88 (6'2") 2.64 (8'8")	3.86 (12'8") 3.2 (10'6")	PS	3.8 (2.3)	6.6 (4.1)	11.4 (7.1)			
D6R SII STD DS (FRANCE)	BLT	02-05	123/165	18 099 (39,900)	1.88 (6'2") 2.64 (8'8")	3.86 (12'8") 3.2 (10'6")	PS	3.8 (2.3)	6.6 (4.1)	11.4 (7.1)			
D6R SII STD DS (JAPAN)	BNL	01-06	123/165	18 099 (39,900)	1.88 (6'2") 2.64 (8'8")	3.86 (12'8") 3.2 (10'6")	PS	3.8 (2.3)	6.6 (4.1)	11.4 (7.1)			
D6R SII XL CB (FTC) (US)	AGM	00-05	138/185	18 711 (41,250)	1.88 (6'2") 2.64 (8'8")	3.86 (12'8") 3.2 (10'6")	PS	3.8 (2.4)	6.6 (4.1)	11.5 (7.2)			
D6R SII XL CB (FTC) (BRAZIL)	CAD	02-06	138/185	18 711 (41,250)	1.88 (6'2") 2.64 (8'8")	3.86 (12'8") 3.2 (10'6")	PS	3.8 (2.4)	6.6 (4.1)	11.5 (7.2)			
D6R SII XL CB (FTC) (FRANCE)	BMJ	02-05	138/185	18 711 (41,250)	1.88 (6'2") 2.64 (8'8")	3.86 (12'8") 3.2 (10'6")	PS	3.8 (2.4)	6.6 (4.1)	11.5 (7.2)			
D6R SII XL CB (FTC) (JAPAN)	BPS	01-06	138/185	18 711 (41,250)	1.88 (6'2") 2.64 (8'8")	3.86 (12'8") 3.2 (10'6")	PS	3.8 (2.4)	6.6 (4.1)	11.5 (7.2)			
D6R SII XL DS (US)	AAX	00-05	138/185	18 847 (41,550)	1.88 (6'2") 2.64 (8'8")	3.86 (12'8") 3.2 (10'6")	PS	3.8 (2.3)	6.6 (4.1)	11.4 (7.1)			
D6R SII XL DS (BRAZIL)	FDT	02-06	138/185	18 847 (41,550)	1.88 (6'2") 2.64 (8'8")	3.86 (12'8") 3.2 (10'6")	PS	3.8 (2.3)	6.6 (4.1)	11.4 (7.1)			
D6R SII XL DS (FRANCE)	BMY	01-05	138/185	18 847 (41,550)	1.88 (6'2") 2.64 (8'8")	3.86 (12'8") 3.2 (10'6")	PS	3.8 (2.3)	6.6 (4.1)	11.4 (7.1)			

NOTE: Power Shift models show speeds only, not drawbar pull.  
 NOTE: Track-Type Tractor weights do not include blades until 1967.

## Track-Type Tractors (cont'd)

Model	Product Ident. No. Prefix	Years Built	Horse-power FW/ Drawbar	Approx. Machine Weight kg (lb)	Gauge m (ft) and Width m (ft)	Length m (ft) and Height m (ft)	Transmission	Rated Drawbar Pull — kg (lb) and Forward Speed — km/h (mph)							
								1st	2nd	3rd	4th	5th	6th		
D6R SII XL DS (JAPAN)	BRZ	01-06	138/185	18 847 (41,550)	1.88 (6'2")	3.86 (12'8")	PS								
D6R SII XW DS (US)	AEP	2001	138/185	19 550 (43,100)	2.64 (8'8")	3.2 (10'6")	PS	3.8 (2.3)	6.6 (4.1)	11.4 (7.1)					
D6R SII XW DS (FRANCE)	DAE	02-05	138/185	19 550 (43,100)	2.03 (6'8")	3.86 (12'8")	PS								
D6R SII XW DS (JAPAN)	BRE	01-06	138/185	19 550 (43,100)	2.03 (6'8")	3.86 (12'8")	PS								
D6R SII LGP CB (FTC) (US)	ACJ	01-05	138/185	20 865 (46,000)	2.23 (7'3")	4.24 (13'11")	PS								
D6R SII LGP CB (FTC) (JAPAN)	BPP	01-06	138/185	20 865 (46,000)	2.23 (7'3")	4.24 (13'11")	PS								
D6R SII LGP DS (US)	ADE	00-05	138/185	21 047 (46,400)	2.23 (7'3")	4.24 (13'11")	PS								
D6R SII LGP DS (FRANCE)	BNC	01-05	138/185	21 047 (46,400)	2.23 (7'3")	4.24 (13'11")	PS								
D6R SII LGP DS (JAPAN)	BPZ	01-06	138/185	21 047 (46,400)	2.23 (7'3")	4.24 (13'11")	PS								
D6R SIII (US) (BRAZIL)	HCD	05-07	138/185	18 326 (40,400)	1.88 (6'2")	3.86 (12'8")	PS								
D6R SIII (FRANCE)	GMT	06-07				3.20 (10'6")		3.8 (2.3)	6.6 (4.1)	11.4 (7.1)					
D6R SIII (JAPAN)	TBC	06-07				2.67 (8'9")		3.8 (2.3)	6.6 (4.1)	11.4 (7.1)					
D6R SIII XL (US)	JEK	06-10	138/185	18 326 (40,400)	1.88 (6'2")	3.86 (12'8")	PS								
D6R SIII XL (BRAZIL)	GJB	05-07	149/200	20 081 (44,270)	1.88 (6'2")	3.86 (12'8")	PS								
D6R SIII XL (FRANCE)	JDL	05-07				2.13 (7'0")		3.8 (2.3)	6.6 (4.1)	11.4 (7.1)					
D6R SIII XL (JAPAN)	LFM	06-07				2.87 (9'5")		3.8 (2.3)	6.6 (4.1)	11.4 (7.1)					
	EXL	06-12	149/200	20 081 (44,270)	1.88 (6'2")	2.87 (9'5")	PS								

NOTE: Power Shift models show speeds only, not drawbar pull.

NOTE: Track-Type Tractor weights do not include blades until 1967.

Track-Type Tractors (cont'd)

Model	Product Ident. No. Prefix	Years Built	Horse-power FW/ Drawbar	Approx. Machine Weight kg (lb)	Gauge m (ft) and Width m (ft)	Length m (ft) and Height m (ft)	Transmission	Rated Drawbar Pull — kg (lb) and Forward Speed — km/h (mph)						
								1st	2nd	3rd	4th	5th	6th	
D6R SIII XL PAT (US) (FRANCE)	HKE RFC	05-07 06-07	149/200	20 081 <b>(44,270)</b>	1.88 <b>(6'2")</b>	3.86 <b>(12'8")</b>	PS							
					2.13 <b>(7'0")</b>	3.20 <b>(10'6")</b>		3.8 <b>(2.3)</b>	6.6 <b>(4.1)</b>	11.4 <b>(7.1)</b>				
D6R SIII XW (US) (BRAZIL)	MRT DPS	05-07 06-07	149/200	20 672 <b>(45,573)</b>	2.03 <b>(6'8")</b>	3.86 <b>(12'8")</b>	PS							
					2.29 <b>(7'6")</b>	3.20 <b>(10'6")</b>		3.8 <b>(2.3)</b>	6.6 <b>(4.1)</b>	11.4 <b>(7.1)</b>				
D6R SIII XW PAT (US) (FRANCE)	HDC MTJ	05-07 05-07	149/200	20 672 <b>(45,573)</b>	2.03 <b>(6'8")</b>	3.86 <b>(12'8")</b>	PS							
					2.29 <b>(7'6")</b>	3.20 <b>(10'6")</b>		3.8 <b>(2.3)</b>	6.6 <b>(4.1)</b>	11.4 <b>(7.1)</b>				
D6R SIII XW (JAPAN)	EXW	07-09	149/200	20 672 <b>(45,573)</b>	2.03 <b>(6'8")</b>	2.87 <b>(9'5")</b>	PS	3.8 <b>(2.3)</b>	6.6 <b>(4.1)</b>	11.4 <b>(7.1)</b>				
D6R SIII LGP (US) (FRANCE)	WRG DMK	05-07 06-07	149/200	21 716 <b>(47,874)</b>	2.29 <b>(7'6")</b>	4.25 <b>(13'11")</b>	PS							
					2.29 <b>(7'6")</b>	3.25 <b>(10'8")</b>		3.8 <b>(2.3)</b>	6.6 <b>(4.1)</b>	11.4 <b>(7.1)</b>				
D6R SIII LGP (JAPAN)	LGP	06-12	149/200	21 716 <b>(47,874)</b>	2.29 <b>(7'6")</b>	3.28 <b>(10'9")</b>	PS	3.8 <b>(2.3)</b>	6.6 <b>(4.1)</b>	11.4 <b>(7.1)</b>				
D6R SIII LGP PAT (US) (FRANCE)	WCB DLM	05-07 05-07	149/200	21 716 <b>(47,874)</b>	2.29 <b>(7'6")</b>	4.25 <b>(13'11")</b>	PS							
					2.29 <b>(7'6")</b>	3.25 <b>(10'8")</b>		3.8 <b>(2.3)</b>	6.6 <b>(4.1)</b>	11.4 <b>(7.1)</b>				
D6T XL*	GMK	11-14	207	21 306 <b>(46,791)</b>	1.88 <b>(6'2")</b>	3.86 <b>(12'8")</b>	PS/DS	36 936 <b>(81,430)</b>	22 343 <b>(49,260)</b>	12 124 <b>(26,730)</b>	12 124 <b>(26,730)</b>			
					2.64 <b>(8'8")</b>	3.13 <b>(10'2")</b>		3.8 <b>(2.3)</b>	5.1 <b>(3.2)</b>	8.5 <b>(5.3)</b>	11.4 <b>(7.1)</b>			
D6T XL VPAT*	DTD	11-14	207	23 663 <b>(52,167)</b>	2.13 <b>(7'0")</b>	3.86 <b>(12'8")</b>	PS/DS	36 936 <b>(81,430)</b>	22 343 <b>(49,260)</b>	12 124 <b>(26,730)</b>	12 124 <b>(26,730)</b>			
						3.13 <b>(10'2")</b>		3.8 <b>(2.3)</b>	5.1 <b>(3.2)</b>	8.5 <b>(5.3)</b>	11.4 <b>(7.1)</b>			
D6T XW*	SLJ	11-14	207	22 191 <b>(48,922)</b>	2.03 <b>(6'8")</b>	3.86 <b>(12'8")</b>	PS/DS	36 936 <b>(81,430)</b>	22 343 <b>(49,260)</b>	12 124 <b>(26,730)</b>	12 124 <b>(26,730)</b>			
					2.95 <b>(9'8")</b>	3.13 <b>(10'2")</b>		3.8 <b>(2.3)</b>	5.1 <b>(3.2)</b>	8.5 <b>(5.3)</b>	11.4 <b>(7.1)</b>			
D6T XW VPAT*	RCW	11-14	207	24 118 <b>(53,170)</b>	2.29 <b>(7'6")</b>	4.25 <b>(13'11")</b>	PS/DS	36 936 <b>(81,430)</b>	22 343 <b>(49,260)</b>	12 124 <b>(26,730)</b>	12 124 <b>(26,730)</b>			
						3.18 <b>(10'5")</b>		3.8 <b>(2.3)</b>	5.1 <b>(3.2)</b>	8.5 <b>(5.3)</b>	11.4 <b>(7.1)</b>			
D6T LGP*	ZJB	11-14	207	24 020 <b>(52,954)</b>	2.29 <b>(7'6")</b>	4.25 <b>(13'11")</b>	PS/DS	36 936 <b>(81,430)</b>	22 343 <b>(49,260)</b>	12 124 <b>(26,730)</b>	12 124 <b>(26,730)</b>			
					3.48 <b>(11'5")</b>	3.18 <b>(10'5")</b>		3.8 <b>(2.3)</b>	5.1 <b>(3.2)</b>	8.5 <b>(5.3)</b>	11.4 <b>(7.1)</b>			
D6T LGP VPAT*	KSB	11-14	207	22 009 <b>(48,521)</b>	2.29 <b>(7'6")</b>	4.25 <b>(13'11")</b>	PS/DS	36 936 <b>(81,430)</b>	22 343 <b>(49,260)</b>	12 124 <b>(26,730)</b>	12 124 <b>(26,730)</b>			
						3.18 <b>(10'5")</b>		3.8 <b>(2.3)</b>	5.1 <b>(3.2)</b>	8.5 <b>(5.3)</b>	11.4 <b>(7.1)</b>			

\*Meets Tier 4 Interim/Stage IIIB/Japan 2011 (Tier 4 Interim) equivalent emission standards.

NOTE: Power Shift models show speeds only, not drawbar pull.

NOTE: Track-Type Tractor weights do not include blades until 1967.

Track-Type Tractors (cont'd)

Model	Product Ident. No. Prefix	Years Built	Horse-power FW/ Drawbar	Approx. Machine Weight kg (lb)	Gauge m (ft) and Width m (ft)	Length m (ft) and Height m (ft)	Transmission	Rated Drawbar Pull — kg (lb) and Forward Speed — km/h (mph)						
								1st	2nd	3rd	4th	5th	6th	
D7	3T	54-55	108/90	11 770 (25,925)	1.88 (6'2") 2.64 (8'1")	4.27 (14'0") 2.06 (6'10")	DD							
D7C	17A	55-59	128/102	11 954 (26,355)	1.88 (6'2") 2.64 (8'1")	4.26 (14'0") 2.06 (6'10")	DD	11 759 (25,900)	8045 (17,720)	4521 (11,960)	3428 (7550)	2397 (5280)		
D7D	17A	59-61	140/112	12 056 (26,555)	1.88 (6'2") 2.64 (8'1")	4.26 (14'0") 2.06 (6'10")	DD	12 300 (27,100)	8600 (18,900)	5700 (12,550)	3650 (8080)	2600 (5720)		
D7E	47A	61-68	160/128	14 787 (32,590)	1.98 (6'6") 2.56 (8'5")	4.47 (14'8") 2.30 (7'7")	DD	14 741 (32,500)	10 296 (22,700)	6803 (15,000)	4259 (9390)	3070 (6770)		
D7E	48A	61-66	160/128	14 787 (32,590)	1.98 (6'6") 2.56 (8'5")	4.47 (14'8") 2.30 (7'7")	PS							
D7E	47A	66-69	180/144	15 200 (33,500)	1.98 (6'6") 2.56 (8'5")	4.47 (14'8") 2.18 (7'2")	DD	17 140 (37,750)	11 350 (25,000)	7420 (16,340)	4540 (9990)	3180 (7010)		
D7E	48A	66-69	180	15 500 (34,000)	1.98 (6'6") 2.56 (8'5")	4.47 (14'8") 2.18 (7'2")	PS							
D7E*	TAN	10-14	235	26 055 (57,441)	1.98 (6'6") 2.88 (9'5")	4.6 (15'1") 3.36 (11'0")	E							
D7E LGP*	TJA	10-14	235	28 525 (62,886)	2.28 (7'6") 3.42 (11'3")	4.6 (15'1") 3.36 (11'0")	E							
D7F	94N	69-74	180	14 700 (32,400)	1.98 (6'6") 2.56 (8'5")	4.15 (13'8") 2.26 (7'5")	PS							
D7F	93N	69-74	180	14 700 (32,400)	1.98 (6'6") 2.56 (8'5")	4.15 (13'8") 2.26 (7'5")	DD	17 100 (37,600)	11 350 (25,000)	7450 (16,400)	4580 (10,000)	3240 (7140)		

\*Meets Tier 4 Interim/Stage IIIB/Japan 2011 (Tier 4 Interim) equivalent emission standards.

NOTE: Power Shift models show speeds only, not drawbar pull.

NOTE: Track-Type Tractor weights do not include blades until 1967.

## Track-Type Tractors (cont'd)

Model	Product Ident. No. Prefix	Years Built	Horse-power FW/ Drawbar	Approx. Machine Weight kg (lb)	Gauge m (ft) and Width m (ft)	Length m (ft) and Height m (ft)	Transmission	Rated Drawbar Pull — kg (lb) and Forward Speed — km/h (mph)						
								1st	2nd	3rd	4th	5th	6th	
								D7G	92V	77-86	200	20 090 (44,300)	1.98 (6'6")	4.19 (13'9")
D7G	91V	77-86	200	20 090 (44,300)	1.98 (6'6")	4.19 (13'9")	DD	3.7 (2.3)	6.4 (4.0)	10.0 (6.2)				
D7G (JAPAN)	65V	75-07	149/200	20 580 (45,381)	1.98 (6'6")	2.72 (8'11")	PS	17 690 (39,010)	11 730 (25,860)	7680 (16,940)	4700 (10,370)	3320 (7320)		
D7G (INDONESIA)	7MB	83-07	149/200	20 580 (45,381)	1.98 (6'6")	2.72 (8'11")	PS	2.5 (1.6)	3.7 (2.3)	5.3 (3.3)	7.8 (4.9)	10.1 (6.3)		
D7G LGP	72W	77-86	200	22 630 (52,100)	2.18 (7'2")	4.22 (13'9")	PS	3.7 (2.3)	6.4 (4.0)	10.0 (6.2)				
D7G SII (INDONESIA)	7MB	08-12	149/200	20 580 (45,381)	1.98 (6'6")	2.72 (8'11")	PS	3.7 (2.3)	6.4 (4.0)	10.0 (6.2)				
D7G SII (CHINA)	C7G	06-11	149/200	20 580 (45,381)	1.98 (6'6")	2.72 (8'11")	PS	3.7 (2.3)	6.4 (4.0)	10.0 (6.2)				
D7H (CB)	79Z (E. Peoria) 4AB (Sagami)	92-96	171/230	24 778 (54,635)	1.98 (6'6")	4.74 (15'6")	PS	3.3 (2.2)	3.28 (3.8)	10.0 (6.6)				
D7H (DS)	5BF (E. Peoria) 2RG (Sagami)	92-96	171/230	25 077 (55,295)	1.98 (6'6")	4.74 (15'6")	PS	3.5 (2.2)	6.2 (3.8)	10.6 (6.6)				
D7H LGP (CB)	80Z (E. Peoria) 5WB (Sagami)	92-96	171/230	27 065 (59,678)	2.24 (7'4")	4.74 (15'6")	PS	3.5 (2.2)	6.2 (3.8)	10.6 (6.6)				
D7H LGP (DS)	4FG (E. Peoria) 3XG (Sagami)	92-96	171/230	27 065 (59,678)	2.24 (7'4")	4.74 (15'6")	PS	3.5 (2.2)	6.2 (3.8)	10.6 (6.6)				
D7H XR (CB)	79Z (E. Peoria) 4AB (Sagami)	92-96	171/230	25 193 (55,551)	1.98 (6'6")	4.74 (15'6")	PS	3.5 (2.2)	6.2 (3.8)	10.6 (6.6)				
D7H XR (DS)	5BF (E. Peoria) 2RG (Sagami)	92-96	171/230	25 492 (56,211)	1.98 (6'6")	4.74 (15'6")	PS	3.5 (2.2)	6.2 (3.8)	10.6 (6.6)				
D7H	77Z	85-86	215	19 680 (43,380)	1.98 (6'6")	4.73 (15'6")	DD	16 834 (37,113)	12 861 (28,353)	9703 (21,390)	7436 (16,394)	5522 (12,173)	3940 (8686)	
D7H (US)	79Z*	85-90	215/—	23 647 (52,134)	1.981 (6'6")	4.619 (15'2")	PS	2.7 (1.7)	3.5 (2.2)	4.5 (2.8)	5.8 (3.6)	7.6 (4.7)	10.0 (6.2)	
					2.869 (9'5")	3.421 (11'3")		3.9 (2.4)	6.8 (4.2)	11.9 (7.4)				

\*D7H models prior to Series II. Product identification number prefix still in use for current product.

NOTE: Power Shift models show speeds only, not drawbar pull.

NOTE: Track-Type Tractor weights do not include blades until 1967.

Track-Type Tractors (cont'd)

Model	Product Ident. No. Prefix	Years Built	Horse-power FW/ Drawbar	Approx. Machine Weight kg (lb)	Gauge m (ft) and Width m (ft)	Length m (ft) and Height m (ft)	Transmission	Rated Drawbar Pull — kg (lb) and Forward Speed — km/h (mph)					
								1st	2nd	3rd	4th	5th	6th
								D7H (US)	77Z	85-90	215/—	23 570 (51,960)	1.981 (6'6")
D7H (US)	5BF*	88-90	215/—	24 351 (53,683)	1.981 (6'6")	4.624 (15'2")	PS/DS	2.7 (1.7)	3.5 (2.2)	4.6 (2.8)	5.8 (3.6)	7.6 (4.7)	10.0 (6.2)
D7H (JPN)	4AB*	86-90	215/—	23 647 (52,134)	1.981 (6'6")	4.619 (15'2")	PS	2.869 (9'5")	3.421 (11'3")	4.6 (2.8)	5.8 (3.6)	7.6 (4.7)	10.0 (6.2)
D7H (JPN)	2SB*	86-91	215/—	23 570 (51,960)	1.981 (6'6")	4.619 (15'2")	DD	16 834 (37,113)	12 861 (28,353)	9703 (21,390)	7436 (16,394)	5522 (12,173)	3940 (8686)
D7H (JPN)	2RG*	88-90	215/—	24 351 (53,683)	1.981 (6'6")	4.624 (15'2")	PS/DS	2.7 (1.7)	3.5 (2.2)	4.6 (2.8)	5.8 (3.6)	7.6 (4.7)	10.0 (6.2)
D7R LGP (JPN)	6ER	96-02	179 (240)	30 605 (67,472)	2.24 (7'4")	5.8 (19'0")	PS/DS	3.5 (2.3)	6.4 (4.0)	10.8 (6.8)			
D7H LGP (JPN)	5WB*	86-90	215/—	25 237 (55,638)	2.235 (7'4")	4.619 (15'2")	PS	3.371 (11'1")	6.8 (4.2)	11.9 (7.4)			
D7H LGP (JPN)	82Z*	86-91	215/—	25 445 (56,096)	2.235 (7'4")	4.619 (15'2")	DD	16 834 (37,113)	12 861 (28,353)	9703 (21,390)	7436 (16,394)	5522 (12,173)	3940 (8686)
D7H LGP (JPN)	3XG*	88-90	230/—	25 894 (57,086)	2.235 (7'4")	4.624 (15'2")	PS/DS	2.7 (1.7)	3.5 (2.2)	4.6 (2.8)	5.8 (3.6)	7.6 (4.7)	10.0 (6.2)
D7R STD (US)	2HR	95-01	171 (230)	27 413 (60,436)	2.0 (6'6")	6.04 (19'9")	PS/FTC	3.5 (2.3)	6.4 (4.0)	10.8 (6.8)			
D7R STD (US)	3ZR	96-02	171 (230)	27 413 (60,436)	2.0 (6'6")	6.04 (19'9")	PS/FTC	3.5 (2.3)	6.4 (4.0)	10.8 (6.8)			
D7R SII STD (JAPAN)	BRM	02-12	179/240	25 455 (56,129)	1.98 (6'6")**	2.87 (9'5")†	PS	3.52 (2.19)	6.10 (3.79)	10.54 (6.55)			
D7R SII STD (US)	AEC	00-10	179/240	25 455 (56,129)	1.98 (6'6")**	2.87 (9'5")†	PS	3.52 (2.19)	6.10 (3.79)	10.54 (6.55)			
D7R XR (US)	2EN	95-01	171 (230)	27 776 (61,236)	2.0 (6'6")	6.04 (19'9")	PS/DS	3.5 (2.3)	6.4 (4.0)	10.8 (6.8)			
D7R XR (US)	5MR	97-02	171 (230)	27 776 (61,236)	2.0 (6'6")	6.04 (19'9")	PS/DS	3.5 (2.3)	6.4 (4.0)	10.8 (6.8)			
D7R SII XR (JAPAN)	BPT	03-12	179/240	27 002 (59,540)	1.98 (6'6")**	3.05 (10'0")†	PS	3.52 (2.19)	6.10 (3.79)	10.54 (6.55)			
D7R SII XR (US)	AGN	00-10	179/240	27 002 (59,540)	1.98 (6'6")**	3.05 (10'0")†	PS	3.52 (2.19)	6.10 (3.79)	10.54 (6.55)			
D7H LGP (US)	80Z*	85-90	215/—	25 237 (55,638)	2.235 (7'4")	4.619 (15'2")	PS	3.371 (11'1")	6.8 (4.2)	11.9 (7.4)			

\*D7H models prior to Series II. Product identification number prefix still in use for current product.

\*\*D7R SII STD, XR and LGP machine width is for without trunnion.

†D7R SII STD, XR and LGP machine height is over EROPS, length is for basic machine.

NOTE: Power Shift models show speeds only, not drawbar pull.

NOTE: Track-Type Tractor weights do not include blades until 1967.

## Track-Type Tractors (cont'd)

Model	Product Ident. No. Prefix	Years Built	Horse-power FW/ Drawbar	Approx. Machine Weight kg (lb)	Gauge m (ft) and Width m (ft)	Length m (ft) and Height m (ft)	Transmission	Rated Drawbar Pull — kg (lb) and Forward Speed — km/h (mph)						Remarks	
								1st	2nd	3rd	4th	5th	6th		
D7R LGP	4SR	96-02	179 (240)	29 500 (65,036)	2.24 (7'4")	5.8 (19'0")	PS/FTC	3.5 (2.3)	6.4 (4.0)	10.8 (6.8)					
D7H LGP (US)	4FG*	87-90	230/—	25 894 (57,086)	2.235 (7'4")	4.624 (15'2")	PS/DS								
D7R LGP (US)	3DN	95-01	179 (240)	30 605 (67,472)	2.24 (7'4")	5.8 (19'0")	PS/DS	3.7 (2.3)	6.4 (4.0)	11.1 (6.9)					
D7R LGP (US)	9HM	95-01	179 (240)	29 500 (65,036)	2.24 (7'4")	5.8 (19'0")	PS/FTC	3.5 (2.3)	6.4 (4.0)	10.8 (6.8)					
D7E	MDB	10-11	175 (235)	25 700 (56,669)	1.98 (6'6")	4.88 (16'0")	ED**								
D7R SII LGP	BNX	01-12	179/240	27 626 (60,916)	2.24 (7'4")†	3.16 (10'5")††	PS	3.52 (2.19)	6.10 (3.79)	10.54 (6.55)					
D7R SII LGP	ABJ	00-10	179/240	27 626 (60,916)	2.24 (7'4")†	3.16 (10'5")††	PS	3.52 (2.19)	6.10 (3.79)	10.54 (6.55)					
D7E LGP	SCG	10-11	175 (235)	28 170 (62,115)	2.29 (7'6")	4.88 (16'0")	ED**								
D8	1H	35-41	110/95	14 790 (32,600)	1.98 (6'6")	4.64 (15'3")	•	9680 (21,350)	6870 (15,150)	5720 (12,610)	4800 (10,590)	3860 (8520)	2740 (6050)		
D8	8R	41-45	131/113	15 490 (34,160)	2.64 (8'8")	2.28 (7'6")	••	2.7 (1.7)	3.8 (2.4)	4.5 (2.8)	5.1 (3.2)	6.3 (3.9)	8.5 (5.3)	RD-8 with 192 cm (78") gauge	
D8	2U	45-53	148/130	16 470 (36,310)	1.98 (6'6")	4.85 (15'10")	DD	13 060 (29,900)	9750 (21,700)	7940 (17,500)	6800 (15,000)	5620 (12,400)	3990 (8800)	Horsepower Increase	
D8	13A	53-55	185/150	16 866 (37,150)	2.64 (8'8")	2.18 (7'2")	DD	2.5 (1.6)	3.7 (2.3)	4.6 (2.9)	5.9 (3.7)	7.7 (4.8)		HP increase, DD transmission	
D8D, G	15A	55-57	191/155	16 310 (35,925)	1.98 (6'6")	5.23 (17'2")	TC	20 358 (44,840)	12 939 (28,500)	8926 (19,660)	6955 (15,320)	4935 (10,870)			
D8E, F	14A	55-57	191/155 Belt	17 734 (39,060)	2.64 (8'8")	2.26 (7'6")	DD	3.1 (1.9)	4.3 (2.7)	5.6 (3.5)	7.2 (4.5)	9.3 (5.8)			
D8H	35A	59-61	235	20 924 (46,032)	2.13 (7'0")	5.20 (17'1")	TC	5.8 (3.6)	8.5 (5.3)	11.9 (7.4)					
					2.87 (9'1")	2.39 (7'10")		20 439 (45,020)	16 135 (35,540)	10 964 (24,150)	7373 (16,240)	4953 (10,910)			
								2.4 (1.5)	3.1 (1.9)	4.5 (2.8)	6.1 (3.8)	8.3 (5.2)			
								5.6 (3.5)	8.2 (5.1)	12.2 (7.6)					

\*D7H models prior to Series II. Product identification number prefix still in use for current product.

\*\*Electric drive machines do not have transmission gears.

†D7R SII STD, XR and LGP machine width is for without trunnion.

††D7R SII STD, XR and LGP machine height is over EROPS, length is for basic machine.

• Power transmitted through dry tape flywheel clutch to selective type hinge speed gear set.

•• Power transmitted through flexible and over center engagement, dry flywheel clutch with metallic friction surfaces. Selective type change speed gear set.

NOTE: Power Shift models show speeds only, not drawbar pull.

NOTE: Track-Type Tractor weights do not include blades until 1967.



## Track-Type Tractors (cont'd)

Model	Product Ident. No. Prefix	Years Built	Horsepower FW/ Drawbar	Approx. Machine Weight kg (lb)	Gauge m (ft) and Width m (ft)	Length m (ft) and Height m (ft)	Transmission	Rated Drawbar Pull — kg (lb) and Forward Speed — km/h (mph)						Remarks
								1st	2nd	3rd	4th	5th	6th	
D8H	36A	58-66	235/185	21 400 (47,180)	2.13 (7'0")	5.20 (17'1")	DD	19 958 (44,400)	15 648 (34,500)	10 931 (24,100)	8051 (17,750)	5869 (13,000)	3832 (8450)	
D8H	46A	58-74	270	21 863 (48,210)	2.87 (9'1")	2.39 (7'10")	PS	2.4 (1.5)	3.0 (1.9)	4.3 (2.7)	5.6 (3.5)	7.4 (4.6)	10.1 (6.3)	
D8K	76V	74-82	300	31 980 (69,300)*	2.13 (7'0")	5.26 (17'3")	DD	25 400 (56,000)	18 930 (41,740)	12 990 (28,640)	9370 (20,650)	6610 (14,580)	4090 (9010)	Turbocharged, Sealed and Lubricated Track
D8K	77V	74-82	300	31 430 (70,500)†	2.13 (7'0")	5.26 (17'3")	PS	2.7 (1.7)	3.5 (2.2)	4.8 (3.0)	6.3 (3.9)	8.2 (5.1)	11.3 (7.0)	Turbocharged, Sealed and Lubricated Track
D8L	53Y 7JC 7YB	82-86 84-90 85-92	335	37 305 (82,243)	2.2 (7'3")	4.95 (16'2")	PS	3.9 (2.4)	6.8 (4.2)	11.9 (7.4)				
D8L SA	4FB	84-87	400/325	36 650 (80,820)	2.54 (8'4")	3.11 (10'3")	DD	31 679 (69,840)	23 115 (50,960)	17 196 (37,910)	12 388 (27,310)	9154 (20,180)	6428 (14,170)	
D8N	9TC 5TJ	87-92 92-95	285	37 462 (82,590)	2.08 (6'10")	4.95 (16'3")	PS	3.05 (10'0")	3.43 (11'3")	10.8 (6.7)				
D8R Series II (US)	6YZ	00-04	310	37 830 (83,400)	2.08 (6'10")	6.91 (22'8")	PS	3.05 (10'0")	3.51 (11'6")	10.6 (6.6)				
D8R Series II (BRAZIL)	AKA	2000	231/310	37 830 (83,400)	2.08 (6'10")	6.91 (22'8")	PS	3.05 (10'0")	3.51 (11'6")	10.6 (6.6)				
D8T**	MLN-FTC	11-14	271	39 420 (86,900)	2.08 (6'10")	4.55 (14'7")	PS/DS	67 414 (148,621)	37 025 (81,628)	20 139 (44,399)				
D8T LGP**	MLN-FTC	11-14	271	37 420 (82,496)	3.06 (10'1")	3.5 (11'6")	PS/DS	3.4 (2.1)	6.1 (3.7)	10.6 (6.6)				
					2.33 (7'8")	4.55 (14'7")		67 414 (148,621)	37 025 (81,628)	20 139 (44,399)				
					3.37 (11'1")	3.5 (11'6")		3.4 (2.1)	6.1 (3.8)	10.6 (6.6)				

\*Approximate operating weight. Includes lubricants, coolant, full fuel tank, hydraulic control, 8S Bulldozer, ROPS canopy and operator. All other weights listed in this column are shipping weights.

\*\*Meets Tier 4 Interim/Stage IIIB/Japan 2011 (Tier 4 Interim) equivalent emission standards.

†Power transmitted through dry tape flywheel clutch to selective type hinge speed gear set.

NOTE: Power Shift models show speeds only, not drawbar pull.

NOTE: Track-Type Tractor weights do not include blades until 1967.

Track-Type Tractors (cont'd)

Model	Product Ident. No. Prefix	Years Built	Horse-power FW/ Drawbar	Approx. Machine Weight kg (lb)	Gauge m (ft) and Width m (ft)	Length m (ft) and Height m (ft)	Transmission	Rated Drawbar Pull — kg (lb) and Forward Speed — km/h (mph)								
								1st	2nd	3rd	4th	5th	6th			
								D9D	18A	55-56	286/230	25 772 (56,765)	2.29 (7'6") 3.03 (10'0")	5.46 (17'11") 2.67 (8'9")	DD	27 631 (60,860)
D9D	18A	56-59	320/260	26 125 (57,543)	2.29 (7'6") 3.03 (10'0")	5.46 (17'11") 2.67 (8'9")	DD	28 603 (63,000)	23 835 (52,500)	16 617 (36,600)	12 167 (26,800)	9171 (20,200)	6106 (13,450)			
D9D	19A	55-56	286/230	25 729 (56,670)	2.29 (7'6") 3.03 (10'0")	5.46 (17'11") 2.67 (8'9")	TC				6.6 (4.1)	9.0 (5.6)	12.6 (7.8)			
D9D	19A	56-59	320/260	26 238 (57,990)	2.29 (7'6") 3.03 (10'0")	5.46 (17'11") 2.68 (8'9")	TC				6.6 (4.1)	9.5 (5.9)	13.0 (8.1)			
D9E	50A	59-60	335	27 016 (59,506)	2.29 (7'6") 3.03 (10'0")	5.50 (18'1") 2.70 (8'11")	TC									
D9D	34A	59-61	335	27 167 (59,837)	2.29 (7'6") 3.03 (10'0")	5.50 (18'1") 2.70 (8'11")	PS				4.2 (2.6)	7.2 (4.5)	11.2 (7.0)			
D9E	49A	59-60	335/268	26 957 (59,375)	2.29 (7'6") 3.03 (10'0")	5.50 (18'1") 2.70 (8'11")	DD									
D9G	66A	61-74	385	31 072 (68,500)	2.29 (7'6") 3.10 (10'0")	5.50 (18'1") 2.10 (8'7")	PS				2.7 (1.7)	3.5 (2.2)	4.8 (3.0)	6.4 (4.0)	8.2 (5.1)	11.4 (7.1)
											3.9 (2.4)	6.8 (4.2)	10.5 (6.5)			

NOTE: Power Shift models show speeds only, not drawbar pull.  
 NOTE: Track-Type Tractor weights do not include blades until 1967.

Track-Type Tractors (cont'd)

Model	Product Ident. No. Prefix	Years Built	Horsepower FW/ Drawbar	Approx. Machine Weight kg (lb)	Gauge m (ft) and Width m (ft)	Length m (ft) and Height m (ft)	Transmission	Rated Drawbar Pull — kg (lb) and Forward Speed — km/h (mph)						Remarks
								1st	2nd	3rd	4th	5th	6th	
S × S D9G	29N	69-74	770	86 200* (190,000)	5.8* (19'0")	8.0◄ (25'0")	PS							L.H. of S × S D9G
	30N				7.3** (24'0")	2.8◄◄ (9'2")		3.9 (2.4)	6.8 (4.2)	10.0 (6.2)	R.H. of S × S D9G			
Dual D9G	90J	69-74	770	79 470* (175,200)	2.3* (7'6")	12.9◄ (42'6")	PS							Front of Dual D9G
	91J				3.3** (10'9")	3.1◄◄ (9'11")		3.9 (2.4)	6.8 (4.2)	10.5 (6.5)	Rear of Dual D9G			
S × S D9H	99V	74-77	820	83 400* (183,900)	5.8* (19'0")	9.0◄ (26'1")	PS							L.H. of S × S D9H
	12U				7.3** (24'0")	2.9◄◄ (9'6")		4.0 (2.5)	6.9 (4.3)	10.8 (6.7)	R.H. of S × S D9H			
Dual D9H	97V	74-80	820	81 100* (178,800)	2.3* (7'6")	12.9◄ (42'6")	PS							Front of Dual D9H
	98V				3.3** (10'9")	3.1◄◄ (9'11")		4.0 (2.5)	6.9 (4.3)	10.8 (6.7)	Rear of Dual D9H			
D9H	90V	74-81	410	32 840 (72,400)	2.3* (7'6")	5.6 (18'5")	PS							Standard Model
	D9L				14Y	80-87		460	52 055 (114,656)	3.0 (9'11")	2.7◄◄ (8'10")	4.0 (2.5)	6.9 (4.3)	
D9N	1JD	86-94	370	42 816 (96,196)	2.55 (7'5")	5.17 (16'11.5")	PS							
	6XJ				93-95	2.43 (9'7")		3.91 (12'10")	3.9 (2.4)	6.9 (4.3)	12.1 (7.5)			
D9R (CB) (US)	ACL	00-04	410	49 147 (108,350)	2.25 (7'5")	6.84 (22'5")	PS							
	D9R (DS) (US)				ABK	00-04		410	49 510 (109,150)	3.30 (10'10")	3.99 (13'1")	3.8 (2.4)	6.8 (4.2)	11.9 (7.4)
D9T	RJS	04-11	410	47 900 (105,600)	2.25 (7'5")	6.85 (22'6")	PS							
					D9T	3.31 (10'11")		3.99 (13'1")	3.9 (2.4)	6.8 (4.2)	11.7 (7.3)			

\*Gauge of both tractors combined.

\*\*Width to outside of dozer blade.

\*Approximate weight of both machines plus Bulldozer, hydraulic controls, coolant and 5% fuel. (D10, D11N, D11R includes SS ripper)

NOTE: Power Shift models show speeds only, not drawbar pull.

NOTE: Track-Type Tractor weights do not include blades until 1967.

◄ Length including dozer blade.

◄◄ Overall height excluding stack and canopy.

## Track-Type Tractors (cont'd)

Model	Product Ident. No. Prefix	Years Built	Horsepower FW/ Drawbar	Approx. Machine Weight kg (lb)	Gauge m (ft) and Width m (ft)	Length m (ft) and Height m (ft)	Transmission	Rated Drawbar Pull — kg (lb) and Forward Speed — km/h (mph)						Remarks
								1st	2nd	3rd	4th	5th	6th	
D10	84W	78-86	700	88 245 (194,140)	2.9 (9'6")	5.92 (19'8")	PS							Width 2.2 m (7'0") 2.9 m (9'6") gauge 1.9 × 2.7 m (6'4" × 8'10") gauge Width 3.45 m (11'4")
	76X				3.65 (12'0")	4.63 (15'2")		3.9 (2.4)	6.8 (4.2)	11.6 (7.2)				
D10N	2YD	87-93	520	66 400 (147,405)	2.55 (8'4")	5.89 (18'4")	PS							3412 DITA HEUI™
	3SK	93-96			3.30 (10'10")	4.45 (14'7")		4.0 (2.5)	7.1 (4.4)	12.5 (7.7)				
D10R	3KR	95-02	570	65 764 (144,986)	2.55 (8'4")	7.50 (24'7")	TD 3-Spd PS							C27 ACERT™ DITA MEUI™
	AKT	01-04	580	65 400 (144,200)	3.72 (12'2")	3.27 (10'9")	PS	4.0 (2.5)	7.1 (4.4)	12.5 (7.7)				
D10T	RJG	05-14	580	70 171 (154,700)	2.55 (8'4")	7.42 (24'4")	TD 3-Spd PS							C27 ACERT™ DITA MEUI™
					3.74 (12'3")	3.22 (10'7")		4.0 (2.5)	7.2 (4.5)	12.7 (7.9)				
D11N	74Z	86-93	770	95 900 (211,000)	2.90 (9'6")	6.16 (20'3")	PS							C32 ACERT DITA MEUI
	4HK	93-96		97 450 (214,850)	3.65 (12'0")	4.65 (15'3")		3.9 (2.4)	6.8 (4.4)	11.6 (7.2)				
D11R	8ZR	96-97	770	98 413 (216,963)	2.89 (9'6")	6.16 (20'3")	PS							C32 ACERT DITA MEUI
	9TR	97-99	850	104 590 (230,100)	3.60 (11'10")	4.65 (15'3")		3.9 (2.4)	6.8 (4.4)	11.6 (7.2)				
D11R	7PZ	00-07	850	104 600 (230,100)	2.89 (9'6")	5.21 (17'1")	PS							C32 ACERT DITA MEUI
	9XR	96-99	850	111 590 (246,000)	3.60 (11'10")	4.57 (15'0")		3.9 (2.4)	6.8 (4.2)	11.8 (7.3)				
D11R CD	9XR	96-99	850	111 590 (246,000)	2.89 (9'6")	6.16 (20'3")	PS							C32 ACERT DITA MEUI
	AAF	96-07	850	113 000 (248,600)	3.60 (11'10")	4.65 (15'3")		3.9 (2.4)	6.8 (4.2)	11.8 (7.3)				
D11R CD	AAF	96-07	850	113 000 (248,600)	2.89 (9'6")	5.21 (17'1")	PS							C32 ACERT DITA MEUI
	GEB	07-11	850	104 590 (230,581)	3.81 (12'6")	4.57 (15'0")		3.9 (2.4)	6.8 (4.2)	11.8 (7.3)				
D11T	GEB	07-11	850	104 590 (230,581)	2.89 (9'6")	8.64 (28'4")	TD 3-Spd PS							C32 ACERT DITA MEUI
	TPB	07-11	850	113 000 (249,122)	4.38 (14'4")	3.64 (11'11")		3.9 (2.4)	6.8 (4.2)	11.8 (7.3)				
D11T CD	TPB	07-11	850	113 000 (249,122)	2.89 (9'6")	8.77 (28'9")	TD 3-Spd PS							C32 ACERT DITA MEUI
					4.38 (14'4")	3.64 (11'11")		3.9 (2.4)	6.8 (4.2)	11.8 (7.3)				

◀ Overall height excluding stack and canopy.

NOTE: Power Shift models show speeds only, not drawbar pull.

NOTE: Track-Type Tractor weights do not include blades until 1967.

## Former Models

## Track-Type Tractors

- Manufactured Outside U.S.A.

### TRACK-TYPE TRACTORS MANUFACTURED OUTSIDE U.S.A.

Source	Model	Product Ident. No. Prefix	Years Built	Horsepower Flywheel/ Drawbar	Transmission	Gauge m (ft)
U.K.	D4C	24A	60-64	63/50	DD	1.52 (5'0")
	D4D	88A	64-67	65/52	DD	1.52 (5'0")
	D6C	82A	64-68	120/93	DD	1.88 (6'2")
	D6C	83A	64-68	120/—	PS	1.88 (6'2")
	D6C	46J	71-77	140/—	DD	1.88 (6'2")
	D6C	47J	71-77	140/—	PS	1.88 (6'2")
	D8H	52A	59-61	235/—	PS	2.13 (7'0")
	D8H	22A	59-66	235/185	DD	2.13 (7'0")
	D8H	68A	60-66	235/—	PS	2.13 (7'0")
D8K	66V	74-82	300/—	PS	2.13 (7'0")	
Brazil	D4D	97F	69-78	75/—	DD	1.52 (5'0")
	D4D	74U	71-78	75/—	PS	1.52 (5'0")
	D6C	24U	71-77	120/93	PS	1.88 (6'2")
	D6C	23U	73-77	120/93	DD	1.88 (6'2")
	D6D	74W	77-92	140/—	DD	1.88 (6'2")
	D6D	75W	77-92	140/—	PS	1.88 (6'2")
	D6D	9FK	92-96	140/—	PS	1.88 (6'2")
	D6E	2MJ	92-96	155/—	PS	1.88 (6'2")
	D6D	19B	85-91	140/—	PS	1.88 (6'2")
	D6G	2MJ	89-03	160/—	PS	1.88 (6'2")
	D6G SR	3SR	97-01	160/—	PS	1.88 (6'2")
	D6M XL	5WR	96-02	104/140	PS	1.89 (6'2")
	D6M XL	6LR	96-02	104/140	PS	1.89 (6'2")
	D8L	7JC	84-90	335/—	PS	2.2 (7'3")
	D8L	7YB	85-92	335/—	PS	2.2 (7'3")
	D8N	7TK	93-95	285/—	PS	2.08 (6'10")
	D8R	9EM	95-	305/—		
D8R Series II	AKA	00-04	310	PS	2.08 (6'10")	
D8R Series II	AKA	00-04	310	PS	3.05 (10'0")	
Australia	D4	29A	59-61	63/50	DD	1.12 (3'8")
	D4	30A	59-60	63/50	DD	1.52 (5'0")
	D4C	54A	60-62	63/52	DD	1.12 (3'8")
	D4C	55A	60-62	65/52	DD	1.52 (5'0")
	D4D	85A	63-68	65/52	DD	1.52 (5'0")
	D5	51H	68-68	93/75	DD	1.88 (6'2")
	D5	52H	68-69	93/—	PS	1.88 (6'2")
	D6	31A	58-60	93/75	DD	1.52 (5'0")
	D6	32A	58-60	93/75	DD	1.18 (6'2")
	D6B	56A	60-66	90/73	DD	1.52 (5'0")
	D6B	57A	60-68	90/73	DD	1.88 (6'2")
	D6C	71A	63-68	120/93	DD	1.88 (6'2")
	D6C	73A	63-68	120/—	PS	1.88 (6'2")
	D6C	55J	69-72	125/—	DD	1.88 (6'2")
	D6C	56J	69-72	125/—	PS	1.88 (6'2")
China	D6G Series 2	C6G	06-11	160	PS	1.88 (6'2")
	D6G Series 2 LGP	C6X	08-11	160/—	PS	2.11 (6'11")
	D7G Series 2	C7G	06-11	200	PS	1.98 (6'6")
	D7G Series 2	C7G	04-11	149/200	PS	1.98 (6'6")
Indonesia	D6G Series 2	P6G	06-11	160/—	PS	1.88 (6'2")
	D7G	7MB	83-11	202/—	PS	1.98 (6'6")
	D7G Series 2	7MB	83-12	149/200	PS	1.98 (6'6")
France	D4C	69A	61-63	63/50	DD	1.52 (5'0")
	D4D	86A	63-68	65/52	DD	1.52 (5'0")
	D4D LGP	18J	66-68	65/52	DD	1.79 (5'10")
	D4D	58J	67-68	65/—	PS	1.52 (5'0")

Track-Type Tractors Manufactured Outside U.S.A. (cont'd)

Source	Model	Product Ident. No. Prefix	Years Built	Horsepower Flywheel/ Drawbar	Transmission	Gauge m (ft)
France (cont'd)	D4E	68X	78-86	80/—	DD	1.52 (5'0")
	D4E	69X	78-85	80/—	PS	1.52 (5'0")
	D4E LGP	71X	78-85	80/—	DD	1.77 (5'10")
	D4E LGP	72X	78-86	80/—	PS	1.77 (5'10")
	D5	62J	69-77	105/—	DD	1.88 (6'2")
	D5	63J	69-77	105/—	PS	1.88 (6'2")
	D5 LGP	6R	70-77	105/—	PS	2.06 (6'9")
	D5 LGP	12R	70-77	105/—	DD	2.06 (6'9")
	D5B	43X	77-85	105/—	DD	1.88 (6'2")
	D5B	44X	77-86	105/—	PS	1.88 (6'2")
	D5B LGP	45X	77-86	105/—	DD	2.06 (6'9")
	D5B LGP	46X	77-86	105/—	PS	2.06 (6'9")
	D5B	8MB	84-86	105/—	PS	1.52 (5'0")
	D5H	8RC	85-96	120/—	PS	1.80 (5'11")
	D5H LGP	1DD	86-96	130/—	PS	2.16 (7'1")
	D5H XL	8RJ	86-96	130/—	PS	1.89 (6'2")
	D5H	7NC	85-96	120/—	DD	1.80 (5'11")
	D5H LGP	9HC	85-96	130/—	DD	2.16 (7'1")
	D5M XL	4BR	96-02	82/110	PS	1.77 (5'10")
	D5M XL	6GN	96-02	82/110	PS	1.77 (5'10")
	D5M LGP	3DR	96-02	82/110	PS	2.00 (6'7")
	D5M LGP	3CR	96-02	82/110	PS	2.00 (6'7")
	D6M XL	9ZM	96-02	104/140	PS	1.89 (6'2")
D6M XL	3WN	96-02	104/140	PS	1.89 (6'2")	
D6M LGP	2RN	96-02	104/140	PS	2.16 (7'1")	
D6M LGP	4JN	96-02	104/140	PS	2.16 (7'1")	
Scotland	D6D	19X	78-86	140/—	DD	1.88 (6'2")
	D6D	20X	78-86	140/—	PS	1.88 (6'2")
	D6D	0IY	79-87	125/—	PS	1.88 (6'2")
Glasgow	D6H	7PC	86-87	165/—	PS	1.88 (6'2")
	D6H LGP	8YC	86-87	165/—	PS	2.23 (7'4")
Japan	D3	79U	73-79	62/—	PS	1.42 (4'8")
	D3	82U	73-78	62/—	PS	1.42 (4'8")
	D3 LGP	6N	73-79	62/—	PS	1.65 (5'5")
	D3 LGP	83U	73-79	62/—	PS	1.65 (5'5")
	D3B	23Y	79-87	65/—	PS	1.42 (4'8")
	D3B LGP	24Y	79-87	65/—	PS	1.65 (5'5")
	D3B	27Y	79-87	65/—	PS	1.42 (4'8")
	D3B LGP	28Y	79-87	65/—	PS	1.65 (5'5")
	D3B	3YC	85-87	65/—	DD	1.42 (4'8")
	D3B LGP	5MC	85-87	65/—	DD	1.65 (5'5")
	D3C	5KG	87-90	67/—	PS	1.42 (4'7")
	D3C Series II	7JG/4HJ	90-93	70/—	PS	1.42 (4'7")
	D3C LGP	1PJ	87-90	67/—	PS	1.65 (5'4")
	D3C LGP Series II	8GD/5CJ	90-93	70/—	PS	1.65 (5'4")
	D3G XL	CFC	01-03	70	HYS	1.45 (4'9")
	D3G XL*	JMH	03-07	70	HYS	1.45 (4'9")
	D3G LGP	CFF	01-03	70	HYS	1.68 (5'6")
	D3G LGP*	BYR	03-07	70	HYS	1.68 (5'6")
	D4D LGP	67A	65-68	65/52	DD	1.79 (5'10")
	D4D	91A	65-68	65/52	DD	1.52 (5'0")
	D4E	50X	77-86	80/—	DD	1.52 (5'0")
	D4E	51X	77-86	80/—	PS	1.52 (5'0")
	D4E LGP	52X	77-86	80/—	DD	1.77 (5'10")
D4C	1RJ	87-90	78/—	PS	1.42 (4'7")	
D4C Series II	7KG	90-93	80/—	PS	1.42 (4'7")	

\*Meets Tier 2/Stage II/Japan 2001 (Tier 2) equivalent emission standards.

**Track-Type Tractors Manufactured Outside U.S.A. (cont'd)**

Source	Model	Product Ident. No. Prefix	Years Built	Horsepower Flywheel/ Drawbar	Transmission	Gauge m (ft)
Japan (cont'd)	D4C LGP	2CJ	87-90	78/—	PS	1.65 (5'4")
	D4C LGP Series II	98G	90-93	80/—	PS	1.65 (5'4")
	D4G XL	CFN	01-03	80	HYS	1.50 (4'11")
	D4GXL*	HYD	03-07	80	HYS	1.50 (4'11")
	D4G LGP	FDC	01-03	80	HYS	1.68 (5'6")
	D4G LGP*	TLX	03-07	80	HYS	1.68 (5'6")
	D4H	8PB	85-96	90/95	PS	1.67 (5'5")
	D4H LGP	9DB	85-96	105/—	PS	2.0 (6'7")
	D4H	2AC	85-92	90/95	DD	1.67 (5'5")
	D4H LGP	3AC	85-90	90/95	DD	2.0 (6'7")
	D4H XL	8PJ	92-96	105/—	PS	1.77 (5'10")
	D4H LGP	9GJ	92-96	105/—	PS	2.0 (6'7")
	D4H LGP	4NK	92-93	105/—	DD	2.0 (6'7")
	D5	37J	67-68	93/75	DD	1.88 (6'2")
	D5 LGP	98A	67-68	93/75	DD	2.06 (6'9")
	D5	67J	68-77	105/—	DD	1.88 (6'2")
	D5	97J	71-76	105/—	PS	1.88 (6'2")
	D5 LGP	68J	68-77	105/—	DD	2.06 (6'9")
	D5B	47X	77-86	105/—	DD	1.88 (6'2")
	D5B	48X	77-86	105/—	PS	1.88 (6'2")
	D5B LGP	49X	77-86	105/—	DD	2.06 (6'9")
	D5C	6PJ	91-93	90/—	PS	1.54 (5'1")
	D5C LGP	3MK	91-93	90/—	PS	1.72 (5'8")
	D5G XL	FDH	01-03	90	HYS	1.55 (5'1")
	D5GXL*	WGB	03-07	90	HYS	1.55 (5'1")
	D5G LGP	FDW	01-03	90	HYS	1.73 (5'8")
	D5G LGP*	RKG	03-07	90	HYS	1.73 (5'8")
	D5H	3MD	86-96	120/—	PS	1.80 (5'11")
	D5H LGP	4KD	86-96	130/—	PS	2.16 (7'1")
	D5H	1YD	86-96	120/—	DD	1.80 (5'11")
	D5H LGP	2SD	86-96	130/—	DD	2.16 (7'1")
	D5M XL	4JS	96-	82/110	PS	1.77 (5'10")
	D5M XL	5ES	96-02	82/110	PS	1.77 (5'10")
	D5M LGP	5FS	96-	82/110	PS	2.00 (6'7")
	D5M LGP	6AS	96-02	82/110	PS	2.00 (6'7")
	D5M LGP	7LR	97-02	78/105	DDPS	2.00 (6'7")
	D6B	37H	66-67	93/75	DD	1.88 (6'2")
	D6B LGP	38H	66-67	93/75	DD	2.06 (6'9")
	D6C	41A	66-68	120/93	DD	1.88 (6'2")
	D6C	96A	66-68	120/93	PS	1.88 (6'2")
	D6C	26K	68-77	125/—	DD	1.88 (6'2")
	D6C	69C	68-77	125/—	PS	1.88 (6'2")
	D6C LGP	90B	71-77	140/—	DD	2.11 (6'11")
	D6D LGP LS	6HC	86-96	160/—	DD	1.88 (6'2")
	D6D	31X	86-98	140/—	PS	1.88 (6'2")
	D6D	30X	85-96	140/—	DD	1.88 (6'2")
	D6D PTNR	5YB	88-96	160/—	PS	1.88 (6'2")
	D6G	BWJ	02-07	160/—	PS	1.88 (6'2")
	D6M XL	2YS	96-	104/140	PS	1.89 (6'2")
	D6M XL	4HS	96-02	104/140	PS	1.89 (6'2")
	D6M LGP	4GS	96-	104/140	PS	2.16 (7'1")
	D6M LGP	5NR	96-02	104/140	PS	2.16 (7'1")

\*Meets Tier 2/Stage II/Japan 2001 (Tier 2) equivalent emission standards.

Track-Type Tractors Manufactured Outside U.S.A. (cont'd)

Source	Model	Product Ident. No. Prefix	Years Built	Horsepower Flywheel/ Drawbar	Transmission	Gauge m (ft)
Japan (cont'd)	D6R	S6X	10-	175	PS	1.88 (74")
	D6R XL	S6T	10-	195	PS	1.88 (74")
	D6R LGP	S6Y	10-	195	PS	2.286 (90")
	D6R SIII	JEK	06-10	138/185	PS	1.88 (6'2")
	D6R SIII XL	EXL	06-12	149/200	PS	1.88 (6'2")
	D6R SIII XW	EXW	07-09	149/200	PS	2.03 (6'8")
	D6R SIII LGP	LGP	06-12	149/200	PS	2.29 (7'6")
	D7G	35N	80-91	202/—	PS	1.98 (6'6")
	D7G LGP	44W	76-87	202/—	PS	1.98 (6'6")
	D7G LGP	45W	75-86	202/—	DD	1.98 (6'6")
	D7G	64V	75-88	202/—	DD	1.98 (6'6")
	D7G	65V	75-07	202/—	PS	1.98 (6'6")
	D7G	65V	75-07	149/200	PS	1.98 (6'6")
	D7H	25B	85-92	215/—	DD	1.98 (6'6")
	D7H LGP	82Z	85-92	215/—	DD	2.54 (8'5") 3.15 (10'4")
	D7R	DSH	12-	240	PS	1.98 (78")
	D7R XR	DJR	12-	240	PS	1.98 (78")
	D7R LGP	DLN	12-	240	PS	2.235 (88")
	D7R SII	BRM	02-12	179/240	PS	1.98 (6'6")
	D7R SII XR	BPT	03-12	179/240	PS	1.98 (6'6")
D7R SII LGP	BNX	01-12	179/240	PS	2.24 (7'4")	





AGRICULTURAL TRACTORS

Model	Product Ident. No. Prefix	Years Built	Horse-power FW/ Drawbar	Approx. Machine Weight kg (lb)	Height m (ft) Gauge m (ft)	Drawbar Pull kg (lb)* and Forward Speed km/h (mph)							
						1st	2nd	3rd	4th	5th	6th	7th	8th
						Challenger 35	8DN	94-98	175/150	9838 - 12 133 (21,690 - 26,750)	3.05 (10'0")	8604 (18,968)	8499 (18,737)
Challenger 35	8RD	99-01	175/150	9838 - 12 133 (21,690 - 26,750)	3.05 (10'0")	8604 (18,968)	8499 (18,737)	8314 (18,329)	7851 (17,307)	7161 (15,787)	6694 (14,757)	5949 (13,116)	5147 (11,348)
Challenger 35	ADK	99-01	175/150	9838 - 12 133 (21,690 - 26,750)	3.05 (10'0")	8604 (18,968)	8499 (18,737)	8314 (18,329)	7851 (17,307)	7161 (15,787)	6694 (14,757)	5949 (13,116)	5147 (11,348)
Challenger MT735		01-02	235/185	9838 - 10 977 - 20 400 (24,200 - 45,000)	3.05 (10'0")	12 680 (27,900)	12 680 (27,900)	12 680 (27,900)	10 890 (23,950)	9130 (20,090)	8105 (17,830)	7187 (15,810)	6388 (14,050)
Challenger 45	1DR	94-98	200/170	9838 - 12 133 (21,690 - 26,750)	3.05 (10'0")	8675 (19,125)	8675 (19,125)	8675 (19,125)	8255 (18,199)	7710 (16,997)	7318 (16,134)	6757 (14,897)	5891 (12,987)
Challenger 45	ABF	99-01	200/170	9838 - 12 133 (21,690 - 26,750)	3.05 (10'0")	8675 (19,125)	8675 (19,125)	8675 (19,125)	8255 (18,199)	7710 (16,997)	7318 (16,134)	6757 (14,897)	5891 (12,987)
Challenger 45	3BK	99-01	200/170	9838 - 12 133 (21,690 - 26,750)	3.05 (10'0")	8675 (19,125)	8675 (19,125)	8675 (19,125)	8255 (18,199)	7710 (16,997)	7318 (16,134)	6757 (14,897)	5891 (12,987)
Challenger MT745		01-02	255/205	9838 - 10 977 - 20 400 (24,200 - 45,000)	3.05 (10'0")	12 680 (27,900)	12 680 (27,900)	12 680 (27,900)	11 828 (26,020)	9920 (21,820)	8806 (19,370)	7808 (17,180)	6941 (15,270)
Challenger 55	7DM	96-98	225/191	9838 - 12 133 (21,690 - 26,750)	3.05 (10'0")	8675 (19,125)	8675 (19,125)	8675 (19,125)	8255 (18,200)	7802 (17,200)	7188 (15,848)	6593 (14,535)	
Challenger 55	AEN	99-01	225/191	9838 - 12 133 (21,690 - 26,750)	3.05 (10'0")	8675 (19,125)	8675 (19,125)	8675 (19,125)	8255 (18,200)	7802 (17,200)	7188 (15,848)	6593 (14,535)	
Challenger 55	6NN	99-01	225/191	9838 - 12 133 (21,690 - 26,750)	3.05 (10'0")	8675 (19,125)	8675 (19,125)	8675 (19,125)	8255 (18,200)	7802 (17,200)	7188 (15,848)	6593 (14,535)	
Challenger MT755		01-02	290/235	10 097 - 20 400 (24,200 - 45,000)	3.37 (11'1")	12 682 (27,900)	12 682 (27,900)	12 682 (27,900)	12 682 (27,900)	11 302 (24,865)	10 032 (22,070)	8896 (19,570)	7908 (17,397)
Challenger MT765		01-02	306/255	10 977 - 20 411 (24,200 - 45,000)	3.37 (11'1")	12 682 (27,900)	12 682 (27,900)	12 682 (27,900)	12 682 (27,900)	11 894 (26,168)	10 558 (23,228)	9362 (20,597)	8322 (18,308)

\*Base gauge (no spacers) of 1.47 m (60") available on 8DN1-849, 1DR1-1699, 7DM1-849. Base gauges (no spacers) of 1.47 m (60") and 2.03 m (80") available on 8DN850-Up, 1DR1700-Up, and 7DM850-Up.

## Agricultural Tractors (cont'd)

Model	Product Ident. No. Prefix	Years Built	Horse-power FW/ Drawbar	Approx. Machine Weight kg (lb)	Height m (ft) Gauge m (ft)	Drawbar Pull kg (lb)* and Forward Speed km/h (mph)							
						9th	10th	11th	12th	13th	14th	15th	16th
Challenger 35	8DN	94-98	175/150	9838 -	3.05	4436	3740	3171	2601	2154	1771	1449	1196
				12 133	(10'0")	(9779)	(8244)	(6991)	(5735)	(4749)	(3904)	(3194)	(2637)
Challenger 35	8RD	99-01	175/150	9838 -	3.05	4436	3740	3171	2601	2154	1771	1449	1196
				12 133	(10'0")	(9779)	(8244)	(6991)	(5735)	(4749)	(3904)	(3194)	(2637)
Challenger 35	ADK	99-01	175/150	9838 -	3.05	4436	3740	3171	2601	2154	1771	1449	1196
				12 133	(10'0")	(9779)	(8244)	(6991)	(5735)	(4749)	(3904)	(3194)	(2637)
Challenger MT735		01-02	235/185	9838 -	3.05	4436	3740	3171	2601	2154	1771	1449	1196
				12 133	(10'0")	(9779)	(8244)	(6991)	(5735)	(4749)	(3904)	(3194)	(2637)
Challenger 45	1DR	94-98	200/170	9838 -	3.05	5063	4170	3547	2920	2427	2003	1646	1365
				12 133	(10'0")	(11,162)	(9193)	(7821)	(6438)	(5351)	(4416)	(3629)	(3010)
Challenger 45	ABF	99-01	200/170	9838 -	3.05	5063	4170	3547	2920	2427	2003	1646	1365
				12 133	(10'0")	(11,162)	(9193)	(7821)	(6438)	(5351)	(4416)	(3629)	(3010)
Challenger 45	3BK	99-01	200/170	9838 -	3.05	5063	4170	3547	2920	2427	2003	1646	1365
				12 133	(10'0")	(11,162)	(9193)	(7821)	(6438)	(5351)	(4416)	(3629)	(3010)
Challenger MT745		01-02	255/205	9838 -	3.05	5063	4170	3547	2920	2427	2003	1646	1365
				12 133	(10'0")	(11,162)	(9193)	(7821)	(6438)	(5351)	(4416)	(3629)	(3010)
Challenger 55	7DM	96-98	225/191	9838 -	3.05	5663	4676	3990	3295	2747	2275	1876	1562
				12 133	(10'0")	(12,484)	(10,310)	(8796)	(7264)	(6056)	(5015)	(4135)	(3443)
Challenger 55	AEN	99-01	225/191	9838 -	3.05	5663	4676	3990	3295	2747	2275	1876	1562
				12 133	(10'0")	(12,484)	(10,310)	(8796)	(7264)	(6056)	(5015)	(4135)	(3443)
Challenger 55	6NN	99-01	225/191	9838 -	3.05	5663	4676	3990	3295	2747	2275	1876	1562
				12 133	(10'0")	(12,484)	(10,310)	(8796)	(7264)	(6056)	(5015)	(4135)	(3443)
Challenger MT755		01-02	290/235	9838 -	3.05	5663	4676	3990	3295	2747	2275	1876	1562
				12 133	(10'0")	(12,484)	(10,310)	(8796)	(7264)	(6056)	(5015)	(4135)	(3443)
Challenger MT765		01-02	306/255	9838 -	3.05	5663	4676	3990	3295	2747	2275	1876	1562
				12 133	(10'0")	(12,484)	(10,310)	(8796)	(7264)	(6056)	(5015)	(4135)	(3443)
Challenger MT755		01-02	290/235	10 097 -	3.37	7029	6248	5541	4919	4133	3253	2570	2024
				20 400	(11'1")	(15,464)	(13,745)	(12,190)	(10,821)	(9093)	(7157)	(5655)	(4454)
Challenger MT765		01-02	306/255	10 977 -	3.37	7397	6575	5831	5176	4350	3424	2705	2130
				20 411	(11'1")	(16,274)	(14,466)	(12,829)	(11,388)	(9569)	(7533)	(5951)	(4687)
Challenger MT765		01-02	306/255	24 200 -		10.4	11.7	13.2	14.9	17.7	22.5	28.5	39.7
				45,000)		(6.5)	(7.3)	(8.2)	(9.3)	(11.0)	(14.0)	(17.7)	(24.6)

\*Base gauge (no spacers) of 1.47 m (60") available on 8DN1-849, 1DR1-1699, 7DM1-849. Base gauges (no spacers) of 1.47 m (60") and 2.03 m (80") available on 8DN850-Up, 1DR1700-Up, and 7DM850-Up.

**Agricultural Tractors (cont'd)**

Model	Product Ident. No. Prefix	Years Built	Horse-power FW/ Drawbar	Approx. Machine Weight kg (lb)	Height m (ft) Gauge m (ft)	Drawbar Pull kg (lb)* and Forward Speed km/h (mph)									
						1st	2nd	3rd	4th	5th	6th	7th	8th	9th	10th
Challenger 65	7YC	86-90	270/200	14 061	3.24	14 825	10 393	8880	7701	6656	5708	4950	4245	2858	1725
				(31,000)	(10'8")	(32,684)	(22,912)	(19,577)	(16,978)	(14,674)	(12,583)	(10,912)	(9358)	(6300)	(3803)
					2.15	4.2	6.4	7.5	8.6	9.9	11.3	13.0	14.9	19.3	29.3
Challenger 65B	7YC	91-92	285/225	14 060	3.24	14 893	11 074	9492	8252	7138	6109	5294	4545	3057	1851
				(31,000)	(10'8")	(32,914)	(24,413)	(20,926)	(18,193)	(15,737)	(13,467)	(11,672)	(10,019)	(6740)	(4080)
					2.15	4.2	6.4	7.5	8.6	9.9	11.3	13.0	14.9	19.3	29.3
Challenger 65C	2ZJ	93-95	285/225	14 330	3.24	12 587	9574	8186	7156	6147	5230	4497	3855	2701	1637
				(31,530)	(10'8")	(27,750)	(21,106)	(18,046)	(15,775)	(13,551)	(11,530)	(9914)	(8498)	(5955)	(3610)
					2.29	4.2	6.4	7.5	8.6	9.9	11.3	13.0	14.9	19.3	29.1
Challenger 65D	2ZJ	95-97	300	14 909	3.24	12 689	10 706	9161	7934	6837	5843	5005	4256	3119	2030
				(32,875)	(10'8")	(27,975)	(23,603)	(20,197)	(17,492)	(15,072)	(12,881)	(11,034)	(9382)	(6875)	(4475)
					2.29	4.2	6.4	7.5	8.6	9.9	11.3	13.0	14.9	19.3	29.1
Challenger 65E	97-02	310/277		15 186	3.4	15 098	10 808	9265	8096	6964	6017	5247	4469	3396	2279
				(33,480)	(11'2")	(33,284)	(23,827)	(20,425)	(17,849)	(15,352)	(13,265)	(11,567)	(9853)	(7488)	(5025)
					4.3	6.4	7.6	8.7	10.0	11.3	12.9	14.8	19.3	29.0	
Challenger 70C	2YL	93-95	1st Gear 215/154 2nd & up 285/225	16 201	3.24	12 621	9574	8186	7156	6147	5230	4497	3855	2701	1637
				(35,685)	(10'8")	(27,825)	(21,106)	(18,046)	(15,775)	(13,551)	(11,530)	(9914)	(8498)	(5955)	(3610)
					2.29	4.2	6.4	7.5	8.6	9.9	11.3	13.0	14.9	19.3	21.1
Challenger 75	4CJ	91-92	325/256	14 060	3.24	15 391	12 371	10 753	9382	8073	6923	6017	5162	3588	2181
				(31,000)	(10'8")	(33,931)	(27,273)	(23,706)	(20,684)	(17,797)	(15,263)	(13,264)	(11,379)	(7910)	(4830)
					2.15	4.2	6.4	7.5	8.6	9.9	11.3	13.0	14.9	19.3	29.3
Challenger 75C	4KK	92-97	325/268	15 158	3.24	12 689	10 761	9329	8106	6932	5944	5095	4380	3075	1878
				(33,419)	(10'8")	(27,975)	(23,724)	(20,567)	(17,871)	(15,282)	(13,105)	(11,232)	(9657)	(6780)	(4140)
					2.29	4.2	6.4	7.5	8.6	9.9	11.3	13.0	14.9	19.3	29.1
Challenger 75D	5AR	96-97	330	14 878	3.24	12 884	12 562	10 919	9526	8197	7030	6109	5241	3643	2225
				(32,800)	(10'8")	(28,406)	(27,693)	(24,071)	(21,003)	(18,071)	(15,498)	(13,468)	(11,554)	(8031)	(4904)
					2.29	4.2	6.4	7.5	8.6	9.9	11.3	13.0	14.9	19.3	29.1
Challenger 75E	97-02	340/301		15 186	3.4	15 174	11 696	9402	8155	7015	6412	5543	4798	3502	2447
				(33,480)	(11'2")	(33,452)	(25,785)	(20,728)	(17,979)	(15,466)	(14,135)	(12,221)	(10,578)	(7722)	(5395)
					2.29	4.5	6.4	7.9	9.0	10.3	11.3	12.9	14.8	20.1	29.0
Challenger 85C	9TK	92-97	1-2 Gears 325/216 3-10 Gears 355/272	15 186	3.24	12 689	11 596	9544	8302	7089	6406	5490	4720	3146	2024
				(33,480)	(10'8")	(27,975)	(25,565)	(21,042)	(18,304)	(15,629)	(14,122)	(12,104)	(10,406)	(6935)	(4461)
					2.29	4.5	6.4	7.9	9.0	10.5	11.3	13.0	14.9	20.3	29.1
Challenger 85D	4GR	96-97	Gears 1-2 330 3-5 360 6-10 370	15 286	3.24	15 529	10 684	9599	8247	7175	6590	5705	4887	3825	2461
				(33,700)	(10'8")	(34,234)	(23,553)	(21,162)	(18,181)	(15,819)	(14,528)	(12,578)	(10,774)	(8432)	(5425)
					2.29	4.0	6.25	7.75	8.9	10.2	11.2	12.8	14.7	20.3	29.1
Challenger 85E	97-02	375/339		15 413	3.4	15 454	11 576	10 566	9177	7997	7268	6323	5417	3954	2763
				(33,980)	(11'2")	(34,070)	(25,520)	(23,294)	(20,232)	(17,629)	(16,022)	(13,940)	(11,942)	(8718)	(6090)
					2.29	4.5	6.4	7.9	9.0	10.3	11.3	12.9	14.8	20.1	29.0
					(7'6")	(2.8)	(4.0)	(4.9)	(5.6)	(6.4)	(7.0)	(8.0)	(9.2)	(12.5)	(18.0)

\*Drawbar pull figures for SA and SR models are max. at lug.

NOTE: Drawbar pull figures for the Challenger 65 is at max. power as found in University of Nebraska Tractor Test no. 1268.

This test was performed on concrete. Therefore, usable drawbar pull may be less depending upon soil conditions.

**Agricultural Tractors (cont'd)**

Model	Product Ident. No. Prefix	Years Built	Horse-power FW/ Drawbar	Approx. Machine Weight kg (lb)	Height m (ft) Gauge m (ft)	Drawbar Pull kg (lb)* and Forward Speed km/h (mph)									
						1st	2nd	3rd	4th	5th	6th	7th	8th	9th	10th
						Challenger 95E	97-02	410/375	15 413 (33,980)	3.4 (11'2") 2.29 (7'6")	15 968 (35,202) 4.5 (2.8)	11 506 (25,366) 6.4 (4.0)	10 505 (23,159) 7.9 (4.9)	10 085 (22,234) 9.0 (5.6)	8729 (19,244) 10.3 (6.4)
D3B SA	2PC	85-87	101 6650 (14,670)	2.71 (8'11")	7634 (16,830) 4.1 (2.5)	6226 (13,725) 5.0 (3.1)	5306 (11,700) 5.7 (3.6)	4531 (9990) 6.5 (4.0)	3888 (8573) 7.6 (4.7)						
D3C SA	7JF	87-92	101 7202 (15,846)	2.71 (8'11") 1.52 (5'0")	5552 (12,250) 4.1 (2.5)	4521 (9960) 5.0 (3.1)	3827 (8450) 5.7 (3.6)	3235 (7130) 6.5 (4.0)	2755 (6070) 7.6 (4.7)						
D4D SA	20J	66-68	—/68 6750 (14,900)	2.44 (8'0") 1.52 (5'0")	4590 (10,120) 4.0 (2.5)	3928 (8660) 4.7 (2.9)	3098 (6830) 5.6 (3.5)	2631 (5800) 6.4 (4.0)	2232 (4920) 7.4 (4.6)						
D4D SA	84J	66	—/68 6470 (14,270)	2.67 (8'9") 1.52 (5'0")	4880 (10,750) 4.0 (2.5)	4170 (9200) 4.7 (2.9)	3310 (7300) 5.6 (3.5)	2840 (6260) 6.4 (4.0)	2420 (5330) 7.4 (4.6)						
D4E SA	7PB 2CB	84-89 84-91	97 7600 (16,760)	2.71 (8'11")	5901 (13,102) 3.4 (2.1)	5148 (11,349) 4.6 (2.8)	5831 (12,859) 5.5 (3.5)	5002 (11,027) 6.4 (4.0)	4433 (9773) 8.3 (5.1)						
D4E SA	29X	77-84	—/74 7585 (16,722)	2.72 (8'11") 1.52 (5'0")	5802 (12,791) 4.1 (2.5)	4986 (10,993) 4.7 (2.9)	4007 (8835) 5.8 (3.6)	3814 (8408) 6.6 (4.1)	2896 (6384) 7.5 (4.7)						
D4E SR		84-99	125/— 9400 (20,730)	1.93 (6'4") 1.52 (5'0")	5450 (12,010) 2.7 (1.7)	3744 (8250) 4.2 (2.6)	5068 (11,170) 5.8 (3.6)	4408 (9715) 8.0 (5.0)	3832 (8450) 11.1 (6.9)						
D5 SA	21J	67-67	—/90 9300 (20,400)	2.64 (8'8") 1.88 (6'2")	6620 (14,580) 3.7 (2.3)	5160 (11,360) 4.6 (2.9)	3990 (8740) 5.8 (3.6)	3080 (6790) 7.1 (4.4)	2290 (5030) 8.8 (5.5)						
D5 SA	98J	67-77	—/90 9660 (21,300)	2.95 (9'8") 1.88 (6'2")	6120 (13,500) 3.7 (2.3)	5180 (11,410) 4.6 (2.9)	4110 (9950) 5.8 (3.6)	3640 (7620) 7.1 (4.4)	2950 (6500) 8.8 (5.5)	2250 (4970)					
D5B SA	26X	77-84	—/90	2.77 (9'1") 1.88 (6'2")	6409 (14,130) 4.0 (2.5)	5384 (11,870) 4.7 (2.9)	4323 (9530) 5.6 (3.5)	3688 (8130) 6.6 (4.1)	3180 (7010) 7.4 (4.6)	2486 (5480) 9.0 (5.6)					
D5B SA	22X	77-82	105/— 11 283 (24,875)	2.77 (9'1") 1.52 (5'0")	8060 (17,770) 2.7 (1.7)	5030 (11,100) 4.2 (2.6)	3410 (7520) 5.8 (3.6)	2290 (5060) 8.0 (5.0)	1480 (3260) 11.1 (6.9)						
D5B SA	24X	77-84	105/— 11 619 (25,615)	2.77 (9'1") 1.52 (5'0")	3.5 (2.2) 6.1 (3.8)	6.1 (3.8) 10.1 (6.3)									

\*Drawbar pull figures for SA and SR models are max. at lug.

**NOTE:** Drawbar pull figures for the Challenger 65 is at max. power as found in University of Nebraska Tractor Test no. 1268. This test was performed on concrete. Therefore, usable drawbar pull may be less depending upon soil conditions.

## Agricultural Tractors (cont'd)

Model	Product Ident. No. Prefix	Years Built	Horse-power FW/ Drawbar	Approx. Machine Weight kg (lb)	Height m (ft) Gauge m (ft)	Drawbar Pull kg (lb)* and Forward Speed km/h (mph)											
						1st	2nd	3rd	4th	5th	6th	7th	8th	9th	10th		
D6C SA	17R	70-76	140	13 064 (28,800)	2.67 (8'9")	850 (18,750)	6970 (15,370)	5880 (12,780)	4810 (10,610)	4080 (9000)	3190 (7030)						
D6D SR	7XF	89-91	140	15 200 (33,500)	2.87 (9'5")	4.0 (2.5)	4.8 (3.0)	5.6 (3.5)	6.4 (4.0)	7.4 (4.6)	8.8 (5.5)						
D6D SA 123-161 kW (165-215 HP)	38C	83-91	165	14 500 (32,000)	2.87 (9'5")	14 358 (31,645)	12 429 (27,394)	11 721 (25,833)	7067 (15,576)	6096 (13,436)	4931 (10,868)						
D6D SA 123-179 kW (165-240 HP)	19B	83-91	165	14 500 (32,000)	2.87 (9'5")	2.0 (1.2)	2.9 (1.8)	4.1 (2.5)	6.5 (4.0)	7.4 (4.6)	8.9 (5.5)						
D6E SR	8FJ	91-96	155/216 121/170	14 960 (32,987)	2.03 (6'8")	10 098 (22,243)	8510 (18,744)	9210 (20,287)	7789 (17,156)	6732 (14,828)	5456 (12,017)						
Ag 6 Generation One	05X	77-86	165/240	14 787 (32,600)	3.43 (11'3")	4.5 (2.8)	5.3 (3.3)	6.1 (3.8)	7.1 (4.4)	8.2 (5.1)							
Ag 6 Generation Two	05X	77-86	200/240	14 787 (32,600)	3.48 (11'5")	12 407 (27,353)	10 482 (23,110)	10 667 (23,514)	9091 (19,931)	7830 (17,263)							
D7G SA std. trans.	35N	80-86	250	18 462 (40,700)	3.2 (10'6")	19 101 (42,110)	13 622 (30,030)	11 358 (25,040)	10 015 (22,080)	8627 (19,020)	7584 (16,720)						
D7G SA std. trans. 168-186 kW (225-250 HP)		77-86	250	18 462 (40,700)	3.2 (10'6")	3.5 (2.2)	4.8 (3.0)	5.6 (3.5)	6.4 (4.0)	7.2 (4.5)	8.2 (5.1)						
D8L SA		84-87	400	36 650 (80,820)	3.87 (12'8")	40 252 (88,740)	39 466 (64,960)	22 013 (48,530)	15 953 (35,170)	11 880 (26,190)	8446 (18,620)						
					2.2 (7'3")	2.9 (1.8)	3.9 (2.4)	5.0 (3.1)	6.8 (4.2)	8.9 (5.5)	11.9 (7.4)						

\*Drawbar pull figures for SA and SR models are max. at lug.

**NOTE:** Drawbar pull figures for the Challenger 65 is at max. power as found in University of Nebraska Tractor Test no. 1268.

This test was performed on concrete. Therefore, usable drawbar pull may be less depending upon soil conditions.



MOTOR GRADERS

Model	Product Ident. No. Prefix	Years Built	Horsepower, Rated	Approx. Ship Wt. kg (lb)	Wheel-base m (ft)	Length m (ft)	Width m (ft)	Mold-board Length m (ft)	Turning Radius m (ft)	Controls	Maximum Speed	
											Forward km/h (mph)	Rev. km/h (mph)
212TD	79C	54-57	50	6030 <b>(13,290)</b>	5.03 <b>(16'6")</b>	6.68 <b>(21'11")</b>	2.07 <b>(6'10")</b>	3.05 <b>(10'0")</b>	11.10 <b>(36'5")</b>	Mech.	18.1 <b>(11.2)</b>	4.2 <b>(2.6)</b>
112	3U	47-59	70	8770 <b>(19,330)</b>	5.72 <b>(18'9")</b>	7.59 <b>(24'11")</b>	2.39 <b>(7'10")</b>	3.66 <b>(12'0")</b>	10.87 <b>(35'8")</b>	Mech.	25.7 <b>(16.0)</b>	6.4 <b>(4.0)</b>
112	81C	55-59	75	9435 <b>(20,805)</b>	5.72 <b>(18'9")</b>	7.59 <b>(24'11")</b>	2.39 <b>(7'10")</b>	3.66 <b>(12'0")</b>	10.74 <b>(35'3")</b>	Mech.	25.7 <b>(16.0)</b>	6.4 <b>(4.0)</b>
112E	68E(U.S.) 91G(U.S.)	59-64 64-68	85	9500 <b>(20,900)</b>	5.72 <b>(18'9")</b>	7.62 <b>(25'0")</b>	2.36 <b>(7'9")</b>	3.66 <b>(12'0")</b>	10.74 <b>(35'3")</b>	Mech.	29.3 <b>(18.2)</b>	9.3 <b>(5.8)</b>
112F	82F(U.S.) 46D(U.S.) 74H(U.S.) 89J(U.S.) 80J(AUSTL)	60-64 64-68 67-68 68-74 69-84	100	9800 <b>(21,600)</b>	5.72 <b>(18'9")</b>	7.82 <b>(25'8")</b>	2.36 <b>(7'9")</b>	3.66 <b>(12'0")</b>	10.70 <b>(35'3")</b>	Mech.	29.9 <b>(18.6)</b>	9.7 <b>(6.0)</b>
120	89G(U.S.)	64-67	115	10 480 <b>(23,100)</b>	5.71 <b>(18'9")</b>	7.62 <b>(25'0")</b>	2.36 <b>(7'9")</b>	3.66 <b>(12'0")</b>	10.74 <b>(35'3")</b>	Mech.	32.2 <b>(20.0)</b>	10.3 <b>(6.4)</b>
120	14K(U.S.)	67-69	125	10 600 <b>(23,500)</b>	5.71 <b>(18'9")</b>	7.80 <b>(25'8")</b>	2.36 <b>(7'9")</b>	3.66 <b>(12'0")</b>	10.74 <b>(35'3")</b>	Mech.	32.2 <b>(20.0)</b>	41.5 <b>(25.8)</b>
120	10R(U.S.)	69-74	125	10 700 <b>(23,700)</b>	5.85 <b>(19'2")</b>	7.95 <b>(26'1")</b>	2.36 <b>(7'9")</b>	3.66 <b>(12'0")</b>	10.90 <b>(35'9")</b>	Mech.	32.2 <b>(20.0)</b>	6.6 <b>(4.1)</b>
120	13U(U.S.)	71-74	125	11 000 <b>(24,300)</b>	5.85 <b>(19'2")</b>	7.95 <b>(26'1")</b>	2.36 <b>(7'9")</b>	3.66 <b>(12'0")</b>	10.90 <b>(35'9")</b>	Mech.	32.2 <b>(20.0)</b>	6.6 <b>(4.1)</b>
120B	64U(BRAZ)	72-89	125	12 000 <b>(26,460)</b>	5.85 <b>(19'2")</b>	7.92 <b>(26'0")</b>	2.36 <b>(7'9")</b>	3.66 <b>(12'0")</b>	10.90 <b>(35'9")</b>	Mech.	35.4 <b>(22.0)</b>	23.8 <b>(14.8)</b>
120G	87V(U.S.) 4HD(BRAZ) 11W(AUSTL) 82V(CAN)	73-95 86-95 75-95 74-80	125	12 859 <b>(28,350)</b>	5.69 <b>(18'8")</b>	7.92 <b>(26'0")</b>	2.45 <b>(8'0")</b>	3.66 <b>(12'0")</b>	6.7 <b>(22'0")</b>	Hyd.	40.9 <b>(25.4)</b>	40.9 <b>(25.4)</b>
120H	4MK(U.S.) 6NM(U.S.) 9YR(BRAZ) 2AN(AUSTL) 3GR(S. AFRICA) 124 (AUSTL) ALZ(U.S.) CAF(BRAZ)	95-02 03-05 02-04 03-07	125/140	12 520 <b>(27,600)</b>	5.86 <b>(19'3")</b>	8.26 <b>(27'1")</b>	2.44 <b>(7'11")</b>	3.66 <b>(12'0")</b>	7.2 <b>(23'8")</b>	Hyd.	42.6 <b>(26.5)</b>	33.7 <b>(20.9)</b>
120H	ALZ(U.S.) CAF(BRAZ) 124(AUSTL)	02-03 02-07 03-05	125/140	12 650 <b>(27,880)</b>	5.92 <b>(19'5")</b>	8.31 <b>(27'3")</b>	2.44 <b>(8'0")</b>	3.66 <b>(12'0")</b>	7.3 <b>(23'7")</b>	Hyd.	42.6 <b>(26.5)</b>	33.7 <b>(20.9)</b>
120H STD	6TM(U.S.) 5FM(BRAZ) 9FN(INDO)	96-99 96-09 96-04	125/140	12 466 <b>(27,483)</b>	5.87 <b>(19'3")</b>	8.15 <b>(26'9")</b>	2.44 <b>(8'0")</b>	3.66 <b>(12'0")</b>	7.2 <b>(23'8")</b>	Hyd.	42.6 <b>(26.5)</b>	33.7 <b>(20.9)</b>

## Motor Graders (cont'd)

Model	Product Ident. No. Prefix	Years Built	Horsepower, Rated	Approx. Ship Wt. kg (lb)	Wheel-base m (ft)	Length m (ft)	Width m (ft)	Mold-board Length m (ft)	Turning Radius m (ft)	Controls	Maximum Speed	
											km/h (mph)	km/h (mph)
130G	74V(U.S.)	73-95	135	13 050	5.92	8.30	2.45	3.66	7.3	Hyd.	39.4	39.4
	12W(AUSTL)	75-89		(28,770)	(19'5")	(27'3")	(8'0")	(12'0")	(24'0")		(24.5)	(24.5)
135H	3YK(U.S.)	95-02	135/155	12 950	5.86	8.26	2.44	3.66	7.2	Hyd.	41.9	33.1
	AMX(U.S.)	02-04		(28,550)	(19'3")	(27'1")	(7'11")	(12'0")	(23'8")		(26.0)	(20.6)
135H	CBC(BRAZ)	03-07	135/155	13 080	5.92	8.31	2.44	3.66	7.3	Hyd.	41.9	33.1
	AMX(U.S.)	02-04		(28,840)	(19'5")	(27'3")	(8'0")	(12'0")	(23'7")		(26.1)	(20.6)
12	6M(U.S.)	39-42	66	9440	5.72	7.62	2.39	3.66	10.87	Mech.	24.5	6.1
				(20,820)	(18'9")	(25'0")	(7'10")	(12'0")	(35'8")		(15.2)	(3.8)
12	9K(U.S.)	38-45	70	9590	5.72	7.62	2.39	3.66	10.87	Mech.	24.5	6.1
				(21,140)	(18'9")	(25'0")	(7'10")	(12'0")	(35'8")		(15.2)	(3.8)
12	7T(U.S.)	45-47	75	9750	5.72	7.62	2.39	3.66	10.87	Mech.	24.5	6.1
				(21,500)	(18'9")	(25'0")	(7'10")	(12'0")	(35'8")		(15.2)	(3.8)
12	8T(U.S.)	47-55	100	10 100	5.72	7.62	2.39	3.66	10.87	Mech.	31.1	6.6
	94C(AUSTL)	55-58		(22,375)	(18'9")	(25'0")	(7'10")	(12'0")	(35'8")		(19.3)	(4.1)
12	70D-71D(U.S.)	57-59	115	10 200	5.72	7.62	2.37	3.66	10.87	Mech.	31.1	10.1
	80C(U.S.)	55-67		(22,410)	(18'9")	(25'0")	(7'10")	(12'0")	(35'8")		(19.3)	(6.3)
	38E(AUSTL)	58-60										
12E	99E(U.S.)	59-65	115	11 100	5.72	8.03	2.36	3.66	10.90	Mech.	32.0	22.2
	21F(AUSTL)	60-68		(24,400)	(18'9")	(26'4")	(7'9")	(12'0")	(35'9")		(19.9)	(13.8)
	17K(AUSTL)	68-75										
12F	73G(U.S.)	65-67	115	12 973	6.0	8.20	2.36	3.66	11.40	Hyd.	32.0	22.2
				(28,600)	(19'8")	(26'10")	(7'9")	(12'0")	(37'5")	Mech.	(19.9)	(13.8)
12F	89H(U.S.)	69-73	125	12 973	6.00	8.20	2.36	3.65	11.40	Hyd.	34.3	41.5
	13K(U.S.)	67-73		(28,600)	(19'8")	(26'10")	(7'9")	(12'0")	(37'5")		Mech.	(21.3)
12G	61M(U.S.)	73-95	135	13 554	5.92	8.30	2.45	3.66	7.30	Hyd.	39.4	39.4
	3PL(BRAZ)	93-95		(29,860)	(19'5")	(27'3")	(8'0")	(12'0")	(24'0")		(24.5)	(24.5)
	3WC(AUSTL)	85-95										
12H	4XM(U.S.)	95-02	140	14 247	6.10	8.57	2.44	3.66	7.40	Hyd.	39.7	31.3
	2LR(U.S.)			(31,410)	(20'0")	(28'1")	(7'11")	(12'0")	(24'3")		(24.7)	(19.5)
	8MN(BRAZ)											
	2GS(BRAZ)											
	2WR(AUSTL)											
12H	AMZ(U.S.)	02-07	145/185	14 200	6.09	8.57	2.44	3.66	7.40	Hyd.	44.0	34.7
	CBK(BRAZ)	02-07		(31,320)	(20'0")	(28'1")	(8'0")	(12'0")	(24'3")		(27.4)	(21.6)
	125(AUSTL)	03-05										
12H	AMZ(U.S.)	02-07	140	14 185	6.09	8.45	2.44	3.66	7.4	Hyd.	41.7	32.9
	CBK(BRAZ)	02-07		(31,273)	(20'0")	(27'9")	(8'0")	(12'0")	(24'3")		(25.9)	(20.5)
	125(AUSTL)	03-05										
STD	5ZM(U.S.)	97-98										
	4ER(BRAZ)	96-09										
	XZJ(CHINA)	06-10										

Motor Graders (cont'd)

Model	Product Ident. No. Prefix	Years Built	Horsepower, Rated	Approx. Ship Wt. kg (lb)	Wheel-base m (ft)	Length m (ft)	Width m (ft)	Mold-board Length m (ft)	Turning Radius m (ft)	Controls	Maximum Speed	
											km/h (mph)	km/h (mph)
140	14U(U.S.)	71-74	150	13 109	5.84	7.95	2.44	3.66	10.97	Mech.	38.8	47.0
	11R(U.S.)	70-74		(28,900)	(19'2")	(26'1")	(8'0")	(12'0")	(36'0")		(24.1)	(29.2)
	55F(AUSTL)	71-75										
140B	24R(CAN)	71-74	150	13 620	6.14	8.07	2.39	3.96	11.60	Mech.	37.6	25.6
	61S(BRAZ)	81-87		(30,003)	(20'2")	(26'6")	(7'10")	(13'0")	(38'0")		(23.4)	(15.9)
140G	72V(U.S.)	73-95	150	14 102	5.92	8.33	2.45	3.66	7.30	Hyd.	41.0	41.0
	5MD(BRAZ)	87-95		(31,090)	(19'5")	(27'4")	(8'0")	(12'0")	(24'0")		(25.5)	(25.5)
	13W(AUSTL)	75-95										
140G AWD	81V(CAN)	74-80	150	14 914	5.92	8.33	2.45	3.66	7.30	Hyd.	41.0	41.0
	72V(U.S.)	73-95		(32,880)	(19'5")	(27'4")	(8'0")	(12'0")	(24'0")		(25.5)	(25.5)
140H	2ZK(U.S.)	95-02	165/185	14 724	6.10	8.60	2.46	3.66	7.40	Hyd.	41.1	32.4
	8KM(U.S.)			(32,460)	(20'0")	(28'3")	(8'1")	(12'0")	(24'3")		(25.5)	(20.2)
	9TN(BRAZ)											
	3AS(BRAZ)											
	9ZN(AUSTL)											
	APM(U.S.)	02-07										
140H	CCA(BRAZ)	02-07	165/205	14 677	6.17	8.71	2.46	3.66	7.5	Hyd.	44.0	34.7
	126(AUSTL)	03-05		(32,357)	(20'3")	(28'7")	(8'1")	(12'0")	(24'7")		(27.4)	(21.6)
	APM(U.S.)	02-07										
140H STD	CCA(BRAZ)	02-07	165/185	14 661	6.09	8.60	2.46	3.66	7.4	Hyd.	41.1	32.4
	8JM(U.S.)	96-99		(32,321)	(20'0")	(28'3")	(8'1")	(12'0")	(24'3")		(25.5)	(20.2)
143H	5HM(BRAZ)	96-09	165/185	14 661	6.09	8.60	2.46	3.66	7.4	Hyd.	41.1	32.4
	XZH(CHINA)	05-10		(32,321)	(20'0")	(28'3")	(8'1")	(12'0")	(24'3")		(25.5)	(20.2)
143H	1AL(U.S.)	95-02	165/185	15 023	6.10	8.60	2.46	3.66	7.40	Hyd.	41.1	32.4
	APN(U.S.)	02-07		(33,120)	(20'0")	(28'3")	(8'1")	(12'0")	(24'3")		(25.5)	(20.2)
143H	APN(U.S.)	02-07	165/205	15 270	6.17	8.71	2.55	3.66	7.5	Hyd.	44.0	34.7
				(33,670)	(20'3")	(28'7")	(8'5")	(12'0")	(24'7")		(27.4)	(21.6)
14B	78E(U.S.)	59-59	150	13 300	5.84	8.03	2.44	3.66	10.97	Mech.	34.8	11.3
	64C(U.S.)	59-69		(29,280)	(19'2")	(26'4")	(8'0")	(12'0")	(36'0")		(21.6)	(7.0)
14C	35F(U.S.)	59-61	150	12 973	5.84	8.03	2.44	3.66	10.97	Mech.	34.8	11.3
				(28,600)	(19'2")	(26'4")	(8'0")	(12'0")	(36'0")		(21.6)	(7.0)
14D	96F(U.S.)	61-65	150	13 700	6.15	8.33	2.44	3.96	11.58	Mech.	34.1	23.5
				(30,300)	(20'2")	(27'4")	(8'0")	(13'0")	(38'0")		(21.2)	(14.6)
14E	99G(U.S.)	65-68	150	13 699	6.15	8.33	2.44	3.96	11.58	Hyd.	36.4	24.9
				(30,200)	(20'2")	(27'4")	(8'0")	(13'0")	(38'0")		(22.6)	(15.5)
14E	12K(U.S.)	67-73	150	14 300	6.10	8.30	2.44	3.96	11.60	Hyd.	39.1	47.3
	72G(U.S.)	69-73		(31,600)	(20'2")	(27'4")	(8'0")	(13'0")	(38'0")		(24.3)	(29.4)
14G	96U(U.S.)	73-95	200	20 688	6.45	9.21	2.83	4.27	7.90	Hyd.	43.0	50.1
				(45,610)	(21'2")	(30'3")	(9'3")	(14'0")	(25'11")		(26.8)	(31.1)
14H	7WJ(U.S.)	95-02	215	18 784	6.45	9.21	2.70	4.27	7.90	Hyd.	42.7	47.3
	ASE(U.S.)	02-07		(41,410)	(21'2")	(30'2")	(8'10")	(14'0")	(25'11")		(26.5)	(29.4)
14H	ASE(U.S.)	02-07	220/240	18 809	6.56	9.34	2.82	4.27	8.0	Hyd.	46.1	51.1
				(41,465)	(21'6")	(30'8")	(9'3")	(14'0")	(26'4")		(28.7)	(31.8)
14M	B9J	07-10	259/275	21,676	6.56	9.35	2.8	4.27	7.9	Electro-Hyd	50.4	39.8
	R9J	10-15		(47,787)	(21'6")	(30'8")	(9'2")	(14'0")	(25'11")		(31.3)	(24.7)



## Motor Graders (cont'd)

Model	Product Ident. No. Prefix	Years Built	Horsepower, Rated	Approx. Ship Wt. kg (lb)	Wheel-base m (ft)	Length m (ft)	Width m (ft)	Mold-board Length m (ft)	Turning Radius m (ft)	Controls	Maximum Speed	
											km/h (mph)	km/h (mph)
160H	9EJ(U.S.)	95-02	180/200	15 586	6.10 (20'0")	8.60 (28'3")	2.46 (8'1")	4.27 (14'0")	7.40 (24'3")	Hyd.	40.7	32.1
	6WM(U.S.)			<b>(34,360)</b>							<b>(25.3)</b>	<b>(20.0)</b>
	3GM(BRAZ)											
	2HS(BRAZ)											
	ASD(U.S.)	02-07										
160H	CCP(BRAZ)	02-07	180/220	15 676	6.17 (20'3")	8.71 (28'7")	2.48 (8'2")	4.27 (14'0")	7.5 (24'7")	Hyd.	43.6	34.4
	ASD(U.S.)	02-07		<b>(34,560)</b>							<b>(27.1)</b>	<b>(21.4)</b>
160H	9JM(U.S.)	96-99	180/200	15 524	6.09 (20'0")	8.49 (27'10")	2.46 (8'1")	4.27 (14'0")	7.4 (24'3")	Hyd.	40.7	32.1
STD	2FM(BRAZ)	96-98		<b>(34,225)</b>							<b>(25.3)</b>	<b>(20.0)</b>
	XZK(CHINA)	06-10										
163H	5AK(U.S.)	95-02	180/200	16 538	6.10 (20'0")	8.60 (28'3")	2.46 (8'1")	4.27 (14'0")	7.40 (24'3")	Hyd.	40.7	32.1
	ARL(U.S.)	02-07		<b>(36,460)</b>							<b>(25.3)</b>	<b>(20.0)</b>
163H	ARL(U.S.)	02-07	180/220	16 280	6.17 (20'3")	8.71 (28'7")	2.55 (8'5")	4.27 (14'0")	7.5 (24'7")	Hyd.	43.6 (27.1)	34.4 (21.4)
16	49G(U.S.)	63-73	225	22 499	6.86 (22'6")	9.50 (31'2")	3.00 (9'10")	4.27 (14'0")	13.56 (44'6")	Hyd.	49.7 (30.9)	49.7 (30.9)
16G	93U(U.S.)	73-95	275	27 284	6.96 (22'10")	9.99 (32'8")	3.08 (10'1")	4.88 (16'0")	8.20 (27'0")	Mech.	43.6 (27.1)	43.6 (27.1)
				<b>(60,150)</b>	<b>(27.1)</b>	<b>(27.1)</b>						
16H	6ZJ(U.S.)	95-02	275	24 748	6.96 (22'10")	9.99 (32'9")	2.99 (9'10")	4.88 (16'0")	8.20 (27'0")	Hyd.	44.5 (27.7)	42.3 (26.3)
	ATS(U.S.)	02-07		<b>(54,560)</b>	<b>(27.7)</b>	<b>(26.3)</b>						
16H	ATS(U.S.)	02-07	265/285	24 740	6.96 (22'10")	9.99 (32'9")	3.08 (10'1")	4.88 (16'0")	8.2 (26'11")	Hyd.	48.1 (29.9)	45.7 (28.4)
16M	B9H	07-10	291/326	27 531	6.99 (22'11")	9.96 (32'8")	3.10 (10'2")	4.88 (16'0")	8.9 (29'3")	Electro-Hyd	51.7 (32.1)	40.8 (25.3)
	R9H	10-15		<b>(60,695)</b>	<b>(32.1)</b>	<b>(25.3)</b>						
24H	7KK(U.S.)	96-07	500	61 955	10.23 (33'7")	14.16 (46'6")	4.23 (13'10")	7.3 (24'0")	12.0 (39'11")	Hyd.	37.7 (23.4)	36.1 (22.4)
				<b>(136,611)</b>								



**SKID STEER LOADERS**

Model	Product Ident. No. Prefix	Years Built	Approx. Machine		Length to Coupler mm (in)	Width over Tires mm (in)**	Height to Top of Cab mm (in)	Top Travel		Rated Operating Capacity at 50% kg (lb)	Rated Operating Capacity at 50% with counter-weight kg (lb)
			Weight kg (lb)	Net Power kW (hp)				Speed km/h (mph)	Engine Model		
216	4NZ	99-03	2490 (5490)	36 (48)	2519 (99)	1525 (60)	1950 (77)	3024C	11.5 (7.0)	635 (1400)	680 (1500)
216B	RLL	04-07	2589 (5709)	37 (49)	2519 (99)	1525 (60)	1950 (77)	3024C	12.7 (7.9)	635 (1400)	680 (1500)
216B2	RLL	07-10	3212 (7082)	35 (47)	2519 (99)	1525 (60)	1950 (77)	C2.2	12.7 (7.9)	635 (1400)	680 (1500)
226	5FZ	99-03	2560 (5645)	41 (54)	2519 (99)	1525 (60)	1950 (77)	3034	11.5 (7.0)	680 (1500)	726 (1600)
226B	MJH	04-07	2646 (5834)	42 (57)	2519 (99)	1525 (60)	1950 (77)	3024CT	12.7 (7.9)	680 (1500)	726 (1600)
226B2	MJH	07-10	3283 (7238)	42 (56)	2519 (99)	1525 (60)	1950 (77)	C2.2T	12.7 (7.9)	680 (1500)	726 (1600)
228	6BZ	99-03	2650 (5843)	41 (54)	2519 (99)	1525 (60)	1950 (77)	3034	11.5 (7.0)	680 (1500)	726 (1600)
232	CAB	02-04	3005 (6627)	36 (48)	2776 (110)	1525 (60)	1953 (77)	3024C	11.1 (7.0)	793 (1750)	815 (1795)
232B	SCH	04-07	3021 (6661)	37 (49)	2760 (109)	1525 (60)	1953 (77)	3024C	11.1 (6.9)	793 (1750)	815 (1795)
232B2	SCH	07-10	3588 (7910)	42 (56)	2760 (109)	1525 (60)	1950 (77)	C2.2T	11.1 (6.9)	862 (1900)	883 (1947)
236	4YZ	99-03	3134 (6810)	44 (59)	2800 (110)	1676 (66)	2092 (82)	3034	12.1 (7.5)	793 (1750)	839 (1850)
236B	HEN	04-07	3178 (7007)	52 (70)	2800 (110)	1676 (66)	2092 (82)	3044C DIT	12.2/18.6* (7.6/11.6*)	793 (1750)	815 (1850)
236B2	HEN	07-10	3878 (8550)	53 (71)	2800 (110)	1676 (66)	2092 (82)	C3.4 DIT	12.1 (7.5)	884 (1950)	929 (2050)
236B3	A9H	10-13	3178 (7007)	53 (71)	2800 (110)	1676 (66)	2092 (82)	Cat® C3.4 DIT	18.1 (11.2)	884 (1950)	929 (2050)
242	CMB	02-04	3060 (6748)	41 (54)	2776 (110)	1676 (66)	1986 (78)	3034	11.3 (7.0)	907 (2000)	930 (2045)
242B	BXM	04-07	3085 (6805)	42 (57)	2760 (109)	1676 (66)	1986 (78)	3024CT	12.0 (7.4)	907 (2000)	930 (2045)
242B2	BXM	07-10	3629 (8000)	42 (56)	2760 (109)	1676 (66)	1986 (78)	C2.2T	12.1 (7.5)	952 (2100)	Standard on 242B2
242B3	SRS	10-13	3179 (7008)	53 (71)	2760 (108.7)	1676 (66)	2019 (79)	Cat C3.4 DIT	18.4 (11.4)	975 (2150)	1000 (2200)

\*With two-speed option.

\*\*Models 216-236B with 254 mm (10") wide tires, 242-268B with 305 mm (12") wide tires.

## Skid Steer Loaders (cont'd)

Model	Product Ident. No. Prefix	Years Built	Approx. Machine		Length to Coupler mm (in)	Width over Tires mm (in)**	Height to Top of Cab mm (in)	Engine Model	Top Travel Speed km/h (mph)	Rated Operating Capacity	
			Weight kg (lb)	Net Power kW (hp)						Operating Capacity at 50% kg (lb)	with counter-weight kg (lb)
246	5SZ	99-03	3214 <b>(7087)</b>	55 <b>(74)</b>	2800 <b>(110)</b>	1676 <b>(66)</b>	2092 <b>(82)</b>	3034T	12.1 <b>(7.5)</b>	907 <b>(2000)</b>	952 <b>(2100)</b>
246B	PAT	04-07	3239 <b>(7142)</b>	58 <b>(78)</b>	2800 <b>(110)</b>	1676 <b>(66)</b>	2092 <b>(82)</b>	3044CT	12.5/19.1* <b>(7.7/11.8*)</b>	907 <b>(2000)</b>	952 <b>(2100)</b>
246C	JAY	08-13	3393 <b>(7480)</b>	54 <b>(73)</b>	3692 <b>(145.3)</b>	1676 <b>(66)</b>	2104 <b>(82.8)</b>	Cat C3.4 DIT	19.3 <b>(12.0)</b>	975 <b>(2150)</b>	1066 <b>(2350)</b>
248	6LZ	99-03	3328 <b>(7338)</b>	55 <b>(74)</b>	2800 <b>(110)</b>	1676 <b>(66)</b>	2092 <b>(82)</b>	3034T	12.1 <b>(7.5)</b>	907 <b>(2000)</b>	952 <b>(2100)</b>
248B	SCL	04-07	3320 <b>(7321)</b>	57 <b>(76)</b>	2800 <b>(110)</b>	1676 <b>(66)</b>	2092 <b>(82)</b>	3044C DIT	12.5/19.1* <b>(7.7/11.8*)</b>	907 <b>(2000)</b>	952 <b>(2100)</b>
252	FDG	01-03	3454 <b>(7615)</b>	44 <b>(59)</b>	2776 <b>(110)</b>	1829 <b>(72)</b>	1968 <b>(78)</b>	3034	12.1 <b>(7.5)</b>	1020 <b>(2250)</b>	1043 <b>(2300)</b>
252B	SCP	04-07	3552 <b>(7832)</b>	52 <b>(70)</b>	2902 <b>(114)</b>	1829 <b>(72)</b>	2063 <b>(81)</b>	3044C DIT	11.2/17.8* <b>(6.9/11.0*)</b>	1134 <b>(2500)</b>	1134 <b>(2500)</b>
252B2	SCP	07-10	4172 <b>(9198)</b>	53 <b>(71)</b>	2901 <b>(114)</b>	1829 <b>(72)</b>	2063 <b>(83)</b>	C3.4 DIT	12.1 <b>(7.5)</b>	1134 <b>(2500)</b>	1157 <b>(2551)</b>
252B3	TNK	10-13	3565 <b>(7861)</b>	53 <b>(71)</b>	2901 <b>(114.2)</b>	1829 <b>(72)</b>	2063 <b>(82.6)</b>	Cat C3.4 DIT	17.8 <b>(11.1)</b>	1202 <b>(2650)</b>	1225 <b>(2700)</b>
262	CED	01-03	3472 <b>(7655)</b>	55 <b>(74)</b>	2902 <b>(114)</b>	1829 <b>(72)</b>	2098 <b>(83)</b>	3034T	12.1 <b>(7.5)</b>	1134 <b>(2500)</b>	1156 <b>(2550)</b>
262B	PDT	04-07	3565 <b>(7861)</b>	58 <b>(78)</b>	2902 <b>(114)</b>	1829 <b>(72)</b>	2063 <b>(81)</b>	3044C DIT	11.6/17.8* <b>(7.2/11.0*)</b>	1225 <b>(2700)</b>	1247 <b>(2750)</b>
262C	MST	08-13	3614 <b>(7968)</b>	61 <b>(82)</b>	2979 <b>(117.3)</b>	1676 <b>(66)</b>	2104 <b>(82.8)</b>	Cat C3.4 DIT	19.3 <b>(12.0)</b>	1225 <b>(2700)</b>	1336 <b>(2945)</b>
262C2	TMW	12-13	3614 <b>(7968)</b>	54 <b>(73)</b>	2979 <b>(117.3)</b>	1676 <b>(66)</b>	2104 <b>(82.8)</b>	Cat C3.4 DIT	19.3 <b>(12.0)</b>	1225 <b>(2700)</b>	1336 <b>(2945)</b>
268B	LBA	04-07	3626 <b>(7995)</b>	57 <b>(76)</b>	2902 <b>(114)</b>	1829 <b>(72)</b>	2063 <b>(81)</b>	3044C DIT	11.6/17.8* <b>(7.2/11.0*)</b>	1225 <b>(2700)</b>	1247 <b>(2750)</b>
272C	RED	08-13	3793 <b>(8362)</b>	67 <b>(90)</b>	3120 <b>(122.8)</b>	1676 <b>(66)</b>	2104 <b>(82.8)</b>	Cat C3.4 DIT	16.1 <b>(10.0)</b>	1474 <b>(3250)</b>	1579 <b>(3480)</b>
272D	GSL	12-13	3812 <b>(8404)</b>	71 <b>(95)</b>	3139 <b>(123.6)</b>	1930 <b>(76)</b>	2104 <b>(82.8)</b>	Cat C3.8 DIT	15.1 <b>(9.4)</b>	1451 <b>(3200)</b>	1565 <b>(3450)</b>
272D	SHY	12-13	4220 <b>(9403)</b>	79 <b>(106)</b>	3119 <b>(122.8)</b>	1930 <b>(76)</b>	2104 <b>(84.3)</b>	Cat C3.8 DIT	15.1 <b>(9.4)</b>	1633 <b>(3600)</b>	—
272D	B5W	13-15	3743 <b>(8252)</b>	71 <b>(95)</b>	3156 <b>(124.3)</b>	1829 <b>(72)</b>	2111 <b>(83.1)</b>	Cat C3.8 DIT	15.1 <b>(9.4)</b>	1451 <b>(3200)</b>	1565 <b>(3450)</b>
272D	ETL	13-15	4220 <b>(9403)</b>	79 <b>(106)</b>	3136 <b>(123.5)</b>	1930 <b>(76)</b>	2147 <b>(84.5)</b>	Cat C3.8 DIT	16.6 <b>(10.3)</b>	1678 <b>(3700)</b>	—

\*With two-speed option.

\*\*Models 216-236B with 254 mm (10") wide tires, 242-268B with 305 mm (12") wide tires.



## MULTITERRAIN LOADERS

Model	Product Ident. No. Prefix	Years Built	Approx. Machine Weight kg (lb)	Net Power kW (hp)	Length to Coupler mm (in)	Width over Tracks mm (in)*	Height to Top of Cab mm (in)	Engine Model	Top Travel Speed km/h (mph)	Rated Operating Capacity at 50% kg (lb)
247	CML	02-04	3023 (6665)	41 (54)	2518 (99)	1676 (66)	1990 (78)	3034	12.1 (7.5)	877 (1933)
247B	MTL	04-07	3024 (6668)	42 (57)	2518 (99)	1676 (66)	1990 (78)	3024CT	12.2 (7.6)	885 (1950)
247B2	MTL	07-10	3497 (7710)	42 (56)	2518 (8'3")	1676 (5'6")	1990 (6'6")	C2.2T	0-11.3 (0-7.0)	929 (2050)
247B3	MTL	10-15	3174 (6997)	42 (56)	2518 (99.0)	1676 (66.0)	1990 (78.0)	Cat C2.2T	11.3 (7.0)	975 (2150)
257	CMM	02-04	3460 (7628)	44 (59)	2701 (106)	1676 (66)	2022 (80)	3034T	12.1 (7.5)	1046 (2306)
257B	SLK	04-07	3428 (7559)	42 (57)	2701 (106)	1676 (66)	2022 (80)	3024CT	11.4 (7.1)	1047 (2310)
257B2	SLK	7-10	3906 (8611)	42 (56)	2701 (8'10")	1676 (5'6")	2022 (6'7")	C2.2T	0-11.3 (0-7.0)	1134 (2500)
257B3	B7H	10-13	3656 (8060)	53 (71)	2718 (107)	1676 (66)	2035 (80)	Cat C3.4 DIT	16.1 (10.0)	1213 (2675)
267	CMP	01-04	4134 (9088)	44 (59)	2923 (115)	1898 (75)	2074 (82)	3034	9.7 (6.0)	1315 (2900)
267B	CYC	04-07	4250 (9371)	52 (70)	2923 (115)	1898 (75)	2074 (82)	3044C DIT	11.2 (7.0)	1315 (2900)
277	CNC	01-04	4148 (9126)	55 (74)	2923 (115)	1898 (75)	2074 (82)	3034T	9.7 (6.0)	1338 (2950)
277B	MDH	04-07	4269 (9411)	58 (78)	2923 (115)	1898 (75)	2074 (82)	3044C DIT	11.2 (7.0)	1338 (2950)
277C	JWF	08-13	4307 (9495)	61 (82)	2974 (117.2)	1981 (78)	2115 (83.2)	Cat C3.4 DIT	14.9 (9.3)	1451 (3200)
277C2	MET	12-13	4307 (9495)	54 (73)	2974 (117.2)	1981 (78)	2115 (83.2)	Cat C3.4 DIT	14.9 (9.3)	1451 (3200)
287	CNY	03-04	4471 (9870)	55 (74)	2900 (114)	1962 (77)	2122 (84)	3034T	11.0 (7.0)	1587 (3500)
287B	ZSA	04-07	4660 (10,275)	58 (78)	2900 (114)	1962 (77)	2122 (84)	3044C DIT	11.2 (7.0)	1632 (3600)
287C	MAS	08-13	4517 (9958)	61 (82)	2974 (117.2)	1981 (78)	2115 (83.2)	Cat C3.4 DIT	14.9 (9.3)	1724 (3800)
287C2	SSB	12-13	4517 (9958)	54 (73)	2974 (117.2)	1981 (78)	2115 (83.2)	Cat C3.4 DIT	14.9 (9.3)	1724 (3800)
297C	GCP	07-12	4870 (10,736)	67 (90)	2974 (108)	1981 (78)	2115 (83)	C3.4 DIT	9.0 (5.6) 14.9 (9.2)	1060 (2337)
297D	BE7	14-15	4590 (10,120)	71 (95)	3155 (124.2)	1935 (76.2)	2125 (83.6)	Cat C3.8 DIT	15.1 (9.4)	2063 (4550)
297D XHP	HP7	14-15	4905 (10,815)	79 (106)	3155 (124.2)	1935 (76.2)	2125 (83.6)	Cat C3.8 DIT	15.1 (9.4)	2268 (5000)

\*With 457 mm (18") wide track.



## COMPACT TRACK LOADERS

Model	Product Ident. No. Prefix	Years Built	Approx. Machine Weight kg (lb)	Net Power kW (hp)	Length to Coupler mm (in)	Width over Tracks mm (in)	Height to Top of Cab mm (in)	Engine Model	Top Travel Speed km/h (mph)	Rated Operating Capacity at 50% kg (lb)
259B3*	YYZ	10-13	4052 <b>(8934)</b>	53 <b>(71)</b>	2722 <b>(107)</b>	1676 <b>(66)</b>	1986 <b>(78)</b>	Cat C3.4 DIT	13.6 <b>(8.5)</b>	1338 <b>(2950)</b>
279C	MBT	10-13	4487 <b>(9892)</b>	61 <b>(82)</b>	2960 <b>(116.5)</b>	1981 <b>(78)</b>	2117 <b>(83.3)</b>	Cat C3.4 DIT	13.6 <b>(8.5)</b>	1451 <b>(3200)</b>
279C2	KWB	12-13	4475 <b>(9865)</b>	54 <b>(73)</b>	2960 <b>(116.5)</b>	1981 <b>(78)</b>	2117 <b>(83.3)</b>	Cat C3.4 DIT	13.6 <b>(8.5)</b>	1383 <b>(3050)</b>
289C	JMP	10-13	4702 <b>(10,365)</b>	61 <b>(82)</b>	2960 <b>(116.5)</b>	1981 <b>(78)</b>	2117 <b>(83.3)</b>	Cat C3.4 DIT	13.6 <b>(8.5)</b>	1746 <b>(3850)</b>
289C2	RTD	12-13	4687 <b>(10,332)</b>	54 <b>(73)</b>	2960 <b>(116.5)</b>	1981 <b>(78)</b>	2117 <b>(83.3)</b>	Cat C3.4 DIT	13.6 <b>(8.5)</b>	1656 <b>(3650)</b>
299C	JSP	10-13	4867 <b>(10,730)</b>	67 <b>(90)</b>	3101.0 <b>(122.1)</b>	1981 <b>(78)</b>	2117 <b>(83.3)</b>	Cat C3.4 DIT	13.6 <b>(8.5)</b>	1882 <b>(4150)</b>
299D	HCL	12-13	4943 <b>(10,898)</b>	71 <b>(95)</b>	3138 <b>(123.5)</b>	1931 <b>(76)</b>	2104 <b>(82.8)</b>	Cat C3.8 DIT	13.6 <b>(8.5)</b>	1928 <b>(4250)</b>
299D XHP	NLC	12-13	5283 <b>(11,647)</b>	79 <b>(106)</b>	3138 <b>(123.5)</b>	1931 <b>(76)</b>	2104 <b>(82.8)</b>	Cat C3.8 DIT	13.6 <b>(8.5)</b>	1882 <b>(4150)</b>
299D	GTC	13-15	4862 <b>(10,718)</b>	71 <b>(95)</b>	3136 <b>(123.5)</b>	1931 <b>(76)</b>	2127 <b>(83.7)</b>	Cat C3.8 DIT	13.5 <b>(8.4)</b>	1928 <b>(4250)</b>
299D XHP	JST	13-15	5267 <b>(11,612)</b>	79 <b>(106)</b>	3136 <b>(123.5)</b>	1931 <b>(76)</b>	2127 <b>(83.7)</b>	Cat C3.8 DIT	13.5 <b>(8.4)</b>	2109 <b>(4650)</b>

\*Configured with 320 mm (12.6") tracks.



## HYDRAULIC EXCAVATORS (Track)

Model	Product Ident. No. Prefix COSA (US)	Years Built	Flywheel Horsepower	Approx. Operating Weight kg (lb)	Track Gauge m (ft)	Height* m (ft)	Length* m (ft)	Width m (ft)	Max. Reach** m (ft)	Lift Capacity*** kg (lb)
205 LC	(3HC) (4DC)	84-89	Deutz-67 Perkins®-71	13 135 <b>(28,957)</b>	1.895 <b>(6'2.5")</b>	3.00 <b>(9'10")</b>	7.30 <b>(23'11")</b>	2.40 <b>(7'10")</b>	8.17 <b>(26'10")</b>	3290 <b>(7300)</b>
205B	5ZF	90-92	80	12 900 <b>(28,443)</b>	1.895 <b>(6'2.5")</b>	2.976 <b>(9'9")</b>	7.67 <b>(25'2")</b>	2.495 <b>(8'2")</b>	8.9 <b>(29'2")</b>	3740 <b>(8250)</b>
211 LC	(4EC) (5CC)	84-89	Deutz-84 Perkins-94	15 540 <b>(34,260)</b>	2.08 <b>(6'9.9")</b>	3.02 <b>(9'11")</b>	8.01 <b>(26'3")</b>	2.49 <b>(8'2")</b>	9.88 <b>(32'5")</b>	4240 <b>(9340)</b>
213 LC	3ZC	83-87	102	17 300 <b>(38,140)</b>	2.08 <b>(6'10")</b>	3.08 <b>(10'1")</b>	8.34 <b>(27'4")</b>	2.49 <b>(8'2")</b>	10.30 <b>(33'9.5")</b>	5127 <b>(11,305)</b>
215	(96L) (57Z) (14Z)	76-80 79-84	85 90	17 450 <b>(38,480)</b>	1.92 <b>(6'4")</b>	3.10 <b>(10'1")</b>	8.94 <b>(29'4")</b>	2.47 <b>(8'0")</b>	9.25 <b>(30'4")</b>	5090 <b>(11,200)</b>
215 SA	(57Y) (14Z)	82-84	90	19 440 <b>(42,860)</b>	2.18 <b>(7'2")</b>	3.22 <b>(10'6")</b>	8.94 <b>(29'4")</b>	2.73 <b>(8'11")</b>	9.23 <b>(30'3")</b>	5130 <b>(11,300)</b>
215B LC	(9YB)	84-87	105	18 510 <b>(40,806)</b>	1.92 <b>(6'4")</b>	3.10 <b>(10'2")</b>	8.94 <b>(29'4")</b>	2.44 <b>(8'0")</b>	9.25 <b>(30'4")</b>	5760 <b>(12,700)</b>
215C LC	(4HG)	87-89	115	19 570 <b>(43,150)</b>	1.92 <b>(6'4")</b>	3.1 <b>(10'2")</b>	8.94 <b>(29'4")</b>	2.42 <b>(7'11")</b>	9.29 <b>(30'6")</b>	7070 <b>(15,200)</b>
215D LC	(9TF)	89-92	125	19 900 <b>(43,900)</b>	1.92 <b>(6'4")</b>	3.2 <b>(10'6")</b>	9.0 <b>(24'6")</b>	2.44 <b>(8'0")</b>	9.23 <b>(30'3")</b>	6830 <b>(14,700)</b>
219	(5CF)	87-89	130	21 120 <b>(46,550)</b>	2.18 <b>(7'2")</b>	3.12 <b>(10'3")</b>	8.94 <b>(29'4")</b>	2.73 <b>(8'11")</b>	10.39 <b>(34'1")</b>	7080 <b>(15,300)</b>
219D	(5XG)	89-92	140	21 600 <b>(47,500)</b>	2.18 <b>(7'2")</b>	3.12 <b>(10'3")</b>	9.41 <b>(30'10")</b>	2.73 <b>(8'11")</b>	9.75 <b>(32'0")</b>	7670 <b>(16,500)</b>
219 LC	(5CF)	87-89	130	22 020 <b>(48,550)</b>	2.18 <b>(7'2")</b>	3.12 <b>(10'3")</b>	8.94 <b>(29'4")</b>	2.73 <b>(8'11")</b>	10.39 <b>(34'1")</b>	7080 <b>(15,300)</b>
219D LC	(5XG)	89-92	140	22 400 <b>(49,300)</b>	2.18 <b>(7'2")</b>	3.12 <b>(10'3")</b>	9.41 <b>(30'10")</b>	2.73 <b>(8'11")</b>	9.75 <b>(32'0")</b>	7670 <b>(16,500)</b>
225 LC	(51U)	72-86	135	23 900 <b>(52,700)</b>	2.64 <b>(8'8")</b>	3.17 <b>(10'5")</b>	9.83 <b>(32'3")</b>	2.99 <b>(9'10")</b>	9.58 <b>(31'5")</b>	7300 <b>(15,600)</b>
225 SA	(51U)	77-86	135	27 125 <b>(59,800)</b>	2.64 <b>(8'8")</b>	3.17 <b>(10'5")</b>	9.83 <b>(32'3")</b>	3.35 <b>(11'0")</b>	9.55 <b>(31'4")</b>	7340 <b>(15,700)</b>
225B	(2ZD) (3YD)	86-89 87-89	145	24 960 <b>(55,030)</b>	2.44 <b>(8'0")</b>	3.17 <b>(10'5")</b>	9.83 <b>(32'3")</b>	2.99 <b>(9'10")</b>	10.16 <b>(33'4")</b>	11 040 <b>(26,100)</b>
225D	(6RG)	89-91	150	25 400 <b>(55,900)</b>	2.44 <b>(8'0")</b>	3.23 <b>(10'7")</b>	9.94 <b>(32'7")</b>	2.99 <b>(9'10")</b>	10.13 <b>(33'3")</b>	— —
225B LC	(2ZD) (3YD)	86-89 87-89	145	26 140 <b>(58,230)</b>	2.44 <b>(8'0")</b>	3.17 <b>(10'5")</b>	9.83 <b>(32'3")</b>	2.99 <b>(9'10")</b>	10.16 <b>(33'4")</b>	11 040 <b>(26,100)</b>
225D LC	(2SJ)	89-91	165	26 700 <b>(58,900)</b>	2.44 <b>(8'0")</b>	3.23 <b>(10'7")</b>	9.94 <b>(32'7")</b>	2.99 <b>(9'10")</b>	10.13 <b>(33'3")</b>	12 450 <b>(26,900)</b>

\*When shipped with medium stick and bucket curled under.

\*\*Maximum reach at ground level, one-piece boom, longest stick.

\*\*\*Lift capacity at 4.6 m (15'0") over front, one-piece boom, longest stick.

## Hydraulic Excavators (Track) (cont'd)

Model	Product Ident. No. Prefix COSA (US)	Years Built	Flywheel Horsepower	Approx. Operating Weight kg (lb)	Track Gauge m (ft)	Height* m (ft)	Length* m (ft)	Width m (ft)	Max. Reach** m (ft)	Lift Capacity*** kg (lb)
229	(1GF)	86-89	145	29 140	2.64	3.38	9.83	3.45	10.11	—
	(1AF)	86-89		<b>(64,830)</b>	<b>(8'8")</b>	<b>(11'1")</b>	<b>(32'3")</b>	<b>(11'4")</b>	<b>(33'2")</b>	—
229 LC	(1GF)	86-89	180	33 540	2.64	3.38	11.02	3.45	11.35	7940
Custom 180				<b>(73,940)</b>	<b>(8'8")</b>	<b>(11'1")</b>	<b>(36'2")</b>	<b>(11'4")</b>	<b>(37'3")</b>	<b>(17,100)</b>
229D	(2LJ)	89-91	157	31 700	2.64	3.52	10.9	3.25	10.76	8300
				<b>(69,900)</b>	<b>(8'8")</b>	<b>(11'7")</b>	<b>(35'9")</b>	<b>(10'8")</b>	<b>(35'4")</b>	<b>(18,300)</b>
231D		90-92	200	34 300	2.64	3.45	10.83	3.45	11.20	15 300
				<b>(75,600)</b>	<b>(8'8")</b>	<b>(11'4")</b>	<b>(35'6")</b>	<b>(11'4")</b>	<b>(36'9")</b>	<b>(33,000)</b>
231D LC		90-92	200	35 500	2.64	3.45	10.83	3.45	11.20	15 300
				<b>(78,100)</b>	<b>(8'8")</b>	<b>(11'4")</b>	<b>(35'6")</b>	<b>(11'4")</b>	<b>(36'9")</b>	<b>(33,000)</b>
235	(32K)	73-86	195	39 320	2.69	3.40	11.27	3.45	11.23	7050
	(64R)			<b>(86,700)</b>	<b>(8'10")</b>	<b>(11'2")</b>	<b>(37'0")</b>	<b>(11'4")</b>	<b>(36'10")</b>	<b>(17,300)</b>
235B	(7WC)	86-88	215	40 960	2.69	3.40	11.27	3.45	11.23	9934
	(9PC)			<b>(89,700)</b>	<b>(8'10")</b>	<b>(11'2")</b>	<b>(37'0")</b>	<b>(11'4")</b>	<b>(36'10")</b>	<b>(21,900)</b>
235C	(4DG) (5AF)	88-92	250	42 140	2.69	3.50	11.50	3.45	12.00	14 720
	(2PG) (3WG)			<b>(92,800)</b>	<b>(8'10")</b>	<b>(11'4")</b>	<b>(37'7")</b>	<b>(11'4")</b>	<b>(39'5")</b>	<b>(35,000)</b>
235D	(8KJ)	92-93	250	46 270	2.69	3.50	11.50	3.45	12.00	14 840
	(8TJ)			<b>(103,780)</b>	<b>(8'10")</b>	<b>(11'5")</b>	<b>(37'7")</b>	<b>(11'4")</b>	<b>(39'5")</b>	<b>(35,200)</b>
235D LC	(8KJ)	92-93	250	49 270	3.30	3.60	11.60	3.79	11.97	15 070
	(8TJ)			<b>(108,620)</b>	<b>(10'10")</b>	<b>(11'9")</b>	<b>(38'1")</b>	<b>(12'5")</b>	<b>(39'3")</b>	<b>(35,700)</b>
245	(82X)	74-88	325	65 745	3.24	4.62	13.18	3.71	14.02	14 930
	(84X)			<b>(144,941)</b>	<b>(10'7")</b>	<b>(15'2")</b>	<b>(43'3")</b>	<b>(12'2")</b>	<b>(46'0")</b>	<b>(32,920)</b>
245B	6MF	88-92	360	65 200	3.24	4.78	13.13	3.61	14.02	—
	1SJ			<b>(143,500)</b>	<b>(10'7")</b>	<b>(15'8")</b>	<b>(43'1")</b>	<b>(11'10")</b>	<b>(46'0")</b>	—
245D	(4LK)	92-93	385	68 420	3.24	5.46	12.82	3.61	13.84	14 640†
	(7ZJ)			<b>(150,520)</b>	<b>(10'7")</b>	<b>(17'11")</b>	<b>(42'0")</b>	<b>(11'10")</b>	<b>(45'9")</b>	<b>(31,600)</b>
E70	3BG	87-89	52	6500	1.65	2.59	6.02	2.25	6.67	1300
	3CG	87-89		<b>(14,300)</b>	<b>(5'5")</b>	<b>(8'6")</b>	<b>(19'9")</b>	<b>(7'5")</b>	<b>(21'10")</b>	<b>(2750)</b>
E70B	7YF(JPN)	89-94	54	6760	1.75	2.56	6.09	2.32	6.72	1315
	5TG(OSJ)	89-94		<b>(14,900)</b>	<b>(5'9")</b>	<b>(8'5")</b>	<b>(20'0")</b>	<b>(7'7")</b>	<b>(22'1")</b>	<b>(2900)</b>
	6AK(OSJ)	92-94								
E110	3FG	87-89	74	10 700	1.9	2.73	7.345	2.5	7.93	2700
	3GG	87-89		<b>(23,600)</b>	<b>(6'3")</b>	<b>(8'11")</b>	<b>(24'0")</b>	<b>(8'2")</b>	<b>(26'0")</b>	<b>(5750)</b>
E110B	9HF(OSJ)	90-92	79	11 600	1.99	2.70	7.25	2.495	8.10	3350
	8MF(JPN)	90-92		<b>(25,600)</b>	<b>(6'6")</b>	<b>(8'10")</b>	<b>(23'9")</b>	<b>(8'2")</b>	<b>(26'7")</b>	<b>(7200)</b>
	5GK(OSJ)	90-92								

\*When shipped with medium stick and bucket curled under.

\*\*Maximum reach at ground level, one-piece boom, longest stick.

\*\*\*Lift capacity at 4.6 m (15'0") over front, one-piece boom, longest stick.

†Lift capacity at 7.5 m (25'0") over front, one-piece boom, longest stick.

## Hydraulic Excavators (Track) (cont'd)

Model	Product Ident. No. Prefix COSA (US)	Years Built	Flywheel Horsepower	Approx. Operating Weight kg (lb)	Track Gauge m (ft)	Height* m (ft)	Length* m (ft)	Width m (ft)	Max. Reach** m (ft)	Lift Capacity*** kg (lb)
E120	1LF(OSJ)	87-89	84	12 200	1.99	2.775	7.66	2.490	8.58	3850
	1MF(JPN)	87-89		<b>(26,800)</b>	<b>(6'6")</b>	<b>(9'1")</b>	<b>(25'1")</b>	<b>(8'2")</b>	<b>(28'2")</b>	<b>(8300)</b>
E120B	7NF(OSJ)	90-92	84	12 680	1.99	2.70	7.62	2.495	8.74	4310
	6JF(JPN)	90-92		<b>(28,200)</b>	<b>(6'6")</b>	<b>(8'10")</b>	<b>(25'10")</b>	<b>(8'2")</b>	<b>(28'8")</b>	<b>(9250)</b>
	4XK(OSJ)	90-92								
E140	1PF(JPN)	87-94	89	13 970	1.99	2.89	8.29	2.55	5.49	4380
	1NF(OSJ)			<b>(30,800)</b>	<b>(6'6")</b>	<b>(9'6")</b>	<b>(27'6")</b>	<b>(8'4")</b>	<b>(18'0")</b>	<b>(9650)</b>
E200B	6KF(OSJ)	87-91	118	18 800	2.20	2.97	9.48	2.83	10.63	8100
	4SG(JPN)	87-91		<b>(41,400)</b>	<b>(7'3")</b>	<b>(9'9")</b>	<b>(3'11")</b>	<b>(9'4")</b>	<b>(34'10")</b>	<b>(17,350)</b>
EL200B	7DF(OSJ)	87-91	118	20 100	2.38	2.97	9.48	3.18	10.63	8150
	5EG(JPN)	87-91		<b>(44,300)</b>	<b>(7'10")</b>	<b>(9'9")</b>	<b>(31'1")</b>	<b>(10'5")</b>	<b>(34'10")</b>	<b>(17,600)</b>
E240	1FG(OSJ)	87-89	148	23 000	2.39	3.02	9.73	3.19	10.6	9800
	2HF(JPN)	87-89		<b>(50,700)</b>	<b>(7'10")</b>	<b>(9'11")</b>	<b>(31'11")</b>	<b>(10'6")</b>	<b>(34'9")</b>	<b>(21,600)</b>
E240B	8SF(OSJ)	89-92	148	23 000	2.39	3.02	9.73	3.19	10.6	9800
	9PF(JPN)			<b>(50,700)</b>	<b>(7'10")</b>	<b>(9'11")</b>	<b>(31'11")</b>	<b>(10'6")</b>	<b>(34'9")</b>	<b>(21,600)</b>
E240C	2RL(OSJ)	92-93	148	23 000	2.39	3.02	9.73	3.19	10.6	9800
	8MK(JPN)			<b>(50,700)</b>	<b>(7'10")</b>	<b>(9'11")</b>	<b>(31'11")</b>	<b>(10'6")</b>	<b>(34'9")</b>	<b>(21,600)</b>
EL240	4JF(OSJ)	87-89	148	23 600	2.58	3.02	9.73	3.38	10.6	11 300
	4MF(JPN)	87-89		<b>(52,000)</b>	<b>(8'6")</b>	<b>(9'11")</b>	<b>(31'11")</b>	<b>(11'1")</b>	<b>(34'9")</b>	<b>(24,300)</b>
EL240B	5WG(OSJ)	89-92	148	23 600	2.58	3.02	9.73	3.38	10.6	10 320
	6MG(JPN)			<b>(52,000)</b>	<b>(8'6")</b>	<b>(9'11")</b>	<b>(31'11")</b>	<b>(11'1")</b>	<b>(34'9")</b>	<b>(22,750)</b>
EL240C	9PK(OSJ)	92-93	148	23 600	2.58	3.02	9.73	3.38	10.6	10 320
	9NK(JPN)			<b>(52,000)</b>	<b>(8'6")</b>	<b>(9'11")</b>	<b>(31'11")</b>	<b>(11'1")</b>	<b>(34'9")</b>	<b>(22,750)</b>
E300	2CF(OSJ)	87-89	187	30 500	2.6	3.22	10.94	3.4	11.84	12 550
	1KG(JPN)	87-89		<b>(67,300)</b>	<b>(8'6")</b>	<b>(10'7")</b>	<b>(35'11")</b>	<b>(11'2")</b>	<b>(38'9")</b>	<b>(27,650)</b>
E300B	1WJ(OSJ)	90-91	206	30 200	2.6	3.22	10.94	3.4	11.84	12 450
	2HJ(JPN)	90-91		<b>(66,580)</b>	<b>(8'6")</b>	<b>(10'7")</b>	<b>(35'11")</b>	<b>(11'2")</b>	<b>(38'9")</b>	<b>(26,850)</b>
EL300	4NF(OSJ)	87-89	187	31 600	2.6	3.22	10.94	3.4	11.84	12 550
	4SF(JPN)	87-89		<b>(69,700)</b>	<b>(8'6")</b>	<b>(10'7")</b>	<b>(35'11")</b>	<b>(11'2")</b>	<b>(38'9")</b>	<b>(27,650)</b>
EL300B	3FJ(OSJ)	90-91	206	31 200	2.6	3.22	10.94	3.4	11.84	12 450
	1GK(JPN)	90-91		<b>(68,780)</b>	<b>(8'6")</b>	<b>(10'7")</b>	<b>(35'11")</b>	<b>(11'2")</b>	<b>(38'9")</b>	<b>(26,850)</b>
E450	3HG(OSJ)	87-93	276	46 000	2.89	3.49	11.96	3.15	13.08	10 900
	3JG(JPN)	87-93		<b>(101,430)</b>	<b>(9'6")</b>	<b>(11'5")</b>	<b>(39'3")</b>	<b>(10'4")</b>	<b>(42'11")</b>	<b>(23,500)</b>
E650	3KG(OSJ)	87-92	375	62 600	3.25	4.84	14.0	3.49	13.33	15 850
	3LG(JPN)	87-92		<b>(138,000)</b>	<b>(10'8")</b>	<b>(15'11")</b>	<b>(45'11")</b>	<b>(11'5")</b>	<b>(43'9")</b>	<b>(34,000)</b>

\*When shipped with medium stick and bucket curled under.

\*\*Maximum reach at ground level, one-piece boom, longest stick.

\*\*\*Lift capacity at 4.6 m (15'0") over front, one-piece boom, longest stick.



## Hydraulic Excavators (Track) (cont'd)

Model	Product Ident. No. Prefix COSA (US)	Years Built	Flywheel Horsepower	Approx. Operating Weight kg (lb)	Track Gauge m (ft)	Height* m (ft)	Length* m (ft)	Width m (ft)	Max. Reach** m (ft)	Lift Capacity*** kg (lb)
301.5	3YW	98-05	17.4	1650 (3640)	0.75 (2'6")	2.19 (7'2")	3.69 (12'1")	0.98 (3'3")	3.8 (12'6")	380† (830)
301.6	BDH	00-05	17.4	1690 (3726)	0.75 (2'6")	2.19 (7'2")	3.69 (12'1")	0.98 (3'3")	3.8 (12'6")	370† (810)
301.8	BFA	00-05	17.4	1725 (3803)	0.75 (2'6")	2.19 (9'8")	3.69 (12'1")	0.98 (3'3")	3.8 (12'6")	370† (810)
302.5	4AZ	99-05	22.9	2730 (6020)	1.15 (3'9")	2.3 (7'7")	4.52 (14'10")	1.45 (4'9")	4.83 (15'10")	870† (1910)
303 CR	DMA	01-05	26.1	3210 (7077)	1.25 (4'1")	2.48 (8'2")	4.68 (15'4")	1.55 (5'1")	5.39 (17'8")	1200† (2646)
303C CR	BXT	06-10	29.5	7573 (3435)	1.25 (4'1")	2.5 (8'2")	4.73 (15'6")	15.5 (5'1")	5.1 (16'9")	1200 (2646)
303.5	AFW	99-02	25	7430 (7546)	1.25 (4'1")	2.44 (8'0")	5.07 (16'6")	1.55 (5'1")	5.54 (18'2")	1030† (2270)
303.5C CR	DCH	01-02		3790 (8356)	1.48 (4'10")	2.5 (8'2")	4.82 (15'10")	17.8 (5'10")	5.35 (17'7")	1630 (3594)
303.5D CR	DMY	06-10	38.9	3770 (8300)	1.48 (4'10")	2.5 (8'2")	4.73 (15'6")	1.78 (5'10")	5.32 (17'5")	1340† (2950)
303.5E CR	RHP	10-12	30	3800 (8380)	1.48 (4'10")	2.5 (8'2")	4.73 (15'6")	1.78 (5'10")	5.32 (17'5")	1340† (2950)
303.5E CR	RKY	11-	31.6	3800 (8380)	1.48 (4'10")	2.5 (8'2")	4.73 (15'6")	1.78 (5'10")	5.32 (17'5")	1340† (2950)
304 CR	NAD	02-05	35.5	4300 (9480)	1.58 (5'2")	2.6 (8'6")	5.18 (17'0")	1.98 (6'6")	5.95 (19'6")	2250† (5000)
304C CR	FPK	06-10	41.6	4800 (10,582)	1.58 (5'2")	2.55 (8'4")	5.17 (17'0")	19.8 (6'6")	5.46 (17'11")	2250 (5000)
304D CR	TYK	10-12	39	4080 (8995)	1.60 (5'3")	2.5 (8'2")	4.82 (15'10")	1.95 (6'5")	5.47 (18'0")	1570† (3460)
304E CR	TTN	11-15	40	4000 (8820)	1.6 (5'3")	2.5 (8'2")	4.82 (15'10")	1.95 (6'5")	5.47 (18'0")	1570† (3460)
304.5	ANK	99-02	38	4475 (9866)	1.5 (4'11")	2.5 (8'4")	5.7 (18'8")	1.9 (6'6")	6.05 (19'10")	1600† (3630)
304.5	WAK	01-02		4800 (10,582)	1.58 (5'2")	2.6 (8'6")	5.37 (17'7")	1.98 (6'6")	6.14 (20'2")	2550† (5622)
305 CR	DSA	01-03	42	4800 (10,582)	1.58 (5'2")	2.6 (8'6")	5.37 (17'7")	1.98 (6'6")	6.14 (20'2")	2550† (5622)
305 CR	DGT	03-05	42	4800 (10,582)	1.58 (5'2")	2.6 (8'6")	5.37 (17'7")	1.98 (6'6")	6.14 (20'2")	2550† (5622)
305C CR	HWJ	06-10	46.9	5200 (11,464)	1.58 (5'2")	2.55 (8'4")	5.33 (17'6")	19.8 (6'6")	5.65 (18'6")	2550 (5622)
305D CR	XER	10-11	42	5260 (11,600)	1.58 (5'2")	2.55 (8'4")	5.18 (17'0")	1.98 (6'6")	5.81 (19'1")	2250† (4960)
305E CR	XFA	11-14	40	5210 (11,490)	1.58 (5'2")	2.55 (8'4")	5.18 (17'0")	1.98 (6'6")	5.81 (19'1")	2250† (4960)
305.5D CR	FLZ	10-12	47	5560 (12,260)	1.58 (5'2")	2.55 (8'4")	5.33 (17'6")	1.98 (6'6")	6.02 (19'9")	2480† (5470)
305.5E CR	FKY	11-14	44.2	5480 (12,080)	1.58 (5'2")	2.55 (8'4")	5.33 (17'6")	1.98 (6'6")	6.02 (19'9")	2490† (5490)

\*When shipped with medium stick and bucket curled under.

\*\*Maximum reach at ground level, one-piece boom, longest stick.

\*\*\*Lift capacity at 4.6 m (15'0") over front, one-piece boom, longest stick.

†Lift capacity at 3 m (10'0") over front, blade down, one-piece boom, longest stick.

## Hydraulic Excavators (Track) (cont'd)

Model	Product Ident. No. Prefix COSA (US)	Years Built	Flywheel Horsepower	Approx. Operating Weight kg (lb)	Track Gauge m (ft)	Height* m (ft)	Length* m (ft)	Width m (ft)	Max. Reach** m (ft)	Lift Capacity*** kg (lb)
307	2WM	94-98	54	7600 (16,760)	1.75 (5'9")	2.61 (8'7")	6.3 (20'8")	2.4 (7'11")	6.38 (20'11")	2450 (5400)
	2PM(OSJ)	94-98	54	6740 (14,860)	1.75 (5'9")	2.63 (8'8")	6.08 (19'11")	2.28 (7'6")	6.72 (22'1")	1350 (3000)
	9ZL(JPN)	94-97	54	6650 (14,660)	1.75 (5'9")	2.63 (8'8")	6.08 (19'11")	2.28 (7'6")	6.72 (22'1")	1350 (3000)
307B	5CW(OSJ)	98-00	54	6960 (15,340)	1.75 (5'9")	2.63 (8'8")	6.08 (19'11")	2.28 (7'6")	6.72 (22'1")	1350 (3000)
	4RW(JPN)	97-00	54	6500 (14,330)	1.75 (5'9")	2.64 (8'8")	6.08 (19'11")	2.28 (7'6")	6.72 (22'1")	1350 (3000)
307B SB	AFB	99-00	40/54	7500 (16,530)	1.75 (5'9")	2.9 (9'6")	6.75 (22'2")	2.28 (7'6")	7.01 (23'0")	1410 (3100)
	6KZ(OSJ) 7DZ(JPN) (BCM)	98-01 00-09	40/54 54	8040 (17,730) 7210 (15,900)	1.75 (5'9") 1.75 (5'9")	2.64 (8'8") 2.78 (9'1")	6.73 (22'1") 6.07 (19'11")	2.28 (7'6") 2.29 (7'6")	7.42 (24'4") 6.85 (22'6")	1500 (3300) 947 (2100)
307C	BAJ	00-08	54	6450 (14,220)	1.75 (5'9")	2.63 (8'8")	6.07 (19'11")	2.29 (7'6")	6.34 (20'10")	1052 (2300)
	(BNE)	00-07	54	8390 (18,500)	1.75 (5'9")	2.63 (8'8")	6.79 (22'3")	2.29 (7'6")	7.55 (24'9")	822 (1800)
307D	DSG	07-12	55.6	7075 (15,600)	1.84 (6'0")	2.63 (8'8")	6.07 (19'11")	2.29 (7'6")	6.67 (21'11")	3650† (8050)
307E	H1Y	12-	55.6	7160 (15,785)	1.75 (5'9")	2.63 (8'8")	6.07 (19'11")	2.29 (7'6")	6.16 (20'3")	4200† (9260)
308B CR	3YS(JPN)	99-02	54	7650 (16,870)	1.85 (6'1")	2.61 (8'7")	5.77 (18'11")	2.3 (7'7")	6.9 (22'8")	1600 (3500)
308C CR	(KCX)	02-07	54	8040 (17,730)	1.87 (6'2")	2.61 (8'7")	5.83 (19'2")	2.47 (8'1")	6.9 (22'8")	947 (2100)
	CPE	01-08	54	7390 (16,290)	1.87 (6'2")	2.61 (8'7")	5.83 (19'2")	2.32 (7'7")	6.39 (21'0")	1135 (2500)
308D CR	GBT	07-12	55.6	7850 (17,310)	1.87 (6'2")	2.63 (8'7")	5.81 (19'1")	2.32 (7'7")	6.71 (22'0")	3650† (8050)
308D SB	FYC	07-12	55.6	8400 (18,520)	1.87 (6'2")	2.59 (8'6")	6.45 (21'2")	2.32 (7'7")	7.43 (24'5")	3200† (7055)
308E SB	GBJ	11-13	65	8330 (18,365)	1.87 (6'2")	2.55 (8'4")	6.38 (20'11")	2.32 (7'7")	7.35 (24'1")	3610† (7960)
311	9LJ(OSJ)	93-96	79	11 100 (24,470)	1.99 (6'6")	2.76 (9'1")	7.25 (23'9")	2.49 (8'2")	8.1 (26'7")	3100 (6800)
	5PK(JPN)	93-96	79	11 050 (24,360)	1.99 (6'6")	2.76 (9'1")	7.25 (23'9")	2.49 (8'2")	8.10 (26'7")	3100 (6800)

\*When shipped with medium stick and bucket curled under.

\*\*Maximum reach at ground level, one-piece boom, longest stick.

\*\*\*Lift capacity at 4.6 m (15'0") over front, one-piece boom, longest stick.

†Lift capacity at 3 m (10'0") over front, blade down, one-piece boom, longest stick.

## Hydraulic Excavators (Track) (cont'd)

Model	Product Ident. No. Prefix COSA (US)	Years Built	Flywheel Horsepower	Approx. Operating Weight kg (lb)	Track Gauge m (ft)	Height* m (ft)	Length* m (ft)	Width m (ft)	Max. Reach** m (ft)	Lift Capacity*** kg (lb)
311B	2LS(blade) (OSJ)	96-01	79	11 890 (26,210)	1.99 (6'6")	2.76 (9'1")	7.25 (23'9")	2.495 (8'2")	8.1 (26'7")	3080 (6800)
	2MS(blade) (JPN)	96-01	79	11 900 (26,230)	1.99 (6'6")	2.76 (9'1")	7.25 (23'9")	2.5 (8'2")	8.1 (26'7")	3100 (6800)
	8GR(OSJ)	96-01	79	11 130 (24,540)	1.99 (6'6")	2.76 (9'1")	7.25 (23'9")	2.495 (8'2")	8.1 (26'7")	3120 (6900)
	8HR(JPN)	96-01	79	11 200 (24,690)	1.99 (6'6")	2.76 (9'1")	7.25 (23'9")	2.49 (8'2")	8.1 (26'7")	3100 (6800)
	311C U (CKE)	01-07	79	11 980 (26,410)	1.99 (6'6")	2.77 (9'1")	6.92 (22'8")	2.49 (8'2")	8.225 (27'0")	1295 (2900)
	CLK	01-07	79	11 500 (25,350)	1.99 (6'6")	2.765 (9'1")	6.88 (22'7")	2.49 (8'2")	7.7 (25'3")	1453 (3200)
311D RR	AKW(JPN)	08-14	80	11 930 (26,310)	1.99 (6'6")	2.86 (9'5")	6.84 (22'5")	2.49 (8'2")	8.1 (26'7")	3350 (7150)
311D LRR	CLA(OSJ)	08-13	80	12 480	1.99	2.86	6.91	2.49	8.1	3900
	DDW	08-09		(27,520)	(6'6")	(9'5")	(22'8")	(8'2")	(26'7")	(8350)
	(PNJ)	10-13								
	LKA	09-12								
	KRM(OSJ)	10-14								
312	6BL	93-97	84	12 600	1.99	2.76	7.6	2.49	8.63	4200
	6GK(OSJ)	93-96		(27,780)	(6'6")	(9'1")	(24'11")	(8'2")	(28'4")	(9300)
	7DK(JPN)	93-96	84	12 000 (26,460)	1.99 (6'6")	2.76 (9'1")	7.6 (24'11")	2.49 (8'2")	8.63 (28'4")	4050 (8900)
312B	6SW	98-01	84	13 000 (28,660)	1.99 (6'6")	2.91 (9'7")	7.59 (24'11")	2.49 (8'2")	8.3 (27'3")	4590 (10,110)
	9GR(OSJ)	98-01	84	12 440 (27,430)	1.99 (6'6")	2.76 (9'1")	7.595 (24'11")	2.495 (8'2")	8.625 (28'4")	4170 (9200)
	9HR(JPN)	98-00	84	12 150 (26,790)	1.99 (6'6")	2.76 (9'1")	7.595 (24'11")	2.49 (8'2")	8.625 (28'4")	4050 (8900)
	9NW(blade)	98-01	66/88	13 785 (30,390)	1.99 (6'6")	2.91 (9'7")	7.59 (24'11")	2.49 (8'2")	8.3 (27'3")	4940 (10,900)
	2NS(blade) (OSJ)	98-01	66/88	13 200 (29,100)	1.99 (6'6")	2.76 (9'1")	7.595 (24'11")	2.495 (8'2")	8.625 (28'4")	4230 (9300)
	3ES(blade) (JPN)	98-00	84	12 900 (28,440)	1.99 (6'6")	2.76 (9'1")	7.595 (24'11")	2.49 (8'2")	8.625 (28'4")	4200 (9300)
	312B L 9FS	97-01	84	13 270 (29,260)	1.99 (6'6")	2.91 (9'7")	7.59 (24'11")	2.59 (8'6")	8.3 (27'3")	5000 (11,000)
	8JR(OSJ)	98-01	66/88	12 940 (28,530)	1.99 (6'6")	2.76 (9'1")	7.595 (24'11")	2.59 (8'6")	8.625 (28'4")	4930 (10,900)
	2KW(blade)	97-01	84	14 055 (30,990)	1.99 (6'6")	2.91 (9'7")	7.59 (24'11")	2.59 (8'6")	8.3 (27'3")	5050 (11,100)
	3FS(blade) (OSJ)	98-01	66/88	13 720 (30,250)	1.99 (6'6")	2.76 (9'1")	7.595 (24'11")	2.59 (8'6")	8.625 (28'4")	4920 (10,800)

\*When shipped with medium stick and bucket curled under.

\*\*Maximum reach at ground level, one-piece boom, longest stick.

\*\*\*Lift capacity at 4.6 m (15'0") over front, one-piece boom, longest stick.

Hydraulic Excavators (Track) (cont'd)

Model	Product Ident. No. Prefix COSA (US)	Years Built	Flywheel Horsepower	Approx. Operating Weight kg (lb)	Track Gauge m (ft)	Height* m (ft)	Length* m (ft)	Width m (ft)	Max. Reach** m (ft)	Lift Capacity*** kg (lb)
312C	BNN(FDS)	01-07	90	12 860 <b>(28,350)</b>	1.99 <b>(6'6")</b>	2.76 <b>(9'1")</b>	7.57 <b>(24'10")</b>	2.59 <b>(8'6")</b>	8.74 <b>(28'8")</b>	1402 <b>(3100)</b>
	CAE	00-	90	12 200 <b>(26,900)</b>	1.99 <b>(6'6")</b>	2.75 <b>(9'0")</b>	7.57 <b>(24'10")</b>	2.49 <b>(8'2")</b>	8.3 <b>(27'3")</b>	1448 <b>(3200)</b>
	BNN	01-	71/96	13 000 <b>(28,665)</b>	1.99 <b>(6'6")</b>	2.91 <b>(9'6")</b>	7.59 <b>(24'11")</b>	2.49 <b>(8'2")</b>	8.3 <b>(27'3")</b>	4350 <b>(10,120)</b>
312C L	CBT(CBA)	01-07	90	13 140 <b>(28,970)</b>	1.99 <b>(6'6")</b>	2.76 <b>(9'1")</b>	7.57 <b>(24'10")</b>	2.59 <b>(8'6")</b>	8.74 <b>(28'8")</b>	1439 <b>(3200)</b>
	CBT	01-	71/96	13 270 <b>(29,260)</b>	1.99 <b>(6'6")</b>	2.91 <b>(9'6")</b>	7.59 <b>(24'11")</b>	2.59 <b>(8'6")</b>	8.3 <b>(27'3")</b>	5040 <b>(11,025)</b>
312D	HCW(OSJ)	08-12	90	13 120	1.99	2.83	7.61	2.49	8.62	4300
	HJX	08-11		<b>(28,930)</b>	<b>(6'6")</b>	<b>(9'3")</b>	<b>(25'0")</b>	<b>(8'2")</b>	<b>(28'3")</b>	<b>(9250)</b>
	PHH	09-11								
	DLP(CHN)	08-12								
	LRK(CHN)	10-12								
312D L	JBC(OSJ)	08-12	90	13 650	1.99	2.83	7.61	2.49	8.62	5000
	(XGK)	10-11		<b>(30,100)</b>	<b>(6'6")</b>	<b>(9'3")</b>	<b>(25'0")</b>	<b>(8'2")</b>	<b>(28'3")</b>	<b>(10,750)</b>
	KCD	08-11								
	TGY	08-08								
	SKA	11-11								
	RKF	09-11								
313B CR	BAS(OSJ)	00-02	89	13 225 <b>(29,160)</b>	1.99 <b>(6'6")</b>	2.82 <b>(9'3")</b>	7.17 <b>(23'6")</b>	2.49 <b>(8'2")</b>	8.55 <b>(28'1")</b>	3900 <b>(8600)</b>
	AEX(JPN)	99-02	89	12 750 <b>(28,110)</b>	1.99 <b>(6'6")</b>	2.82 <b>(9'3")</b>	7.17 <b>(23'6")</b>	2.49 <b>(8'2")</b>	8.24 <b>(27'0")</b>	3900 <b>(8600)</b>
313C CR	HGF(JPN)	01-08		12 600 <b>(27,780)</b>	1.99 <b>(6'6")</b>	2.82 <b>(9'3")</b>	7.28 <b>(23'11")</b>	2.49 <b>(8'2")</b>	8.63 <b>(28'4")</b>	3600 <b>(7700)</b>
	WSA(JPN)	02-08		13 900 <b>(30,650)</b>	1.99 <b>(6'6")</b>	2.82 <b>(9'3")</b>	7.48 <b>(24'7")</b>	2.49 <b>(8'2")</b>	7.23 <b>(23'9")</b>	3400 <b>(7250)</b>
313D	KXD(CHN)	12-12	90	13 430	1.99	2.83	7.61	2.49	8.22	4150
	WPK(CHN)	12-13		<b>(29,610)</b>	<b>(6'6")</b>	<b>(9'3")</b>	<b>(25'0")</b>	<b>(8'2")</b>	<b>(27'0")</b>	<b>(8900)</b>
313D SR	LBR(JPN)	08-12	77	14 400 <b>(31,750)</b>	1.99 <b>(6'6")</b>	2.8 <b>(9'3")</b>	7.49 <b>(24'7")</b>	2.49 <b>(8'2")</b>	7.23 <b>(23'9")</b>	3450 <b>(7400)</b>
	(KJA)	02-02	90	14 610 <b>(32,210)</b>	1.99 <b>(6'6")</b>	2.81 <b>(9'3")</b>	7.28 <b>(23'11")</b>	2.59 <b>(8'6")</b>	8.765 <b>(28'9")</b>	1351 <b>(3000)</b>
314C CR	KHB	01-	90	13 500 <b>(29,760)</b>	1.99 <b>(6'6")</b>	2.81 <b>(9'3")</b>	7.28 <b>(23'11")</b>	2.49 <b>(8'2")</b>	8.32 <b>(27'4")</b>	1527 <b>(3400)</b>
	(PCA)	02-02	90	14 810 <b>(32,650)</b>	1.99 <b>(6'6")</b>	2.73 <b>(9'0")</b>	7.41 <b>(24'4")</b>	2.59 <b>(8'6")</b>	8.765 <b>(28'9")</b>	1372 <b>(3000)</b>
314D CR	PDP(OSJ)	08-13	87	14 000	1.99	2.91	7.27	2.49	8.63	4250
	MFK(JPN)	08-12		<b>(30,870)</b>	<b>(6'6")</b>	<b>(9'7")</b>	<b>(23'10")</b>	<b>(8'2")</b>	<b>(28'4")</b>	<b>(9100)</b>
	WLN(OSJ)	10-14								
314D LCR	BYJ(OSJ)	08-13	87	14 100	1.99	2.91	7.27	2.49	8.63	4950
	SBP	08-09		<b>(31,090)</b>	<b>(6'6")</b>	<b>(9'7")</b>	<b>(23'10")</b>	<b>(8'2")</b>	<b>(28'4")</b>	<b>(10,600)</b>
	(SSZ)	10-12								
	TXN	10-12								
	XHR(OSJ)	10-14								

\*When shipped with medium stick and bucket curled under.

\*\*Maximum reach at ground level, one-piece boom, longest stick.

\*\*\*Lift capacity at 4.6 m (15'0") over front, one-piece boom, longest stick.

## Hydraulic Excavators (Track) (cont'd)

Model	Product Ident. No. Prefix COSA (US)	Years Built	Flywheel Horsepower	Approx. Operating Weight kg (lb)	Track Gauge m (ft)	Height* m (ft)	Length* m (ft)	Width m (ft)	Max. Reach** m (ft)	Lift Capacity*** kg (lb)
315	3ZM	95-98	99	15 920 <b>(35,100)</b>	1.99 <b>(6'6")</b>	2.88 <b>(9'5")</b>	8.5 <b>(27'11")</b>	2.49 <b>(8'2")</b>	8.21 <b>(26'11")</b>	5300 <b>(11,700)</b>
	4YM(OSJ)	94-97	99	16 330 <b>(36,000)</b>	1.99 <b>(6'6")</b>	2.88 <b>(9'5")</b>	8.5 <b>(27'11")</b>	2.49 <b>(8'2")</b>	9.14 <b>(30'0")</b>	5290 <b>(11,700)</b>
	6XM(JPN)	94-97	99	15 330 <b>(33,800)</b>	1.99 <b>(6'6")</b>	2.88 <b>(9'5")</b>	8.5 <b>(27'11")</b>	2.49 <b>(8'2")</b>	9.14 <b>(30'0")</b>	—
315 L	6YM(OSJ)	94-97	99	15 920 <b>(35,100)</b>	1.99 <b>(6'6")</b>	2.88 <b>(9'5")</b>	8.5 <b>(27'11")</b>	2.59 <b>(8'6")</b>	8.74 <b>(28'8")</b>	6320 <b>(13,900)</b>
315B	1SW(OSJ)	97-01	99	16 300 <b>(35,940)</b>	1.99 <b>(6'6")</b>	2.88 <b>(9'5")</b>	8.5 <b>(27'11")</b>	2.49 <b>(8'2")</b>	9.14 <b>(30'0")</b>	5500 <b>(12,100)</b>
	2DW(JPN)	97-01	99	15 850 <b>(34,940)</b>	1.99 <b>(6'6")</b>	2.88 <b>(9'5")</b>	8.5 <b>(27'11")</b>	2.49 <b>(8'2")</b>	9.14 <b>(30'0")</b>	—
315B L	5SW	98-	99	16 700 <b>(36,820)</b>	1.995 <b>(6'7")</b>	3.0 <b>(9'10")</b>	8.41 <b>(27'7")</b>	2.49 <b>(8'2")</b>	9.02 <b>(29'7")</b>	6720 <b>(14,800)</b>
	3AW(OSJ) 7RZ(forest) (OSJ) (CFB)	97-01	80/107	16 700 <b>(36,820)</b>	1.99 <b>(6'6")</b>	2.88 <b>(9'5")</b>	8.47 <b>(27'10")</b>	2.59 <b>(8'6")</b>	9.14 <b>(30'0")</b>	6600 <b>(14,600)</b>
315C	(CFB)	01-02	110	16 400 <b>(36,160)</b>	1.99 <b>(6'6")</b>	2.99 <b>(9'10")</b>	8.52 <b>(27'11")</b>	2.59 <b>(8'6")</b>	9.29 <b>(30'6")</b>	1675 <b>(3700)</b>
	CFL	01-	110	16 000 <b>(35,270)</b>	1.99 <b>(6'6")</b>	2.95 <b>(9'8")</b>	8.52 <b>(27'11")</b>	2.49 <b>(8'2")</b>	8.9 <b>(29'2")</b>	1840 <b>(4100)</b>
	AKE	03-07	110	16 399 <b>(36,160)</b>	1.99 <b>(6'6")</b>	2.88 <b>(9'5")</b>	8.5 <b>(27'11")</b>	2.49 <b>(8'2")</b>	9.14 <b>(30'0")</b>	5650 <b>(12,100)</b>
315C L	(CFT)	01-02	110	16 750 <b>(36,930)</b>	1.99 <b>(6'6")</b>	2.99 <b>(9'10")</b>	8.52 <b>(27'11")</b>	2.59 <b>(8'6")</b>	9.29 <b>(30'6")</b>	1719 <b>(3800)</b>
	CJC	03-07	110	16 748 <b>(36,930)</b>	1.99 <b>(6'6")</b>	2.88 <b>(9'5")</b>	8.5 <b>(27'11")</b>	2.59 <b>(8'6")</b>	9.14 <b>(30'0")</b>	6750 <b>(14,450)</b>
	ANF	03	83/111	16 770 <b>(36,970)</b>	1.99 <b>(6'6")</b>	2.76 <b>(9'0")</b>	8.39 <b>(27'6")</b>	2.49 <b>(8'2")</b>	9.09 <b>(29'9")</b>	7110 <b>(15,675)</b>
315D L	CJN(OSJ)	07-12	113	17 280	1.99	3.03	8.54	2.59	9.24	7100
	BYK(JPN)	07-11		<b>(38,100)</b>	<b>(6'6")</b>	<b>(9'9")</b>	<b>(28'0")</b>	<b>(8'6")</b>	<b>(30'3")</b>	<b>(15,100)</b>
	NCM	07-11								
	KBD	07-09								
	(JGS)	10-11								
	TLE	09-11								
317	4MM	95-98	99	17 260 <b>(38,050)</b>	2.15 <b>(7'1")</b>	2.88 <b>(9'5")</b>	8.5 <b>(27'11")</b>	2.75 <b>(9'0")</b>	8.62 <b>(28'3")</b>	4210 <b>(9300)</b>
	9WW	98-	81/109	17 300 <b>(38,146)</b>	2.2 <b>(7'3")</b>	3.04 <b>(9'10")</b>	8.41 <b>(27'6")</b>	2.8 <b>(9'2")</b>	9.1 <b>(29'8")</b>	7100 <b>(15,655)</b>
317 N	9SR	96-98	99	17 220 <b>(37,960)</b>	1.99 <b>(6'6")</b>	2.88 <b>(9'5")</b>	8.5 <b>(27'11")</b>	2.75 <b>(9'0")</b>	8.62 <b>(28'3")</b>	6450 <b>(14,200)</b>
317B LN	6DZ	98-	81/110	17 300 <b>(38,146)</b>	1.995 <b>(6'5")</b>	3.04 <b>(9'10")</b>	8.41 <b>(27'6")</b>	2.49 <b>(8'2")</b>	9.1 <b>(29'8")</b>	7100 <b>(15,655)</b>

\*When shipped with medium stick and bucket curled under.

\*\*Maximum reach at ground level, one-piece boom, longest stick.

\*\*\*Lift capacity at 4.6 m (15'0") over front, one-piece boom, longest stick.

## Hydraulic Excavators (Track) (cont'd)

Model	Product Ident. No. Prefix COSA (US)	Years Built	Flywheel Horsepower	Approx. Operating Weight kg (lb)	Track Gauge m (ft)	Height* m (ft)	Length* m (ft)	Width m (ft)	Max. Reach** m (ft)	Lift Capacity*** kg (lb)
318B L	9VW	98-	86/115	17 700 <b>(39,020)</b>	2.2 <b>(7'3")</b>	3.02 <b>(9'11")</b>	8.67 <b>(28'5")</b>	2.8 <b>(9'2")</b>	8.94 <b>(29'4")</b>	8440 <b>(18,600)</b>
	3LR(OSJ)	99-02	86/115	18 390 <b>(40,540)</b>	2.2 <b>(7'3")</b>	3.05 <b>(10'0")</b>	8.72 <b>(28'7")</b>	2.8 <b>(9'2")</b>	9.77 <b>(32'0")</b>	7650 <b>(16,900)</b>
	ADC	99-	86/115	18 500 <b>(40,792)</b>	2.2 <b>(7'3")</b>	3.04 <b>(9'10")</b>	8.69 <b>(28'6")</b>	2.8 <b>(9'2")</b>	9.6 <b>(31'6")</b>	7600 <b>(16,760)</b>
	(3LR)	01-02	86/115	18 360 <b>(40,480)</b>	2.2 <b>(7'3")</b>	2.83 <b>(9'3")</b>	8.69 <b>(28'6")</b>	2.8 <b>(9'2")</b>	9.78 <b>(32'1")</b>	2200 <b>(4900)</b>
318B LN	6DZ	98-	86/115	17 160 <b>(37,830)</b>	1.995 <b>(6'7")</b>	3.02 <b>(9'11")</b>	8.67 <b>(28'5")</b>	2.495 <b>(8'2")</b>	8.94 <b>(29'4")</b>	7590 <b>(16,700)</b>
	7KZ(OSJ)	99-02	86/115	18 260 <b>(40,260)</b>	2.2 <b>(7'3")</b>	3.05 <b>(10'0")</b>	8.72 <b>(28'7")</b>	2.59 <b>(8'6")</b>	9.77 <b>(32'1")</b>	7600 <b>(16,800)</b>
	AEJ	99-	86/115	18 500 <b>(40,792)</b>	1.995 <b>(6'7")</b>	3.04 <b>(9'10")</b>	8.69 <b>(28'6")</b>	2.49 <b>(8'2")</b>	9.6 <b>(31'6")</b>	7580 <b>(16,710)</b>
	(7KZ)	01-02	86/115	17 990 <b>(39,660)</b>	1.995 <b>(6'7")</b>	3.05 <b>(10'0")</b>	8.72 <b>(28'7")</b>	2.49 <b>(8'2")</b>	9.78 <b>(32'1")</b>	2200 <b>(4900)</b>
318C	BTG	03	94/127	19 560 <b>(43,120)</b>	2.2 <b>(7'2")</b>	2.9 <b>(9'9")</b>	8.9 <b>(29'2")</b>	2.8 <b>(9'2")</b>	9.66 <b>(31'8")</b>	7850 <b>(17,305)</b>
318C L	DAH(MDY)	02-07	94/127	20 160 <b>(44,445)</b>	2.2 <b>(7'2")</b>	2.9 <b>(9'9")</b>	8.9 <b>(29'2")</b>	2.8 <b>(9'2")</b>	9.66 <b>(31'8")</b>	8950 <b>(19,730)</b>
318C N	FAA(GPA)	02-07	94/127	19 280 <b>(42,505)</b>	1.99 <b>(6'6")</b>	2.9 <b>(9'9")</b>	8.9 <b>(29'2")</b>	2.49 <b>(8'2")</b>	9.66 <b>(31'8")</b>	7730 <b>(17,040)</b>
318D L	ZKJ(CHN)	12-13	113	17 620 <b>(38,850)</b>	1.99 <b>(6'6")</b>	3.03 <b>(9'9")</b>	8.54 <b>(28'0")</b>	2.59 <b>(8'6")</b>	8.96 <b>(29'5")</b>	6850 <b>(14,700)</b>
319C LN	KGL	04	94/127	20 080 <b>(44,269)</b>	1.99 <b>(6'6")</b>	2.9 <b>(9'9")</b>	8.9 <b>(29'2")</b>	2.49 <b>(9'2")</b>	9.66 <b>(31'8")</b>	7730 <b>(17,040)</b>
319D L	EAW(OSJ)	08-13	121	19 460 <b>(42,910)</b>	2.2 <b>(7'3")</b>	3.15 <b>(10'4")</b>	8.82 <b>(28'11")</b>	2.8 <b>(9'2")</b>	9.82 <b>(32'3")</b>	9150 <b>(19,700)</b>
	BZH	07-09								
	(ZCA)	10-12								
	ZGZ	09-11								
319D LN	AYF	11-12								
	KRM(OSJ)	11-13								
	FMH(OSJ)	08-13	121	19 170 <b>(42,270)</b>	1.99 <b>(6'6")</b>	3.15 <b>(10'4")</b>	8.82 <b>(28'11")</b>	2.49 <b>(8'2")</b>	9.82 <b>(32'3")</b>	9150 <b>(19,700)</b>
	DAY	08-09								
	(KFM)	10-12								
WBJ	09-11									
RJP	11-12									

\*When shipped with medium stick and bucket curled under.

\*\*Maximum reach at ground level, one-piece boom, longest stick.

\*\*\*Lift capacity at 4.6 m (15'0") over front, one-piece boom, longest stick.

Hydraulic Excavators (Track) (cont'd)

Model	Product Ident. No. Prefix COSA (US)	Years Built	Flywheel Horsepower	Approx. Operating Weight kg (lb)	Track Gauge m (ft)	Height* m (ft)	Length* m (ft)	Width m (ft)	Max. Reach** m (ft)	Lift Capacity*** kg (lb)
320	7WK(OSJ) 2DL(OSJ) 8LG(OSJ) 7GJ(JPN) 3XM(JPN) 4ZJ(GOS)	91-96	128	19 120 <b>(42,150)</b>	2.2 <b>(7'3")</b>	2.93 <b>(9'7")</b>	9.37 <b>(30'9)</b>	2.8 <b>(9'2")</b>	10.63 <b>(34'9")</b>	6200 <b>(17,700)</b>
320 L	1TL(OSJ) 9KK(OSJ) 8HJ(JPN) 4JM(JPN) 3XK(GOS)	91-96	128	20 370 <b>(44,910)</b>	2.38 <b>(7'10")</b>	2.93 <b>(9'7")</b>	9.37 <b>(30'9")</b>	3.18 <b>(10'5")</b>	10.63 <b>(34'9")</b>	8150 <b>(17,600)</b>
320 N	1XM(OSJ) 9WG(GOS)	94-96	128	20 050 <b>(44,150)</b>	1.90 <b>(6'6")</b>	2.93 <b>(9'7")</b>	9.37 <b>(30'9")</b>	2.59 <b>(8'6")</b>	10.63 <b>(34'9")</b>	8150 <b>(17,600)</b>
320 S	6KM									
320B	3MR 5BR 1XS	96-00	128	19 400 <b>(42,770)</b>	2.2 <b>(7'2.6")</b>	3.01 <b>(9'10.5")</b>	9.46 <b>(31'4")</b>	2.8 <b>(9'2.2")</b>	10.77 <b>(35'4")</b>	8600 <b>(19,000)</b>
320B L	4MR 6CR 7JR	96-00	128	20 720 <b>(45,680)</b>	2.38 <b>(7'9.7")</b>	3.01 <b>(9'10.5")</b>	9.46 <b>(31'4")</b>	3.18 <b>(10'5.2")</b>	10.77 <b>(35'4")</b>	9200 <b>(20,300)</b>
320B N	4NR 2AS	96-00	128	19 930 <b>(43,940)</b>	2.2 <b>(7'2.6")</b>	3.01 <b>(9'10.5")</b>	9.46 <b>(31'4")</b>	2.5 <b>(8'2.4")</b>	10.77 <b>(35'4")</b>	9100 <b>(20,100)</b>
320B LN	3YZ	96-00	128							
320C	MAB	03-06	103	20 870 <b>(46,010)</b>	2.2 <b>(7'3")</b>	3.01 <b>(9'11")</b>	9.39 <b>(30'10")</b>	2.8 <b>(9'2")</b>	9.71 <b>(31'10")</b>	8810 <b>(19,423)</b>
320C L	ANB PAB TBR SAH	99-07	103	21 415 <b>(47,212)</b>	2.38 <b>(7'10")</b>	3.01 <b>(9'11")</b>	9.39 <b>(30'10")</b>	2.98 <b>(9'9")</b>	9.71 <b>(31'10")</b>	9550 <b>(21,054)</b>
320C U	MAC	03-05	103	22 300 <b>(49,163)</b>	2.2 <b>(7'3")</b>	3.01 <b>(9'11")</b>	8.73 <b>(28'8")</b>	2.8 <b>(9'2")</b>	9.86 <b>(32'4")</b>	9300 <b>(20,503)</b>
320C LU	PAC	02-07	103	23 000 <b>(50,706)</b>	2.38 <b>(7'10")</b>	3.01 <b>(9'11")</b>	8.92 <b>(29'3")</b>	2.98 <b>(9'9")</b>	9.86 <b>(32'4")</b>	9600 <b>(21,164)</b>
320D	AZR CXY EBT BWZ FAL A6F BZP JFZ SNS KLM KTF PCM KHN MZD	05-15	103	21 000 <b>(46,300)</b>	2.2 <b>(7'3")</b>	3.03 <b>(9'10")</b>	9.46 <b>(31'0")</b>	2.8 <b>(9'2")</b>	10 <b>(32'10")</b>	9000† <b>(19,800)</b>

\*When shipped with medium stick and bucket curled under.  
 \*\*Maximum reach at ground level, one-piece boom, longest stick.  
 \*\*\*Lift capacity at 4.6 m (15'0") over front, one-piece boom, longest stick.  
 †Without bucket.

## Hydraulic Excavators (Track) (cont'd)

Model	Product Ident. No. Prefix COSA (US)	Years Built	Flywheel Horsepower	Approx. Operating Weight kg (lb)	Track Gauge m (ft)	Height* m (ft)	Length* m (ft)	Width m (ft)	Max. Reach** m (ft)	Lift Capacity*** kg (lb)
320D L	BWP DHK MDE FNA DFB KGF A8F MGG PHX A9F WJN TDH SPN GDP KZF	05-15	103	21 900 <b>(48,300)</b>	2.38 <b>(7'10")</b>	3.03 <b>(9'10")</b>	9.46 <b>(31'0")</b>	2.98 <b>(9'9")</b>	10.0 <b>(32'10")</b>	10 250† <b>(22,600)</b>
320D LN	KAF WBN PCX	06-11	103	21 200 <b>(46,700)</b>	2.0 <b>(6'7")</b>	3.03 <b>(9'10")</b>	9.49 <b>(31'2")</b>	2.5 <b>(8'2")</b>	9.78 <b>(32'1")</b>	N/A
320D RR	AMR RBL GKL GMX YDS WFD	05-15	103	22 700 <b>(50,045)</b>	2.2 <b>(7'3")</b>	3.01 <b>(9'11")</b>	8.77 <b>(28'9")</b>	2.8 <b>(9'2")</b>	9.78 <b>(32'1")</b>	9050 <b>(19,952)</b>
320D LRR	CWN SCW FXK HJC EBY TAE XCK DHE ZGB EJT	05-15	103	23 300 <b>(51,368)</b>	2.38 <b>(7'10")</b>	3.01 <b>(9'11")</b>	8.96 <b>(29'5")</b>	2.98 <b>(9'9")</b>	9.78 <b>(32'1")</b>	10 600 <b>(23,369)</b>
320E	SHX	13-14	107	20 900 <b>(46,100)</b>	2.2 <b>(7'3")</b>	3.15 <b>(10'3")</b>	9.54 <b>(31'4")</b>	2.8 <b>(9'9")</b>	9.86 <b>(32'4")</b>	9450† <b>(20,350)</b>
320E L	WBK TNJ NAZ	10-16	114	21 700 <b>(47,800)</b>	2.38 <b>(7'10")</b>	3.15 <b>(10'3")</b>	9.54 <b>(31'4")</b>	2.98 <b>(9'9")</b>	9.86 <b>(32'4")</b>	11 650† <b>(25,700)</b>
		10-16	107	21 700 <b>(47,800)</b>	2.38 <b>(7'10")</b>	3.15 <b>(10'3")</b>	9.54 <b>(31'4")</b>	2.98 <b>(9'9")</b>	9.86 <b>(32'4")</b>	11 650† <b>(25,700)</b>
320E LN	DFG	11-14	107	22 500 <b>(49,500)</b>	2.0 <b>(6'7")</b>	3.15 <b>(10'3")</b>	9.57 <b>(31'5")</b>	2.54 <b>(8'4")</b>	9.85 <b>(32'4")</b>	10 600† <b>(22,900)</b>
320E LRR	PNL	11-15	114	23 800 <b>(52,470)</b>	2.38 <b>(7'10")</b>	3.15 <b>(10'3")</b>	8.97 <b>(29'5")</b>	2.98 <b>(9'9")</b>	9.86 <b>(32'4")</b>	11 550† <b>(24,800)</b>

\*When shipped with medium stick and bucket curled under.

\*\*Maximum reach at ground level, one-piece boom, longest stick.

\*\*\*Lift capacity at 4.6 m (15'0") over front, one-piece boom, longest stick.

†Without bucket.



## Hydraulic Excavators (Track) (cont'd)

Model	Product Ident. No. Prefix COSA (US)	Years Built	Flywheel Horsepower	Approx. Operating Weight kg (lb)	Track Gauge m (ft)	Height* m (ft)	Length* m (ft)	Width m (ft)	Max. Reach** m (ft)	Lift Capacity*** kg (lb)
321B CR	AKG(JPN)	98-01	128	19 400 <b>(42,770)</b>	2.2 <b>(7'3")</b>	3.1 <b>(10'2")</b>	8.6 <b>(28'3")</b>	2.98 <b>(9'9")</b>	9.68 <b>(31'9")</b>	8250 <b>(18,200)</b>
321B LCR	9CZ(JPN)	98-01	128	22 500 <b>(49,600)</b>	2.38 <b>(7'10")</b>	3.1 <b>(10'2")</b>	8.8 <b>(28'11")</b>	2.98 <b>(9'9")</b>	9.68 <b>(31'9")</b>	10 300 <b>(22,700)</b>
	KGA(OSJ)	02-02	128	23 100 <b>(50,930)</b>	2.38 <b>(7'10")</b>	3.1 <b>(10'2")</b>	8.8 <b>(28'11")</b>	2.98 <b>(9'9")</b>	9.68 <b>(31'9")</b>	10 300 <b>(22,700)</b>
321C CR	DAX	03-06	103	22 830 <b>(50,332)</b>	2.2 <b>(7'3")</b>	3.17 <b>(10'5")</b>	8.64 <b>(28'4")</b>	2.8 <b>(9'2")</b>	9.69 <b>(31'9")</b>	9050 <b>(19,952)</b>
321C LCR	KBB MCF KCR	02-07	103	24 000 <b>(52,911)</b>	2.38 <b>(7'10")</b>	3.17 <b>(10'5")</b>	8.83 <b>(29'0")</b>	2.98 <b>(9'9")</b>	9.69 <b>(31'9")</b>	11 000 <b>(24,251)</b>
321D CR	JCX	07-14	103	23 000 <b>(50,700)</b>	2.200 <b>(7'3")</b>	3.03 <b>(9'11")</b>	8.69 <b>(28'6")</b>	2.8 <b>(9'2")</b>	9.71 <b>(31'10")</b>	N/A
321D L CR	KBH KBZ MDT MPG NAS PBD TXA	07-15	103	23 780 <b>(52,400)</b>	2.38 <b>(7'10")</b>	3.03 <b>(9'11")</b>	8.83 <b>(29'0")</b>	2.98 <b>(9'9")</b>	9.71 <b>(31'10")</b>	11 150 <b>(24,000)</b>
322*	7WL(OSJ) 7WL(JPN)	93-96	153	22 650 <b>(50,000)</b>	2.39 <b>(7'10")</b>	3.12 <b>(10'3")</b>	9.95 <b>(32'8")</b>	2.99 <b>(9'10")</b>	10.47 <b>(34'4")</b>	10 400 <b>(22,500)</b>
322B	8MR 3NR	96-01 96-00	153	22 760 <b>(50,180)</b>	2.39 <b>(7'10")</b>	3.28 <b>(10'9")</b>	10.0 <b>(32'10")</b>	2.99 <b>(9'10")</b>	10.47 <b>(34'4")</b>	10 650 <b>(23,500)</b>
322 L*	8CL(OSJ) 8CL(JPN)	93-96	153	23 950 <b>(52,800)</b>	2.59 <b>(8'6")</b>	3.12 <b>(10'3")</b>	9.95 <b>(32'8")</b>	3.39 <b>(11'1")</b>	10.47 <b>(34'4")</b>	10 400 <b>(22,500)</b>
322B L	8NR 5CR	96-01 96-00	153	23 990 <b>(52,890)</b>	2.59 <b>(8'6")</b>	3.28 <b>(10'9")</b>	10.0 <b>(32'10")</b>	3.39 <b>(11'1")</b>	10.47 <b>(34'4")</b>	11 600 <b>(25,600)</b>
322C	DAA	03-05	121	23 000 <b>(50,706)</b>	2.39 <b>(7'10")</b>	3.12 <b>(10'3")</b>	9.96 <b>(32'8")</b>	2.99 <b>(9'10")</b>	10.01 <b>(32'10")</b>	10 750 <b>(23,700)</b>
322C L	BGR BFK FED	01-02 02-06 02-05	165 121	24 200 <b>(53,400)</b> 24 200 <b>(53,352)</b>	2.59 <b>(8'6")</b> 2.59 <b>(8'6")</b>	3.12 <b>(10'3")</b> 3.12 <b>(10'3")</b>	9.96 <b>(32'8")</b> 9.96 <b>(32'8")</b>	3.39 <b>(11'1")</b> 3.19 <b>(10'6")</b>	10.47 <b>(34'4")</b> 10.01 <b>(32'10")</b>	11 500 <b>(24,900)</b> 12 000 <b>(26,455)</b>

\*When shipped with medium stick and bucket curled under.

\*\*Maximum reach at ground level, one-piece boom, longest stick.

\*\*\*Lift capacity at 4.6 m (15'0") over front, one-piece boom, longest stick.

## Hydraulic Excavators (Track) (cont'd)

Model	Product Ident. No. Prefix COSA (US)	Years Built	Flywheel Horsepower	Approx. Operating Weight kg (lb)	Track Gauge m (ft)	Height* m (ft)	Length* m (ft)	Width m (ft)	Max. Reach** m (ft)	Lift Capacity*** kg (lb)
323D	WNE	10-11	110	22 200 <b>(48,900)</b>	2.2 <b>(7'3")</b>	3.12 <b>(10'3")</b>	9.46 <b>(31'0")</b>	2.8 <b>(9'2")</b>	9.83 <b>(32'3")</b>	N/A
323D L	PBM SDC BYM WGC JLG LFL PBE YSD NDE ZMF GTF NTF NZF	06-11	110	23 200 <b>(51,100)</b>	2.38 <b>(7'10")</b>	3.12 <b>(10'3")</b>	9.46 <b>(31'0")</b>	2.98 <b>(9'9")</b>	9.83 <b>(32'3")</b>	10 330 <b>(22,800)</b>
323D LN	CYD RAC CWG	05-11	110	23 200 <b>(50,700)</b>	2.0 <b>(6'7")</b>	3.12 <b>(10'3")</b>	9.46 <b>(31'0")</b>	2.5 <b>(8'2")</b>	9.83 <b>(32'3")</b>	10 330 <b>(22,800)</b>
323D S	DKW	05-07	103	22 500 <b>(49,600)</b>	1.9 <b>(6'3")</b>	3.1 <b>(10'2")</b>	9.46 <b>(31'0")</b>	2.5 <b>(8'2")</b>	9.44 <b>(31'0")</b>	N/A
323D SA	NES SED	06-11	110	23 500 <b>(51,800)</b>	1.9 <b>(6'3")</b>	3.12 <b>(10'3")</b>	9.5 <b>(31'2")</b>	2.5 <b>(8'2")</b>	9.98 <b>(32'9")</b>	10 360 <b>(22,800)</b>
323E L	RAP	10-16	114	22 600 <b>(49,800)</b>	2.38 <b>(7'10")</b>	3.15 <b>(10'3")</b>	9.54 <b>(31'4")</b>	2.98 <b>(9'9")</b>	9.86 <b>(32'4")</b>	11 450† <b>(24,800)</b>
323E LN	TDW	10-16	114	23 300 <b>(51,300)</b>	2.0 <b>(6'7")</b>	3.15 <b>(10'3")</b>	9.56 <b>(31'4")</b>	2.54 <b>(8'4")</b>	9.85 <b>(32'4")</b>	11 450† <b>(24,800)</b>
323E SA	YRP	10-16	114	24 300 <b>(53,500)</b>	1.9 <b>(6'3")</b>	3.23 <b>(10'7")</b>	9.57 <b>(31'5")</b>	2.54 <b>(8'2")</b>	9.84 <b>(32'3")</b>	11 300† <b>(24,450)</b>
324D	MND CJX JZR AWN ECH	06-14	140	24 550 <b>(54,100)</b>	2.39 <b>(7'10")</b>	3.43 <b>(11'3")</b>	10.05 <b>(34'5")</b>	2.99 <b>(9'10")</b>	10.55 <b>(34'7")</b>	N/A
324D L	JAT SYM PYT GPK DFP TSN T2D LKN BTK JYG LAB BYE	06-14	140	25 870 <b>(57,000)</b>	2.59 <b>(8'6")</b>	3.43 <b>(11'3")</b>	10.05 <b>(34'5")</b>	3.39 <b>(11'1")</b>	10.55 <b>(34'7")</b>	11 400 <b>(25,100)</b>
324D LN	NPC TRH EJC	06-11	140	25 300 <b>(55,800)</b>	2.39 <b>(7'10")</b>	3.17 <b>(10'5")</b>	10.06 <b>(33'0")</b>	2.99 <b>(9'10")</b>	10.05 <b>(34'5")</b>	13 970 <b>(30,800)</b>

\*When shipped with medium stick and bucket curled under.

\*\*Maximum reach at ground level, one-piece boom, longest stick.

\*\*\*Lift capacity at 4.6 m (15'0") over front, one-piece boom, longest stick.

†Without bucket.

## Hydraulic Excavators (Track) (cont'd)

Model	Product Ident. No. Prefix COSA (US)	Years Built	Flywheel Horsepower	Approx. Operating Weight kg (lb)	Track Gauge m (ft)	Height* m (ft)	Length* m (ft)	Width m (ft)	Max. Reach** m (ft)	Lift Capacity*** kg (lb)
324E	JCZ	11-16	142	24 750 <b>(54,600)</b>	2.39 <b>(7'10")</b>	3.22 <b>(10'7")</b>	10.06 <b>(33'0")</b>	2.99 <b>(9'10")</b>	10.11 <b>(33'2")</b>	12 350† <b>(26,450)</b>
324E L	KTE	10-16	145	26 310 <b>(58,000)</b>	2.59 <b>(8'6")</b>	3.22 <b>(10'7")</b>	10.06 <b>(33'0")</b>	3.38 <b>(11'1")</b>	10.11 <b>(33'2")</b>	15 350† <b>(32,900)</b>
324E LN	PNW TLF LDG	10-15	145	25 130 <b>(55,400)</b>	2.39 <b>(7'10")</b>	3.41 <b>(11'2")</b>	10.1 <b>(33'2")</b>	2.99 <b>(9'10")</b>	10.11 <b>(33'2")</b>	15 100† <b>(32,300)</b>
325*	5WK(OSJ)	91-95	168	25 520 <b>(56,270)</b>	2.39 <b>(7'10")</b>	3.24 <b>(10'8")</b>	10.27 <b>(33'8")</b>	2.99 <b>(9'10")</b>	11.50 <b>(37'7")</b>	11 100 <b>(24,000)</b>
	8NL(OSJ)		168	25 520 <b>(56,270)</b>	2.39 <b>(7'10")</b>	3.24 <b>(10'8")</b>	10.27 <b>(33'8")</b>	2.99 <b>(9'10")</b>	11.50 <b>(37'7")</b>	11 000 <b>(24,000)</b>
	8JG(JPN)	91-95	168	25 520 <b>(56,270)</b>	2.39 <b>(7'10")</b>	3.24 <b>(10'8")</b>	10.27 <b>(33'8")</b>	2.99 <b>(9'10")</b>	11.50 <b>(37'7")</b>	11 000 <b>(24,000)</b>
325 L*	5WK(JPN)	91-95	168	27 010 <b>(59,560)</b>	2.59 <b>(8'6")</b>	3.24 <b>(10'8")</b>	10.27 <b>(33'8")</b>	3.39 <b>(11'1")</b>	11.50 <b>(37'7")</b>	11 650 <b>(25,150)</b>
	6KK(OSJ)	91-95	168	27 010 <b>(59,560)</b>	2.59 <b>(8'6")</b>	3.24 <b>(10'8")</b>	10.27 <b>(33'8")</b>	3.39 <b>(11'1")</b>	11.50 <b>(37'7")</b>	11 650 <b>(25,150)</b>
	9KL(OSJ)	91-95	168	27 010 <b>(59,560)</b>	2.59 <b>(8'6")</b>	3.24 <b>(10'8")</b>	10.27 <b>(33'8")</b>	3.39 <b>(11'1")</b>	11.50 <b>(37'7")</b>	11 650 <b>(25,150)</b>
	7CJ(JPN)	91-95	168	27 010 <b>(59,560)</b>	2.59 <b>(8'6")</b>	3.24 <b>(10'8")</b>	10.27 <b>(33'8")</b>	3.39 <b>(11'1")</b>	11.50 <b>(37'7")</b>	11 650 <b>(25,150)</b>
325B L	6KK(JPN)	96-01	168	28 890 <b>(63,690)</b>	2.59 <b>(8'6")</b>	3.21 <b>(10'6")</b>	10.35 <b>(33'11")</b>	3.39 <b>(11'1")</b>	10.57 <b>(34'8")</b>	15 460 <b>(34,080)</b>
325B LN	6DN(GOS)	96-01	168	27 670 <b>(61,000)</b>	2.39 <b>(7'10")</b>	3.21 <b>(10'6")</b>	10.35 <b>(33'11")</b>	2.99 <b>(9'10")</b>	10.57 <b>(34'8")</b>	15 030 <b>(33,140)</b>
325C L	8FN(GOS)	96-01	168	27 670 <b>(61,000)</b>	2.39 <b>(7'10")</b>	3.21 <b>(10'6")</b>	10.35 <b>(33'11")</b>	2.99 <b>(9'10")</b>	10.57 <b>(34'8")</b>	15 030 <b>(33,140)</b>
325D L	CBR	01-06	188	28 600 <b>(63,100)</b>	2.59 <b>(8'6")</b>	3.26 <b>(10'8")</b>	10.34 <b>(33'11")</b>	3.39 <b>(11'1")</b>	10.51 <b>(34'6")</b>	15 600 <b>(33,750)</b>
	CSJ	06-08	204	29 240 <b>(64,460)</b>	2.59 <b>(8'6")</b>	3.04 <b>(10'0")</b>	10.42 <b>(34'2")</b>	3.39 <b>(11'1")</b>	11.15 <b>(36'7")</b>	15 450 <b>(33,400)</b>
326D L	A3R	06-08	204	29 240 <b>(64,460)</b>	2.59 <b>(8'6")</b>	3.04 <b>(10'0")</b>	10.42 <b>(34'2")</b>	3.39 <b>(11'1")</b>	11.15 <b>(36'7")</b>	15 450 <b>(33,400)</b>
326D L	PJM	12-14	140	25 560 <b>(56,400)</b>	2.59 <b>(8'6")</b>	3.17 <b>(10'5")</b>	10.06 <b>(33'0")</b>	3.39 <b>(11'1")</b>	10.03 <b>(32'11")</b>	13 900 <b>(30,600)</b>
328D L CR	RMX	06-15	152	36 200 <b>(79,800)</b>	2.59 <b>(8'6")</b>	3.37 <b>(11'1")</b>	9.82 <b>(32'3")</b>	3.44 <b>(11'3")</b>	10.56 <b>(34'8")</b>	12 300 <b>(28,000)</b>
	JTC			36 200 <b>(79,800)</b>	2.59 <b>(8'6")</b>	3.37 <b>(11'1")</b>	9.82 <b>(32'3")</b>	3.44 <b>(11'3")</b>	10.56 <b>(34'8")</b>	12 300 <b>(28,000)</b>
	MKR			36 200 <b>(79,800)</b>	2.59 <b>(8'6")</b>	3.37 <b>(11'1")</b>	9.82 <b>(32'3")</b>	3.44 <b>(11'3")</b>	10.56 <b>(34'8")</b>	12 300 <b>(28,000)</b>
	GTN			36 200 <b>(79,800)</b>	2.59 <b>(8'6")</b>	3.37 <b>(11'1")</b>	9.82 <b>(32'3")</b>	3.44 <b>(11'3")</b>	10.56 <b>(34'8")</b>	12 300 <b>(28,000)</b>
	SWF			36 200 <b>(79,800)</b>	2.59 <b>(8'6")</b>	3.37 <b>(11'1")</b>	9.82 <b>(32'3")</b>	3.44 <b>(11'3")</b>	10.56 <b>(34'8")</b>	12 300 <b>(28,000)</b>
	BYH			36 200 <b>(79,800)</b>	2.59 <b>(8'6")</b>	3.37 <b>(11'1")</b>	9.82 <b>(32'3")</b>	3.44 <b>(11'3")</b>	10.56 <b>(34'8")</b>	12 300 <b>(28,000)</b>

\*When shipped with medium stick and bucket curled under.

\*\*Maximum reach at ground level, one-piece boom, longest stick.

\*\*\*Lift capacity at 4.6 m (15'0") over front, one-piece boom, longest stick.

†Without bucket.

## Hydraulic Excavators (Track) (cont'd)

Model	Product Ident. No. Prefix COSA (US)	Years Built	Flywheel Horsepower	Approx. Operating Weight kg (lb)	Track Gauge m (ft)	Height* m (ft)	Length* m (ft)	Width m (ft)	Max. Reach** m (ft)	Lift Capacity*** kg (lb)
329D	BBF	08-14	158	28 010	2.39	3.33	10.36	2.99	10.72	13 750
	WDK			<b>(61,620)</b>	<b>(7'10")</b>	<b>(10'11")</b>	<b>(34'0")</b>	<b>(9'10")</b>	<b>(35'2")</b>	<b>(29,450)</b>
	BYS									
	DTZ									
329D L	TAY	08-15	158	29 970	2.59	3.33	10.36	3.39	10.72	16 200
	MNB			<b>(65,920)</b>	<b>(8'6")</b>	<b>(10'11")</b>	<b>(34'0")</b>	<b>(11'1")</b>	<b>(35'2")</b>	<b>(35,050)</b>
	DJF									
	JHJ									
	BFC									
	LFW									
	RSK									
	TPM									
	J9D									
	J8D									
	L5G									
	L5H									
	TFW									
	XDB									
	CZF									
	WLT									
	TZL									
329D LN	SCY	08-11	152	28 860	2.39	3.18	10.41	2.99	10.6	13 050
	EBM			<b>(63,600)</b>	<b>(7'10")</b>	<b>(10'5")</b>	<b>(34'2")</b>	<b>(9'10")</b>	<b>(34'9")</b>	<b>(28,800)</b>
329E	PTY	10-15	170	27 700	2.39	3.37	10.39	2.99	10.68	14 300†
				<b>(61,100)</b>	<b>(7'10")</b>	<b>(11'1")</b>	<b>(34'1")</b>	<b>(9'10")</b>	<b>(35'0")</b>	<b>(30,650)</b>
329E L	RDX	10-16	170	29 060	2.59	3.37	10.39	3.39	10.68	18 150†
	WJK			<b>(64,100)</b>	<b>(8'6")</b>	<b>(11'1")</b>	<b>(34'1")</b>	<b>(11'1")</b>	<b>(35'0")</b>	<b>(3,300)</b>
	ZCD									
	PLW									
	TST									
329E LN	RLD	10-15	170	28 720	2.39	3.37	10.39	2.99	10.68	18 150†
				<b>(63,300)</b>	<b>(7'10")</b>	<b>(11'1")</b>	<b>(34'1")</b>	<b>(9'10")</b>	<b>(35'0")</b>	<b>(39,300)</b>

\*When shipped with medium stick and bucket curled under.

\*\*Maximum reach at ground level, one-piece boom, longest stick.

\*\*\*Lift capacity at 4.6 m (15'0") over front, one-piece boom, longest stick.

†Without bucket.

## Hydraulic Excavators (Track) (cont'd)

Model	Product Ident. No. Prefix COSA (US)	Years Built	Flywheel Horsepower	Approx. Operating Weight kg (lb)	Track Gauge m (ft)	Height* m (ft)	Length* m (ft)	Width m (ft)	Max. Reach** m (ft)	Lift Capacity*** kg (lb)
330	2ZM	92-95	222	32 100 <b>(70,600)</b>	2.59 <b>(8'6")</b>	3.29 <b>(10'10")</b>	11.01 <b>(36'1")</b>	3.19 <b>(10'6")</b>	12.37 <b>(40'6")</b>	14 600 <b>(31,500)</b>
	6ZK									
	8RL									
	9NG									
	9PG									
	9WJ									
330 L	2EL	92-95	222	33 500 <b>(73,700)</b>	2.59 <b>(8'6")</b>	3.29 <b>(10'10")</b>	11.01 <b>(36'1")</b>	3.34 <b>(10'11")</b>	12.43 <b>(40'9")</b>	14 600 <b>(31,500)</b>
	5YM									
	6SK									
	6WJ									
	8FK									
	9ML									
330 LN	8CK	92-95	222	32 740 <b>(72,030)</b>	2.39 <b>(7'10")</b>	3.29 <b>(10'10")</b>	11.01 <b>(36'1")</b>	2.99 <b>(9'10")</b>	12.37 <b>(40'6")</b>	14 600 <b>(31,500)</b>
330B	2RR	96-01	222	32 500 <b>(71,650)</b>	2.59 <b>(8'6")</b>	3.29 <b>(10'10")</b>	11.06 <b>(36'3")</b>	3.19 <b>(10'6")</b>	11.62 <b>(38'1")</b>	16 450 <b>(35,200)</b>
	4YW									
	5EZ									
	8SR									
	9HN									
330B L	1JS	96-01	222	33 800 <b>(74,520)</b>	2.59 <b>(8'6")</b>	3.29 <b>(10'10")</b>	11.06 <b>(36'3")</b>	3.34 <b>(10'11")</b>	11.69 <b>(38'4")</b>	17 000 <b>(36,750)</b>
	1KS									
	3YR									
	3ZZ									
	4RS									
	5LS									
	6DR									
	8TR									
330B LN	5LR	96-01	222	33 200 <b>(73,190)</b>	2.39 <b>(7'10")</b>	3.29 <b>(10'10")</b>	11.06 <b>(36'3")</b>	2.99 <b>(9'10")</b>	11.62 <b>(38'1")</b>	16 950 <b>(36,600)</b>
330C	BTM	01-06	247	33 300 <b>(73,410)</b>	2.59 <b>(8'6")</b>	3.35 <b>(11')</b>	11.14 <b>(36'7")</b>	3.19 <b>(10'6")</b>	11.64 <b>(38'2")</b>	16 900 <b>(36,550)</b>
	GAG									
	HAA									
	JCD									
	JNK									
	MCA									
	MKM									
	RBH									
330C L	CAP	01-06	247	34 800 <b>(76,720)</b>	2.59 <b>(8'6")</b>	3.35 <b>(11')</b>	11.14 <b>(36'7")</b>	3.34 <b>(10'11")</b>	11.64 <b>(38'2")</b>	16 900 <b>(36,550)</b>
	CYA									
	DKY									
	GKX									
	JAB									
	KDD									
330C LN	CGZ	01-06	247	34 400 <b>(75,840)</b>	2.39 <b>(7'10")</b>	3.35 <b>(11')</b>	11.14 <b>(36'7")</b>	2.99 <b>(9'10")</b>	11.64 <b>(38'2")</b>	16 900 <b>(36,550)</b>

\*When shipped with medium stick and bucket curled under.

\*\*Maximum reach at ground level, one-piece boom, longest stick.

\*\*\*Lift capacity at 4.6 m (15'0") over front, one-piece boom, longest stick.

## Hydraulic Excavators (Track) (cont'd)

Model	Product Ident. No. Prefix COSA (US)	Years Built	Flywheel Horsepower	Approx. Operating Weight kg (lb)	Track Gauge m (ft)	Height* m (ft)	Length* m (ft)	Width m (ft)	Max. Reach** m (ft)	Lift Capacity*** kg (lb)
330D	EAH	06-08	270	33 900	2.59 (8'6")	3.34 (10'11")	11.15 (36'7")	3.19 (10'6")	11.64 (38'2")	17 000 (36,550)
	JJM			(74,740)						
	KAB									
	LCJ									
	MEY									
330D L	PCK	06-08	270	35 100 (77,380)	2.59 (8'6")	3.34 (10'11")	11.15 (36'7")	3.29 (10'10")	11.64 (38'2")	17 000 (36,700)
	PFC									
	B6H									
	EDX									
	ERN									
	FFK									
	GBC									
	HAS									
	JLP									
	LDR									
	LRM									
	MAG									
	MWP									
	NBD									
	NEF									
R2D										
RAS										
RDA										
RDK										
T2Y										
THJ										
330D LN	GGE	06-08	270	34 900 (76,940)	2.39 (7'10")	3.34 (10'11")	11.15 (36'7")	2.99 (9'10")	11.64 (38'2")	17 000 (36,700)
336D	EMX	09-13	270	33 900	2.59 (8'6")	3.34 (10'11")	11.15 (36'7")	3.19 (10'6")	11.64 (38'2")	17 000 (36,550)
	JBT			(74,740)						
	JER									
	KKT									
	PGW									

\*When shipped with medium stick and bucket curled under.

\*\*Maximum reach at ground level, one-piece boom, longest stick.

\*\*\*Lift capacity at 4.6 m (15'0") over front, one-piece boom, longest stick.

## Hydraulic Excavators (Track) (cont'd)

Model	Product Ident. No. Prefix COSA (US)	Years Built	Flywheel Horsepower	Approx. Operating Weight kg (lb)	Track Gauge m (ft)	Height* m (ft)	Length* m (ft)	Width m (ft)	Max. Reach** m (ft)	Lift Capacity*** kg (lb)
336D L	DTS J2F JBF JWR KDJ LMG M2P M4T MDS MPL NLS PPN PRF PTB SKE W3K WET WRK ZML	09-13	270	35 100 <b>(77,380)</b>	2.59 <b>(8'6")</b>	3.34 <b>(10'11")</b>	11.15 <b>(36'7")</b>	3.29 <b>(10'10")</b>	11.64 <b>(38'2")</b>	17 000 <b>(36,700)</b>
336D LN	L5K MYG MYP	09-13	270	34 900 <b>(76,940)</b>	2.39 <b>(7'10")</b>	3.34 <b>(10'11")</b>	11.15 <b>(36'7")</b>	2.99 <b>(9'10")</b>	11.64 <b>(38'2")</b>	17 000 <b>(36,700)</b>
336E	CMR KED	11-16	306	34 600 <b>(76,280)</b>	2.59 <b>(8'6")</b>	3.51 <b>(11'6")</b>	11.16 <b>(36'7")</b>	3.19 <b>(10'6")</b>	11.72 <b>(38'5")</b>	
336E L	BMH BZY DPX FJH GTJ JRJ TEG YCE YEP	11-16	306	37 300 <b>(82,200)</b>	2.59 <b>(8'6")</b>	3.51 <b>(11'6")</b>	11.16 <b>(36'7")</b>	3.29 <b>(10'10")</b>	11.72 <b>(38'5")</b>	20 100 <b>(43,450)</b>
336E LN	TMZ	11-16	306	35 700 <b>(78,700)</b>	2.39 <b>(7'10")</b>	3.51 <b>(11'6")</b>	11.16 <b>(36'7")</b>	2.99 <b>(9'10")</b>	11.72 <b>(38'5")</b>	20 550 <b>(44,550)</b>
336E H	HDW	13-16	306	34 800 <b>(76,720)</b>	2.59 <b>(8'6")</b>	3.51 <b>(11'6")</b>	11.19 <b>(36'9")</b>	3.19 <b>(10'6")</b>	11.72 <b>(38'5")</b>	
336E L H	GNV JEA RZA	13-16	306	37 200 <b>(82,000)</b>	2.59 <b>(8'6")</b>	3.51 <b>(11'6")</b>	11.19 <b>(36'9")</b>	3.29 <b>(10'10")</b>	11.72 <b>(38'5")</b>	19 250 <b>(41,650)</b>
336E LN H	SSL	13-16	306	35 500 <b>(78,300)</b>	2.39 <b>(7'10")</b>	3.51 <b>(11'6")</b>	11.19 <b>(36'9")</b>	2.99 <b>(9'10")</b>	11.72 <b>(38'5")</b>	19 850 <b>(42,950)</b>
340D L	JTN	11-13	270	38 200 <b>(84,220)</b>	2.92 <b>(9'7")</b>	3.59 <b>(11'9")</b>	11.15 <b>(36'7")</b>	3.52 <b>(11'7")</b>	11.08 <b>(36'4")</b>	18 520 <b>(40,830)</b>

\*When shipped with medium stick and bucket curled under.

\*\*Maximum reach at ground level, one-piece boom, longest stick.

\*\*\*Lift capacity at 4.6 m (15'0") over front, one-piece boom, longest stick.

## Hydraulic Excavators (Track) (cont'd)

Model	Product Ident. No. Prefix COSA (US)	Years Built	Flywheel Horsepower	Approx. Operating Weight kg (lb)	Track Gauge m (ft)	Height* m (ft)	Length* m (ft)	Width m (ft)	Max. Reach** m (ft)	Lift Capacity*** kg (lb)
345B	4SS	97-00	290	44 050 <b>(97,100)</b>	2.74 <b>(9'0")</b>	3.76 <b>(12'4")</b>	11.79 <b>(33'8")</b>	3.49 <b>(11'5")</b>	13.0 <b>(42'8")</b>	20 850 <b>(45,000)</b>
345B L	7KS(GOS) 2SW(GOS)	98-00	290	47 665 <b>(105,080)</b>	2.39 <b>(7'10")</b>	3.68 <b>(12'1")</b>	11.74 <b>(38'6")</b>	2.99 <b>(9'10")</b>	12.97 <b>(42'6")</b>	21 000 <b>(46,300)</b>
345B L Series II	CCC(VG) FEE(FG) DET(MH)	01-05	321	48 960 <b>(107,960)</b>	2.39 <b>(7'10")</b>	3.87 <b>(12'8")</b>	11.46 <b>(37'7")</b>	2.99 <b>(9'10")</b>	11.69 <b>(38'4")</b>	19 250 <b>(42,450)</b>
345C L	ELS(FG) GCL(VG)	05-08	325	50 500 <b>(111,350)</b>	2.39 <b>(7'10")</b>	3.74 <b>(12'3")</b>	11.84 <b>(38'10")</b>	2.99 <b>(9'10")</b>	11.70 <b>(38'5")</b>	20 100 <b>(44,320)</b>
345C L	LYS(FG) GPH(VG) FPC(VG)	05-08	325	50 500 <b>(111,350)</b>	2.39 <b>(7'10")</b>	3.74 <b>(12'3")</b>	11.84 <b>(38'10")</b>	2.99 <b>(9'10")</b>	11.70 <b>(38'5")</b>	20 100 <b>(44,320)</b>
345D	NEG BYW, FES		380	44 490 <b>(98,084)</b>	2.89 <b>(9'6")</b>	3.94 <b>(13'0")</b>	11.90 <b>(39'1")</b>	3.49 <b>(11'5")</b>	11.70 <b>(38'5")</b>	9050 <b>(19,500)</b>
345D L	PBT RAE BYC YEE DPA, HLC EEH, RAJ RGG RDC, MLK RBT, RGD			47 200 <b>(104,060)</b>	2.89 <b>(9'6")</b>	3.94 <b>(13'0")</b>	11.90 <b>(39'1")</b>	3.49 <b>(11'5")</b>	11.70 <b>(38'5")</b>	9050 <b>(19,500)</b>
349D	MEN GKF	11-14	380	44 490 <b>(98,084)</b>	2.89 <b>(9'6")</b>	3.94 <b>(13'0")</b>	11.9 <b>(39'1")</b>	3.49 <b>(11'5")</b>	11.7 <b>(38'5")</b>	9050 <b>(19,500)</b>
349D L	NNF KLH PZG WTD) JGB KHS RBJ	11-14	380	47 200 <b>(104,060)</b>	2.89 <b>(9'6")</b>	3.94 <b>(13'0")</b>	11.9 <b>(39'1")</b>	3.49 <b>(11'5")</b>	11.7 <b>(38'5")</b>	9050 <b>(19,500)</b>
349E L (FG)	TFG MPZ	11-14	317	48 500 <b>(106,900)</b>	2.74 <b>(9'0")</b>	3.73 <b>(12'3")</b>	11.92 <b>(39'1")</b>	3.49 <b>(11'5")</b>	12.12 <b>(39'9")</b>	23 850 <b>(55,200)</b>
349E L (VG)	KCN DGE	11-14	317	51 200 <b>(112,900)</b>	2.89 <b>(9'6")</b>	3.55 <b>(11'8")</b>	11.82 <b>(38'9")</b>	3.64 <b>(11'11")</b>	12.09 <b>(39'8")</b>	24 100 <b>(55,700)</b>
350	7RK	93-99	286	48 040 <b>(105,910)</b>	2.55 <b>(8'4.4")</b>	3.75 <b>(12'3.6")</b>	12.2 <b>(40'3")</b>	3.2 <b>(10'6")</b>	13.45 <b>(44'1.5")</b>	17 750 <b>(39,100)</b>
	2ZL	93-99	286	50 094 <b>(110,210)</b>	2.55 <b>(8'4.4")</b>	3.75 <b>(12'4")</b>	12.2 <b>(40'0")</b>	3.3 <b>(10'10")</b>	13.49 <b>(44'3")</b>	17 750 <b>(39,100)</b>
350 L	9DK	93-99	286	49 010 <b>(108,050)</b>	2.55 <b>(8'4.4")</b>	3.75 <b>(12'3.6")</b>	12.2 <b>(40'3")</b>	3.3 <b>(10'9.9")</b>	13.45 <b>(44'1.5")</b>	17 750 <b>(39,100)</b>
	3ML	93-99	286	51 126 <b>(112,450)</b>	2.55 <b>(8'4.4")</b>	3.75 <b>(12'4")</b>	12.2 <b>(40'0")</b>	3.3 <b>(10'10")</b>	13.49 <b>(44'3")</b>	17 600 <b>(40,900)</b>
365B L	9PZ(GOS)	99-02	385	66 245 <b>(146,050)</b>	2.75 <b>(9'0")</b>	4.57 <b>(15'0")</b>	12.17 <b>(39'11")</b>	3.50 <b>(11'6")</b>	14.04 <b>(46'1")</b>	29 200 <b>(64,370)</b>
365B L Series II	JMB(EAME) DER(NACD) PEG(FS)	02-04	404	70 250 <b>(154,900)</b>	2.75 <b>(9'0")</b>	4.7 <b>(15'5")</b>	12.54 <b>(41'2")</b>	3.42 <b>(11'3")</b>	14.09 <b>(16'3")</b>	13 040 <b>(28,750)</b>

\*When shipped with medium stick and bucket curled under.

\*\*Maximum reach at ground level, one-piece boom, longest stick.

\*\*\*Lift capacity at 4.6 m (15'0") over front, one-piece boom, longest stick.



## Hydraulic Excavators (Track) (cont'd)

Model	Product Ident. No. Prefix COSA (US)	Years Built	Flywheel Horsepower	Approx. Operating Weight kg (lb)	Track Gauge m (ft)	Height* m (ft)	Length* m (ft)	Width m (ft)	Max. Reach** m (ft)	Lift Capacity*** kg (lb)
374D L	PJA PAX PAP PAS PAC	Sep 2010	355 kW <b>(476 hp)</b>	71 132 <b>(156,819)</b> Reach Boom R3.6 <b>(11'10")</b> Stick 3.8 m <sup>3</sup> <b>(5.0 yd<sup>3</sup>)</b> Bucket 650 mm <b>(26 in)</b> Shoe	2.75 <b>(9'0")</b> Shipping 3.41 <b>(11'2")</b> Working	4.48 <b>(14'8")</b> Reach Boom R3.6 <b>(11'10")</b> Stick	13.32 <b>(43'8")</b> Reach Boom R3.6 <b>(11'10")</b> Stick	3.5 <b>(11'6")</b> Transportation 750 mm <b>(30 in)</b> Shoe	14.23 <b>(46'8")</b> Reach Boom R4.67m <b>(15'4")</b> Stick 3.8 m <sup>3</sup> <b>(5.0 yd<sup>3</sup>)</b> Bucket	17 300 <b>(39,900)</b> Reach Boom R4.67m <b>(15'4")</b> Stick 900 mm <b>(36 in)</b> Shoe Ground Level 4.5 m <b>(15'0")</b> Over Front
375	8WJ  6NK(GOS)	92-01  92-02	428  428	81 190 <b>(178,800)</b> 79 807 <b>(175,940)</b>	2.75 <b>(9'0")</b> 2.75 <b>(9'0")</b>	5.24 <b>(17'2")</b> 5.24 <b>(17'2")</b>	14.3 <b>(46'11")</b> 13.14 <b>(43'1")</b>	3.5 <b>(11'6")</b> 3.48 <b>(11'5")</b>	15.96 <b>(52'4")</b> 15.67 <b>(51'5")</b>	30 300 <b>(65,600)</b> 23 620 <b>(52,070)</b>
375 L	1JM  9WL(GOS)	93-01  92-02	428  428	82 380 <b>(181,500)</b> 80 700 <b>(177,910)</b>	2.94 <b>(9'7")</b> 2.75 <b>(9'0")</b>	5.24 <b>(17'2")</b> 5.24 <b>(17'2")</b>	14.3 <b>(46'11")</b> 14.29 <b>(46'11")</b>	3.84 <b>(12'7")</b> 3.48 <b>(11'5")</b>	15.96 <b>(52'4")</b> 15.67 <b>(51'5")</b>	29 550 <b>(64,400)</b> 23 620 <b>(52,070)</b>
385B L	FDL(EAME) RCD(NACD) CLS(EAME) MYA(NACD)	01-04	513	89 130 <b>(196,530)</b>	2.75 <b>(9'0")</b>	5.16 <b>(16'11")</b>	14.6 <b>(47'11")</b>	3.73 <b>(12'3")</b>	15.61 <b>(51'2")</b>	13 810 <b>(30,450)</b>
390D L	WAG WBT WAP	Nov 2010	390 kW <b>(523 hp)</b>	86 190 <b>(190,016)</b> GP Boom <b>(27'7")</b> R4.4m <b>(14'5")</b> Stick 4.6 m <sup>3</sup> <b>(6.0 yd<sup>3</sup>)</b> HD Bucket 650 mm <b>(26 in)</b> Shoe	2.75 <b>(9'0")</b> Shipping 3.51 <b>(11'6")</b> Working	5.16 <b>(16'11")</b> GP Boom <b>(27'7")</b> GP3.4m <b>(11'2")</b> Stick	14.72 <b>(48'4")</b> GP Boom <b>(27'7")</b> GP3.4m <b>(11'2")</b> Stick	4.26 <b>(14'0")</b> Transportation 750 mm <b>(30 in)</b> Shoe	17.25 <b>(56'7")</b> Reach Boom R5.5m <b>(18'1")</b> Stick 3.9 m <sup>3</sup> <b>(5.1 yd<sup>3</sup>)</b> Bucket	11 350 <b>(25,900)</b> Reach Boom R5.5m <b>(18'1")</b> Stick 900 mm <b>(36 in)</b> Shoe -1.5 m <b>(-5.0 ft)</b> 4.5 m <b>(15'0")</b> Over Front
5090B	CLD EAME SJJ NACD	01-04	512	87 500 <b>(192,937)</b>	3.5 <b>(11.51)</b>	4.63 <b>(15.19)</b>	14.26 <b>(46.77)</b>	3.47 <b>(11.38)</b>	10.35 <b>(33.95)</b>	— —

\*When shipped with medium stick and bucket curled under.

\*\*Maximum reach at ground level, one-piece boom, longest stick.

\*\*\*Lift capacity at 4.6 m (15'0") over front, one-piece boom, longest stick (6.1 m (20'0") over front for 375/375 L).



## HYDRAULIC EXCAVATORS (Wheel)

Model	Product Ident. No. Prefix (USA)	Years Built	Flywheel Horsepower	Approx. Operating Weight kg (lb)	Height* m (ft)	Length* m (ft)	Width m (ft)	Max. Reach** m (ft)	Lift Capacity*** kg (lb)	Standard Tire Size
206	(2RC) (3GC)	84-90	Deutz-67 Perkins-71	12 185 <b>(26,863)</b>	3.11 <b>(10'2")</b>	7.38 <b>(24'2.5")</b>	2.40 <b>(7'10")</b>	8.14 <b>(26'9")</b>	3360 <b>(7400)</b>	Dual 9.00-20 12PR
212	(3JC) (5DC)	84-90	Deutz-84 Perkins-94	13 700 <b>(30,423)</b>	3.15 <b>(10'4")</b>	8.00 <b>(26'3")</b>	2.49 <b>(8'2")</b>	9.86 <b>(32'4")</b>	3850 <b>(8490)</b>	Dual 10.00-20 12PR
212B	(3PJ)	90-95	110	14 000 <b>(30,870)</b>	3.04 <b>(10'0")</b>	8.28 <b>(27'2")</b>	2.49 <b>(8'2")</b>	9.48 <b>(31'1")</b>	3900 <b>(8600)</b>	Dual 10.00-20 12PR
214	(9MB) (1KB)	84-88	Deutz-101 Perkins-102	15 600 <b>(34,175)</b>	3.06 <b>(10'0")</b>	8.28 <b>(27'2")</b>	2.49 <b>(8'2")</b>			Dual 10.00-20 12PR
214B	4CF	88-94	110	18 700 <b>(41,230)</b>	3.06 <b>(10'0")</b>	8.28 <b>(27'2")</b>	2.49 <b>(8'2")</b>	10.41 <b>(34'2")</b>	4200 <b>(9260)</b>	Dual 10.00-20 12PR
214B FT	9NF	88-94	135	18 700 <b>(41,230)</b>	3.06 <b>(10'0")</b>	8.28 <b>(27'2")</b>	2.49 <b>(8'2")</b>	10.41 <b>(34'2")</b>	4200 <b>(9260)</b>	Dual 10.00-20 12PR
224	(2JC) (5TC)	84-89	Deutz-143 Perkins-124	19 000 <b>(41,890)</b>	3.42 <b>(11'3")</b>	8.98 <b>(29'6")</b>	2.49 <b>(8'2")</b>	10.61 <b>(34'10")</b>	4800 <b>(10,600)</b>	Dual 10.00-20 12PR
224B	7WF	89-95	135	21 000 <b>(46,297)</b>	3.95 <b>(13'0")</b>	9.08 <b>(29'9")</b>	2.65 <b>(8'8")</b>	10.75 <b>(35'3")</b>	4800 <b>(10,582)</b>	Dual 11.00-20 14PR

\*When shipped with medium stick and bucket curled under.

\*\*Maximum reach at ground level, one-piece boom, longest stick.

\*\*\*Lift capacity at 4.6 m (15'0") over front, one-piece boom, longest stick.

## Hydraulic Excavators (Wheel) (cont'd)

Model	Product Ident. No. Prefix (USA)	Years Built	Flywheel Horsepower	Approx. Operating Weight kg (lb)	Height* m (ft)	Length* m (ft)	Width m (ft)	Max. Reach** m (ft)	Lift Capacity*** kg (lb)	Standard Tire Size
M312	6TL	96-02	114	13 425 (29,602)	3.07 (10'1")	8.62 (28'3")	2.5 (8'2")	8.9 (29'2")	4300 (9482)	10-20.00 14PR
M313C	H2A BDR	05-06 02-05	118	13 100-14 750 (28,886-35,524)	3.12 (10'2")	8.08 (26'6")	2.55 (8'4")	8.77 (28'9")	4800 (10,584)	10.00-20 16PR
M313D	J3A W3H	12-13 07-12	127	14 000-16 200 (30,870-35,721)	3.12 (10'3")	8.08 (26'6")	2.55 (8'4")	8.77 (28'10")	4800 (10,582)	10.00-20 16PR
M315	7ML	95-02	117	15 570 (34,332)	3.08 (10'1")	8.84 (29'0")	2.5 (8'2")	9.26 (30'5")	5100 (11,246)	10-20.00 14PR
M315C	H2B BDM	05-06 02-05	129	15 000-16 650 (33,075-36,713)	3.15 (10'4")	8.33 (27'4")	2.55 (8'4")	9.17 (30'1")	5600 (12,348)	10.00-20 16PR
M315D	J5B W5M	12-13 07-12	136	16 100-18 300 (35,501-40,352)	3.15 (10'4")	8.33 (27'4")	2.55 (8'4")	9.17 (30'1")	5700 (12,566)	10.00-20 16PR
M316C	H2C BDX	05-06 02-05	138	16 300-18 200 (35,942-40,131)	3.17 (10'5")	8.40 (27'7")	2.55 (8'4")	9.17 (30'1")	6500 (14,330)	10.00-20 16PR
M316D	D6W W6A	11-13 07-11	158	17 000-19 200 (37,478-42,329)	3.17 (10'5")	8.4 (27'7")	2.55 (8'4")	9.17 (30'1")	6400 (14,110)	10.00-20 16PR
M318	8AL	95-02	131	17 870 (39,403)	3.1 (10'2")	8.97 (29'5")	2.6 (8'6")	10.55 (34'7")	6400 (14,112)	10-20.00 14PR
M318C	H2D BCZ	05-06 02-05	151	17 800-19 700 (39,249-43,439)	3.21 (10'6")	8.96 (29'5")	2.55 (8'4")	9.60 (31'6")	6600 (14,550)	10.00-20 16PR
M318D	D8W W8P	11-13 07-11	166	18 200-20 100 (40,124-44,312)	3.17 (10'5")	8.96 (29'5")	2.55 (8'4")	9.6 (31'6")	6600 (14,550)	10.00-20 16PR
M320	6WL	97-02	131	20 200 (44,541)	3.21 (10'6")	9.55 (31'4")	2.75 (9'0")	11.18 (36'8")	7500 (16,538)	11-20.00 14PR
M322C	H2E BDK	05-06 02-05	164	20 500-22 700 (45,203-50,054)	3.25 (10'8")	9.64 (31'7")	2.75 (9'0")	10.32 (33'10")	7300 (16,093)	11.00-20 16PR
M322D	D2W W2S	11-13 07-11	164	20 500-22 500 (45,195-49,604)	3.20 (10'6")	9.64 (31'7")	2.75 (9'0")	10.32 (33'10")	7200 (15,873)	11.00-20 16PR

\*When shipped with medium stick and bucket curled under, one-piece boom.

\*\*Maximum reach at ground level, one-piece boom, longest stick.

\*\*\*Lift capacity at 4.6 m (15'0") over front, rear dozer up, one-piece boom, longest stick.



## 5000 SERIES EXCAVATORS AND FRONT SHOVELS

Model	Product Ident. No. Prefix COSA (US)	Years Built	Flywheel Horsepower	Approx. Operating Weight kg (lb)	Track Gauge m (ft)	Height* m (ft)	Length* m (ft)	Width m (ft)	Max. Reach** m (ft)	Lift Capacity*** kg (lb)
5080	6XK(GOS)	94-02	428	83 800 (184,750)	2.75 (9'0")	4.73 (15'6")	13.76 (45'2")	3.48 (11'5")	9.76 (32'0")	—
5090B	CLD(EAME) SJY(NACD)	01-04	512	87 500 (192,940)	3.51 (11'6")	4.63 (15'2")	14.26 (46'9")	3.47 (11'5")	10.35 (33'11")	—

\*When shipped with medium stick and bucket curled under.

\*\*Maximum reach at ground level, one-piece boom, longest stick.

\*\*\*Lift capacity at 4.6 m (15'0") over front, one-piece boom, longest stick.

Model	Product Ident. No. Prefix (USA)	Years Built	Flywheel Horsepower	Approx. Operating Weight kg (lb)	Rated* Capacity m <sup>3</sup> (yd <sup>3</sup> )	Breakout Force kN (lb)	Crowd Force kN (lb)	Track Gauge m (ft)	Max. Reach* m (ft)	Max. Load Height m (ft)	Max. Digging Depth m (ft)
5110B ME	AAA	00-03	696	127 000 (280,000)	7.6 (9.9)	501 (112,600)	439 (98,800)	4.1 (13.4')	13.9 (45.7')	8.6 (28.0')	7.9 (25.9')
5110B L	AAK	02-03	696	129 000 (284,000)	4.6 (6.0)	463 (104,175)	377 (84,825)	4.1 (13.4')	16.39 (53.8')	10.06 (33.0')	10.51 (34.5')
5130 ME	5ZL	92-97	755	180 000 (397,000)	10.0 (13.0)	615 (138,400)	624 (140,300)	4.72 (15'6")	14.9 (48'11")	9.1 (29'10")	8.4 (27'7")
5130 FS	5ZL	92-97	755	179 000 (395,000)	10.5 (13.7)	715 (161,000)	770 (173,000)	4.72 (15'6")	12.4 (40'8")	9.1 (29'10")	—
5130B ME	4CS	97-03	800	182 000 (401,000)	10.5 (13.7)	672 (151,100)	624 (140,300)	4.72 (15.5')	14.9 (48.9')	9.1 (29.8')	8.4 (27.6')
5130B FS	4CS	97-03	800	181 000 (399,000)	11.0 (14.5)	715 (161,000)	770 (173,000)	4.72 (15.5')	12.4 (40.7')	9.1 (29.8')	—
5230 ME	7LL	94-00	1470	316 600 (698,000)	16.0 (21.0)	873 (196,260)	874 (196,480)	5.2 (17'0")	17.7 (58'0")	9.8 (32'2")	9.4 (30'10")
5230 FS	7LL	94-00	1470	318 422 (702,000)	17.0 (22.2)	1125 (253,000)	1250 (281,000)	5.2 (17'0")	14.8 (48'7")	10.3 (33'10")	—
5230B ME	4HZ	01-04	1550	328 100 (723,400)	16.0 (21.0)	855 (192,083)	885 (198,848)	5.196 (17.0')	17.8 (58.4')	9.8 (32.0')	9.5 (31.3')
5230B FS	4HZ	01-04	1550	327 000 (721,000)	17.0 (22.2)	1162 (261,145)	1145 (257,324)	5.196 (17.0')	14.9 (48.8')	10.4 (34.1')	—

\*Standard boom and stick.



## 6000 SERIES HYDRAULIC MINING SHOVELS

Model	Product Ident. No. Prefix	Years Built	Approx. Operating Weight kg (lb)	Flywheel Horsepower kW (hp)	Rated Capacity m <sup>3</sup> (yd <sup>3</sup> )	Breakout Force kN (lb)	Tearout/Crowd Force kN (lb)	Track Gauge m (ft)	Max. Reach m (ft)	Max. Load Height m (ft)	Max. Digging Depth m (ft)
6015	DHB	95-16	106 100 (233,910)	496 (665)	6.0 (7.8)	380 (85,400)	375 (84,270)	3.8 (12'6")	13.5 (44'3")	9.0 (29'6")	7.3 (23'11")
6015 ME*	DHB	96-16	106 000 (233,690)	496 (665)	7.0 (9.2)	410 (92,140)	390 (87,640)	3.8 (12'6")	12.6 (41'4")	9.2 (30'2")	6.0 (19'8")
6015 FS	DHF	95-16	104 900 (231,260)	496 (665)	7.0 (9.2)	480 (107,870)	645 (144,950)	3.8 (12'6")	10.5 (34'5")	8.8 (28'10")	—
6018	DHT	86-16	186 000 (410,060)	824 (1104)	10.0 (13.1)	510 (114,610)	540 (121,350)	4.5 (14'9")	15.6 (51'2")	8.9 (29'2")	8.5 (27'11")
6018 FS	DHD	86-16	183 400 (404,320)	824 (1104)	10.0 (13.1)	730 (164,050)	910 (204,500)	4.5 (14'9")	12.9 (42'4")	10.1 (33'2")	—

\*Mass Excavation backhoe attachment.



## WHEEL MATERIAL HANDLERS

Model	Product Ident. No. Prefix	Years Built	Flywheel Horsepower kW (hp)	Approx. Operating Weight kg (lb)	Max. Reach m (ft)	Lift Capacity* kg (lb)
M318 MH	6ES	98-02	104 (140)	19 500 (43,000)	10.5 (34'8")	2100 (4630)
	8SS	98-02	104 (140)	19 500 (43,000)	10.5 (34'8")	2100 (4630)
M318C MH	BEB	02-05	113 (151)	21 460 (47,311)	11.0 (36'1")	2100 (4630)
	H2F	05-06	113 (151)	21 460 (47,311)	11.0 (36'1")	2100 (4630)
M318D MH	D9X	11-13	124	18 200-20 100	11.0	2150
	W8R	07-11	(166)	(40,124-44,312)	(36'1")	(4740)
M320 MH	9PS	98-02	104	21 150	11.6	3200
			(140)	(46,600)	(38'0")	(7055)
M322C MH	BDY	02-05	122 (164)	24 690 (54,432)	12.5 (41'0")	2300 (5070)
	H2G	05-06	122 (164)	24 690 (54,432)	12.5 (41'0")	2300 (5070)
M322D MH	D3X	11-13	122	20 500-22 500	12.5	2050
	W2T	07-11	(164)	(45,195-49,604)	(41'0")	(4519)
325 WMH	2SL	98	125	35 100	13.4	4200
			(168)	(77,400)	(43'11")	(9400)
325B WMH	2JR	98	132	34 958	13.4	4700
			(177)	(77,000)	(43'11")	(10,400)
M325B MH	2JR	99-00	125 (168)	37 200 (82,040)	15.5 (50'10")	3040 (6700)
		BGN	01-04	125 (168)	37 200 (82,040)	15.5 (50'10")
M325C MH	XJA	03-06	128 (173)	31 500 (69,450)	15.65 (51'4")	2960 (6526)
M325C LMH	PAN	03-06	140 (189)	37 000 (81,570)	15.65 (51'4")	3510 (7738)
W330B MH	AME	00-02	165	52 800	14.4	4800
			(222)	(116,300)	(47'3")	(10,700)
W345B MH	ANJ	02	216 (290)	64 250 (141,650)	16.5 (54'0")	5300 (11,800)
		CDY	02-04	239 (321)	66 040 (145,288)	16.5 (54'0")
W345C MH	R5K	05	257	64 745	18.0	5150
			(345)	(142,740)	(59'1")	(11,400)
350 WMH	9FL	98	213 (286)	68 812 (151,800)	17.1 (56'3")	6300 (13,889)
	3ML	99	213 (286)	68 812 (151,800)	17.1 (56'3")	6300 (13,889)

\*Lift at maximum reach over front at 3 m (10 ft) elevation from stick pin, no tool.



## TRACK MATERIAL HANDLERS

Model	Product Ident. No. Prefix	Years Built	Flywheel Horsepower kW (hp)	Approx. Operating Weight kg (lb)	Max. Reach m (ft)	Lift Capacity* kg (lb)
320 MH	3XK	-99	96 (128)	23 030 (50,670)	12.4 (40'8")	2910 (6400)
	9KK	-99	96 (128)	23 030 (50,670)	12.4 (40'8")	2910 (6400)
320B MH	6LS	99-01	100 (134)	23 030 (50,670)	12.4 (40'8")	3150 (6900)
320C MH	BGB	01-02	103 (138)	25 530 (56,283)	12.4 (40'8")	3150 (6900)
	SAH	03-07	103 (138)	25 530 (56,283)	12.4 (40'8")	3150 (6900)
325 MH	2SL	-98	125 (168)	31 400 (69,237)	13.4 (43'11")	4130 (9100)
325B MH	2JR	98-02	132 (177)	33 236 (73,120)	13.4 (43'11")	4200 (9200)
325C MH	S2C	03-05	140 (188)	34 630 (76,350)	15.5 (50'10")	3000 (6600)
325D MH	RJK	05-12	152 (204)	35 526 (78,321)	15.5 (50'11")	3010 (6630)
	C4H	05-12	152 (204)	35 526 (78,321)	15.5 (50'11")	3010 (6630)
330 MH	5YM	-98	166 (222)	39 100 (86,215)	14.4 (47'3")	4080 (9000)
330B MH	6DR	98-02	165 (222)	41 430 (91,350)	14.4 (47'3")	4900 (10,800)
330C MH	D3C	03-05	184 (247)	43 815 (96,595)	15.9 (52'2")	3900 (8600)
330D MH	LEM	05-13	200 (268)	44 627 (98,386)	16.0 (52'6")	3670 (8090)
	C5K	05-13	200 (268)	44 627 (98,386)	16.0 (52'6")	3670 (8090)
345B MH	2NW	97-00	216 (290)	55 705 (122,550)	16.5 (54'0")	5300 (11,600)
345BII MH	APB	00-05	239 (321)	56 100 (123,420)	16.5 (54'0")	5300 (11,600)
345C MH	M2R	05-13	257 (345)	57 431 (126,615)	18.0 (59'1")	5000 (11,000)
	D3S	05-13	257 (345)	57 431 (126,615)	18.0 (59'1")	5000 (11,000)
350 MH	8KZ	-00	213 (286)	61 576 (135,630)	17.1 (56'3")	5350 (11,800)
	9FL	-00	213 (286)	61 576 (135,630)	17.1 (56'3")	5350 (11,800)
365B MH	CTY	02-03	287 (385)	74 470 (164,177)	18.9 (61'11")	6320 (13,540)
365BII MH	SDL	04	302 (404)	74 470 (164,177)	18.9 (62'3")	6320 (13,540)
365C MH	GWC	05-06	302 (404)	79 263 (174,744)	19.8 (65'1")	5400 (11,905)
375 MH	8SL	00	319 (428)	92 081 (203,000)	21.1 (69'3")	5900 (13,200)
	1JM	00-05	319 (428)	92 081 (203,000)	21.1 (69'3")	5900 (13,200)

\*Lift at maximum reach over front at 3 m (10 ft) elevation from stick pin, no tool.



## LOGGING AND FOREST PRODUCT MACHINES

Model	Product Ident. No. Prefix	Years Built	Flywheel Power kW (hp)	Overall Track Length m (ft)	Overall Length m (ft)	Overall Width m (ft)	Operating Weight kg (lb)
320B Stroke Delimber	9JS	—	96 (128)	—	11.96 (39'3")	3.66 (12'0")	30 390 (67,000)
FB221	8XD	1986	147 (197)	4.47 (14'8")	9.78 (32'1")	3.20 (10'6")	28 180 (62,000)
FB227	10W	1983-93	100/134 (135/180)	4.55 (14'11")	11.88 (39'0")	3.35 (11'0")	31 769 (69,892)
DL221	8YD	1987	98 (132)	4.47 (14'8")	—	—	22 816 (50,300)
LL216	8JD	1986	95 (128)	—	10.70 to 11.23 (35'1" to 36'10")	2.64 (8'8")	17 577 (38,750)
LL228	8MD	1986	131 (176)	—	9.7 to 11.6 (32'0" to 38'0")	2.62 (8'7")	30 391 (67,000)
LL231	8PD	1986	175 (235)	5.03 (16'6")	10.6 to 11.6 (35'0" to 38'0")	3.56 (11'8")	39 146 (86,300)
320B LL	6LS/9JS	96-01	96 (128)	4.48 (14'8")	—	3.29 (10'10")	28 610 (63,100)
320C LL	BGB/BKK	01-03	96 (128)	4.5 (14'8")	—	3.3 (10'10")	25 900 (57,100)
320C LL	SAH/TBR	02-07	103 (138)	4.6 (14'9")	—	3.3 (10'10")	27 200 (59,965)
320D LL	GKS	07-14	110 (147)	4.6 (14'9")	—	3.3 (10'10")	30 300 (66,812)
320D GF	BZF/EAX	06-14	110 (147)	4.6 (14'9")	—	3.3 (10'10")	26 900 (59,315)
322B LL	1YS	96-02	114 (153)	4.66 (15'3")	—	3.72 (12'3")	32 970 (72,686)
322C FM GF (HD/LC)	BPH	01-06	125 (168)	4.66 (15'4")	9.96 (32'8")	3.29 (10'10")	28 229 (62,245)*
322C FM GF (HW)	CAM	01-06	125 (168)	4.69 (15'5")	9.91 (32'6")	3.62 (11'11")	30 710 (67,716)*
322C FM LL (U/U)	CBY	01-06	125 (168)	4.69 (15'5")	14.10 (46'3")	3.62 (11'11")	33 607 (74,103)*
322C FM LL (O/U)	CBY	01-06	125 (168)	4.69 (15'5")	15 (49'3")	3.62 (11'11")	33 896 (74,741)*

\*Operating Weight without bucket or grapple and with the new FM Cab/Riser with integrated guarding (available in July 2004).



## Logging and Forest Product Machines (cont'd)

Model	Product Ident. No. Prefix	Years Built	Flywheel Power kW (hp)	Overall Track Length m (ft)	Overall Length m (ft)	Overall Width m (ft)	Operating Weight kg (lb)
324D FM LGP	JGK	07-10	140 (188)	4.7 (15.3)	13 (42.7)	3.62 (11.9)	32 886 (72,500)
325B LL	2JR	96-01	124 (166)	4.66 (15'3")	—	3.62 (11'11")	36 916 (81,400)
325C FM GF (HD/LC)	G1L	02-06	140 (188)	4.70 (15'5")	10.34 (33'11")	3.44 (11'3")	31 942 (70,432)*
325C FM GF (HW)	M2K	02-06	140 (188)	4.70 (15'5")	10.29 (33'9")	3.62 (11'11")	33 078 (72,937)*
325C FM LL (U/U)	S3M	02-06	140 (188)	4.70 (15'5")	14.87 (48'9")	3.62 (11'11")	37 644 (83,005)*
325C FM LL (O/U)	S3M	02-06	140 (188)	4.70 (15'5")	15.75 (51'8")	3.62 (11'11")	38 219 (84,273)*
330B LL	6DR	96-02	160 (214)	5.02 (16'6")	—	3.62 (11'11")	44 172 (97,400)
330C FM GF (HD/LC)	B3M	02-06	184 (247)	5.08 (16'8")	11.19 (36'9")	3.52 (11'6")	39 347 (86,760)*
330C FM GF (HW)	B4N	02-06	184 (247)	5.07 (16'7")	11.19 (36'9")	3.62 (11'11")	40 778 (89,915)*
330C FM LL (U/U)	B1K	02-06	184 (247)	5.07 (16'7")	16.67 (54'8")	3.62 (11'11")	44 430 (97,968)*
330C FM LL (O/U)	B1K	02-06	184 (247)	5.07 (16'7")	17.36 (57'0")	3.62 (11'11")	44 965 (99,148)*
330D FM GF	L2K	06-10	200 (268)	5.06 (16'7")	111.15 (367'7")	3.65 (11'11")	41 426 (91,344)
330D FM LL (U/U)	H3K	06-10	200 (268)	5.06 (16'7")	166.3 (547'7")	3.65 (11'11")	45 801 (100,991)
330D FM LL (O/U)	H3K	06-10	200 (268)	5.06 (16'7")	173.2 (567'10")	3.65 (11'11")	46 261 (102,005)

\*Operating Weight without bucket or grapple and with the new FM Cab/Riser with integrated guarding (available in July 2004).



**WHEEL SKIDDERS**

Model	Product Ident. No. Prefix	Years Built	Flywheel Horsepower kW (hp)	Operating Weight kg (lb)	Ground Clearance mm (in)	Wheel Base m (ft/in)
508 Cable	9NC	87-89	71 (95)	7770 (17,130)	521 (20.5)	2.8 (9'2")
508 Grapple	2HD	87-89	71 (95)	8766 (19,308)	521 (20.5)	2.8 (9'2")
518 FB	8ZC	86-89	96 (130)	11 612 (25,600)	587 (23.1)	3.25 (10'8")
518 PS Cable	50S	71-83	90 (120)	7718 (17,000)	505.4 (19.8976)	2895.6 (9'6")
518 PS Grapple	55U	1-80/81-83	90/97 (120/130)	9307 (20,500)	505.4 (19.8976)	2895.6 (9'6")
518 Cable	94U	3-84/85-92	90/97 (120/130)	9988 (22,000)	470 (18.5039)	3251 (10'8.4")
518 Grapple	95U	81-90	97 (130)	11 259 (24,800)	470 (18.5039)	3251 (10'8.4")
518 Series II Cable	94U	91-92	dual 97/108 dual (130/145)	10 260 (22,600)	470 (18.5039)	3251 (10'8.4")
518 Series II Grapple	95U	91-92	dual 97/108 dual (130/145)	12 031 (26,500)	470 (18.5039)	3251 (10'8.4")
518C Cable	1CL	93-95	115 (154)	11 528 (25,391)	450.7 (17.74406)	3251 (10'8.4")
518C Grapple	9HJ	93-95	115 (154)	12 587 (27,725)	463.4 (18.24406)	3251 (10'8.4")
525	—	—	119 (160)	13 558 (29,891)	527 (20.7)	3.5 (11.5)
525B	—	02-06	119 (160)	18 325 (40,400)	463 (18.2)	3.5 (11.5)
525C	—	06-14	146 (196)	17 711 (39,045)	581 (22.9)	3534 (11'7")
535B	—	6-Feb	134 (180)	19 006 (41,900)	463 (18.2)	3.5 (11.5)
535C	—	06-14	162 (218)	18 044 (39,780)	581 (22.9)	3534 (11'7")
545 Grapple	—	6-Feb	149.1 (225)	20 230 (44,600)	606.4 (23.9)	3.8 (12.5)
545C	—	06-14	173 (232)	19 198 (42,325)	581 (22.9)	3939 (12'11")



**TRACK SKIDDERS**

Model	Product Ident. No. Prefix	Years Built	Flywheel Horsepower kW (hp)	Operating Weight kg (lb)	Gauge m (ft/in)
D4TSK Series II	8ZF	90-92	78 (105)	12 909 (28,400)	2.00 (6'6")
D4TSK Series III	7PK	92-96	78 (105)	14 000 (30,900)	2.00 (6'6")
D5HTSK Series II	7EG	92-96	97 (130)	18 800 (41,360)	2.16 (7'11")

## Former Models

Track Feller Bunchers  
 Forwarders  
 Track Harvester  
 Wheel Harvester



### TRACK FELLER BUNCHERS

Model	Product Ident. No. Prefix	Years Built	Gross Power kW (hp)	Overall Track Length m (ft)	Overall Length m (ft)	Overall Width m (ft)	Operating Weight kg (lb)
511	511	06-12	184.2 (247)	4.6 (15.0)	8.5 (27.7)	3.2 (10.5)	24 362 (53,710)
521	521	06-12	211.8 (284)	4.8 (15.8)	8.6 (28.3)	3.2 (10.5)	27 084 (59,710)
522	522	06-12	211.8 (284)	4.8 (15.8)	8.6 (28.3)	3.5 (11.4)	30 410 (67,040)
532	532	06-12	211.8 (284)	4.9 (16.1)	8.6 (28.3)	3.5 (11.4)	31 620 (69,710)
541	541	06-11	227.4 (305)	4.9 (16.1)	9.4 (30.9)	3.6 (11.8)	30 191 (66,560)
551	551	06-11	227.4 (305)	4.9 (16.1)	9.4 (30.9)	3.6 (11.8)	31 057 (68,468)
552	552	06-11	227.4 (305)	4.9 (16.1)	9.4 (30.9)	3.6 (11.8)	35 680 (78,660)



### FORWARDERS

Model	Product Ident. No. Prefix	Years Built	Number of Wheels	Engine	Gross Power kW (hp)	Operating Weight kg (lb)	Load Capacity kg (lb)	Transmission	Std. Wheel Base mm (in)
534	HF	06-11	4	C4.4 ACERT	93 (125)	12 247 (27,000)	7258 (16,000)	Electric Powershift	3835 (151)
544	HF	06-11	6	C4.4 ACERT	93 (125)	14 062 (31,000)	10 866 (24,000)	Electric Powershift	5334 (210)
584	PAK	09-14	8	C7 ACERT	204 (274)	22 498 (49,600)	18 000 (39,683)	2 Speed Hydrostatic	6096 (240)



### TRACK HARVESTER

Model	Product Ident. No. Prefix	Years Built	Engine	Gross Power kW (hp)	Track Pitch mm (in)	Overall Height m (ft)	Overall Width m (ft)	Operating Weight kg (lb)
501	PH	06-12	C6.6 ACERT	122 (163)	171.4 (6.7)	3.33 (11.9)	2.59 (8.5)	15 900 (35,000)



### WHEEL HARVESTER

Model	Product Ident. No. Prefix	Years Built	Number of Wheels	Engine	Gross Power kW (hp)	Transmission	Boom Reach m (ft)	Std. Wheel Base mm (in)	Operating Weight kg (lb)
550	PH	06-13	6	C7 ACERT	147 (197)	Hydrostatic	8.2 (27)	4160 (164)	21 319 (47,040)



## BACKHOE LOADERS

Model	Product Ident. No. Prefix	Years Built	Flywheel Horsepower kW (hp)	Operating Weight kg (lb)	Digging Depth mm (ft/in)	GP Bucket Capacity m <sup>3</sup> (yd <sup>3</sup> )	MP Bucket Capacity m <sup>3</sup> (yd <sup>3</sup> )
416	5PC	85-90	46 <b>(62)</b>	6156 <b>(13,574)</b>	4420 <b>(14'6")</b>	0.76 <b>(1.0)</b>	0.76 <b>(1.0)</b>
416 Series II	5PC	90-92	46 <b>(62)</b>	6217 <b>(13,708)</b>	4420 <b>(14'6")</b>	0.76 <b>(1.0)</b>	0.76 <b>(1.0)</b>
416B	8ZK(8SG)	92-95	59 <b>(79)</b>	6227 <b>(13,700)</b>	4420 <b>(14'6")</b>	0.76 <b>(1.0)</b>	0.96 <b>(1.25)</b>
416C	4ZN(5YN)	96-00	56 <b>(75)</b>	6330 <b>(13,957)</b>	4420 <b>(14'6")</b>	0.76 <b>(1.0)</b>	0.96 <b>(1.25)</b>
416C (IT)	1WR(1XR)	96-00	56 <b>(75)</b>	6666 <b>(14,698)</b>	4420 <b>(14'6")</b>	0.96 <b>(1.25)</b>	0.96 <b>(1.25)</b>
416D	BFP, BKG, BGJ, CXP	00-05	58 <b>(78)</b>	6900 <b>(15,257)</b>	4390 <b>(14'5")</b>	0.76 <b>(1.0)</b>	0.96 <b>(1.25)</b>
420D	FDP, BKC	00-05	69 <b>(93)</b>	7150 <b>(15,772)</b>	4390 <b>(14'5")</b>	0.96 <b>(1.25)</b>	0.96 <b>(1.25)</b>
420D (IT)	BLN, BMC, MBH	00-05	69 <b>(93)</b>	7150 <b>(15,772)</b>	4390 <b>(14'5")</b>	0.96 <b>(1.25)</b>	0.96 <b>(1.25)</b>
424D	RXA, CJZ	01-05	56 <b>(75)</b>	7502 <b>(16,539)</b>	4854 <b>(15'9")</b>	1.0 <b>(1.31)</b>	0.96 <b>(1.25)</b>
426	7BC	86-90	52 <b>(70)</b>	6549 <b>(14,626)</b>	4720 <b>(15'6")</b>	0.96 <b>(1.25)</b>	0.76 <b>(1.0)</b>
426 Series II	7BC	90-92	52 <b>(70)</b>	7315 <b>(15,126)</b>	4720 <b>(15'6")</b>	0.96 <b>(1.25)</b>	0.76 <b>(1.0)</b>
426B	6KL(5YJ)	92-95	59 <b>(79)</b>	6790 <b>(14,970)</b>	4720 <b>(15'6")</b>	0.96 <b>(1.25)</b>	0.96 <b>(1.25)</b>
426C	6XN(7WN)	96-98	60 <b>(80)</b>	7051 <b>(15,548)</b>	4721 <b>(15'6")</b>	0.96 <b>(1.25)</b>	0.96 <b>(1.25)</b>
426C	6XN3616 and up (7WN939 and up)	99-00	63 <b>(85)</b>	7051 <b>(15,548)</b>	4721 <b>(15'6")</b>	0.96 <b>(1.25)</b>	0.96 <b>(1.25)</b>
(AWS) 426C	1CR(1ER)	96-98	60 <b>(80)</b>	7051 <b>(15,548)</b>	4721 <b>(15'6")</b>	0.96 <b>(1.25)</b>	0.96 <b>(1.25)</b>
(AWS) 426C	1CR864 and up (1ER864 and up)	99-00	63 <b>(85)</b>	7051 <b>(15,548)</b>	4721 <b>(15'6")</b>	0.96 <b>(1.25)</b>	0.96 <b>(1.25)</b>
426C (IT)	1YR(1ZR)	96-98	60 <b>(80)</b>	7387 <b>(16,289)</b>	4721 <b>(15'6")</b>	0.96 <b>(1.25)</b>	0.96 <b>(1.25)</b>
426C (IT)	1YR1517 and up (1ZR926 and up)	99-00	63 <b>(85)</b>	7387 <b>(16,289)</b>	4721 <b>(15'6")</b>	0.96 <b>(1.25)</b>	0.96 <b>(1.25)</b>
(AWS) 426C (IT)	1MR(1NR)	96-98	60 <b>(80)</b>	7387 <b>(16,289)</b>	4721 <b>(15'6")</b>	0.96 <b>(1.25)</b>	0.96 <b>(1.25)</b>
(AWS) 426C (IT)	1MR956 and up (1NR954 and up)	99-00	63 <b>(85)</b>	7387 <b>(16,289)</b>	4721 <b>(15'6")</b>	0.96 <b>(1.25)</b>	0.96 <b>(1.25)</b>

## Backhoe Loaders (cont'd)

Model	Product Ident. No. Prefix	Years Built	Flywheel Horsepower kW (hp)	Operating Weight kg (lb)	Digging Depth mm (ft/in)	GP Bucket Capacity m <sup>3</sup> (yd <sup>3</sup> )	MP Bucket Capacity m <sup>3</sup> (yd <sup>3</sup> )
428	6TC	86-90	52 (70)	6963 (15,350)	4790 (15'9")	1.0 (1.31)	0.92 (1.2)
428 Series II	6TC	90-92	52 (70)	7143 (15,750)	4750 (15'7")	1.0 (1.31)	0.92 (1.2)
428B	7EJ	92-95	60 (80)	7254 (15,992)	4810 (15'9")	1.0 (1.31)	0.92 (1.2)
428C	8RN	96-00	56 (75)	7279 (16,047)	4811 (15'9")	1.0 (1.31)	1.03 (1.35)
428C (IT)	2CR	96-00	56 (75)	7615 (16,788)	4811 (15'9")	1.0 (1.31)	1.03 (1.35)
428D	DSX, BXC, MBM	01-05	61 (82)	7738 (17,059)	4854 (15'9")	1.0 (1.31)	1.03 (1.35)
430D	BNK	00-05	75 (101)	7355 (16,217)	4639 (15'3")	1.0 (1.31)	0.96 (1.25)
430D (IT)	BML	00-05	75 (101)	7355 (16,217)	4639 (15'3")	1.0 (1.31)	0.96 (1.25)
432D	TDR, WEP	01-05	69 (93)	7809 (17,216)	4854 (15'9")	1.0 (1.31)	1.03 (1.35)
436	5KF	88-90	57 (77)	6831 (15,062)	4960 (16'3")	0.76 (1.0)	0.76 (1.0)
436 Series II	5KF	90-92	57 (77)	6878 (15,166)	4950 (16'3")	0.76 (1.0)	0.76 (1.0)
436B	7FL(6MJ)	92-95	63 (84)	6857 (15,086)	4950 (16'3")	0.96 (1.25)	0.96 (1.25)
436C	8TN(9JN)	96-98	63 (85)	7118 (15,694)	4953 (16'3")	1.0 (1.31)	0.96 (1.25)
436C	8TN925 and up (9JN884 and up)	99-00	70 (93)	7118 (15,694)	4953 (16'3")	1.0 (1.31)	0.96 (1.25)
(AWS) 436C	1FR(1GR)	96-98	63 (85)	7118 (15,694)	4953 (16'3")	1.0 (1.31)	0.96 (1.25)
(AWS) 436C	1FR1416 and up (1GR916 and up)	99-00	70 (93)	7118 (15,694)	4953 (16'3")	1.0 (1.31)	0.96 (1.25)
436C (IT)	2AR(2BR)	96-98	63 (85)	7454 (16,435)	4953 (16'3")	1.0 (1.31)	0.96 (1.25)
436C (IT)	2AR1604 and up (2BR911 and up)	99-00	70 (93)	7454 (16,435)	4953 (16'3")	1.0 (1.31)	0.96 (1.25)
(AWS) 436C (IT)	1PR(1RR)	96-98	63 (85)	7454 (16,435)	4953 (16'3")	1.0 (1.31)	0.96 (1.25)
(AWS) 436C (IT)	1PR1599 and up (1RR998 and up)	99-00	70 (93)	7454 (16,435)	4953 (16'3")	1.0 (1.31)	0.96 (1.25)

**Backhoe Loaders (cont'd)**

Model	Product Ident. No. Prefix	Years Built	Flywheel Horsepower kW (hp)	Operating Weight kg (lb)	Digging Depth mm (ft/in)	GP Bucket Capacity m <sup>3</sup> (yd <sup>3</sup> )	MP Bucket Capacity m <sup>3</sup> (yd <sup>3</sup> )
438	3DJ	88-90	63 <b>(84)</b>	7900 <b>(17,420)</b>	4810 <b>(15'9")</b>	1.0 <b>(1.31)</b>	0.92 <b>(1.2)</b>
438 Series II	3DJ	90-92	57 <b>(77)</b>	7364 <b>(16,237)</b>	4810 <b>(15'9")</b>	1.0 <b>(1.31)</b>	0.92 <b>(1.2)</b>
438B	3KK	92-95	62.7 <b>(84)</b>	8331 <b>(18,367)</b>	4870 <b>(16'0")</b>	1.0 <b>(1.31)</b>	0.92 <b>(1.2)</b>
438C	9KN	96-98	63 <b>(85)</b>	7384 <b>(16,279)</b>	4873 <b>(16'0")</b>	1.0 <b>(1.31)</b>	1.03 <b>(1.35)</b>
438C	9KN1061 and up	99-00	70 <b>(93)</b>	7384 <b>(16,279)</b>	4873 <b>(16'0")</b>	1.0 <b>(1.31)</b>	1.03 <b>(1.35)</b>
(AWS) 438C	1JR	96-98	63 <b>(85)</b>	7384 <b>(16,279)</b>	4873 <b>(16'0")</b>	1.0 <b>(1.31)</b>	1.03 <b>(1.35)</b>
(AWS) 438C	1JR1107 and up	99-00	70 <b>(93)</b>	7384 <b>(16,279)</b>	4873 <b>(16'0")</b>	1.0 <b>(1.31)</b>	1.03 <b>(1.35)</b>
438C (IT)	2DR	96-98	63 <b>(85)</b>	7720 <b>(17,020)</b>	4873 <b>(16'0")</b>	1.0 <b>(1.31)</b>	1.03 <b>(1.35)</b>
438C (IT)	2DR2717 and up	99-00	70 <b>(93)</b>	7720 <b>(17,020)</b>	4873 <b>(16'0")</b>	1.0 <b>(1.31)</b>	1.03 <b>(1.35)</b>
(AWS) 438C (IT)	1TR	96-98	63 <b>(85)</b>	7720 <b>(17,020)</b>	4873 <b>(16'0")</b>	1.0 <b>(1.31)</b>	1.03 <b>(1.35)</b>
(AWS) 438C (IT)	1TR1284 and up	99-00	70 <b>(93)</b>	7720 <b>(17,020)</b>	4873 <b>(16'0")</b>	1.0 <b>(1.31)</b>	1.03 <b>(1.35)</b>
442D	SMJ, TBD	01-05	75 <b>(101)</b>	7809 <b>(17,216)</b>	4854 <b>(15'9")</b>	1.0 <b>(1.31)</b>	1.03 <b>(1.35)</b>
446	6XF	89-95	71 <b>(95)</b>	8892 <b>(19,603)</b>	5220 <b>(17'2")</b>	1.15 <b>(1.5)</b>	1.10 <b>(1.5)</b>
446B			76 <b>(102)</b>	8890 <b>(19,600)</b>	5220 <b>(17'2")</b>	1.15 <b>(1.5)</b>	1.05 <b>(1.375)</b>
446D	DBL	04-06	76 <b>(102)</b>	8939 <b>(19,666)</b>	5142 <b>(16'10")</b>	1.15 <b>(1.5)</b>	1.25 <b>(1.63)</b>



## PIPELAYERS

Model	Tractor Product Ident. No. Prefix	Years Built	Engine HP	Approx. Weight kg (lb)	Counter-weight kg (lb)	Max. Lift Capacity 1.2 m (4'0") Overhang kg (lb)	Speed Range km/h (mph)		Ground Clearance mm (in)	Ground Contact m <sup>2</sup> (in <sup>2</sup> )
							Forward	Reverse		
MD6	9U39C	52-57	93	12 375 (27,820)	1590 (3500)	12 035 (26,530)	2.7–10.6 (1.7–6.6)	3.2–10.0 (2.0–6.2)	321 (13)	1.77 (2744)
561B	62A	59-66	90	14 560 (32,100)	2270 (5000)	17 500 (38,800)	2.7–10.6 (1.7–6.6)	1.8–9.9 (2.0–6.2)	267 (11)	2.02 (3130)
561B	62A	66-67	93	14 350 (31,637)	2270 (5000)	17 600 (38,800)	2.7–10.9 (1.7–6.8)	3.4–10.3 (2.1–6.4)	267 (11)	2.02 (3130)
561C	85H	66-67	93	14 700 (32,500)	2450 (5400)	18 000 (40,000)	2.7–11.1 (1.7–6.9)	3.4–10.1 (2.1–6.3)	395 (16)	2.02 (3130)
561C	92J	67-77	105	14 700 (32,500)	2450 (5400)	18 100 (40,000)	2.7–11.1 (1.7–6.9)	3.4–10.1 (2.1–6.3)	395 (16)	2.02 (3130)
561D	54X	78-89	105	15 800 (35,000)	2990 (6600)	18 100 (40,000)	3.5–10.1 (2.2–6.3)	4.2–12.2 (2.6–7.6)	395 (16)	2.02 (3130)
561H	6NL	93-97	105	15 700 (34,600)	2128 (4690)	18 100 (40,000)	3.4–10.2 (2.1–6.4)	4.1–12.4 (2.6–7.7)	363 (14.3)	2.67 (4120)
561M		01	110	16 240 (35,800)	3260 (7200)	18 100 (40,000)	3.3–9.9 (2.0–6.2)	4.0–12.1 (2.5–7.5)	438 (17.2)	2.67 (4120)
561M CB* (US)	1KW	97-02	110	16 240 (35,800)						
561N	CPH	03-08	123	16 851 (37,150)	3270 (7210)	18 145 (40,000)	3.1–9.1 (1.9–5.6)	3.8–11.3 (2.3–6.9)	422 (16.6)	2.93 (4542)
561N	TAD	03-08	123	16 851 (37,150)	3270 (7210)	18 145 (40,000)	3.1–9.1 (1.9–5.6)	3.8–11.3 (2.3–6.9)	422 (16.6)	2.93 (4542)
571E PS	64A	61-67	160	22 680 (50,000)	2360 (5200)	7 490 (60,600)	3.7–10.3 (2.3–6.4)	4.3–12.1 (2.7–7.5)	400 (16)	3.04 (4710)
571E PS	64A	66-72	180	23 100 (51,000)	2360 (5200)	27 500 (60,600)	3.7–10.1 (2.3–6.3)	4.3–11.9 (2.7–7.4)	400 (16)	3.04 (4710)
571F	95N	72-74	180	22 800 (50,300)	4350 (9600)	27 500 (60,600)	3.5–9.7 (2.2–6.0)	4.2–11.4 (2.6–7.1)	400 (16)	3.04 (4710)
571G	16W	75-81	200	23 040	4350	27 500	3.7–10.0	4.5–11.9	399	3.04
	52D(JPN)	87-96	200	(50,800)	(9600)	(60,600)	(2.3–6.2)	(2.8–7.9)	(15.7)	(4710)
MD7	17A	51-57	140	16 200 (35,815)	3400 (7500)	24 585 (54,200)	2.4–9.5 (1.5–5.9)	2.9–8.7 (1.8–5.4)	394 (16)	3.12 (4840)

\*Gauge 2.0 m (6'7"), Width 3.19 m (10'5"), Length 3.73 m (12'3"), Height 3.12 m (10'3"), PS Transmission.

Forward Speed: 1st gear 3.27 km/h (2.03 mph)

2nd gear 5.81 km/h (3.61 mph)

3rd gear 9.93 km/h (6.17 mph)

## Pipelayers (cont'd)

Model	Tractor Product Ident. No. Prefix	Years Built	Engine HP	Approx. Weight kg (lb)	Counterweight kg (lb)	Max. Lift Capacity 1.2 m (4'0") Overhang kg (lb)	Speed Range km/h (mph)		Ground Clearance mm (in)	Ground Contact m <sup>2</sup> (in <sup>2</sup> )
							Forward	Reverse		
572C	21A	57-61	128	26 200 <b>(57,820)</b>	4720 <b>(10,405)</b>	39 000 <b>(86,000)</b>	3.2–7.7 <b>(2.0–4.8)</b>	3.9–6.1 <b>(2.4–3.8)</b>	483 <b>(19)</b>	3.30 <b>(5109)</b>
572D	21A	59	140	26 500 <b>(58,520)</b>	4940 <b>(10,900)</b>	39 000 <b>(86,000)</b>	4.2–9.7 <b>(2.6–6.0)</b>	4.8–7.7 <b>(3.0–4.8)</b>	483 <b>(19)</b>	3.30 <b>(5109)</b>
572E PS	65A	61-69	180	28 000 <b>(62,000)</b>	6000 <b>(13,000)</b>	40 800 <b>(90,000)</b>	3.7–10.1 <b>(2.3–6.3)</b>	4.3–11.9 <b>(2.7–7.4)</b>	480 <b>(19)</b>	3.45 <b>(5345)</b>
572F PS	96N	70-74	180	27 600 <b>(61,000)</b>	6440 <b>(14,200)</b>	40 800 <b>(90,000)</b>	3.5–9.7 <b>(2.2–6.0)</b>	4.2–11.4 <b>(2.6–7.1)</b>	480 <b>(19)</b>	3.45 <b>(5345)</b>
572G	40U	75-86	200	27 800 <b>(61,300)</b>	6400 <b>(14,200)</b>	40 800 <b>(90,000)</b>	3.7–10.0 <b>(2.3–6.2)</b>	4.5–11.9 <b>(2.8–7.4)</b>	480 <b>(19)</b>	3.45 <b>(5345)</b>
572G	8PC	84-89	200	27 800 <b>(61,300)</b>	6400 <b>(14,200)</b>	40 800 <b>(90,000)</b>	3.7–10.0 <b>(2.3–6.2)</b>	4.5–11.9 <b>(2.8–7.4)</b>	480 <b>(19)</b>	3.45 <b>(5345)</b>
572R	2HZ	98-04	230	30 110 <b>(66,250)</b>	5055 <b>(11,150)</b>	40 825 <b>(90,000)</b>	3.5–11.1 <b>(2.3–6.9)</b>	4.8–14.2 <b>(3.0–8.8)</b>	414 <b>(16.3)</b>	4.19 <b>(6500)</b>
578	8HB	89-97	300	46 580 <b>(102,690)</b>	11 777 <b>(25,963)</b>	70 307 <b>(155,000)</b>	3.8–10.8 <b>(2.35–6.7)</b>	4.7–13.8 <b>(2.9–8.6)</b>	452 <b>(17.8)</b>	5.17 <b>(8020)</b>
583C	16A	55-58	190	35 440 <b>(78,132)</b>	8470 <b>(18,676)</b>	58 970 <b>(130,000)</b>	3.9–8.7 <b>(2.4–5.4)</b>	3.9–8.7 <b>(2.4–5.4)</b>	533 <b>(21)</b>	4.24 <b>(6580)</b>
583HTC	38A	59-60	235	38 000 <b>(83,840)</b>	9030 <b>(19,900)</b>	62 140 <b>(137,000)</b>	4.5–10.3 <b>(2.8–6.4)</b>	4.5–10.3 <b>(2.8–6.4)</b>	537 <b>(22)</b>	4.66 <b>(7220)</b>
583H PS	61A	60-74	191	35 600 <b>(78,500)</b>	8470 <b>(18,676)</b>	58 970 <b>(130,000)</b>	3.9–8.7 <b>(2.4–5.4)</b>	3.9–8.7 <b>(2.4–5.4)</b>	533 <b>(21)</b>	4.55 <b>(7050)</b>
583H PS	61A	60-67	225	38 200 <b>(84,270)</b>	9000 <b>(19,900)</b>	62 140 <b>(137,000)</b>	4.1–11.1 <b>(2.5–6.9)</b>	4.6–12.8 <b>(8.9–8.0)</b>	537 <b>(22)</b>	4.66 <b>(7220)</b>
583H PS	61A	61	235	38 900 <b>(85,720)</b>	10 400 <b>(22,880)</b>	62 140 <b>(137,000)</b>	3.9–10.1 <b>(2.4–6.3)</b>	4.8–12.6 <b>(3.0–7.8)</b>	537 <b>(22)</b>	4.66 <b>(7220)</b>
583H	61A	74	270	40 600 <b>(89,500)</b>	10 300 <b>(22,700)</b>	63 500 <b>(140,000)</b>	3.9–10.5 <b>(2.4–6.5)</b>	4.8–13.0 <b>(3.0–8.1)</b>	533 <b>(21)</b>	4.65 <b>(7220)</b>
583K	78V	74-89	300	40 960 <b>(90,300)</b>	7840 <b>(17,290)</b>	63 500 <b>(140,000)</b>	4.0–10.9 <b>(2.5–6.8)</b>	5.0–13.5 <b>(3.1–8.4)</b>	530 <b>(21)</b>	4.65 <b>(7220)</b>
583R	2XS	98-05	228 kW <b>(305)</b>	44 748 <b>(98,650)</b>	9036 <b>(19,920)</b>	63 504 <b>(140,000)</b>	3.5–10.8 <b>(2.3–6.8)</b>	4.7–3.8 <b>(2.9–8.6)</b>	537 <b>(21.1)</b>	5.10 <b>(7896)</b>
583T	CMX	06-11	231 kW <b>(310)</b>	45 359 <b>(100,000)</b>	9036 <b>(19,920)</b>	63 504 <b>(140,000)</b>	3.5-10.8 <b>(2.3-6.8)</b>	4.7-13.8 <b>(2.9-8.6)</b>	470 <b>(18.5)</b>	5.10 <b>(7896)</b>
587R	BXL	06-11	273 kW <b>(366)</b>	53 070 <b>(117,000)</b>	12 900 <b>(28,440)</b>	91 625 <b>(202,000)</b>	3.2-10.0 <b>(2.0-6.2)</b>	4.3-12.9 <b>(2.7-8.0)</b>	457 <b>(18)</b>	6.2 <b>(9613)</b>
587T	FAT	06-11	262 kW <b>(351)</b>	53 442 <b>(117,820)</b>	12 900 <b>(28,440)</b>	91 625 <b>(202,000)</b>	3.2-9.7 <b>(2.0-6.0)</b>	4.3-12.6 <b>(2.7-7.8)</b>	457 <b>(18)</b>	6.2 <b>(9613)</b>
589	31Z	82-06	313 kW <b>(420)</b>	65 366 <b>(151,212)</b>	11 854 <b>(26,134)</b>	104 330 <b>(230,000)</b>	3.5–10.9 <b>(2.2–6.8)</b>	4.3–13.7 <b>(2.7–8.5)</b>	625 <b>(24.6)</b>	6.96 <b>(12,148)</b>
594	62H	74	385	55 400 <b>(122,000)</b>	12 600 <b>(27,800)</b>	90 700 <b>(200,000)</b>	3.9–10.5 <b>(2.4–6.5)</b>	4.8–12.7 <b>(3.0–7.9)</b>	640 <b>(25)</b>	5.72 <b>(8865)</b>
594H	96V	74-82	410	56 065 <b>(123,600)</b>	12 555 <b>(27,680)</b>	90 700 <b>(200,000)</b>	4.0–10.8 <b>(2.5–6.7)</b>	5.0–13.2 <b>(3.1–8.2)</b>	630 <b>(25)</b>	6.48 <b>(10,050)</b>





## WHEEL TRACTOR-SCRAPERS

Model	Product Ident. No. Prefix	Years Built	Horse-power Max/ Rated	Capacity Struck/ Heaped m <sup>3</sup> (yd <sup>3</sup> )	Approx. Shipping Weight kg (lb)	Dimensions m (ft)				Tire Size (Standard) & ply rating Tractor & Scraper	Turning Circle m (ft)
						Length	Width	Height	Width of Tread		
DW10 Tractor	1N	41-46	100/*	—	6550	4.57	2.24	1.93	1.73	10.0 × 20-12	—
					<b>(14,350)</b>	<b>(15'0")</b>	<b>(7'4")</b>	<b>(6'4")</b>	<b>(5'8")</b>	18.0 × 24-16	
DW10 Tractor	6V	46-47	100/*	—	6850	4.57	2.24	1.93	1.73	10.0 × 20-12	—
					<b>(15,100)</b>	<b>(15'0")</b>	<b>(7'4")</b>	<b>(6'4")</b>	<b>(5'8")</b>	18.0 × 24-16	
DW10 Tractor	1V	47-53	115/*	—	7540	4.70	2.34	1.93	1.79	12.0 × 20-14	—
					<b>(16,610)</b>	<b>(15'5")</b>	<b>(7'8")</b>	<b>(6'4")</b>	<b>(5'10")</b>	21.0 × 25-20	
DW10 & No. 10 Scraper	1V 3C	47-51	115/*	6.7/8.4	15 980	11.23	3.02	2.69	1.88	12.0 × 20-14	7.92
				<b>(8.7/11)</b>	<b>(35,240)</b>	<b>(37'0")</b>	<b>(9'11")</b>	<b>(8'10")</b>	<b>(6'2")</b>	21.0 × 25-20	<b>(26'0")</b>
DW10 & No. 10 Scraper	1V 19C	52-53	115/*	5.3/6.9	15 130	10.72	2.87	2.36	1.80	12.0 × 20-14	11.23
				<b>(7/9)</b>	<b>(33,365)</b>	<b>(35'2")</b>	<b>(9'5")</b>	<b>(7'9")</b>	<b>(5'11")</b>	21.0 × 25-20	<b>(37'0")</b>
									Scraper	16.0 × 21-20	
DW15 & No. 10 Scraper	45C 19C	54-55	/150	5.3/6.9	15 960	11.10	2.87	2.36	1.80	12.0 × 20-14	10.36
				<b>(7/9)</b>	<b>(35,180)</b>	<b>(36'5")</b>	<b>(9'5")</b>	<b>(7'9")</b>	<b>(5'11")</b>	21.0 × 25-20	<b>(34'0")</b>
									Scraper	16.0 × 21-20	
DW15 & No. 15 Scraper	45C 4W	54-55	/150	7.7/9.2	9400	11.84	3.18	2.69	1.93	12.0 × 20-14	11.23
				<b>(10/12)</b>	<b>(20,720)</b>	<b>(38'10")</b>	<b>(10'5")</b>	<b>(8'10")</b>	<b>(6'4")</b>	21.0 × 25-20	<b>(37'0")</b>
DW15 Tractor	45C	54-55	/150	—	9510	5.08	2.39	2.69	1.98	12.0 × 20-14	—
					<b>(20,960)</b>	<b>(16'8")</b>	<b>(7'10")</b>	<b>(8'10")</b>	<b>(6'6")</b>	21.0 × 25-20	
DW15C & No. 15 Scraper	59C or 70C	55-57	186/*	7.7/9.5	19 220	11.84	3.18	2.69	1.98	12.0 × 12-14	10.36
				<b>(10/12.5)</b>	<b>(42,370)</b>	<b>(38'10")</b>	<b>(10'5")</b>	<b>(8'10")</b>	<b>(6'6")</b>	21.0 × 25-20	<b>(34'0")</b>
DW15E & No. 428 Scraper	75D or 76D	57-59	200/172	10/14	20 280	12.22	3.30	3.05	1.98	12.0 × 20-14	—
				<b>(13/18)</b>	<b>(44,711)</b>	<b>(40'1")</b>	<b>(10'10")</b>	<b>(10'0")</b>	<b>(6'6")</b>	26.5 × 25-20	
DW15F & No. 428 Scraper	75D or 76D	58-59	200/172	10/14	20 280	12.22	3.30	3.05	1.98	12.0 × 20-14	—
				<b>(13/18)</b>	<b>(44,711)</b>	<b>(40'1")</b>	<b>(10'10")</b>	<b>(10'0")</b>	<b>(6'6")</b>	26.5 × 25-20	
DW20 & No. 20 Scraper	21C 11C	51-55	225/*	14/7.6	12 750	13.23	3.53	3.10	2.29	24.0 × 29-4	11.23
				<b>(18/23)</b>	<b>(28,100)</b>	<b>(43'5")</b>	<b>(11'7")</b>	<b>(10'2")</b>	<b>(7'6")</b>		<b>(37'0")</b>
DW20 Tractor (For W20 Wagon)	6W	51-55	225/*	—	11 620	5.39	2.79	2.41	2.18	14.0 × 24-16	—
					<b>(25,610)</b>	<b>(17'8")</b>	<b>(9'2")</b>	<b>(7'11")</b>	<b>(7'2")</b>	24.0 × 29-24	
DW20E & No. 456 Scraper	57C 67C	55-57	300/*	14/19	26 040	13.36	3.58	3.45	2.24	14.0 × 24-16	11.58
				<b>(18/25)</b>	<b>(57,400)</b>	<b>(43'10")</b>	<b>(11'9")</b>	<b>(11'4")</b>	<b>(7'4")</b>	29.5 × 29-22	<b>(38'0")</b>
DW20F & No. 456 Scraper	87E 88E	58-60	320/*	14/19	26 870	13.36	3.58	3.45	2.24	14.0 × 24-16	11.58
				<b>(18/25)</b>	<b>(59,240)</b>	<b>(43'10")</b>	<b>(11'9")</b>	<b>(11'4")</b>	<b>(7'4")</b>	29.5 × 29-22	<b>(38'0")</b>
DW20G & No. 456 Scraper	87E 88E	58-60	345/*	15/21	27 200	13.36	3.58	3.45	2.24	14.0 × 24-16	11.58
				<b>(19.5/27)</b>	<b>(59,960)</b>	<b>(43'10")</b>	<b>(11'9")</b>	<b>(11'4")</b>	<b>(7'4")</b>	29.5 × 29-28	<b>(38'0")</b>
DW20G & No. 482 Scraper	87E 88E	58-60	345/*	18.5/26	31 070	14.05	3.91	3.81	2.39	14.0 × 24-16	11.58
				<b>(24/34)</b>	<b>(68,500)</b>	<b>(46'1")</b>	<b>(12'10")</b>	<b>(12'6")</b>	<b>(7'10")</b>	29.5 × 29-28	<b>(38'0")</b>

\*Maximum HP only available.

## Wheel Tractor-Scrapers (cont'd)

Model	Product Ident. No. Prefix	Years Built	Horse-power Max/ Rated	Capacity Struck/ Heaped m <sup>3</sup> (yd <sup>3</sup> )	Approx. Shipping Weight kg (lb)	Dimensions m (ft)				Tire Size (Standard) & ply rating Tractor & Scraper	Turning Circle m (ft)
						Length	Width	Height	Width of Tread		
DW21 & No. 21 Scraper	8W	51-55	225/*	11.5/15 (15/20)	24 790 (54,650)	12.37 (40'7")	3.53 (11'7")	3.28 (10'9")	2.13 (7'0")	24.0 × 29-24	10.67 (35'0")
DW21C & No. 470 Scraper	58C	55-58	300/*	14/19 (18/25)	26 610 (58,670)	12.67 (41'7")	3.58 (11'9")	3.35 (11'0")	2.24 (7'4")	29.5 × 29-22	11.00 (36'0")
DW21D & No. 470 Scraper	69C	58-58	320/*	14/19 (18/25)	26 310 (58,010)	12.78 (41'11")	3.58 (11'9")	3.35 (11'0")	2.24 (7'4")	29.5 × 29-22	11.00 (36'0")
DW21G & No. 470 Scraper	85E	58-60	345/*	14.9/20.6 (19.5/27)	27 210 (59,980)	12.78 (41'11")	3.58 (11'9")	3.48 (11'5")	2.24 (7'4")	29.5 × 29-28	11.00 (36'0")
611	6SZ	99-03	265	11 (15)	23 900 (52,640)	12.02 (39'5")	3.27 (10'9")	3.24 (10'8")	2.06 (6'9")	29.5R25	10.2 (33'5")
613A	71M	69-76	/150	8.4 (11)	13 334 (29,395)	9.67 (31'9")	2.44 (8'0")	2.85 (9'4.5")	1.89 (6'2.5")	18.0 × 25-12	9.04 (29'8")
613B	38W	76-84	/150	8.4 (11)	14 155 (31,210)	9.78 (32'1")	2.44 (8'0")	2.85 (9'4.5")	1.89 (6'2.5")	18.0 × 25-12	8.94 (29'4")
613C		84-93	175	8.4 (11)	14 670 (32,340)	10.0 (32'9")	2.44 (8'0")	3.06 (10'0")	1.89 (6'2.5")	18.00-25, 16 PR (E-2)	8.9 (29'4")
613C Series II	8LJ	93-08	175	6.8/8.4 (8.9/11)	15 264 (33,650)	10.14 (33'3")	2.44 (8'0")	3.01 (9'10")	1.80 (5'11")	23.5R25★	9.0 (29'6")
613G	ESB	08-10	181	6.8/8.4 (8.9/11)	16 887 (37,229)	10.41 (34'2")	2.43 (8'0")	3.01 (9'11")	1.80 (5'11")	23.5R25★	9.0 (29'6")
615	46Z	81-87	/250	12.23 (16)	23 400 (51,590)	11.6 (38'1")	3.048 (10'0")	3.590 (11'8")	2.21 (7'3")	26.5-25, 26 PR (E-2)	9.63 (31'7")
615C		87-93	265	12.23 (16)	23 860 (52,600)	11.6 (38'1")	3.048 (10'0")	3.59 (11'9")	2.21 (7'3")	26.5-25, 26 PR (E-2)	9.63 (31'7")
615C Series II	9XG	93-08	265	11/13 (14/17)	25 605 (56,450)	11.6 (38'1")	3.05 (10'0")	3.5 (11'0")	2.1 (6'9")	29.5R25★	10.8 (35'6")
619B DD	89E	59-60	/225							Turbocharged, Electric start	
DD	90E									Turbocharged, Gas start	
619C PS	61F	60-66	280/250	10.8/14 (14/18)	21 550 (47,500)	11.05 (36'3")	3.30 (10'11")	3.76 (12'2")	2.00 (6'7")	26.5 × 29-22	9.14 (30'0")
DD	62F										
619**	43F	64-65	/250	15.3/12.6 (20/16.5)	27 400 (60,390)	11.89 (40'0")	3.60 (11'10")	3.45 (11'4")	2.30 (7'7")	26.5 × 29-26	10.20 (33'6")
621	43H	65-72	/300	10.7/15.3 (14/20)	28 400 (62,600)	12.00 (39'5")	3.60 (11'10")	3.45 (11'4")	2.19 (7'3")	29.5 × 29-22	11.50 (37'8")
621	23H	65-74	/300	10.7/15.3 (14/20)	24 900 (55,000)	11.60 (38'1")	3.50 (11'7")	3.40 (11'2")	2.10 (6'10")	29.5 × 29-22	13.00 (42'6")
621B	45P	73-86	/330	10.7/15.3 (14/20)	30 205 (66,590)	12.7 (41'7")	3.45 (11'4")	3.63 (11'11")	2.21 (7'3")	29.5-29, 28 PR (E-3)	11.10 (36'6")
621E	6AB	86-93	/330	10.7/15.3 (14/20)	30 480 (67,195)	12.93 (42'5")	3.47 (11'4")	3.71 (12'2")	2.21 (7'3")	33.25-29, 26 PR (E-3)	10.9 (35'8")
	2PD										

\*Maximum HP only available.

\*\*Johnson Manufacturing Company built the J619 Elevating Scraper for Caterpillar in 1964.

Wheel Tractor-Scrapers (cont'd)

Model	Product Ident. No. Prefix	Years Built	Horse-power Max/ Rated	Capacity Struck/ Heaped m <sup>3</sup> (yd <sup>3</sup> )	Approx. Shipping Weight kg (lb)	Dimensions m (ft)				Tire Size (Standard) & ply rating Tractor & Scraper	Turning Circle m (ft)
						Length	Width	Height	Width of Tread		
621F	4SK	93-00	330	10.7/15.3 <b>(14/20)</b>	32 090 <b>(70,740)</b>	12.93 <b>(42'5")</b>	3.47 <b>(11'4")</b>	3.71 <b>(12'2")</b>	2.21 <b>(7'3")</b>	33.25-29 ★★ (E-2/E-3)	10.2 <b>(33'5")</b>
621G	ALP	00-03	330/365	10.7/15.3 <b>(14/20)</b>	32 250 <b>(71,090)</b>	12.93 <b>(42'5")</b>	3.47 <b>(11'4")</b>	3.71 <b>(12'2")</b>	2.20 <b>(7'3")</b>	33.25R29	11.7 <b>(38'5")</b>
621G	CEN	03-05	330/365	12/17 <b>(15.7/22)</b>	32 563 <b>(71,790)</b>	12.93 <b>(42'5")</b>	3.47 <b>(11'4")</b>	3.71 <b>(12'2")</b>	2.20 <b>(7'3")</b>	33.25R29	11.7 <b>(38'5")</b>
621G	DBB	05-10	330/365	12/17 <b>(15.7/22)</b>	33 995 <b>(74,946)</b>	12.88 <b>(42'3")</b>	3.58 <b>(11'9")</b>	3.71 <b>(12'3")</b>	2.23 <b>(7'4")</b>	33.25R29 ★★ (E-3)	11.7 <b>(38'5")</b>
621H	DBK EAZ	10-13	407	13/18.4 <b>(17.1/24)</b>	36 185 <b>(79,787)</b>	14.02 <b>(45'10")</b>	3.57 <b>(11'7")</b>	4.03 <b>(13'2")</b>	2.29 <b>(7'5")</b>	33.25R29 ★★ (E-3)	11.8 <b>(38'7")</b>
623	52U	72-74	/300	16.8 <b>(22)</b>	29 900 <b>(66,000)</b>	11.90 <b>(39'0")</b>	3.50 <b>(11'7")</b>	3.70 <b>(12'1")</b>	2.20 <b>(7'3")</b>	29.5 × 29-28	13.70 <b>(44'11")</b>
623B	46P	73-86	/330	16.8 <b>(22)</b>	32 546 <b>(71,750)</b>	12.5 <b>(41'1")</b>	3.55 <b>(11'8")</b>	3.81 <b>(12'6")</b>	2.18 <b>(7'2")</b>	29.5-29, 28 PR (E-2)	8.90 <b>(29'4")</b>
623E	6CB	86-89	/330	16.8 <b>(22)</b>	33 317 <b>(73,450)</b>	12.61 <b>(41'4")</b>	3.55 <b>(11'8")</b>	3.81 <b>(12'6")</b>	2.21 <b>(7'3")</b>	29.5-29, 34 PR (E-2)	10.9 <b>(35'9")</b>
623E	6YF	89-93	/365	13.8/17.6 <b>(18/23)</b>	35 290 <b>(77,800)</b>	12.61 <b>(41'4")</b>	3.55 <b>(11'8")</b>	3.94 <b>(12'11")</b>	2.18 <b>(7'2")</b>	29.5R25	10.9 <b>(35'8")</b>
623F	6BK	93-98	365	13.8/17.6 <b>(18/23)</b>	35 305 <b>(77,830)</b>	12.61 <b>(41'4")</b>	3.55 <b>(11'8")</b>	3.94 <b>(12'11")</b>	2.18 <b>(7'2")</b>	29.5-29, 34 PR (E-2)	10.9 <b>(35'8")</b>
623F Series II	5EW	98-00	365	13.8/17.6 <b>(18/23)</b>	37 122 <b>(81,840)</b>	13.28 <b>(43'7")</b>	3.55 <b>(11'8")</b>	3.55 <b>(11'8")</b>	2.21 <b>(7'3")</b>	33.25-R29 ★★ (E-2)	8.6 <b>(28'5")</b>
623G	ARW	00-02	330/365	13.8/17.6 <b>(18/23)</b>	37 120 <b>(81,840)</b>	13.21 <b>(43'4")</b>	3.55 <b>(11'8")</b>	3.68 <b>(12'1")</b>	2.2 <b>(7'3")</b>	33.25R29	10.9 <b>(35'8")</b>
623G	CES	03-05	330/365	13.8/17.6 <b>(18/23)</b>	37 120 <b>(81,840)</b>	13.21 <b>(43'4")</b>	3.55 <b>(11'8")</b>	3.68 <b>(12'1")</b>	2.2 <b>(7'3")</b>	33.25R29	10.9 <b>(35'8")</b>
623G	DBC	05-10	330/365	13.8/17.6 <b>(18/23)</b>	37 510 <b>(82,695)</b>	13.17 <b>(43'2")</b>	3.58 <b>(11'9")</b>	3.71 <b>(12'3")</b>	2.23 <b>(7'4")</b>	33.25R29 ★★ (E-3)	12.0 <b>(39'4")</b>
623H	DBF EJD	10-13	407	14.4/17.6 <b>(18.8/23)</b>	39 937 <b>(88,061)</b>	13.77 <b>(45'2")</b>	3.57 <b>(11'7")</b>	3.77 <b>(12'3")</b>	2.29 <b>(7'5")</b>	33.25R29 ★★ (E-3)	11.8 <b>(38'7")</b>

Wheel Tractor-Scrapers (cont'd)

Model	Product Ident. No. Prefix	Years Built	Horse-power Max/ Rated	Capacity Struck/ Heaped m <sup>3</sup> (yd <sup>3</sup> )	Approx. Shipping Weight kg (lb)	Dimensions m (ft)				Tire Size (Standard) & ply rating Tractor & Scraper	Turning Circle m (ft)
						Length	Width	Height	Width of Tread		
627	54K	68-74	T/225	10.7/15.3	29 900	12.00	3.50	3.60	2.20	29.5 × 29-28	13.30
			S/225	(14/20)	(66,000)	(36'9")	(11'7")	(11'8")	(7'3")		(43'9")
627B	14S	73-86	T/225	10.7/15.3	34 610	13.3	3.45	3.63	2.18	29.5-29,	11.10
			S/225	(14/20)	(76,300)	(43'9")	(11'4")	(11'11")	(7'2")	28 PR (E-3)	(36'6")
627E	6EB	86-90	T/225	10.7/15.3	34 670	12.89	3.47	3.71	2.21 (7'3")	33.25-29,	10.90
			S/225	(14/20)	(76,435)	(42'3")	(11'4")	(12'2")	2.18 (7'2")	26 PR (E-3)	(35'9")
627E	7CG	90-93	T/330	10.7/15.3	35 160	12.93	3.47	3.71	2.21	33.25-29,	10.9
			S/225	(14/20)	(77,500)	(42'5")	(11'4")	(12'2")	(7'3")	26 PR (E-3)	(35'8")
627F Series II	1DL	93-00	T/330	10.7/15.3	37 060	12.9	3.47	3.71	2.21	33.25-R29	10.9
			S/225	(14/20)	(81,640)	(42'5")	(11'4")	(12'2")	(7'3")	★★ (E-2/E-3)	(35'9")
627B/PP	15S	73-86	T/225	10.7/15.3	35 660	14.91	3.45	3.63	2.21	29.5-29,	11.1
			S/225	(14/20)	(78,620)	(48'11")	(11'4")	(11'11")	(7'2")	28 PR (E-3)	(36'6")
627E/PP	6GB	86-89	T/225	10.7/15.3	36 130	12.89	3.47	3.71	2.21 (7'3")	33.25-29,	10.90
			S/225	(14/20)	(79,655)	(42'3")	(11'4")	(12'2")	2.18 (7'2")	26 PR (E-3)	(35'9")
627E/PP	7CG	90-93	T/330	10.7/15.3	36 620	15.2	3.47	3.71	2.21	33.25-29,	10.9
			S/225	(14/20)	(80,735)	(49'7")	(11'4")	(12'2")	(7'3")	26 PR (E-3)	(35'8")
627F/PP Series II	1DL	93-00	T/330	10.7/15.3	38 103	15.2	3.47	3.71	2.21	33.25-R29	10.9
			S/225	(14/20)	(84,000)	(49'7")	(11'4")	(12'2")	(7'3")	★★ (E-2/E-3)	(35'9")
627G/PP	AXF	00-02	T/330/365	10.7/15.3	38 140	15.2	3.47	3.71	2.20	33.25R29	11.7
			S/225	(14/20)	(84,075)	(49'7")	(11'4")	(12'2")	(7'3")		(38'5")
627G/PP	CEX	02-05	T/330/365	12/17	39 186	15.2	3.47	3.71	2.20	33.25R29	11.7
			S/225/249	(15.7/22)	(86,390)	(49'7")	(11'4")	(12'2")	(7'3")		(38'5")
627G P/P	DBD	05-10	T/330/365	12/17	39 443	15.2	3.58	3.81	2.23	33.25R29	11.7
			S/239/266	(15.7/22)	(86,957)	(49'7")	(11'9")	(12'6")	(7'4")	★★ (E-3)	(38'5")
									Tractor 2.20 (7'3")		
									Scraper		
627H	DBW LCT	10-13	T/407	13/18.4	26 127	14.02	3.57	4.03	2.29	33.25R29	11.8
			S/290	17.1/24	(90,213)	(45'10")	(11'7")	(13'2")	(7'5")	★★ (E-3)	(38'7")
									Tractor 2.28 (7'4")		
									Scraper		
630A & 482C Scraper	52F	60-62	420/335	21/27	35 830	14.63	3.91	4.01	2.39	16.0 × 25-16	11.89
				(27/35)	(79,000)	(48'0")	(12'10")	(13'2")	(7'10")	29.5 × 35-28	(39'0")
									Scraper	33.5 × 33-26	
630A	52F	60-62	420/335	16/21.4	31 430	13.82	3.58	3.73	2.21	16.0 × 25-16	11.89
				(21/28)	(69,300)	(45'4")	(11'9")	(12'3")	(7'3")	29.5 × 35-28	(39'0")
630B	14G	62-63	420/335	16/23	33 520	14.12	3.81	3.71	2.41	16.0-25, 16	13.36
				(21/30)	(73,900)	(46'4")	(12'6")	(12'2")	(7'11")	29.5-35, 28	(43'10")
630B	14G	63-66	400/360	16/23	33 570	14.30	3.81	3.94	2.41	16.0-25, 16	13.36
				(21/30)	(74,000)	(46'11")	(12'6")	(12'11")	(7'11")	29.5-35, 34	(43'10")
630B	10G	62-69	/400	16/23	35 750	14.35	3.81	3.94	2.40	16.0-25, 16	13.36
				(21/30)	(78,800)	(47'1")	(12'6")	(12'11")	(7'10")	29.5-35, 34	(43'10")

T — Tractor Engines  
S — Scraper Engines

## Wheel Tractor-Scrapers (cont'd)

Model	Product Ident. No. Prefix	Years Built	Horse-power Max/ Rated	Capacity Struck/ Heaped m <sup>3</sup> (yd <sup>3</sup> )	Approx. Shipping Weight kg (lb)	Dimensions m (ft)				Tire Size (Standard) & ply rating Tractor & Scraper	Turning Circle m (ft)
						Length	Width	Height	Width of Tread		
631A	51F	60-62	420/335	16/21.4 <b>(21/28)</b>	30 250 <b>(66,700)</b>	12.88 <b>(42'3")</b>	3.58 <b>(11'9")</b>	3.56 <b>(11'8")</b>	2.21 <b>(7'3")</b>	29.5-35, 28	11.00 <b>(36'0")</b>
631B	13G	62-62	420/335	16/23 <b>(21/30)</b>	31 620 <b>(69,700)</b>	13.05 <b>(42'10")</b>	3.81 <b>(12'6")</b>	3.45 <b>(11'5")</b>	2.39 <b>(7'10")</b>	29.5-35, 28	11.31 <b>(37'5")</b>
631B	13G	62-66	420/360	16/23 <b>(21/30)</b>	31 840 <b>(70,200)</b>	13.29 <b>(43'7")</b>	3.81 <b>(12'6")</b>	3.63 <b>(11'11")</b>	2.41 <b>(7'11")</b>	29.5-35, 34	11.31 <b>(37'5")</b>
631C	67M	69-75	/415	16/23 <b>(21/30)</b>	36 350 <b>(80,150)</b>	13.54 <b>(44'5")</b>	3.45 <b>(11'4")</b>	3.91 <b>(12'10")</b>	2.39 <b>(7'10")</b>	29.5-35, 34	11.45 <b>(37'7")</b>
631D	24W	75-85	473/450	16/23.7 <b>(21/31)</b>	42 370 <b>(93,410)</b>	14.25 <b>(46'9")</b>	3.96 <b>(13'0")</b>	4.17 <b>(13'8")</b>	2.46 <b>(8'1")</b>	33.25-35, 38 PR (E-3)	12.2 <b>(40'1")</b>
631E	1AB	85-91	473/450	16.1/23.7 <b>(21/31)</b>	43 365 <b>(95,600)</b>	14.28 <b>(46'10")</b>	3.94 <b>(12'11")</b>	4.29 <b>(14'1")</b>	2.46 <b>(8'1")</b>	37.25-35, 30	12.2 <b>(40'1")</b>
631E Series II	1AB	91-01	473/450	16.1/23.7 <b>(21/31)</b>	44 210 <b>(97,460)</b>	14.56 <b>(47'9")</b>	3.94 <b>(12'11")</b>	4.29 <b>(14'1")</b>	2.46 <b>(8'1")</b>	37.25R35	12.2 <b>(40'1")</b>
631G	AWK	00-02	450/485	16.1/23.7 <b>(21/31)</b>	46 475 <b>(102,460)</b>	14.56 <b>(47'9")</b>	3.94 <b>(12'11")</b>	4.29 <b>(14'1")</b>	2.46 <b>(8'1")</b>	37.25R35	12.2 <b>(40'1")</b>
631G	CLR	03-05	450/485	18.3/26 <b>(24/34)</b>	46 475 <b>(102,460)</b>	14.56 <b>(47'9")</b>	3.94 <b>(12'11")</b>	4.29 <b>(14'1")</b>	2.46 <b>(8'1")</b>	37.25R35	12.2 <b>(40'1")</b>
631G	DFA	05-16	462/500	18.3/26 <b>(24/34)</b>	47 628 <b>(105,002)</b>	14.71 <b>(48'3")</b>	3.94 <b>(12'11")</b>	4.29 <b>(14'1")</b>	2.46 <b>(8'1")</b>	37.25R35	12.2 <b>(40'1")</b>
632	14G	62-63	420/335	21.4/29 <b>(28/38)</b>	37 650 <b>(83,000)</b>	15.21 <b>(49'11")</b>	4.04 <b>(13'3")</b>	4.00 <b>(13'1")</b>	2.44 <b>(8'0")</b>	16.0-25, 16 29.5-35, 34	13.36 <b>(43'10")</b>
632	14G	63-66	420/360	21.4/29 <b>(28/38)</b>	39 420 <b>(86,910)</b>	15.30 <b>(50'2")</b>	4.04 <b>(13'3")</b>	4.00 <b>(13'1")</b>	2.44 <b>(8'0")</b>	16.0-25, 16 29.5-35, 34	13.36 <b>(43'10")</b>
633C	66M	69-75	/415	24.5 <b>(32)</b>	41 750 <b>(92,050)</b>	13.36 <b>(43'10")</b>	3.45 <b>(11'4")</b>	3.96 <b>(13'0")</b>	2.39 <b>(7'10")</b>	33.2-35, 32	11.78 <b>(38'8")</b>
633D	25W	75-85	450	17.7/23 <b>(23/34)</b>	47 570 <b>(104,870)</b>	14.40 <b>(47'3")</b>	3.96 <b>(13'0")</b>	4.24 <b>(13'11")</b>	2.46 <b>(8'1")</b>	33.25-35, 38 PR (E-3)	12.4 <b>(40'7")</b>
633E	1AB	92-96	475	17.7/23 <b>(23/34)</b>	50 800 <b>(112,000)</b>	14.40 <b>(47'3")</b>	3.96 <b>(13'0")</b>	4.24 <b>(13'11")</b>	2.46 <b>(8'1")</b>	37.25R35	13.15 <b>(43'2")</b>
633E Series II	2PS	96-00	490	17.7/23 <b>(23/34)</b>	51 100 <b>(112,670)</b>	14.8 <b>(48'7")</b>	3.96 <b>(13'0")</b>	4.24 <b>(13'11")</b>	2.46 <b>(8'1")</b>	37.25R35	13.15 <b>(43'2")</b>

## Wheel Tractor-Scrapers (cont'd)

Model	Product Ident. No. Prefix	Years Built	Horse-power Max/ Rated	Capacity Struck/ Heaped m <sup>3</sup> (yd <sup>3</sup> )	Approx. Shipping Weight kg (lb)	Dimensions m (ft)				Tire Size (Standard) & ply rating Tractor & Scraper	Turning Circle m (ft)
						Length	Width	Height	Width of Tread		
637	65M	70-75	T/415	16/23	41 300	13.65	3.45	3.93	2.39	33.25-35, 32	11.68
			S/225	(21/30)	(91,050)	(44'9.5")	(11'4")	(12'11")	(7'10")		(38'4")
637/PP	79P	70-75	T/415	16/23	43 700	15.82	3.45	3.93	2.39	33.25-35, 32	11.68
			S/225	(21/30)	(96,350)	(51'11")	(11'4")	(12'11")	(7'10")		(38'4")
637D	26W	75-85	T/450	16/23	46 987	14.8	3.96	4.17	2.46	33.25-35,	12.2
			S/250	(21/31)	(103,590)	(48'8")	(13'0")	(13'8")	(8'1")	38 PR (E-3)	(40'1")
637D/PP	27W	75-85	T/450	16/23	48 531	14.8	3.96	4.17	2.46	33.25-35,	12.2
			S/250	(21/31)	(106,990)	(48'8")	(13'0")	(13'8")	(8'1")	38 PR (E-3)	(40'1")
637E	1FB	85-91	T/450	16/23	49 940	14.28	3.94	4.29	2.46	37.25-35, 30	12.2
			S/250	(21/31)	(110,100)	(46'10")	(12'11")	(14'1")	(8'1")		(40'1")
637E Series II	1FB	91-01	T/450	16/23	50 990	14.56	3.94	4.29	2.46	37.25R35	12.2
			S/250	(21/31)	(112,320)	(47'9")	(12'11")	(14'1")	(8'1")		(40'1")
637E/PP	1FB	85-91	T/450	16/23	51 485	15.88	3.94	4.29	2.46	37.25-35, 30	12.2
			S/250	(21/31)	(113,500)	(52'1")	(12'11")	(14'1")	(8'1")		(40'1")
637E Series II/PP	1FB	91-01	T/450	16/23	52 385	16.49	3.94	4.29	2.46	37.25R35	12.2
			S/250	(21/31)	(115,490)	(54'1")	(12'11")	(14'1")	(8'1")		(40'1")
637G/PP	AXT	00-02	T/450/485	16.1/23.7	53 590	16.49	3.94	4.29	2.46	37.25R35	12.2
			S/249	(21/31)	(118,150)	(54'1")	(12'11")	(14'1")	(8'1")		(40'1")
637G/PP	CEH	02-05	T/450/485	18.3/26	53 562	16.49	3.94	4.29	2.46	37.25R35	12.2
			S/249/274	(24/34)	(118,084)	(54'1")	(12'11")	(14'1")	(8'1")		(40'1")
637G/PP	DFJ	06-16	T/462/500	18.3/26	54 005	16.64	3.94	4.29	2.46	37.25R35	12.2
			S/266/283	(24/34)	(119,060)	(54'7")	(12'11")	(14'1")	(8'1")		(40'1")
639D	99X	79-84	T/450	26	55 030	14.53	3.96	4.06	2.46	37.25-35, 42	12.4
			S/250	(34)	(121,318)	(47'8")	(13'0")	(13'4")	(8'1")	37.25-35, 42	(40'7")
641	64F	62-65	560/450	21.4/29	43 200	14.73	4.04	4.00	2.44	33.5-39, 38	12.68
				(28/38)	(95,300)	(48'4")	(13'3")	(13'1")	(8'0")		(41'7")
641B	65K	69-81	/550	21.4/29	53 070	14.96	4.04	4.24	2.55	37.5-39, 36	13.00
				(28/38)	(117,000)	(49'1")	(13'3")	(13'11")	(8'4")		(42'9")
650	63F	62-64	560/450	24.5/33.6	45 130	16.31	4.24	4.01	2.54	18.0-25, 20	13.87
				(32/44)	(99,500)	(53'6")	(13'11")	(13'2")	(8'4")S	33.5-39, 32	(45'6")
										37.5-39, 36	
650B	22G	62-72	/550	24.5/33.6	46 100	17.00	3.80	4.30	2.65	18.0-25, 20	14.00
				(32/44)	(101,700)	(55'10")	(12'6")	(14'1")	(8'9")S	37.5-39, 28	(46'0")
										37.5-30, 36	

T — Tractor Engines  
S — Scraper Engines

## Wheel Tractor-Scrapers (cont'd)

Model	Product Ident. No. Prefix	Years Built	Horsepower Max/ Rated	Capacity Struck/ Heaped m <sup>3</sup> (yd <sup>3</sup> )	Approx. Shipping Weight kg (lb)	Dimensions m (ft)				Tire Size (Standard) & ply rating Tractor & Scraper	Turning Circle m (ft)
						Length	Width	Height	Width of Tread		
651	33G	62-68	560/450	24.5/33.6 (32/44)	43 730 (96,400)	14.93 (49'0")	4.24 (13'11")	4.01 (13'2")	2.54 (8'4")	37.5-39, 36	13.29 (43'7")
651B	67K	69-84	/550	24.5/33.6 (32/44)	56 340 (124,200)	15.34 (51'4")	4.32 (14'2")	4.29 (14'1")	2.72 (8'11")S	37.5-39, 36	13.5 (44'2")
651E	89Z	82-96	550	24.5/33.6 (32/44)	59 420 (131,000)	16.13 (52'11")	4.37 (14'4")	4.7 (15'5")	2.64 (8'8")	37.5R39	14.5 (47'7")
651E	4YR	96-06	550/605	24.5/33.6 (32/44)	61 126 (134,760)	16.18 (53'1")	4.37 (14'4")	4.7 (15'5")	2.64 (8'8")	40.5/75R39	15.1 (49'8")
657	31G	62-68	T/450 S/335	24.5/33.6 (32/44)	56 550 (124,700)	15.39 (50'6")	4.24 (13'11")	4.09 (13'5")	2.62 (8'7")	37.5-39, 44	13.29 (43'7")
657	46M	68-69	T/500 S/400	24.5/33.6 (32/44)	56 820 (125,155)	15.39 (50'6")	4.24 (13'11")	4.09 (13'5")	2.67 (8'8")	37.5-39, 44	14.57 (47'10")
657B	68K	69-84	T/550 S/400	24.5/33.6 (32/44)	63 100 (139,100)	15.7 (51'8")	4.32 (14'2")	4.21 (13'10")	2.67 (8'9")S	37.5-39, 44	13.7 (45'1")
657E	90Z	82-95	T/550 S/400	24.5/33.6 (32/44)	68 720 (151,500)	17 (55'10")	4.37 (14'4")	4.7 (15'5")	2.64 (8'8")	37.5R39	14.5 (47'7")
657E	6TR	96-06	T/550/605 S/400/440	24.5/33.6 (32/44)	69 078 (152,290)	16.2 (53'1")	4.37 (14'4")	4.7 (15'5")	2.64 (8'8")	40.5/75R39	15.1 (49'8")
657E/PP	91Z	82-95	T/550 S/400	24.5/33.6 (32/44)	72 120 (159,000)	18.01 (59'1")	4.37 (14'4")	4.7 (15'5")	2.64 (8'8")	37.5R39	14.5 (47'7")
657E/PP	5YR	96-06	T/550/605 S/400/440	24.5/33.6 (32/44)	72 857 (160,623)	18.01 (59'1")	4.37 (14'4")	4.7 (15'5")	2.64 (8'8")	40.5/75R39	15.1 (49'8")
660	90F	62-64	560/450	30.6/41.3 (40/54)	49 130 (108,300)	17.04 (55'11")	4.24 (13'11")	4.37 (14'4")	2.59 (8'6")	18.0 × 25-20 37.5 × 39-28 37.5 × 51-36	13.87 (45'6")
660B	58K	70-78	/550	30.6/41.3 (40/54)	59 875 (132,000)	17.27 (56'8")	3.81 (14'2")	4.37 (14'4")	Scrapers	18.0 × 25-20 37.5 × 39-28	14.00 (46'0")
666	77F	63-69	T/450 S/335	30.6/41.3 (40/54)	56 700 (125,000)	17.04 (55'11")	4.24 (13'11")	4.37 (14'4")	2.59 (8'6")	18.0 × 25-20 37.5 × 39-28	13.87 (45'6")
666	64H	67-69	T/500 S/400	30.6/41.3 (40/54)	58 800 (129,645)	17.27 (56'8")	4.24 (13'11")	4.37 (14'4")	2.59 (8'6")	18.0 × 25-20 37.5 × 39-28	13.87 (45'6")
666B	66K	69-78	T/550 S/400	30.6/41.3 (40/54)	67 630 (149,500)	17.27 (56'8")	4.31 (14'4")	4.37 (14'4")	2.59 (8'9")	18.0 × 25-20 37.5 × 51-51	14.00 (46'0")

T — Tractor Engines  
S — Scraper Engines



## TRACTOR-TOWED SCRAPERS

Model	Product Ident. No. Prefix	Years Built	Capacity Struck/Heaped m <sup>3</sup> (yd <sup>3</sup> )	Weight kg (lb)	Width m (ft)	Length m (ft)	Height m (ft)	Width of Cut m (ft)
40	1W	49-59	2.8/3.4 <b>(3.6/4.5)</b>	3348 <b>(7380)</b>	2.27 <b>(7'6")</b>	6.40 <b>(21'0")</b>	1.68 <b>(5'6")</b>	1.82 <b>(6'0")</b>
60	1D	47-53	4.6/6.1 <b>(6.0/8.0)</b>	5579 <b>(12,300)</b>	2.65 <b>(8'9")</b>	8.43 <b>(27'8")</b>	2.36 <b>(7'9")</b>	2.13 <b>(7'0")</b>
60	2W	52-72	5.4/7.0 <b>(7.0/9.0)</b>	6100 <b>(13,500)</b>	2.85 <b>(9'5")</b>	8.52 <b>(28'3")</b>	2.36 <b>(7'9")</b>	2.40 <b>(7'11")</b>
70	8C	46-53	6.7/8.4 <b>(8.7/11.0)</b>	8527 <b>(18,800)</b>	3.02 <b>(10'0")</b>	9.50 <b>(31'2")</b>	2.56 <b>(8'5")</b>	2.43 <b>(8'0")</b>
70	3W	51-57	7.8/9.9 <b>(10.2/13.0)</b>	9140 <b>(20,150)</b>	3.16 <b>(10'5")</b>	9.53 <b>(31'4")</b>	2.61 <b>(8'7")</b>	2.59 <b>(8'6")</b>
80	2D	46-52	10.3/13.8 <b>(13.5/18.0)</b>	11 793 <b>(26,000)</b>	3.38 <b>(11'2")</b>	10.82 <b>(35'6")</b>	2.92 <b>(9'7")</b>	2.74 <b>(9'0")</b>
80	5W	50-56	11.5/15.3 <b>(15.0/20.0)</b>	13 533 <b>(29,836)</b>	3.50 <b>(11'6")</b>	10.92 <b>(35'0")</b>	3.09 <b>(10'2")</b>	2.89 <b>(9'6")</b>
90	9V	51-55	16.2/20.6 <b>(21.2/27.0)</b>	17 208 <b>(37,937)</b>	3.65 <b>(12'0")</b>	12.19 <b>(40'0")</b>	3.20 <b>(10'6")</b>	3.04 <b>(10'0")</b>
435C	45D	56-61	9.9/13.8 <b>(13.0/18.0)</b>	10 659 <b>(23,500)</b>	3.28 <b>(10'10")</b>	10.16 <b>(33'4")</b>	3.01 <b>(9'11")</b>	2.84 <b>(9'4")</b>
435D	45D	59-61	11.5/14.5 <b>(15.0/19.0)</b>	11 521 <b>(25,400)</b>	3.29 <b>(10'10")</b>	10.16 <b>(33'4")</b>	3.01 <b>(9'11")</b>	2.84 <b>(9'4")</b>
435E	85F	61-72	9.2/13.0 <b>(12.0/17.0)</b>	10 400 <b>(22,900)</b>	3.29 <b>(10'10")</b>	10.06 <b>(33'1")</b>	3.07 <b>(10'1")</b>	2.84 <b>(9'4")</b>
435F	45D	62-72	10.7/13.8 <b>(14.0/18.0)</b>	11 300 <b>(24,900)</b>	3.29 <b>(10'10")</b>	10.06 <b>(33'1")</b>	3.02 <b>(9'11")</b>	2.84 <b>(9'4")</b>
435G	27G	63-73	9.2/13.0 <b>(12.0/17.0)</b>	10 400 <b>(22,900)</b>	3.27 <b>(10'9")</b>	10.08 <b>(33'1")</b>	2.97 <b>(9'9")</b>	2.84 <b>(9'4")</b>
463	62C	55-60	13.8/29.1 <b>(18.0/25.0)</b>	14 061 <b>(31,000)</b>	3.58 <b>(11'9")</b>	11.58 <b>(38'0")</b>	3.39 <b>(11'2")</b>	3.15 <b>(10'4")</b>
463C	62C	59-60	16.8/21.4 <b>(22.0/28.0)</b>	15 785 <b>(34,800)</b>	3.58 <b>(11'9")</b>	11.58 <b>(38'0")</b>	3.39 <b>(11'2")</b>	3.15 <b>(10'4")</b>
463E	86F	60-71	13.8/20.0 <b>(18.0/26.0)</b>	15 600 <b>(34,400)</b>	3.58 <b>(11'9")</b>	11.65 <b>(38'3")</b>	3.28 <b>(10'10")</b>	3.15 <b>(10'4")</b>
463F	62C	63-71	16.0/21.4 <b>(21.0/28.0)</b>	15 700 <b>(34,600)</b>	3.58 <b>(11'9")</b>	11.65 <b>(38'3")</b>	3.28 <b>(10'10")</b>	3.15 <b>(10'4")</b>
463G	28G	63-71	13.8/20.0 <b>(18.0/26.0)</b>	13 200 <b>(29,200)</b>	3.58 <b>(11'9")</b>	11.52 <b>(37'10")</b>	3.14 <b>(10'4")</b>	3.15 <b>(10'4")</b>
491	98C	56-64	20.6/26.0 <b>(27.0/34.0)</b>	16 964 <b>(37,400)</b>	3.65 <b>(12'0")</b>	12.13 <b>(39'10")</b>	3.96 <b>(13'0")</b>	3.16 <b>(10'5")</b>
491B	9A	61-63	20.6/26.8 <b>(27.0/35.0)</b>	20 902 <b>(46,060)</b>	3.91 <b>(12'10")</b>	12.49 <b>(41'0")</b>	3.96 <b>(13'0")</b>	3.30 <b>(10'10")</b>
491C	47E	63-70	20.6/26.8 <b>(27.0/35.0)</b>	21 600 <b>(47,500)</b>	3.91 <b>(12'10")</b>	12.64 <b>(41'6")</b>	3.96 <b>(13'0")</b>	3.30 <b>(10'10")</b>
TS180 Lead	E1J	09-13	11/14.5 <b>(14.4/19)</b>	11 748 <b>(25,900)</b>	3.378 <b>(11.08)</b>	8.915 <b>(29.25)</b>	2.362 <b>(7.75)</b>	3.2 <b>(10.5)</b>
TS180 Trail	E1K	09-13	11/14.5 <b>(14.4/19)</b>	12 748 <b>(25,900)</b>	3.378 <b>(11.08)</b>	8.915 <b>(29.25)</b>	2.362 <b>(7.75)</b>	3.2 <b>(10.5)</b>
TS185 Lead	E1R	09-13	11/14.5 <b>(14.4/19)</b>	11 748 <b>(25,900)</b>	3.988 <b>(13.08)</b>	9.119 <b>(29.92)</b>	2.515 <b>(8.25)</b>	3.785 <b>(12.4)</b>
TS185 Trail	E1S	09-13	11/14.5 <b>(14.4/19)</b>	12 748 <b>(25,900)</b>	3.988 <b>(13.08)</b>	9.119 <b>(29.92)</b>	2.515 <b>(8.25)</b>	3.785 <b>(12.4)</b>
TS220 Lead	E1L	09-13	13/18 <b>(17/23.5)</b>	13 145 <b>(28,980)</b>	3.683 <b>(12.08)</b>	9.677 <b>(31.75)</b>	2.464 <b>(8.08)</b>	3.480 <b>(11.4)</b>
TS220 Trail	E1N	09-13	13/18 <b>(17/23.5)</b>	14 145 <b>(28,980)</b>	3.683 <b>(12.08)</b>	9.677 <b>(31.75)</b>	2.464 <b>(8.08)</b>	3.480 <b>(11.4)</b>
TS225 Lead	E1T	09-13	13/18 <b>(17/23.5)</b>	15 250 <b>(33,620)</b>	3.988 <b>(13.08)</b>	10.287 <b>(33.75)</b>	2.515 <b>(8.25)</b>	3.785 <b>(12.4)</b>
TS225 Trail	E1W	09-13	13/18 <b>(17/23.5)</b>	16 250 <b>(33,620)</b>	3.988 <b>(13.08)</b>	10.287 <b>(33.75)</b>	2.515 <b>(8.25)</b>	3.785 <b>(12.4)</b>





**MINING & OFF-HIGHWAY TRUCKS/TRACTORS**

Model	Product Ident. No. Prefix	Years Built	Flywheel Kilowatts (Horsepower)	Capacity Metric Tons (U.S. Tons)	Approx. Weight kg (lb)	Dimensions m (ft)						Tire Size
						Width	Length	Height	Loading Height	Dumping Height (55°)	Turning Circle	
768B	79S	71-78	309 (415)	—	22 000 (48,500)	3.61 (11'10")	6.55 (21'6")	3.48 (11'5")	—	—	18.0 (59'1")	18.00 × 33—24 PR
768C	02X	78-95	336 (450)	—	24 624 (54,285)	4.70 (15'5")	8.00 (26'3")	3.56 (11'8")	—	—	18.5 (60'8")	18.00R33 E-4
769	99F	62-67	298 (400)	31.8 (35.0)	25 365 (55,870)	3.63 (11'11")	7.64 (25'1")	4.05 (13'4")	3.07 (10'1")	7.18 (26'7")	16.5 (54'5")	18.00 × 25—32 PR
769B	99F	67-78	309 (415)	32.0 (35.0)	28 000 (61,800)	3.64 (11'11.5")	7.85 (25'9")	3.89 (12'9")	3.15 (10'4")	7.24 (23'9")	18.0 (59'1")	18.00 × 25—32 PR E-3
769C	01X	78-95	336 (450)	36.9 (40.6)	30 675 (67,855)	4.70 (15'5")	8.00 (26'3")	3.85 (12'8")	3.24 (10'7")	7.68 (25'2")	18.5 (60'8")	18.00R33 E-4
769D	5TR, 5SS, BBB	95-06	363 (487)	36.4 (40.0)	33 875 (74,682)	5.07 (16'8")	8.24 (27'0")	4.03 (13'3")	3.14 (10'4")	7.71 (25'4")	17 (55'9")	18.00R33
770	BZZ	07-14	355 (476)	36.5 (40.3)	34 642 (76,372)	4.75 (15'8")	8.74 (28'9")	4.14 (13'7")	3.12 (10'3")	8.28 (27'2")	20.2 (66'3")	18.00R33 (E-4)
771C	3BJ	92-95	336 (450)	40.0 (44.0)	34 170 (75,345)	4.74 (15'7")	8.20 (26'11")	4.00 (13'1")	3.30 (10'10")	7.68 (25'2")	18.5 (60'8")	18.00R33 E-4
771D	6JR, 6YS, BCA	96-06	363 (487)	41 (45)	33 784 (74,482)	5.07 (16'8")	8.40 (27'7")	4.02 (13'2")	3.40 (11'1")	7.74 (25'5")	17 (55'9")	18.00R33
772	RLB	07-14	399 (535)	46.2 (51.0)	35 864 (79,066)	4.75 (15'8")	8.74 (28'9")	4.22 (13'10")	3.50 (11'6")	8.36 (27'5")	21.6 (70'10")	21.00R33 (E-4)
772	80S	71-78	447 (600)	—	32 100 (70,800)	4.06 (13'4")	7.11 (23'4")	3.68 (12'1")	—	—	22.1 (72'6")	24.00 × 35—36 PR
772B	64W	78-95	485 (650)	—	32 909 (72,550)	4.86 (15'11")	9.12 (29'11")	4.52 (14'10")	—	—	23.5 (77'0")	24.00R35 E-4
773	63G	70-78	447 (600)	45.4 (50.0)	37 800 (83,360)	4.06 (13'4")	8.71 (28'7")	4.27 (14'0")	3.61 (11'10")	8.36 (27'5")	22.1 (72'6")	21.00 × 35—32 PR E-3
773B	63W	78-95	485 (650)	54.3 (59.8)	38 321 (84,500)	4.86 (15'11")	9.12 (29'11")	4.31 (14'2")	3.77 (12'5")	8.72 (28'7")	23.5 (77'0")	24.00R35 E-4
773D	7CS, 7ER	96-01	485 (650)	52.9 (58.4)	43 600 (96,000)	5.08 (16'8")	9.21 (29'11")	4.42 (14'6")	3.79 (12'5")	8.82 (28'11")	22.0 (72'2")	24.00R35
773E	BDA (U.S.)	01-06	501 (671)	54.4 (60.0)	45 480 (100,180)	5.08 (16'8")	9.21 (29'11")	4.42 (14'6")	3.79 (12'5")	8.82 (28'11")	22.0 (72'2")	24.00R35
773E	ASK (India)	09-16	501 (671)	54.4 (60.0)	45 480 (100,180)	5.08 (16'8")	9.21 (29'11")	4.42 (14'6")	3.79 (12'5")	8.82 (28'11")	22.0 (72'2")	24.00R35
773F	EED, EXD	06-11	524 (703)	54.4 (60.0)	45 069 (99,360)	5.43 (17'10")	10.33 (33'11")	4.44 (14'7")	3.77 (12'5")	9.26 (30'5")	26.1 (85'8")	24.00R35 (E-4)
775B	7XJ	92-95	485 (650)	59.5 (65.5)	42 324 (93,325)	4.91 (16'2")	9.33 (30'7")	4.31 (14'2")	3.86 (12'8")	8.72 (28'8")	23.5 (77'7")	24.00R35 E-4
775D	6KR, 8AS	95-01	517 (693)	63.4 (69.9)	43 200 (95,300)	5.08 (16'8")	9.30 (30'6")	4.42 (14'6")	3.91 (12'10")	8.82 (28'11")	22.0 (72'2")	24.00R35
775E	BEC	01-06	544 (730)	63.5 (70.0)	43 470 (95,810)	5.08 (16'8")	9.21 (29'11")	4.42 (14'6")	3.91 (12'10")	8.82 (28'11")	22.0 (72'2")	24.00R35
775F	DLS, EYG	06-11	552 (740)	63.5 (70.0)	45 620 (100,575)	5.43 (17'10")	10.33 (33'11")	4.44 (14'7")	3.97 (13'0")	9.26 (30'5")	26.1 (85'8")	24.00R35 (E-4)

## Mining &amp; Off-Highway Trucks/Tractors (cont'd)

Model	Product Ident. No. Prefix	Years Built	Flywheel Kilowatts (Horsepower)	Capacity Metric Tons (U.S. Tons)	Approx. Weight kg (lb)	Dimensions m (ft)						Tire Size
						Width	Length	Height	Loading Height	Dumping Height (55°)	Turning Circle	
776	14H	75-84	649 (870)	—	49 686 (109,540)	3.51 (11'6")	8.06 (26'5.5")	3.40 (11'2")	—	—	26.8 (88'0")	27.00 × 49—36 PR E-3
776B	6JC	84-92	649 (870)	—	49 896 (110,000)	3.51 (11'6")	8.06 (26'6")	3.40 (11'2")	—	—	25.8 (84'6")	27.00 × 49—36 PR E-3
776C	2TK	92-96	649 (870)	—	49 896 (110,000)	3.51 (11'6")	8.06 (26'5.5")	4.55 (14'11")	—	—	25.8 (84'6")	27.00R49
777	84A	74-84	649 (870)	77.1 (85.0)	58 886 (129,820)	5.463 (17'11")	9.78 (32'1")	4.90 (16'1")	4.14 (13'7")	9.29 (30'6")	26.8 (88'0")	24.00 × 49—42 PR E-3
777B	4YC	84-92	649 (870)	86.2 (95.0)	60 055 (132,422)	5.463 (17'11")	9.79 (32'1")	4.97 (16'4")	4.17 (13'8")	9.42 (30'11")	25.8 (84'6")	24.00 × 49—48 PR E-3
777C	4XJ	92-96	649 (870)	86.2 (95.0)	61 790 (136,227)	5.463 (17'11")	9.79 (32'1")	4.97 (16'4")	4.17 (13'8")	9.42 (30'11")	25.8 (84'6")	27.00R49
777D (Decatur)	3PR, AGC (U.S.)	96-06	699 (938)	90.9 (100.0)	72 575 (160,000)	6.11 (20'0")	9.78 (32'1")	5.15 (16'10")	4.38 (14'4")	10.06 (33'0")	25.3 (83'0")	27.00R49
777D (Decatur)	FKR (India)	06-16	699 (938)	90.9 (100.0)	72 575 (160,000)	6.11 (20'0")	9.78 (32'1")	5.15 (16'10")	4.38 (14'4")	10.06 (33'0")	25.3 (83'0")	27.00R49
777F	JRP, JXP	06-11	700 (938)	90.9 (100.0)	72 739 (160,360)	6.49 (21'4")	10.54 (34'7")	5.17 (17'0")	4.38 (14'4")	10.33 (33'11")	28.4 (93'2")	27.00R49 (E4)
784B	5RK	93-98	962 (1290)	—	89 280 (196,825)	6.74 (22'2")	9.34 (30'8")	5.47 (17'1")	—	—	33.5 (109'10")	36.00R51 E-3
784C	2PZ	98-09	1005 (1348)	—	88 746 (195,651)	7.00 (23'0")	9.34 (30'8")	5.47 (17'1")	—	—	33.8 (110'11")	36.00R51
785	8GB	85-92	962 (1290)	136.0 (150.0)	96 353 (212,458)	6.64 (21'9")	11.02 (36'2")	5.77 (18'11")	4.98 (16'4")	11.20 (36'9")	30.5 (100'4")	33.00 × 51
785B	6HK	92-98	962 (1290)	136.0 (150.0)	96 353 (212,458)	6.64 (21'9")	11.02 (36'2")	5.77 (18'11")	4.98 (16'4")	11.20 (36'9")	30.2 (99'2")	33.00R51
789	9ZC	86-92	1272 (1705)	177.0 (195.0)	121 922 (268,837)	7.67 (25'2")	12.18 (39'11")	6.15 (20'2")	5.21 (17'1")	11.91 (39'1")	30.2 (99'2")	37.00R57
789B	7EK	92-98	1272 (1705)	177.0 (195.0)	121 922 (268,837)	7.67 (25'2")	12.18 (39'11")	6.15 (20'2")	5.21 (17'1")	11.91 (39'1")	30.2 (99'2")	37.00R57
789C	2BW	98-12	1417 (1900)	180.7 (199.2)	132 845 (292,873)	7.67 (25'2")	12.18 (39'11")	6.15 (20'2")	5.21 (17'1")	11.90 (39'1")	30.2 (99'2")	37.00R57
793	3SJ	90-92	1534 (2057)	218.0 (240.0)	376 482 (830,000)	7.60 (24'11")	12.86 (42'3")	6.43 (21'1")	5.86 (19'3")	13.21 (43'4")	30.2 (99'2")	40.00-57
793B	1HL	92-96	1534 (2057)	218.0 (240.0)	376 482 (830,000)	7.60 (24'11")	12.86 (42'3")	6.43 (21'1")	5.86 (19'3")	13.21 (43'4")	30.2 (99'2")	40.00R57
793C	4AR, 4GZ, ATY	96-04	1615 (2166)	218.0 (240.0)	383 739 (846,000)	7.41 (24'4")	12.87 (42'3")	6.43 (21'1")	5.86 (19'3")	13.21 (43'4")	32.4 (106'4")	40.00R57
797	5YW	98-02	2395 (3211)	326.0 (360.0)	557 820 (1,230,000)	9.14 (30'0")	14.63 (48'0")	7.24 (27'6")	7.05 (26'10")	14.94 (49'0")	32.86 (104'10")	55/80R63
797B	JSM	02-09	2513 (3370)	354.0 (394.0)	623 583 (1,375,000)	9.66 (31'9")	14.4 (47'3")	7.72 (25'4")	7.15 (23'6")	15.34 (50'4")	40.5 (132'10")	59/80/R63

<b>ON-HIGHWAY TRUCKS</b>				
<b>Engine</b>	<b>Horsepower (BHP @ 1700 RPM)</b>	<b>Torque Peak (lbf-ft @ 1000 RPM)</b>	<b>Gov. Speed (RPM)</b>	<b>Clutch Engagement Torque (lbf-ft at 800 RPM)</b>
CT11	330/1250	1250	2100	686
	365/1250	1250	2100	686
	370/1350	1350	2100	770
	390/1450	1450	2100	811
CT15	450/1550	1550	2100	1150
	450/1750	1750	2100	1150
	475/1850	1850	2100	1150
	500/1650	1650	2100	1150
	500/1850	1850	2100	1150
	550/1850	1850	2100	1150



## ARTICULATED TRUCKS

Model	Product Ident. No. Prefix	Years Built	Flywheel Kilowatts (Horsepower)	Capacity Metric Tons (U.S. Tons)	Approx. Weight kg (lb)	Dimensions m (ft)						Tire Size
						Width	Length	Height	Loading Height	Dumping Height (55°)	Turning Circle	
D20D	9MG	92-94	134 (180)	18.0 (20.0)	15 000 (33,070)	2.75 (9'0")	8.43 (27'8")	3.30 (10'10")	2.40 (7'11")	5.00 (16'5")	7.25 (24'0")	23.5R25
D22	*	80-82	175 (235)	20.0 (22.0)	17 700 (39,000)	3.00 (9'10")	7.85 (25'9")	3.09 (10'2")	2.44 (8'0")	5.03 (16'6")	7.87 (25'10")	26.5R25
D25	*	80	175 (235)	22.7 (25.0)	17 300 (38,000)	3.00 (9'10")	7.85 (25'9")	3.09 (10'2")	2.44 (8'0")	5.03 (16'6")	7.87 (25'10")	26.5R25
D25B	*	80-83	190 (255)	22.7 (25.0)	17 900 (39,400)	3.00 (9'10")	7.99 (26'2")	3.25 (10'8")	2.44 (8'0")	5.03 (16'6")	7.87 (25'10")	26.5R25
D25C	9YC	85-89	194 (260)	22.7 (25.0)	19 233 (42,400)	3.00 (9'10")	8.73 (28'8")	3.27 (10'9")	2.56 (8'5")	5.28 (17'4")	16.14 (52'11")	26.5R25
D25D	1HK	89-01	194 (260)	22.7 (25.0)	19 450 (42,880)	3.00 (9'10")	8.79 (28'10")	3.34 (10'11")	2.63 (8'8")	5.19 (17'0")	7.95 (26'1")	26.5R25
D30C	7ZC	85-89	194 (260)	27.2 (30.0)	21 320 (47,000)	3.30 (10'10")	8.86 (29'1")	3.33 (10'11")	2.85 (9'4")	5.46 (17'11")	16.33 (53'7")	29.5R25
D30D	3AJ	89-01	213 (285)	27.2 (30.0)	21 690 (47,320)	3.30 (10'10")	8.89 (29'2")	3.40 (11'2")	2.83 (9'3")	5.46 (17'11")	8.20 (26'11")	29.5R25
D35	*	81-83	190 (255)	31.8 (35.0)	20 000 (44,000)	3.27 (10'9")	8.44 (27'8")	3.25 (10'8")	2.91 (9'7")	5.46 (17'11")	7.87 (25'10")	26.5R25 33.25R29
D35C	2GD	85-89	194 (260)	31.8 (35.0)	23 860 (52,600)	3.50 (11'6")	9.44 (31'0")	3.34 (10'11")	2.93 (9'7")	5.32 (17'5")	16.00 (52'5")	Front 29.5R25 Rear 33.5R29
D35 HP	3FD	85-89	287 (385)	31.8 (35.0)	24 950 (55,000)	3.50 (11'6")	9.80 (32'2")	3.51 (11'6")	2.93 (9'7")	5.32 (17'5")	15.78 (51'9")	Front 29.5R25 Rear 33.5R29
D40D	2JJ	89-94	287 (385)	36.3 (40.0)	28 027 (61,800)	3.48 (11'5")	9.76 (32'0")	3.56 (11'8")	3.20 (10'7")	6.00 (19'8")	7.90 (25'11")	Front 29.5R25 Rear 33.25R29
D44	*	81-86	336 (450)	40.0 (44.0)	28 000 (61,600)	3.66 (12'0")	10.05 (33'0")	3.86 (12'8")	2.90 (9'6")	6.35 (20'10")	9.96 (32'8")	33.25R29
D44B	4LD	86-87	343 (460)	40.0 (44.0)	32 296 (71,200)	3.73 (12'3")	10.05 (33'0")	3.98 (13'1")	2.98 (9'9")	6.40 (21'0")	9.08 (29'9")	33.25R29
D250	*	75-78	175 (235)	25.0 (27.5)	18 500 (40,700)	2.66 (8'9")	8.82 (29'0")	3.04 (10'0")	2.61 (8'7")	6.22 (20'5")	7.67 (25'2")	23.5R25
D250B	5WD	85-91	163 (218)	22.7 (25.0)	17 963 (39,600)	2.50 (8'2.5")	9.60 (31'8.5")	3.18 (10'5")	2.55 (8'4.5")	6.23 (20'5")	7.65 (25'1")	20.5R25
D250D	6NG	92-94	160 (214)	22.8 (25.0)	17 300 (38,150)	2.50 (8'2")	9.60 (31'6")	3.21 (10'7")	2.59 (8'6")	6.22 (20'5")	7.61 (25'0")	20.5R25
D250E	5TN	95-98	194 (260)	22.7 (25.0)	20 135 (44,397)	2.74 (9'0")	9.94 (32'7")	3.35 (11'0")	2.70 (8'10")	6.20 (20'4")	7.44 (24'5")	23.5R25
D250E Series II	4PS	98-00	201 (270)	22.7 (25.0)	21 600 (47,628)	2.88 (9'5")	10.00 (32'10")	3.35 (11'0")	2.75 (9'0")	6.39 (20'11")	7.44 (24'5")	23.5R25
725	AFX	00-05	209 (280)	23.6 (26.0)	22 730 (50,120)	2.88 (9'5")	9.92 (32'7")	3.44 (11'3")	2.75 (9'0")	6.43 (21'1")	7.26 (23'10")	23.5R25
725	B1L	05-13	230 (309)	23.6 (26.0)	22 260 (49,075)	2.88 (9'5")	9.92 (32'6")	3.44 (11'3")	2.75 (9'0")	6.41 (21'0")	7.25 (23'10")	23.5R25
725C	TFB	14-16	239 (320)	23.6 (26)	23 220 (51,191)	3.7 (12'2")	10.45 (34'3")	3.47 (11'4")	2.73 (8'9")	6.31 (20'7")	16.2 (53'0")	23.5R25
725C	LFB	14-16	239 (320)	23.6 (26)	22 950 (50,596)	3.7 (12'2")	10.45 (34'3")	3.47 (11'4")	2.73 (8'9")	6.31 (20'7")	16.2 (53'0")	23.5R25

\*Information not available — DJB models.

## Articulated Trucks (cont'd)

Model	Product Ident. No. Prefix	Years Built	Flywheel Kilowatts (Horse-power)	Capacity Metric Tons (U.S. Tons)	Approx. Weight kg (lb)	Dimensions m (ft)						Tire Size
						Width	Length	Height	Loading Height	Dumping Height (55°)	Turning Circle	
D275	*	78-80	175 (235)	25.0 (27.5)	18 700 (41,000)	2.66 (8'9")	8.82 (29'0")	3.17 (10'7")	2.61 (8'7")	6.22 (20'5")	7.75 (25'3")	23.5R25
D275B	*	80-82	190 (255)	25.0 (27.5)	19 200 (42,400)	2.66 (8'9")	8.96 (29'5")	3.21 (10'7")	2.61 (8'7")	6.22 (20'5")	7.75 (25'5")	23.5R25
D300	*	76-78	190 (255)	30.0 (33.0)	19 500 (42,900)	2.80 (9'2")	8.82 (29'0")	3.04 (10'0")	2.68 (8'10")	6.22 (20'5")	7.67 (25'2")	23.5R25
D300B	4SD	85-91	194 (260)	27.2 (30.0)	19 800 (43,520)	2.50 (8'2.5")	9.60 (31'8.5")	3.18 (10'5")	2.55 (8'4.5")	6.23 (20'5")	7.76 (25'6")	23.5R25
D300D	5MG	92-95	213 (285)	27.2 (30.0)	20 680 (45,600)	2.88 (9'6")	9.87 (32'5")	3.28 (10'9")	2.66 (8'9")	6.42 (21'1")	7.76 (25'5")	23.5R25
D300E	7FN	95-98	212 (285)	27.2 (30.0)	21 940 (48,369)	2.89 (9'6")	9.94 (32'7")	3.35 (11'0")	2.85 (9'4")	6.26 (20'6")	7.60 (24'10")	23.5R25
D300E Series II	5KS	98-00	212 (285)	27.2 (30.0)	22 793 (50,235)	2.91 (9'7")	10.00 (32'10")	3.35 (11'0")	2.89 (9'6")	6.44 (21'2")	7.60 (24'10")	23.5R25
730	AGF	00-05	228 (305)	28.1 (31.5)	23 230 (51,222)	2.88 (9'5")	9.92 (32'7")	3.44 (11'3")	2.89 (9'6")	6.50 (21'4")	7.26 (23'10")	23.5R25
730	B1M	05-13	242 (325)	28.1 (31.0)	22 850 (50,376)	2.88 (9'5")	9.92 (32'6")	3.44 (11'3")	2.90 (9'5")	6.50 (21'3")	7.25 (23'0")	23.5R25
730	B1W	05-13	242 (325)	28.1 (31.0)	25 550 (56,328)	3.24 (10'6")	9.73 (31'9")	3.45 (11'3")	3.05 (10'0")	—	7.25 (23'10")	750/65/R25
Ejector 730C	TFF	14-16	280 (375)	28 (31)	24 100 (53,131)	3.7 (12'2")	10.45 (34'3")	3.48 (11'4")	2.91 (9'6")	6.46 (21'2")	16.2 (53'0")	23.5R25
730C	LFF	14-16	k280 (375)	28 (31)	23 700 (52,250)	3.7 (12'2")	10.45 (34'3")	3.48 (11'4")	2.91 (9'6")	6.46 (21'2")	16.2 (53'0")	23.5R25
730C EJ	TFH	14-16	280 (375)	28 (31)	26 800 (59,084)	3.7 (12'2")	10.38 (34'0")	3.45 (11'3")	3.03 (9'9")	—	15.2 (49'9")	750/65
730C EJ	LFH	14-16	280 (375)	28 (31)	26 400 (58,202)	3.7 (12'2")	10.38 (34'0")	3.45 (11'3")	3.03 (9'9")	—	15.2 (49'9")	750/65
D330	*	78-80	190 (255)	30.0 (33.0)	20 000 (43,000)	2.80 (9'2")	8.82 (28'11")	3.17 (10'5")	2.68 (8'9")	6.22 (20'5")	7.80 (25'7")	23.5R25
D330B	*	80-83	190 (255)	30.0 (33.0)	20 200 (44,400)	2.76 (9'1")	9.08 (29'9")	3.25 (10'8")	2.68 (8'9")	6.33 (20'9")	7.92 (26'0")	23.5R25
D350	*	78-80	190 (255)	31.8 (35.0)	21 000 (46,000)	3.00 (9'10")	8.95 (29'4")	3.21 (10'7")	2.82 (9'3")	6.35 (20'10")	7.95 (26'1")	26.5R25
D350B	*	80-83	190 (255)	31.8 (35.0)	21 400 (47,200)	3.00 (9'10")	9.09 (29'10")	3.25 (10'8")	2.85 (9'4")	6.40 (21'0")	7.95 (26'1")	26.5R25
D350C	8XC	85-89	194 (260)	31.8 (35.0)	23 315 (51,400)	3.00 (9'10")	9.93 (32'7")	3.27 (10'9")	2.91 (9'6")	6.52 (21'5")	16.16 (53'0")	26.5R25
D350D	9RF	89-94	213 (285)	31.8 (35.0)	24 595 (54,221)	3.00 (9'10")	9.95 (32'7")	3.34 (11'0")	2.93 (9'7")	6.52 (21'5")	16.06 (52'8")	26.5R25
D350E	9LR	96-99	253 (340)	31.7 (35.0)	27 871 (61,455)	3.26 (10'8")	10.38 (34'1")	3.51 (11'6")	2.94 (9'8")	6.60 (21'8")	8.21 (26'11")	26.5R25
D350E Series II	2XW	99-01	265 (355)	31.8 (35.0)	30 190 (66,560)	3.26 (10'8")	10.65 (35'1")	3.51 (11'6")	2.92 (9'7")	6.83 (20'5")	8.45 (27'8")	26.5R25

\*Information not available — DJB models.

## Articulated Trucks (cont'd)

Model	Product Ident. No. Prefix	Years Built	Flywheel Kilowatts (Horse-power)	Capacity Metric Tons (U.S. Tons)	Approx. Weight kg (lb)	Dimensions m (ft)						Tire Size
						Width	Length	Height	Loading Height	Dumping Height (55°)	Turning Circle	
735	AWR	02-05	272 (365)	32.7 (36)	29 858 (65,825)	3.31 (10'10")	10.89 (35'9")	3.70 (12'2")	2.97 (9'10")	6.96 (22'10")	8.14 (26'9")	26.5R25
735	B1N	05-10	324 (435)	32.7 (36)	31 391 (69,206)	3.43 (11'3")	10.89 (35'7")	3.70 (12'1")	2.98 (9'8")	6.81 (22'3")	16.27 (53'4")	26.5R25
735B	T4P	11-14	326 (437)	32.7 (36)	32 549 (71,758)	3.43 (11'3")	11.00 (36'1")	3.70 (12'1")	2.98 (9'8")	6.81 (22'3")	16.27 (53'4")	26.5R25
735B	L4D	11-14	326 (437)	32.7 (36)	32 549 (71,758)	3.43 (11'3")	11.00 (36'1")	3.70 (12'1")	2.98 (9'8")	6.81 (22'3")	16.27 (53'4")	26.5R25
D400	IMD	85-89	287 (385)	36.3 (40.0)	25 765 (56,800)	3.00 (9'10")	10.42 (34'2")	3.45 (11'4")	3.00 (9'10")	6.53 (21'5")	16.07 (52'9")	26.5R25
D400D	8TF	89-95	287 (385)	36.3 (40.0)	28 027 (61,800)	3.30 (10'8")	10.62 (34'10")	3.56 (11'8")	2.98 (9'9")	6.60 (21'8")	8.26 (27'2")	29.5R25
D400E	2YR	96-99	302 (405)	36.3 (40.0)	29 263 (64,495)	3.30 (10'10")	10.52 (34'6")	3.58 (11'9")	3.07 (10'1")	6.58 (21'7")	8.26 (27'1")	29.5R25
D400E Series II	8PS	99-01	302 (405)	36.3 (40.0)	31 650 (69,760)	3.43 (11'2")	10.65 (35'1")	3.58 (11'9")	3.10 (10'2")	6.92 (23'0")	8.45 (27'8")	29.5R25
D400E II Ejector	APF	99-01	302 (405)	36.3 (40.0)	32 840 (72,380)	3.50 (11'6")	11.00 (36'1")	3.58 (11'9")	3.07 (10'1")	N/A (27'8")	8.45 (27'8")	29.5R25
740	AXM	01-05	309 (415)	38.1 (42)	32 693 (72,075)	3.43 (11'3")	10.89 (35'9")	3.75 (12'4")	3.18 (10'5")	7.07 (23'2")	8.14 (26'9")	29.5R25
740	B1P	05-10	350 (469)	39.5 (43.5)	33 100 (72,973)	3.52 (11'5")	10.89 (35'7")	3.75 (12'3")	3.24 (10'6")	7.09 (23'4")	16.27 (53'4")	29.5R25
740	AZZ	01-05	309 (415)	38.1 (42)	35 270 (77,770)	3.50 (11'6")	11.59 (38'0")	3.75 (12'4")	3.07 (10'0")	3.07 (10'0")	8.63 (28'4")	29.5R25
Ejector 740	AZZ	01-05	309 (415)	38.1 (42)	35 270 (77,770)	3.50 (11'6")	11.59 (38'0")	3.75 (12'4")	3.07 (10'0")	3.07 (10'0")	8.63 (28'4")	29.5R25
Ejector 740B	T4R	11-14	354 (474)	39.5 (43.5)	34 408 (75,857)	3.52 (11'5")	11.00 (36'1")	3.75 (12'3")	3.24 (10'6")	7.09 (23'4")	16.27 (53'4")	29.5R25
740B	L4E	11-14	352 (472)	39.5 (43.5)	34 408 (75,857)	3.52 (11'5")	11.00 (36'1")	3.75 (12'3")	3.24 (10'6")	7.09 (23'4")	16.27 (53'4")	29.5R25
740B EJ	T4S	11-14	354 (474)	38 (42)	36 984 (81,536)	3.53 (11'6")	11.70 (38'4")	3.75 (12'3")	3.07 (10'0")	— (56'7")	17.28 (56'7")	29.5R25
740B EJ	L4F	11-14	352 (472)	38 (42)	36 984 (81,536)	3.53 (11'6")	11.70 (38'4")	3.75 (12'3")	3.07 (10'0")	— (56'7")	17.28 (56'7")	29.5R25
D550	*	78-86	336 (450)	50.0 (55.0)	37 800 (83,400)	3.66 (12'0")	11.35 (37'3")	3.86 (12'8")	3.30 (10'10")	7.83 (25'8")	9.65 (31'8")	33.25R29
D550B	8SD	86-87	343 (460)	50.0 (55.0)	40 370 (89,000)	3.72 (12'2.5")	11.74 (38'6")	3.97 (13'0")	3.22 (10'6")	8.28 (27'2")	8.73 (28'8")	33.25R29

\*Information not available — DJB models.



## WHEEL DOZERS

Model	Product Ident. No. Prefix	Years Built	Flywheel Kilowatts (Horsepower)	Approx. Oper. Wt. kg (lb)	Length (Dozer on ground)		Wheelbase m (ft)	Ground Clearance mm (in)	Transmission	Maximum Speeds km/h (mph)		
					m (ft)	Tread m (ft)				Fwd.	Rev.	
814B	90P	70-81	127 <b>(170)</b>	18 780 <b>(41,400)</b>	6.49 <b>(21'3")</b>	2.16 <b>(7'1")</b>	3.10 <b>(10'2")</b>	356 <b>(14)</b>	PS 4F-4R	32.7 <b>(20.3)</b>	39.3 <b>(24.4)</b>	*
814B	16Z	81-95	161 <b>(216)</b>	20 927 <b>(46,137)</b>	6.82 <b>(22'5")</b>			459 <b>(18)</b>	PS 4F-4R	29.9 <b>(18.6)</b>	34.1 <b>(21.2)</b>	*
814F	9DM	96-02	164 <b>(220)</b>	22 780 <b>(50,115)</b>		2.20 <b>(7'3")</b>	3.35 <b>(11'0")</b>	448 <b>(18)</b>	PS 4F-4R	29.9 <b>(18.6)</b>	34.1 <b>(21.2)</b>	
814F	BGF	03-06	179 <b>(240)</b>	21 713 <b>(47,877)</b>	6.82 <b>(22'5")</b>	2.20 <b>(7'3")</b>	3.35 <b>(11'0")</b>	448 <b>(18)</b>	PS 4F-4R	29.9 <b>(18.6)</b>	34.1 <b>(21.2)</b>	
814F II	BXG	06	173 <b>(232)</b>	20 755 <b>(45,765)</b>	6.90 <b>(22'6")</b>	2.20 <b>(7'3")</b>	3.60 <b>(11'8")</b>	366 <b>(14)</b>	PS 4F-4R	31 <b>(19.3)</b>	34.9 <b>(21.8)</b>	
824	29G	63-65	224 <b>(300)</b>	31 700 <b>(70,000)</b>	7.04 <b>(23'1")</b>	2.37 <b>(7'10")</b>	3.35 <b>(11'8")</b>	470 <b>(18.2)</b>	PS 3F-3R	34.1 <b>(21.2)</b>	34.1 <b>(21.2)</b>	
824B	36H	65-78	224 <b>(300)</b>	33 330 <b>(73,480)</b>	7.40 <b>(24'3.5")</b>	2.32 <b>(7'7.5")</b>	3.55 <b>(11'8")</b>	490 <b>(19.4)</b>	PS 3F-3R	29.8 <b>(18.5)</b>	29.8 <b>(18.5)</b>	
824C	85X	78-95	235 <b>(315)</b>	30 380 <b>(66,975)</b>	7.69 <b>(25'2")</b>	2.36 <b>(7'7.5")</b>	3.53 <b>(11'7")</b>	477 <b>(18.8)</b>	PS 4F-4R	33.2 <b>(20.6)</b>	37.8 <b>(23.5)</b>	
824G	4SN	96-02	235 <b>(315)</b>	26 620 <b>(58,697)</b>	8.02 <b>(26'4")</b>	2.44 <b>(8'0")</b>	3.70 <b>(12'2")</b>	383 <b>(15)</b>	PS 4F-4R	33 <b>(20.4)</b>	37.8 <b>(23.5)</b>	
824G II	AXB	03-04	253 <b>(339)</b>	28 724 <b>(63,325)</b>	8.02 <b>(26'4")</b>	2.44 <b>(8'0")</b>	3.70 <b>(12'2")</b>	383 <b>(15)</b>	PS 4F-4R	32.1 <b>(20)</b>	36.6 <b>(22.7)</b>	
824H	ASX	05-14	264 <b>(354)</b>	28 724 <b>(63,325)</b>	8.20 <b>(26'9")</b>	2.44 <b>(8'0")</b>	3.70 <b>(12'2")</b>	358 <b>(14)</b>	PS 4F-4R	32.1 <b>(20)</b>	36.6 <b>(22.7)</b>	
834	43E	63-74	298 <b>(400)</b>	40 300 <b>(88,800)</b>	7.75 <b>(25'5")</b>	2.54 <b>(8'4")</b>	3.80 <b>(12'6")</b>	510 <b>(20.0)</b>	PS 3F-3R	32.8 <b>(20.4)</b>	35.7 <b>(22.2)</b>	
834B	7BR	74-00	336 <b>(450)</b>	46 350 <b>(102,200)</b>	8.72 <b>(28'7")</b>			466 <b>(18)</b>	PS 4F-4R	34.1 <b>(21.2)</b>	41.8 <b>(25.9)</b>	
834G	6GZ	98-01	359 <b>(481)</b>	44 680 <b>(98,500)</b>	10.40 <b>(34'2")</b>	2.59 <b>(8'6")</b>	4.55 <b>(14'11")</b>	541 <b>(21)</b>	PS 4F-3R	38.5 <b>(23.9)</b>	23.0 <b>(14.3)</b>	**
834G	BPC	02-04	359 <b>(481)</b>	47 106 <b>(103,849)</b>	10.40 <b>(34'2")</b>	2.59 <b>(8'6")</b>	4.55 <b>(14'11")</b>	541 <b>(21)</b>	PS 4F-3R	38.5 <b>(23.9)</b>	23.0 <b>(14.3)</b>	
834H	BTX	05-13	372 <b>(489)</b>	47 106 <b>(103,849)</b>	10.42 <b>(34'2")</b>	2.59 <b>(8'6")</b>	4.55 <b>(14'11")</b>	531 <b>(21)</b>	PS 4F-3R	35.4 <b>(22)</b>	21.4 <b>(13.3)</b>	
844	2KZ	98-01	466 <b>(625)</b>	69 230 <b>(152,620)</b>	10.90 <b>(35'9")</b>	3.10 <b>(10'0")</b>	4.60 <b>(15'1")</b>	552 <b>(22)</b>	PS 3F-3R	22.5 <b>(14.0)</b>	25.0 <b>(15.5)</b>	***
844	BBN	01-05	466 <b>(625)</b>	70 815 <b>(156,120)</b>	10.90 <b>(35'9")</b>	3.10 <b>(10'0")</b>	4.60 <b>(15'1")</b>	552 <b>(22)</b>	PS 3F-3R	22.5 <b>(14.0)</b>	25.0 <b>(15.5)</b>	
844H	BTW	05-14	468 <b>(627)</b>	70 815 <b>(156,120)</b>	10.94 <b>(35'9")</b>	3.10 <b>(10'0")</b>	4.60 <b>(15'1")</b>	475 <b>(19)</b>	PS 3F-3R	21 <b>(13)</b>	23 <b>(14.3)</b>	
854G	1JW	97-99	597 <b>(800)</b>	99 400 <b>(219,125)</b>	13.40 <b>(44'0")</b>	3.30 <b>(10'10")</b>	5.89 <b>(19'3")</b>	691 <b>(27)</b>	PS 3F-3R	20.5 <b>(12.7)</b>	22.7 <b>(14.1)</b>	****
854G	AMP	00-04	597 <b>(800)</b>	99 400 <b>(219,125)</b>	13.40 <b>(44'0")</b>	3.30 <b>(10'10")</b>	5.39 <b>(19'3")</b>	691 <b>(27)</b>	PS 3F-3R	20.5 <b>(12.7)</b>	22.7 <b>(14.1)</b>	
854G	A4W	04-08	597 <b>(800)</b>	99 400 <b>(219,125)</b>	13.40 <b>(44'0")</b>	3.30 <b>(10'10")</b>	5.39 <b>(19'3")</b>	691 <b>(27)</b>	PS 3F-3R	20.5 <b>(12.7)</b>	22.7 <b>(14.1)</b>	
854K	221	08-11	597 <b>(801)</b>	98 100 <b>(216,273)</b>	13.45 <b>(44'0")</b>	3.30 <b>(10'10")</b>	5.89 <b>(19'3")</b>	691 <b>(27)</b>	PS 3F-3R	21.2 <b>(13.2)</b>	23.5 <b>(14.6)</b>	
854K	H9K H8M	11-16	597 <b>(801)</b>	98 100 <b>(216,273)</b>	13.45 <b>(44'0")</b>	3.30 <b>(10'10")</b>	5.89 <b>(19'3")</b>	691 <b>(27)</b>	PS 3F-3R	21.2 <b>(13.2)</b>	23.5 <b>(14.6)</b>	

\*Turbocharged, Articulated Steering.

\*\*Move to "G" Series.

\*\*\*New model from Tiger (590).

\*\*\*\*New model from Tiger (790).



## COMPACTORS

Model	Product Ident. No. Prefix	Years Built	Flywheel Kilowatts (Horsepower)	Approx. Oper. Wt. kg (lb)	Drum Width m (ft)	Articulated Steering Angle, Maximum	Transmission	Maximum Speeds km/h (mph)		
								Fwd.	Rev.	
815	91P	70-81	127 (170)	17 300 (38,200)	0.97 (3'2")	44° Either Side	Power Shift 4F-4R	30.1 (18.7)	35.7 (22.2)	*
815B	17Z	81-95	161 (216)	20 035 (44,175)	0.98 (3'2")	45° Either Side	Power Shift 4F-4R	37.5 (23.3)	42.9 (26.6)	*
815F	1GN	96-02	164 (220)	20 952 (46,096)	0.98 (3'2")	36° Either Side	Power Shift 4F-4R	37.6 (23.3)	43.0 (26.7)	
815F	BKL	03-06	179 (240)	20 755 (45,765)	0.98 (3'2")	36° Either Side	Power Shift 3F-3R	17.9 (11.1)	19.5 (12.1)	
815F II	BYN	06	173 (232)	20 755 (45,756)	0.99 (3'3")	42° Either side	Power Shift 3F-3R	17.6 (11.0)	19.5 (12.2)	
816	57U	72-81	127 (170)	18 550 (40,900)	1.02 (3'4")	44° Either Side	Power Shift 4F-4R	30.1 (18.6)	35.7 (22.4)	**
816B	15Z	81-95	161 (216)	20 628 (45,477)	1.02 (3'4")	42° Either Side	Power Shift 4F-4R	35.3 (22.0)	40.4 (25.1)	**
816F	5FN	96-02	164 (220)	20 879 (45,934)	1.02 (3'4")	42° Either Side	Power Shift 4F-4R	36.3 (22.5)	41.4 (25.7)	
816F II	BZR	06	173 (232)	23 748 (52,364)	1.016 (3'4")	42° Either side	Power Shift 2F-2R	9.5 (5.9)	10.6 (6.6)	
825B	43N	70-78	224 (300)	30 075 (66,300)	1.13 (3'8")	44° Either Side	Power Shift 4F-4R	29.8 (18.5)	29.8 (18.5)	
825C	86X	78-96	231 (310)	32 400 (71,432)	1.13 (3'8")	42° Either Side	Power Shift 4F-4R	29.8 (18.5)	33.9 (21.1)	
825G	6RN	96-02	235 (315)	31 740 (69,828)	1.13 (3'8")	42° Either Side	Power Shift 3F-3R	15.6 (9.7)	17.2 (10.7)	
825G II	AXB	03-04	253 (339)	32 734 (72,164)	1.13 (3'8")	42° Either Side	Power Shift 3F-3R	15.6 (9.7)	17.2 (10.7)	
825H	AZW	05-14	264 (354)	32 734 (72,164)	1.125 (3'7")	42° Either side	Power Shift 3F-3R	15.6 (9.7)	17.2 (10.7)	
826C	87X	78-95	235 (315)	34 920 (76,990)	1.20 (3'11")	42° Either Side	Power Shift 4F-4R	32.5 (20.2)	37.2 (23.1)	
826G	7LN	96-02	235 (315)	33 350 (73,537)	1.20 (3'11")	42° Either Side	Power Shift 2F-2R	11.2 (6.9)	13.5 (8.4)	
826H	AWF	05-14	264 (354)	36 967 (81,498)	1.20 (3'11")	42° Either side	Power Shift 2F-2R	9.7 (6.03)	10.6 (6.59)	
835	44N	70-74	298 (400)	35 900 (79,100)	1.22 (4'0")	44° Either Side	Power Shift 3F-3R	32.2 (20.0)	34.8 (21.6)	
836	3RL	93-95	336 (450)	45 450 (100,000)	1.40 (4'7")	35° Either Side	Power Shift 2F-2R	11.3 (7.0)	14.0 (8.7)	*
836G	7MZ	98-01	351 (471)	53 680 (118,348)	1.40 (4'7")	35° Either Side	Power Shift 2F-2R	6.0 (3.7)	10.2 (6.3)	
836H	BXD	05-13	372 (499)	53 682 (118,348)	1.40 (4'7")	35° Either side	Power Shift 2F-2R	10.9 (6.8)	11.4 (7.1)	

\*Turbocharged, Articulated Steering.

\*\*Turbocharged, ROPS Cab, Sleeve Metering Fuel System.





## WHEEL LOADERS

Model	Product Ident. No. Prefix	Years Built	Flywheel Horsepower	Approx. Shipping Wt. kg (lb)	Rated Capacity m <sup>3</sup> (yd <sup>3</sup> )	Breakout Force kg (lb)	Width Over Tires m (ft)	Ground Clearance mm (in)	Max. Reach at max. height mm (ft)	Dump Clearance at max. height m (ft)	Maximum Speeds km/h (mph)		Remarks
											Fwd.	Rev.	
903C	MW4	14-16	42	4300 (9500)	0.6 (0.8)	2345 (5171)	1.71 (5'7")	395 (16)	885 (2'11")	2.43 (8'0")	16.0 (10.0)	16.0 (10.0)	
904B	B4L	05-08	52	4368 (9630)	0.6 (0.8)	3633 (8009)	1.70 (5'7")	218 (8.6)	664 (2'2")	2.38 (7'10")	20.0 (12.4)	20.0 (12.4)	
906H		07-12	70	5630 (12,412)	0.9 (1.2)	4283 (9442)	1.84 (6'0")	300 (11.8)	810 (2'8")	2.40 (7'10")	35.0 (22.0)	35.0 (22.0)	
906H2		12-15	71	5630 (12,412)	0.9 (1.2)	4283 (9442)	1.84 (6'0")	300 (11.8)	810 (2'8")	2.40 (7'10")	35.0 (22.0)	35.0 (22.0)	
907H		07-12	70	5810 (12,809)	1.0 (1.3)	4283 (9442)	1.84 (6'0")	300 (11.8)	810 (2'8")	2.40 (7'10")	35.0 (22.0)	35.0 (22.0)	
907H2		12-15	71	5810 (12,809)	1.0 (1.3)	4283 (9442)	1.84 (6'0")	300 (11.8)	810 (2'8")	2.40 (7'10")	35.0 (22.0)	35.0 (22.0)	
908H		07-12	79	6465 (14,253)	1.1 (1.4)	4793 (10,566)	1.99 (6'6")	340 (13.0)	855 (2'10")	2.50 (8'3")	35.0 (22.0)	35.0 (22.0)	
908H2		12-15	71	6465 (14,253)	1.1 (1.4)	4793 (10,566)	1.99 (6'5")	340 (13.0)	855 (2'10")	2.50 (8'3")	35.0 (22.0)	35.0 (22.0)	
910	80V	73-79	65	6100 (13,400)	1.0 (1.25)	4530 (10,000)	2.07 (6'10")	405 (16)	860 (2'10")	2.46 (8'1")	24.1 (15.0)	10.6 (6.6)	
910	40Y	79-89	65	6658 (14,679)	1.0 (1.25)	5838 (12,870)	2.07 (6'10")	405 (16)	930 (3'0.6")	2.40 (7'10")	23.9 (14.8)	10.6 (6.6)	
910	41Y	79-89	65	6658 (14,679)	1.0 (1.25)	5838 (12,870)	2.07 (6'10")	405 (16)	930 (3'0.6")	2.40 (7'10")	23.5 (14.6)	24.9 (15.5)	
910E	1SF	89-92	78	7298 (16,062)	1.3 (1.7)	6503 (14,339)	2.15 (7'0")	343 (13.5)	1000 (3'3.4")	2.57 (8'5")	34.0 (21.1)	22.4 (13.9)	3114 Engine Z Bar Linkage
910F	1SF	92-95	80	7009 (15,452)	1.3 (1.7)	6443 (14,207)	2.15 (7'0")	370 (14.6)	981 (3'3")	2.60 (8'6")	34.0 (21.1)	22.4 (13.9)	3114 Engine Z Bar Linkage
910K	AY4	14-16	74	7470 (16,463)	1.2 (1.6)	6741 (14,857)	2.26 (7'5")	348 (13)	820 (2'8")	2.81 (9'2")	40.0 (25.0)	40.0 (25.0)	
914G	7ZM 9WM PDF	95-14	95	7950 (17,530)	1.2-1.4 (1.6-1.8)	6200 (14,007)	2.258 (7'5")	456 (16.3)	973 (3'2")	2.659 (8'9")	35.0 (22.0)	35.0 (22.0)	C4.4 ACERT Engine Z Bar Linkage Hystat Transmission
914G2	KNP	12-14	95	7950 (17,530)	1.2-1.4 (1.6-1.8)	6200 (14,007)	2.258 (7'5")	456 (16.3)	973 (3'2")	2.659 (8'9")	35.0 (22.0)	35.0 (22.0)	C4.4 ACERT Engine Z Bar Linkage Hystat Transmission
914K	CD2	14-16	74	8467 (18,663)	1.4 (1.8)	7357 (16,214)	2.26 (7'5")	405 (15)	847 (2'9")	2.78 (9'1")	40.0 (25.0)	40.0 (25.0)	
916	2XB	86-92	85	8554 (18,857)	1.4 (1.75)	9124 (20,115)	2.33 (7'8")	322 (12.7)	926 (3'0.5")	2.65 (8'9")	24.8 (15.4)	25.0 (15.5)	3204 Engine Z Bar Linkage
918F	3TJ	92-94	98	8973 (19,785)	1.5 (2.0)	9795 (21,598)	2.33 (91.6")	318 (13)	802 (2'8")	2.78 (9'1")	37.0 (23.0)	24.5 (15.2)	3114 Engine Z Bar Linkage
920	62K	69-84	80	8440 (18,600)	1.2 (1.5)	7901 (17,419)	2.16 (7'1")	335 (13)	740 (2'5")	2.77 (9'1")	43.8 (27.2)	23.2 (14.4)	
922A	59A	60-62	80	7350 (16,200)	0.93 (1.25)	6850 (15,100)	2.12 (7'0")	368 (15)	655 (2'2")	2.60 (8'7")	30.4 (18.9)	32.8 (20.4)	
922B	88J	62-68	80	7670 (16,900)	1.15 (1.5)	9000 (19,900)	2.25 (7'5")	390 (16)	680 (2'3")	2.60 (8'7")	33.6 (20.9)	42.9 (26.7)	

## Wheel Loaders (cont'd)

Model	Product Ident. No. Prefix	Years Built	Flywheel Horse-power	Approx. Shipping Wt. kg (lb)	Rated Capacity m <sup>3</sup> (yd <sup>3</sup> )	Breakout Force kg (lb)	Width Over Tires m (ft)	Ground Clearance mm (in)	Max. Reach at max. height mm (ft)	Dump Clearance at max. height m (ft)	Maximum Speeds km/h (mph)		Remarks
											Fwd.	Rev.	
924F	5NN	94-99	105	9025 <b>(19,900)</b>	1.7 <b>(2.25)</b>	9553 <b>(21,067)</b>	2.33 <b>(7'6")</b>	318 <b>(12.5)</b>	855 <b>(2'8")</b>	2.70 <b>(8'10")</b>	38.2 <b>(23.6)</b>	23.6 <b>(14.8)</b>	
924G	9SW	99-02	120	9615 <b>(21,197)</b>	1.8 <b>(2.3)</b>	9876 <b>(21,772)</b>	2.36 <b>(7'9")</b>	370 <b>(15)</b>	1318 <b>(4'4")</b>	2.828 <b>(9'4")</b>	38.5 <b>(23.9)</b>	21.8 <b>(13.5)</b>	
924G	3PZ	99-02	120	9615 <b>(21,197)</b>	1.8 <b>(2.3)</b>	9876 <b>(21,772)</b>	2.36 <b>(7'9")</b>	370 <b>(15)</b>	1318 <b>(4'4")</b>	2.828 <b>(9'4")</b>	38.5 <b>(23.9)</b>	21.8 <b>(13.5)</b>	
924G	AAN	99-02	120	9615 <b>(21,197)</b>	1.8 <b>(2.3)</b>	9876 <b>(21,772)</b>	2.36 <b>(7'9")</b>	370 <b>(15)</b>	1318 <b>(4'4")</b>	2.828 <b>(9'4")</b>	38.5 <b>(23.9)</b>	21.8 <b>(13.5)</b>	
924G	DDA	02-07	129	9977 <b>(21,996)</b>	1.8 <b>(2.3)</b>	11 452 <b>(25,247)</b>	2.36 <b>(7'9")</b>	370 <b>(15)</b>	1451 <b>(4'10")</b>	2.918 <b>(9'7")</b>	38.5 <b>(23.9)</b>	21.8 <b>(13.5)</b>	
924G	RBB	02-07	129	9977 <b>(21,996)</b>	1.8 <b>(2.3)</b>	11 452 <b>(25,247)</b>	2.36 <b>(7'9")</b>	370 <b>(15)</b>	1451 <b>(4'10")</b>	2.918 <b>(9'7")</b>	38.5 <b>(23.9)</b>	21.8 <b>(13.5)</b>	
924G	WMB	02-07	129	9977 <b>(21,996)</b>	1.8 <b>(2.3)</b>	11 452 <b>(25,247)</b>	2.36 <b>(7'9")</b>	370 <b>(15)</b>	1451 <b>(4'10")</b>	2.918 <b>(9'7")</b>	38.5 <b>(23.9)</b>	21.8 <b>(13.5)</b>	
924Gz	6YW	99-02	120	9615 <b>(21,197)</b>	1.8 <b>(2.3)</b>	9876 <b>(21,772)</b>	2.36 <b>(7'9")</b>	370 <b>(15)</b>	1318 <b>(4'4")</b>	2.828 <b>(9'4")</b>	38.5 <b>(23.9)</b>	21.8 <b>(13.5)</b>	
924Gz	3DZ	99-03	120	9615 <b>(21,197)</b>	1.8 <b>(2.3)</b>	9876 <b>(21,772)</b>	2.36 <b>(7'9")</b>	370 <b>(15)</b>	1318 <b>(4'4")</b>	2.828 <b>(9'4")</b>	38.5 <b>(23.9)</b>	21.8 <b>(13.5)</b>	
924Gz	AAB	99-04	120	9615 <b>(21,197)</b>	1.8 <b>(2.3)</b>	9876 <b>(21,772)</b>	2.36 <b>(7'9")</b>	370 <b>(15)</b>	1318 <b>(4'4")</b>	2.828 <b>(9'4")</b>	38.5 <b>(23.9)</b>	21.8 <b>(13.5)</b>	
924Gz	DFZ	02-04	129	9615 <b>(21,197)</b>	1.8 <b>(2.3)</b>	9876 <b>(21,772)</b>	2.36 <b>(7'9")</b>	370 <b>(15)</b>	1318 <b>(4'4")</b>	2.828 <b>(9'4")</b>	38.5 <b>(23.9)</b>	21.8 <b>(13.5)</b>	
924Gz	RTA	02-07	129	9615 <b>(21,197)</b>	1.8 <b>(2.3)</b>	9876 <b>(21,772)</b>	2.36 <b>(7'9")</b>	370 <b>(15)</b>	1318 <b>(4'4")</b>	2.828 <b>(9'4")</b>	38.5 <b>(23.9)</b>	21.8 <b>(13.5)</b>	
924Gz	WGX	02-07	129	9615 <b>(21,197)</b>	1.8 <b>(2.3)</b>	9876 <b>(21,772)</b>	2.36 <b>(7'9")</b>	370 <b>(15)</b>	1318 <b>(4'4")</b>	2.828 <b>(9'4")</b>	38.5 <b>(23.9)</b>	21.8 <b>(13.5)</b>	
924H	HXC	07-13	132	11 635 <b>(25,651)</b>	2.1 <b>(2.7)</b>	9003 <b>(19,848)</b>	2.49 <b>(8'2")</b>	436 <b>(17)</b>	1060 <b>(3'6")</b>	2.759 <b>(9'1")</b>	39.7 <b>(24.7)</b>	22.9 <b>(14.2)</b>	
924Hz	JZZ	10-13	132	11 021 <b>(24,297)</b>	2.1 <b>(2.7)</b>	8975 <b>(19,787)</b>	2.49 <b>(8'2")</b>	436 <b>(17)</b>	859 <b>(2'10")</b>	2.757 <b>(9'1")</b>	39.7 <b>(24.7)</b>	22.9 <b>(14.2)</b>	
924K	PWR	11-15	146	12 868 <b>(28,360)</b>	1.9 <b>(2.5)</b>	10 223 <b>(22,531)</b>	2.54 <b>(8'4")</b>	400 <b>(15.7)</b>	1024 <b>(3'4")</b>	2885 <b>(9'5")</b>	40.0 <b>(25.0)</b>	40.0 <b>(25.0)</b>	
924K	HJF ENC	13-15	141	11 550 <b>(25,464)</b>	1.7 <b>(2.2)</b>	12 273 <b>(27,057)</b>	2.54 <b>(8'4")</b>	397 <b>(15.7)</b>	950 <b>(3'1")</b>	2857 <b>(9'4")</b>	40.0 <b>(25.0)</b>	40.0 <b>(25.0)</b>	
926	94Z	84-87	105	8800 <b>(19,400)</b>	1.21 <b>(1.75)</b>	5070 <b>(11,179)</b>	2.33 <b>(7'8")</b>	341 <b>(13.5)</b>	924 <b>(3'0")</b>	2.67 <b>(8'9")</b>	30.3 <b>(18.8)</b>	32.3 <b>(20.0)</b>	
926E	94Z	87-92	110	9432 <b>(20,794)</b>	1.7 <b>(2.25)</b>	10 044 <b>(22,143)</b>	2.33 <b>(7'8")</b>	341 <b>(13.5)</b>	1003 <b>(3'3.5")</b>	2.75 <b>(9'0")</b>	34.2 <b>(21.2)</b>	36.8 <b>(22.9)</b>	3204 Engine Z Bar Linkage
928F	2XL	93-96	120	10 870 <b>(23,920)</b>	2.1 <b>(2.75)</b>	10 090 <b>(22,200)</b>	2.43 <b>(8'0")</b>	318 <b>(13)</b>	956 <b>(3'2")</b>	2.74 <b>(9'0")</b>	36.5 <b>(22.6)</b>	21.1 <b>(13.1)</b>	3116 Engine Z Bar Linkage
928G	6XR	96-02	125	11 250 <b>(24,802)</b>	2.0 <b>(2.6)</b>	11 723 <b>(25,849)</b>	2.44 <b>(8'0")</b>	408 <b>(16)</b>	1455 <b>(4'9")</b>	2.879 <b>(9'5")</b>	37.7 <b>(23.4)</b>	25.8 <b>(16)</b>	
928G	7SR	96-02	125	11 250 <b>(24,802)</b>	2.0 <b>(2.6)</b>	11 723 <b>(25,849)</b>	2.44 <b>(8'0")</b>	408 <b>(16)</b>	1455 <b>(4'9")</b>	2.879 <b>(9'5")</b>	37.7 <b>(23.4)</b>	25.8 <b>(16)</b>	
928Gz	DJD	02-07	143	11 250 <b>(24,802)</b>	2.0 <b>(2.6)</b>	11 723 <b>(25,849)</b>	2.44 <b>(8'0")</b>	408 <b>(16)</b>	1455 <b>(4'9")</b>	2.879 <b>(9'5")</b>	37.7 <b>(23.4)</b>	25.8 <b>(16)</b>	
928Gz	WLG	02-07	143	11 250 <b>(24,802)</b>	2.0 <b>(2.6)</b>	11 723 <b>(25,849)</b>	2.44 <b>(8'0")</b>	408 <b>(16)</b>	1455 <b>(4'9")</b>	2.879 <b>(9'5")</b>	37.7 <b>(23.4)</b>	25.8 <b>(16)</b>	
928Hz	CXK	07-13	152	12 618 <b>(27,818)</b>	2.3 <b>(3.0)</b>	9002 <b>(19,846)</b>	2.57 <b>(8'5")</b>	408 <b>(16)</b>	963 <b>(3'2")</b>	2.842 <b>(9'4")</b>	37.6 <b>(23.4)</b>	26.7 <b>(16.6)</b>	

Wheel Loaders (cont'd)

Model	Product Ident. No. Prefix	Years Built	Flywheel Horse-power	Approx. Shipping Wt. kg (lb)	Rated Capacity m <sup>3</sup> (yd <sup>3</sup> )	Breakout Force kg (lb)	Width Over Tires m (ft)	Ground Clearance mm (in)	Max. Reach at max. height mm (ft)	Dump Clearance at max. height m (ft)	Maximum Speeds km/h (mph)		Remarks
											Fwd.	Rev.	
930	41K	68-85	100	9660 <b>(21,300)</b>	1.7 <b>(2.25)</b>	7900 <b>(17,410)</b>	2.39 <b>(7'10")</b>	348 <b>(13.7)</b>	1350 <b>(3'9")</b>	2.79 <b>(9'2")</b>	44.2 <b>(27.5)</b>	23.3 <b>(14.5)</b>	Z Bar Linkage
930G	TWR	05-07	149	12 756 <b>(28,122)</b>	2.3 <b>(3.0)</b>	14 567 <b>(32,115)</b>	2.41 <b>(7'11")</b>	421 <b>(16)</b>	1542 <b>(5'1")</b>	2.917 <b>(9'7")</b>	38.3 <b>(23.8)</b>	24.1 <b>(15)</b>	
930G	TFR	05-07	149	12 756 <b>(28,122)</b>	2.3 <b>(3.0)</b>	14 567 <b>(32,115)</b>	2.41 <b>(7'11")</b>	421 <b>(16)</b>	1542 <b>(5'1")</b>	2.917 <b>(9'7")</b>	38.3 <b>(23.8)</b>	24.1 <b>(15)</b>	
930H	DHC	07-13	152	13 174 <b>(29,044)</b>	2.3 <b>(3.0)</b>	12 852 <b>(28,334)</b>	2.57 <b>(8'5")</b>	411 <b>(16)</b>	995 <b>(3'3")</b>	2.773 <b>(9'1")</b>	39.7 <b>(24.7)</b>	22.9 <b>(14.2)</b>	
930K	RHN	11-15	160	13 829 <b>(30,479)</b>	2.1 <b>(2.7)</b>	12 366 <b>(27,254)</b>	2.54 <b>(8'4")</b>	400 <b>(15.7)</b>	1064 <b>(3'5")</b>	2828 <b>(9'3")</b>	40.0 <b>(25.0)</b>	40.0 <b>(25.0)</b>	
930K	EYE DYB	13-15	160	13 135 <b>(28,958)</b>	2.1 <b>(2.7)</b>	12 366 <b>(27,254)</b>	2.54 <b>(8'4")</b>	397 <b>(15.7)</b>	1033 <b>(3'4")</b>	2855 <b>(9'4")</b>	40.0 <b>(25.0)</b>	40.0 <b>(25.0)</b>	
936	33Z	83-87	125	11 884 <b>(26,200)</b>	2.1 <b>(2.75)</b>	12 514 <b>(28,708)</b>	2.56 <b>(8'4.5")</b>	329 <b>(13)</b>	1055 <b>(3'0")</b>	2.80 <b>(9'2")</b>	34.4 <b>(21.4)</b>	38.4 <b>(23.9)</b>	Box Frame
936E	33Z	87-92	135	12 300 <b>(27,000)</b>	2.3 <b>(3.0)</b>	12 920 <b>(28,483)</b>	2.56 <b>(8'5")</b>	379 <b>(14.9)</b>	1026 <b>(2'11")</b>	2.87 <b>(9'2")</b>	40.6 <b>(25.2)</b>	45.3 <b>(28.2)</b>	
936F	8AJ	92-94	140	12 300 <b>(27,060)</b>	2.3 <b>(3.0)</b>	12 920 <b>(28,483)</b>	2.58 <b>(8'5")</b>	379 <b>(14.9)</b>	997 <b>(3'3")</b>	2.84 <b>(9'4")</b>	42.3 <b>(26.3)</b>	46.7 <b>(29.6)</b>	
938F		94-97	140	13 030 <b>(28,730)</b>	2.5 <b>(3.25)</b>	12 330 <b>(27,180)</b>	2.61 <b>(8'7")</b>	400 <b>(16)</b>	1004 <b>(3'4")</b>	2.85 <b>(9'4")</b>	37.9 <b>(23.6)</b>	22.0 <b>(13.7)</b>	Wet Disc Brakes
938G	4YS	97-02	160	12 962 <b>(28,578)</b>	2.8 <b>(3.65)</b>	11 227 <b>(24,770)</b>	2.60 <b>(8'6")</b>	400 <b>(16)</b>	1055 <b>(3'6")</b>	2.72 <b>(8'11")</b>	39.4 <b>(24.5)</b>	23.4 <b>(14.5)</b>	
938G	CRD	02-07	160	13 452 <b>(29,656)</b>	2.8 <b>(3.66)</b>	11 156 <b>(24,594)</b>	2.60 <b>(8'6")</b>	400 <b>(16)</b>	1068 <b>(3'6")</b>	2.771 <b>(9'1")</b>	38.8 <b>(24.1)</b>	23.3 <b>(14.5)</b>	
Series II 938H	MJC	05-12	197	14 919 <b>(32,881)</b>	2.5 <b>(3.3)</b>	13 751 <b>(30,316)</b>	2.65 <b>(8'8")</b>	397 <b>(16)</b>	1019 <b>(3'4")</b>	2.849 <b>(9'4")</b>	41.1 <b>(25.5)</b>	25.0 <b>(15.5)</b>	
938K	SWL	11-15	173	15 928 <b>(35,104)</b>	2.5 <b>(3.3)</b>	13 170 <b>(29,027)</b>	2.675 <b>(8'9")</b>	390 <b>(15.3)</b>	1146 <b>(3'9")</b>	2834 <b>(9'3")</b>	40.0 <b>(25.0)</b>	40.0 <b>(25.0)</b>	
938K	XXT HFW	13-15	188	15 146 <b>(33,301)</b>	2.5 <b>(3.3)</b>	13 170 <b>(29,027)</b>	2.675 <b>(8'9")</b>	286 <b>(11.2)</b>	1108 <b>(3'7")</b>	2869 <b>(9'4")</b>	40.0 <b>(25.0)</b>	40.0 <b>(25.0)</b>	
944	87J	59-68	100	10 100 <b>(22,000)</b>	1.53 <b>(2.0)</b>	9800 <b>(21,700)</b>	2.40 <b>(7'10")</b>	450 <b>(18)</b>	905 <b>(3'0")</b>	2.96 <b>(9'9")</b>	38.5 <b>(23.9)</b>	46.6 <b>(28.9)</b>	Articulated Steering, 4 Wheel Drive Z Bar Linkage
950	81J	68-81	130	12 930 <b>(28,500)</b>	1.53 <b>(2.07)</b>	10 320 <b>(22,760)</b>	2.41 <b>(7'11")</b>	381 <b>(15)</b>	740 <b>(2'5")</b>	2.82 <b>(9'3")</b>	35.9 <b>(22.3)</b>	42.5 <b>(26.4)</b>	
950B	22Z	81-87	155	14 650 <b>(32,300)</b>	2.9 <b>(3.75)</b>	15 680 <b>(35,895)</b>	2.67 <b>(5'9")</b>	427 <b>(16.8)</b>	1125 <b>(3'8")</b>	2.95 <b>(9'8")</b>	36.4 <b>(22.6)</b>	39.4 <b>(24.5)</b>	
950E	22Z	87-91	160	15 856 <b>(34,883)</b>	3.1 <b>(4.0)</b>	13 586 <b>(29,925)</b>	2.76 <b>(9'0")</b>	400 <b>(15.7)</b>	1160 <b>(3'10")</b>	2.85 <b>(9'4")</b>	36.2 <b>(22.4)</b>	39.9 <b>(24.7)</b>	
950F	7ZF	90-92	170	16 086 <b>(35,463)</b>	3.1 <b>(4.0)</b>	14 954 <b>(32,974)</b>	2.76 <b>(9'0")</b>	474 <b>(18.7)</b>	1160 <b>(3'10")</b>	2.85 <b>(9'4")</b>	39.3 <b>(24.4)</b>	43.0 <b>(26.7)</b>	
950F	5SK	93-98	170	16 880 <b>(37,220)</b>	3.1 <b>(4.0)</b>	14 960 <b>(32,980)</b>	2.76 <b>(9'0")</b>	460 <b>(18.1)</b>	1180 <b>(3'10")</b>	2.83 <b>(9'3")</b>	38.7 <b>(24.0)</b>	42.7 <b>(26.5)</b>	
Series II 950G	3JW	98-02	183	16 904 <b>(37,266)</b>	3.5 <b>(4.5)</b>	14 888 <b>(32,810)</b>	2.89 <b>(9'6")</b>	400 <b>(16)</b>	1270 <b>(4'2")</b>	2.89 <b>(9'6")</b>	37.0 <b>(23.0)</b>	40.7 <b>(25.3)</b>	Integral ROPS Electronic Shift
950G	AXX	02-05	183	17 780 <b>(39,198)</b>	3.1 <b>(4.05)</b>	15 724 <b>(34,666)</b>	2.89 <b>(9'6")</b>	412 <b>(16.2)</b>	1202 <b>(3'11")</b>	2.92 <b>(9'7")</b>	37.0 <b>(23.0)</b>	40.0 <b>(24.9)</b>	

Wheel Loaders (cont'd)

Model	Product Ident. No. Prefix	Years Built	Flywheel Horse-power	Approx. Shipping Wt. kg (lb)	Rated Capacity m <sup>3</sup> (yd <sup>3</sup> )	Breakout Force kg (lb)	Width Over Tires m (ft)	Ground Clearance mm (in)	Max. Reach at max. height mm (ft)	Dump Clearance at max. height m (ft)	Maximum Speeds km/h (mph)		Remarks
											Fwd.	Rev.	
960F	9ZJ	94-98	200	18 070 <b>(39,840)</b>	3.5 <b>(4.5)</b>	14 500 <b>(31,970)</b>	2.77 <b>(9'1")</b>	454 <b>(179)</b>	1030 <b>(3'5")</b>	2.92 <b>(9'6")</b>	39.4 <b>(24.5)</b>	43.2 <b>(26.8)</b>	Material Handler
962G	4PW 5AS	98-02	200	17 941 <b>(39,553)</b>	3.8 <b>(5.0)</b>	14 480 <b>(31,950)</b>	2.90 <b>(9'8")</b>	400 <b>(16)</b>	1250 <b>(4'2")</b>	2.77 <b>(9'2")</b>	37.0 <b>(23.0)</b>	40.7 <b>(25.3)</b>	
962G	AXY	02-05	204	18 547	3.5	14 072	2.89	412	1308	2.81	37.0	40.0	
Series II	AXS			<b>(40,889)</b>	<b>(4.58)</b>	<b>(31,024)</b>	<b>(9'6")</b>	<b>(16.2)</b>	<b>(4'2")</b>	<b>(9'2")</b>	<b>(23.0)</b>	<b>(24.9)</b>	
966A	33A	60-63	140	13 060 <b>(28,800)</b>	2.10 <b>(2.75)</b>	13 470 <b>(29,700)</b>	2.70 <b>(8'10")</b>	450 <b>(18)</b>	900 <b>(3'0")</b>	2.95 <b>(9'8")</b>	43.0 <b>(26.7)</b>	51.5 <b>(32.3)</b>	
966B	75A	63-68	150	14 300 <b>(31,500)</b>	2.29 <b>(3.0)</b>	14 000 <b>(31,000)</b>	2.70 <b>(8'10")</b>	400 <b>(16)</b>	900 <b>(3'0")</b>	2.95 <b>(9'8")</b>	38.5 <b>(23.9)</b>	46.3 <b>(28.8)</b>	
966C	76J	68-81	170	16 730 <b>(36,890)</b>	3.1 <b>(4.0)</b>	11 600 <b>(25,578)</b>	2.77 <b>(9'1")</b>	400 <b>(15.7)</b>	1420 <b>(4'8")</b>	2.95 <b>(9'8")</b>	38.0 <b>(23.6)</b>	45.1 <b>(28.0)</b>	Z Bar Linkage
966D	99Y	80-87	200	19 730 <b>(43,500)</b>	3.3 <b>(4.25)</b>	20 972 <b>(48,150)</b>	2.86 <b>(9'4.8")</b>	451 <b>(17.8)</b>	1230 <b>(4'0")</b>	3.14 <b>(10'3.5")</b>	34.3 <b>(21.3)</b>	38.1 <b>(23.7)</b>	26.5-25 Std. Tires
966E	99Y	87-90	216	20 324 <b>(44,767)</b>	3.8 <b>(5.0)</b>	18 939 <b>(41,715)</b>	2.94 <b>(9'8")</b>	476 <b>(18.7)</b>	1290 <b>(4'3")</b>	2.97 <b>(9'9")</b>	38.2 <b>(23.7)</b>	43.6 <b>(27.0)</b>	
966F	4YG	90-93	220	20 466 <b>(45,119)</b>	3.8 <b>(5.0)</b>	20 493 <b>(45,187)</b>	2.94 <b>(9'8")</b>	476 <b>(18.7)</b>	1280 <b>(4'2")</b>	2.98 <b>(9'9")</b>	37.6 <b>(23.4)</b>	42.6 <b>(26.4)</b>	Wet Disc Brakes
966F	1SL	93-98	220	21 290 <b>(46,950)</b>	3.8 <b>(5.0)</b>	20 490 <b>(45,180)</b>	2.94 <b>(9'8")</b>	476 <b>(18.7)</b>	1277 <b>(4'2")</b>	2.98 <b>(9'9")</b>	38.8 <b>(24.1)</b>	43.9 <b>(27.3)</b>	Integral ROPS
Series II	3SW	98-02	235	22 068 <b>(48,651)</b>	4.0 <b>(5.25)</b>	19 986 <b>(44,120)</b>	2.97 <b>(9'9")</b>	565 <b>(22)</b>	1295 <b>(4'3")</b>	3.10 <b>(10'2")</b>	37.1 <b>(23.1)</b>	42.2 <b>(26.2)</b>	Electronic Shift
966G	3ZS			22 870 <b>(50,400)</b>	4.25 <b>(5.5)</b>	19 273 <b>(42,477)</b>	3.04 <b>(9'11")</b>	471 <b>(18.5)</b>	1328 <b>(4'4")</b>	3.07 <b>(10'0")</b>	37.2 <b>(23.1)</b>	38.5 <b>(23.9)</b>	
Series II	ANZ	01-05	246	22 870 <b>(50,400)</b>	4.25 <b>(5.5)</b>	19 273 <b>(42,477)</b>	3.04 <b>(9'11")</b>	471 <b>(18.5)</b>	1328 <b>(4'4")</b>	3.07 <b>(10'0")</b>	37.2 <b>(23.1)</b>	38.5 <b>(23.9)</b>	Advanced Power Train
966K	ANT	12-14	299	24 189 <b>(53,311)</b>	4.2 <b>(5.5)</b>	17 641 <b>(38,984)</b>	2.99 <b>(9'9")</b>	475 <b>(18.7)</b>	1388 <b>(4'6")</b>	2.99 <b>(9'9")</b>	40.0 <b>(24.9)</b>	28.0 <b>(17.4)</b>	
970F	7SK	93-98	250	23 690 <b>(52,240)</b>	4.7 <b>(6.0)</b>	16 510 <b>(36,400)</b>	2.94 <b>(9'8")</b>	482 <b>(19)</b>	1357 <b>(4'5")</b>	3.22 <b>(10'6")</b>	37.3 <b>(23.2)</b>	42.7 <b>(26.5)</b>	Material Handler New Model
972G	4WW 7LS	98-02	265	24 468 <b>(53,942)</b>	4.7 <b>(6.0)</b>	21 618 <b>(47,580)</b>	2.97 <b>(9'9")</b>	565 <b>(22)</b>	1255 <b>(4'1")</b>	3.15 <b>(10'4")</b>	37.0 <b>(22.9)</b>	41.9 <b>(26.0)</b>	
972G	AWP	01-05	270	25 490	4.7	22 036	2.95	565	1325	3.23	36.9	38.8	
Series II	ANY			<b>(56,180)</b>	<b>(6.0)</b>	<b>(48,554)</b>	<b>(9'9")</b>	<b>(22.2)</b>	<b>(4'4")</b>	<b>(10'7")</b>	<b>(22.9)</b>	<b>(24.0)</b>	
980	42H	66-70	235	20 000 <b>(44,000)</b>	3.06 <b>(4.0)</b>	18 860 <b>(41,570)</b>	2.87 <b>(9'5")</b>	399 <b>(16)</b>	1190 <b>(3'11")</b>	3.07 <b>(10'1")</b>	42.0 <b>(26.1)</b>	26.7 <b>(16.6)</b>	
980B	89P	70-78	260	23 360 <b>(51,500)</b>	3.44-4.21 <b>(4.5-5.5)</b>	15 900 <b>(35,100)</b>	3.11 <b>(10'2")</b>	— <b>(—)</b>	1120 <b>(3'8")</b>	3.20 <b>(10'6")</b>	43.0 <b>(26.7)</b>	27.4 <b>(17.0)</b>	
980C	63X	79-91	270	27 559 <b>(60,755)</b>	5.2 <b>(6.75)</b>	23 188 <b>(51,121)</b>	3.15 <b>(10'4")</b>	417 <b>(16.4)</b>	1480 <b>(4'10")</b>	3.19 <b>(10'6")</b>	34.6 <b>(21.5)</b>	39.6 <b>(24.5)</b>	Dual Z Bar Linkage
980F	8JN	91-92	275	27 580 <b>(60,800)</b>	5.3 <b>(7.0)</b>	23 188 <b>(51,121)</b>	3.15 <b>(10'4")</b>	469 <b>(18.5)</b>	1500 <b>(4'11")</b>	3.16 <b>(10'5")</b>	37.4 <b>(23.2)</b>	42.8 <b>(26.6)</b>	Electronic Shift
980F	4RN	92-95	275	27 580 <b>(60,800)</b>	5.3 <b>(7.0)</b>	23 188 <b>(51,121)</b>	3.15 <b>(10'4")</b>	469 <b>(18.5)</b>	1500 <b>(4'11")</b>	3.16 <b>(10'5")</b>	37.4 <b>(23.2)</b>	42.8 <b>(26.6)</b>	
Series II	2KR	95-01	300	29 480 <b>(65,000)</b>	5.4 <b>(7.0)</b>	23 760 <b>(52,390)</b>	3.25 <b>(10'8")</b>	467 <b>(18.4)</b>	1540 <b>(5'1")</b>	3.27 <b>(10'8")</b>	37.4 <b>(23.2)</b>	42.8 <b>(26.6)</b>	
980G	AWH	01-05	311	30 207 <b>(66,576)</b>	5.7 <b>(7.5)</b>	21 414 <b>(47,277)</b>	3.25 <b>(10'8")</b>	467 <b>(18.4)</b>	1545 <b>(5'1")</b>	3.27 <b>(10'9")</b>	37.4 <b>(23.2)</b>	42.8 <b>(26.6)</b>	
Series II													

Wheel Loaders (cont'd)

Model	Product Ident. No. Prefix	Years Built	Flywheel Horse-power	Approx. Shipping Wt. kg (lb)	Rated Capacity m <sup>3</sup> (yd <sup>3</sup> )	Breakout Force kg (lb)	Width Over Tires m (ft)	Ground Clearance mm (in)	Max. Reach at max. height mm (ft)	Dump Clearance at max. height m (ft)	Maximum Speeds km/h (mph)		Remarks
											Fwd.	Rev.	
988	87A	63-76	325	35 800 (79,000)	4.6-5.4 (6.0-7.0)	21 380 (47,130)	3.20 (10'7")	570 (22.5)	1450 (4'9")	3.33 (10'11")	30.6 (19.0)	30.6 (19.0)	
988B	50W	76-93	375	43 365 (95,600)	5.4-6.3 (7.0-8.25)	36 330 (80,100)	3.52 (11'7")	474 (18)	2150 (7'1")	3.19 (10'5")	36.2 (22.5)	41.4 (25.7)	3408 Engine Z Bar Linkage
988F	8YG	93-95	400	43 540 (95,900)	5.4-6.1 (7.0-8.0)	37 363 (82,371)	3.52 (11'7")	496 (19)	1830 (6'0")	3.21 (10'6")	35.1 (21.8)	23.5 (14.6)	Bucket/HP increase STIC™ Steer
988F	2ZR	95-00	475	45 678 (100,492)	6.1-6.9 (8.0-9.0)	37 400 (82,282)	3.52 (11'7")	496 (19)	1611 (5'3")	3.22 (10'7")	35.1 (21.8)	35.1 (14.6)	3408E Engine Axle Shaft Brakes
988G	2TW BNH	01-05	475	50 040 (110,320)	6.3-7.0 (8.2-9.2)	46 950 (103,500)	3.47 (11'5")	549 (21.6)	2113 (6'11")	4.00 (13'1")	38.7 (24.0)	22.3 (13.8)	4.25 m 6 Bar Linkage
988H	BXY A7A	05-15	501	50 144 (110,549)	6.4-7.7 (8.3-10)	41 531 (91,560)	3.47 (11'5")	549 (21.6)	2153 (7'1")	3.31 (10'10")	38.6 (24.0)	25.5 (15.6)	3.88 m 6 Bar Linkage
990	7HK	93-95	610	72 910 (160,600)	8.6 (11.2)	59 776 (131,784)	4.13 (13'6")	552 (21.7)	2070 (6'10")	3.99 (13'1")	22.5 (14.0)	25.0 (15.5)	ICTC & New Model
990	4FR	96-05	625	72 200 (159,170)	8.4-9.2 (11-12)	63 100 (138,800)	4.00 (13'1")	490 (19.3)	1990 (6'6")	4.05 (13'3")	22.5 (14.0)	25.0 (15.5)	3412E Engine
990H	BWX	05-14	627	77 842 (171,642)	8.6-9.2 (11.25-12)	602 (135,429)	4.16 (13'3")	478 (18.8)	8.07 (26'6")	4220 (13'10")	22.4 (13.92)	24.8 (15.41)	Standard Lift 8.6 m <sup>3</sup> /11.2 yd <sup>3</sup> Bucket
992	25K	68-73	550	47 670 (105,100)	7.65 (10.0)	36 900 (81,360)	3.93 (12'11")	530 (21)	2820 (8'3")	4.52 (14'10")	35.6 (22.1)	38.5 (23.8)	
992B	25K	73-77	550	64 320 (141,800)	7.65 (10.0)	29 330 (64,660)	— (—)	— (—)	1930 (6'4")	4.34 (14'3")	40.2 (25.0)	43.6 (27.1)	
992C	42X	77-81	690	85 640 (188,800)	9.6 (12.5)	66 240 (146,030)	4.55 (14'11")	533 (21)	2310 (7'7")	4.17 (13'8")	21.1 (13.1)	23.3 (14.5)	3412 PCT Engine Z Bar Linkage
992C	49Z	81-92	690	88 430 (194,950)	10.4 (13.5)	66 285 (146,132)	4.50 (14'9")	544 (21)	2310 (7'7")	4.17 (13'8")	21.0 (13.0)	22.9 (14.2)	3412 DIT Engine
992D	7MJ	92-97	710	88 690 (195,125)	10.7 (14.0)	62 670 (137,870)	4.50 (14'9")	544 (21)	2300 (7'7")	4.17 (13'8")	21.0 (13.0)	22.9 (14.2)	
992G	7HR	98-00	800	91 540 (201,810)	11.5-12.3 (15-16)	62 650 (137,840)	4.50 (14'9")	691 (27.2)	2300 (7'7")	4.60 (15'3")	20.2 (12.5)	22.7 (14.1)	6 Bar Linkage "G" Series
992K	H4C	07-11	801	97 294 (214,535)	10.7-12.3 (14-16)	584.66 (128,917)	— (—)	682 (26)	9313 (30'6")	4480 (14'8")	20.6 (12.8)	22.4 (13.9)	10.7 m <sup>3</sup> /14 yd <sup>3</sup> Bucket
992K	ZMX 880	11-16	801	97 294 (214,535)	10.7-12.3 (14-16)	584.66 (128,917)	— (—)	682 (26)	9313 (30'6")	4480 (14'8")	20.6 (12.8)	22.4 (13.9)	10.7 m <sup>3</sup> /14 yd <sup>3</sup> Bucket
993K	Z9K	07-12	945	133 637 (294,800)	12.8-14.5 (16.7-19)	72 347 (159,500)	4.93 (16'2")	783 (30.8)	9313 (30'7")	4849 (15'11")	20.1 (22.1)	12.5 (13.7)	12.8 m <sup>3</sup> /16.7 yd <sup>3</sup> Bucket
994	9YF	90-98	1250	177 000 (390,300)	10.3 (13.4)	103 420 (228,000)	5.20 (17'1")	662 (26)	2692 (8'10")	6.20 (20'4")	24.7 (15.0)	26.6 (16.5)	
994D	3TZ	98-05	1250	191 200 (420,640)	17.0 (22.5)	96 939 (213,265)	5.4 (17'8")	676 (26)	2157 (7'1")	5698 (18'8")	24.1 (15.0)	26.6 (16.5)	
994F	442	05-11	1577	195 434 (429,955)	18.0 (23.5)	104 082 (229,305)	5.4 (17'8")	811 (32)	2721 (8'11")	6002 (19'8")	24 (14.9)	25.6 (15.9)	Ext. High Lift Available
994H	DWC	11-14	1577	195 434 (429,955)	18.0 (23.5)	104 082 (229,305)	5.4 (17'8")	811 (32)	2721 (8'11")	6002 (19'8")	24 (14.9)	25.6 (15.9)	Ext. High Lift Available



## TRACK LOADERS

Model	Product Ident. No. Prefix	Years Built	Flywheel Horsepower	Approx. Operating Weight kg (lb)	Rated Capacity m <sup>3</sup> (yd <sup>3</sup> )	Dimensions			Remarks
						Length** m (ft)	Width m (ft)	Height m (ft)	
931	78U	72-79	62	6940 <b>(15,300)</b>	0.77 <b>(1.0)</b>	2.74 <b>(9'0")</b>	1.78 <b>(5'10")</b>	1.96 <b>(6'5")</b>	
931 LGP	10N	75-79	62	7498 <b>(16,530)</b>	1.15 <b>(1.5)</b>	2.74 <b>(9'0")</b>	2.29 <b>(7'6")</b>	1.98 <b>(6'6")</b>	
931B	29Y	79-88	65	7362 <b>(16,230)</b>	0.8 <b>(1.0)</b>	4.13 <b>(13'9")</b>	1.84 <b>(6'0.5")</b>	2.68 <b>(8'10")</b>	
931B LGP	30Y	79-88	65	8089 <b>(17,834)</b>	0.8 <b>(1.0)</b>	3.84 <b>(12'7")</b>	2.41 <b>(7'11")</b>	2.68 <b>(8'10")</b>	
931C	2BJ1		67	7595 <b>(16,743)</b>	0.77 <b>(1.0)</b>	2.74 <b>(9'0")</b>	1.78 <b>(5'10")</b>	2.68 <b>(8'10")</b>	
931C LGP	7HF 6RF1		67	8170 <b>(18,012)</b>	0.77 <b>(1.0)</b>	2.74 <b>(9'0")</b>	1.78 <b>(5'10")</b>	2.68 <b>(8'10")</b>	
931C Series II	8AF 9AG 6AJ	90-93	70	8047 <b>(17,742)</b>	0.83 <b>(1.08)</b>	4.14 <b>(13'1")</b>	1.97 <b>(6'5")</b>	2.68 <b>(8'10")</b>	
933C	11A	55-58	50	7030 <b>(15,500)</b>	0.77 <b>(1.0)</b>	4.22 <b>(13'10")</b>	1.77 <b>(5'10")</b>	1.91 <b>(6'4")</b>	Integral loader
933E	11A	58-65	50	7640 <b>(16,850)</b>	0.77 <b>(1.0)</b>	4.22 <b>(13'10")</b>	1.77 <b>(5'10")</b>	1.40 <b>(6'3")</b>	Integral loader
933G	42A	65-68	60	7900 <b>(17,500)</b>	0.86 <b>(1.125)</b>	4.31 <b>(14'2")</b>	1.77 <b>(5'10")</b>	2.15 <b>(7'1")</b>	Patented Sealed Track
935B	30F	87-88	75	7899 <b>(17,414)</b>	1.0 <b>(1.25)</b>	4.19 <b>(13'9")</b>	1.96 <b>(6'5")</b>	2.68 <b>(8'10")</b>	
935C	8CF		78	8205 <b>(18,089)</b>	1.0 <b>(1.3)</b>	4.19 <b>(13'9")</b>	1.96 <b>(6'5")</b>	2.68 <b>(8'10")</b>	
935C Series II	SDJ	90-93	80	8759 <b>(19,311)</b>	1.0 <b>(1.3)</b>	4.37 <b>(14'4")</b>	1.97 <b>(6'5")</b>	2.68 <b>(8'10")</b>	
939C	6DS	96-01	90	9578 <b>(21,072)</b>	1.2 <b>(1.5)</b>	4.36 <b>(14'4")</b>	1.96 <b>(6'5")</b>	2.77 <b>(9'1")</b>	
941	80H	68-72	70	8900 <b>(19,700)</b>	0.96 <b>(1.25)</b>	4.50 <b>(14'10")</b>	1.86 <b>(6'1")</b>	2.75 <b>(9'0")*</b>	Electric Start
941B	80H	68-81	80	11 294 <b>(24,900)</b>	1.15 <b>(1.5)</b>	4.50 <b>(14'10")</b>	1.98 <b>(6'6")</b>	2.75 <b>(9'0")*</b>	HP Increase, Hydraulic Track Adjusters
943	31Y	80-85	80	11 750 <b>(25,900)</b>	1.15 <b>(1.5)</b>	5.426 <b>(17'10")</b>	2.21 <b>(8'7")</b>	3.02 <b>(9'11")</b>	Hydrostatic drive
943	19Z	80-92	80	11 750 <b>(25,900)</b>	1.15 <b>(1.5)</b>	5.426 <b>(17'10")</b>	2.21 <b>(8'7")</b>	3.02 <b>(9'11")</b>	Hydrostatic drive made in France

\*Height to top of stack. Others to top of seat back.

\*\*Overall length to tip of smallest General Purpose bucket.

## Track Loaders (cont'd)

Model	Product Ident. No. Prefix	Years Built	Flywheel Horsepower	Approx. Operating Weight kg (lb)	Rated Capacity m <sup>3</sup> (yd <sup>3</sup> )	Dimensions			Remarks
						Length** m (ft)	Width m (ft)	Height m (ft)	
951B	79H	67-71	85	10 025 <b>(22,100)</b>	1.14 <b>(1.5)</b>	4.70 <b>(15'6")</b>	1.98 <b>(6'6")</b>	2.75 <b>(9'0")*</b>	Pedal Steering HP Increase, Sealed & Lubricated Track
951C	86J	71-81	95	12 338 <b>(27,200)</b>	1.34 <b>(1.75)</b>	4.77 <b>(15'8")</b>	1.98 <b>(6'6")</b>	2.75 <b>(9'0")*</b>	
953	5Z	81-85	110	14 050 <b>(31,000)</b>	1.5 <b>(2.0)</b>	5.87 <b>(19'3")</b>	2.38 <b>(7'10")</b>	3.08 <b>(10'1")</b>	Hydrostatic drive
953	20Z	81-92	110	14 050 <b>(31,000)</b>	1.5 <b>(2.0)</b>	5.87 <b>(19'3")</b>	2.38 <b>(7'10")</b>	3.08 <b>(10'1")</b>	Hydrostatic drive
953	76Y	81-85	110	13 800 <b>(30,500)</b>	1.5 <b>(2.0)</b>	5.87 <b>(19'3")</b>	2.38 <b>(7'10")</b>	3.08 <b>(10'1")</b>	Hydrostatic drive
953	77Y	81-85	110	13 800 <b>(30,500)</b>	1.5 <b>(2.0)</b>	5.87 <b>(19'3")</b>	2.38 <b>(7'10")</b>	3.08 <b>(10'1")</b>	Hydrostatic drive
953B	5MK	92-96	120	14 400 <b>(31,800)</b>	1.75 <b>(2.25)</b>	4.23 <b>(13'4")</b>	2.38 <b>(7'10")</b>	3.08 <b>(10'1")</b>	Hydrostatic drive
953C	2ZN	96-03	121	14 680 <b>(32,360)</b>	2.3 <b>(3.0)</b>	4.35 <b>(14'3")</b>	2.30 <b>(7'7")</b>	3.08 <b>(10'1")</b>	SystemOne™ U/C
953C	BBX	03-07	128	15 145 <b>(33,389)</b>	1.75 <b>(2.25)</b>	4.35 <b>(14'3")</b>	2.30 <b>(7'7")</b>	3.16 <b>(10'4")</b>	
HT4	7U	50-55	54	2607 <b>(5748)</b>	0.96 <b>(1.25)</b>	4.32 <b>(14'2")</b>	2.03 <b>(6'8")</b>	1.83 <b>(6'0")</b>	Integral loader
955C	12A	55-60	70	9590 <b>(21,145)</b>	1.15 <b>(1.5)</b>	4.60 <b>(15'2")</b>	2.03 <b>(6'8")</b>	2.08 <b>(6'11")</b>	
955E	12A	58-60	70	10 160 <b>(22,400)</b>	1.15 <b>(1.5)</b>	4.60 <b>(15'2")</b>	2.03 <b>(6'8")</b>	2.09 <b>(6'11")</b>	Improved undercarriage
955H	60A	60-66	100	11 320 <b>(24,950)</b>	1.34 <b>(1.75)</b>	4.79 <b>(15'9")</b>	1.90 <b>(6'3")</b>	2.65 <b>(8'8")*</b>	Power shift, Turbo, oil cooled brakes
955K	61H	66-71	115	12 700 <b>(28,000)</b>	1.34 <b>(1.75)</b>	5.00 <b>(16'6")</b>	2.06 <b>(6'9")</b>	2.80 <b>(9'3")*</b>	Horsepower and bucket capacity increase
955L	85J	71-75	130	15 330 <b>(33,800)</b>	1.53 <b>(2.0)</b>	5.30 <b>(16'1")</b>	2.18 <b>(7'2")</b>	2.95 <b>(9'8")*</b>	ROPS Cab, Sealed & Lubricated Track
955L	13X	75-81	130	15 853 <b>(34,950)</b>	1.72 <b>(2.25)</b>	5.26 <b>(17'3")</b>	2.18 <b>(7'2")</b>	2.95 <b>(9'8")</b>	

\*Height to top of stack. Others to top of seat back.

\*\*Overall length to tip of smallest General Purpose bucket.

## Track Loaders (cont'd)

Model	Product Ident. No. Prefix	Years Built	Flywheel Horsepower	Approx. Operating Weight kg (lb)	Rated Capacity m <sup>3</sup> (yd <sup>3</sup> )	Dimensions			Remarks
						Length** m (ft)	Width m (ft)	Height m (ft)	
963	6Z	81-85	150	18 250 <b>(40,250)</b>	2.0 <b>(2.6)</b>	6.35 <b>(20'10")</b>	2.50 <b>(8'2")</b>	3.30 <b>(10'10")</b>	Hydrostatic drive
963	11Z	81-85	150	18 370 <b>(40,490)</b>	2.0 <b>(2.6)</b>	6.35 <b>(20'10")</b>	2.50 <b>(8'2")</b>	3.30 <b>(10'10")</b>	Hydrostatic drive
963	18Z	82-86	150	18 250 <b>(40,250)</b>	2.0 <b>(2.6)</b>	6.35 <b>(20'10")</b>	2.50 <b>(8'2")</b>	3.30 <b>(10'10")</b>	Hydrostatic drive made in France
963	21Z	82-95	150	18 370 <b>(40,490)</b>	2.0 <b>(2.6)</b>	6.35 <b>(20'10")</b>	2.50 <b>(8'2")</b>	3.30 <b>(10'10")</b>	Hydrostatic drive made in France
963B	9BL	95-99	160	19 620 <b>(43,270)</b>	2.45 <b>(3.2)</b>	6.60 <b>(21'8")</b>	2.50 <b>(8'2")</b>	3.31 <b>(10'10")</b>	3116 engine
963C	2DS	99-03	160	19 020 <b>(41,940)</b>	1.75 <b>(2.25)</b>	4.61 <b>(15'2")</b>	2.40 <b>(7'11")</b>	3.32 <b>(10'11")</b>	
963C	BBD	03-07	158	19 589 <b>(43,096)</b>	2.45 <b>(3.2)</b>	4.61 <b>(15'2")</b>	2.40 <b>(7'11")</b>	3.39 <b>(11'2")</b>	SystemOne U/C
973	86G	81-00	210	25 040 <b>(55,200)</b>	3.2 <b>(4.2)</b>	7.12 <b>(23'4")</b>	2.85 <b>(9'4")</b>	3.42 <b>(11'3")</b>	
973C	3RZ	99-01	210	27 006 <b>(59,548)</b>	3.2 <b>(4.19)</b>	7.36 <b>(24'2")</b>	2.58 <b>(8'6")</b>	3.50 <b>(11'6")</b>	
973C	BCP	01-05	230	27 006 <b>(59,548)</b>	3.2 <b>(4.19)</b>	7.36 <b>(24'2")</b>	2.58 <b>(8'6")</b>	3.50 <b>(11'6")</b>	
No. 6	10A	53-55	80	13 229 <b>(29,165)</b>	1.5 <b>(2.0)</b>	4.90 <b>(16'1")</b>	2.44 <b>(8'1")</b>	2.11 <b>(6'11")</b>	
977D	20A	55-60	100	14 430 <b>(31,795)</b>	1.72 <b>(2.25)</b>	5.19 <b>(18'0")</b>	2.44 <b>(8'0")</b>	2.22 <b>(7'4")</b>	
977E	20A	58-60	100	15 850 <b>(34,910)</b>	1.72 <b>(2.25)</b>	5.19 <b>(18'0")</b>	2.44 <b>(8'0")</b>	2.29 <b>(7'7")</b>	Improved undercarriage
977H	53A	60-66	150	17 000 <b>(37,500)</b>	1.90 <b>(2.5)</b>	5.28 <b>(17'4")</b>	2.44 <b>(8'0")</b>	2.29 <b>(7'7")</b>	Power shift, Turbo, oil cooled brakes
977K	46H	66-78	170	19 100 <b>(42,000)</b>	1.90 <b>(2.5)</b>	5.50 <b>(18'0")</b>	2.38 <b>(7'10")</b>	3.05 <b>(10'0")*</b>	Walk-through compartment, longer roller frame
977L	14X	78-82	190	21 780 <b>(48,010)</b>	2.10 <b>(2.75)</b>	5.59 <b>(18'4")</b>	2.38 <b>(7'10")</b>	3.32 <b>(10'11")*</b>	Horsepower and bucket capacity increase
983	38K	69-78	275	34 460 <b>(75,980)</b>	3.82 <b>(5.0)</b>	6.78 <b>(22'3")</b>	2.90 <b>(9'6")</b>	2.79 <b>(11'10")*</b>	
983B	58X	78-82	275	35 620 <b>(78,530)</b>	3.82 <b>(5.0)</b>	6.78 <b>(22'3")</b>	2.90 <b>(9'6")</b>	3.68 <b>(12'1")*</b>	DI engine

\*Height to top of stack. Others to top of seat back.

\*\*Overall length to tip of smallest General Purpose bucket.





INTEGRATED TOOLCARRIERS

Model	Product Ident. No. Prefix	Years Built	Flywheel Horse-power	Approx. Operating Weight kg (lb)	Rated Capacity m <sup>3</sup> (yd <sup>3</sup> )	Breakout Force kg (lb)	Width Over Tires m (ft)	Ground Clearance mm (in)	Max. Reach at Max. Height mm (in)	Dump Clearance at Max. Height m (ft)	Maximum Speeds km/h (mph)		Remarks
											Fwd.	Rev.	
IT12	2YC	84-89	65	7393 <b>(16,299)</b>	1.0 <b>(1.25)</b>	7193 <b>(15,858)</b>	2.3 <b>(7'8")</b>	405 <b>(15.9)</b>	873 <b>(34)</b>	2.84 <b>(9'4")</b>	23.6 <b>(14.6)</b>	24.9 <b>(15.4)</b>	
IT12B	1KF	89-93	78	7950 <b>(17,530)</b>	1.2 <b>(1.6)</b>	6160 <b>(13,583)</b>	2.15 <b>(7'1")</b>	343 <b>(13.5)</b>	958 <b>(37.7)</b>	2.69 <b>(8'10")</b>	34.0 <b>(21.1)</b>	22.4 <b>(13.9)</b>	
IT12F	1KF	93-95	80	7893 <b>(17,401)</b>	1.3 <b>(1.7)</b>	6479 <b>(14,247)</b>	2.15 <b>(7'1")</b>	365 <b>(14)</b>	917 <b>(37)</b>	2.74 <b>(8'11.8")</b>	34.0 <b>(21.1)</b>	22.4 <b>(13.9)</b>	
IT14B	3NJ	89-93	85	8333 <b>(18,374)</b>	1.2 <b>(1.6)</b>	7525 <b>(16,593)</b>	2.15 <b>(7'1")</b>	344 <b>(13.6)</b>	958 <b>(37.7)</b>	2.70 <b>(8'11")</b>	37.3 <b>(23.2)</b>	24.4 <b>(15.2)</b>	
IT14F	4EL	93-95	85	7999 <b>(17,635)</b>	1.3 <b>(1.7)</b>	7170 <b>(15,808)</b>	2.15 <b>(7'1")</b>	365 <b>(14)</b>	918 <b>(37)</b>	2.74 <b>(9'0")</b>	37.3 <b>(23.2)</b>	24.4 <b>(15.2)</b>	
IT14G	1WN 8ZM FWL KZN	95-14	95	8450 <b>(18,632)</b>	1.2-1.4 <b>(1.6-1.8)</b>	7700 <b>(17,342)</b>	2.258 <b>(7'5")</b>	456 <b>(16.3)</b>	787 <b>(31)</b>	2.921 <b>(9'7")</b>	32.0 <b>(20.0)</b>	32.0 <b>(20.0)</b>	C4.4 ACERT Engine IT Linkage HystatTransmission
IT14G2	ERP	12-14	95	8450 <b>(18,632)</b>	1.2-1.4 <b>(1.6-1.8)</b>	7700 <b>(17,342)</b>	2.258 <b>(7'5")</b>	456 <b>(16.3)</b>	787 <b>(31)</b>	2.921 <b>(9'7")</b>	32.0 <b>(20.0)</b>	32.0 <b>(20.0)</b>	C4.4 ACERT Engine IT Linkage HystatTransmission
IT18	9NB	84-86	85	8660 <b>(19,092)</b>	1.2 <b>(1.5)</b>	9105 <b>(20,108)</b>	2.4 <b>(7'10")</b>	285 <b>(11.2)</b>	990 <b>(39)</b>	2.84 <b>(9'4")</b>	25.0 <b>(15.5)</b>	25.0 <b>(15.5)</b>	
IT18B	4ZD	86-92	95	9770 <b>(21,540)</b>	1.3 <b>(1.75)</b>	10 500 <b>(21,350)</b>	2.28 <b>(7'6")</b>	324 <b>(12.8)</b>	993 <b>(39)</b>	2.89 <b>(9'6")</b>	26.4 <b>(16.4)</b>	27.7 <b>(17.2)</b>	
IT18F	6ZF	92-94	105	9959 <b>(21,960)</b>	1.6 <b>(2.0)</b>	8880 <b>(19,580)</b>	2.33 <b>(7'8")</b>	321 <b>(13)</b>	1089 <b>(43)</b>	2.75 <b>(9'0")</b>	37.0 <b>(23.0)</b>	24.5 <b>(15.2)</b>	
IT24F	4NN	94-99	105	9989 <b>(20,022)</b>	1.7 <b>(2.5)</b>	8782 <b>(19,361)</b>	2.33 <b>(7'6")</b>	321 <b>(12.6)</b>	1088 <b>(42)</b>	2.75 <b>(9'0")</b>	38.0 <b>(23.6)</b>	23.4 <b>(14.8)</b>	
IT28	2KC	84-86	105	9560 <b>(21,076)</b>	1.5 <b>(2.0)</b>	9505 <b>(20,955)</b>	2.4 <b>(7'10")</b>	285 <b>(11.2)</b>	1044 <b>(41)</b>	2.82 <b>(9'3")</b>	30.8 <b>(18.8)</b>	32.3 <b>(20.0)</b>	
IT28B	1HF	86-93	110	10 580 <b>(23,325)</b>	1.7 <b>(2.25)</b>	10 456 <b>(23,050)</b>	2.32 <b>(7'7")</b>	324 <b>(12.8)</b>	1091 <b>(43)</b>	2.73 <b>(8'11")</b>	34.4 <b>(21.4)</b>	37.2 <b>(23.1)</b>	
IT28F	3CL	93-96	125	11 430 <b>(25,200)</b>	2.0 <b>(2.6)</b>	9840 <b>(21,700)</b>	2.43 <b>(8'0")</b>	317 <b>(12)</b>	1093 <b>(43)</b>	2.72 <b>(8'11")</b>	35.4 <b>(21.9)</b>	21.4 <b>(13.5)</b>	
IT28G	DBT	02-04	146	12 640 <b>(27,860)</b>	2.0 <b>(2.6)</b>	10 631 <b>(23,437)</b>	2.54 <b>(8'4")</b>	407 <b>(16)</b>	958 <b>(38)</b>	2.97 <b>(9'9")</b>	37.7 <b>(23.4)</b>	25.8 <b>(16.0)</b>	
IT28G	EWF	02-05	131	11 250 <b>(24,802)</b>	2.0 <b>(2.6)</b>	11 723 <b>(25,849)</b>	2.44 <b>(8'0")</b>	408 <b>(16)</b>	1455 <b>(57)</b>	2.879 <b>(9'5")</b>	37.7 <b>(23.4)</b>	25.8 <b>(16.0)</b>	
IT28G	WAC	02-05	131	11 250 <b>(24,802)</b>	2.0 <b>(2.6)</b>	11 723 <b>(25,849)</b>	2.44 <b>(8'0")</b>	408 <b>(16)</b>	1455 <b>(57)</b>	2.879 <b>(9'5")</b>	37.7 <b>(23.4)</b>	25.8 <b>(16.0)</b>	
IT38G	CSX	02-07	160	14 583 <b>(32,156)</b>	2.8 <b>(3.66)</b>	11 216 <b>(24,729)</b>	2.6 <b>(102)</b>	400 <b>(16)</b>	1224 <b>(48)</b>	2.733 <b>(108)</b>	38.8 <b>(24.1)</b>	23.3 <b>(14.5)</b>	
Series II IT38H	JNJ	07-12	200	16 000 <b>(35,274)</b>	3.0 <b>(3.92)</b>	12 797 <b>(28,214)</b>	2.67 <b>(8'9")</b>	400 <b>(16)</b>	1152 <b>(45)</b>	2.81 <b>(9'2")</b>	43.2 <b>(26.8)</b>	25.5 <b>(15.8)</b>	
950F CT	5SK	94-98	170	16 600 <b>(36,580)</b>	3.1 <b>(4.0)</b>	13 590 <b>(29,950)</b>	2.87 <b>(9'5")</b>	460 <b>(18)</b>	1714 <b>(68)</b>	2.845 <b>(9'4")</b>	38.7 <b>(24.0)</b>	42.7 <b>(26.5)</b>	



**TELEHANDLERS**

Model	Product Ident. No. Prefix	Years Built	Flywheel Horsepower kW (hp)	Operating Weight kg (lb)	Engine	Maximum Lift Height m (ft/in)	Maximum Reach m (ft/in)	Maximum Lift Capacity kg (lb)
TH62	4TM	00-02	72 <b>(105)</b>	6840 <b>(15,080)</b>	Cat 3054T	7.6 <b>(25'0")</b>	4.2 <b>(13'9")</b>	2725 <b>(6000)</b>
TH63	5WM	00-02	72 <b>(105)</b>	9260 <b>(20,420)</b>	Cat 3054T	12.5 <b>(41'0")</b>	8.1 <b>(26'7")</b>	3000 <b>(6615)</b>
TH82	3JN	00-02	72 <b>(105)</b>	7470 <b>(16,470)</b>	Cat 3054T	7.6 <b>(25'0")</b>	4.2 <b>(13'9")</b>	3635 <b>(8000)</b>
TH83	3RN	00-02	72 <b>(105)</b>	10 000 <b>(22,050)</b>	Cat 3054T	12.5 <b>(41'0")</b>	8.2 <b>(27'0")</b>	3635 <b>(8000)</b>
TH103	3PN	00-02	72 <b>(105)</b>	12 500 <b>(27,500)</b>	Cat 3054T	13.5 <b>(44'0")</b>	8.8 <b>(28'9")</b>	4536 <b>(10,000)</b>
TH210	MHT	03-06	60 <b>(80)</b>	5000 <b>(11,023)</b>	Cat 3054B DI	5.18 <b>(17'0")</b>	2.8 <b>(9'2")</b>	2200 <b>(4840)</b>
TH215	MHS	03-06	60 <b>(80)</b>	5500 <b>(12,100)</b>	Cat 3054B DI	5.54 <b>(18'2")</b>	3.1 <b>(10'2")</b>	2500 <b>(5500)</b>
TH220B	SLA/TBF	03-07	74.5 <b>(100)</b>	6700 <b>(14,774)</b>	Cat 3054E	6.1 <b>(20'0")</b>	3.3 <b>(10'9")</b>	3500 <b>(7718)</b>
TH330B	SLB/TBG	03-07	74.5 <b>(100)</b>	7200 <b>(15,876)</b>	Cat 3054E	7.2 <b>(23'7")</b>	3.8 <b>(12'6")</b>	3600 <b>(7938)</b>
TH340B	SLC	03-06	74.5 <b>(99.9)</b>	7700 <b>(17,000)</b>	Cat 3054E	9.0 <b>(29'6")</b>	6.5 <b>(21'4")</b>	3000 <b>(6600)</b>
TH350B	SLD	03-06	74.5 <b>(99.9)</b>	8480 <b>(18,100)</b>	Cat 3054E	11.0 <b>(36'0")</b>	7.4 <b>(24'0")</b>	3000 <b>(6600)</b>
TH360B	SLE/TBH	03-07	74.5 <b>(100)</b>	9970 <b>(21,984)</b>	Cat 3054E	13.5 <b>(44'3")</b>	9.2 <b>(30'2")</b>	3500 <b>(7718)</b>
TH460B	SLF	03-06	74.5 <b>(99.9)</b>	10 500 <b>(21,600)</b>	Cat 3054E	13.5 <b>(44'4")</b>	9.2 <b>(30'0")</b>	4000 <b>(8800)</b>
TH560B	SLG/TBP	03-07	74.5 <b>(99.9)</b>	12 000 <b>(26,500)</b>	Cat 3054E	13.5 <b>(44'0")</b>	9.2 <b>(30'0")</b>	5000 <b>(11,000)</b>
TH580B	SLH/TBJ	03-07	74.5 <b>(99.9)</b>	13 670 <b>(30,100)</b>	Cat 3054E	17 <b>(56'0")</b>	12.7 <b>(42'0")</b>	5000 <b>(11,000)</b>

## Former Models

## Paving Products

- Cold Planers
- Reclaimers & Stabilizers



### PAVING PRODUCTS – COLD PLANERS

Model	Product Ident. No. Prefix	Years Built	kW Flywheel (Horsepower)	Approximate Operating Weight kg (lb)	General Dimensions (Shipping)		
					Height mm (ft)	Length mm (ft)	Width mm (ft)
PR-75		85-92	52 (77)	5900 (13,000)	2690 (8'10")	3050 (10'0")	2130 (7'0")
PR-105		85-92	67 (90)	7711 (17,000)	2921 (9'7")	3581 (11'9")	2515 (8'3")
PR-275	6RC	—	201 (270)	17 237 (38,000)	2896 (9'6")	5740 (18'10")	2438 (8'0")
PR-450		85-92	336 (450)	28 308 (58,000)	4270 (14'0")	13 280 (43'8")	2870 (9'5")
PR-450C		92-97	336 (450)	28 308 (58,000)	3810 (12'6")	13 200 (43'6")	2490 (8'2")
PR-750B		85-92	559 (750)	42 638 (94,000)	3734 (12'3")	16 500 (54'0")	3575 (11'9")
PR-1000			Cutter 559 (750) Track 186 (250)	46 780 (103,130)	3810 (12'6")	16 590 (54'5")	4877 (16'0")
PM-465	5ZS	97-03	353 (473)	14 333 (31,600)	2820 (9'3")	13 716 (45'0")	2489 (8'2")
PM-565		xx-05	466 (625)	38 595 (85,100)	5040 (16'6")	15 100 (49'5")	2790 (9'2")
PM201		05-14	485 (650)	39 165 (86,360)	5040 (16'6")	15 100 (49'5")	2810 (9'2")



### PAVING PRODUCTS – RECLAIMERS & STABILIZERS

Model	Product Ident. No. Prefix	Years Built	kW Flywheel (Horsepower)	Approximate Operating Weight kg (lb)	General Dimensions (Shipping)		
					Height mm (ft)	Length mm (ft)	Width mm (ft)
SS-250	6DD	85-96	250 (335)	13 300 (29,300)	3220 (10'7")	8780 (28'10")	2900 (9'7")
SS-250B	5GR	96-01	250 (335)	14 340 (31,600)	2600 (8'6")	8560 (28'1")	2900 (9'6")
RR-250	6ED	85-96	250 (335)	17 876 (39,300)	3220 (10'7")	8780 (28'10")	2900 (9'7")
RR-250B	3RR	96-01	250 (335)	19 260 (42,470)	2600 (8'6")	8560 (28'1")	2900 (9'6")
RM-250C			250 (335)	16 780 (37,000)	3220 (10'7")	8780 (28'10")	2921 (9'7")
RM-350	5FK	92-97	321 (430)	21 440 (47,200)	3404 (11'2")	9577 (31'5")	2997 (9'10")
SM-350	1RM	92-97	321 (430)	18 440 (40,600)	3404 (11'2")	9577 (31'5")	2997 (9'10")
RM-350B			373 (500)	24 040 (53,000)	3404 (11'2")	9980 (32'9")	2997 (9'10")
RM500		06-14	403 (540)	28 145 (62,060)	3480 (11'4")	9680 (31'8")	2980 (9'7")

- Paving Products
- Unitized Venturi-Mixers & Unitized Drum-Mixers
- Portable Venturi-Mixers

## Former Models



### PAVING PRODUCTS – UNITIZED VENTURI-MIXERS & UNITIZED DRUM-MIXERS

Model	Drum Dimensions		Gross Volume m <sup>3</sup> (ft <sup>3</sup> )	Performance	
	Diameter mm (ft)	Length m (ft)		Production Range/hr. metric tons (tons)	Air Flow m <sup>3</sup> /min (ft <sup>3</sup> /min)
UVM-500	1829/1524 (6'0"/5'0")	7.9 (26'0")	14.17 (500)	68-109 (75-120)	300-481 (10,600-17,000)
UDM-600	1829 (6'0")	6.7 (22'0")	17.00 (600)	82 (89)	354.25 (12,500)
UDM-900	2134/1829 (7'0"/6'0")	9.1 (30'0")	25.48 (900)	68-227 (75-250)	311-793 (11,000-28,000)
UVM-1000	2134 (7'0")	9.754 (32'0")	28.34 (1000)	82-272 (90-300)	425-1076 (15,000-38,000)
UVM-1400	2286 (7'6")	10.973 (36'0")	39.64 (1400)	100-358 (110-395)	481-1274 (17,000-45,000)
UVM-1700	2591 (8'6")	11.582 (38'0")	48.14 (1700)	122-480 (135-450)	651-1614 (23,000-57,000)



### PAVING PRODUCTS – PORTABLE VENTURI-MIXERS

26

Model	Drum Dimensions		Gross Volume m <sup>3</sup> (ft <sup>3</sup> )	Performance	
	Diameter mm (ft)	Length m (ft)		Production Range/hr. metric tons (tons)	Air Flow m <sup>3</sup> /min (ft <sup>3</sup> /min)
PVM-1100	2134 (7'0")	10.97 (36'0")	31.15 (1100)	82-295 (90-325)	425-1133 (15,000-40,000)
PVM-1500	2286 (7'6")	12.19 (40'0")	42.48 (1500)	100-363 (110-400)	510-1274 (18,000-45,000)
PVM-2000	2591 (8'6")	12.80 (42'0")	56.64 (2000)	122-454 (135-500)	680-1699 (24,000-60,000)
PVM-2500	2896 (9'6")	12.80 (42'0")	70.79 (2500)	136-499 (150-550)	793-2110 (28,000-74,500)
PVM-2900	3048 (10'0")	13.41 (44'0")	82.12 (2900)	168-553 (185-610)	906-2265 (32,000-80,000)
PVM-3300	3200 (10'6")	13.41 (44'0")	93.45 (3300)	181-612 (200-675)	991-2464 (35,000-87,000)

## Former Models

## Paving Products

- Stationary Venturi-Mixers
- SlipForm Pavers



### PAVING PRODUCTS – STATIONARY VENTURI-MIXERS

Model	Drum Dimensions			Performance	
	Diameter mm (ft)	Length m (ft)	Gross Volume m <sup>3</sup> (ft <sup>3</sup> )	Production Range/hr. metric tons (tons)	Air Flow m <sup>3</sup> /min (ft <sup>3</sup> /min)
SVM-1100	2134 (7'0")	10.97 (36'0")	31.15 (1100)	82-295 (90-325)	425-1133 (15,000-40,000)
SVM-1500	2286 (7'6")	12.19 (40'0")	42.48 (1500)	100-363 (110-400)	510-1274 (18,000-45,000)
SVM-2000	2591 (8'6")	12.80 (42'0")	56.64 (2000)	122-454 (135-500)	680-1699 (24,000-60,000)
SVM-2500	2896 (9'6")	12.80 (42'0")	70.79 (2500)	136-499 (150-550)	793-2110 (28,000-74,500)
SVM-2900	3048 (10'0")	13.41 (44'0")	82.12 (2900)	168-553 (185-610)	906-2265 (32,000-80,000)
SVM-3600	3200 (10'6")	14.63 (48'0")	101.94 (3600)	190-623 (210-685)	1020-2565 (36,000-90,000)



### PAVING PRODUCTS – SLIPFORM PAVERS

Model	Product Ident. No. Prefix	Years Built	Flywheel Horsepower	Approx. Operating Weight kg (lb)	Standard Paving Width m (ft)	Shipping Dimensions (Min.)			Remarks
						Length m (ft)	Width m (ft)	Height m (ft)	
SF-175	5ZC	—	142	9072 (20,000)	2.1 (7'0")	6.6 (21'6")	2.4 (8'0")	2.8 (9'4")	
SF-250	6XC	—	208	24 494 (54,000)	3.6 (12'0")	3.0 (10'0")	3.7 (12'0")		
SF-250B	—	—	250	27 216 (60,000)	3.7-7.3 (12'0"-24'0")	1.5 (5'0")	3.66 (12'0")	3.20 (10'6")	
SF-350	—	—	290	40 824 (90,000)	3.6-7.3 (12'0"-24'0")	1.04 (3'5")	3.0 (10'0")	2.9 (9'8")	
SF-450	7GC	73-83	400	43 546* (96,000) 53 525** (118,000)	3.66-7.62 (12'0"-25'0")	9.35 (30'8")	3.05 (10'0")	2.90 (9'6")	
SF-500	8DC	—	400	52 164 (115,000)	7.6 (25'0")	8.9 (29'2½")	3.0 (10'0")	3.0*** (10'2")	
SF-550	5PD	—	400	52 164 (115,000)	5.5-8.5 (18'0"-28'0")	7.0 (23'0")	3.7 (12'0")	2.9 (9'8")	

\*Weight of 7.62 m (25'0") machine.

\*\*Weight of 11.58 m (38'0") machine.

\*\*\*Machine legs and track shipped separately.

- Placer-Spreader-Trimmer
- Belt Placer
- Tube Finisher
- Texturing/Curing
- Trimmer-Reclaimer

## Former Models



### PAVING PRODUCTS – PLACER-SPREADER-TRIMMER, BELT PLACER

Model	Product Ident. No. Prefix	Years Built	Flywheel Horsepower	Approximate Operating Weight kg (lb)	General Dimensions		
					Height m (ft)	Length m (ft)	Width m (ft)
PST-300	8EC	—	250	38 193 <b>(84,200)</b>	2.64 <b>(8'8")</b>	10.57 <b>(34'8")</b>	9.02 <b>(29'7")</b>
BP-100	1EF	—	102	11 340 <b>(22,000)</b>	3.27 <b>(10'9")</b>	2.49 <b>(8'2")</b>	2.49 <b>(8'2")</b>



### PAVING PRODUCTS – TUBE FINISHER, TEXTURING/CURING

Model	Product Ident. No. Prefix	Years Built	Flywheel Horsepower	Approximate Operating Weight kg (lb)	General Dimensions (Shipping)		
					Height mm (ft)	Length mm (ft)	Width mm (ft)
TF-250	6YC	—	52	5897 <b>(13,000)</b>	2489 <b>(8'2")</b>	8484 <b>(27'10")</b>	2438 <b>(8'0")</b>
TC-250	7HC	—	56	5897 <b>(13,000)</b>	2489 <b>(8'2")</b>	8484 <b>(27'10")</b>	2438 <b>(8'0")</b>



### PAVING PRODUCTS – TRIMMER-RECLAIMER

Model	Product Ident. No. Prefix	Years Built	Flywheel Horsepower	Approximate Operating Weight kg (lb)	General Dimensions (Shipping)		
					Height mm (ft)	Length m (ft)	Width mm (ft)
TR-225B	6WC	—	250	21 319 <b>(47,000)</b>	3200 <b>(10'6")</b>	13.9 <b>(45'9.5")</b>	2896 <b>(9'6")</b>
TR-500	8CC	—	375	46 267 <b>(102,000)</b>	3099 <b>(10'2")</b>	8.9 <b>(29'2¾")</b>	3048 <b>(10'0")</b>

## Former Models

## Paving Products

- Asphalt Pavers
- Windrow Elevators



### PAVING PRODUCTS – ASPHALT PAVERS & WINDROW ELEVATORS

Model	Product Ident. No. Prefix	Years Built	Flywheel kW (hp)	Approx. Op. Weight kg (lb)	Drive	Screed Width mm (ft)	Hopper Capacity m <sup>3</sup> (ft <sup>3</sup> )	Maximum Op. Speed m/min (ft/min)
AP-200	2NK	86-01	26 (35)	4080 (9000)	Track	2743 (9'0")	5.4 t (6T)	53.6 (176)
AP-200	6AD	85-91	26 (35)	4080 (9000)	Track	2743 (9'0")	5.4 t (6T)	0-54 (0-177)
AP-650B		-08	97 (130)	13 917 (30,655)		2400 (8'0")	5 t (177T)	67 (220)
AP755	B2T - B3T	06-12	149 (202)	21 600 (47,620)	Track	9100 (29'10")	7.0 (247)	26 (85)
AP-800	1BF	86-89	76 (102)	11 903 (26,350)	Wheel	2438 (8'0")	5.8 (206)	95 (312)
AB-800B	1BF	89-93	76 (102)	11 903 (26,350)	Wheel	2438 (8'0")	5.8 (206)	95 (312)
AP-800C			80 (107)	12 115 (26,700)	Wheel	2438 (8'0")	5.5 (195)	76 (250)
AP-800D			80 (107)	12 115 (26,700)	Wheel	2400 (8'0")	5.5 (195)	76 (250)
AP-900		-06	114 (153)	14 445 (31,850)	Wheel	3000 (10'0")	6.1 (215)	122 (400)
AP-1000B		-05	130 (174)	15 490 (34,150)	Wheel	3000 (10'0")	6.1 (215)	114 (374)
AP-1000D	N/A	05-11	167 (224)	17 851 (39,320)	Wheel	7320 (24'2")	6.1 (215)	91 (300)
AP-1050	1JG	89-96	116 (155)	14 878 (32,800)	Track	3048 (10'0")	6.2 (215)	57 (186)
AP-1050B			130 (174)	16 015 (35,300)	Track	3048 (10'0")	6.1 (215)	61 (200)
AP-1055B			130 (174)	16 556 (36,500)	Track	3048 (10'0")	6.1 (215)	61 (200)
AP-1055D	N/A	05-11	167 (224)	20 330 (44,780)	Track	7320 (24'2")	6.1 (215)	78 (225)
AP-1200	2JD	85-89	108 (145)	13 608 (30,000)	Wheel	3048 (10'0")	6.2 (220)	21.4 (13.3)
WE601B	TEC	85-91	78 (102)	3856 (8500)	N/A	1524 (5'0")	N/A	N/A
BG-200A	N/A	89-91	35 (47)	6750 (14,900)	Wheel	1803 (5'11")	3.26 (116)	56 (180)
BG-210	N/A	90-91	79 (106)	10 192 (22,500)	Wheel	2438 (8'0")	4.76 (170)	84 (275)
BG-210B	N/A	91-01	80 (107)	11 793 (26,000)	Wheel	2438 (8'0")	4.8 (170)	0-21.7 (0-13.5)
BG-220	N/A	84-87	58 (78)	9752 (21,500)	Wheel	2438 (8'0")	3.7 (130)	88 (289)
BG-220B	4ZM	91-94	80 (108)	12 483 (27,525)	Wheel	2438 (8'0")	4.3 (155)	88 (289)

**Paving Products — Asphalt Pavers & Windrow Elevators (cont'd)**

Model	Product Ident. No. Prefix	Years Built	Flywheel kW (hp)	Approx. Op. Weight kg (lb)	Drive	Screed Width mm (ft)	Hopper Capacity m <sup>3</sup> (ft <sup>3</sup> )	Maximum Op. Speed m/min (ft/min)
BG-225	N/A	84-87	58 (78)	11 339 (25,000)	Track	2438 (8'0")	3.7 (130)	58 (188)
BG-225B	N/A		118 (158)	16 400 (36,200)	Track	2438 (8'0")	4.3 (155)	57 (189)
BG-225C			97 (130)	13 917 (30,655)	Track	2400 (8'0")	5 (177)	67 (220)
BG-230			80 (107)	12 111 (26,700)	Wheel	2438 (8'0")	5.5 (195)	76 (250)
BG500E		10-13	106 (142)	15 520 (34,220)	Wheel	2440 (8'0")	6.2 (219)	61 (200)
BG600D		08-13	129 (174)	17 122 (37,747)	Wheel	2440 (8'0")	6.5 (230)	61 (200)
BG-230D			97 (130)	13 307 (29,310)	Wheel	2400 (8'0")	5.5 (195)	76 (250)
BG-240	N/A	85-86	72 (96)	13 154 (29,000)	Wheel	3048 (10'0")	3.7 (130)	81 (265)
BG-240B	7RL	87-99	86 (115)	15 200 (33,500)	Wheel	3048 (10'0")	6.5 (230)	81 (265)
BG-245	N/A	85-87	72 (96)	14 514 (32,000)	Track	3048 (10'0")	5.8 (206)	58 (189)
BG-245B	3XL	87-96	116 (155)	16 080 (35,450)	Track	3048 (10'0")	5.8 (206)	55 (182)
BG-245C	N/A		130 (174)	16 015 (35,300)	Track	3048 (10'0")	6.1 (215)	60.1 (200)
BG-2455C	N/A		130 (174)	16 555 (36,500)	Track	3048 (10'0")	6.1 (215)	61 (200)
BG555E		10-13	106 (142)	16 240 (35,810)	Track	2440 (8'0")	6.2 (219)	61 (200)
BG655D		08-13	129 (174)	18 250 (40,234)	Track	2440 (8'0")	6.5 (230)	61 (200)
BG1055E		11-13	168 (225)	20 076 (44,167)	Track	3000 (10'0")	7.1 (251)	61 (200)
BG-2455D	N/A	05-11	167 (224)	20 330 (44,780)	Track	7320 (24'2")	6.1 (215)	78 (225)
AP600D		08-14	129 (174)	17 122 (37,749)	Wheel	2440 (8'0")	6.5 (230)	61 (200)
AP655D		07-14	129 (174)	18 245 (40,225)	Track	2440 (8'0")	6.5 (230)	61 (200)



## Former Models

### Paving Products

- Asphalt Pavers
- Windrow Elevators

#### Paving Products — Asphalt Pavers & Windrow Elevators (cont'd)

Model	Product Ident. No. Prefix	Years Built	Flywheel kW (hp)	Approx. Op. Weight kg (lb)	Drive	Screed Width mm (ft)	Hopper Capacity m <sup>3</sup> (ft <sup>3</sup> )	Maximum Op. Speed m/min (ft/min)
BG-260	N/A	85-87	106 (142)	14 514 (32,000)	Wheel	3048 (10'0")	5.8 (206)	77 (253)
BG-260B	N/A		116 (155)	14 740 (32,500)	Wheel	3048 (10'0")	5.8 (206)	90 (296)
BG1000E		11-13	168 (225)	18 427 (40,539)	Wheel	3000 (10'0")	7.1 (251)	61 (200)
BG-260D	N/A	05-11	167 (224)	17 851 (39,320)	Wheel	7320 (24'2")	6.1 (215)	91 (300)
BG-265	N/A	85-87	106 (142)	16 782 (37,000)	Track	3048 (10'0")	5.8 (206)	50 (164)
BG-265B	7XK	87-98	145 (195)	18 380 (40,570)	Track	3048 (10'0")	5.8 (206)	50 (164)
BG-270B	N/A		145 (195)	15 510 (34,200)	Wheel	3048 (10'0")	6.5 (230)	90 (296)
BG-610	N/A	85	58 (78)	4394 (9700)	N/A	1524 (5'0")	N/A	N/A
BG-610A	N/A	86-90	58 (78)	4911 (10,840)	N/A	1524 (5'0")	N/A	N/A
BG-650	N/A		80 (107)	7984 (17 600)	N/A	N/A	N/A	N/A
BG-710	N/A		111 (149)	13 380 (29,500)	Wheel	3048 (10'0")	10.0 (80)	98 (320)
BG-730	N/A	87-02	114 (153)	14 061 (31,000)	Wheel	3048 (10'0")	10.0 (80)	0-24.1 (0-15.0)
BG-750	N/A	87-97	116 (155)	17 010 (37,500)	Wheel	4270 (14'0")	10.0 (80)	0-24.1 (0-15.0)
MTP-1260	N/A	86-90	58 (78)	4911 (10,840)	N/A	3048 (10'0")	7.7 (275)	58 (189)
MTP-1265	N/A	88-91	167 (224)	25 368 (56,000)	N/A	3048 (10'0")	11.2 (400)	50 (164)
AP300		06-14	52 (70)	7300 (16,094)	Wheel	1700 (5'7")	3.8 (134)	85 (279)
AP1000E		11-14	168 (225)	18 427 (40,539)	Wheel	3048 (10'0")	7.1 (251)	61 (200)
AP1055E		11-14	168 (225)	20 076 (44,167)	Track	3048 (10'0")	7.1 (251)	61 (200)
AP300D	N/A		55.5 (74.4)	6300 (13,889)	Wheel	1700 (5'7")	3.8 (134)	30 (98)
AP500E	N/A	10-15	106 (142)	12 590 (27,760)	Wheel	2440 (8'0")	6.2 (219)	61 (200)
AP555E	N/A	10-15	106 (142)	13 305 (29,335)	Track	2440 (8'0")	6.2 (219)	61 (200)



PAVING PRODUCTS – SINGLE DRUM VIBRATORY COMPACTORS

Model	Product Ident. No. Prefix	Years Built	Flywheel kW (hp)	Approx. Op. Weight kg (lb)	Drive	Drum Width mm (in)	Centrifugal Force kg (lb)	Maximum Op. Speed km/h (mph)
CS-323	1TM	85-95	57 <b>(77)</b>	4173 <b>(9200)</b>	Wheel/ Drum	1219 <b>(48)</b>	5760 <b>(12,700)</b>	0-10.9 <b>(0-6.8)</b>
CS-323C		04-10	62 <b>(83)</b>	4390 <b>(9680)</b>	Wheel/ Drum	1270 <b>(50)</b>	6804 <b>(15,000)</b>	8.9 <b>(5.5)</b>
CP-323	6JD	85-95	57 <b>(77)</b>	4218 <b>(9300)</b>	Wheel/ Drum	1219 <b>(48)</b>	5760 <b>(12,700)</b>	0-10.9 <b>(0-6.8)</b>
CP-323C		04-10	62 <b>(83)</b>	4745 <b>(10,440)</b>	Wheel/ Drum	1270 <b>(50)</b>	6804 <b>(15,000)</b>	8.9 <b>(5.5)</b>
CS-431	6MD	85-87	52 <b>(70)</b>	6110 <b>(13,480)</b>	Wheel	1680 <b>(66)</b>	7260 <b>(16,000)</b>	21.0 <b>(13.0)</b>
CS-431B	1XF	88-94	76.5 <b>(102)</b>	6312 <b>(13,915)</b>	Wheel	1680 <b>(66)</b>	11 235 <b>(24,746)</b>	12.8 <b>(8.0)</b>
CS-431C	9XL	94-01	78 <b>(105)</b>	6509 <b>(14,349)</b>	Wheel/ Drum	1680 <b>(66)</b>	13 609 <b>(30,000)</b>	12.8 <b>(8.0)</b>
CS-433	6ND	85-87	60 <b>(80)</b>	6720 <b>(14,820)</b>	Wheel/ Drum	1524 <b>(60)</b>	7260 <b>(16,000)</b>	10.0 <b>(6.0)</b>
CP-433	6NP	85-87	60 <b>(80)</b>	6750 <b>(14,870)</b>	Wheel/ Drum	1524 <b>(60)</b>	7260 <b>(16,000)</b>	10.0 <b>(6.0)</b>
CS-433B	4FK	88-94	76.5 <b>(102)</b>	6448 <b>(14,215)</b>	Wheel/ Drum	1680 <b>(66)</b>	11 235 <b>(24,746)</b>	12.8 <b>(8.0)</b>
CS-433C	3TM	94-01	78 <b>(105)</b>	6773 <b>(14,931)</b>	Wheel/ Drum	1680 <b>(66)</b>	13 609 <b>(30,000)</b>	12.8 <b>(8.0)</b>
CS-433E		04-10	75 <b>(100)</b>	6745 <b>(14,875)</b>	Wheel/ Drum	1700 <b>(66)</b>	13 608 <b>(30,000)</b>	11.5 <b>(7.1)</b>
CP-433B	1MG	88-94	76.5 <b>(102)</b>	6668 <b>(15,225)</b>	Wheel/ Drum	1680 <b>(66)</b>	11 235 <b>(24,746)</b>	12.8 <b>(8.0)</b>
CP-433C	2JM	94-01	78 <b>(105)</b>	7075 <b>(15,597)</b>	Wheel/ Drum	1680 <b>(66)</b>	13 609 <b>(30,000)</b>	12.8 <b>(8.0)</b>
CP-433E		04-10	75 <b>(100)</b>	7145 <b>(15,750)</b>	Wheel/ Drum	1700 <b>(66)</b>	13 608 <b>(30,000)</b>	11.5 <b>(7.1)</b>
CS44	N/A		75 <b>(100)</b>	6900 <b>(15,212)</b>	Wheel/ Drum	1676 <b>(5'6")</b>	13 600 <b>(30,000)</b>	12.3 <b>(7.6)</b>
CP44	N/A		75 <b>(100)</b>	7295 <b>(16,083)</b>	Wheel/ Drum	1676 <b>(5'6")</b>	13 600 <b>(30,000)</b>	12.3 <b>(7.6)</b>
CS-531	3WM	93-95	108 <b>(145)</b>	9310 <b>(20,500)</b>	Wheel	2134 <b>(84)</b>	22 680 <b>(50,000)</b>	12.8 <b>(8.0)</b>
CS-531C	5ZN	95-00	108 <b>(145)</b>	9300 <b>(20,450)</b>	Wheel	2134 <b>(84)</b>	24 091 <b>(53,000)</b>	12.8 <b>(8.0)</b>
CS-531D	3AZ 4MZ AGH	98-99 99-04 01-03	108 <b>(145)</b>	9650 <b>(21,230)</b>	Rear Wheel	2130 <b>(84)</b>	27 124 <b>(60,000)</b>	12.7 <b>(7.8)</b>

## Paving Products — Single Drum Vibratory Compactors (cont'd)

Model	Product Ident. No. Prefix	Years Built	Flywheel kW (hp)	Approx. Op. Weight kg (lb)	Drive	Drum Width mm (in)	Centrifugal Force kg (lb)	Maximum Op. Speed km/h (mph)
CS-533	3BL	93-95	108 (145)	10 110 (22,500)	Wheel/ Drum	2134 (84)	22 680 (50,000)	12.8 (8.0)
CS-533C	2WN	95-00	108 (145)	9500 (20,900)	Wheel/ Drum	2134 (84)	24 091 (53,000)	12.8 (8.0)
CS-533D	AET	00-03	108	9960	Drum/	2130	27 124	12.7
CS54	5CZ	00-04	(145)	(21,912)	Rear Wheel	(84)	(60,000)	(7.8)
		07-13	97 (130)	10 840 (23,898)	Wheel/ Drum	2134 (84)	23 860 (52,600)	11.1 (6.9)
CP-533	3ZL	93-95	108 (145)	11 470 (25,250)	Wheel/ Drum	2134 (84)	22 680 (50,000)	12.8 (8.0)
CP-533C	3XN	95-00	108 (145)	10 180 (22,400)	Wheel/ Drum	2134 (84)	24 091 (53,000)	12.8 (8.0)
CP-533D	6AZ	01-04	108	10 240	Drum/	2130	27 124	13.2
CP54	AFC	00-03	(145)	(22,528)	Rear Wheel	(84)	(60,000)	(8.1)
		07-13	97 (130)	11 530 (25,419)	Wheel/ Drum	2134 (84)	23 860 (52,600)	11.1 (6.9)
CS-551	6ZD	85-89	115	10 428	Wheel	2130	18 150	12.1
	8AD		(155)	(22,990)		(84)	(40,000)	(7.5)
CS-553	7AD	85-89	115 (155)	10 782 (23,770)	Wheel/ Drum	2130 (84)	18 150 (40,000)	10.5 (6.5)
CP-553	7BD	85-89	115	12 247	Wheel/	2130	22 680	10.5
			(155)	(27,000)	Drum	(84)	(50,000)	(6.5)
CS-563	8XF	89-95	108 (145)	11 130 (24,500)	Wheel/ Drum	2134 (84)	22 680 (50,000)	12.8 (8.0)
CS-563C	4KN	95-00	108 (145)	11 215 (24,700)	Wheel/ Drum	2134 (84)	24 091 (53,000)	12.8 (8.0)
CS-563D	9MW	98-02	108 (145)	10 875 (23,975)	Wheel/ Drum	2130 (84)	27 216 (60,000)	12.7 (7.8)
CS56		07-13	116	11 414	Wheel/	2134	28 712	11.4
			(156)	(25,164)	Drum	(84)	(63,300)	(7.0)
CP-563	1YJ	89-95	108 (145)	11 580 (25,800)	Wheel/ Drum	2134 (84)	22 680 (50,000)	12.8 (8.0)
CP-563C	5JN	95-00	108 (145)	11 670 (25,700)	Wheel/ Drum	2134 (84)	24 091 (53,000)	12.8 (8.0)
CP-563D	9ZW	98-02	108 (145)	11 275 (24,856)	Wheel/ Drum	2130 (84)	27 216 (60,000)	13.2 (8.1)
CP56		07-13	116	11 361	Wheel/	2134	28 712	11.4
			(156)	(25,047)	Drum	(84)	(63,300)	(7.0)

**Paving Products — Single Drum Vibratory Compactors (cont'd)**

Model	Product Ident. No. Prefix	Years Built	Flywheel kW (hp)	Approx. Op. Weight kg (lb)	Drive	Drum Width mm (in)	Centrifugal Force kg (lb)	Maximum Op. Speed km/h (mph)
CS-573C	6LN	95-00	108 (145)	13 800 (30,360)	Wheel/ Drum	2134 (84)	24 091 (53,000)	12.8 (8.0)
CS-573D	CMK	00-02	108 (145)	12 180 (29,060)	Wheel/ Drum	2130 (84)	27 216 (60,000)	12.7 (7.8)
CS64		07-13	116 (156)	14 238 (31,389)	Wheel/ Drum	2134 (84)	28 712 (63,300)	11.4 (7.0)
CP64		07-13	116 (156)	14 311 (31,550)	Wheel/ Drum	2134 (84)	28 712 (63,300)	11.4 (7.0)
CS-583	8YJ	91-95	108 (145)	15 040 (33,090)	Wheel/ Drum	2134 (84)	22 680 (50,000)	12.8 (8.0)
CS-583C	7MN	95-00	108 (145)	15 230 (33,500)	Wheel/ Drum	2134 (84)	24 091 (53,000)	12.8 (8.0)
CS-583D	2CZ	98-02	108 (145)	14 850 (32,740)	Wheel/ Drum	2130 (84)	31 751 (70,000)	12.7 (7.8)
CS74		07-13	116 (156)	15 455 (34,072)	Wheel/ Drum	2134 (84)	33 840 (74,600)	11.4 (7.0)
CP74		07-13	116 (156)	15 333 (33,804)	Wheel/ Drum	2134 (84)	33 840 (74,600)	11.4 (7.0)
CS-643	7FD	85-87	100 (134)	14 900 (32,855)	Wheel/ Drum	2200 (86)	16 800 (37,044)	15.5 (9.6)
CP-643	7GD	85-87	100 (134)	16 300 (35,942)	Wheel/ Drum	2200 (86)	12 600 (27,783)	15.5 (9.6)
CS76		07-13	130 (174)	16 758 (36,945)	Wheel/ Drum	2134 (84)	33 840 (74,600)	11.4 (7.0)
CP76		07-13	130 (174)	16 896 (37,249)	Wheel/ Drum	2134 (84)	33 840 (74,600)	11.4 (7.0)
CS-653	7HD	85-91	100 (134)	17 100 (37,690)	Wheel/ Drum	2200 (86)	22 230 (48,995)	15.5 (9.6)
CS76 XT		07-13	130 (174)	18 611 (41,030)	Wheel/ Drum	2134 (84)	33 840 (74,600)	11.4 (7.0)
CP-653	7JD	85-91	100 (134)	18 500 (40,774)	Wheel/ Drum	2200 (86)	22 230 (48,995)	15.5 (9.6)
TSF-54	7KD	85-88	26 (35)	2131 (4700)	Towed	1370 (54)	6810 (15,000)	Towed
TSM-54	7LD	86-88	26 (35)	2160 (4760)	Towed	1370 (54)	6810 (15,000)	Towed



**PAVING PRODUCTS – DOUBLE DRUM, COMBI AND PNEUMATIC TIRE COMPACTORS**

Model	Product Ident. No. Prefix	Years Built	Flywheel kW (hp)	Approx. Op. Weight kg (lb)	Drive	Drum Width mm (in)	Centrifugal Force kg (lb)	Maximum Op. Speed km/h (mph)
CB14	DTT	07-12	16.1 <b>(21.6)</b>	1620 <b>(3571)</b>	Hydraulic	800 <b>(31)</b>	1051 <b>(2318)</b>	8.5 <b>(5.0)</b>
CB14 XW	DTT	07-12	16.1 <b>(21.6)</b>	1840 <b>(4057)</b>	Hydraulic	1000 <b>(39)</b>	1164 <b>(2565)</b>	8.5 <b>(5.0)</b>
CB14 Full Flush	DTT	07-12	16.1 <b>(21.6)</b>	1600 <b>(3527)</b>	Hydraulic	900 <b>(35)</b>	1051 <b>(2318)</b>	8.5 <b>(5.0)</b>
CB-214	6FD	85-88	24 <b>(33)</b>	2300 <b>(5070)</b>	Drum (2)	1000 <b>(39.4)</b>	2041 <b>(4500)</b>	10.6 <b>(6.6)</b>
CB-214B	6LF	88-93	24 <b>(33)</b>	2300 <b>(5072)</b>	Drum (2)	990 <b>(39)</b>	2018 <b>(4450)</b>	10.4 <b>(6.5)</b>
CB-214C	6LF	93-00	25 <b>(33)</b>	2320 <b>(5115)</b>	Drum (2)	1000 <b>(39.4)</b>	2592 <b>(5715)</b>	10.5 <b>(6.5)</b>
CB-214D	1TZ	99-03	23.5 <b>(31.5)</b>	2430 <b>(5355)</b>	Hydraulic	1000 <b>(39.4)</b>	2590 <b>(5710)</b>	10.0 <b>(6.2)</b>
CB-214E		-08	24.4 <b>(32.7)</b>	2450 <b>(5400)</b>	Hydraulic	1000 <b>(39)</b>	2751 <b>(6075)</b>	10.0 <b>(6.0)</b>
CB-224	6GD	85-88	24 <b>(33)</b>	2450 <b>(5400)</b>	Drum (2)	1200 <b>(47.2)</b>	2450 <b>(5400)</b>	10.6 <b>(6.6)</b>
CB-224B	6LF	88-93	24 <b>(33)</b>	2450 <b>(5402)</b>	Drum (2)	1199 <b>(47.2)</b>	2449 <b>(5400)</b>	10.4 <b>(6.5)</b>
CB-224C	6LF	93-00	25 <b>(33)</b>	2420 <b>(5335)</b>	Drum (2)	1200 <b>(47.2)</b>	2920 <b>(6570)</b>	10.5 <b>(6.5)</b>
CB-224D	8RZ	99-03	23.5 <b>(31.5)</b>	2610 <b>(5750)</b>	Hydraulic	1200 <b>(47.2)</b>	3039 <b>(6700)</b>	10.0 <b>(6.2)</b>
CB22		08-13	24.6 <b>(33)</b>	2500 <b>(5512)</b>	Hydraulic	1000 <b>(39)</b>	2817 <b>(6210)</b>	10.5 <b>(6.5)</b>
CB24		08-13	24.6 <b>(33)</b>	2700 <b>(5952)</b>	Hydraulic	1200 <b>(47)</b>	3195 <b>(7043)</b>	10.5 <b>(6.5)</b>
CB32		08-13	24.6 <b>(33)</b>	3230 <b>(7121)</b>	Hydraulic	1300 <b>(51)</b>	3195 <b>(7043)</b>	10.5 <b>(6.5)</b>
CC24		08-13	24.6 <b>(33)</b>	2400 <b>(5291)</b>	Hydraulic	1200 <b>(47)</b>	3195 <b>(7043)</b>	10.5 <b>(6.5)</b>
CB-224E		-08	24.4 <b>(32.7)</b>	2630 <b>(5800)</b>	Hydraulic	1200 <b>(47)</b>	3164 <b>(6975)</b>	10.0 <b>(6.0)</b>
CB-225D	9FZ	99-03	23.5 <b>(31.5)</b>	2390 <b>(5270)</b>	Hydraulic	1200 <b>(47.2)</b>	3039 <b>(6700)</b>	10.0 <b>(6.2)</b>
CB-225E		-08	24.4 <b>(32.7)</b>	2300 <b>(5070)</b>	Hydraulic	1200 <b>(47)</b>	3164 <b>(6975)</b>	10.0 <b>(6.0)</b>
CB-314	6HD	85-89	41 <b>(55)</b>	3357 <b>(7400)</b>	Drum	1120 <b>(44)</b>	2770 <b>(6100)</b>	8.0 <b>(5.0)</b>
CB-334D	3JZ 4CZ DCZ	98-03 98-02 02-04	32 <b>(43)</b>	3850 <b>(8490)</b>	Hydraulic	1300 <b>(51)</b>	3263 <b>(7250)</b>	11.0 <b>(7.0)</b>
CB-334E		-08	34.1 <b>(46)</b>	3940 <b>(8688)</b>	Hydraulic	1300 <b>(51)</b>	3378 <b>(7448)</b>	12.5 <b>(8.0)</b>

● Double Drum, Combi and Pneumatic Tire Compactors

Paving Products

Former Models

Paving Products — Double Drum, Combi and Pneumatic Tire Compactors (cont'd)

Model	Product Ident. No. Prefix	Years Built	Flywheel kW (hp)	Approx. Op. Weight kg (lb)	Drive	Drum Width mm (in)	Centrifugal Force kg (lb)	Maximum Op. Speed km/h (mph)
CB-335D	5PZ BBW D4E	98-03 00-03 02-03	32 (43)	3620 (7980)	Hydraulic	1300 (51)	3263 (7250)	11.0 (7.0)
CB34		07-13	34.1 (46)	3940 (8688)	Hydraulic	1300 (51)	3378 (7448)	12.5 (8.0)
CC34		07-13	34.1 (46)	3670 (8091)	Hydraulic	1300 (51)	3378 (7448)	12.5 (8.0)
CB-335E		-08	34.1 (46)	3670 (8092)	Hydraulic	1300 (51)	3378 (7448)	12.5 (8.0)
CB-414	6KD	85-89	52 (70)	5780 (12,750)	Drum	1397 (55)	6350 (14,000)	13.7 (8.5)
CB-424	6LD	85-89	54 (73.5)	6220 (13,710)	Drum (2)	1397 (55)	4485 (9885)	11.0 (6.8)
CB-434	3TF	89-94	60 (80)	6610 (14,540)	Drum (2)	1422 (56)	7620 (16,800)	11.6 (7.2)
CB-434B	6AL	94-95	60 (80)	6577 (14,500)	Drums	1422 (56)	7620 (16,800)	0-11.6 (0-7.2)
CB-434C	4DN	95-03	52 (70)	6485 (14,300)	Hydraulic	1422 (56)	7620 (16,800)	11.6 (7.2)
CB-434D		04-11	62 (83)	7500 (16,535)	Hydraulic	1500 (59)	7960 (17,550)	11.6 (7.0)
CB-434D XW		04-11	62 (83)	7700 (16,975)	Hydraulic	1700 (67)	7960 (17,550)	11.6 (7.0)
CB-514	6YD	85-88	68 (91)	9730 (21,450)	Drum (2)	1730 (68)	9073 (20,000)	11.0 (7.0)
CB-521	6RD	85-87	61 (82)	8800 (19,404)	Wheel	1700 (67)	5300 (11,687)	15.0 (9.3)
CB-522	6SD	85-87	45 (62)	10 100 (22,271)	Drum (2)	1700 (67)	10 350 (22,822)	8.0 (5.0)
CB-523	6TD	85-87	61 (82)	8800 (19,404)	Wheel/ Drum	1700 (67)	5300 (11,687)	13.0 (8.0)
CB-524	6WD	85-87	61 (82)	9500 (20,948)	Drum (2)	1700 (67)	10 350 (22,822)	11.0 (6.8)
CB-534	6EG2YF	87-93	93 (125)	9117 (20,100)	Drum (2)	1700 (67)	11 800 (26,019)	11.2 (7.0)
CB-534B	4JL	93-95	80 (107)	9117 (20,100)	Drums	1676 (66)	12 043 (26,550)	0-11.3 (0-7.0)
CB-534C	5HN	95-02	75 (100)	9195 (20,270)	Drums	1700 (67)	11 975 (26,400)	11.3 (7.0)
CB-534D			97 (130)	10 380 (22,836)	Drums	1700 (67)	11 434 (25,208)	13.0 (8.0)
CB54		09-12	102 (137)	10 804 (23,818)	Hydraulic	1700 (67)	11 300 (24,929)	13.0 (8.0)
CB-534D XW			97 (130)	11 300 (24,860)	Drums	2000 (79)	11 434 (25,208)	13.0 (8.0)
CB54 XW	N/A		102 (137)	11 898 (26,230)	Hydraulic	2000 (6'7")	11 308 (24,929)	13.0 (8.0)

**Paving Products — Double Drum, Combi and Pneumatic Tire Compactors (cont'd)**

Model	Product Ident. No. Prefix	Years Built	Flywheel kW (hp)	Approx. Op. Weight kg (lb)	Drive	Drum Width mm (in)	Centrifugal Force kg (lb)	Maximum Op. Speed km/h (mph)
CB-544	8FM	94-01	60 (80)	10 700 (23,593)	Drums	1700 (67)	8850 (19,510)	8.9 (5.5)
CB-545	2FS	96-01	60 (80)	9410 (20,750)	Wheel/ Drum	1700 (67)	8850 (19,510)	8.9 (5.5)
CB-564D			97 (130)	12 600 (27,783)	Drums	2130 (84)	10 085 (22,234)	13.0 (8.0)
CB-614	7CD	85-93	115 (155)	11 340 (25,000)	Drum (2)	1980 (78)	9525 (21,000)	11.2 (7.0)
CB-634	5CL	94-95	108 (145)		Drums	2134 (84)	12 043 (26,550)	0-9.2 (0-5.7)
CB-634C	3BR	95-01	108 (145)	11 680 (25,750)	Drums	2134 (84)	12 043 (26,550)	12.2 (7.6)
CB64	N/A		102 (137)	12 980 (28,616)	Hydraulic	1680 (5'6")	14 107 (31,100)	13.0 (8.0)
CD54		09-12	74.5 (99.5)	9500 (20,944)	Hydraulic	1700 (67)	8573 (18,900)	9.0 (5.5)
PF-200		85-92	49 (66)	7000 (15,430)	Wheel Pneumatic	1700 (67)	N/A	24.0 (14.9)
PS-110	7MD	85-96	57 (77)	12 500 (27,550)	Wheel Pneumatic	2134 (84)	N/A	38.6 (24.0)
PS-130	7ND	85-96	57 (77)	12 500 (27,550)	Wheel Pneumatic	1700 (67)	N/A	38.6 (24.0)
PS-150	7PD	85-96	57 (77)	15 050 (37,300)	Wheel Pneumatic	1700 (67)	N/A	38.6 (24.0)
PS-150B	3XR	95-04	52 (70)	12 940 (28,535)	Hydraulic	1743 (69)	N/A	25.6 (15.9)
PS150C	N/A		75 (100)	12 940 (28,535)	Hydraulic	1740 (5'8")	NA	25.6 (15.9)
PS-180	7PD	85-96	57 (77)	16 950 (37,000)	Wheel Pneumatic	1727 (68)	N/A	38.6 (24.0)
PS-200B	5JR	95-04	78 (105)	13 010 (28,685)	Hydraulic	1743 (69)	N/A	19.3 (12.0)
PS-300	7TD	85-95	77	21 000	Wheel	1900	N/A	26.5
PF-300	7WD	85-95	(102)	(46,200)	Pneumatic	(75)		(16.4)
PS-300B			74	14 000	Wheel	1920	N/A	19.0
PF-300B			(105)	(30,860)	Pneumatic	(77)		(11.8)
PF-300C			75	21 000	Wheel	1900		13.0
PS-300C			(100)	(46,200)	Pneumatic	(75)		(8.0)
PS-360B			78	8500	Wheel	2275	N/A	18.0
			(105)	(18,740)	Pneumatic	(90)		(11.0)



**SURFACE DRILLS – TRACK DRILLS**

Model	Hole Diameter	Hole Depth	Air Compressor	Rock Drill	Engine	Years Built
MD5050	• Up to 102 mm (4.0 in)	• Up to 31.2 m (102.5 ft)	• 7.08 m <sup>3</sup> /min @ 10.2 bar (250 ft <sup>3</sup> /min @ 150 psi)	• HPR4519 19 kW (25 hp)	• 4HK* 150 kW (203 hp) at 2100 RPM	Up to 2016
MD5050T	• Up to 102 mm (4.0 in)	• Up to 31.2 m (102.5 ft)	• 7.08 m <sup>3</sup> /min @ 10.2 bar (250 ft <sup>3</sup> /min @ 150 psi)	• HPR4519 19 kW (25 hp)	• 4HK* 150 kW (203 hp) at 2100 RPM	Up to 2016
MD5075	• Up to 127 mm (5 in)	• Up to 31.2 m (102.5 ft)	• 9.78 m <sup>3</sup> /min @ 10.2 bar (350 ft <sup>3</sup> /min @ 150 psi)	• HPR4519 19 kW (25 hp)	• Cat C9 ACERT* 224 kW (300 hp) at 1800 RPM	Up to Aug. 2014
MD5090	• Up to 127 mm (5 in)	• Up to 22.1 m (72.5 ft)	• 8.5 m <sup>3</sup> /min @ 10.2 bar (300 ft <sup>3</sup> /min @ 150 psi)	• HPR4519 19 kW (25 hp)	• Cat C9 ACERT* 224 kW (300 hp) at 1800 RPM	Up to 2016
MD5125	• Up to 152 mm (6 in)	• Up to 30 m (98.5 ft)	• 11.3 m <sup>3</sup> /min @ 7 bar (400 ft <sup>3</sup> /min @ 100 psi)	• HPR5128 28 kW (37 hp)	• Tier 3 Cat C11 242 kW (325 hp) at 1800 RPM	Up to Aug. 2014

\*This product meets Tier 3, Stage IIIA, and Japan 2006 (Tier 3) equivalent emission standards.





**SURFACE DRILLS — ROTARY DRILLS**

Model	Hole Diameter	Hole Depth	Air Compressor	Engine	Years Built
MD6240	<ul style="list-style-type: none"> <li>Up to 244 mm (9.625 in)</li> </ul>	<ul style="list-style-type: none"> <li>Depth single-pass (12 m mast) — Up to 12.80 m (42 ft)</li> <li>Depth multi-pass — Up to 55.47 m (182 ft)</li> <li>Depth single-pass (15 m mast) — Up to 15.85 m (52 ft)</li> <li>Depth multi-pass — Up to 31.08 m (102 ft)</li> </ul>	<ul style="list-style-type: none"> <li>48 m<sup>3</sup>/min (1700 ft<sup>3</sup>/min) 6.9 bar (100 psi)</li> <li>32.6 m<sup>3</sup>/min (1150 ft<sup>3</sup>/min) 10.3/24.1 bar (150/350 psi)</li> <li>38.3 m<sup>3</sup>/min (1350 ft<sup>3</sup>/min) 10.3/24.1 bar (150/350 psi)</li> <li>43 m<sup>3</sup>/min (1500 ft<sup>3</sup>/min) 34.5 bar (500 psi)</li> </ul>	<ul style="list-style-type: none"> <li>C27 ACERT*</li> <li>597 kW (800 hp) at 2100 RPM</li> <li>652 kW (875 hp) at 2100 RPM</li> </ul>	Up to 2016
MD6420	<ul style="list-style-type: none"> <li>Up to 311 mm (12.25 in)</li> </ul>	<ul style="list-style-type: none"> <li>Depth single pass (10 m mast) — Up to 10.29 m (33 ft 9 in)</li> <li>Depth multi-pass — Up to 63.4 m (208 ft)</li> <li>Depth single pass (13 m mast) — Up to 13.4 m (44 ft)</li> <li>Depth multi-pass — Up to 74.4 m (244 ft)</li> <li>Depth single pass (16 m mast) — Up to 16.46 m (54 ft)</li> <li>Depth multi-pass — Up to 65.2 m (214 ft)</li> </ul>	<ul style="list-style-type: none"> <li>67.9 m<sup>3</sup>/min (2400 ft<sup>3</sup>/min) 6.9 bar (100 psi)</li> <li>42.5 m<sup>3</sup>/min (1500 ft<sup>3</sup>/min) 10.3/24.1/34.4 bar (150/350/500 psi)</li> <li>67.9 m<sup>3</sup>/min (2400 ft<sup>3</sup>/min) 6.9 bar (100 psi)</li> </ul>	<ul style="list-style-type: none"> <li>C27 ACERT*</li> <li>597 kW (800 hp) at 2100 RPM</li> <li>C27 ACERT*</li> <li>652 kW (875 hp) at 2100 RPM</li> <li>Cummins QST30* 634 and 783 kW (850 and 1050 hp) 783 kW (1050 hp) at 2100 RPM</li> </ul>	Up to 2016
MD6420B	<ul style="list-style-type: none"> <li>Up to 311 mm (12.25 in)</li> </ul>	<ul style="list-style-type: none"> <li>Depth single pass (10 m mast) — Up to 10.29 m (33 ft 9 in)</li> <li>Depth multi-pass — Up to 63.40 m (208 ft)</li> <li>Depth single pass (13 m mast) — Up to 13.4 m (44 ft)</li> <li>Depth multi-pass — Up to 74.4 m (244 ft)</li> <li>Depth single pass (16 m mast) — Up to 16.46 m (54 ft)</li> <li>Depth multi-pass — Up to 65.2 m (214 ft)</li> </ul>	<ul style="list-style-type: none"> <li>56.6 m<sup>3</sup>/min (2000 ft<sup>3</sup>/min) 6.9 bar (100 psi)</li> <li>67.9 m<sup>3</sup>/min (2400 ft<sup>3</sup>/min) 6.9 bar (100 psi)</li> <li>42.5 m<sup>3</sup>/min (1500 ft<sup>3</sup>/min) 34.4 bar (500 psi)</li> </ul>	<ul style="list-style-type: none"> <li>627 kW (850 hp) at 1800 RPM</li> <li>QST30C* (non-cert with cense) 786 kW (1050 hp) at 2100 RPM</li> <li>QST30* 627 kW (850 hp) at 1800 RPM</li> <li>AST30C (non-cert with cense) 783 kW (1050 hp) at 2100 RPM</li> </ul>	Up to 2016
MD6540	<ul style="list-style-type: none"> <li>Up to 381 mm (15 in)</li> </ul>	<ul style="list-style-type: none"> <li>Depth single-pass (16 m mast) — Up to 16.15 m (53 ft)</li> <li>Depth multi-pass — Up to 84.73 m (278 ft)</li> <li>Depth single pass (20 m mast)</li> <li>Depth multi-pass — Up to 65.7 m (215.6 ft)</li> </ul>	<ul style="list-style-type: none"> <li>102 m<sup>3</sup>/min (3600 ft<sup>3</sup>/min) 6.9 bar (100 psi)</li> </ul>	<ul style="list-style-type: none"> <li>MTU Detroit Diesel Series 2000 16V*</li> <li>899 kW (1205 hp) at 1800 RPM</li> </ul>	Up to 2016
MD6750	<ul style="list-style-type: none"> <li>Up to 444 mm (17.5 in)</li> </ul>	<ul style="list-style-type: none"> <li>19.81 m (65 ft)</li> </ul>	<ul style="list-style-type: none"> <li>107.6 m<sup>3</sup>/min (3800 ft<sup>3</sup>/min)</li> </ul>	<ul style="list-style-type: none"> <li>AC Induction Motor</li> <li>Dual Shaft</li> <li>597 kW (800 hp)</li> </ul>	Up to 2014

\*This product meets Tier 2 equivalent emission standards.



## UNDERGROUND MINING — HARD ROCK LOAD-HAUL-DUMPS (LHD'S)

LHD Model	Product Ident. No. Prefix (USA)	Years Built	Flywheel Power kW (hp)	Approx. Shipping Weight kg (lb)	Max. Capacity kg (lb)	Length m (ft)	Height m (ft)	Bucket Width mm (ft)	Breakout Force kg (lb)	Maximum Speeds km/h (mph)	
										Forward	Reverse
R1300	6QW	96-03	123 (165)	20 150 (44,430)	6500 (14,330)	8.66 (28'5")	2.00 (6'7")	2000 (6'7")	12 020 (26,500)	26.1 (16.2)	23.8 (14.6)
R1300G	LJB	03-13	123 (165)	20 950 (46,187)	6800 (14,991)	8.71 (28'7")	2.12 (6'11")	2200 (7'3")	12 020 (26,500)	24.0 (14.9)	23.0 (14.3)
R1300GII	RSL	06-08	136 (182)	20 875 (46,021)	6800 (14,991)	8.71 (28'7")	2.12 (6'11")	2200 (7'3")	15 350 (33,841)	26.1 (16.2)	25.9 (16.1)
R1500	BAY	86-00	178 (239)	25 100 (55,360)	9000 (19,850)	9.19 (30'2")	2.30 (7'7")	2480 (8'2")	18 460 (40,700)	30.4 (18.9)	33.0 (20.5)
R1600	9EW	97-03	201 (270)	29 800 (65,710)	10 200 (22,490)	9.71 (31'10")	2.40 (7'10")	2600 (8'6")	19 280 (42,510)	30.6 (19.0)	34.0 (21.1)
R1600	9XP	01-03	201 (270)	29 800 (65,710)	10 200 (22,490)	9.71 (31'10")	2.40 (7'10")	2600 (8'6")	19 280 (42,510)	30.6 (19.0)	34.0 (21.1)
R1600G	9PP	03-08	201 (270)	29 800 (65,700)	10 200 (22,490)	9.71 (31'10")	2.40 (7'10")	2600 (8'6")	19 000 (41,888)	22.9 (14.2)	23.8 (14.8)
R1600G	9YZ	07-13	201 (270)	29 800 (65,700)	10 200 (22,490)	9.71 (31'10")	2.40 (7'10")	2600 (8'6")	19 000 (41,888)	22.9 (14.2)	23.8 (14.8)
R1700 Series II	4LZ	94-00	231 (310)	34 500 (76,100)	12 000 (26,460)	10.42 (34'2")	2.53 (8'4")	2820 (9'3")	23 430 (51,660)	29.3 (18.2)	33.3 (20.7)
R1700G	8XZ	99-06	262/241 (351/323)	38 500 (84,878)	14 000* (30,865)*	10.59 (34'9")	2.56 (8'5")	2894 (9'6")	20 100 (44,313)	24.1 (15.0)	25.3 (15.7)
R2800	BBR	88-98	231 (310)	42 660 (94,070)	16 200 (35,720)	10.70 (35'1")	2.68 (8'10")	3000 (9'10")	26 540 (68,530)	29.3 (18.2)	33.3 (20.7)
R2900	5TW	95-03	269 (361)	48 850 (107,710)	17 200 (37,920)	10.97 (36'0")	2.89 (9'6")	3100 (10'2")	28 600 (63,060)	26.7 (16.6)	32.5 (20.2)
R2900G	GLK	02-05	306 (410)	50 100 (110,451)	17 200 (37,920)	11.3 (37'1")	2.89 (9'6")	3176 (10'5")	27 346 (60,298)	25.3 (15.7)	26.4 (16.4)
R2900G XTRA	GLK	02-05	306 (410)	53 100 (117,065)	20 000* (44,092)*	11.3 (37'1")	2.89 (9'6")	3400 (11'2")	27 346 (60,298)	25.3 (15.7)	26.4 (16.4)
R2900G XTRA	JLK	05-13	333 (447)	55 575 (122,522)	20 000* (44,092)*	11.3 (37'1")	2.99 (9'10")	3500 (11'6")	27 346 (60,298)	25.3 (15.7)	26.4 (16.4)

\*Capacity is for tramming only. Truck loading capacity is lower.

## Former Models

## Underground Mining — Hard Rock Trucks

- Articulated Trucks
- Rigid Frame Trucks



## UNDERGROUND MINING — HARD ROCK TRUCKS

### Articulated Trucks

Truck Model	Product Ident. No. Prefix (USA)	Years Built	Flywheel Power kW (hp)	Approx. Shipping Weight kg (lb)	Max. Capacity kg (lb)	Length m (ft)	Height m (ft)	Body Width mm (ft)	Maximum Speeds km/h (mph)	
									Forward	Reverse
AD30	CXR	02-05	304 (408)	28 870 (63,647)	30 000 (66,139)	10.2 (33'4")	2.60 (8'6")	2690* (8'10")*	40.8 (25.4)	7.8 (4.8)
AD40	1YZ	94-02	380 (510)	38 100 (84,000)	40 000 (88,200)	10.7 (35'0")	2.70 (8'10")	3000 (9'10")	48.1 (29.9)	10.6 (6.6)
AD40 Series II	N/A	N/A	380 (510)	41 800 (92,170)	40 000 (88,200)	11.3 (37'0")	2.89 (9'6")	3200 (10'5")	41.7 (25.9)	9.6 (6.0)
AD45	BKZ	01-05	439 (589)	39 359 (86,772)	45 000 (99,208)	11.2 (36'9")	2.82 (9'5")	3000* (9'10")*	52.0 (32.3)	10.7 (6.6)
AD55	ANW	01-03	485 (650)	47 000 (103,617)	55 000 (121,254)	11.6 (37'11")	3.20 (10'6")	3346* (11'0")*	42.3 (26.3)	9.0 (5.6)
AD55B	JNW	07-13	600 (805)	50 000 (110,231)	55 000 (121,254)	12.0 (39'0")	3.4 (11'2")	3346* (11'0")*	41.5 (25.8)	8.7 (5.4)

### Rigid Frame Trucks

69D Dump	9XS	00-04	380 (510)	30 100 (66,371)	38 000 (83,790)	8.1 (26'8")	3.4 (11'4")	3665 (12'0")	76.6 (47.6)	13.5 (8.4)
69D Ejector	9XS	00-04	380 (510)	34 700 (78,514)	36 200 (79,821)	7.8 (25'8")	3.4 (11'4")	3665 (12'0")	75.2 (46.7)	13.5 (8.4)

\*Overall width less body.



## UNDERGROUND MINING – ROOM &amp; PILLAR – CONTINUOUS MINERS

Model	Prefix	Exit Year	Bucyrus Model	Total Power kW (hp)	Cutter Head Power kW (hp)	Loading Capacity tonnes/min (Tons/min)	Recommended Mining Range mm (in)	Machine Weight tonnes (lb)
CM235	GEG	2014	25C	701 (940)	2 × 205 (2 × 275)	14-29 (15-32)	914-3251 (36-128)	61.2 (135,000)
CM330	GEY	2014	30M2	698 (930)	2 × 104 (2 × 280)	24 (26.5)	up to 3170 (up to 125)	61.7 (136,000)
CM845	GE6	2015	30MB	674 (904)	2 × 173 (2 × 232)	31.5 (35)	2800-3900 (110-153)	92.0 (202,800)



## UNDERGROUND MINING – ROOM &amp; PILLAR – LHDs

Model	Prefix	Exit Year	Bucyrus Model	Bucket Payload kg (lb)	Fork Payload kg (lb)	Engine	Engine Power kW (hp)	Machine Weight kg (lb)
CL106		2014	N/A					
CL110	LH4	2014	N/A	8000 (17,636)	10 000 (22,046)	Cat C7 ACERT	171.5 (230)	21 500 (47,400)
CL115	LH6	2014	N/A					
CL215B		2014	MH15					

26



## UNDERGROUND MINING – ROOM &amp; PILLAR – SCOOPS

Model	Prefix	Exit Year	Bucyrus Model	Lift Capacity tonnes (Tons)	Engine	Engine Power kW (hp)	Tram Speed km/h (mph)	Weight with Battery kg (lb)
SU482 DN (diesel non permissible)	LAW	2014	482D	6.8 (7.5)	Duetz BF4L 2011	58 (78)	16.9 (10.5)	
SU482	LAP	2014	488XL	6.4 (7.0)	Battery		8.0 (5.0)	
SU488 DM (dual motor)	LA4	2014	488-6 DM	14.5 (16.0)	Battery		8.0 (5.0)	26 853 (59,200)
SU488 D XP (explosion proof)		2014	488D XP	14.5 (16.0)	Duetz	112 (150)	17.9 (11.1)	
SU488 LHD	LA6	2014	488D LHD XP	10.9 (12.0)	Duetz 1013 FC	112 (150)	17.9 (11.1)	
SU488 LHD N	LA7	2014	488D LHD	10.9 (12.0)	Duetz 1013 FC	112 (150)	17.9 (11.1)	
SU488 DM AC (alternating current)	LA4	2014	488-6 DM	14.5 (16.0)	Battery		8.0 (5.0)	26 853 (59,200)
SU636		2014						

## Former Models

### Underground Mining – Room & Pillar

- Haulage (Face Haulers, Continuous Haulage)
- Feeder Breakers



### UNDERGROUND MINING – ROOM & PILLAR – HAULAGE (FACE HAULERS, CONTINUOUS HAULAGE)

Model	Prefix	Exit Year	Bucyrus Model	Payload Capacity tonnes (Tons)	Machine Weight – empty kg (lb)	Minimum Operating Height mm (in)	Engine Type	Engine Power kW (hp)
FH110	FHM	2014	810C Un-a-trac	9.0 (10.0)	31 524 – with battery (69,500)	1066 (42)		
FH125 D	FHX	2014	FBR 15 Ram Car	20.0 (22.0)	25 000 – full tanks (55,115)	1900 (74.8)	Cat 3126	172 (230)
FH336 (Continuous Haulage)	FHZ	2014	36 CHH	27.0 (30.0)	27 216 (60,000)	965 (38)		



### UNDERGROUND MINING – ROOM & PILLAR – FEEDER BREAKERS

Model	Prefix	Exit Year	Bucyrus Model	Capacity Throughput tonnes/hr (Tons/hr)	Minimum Operating Height mm (in)	Operating Weight kg (lb)	Total Power kW (hp)
FB75	FBP	2014	7MFBH-48A LOW	717 (790)	1270 (50)	31 751 (70,000)	151 (200)
			GH-MFBHM-48CDL	1089 (1200)	1219 (48)	27 215 (60,000)	151 (200)
FB75 P (permissible)	FBP	2014					
FB85	FBE	2014	7FB-56AL	860 (950)	836 (34)	31 750 (70,000)	150 (200)
FB85 P (permissible)	FBE	2014	7FB-56AL	860 (950)	837 (34)	31 750 (70,000)	151 (200)
FB110 P (permissible)	FBL	2014	7FB-48A	1146 (1263)	1219 (48)	31 750 (70,000)	151 (200)

- Roof Bolters
- Roof Support Carriers



**UNDERGROUND MINING — ROOM & PILLAR — ROOF BOLTERS**

Model	Prefix	Exit Year	Bucyrus Model	Drilling Torque N·m (lbf·ft)	Minimum Tram Height mm (ft)	Maximum ATRS Reach mm (ft)
RB120	RM9	2014	LRB-15AR	380 <b>(280)</b>	813 <b>(2'8")</b>	1930 <b>(6'4")</b>
RB230	RP9	2014	RB2-88A	420 <b>(310)</b>	1181 <b>(3'10.5")</b>	3048 <b>(10'0")</b>



**UNDERGROUND MINING — ROOM & PILLAR — ROOF SUPPORT CARRIERS**

Model	Prefix	Exit Year	Bucyrus Model	Lift Capacity – No Ballast tonnes (Tons)	Machine Weight kg (lb)	Tram Speed Level Unloaded km/h (mph)	Engine Type	Engine Power kW (hp)
SH650 VFD	RS6	2014	VT650	45.0 <b>(50.0)</b>	46 040 — with battery <b>(101,500)</b>	6.6 <b>(4.1)</b>	Battery	N/A
SH650 D	RS5	2014	VT650D	45.0 <b>(50.0)</b>	45 359 kg <b>(100,000)</b>	13.7 <b>(8.5)</b>	Cummins C8.3	179 <b>(240)</b>
SH660 D	JE3	2014	FBL-55	55.0 <b>(60.625)</b>	48 000 — tanks full <b>(105,821)</b>	19.5 <b>(12.1)</b>	Cat C7 ACERT	171.5 <b>(230)</b>



# LAND CLEARING

## CONTENTS

Variables Affecting Clearing Operations. . . . .	27-1
Job Surveys . . . . .	27-2
Clearing Methods and Equipment . . . . .	27-2
Equipment Selection Table . . . . .	27-3
Production Estimating:	
General. . . . .	27-5
Cutting. . . . .	27-6
Piling . . . . .	27-7
Work Tools. . . . .	27-9

Land clearing must be treated more as an art than a science because production rates and methods vary greatly from one area to another. This section deals with the many variables in clearing and includes methods, equipment and procedures to determine productivity rates.

## VARIABLES AFFECTING CLEARING OPERATIONS

*Vegetative Growth* — Factors affecting production and therefore cost, include the number of trees, size of trees, wood density, root systems, vines and undergrowth. These factors can be estimated by a “tree-count” as discussed under “Job Survey.”

*End Use of Land* — Since different end uses require different degrees of clearing (i.e. highways, dams, tree crops, row crops, etc.), this is one of the most important factors to consider in choosing the proper clearing method and equipment.

*Soil Conditions or Bearing Capacity* — Factors affecting clearing operations include topsoil depth, soil type, moisture content, and the presence of rocks and stones.

*Topography* — Grade and terrain factors such as steep slopes, ditches, swampy areas, boulders and even ant hills greatly affect the normal operation of some equipment.

*Rainfall and Climate* — Usually all phases of land clearing from cutting to burning are concerned to some degree with temperature changes and the amount of rainfall during the clearing operation.

*Job Specifications* — Specifications dictate the degree of clearing to be done, area size, completion dates, method of debris disposal, soil conservation and other factors which affect method and equipment selection.



**JOB SURVEYS**

Knowledge of rainfall and climate, end use of the land, and job specifications can be obtained from records, surveys, engineering studies, and written specifications. You should personally review the land to be cleared to gain other necessary and valuable information.

The survey should include a study of general topography and soil conditions. Note such problem factors as hills, rocks, or swamps which would significantly affect production or which would require special treatment.

Cruise the area to be cleared and determine the acreage of each vegetative type (i.e. upland woods, low timberlands, swamps). Make at least three tree counts at random for each vegetation type. To conduct these counts, randomly locate two points 100 meters (328 feet) apart. Count and measure vegetative growth along a straight line between these points for a width of about 5 meters (16 feet) on both sides. This gives the population of 1/10 hectare (1/4 acre).

1. Density of vegetation less than 30 cm (12 in) diameter
  - Dense — 1480 trees/hectare or more  
(600 trees/acre)
  - Medium — 990-1480 trees/hectare  
(400-600 trees/acre)
  - Light — less than 990 trees/hectare  
(400 trees/acre)
2. Presence of hardwoods expressed in percent
3. Presence of heavy vines
4. Average number of trees per hectare (2.47 acres) in each of the following ground level diameter size ranges:
  - Less than 30 cm (1 ft)
  - 31 cm-60 cm (1-2 ft)
  - 61 cm-90 cm (2-3 ft)
  - 91 cm-120 cm (3-4 ft)
  - 121 cm-180 cm (4-6 ft)
5. Sum of diameter of all trees per hectare (2.47 acres) above 180 cm (6 ft) in diameter at ground level.

**CLEARING METHODS AND EQUIPMENT**

*Methods for Initial Felling* — There are several methods indicating the degree of clearing for initial felling and several types of equipment for use with each method. Equipment use in different size vegetation and different size areas is summarized in the table on the next page. This information should serve only as a rough guideline in selecting equipment. The economical land area for each type of equipment will vary with the capital cost of equipment and moving cost. It is also affected by whether there are alternate uses for equipment such as using tractors for other construction work or tillage.

*Land Clearing Machines* — Job size, severity of job such as tree size, and time limit to complete will influence machine selection. Some machines, such as purpose built forestry equipment and track-type tractors are more suited for this type of work than others, but imagination and resourcefulness can allow the use of other types of machines in specific applications. For example, loaders are used more today in raking and piling operations than ever before.

*Operator Protection and Machine Guarding* — Daily production has been estimated to increase 20% when cab guards are used. Cabs designed specifically for forestry and clearing applications are available on purpose built Cat® forestry equipment. Auxiliary equipment manufacturers such as Rome™ offer after market guard packages for non-purpose built units.

Locally designed and manufactured guarding for non-purpose built equipment is required. The radiator, engine, and underside of the tractor must be well protected. Perforated hoods, screens, crankcase guards and hydraulic cylinder guards are generally recommended.

Generally speaking lower cost clearing can be done with purpose built forestry equipment and larger tractors if the amount of clearing involved is sufficient to merit the initial investment of purpose built or if the amount of clearing involved is sufficient to merit the initial investment in the bigger machine. In applications where track-type tractors are used, power shift transmissions should be standard due to the frequent direction changes. The direct drive transmission tractor is recommended when the tractor is used principally in constant drawbar work such as chaining or pulling a disc harrow. In most applications, a winch should also be considered on one of every three tractors in a fleet.

## EQUIPMENT SELECTION TABLE

	UPROOTING	CUTTING AT OR ABOVE GROUND LEVEL	KNOCKING TO THE GROUND	INCORPORATING INTO THE SOIL
<b>LIGHT CLEARING — Vegetation up to 5 cm (2 in) diameter</b>				
Small areas 4 hectares (10 acres)	Bulldozer blade; forestry machine road builder arrangement	Wheel-mounted circular saws	Bulldozer blade; forestry machine road builder arrangement	Moldboard plows, disc plows, disc harrows
Medium areas 40 hectares (100 acres)	Bulldozer blade; forestry machine road builder arrangement	Heavy duty sickle mowers [up to 3.7 cm (1½ in) diameter] tractor-mounted circular saws, suspended rotary mowers; site prep tractor with brush cutter or mulcher attachment	Bulldozer blade, rotary mowers; flail-type rotary cutters; rolling brush cutters; forestry machine road builder arrangement; site prep tractor with brush cutter or mulcher attachment	Moldboard plows; disc plows, disc harrows; site prep tractor with mulcher attachment
Large areas 400 hectares (1000 acres)	Bulldozer blade, root rake, grubber, root plow, anchor chain drawn between two crawler tractors; rails	Site prep tractor with brush cutter or mulcher attachment	Rolling brush cutter; flail-type cutter; anchor chain drawn between two crawler tractors; rails; site prep tractor with brush cutter or mulcher attachment	Undercutter with disc; moldboard plows; disc plows; disc harrows; site prep tractor with mulcher attachment
<b>INTERMEDIATE CLEARING — Vegetation 5 to 20 cm (2 to 8 in) diameter</b>				
Small areas 4 hectares (10 acres)	Bulldozer blade; forest machine road builder arrangement	Wheel-mounted circular saws	Bulldozer blade; forestry machine road builder arrangement	Heavy-duty disc plow; disc harrow
Medium areas 40 hectares (100 acres)	Bulldozer blade; forest machine road builder arrangement	Tractor-mounted circular saws, single scissor type tree shears; site prep tractor with brush cutter or mulcher attachment; wheel/track feller buncher with high speed saw head; forest machine with directional felling head	Bulldozer blade, rolling brush cutter [up to 12 cm (5 in) diameter], rotary mower [up to 10 cm (4 in) diameter]; forestry machine road builder arrangement; Site prep tractor with brush cutter or mulcher attachment	Heavy-duty disc plow; disc harrow; site prep tractor with mulcher attachment
Large areas 400 hectares (1000 acres)	Shearing blade, angling (tilted) bulldozer blade, rakes, anchor chain drawn between two crawler tractors, root plow	Shearing blade (angling or V-type); site prep tractor with brush cutter or mulcher attachment; wheel/track feller buncher with high speed saw head; forest machine with directional felling head	Bulldozer blade, flail-type rotary cutter, anchor chain; site prep tractor with brush cutter or mulcher attachment	Bulldozer blade with duty harrow; site prep tractor with mulcher attachment

**NOTE:** The most economical size area for each type of equipment will vary with the relative cost of capital equipment versus labor. It is also affected by whether there are alternate uses for equipment such as using tractors for tillage.

**EQUIPMENT SELECTION TABLE**

	UPROOTING	CUTTING AT OR ABOVE GROUND LEVEL	KNOCKING TO THE GROUND	INCORPORATING INTO THE SOIL
<b>LARGE CLEARING — Vegetation 20 cm (8 in) diameter or larger</b>				
Small areas 4 hectares (10 acres)	Bulldozer blade; forest machine road builder arrangement; Forest machine with directional felling head	—	Bulldozer blade; forest machine road builder arrangement; forest machine with directional felling head	—
Medium areas 40 hectares (100 acres)	Shearing blade, angling (tilted), knockdown beam, rakes, tree stumper; forest machine road builder arrangement; forest machine with directional felling head	Shearing blade (angling or V-type), tree shear [up to 70 cm (26 in) softwood; 35 cm (14 in) hardwood], shearing blade — power saw combination; wheel/ track feller buncher with high speed saw head; forest machine with directional felling head	Bulldozer blade; forest machine road builder arrangement; forest machine with directional felling head	—
Large areas 400 hectares (1000 acres)	Shearing blade, angling (tilted), tree pusher, rakes, tree stumper, anchor chain with ball drawn between two crawler tractors; forest machine with directional felling head	Shearing blade (angling or V-type), shearing blade — power saw combination; wheel/track feller buncher with high speed saw head; forest machine with directional felling head	Anchor chain with ball drawn between two crawler tractors. [Use dozer blade for trees over 18 cm (7 in).]; forest machine road builder arrangement; forest machine with directional felling head	—

**NOTE:** The most economical size area for each type of equipment will vary with the relative cost of capital equipment versus labor. It is also affected by whether there are alternate uses for equipment such as using tractors for tillage.

## PRODUCTION ESTIMATING

### GENERAL — CONSTANT SPEED OPERATIONS

Production is the hourly clearing rate usually expressed in hectares or acres.

For many land clearing operations, production is calculated by multiplying the tractor speed by the width of cut and converting to hectares or acres per hour.

#### Metric system:

The base formula is:

$$\frac{\text{Width of cut (meters)} \times \text{speed (km/h)}}{10} = \text{hectares/h}$$

When an efficiency of 82.5% is used, the formula becomes:

$$\frac{\text{Width of cut (m)} \times \text{speed (km/h)} \times 0.825}{10} = \text{hectares/h}$$

#### English measure:

$$\frac{\text{Width of cut (ft)} \times \text{speed (mph)}}{43,560 (\text{ft}^2)} = \text{acres/hr}$$

The American Society of Agricultural Engineers formula for estimating hourly production of a constant speed operation is based on 82.5% efficiency. With this efficiency, the formula becomes:

$$\frac{\text{Width of cut (ft)} \times \text{speed (mph)} \times 0.825}{43,560 (\text{ft}^2)} = \text{acres/hr}$$

Width of cut is the effective working width of the equipment and may not be the same as its rated width. Working width should be measured on the job but can be estimated when necessary.

The actual machine speed can be determined by measuring the amount of time to travel a given distance. When using the metric system, the time to travel 16.7 meters or a multiple thereof, can be converted into kilometers per hour.

$$\frac{1.0}{\text{(Time in min. to travel 16.7 meters)}} = \text{speed (kmh)}$$

Since 88 ft/min. equals one mph, the lapsed time to travel 88 ft, or a multiple of 88 ft, can easily be converted into miles per hour.

$$\frac{1.0}{\text{(Time in min. to travel 88 ft)}} = \text{speed (mph)}$$

The following nomographs in both the Metric and English systems convert speed and width of cut directly into acres or hectares per hour at 82.5% efficiency without the need for calculations.

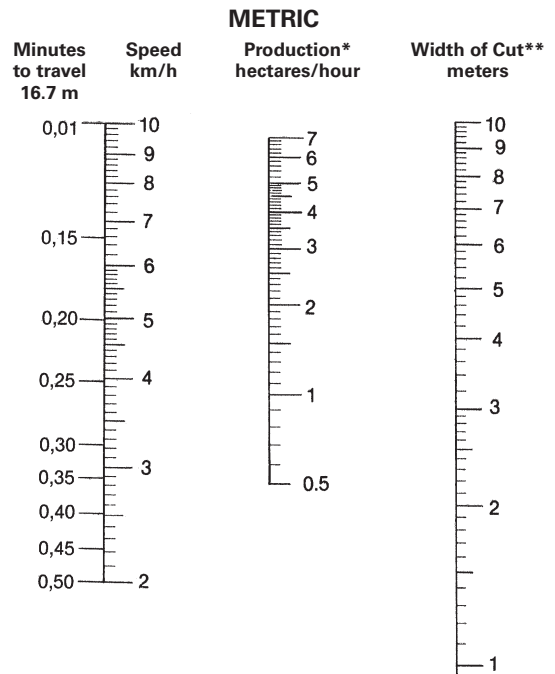

\*Based on 82.5% efficiency.

\*\*When width of cut exceeds 10 meters, use a multiple of the width of cut and increase production proportionately.

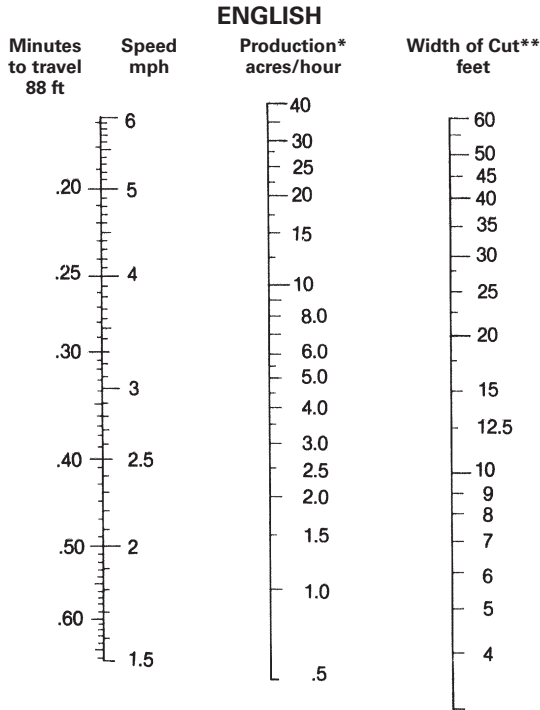

\*Based on 82.5% efficiency.

\*\*When width of cut exceeds 60 feet, use a multiple of the width of cut and increase production proportionately.

**CUTTING PRODUCTION ESTIMATING**

Most land clearing operations such as bulldozing, cutting, grubbing, raking and piling are not performed at constant speed. Because off-the-job production is difficult to estimate for these operations, Rome Industries has developed formulas for estimating cutting and piling time. These formulas take into consideration variable prime mover speeds through a factor, “B”, the base time for each tractor to cover one hectare (2.47 acres) of light material.

To estimate **tractor cutting time per hectare** (2.47 acres) on a specific land clearing job, apply the factors shown in the following table, together with data obtained from the job survey, in the formula:

$$T = X [A(B)+M_1N_1+M_2N_2+M_3N_3+M_4N_4+DF]$$

where

- T = Time per hectare (2.47 acres) in minutes
- X = Hardwood or density factor affecting total time

- A = Density or vine presence factor affecting base time
- B = Base time for each tractor per hectare (2.47 acres)
- M = Minutes per tree in each diameter range
- N = Number of trees per hectare (2.47 acres) in each diameter range obtained from field survey
- D = Sum of diameter in 30 cm (1 ft) increments of all trees per hectare (2.47 acres) above 180 cm (6 ft) in diameter at ground level obtained from field survey
- F = Minutes per 30 cm (1 ft) of diameter for trees above 180 cm (6 ft) in diameter.

Hardwoods affect over-all or total time as follows:

- 75-100% hardwoods: Add 30% to total time (X = 1.3)
- 25-75% hardwoods: No change (X = 1.0)
- 0-25% hardwoods: Subtract 30% from total time (X = 0.7)

**Production Factors for Felling with Rome K/G Blades**

Tractor	Base Minutes per hectare (2.47 acres) "B"	Diameter Range				Dia. above 180 cm per 30 cm (6' per foot) "F"
		30-60 cm (1-2 ft) "M <sub>1</sub> "	60-90 cm (2-3 ft) "M <sub>2</sub> "	90-120 cm (3-4 ft) "M <sub>3</sub> "	120-180 cm (4-6 ft) "M <sub>4</sub> "	
165 hp	85	0.7	3.4	6.8	—	—
230 hp	58	0.5	1.7	3.3	10.2	3.3
305 hp	45	0.2	1.3	2.2	6.0	1.8
405 hp	39	0.1	0.4	1.3	3.0	1.0

**Explanation of columns in table:**

*Tractor* — Based on current model tractors (power shift when applicable) working on reasonably level terrain (below 10% grade) with good footing, no stones, average mixture of soft and hard woods. Tractor is in proper operating condition, blade is sharp, and properly adjusted.

*Base Minutes* — The base figures represent the number of minutes required for each tractor to cover a hectare (2.47 acres) of light material where no trees require splitting or other individual treatment. Time required is affected by the density of material less than 30 cm (1 ft) in diameter and the presence of vines.

- a. dense — 1480 trees/hectare (600 or more trees/acre): Add 100% to base time (A = 2.0)
- b. medium — 990-1480 trees/hectare (400-600 trees/acre): No change (A = 1.0)
- c. light — less than 990 trees/hectare (400 trees/acre): Subtract 30% from total time (A = 0.7)

Presence of heavy vines: Add 100% to base time (A=2.0). *Very* heavy vines add 300% to base time. (A=3.0)

*Dia. Range* — M<sub>1</sub> represents minutes required to cut trees from 31-60 cm (1-2 ft) in diameter at ground level.

M<sub>2</sub> same for trees 61-90 cm (2-3 ft) diameter.

M<sub>3</sub> same for trees 91-120 cm (3-4 ft) diameter.

M<sub>4</sub> same for trees 121-180 cm (4-6 ft) diameter.

*For Dia. above 180 cm (6 ft)* — The figures in this column represent size the number of minutes required per 30 cm (1 ft) of diameter for each tractor to cut trees above 180 cm (6 ft) in diameter. Thus, to fell a 240 cm (8 ft) diameter tree would require 8 × 1.8 or approximately 14.4 minutes with a D8T.

Example problem:

Calculate the felling production of a D8T with K/G Blade in these conditions: reasonably level terrain, firm ground, well drained, 85% hardwoods with heavy vines and the following average tree count per hectare (2.47 acre):

Diameter Range	Less than 30 cm (1 ft) "B"	31-60 cm (1-2 ft) "N <sub>1</sub> "	61-90 cm (2-3 ft) "N <sub>2</sub> "	91-120 cm (3-4 ft) "N <sub>3</sub> "	121-180 cm (4-6 ft) "N <sub>4</sub> "	Sum Dia's Above 180 cm (6 ft) "D"
Number of Trees	1100	35	6	6	4	488 cm (16 ft)

**Solution:**

$$\begin{aligned}
 T &= X [A(B)+M_1N_1+M_2N_2+M_3N_3+M_4N_4+DF] \\
 T &= 1.3 [2.0 (45)+0.2 (35)+1.3 (6)+2.2 (6)+6 (4)+16 (1.8)] \\
 &= 1.3 (90+7+7.8+13.2+24+28.8) \\
 &= 1.3 (170.8) \\
 &= 222 \text{ minutes/hectare (90 min/acre)}
 \end{aligned}$$



Where the job requires grubbing trees and stumps greater than 30 cm (1 ft) in diameter at the same time the trees are sheared, use the same basic procedure as defined above including the variables for the presence of hardwoods. After time per hectare (acre) in minutes has been determined, increase the over-all or total time by 25%.

Where the job requires re-entering the area (after all trees have been sheared) to remove stumps with a tilted shearing blade or stump, increase the total time by 50%.

**PILING PRODUCTION ESTIMATING**

A procedure has also been developed for estimating piling production for a tractor equipped with a K/G blade or rake.

To estimate tractor hours per hectare (acre) on a specific land clearing job, apply the factors shown in the following table with data obtained from the job survey, in the formula:

$$T = B+M_1N_1+M_2N_2+M_3N_3+M_4N_4+DF$$

where

T = Time per hectare (2.47 acre) in minutes.

B = Base time for each tractor per hectare (2.47 acre).

M = Minutes per tree in each diameter range.

N = Number of trees per hectare (2.47 acre) in each diameter range obtained from field cruise.

D = Sum of diameter in 30 cm (1 ft) increments of all trees per hectare (2.47 acre) above 180 cm (6 ft) in diameter at ground level obtained from field cruise.

F = Minutes per 30 cm (1 ft) of diameter for trees above 180 cm (6 ft) in diameter.

**Production Factors for Piling in Windrows\***

Tractor	Base Minutes per hectare (2.47 acres) "B"	Diameter Range				Dia. above 180 cm per 30 cm (6' per foot) "F"
		30-60 cm (1-2 ft) "M <sub>1</sub> "	60-90 cm (2-3 ft) "M <sub>2</sub> "	90-120 cm (3-4 ft) "M <sub>3</sub> "	120-180 cm (4-6 ft) "M <sub>4</sub> "	
165 hp	157	0.5	1.0	4.2	—	—
230 hp	125	0.4	0.7	2.5	5.0	—
305 hp	111	0.1	0.5	1.8	3.6	0.9
405 hp	97	0.08	0.1	1.2	2.1	0.3

\*May be used with most types of raking tools and angled shearing blade. Windrows to be spaced approximately 61 meters (200 feet) apart.

**Explanation of columns in table:**

*Tractor* — Production with tractor working alone based on current model tractors (power shift when applicable) working on reasonably level (below 10% grade) terrain with good footing, no stones, average mixture of soft and hard woods. The tractor is in proper operating condition. Decrease total time by 25-50% depending on the number and size of trees when using three or more tractors in combination.

*Base Minutes* — The base figures represent the number of minutes required for each tractor to cover a hectare (2.47 acres) of light material.

*Dia. Range* —  $M_1$  represents minutes required to pile trees from 31-60 cm (1-2 ft) diameter at ground level.

$M_2$  same for trees 61-90 cm (2-3 ft) diameter.

$M_3$  same for trees 91-120 cm (3-4 ft) diameter.

$M_4$  same for trees 121-180 cm (4-6 ft) diameter.

*For Dia. above 180 cm (6 ft)* — The figures in this column represent for each tractor size the number of minutes required per 30 cm (1 ft) of diameter to pile trees above 180 cm (6 ft) in diameter. Thus, to pile a 240 cm (8 ft) diameter tree would require  $8 \times 0.9$  or approximately 7.2 minutes with a D8T tractor.

Where the job requires piling of grubbed trees and stumps greater than 30 cm (1 ft) in diameter, use the same basic procedure defined above and then increase over-all or total time by 25%.

In dense small diameter brush with few or no large trees, or when cutting is vine entangled, reduce the base time by 30%.

Example problem:

Calculate the windrow piling production of a D7R Series 2 with Rake in level terrain, no grubbing, and average mixture of hardwoods and softwoods where the average tree count per hectare (2.47 acres) is:

Diameter Range	Less than 30 cm (1 ft) "B"	31-60 cm (1-2 ft) "N <sub>1</sub> "	61-90 cm (2-3 ft) "N <sub>2</sub> "	91-120 cm (3-4 ft) "N <sub>3</sub> "	121-180 cm (4-6 ft) "N <sub>4</sub> "	Sum Dia's Above 180 cm (6 ft) "D"
Number of Trees	1100	35	6	6	2	0

**Solution:**

$$\begin{aligned}
 T &= B + M_1N_1 + M_2N_2 + M_3N_3 + M_4N_4 + DF \\
 &= 125 + 0.4(35) + 0.6(6) + 2.5(6) + 5.0(2) + [DF=0] \\
 &= 42.6 \\
 &= 177.6 \text{ minutes/hectare (72 min/acre)}
 \end{aligned}$$



To find the number of machines required for each operation, use the formula:

$$\text{Hr/hectare (acre)} \times \text{number of hectares (acres)} = \text{number of machines needed}^*$$

\*Average machine production for all operation in hr/hectare (acre).

To cost estimate each method or phase of operation, use this calculation:

$$\text{Owning and Operating cost/hr} \times \text{hr/hectare (acre)} \times \text{number of hectares (acres)} = \text{cost}$$

Because of the many variables that increase or decrease production, these formulas should be considered only as guidelines in arriving at a rough production estimate. This estimate should be tempered by personal judgment based on past experience and personal knowledge of the area.

**BLADE RAKES**

Tractor Model and Dozer		D6T			D7R Series 2		
		6A	6S	6S LGP	7A	7S	7S LGP
Raking Width	m	3.3	2.62	3.3	3.72	3.18	3.66
	ft	<b>10'10"</b>	<b>8'6"</b>	<b>10'10"</b>	<b>12'3"</b>	<b>10'5"</b>	<b>12'</b>
Opening at Tooth Tips	mm	356	305	310	381	381	381
	in	<b>14"</b>	<b>12"</b>	<b>12.22"</b>	<b>15"</b>	<b>15"</b>	<b>15"</b>
Tooth Penetration	mm	432	457	406	559	559	559
	ft/in	<b>17"</b>	<b>18"</b>	<b>16"</b>	<b>1'10"</b>	<b>1'10"</b>	<b>1'10"</b>
Total Weight	kg	718	675	825	1144	1100	1119
	lb	<b>1585</b>	<b>1490</b>	<b>1820</b>	<b>2525</b>	<b>2420</b>	<b>2470</b>

**RAKES FOR WHEEL LOADERS**

Wheel Loader Model and Rake Type		910K/ 914K/ 910M/ 914M/ 918M Loader Rake	924K/ 926M Loader Rake		930K/ 930M Loader Rake		938K/ 938M Loader Rake		950K/ 950M/ 962K/ 962M Loader Rake	966K/ 966M/ 972K/ 972M Loader Rake
		Raking Width	mm	2210	2146	2495	2146	2495	2495	2844
	ft	<b>7'3"</b>	<b>7'0"</b>	<b>8'2"</b>	<b>7'0"</b>	<b>8'2"</b>	<b>8'2"</b>	<b>9'4"</b>	<b>9'4"</b>	<b>10'4"</b>
Tooth Penetration	mm	762	520	520	520	520	520	520	520	559
	ft	<b>2'6"</b>	<b>1'8"</b>	<b>1'8"</b>	<b>1'8"</b>	<b>1'8"</b>	<b>1'8"</b>	<b>1'8"</b>	<b>1'8"</b>	<b>1'10"</b>
Opening at Tooth Tips	mm	318	299	299	299	299	299	299	299	330
	in	<b>12.75"</b>	<b>12"</b>	<b>12"</b>	<b>12"</b>	<b>12"</b>	<b>12"</b>	<b>12"</b>	<b>12"</b>	<b>13"</b>
Rake Weight	kg	770	1960	1338	1960	1338	1338	2230	1477	2085
	lb	<b>1700</b>	<b>4322</b>	<b>2950</b>	<b>4322</b>	<b>2950</b>	<b>2950</b>	<b>4917</b>	<b>3257</b>	<b>4597</b>

27

**RAKES FOR TRACK LOADERS**

Track Loader Model and Rake Type		953D Loader Rake	963D Loader Rake
Raking Width	mm	2845	2388
	ft	<b>9'4"</b>	<b>7'10"</b>
Tooth Penetration	mm	635	635
	ft	<b>2'1"</b>	<b>2'1"</b>
Opening at Tooth Tips	mm	298	330
	in	<b>11.75"</b>	<b>13"</b>
Rake Weight	kg	1450	1450
	lb	<b>3200</b>	<b>3200</b>

This listing is not all-inclusive. Contact your Cat dealer for special attachment needs.





# MINING AND EARTHMOVING

## CONTENTS

Elements of Production . . . . .	28-1
Volume Measure . . . . .	28-2
Swell . . . . .	28-2
Load Factor . . . . .	28-2
Material Density . . . . .	28-2
Fill Factor . . . . .	28-3
Soil Density Tests . . . . .	28-3
Figuring Production On-the-Job . . . . .	28-4
Load Weighing . . . . .	28-4
Time Studies . . . . .	28-4
English Example . . . . .	28-4
Metric Example . . . . .	28-5
Estimating Production Off-the-Job . . . . .	28-5
Rolling Resistance . . . . .	28-5
Grade Resistance . . . . .	28-6
Total Resistance . . . . .	28-6
Traction . . . . .	28-6
Altitude . . . . .	28-7
Job Efficiency . . . . .	28-8
English Example . . . . .	28-8
Metric Example . . . . .	28-10
Systems . . . . .	28-13
Economic Haul Distances . . . . .	28-13
Production Estimating . . . . .	28-14
Loading Match . . . . .	28-14
Fuel Consumption and Productivity . . . . .	28-14
Formulas and Rules of Thumb . . . . .	28-15

## INTRODUCTION

This section explains the earthmoving principles used to determine machine productivity. It shows how to calculate production on-the-job or estimate production off-the-job.

## ELEMENTS OF PRODUCTION

Production is the hourly rate at which material is moved. Production can be expressed in various units:

### Metric

- Bank Cubic Meters — BCM — bank m<sup>3</sup>
- Loose Cubic Meters — LCM — loose m<sup>3</sup>
- Compacted Cubic Meters — CCM — compacted m<sup>3</sup>
- Tonnes

### English

- Bank Cubic Yards — BCY — bank yd<sup>3</sup>
- Loose Cubic Yards — LCY — loose yd<sup>3</sup>
- Compacted Cubic Yards — CCY — compacted yd<sup>3</sup>
- Tons

For most earthmoving and material handling applications, production is calculated by multiplying the quantity of material (load) moved per cycle by the number of cycles per hour.

$$\text{Production} = \text{Load/cycle} \times \text{cycles/hour}$$

The load can be determined by

- 1) load weighing with scales
- 2) load estimating based on machine rating
- 3) surveyed volume divided by load count
- 4) machine payload measurement system

Generally, earthmoving and overburden removal for coal mines are calculated by volume (bank cubic meters or bank cubic yards). Metal mines and aggregate producers usually work in weight (tons or tonnes).

**Volume Measure** — Material volume is defined according to its state in the earthmoving process. The three measures of volume are:

- BCM (BCY) — one cubic meter (yard) of material as it lies in the natural bank state.
- LCM (LCY) — one cubic meter (yard) of material which has been disturbed and has swelled as a result of movement.
- CCM (CCY) — one cubic meter (yard) of material which has been compacted and has become more dense as a result of compaction.

In order to estimate production, the relationships between bank measure, loose measure, and compacted measure must be known.

**Swell** — Swell is the percentage of original volume (cubic meters or cubic yards) that a material increases when it is removed from the natural state. When excavated, the material breaks up into different size particles that do not fit together, causing air pockets or voids to reduce the weight per volume. For example to hold the same weight of one cubic unit of bank material it takes 30% more volume (1.3 times) after excavation. (Swell is 30%.)

$$1 + \text{Swell} = \frac{\text{Loose cubic volume for a given weight}}{\text{Bank cubic volume for the same given weight}}$$

$$\text{Bank} = \frac{\text{Loose}}{(1 + \text{Swell})}$$

$$\text{Loose} = \text{Bank} \times (1 + \text{Swell})$$

Example Problem:

If a material swells 20%, how many loose cubic meters (loose cubic yards) will it take to move 1000 bank cubic meters (1308 bank cubic yards)?

$$\begin{aligned} \text{Loose} &= \text{Bank} \times (1 + \text{Swell}) = \\ &1000 \text{ BCM} \times (1 + 0.2) = 1200 \text{ LCM} \\ &1308 \text{ BCY} \times (1 + 0.2) = 1570 \text{ LCY} \end{aligned}$$

How many bank cubic meters (yards) were moved if a total of 1000 loose cubic meters (1308 yards) have been moved? Swell is 25%.

$$\begin{aligned} \text{Bank} &= \text{Loose} \div (1 + \text{Swell}) = \\ &1000 \text{ LCM} \div (1 + 0.25) = 800 \text{ BCM} \\ &1308 \text{ LCY} \div (1 + 0.25) = 1046 \text{ BCY} \end{aligned}$$

**Load Factor** — Assume one bank cubic yard of material weighs 3000 lb. Because of material characteristics, this bank cubic yard swells 30% to 1.3 loose cubic yards when loaded, with no change in weight. If this 1.0 bank cubic yard or 1.3 loose cubic yards is compacted, its volume may be reduced to 0.8 compacted cubic yard, and the weight is still 3000 lb.

Instead of dividing by 1 + Swell to determine bank volume, the loose volume can be multiplied by the load factor.

If the percent of material swell is known, the load factor (L.F.) may be obtained by using the following relationship:

$$\text{L.F.} = \frac{100\%}{100\% + \% \text{ swell}}$$

Load factors for various materials are listed in the Tables Section of this handbook.

To estimate the machine payload in bank cubic yards, the volume in loose cubic yards is multiplied by the load factor:

$$\text{Load (BCY)} = \text{Load (LCY)} \times \text{L.F.}$$

The ratio between compacted measure and bank measure is called shrinkage factor (S.F.):

$$\text{S.F.} = \frac{\text{Compacted cubic yards (CCY)}}{\text{Bank cubic yards (BCY)}}$$

Shrinkage factor is either estimated or obtained from job plans or specifications which show the conversion from compacted measure to bank measure. Shrinkage factor should not be confused with percentage compaction (used for specifying embankment density, such as Modified Proctor or California Bearing Ratio [CBR]).

**Material Density** — Density is the weight per unit volume of a material. Materials have various densities depending on particle size, moisture content and variations in the material. The denser the material the more weight there is per unit of equal volume. Density estimates are provided in the Tables Section of this handbook.

$$\text{Density} = \frac{\text{Weight}}{\text{Volume}} = \frac{\text{kg (lb)}}{\text{m}^3 (\text{yd}^3)}$$

$$\text{Weight} = \text{Volume} \times \text{Density}$$

A given material's density changes between bank and loose. One cubic unit of loose material has less weight than one cubic unit of bank material due to air pockets and voids. To correct between bank and loose use the following equations.

$$1 + \text{Swell} = \frac{\text{kg/BCM}}{\text{kg/LCM}} \text{ or } \frac{\text{lb/BCY}}{\text{lb/LCY}}$$

$$\text{lb/LCY} = \frac{\text{lb/BCY}}{(1 + \text{Swell})}$$

$$\text{lb/BCY} = \text{lb/LCY} \times (1 + \text{Swell})$$

**Fill Factor** — The percentage of an available volume in a body, bucket, or bowl that is actually used is expressed as the fill factor. A fill factor of 87% for a hauler body means that 13% of the rated volume is not being used to carry material. Buckets often have fill factors over 100%.

Example Problem:

A 14 cubic yard (heaped 2:1) bucket has a 105% fill factor when operating in a shot sandstone (4125 lb/BCY and a 35% swell).

- What is the loose density of the material?
  - What is the usable volume of the bucket?
  - What is the bucket payload per pass in BCY?
  - What is the bucket payload per pass in tons?
- $\text{lb/LCY} = \text{lb/BCY} \div (1 + \text{Swell}) = 4125 \div (1.35) = 3056 \text{ lb/LCY}$
  - $\text{LCY} = \text{rated LCY} \times \text{fill factor} = 14 \times 1.05 = 14.7 \text{ LCY}$
  - $\text{lb/pass} = \text{volume} \times \text{density lb/LCY} = 14.7 \times 3056 = 44,923 \text{ lb}$   
 $\text{BCY/pass} = \text{weight} \div \text{density lb/BCY} = 44,923 \div 4125 = 10.9 \text{ BCY}$   
 or bucket LCY from part b  $\div (1 + \text{Swell}) = 14.7 \div 1.35 = 10.9 \text{ BCY}$
  - $\text{tons/pass} = \text{lb} \div 2000 \text{ lb/ton} = 44,923 \div 2000 = 22.5 \text{ tons}$

Example Problem:

Construct a 10,000 compacted cubic yard (CCY) bridge approach of dry clay with a shrinkage factor (S.F.) of 0.80. Haul unit is rated 14 loose cubic yards struck and 20 loose cubic yards heaped.

- How many bank yards are needed?
- How many loads are required?

$$\text{a) } \text{BCY} = \frac{\text{CCY}}{\text{S.F.}} = \frac{10,000}{0.80} = 12,500 \text{ BCY}$$

$$\text{b) } \text{Load (BCY)} = \text{Capacity (LCY)} \times \text{Load factor (L.F.)} = 20 \times 0.81 = 16.2 \text{ BCY/Load}$$

(L.F. of 0.81 from Tables)

$$\text{Number of loads required} = \frac{12,500 \text{ BCY}}{16.2 \text{ BCY/Load}} = 772 \text{ Loads}$$



**Soil Density Tests** — There are a number of acceptable methods that can be used to determine soil density. Some that are currently in use are:

- Nuclear density moisture gauge
- Sand cone method
- Oil method
- Balloon method
- Cylinder method

All these except the nuclear method use the following procedure:

- Remove a soil sample from bank state.
- Determine the volume of the hole.
- Weigh the soil sample.
- Calculate the bank density kg/BCM (lb/BCY).

The nuclear density moisture gauge is one of the most modern instruments for measuring soil density and moisture. A common radiation channel emits either neutrons or gamma rays into the soil. In determining soil density, the number of gamma rays absorbed and back scattered by soil particles is *indirectly* proportional to the soil density. When measuring moisture content, the number of moderated neutrons reflected back to the detector after colliding with hydrogen particles in the soil is *directly* proportional to the soil's moisture content.

All these methods are satisfactory and will provide accurate densities when performed correctly. Several repetitions are necessary to obtain an average.

**NOTE:** Several newer methods have been successfully applied, along with weigh scales to determine volume and loose density of material moved in hauler bodies. These measurements include photographic and laser scanning technologies.

- Load Weighing
- Time Studies
- Example (English)

**FIGURING PRODUCTION ON-THE-JOB**

**Load Weighing** — The most accurate method of determining the actual load carried is by weighing. This is normally done by weighing the haul unit one wheel or axle at a time with portable scales. Any scales of adequate capacity and accuracy can be used. While weighing, the machine must be level to reduce error caused by weight transfer. Enough loads must be weighed to provide a good average. Machine weight is the sum of the individual wheel or axle weights.

The weight of the load can be determined using the empty and loaded weight of the unit.

Weight of

$$\text{load} = \text{gross machine weight} - \text{empty weight}$$

To determine the bank cubic measure carried by a machine, the load weight is divided by the bankstate density of the material being hauled.

$$\text{BCY} = \frac{\text{Weight of load}}{\text{Bank density}}$$

**Times Studies** — To estimate production, the number of complete trips a unit makes per hour must be determined. First obtain the unit's cycle time with the help of a stop watch. Time several complete cycles to arrive at an average cycle time. By allowing the watch to run continuously, different segments such as load time, wait time, etc. can be recorded for each cycle. Knowing the individual time segments affords a good opportunity to evaluate the balance of the spread and job efficiency. The following is an example of a scraper load time study form. Numbers in the white columns are stop watch readings; numbers in the shaded columns are calculated:

Total Cycle Times (less delays)	Arrive Cut	Wait Time	Begin Load	Load Time	End Load	Begin Delay	Delay Time	End Delay
	0.00	0.30	0.30	0.60	0.90			
3.50	3.50	0.30	3.80	0.65	4.45			
4.00	7.50	0.35	7.85	0.70	8.55	9.95	1.00	10.95
4.00	12.50	0.42	12.92	0.68	13.60			

**NOTE:** All numbers are in minutes

This may be easily extended to include other segments of the cycle such as haul time, dump time, etc. Haul roads may be further segmented to more accurately define performance, including measured speed traps. Similar forms can be made for pushers, loaders, dozers, etc. *Wait Time* is the time a unit must wait for another unit so that the two can function together (haul unit waiting for pusher). *Delay Time* is any time, other than wait time, when a machine is not performing in the work cycle (scraper waiting to cross railroad track).

To determine trips-per-hour at 100% efficiency, divide 60 minutes by the average cycle time less all wait and delay time. Cycle time may or may not include wait and/or delay time. Therefore, it is possible to figure different kinds of production: measured production, production without wait or delay, maximum production, etc. For example:

Actual Production: includes all wait and delay time.

Normal Production (without delays): includes wait time that is considered normal, but no delay time.

Maximum Production: to figure maximum (or optimum) production, both wait time and delay time are eliminated. The cycle time may be further altered by using an optimum load time.

Example (English)

A job study of a Wheel Tractor-Scraper might yield the following information:

- Average wait time = 0.28 minute
- Average load time = 0.65
- Average delay time = 0.25
- Average haul time = 4.26
- Average dump time = 0.50
- Average return time = 2.09
- Average total cycle = 8.03 minutes
- Less wait & delay time = 0.53
- Average cycle 100% eff. = 7.50 minutes

Weight of haul unit empty — 48,650 lb

Weights of haul unit loaded —

- Weighing unit #1 — 93,420 lb
- Weighing unit #2 — 89,770 lb
- Weighing unit #3 — 88,760 lb

$$\frac{271,950 \text{ lb}}{\text{average}} = 90,650 \text{ lb}$$

1. Average load weight = 90,650 lb – 48,650 lb = 42,000 lb
2. Bank density = 3125 lb/BCY

$$\begin{aligned} 3. \text{ Load} &= \frac{\text{Weight of load}}{\text{Bank density}} \\ &= \frac{42,000 \text{ lb}}{3125 \text{ lb/BCY}} = 13.4 \text{ BCY} \end{aligned}$$

$$4. \text{ Cycles/hr} = \frac{60 \text{ min/hr}}{\text{Cycle time}} = \frac{60 \text{ min/hr}}{7.50 \text{ min/cycle}} = 80 \text{ cycles/hr}$$

$$\begin{aligned} 5. \text{ Production} &= \text{Load/cycle} \times \text{cycles/hr} \\ (\text{less delays}) &= 13.4 \text{ BCY/cycle} \times 8.0 \text{ cycles/hr} \\ &= 107.2 \text{ BCY/hr} \end{aligned}$$

Example (Metric)

A job study of a Wheel Tractor-Scraper might yield the following information:

Average wait time	= 0.28 minute
Average load time	= 0.65
Average delay time	= 0.25
Average haul time	= 4.26
Average dump time	= 0.50
Average return time	= 2.09
Average total cycle	= 8.03 minutes
Less wait & delay time	= 0.53
Average cycle 100% eff.	= 7.50 minutes

Weight of haul unit empty — 22 070 kg

Weights of haul unit loaded —

Weighing unit #1	— 42 375 kg
Weighing unit #2	— 40 720 kg
Weighing unit #3	— 40 260 kg

123 355 kg;  
average = 41 120 kg

1. Average load weight = 41 120 kg – 22 070 kg = 19 050 kg
2. Bank density = 1854 kg/BCM
3. Load =  $\frac{\text{Weight of load}}{\text{Bank density}}$   
 $= \frac{19\,050\text{ kg}}{1854\text{ kg/BCM}} = 10.3\text{ BCM}$
4. Cycles/hr =  $\frac{60\text{ min/hr}}{\text{Cycle time}} = \frac{60\text{ min/hr}}{7.50\text{ min/cycle}} = 80\text{ cycles/hr}$
5. Production = Load/cycle × cycles/hr  
 (less delays) = 10.3 BCM/cycle × 8.0 cycles/hr  
 = 82 BCM/hrr



**ESTIMATING PRODUCTION OFF-THE-JOB**

It is often necessary to estimate production of earthmoving machines which will be selected for a job. As a guide, the remainder of the section is devoted to discussions of various factors that may affect production. Some of the figures have been rounded for easier calculation.

**Rolling Resistance (RR)** is a measure of the force that must be overcome to roll or pull a wheel over the ground. It is affected by ground conditions and load — the deeper a wheel sinks into the ground, the higher the rolling resistance. Internal friction and tire flexing also contribute to rolling resistance. Experience has shown that minimum resistance is 1%-1.5% (see Typical Rolling Resistance Factors in Tables section) of the gross machine weight (on tires). A 2% base resistance is quite often used for estimating. Resistance due to tire penetration is approximately 1.5% of the gross machine weight for each inch of tire penetration (0.6% for each cm of tire penetration). Thus rolling resistance can be calculated using these relationships in the following manner:

$$\text{RR} = 2\% \text{ of GMW} + 0.6\% \text{ of GMW per cm tire penetration}$$

$$\text{RR} = 2\% \text{ of GMW} + 1.5\% \text{ of GMW per inch tire penetration}$$

It's *not* necessary for the tires to actually penetrate the road surface for rolling resistance to increase above the minimum. If the road surface flexes under load, the effect is nearly the same — the tire is always running “uphill.” Only on very hard, smooth surfaces with a well compacted base will the rolling resistance approach the minimum.

When actual penetration takes place, some variation in rolling resistance can be noted with various inflation pressures and tread patterns.

**NOTE:** When figuring “pull” requirements for track-type tractors, rolling resistance applies only to the trailed unit's *weight on wheels*. Since track-type tractors utilize steel wheels moving on steel “roads,” a tractor's rolling resistance is relatively constant and is accounted for in the Drawbar Pull rating.

- Grade Resistance
- Total Resistance
- Traction

**Grade Resistance** is a measure of the force that must be overcome to move a machine over unfavorable grades (uphill). Grade assistance is a measure of the force that assists machine movement on favorable grades (downhill).

Grades are generally measured in percent slope, which is the ratio between vertical rise or fall and the horizontal distance in which the rise or fall occurs. For example, a 1% grade is equivalent to a 1 m (ft) rise or fall for every 100 m (ft) of horizontal distance; a rise of 4.6 m (15 ft) in 53.3 m (175 ft) equals an 8.6% grade.

$$\frac{4.6 \text{ m (rise)}}{53.3 \text{ m (horizontal distance)}} = 8.6\% \text{ grade}$$

$$\frac{15 \text{ ft (rise)}}{175 \text{ ft (horizontal distance)}} = 8.6\% \text{ grade}$$

Uphill grades are normally referred to as adverse grades and downhill grades as favorable grades. Grade resistance is usually expressed as a positive (+) percentage and grade assistance is expressed as a negative (–) percentage.

It has been found that for each 1% increment of adverse grade an additional 10 kg (20 lb) of resistance must be overcome for each metric (U.S.) ton of machine weight. This relationship is the basis for determining the Grade Resistance Factor which is expressed in kg/metric ton (lb/U.S. ton):

$$\begin{aligned} \text{Grade Resistance Factor} &= 10 \text{ kg/m ton} \times \% \text{ grade} \\ &= 20 \text{ lb/U.S. ton} \times \% \text{ grade} \end{aligned}$$

Grade resistance (assistance) is then obtained by multiplying the Grade Resistance Factor by the machine weight (GMW) in metric (U.S.) tons.

$$\text{Grade Resistance} = \text{GR Factor} \times \text{GMW in metric (U.S.) tons}$$

Grade resistance may also be calculated using percentage of gross weight. This method is based on the relationship that grade resistance is approximately equal to 1% of the gross machine weight for 1% of grade.

$$\text{Grade Resistance} = 1\% \text{ of GMW} \times \% \text{ grade}$$

Grade resistance (assistance) affects both wheel and track-type machines.

**Total Resistance** is the combined effect of rolling resistance (wheel vehicles) and grade resistance. It can be computed by summing the values of rolling resistance and grade resistance to give a resistance in kilogram (pounds) force.

$$\text{Total Resistance} = \text{Rolling Resistance} + \text{Grade Resistance}$$

Total resistance can also be represented as consisting completely of grade resistance expressed in percent grade. In other words, the rolling resistance component is viewed as a corresponding quantity of additional adverse grade resistance. Using this approach, total resistance can then be considered in terms of percent grade.

This can be done by converting the contribution of rolling resistance into a corresponding percentage of grade resistance. Since 1% of adverse grade offers a resistance of 10 kg (20 lb) for each metric or (U.S.) ton of machine weight, then each 10 kg (20 lb) of resistance per ton of machine weight can be represented as an additional 1% of adverse grade. Rolling resistance in percent grade and grade resistance in percent grade can then be summed to give Total Resistance in percent or Effective Grade. The following formulas are useful in arriving at Effective Grade.

$$\begin{aligned} \text{Rolling Resistance (\%)} &= 2\% + 0.6\% \text{ per cm tire penetration} \\ &= 2\% + 1.5\% \text{ per inch tire penetration} \end{aligned}$$

$$\begin{aligned} \text{Grade Resistance (\%)} &= \% \text{ grade} \\ \text{Effective Grade (\%)} &= \text{RR (\%)} + \text{GR (\%)} \end{aligned}$$

Effective grade is a useful concept when working with Rimpull-Speed-Gradeability curves, Retarder curves, Brake Performance curves, and Travel Time curves.

**Traction** — is the driving force developed by a wheel or track as it acts upon a surface. It is expressed as usable Drawbar Pull or Rimpull. The following factors affect traction: weight on the driving wheel or tracks, gripping action of the wheel or track, and ground conditions. The coefficient of traction (for any roadway) is the ratio of the maximum pull developed by the machine to the total weight on the drivers.

$$\text{Coeff. of traction} = \frac{\text{Pull}}{\text{weight on drivers}}$$

Therefore, to find the usable pull for a given machine:  
Usable pull = Coeff. of traction × weight on drivers

### Example: Track-Type Tractor

What usable drawbar pull (DBP) can a 26 800 kg (59,100 lb) Track-type Tractor exert while working on firm earth? on loose earth? (See table section for coefficient of traction.)

Answer:

Firm earth — Usable DBP =  
 $0.90 \times 26\,800 \text{ kg} = 24\,120 \text{ kg}$   
 $(0.90 \times 59,100 \text{ lb} = 53,190 \text{ lb})$   
 Loose earth — Usable DBP =  
 $0.60 \times 26\,800 \text{ kg} = 16\,080 \text{ kg}$   
 $(0.60 \times 59,100 \text{ lb} = 35,460 \text{ lb})$

If a load required 21 800 kg (48,000 lb) pull to move it, this tractor could move the load on firm earth. However, if the earth were loose, the tracks would spin.

**NOTE:** D8R through D11R Tractors may attain higher coefficients of traction due to their suspended undercarriage.

Example: Wheel Tractor-Scraper

What usable rimpull can a 621F size machine exert while working on firm earth? on loose earth? The total loaded weight distribution of this unit is:

Drive unit	Scraper unit
wheels: 23 600 kg	wheels: 21 800 kg
(52,000 lb)	(48,000 lb)

Remember, use weight on drivers only.  
 Answer:

Firm earth —  $0.55 \times 23\,600 \text{ kg} = 12\,980 \text{ kg}$   
 $(0.55 \times 52,000 \text{ lb} = 28,600 \text{ lb})$   
 Loose earth —  $0.45 \times 23\,600 \text{ kg} = 10\,620 \text{ kg}$   
 $(0.45 \times 52,000 \text{ lb} = 23,400 \text{ lb})$

On firm earth this unit can exert up to 12 980 kg (28,600 lb) rimpull without excessive slipping. However, on loose earth the drivers would slip if more than 10 620 kg (23,400 lb) rimpull were developed.



**Altitude** — Specification sheets show how much pull a machine can produce for a given gear and speed when the engine is operating at rated horsepower. When a standard machine is operated in high altitudes, the engine may require derating to maintain normal engine life. This engine derating will produce less drawbar pull or rimpull.

The Tables Section gives the altitude deration in percent of flywheel horsepower for current machines. It should be noted that some turbocharged engines can operate up to 4570 m (15,000 ft) before they require derating. Most machines are engineered to operate up to 1500-2290 m (5000-7500 ft) before they require deration.

The horsepower deration due to altitude must be considered in any job estimating. The amount of power deration will be reflected in the machine's gradeability and in the load, travel, and dump and load times (unless loading is independent of the machine itself). Altitude may also reduce retarding performance. Consult a Cat representative to determine if deration is applicable. Fuel grade (heat content) can have a similar effect of derating engine performance.

The example job problem that follows indicates one method of accounting for altitude deration: by increasing the appropriate components of the total cycle time by a percentage equal to the percent of horsepower deration due to altitude. (i.e., if the travel time of a hauling unit is determined to be 1.00 minute at full HP, the time for the same machine derated to 90% of full HP will be 1.10 min.) This is an approximate method that yields reasonably accurate estimates up to 3000 m (10,000 feet) elevation.

Travel time for hauling units derated more than 10% should be calculated as follows using Rimpull-Speed-Gradeability charts.

1) Determine total resistance (grade plus rolling) in percent.

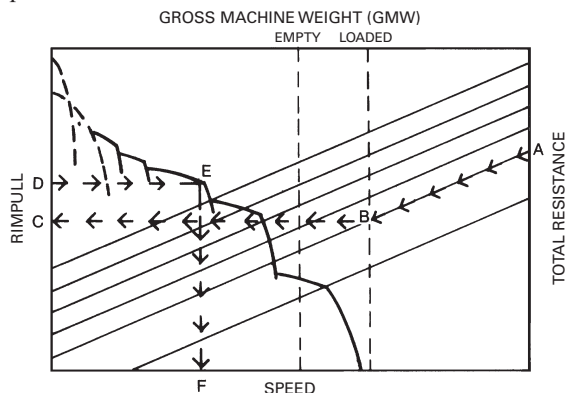

2) Beginning at point A on the chart follow the total resistance line diagonally to its intersection, B, with the vertical line corresponding to the appropriate gross machine weight. (Rated loaded and empty GMW lines are shown dotted.)

3) Using a straight-edge, establish a horizontal line to the left from point B to point C on the rim-pull scale.

4) Divide the value of point C as read on the rim-pull scale by the percent of total horsepower available after altitude deration from the Tables Section. This yields rimpull value D higher than point C.



## Mining and Earthmoving

### Estimating Production Off-the-Job

- Job Efficiency
- Example Problem (English)

5) Establish a horizontal line right from point D. The farthest right intersection of this line with a curved speed range line is point E.

6) A vertical line down from point E determines point F on the speed scale.

7) Multiply speed in kmh by 16.7 (mph by 88) to obtain speed in m/min (ft/min). Travel time in minutes for a given distance in feet is determined by the formula:

$$\text{Time (min)} = \frac{\text{Distance in m (ft)}}{\text{Speed in m/min (ft/min)}}$$

The *Travel Time Graphs* in sections on Wheel Tractor-Scrapers and Construction & Mining Trucks can be used as an alternative method of calculating haul and/or return times.



The following example provides a method to manually estimate production and cost. Today, computer programs, such as Caterpillar's Fleet Production and Cost Analysis (FPC), provide a much faster and more accurate means to obtain those application results.

#### Example problem (English)

A contractor is planning to put the following spread on a dam job. What is the estimated production?

#### Equipment:

- 11 — 631G Wheel Tractor-Scrapers
- 2 — D9T Tractors with C-dozers
- 2 — 12H Motor Graders
- 1 — 825G Tamping Foot Compactor

#### Material:

- Description — Sandy clay; damp, natural bed
- Bank Density — 3000 lb/BCY
- Load Factor — 0.80
- Shrinkage Factor — 0.85
- Traction Factor — 0.50
- Altitude — 7500 ft

#### Job Layout — Haul and Return:

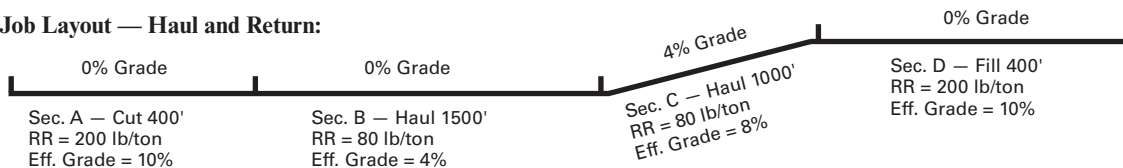

#### Total Effective Grade = RR (%) ± GR (%)

Sec. A: Total Effective Grade = 10% + 0% = 10%

Sec. B: Total Effective Grade = 4% + 0% = 4%

Sec. C: Total Effective Grade = 4% + 4% = 8%

Sec. D: Total Effective Grade = 10% + 0% = 10%

**Job Efficiency** is one of the most complex elements of estimating production since it is influenced by factors such as operator skill, minor repairs and adjustments, personnel delays, and delays caused by job layout. An approximation of efficiency, if no job data is available, is given below.

Operation	Working Hour	Efficiency Factor
Day	50 min/hr	0.83
Night	45 min/hr	0.75

These factors do not account for delays due to weather or machine downtime for maintenance and repairs. You must account for such factors based on experience and local conditions.

#### 1. Estimate Payload:

Est. load (LCY) × L.F. × Bank Density = payload  
 31 LCY × 0.80 × 3000 lb/BCY = 74,400 lb payload

#### 2. Establish Machine Weight:

Empty Wt. — 102,460 lb or 51.27 tons  
 Wt. of Load — 74,400 lb or 37.2 tons  
 Total (GMW) — 176,860 lb or 88.4 tons

#### 3. Calculate Usable Pull (traction limitation):

Loaded: (weight on driving wheels = 54%) (GMW)

Traction Factor × Wt. on driving wheels =  
 0.50 × 176,860 lb × 54% = 47,628 lb

Empty: (weight on driving wheels = 69%) (GMW)

Traction Factor × Wt. on driving wheels =  
 0.50 × 102,460 lb × 69% = 35,394 lb

#### 4. Derate for Altitude:

Check power available at 7500 ft from altitude deration table in the Tables Section.

631G — 100%                      12H — 83%  
 D9T — 100%                      825G — 100%

Then adjust if necessary:

*Load Time* — controlled by D9T, at 100% power, no change.

*Travel, Maneuver and Spread time* — 631G, no change.

**5. Compare Total Resistance to Tractive Effort on haul:**

*Grade Resistance* —

GR = lb/ton × tons × adverse grade in percent

$$\text{Sec. C:} = 20 \text{ lb/ton} \times 88.4 \text{ tons} \times 4\% \text{ grade} = 7072 \text{ lb}$$

*Rolling Resistance* —

RR = RR Factor (lb/ton) × GMW (tons)

$$\text{Sec. A:} = 200 \text{ lb/ton} \times 88.4 \text{ tons} = 17,686 \text{ lb}$$

$$\text{Sec. B:} = 80 \text{ lb/ton} \times 88.4 \text{ tons} = 7072 \text{ lb}$$

$$\text{Sec. C:} = 80 \text{ lb/ton} \times 88.4 \text{ tons} = 7072 \text{ lb}$$

$$\text{Sec. D:} = 200 \text{ lb/ton} \times 88.4 \text{ tons} = 17,686 \text{ lb}$$

*Total Resistance* —

TR = RR + GR

$$\text{Sec. A:} = 17,686 \text{ lb} + 0 = 17,686 \text{ lb}$$

$$\text{Sec. B:} = 7072 \text{ lb} + 0 = 7072 \text{ lb}$$

$$\text{Sec. C:} = 7072 \text{ lb} + 6496 \text{ lb} = 14,144 \text{ lb}$$

$$\text{Sec. D:} = 17,686 \text{ lb} + 0 = 17,686 \text{ lb}$$

Check usable pounds pull against maximum pounds pull required to move the 631G.

Pull usable ... 47,628 lb loaded

Pull required ... 17,686 lb maximum total resistance

Estimate travel time for haul from 631G (loaded) travel time curve; read travel time from distance and effective grade.

Travel time (from curves):

$$\text{Sec. A:} 0.60 \text{ min}$$

$$\text{Sec. B:} 1.00$$

$$\text{Sec. C:} 1.20$$

$$\text{Sec. D:} 0.60$$

$$\underline{\quad\quad\quad} \\ 3.40 \text{ min}$$

**NOTE:** This is an estimate only; it *does not account for all the acceleration and deceleration time*, therefore it is not as accurate as the information obtained from a computer program.

**6. Compare Total Resistance to Tractive Effort on return:**

*Grade Assistance* —

GA = 20 lb/ton × tons × negative grade in percent

$$\text{Sec. C:} = 20 \text{ lb/ton} \times 51.2 \text{ tons} \times 4\% \text{ grade} = 4096 \text{ lb}$$

*Rolling Resistance* —

RR = RR Factor × Empty Wt (tons)

$$\text{Sec. D:} = 200 \text{ lb/ton} \times 51.2 \text{ tons} = 10,240 \text{ lb}$$

$$\text{Sec. C:} = 80 \text{ lb/ton} \times 51.2 \text{ tons} = 4091 \text{ lb}$$

$$\text{Sec. B:} = 80 \text{ lb/ton} \times 51.2 \text{ tons} = 4091 \text{ lb}$$

$$\text{Sec. A:} = 200 \text{ lb/ton} \times 51.2 \text{ tons} = 10,240 \text{ lb}$$

*Total Resistance* —

TR = RR – GA

$$\text{Sec. D:} = 10,240 \text{ lb} - 0 = 10,240 \text{ lb}$$

$$\text{Sec. C:} = 4096 \text{ lb} - 4096 \text{ lb} = 0$$

$$\text{Sec. B:} = 4096 \text{ lb} - 0 = 4096 \text{ lb}$$

$$\text{Sec. A:} = 10,240 \text{ lb} - 0 = 10,240 \text{ lb}$$

Check usable pounds pull against maximum pounds pull required to move the 631G.

Pounds pull usable ... 35,349 lb empty

Pounds pull required ... 10,240 lb

Estimate travel time for return from 631G empty travel time curve.

Travel time (from curves):

$$\text{Sec. A:} 0.40 \text{ min}$$

$$\text{Sec. B:} 0.55$$

$$\text{Sec. C:} 0.80$$

$$\text{Sec. D:} 0.40$$

$$\underline{\quad\quad\quad} \\ 2.15 \text{ min}$$

**7. Estimate Cycle Time:**

$$\text{Total Travel Time (Haul plus Return)} = 5.55 \text{ min}$$

$$\text{Adjusted for altitude: } 100\% \times 5.55 \text{ min} = 5.55 \text{ min}$$

$$\text{Load Time} \quad\quad\quad 0.7 \text{ min}$$

$$\text{Maneuver and Spread Time} \quad\quad\quad 0.7 \text{ min}$$

$$\text{Total Cycle Time} \quad\quad\quad \underline{\quad\quad\quad} \\ 6.95 \text{ min}$$

- Example Problem (English)
- Example Problem (Metric)

**8. Check pusher-scraper combinations:**

Pusher cycle time consists of load, boost, return and maneuver time. Where actual job data is not available, the following may be used.

- Boost time = 0.10 minute
- Return time = 40% of load time
- Maneuver time = 0.15 minute
- Pusher cycle time = 140% of load time + 0.25 minute
- Pusher cycle time = 140% of 0.7 min + 0.25 minute  
= 0.98 + 0.25 = 1.23 minute

Scraper cycle time divided by pusher cycle time indicates the number of scrapers which can be handled by each pusher.

$$\frac{6.95 \text{ min}}{1.23 \text{ min}} = 5.65$$

Each push tractor is capable of handling five plus scrapers. Therefore the two pushers can adequately serve the eleven scrapers.

**9. Estimate Production:**

- Cycles/hour = 60 min ÷ Total cycle time  
= 60 min/hr ÷ 6.95 min/cycle  
= 8.6 cycles/hr
- Estimated load = Heaped capacity × L.F.  
= 31 LCY × 0.80  
= 24.8 BCY
- Hourly unit production = Est. load × cycles/hr  
= 24.8 BCY × 8.6 cycles/hr  
= 213 BCY/hr
- Adjusted production = Efficiency factor × hourly production  
= 0.83 (50 min hour) × 213 BCY  
= 177 BCY/hr
- Hourly fleet production = Unit production × No. of units  
= 177 BCY/hr × 11  
= 1947 BCY/hr

**10. Estimate Compaction:**

- Compaction requirement = S.F. × hourly fleet production  
= 0.85 × 1947 BCY/hr  
= 1655 CCY/hr

Compaction capability (given the following):

- Compacting width, 7.4 ft (W)
- Average compacting speed, 6 mph (S)
- Compacted lift thickness, 7 in (L)
- No. of passes required, 3 (P)

825G production =

$$\begin{aligned} \text{CCY/hr} &= \frac{W \times S \times L \times 16.3}{P} \text{ (conversion constant)} \\ &= \frac{7.4 \times 6 \times 7 \times 16.3}{3} \\ &= 1688 \text{ CCY/hr} \end{aligned}$$

Given the compaction requirement of 1655 CCY/hr, the 825G is an adequate compactor match-up for the rest of the fleet. However, any change to job layout that would increase fleet production would upset this balance.



Example problem (Metric)

A contractor is planning to put the following spread on a dam job. What is the estimated production?

**Equipment:**

- 11 — 631G Wheel Tractor-Scrapers
- 2 — D9T Tractors with C-dozers
- 2 — 12H Motor Graders
- 1 — 825G Tamping Foot Compactor

**Material:**

- Description — Sandy clay; damp, natural bed
- Bank Density — 1770 kg/BCM
- Load Factor — 0.80
- Shrinkage Factor — 0.85
- Traction Factor — 0.50
- Altitude — 2300 meters

**Job Layout — Haul and Return:**

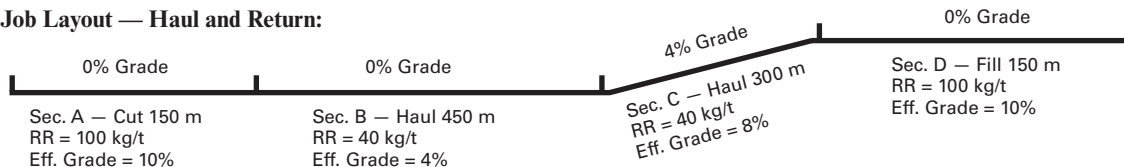

**Total Effective Grade = RR (%) ± GR (%)**

**Sec. A:** Total Effective Grade = 10% + 0% = 10%

**Sec. B:** Total Effective Grade = 4% + 0% = 4%

**Sec. C:** Total Effective Grade = 4% + 4% = 8%

**Sec. D:** Total Effective Grade = 10% + 0% = 10%

**1. Estimate Payload:**

Est. load (LCM) × L.F. × Bank Density = payload  
24 LCM × 0.80 × 1770 kg/BCM = 34 000 kg payload

**2. Machine Weight:**

Empty Wt. — 46 475 kg or 46.48 metric tons  
Wt. of Load — 34 000 kg or 34 metric tons  
Total (GMW) — 80 475 kg or 80.48 metric tons

**3. Calculate Usable Pull (traction limitation):**

*Loaded:* (weight on driving wheels = 54%) (GMW)

Traction Factor × Wt. on driving wheels =  
0.50 × 80 475 kg × 54% = 21 728 kg

*Empty:* (weight on driving wheels = 69%) (GMW)

Traction Factor × Wt. on driving wheels =  
0.50 × 46 475 kg × 69% = 16 034 kg

**4. Derate for Altitude:**

Check power available at 2300 m from altitude deration table in the Tables Section.

631G — 100%      12H — 83%  
D9T — 100%      825G — 100%

Then adjust if necessary:

*Load Time* — controlled by D9T, at 100% power, no change.

*Travel, Maneuver and Spread time* — 631G, no change.

**5. Compare Total Resistance to Tractive Effort on haul:**

*Grade Resistance* —

GR = 10 kg/metric ton × tons × adverse grade  
in percent

Sec. C: = 10 kg/metric ton × 80.48 metric tons × 4%  
grade = 3219 kg

*Rolling Resistance* —

RR = RR Factor (kg/mton) × GMW (metric tons)

Sec. A: = 100 kg/metric ton × 80.48 metric tons  
= 8048 kg

Sec. B: = 40 kg/metric ton × 80.48 metric tons  
= 3219 kg

Sec. C: = 40 kg/metric ton × 80.48 metric tons  
= 3219 kg

Sec. D: = 100 kg/metric ton × 80.48 metric tons  
= 8048 kg

*Total Resistance* —

TR = RR + GR

Sec. A: = 8048 kg + 0 = 8048 kg

Sec. B: = 3219 kg + 0 = 3219 kg

Sec. C: = 3219 kg + 3219 kg = 6438 kg

Sec. D: = 8048 kg + 0 = 8048 kg

Check usable kilogram force against maximum kilogram force required to move the 631G.

Force usable ... 21 728 kg loaded

Force required ... 8048 kg maximum total resistance

Estimate travel time for haul from 631G (loaded) travel time curve; read travel time from distance and effective grade.

Travel time (from curves):

Sec. A: 0.60 min

Sec. B: 1.00

Sec. C: 1.20

Sec. D: 0.60

3.40 min

**NOTE:** This is an estimate only; it *does not account for all the acceleration and deceleration time*, therefore it is not as accurate as the information obtained from a computer program.

**6. Compare Total Resistance to Tractive Effort on return:**

*Grade Assistance* —

GA = 10 kg/mton × metric tons × negative grade  
in percent

Sec. C: = 10 kg/metric ton × 46.48 metric tons  
× 4% grade = 1859 kg

*Rolling Resistance —*

RR = RR Factor × Empty Wt.

- Sec. D: = 100 kg/metric ton × 46.48 metric tons  
= 4648 kg
- Sec. C: = 40 kg/metric ton × 46.48 metric tons  
= 1859 kg
- Sec. B: = 40 kg/metric ton × 46.48 metric tons  
= 1859 kg
- Sec. A: = 100 kg/metric ton × 46.48 metric tons  
= 4648 kg

*Total Resistance —*

TR = RR – GA

- Sec. D: = 4648 kg – 0 = 4648 kg
- Sec. C: = 1859 kg – 1859 kg = 0
- Sec. B: = 1859 kg – 0 = 1859 kg
- Sec. A: = 4648 kg – 0 = 4648 kg

Check usable kilogram force against maximum force required to move the 631G.

- Kilogram force usable ... 16 034 kg empty
- Kilogram force required ... 4645 kg

Estimate travel time for return from 631G empty travel time curve.

Travel time (from curves):

- Sec. A: 0.40 min
  - Sec. B: 0.55
  - Sec. C: 0.80
  - Sec. D: 0.40
- 
- 2.15 min

**7. Estimate Cycle Time:**

- Total Travel Time (Haul plus Return) = 5.55 min
- Adjusted for altitude: 100% × 5.55 min = 5.55 min
- Load Time = 0.7 min
- Maneuver and Spread Time = 0.7 min

---

- Total Cycle Time = 6.95 min

**8. Check pusher-scraper combinations:**

Pusher cycle time consists of load, boost, return and maneuver time. Where actual job data is not available, the following may be used.

- Boost time = 0.10 minute
- Return time = 40% of load time
- Maneuver time = 0.15 minute
- Pusher cycle time = 140% of load time + 0.25 minute
- Pusher cycle time = 140% of 0.7 min + 0.25 minute  
= 0.98 + 0.25 = 1.23 minute

Scraper cycle time divided by pusher cycle time indicates the number of scrapers which can be handled by each pusher.

$$\frac{6.95 \text{ min}}{1.23 \text{ min}} = 5.65$$

Each push tractor is capable of handling five plus scrapers. Therefore the two pushers can adequately serve the eleven scrapers.

**9. Estimate Production:**

- Cycles/hour = 60 min ÷ Total cycle time  
= 60 min/hr ÷ 6.95 min/cycle  
= 8.6 cycles/hr
- Estimated load = Heaped capacity × L.F.  
= 24 LCM × 0.80  
= 19.2 BCM
- Hourly unit production = Est. load × cycles/hr  
= 19.2 BCM × 8.6 cycles/hr  
= 165 BCM
- Adjusted production = Efficiency factor × hourly production  
= 0.83 (50 min hour) × 165 BCM  
= 137 BCM/hour
- Hourly fleet production = Unit production × No. of units  
= 137 BCM/hr × 11 units  
= 1507 BCM/hr

**10. Estimate Compaction:**

- Compaction requirement = S.F. × hourly fleet production  
= 0.85 × 1507 BCM/hr  
= 1280 CCM/hr

Compaction capability (given the following):

- Compacting width, 2.26 m (W)
- Average compacting speed, 9.6 km/h (S)
- Compacted lift thickness, 18 cm (L)
- No. of passes required, 3 (P)

825G production =

$$\begin{aligned} \text{CCY/hr} &= \frac{W \times S \times L \times 10}{P} \text{ (conversion factor)} \\ &= \frac{2.26 \times 9.6 \times 18 \times 10}{3} \\ &= 1302 \end{aligned}$$

Given the compaction requirement of 1280 CCM/h, the 825G is an adequate compactor match-up for the rest of the fleet. However, any change to job layout that would increase fleet production would upset this balance.



**SYSTEMS**

Caterpillar offers a variety of machines for different applications and jobs. Many of these separate machines function together in mining and earthmoving systems.

- Bulldozing with track-type tractors
- Load-and-Carry with wheel loaders
- Scrapers self-loading, elevator, auger, or push-pull configurations, or push-loaded by track-type tractors
- Articulated trucks loaded by excavators, track loaders or wheel loaders
- Off-highway trucks loaded by shovels, excavators or wheel loaders

**Haul System Selection:** In selecting a hauling system for a project, there may seem to be more than one “right” choice. Many systems may meet the distance, ground conditions, grade, material type, and production rate requirements. After considering all of the different factors, one hauling system usually provides better performance. This makes it critical for the dealer and customer to work together to get accurate information for their operation or project. Caterpillar is committed to providing the correct earthmoving system to match the customer’s specific needs.



**GENERAL LOADED HAUL DISTANCES FOR MOBILE SYSTEMS**

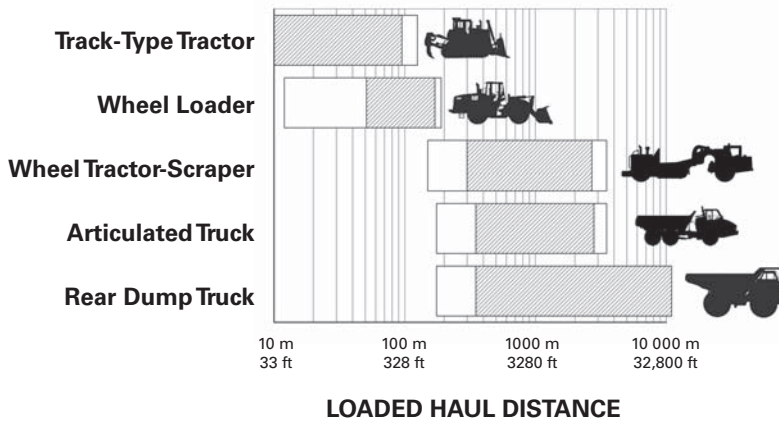

## **PRODUCTION ESTIMATING**

**Loading Match** — Loading tools have a production range that varies with material, bucket configuration, target size, operator skill and load area conditions. The loader/truck matches given in the following table are with the typical number of passes and production range.

Your Cat® dealer can provide advice and estimates based on your specific conditions.

### **Cat Earthmoving and Mining Systems Production/50 Min. Hr.**

Please refer to the individual machine section for production targets.

## **FUEL CONSUMPTION AND PRODUCTIVITY**

Fuel efficiency is the term used to relate fuel consumption and machine productivity. It is expressed in units of material moved per volume of fuel consumed. Common units are cubic meters or tonnes per liter of fuel (cubic yards or tons/gal). Determining fuel efficiency requires measuring both fuel consumption and production.

Measuring fuel consumption involves tapping into the vehicle's fuel supply system — without contaminating the fuel. The amount of fuel consumed during operation is then measured on a weight or volumetric basis and correlated with the amount of work the machine has done. Cat machines equipped with VIMS™ system can record fuel consumed with relative accuracy, given the engine is performing close to specifications.

### **Cat Aggregate Systems Production/50 Min. Hr.**

Please refer to the individual machine section for production targets.

**FORMULAS AND RULES OF THUMB**

$$\text{Production, hourly} = \text{Load (BCM)/cycle} \times \text{cycles/hr}$$

$$= \text{Load (BCY)/cycle} \times \text{cycles/hr}$$

$$\text{Load Factor (L.F.)} = \frac{100\%}{100\% + \% \text{ swell}}$$

$$\text{Load (bank measure)} = \text{Loose cubic meters (LCM)} \times \text{L.F.}$$

$$= \text{Loose cubic yards (LCY)} \times \text{L.F.}$$

$$\text{Shrinkage Factor (S.F.)} = \frac{\text{Compacted cubic meters (or yards)}}{\text{Bank cubic meters (or yards)}}$$

$$\text{Density} = \text{Weight/Unit Volume}$$

$$\text{Load (bank measure)} = \frac{\text{Weight of load}}{\text{Bank density}}$$

$$\text{Rolling Resistance Factor}$$

$$= 20 \text{ kg/t} + (6 \text{ kg/t/cm} \times \text{cm})$$

$$= 40 \text{ lb/ton} + (30 \text{ lb/ton/inch} \times \text{inches})$$

$$\text{Rolling Resistance}$$

$$= \text{RR Factor (kg/t)} \times \text{GMW (tons)}$$

$$= \text{RR Factor (lb/ton)} \times \text{GMW (tons)}$$

$$\text{Rolling Resistance (general estimation)}$$

$$= 2\% \text{ of GMW} + 0.6\% \text{ of GMW per cm tire penetration}$$

$$= 2\% \text{ of GMW} + 1.5\% \text{ of GMW per inch tire penetration}$$

$$\% \text{ Grade} = \frac{\text{vertical change in elevation (rise)}}{\text{corresponding horizontal distance (run)}}$$

$$\text{Grade Resistance Factor} = 10 \text{ kg/m ton} \times \% \text{ grade}$$

$$= 20 \text{ lb/ton} \times \% \text{ grade}$$

$$\text{Grade Resistance} = \text{GR Factor (kg/t)} \times \text{GMW (tons)}$$

$$= \text{GR Factor (lb/ton)} \times \text{GMW (tons)}$$

$$\text{Grade Resistance} = 1\% \text{ of GMW} \times \% \text{ grade}$$

*Total Resistance*

$$= \text{Rolling Resistance (kg or lb)} + \text{Grade Resistance (kg or lb)}$$

$$\text{Total Effective Grade (\%)} = \text{RR (\%)} + \text{GR (\%)}$$

*Usable pull (traction limitation)*

$$= \text{Coeff. of traction} \times \text{weight on drivers}$$

$$= \text{Coeff. of traction} \times (\text{Total weight} \times \% \text{ on drivers})$$

$$\text{Pull required} = \text{Rolling Resistance} + \text{Grade Resistance}$$

$$= \text{Total Resistance}$$

$$\text{Total Cycle Time} = \text{Fixed time} + \text{Variable time}$$

*Fixed time:* See respective machine production section.

$$\text{Variable time} = \text{Total haul time} + \text{Total return time}$$

$$\text{Travel Time} = \frac{\text{Distance (m)}}{\text{Speed (m/min)}}$$

$$= \frac{\text{Distance (ft)}}{\text{Speed (fpm)}}$$

$$\text{Cycles per hour} = \frac{60 \text{ min/hr}}{\text{Total cycle time (min/cycle)}}$$

$$\text{Adjusted production} = \text{Hourly production} \times \text{Efficiency factor}$$

$$\text{No. of units required} = \frac{\text{Hourly production required}}{\text{Unit hourly production}}$$

$$\text{No. of scrapers a pusher will load} = \frac{\text{Scraper cycle time}}{\text{Pusher cycle time}}$$

$$\text{Pusher cycle time (min)} = 1.40 \text{ Load time (min)} + 0.25 \text{ min}$$

$$\text{Grade Horsepower} = \frac{\text{GMW (kg)} \times \text{Total Effective Grade} \times \text{Speed (km/h)}}{273.75}$$

$$= \frac{\text{GMW (lb)} \times \text{Total Effective Grade} \times \text{Speed (mph)}}{375}$$





# STOCKPILE COAL HANDLING

## CONTENTS

Introduction . . . . .	29-1
Machine Selection . . . . .	29-1
How to Equip . . . . .	29-2
Production Factors . . . . .	29-2
Estimating Hourly Production . . . . .	29-3
Track-Type Tractors . . . . .	29-4
Wheel Dozers . . . . .	29-5
Wheel Loaders . . . . .	29-7
Wheel Tractor-Scrapers . . . . .	29-8
Example Problem . . . . .	29-9

## INTRODUCTION

Efficient methods have been developed for handling and storing coal with mobile equipment. Generally, a power plant or other industrial facility which uses coal, meets its daily requirements with incoming coal shipments and will maintain an emergency stockpile or deadpile. The deadpile is designed to meet the burn requirements during any interruption of coal shipments. Interruptions may include inclement weather, carrier strikes, scheduling problems, etc.

The deadpile will contain approximately a 90 day supply of coal and is constructed by thoroughly compacting lifts, or layers, of coal approximately 15 cm (6 in) thick. Thorough compaction of the entire stockpile, including the sides, eliminates air spaces, reducing the possibility of spontaneous combustion.

Reclaiming the deadpiled coal is critical when incoming shipments are not able to satisfy the burn requirements. Four basic types of mobile equipment are available for stockpiling and reclaiming coal — track-type tractors, wheel dozers, wheel loaders, and wheel tractor-scrappers. Each type has its own specific advantages. The equipment selected must be able to meet the maximum hourly burn rate.

## MACHINE SELECTION

### Track-Type Tractors

Track-type tractors continue to be the most widely used machines for coal handling operations. Equipped with a U-shaped coal dozer, they are suitable for meeting high production requirements over dozing distances of

less than 152 m (500 ft). Their tractive capabilities and gradeability permit them to operate on the sides of the stockpile and surge pile which often prove inaccessible to other types of equipment. They can also remove snow and frost penetrated coal from the stockpile surface so that rubber-tired equipment can work efficiently.

### Wheel Dozers

These machines, with their long wheel base, low center of gravity, and articulated design, offer good stability and maneuverability. They have the ability to travel at a higher speed than the track-type tractor, moving easily from one area of operation to another, and provide greater compactive effort with fewer passes. They are capable of performing some utility functions. However, their coefficient of traction is less than that of track-type tractors. The most efficient dozing distance for the wheel dozers is usually less than 152 m (500 ft).

Coal scoop attachments are available for wheel dozers and can provide improved production due to the higher volume of the scoop.

### Wheel Loaders

As dozing and hauling distances increase, wheel loaders are able to effectively move coal in load-and-carry operations. Since coal is a relatively light material, the loaders should be equipped with larger buckets sized for coal density. Versatility and mobility allow them to perform a variety of tasks, both on and off the stockpile. They can load trucks or railcars, dig out bottom ash and boiler slag from the ash storage areas, and move railcars within the vicinity of the power plant. Generally wheel loaders are more efficient than track or wheel dozers at distances of 122 m (400 ft) or more.

### Coal Bowl Wheel Tractor-Scrapers

Coal Bowl Wheel Tractor-Scrapers are typically used for building and maintaining coal stockpiles and hauling coal to the supply system at coal power plants. The self-loading capability, large capacity, coal pile compaction, and haul speed of Coal Bowl Wheel Tractor-Scrapers make them the tool of choice for moving coal both short and long distances. Coal Bowl Wheel Tractor-Scrapers are available in the 637K and 657G twin engine models. Please reference section 24 of this handbook for more information on Coal Bowl Wheel Tractor-Scrapers.

**HOWTO EQUIP**

**Counterweighting**

While larger blades or buckets allow for greater production, counterweighting is often necessary to improve the machine’s balance and handling capability. For track-type tractors, a rear counterweight is recommended. Wheel machines use various methods to add weight. For example, wheel dozers use front counterweights, and wheel machines often use tire ballast. Below is a weight comparison of the Cat® standard U-Blade to the Coal U-Blade, along with the recommended counterweight for D11T, D10T2, D9T, D8T, and 834K.

**COAL STOCKPILE BLADE WEIGHT COMPARISON/  
COUNTERWEIGHTING**

Model	U-Blade		Coal U-Blade/ Scoop		Counterweight	
	kg	lb	kg	lb	kg	lb
D11T	12 880	<b>28,396</b>	11 475	<b>25,298</b>	4989	<b>11,000</b>
D10T2	7918	<b>17,456</b>	7100	<b>15,653</b>	2928	<b>6456</b>
D9T	5634	<b>12,421</b>	4650	<b>10,252</b>	3142	<b>6926</b>
D8T	2825	<b>6228</b>	3200	<b>7050</b>	2749	<b>6060</b>
834K	2994	<b>6600</b>	3630	<b>8000</b>	75% CaCl <sub>2</sub> in all tires —	
*834K with Scoop			8700	<b>19,180</b>	5360	<b>11,816</b>

Weights include blade or scoop only. The change in machine weight is determined by adding or subtracting the difference between the two blades. Counterweight or ballast may also need to be considered.

**Track Shoe Width**

Track shoes are an important consideration since shoe width determines tractive capability and compaction. Depending on the coal being stockpiled, the utility company will often have a strong preference concerning track shoe width. Basically, utilities stockpiling low rank or sub-bituminous rank lignite coal usually prefer the standard shoe width for maximum compactive effort to reduce the possibility of spontaneous combustion.

Utilities burning medium or high rank bituminous coals are not as concerned with spontaneous combustion and sometimes prefer a wider shoe that allows increased tractive capability on loose or less densely compacted coal stockpiles.

**Tires**

Many utility companies have established a tire preference for wheel machines. Normally a radial tire allows for the maximum tire print in the stockpile surface providing the best traction.

**Other**

The 834K’s performance may be improved in the varying underfoot conditions of a coal stockpile with the use of a Detroit NoSPIN differential. This differential provides added tractive capability on all coal piles, particularly loose coal. Use of a NoSPIN differential should carefully be evaluated. The NoSPIN differential will also increase tire wear and decrease axle component life in applications with good traction.

**PRODUCTION FACTORS**

1. *The effect of grade* — dozer production will increase 3% for each 1% of favorable grade and decrease 2% for each 1% of adverse grade up to grades of 10%. The graph below exemplifies this point.

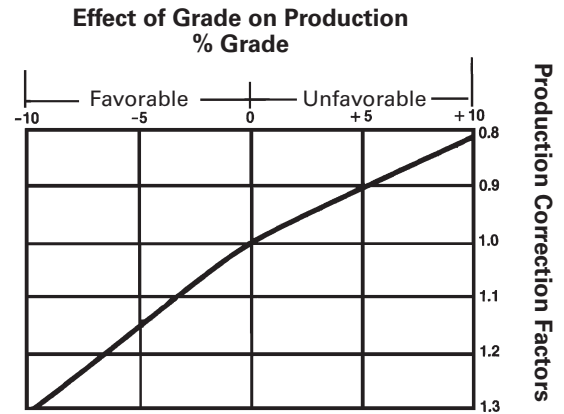

As a rule of thumb, track-type tractors can negotiate grades of about 60% in loose coal. Wheel dozers can negotiate grades up to 25% on fairly well compacted coal.

2. *Slot dozing*, which consists of dozing repeatedly in the same tracks, will increase production. The deeper the slot, the greater the increase in production. Obviously this will disrupt the surface of the pile; however it does provide maximum production.

Slot Condition	Slot Depth	Increase in Production
Slight	60 cm ~ <b>2 ft</b>	10%
Consistent	60 cm-1.5 m ~ <b>2-5 ft</b>	25%
Very Consistent	Over 1.5 m ~ <b>Over 5 ft</b>	30% +

3. *Relative traction* — machines will provide greater tractive effort as the compaction beneath them increases.

Condition	Machine	Coefficient of Traction
Well Compacted Coal	Track-type	*0.75-0.80
	Wheel	0.40-0.50
Loose Coal	Track-type	*0.60
	Wheel	0.30-0.40

\*D11T, D10T2, D9T and D8T will often achieve a higher coefficient of traction due to their suspended undercarriage.

4. *Rolling Resistance* of rubber tired equipment will decrease as the compaction of the coal beneath the machines increases. Here are total rolling resistances on various surfaces.

	kg/Metric Ton	lb/U.S. Ton
● Main travel area from loading area to stockpile traveled and maintained.	29	<b>65</b>
● Travel over the compacted deadpile.	36	<b>80</b>
● Travel over thin lifts of uncompacted coal on the deadpile.	54	<b>120</b>
● Travel on loose piles under stacking conveyor or on a windrow.	90-136	<b>200-300</b>

5. *The degree of compaction required* — for medium and high rank bituminous coal, track-type tractors will normally provide ample compaction to prevent fires. For low rank coals, such as sub-bituminous and lignite, rubber tired machines, pneumatic compactors or sealing may be required to prevent fires. The following table illustrates the compaction that is possible if the coal is spread in thin lifts and the machine makes a sufficient number of passes over the entire lift surface.

Machine	kg/m <sup>3</sup>	lb/ft <sup>3</sup>	lb/yd <sup>3</sup>
Track-Type Tractors	960-1160	<b>60-72</b>	<b>1620-1950</b>
Wheel Dozers	1040-1200	<b>65-75</b>	<b>1750-2030</b>
Wheel Loaders	1040-1250	<b>65-78</b>	<b>1750-2110</b>
Wheel Tractor-Scrapers	1100-1280	<b>68-80</b>	<b>1840-2160</b>

## ESTIMATING HOURLY PRODUCTION

The following graphs may be used for estimating the hourly production of machines handling mixed bituminous coal. The graphs are based on 100% machine efficiency under normal job conditions and average operator; they do not take into account adverse grades, downtime, wait time, poor traction, etc. These production estimates should be evaluated in light of individual job conditions and efficiency. Moreover, a job efficiency correction factor should be applied to the production estimate shown when using these graphs.

To estimate travel times for a specific machine refer to the performance graphs or charts in the appropriate model section of this book.

**NOTE:** Capacities and production curves on the next pages are based on bituminous coal with a density of 890 kg/m<sup>3</sup> or 1500 lb/yd<sup>3</sup> or 55 lb/ft<sup>3</sup>. For sub-bituminous coal with a density of 800 kg/m<sup>3</sup> or 1350 lb/yd<sup>3</sup> or 50 lb/ft<sup>3</sup> multiply tonnage figure by 0.90. For lignite with an average density of 710 kg/m<sup>3</sup> or 1200 lb/yd<sup>3</sup> or 45 lb/ft<sup>3</sup> multiply tonnage figure by 0.80.

**Track-Type Tractors Estimated Production with U-Blade (Coal Dozer)**

**Factors:**

- Mixed Bituminous Coal
- Storage and Reclamation
- 0% Grade
- 0.80 Coefficient of Traction

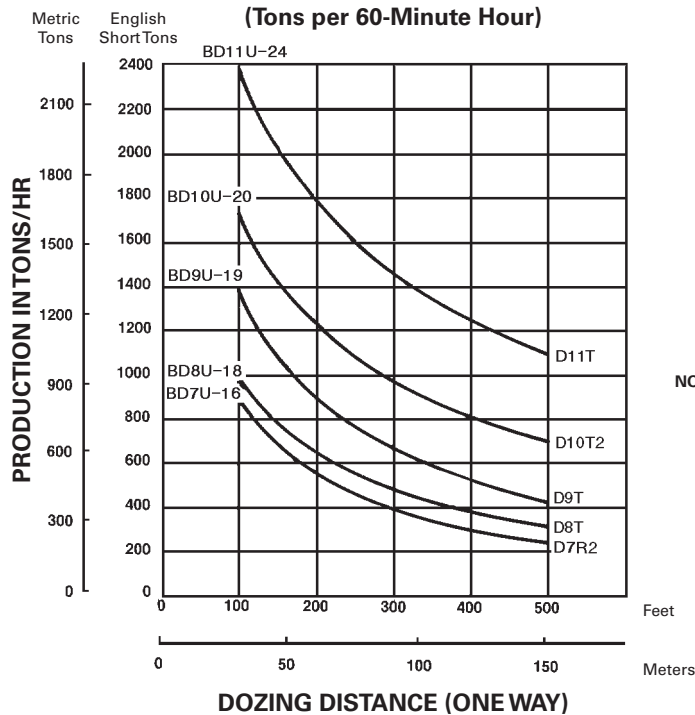

**NOTE:** This chart is based on numerous field studies made under varying job conditions. Refer to correction factors following these charts.

Tractor	U-Blade			Blade Capacities			
	Model	m	ft	Metric tons	U.S. tons	m <sup>3</sup>	yd <sup>3</sup>
D11T	BD11U-24	7.32	24'	66.7	73.5	74.9	98.0
D10T2	BD10U-20	6.10	20'	40.85	45.0	45.9	60.0
D9T	BD9U-19	5.79	19'	32.6	35.9	37.0	48.0
D8T	BD8U-18	5.49	18'	19.0	21.0	21.4	28.0
D7R2	BD7U-16	4.88	16'	14.28	15.75	16.05	21.0
D6R	BD6U	4.27	14'	8.84	9.75	9.9	13.0

Refer to Track-Type Tractor/Bulldozer section for additional special attachment specifications.

**Wheel Dozers Estimated Production with U-Blade (Coal Dozer)**

**NOTE:** This chart is based on numerous field studies made under varying job conditions. Refer to correction factors following these charts.

**Factors:**

- Mixed Bituminous Coal
- Storage and Reclamation
- 0% Grade
- 0.80 Coefficient of Traction

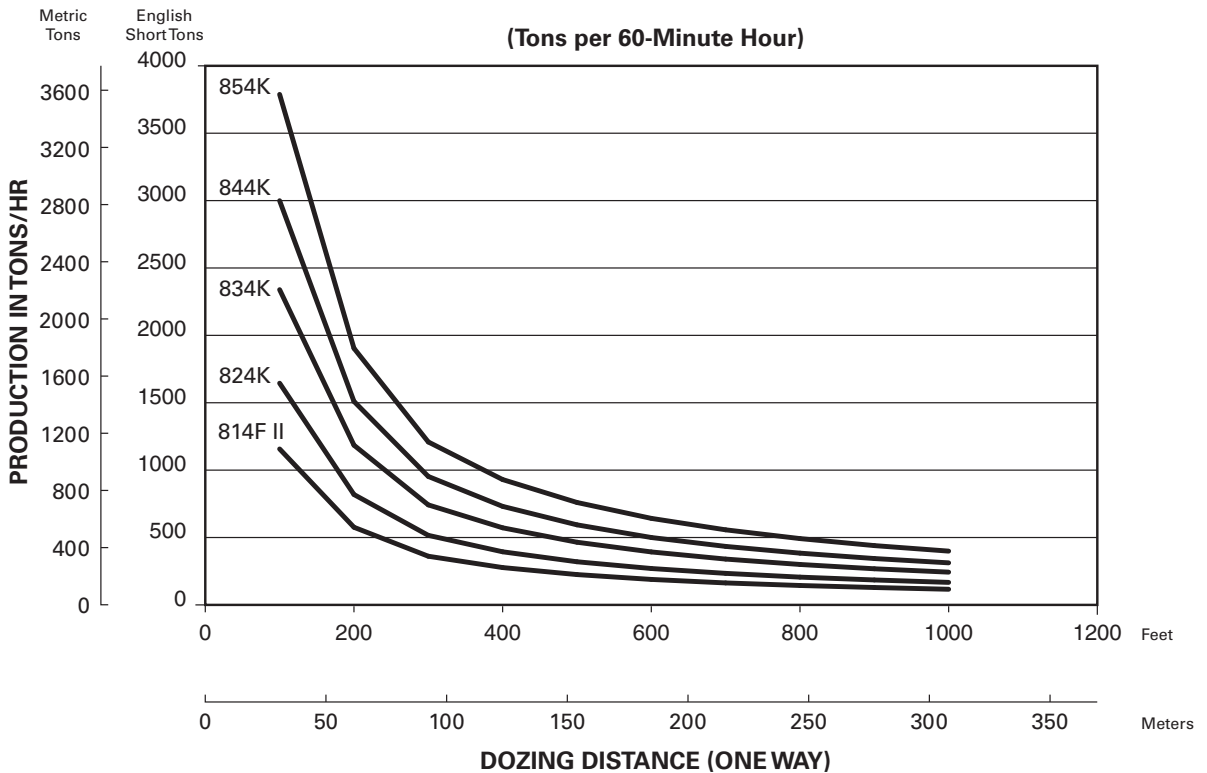

29

Tractor	U-Blade			Blade Capacities			
	Model	m	ft	Metric tons	U.S. tons	m <sup>3</sup>	yd <sup>3</sup>
854K	153-2113	7.20	23'8"	39.8	43.65	44.7	58.2
844K	153-2111	5.84	19'2"	27.3	30.20	30.7	40.2
834K	376-3845	6.17	20'3"	19.8	21.80	22.2	29.0
824K	BD824U-15	4.79	15'7"	14.2	15.70	16.2	21.1
814F II	BD814U-14	4.32	14'2"	9.4	10.30	11.0	14.0

**NOTE:** Blade capacities in tons figured using weight of coal at 890 kg/m<sup>3</sup> (1500 lb/yd<sup>3</sup>).

Refer to Track-Type Tractor/Bulldozer section for additional special attachment specifications.

**Wheel Dozers Estimated Production with Coal Scoop**

**Factors:**

- **Mixed Bituminous Coal**
- **Storage and Reclamation**
- **0% Grade**
- **0.80 Coefficient of Traction**

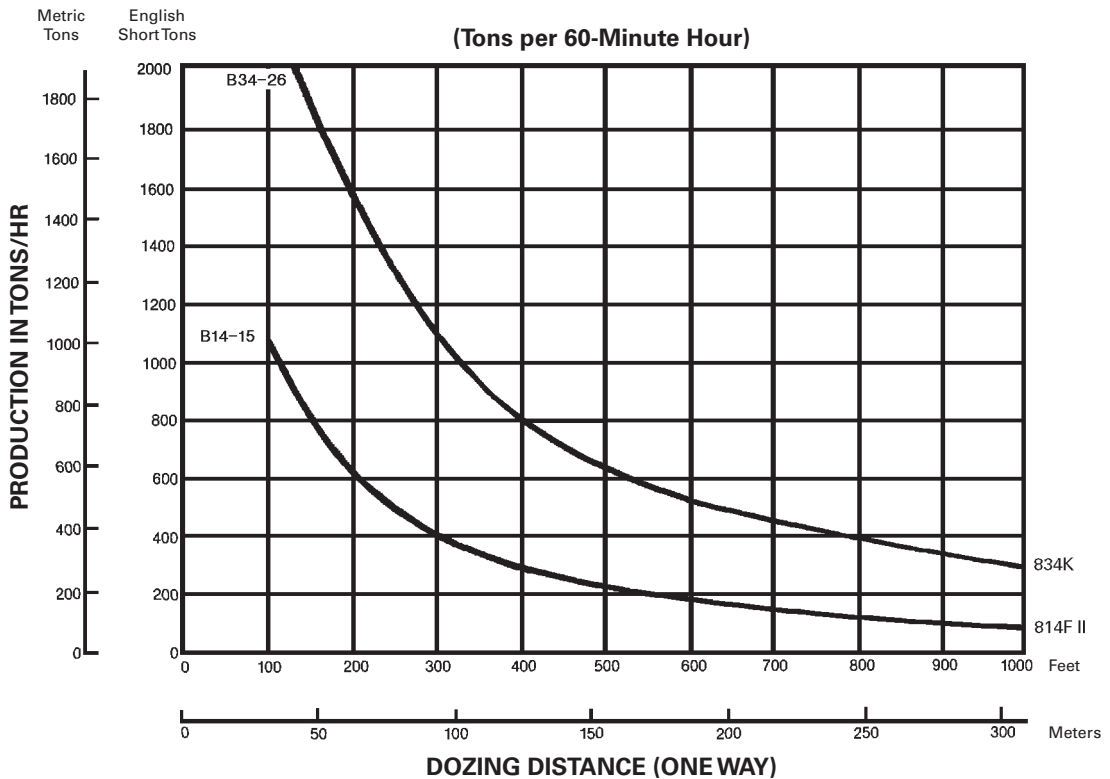

Tractor	Coal Scoop			Scoop Capacities (Lift and Carry)				Doze Capacities			
	Model	m	ft	Metric tons	U.S. tons	m <sup>3</sup>	yd <sup>3</sup>	Metric tons	U.S. tons	m <sup>3</sup>	yd <sup>3</sup>
834K	220-3648	4.9	15'11"	19.7	21.8	22.9	30	37.8	41.2	44.2	57.8
814F II	B14-15	3.7	12'3"	8.2	9.0	11.5	15	16.3	18.0	19.1	25

Refer to Track-Type Tractor/Bulldozer section for additional special attachment specifications.

**Wheel Loaders Estimated Production  
with Coal Bucket**

**Factors:**

- Mixed Bituminous Coal
- Storage and Reclamation
- 0% Grade
- 0.80 Coefficient of Traction

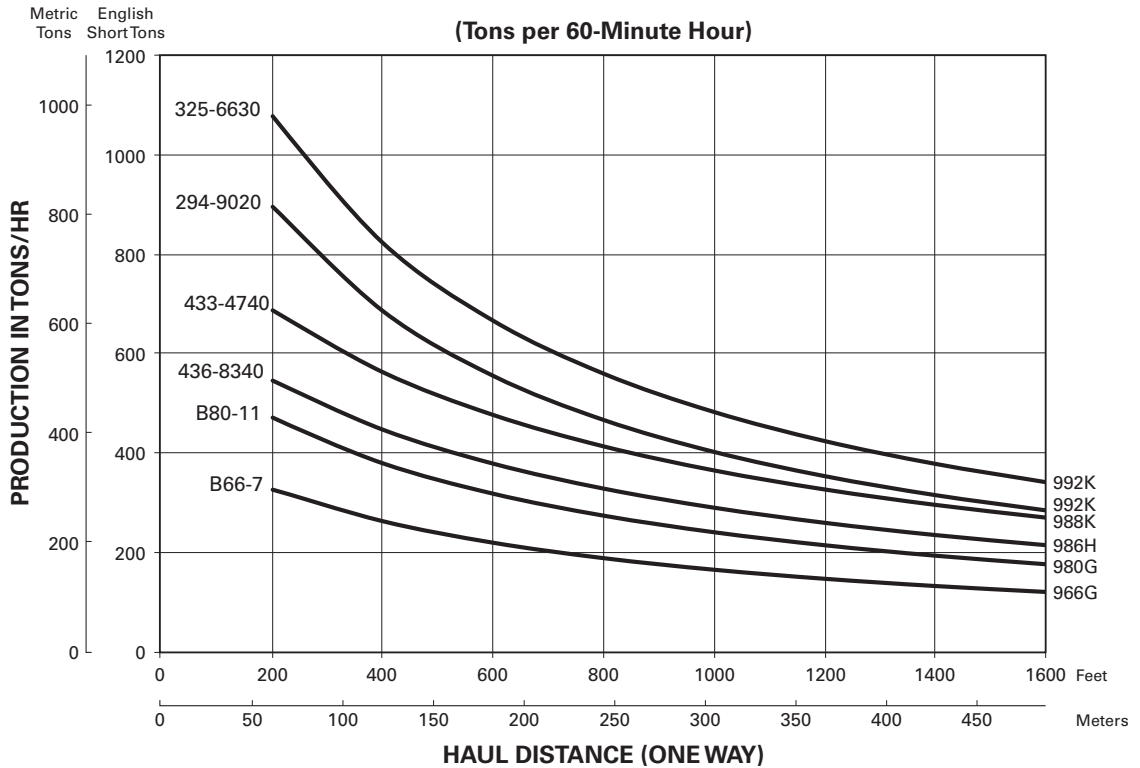

Loader	Coal Bucket	Bucket Capacities			
	Model	Metric tons	U.S. tons	m <sup>3</sup>	yd <sup>3</sup>
992K	294-9020	17.0	18.8	19.1	25.0
992K	325-6630	20.4	22.5	22.9	30.0
988K	433-4740	11.6	12.8	13.0	17.0
986H	436-8340	9.2	10.1	10.3	13.5
980G	B80-11	7.3	8.1	8.2	10.8
966G	B66-7	4.9	5.4	5.5	7.3

**NOTE:** Bucket capacities include bottom cutting edge. Figured using weight of coal at 890 kg/m<sup>3</sup> (1500 lb/yd<sup>3</sup>).



Wheel Tractor-Scrapers Estimated Production

Factors:

- Mixed Bituminous Coal
- Storage and Reclamation
- 0% Grade
- 0.50 Coefficient of Traction

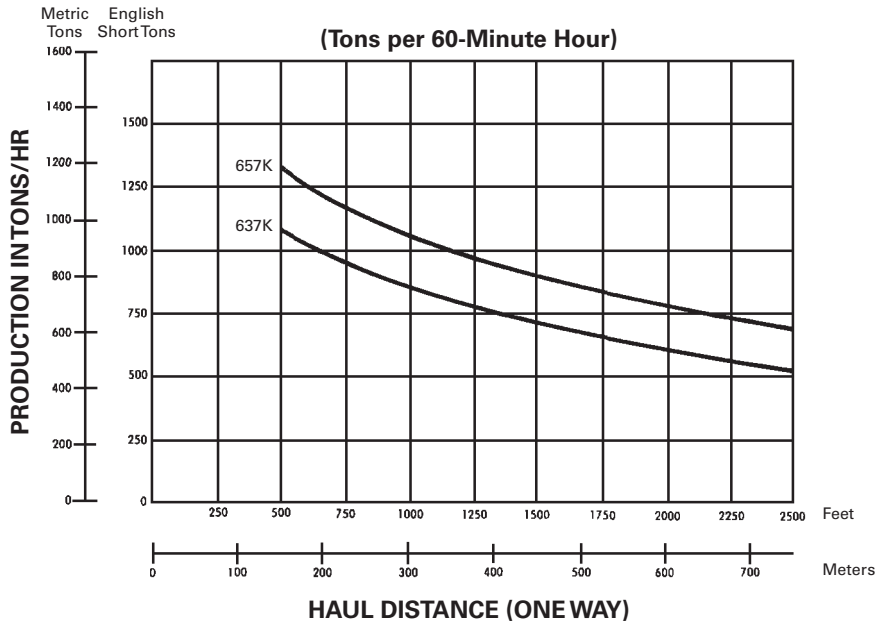

Coal Scraper	Bowl Capacities					
	Metric tons	U.S. tons	Struck		Heaped	
			m <sup>3</sup>	yd <sup>3</sup>	m <sup>3</sup>	yd <sup>3</sup>
657K	49.9	55	45	59	56	73
637K	34.5	38	31	41	38	50

Average fixed time to load, maneuver and dump:  
 657K – 1.12 min.  
 637K – 1.10 min.

**NOTE:**

- The 657K Coal Scraper is 1072 mm (42.2") longer, the bowl sides are 1010 mm (39.8") taller, the apron is 677 mm (26.7") taller, and the ejector is 944 mm (37.2") taller than its earthmoving counterpart.
- The 637K Coal Scraper is 736 mm (29.0") longer, the bowl sides are 476 mm (18.7") taller, and the apron is 499 mm (19.6") taller than its earthmoving counterpart.
- The rimpull, travel times, and retarder performance for the coal scrapers are the same as for the standard machines. See Wheel Tractor-Scrapers section for charts and graphs.

Example Problem

A coal-fired utility company has a coal requirement of approximately 315 metric tons (350 tons) per hour. Specify the coal handling machine that will satisfy this demand.

Conditions:

- Lignite Coal 710 kg/m<sup>3</sup> (1200 lb/yd<sup>3</sup>)
- 90 m (300 ft) push distance
- 5% adverse grade
- 50 minute hour operation efficiency

Solution:

Calculate the D9T's production equipped with the BD9U-19 Coal U-Blade by using the D9T production curve. Start at 90 m (300 ft) and read up to the D9T production line, then over to the left to determine its maximum hourly production of 612 metric tons (675 tons).

Since the graphs are based on a 890 kg/m<sup>3</sup> (1500 lb/yd<sup>3</sup>) coal density, this production figure has to be adjusted to reflect lignite coal:

Coal density correction factor =  $710/890$  (1200/1500) = 0.8.

Obtain the production correction factor for the 5% adverse grade from the chart: 0.9.

The correction factor for the 50 minute hour is  $50/60 = 0.83$ .

Now calculate the adjusted D9T hourly production using the correction factors:

Metric  $612 \times 0.8 \times 0.9 \times 0.83 = 366$  tons/hour

English  $675 \times 0.8 \times 0.9 \times 0.83 = 403$  tons/hour

The D9T falls in the required production range. For short periods of peak power capacity, production could be increased by slot dozing.

Production for the D10T2, 824K and 834K can be calculated using the same method.

**D10T2**

Metric  $850 \times 0.8 \times 0.9 \times 0.83 = 508$  tons/hour

English  $935 \times 0.8 \times 0.9 \times 0.83 = 559$  tons/hour

**824K**

Metric  $400 \times 0.8 \times 0.9 \times 0.83 = 239$  tons/hour

English  $440 \times 0.8 \times 0.9 \times 0.83 = 263$  tons/hour

**834K**

Metric  $689 \times 0.8 \times 0.9 \times 0.83 = 412$  tons/hour

English  $760 \times 0.8 \times 0.9 \times 0.83 = 454$  tons/hour

Therefore, the D9T or 834K could most economically satisfy the production requirements.



# TABLES

## CONTENTS

Swell — Voids — Load Factors . . . . .	30-1
Bucket Fill Factors . . . . .	30-2
Angle of Repose of Various Materials . . . . .	30-2
Typical Rolling Resistance Factors . . . . .	30-2
Round Reinforced Concrete Pipe	
Approximate Weight per Foot . . . . .	30-3
Coefficient of Traction Factors . . . . .	30-3
Speed Conversion . . . . .	30-4
Bearing Powers . . . . .	30-4
Agricultural Commodities Conversion Factors . .	30-4
Curve Superelevation in Percent Grade,	
to Provide No Lateral Tire Force . . . . .	30-5
Maximum Speed on Curves for Various	
Superelevation Grades with a 0.20 Lateral	
Coefficient of Traction . . . . .	30-5
Weight of Materials . . . . .	30-6
Altitude Deration . . . . .	30-7
Grade Comparison Chart	
Degrees — Percent — Slope . . . . .	30-17
Grade in Degrees and Percents . . . . .	30-17
Conversion Factors . . . . .	30-18
Metric Unit Equivalents . . . . .	30-19
English Unit Equivalents . . . . .	30-19
Power Unit Equivalents . . . . .	30-19
Machine/Engine Cross Reference . . . . .	30-20
Engine/Machine Cross Reference . . . . .	30-24

## SWELL — VOIDS — LOAD FACTORS

SWELL (%)	VOIDS (%)	LOAD FACTOR
5	4.8	0.952
10	9.1	0.909
15	13.0	0.870
20	16.7	0.833
25	20.0	0.800
30	23.1	0.769
35	25.9	0.741
40	28.6	0.714
45	31.0	0.690
50	33.3	0.667
55	35.5	0.645
60	37.5	0.625
65	39.4	0.606
70	41.2	0.588
75	42.9	0.571
80	44.4	0.556
85	45.9	0.541
90	47.4	0.526
95	48.7	0.513
100	50.0	0.500

Throughout this document, references to Tier 4 Interim/Stage IIIB/Japan 2011 (Tier 4 Interim) include U.S. EPA Tier 4 Interim, EU Stage IIIB, and Japan 2011 (Tier 4 Interim) equivalent emission standards. References to Tier 4 Final/Stage IV/Japan 2014 (Tier 4 Final) include U.S. EPA Tier 4 Final, EU Stage IV, and Japan 2014 (Tier 4 Final) emission standards.

Throughout this document, references to Tier 1/Stage I include U.S. EPA Tier 1 and EU Stage I equivalent emission standards. References to Tier 2/Stage II/Japan 2001 (Tier 2) equivalent include U.S. EPA Tier 2, EU Stage II, and Japan 2001 (Tier 2) equivalent emission standards. References to Tier 3/Stage IIIA/Japan 2006 (Tier 3) equivalent include U.S. EPA Tier 3, EU Stage IIIA, and Japan 2006 (Tier 3) equivalent emission standards.

# Tables

## BUCKET FILL FACTORS

Loose Material	Fill Factor
Mixed Moist Aggregates	95-100%
Uniform Aggregates up to 3 mm (1/8")	95-100
3 mm-9 mm (1/8"-3/8")	90-95
12 mm-20 mm (1/2"-3/4")	85-90
24 mm (1") and over	85-90
<b>Blasted Rock</b>	
Well Blasted	80-95%
Average Blasted	75-90
Poorly Blasted	60-75
<b>Other</b>	
Rock Dirt Mixtures	100-120%
Moist Loam	100-110
Soil, Boulders, Roots	80-100
Cemented Materials	85-95

**NOTE:** Loader bucket fill factors are affected by bucket penetration, breakout force, rack back angle, bucket profile and ground engaging tools such as bucket teeth or bolt-on replaceable cutting edges.

**NOTE:** For bucket fill factors for hydraulic excavators, see bucket payloads in the hydraulic excavator section.

**NOTE:** Above values are not valid for Hydraulic Mining Shovels.

## ANGLE OF REPOSE OF VARIOUS MATERIALS

MATERIAL	ANGLE BETWEEN HORIZONTAL AND SLOPE OF HEAPED PILE	
	Ratio	Degrees
Coal, industrial . . . . .	1.4:1—1.3:1	35-38
Common earth, Dry . . . . .	2.8:1—1.0:1	20-45
Moist . . . . .	2.1:1—1.0:1	25-45
Wet . . . . .	2.1:1—1.7:1	25-30
Gravel, Round to angular . . . . .	1.7:1—0.9:1	30-50
Sand & clay . . . . .	2.8:1—1.4:1	20-35
Sand, Dry . . . . .	2.8:1—1.7:1	20-30
Moist . . . . .	1.8:1—1.0:1	30-45
Wet . . . . .	2.8:1—1.0:1	20-45

## TYPICAL ROLLING RESISTANCE FACTORS

Various tire sizes and inflation pressures will greatly reduce or increase the rolling resistance. The values in this table are approximate, particularly for the track and track + tire machines. These values can be used for estimating purposes when specific performance information on particular equipment and given soil conditions is not available. See Mining and Earthmoving Section for more detail.

UNDERFOOTING	ROLLING RESISTANCE, PERCENT*			
	Tires		Track	Track
	Bias	Radial	**	+Tires
A very hard, smooth roadway, concrete, cold asphalt or dirt surface, no penetration or flexing. . .	1.5%*	1.2%	0%	1.0%
A hard, smooth, stabilized surfaced roadway without penetration under load, watered, maintained. . . . .	2.0%	1.7%	0%	1.2%
A firm, smooth, rolling roadway with dirt or light surfacing, flexing slightly under load or undulating, maintained fairly regularly, watered . . . . .	3.0%	2.5%	0%	1.8%
A dirt roadway, rutted or flexing under load, little maintenance, no water, 25 mm (1") tire penetration or flexing. . . . .	4.0%	4.0%	0%	2.4%
A dirt roadway, rutted or flexing under load, little maintenance, no water, 50 mm (2") tire penetration or flexing. . . . .	5.0%	5.0%	0%	3.0%
Rutted dirt roadway, soft under travel, no maintenance, no stabilization, 100 mm (4") tire penetration or flexing. . . . .	8.0%	8.0%	0%	4.8%
Loose sand or gravel . . . . .	10.0%	10.0%	2%	7.0%
Rutted dirt roadway, soft under travel, no maintenance, no stabilization, 200 mm (8") tire penetration and flexing . . . . .	14.0%	14.0%	5%	10.0%
Very soft, muddy, rutted roadway, 300 mm (12") tire penetration, no flexing . . . . .	20.0%	20.0%	8%	15.0%

\*Percent of combined machine weight.

\*\*Assumes drag load has been subtracted to give Drawbar Pull for good to moderate conditions. Some resistance added for very soft conditions.

**ROUND REINFORCED CONCRETE PIPE  
APPROXIMATE WEIGHT PER FOOT**

INSIDE DIAMETER		WEIGHT PER FT.	
mm	ft/in	kg	lb
305	12"	42	93
380	15"	58	127
460	18"	76	168
530	1'9"	97	214
610	2'0"	120	265
685	2'3"	146	322
760	2'6"	174	384
840	2'9"	205	452
915	3'0"	238	524
1070	3'6"	311	686
1220	4'0"	393	867
1370	4'6"	485	1069
1525	5'0"	588	1295
1675	5'6"	699	1542
1830	6'0"	821	1811
1980	6'6"	952	2100
2135	7'0"	1093	2409
2285	7'6"	1242	2740
2440	8'0"	1402	3090
2590	8'6"	1578	3480
2740	9'0"	1753	3865

NOTE: Table courtesy of American Concrete Pipe Assn.

**COEFFICIENT OF TRACTION FACTORS**

MATERIAL	TRACTION FACTORS	
	Rubber Tires	Tracks
Concrete . . . . .	0.90	0.45
Clay loam, dry . . . . .	0.55	0.90
Clay loam, wet . . . . .	0.45	0.70
Rutted clay loam . . . . .	0.40	0.70
Dry sand . . . . .	0.20	0.30
Wet sand . . . . .	0.40	0.50
Quarry pit . . . . .	0.65	0.55
Gravel road (loose not hard)	0.36	0.50
Packed snow . . . . .	0.20	0.27
Ice . . . . .	0.12	0.12
Semi-skeleton shoes		
Firm earth . . . . .	0.55	0.90
Loose earth . . . . .	0.45	0.60
Coal, stockpiled . . . . .	0.45	0.60

NOTE: The elevated sprocket design Track-Type Tractors (D11T, D10T2, D9T, D9R, D8T, and D8R), with their suspended undercarriage, provide up to 15% more efficient tractive effort than rigid tracked Track-Type Tractors.

# Tables

## SPEED CONVERSION

km/h Equivalents in m/min				MPH Equivalents in FPM			
km/h	m/min	km/h	m/min	mph	fpm	mph	fpm
1	16.7	21	350.0	1	88	21	1848
2	33.3	22	366.7	2	176	22	1936
3	50.0	23	383.3	3	264	23	2024
4	66.7	24	400.0	4	352	24	2112
5	83.3	25	416.7	5	440	25	2200
6	100.0	26	433.3	6	528	26	2288
7	116.7	27	450.0	7	616	27	2376
8	133.3	28	466.7	8	704	28	2464
9	150.0	29	483.3	9	792	29	2552
10	166.7	30	500.0	10	880	30	2640
11	183.3	31	516.7	11	968	31	2728
12	200.0	32	533.3	12	1056	32	2816
13	216.7	33	550.0	13	1144	33	2904
14	233.3	34	566.7	14	1232	34	2992
15	250.0	35	583.3	15	1320	35	3080
16	266.7	36	600.0	16	1408	36	3168
17	283.3	37	616.7	17	1496	37	3256
18	300.0	38	633.3	18	1584	38	3344
19	316.7	39	650.0	19	1672	39	3432
20	333.3	40	666.7	20	1760	40	3520

**NOTE:** Since 1 km/h equals 16.7 m/min (1000 ÷ 60), to interpolate add 1.67 m/min for each 0.1 km/h.

**NOTE:** Since 1 mph equals 88 fpm (5280 ÷ 60), to interpolate add 8.8 fpm for every 0.1 mph.

1 mph = 26.9 m/min.

## BEARING POWERS

MATERIAL	BEARING POWER			
	Bar	lb/in <sup>2</sup>	Metric t/m <sup>2</sup>	U.S. tons/ft <sup>2</sup>
Rock (semi- shattered) . . . .	4.8	70	50	5
Rock (solid) . . . . .	24.1	350	240	24
Clay, dry. . . . .	3.8	55	40	4
medium dry . . . . .	1.9	27	20	2
soft . . . . .	1.0	14	10	1
Gravel, cemented . . . . .	7.6	110	80	8
Sand, compact dry . . . . .	3.8	55	40	4
clean dry . . . . .	1.9	27	20	2
Quicksand & alluvial soil . .	0.5	7	5	0.5

## AGRICULTURAL COMMODITIES CONVERSION FACTORS

	lb	kg	Metric Ton
1 Bushel of Corn*	56	25.40	0.02540
1 Bushel of Soybean*	60	27.22	0.02721
1 Bushel of Oats*	32	14.51	0.01451
1 Bushel of Wheat*	60	27.22	0.02721
1 Bale of Cotton	478	216.81	0.21681
1 metric ton of Corn	39.37 Bushels*		
1 metric ton of Soybean	36.75 Bushels*		
1 metric ton of Oats	68.92 Bushels*		
1 metric ton of Wheat	36.75 Bushels*		
1 metric ton of Cotton	4.61 Bales		

\*Bushel is a volume measurement, 1 Bushel = 35.24 liters = 9.31 U.S. Gallons. In the agricultural mercantile exchange, the Bushel is widely used for grains as weight. For the above weights, the market assumes a standard density for each type of grain.

### CURVE SUPERELEVATION IN PERCENT GRADE, TO PROVIDE NO LATERAL TIRE FORCE

Negotiating curves can generate high lateral tire forces. These forces contribute to high tire wear and ply separation. Superelevating the curve helps eliminate these forces. The amount of superelevation depends on the curve's radius and the speed at which it is negotiated.

The following table is a guide for providing the superelevation necessary to eliminate lateral forces.

Superelevated turns present a danger when slippery. For this reason, curves superelevated over 10% should be used with caution. Unless the proper speed is maintained, matching the elevation of the curve, a vehicle may slide off of the lower edge of the roadway. Superelevated curves should be maintained in good tractive conditions.

TURN RADIUS		Speed	Speed	Speed	Speed	Speed	Speed	Speed	Speed
m	ft	16 km/h 10 mph	24 km/h 15 mph	32 km/h 20 mph	40 km/h 25 mph	48 km/h 30 mph	56 km/h 35 mph	64 km/h 40 mph	72 km/h 45 mph
15.2	50	13%	30%	—	—	—	—	—	—
30.5	100	7%	15%	27%	—	—	—	—	—
45.7	150	4%	10%	18%	28%	—	—	—	—
61.0	200	3%	8%	13%	21%	30%	—	—	—
91.5	300	2%	5%	9%	14%	20%	27%	—	—
152.4	500	1%	3%	5%	8%	12%	16%	21%	27%
213.4	700	1%	2%	4%	6%	9%	12%	15%	19%
304.9	1000	1%	2%	3%	4%	6%	8%	11%	14%

### MAXIMUM SPEED ON CURVES FOR VARIOUS SUPERELEVATION GRADES WITH A 0.20 LATERAL COEFFICIENT OF TRACTION

Another approach to superelevated curves is to determine the safe speed for negotiating a turn at a certain lateral tire force. In general, a 20% lateral coefficient of traction is conservative for all but ice and slippery conditions, making table values safe to use for most applications. The following table shows maximum speed with various superelevations to maintain a 0.20 lateral coefficient of traction.

A transition section may be necessary at higher speeds when entering or departing from a superelevated turn.

TURN RADIUS		Flat Curve		5% Super-elevation		10% Super-elevation	
m	ft	km/h	mph	km/h	mph	km/h	mph
7.6	25	14	9	16	10	17	11
15.2	50	20	12	22	14	24	15
30.5	100	28	17	31	19	34	21
45.7	150	34	21	38	24	42	26
61.0	200	39	24	44	27	48	30
91.5	300	48	30	54	34	59	37
152	500	62	39	70	43	76	47
213	700	74	46	—	—	—	—



## Tables

WEIGHT* OF MATERIALS	LOOSE		BANK		LOAD FACTORS
	kg/m <sup>3</sup>	lb/yd <sup>3</sup>	kg/m <sup>3</sup>	lb/yd <sup>3</sup>	
Basalt . . . . .	1960	<b>3300</b>	2970	<b>5000</b>	0.67
Bauxite, Kaolin . . . . .	1420	<b>2400</b>	1900	<b>3200</b>	0.75
Caliche . . . . .	1250	<b>2100</b>	2260	<b>3800</b>	0.55
Carnotite, uranium ore . . . . .	1630	<b>2750</b>	2200	<b>3700</b>	0.74
Cinders . . . . .	560	<b>950</b>	860	<b>1450</b>	0.66
Clay — Natural bed . . . . .	1660	<b>2800</b>	2020	<b>3400</b>	0.82
Dry . . . . .	1480	<b>2500</b>	1840	<b>3100</b>	0.81
Wet . . . . .	1660	<b>2800</b>	2080	<b>3500</b>	0.80
Clay & gravel — Dry . . . . .	1420	<b>2400</b>	1660	<b>2800</b>	0.85
Wet . . . . .	1540	<b>2600</b>	1840	<b>3100</b>	0.85
Coal — Anthracite, Raw . . . . .	1190	<b>2000</b>	1600	<b>2700</b>	0.74
Washed . . . . .	1100	<b>1850</b>			0.74
Ash, Bituminous Coal . . . . .	530-650	<b>900-1100</b>	590-890	<b>1000-1500</b>	0.93
Bituminous, Raw . . . . .	950	<b>1600</b>	1280	<b>2150</b>	0.74
Washed . . . . .	830	<b>1400</b>			0.74
Decomposed rock —					
75% Rock, 25% Earth . . . . .	1960	<b>3300</b>	2790	<b>4700</b>	0.70
50% Rock, 50% Earth . . . . .	1720	<b>2900</b>	2280	<b>3850</b>	0.75
25% Rock, 75% Earth . . . . .	1570	<b>2650</b>	1960	<b>3300</b>	0.80
Earth — Dry packed . . . . .	1510	<b>2550</b>	1900	<b>3200</b>	0.80
Wet excavated . . . . .	1600	<b>2700</b>	2020	<b>3400</b>	0.79
Loam . . . . .	1250	<b>2100</b>	1540	<b>2600</b>	0.81
Granite — Broken . . . . .	1660	<b>2800</b>	2730	<b>4600</b>	0.61
Gravel — Pitrun . . . . .	1930	<b>3250</b>	2170	<b>3650</b>	0.89
Dry . . . . .	1510	<b>2550</b>	1690	<b>2850</b>	0.89
Dry 6-50 mm (1/4"-2") . . . . .	1690	<b>2850</b>	1900	<b>3200</b>	0.89
Wet 6-50 mm (1/4"-2") . . . . .	2020	<b>3400</b>	2260	<b>3800</b>	0.89
Gypsum — Broken . . . . .	1810	<b>3050</b>	3170	<b>5350</b>	0.57
Crushed . . . . .	1600	<b>2700</b>	2790	<b>4700</b>	0.57
Hematite, iron ore, high grade . . . . .	1810-2450	<b>4000-5400</b>	2130-2900	<b>4700-6400</b>	0.85
Limestone — Broken . . . . .	1540	<b>2600</b>	2610	<b>4400</b>	0.59
Crushed . . . . .	1540	<b>2600</b>	—	—	—
Magnetite, iron ore . . . . .	2790	<b>4700</b>	3260	<b>5500</b>	0.85
Pyrite, iron ore . . . . .	2580	<b>4350</b>	3030	<b>5100</b>	0.85
Sand — Dry, loose . . . . .	1420	<b>2400</b>	1600	<b>2700</b>	0.89
Damp . . . . .	1690	<b>2850</b>	1900	<b>3200</b>	0.89
Wet . . . . .	1840	<b>3100</b>	2080	<b>3500</b>	0.89
Sand & clay — Loose . . . . .	1600	<b>2700</b>	2020	<b>3400</b>	0.79
Compacted . . . . .	2400	<b>4050</b>			
Sand & gravel — Dry . . . . .	1720	<b>2900</b>	1930	<b>3250</b>	0.89
Wet . . . . .	2020	<b>3400</b>	2230	<b>3750</b>	0.91
Sandstone . . . . .	1510	<b>2550</b>	2520	<b>4250</b>	0.60
Shale . . . . .	1250	<b>2100</b>	1660	<b>2800</b>	0.75
Slag — Broken . . . . .	1750	<b>2950</b>	2940	<b>4950</b>	0.60
Snow — Dry . . . . .	130	<b>220</b>			
Wet . . . . .	520	<b>860</b>			
Stone — Crushed . . . . .	1600	<b>2700</b>	2670	<b>4500</b>	0.60
Taconite . . . . .	1630-1900	<b>3600-4200</b>	2360-2700	<b>5200-6100</b>	0.58
Top Soil . . . . .	950	<b>1600</b>	1370	<b>2300</b>	0.70
Taprock — Broken . . . . .	1750	<b>2950</b>	2610	<b>4400</b>	0.67
Wood Chips** . . . . .	—	—	—	—	—

\*Varies with moisture content, grain size, degree of compaction, etc. Tests must be made to determine exact material characteristics.

\*\*Weights of commercially important wood species can be found in the last pages of the Logging & Forest Products section. To obtain wood weights use the following equations: lb/yd<sup>3</sup> = (lb/ft<sup>3</sup>) × .4 × 27  
kg/m<sup>3</sup> = (kg/m<sup>3</sup>) × .4

## ALTITUDE DERATION

### PERCENT FLYWHEEL HORSEPOWER AVAILABLE AT SPECIFIED ALTITUDES

MODEL	0-760 m (0-2500')	760-1500 m (2500-5000')	1500-2300 m (5000-7500')	2300-3000 m (7500-10,000')	3000-3800 m (10,000-12,500')	3800-4600 m (12,500-15,000')
D3K XL	100	100	100	100	88	85
D3K LGP	100	100	100	100	88	85
D4K XL	100	100	100	100	88	85
D4K LGP	100	100	100	100	88	85
D5K XL	100	100	100	100	88	85
D5K LGP	100	100	100	100	88	85
D5R2 XL & LGP	100	100	100	100	N/A	N/A
D5T XL	100	100	100	100	N/A	N/A
D6K2 XL & LGP	100	100	100	100	N/A	N/A
D6N XL & LGP*	100	100	100	100	100	100
D6R Series 3 (All)	100	100	100	100	92	84
D6R2	100	100	100	100	92	84
D6T <sup>1</sup>	100	100	100	100	100	100
D7E	100	100	100	100	99	95
D7R	100	100	100	100	100	96
D8R	100	100	100	93	85	77
D8T	100	100	100	100	100	100
D9R	100	100	100	93	85	77
D9T <sup>1</sup>	100	100	100	100	100	100
D9T <sup>2</sup>	100	100	100	99	92	83
D9T <sup>3</sup>	100	100	100	100	100	100
D9T <sup>4</sup>	100	100	100	98	91	80
D9T <sup>5</sup>	100	100	100	100	99	88
D10T2 <sup>5**</sup>	100	100	100	100	100	100
D10T2 <sup>6**</sup>	100	100	100	100	100	100
D11T/D11T CD <sup>5***</sup>	100	100	100	100	100	86
D11T/D11T CD <sup>6***</sup>	100	100	100	100	83	67

\*Information not available at time of printing.

\*\*In forward gears.

\*\*\*D11T — High altitude arrangement available.

<sup>1</sup> Meets Tier 4 Final/Stage IV/Japan 2014 (Tier 4 Final) emission standards.

<sup>2</sup> Meets Tier 3 equivalent emission standards, North America — Standard Altitude.

<sup>3</sup> Meets Tier 3 equivalent emission standards, North America — High Altitude.

<sup>4</sup> Meets Stage IIIA/Japan 2006 (Tier 3) equivalent emission standards.

<sup>5</sup> Meets Tier 2/Stage II/Japan 2001 (Tier 2) equivalent emission standards.

<sup>6</sup> Meets Tier 4 Final.

## Tables

### ALTITUDE DERATION (Continued)

MODEL	0-760 m (0-2500')	760-1500 m (2500-5000')	1500-2300 m (5000-7500')	2300-3000 m (7500-10,000')	3000-3800 m (10,000-12,500')	3800-4600 m (12,500-15,000')
120K	100	100	100	97	92	85
120K2	100	100	100	97	92	85
120M	100	100	100	100	95	88
120M AWD	100	98	96	94	89	85
120M2	100	100	100	100	94	82
120M2 AWD	100	100	100	100	94	82
12K	100	99	98	94	89	85
12M	100	100	100	100	95	88
12M2	100	100	100	100	100	100
12M2 AWD	100	100	100	100	100	99
12M3	100	100	100	100	100	100
12M3 AWD	100	100	100	100	100	98
140K	100	100	100	100	92	90
140K2	100	100	100	100	92	90
140M	100	100	100	100	92	90
140M AWD	100	100	100	100	92	90
140M2	100	100	100	100	100	99
140M2 AWD	100	100	100	100	97	93
140M3	100	100	100	100	100	98
140M3 AWD	100	100	100	100	100	90
160K	100	100	100	100	92	90
160M	100	100	100	100	92	90
160M AWD	100	100	100	100	92	90
160M2	100	100	100	99	95	91
160M2 AWD	100	100	100	99	94	88
160M3	100	100	100	100	100	90
160M3 AWD	100	100	100	100	98	83
14M3*	100	100	100	100	100	97
14M3**	100	100	100	100	100	100
14M3***	100	100	100	100	100	100
16M3*	100	100	100	100	100	100
16M3**	100	100	100	100	100	95
16M3***	100	100	100	100	100	100
18M3*	100	100	100	100	100	100
18M3**	100	100	100	100	100	95
18M3***	100	100	100	100	100	100
24M B9K**	100	100	95	90	80	70
24M B9K Unregulated	100	100	100	100	90	85
24M B93**	100	100	100	98	89	75
24M B93*	100	100	100	100	91	86

\*Meets Tier 2/Stage II/Japan 2001 (Tier 2) equivalent emission standards.

\*\*Meets Tier 3/Stage IIIA/Japan 2006 (Tier 3) equivalent emission standards.

\*\*\*Meets Tier 4 Final/Stage IV/Japan 2014 (Tier 4 Final) emission standards.

## ALTITUDE DERATION (Continued)

MODEL	0-760 m (0-2500')	760-1500 m (2500-5000')	1500-2300 m (5000-7500')	2300-3000 m (7500-10,000')	3000-3800 m (10,000-12,500')	3800-4600 m (12,500-15,000')
216B3	100	89	81	72	61	52
226B3	100	97	95	91	87	83
236D	95	88	81	76	N/A	N/A
242D	95	88	81	76	N/A	N/A
246D	95	88	81	76	N/A	N/A
257D	95	88	81	76	N/A	N/A
259D	95	88	81	76	N/A	N/A
262D	95	88	81	76	N/A	N/A
272D2	95	88	81	76	N/A	N/A
272D2 XHP	95	88	81	76	N/A	N/A
277D	95	88	81	76	N/A	N/A
279D	95	88	81	76	N/A	N/A
287D	95	88	81	76	N/A	N/A
289D	95	88	81	76	N/A	N/A
297D2	95	88	81	76	N/A	N/A
297D2 XHP	95	88	81	76	N/A	N/A
299D2	95	88	81	76	N/A	N/A
299D2 XHP	95	88	81	76	N/A	N/A
300.9D	80	80	80	80	80	80
301.4C	80	80	80	80	80	80
301.7D	80	80	80	80	80	80
301.7D CR	80	80	80	80	80	80
302.2D	80	80	80	80	80	80
302.4D	80	80	80	80	80	80
302.7D CR	80	80	80	80	80	80
303E CR	91	82	73	66	N/A	N/A
303.5E CR	91	82	73	66	N/A	N/A
303.5E2 CR	91	82	73	66	N/A	N/A
304E2 CR	91	82	73	66	N/A	N/A
304.5E2 XTC	91	82	73	66	N/A	N/A
305E2 CR	91	82	73	66	N/A	N/A
305.5E2 CR	91	82	73	66	N/A	N/A
306E2	95	88	81	76	N/A	N/A
307E	95	88	81	76	N/A	N/A
307E2	95	88	81	76	N/A	N/A
308E2 CR	95	88	81	76	N/A	N/A
308E2 CR VAB	95	88	81	76	N/A	N/A
311D LRR	100	100	100	*	*	*
312D/312D L**	100	100	100	*	*	*
312D/312D L***	97	95	92	*	*	*
313C SR/CR	100	100	100	83	78	73
314D CR/314D LCR	100	100	100	*	*	*
315D L**	100	100	100	*	*	*
315D L***	97	95	92	*	*	*
319D L/319 D LN	97	95	92	*	*	*

\*Information not available at time of printing.

\*\*Japan Sourced.

\*\*\*France Sourced.

## Tables

### ALTITUDE DERATION (Continued)

MODEL	0-760 m (0-2500')	760-1500 m (2500-5000')	1500-2300 m (5000-7500')	2300-3000 m (7500-10,000')	3000-3800 m (10,000-12,500')	3800-4600 m (12,500-15,000')
M313C	100	97	95	91	N/A	N/A
M315C	100	97	95	91	N/A	N/A
M316C	*	*	*	*	*	*
M318C	100	100	97	95	N/A	N/A
M322C	100	100	97	95	N/A	N/A
M313D	100	100	100	100	*	*
M315D	100	100	100	100	*	*
M316D	100	100	100	100	100	98.9
M318D	100	100	100	100	96.6	91.8
M322D	100	100	100	100	96.1	91.9
M315D2	100	100	100	100	*	*
M317D2	100	100	100	100	*	*
M320D2	100	100	100	100	*	*
M318F	100	100	100	100	*	*
M320F	100	100	100	100	*	*
320E/320E L/320E RR/320E LRR	100	100	100	*	*	*
320D2/320D2 L	100	100	100	100	*	*
320D2 GC	100	100	100	*	*	*
323D2 L	100	100	100	100	*	*
320F L	100	100	100	100	*	*
323F L	100	100	100	100	*	*
323F LN	100	100	100	100	*	*
326D2 L	100	100	100	100	100-96	96-92
326F L/326F LN	100	100	100	100	*	*
330D2 L	100	100	100	100	100-96	96-92
330F L/330F LN	100	100	100	100	*	*
335F L	100	100	100	100	*	*
336F/336F L	100	100	100	*	*	*
336F XE/336F L XE	100	100	100	*	*	*
336D2/336D2 L/336D2 GC/340D2 L	100	100	100	100	*	*
336D2 XE/336D2 L XE	100	100	100	*	*	*
349D2/349D2 L	100	100-96	96	96-89	89-82	82-74
349F L/352F	100	100	100	*	*	*
349F L XE/352F XE	100	100	100	*	*	*
374F L <sup>2</sup>	100	100	100	100	99	94
374F L <sup>1</sup>	100	100	100	100	100	95
374F L <sup>3</sup>	100	100	100	100	100	95.5
385C FS <sup>1</sup>	100	100	100	100	100	97
390F L <sup>2</sup>	100	100	100	100	100	97
390F L <sup>1</sup>	100	100	100	100	100	99
390F L <sup>3</sup>	100	100	100	100	100	95.5

\*Information not available at time of printing.

<sup>1</sup> Meets Tier 2/Stage II/Japan 2001 (Tier 2) equivalent emission standards.

<sup>2</sup> Meets Tier 3/Stage IIIA/Japan 2006 (Tier 3) equivalent emission standards.

<sup>3</sup> Meets Tier 4 Final/Stage IV/Japan 2014 (Tier 4 Final) emission standards.

## ALTITUDE DERATION (Continued)

MODEL	0-760 m (0-2500')	760-1500 m (2500-5000')	1500-2300 m (5000-7500')	2300-3000 m (7500-10,000')	3000-3800 m (10,000-12,500')	3800-4600 m (12,500-15,000')
422F2 (NA)	95	89	78	72	N/A	N/A
416F2 (Mech Turbo)	99	97	95	92	N/A	N/A
420F2/420F2 IT (Mech Turbo)	99	97	95	92	N/A	N/A
430F2/430F2 IT (Mech Turbo)	99	97	95	92	N/A	N/A
422F2 (Mech Turbo)	99	97	95	92	N/A	N/A
428F2 (Mech Turbo)	99	97	95	92	N/A	N/A
432F2 (Mech Turbo)	99	97	95	92	N/A	N/A
434F2 (Mech Turbo)	99	97	95	92	N/A	N/A
444F2 (Mech Turbo)	99	97	95	92	N/A	N/A
416F2 (Electronic)	100	100	100	100	N/A	N/A
420F2/420F2 IT (Electronic)	100	100	100	100	N/A	N/A
430F2/430F2 IT (Electronic)	100	100	100	100	N/A	N/A
428F2 (Electronic)	100	100	100	100	N/A	N/A
432F2 (Electronic)	100	100	100	100	N/A	N/A
434F2 (Electronic)	100	100	100	100	N/A	N/A
444F2 (Electronic)	100	100	100	100	N/A	N/A
450F (Electronic)	100	100	100	100	N/A	N/A
Forest Products:						
320D Series 2 FM <sup>3</sup>	*	*	*	*	*	*
320D Series 2 FM LL <sup>3</sup>	*	*	*	*	*	*
538 <sup>1</sup>	*	*	*	*	*	*
538 LL <sup>1</sup>	*	*	*	*	*	*
324D FM <sup>3</sup>	100	100	100	100	100	100-96
324D FM LL <sup>3</sup>	100	100	100	100	100	100-96
325D FM <sup>3</sup>	100	100	100	100	100-96	96-92
325D FM LL <sup>3</sup>	100	100	100	100	100-96	96-92
558 LL <sup>1</sup>	*	*	*	*	*	*
568 <sup>2</sup>	100	100	100	100-96	96-92	92-85
568 LL <sup>2</sup>	100	100	100	100-96	96-92	92-85
501HD	100	100	100	100	*	*
517	100	100	100	99	95	87
521B <sup>3</sup>	100	100	100	100	100	100
522B <sup>3</sup>	100	100	100	100	100	100
525D	100	100	100	100	*	*
527	100	100	100	100	99	91
535D	100	100	100	100	*	*
541 Series 2 <sup>3</sup>	100	100	100	100	100	100
545D	100	100	100	100	*	*
555D	100	100	100	100	*	*
552 Series 2 <sup>3</sup>	100	100	100	100	100	100
PL61	100	100	100	100	N/A	N/A
572R2	100*	100*	100*	94	86	80
PL83	100	100	100	100	94	87
PL87	100	100	94	87	80	73

\*Information not available at time of printing.

**NOTE:** Contact factory for deration estimates based upon site specific temperatures and altitudes for altitude range of 3800 to 4600 m (12,500 to 15,000 ft).

<sup>1</sup> Meets Tier 4 Final/Stage IV/Japan 2014 (Tier 4 Final) emission standards.

<sup>2</sup> Meets Tier 4 Interim/Stage IIIB/Japan 2011 (Tier 4 Interim) equivalent emission standards.

<sup>3</sup> Meets Tier 3/Stage IIIA/Japan 2006 (Tier 3) equivalent emission standards.

## Tables

### ALTITUDE DERATION (Continued)

MODEL	0-760 m (0-2500')	760-1500 m (2500-5000')	1500-2300 m (5000-7500')	2300-3000 m (7500-10,000')	3000-3800 m (10,000-12,500')	3800-4600 m (12,500-15,000')
621K	100	100	100	98	80	64
623K	100	100	100	98	80	64
627K Tractor	100	100	100	98	80	64
Scraper	100	100	100	100	98	94
631K	100	100	100	100	97	90
637K Tractor◄	100	100	100	100	97	90
Scraper◄	100	100	100	98	80	64
657G Tractor◄	100	100	100	94	88	81
Scraper◄	100	100	100	95	90	84
770G <sup>1</sup>	100	100	100	100-98	98-95	95-83
770G <sup>2,3</sup>	100	100	100	100	100-95	95-83
772G <sup>1</sup>	100	100	100	100-98	98-95	95-83
772G <sup>2,3</sup>	100	100	100	100	100-98	98-80
773E <sup>3</sup>	100	100	100	100	100	100
773G <sup>2</sup>	100	100	100	100	100-96	96-94
773G <sup>3</sup>	100	100	100	100	100	100
775G <sup>1</sup>	100	100	100	100	100-96	96-94
775G <sup>3</sup>	100	100	100	100	100	100-99
777E <sup>3</sup>	100	100	100	100	100-99.5	99.5-91
777G <sup>1</sup>	100	100	100	100-95	95-86	86-75
777G <sup>3</sup>	100	100	100	100	100	100
785C 1450 HP <sup>4</sup>	100	100	100	100	100-92.5	92.5-85
785D 1450 HP <sup>3</sup>	100	100	100	100	100	100-97
789D 1900 HP <sup>4</sup>	100	100	100	100-92.5	92.5-85	85-77.5
789D 2100 HP <sup>4</sup>	100	100	100	100	100-98.5	98.5-91
789D 2100 HP <sup>3</sup>	100	100	100	100-97	97-89.5	89.5-82
793D 2415 HP <sup>4</sup>	100	100	100	100-97	97-89.5	89.5-82
793D HAA 2300 HP <sup>4</sup>	100	100	100	100	100-98.5	98.5-91
793F 2650 HP FO <sup>4</sup>	100	100	100	100	100-94.5	94.5-87
793F 2650 HP <sup>3</sup>	100	100	100	100	100-95.5	95.5-88
793F HAA 2650 HP <sup>4</sup>	100	100	100	100	100	100
794 AC 3500 HP <sup>4</sup>	100	100	100	100-95	95-90	90-85
794 AC 3500 HP <sup>3</sup>	100	100	100	100-98	98-90	90-80
795F AC 3400 HP <sup>4</sup>	100	100	100	100-95	95-90	90-85
795F AC 3400 HP <sup>3</sup>	100	100	100	100-93	93-87	87-81
797F 4000 HP FO <sup>4</sup>	100	100	100-88	88-80	80-73	70-61
797F 4000 HP <sup>3</sup>	100	100	100-88	88-80	80-70	70-56
797F HAA 4000 HP <sup>3</sup>	100	100	100	100	100	100
814F2	*	*	*	*	*	*
824K	*	*	*	*	*	*
834K	100	100	100	100	98	85
844K	100	100	100	98	93	83
854K	100	100	100	98	93	79

\*Information not available at time of printing.

◄ EUI engine — Automatic altitude deration.

<sup>1</sup> Meets Tier 4 Final/Stage IV/Japan 2014 (Tier 4 Final) emission standards.

<sup>2</sup> Meets Tier 3 equivalent emission standards.

<sup>3</sup> Meets Tier 2 equivalent emission standards.

<sup>4</sup> Meets Tier 1 equivalent emission standards.

HAA = High Altitude Engine Arrangement; FO = Fuel Optimized Engine Calibration

**NOTE:** Contact factory for deration estimates based upon site specific temperatures and altitudes for altitude range of 3800 to 4600 m (12,500 to 15,000 ft).

## ALTITUDE DERATION (Continued)

MODEL	0-760 m (0-2500')	760-1500 m (2500-5000')	1500-2300 m (5000-7500')	2300-3000 m (7500-10,000')	3000-3800 m (10,000-12,500')	3800-4600 m (12,500-15,000')
815F2	*	*	*	*	*	*
825K	*	*	*	*	*	*
816F2	*	*	*	*	*	*
826H	*	*	*	*	*	*
836H	*	*	*	*	*	*
901C2 (Japan)	91	82	73	66	N/A	N/A
902C2 (Japan)	91	82	73	66	N/A	N/A
903C2	91	82	73	66	N/A	N/A
906K/M	95	88	81	76	N/A	N/A
907K/M	95	88	81	76	N/A	N/A
908K/M	95	88	81	76	N/A	N/A
910K/M	100	100	100	100	N/A	N/A
914K/M	100	100	100	100	N/A	N/A
918M	100	100	100	100	N/A	N/A
924K	100	100	100	100	98	96
926M <sup>1</sup>	100	100	100	100	92	81
930K	100	100	100	100	98	96
930M <sup>1</sup>	100	100	100	100	90	77
938K	100	100	100	100	98	96
938M <sup>1</sup>	100	100	100	100	82	66
950 GC <sup>1</sup>	100	100	100	100	99	97
950 GC <sup>3</sup>	100	100	100	98	96	92
950H <sup>3</sup>	100	100	100	100	100	N/A
950K <sup>2</sup>	100	100	100	100	98	95
950L <sup>3</sup>	100	100	99	96	93	90
950M <sup>1</sup>	100	100	100	100	97	91
950M <sup>3</sup>	100	100	99	96	93	90
962H <sup>3</sup>	100	100	100	100	100	N/A
962K <sup>2</sup>	100	100	100	100	98	91
962L <sup>3</sup>	100	100	99	96	93	90
962M <sup>1</sup>	100	100	100	100	95	84
962M <sup>3</sup>	100	100	99	96	93	90
966H <sup>3</sup>	100	100	100	100	100	100
966K <sup>2</sup>	100	100	100	100	94	86
966L <sup>3</sup>	100	100	100	100	96	84
966L <sup>4</sup>	100	100	100	100	100	97
966M <sup>1</sup>	100	100	100	99	91	79
966M <sup>3</sup>	100	100	100	100	96	84
966M <sup>4</sup>	100	100	100	100	100	97
966M XE <sup>1</sup>	100	100	100	98	93	84

\*Information not available at time of printing.

<sup>1</sup> Meets Tier 4 Final/Stage IV/Japan 2014 (Tier 4 Final) emission standards.

<sup>2</sup> Meets Tier 4 Interim/Stage IIIB/Japan 2011 (Tier 4 Interim) equivalent emission standards.

<sup>3</sup> Meets Tier 3/Stage IIIA/Japan 2006 (Tier 3) equivalent emission standards.

<sup>4</sup> Meets Tier 2/Stage II/Japan 2001 (Tier 2) equivalent emission standards.

**NOTE:** Products are not available in all regions. Contact your local Cat® dealer for product availability.



## Tables

### ALTITUDE DERATION (Continued)

MODEL	0-760 m (0-2500')	760-1500 m (2500-5000')	1500-2300 m (5000-7500')	2300-3000 m (7500-10,000')	3000-3800 m (10,000-12,500')	3800-4600 m (12,500-15,000')
972H <sup>3</sup>	100	100	100	100	100	100
972K <sup>2</sup>	100	100	100	100	93	84
972L <sup>3</sup>	100	100	100	95	85	75
972L <sup>4</sup>	100	100	100	100	95	90
972M <sup>1</sup>	100	100	100	99	89	79
972M <sup>3</sup>	100	100	100	95	85	75
972M <sup>4</sup>	100	100	100	100	95	90
972M XE <sup>1</sup>	100	100	100	98	93	84
980H <sup>3</sup>	100	100	100	100	100-93	93-84
980K <sup>2</sup>	100	100	100	100	100	88
980L <sup>3</sup>	100	100	100	98	91	85
980L <sup>4</sup>	100	100	100	100	98	93
980M <sup>1</sup>	100	100	100	100	100	88
980M <sup>3</sup>	100	100	100	98	91	85
980M <sup>4</sup>	100	100	100	100	98	93
982M <sup>1</sup>	100	100	100	98	94	86
982M <sup>3</sup>	100	100	100	98	91	85
982M <sup>4</sup>	100	100	100	100	98	93
986H <sup>4</sup>	100	100	100	99	98	85
986H <sup>3</sup>	100	100	95	94	89	75
988K	100	100	100	100	98	85
990K	100	100	100	98	93	83
992K	100	100	100	98	93	79
993K	100	100	100	99	93	89
994K	100	100	100	100	99	97
953D	100	100	100	100	N/A	N/A
953K	100	100	100	100	98	95
963D	100	100	100	100	N/A	N/A
963K	100	100	100	100	98	95
973C	100	100	100	100	100	98
TH220B	99	97	95	91	N/A	N/A
TH330B	99	97	95	91	N/A	N/A
TH360B	99	97	95	91	N/A	N/A
TH560B	99	97	95	91	N/A	N/A
TH580B	99	97	95	91	N/A	N/A

<sup>1</sup> Meets Tier 4 Final/Stage IV/Japan 2014 (Tier 4 Final) emission standards.

<sup>2</sup> Meets Tier 4 Interim/Stage IIIB/Japan 2011 (Tier 4 Interim) equivalent emission standards.

<sup>3</sup> Meets Tier 3/Stage IIIA/Japan 2006 (Tier 3) equivalent emission standards.

<sup>4</sup> Meets Tier 2/Stage II/Japan 2001 (Tier 2) equivalent emission standards.

**NOTE:** Products are not available in all regions. Contact your local Cat dealer for product availability.

## ALTITUDE DERATION (Continued)

MODEL	0-760 m (0-2500')	760-1500 m (2500-5000')	1500-2300 m (5000-7500')	2300-3000 m (7500-10,000')	3000-3800 m (10,000-12,500')	3800-4600 m (12,500-15,000')
PM620 <sup>1</sup>	100	100	100	100-91	91-82	82-74
PM620 <sup>2</sup>	100-99	99-97	97-90	90-81	81-73	73-62
PM622 <sup>1</sup>	100	100	100	100-91	91-82	82-74
PM622 <sup>2</sup>	100-99	99-97	97-90	90-81	81-73	73-62
RM500B <sup>1</sup>	100	100	100-93	93-84	84-76	76-68
AP600F <sup>1</sup>	100	99	99-98	98	98-94	94-92
AP655F <sup>1</sup>	100	99	99-98	98	98-94	94-92
CS423E	100	100-93	93-85	85-77	77-64	64-53
CS44B <sup>1</sup>	100-99	99-98	98-96	96	96-83	83-76
CS44B <sup>2</sup>	100	100	95	95	TBD	TBD
CP44B <sup>1</sup>	100-99	99-98	98-96	96	96-83	83-76
CP44B <sup>2</sup>	100	100	95	95	TBD	TBD
CS533E	100	100	100-97	97-93	93-89	89-83
CS533E XT	100	100	100-97	97-93	93-89	89-83
CP533E	100	100	100-97	97-93	93-89	89-83
CB22B <sup>1</sup>	100-96	96-89	89-81	81-72	72-61	61-50
CB22B <sup>2</sup>	100-100	100-99	99-95	95-92	92-87	87-82
CB24B XT <sup>1</sup>	100-96	96-89	89-81	81-72	72-61	61-50
CB24B XT <sup>2</sup>	100-100	100-99	99-95	95-92	92-87	87-82
CC24B <sup>1</sup>	100-96	96-89	89-81	81-72	72-61	61-50
CC24B <sup>2</sup>	100-100	100-99	99-95	95-92	92-87	87-82
CB32B <sup>1</sup>	100-96	96-89	89-81	81-72	72-61	61-50
CB32B <sup>2</sup>	100-100	100-99	99-95	95-92	92-87	87-82
CB34B	100-96	96-89	89-81	81-72	72-61	61-50
CC34B	100-96	96-89	89-81	81-72	72-61	61-50
CB36B	100-96	96-89	89-81	81-72	72-61	61-50
CB44B <sup>1</sup>	100-99	99-98	98-96	96	96-83	83-76
CB44B <sup>2</sup>	100	100	95	95	TBD	TBD
CD44B	100	100	95	95	TBD	TBD
CB46B <sup>1</sup>	100-99	99-98	98-96	96	96-83	83-76
CB46B <sup>2</sup>	100	100	95	95	TBD	TBD
CD54B	100	100	95	95	TBD	TBD
CW14 <sup>1</sup>	100-99	99-98	98-96	96	96-83	83-76
CW14 <sup>2</sup>	100	100	95	95	TBD	TBD
CW16 <sup>1</sup>	100-99	99-98	98-96	96	96-83	83-76
CW16 <sup>2</sup>	100	100	95	95	TBD	TBD
PS150C	95	89	81	71	N/A	N/A

<sup>1</sup> Meets Tier 3/Stage IIIA equivalent emission standards.

<sup>2</sup> Meets Tier 4 Final/Stage IV emission standards.

TBA = To Be Determined

## Tables

### ALTITUDE DERATION (Continued)

MODEL	0-760 m (0-2500')	760-1500 m (2500-5000')	1500-2300 m (5000-7500')	2300-3000 m (7500-10,000')	3000-3800 m (10,000-12,500')	3800-4600 m (12,500-15,000')
R1300G†	100	100	100	100	100	100
R1600H†	100	100	100	100	100-97	97-94
R1600H (VR)^†	100	100	100-99	99-94	94-88	88-81
R1700G†	100	100	100	100	100-95	90
R1700G (VR)^†	*	*	*	*	*	*
R2900G†	*	*	*	*	*	*
R2900G (VR)^†	100-99	99-98	98-98	98-97	97-90	90-81
R3000H†	*	*	*	*	*	*
R3000H (VR)^†	100-99	99-98	98-98	98-97	97-90	90-81
AD30†	100	100	100	100	100-97	90
AD30 (VR)^†	100	100	100	100	100-97	90
AD45B†	100	100	100	100-97	97-91	83
AD55†	*	*	*	*	*	*
AD60†	*	*	*	*	*	*
6015B <sup>2</sup> ◄	100	100	100	100	100-98	98-97
6015B <sup>3</sup>	100	100	100	100	100	100-99
6020B◄	100	100	100	100	100-99	99-98
6030/6030 FS◄	100-99	99-89	89-82	82-76	76-72	72-69
6040/6040 FS◄	100	100	100	100-96	96-87	87-79
6050/6050 FS <sup>4</sup>	100	100	100	100-90	90-78	78-64
6050/6050 FS <sup>5</sup> ◄	100	100	100	100	100	93-83
6060/6060 FS◄	100	100	100	100	100	96-87
6090 FS <sup>6</sup> ◄	100	100	100	100	100	100

<sup>1</sup> Meets Tier 3/Stage IIIA/Japan 2006 (Tier 3) equivalent emission standards.

<sup>2</sup> Meets Tier 4 Final/Stage IV/Japan 2014 (Tier 4 Final) emission standards.

<sup>3</sup> Meets Tier 1/Stage I OR Tier 2/Stage II/Japan 2001 (Tier 2) equivalent emission standards.

<sup>4</sup> K1500E engines, derating is based on a different rating methodology at lower ambient temperatures.

<sup>5</sup> QSK38 engines, derating is based on a different rating methodology at lower ambient temperatures.

<sup>6</sup> QSK60 engines, derating is based on a different rating methodology at lower ambient temperatures.

\*Information not available at time of printing.

◄ Automatic altitude deration.

^ Ventilation Reduction engine option.

† Assumes ambient air temperature of 25° C (77° F).

**NOTE:** Derates are reported as a percentage of power and highlights the change from the start to the end elevation in a given column. Contact factory for deration estimates based upon site specific temperatures and altitudes.

**GRADE COMPARISON CHART  
DEGREES – PERCENT – SLOPE**

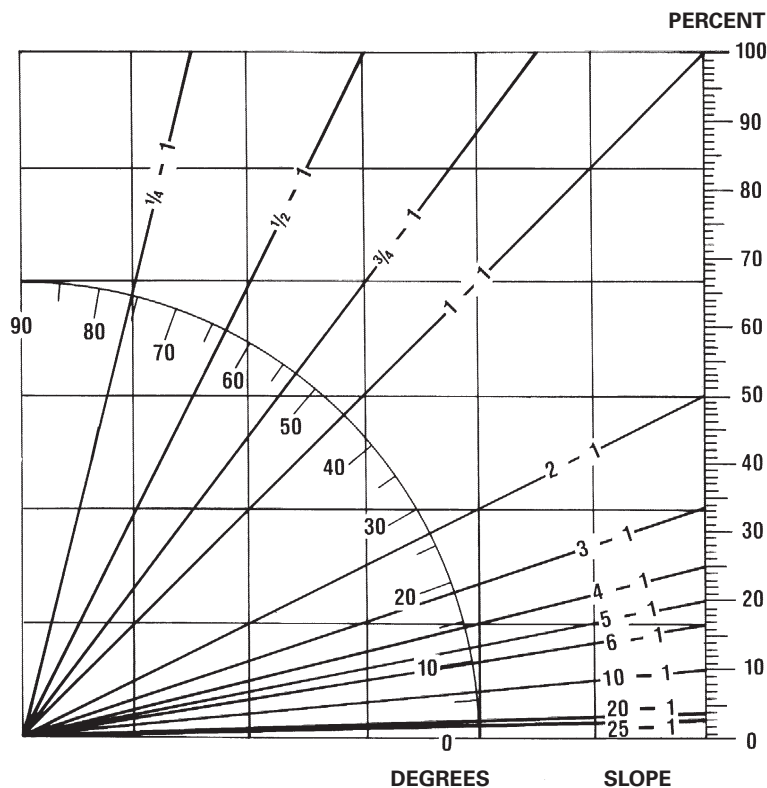

**GRADE IN DEGREES  
AND PERCENTS**

DEGREES	PERCENT
1	1.8
2	3.5
3	5.2
4	7.0
5	8.8
6	10.5
7	12.3
8	14.0
9	15.8
10	17.6
11	19.4
12	21.3
13	23.1
14	24.9
15	26.8
16	28.7
17	30.6
18	32.5
19	34.4
20	36.4
21	38.4
22	40.4
23	42.4
24	44.5
25	46.6
26	48.8
27	51.0
28	53.2
29	55.4
30	57.7
31	60.0
32	62.5
33	64.9
34	67.4
35	70.0
36	72.7
37	75.4
38	78.1
39	81.0
40	83.9
41	86.9
42	90.0
43	93.3
44	96.6
45	100.0

# Tables

## CONVERSION FACTORS

Multiply Metric Unit	By	To Obtain English Unit	Multiply English Unit	By	To Obtain Metric Unit
kilometer (km)	0.6214	mile	mile, statute (m)	1.609	kilometer
meter (m)	1.0936	yard	yard (yd)	0.9144	meter
meter (m)	3.28	foot	foot (ft)	0.3048	meter
centimeter (cm)	0.0328	foot	inch (in)	25.4	millimeter
millimeter (mm)	0.03937	inch	sq mile (mile <sup>2</sup> )	2.590	sq kilometer
sq kilometer (km <sup>2</sup> )	0.3861	square mile	acre	0.4047	hectare
hectare (ha)	2.471	acre	sq foot (ft <sup>2</sup> )	0.0929	sq meter
sq meter (m <sup>2</sup> )	10.764	square foot	sq inch (in <sup>2</sup> )	0.000645	sq meter
sq meter (m <sup>2</sup> )	1550	square inch	cu yard (yd <sup>3</sup> )	0.7645	cu meter
sq centimeter (cm <sup>2</sup> )	0.1550	square inch	cu inch (in <sup>3</sup> )	16.387	cu centimeter
cu centimeter (cm <sup>3</sup> )	0.061	cubic inch	cu foot (ft <sup>3</sup> )	0.0283	cu meter
cu meter (m <sup>3</sup> )	1.308	cubic yard	cu inch (in <sup>3</sup> )	0.0164	liter
liter (L)	61.02	cubic inch	cubic yard (yd <sup>3</sup> )	764.55	liter
liter (L)	0.001308	cubic yard	mph	1.61	km/h
km/h	0.621	mph	Ton — mph	1.459	tkm/h
liter (L)	0.2642	U.S. gallon	U.S. gallon (US Gal)	3.785	liter
liter (L)	0.22	Imperial gallon	U.S. gallon	0.833	Imperial gallon
metric ton (t)	0.984	long ton	long ton (lg ton)	1.016	metric ton
metric ton (t)	1.102	short ton	short ton (sh ton)	0.907	metric ton
kilogram (kg)	2.205	pound, avdp.	pound (lb)	0.4536	kilogram
gram (g or gr)	.0353	ounce, avdp.	ounce (oz)	28.35	gram
kilonewton (kN)	225	pound (force)	pound (lb) (force)	0.00445	kilonewton
newton (N)	0.225	pound (force)	pound (lb) (force)	4.45	newton
cu centimeter (cm <sup>3</sup> )	0.0338	fluid ounce	fluid oz (fl oz)	29.57	cu centimeter
kilograms/cu meter	1.686	pounds/cu yd	lb/cu ft (lb/ft <sup>3</sup> )	16.018	kg/cu meter
kilograms/cu meter	0.062	pounds/cu ft	lb/cu yd (lb/yd <sup>3</sup> )	0.5933	kg/cu meter
kilograms/sq cm (kg/cm <sup>2</sup> )	14.225	pounds/sq in	pounds/sq. in.	0.0703	kilogram/sq cm
kilocalorie (kcal)	3.968	Btu	psi	0.0689	bar
kilogram-meter (kg•m)	7.233	foot-pound	psi	6.89	kilopascal
meter-kilogram (m•kg)	7.233	pound-foot	Btu	0.2520	kilogram-calorie
metric horsepower (CV)	0.9863	hp	foot-pound (ft-lb)	0.1383	kilogram-meter
kilowatt (kW)	1.341	hp	horsepower (hp)	1.014	metric horsepower
kilopascal (kPa)	0.145	psi	horsepower (hp)	0.7457	kilowatt
bar	14.5	psi	pounds/cu yd	0.0005928	tons/m <sup>3</sup>
tons/m <sup>3</sup>	1692	pounds/cu yd	pounds (No. 2 diesel fuel)	0.1413	U.S. gallon
decaliter	0.283	bushel	bushel	3.524	decaliter

NOTE: Some of the above factors have been rounded for convenience. For exact conversion factors please consult International System of Units (SI) table.

## Temperature conversion

### Degree C

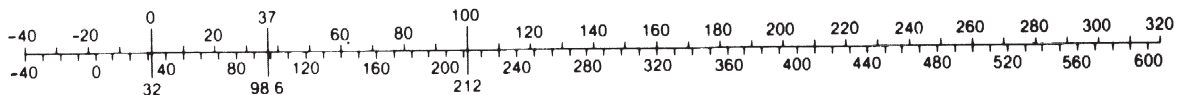

### Degree F

$$^{\circ}\text{C} = (^{\circ}\text{F} - 32) \div 1.8$$

$$^{\circ}\text{F} = (\text{C} \times 1.8) + 32$$

**METRIC UNIT EQUIVALENTS**

---

1 km	=	1000 m
1 m	=	100 cm
1 cm	=	10 mm
1 km <sup>2</sup>	=	100 ha
1 ha	=	10,000 m <sup>2</sup>
1 m <sup>2</sup>	=	10,000 cm <sup>2</sup>
1 cm <sup>2</sup>	=	100 mm <sup>2</sup>
1 m <sup>3</sup>	=	1000 liters
1 liter	=	1000 cm <sup>3</sup>
1 metric ton	=	1000 kg
1 quintal	=	100 kg
1 N	=	0.10197 kg•m/s <sup>2</sup>
1 kg	=	1000 g
1 g	=	1000 mg
1 bar	=	14.504 psi
1 cal	=	427 kg•m
	=	0.0016 cv•h
	=	0.00116 kw•h
torque unit		
1 CV	=	75 kg•m/s
1 kg/cm <sup>2</sup>	=	0.97 atmosph.

---

**ENGLISH UNIT EQUIVALENTS**

---

1 mile	=	1760 yd
1 yd	=	3 ft
1 ft	=	12 in
1 sq mile	=	640 acres
1 acre	=	43,560 sq ft
1 sq ft	=	144 sq in
1 cu ft	=	7.48 gal liq
1 gal	=	231 cu in
	=	4 quarts liq
1 quart	=	32 fl oz
1 fl oz	=	1.80 cu in
1 sh ton	=	2000 lb
1 lg ton	=	2240 lb
1 lb	=	16 oz, avdp
1 Btu	=	778 ft lb
	=	0.000393 hph
	=	0.000293 kwh
1 mechanical hp	=	550 ft-lb/sec
1 atmosph.	=	14.7 lb/in <sup>2</sup>

---

**POWER UNIT EQUIVALENTS**

---

kW	=	Kilowatt
hp	=	Mechanical Horsepower
CV	=	Cheval Vapeur (Steam Horsepower)
		French Designation For <b>Metric</b> Horsepower
PS	=	Pferdestärke (Horsepower)
		German Designation For <b>Metric</b> Horsepower
1 hp	=	1.014 CV = 1.014 PS
	=	0.7457 kW
1 PS	=	1 CV = 0.986 hp
	=	0.7355 kW
1 kW	=	1.341 hp
	=	1.36 CV
	=	1.36 PS

---

# Tables

## MACHINE/ENGINE CROSS REFERENCE

Machine Model	Engine Model	Machine Model	Engine Model	Machine Model	Engine Model
<b>Track-Type Tractors</b>		<b>Excavators</b>		<b>Excavators (continued)</b>	
D3K XL/LGP	C4.4 ACERT™	300.9D	Yanmar 3TNV70	326D2	C7.1 ACERT
D4K XL/LGP	C4.4 ACERT	301.4C	Yanmar 3TNV76	326F	C7.1 ACERT
D5K XL/LGP	C4.4 ACERT	301.7D	Yanmar 3TNV76	330D2	C7.1 ACERT
D5R	C6.6 ACERT	301.7D CR	Yanmar 3TNV76	330F	C7.1 ACERT
D5R2 XL/LGP	C7.1 ACERT	302.2D	Yanmar 3TNV76	335F	C7.1 ACERT
D5T XL	C7.1 ACERT	302.4D	Yanmar 3TNV76	336F/336F XE	C9.3 ACERT
D6K2 XL/LGP²	C7.1 ACERT	302.7D CR	Yanmar 3TNV76	336D2/340D2	C9 ACERT
D6K2 XL/LGP	C4.4 ACERT	303E CR	C1.3	336D2 XE	C9 ACERT
D6N XL/LGP	C6.6 ACERT	303.5E CR	C1.8	349D2/349D2 L	C13 ACERT
D6R2	C9 ACERT	303.5E2 CR	C1.7	349F L/352F	C13 ACERT
D6T	C9 ACERT	304E2 CR	C2.4	349F L XE/352F XE	C13 ACERT
D6T¹	C9.3 ACERT	304.5E2 CR XTC	C2.4	374F L	C15 ACERT
D7E	C9.3 ACERT	305E2 CR	C2.4	390F L	C18 ACERT
D7R	C9 ACERT	305.5E2 CR	C2.4	5110B	3412B HEUI™
D8R/D8R LGP	3406CTA	306E2	C2.4	5130B	3508B (EUI) TA
D8T/D8T LGP	C15 ACERT	307E	C2.6	5230B	3516B (EUI) TA
D9R	3408CTA	307E2 (China)	C2.6		
D9T	C18 ACERT	307E2	C2.4	<b>Front Shovels</b>	
D10T2	C27 ACERT	308E2 CR	C3.3B	385C FS	C18 ACERT
D11T/D11T CD	C32 ACERT	308E2 CR VAB	C3.3B	5130B	3508 (EUI) TA
		311F L	C3.4B	5230B	3516B (EUI) TA
		312D2/312D2 L	3054C	<b>Skid Steer/Multi-Terrain/ Compact Track Loaders</b>	
<b>Motor Graders</b>		312D2 GC	3054C	216B3	C2.2
120K	C7 ACERT	312E	C4.4 ACERT	226B3	C2.2T
120K2	C7 ACERT	313D2	3054C	226D	C2.2
120M	C6.6 ACERT	313D2/313D2 L	C4.4 ACERT	236D	C3.3B
120M AWD	C6.6 ACERT	313D2 GC	C4.4 ACERT	242D	C3.3B
120M2	C7.1 ACERT	313F L	C4.4 ACERT	246D	C3.3B
120M2 AWD	C7.1 ACERT	313F L GC	C4.4 ACERT	257D	C3.3B
12K	C7 ACERT	314E/314E L	C4.4 ACERT	259D	C3.3B
12M	C7 ACERT	315F L	C4.4 ACERT	262D	C3.3B
12M2	C9.3 ACERT	316E L	3054C	272D2	C3.8
12M2 AWD	C9.3 ACERT	316F L	C4.4 ACERT	272D2 XHP	C3.8
12M3	C9.3 ACERT	318D2 L	C4.4 ACERT	277D	C3.3B
12M3 AWD	C9.3 ACERT	318F L	C4.4 ACERT	279D	C3.3B
140K	C7 ACERT	M313D	C4.4 ACERT	287D	C3.3B
140K2	C7 ACERT	M315D	C4.4 ACERT	289D	C3.3B
140M	C9 ACERT	M315D2	C4.4 ACERT	297D2	C3.8
140M AWD	C9.3 ACERT	M316D	C6.6 ACERT	297D2 XHP	C3.8
140M2	C9.3 ACERT	M317D2	C4.4 ACERT	299D2	C3.8
140M2 AWD	C9.3 ACERT	M318D	C6.6 ACERT	299D2 XHP	C3.8
140M3	C9.3 ACERT	M318F	C7.1 ACERT		
140M3 AWD	C9.3 ACERT	M320D2	C7.1	<b>Backhoe Loaders</b>	
160K	C7 ACERT	M320F	C7.1 ACERT	416E	3054C
160M	C9 ACERT	M322D	C6.6 ACERT	416F	3054C, C4.4 ACERT
160M AWD	C9 ACERT	320D	C7.1 ACERT	420F	3054C, C4.4 ACERT
160M2	C9.3 ACERT	320D2 GC	C4.4 ACERT	430F	3054C, C4.4 ACERT
160M2 AWD	C9.3 ACERT	323D2	C7.1 ACERT	450F	3054C, C4.4 ACERT
160M3	C9.3 ACERT	320E	C6.6 ACERT	422F	3054C
160M3 AWD	C9.3 ACERT	320E RR	C6.6 ACERT	428F	3054C, C4.4 ACERT
14M3	C13 ACERT	320F	C4.4 ACERT	432F	3054C, C4.4 ACERT
16M3	C13 ACERT	323F	C7.1 ACERT	434F	3054C, C4.4 ACERT
18M3	C13 ACERT	323F N	C4.4 ACERT	444F	3054C, C4.4 ACERT
24M	C18 ACERT	325F	C4.4 ACERT		

¹ Meets Tier 4 Final/Stage IV/Japan 2014 (Tier 4 Final) emission standards.

² Meets Tier 3/Stage IIIA/Japan 2006 (Tier 3) equivalent emission standards.

## MACHINE/ENGINE CROSS REFERENCE (Continued)

Machine Model	Engine Model	Machine Model	Engine Model	Machine Model	Engine Model
<b>Pipelayers</b>		<b>Track Skidders</b>		<b>Articulated Trucks</b>	
PL61	C6.6 ACERT	517	3304TA	725	C11 ATAAC
PL72	C9.3 ACERT	527	3304TA	730	C11 ATAAC
PL83	C15 ACERT			730 Ejector	C11 ATAAC
PL87	C15 ACERT	<b>Forwarders</b>		735	C15 ATAAC
		564	C6.6 ACERT	740	C15 ATAAC
<b>Wheel Tractor-Scrapers</b>		574	C6.6 ACERT	740 Ejector	C15 ATAAC
621K, 623K, 627K Tractor	C13 ACERT	584	C7 ACERT		
627K Scraper	C9 ACERT	584HD	C7 ACERT	<b>Wheel Dozers</b>	
631K	C18 ACERT			814F <sup>4</sup>	3176C ATAAC
637K Tractor	C18 ACERT	<b>Track Feller Bunchers</b>		814F II <sup>3</sup>	C9 ACERT
637K Scraper	C9 ACERT	521B <sup>3</sup>	C9 ACERT	824H <sup>3</sup>	C15 ACERT
657G Tractor	C18 ACERT	522B <sup>3</sup>	C9 ACERT	824K <sup>1</sup>	C15 ACERT
657G Scraper	C15 ACERT	541 Series 2 <sup>3</sup>	C9 ACERT	834K	C18 ACERT
		552 Series 2 <sup>3</sup>	C9 ACERT	844K	C27 ACERT
				854K	C32 ACERT
<b>Forest Machines</b>		<b>Knuckleboom Loaders</b>		<b>Soil Compactors</b>	
320D Series 2 FM <sup>3</sup>	C7.1 ACERT	519 <sup>3</sup>	C6.6	815F II <sup>3</sup>	C9 ACERT
320D Series 2 FM LL <sup>3</sup>	C7.1 ACERT	529 <sup>3</sup>	C6.6	815K <sup>1</sup>	C7.1 ACERT
538 <sup>1</sup>	C7.1 ACERT	559C	C6.6 ACERT	825H <sup>3</sup>	C15 ACERT
538 LL <sup>1</sup>	C7.1 ACERT	569 <sup>3</sup>	C6.6	825K <sup>1</sup>	C15 ACERT
324D FM <sup>3</sup>	C7 ACERT	579C	C6.6 ACERT		
324D FM LL <sup>3</sup>	C7 ACERT			<b>Landfill Compactors</b>	
325D FM <sup>3</sup>	C7 ACERT	<b>Wheel Feller Bunchers</b>		816F	3176TA
325D FM LL <sup>3</sup>	C7 ACERT	553	C6.6 ACERT	816F II	C9 ACERT
558 LL <sup>1</sup>	C7.1 ACERT	563	C7 ACERT	826G Series II	3406E TA
568 <sup>2</sup>	C9.3 ACERT	573	C7 ACERT	<b>826H</b>	C15 ACERT
568 LL <sup>2</sup>	C9.3 ACERT			836G	3456TA
		<b>Mining &amp; Off-Highway Trucks</b>		836H	C18 ACERT
<b>Track Harvesters</b>		770G <sup>1</sup>	C15 ACERT		
501HD <sup>3</sup>	C6.6 ACERT	770G	C15 ACERT		
521B <sup>3</sup>	C9 ACERT	772G <sup>1</sup>	C18 ACERT		
522B <sup>3</sup>	C9 ACERT	772G	C18 ACERT		
541 Series 2 <sup>3</sup>	C9 ACERT	773G <sup>1</sup>	C27 ACERT		
552 Series 2 <sup>3</sup>	C9 ACERT	773G	C27 ACERT		
		775G <sup>1</sup>	C27 ACERT		
<b>Wheel Harvester</b>		775G	C27 ACERT		
550	C7 ACERT	777D	3508B (EUI) TA		
		777G <sup>1</sup>	C32 ACERT		
<b>Wheel Skidders</b>		777G	C32 ACERT		
525D	C7.1 ACERT	785C	3512B (EUI) TA		
535D	C7.1 ACERT	785D	3512C HD (EUI) ATAAC		
545D	C7.1 ACERT	789C	3516B (EUI) TA		
555D	C7.1 ACERT	793D	3516B (EUI) TA		
		793F	C175-16 (EUI) ATAAC		
		797F	C175-20 (EUI) ATAAC		

<sup>1</sup> Meets Tier 4 Final/Stage IV/Japan 2014 (Tier 4 Final) emission standards.<sup>2</sup> Meets Tier 4 Interim/Stage IIB/Japan 2011 (Tier 4 Interim) equivalent emission standards.<sup>3</sup> Meets Tier 3/Stage IIIA/Japan 2006 (Tier 3) equivalent emission standards.<sup>4</sup> Meets Tier 2/Stage II/Japan 2001 (Tier 2) equivalent emission standards.**NOTE:** All machines are not available in all regions. Contact your local Cat dealer for product availability.



# Tables

## MACHINE/ENGINE CROSS REFERENCE (Continued)

Machine Model	Engine Model	Machine Model	Engine Model	Machine Model	Engine Model
<b>Wheel Loaders/Integrated Toolcarriers</b>		<b>Track Loaders</b>		<b>Wheel Material Handlers</b>	
901C2 (Japan)	C1.8	953D	C6.6 ACERT	M318D MH	<b>C6.6 ACERT</b>
902C2 (Japan)	C2.4	953K	C7.1 ACERT	M322D MH	C6.6 ACERT
903C2	C2.4	963D	C6.6 ACERT	M325D MH	C7 ACERT
906K/M	C3.3B	963K	C7.1 ACERT	M325D LMH	C7 ACERT
907K/M	C3.3B	973C	C9 ATAAC	MH3037 <sup>3</sup>	C7.2 ACERT
908K/M	C3.3B			MH3037 <sup>1</sup>	C7.1 ACERT
910K/M	C4.4 ACERT	<b>Telehandlers</b>		MH3049	C9 ACERT
914K/M	C4.4 ACERT	TH255C <sup>2</sup>	TD2.9L	MH3059	C9 ACERT
918M	C4.4 ACERT	TH255C <sup>3</sup>	TD2.9L		
924K	C7.1 ACERT	TH336C <sup>2</sup> — Standard	C3.4B	<b>Track Material Handlers</b>	
926M <sup>1</sup>	C7.1 ACERT	TH336C <sup>2</sup> — Optional	C4.4 ACERT	385C MH	C18 ACERT
930K	C7.1 ACERT	TH336C <sup>3</sup> — Standard	C4.4 DITAAC		
930M <sup>1</sup>	C7.1 ACERT	TH337C <sup>2</sup> — Standard	C3.4B	<b>Paving Products</b>	
938K	C7.1 ACERT	TH337C <sup>2</sup> — Optional	C4.4 ACERT	<b>Cold Planers</b>	
938M <sup>1</sup>	C7.1 ACERT	TH337C <sup>3</sup> — Standard	C4.4 DITAAC	PM102	C7 ACERT
950 GC	C7.1 ACERT	TH406C <sup>2</sup> — Standard	C3.4B	PM620	C18 ACERT
950H	C7 ACERT	TH406C <sup>2</sup> — Optional	C4.4 ACERT	PM622	C18 ACERT
950K	C7.1 ACERT	TH406C <sup>3</sup> — Standard	C4.4 DITAAC		
950L	C7.1 ACERT	TH407C <sup>2</sup> — Standard	C3.4B	<b>Reclaimer/Soil Stabilizers</b>	
950M	C7.1 ACERT	TH407C <sup>2</sup> — Optional	C4.4 ACERT	RM300	C11 ACERT
962H	C7 ACERT	TH407C <sup>3</sup> — Standard	C4.4 DITAAC	RM500B	C15 ACERT
962K	C7.1 ACERT	TH414C <sup>2</sup>	C3.4B		
962L	C7.1 ACERT	TH414C <sup>3</sup>	C4.4 DITAAC	<b>Asphalt Pavers</b>	
962M	C7.1 ACERT	TH414C GC <sup>2</sup>	TDC3.6L4	AP255E	C2.2
966H	C11 ACERT	TH414C GC <sup>3</sup>	TDC3.6L4	AP300F	C3.3B
966K	C9.3 ACERT	TH417C <sup>2</sup>	C3.4B	AP355F	C3.3B
966L	C9.3 ACERT	TH417C <sup>3</sup>	C4.4 DITAAC	AP500F	C4.4 ACERT
966M	C9.3 ACERT	TH417C GC <sup>2</sup>	TDC3.6L4	AP555F	C4.4 ACERT
966M XE	C9.3 ACERT	TH417C GC <sup>3</sup>	TDC3.6L4	AP600F	C4.4 ACERT
972H	C13 ACERT	TH514C <sup>2</sup>	C3.4B	AP655F	C7.1 ACERT
972K	C9.3 ACERT	TH514C <sup>3</sup>	C4.4 DITAAC		C4.4 ACERT
972L	C9.3 ACERT	TL642C <sup>2</sup>	C3.4B		C7.1 ACERT
972M	C9.3 ACERT	TL642C <sup>3</sup>	C4.4 DITAAC	AP1000F	C7.1 ACERT
972M XE	C9.3 ACERT	TL943C <sup>2</sup>	C3.4B	AP1055F	C7.1 ACERT
980H	C15 ACERT	TL943C <sup>3</sup>	C4.4 DITAAC		
980K	C13 ACERT	TL1055C <sup>2</sup>	C4.4 ACERT		
980L	C13 ACERT	TL1055C <sup>3</sup>	C4.4 DITAAC		
980M	C13 ACERT	TL1055D <sup>1</sup>	C4.4		
982M	C13 ACERT	TL1055D <sup>3</sup>	C4.4		
986H	C15 ACERT	TL1255C <sup>2</sup>	C4.4 ACERT		
988K	C18 ACERT	TL1255C <sup>3</sup>	C4.4 DITAAC		
990K	C27 ACERT	TL1255D <sup>1</sup>	C4.4		
992K	C32 ACERT	TL1255D <sup>3</sup>	C4.4		
993K	C32 ACERT				
994K	3516E HD MUI				

<sup>1</sup> Meets Tier 4 Final/Stage IV/Japan 2014 (Tier 4 Final) emission standards.

<sup>2</sup> Meets Tier 4 Interim/Stage IIIB/Japan 2011 (Tier 4 Interim) equivalent emission standards.

<sup>3</sup> Meets Tier 3/Stage IIIA/Japan 2006 (Tier 3) equivalent emission standards.

## MACHINE/ENGINE CROSS REFERENCE (Continued)

Machine Model	Engine Model	Machine Model	Engine Model	Machine Model	Engine Model
<b>Paving Products (continued)</b>		<b>Paving Products (continued)</b>		<b>Underground Mining</b>	
<b>Single Drum Vibratory Soil Compactors</b>		<b>Double Drum and Combi</b>		R1300G	3306B DITA
CS34	C3.4B	CB14B	KDW1003	R1600H	C11 ACERT ATAAC
CP34	C3.4B	CB22B	KDW1003	R1700G	C11 ACERT ATAAC
CS423E	3054C	CB24B XT	C1.5	R2900G	C15 ACERT ATAAC
CS44	C4.4 ACERT	CC24B	C1.5	R3000H	C15 ACERT ATAAC
CP44	C4.4 ACERT	CB32B	C1.5	AD30	C15 ACERT ATAAC
CS44B	C3.4B	CB34B	C2.2	AD45B	C18 ACERT ATAAC
CP44B	C3.3B	CC34B	C2.2	AD55	C18 ACERT ATAAC
CS533E	3054C	CB36B	C2.2	AD60	C27 ACERT
CS533E XT	3054C	CB44B	C3.4B		
CP533E	3054C		C4.4 ACERT	<b>Hydraulic Mining Shovels</b>	
CS54B	C4.4B ACERT	CD44B	C3.4	6015B	C27 ACERT
CP54B	C4.4B ACERT		C4.4 ACERT	6020B	C32 ACERT
CS56B	C4.4B ACERT	CB46B	C3.4B	6030/6030 FS	2× C27 ACERT
	C6.6 ACERT	CB54B	C4.4 ACERT	6040/6040 FS	2× C32 ACERT
CP56B	C4.4B ACERT	CD54B	C3.4	6050/6050 FS	2× K1500E
	C6.6 ACERT	CB64B	C4.4 ACERT	6050/6050 FS <sup>1</sup>	2× QSK38
CS64B	C4.4B	CB66B	C4.4 ACERT	6060/6060 FS	2× 3512C
CS66B	C4.4B	CB68B	C4.4 ACERT	6090 FS	2× QSK60
CS68B	C4.4B ACERT				
	C6.6 ACERT	<b>Pneumatic Tire Compactors</b>			
CP68B	C4.4B ACERT	CW14	C3.4B		
	C6.6 ACERT	CW16	C3.4B		
CS74B	C4.4B ACERT		C4.4 ACERT		
	C6.6 ACERT	PS150C	3054C		
CP74B	C4.4B ACERT	CW34	C4.4 ACERT		
	C6.6 ACERT				
CS76B	C4.4B ACERT				
CS78B	C4.4B ACERT				
	C6.6 ACERT				
CS79B	C6.6 ACERT				

<sup>1</sup> Meets Tier 4 Interim/Stage IIIB/Japan 2011 (Tier 4 Interim) equivalent emission standards.

# Tables

## ENGINE/MACHINE CROSS REFERENCE

Engine Model and (Cylinders)	Machine	Aspiration	Fuel Injection System	Bore × Stroke		Displacement	
				mm	in	L	in <sup>3</sup>
3013C (3)	CB-214E, CB-224E, CB-225E	NA	DI	75 × 72	2.95 × 3.54	1.50	91.3
C1.3	303E	NA	DI	78 × 88	3.1 × 3.5	1.3	77
C1.7	303.5E2 CR	NA	DI	87 × 92.4	3.4 × 3.6	1.7	104
C1.8	303.5E, 901C2 (Japan)	NA	DI	87 × 102.4	3.4 × 4.0	1.8	111.4
C2.2	CB-334E, CB-335E, 216B3	NA	DI	84 × 100	3.31 × 3.94	2.22	135
	226B3, 226D	T					
C2.4	304E2 CR, 304.5E2 XTC, 305E2 CR, 305.5E2 CR, 902C2 (Japan), 903C2	NA	DI	87 × 102.4	3.4 × 4.0	2.4	146
	307E2, 306E2	T					
C2.6	307E, 307E2 (China)	T	DI	87 × 110	3.4 × 4.3	2.6	159.6
C3.3B	308E2 CR, 308E2 VAB, 906K/M, 907K/M, 908K/M, 236D, 242D, 246D, 257D, 259D, 262D, 277D, 279D, 287D, 289D	T	DI	94 × 120	3.7 × 4.7	3.3	203.3
C3.8	272D2, 272D2 XHP, 297D2, 297D2 XHP, 299D2, 299D2 XHP	T	DI	100 × 120	3.9 × 4.7	3.8	230
Yanmar 3TNV70	300.9D	NA	IDI	70 × 74	2.8 × 2.9	0.854	52.1
Yanmar 3TNV76	301.4C, 301.7D, 301.7D CR, 302.2D, 302.4D, 302.7D	NA	IDI	76 × 82	3.0 × 3.2	1.12	68.1
3046 (I-6)	D3G XL, D3G LGP, D4G XL, CS-533E, D4G LGP, D5G XL, D5G LGP, CP-533E, 315C/315C L*, 939C	NA	DI	94 × 120	3.7 × 4.7	5.0	305
		T	DI				
3054C (I-4)	416E, 416F, 420F, 430F, 450F, 422F, 428F, 432F, 434F, 444F	NA/T***	DI	105 × 127	4.13 × 5.0	4.4	268
3054C	312D2/312D2 L, 313D2	T	DI	105 × 127	4.13 × 5.0	4.4	268
	318D2 L	TA					
3054E (I-4)	CB-434D, CS-323C, CS-423E, CP-323C, PS-150C	NA	DI	105 × 127	4.13 × 5.0	4.4	268
	AP-800C, BG-230, BG-650, 908, PS-360B, PF-300B, PS-300B, CS-433E, CP-433E, CB-534C	T (optional)					
	M313C, M315C, AP-650B, 315C L**, BG-225C	TA					
3056 (I-6)	CS-563E, CS-573E, CS-583E, CS-663E, AP-655C, CS-683E, CP-563E, CP-573E, CP-583E, CP-663E, M316C, M318C, M322C	ATAAC	DI	100 × 127	3.94 × 5.0	6.0	365
3066 (I-6)	320C, 320C L, 320C LN, 320C S, 321C LCR	T	DI	102 × 130	4.0 × 5.1	6.4	391

\*Japan sourced.

\*\*France sourced.

\*\*\*Turbo optional on some models.

DI — Direct Injection

IDI — Indirect Injection

T — Turbocharged

TA — Turbocharged and Aftercooled

NA — Naturally Aspirated

ATAAC — Air/Air Aftercooled

**NOTE:** Materials and specifications subject to change without notice. Component commonality of Cat engines for all applications does not imply complete interchangeability. Contact your Cat dealer for specific information.

## ENGINE/MACHINE CROSS REFERENCE (Continued)

Engine Model and (Cylinders)	Machine	Aspiration	Fuel Injection System	Bore × Stroke		Displacement	
				mm	in	L	in³
3116 (I-6)	CB-634D, BG-240C, AP-900B	T	DI	105 × 127	4.13 × 5.0	6.6	402
	BG-260C, BG-245C, AP-1050B, AP-1055B, 120H STD, 135H STD, BG-2455C, AP-1000B	TA	DI				
3126 (I-6)	D5*, D6N*, 561N, 953C, 963C	T	DI	110 × 127	4.33 × 5.0	7.2	442
	525B, 535B	TA					
	325C LN	ATAAC					
3304 (I-4)	527, 517	TA	DI	121 × 152	4.75 × 6.0	7.0	425
C3.4B	311F L, 313F L GC	T	DI	99 × 110	3.90 × 4.33	3.4	207
C4.4 ACERT	D3K, D4K, D5K, D6K2, 416F, 420F, 430F, 450F, 428F, 432F, 434F, 444F, 910K/M, 914K/M, 918M	T	DI	105 × 127	4.13 × 5.0	4.4	268
	318D2 L, 320D2 GC	TA					
	312E, 313D2/313D2 L, 313D2 GC, 313F L, 314E/314E L, 315F L, 316E L, 316F L, 318F L, 320F, 323F N, 325F	ATAAC					
C6.6	R1300G II	ATAAC	DI	105 × 127	4.13 × 5.0	6.6	402
C6.6 ACERT	D6N, 953D, 963D, 120M, PL61, M318D MH, M322D MH, 120M, 120M AWD, 501HD, 320E, 320E RR	TA	DI	105 × 127	4.13 × 5.0	6.6	402
C7 ACERT (I-6)	950H, 962H, IT62H, M325D MH, M325D LMH, 120K, 120K2, 12K, 12M, 140K, 140K2, 140M, 160K, 324D FM², 324D FM LL², 325D FM², 325D FM LL²	ATAAC	DI	110 × 127	4.33 × 5.0	7.2	442
C7.1 ACERT	320D Series 2 FM², 320D Series 2 FM LL², 538¹, 538 LL¹, 558 LL¹, 924K, 926M¹, 930K, 930M¹, 938K, 938M¹, 950 GC, 950K, 950L, 950M, 962K, 962L, 962M, MH3037¹, 120M2, 120M2 AWD, D5R2, D5T, 953K, 963K, 320D2, 323D2, 326D2, 330D2, 326F, 330F, 335F	ATAAC	DI	105 × 135	4.1 × 5.3	7.01	427.8
C7.2 ACERT	MH3037²	ATAAC	DI	110 × 127	4.33 × 5.0	7.2	442
C9 ACERT (I-6)	336D2, 336D2 XE, 340D2, 814F II, 815F II, D6T, MH3049, MH3059, 521B, 522B, 541 Series 2, 552 Series 2	ATAAC	DI	112 × 149	4.4 × 5.9	8.8	537
C9 ACERT (I-6)	627G Sc., 637G Sc., 973C, 140M AWD, 160M, 160M AWD, D6R2, D7R	TA	DI	112 × 149	4.4 × 5.9	8.8	537

<sup>1</sup> Meets Tier 4 Final/Stage IV/Japan 2014 (Tier 4 Final) emission standards.

<sup>2</sup> Meets Tier 3/Stage IIIA/Japan 2006 (Tier 3) equivalent emission standards.

\*Not sold in U.S., Canada or Europe.

DI — Direct Injection

TA — Turbocharged and Aftercooled

T — Turbocharged

ATAAC — Air/Air Aftercooled

**NOTE:** Materials and specifications subject to change without notice. Component commonality of Cat engines for all applications does not imply complete interchangeability. Contact your Cat dealer for specific information.

## Tables

### ENGINE/MACHINE CROSS REFERENCE (Continued)

Engine Model and (Cylinders)	Machine	Aspiration	Fuel Injection System	Bore × Stroke		Displacement	
				mm	in	L	in <sup>3</sup>
3176 (I-6)	572R2, 345B L Series II, D7R, 814F, 815F, 816F	ATAAC	DI	125 × 140	4.92 × 5.5	10.2	629
C9.3 ACERT	D6T <sup>1</sup> , D7E, 568 <sup>2</sup> , 568 LL <sup>2</sup> , 966K, 966L, 966M, 966M XE, 972K, 972L, 972M, 972M XE, 336F, 336F XE, 12M2, 12M2 AWD, 12M3, 12M3 AWD, 140M2, 140M2 AWD, 140M3, 140M3 AWD, 160M2, 160M2 AWD, 160M3, 160M3 AWD, PL72	ATAAC	DI	115 × 149	4.53 × 5.87	9.3	567.5
3306 (I-6)	R1300G, 12H STD, 140H STD, 160H STD	T	DI	121 × 152	4.75 × 6.0	10.5	638
	D7G	TA	DI				
	545	ATAAC	DI				
3196 (I-6)	365B L Series II	ATAAC	DI	130 × 150	5.1 × 5.9	12.0	732
3406 (I-6)	RM-250C, RM-350B, D8R, D8R LGP	TA	DI	137 × 165	5.4 × 6.5	14.6	893
	826G Series II, 825G Series II, 824G Series II, AD30	ATAAC	DI				
C11 (I-6)	725, 730, 730 Ejector	ATAAC	DI	130 × 140	5.1 × 5.5	11.2	680
C11 ACERT (I-6)	R1600H, R1700G, 966H	TA	DI	130 × 140	5.12 × 5.51	11.1	680
		ATAAC					
C13 ACERT (I-6)	14M3, 16M3, 18M3, 349D2, 349F, 352F, 349F XE, 352F XE, 621K, 623K, 627K Tr, 972H, 980K, 980L, 980M, 982M	TA	DI	130 × 157	5.12 × 6.18	12.5	763
C15 ACERT (I-6)	D8T, D8T LGP, PL83, PL87, 657G Sc., 770G <sup>1</sup> , 770G, 986H, 374F	TA	DI	137 × 172	5.4 × 6.75	15.2	928
	R2900G, R3000H, AD30, 735, 740, 740 Ejector, 824K, 825K, 826H, 980H	ATAAC	DI	137 × 171.5	5.4 × 6.75	15.2	928
3456 (I-6)	834G, 836G, 988G, 385B, 385B L, 5090B	ATAAC	DI	140 × 171	5.5 × 6.75	15.8	966
3408 (V-8)	D9R, 589, PM-565B	TA	DI	137 × 152	5.4 × 6.0	18.0	1099
		ATAAC					
C18 ACERT	AD45B, AD55, D9T, 631G, 637G Tr., 657G Tr., 988H, 988K, 772G <sup>1</sup> , 772G, 834H, 834K, 836H, 385C MH, 24M, 390F	TA	DI	145 × 183	5.7 × 7.2	18.1	1106

<sup>1</sup> Meets Tier 4 Final/Stage IV/Japan 2014 (Tier 4 Final) emission standards.

<sup>2</sup> Meets Tier 4 Interim/Stage IIIB/Japan 2011 (Tier 4 Interim) equivalent emission standards.

DI — Direct Injection

TA — Turbocharged and Aftercooled

T — Turbocharged

ATAAC — Air/Air Aftercooled

**NOTE:** Materials and specifications subject to change without notice. Component commonality of Cat engines for all applications does not imply complete interchangeability. Contact your Cat dealer for specific information.





# TECHNOLOGY PRODUCTS

## CONTENTS

Introduction .....	31-1
Applications .....	31-3
Construction Technology:	
Cat® Connect.....	31-11
Mining Technology:	
Cat MineStar™.....	31-17

## INTRODUCTION

Caterpillar has long been a leader in bringing innovation to Cat products. Today, one of our biggest differentiators isn't just in our equipment — it's in the technologies we are integrating into our products that are improving machine performance and productivity, and transforming the way customers work to manage their operations and business more efficiently and cost effectively.

Caterpillar offers a range of technologies available on Cat equipment that can be customized to meet the needs of work sites in three primary industries:

- Construction
- Energy & Transportation
- Mining



**Construction Technology** products deliver dramatic improvements on the job site to help customers manage their business more efficiently and cost effectively. Fully integrated into Cat machines and core systems, these technologies use advanced electronics to accurately measure and control productivity, monitor and manage machine health and maintenance, and provide more insight into your equipment fleet and operation.

**Energy & Transportation Technology** products simplify equipment management to help customers monitor and manage assets, operate at peak performance, and lower operating costs.

**Cat Connect** combines the latest in technologies and dealer services to help customers improve in four key areas: Equipment Management, Productivity, Safety, and Sustainability to take optimum control of the job site. Whether running one machine, managing a fleet, or overseeing several job sites, Cat dealers can help customers with the right combination of technologies and services to meet the specific needs of their business and realize significant gains in productivity, efficiency and profitability.

- Cat Connect Technologies

- Cat GRADE
- Cat PAYLOAD
- Cat COMPACT
- Cat DETECT
- Cat LINK

- Cat Connect Services

- Equipment Management
- Productivity
- Safety
- Sustainability

**Mining Technology & Autonomy** products continue to have a positive impact on mining operations around the world. Caterpillar offers a complete suite of technology products purpose built for the harsh mining environment. Our products combine the latest GNSS positioning technology with sophisticated electronic controls and software to help miners increase productivity, monitor fleet health and lower operating costs.

**Cat MineStar** provides the most comprehensive suite of mining technology products in the industry. It consists of a number of configurable capability sets that allow you to scale the system to your mine site needs. Cat MineStar helps manage everything from material tracking to sophisticated real-time fleet management, machine health systems, autonomous equipment systems and more. The capability sets — Fleet, Terrain, Detect, Health and Command — can be used in combination or individually to allow your operations the flexibility and scalability it needs to be more productive, efficient and safe.

- Cat MineStar

- Fleet
- Terrain
- Detect
  - Vision
  - Object Detection
  - Proximity Awareness
  - Personnel
- Health
- Command
  - Command for dozing
  - Command for underground
  - Command for longwall

PRODUCT	CONSTRUCTION TECHNOLOGY APPLICATIONS	EQUIPMENT
Cat LINK Technology	<b>Cat LINK</b> enables you to remotely monitor and manage your equipment so you can reduce costs, increase job site efficiency, and effectively manage your business.	All types of equipment.
Product Link™	<b>Product Link</b> wirelessly connects you to your equipment giving you valuable insight into how your machine or fleet is performing. The system communicates location hours, fuel usage, productivity, idle time, and diagnostics codes. Available with cellular and satellite connectivity.	Standard on many types of Cat equipment. Retrofits available on Cat or mixed fleet equipment.
VisionLink®	<b>VisionLink</b> is a telematics software application that enables you to remotely monitor your equipment so that you can make timely, fact-based decisions to maximize efficiency, improve productivity, and lower the cost of owning and operating your fleet.	Standard on many types of Cat equipment. Retrofits available on Cat or mixed fleet equipment.
VIMS™	Provides operators, maintenance, and fleet managers with vital machine health and production information. VIMS Guardian, a retrofit product, excludes operator display and payload information.	VIMS is available on select Trucks, Track-Type Tractors, Wheel Loaders, Wheel Dozers, Motor Graders, and K Series 4-Drum Soil Compactors.
Cat GRADE Technology	<b>Cat GRADE</b> combines digital design data, in-cab guidance, and on some machines — automatic control — to help operators work more productively and accurately with less rework.	Select models of earthmoving, excavation, and paving equipment.
Cat AccuGrade™	<b>Cross Slope</b> systems are used for indicate-only guidance or to control one side of the blade to achieve accurate surface cross slope without any off-board infrastructure. This foundational system for motor graders can be combined with sonic, laser, GNSS or UTS technologies to make fine grading more efficient and productive. Machine mounted sensors are used to calculate necessary blade slope positioning. The system makes automatic adjustments to the left or right lift cylinder. The in-cab display delivers all of the cross slope information the operator needs to quickly and easily spread or cut material at the correct cross slope. The operator can select which side of the blade to control automatically and swap direction on the return pass without readjusting the settings. Elevation is controlled manually by matching grade or automatically by adding an elevation control device (sonic or laser). The cross slope systems are ideal for maintaining accurate cross slope over long distances without the need for infrastructure.	Motor Graders
	<b>Global Navigation Satellite Systems (GNSS)</b> use satellite technology to deliver precise 3D blade elevation and blade tip positioning information to the operator in the cab. Using machine-mounted components, an off-board GNSS base station and accuracy up to Real Time Kinematic (RTK) positioning, GNSS provides the information necessary for the system to accurately determine blade positioning with centimeter level accuracy. GNSS systems compute the positioning information on the machine compared to the position of the implement or machine relative to the design plane and delivers the information to the operator via an in-cab display. GNSS systems put all the information the operator needs to complete a job in the cab, resulting in a greater level of control. Provides precise location and elevation information for complex 3D contour applications, such as golf courses and highway super elevated curves.	Asphalt Compactors, Hydraulic Excavators, Motor Graders, Soil Compactors, Track-Type Tractors, Wheel Tractor-Scrapers, Landfill Compactors
	<b>Laser</b> systems provide precise 2D elevation control for grading with tight tolerances using a laser transmitter and receiver(s). A laser transmitter is set up on the work site to create a constant grade reference over the work area. A digital laser receiver is mounted on the blade of the machine and senses the laser signal as the machine moves across the work site. Laser systems are ideal for the fine grading on job sites with flat, single or dual slope surfaces, such as industrial, commercial or residential building sites.	Compact Track Loaders, Motor Graders, Multi Terrain Loaders, Skid Steer Loaders, Track-Type Tractors

PRODUCT	CONSTRUCTION TECHNOLOGY APPLICATIONS	EQUIPMENT
Cat AccuGrade	<p><b>Indicate-only</b> grade control systems for excavators provide in-cab guidance to indicate how much to cut or fill to achieve accurate grades and slopes. These systems can be combined with laser, GNSS or UTS technologies to make excavating more efficient and productive. Indicate-only systems provide the operator with precise real-time bucket positioning compared to an elevation reference to indicate how far the cutting edge is above or below desired grade. Using a combination of front linkage (stick, boom and bucket) sensors, the system calculates bucket tip position relative to a grade/survey stake or benchmark. When combined with a laser and receiver, the machine can travel after obtaining a reference benchmark from a laser transmitter to calculate the desired grade for elevation changes over large work sites, significantly increasing productivity. Indicate-only systems combined with laser are ideal for excavations, trenches, and general utility applications.</p>	Hydraulic Excavators
	<p><b>Sonic</b> systems provide 2D “elevation” control using an ultrasonic sensor to maintain accurate blade height. The system traces a previous pass, string line, or curb and gutter and uses the elevation as a reference. The grade control system calculates blade adjustments based on the reference and desired elevation and automatically moves the blade to achieve grade. The operator simply steers the machine to maintain the sonic tracer over the external reference. Sonic systems are ideal for controlling elevation in fine grading applications where curb and gutter or stringlines are used as references such as road construction and road maintenance.</p>	Motor Graders
	<p><b>Sonic, Contact and Slope Sensors</b> are combined to provide an elevation control system for paving and milling operations designed to control grade elevation and slope. The goal of grade and slope controls is to remove irregularities from the surface for maximum smoothness and control mat thickness for asphalt pavers and cutting depth for cold planers. The sonic system uses multiple transducers to provide an average of the reference surface while the contact sensor references the actual target to maintain the implement at the same relative vertical distance to an external reference such as a string line or a curb and gutter or even existing pavement. Slope Sensors complement these systems and are designed to control cross slope of the screed or cold planer. These sensors can work individually or together and make automatic elevation adjustments to maintain the appropriate targeted values. The operator simply steers the machine to maintain the sensor over the external reference and monitors the remaining job site variables to ensure a consistent product. Referencing beams are also available both as contact as well as non-contacting styles which help to provide better averaging of the existing surface to help customers achieve their smoothness targets.</p>	Asphalt Pavers, Cold Planers
	<p><b>Universal Total Station (UTS)</b> systems use high-accuracy, dynamic tracking technology on the job site to track a target mounted on the implement of the machine to determine the most precise 3D positioning. The system uses active target technology to reliably lock onto and track the intended target, eliminating false lock-ons to other active machine targets, survey crews or reflective surfaces. The UTS instrument continuously measures the target’s position and transmits real-time positioning data to the operator via the in-cab display, which shows the exact position of the implement in relation to the design. The system combines the position of the target with the known position of the implement, blade or tips, machine measurements and sensor outputs to calculate precise positioning of the blade tips. The system uses the positioning data to calculate desired elevation and cross slope. Cut and fill values are computed by comparing the positioning of the blade with the design file.</p>	Asphalt Pavers, Hydraulic Excavators, Motor Graders, Track-Type Tractors, Cold Planers

PRODUCT	CONSTRUCTION TECHNOLOGY APPLICATIONS	EQUIPMENT
Cat GRADE with Cross Slope	<p><b>Cross Slope</b> systems are used for indicate-only guidance or to control one side of the blade to achieve accurate surface cross slope without any off-board infrastructure. This foundational system for motor graders can be combined with sonic, laser, GNSS or UTS technologies to make fine grading more efficient and productive. Machine mounted sensors are used to calculate necessary blade slope positioning to achieve desired cross slope of the surface. The system makes automatic adjustments to the left or right lift cylinder, typically performed by the operator. Cat Grade Control Cross Slope systems are factory integrated and utilize the existing, standard machine display reducing the need for an additional grade control display for cross slope guidance. The in-cab display delivers all of the cross slope information the operator needs to quickly and easily spread or cut material at the correct cross slope. The operator can select which side of the blade to control automatically and swap direction on the return pass without readjusting the settings. Elevation is controlled manually by matching grade or automatically by adding an elevation control device (sonic or laser). The cross slope systems are ideal for maintaining accurate cross slope over long distances without the need for infrastructure.</p>	M Series, M2 and M3 Series Motor Graders
Cat GRADE with 3D	<p><b>3D</b> systems use Global Navigation Satellite System (GNSS) satellite technology to deliver precise blade positioning and location information to the operator in the cab. Using machine-mounted components, position sensing hydraulic cylinders, an off-board GNSS base station, and Real Time Kinematic (RTK) positioning accuracy, these systems provide the information necessary to determine precise blade positioning with centimeter level accuracy. The system computes the positioning information on the machine compared to the position of the cutting edge relative to the design plane and delivers the information to the operator via the standard in-cab display. All the information the operator needs to complete a job is delivered to the cab display, resulting in a greater level of control. Cat Grade Control 3D systems also provide overcut protection and linkage to additional Caterpillar exclusive features like AutoCarry™, Automatic Ripper Control and Load Assist. These systems are ideal for high production dozing and cutting complex 3D contours, such as highway projects.</p>	T Series Track-Type Tractors, H and K Series Wheel Tractor-Scrapers
Cat GRADE with Depth and Slope	<p>The <b>2D indicate-only</b> system for excavators provides the operator with precise real-time bucket positioning relative to the desired grade. Using a combination of position sensing hydraulic cylinders and sensors on the stick and boom pins, the system calculates bucket tip position relative to a grade/survey stake or benchmark. When used with the included laser receiver, the machine can reference a benchmark and travel while maintaining the elevation reference, even on uneven terrain. The laser receiver references the laser from a transmitter on the job site and calculates the desired grade for elevation changes, significantly increasing productivity. The factory-integrated system uses the existing machine display, reducing the need for an additional display. Sensors are deeply integrated and protected from damage in rugged applications. Cat Grade Control Depth and Slope is ideal for maintaining accurate grades and slopes in excavations and trenching applications.</p>	E and F Series Hydraulic Excavators

PRODUCT	CONSTRUCTION TECHNOLOGY APPLICATIONS	EQUIPMENT
Cat GRADE with Slope Assist	<p><b>Slope Assist</b> systems provide blade slope/angle control to the cutting edge to achieve accurate slopes with a quality surface finish in less time with less effort — without the need for off-board infrastructure. This integrated machine system uses a blade mounted sensor to calculate necessary blade slope position to achieve desired surface slope and main-fall. The system makes automated adjustments to the lift and tilt cylinders, typically performed by the operator. The in-cab display uses the existing machine display to deliver the information the operator needs to quickly and easily spread or cut material at the correct angle. Two modes are available: basic and advanced. Basic mode maintains the slope of the last given blade command. Advanced mode drives to and maintains a preset target slope. Elevation is controlled manually by matching grade or automatically by adding an elevation control device. This foundational system for dozers can be combined with laser, GNSS or UTS technologies to make grading even more efficient and productive.</p>	Select Track-Type Tractors
Cat GRADE and Slope	<p>The <b>Grade and Slope</b> system for asphalt pavers and cold planers utilize a combination of sonic, contact and slope sensors to provide an elevation control system for paving and milling operations designed to control grade elevation and slope. The goal of grade and slope controls is to remove irregularities from the surface for maximum smoothness and control mat thickness for asphalt pavers and cutting depth for cold planers. The sonic system uses multiple transducers to provide an average of the reference surface while the contact sensor references the actual target to maintain the implement at the same relative vertical distance to an external reference such as a string line or a curb and gutter or even existing pavement. Slope Sensors complement these systems and are designed to control cross slope of the screed or cold planer. These sensors can work individually or together and make automatic elevation adjustments to maintain the appropriate targeted values. The operator simply steers the machine to maintain the sensor over the external reference and monitors the remaining job site variables to ensure a consistent product. Referencing beams are also available both as contact as well as non-contacting styles which help to provide better averaging of the existing surface to help customers achieve their smoothness targets. Cat Grade and Slope for asphalt pavers includes vandal protection of the display boxes. Both asphalt pavers and cold planers come factory calibrated, utilize robust harnesses with strain relief components for excellent reliability and durability — a crucial element for paving applications.</p>	Asphalt Paver, Cold Planers
Cat COMPACT Technology	<p><b>Cat COMPACT</b> combines advanced compaction measurement, in-cab guidance and reporting capabilities to help consistently meet compaction targets faster, more uniformly, and in fewer passes — reducing rework and material costs in both soil and asphalt applications.</p>	Available on select Cat compactors.

PRODUCT	CONSTRUCTION TECHNOLOGY APPLICATIONS	EQUIPMENT
Cat COMPACT	<p>Compaction measurement is the foundation system for vibratory soil compactors. Compaction measurement is a real time indication of soil stiffness, provided by one of two available technologies: accelerometer based Compaction Meter Value (CMV) or Caterpillar exclusive energy based Machine Drive Power (MDP). The compaction measurement system outputs to the standard multipurpose display, providing the operator with real time data that helps them determine the state of compaction.</p> <p>The scalable compaction measurement system can be upgraded to include mapping. Mapping from the factory is an integrated SBAS accuracy GNSS which uses a satellite technology to deliver drum positioning information to the operator in the cab. The factory integrated design protects expensive and fragile components of the system from damage, theft or vandalism in a way that aftermarket systems cannot. The SBAS system from the factory does not require base stations or other off board hardware, but can be easily upgraded in the field with an AccuGrade RTK radio for greater accuracy. Mapping capability allows the operator to record and map compaction measurement values and pass counts, as well as other compaction application data for future analysis.</p> <p>Cat Compaction Control for asphalt compactors and the CW34 pneumatic tire roller provides mat temperature mapping and pass-count information to the operator, ensuring that compaction occurs at the optimum mat temperature and that uniform coverage is completed.</p>	B Series Vibratory Soil Compactors, K Series 4-Drum Soil Compactors, A and B Series Asphalt Compactors, CW34 Pneumatic Tire Roller
PAYLOAD Technology	<b>Cat PAYLOAD</b> enables accurate weight measurement of material being loaded or hauled. Payload information is shared with loader operators in real-time to improve productivity, reduce overloading and record both weights and number of loads per shift.	Available on select Cat wheel loaders, trucks, excavators and scrapers.
Cat PAYLOAD	<b>Cat PAYLOAD</b> provides on-the-go payload weighing through an in-cab LCD display so operators can deliver exact loads with confidence and work more efficiently. Operators can fill trucks to capacity without overloading, increasing productivity and eliminating costly fines. The system records detailed data to track productivity, including time/date, weights, cycles, and more. An optional in-cab printer enables operators to print individual load tickets as well as truck and material summary reports. Daily summary reports in the <i>VisionLink</i> web portal and detailed payload reports in <i>VIMSpC</i> software are available for productivity reporting and analysis.	H and K Series Wheel Loaders
Cat PAYLOAD with Production Measurement	<b>Production Measurement</b> brings on-the-go payload weighing to cab to help operators deliver exact loads with confidence and work more productively and accurately; without rework. The system is integrated at the factory into the standard cab display. Operators can track load weights in real time and know precisely how much material is in the bucket or truck. Instant payload feedback gives operators the confidence to know when loads are filled to target capacity, which reduces under and overloading, and maximizes the potential of the entire fleet. Payload information is stored in the display, enabling operators to track productivity such as weights, and totals per shift while in the cab. Productivity data can be accessed wirelessly through the <i>VisionLink</i> web portal giving the site supervisor a daily view of production totals and efficiency metrics.	M and K Series Wheel Loaders, C Series Articulated Trucks, F Series Excavators

PRODUCT	CONSTRUCTION TECHNOLOGY APPLICATIONS	EQUIPMENT
Cat PAYLOAD with Estimator	<b>Payload Estimator</b> uses bowl lift cylinder pressure on the loaded haul segment to calculate payload. This integrated system provides on-the-go payload weighing through the standard machine display so operators can deliver exact loads with confidence and work more efficiently. Deep integration ensures reliable operation and accurate data (within $\pm 5\%$ ). It is optimized to work with Sequence Assist or can be used in manual mode. Productivity data can be accessed wirelessly through VisionLink, giving the site supervisor a daily view of production totals.	H and K Series Wheel-Tractor Scrapers
Cat PAYLOAD with Truck Production Management System (TPMS)	<b>Truck Production Management System (TPMS)</b> enhances truck and loader effectiveness for improved fleet productivity and reduced operating cost. TPMS offers external lights or an optional digital display to signal the loading tool operator when the proper load is reached. The on-board system provides a payload accuracy of $\pm 5\%$ and stores payload weight, cycle segment times, cycle segment distance and fuel, operator ID and actual clock time and date of each cycle.	Off-Highway Trucks
Cat DETECT Technology	<b>Cat DETECT</b> combines safety and monitoring systems to enhance operator awareness. By expanding your view of the working environment around your equipment, you can improve the safety and productivity of your entire operation and keep your people and assets safe.	Available on many models of Cat equipment.
Cat DETECT with Rear Vision Camera	<b>Rear vision cameras</b> greatly enhance visibility behind the machine to help the operator work more productively. On many machines, the camera view is displayed through the standard display.	Standard on many types of Cat equipment. Retrofits available on most models.
Cat DETECT with Work Area Vision System (WAVS)	<b>Work Area Vision System (WAVS)</b> is used on larger equipment in applications where there are multiple machines, such as in a quarry. WAVS uses up to three cameras to provide full coverage in areas of limited visibility. Views can be set up by camera location (front, rear, side) or programmed to switch automatically based on direction of travel.	Optional on larger trucks and wheel loaders.
Cat DETECT with Tire Monitoring	<b>Tire Monitoring</b> uses sensors located on the rims to display tire pressures and temperatures on the in-cab monitor to help keep fleets running safely and productively. Operators can view real-time information via the Messenger display and work with confidence. Alerts enable operators to take immediate action before a tire failure occurs to reduce downtime. The system optimizes fuel consumption by operating at optimum tire pressures and reduces tire damage and frequent replacements due to high tire temperatures and under-inflation. Caterpillar designed and tested aftermarket kits work with multiple machine models and mixed fleets. Remote monitoring via VisionLink helps equipment managers schedule maintenance and make informed decisions.	All Cat and mixed fleet machines with tubeless tire rim sizes R29.5 and smaller.
Cat DETECT with Machine Security System (MSS)	<b>Machine Security System (MSS)</b> prevents unauthorized personnel from starting the machine by using a uniquely coded key that is programmed to a computer chip in the MSS module on-board the machine. The system can be set to prevent unauthorized use outside of normal working hours, and protect from vandalism or theft.	Standard on many types of Cat equipment.

PRODUCT	ENERGY & TRANSPORTATION TECHNOLOGY APPLICATIONS	EQUIPMENT
Energy & Transportation		
Product Link Web	Product Link Web provides features optimized for power systems equipment, including detailed engine parameters. An innovative tool for equipment management, the Product Link Web user-friendly interface enables communication between the customer and their equipment assets, and provides comprehensive information about the performance and condition of the equipment. It also enables the user to customize alerts so that critical operations can be prevented and or receive immediate attention.	Oil and Gas, Marine, Electric Power Generation, and Industrial installations
Cat AssetIQ™ Kits	AssetIQ Kits are field-installed solutions for collecting engine data and information on Cat or other manufacturers' mechanical or basic electronic equipment. Kits are available for Fuel Flow Monitoring Systems and Sensor Kits for basic engines and genset applications.	Oil and Gas, Marine, Electric Power Generation, and Industrial installations

PRODUCT	MINING TECHNOLOGY & AUTONOMY APPLICATIONS	EQUIPMENT
Cat MineStar		
Fleet	Fleet is a comprehensive mine management system featuring an advanced truck assignment engine, health and operational event alarming, "what-if" analysis, productivity tracking, machine tracking, material management and a comprehensive reporting package. Integrating with other Cat MineStar capability sets, Fleet improves productivity by 10-15%, eliminates misdirected loads, improves information availability and provides greater flexibility to adjust for changing mine and market conditions.	Entire mining fleet
Terrain	Terrain for drilling increases hole placement and depth accuracy while removing the cost of drill pattern survey and staking. Position and status information of other drills working on the same pattern is provided to operators in real time on the in-cab display. Terrain for draglines enables production monitoring of all dragline activities, right down to individual bucket loads and dump locations. Machine performance, productivity and payload are monitored and organized in reports to optimize dragline output and minimize operating costs. Terrain for grading ensures accurate execution of the design plan and enables safe operating practices. It can be used on a variety of machines in numerous applications from production dozing to reclamation, all helping you mine more safely and productively. Terrain for loading provides accurate information on each pass helping operators to move the right amount of material with every bucket load. Safety, productivity and efficiency are positively impacted and the mine design plan accurately executed.	Blasthole Drills, Articulated Drills, Draglines, Scrapers, Loaders, Dozers, Shovels, Motor Graders, Hydraulic Excavators, Track-Type Tractors, Surface Miners, Terrain Levelers



PRODUCT	MINING TECHNOLOGY & AUTONOMY APPLICATIONS	EQUIPMENT
<b>Cat MineStar</b>		
Detect	<p>Vision is a camera system available on mobile surface equipment and underground longwall systems. It provides multiple camera views that improve the operator’s awareness of the vicinity around working equipment.</p>	<p>Surface: Select models of Electric Rope Shovels, Hydraulic Shovels, Off-Highway Trucks, Medium Wheel Loaders, Large Wheel Loaders, Large Motor Graders, Medium Wheel Dozers, Large Wheel Dozers Underground: Longwall Systems</p>
	<p>Object Detection uses cameras and radars to improve the operator’s view of key areas around the machine, allowing operators to make informed decisions. The system works with several machine types increasing machine perimeter awareness during critical periods including startup, initial movement and reverse travel. The system consists of an interactive touch screen display, radars and cameras on the front, rear and sides of the machine. Radar and camera configuration will vary by machine type.</p>	<p>Select models of Off-Highway Trucks, Medium Wheel Loaders, Large Wheel Loaders, Large Motor Graders, Medium Wheel Dozers, Large Wheel Dozers</p>
	<p>Proximity Awareness is a GNSS based system which tracks machines and light vehicles, allowing operators to view other machine locations and provide proximity based alarming. The system alerts operators based on speeding violations, hazards and avoidance zone entry. Office software allows mine managers to capture incidents for playback and reconstruction. Proximity Awareness is active whenever the machine is in operation providing complete coverage.</p>	<p>Entire mining fleet</p>
	<p>Personnel uses locator tags that indicate each person’s location and proximity to moving equipment. When a roof support is given a command to advance on a longwall face and a tag is detected as being in “harm’s way,” the roof support won’t advance until that person has moved a safe distance away.</p>	<p>Longwall Systems</p>
	<p>A Fatigue Risk Management System helps manage unseen risk factors that impact customer operations daily. On-machine technology gives the power to visualize and quantify the prevalence of fatigue and distraction events in conjunction with Caterpillar experts that help mines make immediate improvements and create a long-term plan for performance excellence.</p>	<p>Site level solution</p>
Health	<p>Health delivers critical event-based equipment condition and operating data for your entire fleet. It includes comprehensive, proactive health and asset monitoring capabilities, with a wide range of diagnostic, reporting tools, analytics and recommendations.</p>	<p>Cat mining equipment and select models of other brands of mining machines</p>
Command	<p>Command for underground is designed to enhance safety and boost operator efficiency and effectiveness. The system allows the operator to work from a safe and ergonomic work station far from the Load Haul Dump (LHD) machine — either on the surface or underground without sacrificing machine productivity. The system can also have a significant impact through increased machine availability, decreased operating costs and extended machine life.</p>	<p>Available as an attachment for select models of Hard Rock Underground Mining Loaders</p>
	<p>Command for longwall offers semi-autonomous control for Cat plows. Automation of steering and shield movement, along with plow automation no longer require operators to be at the working face, enhancing safety.</p>	<p>Cat Plows</p>
	<p>Command for dozing enables remote operation from a safe location away from the machine. Removing operators from the cab of a machine working in hazardous conditions promotes safety and reduces operator exposure to dust, noise and vibration. Command for dozing can utilize either an over the shoulder operator console or a seated operator station for longer term operations. Either system utilizes line of sight communications for distances up to 400 m (1312 ft) depending on conditions. Terrain’s avoidance zone functionality (optional) can be utilized to further enhance safety.</p>	<p>D10T, D11T, D11T CD Track-Type Tractors</p>

## CAT CONNECT

Cat Connect combines the latest in construction technologies and services to help customers improve in four key areas: Equipment Management, Productivity, Safety, and Sustainability. Because every job site has its own unique challenges — whether running one machine, managing a fleet, or overseeing several job sites — Cat Connect enables customers to combine technologies and services in ways that make the most sense for their business and realize significant gains in productivity, efficiency and profitability.

### Cat Connect offers the following technologies:

- LINK
- GRADE
- COMPACT
- PAYLOAD
- DETECT

### Cat Connect offers the following services:

- Cat EMSolutions™
- Caterpillar Fleet Monitoring Center
- Productivity Services
- Job Site Solutions
- Safety Services

## Cat LINK Technology

Cat LINK connects you to your assets (people or equipment) giving you access to essential information you need to know to run your business. Cat LINK data can give you valuable insight into how your machine or fleet is performing so you can make timely, fact-based decisions that can boost job site efficiency and productivity.

### Product Link

Product Link is the combination of GPS and telecommunications hardware used to communicate information about your assets so you can remotely monitor it. The GPS pinpoints the location while the integrated cellular or satellite radio enables data to be transmitted from many locations across the world. The data flows securely to the data servers at Caterpillar and then redistributed to you.

For Cat equipment, Product Link is designed as a factory standard or retrofit option for many models delivered to more than 50 countries. It is deeply integrated with engine, transmission and implement control systems to help you take the guesswork out of equipment management. Easy access to timely information can help you effectively manage your fleet and lower operating costs.

For other equipment brands, Product Link can communicate basic information – location, data derived from switches and switch inputs, and publicly available data on the other manufactures CAN bus.

The Product Link family provides you the ability to select the right fit options for your fleet operations.

**VisionLink**

VisionLink is a telematics software application that allows registered users to securely access information critical to their fleet and job site operations to:

- Manage assets using site boundaries, asset groups, shared asset views, etc.
- Manage scheduled maintenance, custom maintenance intervals, and major components.
- Monitor equipment health by monitoring fault codes, fluid analysis, tire monitoring and inspections.
- Maximize asset utilization and efficiency.
- Manage load counts.
- Create email or SMS alerts to remotely manage your fleet.
- Track payload data and fuel burn rates.
- Create reports
- Share data from or to other systems, i.e. ERP like SAP, accounting, or payroll.

Consult your dealer's Product Link specialist for more details or visit [cat.com/PL](http://cat.com/PL) or [LINK](http://cat.com/LINK).

**VIMS**

VIMS is a fully integrated technology solution that uses sensors located throughout the machine to monitor crucial machine health, performance and productivity information. VIMS captures detailed, up-to-the minute data and displays it for the operator in real-time. The system alerts operators of abnormal machine conditions and provides instructions if action is needed. Data, such as historical trends, histograms, events and more can be transferred wirelessly or manually to the office for off-board analysis. VIMS PC software and the Health module within the Cat MineStar are predictive analysis tools used to analyze and interpret the data and provide reports that provide actionable information for informed decision making on machine performance, productivity issues, operations improvements, and fleet management. (Available data varies by machine model and type.)

**Value of VIMS**

- For the machine operator VIMS establishes two-way communication between the operator and the machine. Real-time machine information allows the operator to make informed decisions that directly affect safety, machine availability, and maximize productivity.
- For maintenance VIMS provides an in-depth view of operator and machine performance. This allows maintenance managers and technicians to maximize component life, reduce catastrophic failures, minimize unscheduled downtime and improve asset management.
- For production VIMS collects the information needed to monitor equipment usage, personnel performance, and productivity levels. Payload information can be used as an accounting tool, an indicator of cycle time efficiency and truck overloading or under loading.

## Cat GRADE Technology

Cat GRADE combines digital design data, in-cab guidance, and automatic controls to enhance grading accuracy, reduce rework, and lower costs related to paving and earthmoving in rough, fine and finish grade applications.

Cat GRADE increases increase productivity by moving material right the first time and achieving accurate grades without rework. These systems compute and track the location of the bucket or blade and compare this information with design parameters to guide to the operator to grade. In-cab displays with easy-to-use operator interface provide grade information in real time. Basic systems provide indicate-only information, while more enhanced systems can signal the machine hydraulics to move the blade to the desired design automatically. Cat GRADE increases productivity, improves performance for less experienced operators, reduces operator fatigue, and enhances overall job site safety.

Cat GRADE offers customers these advantages and cost-savings:

- Increase productivity
- Reduce fuel savings
- Reduce guesswork and costly rework
- Reduce survey costs
- Reduce staking, string lines and grade-checkers
- Increase material utilization
- Reduce owning and operating costs
- Reduce labor requirements and costs
- Finish jobs faster
- Work more confidently
- Extend the work day

Many aftermarket systems exist in the market today, but no system designed by someone other than the OEM can bring the advantages that integration makes possible.

Depending on the machine family and the specific application, many of the components necessary for automation are already present on a Cat machine. Cat GRADE leverages these components and optimizes the design as only Caterpillar can. Whether it is a sensor, cylinder, display or software, Cat GRADE integration is designed to reduce redundant components, protect sensors and allow productivity features to work together.

Cat GRADE integrates traditional grade control with machine hardware and software in the factory to improve productivity, usability, reliability, job site safety and machine value. It is another example of Caterpillar innovation and technology leading the way for our customers to be more successful.

### **Cat GRADE technology is comprised of the following:**

- Cross Slope
- 3D
- Depth and Slope
- Slope Assist
- Grade and Slope

### Cat COMPACT Technology

Cat COMPACT combines advanced compaction measurement, in-cab guidance and reporting capabilities to help you consistently meet compaction targets faster, more uniformly, and in fewer passes — reducing rework and material costs in both soil and asphalt applications.

Compaction is one of the most critical steps in the construction and road building process. Successful projects rely on achieving target compaction to stringent design specifications to ensure structural stability of the finished product.

Asphalt compaction technologies display mat temperature in the cab, indicating when and where operators need to work to quickly achieve consistent quality results. The system measures mat temperatures in real time, indicating the approach of tender zones and where the operator can work productively.

Soil compaction technologies give operators the information and instant feedback they need to achieve uniform results with maximum efficiency. Plus, it helps to identify hidden soil problems that can affect compaction quality.

Cat COMPACT offers customers these advantages and cost-savings:

- Increase productivity
- Reduce fuel savings
- Reduce guesswork and costly rework
- Increase material utilization
- Reduce owning and operating costs
- Reduce labor requirements and costs
- Provide Quality Control/Quality Assurance Documentation
- Finish jobs faster
- Work more confidently
- Extend the work day

Cat COMPACT provides information about the state of compaction to operators. The optional system comes with a choice of two different measurement technologies, Compaction Meter Value (CMV) and Machine Drive Power (MDP). CMV is an accelerometer-based system that displays a compaction value that indicates compaction quality. CMV is for smooth drum machines only and works well in granular applications and thick lifts. It is a Caterpillar exclusive technology that measures rolling resistance — with the vibratory system on or off — and correlates it with soil stiffness. MDP is for smooth and padfoot drums and works well in both cohesive or granular soils.

Optional 3D Mapping enables temperature or compaction measurements to be mapped to the precise location the operator is working, providing a real time view of progress. Mapping data is recorded to document compaction uniformity and job completion.

#### Cat COMPACT technology uses the following:

- Compaction Meter Value (CMV)
- Machine Drive Power (MDP)
- GNSS (SBAS)

### Cat AccuGrade

Cat AccuGrade systems are dealer installed technologies that can be used to guide an operator to grade, manually using in-cab guidance, or automatically by controlling the blade movements to help operators get to grade faster, and more accurately. The systems use machine mounted sensors to calculate precise blade/tool location, slope and/or elevation information. The integrated electrohydraulic valve control module uses the information received from the sensors to control the machine's hydraulic system and automatically adjust the blade's cutting edge to maintain grade on select machines. Depending on the configuration, the operator can select which side of the blade/tool to control — right, left, or both sides. AccuGrade brings to the customer an increase in productivity by up to 40% while reducing their site costs dramatically.

#### Cat AccuGrade technologies include:

- Cross slope
- Sonic
- Site Reference
- Laser
- GNSS
- UTS

### Cat PAYLOAD

Cat PAYLOAD enables accurate weight measurement of material being loaded or hauled. Payload information is shared with loader operators in real-time to improve productivity, reduce overloading and record both weights and number of loads per shift.

- Production Measurement
- Payload Estimator
- Truck Production Management System (TPMS)

**Cat Production Measurement** for Wheel Loaders, Excavators, and Articulated trucks is integrated from the factory and brings payload weighing to the cab to help operators work more productively and accurately; without rework. Operators can track load weights in real time on the in-cab monitor and know precisely how much material is in the bucket or truck. The system uses data from a series of onboard sensors that is processed by the onboard computer to calculate payload weight. Instant payload feedback through the display gives operators the confidence to work more efficiently and know when loads are filled to target capacity. Truck system also features external payload lights to indicate when the load is full.

**Payload Estimator** for Scrapers uses bowl lift cylinder pressure during the loaded haul segment to calculate payload. When working in manual operation, the system is optimized to work with Sequence Assist for increased productivity with less effort. Deep integration ensures reliable operation and accurate data (within  $\pm 5\%$ ).

Cat PAYLOAD maximizes the potential of the entire fleet:

- Enables operators to consistently fill to target payload
- Reduces under loading that reduces productivity, increases haul cycles, fuel usage, and operating costs
- Allows operators to track productivity such as weights and totals per shift
- Reduces overloading that can cause excessive wear on equipment and haul roads and lead to safety concerns

**Truck Production Management System (TPMS)** enhances truck and loader effectiveness to improve fleet productivity and reduce operating costs. TPMS offers external lights or an optional digital display to signal the loading tool operator when the proper load is reached. The on-board system provides a payload accuracy of  $\pm 5\%$  and stores payload weight, cycle segment times, cycle segment distance and fuel, operator ID and actual clock time and date of each cycle.

**Cat DETECT Technology**

**Cat DETECT** combines safety and monitoring systems to enhance operator awareness. By expanding your view of the working environment around your equipment, you can improve the safety and productivity of your entire operation and keep your people and assets safe.

- Rear Vision cameras
- Work Area Vision System (WAVS)
- Tire Monitoring
- Machine Security System (MSS)

**Rear vision cameras** greatly enhance visibility behind the machine to help the operator work more productively. On many machines, the camera view is displayed through the standard display.

**Work Area Vision System (WAVS)** is used on larger equipment in applications where there are multiple machines, such as in a quarry. WAVS uses up to three cameras to provide full coverage in areas of limited visibility. Views can be set up by camera location (front, rear, side) or programmed to switch automatically based on direction of travel.

**Tire Monitoring** enables operators to monitor tire pressures and temperatures on the in-cab monitor. Alerts enable operators to take immediate action before a tire failure occurs and avoid unsafe operation.

**Machine Security System (MSS)** prevents unauthorized personnel from starting the machine by using a uniquely coded key that is programmed to a computer chip in the MSS module on-board the machine. The system can be set to prevent unauthorized use outside of normal working hours, and protect from vandalism or theft.

## CAT MINESTAR

Cat MineStar is a comprehensive suite of technologies that allows you to see your entire operation at a glance, then drill down to the individual asset level as required. Its capability sets — Fleet, Terrain, Detect, Health and Command — enable you to define the size and scope of your management system based on the needs of your mining operation.

For more information on Mining Technology & Autonomy products, visit [cat.com/minestar](http://cat.com/minestar).

### Fleet

With real-time machine tracking, assignment and productivity management, Fleet gives you a comprehensive overview of all your operations. Fleet enhances the management of all types of equipment operations and allows you to easily drill down for more detailed views and analysis. You can generate reporting on selectable groups of assets, equipment on a particular site or even individual machines.

Fleet works with data from all types of assets and equipment — including off-highway trucks, wheel loaders, motor graders, wheel dozers, shovels, light duty vehicles and equipment from other manufacturers — helping you reduce costs per ton, enhance productivity and boost overall site profitability.

Fleet is comprised of five capability packages, which can be purchased and configured based on a mine's particular needs.

- **Production** — Provides real-time visibility of production operations, delivers improved shovel loading performance and increases payload predictability.
- **Position & Material** — Monitors material movement and type, alerts operators and planners of misroutes to ensure material is moved to the proper location. Also monitors machine location for the entire fleet and incorporates playback function to analyze dump movement and haul road congestion.
- **Assignment & Optimization** — Schedules and assigns equipment, maximizes production and shovel utilization, minimizes truck wait time and manages shift changes and fueling.
- **Data Share** — Allows Fleet to share data made available via the licensed capability packages with other applications such as data reporting systems and position monitoring systems via an industry standard interface.



Fleet provides a proven solution suite based on a single trusted set of data for real-time KPI and for standard and ad-hoc reports. It provides the mine with information to:

- Identify and quantify performance improvement opportunities (within and post shift)
- Develop strategies to capture performance improvement initiatives
- Assign equipment and fleets for maximized production or achievement of material management goals. Capability scales from simple assignment to full truck assignment with linear programming to ensure maximal flexible loader, truck and material capacity utilization
- Blend materials in order to meet preparation plant quality, tonnage and timing requirements
- Track machines and materials to ensure correct delivery of materials from sources to planned sinks and to monitor equipment routing
- Manage operators (licensing, shift allocation and rostering)
- Manage equipment fluids and tires
- Track equipment productivity capability, consumption and variance
- Monitor equipment health including alarms and sensor channel monitoring, pre-start checklists
- Determine “what if” impacts of making specific changes to the product plan

Cost reduction of 10% and greater can be achieved and sustained using Fleet. Cost reductions are typically realized through reduced equipment, manning, lower fuel and service requirements, while achieving the same levels of productivity.

### Terrain

Terrain enables high-precision management of drilling, dragline, grading and loading operations through the use of advanced guidance technology. It increases machine productivity and provides you real-time feedback for improved efficiency.

Along with providing detailed in-cab machine guidance and machine positional information for equipment operators, Terrain makes a wealth of data available to mine managers and site planners — including up-to-the-minute machine location and operational status, progress toward completion of work plans and more.

Terrain gives machine operators the real-time guidance they need to do their jobs more safely and efficiently, while providing mine site managers with timely information and advanced tools to help them increase mine productivity, output production and profitability.

### Terrain capability packages include:

- **Productivity** — Productivity allows the mine to track and analyze machine utilization and productivity by machine type and operator. Reporting tools generate information on machine utilization, timelines, operator productivity and other parameters to help identify and correct operational inefficiencies. It also enables the assignment of job tasks to grading and loading tools. Operators can even request the creation and assignment of a task to another operator (such as clean-up a spill). The information about each task is tracked and stored for reporting purposes.
- **Position & Material** — The Position & Material capability package allows machines to share position and job status information both on-board and in the office. This knowledge helps reinforce safe operating practices when working in close proximity. The Position & Material capability package also enables machine-to-machine cut and fill status sharing within grading and loading applications in real-time including sharing cut/fill information from draglines to dozers.

- **Data Share** — Allows Terrain to share data made available via the licensed capability packages with other applications such as competitive fleet management systems, data reporting systems, and position monitoring systems via an industry standard interface.
- **Multi-Site** — Allows for management of multiple Terrain-equipped sites from a single control center. By licensing the optional Multi-Site package at each mine, customers can monitor and manage work activities for multiple mines based on their universally defined user access permissions.

### Terrain for Drilling

Terrain for drilling is designed for installation on electric, hydraulic rotary blasthole, and articulated drills. It provides production and performance monitoring, strata recognition and GNSS guidance. Provided as a field retrofit to machines already operating at mine sites, Terrain uses on-board computing integrated with sensors to monitor critical machine performance characteristics. System modules help the operator and site managers enhance drill performance and improve the drilling and blasting operation.

Production offers a graphical user interface to provide the operator with immediate feedback on drilling productivity and performance. The product minimizes operator input by an array of sensing hardware to detect:

- Hole depth
- Reaching target depth
- Steel changes

Strata Recognition analyzes the monitored drilling variables in real-time, determining variability in the hole geology. The different strata horizons are presented on the display. The system provides useful and concise information from the start of drilling — not large amounts of raw data that typify traditional drill monitoring systems. A Blastability Index is determined by the Strata Module and approximates the hardness of the ground. The hole loading requirements and ore grindability predictions are then based on measured rock hardness enabling improved blending and optimized mill through put rates.

### Combining Production with Strata Recognition logs:

- Bit rotary speed
- Penetration rate
- Depth
- Rotary torque or pressure
- Pull-down pressure
- Bailing air pressure

Drilling practice, efficiency and productivity can then be analyzed and assessed.

Guidance adds high precision GNSS to help precisely position a drill on a blast pattern without the need for surveying or staking. Guidance uses a moving map display that shows the 3D (Northing, Easting and Elevation) of the drill and drill bit relative to the designed position of the blastholes. Once the drill is positioned and leveled over a hole, the system automatically determines collar elevation and then calculates the designed target depth. Guidance improves the drill's production and utilization, and the operator's ability to drill to the plan. This leads to better rock fragmentation for easier loading. Since holes are drilled to the correct elevation leading to a flatter post-blast surface, the result is smoother pit floors. This helps eliminate rework, enhances the mobile equipment's performance and reduces its wear and tear.

### Terrain for Draglines

Terrain for Dragline provides real-time monitoring and reporting of dragline operations. By combining GNSS and production monitoring data, the system empowers the mining office to plan and control operations. It records the complete, detailed data associated with each load cycle.

The system gives the operator the design plan and real-time position of the dragline relative to the plan in 3D. It also monitors, displays, and logs various parameters from the machine and site.

- **Production Monitoring** — Production Monitoring provides real-time tracking and reporting of dragline operation results. When coupled with GNSS, Production Monitoring empowers miners to plan and control operations. The unparalleled geo-referenced production monitoring capability also records detailed data for subsequent analysis and reporting. Unlike traditional monitoring systems, Terrain for draglines records the complete, detailed data associated with each load cycle. The cycle data is not averaged or filtered, which means that the full data set remains available for additional querying.
- **3D Bucket Positioning** — This feature expands the basic GNSS navigation and Production Monitoring to provide the operator with a plan and profile view of the dragline and cut being excavated. The profile view can also include the bench, cut, beginning locations and final locations.
- **Load Weighment** — Terrain for draglines determines the payload weight during the swing to dump cycle. The load weighment feature calculates running and total shift productivity in actual tons in addition to a theoretical volume. Accurate payload information allows for a more precise measure of true machine productivity.
- **Boom Stress Monitoring** — Boom failure is a catastrophic event for a dragline. Terrain for draglines interfaces with third party boom stress monitoring systems to display information that the operator can use to minimize boom stress. Time-stamped data is recorded and logged enabling the mine office to manage boom life and operational practices.

### Terrain for Grading & Loading

Terrain for grading & loading moves the material identification file and survey system into the machine, eliminating the need for survey stakes or pin flags. A touch screen monitor displays the location of pit boundaries, material type, bench height, and design grade, eliminating operator guesswork. With material types and locations displayed, ore identification and recovery are optimized.

The system is an ideal tool for mine planning, engineering, surveying, grade control and production monitoring applications. For example it can be used for:

- Haul road and bench construction and maintenance
- Production dozing
- Leach pad construction and maintenance
- Reclamation
- Task List Management
- Ore grade control and material identification
- Coal load out terminals

The system can be used on scrapers, loaders, dozers, shovels, motor graders, hydraulic excavators and track-type tractors.

Terrain features a mobile application for use in light vehicles. Mine supervisors can log in from a laptop or tablet to view progress updates from nearby machines, know the precise location of all Terrain-equipped machines, assign tasks and validate design plans without having to drive back to the mine office, improving the efficiency of your operations. Updates made on the mobile application are sent back to the office software and then communicated to the applicable machine on-board system in near real-time.

## Detect

Operators often cannot see if another machine or vehicle is too close for safe operation. Detect helps alleviate this potential safety hazard and can also be configured to provide valuable information about site conditions and other assets working in the area.

At the most basic level, Detect enhances your operators' awareness of the immediate environment around their equipment. A simple touch screen display alerts operators when radars indicate that objects have entered critical areas near the machine. The system allows a quick visual check of these areas whenever the operator wants one.

Additional capability packages enable Detect to alert the operator to pre-programmed avoidance zones, known site hazards and speed limits. Positional information from Detect can also provide valuable feedback to central office systems and mine site managers.

### Detect capability packages include:

- **Vision** — Vision offers multiple camera capabilities, allowing operators to select the view or views they need on the in-cab display to see what is happening close to their machines.
- **Object Detection** — Object Detection adds radars while reducing areas of limited visibility and increasing perimeter awareness. This robust system is scalable to site needs and machine types, providing optimal awareness around equipment.
- **Proximity Awareness** — Proximity Awareness adds GNSS capabilities allowing Detect to display the locations of other equipment at all times. It also allows pre-programmed information — such as avoidance zones, hazards and speed limits — to be displayed in the cab. Incidents are captured in the office and are available for reporting and playback.
- **Personnel** — Personnel enhances safety of longwall operations through the use of locator tags. Individuals wearing tags are identified via programmed information such as ID and job role. The tags work with the roof support control system to stop movement if the presence of a tagged individual is in close proximity to moving equipment.

## Vision

Vision for surface equipment offers multiple camera capabilities, allowing operators to manually select the view or views they need on the in-cab display to see what is happening close to their machines. Certain Vision kits are configurable for manual or rotating camera views. In underground applications, cameras are able to identify people and can follow them as they move along the working face. Built-in intelligence capabilities enable the system to span multiple cameras and combine images to create a continuous, real-time view of tracked personnel.

### Object Detection

Object Detection is designed for machines ranging from large mining and quarry trucks to machines such as wheel loaders and motor graders. This robust system builds on Vision by adding radars to provide optimal awareness around the machine and notification when an object is detected. With both audible and visual indications, Object Detection helps prevent work area injuries caused by limited awareness. Using a combination of radars, cameras, and a high-resolution touch screen display, operators can view the areas immediately surrounding their machine, helping to prevent collisions and accidents.

Object Detection is highly integrated with the specific machine configuration to optimize radar and camera coverage. The system has been calibrated to provide appropriate fields of view and range. Unlike basic camera systems, Object Detection provides operators with audible and visual types of warnings that enable the operator to make informed decisions when moving or operating the machine. This system alerts the operator when an object is in close proximity so they can decide if action needs to be taken to avoid it.

### Proximity Awareness

Proximity Awareness is a GNSS based system which tracks machines and light vehicles, allowing operators to view other machine locations and provide proximity based alarming.

The system is highly configurable allowing customers to define areas around the machine along with values that determine projected path of travel. Filters can be set to reduce alarming where machines naturally come in close proximity as part of their normal operations such as loading. The filters can be defined to eliminate audible alarming except for the most critical proximity zones. System flexibility allows customers to tailor proximity warnings to their site needs.

Onboard, the in-cab display shows a mine map indicating the position of the operator's machine in relation to others nearby. Zones are displayed on the map and operators are notified when they enter restricted areas or exceed specified speed limits. The display shows when two or more machines' projected paths of travel intersect providing warning of a potential collision.

The office application provides system administrative functionality such as the creation and maintenance of operators, machines, avoidance zones, hazards, and speed limits. Users can create personal desktop views to see information that is important to their job. Incident Management allows the capture of proximity, speeding and zone violations which can be played back for reconstruction.

### Personnel

In underground applications, Personnel utilizes individual locator tags to identify people working at the face. This valuable information about the location and job role of tagged personnel is communicated via a high speed network so you always know where your people are working in proximity to moving equipment. It can automatically halt operations when unauthorized people enter restricted areas, while allowing service and maintenance personnel to work as required around operating equipment.

### Fatigue and Distraction Management

Fatigue, sleepiness and distraction impact each of us every day and losing focus on a mine site can have serious consequences. However, this risk can be managed and mitigated through a comprehensive Fatigue Risk Management System (FRMS) that incorporates all layers of protection against fatigue. These layers of protection include:

- Site fatigue assessments
- Training and education on managing fatigue for individuals, managers and supervisors
- Technology change management
- 24/7 monitoring
- Schedule/roster analysis and optimization

Caterpillar is the sole provider of a complete solution that brings visibility to risk factors never seen before and applies root cause data to a continuous improvement process that delivers sustainable culture change.

With specialized in-cab equipment that alerts an operator when a fatigue or distraction event is detected and data monitoring to identify risk trends, Caterpillar can help you prevent incidents in the moment and give line of sight to a host of factors that influence safety and operational performance. We also offer safety management consulting and training to help you build and sustain a culture that supports your fatigue management system.

## Health

Health delivers critical event-based machine condition and operating data for your entire fleet. It includes comprehensive, proactive health and asset monitoring capabilities, with a wide range of diagnostic, reporting tools, analytics and recommendations. The Health capability set now includes the powerful features of Cat Equipment Care Advisor providing a comprehensive suite of analytics based condition monitoring technologies for any customer type.

By identifying many types of potential equipment problems before failure, Health works to minimize unscheduled downtime and productivity loss. Plus, it helps keep your operating costs in check by streamlining service and maintenance management and scheduling. Health offers universal functionality that works with virtually any mine site asset, including off-highway trucks, wheel loaders, motor graders, wheel dozers, shovels and light-duty vehicles, as well as equipment from other manufacturers.

### Key benefits of Health include:

- Lower maintenance costs
- Improved reliability
- Saved component failures
- Extended component life
- Reduced phantom breakdowns
- Full fleet health monitoring
- Efficient data analysis
- Improved maintenance practices
- Combines equipment and application information from multiple sources, applies advanced analytics and incorporates Cat dealer expertise
- Results in early detection of issues with equipment
- Allows dealers and customers to be proactive in maintenance repair and component replacement decisions
- Automates and tracks recommendations through the repair workflow process
- Promotes knowledge sharing (across dealers and Caterpillar factory experts)

## Command

Combining the Fleet, Terrain, Detect and Health capabilities of Cat MineStar, Command enables you to implement remote control, semi-autonomous or fully autonomous mining equipment systems for dozing and underground operations.

Taking advantage of proven technologies, as well as significant advances in remote sensing and guidance, Command helps you work more safely and productively in a wide range of harsh or challenging environments. And Command systems are proven to work safely and seamlessly with other mine site activities, equipment and personnel.

## Command for Dozing

Command for dozing enables machine operation from a safe location with the operator removed from the cab. This system enhances operator safety by limiting exposure to full body vibration, dust and sound, and slips, trips and falls from machine ingress/egress. The machine can be operated by either an over the shoulder operator console or a seated operator station for longer term operations. Either system utilizes line of sight communications for near machine operation. This system is integrated with engine, implement, and power train controls. Safety controls are built in which stop the machine in case of the loss of radio, transceiver, or ECM communications. The machine will also stop in the event the operator console is tipped. Additional protection features include the use of auto-brakes when in neutral and engine over-speed protection. Perhaps the most unique feature is the integration with the Terrain avoidance zone functionality, which prevents the machine from entering predefined avoidance zones.

## Benefits of Command for dozing include:

- Enables control of machine from safe location when operating in hazardous conditions.
- Operator exposure to dust, noise and vibration can be minimized when operating remotely.
- Numerous emergency stop functions available in the following scenarios:
  - Operator Console is tipped.
  - Off-board transceiver loses power.
  - Radio communications are lost.
  - Communication to on-board transceiver or any electronic control module is lost.
- AutoBrake feature prevents machine from coasting while not being controlled.
- Avoidance Zone (optional) prevents a remotely controlled machine from entering predefined avoidance zones or 3-dimensional surfaces.
- AutoRetarder enables engine over-speed protection.
- Multiple emergency shutdown switches engaged in the cab, on the Operator Console, in the ground-level service center
- Meets ISO 15817 standards
- Meets AS/NZS 4240

## Applications

- Machine recovery
- Unstable footings
- Aggressive ripping
- Misfires
- Stockpiles
- Bench slides
- Steep slopes

### Command for Underground

Developed out of the need to reduce human exposure to injury, the system removes the operator from dangerous situations and allows them to work in a more comfortable, ergonomic environment. The system uses technology to automate and enhance operations, by enabling semi-autonomous control of Cat LHD's. Command for underground will increase productivity and make a measurable impact on your mine's bottom line.

Command for underground consists of four major sub-systems that support the functionality of the system.

#### Operator Station

The Operator Station allows machines to be operated from an ergonomically designed seat in a variety of locations. The operator can safely operate the machine from a mine control room or mobile office, either above or underground. This removes the operator from potentially dangerous environments in the mine drives underground. The Operator Station consists of a computer, three monitors, a seat and two joysticks; one controlling the movement of the machine, the other controlling the bucket.

#### Machine Automation System

The Machine Automation System consists of the on-board hardware components that make the Command for underground system function. LADAR, cameras, lights, sensors, antennas, and control modules combine to create a system that provides safety and productivity for your underground mining operation.

#### Area Isolation System

Ensures that personnel cannot enter or equipment cannot leave the operations area while the machine is in autonomous mode. The operator has the ability to arm and disarm the system to compensate for changing business needs. A barrier control panel is located at each entry to the operations area. These are connected to barriers to ensure the area is secure. The status of each barrier control panel is reported to the programmable logic controller via the Local Area Radio Network (LARN). The programmable logic controller then determines whether the Operations Area should be armed.

### Local Area Radio Network (LARN)

The LARN is a wireless Ethernet data network that enables communication between the machine and the Operator Station. The network uses the 802.11 b/g protocols and requires exclusive use of the 2.4 GHz RF spectrum. Signals from the Machine Automation System roam between LARN antennas as the machine moves within the operations area. The signals work primarily over line-of-sight, but can reach a short distance around corners. Video images and data are sent via the LARN.

### Command for Longwall

Command for longwall automates Cat plows for enhanced safety. No operator is required at the longwall face itself. Operation can be controlled from a central control station either underground — for example, at the head gate entry — or on the surface, so operators can work remotely in a dirt- and dust-free area. The outrigger steering system provides vertical horizon control. Steering is normally controlled manually, but can be automated. Shields are positioned to suit the longwall's geology and normally advance automatically with the cutting action of the plow.

- **Advanced Low Seam Longwall System:** Combines high installed power with unique features like overload protection, horizon control and incremental plowing.
- **Lowest Total Cost of Ownership:** Setting the standard for mining coal seams below 1.8 meters (90 in).
- **Industry's Most Advanced Remote Control System:** No operator required in the face during operation.
- **No Out-of-Seam Dilution:** Positive environmental impact by minimizing refuse requiring disposal.
- **Technology that Delivers Sustainability:** Opens new coal reserves that were previously classified as uneconomical to mine.





## CONTENTS

Selection, Application, Maintenance . . . . .	32-1
Tire Construction . . . . .	32-2
Bias Ply . . . . .	32-2
Radial Ply . . . . .	32-3
Tire Types . . . . .	32-3
Tire Size Nomenclature . . . . .	32-3
Code Identification for	
Off-Highway Tires . . . . .	32-4
Manufacturers' Designations:	
Firestone, Goodyear/Dunlop,	
Bridgestone, Michelin . . . . .	32-5
Titan, Triangle, Eurotire, Yokohama . . . . .	32-10
Radial Tire Identification:	
Michelin . . . . .	32-13
Goodyear . . . . .	32-14
Bridgestone . . . . .	32-15
Ton-Kilometer Per Hour Rating System . . . . .	32-16
Tire Drive-Away Recommendations . . . . .	32-17
TKPH Ratings:	
Goodyear Tires . . . . .	32-18
Bridgestone Tires . . . . .	32-29
Michelin Tires . . . . .	32-37
Triangle Tires . . . . .	32-48
Eurotire Tires . . . . .	32-50
ISO Load Index Speed Symbol:	
Michelin Tires . . . . .	32-45
Tire and Rim Association Ratings . . . . .	32-51
Tire Selection . . . . .	32-51
Guide . . . . .	32-53
Standard Cold Inflation Pressures . . . . .	32-54
Liquid Ballasting Table . . . . .	32-77

## SELECTION, APPLICATION, MAINTENANCE

Proper tire selection, application and maintenance continue to be the most important factors in earthmoving economics. Wheel tractors, loaders, scrapers, trucks, motor graders, etc. are earthmoving equipment whose productivity and payload unit cost may depend more on tire performance than any other factor.

Off-the-road tires must operate under a wide variety of conditions ranging from dry "potato dirt" through wet severe shot rock. Speed conditions vary from less than 1 mph average to 72 km/h (45 mph). Gradients may vary from 75% favorable to 30% adverse. Climatic conditions, operator skills, maintenance practices, etc. all may have a profound effect on tire life and unit costs.

Although one specific tire construction may be acceptable in a variety of applications, no one tire can meet all requirements on any one machine and perhaps not even one job. The many differences in tire requirements on earthmoving machines have resulted in a wide variety of tread and casing designs being made available. The optimum tire selection for a specific machine on a given job should be a joint decision between the user and tire supplier. Several tire manufacturers have technical and application representatives in the field for proper guidance in tire selection.

When job conditions change, it may be desirable to select a different tire configuration to meet the new requirements.

## TIRE CONSTRUCTION

The pneumatic tire is essentially a flexible pressure vessel utilizing structural members (nylon, steel cable, etc.) to contain the hoop tension resulting from the inflation pressure. Rubber is utilized as a protective coating and sealant over the structural members and makes up the tread pattern which provides the wearing medium at the ground interface. The following brief explanation of the various tire constructions will assist you in selecting tires for your specific application.

Two distinct tire constructions approved on all Cat<sup>®</sup> machines are the BIAS PLY and RADIAL PLY tires. Radial tires are designated by an “R” while a “-” represents a Bias constructed tire. For example, a 45/65-45 tire would be of Bias construction and a 45/65R45 would be of Radial construction. The following is a brief explanation of the principal features of these two constructions.

### Bias Ply

1. *Beads* — The tire beads consist of steel wire bundles (3 or 4 in larger tires) which are forced laterally by tire inflation pressure to wedge the tire firmly on the rim’s tapered bead seat. The nylon plies tie into the bead bundles. The forces inherent in the tire are transmitted from the rim through the bead bundles into the nylon.
2. *Body plies* — Layers of rubber-cushioned nylon cord comprise the tire casing. Alternating plies of cord cross the tread centerline at an angle (bias). The term “ply rating” is an index of tire strength and not the actual number of tire plies.

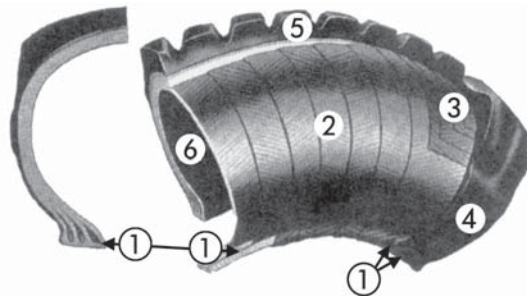

**Bias Ply Construction**

3. *Breakers or tread plies* — These, if used, are confined to the tire’s tread area and are intended to improve casing strength and provide additional protection to the body plies. Some “work” tires employ steel breakers or belts to further protect the casing.
4. *Sidewalls* — These are the protective rubber layers covering the body plies in the sidewall.
5. *Tread* — The wearing part of the tire that contacts the ground. It transmits the machine weight to the ground and provides traction and flotation.
6. *Inner liner* — This is the sealing medium that retains the air and, combined with the “O” ring seal and rim base, eliminates the need for inner tubes and flaps.
7. *Tubes and flaps (not shown)* — Required if the tire is not of tubeless construction with an inner liner.
8. *Undertread* — Protective rubber cushion lying between tread and body ply.

**Radial Ply**

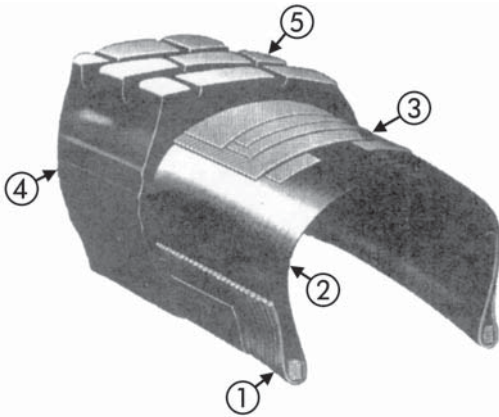

**Radial Ply Construction**

1. *Beads* — A single bead bundle of steel cables or steel strip (spiraled like a clock spring) comprise the bead at each rim interface.
2. *Radial casing* — This consists of a single layer or ply of steel cables laid archwise (on the radian) bead to bead.
3. *Belts* — Several layers or plies of steel cable form the belts which underlie the tread area around the tire circumference. The cable in each belt crosses the tread centerline at an angle with the angle being reversed from the preceding belt.
4. *Sidewalls*.
5. *Tread*.
6. *Undertread* — Protective rubber cushion lying between tread and steel belts.

**Bias and Radial Tire Advantages**

	Bias	Radial
Tread Life		X
Heat Resistance		X
Cut Resistance — Tread		X
Cut Resistance — Side Wall	X	X
Traction		X
Flotation		X
Stability	X	
Fuel Economy		X
Repairability		X

**TIRE TYPES**

Off-the-road tires are classified by application in one of the following three categories:

1. *Transport tire* — For earthmoving machines that transport material such as trucks and wheel tractors.
2. *Work tire* — Normally applied to slow moving earthmoving machines such as graders and loaders.
3. *Load and carry* — Wheel loaders engaged in transporting as well as digging.

**TIRE SIZE NOMENCLATURE**

Tire size nomenclature is derived from the approximate cross section width and rim diameter typically in the format of Tire Width, Aspect Ratio, and Rim Diameter (example: 45/65-45). Available tire types include:

1. A wide base tire has a section height to section width ratio in the range of 0.83. As an example, a 29.5-25 tire has an approximate cross section width of 749 mm (29.5") (first number) and a rim diameter of 635 mm (25") (second number).
2. A conventional tire has a section height to section width ratio in the range of 0.96. As an example, a 24.00R35 tire has an approximate cross section width of 610 mm (24") (first number) and a rim diameter of 889 mm (35") (second number).
3. A low profile tire has a section height to section width ratio in the range of 0.65. As an example, a 45/65-45 tire has an approximate cross section width of 1143 mm (45") (first number), a 65% aspect ratio designated as 65 (second number), and a rim diameter of 1143 mm (45") (third number).

If designated 45/65 R39, then the R denotes radial construction.

When comparing a wide base tire to a standard base tire, a larger first number on a wide base tire with the same rim diameter does not mean the wide base is larger in overall diameter. For example, the 18.00-25 conventional tire is larger in diameter than the 20.5-25 wide base tire. The 18.00-25 is comparable in overall diameter to the 23.5-25 wide base tire.

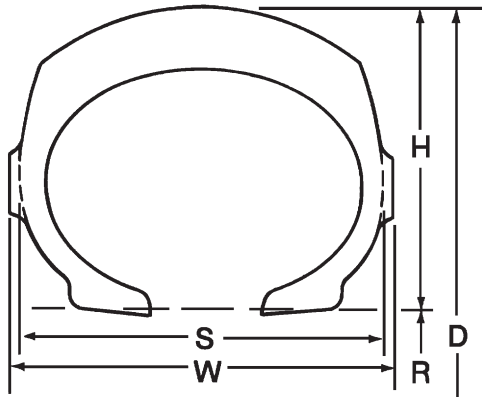

Tire cross-section

- D = Tire Overall Diameter
- R = Nominal Rim Diameter
- H = Tire Section Height
- S = Tire Section Width
- W = Tire Width (includes ornamental ribs)
- $\frac{H}{S}$  = Aspect Ratio

**CODE IDENTIFICATION FOR OFF-HIGHWAY TIRES**

The tire industry has adopted a code identification system to be used for off-the-road tires. This identification system will reduce the confusion caused by the trade names for each type of tire offered by each tire manufacturer. The industry code identification is divided into six main categories by types of service as follows:

- C — Compactor Service
- E — Earthmover Service
- G — Grader Service
- L — Loader and Dozer Service
- LS — Log-Skidder Service
- F — Industrial
- R — Agricultural Tractor
- I — Agricultural Implement

The sub-categories are designated by numerals, as follows:

Code Identification		% Tread Depth
<b>Compactor</b>		
C-1	Smooth	100
C-2	Grooved	100
<b>Earthmover</b>		
E-1	Rib	100
E-2	Traction	100
E-3	Rock	100
E-4	Rock Deep Tread	150
E-7	Flotation	80
<b>Grader</b>		
G-1	Rib	100
G-2	Traction	100
G-3	Rock	100
G-4	Rock Deep Tread	150
<b>Loader and Dozer</b>		
L-2	Traction	100
L-3	Rock	100
L-4	Rock Deep Tread	150
L-5	Rock Extra Deep Tread	250
L-3S	Smooth	100
L-4S	Smooth Deep Tread	150
L-5S	Smooth Extra Deep Tread	250
L-5/L-5S	Half Tread Extra Deep	250
<b>Log-Skidders</b>		
LS-1	Regular Tread	100
LS-2	Intermediate Tread	125
LS-3	Deep Tread	150
HF-4	Extra Deep Tread	250
<b>Industrial</b>		
F-3	Traction Tread	
<b>Agricultural Tractor</b>		
R-1	Regular Tread	
R-3	Shallow Tread	
R-4	Industrial Tractor	
<b>Agricultural Implement</b>		
I-3	Tractor Tread	

Tire and Rim Assoc. Code	Tread Type	FIRESTONE	GOODYEAR/ DUNLOP*	BRIDGESTONE	MICHELIN
<b>Compactor</b>					
C-1	Ribbed (Smooth Surfaces)		SMC-1A	RR	X LISSE COMPACTEUR
C-2	Traction (Regular)			AL2	
<b>Earthmover</b>					
E-1	Ribbed (Smooth Surfaces)				
E-2	Traction (Regular)	SGG LD (E2/L2) SGG	Custom HI-MILLER (CHM) MC-1A RL-2F (E2/G2) SG Lug SGL-2A SGL E/L-2A (E2/G2/L2)	VFT VGT VHB VHS VKT (E2/G2/L2) VSB	X-CRANE AT X CRANE+ XGC XMH S XSNOPPLUS 170E XTLA (E2/G2/L2) XVC
E-3	Rock (Regular)	SRG LD SRG	AT-2A (E3/L3) GP-2B (E3/G3/L3) GP-3D (E3/L3) HRL-3A (E3/L3) HRL-3B HRL-3C HRL-3F HRL D/L-3A (E3/G3/L3) HRL E/L-3A (E3/G3/L3) RL-2+ (E3/G3/L3) RL-3+ RL-3J (E3/L3) RT-3A+ RT-3B (E3/L3) TL-3A+ (E3/L3) UMS D/L-3A (E3/L3) UMS-3A (E3/L3) WRL-3A (E3/L3)	RL (E3/G3/L3) VEL VL2 (E3/L3) VLT VMT VRD VRF VRL WL	XAD 65-1 XADN+ XDR S XK A (L3 for 25" Rim) XMS X-STRADDLE X-TRACTION S XTS XDRA S XDL

\*Dunlop brand indicator.

# Tires | Manufacturer's Designation

Tire and Rim Assoc. Code	Tread Type	FIRESTONE	GOODYEAR/ DUNLOP*	BRIDGESTONE	MICHELIN
<b>Earthmover</b>					
<b>E-4</b>	Rock (Deep Tread)	SRG DT	GP-4B GP-4C (E4/L4) GP-4D (E4/L4) HRL-4A HRL-4B MRL-4B MRL-4D MRL-4F NRL D/L-4A (E4/L4) RL-4 RL-4A RL-4B RL-4H RL-4H II RL-4J RL-4J II RL-4L RL-4M+ RT-4A RT-4A+ RM-4A+ RM-4B+	ELS2 L317 RLS (E4/L4) VELS VLTS (E4/L4) VMTP VMTS (E4/G4) VRDP VREP VRLS VRPS VRQP VSNT (E4/L4) VZTP VZTS	X SUPERTERRAIN+ XDR™ XDR™ 2 XDT™ X-HAUL® XKD1™ X-Quarry®/X-Quarry® S XRS™ X-TRACTION™ XDR250
<b>E-5</b>	Rock (Extra-Deep Tread)				
<b>E-7</b>	Flotation	DF AP SAND&HWY E7 SAND CHAMP E7	SRB-7A	SCP2 VSJ	
<b>Grader</b>					
<b>G-1</b>	Ribbed (Smooth Surfaces)	FLOT 23 RANCHER			
<b>G-2</b>	Traction (Regular)	SGG RB (G2/L2) SGG RBTG TURF&FIELD TURF&FIELD SS	AS-3A (G2/L3) RL-2F (E2/G2) SG-2B SGG-2A SGG-2A SG SGL D/L-2A (G2/L2) SGL E/L-2A (E2/G2/L2) SP-T9* (G2/L2)	FG (G2/L2) VKT (E2/G2/L2) VSW (G2/L2) VUT (G2/L2)	XGLA2™ (G2/L2) XSNPLUS® M&S (G2/L2) XTLA™ (E2/G2/L2)
<b>G-3</b>	Rock (Regular)		GP-2B (E3/G3/L3) HRL E/L-3A (E3/G3/L3) RKG-3B RL-2+ (E3/G3/L3)	RL (E3/G3/L3)	
<b>G-4</b>	Rock (Deep Tread)	SRG DT G4	SGG-4B		
<b>G-5</b>	Rock (Extra-Deep Tread)		HRL D/L-5A		
<b>G-5S</b>	Smooth (Extra-Deep Tread)		SMO D/L-5A (G5S/L5S) SMO D/L-5B (G5S/L5S)		

\*Dunlop brand indicator.

Tire and Rim Assoc. Code	Tread Type	FIRESTONE	GOODYEAR/ DUNLOP*	BRIDGESTONE	MICHELIN
<b>Loader and Dozer</b>					
L-2	Traction (Regular)	SGG LD (E2/L2) SGG RB (G2/L2)	E91-2* SGL D/L-2A (G2/L2) SGL E/L-2A (E2/G2/L2) SP-T9* (G2/L2)	FG (G2/L2) VKT (E2/G2/L2) VSW (G2/L2) VUT (G2/L2)	XGLA2™ (G2/L2) XSNOPUS® M&S (G2/L2) XTLA™ (E2/G2/L2)
L-3	Rock (Regular)	SRG LD DURAFORCE MH SRG IDU	AS-3A (G2/L3) AT-2A (E3/L3) ELV-3A (I3/L3) GP-2B (E3/G3 /L3) GP-3D (E3/L3) HRL D/L-3A (G3/L3) HRL D/L-3B HRL D/L-3C HRL E/L-3A (E3/G3/L3) HRL-3A (E3/L3) RL-2+ (E3/G3/L3) RL-3J (E3/L3) RT-3B (E3/L3) TL-3A+ (E3/L3) UMS D/L-3A (E3/L3) UMS-3A (E3/L3) WRL-3A (E3/L3)	RL (E3/G3/L3) VCH VJT VL2 (E3/L3) VTS	STABIL'X® X STACKER™ STABIL'X® XZM™ 2 STABIL'X® XZM™ STABIL'X® XZSL® XHA™ XHA™ 2 XK® A (E3 for 24" Rim) XLD® L3 XRDN™ A
L-4	Rock (Deep Tread)	DLDT SRG DT LD PTLD IDU	DRL-4/15C GP-4C (E4/L4) GP-4D (E4/L4) HRL D/L-4/15C HRL D/L-4A HRL D/L-4B HRL D/L-4G NDL D/L-4/15C NRL D/L-4/15C NRL D/L-4A (E4/L4) NRL D/L-4D RL-4D RL-4K RT-4D SHRL XT™ D/L	NL RLS (E4/L4) VCHD VCHS VLTS (E4/L4) VSNL VSNT (E4/L4)	XLD® D1 XTXL

\*Dunlop brand indicator.



# Tires | Manufacturer's Designation

Tire and Rim Assoc. Code	Tread Type	FIRESTONE	GOODYEAR/ DUNLOP*	BRIDGESTONE	MICHELIN
<b>Loader and Dozer</b>					
<b>L-5</b>	Rock (Extra-Deep Tread)	DLSDT SDT LD DL PT	DRL D/L-5A HRL D/L-5A (G5/L5) HRL D/L-5B HRL D/L-5C NDL D/L-5/15C NRL D/L-5/15C NRL D/L-5A RL-5K RT-5D SXT D/L SXT LDR	DL VSDL VSDT	X MINE® D2 XLD® D2
<b>L-3S</b>	Smooth (Regular)	PLTD IDU	RL-3S (Smooth) SMO D/L-3A (Smooth)		
<b>L-4S</b>	Smooth (Deep Tread)		SMO D/L-4A SMO D/L-4B SMO-4B		
<b>L-5S</b>	Smooth (Extra-Deep Tread)	DLPT	RL-5S SM-5A SMO D/L-5A (G5S/L5S) SMO D/L-5B (G5S/L5S) SMO D/L-5C SMO D/L-5D SMO-5A SMO-5B SMO-5C SMO-5D	STMS VSMS VSMS2	XSM® D2+
<b>L-6S</b>	Smooth (Extra-Deep Tread)				
<b>L-5/L-5S</b>	Rock/Smooth (Extra-Deep Tread)	HTLD			

\*Dunlop brand indicator.

Tire and Rim Assoc. Code	Tread Type	FIRESTONE	GOODYEAR/ DUNLOP*	BRIDGESTONE	MICHELIN
<b>Soil Compactor</b>					
R-1	Ribbed (Smooth Surfaces)	Field and Road Performer 85 Radial 23 Radial 9100 Radial All Traction Super All Traction Super All Traction II Traction Field and Road			
R-3	Rock (Regular)	All Non-Skid Tractor Farm Service DIA Turf and Field	SFT105		
<b>Log Skidder</b>					
LS-1	Intermediate	Forestry Special CRC Forestry Special Severe Service			
LS-2					
LS-3	Deep				
HF-4	Extra Deep				
<b>Backhoe Loader</b>					
F-3	Industrial Multiple-Rib Traction	Industrial Special All Traction Utility Power Implement Super Traction Loader	Laborer	YS2	
I-3					
I-4	Industrial	All Traction Utility Duraforce RT	Industrial Sure Grip IT510 IT525 SG Lug		XMCL™ Power CL Bibload
R-4	Drive Wheel, Industrial Tractor				
<b>Skid Steer</b>					
SS	Regular		IT323 LS SGL SGL SS		
<b>High Speed Crane</b>					
MCS	Regular				

\*Dunlop brand indicator.

# Tires | Manufacturer's Designation

Tire and Rim Assoc. Code	Tread Type	TITAN	TRIANGLE	EUROTIRE	YOKOHAMA
<b>Compactor</b>					
<b>C-1</b>	Ribbed (Smooth Surfaces)				Y69 (C1/I4/L4S/L5S)
<b>C-2</b>	Traction (Regular)	Goodyear Compactor Road Roller Road Roller II			
<b>Earthmover</b>					
<b>E-1</b>	Ribbed (Smooth Surfaces)				Y103 (E2/G2/L2)
<b>E-2</b>	Traction (Regular)	TGD2 (E2/L2)	TB515 (E2/G2/L2) TB536 (E2/G2/L2) TB586 TM518 (E2/L2) TL508 (E2/L2)		
<b>E-3</b>	Rock (Regular)	007 MFT (E3/E4) CM100 LCM MXL (E3/L3) ND LCM MCS SL 100 STL2+ STL3 Super Rigger Super Rigger LSW	TB516 (E3/L3) TB526 TB598 (E3/L3) TL528 (E3/L3) TL559 TL568+	U-11 U-12	RB31 (E3/L3) RL31 (E3/L3) RT31 (E3/L3) Y565 Y67 (E3/G3/I3/L3)
<b>E-4</b>	Rock (Deep Tread)	007 MFT (E3/E4) CH 150 (E4/L4) CM 150 DTE4 DTH4 ND Super LCM Quarry Special CM 150 Super LCM	TB516S TB526S TB598S TL558S	DR004 LR004 (E4/L4) ETRAC ETRAC ADT EROCK U-11 U-12 U-14	RB41 RB42 RL42 RL45 (E4/L4) RT41 (E4/L4) Y523 (E4/I4) Y523R/U Y567
<b>E-5</b>	Rock (Extra-Deep Tread)				
<b>E-7</b>	Flotation	Super Sand Flotation			Y65
<b>Grader</b>					
<b>G-1</b>	Ribbed (Smooth Surfaces)				RT21 Y103 (E2/G2/L2)
<b>G-2</b>	Traction (Regular)	Grader HD (G2/L2) HD 2000 II Loader Grader III (G2/L2) Super Grader (G2/L2) TG2 TGL2 (G2/L2) TGS2	TB515 (E2/G2/L2) TB536 (E2/G2/L2)		
<b>G-3</b>	Rock (Regular)				Y67 (E3/G3/I3/L3)
<b>G-4</b>	Rock (Deep Tread)				
<b>G-5</b>	Rock (Extra-Deep Tread)				
<b>G-5S</b>	Smooth (Extra-Deep Tread)				

Tire and Rim Assoc. Code	Tread Type	TITAN	TRIANGLE	EUROTIRE	YOKOHAMA
<b>Loader and Dozer</b>					
L-2	Traction (Regular)	Grader HD (G2/L2) Lift Rigger II Loader Dozer II Loader Grader III (G2/L2) Super Grader (G2/L2) TGD2 (E2/L2) TGL2 (G2/L2)	TB515 (E2/G2/L2) TB536 (E2/G2/L2) TM518 (E2/L2) TL508 (E2/L2)		Y103 (E2/G2/L3) Y548
L-3	Rock (Regular)	LCM LD 100 MXL (E3/L3) ND LCM STL2+ (E3/L3) STL3 (E3/L3) Super Rigger (E3/L3)	TB516 (E3/L3) TB598 (E3/L3) TL528 (E3/L3)	F220	RB31 (E3/L3) RL31 (E3/L3) RT31 (E3/L3) Y526K Y575 Y67 (E3/G3/I3/L3)
L-4	Rock (Deep Tread)	CH 150 (E4/L4) CM 150 LD 150 LS 150 Super LCM		LR004 (E4/L4)	RL45 (E4/L4) RT41 (E4/L4) Y545 Y67E
L-5	Rock (Extra-Deep Tread)	LD 250 LD 250 Belted	TL535S+ TL538S+ TL559S+	ETRAC WL U-54	Y524 Y525 RL51 RL52
L-3S	Smooth (Regular)				
L-4S	Smooth (Deep Tread)	Super Smooth	TSMS		Y69 (C1/I4/L4S/L5S) Y69K (L4S/L5S) Y69U (L4S/L5S)
L-5S	Smooth (Extra-Deep Tread)	LD 250 Super Smooth LD 250 Super Smooth Belted LD 250 Super Smooth UGM Super Smooth	TSMS+		Y69 (C1/I4/L4S/L5S) Y69K (L4S/L5S) Y69U (L4S/L5S) R69
L-6S	Smooth (Extra-Deep Tread)				Y524Z
L-5/L-5S	Rock/Smooth (Extra-Deep Tread)	LD 250 Half-Trac LD250 Half-Trac Belted			
<b>Soil Compactor</b>					
R-1	Ribbed (Smooth Surfaces)				
R-3	Rock (Regular)	Goodyear SFT105 Goodyear Smooth			
<b>Log Skidder</b>					
LS-1					
LS-2	Intermediate	Goodyear Logger Lug III Goodyear Logger Lug III HD			
LS-3	Deep				
HF-4	Extra Deep	Goodyear Logger Lug III Flotation			

# Tires | Manufacturer's Designation

Tire and Rim Assoc. Code	Tread Type	TITAN	TRIANGLE	EUROTIRE	YOKOHAMA
<b>Backhoe Loader</b>					
F-3	Industrial Multiple-Rib	Contractor Goodyear Laborer Goodyear Multi Rib Industrial Front Tractor			
I-3	Traction	Contractor Contractor II Goodyear Sure Grip Implement Goodyear Sure Grip Lug Grizz LSW G2E TI422			
I-4 R-4	Industrial Drive Wheel, Industrial Tractor	Goodyear IT510 Goodyear IT515 HS Goodyear IT520 Goodyear IT525 Goodyear IT530 Goodyear IT610 Grizz LSWG99F Goodyear Industrial Contractor Industrial Sure Grip Goodyear Industrial Tractor Industrial Tractor Lug			Y548
<b>Skid Steer</b>					
SS	Regular				
<b>High Speed Crane</b>					
MCS	Regular				RB01 RB03 RS01

## RADIAL TIRE IDENTIFICATION

### Code Identification for Michelin Tires

All Michelin earthmover tires are radial construction, designated by the “X” marking. They contain a single steel radial ply with a series of steel belts placed around the tire’s circumference which reinforce and stabilize the tread.

Following are the tread designs currently available from Michelin with the different internal constructions depending on the application.

- Type A4** Particularly resistant to cuts, tread tearing and abrasion on very rough surfaces.
- Type A** Particularly resistant to cuts, tread tearing and abrasion at average speeds which are higher than those for A4 (above).
- Type MB4** Compromise solution between abrasion resistance and average speed on rough surfaces (from 49 inches) with a higher wear resistance than the Type B4.
- Type B4** Compromise solution between abrasion resistance and average speed on rough surfaces.
- Type B** Higher resistance to internal heat generation on surfaces which are not particularly rough.
- Type MC4** Adapted to running on long cycles at high speeds on well-maintained roads with a higher wear resistance than the Type C4.
- Type C4** Adapted to running on long cycles at high speeds on well-maintained roads.
- Type C** Very high resistance to high/average speeds on long cycles running on well-maintained roads.

Since Michelin radial tires contain a single steel casing ply, they utilize the industry method of designating radial tire strength in terms of “stars.” Their system consists of a one star, two star, and three star rating as an indication of the tire’s carrying capacity. The one star is the lightest construction, generally used on work and slow moving transport machines. Two star tires are used on most medium and high speed transport machines. Three star construction provides the greatest carrying capacity for a given size and is only available in small standard base tires.

This combination of tread designs and types of construction provides a range of radial tires which cover most earthmoving applications. We recommend that in applying steel radial tires to your machines you provide all site condition data to the tire manufacturer. Obtain their recommendations as to which tire will provide the most economical operation.

### Code Identification for Goodyear Radial Tires

All Goodyear steel radial earthmover tires have been designated *Unisteel* followed by a three or four digit alpha-numeric code that identifies the particular tread. For example, for a RL-2+, RL stands for Rock Lug and indicates that the upper sidewall has rock protection. The number in the code corresponds to the tire industry identification system (2-traction, 3-rock, etc). The fourth digit, if any, is used to designate tread design differences for the same basic tread type.

Following are the radial tread designs currently available from Goodyear with the compound and construction types depending on the application.

<b>Compound Description</b>	<b>Compound Code</b>
High Heat Resistant	2
Heat Resistant	3
Standard Abrasion Resistant	4
Ultra Abrasion Resistant	6
<b>Construction Description</b>	<b>Construction Code</b>
Standard	S
Heavy Duty	H
Extra Heavy Duty	HW
Steel Breakers	J
Heavy Undertread	U
Low Angle Belts	SL

<b>Tread Design</b>	<b>Tread Compounds</b>			<b>Primary TRA Code(s)</b>
	<b>2S</b>	<b>4S</b>	<b>6S</b>	
AT-2A	X	X	X	E-3/L-3
GP-2B	X	X	X	E-3/G-3/L-3
GP-3D	X	X	X	E-3/L-3
GP-4B	X	X	X	E-4
GP-4B AT	X	X	X	E-4/G-4
GP-4C	X	X	X	E-4/G-4/L-4
GP-4D	X	X	X	E-4/L-4
RL-2+	X	X	X	E-3/G-3/L-3
RL-2F	X	X	X	E-2/G-2/L-2
RL-3+	X	X	X	E-3
RL-3A	X	X	X	E-3
RL-3J	X	X	X	E-3
RL-4	X	X	X	E-4
RL-4A	X	X	X	E-4
RL-4B	X	X	X	E-4
RL-4H	X	X	X	E-4
RL-4H II	X	X	X	E-4
RL-4J	X	X	X	E-4
RL-4J II	X	X	X	E-4
RL-4K		X	X	L-4
RL-4M+	X	X	X	E-4
RL-5K		X	X	L-5
RM-4A+	X	X	X	E-4
RM-4B+				
RT-3A+	X	X	X	E-3
RT-3B			X	L-3
RT-4A	X	X	X	E-4
RT-4A+	X	X	X	E-4
TL-3A+	X	X	X	E-3/L-3

A star rating system instead of the ply rating system indicates the casing strength of radial tires. These symbols indicate the recommended inflation for a particular tire load. Following the star rating code is Goodyear's Custom Compound and Construction code. For a tire designated "2S" the 2 indicates a heat resistant compound and the S indicates standard construction. The higher the number the greater the abrasion and cut resistance with a corresponding lower TKPH/TMPH rating.

### Code Identification for Bridgestone Radial Tires

The Bridgestone steel radial earthmover has been designated as V-Steel. Following are the radial tread designs currently available from Bridgestone with the compound and construction types depending on the application.

#### Bridgestone Compound and Structure Codes

1A	Standard
2A	Cut-Resistant
2V	Special Cut Resistant (Steel Breaker)
2Z	Special Cut Resistant (Side Steel Breaker)
3A	Heat-Resistant
E	Earthmover
G	Grader
D	Loader and Dozer
S	Logging

Tread Design	Tread Name	Tread Compounds				Primary TRA Code(s)
		1A	2A	2V	3A	
VELS	V-Steel E-Lug S	X	X		X	E-4
VELSL	V-Steel E-Lug S				X	E-4
VFT	V-Steel F-Traction	X	X		X	E-2
VHS	V-Steel H-Service				X	E-2
VJT	V-Steel J-Traction		X			E-3/L-3
VKT	V-Steel K-Traction	X	X			E-2/G-2/L-2
VLТ	V-Steel L-Traction	X	X		X	E-3/L-3
VLTS	V-Steel L-Traction S		X			E-4/L-4
VMT	V-Steel M-Traction	X	X		X	E-3/L-3
VMTP	V-Steel M-Traction Premium	X	X		X	E-4
VMTS	V-Steel M-Traction S	X	X		X	E-4/G-4
VRDP	V-Steel Rock Deep Premium	X	X		X	E-4
VREP	V-Steel Rock E-Premium	X	X		X	E-4
VRF	V-Steel Rock Fast	X			X	E-3
VRL	V-Steel R-Lug	X				E-3
VRLS	V-Steel R-Lug S	X	X		X	E-4
VRPS	V-Steel Rock Premium Service	X	X		X	E-4
VRQP	V-Steel Rock Quarry Premium		X			E-4
VSБ	V-Steel S-Block		X			E-2
VSDL	V-Steel D-Lug		X			L-5
VSDT	V-Steel Super Deep Traction		X			L-5
VSMS	V-Steel Smooth Tread-MS		X	X		L-5S
VSNL	V-Steel N-Lug		X			L-4
VSNT	V-Steel N-Traction		X			E-4/L-4
VSW	V-Steel Snow Wedge		X			G-2/L-2
VTS	V-Steel Traction-Stability		X			L-3
VUT	V-Steel Ultra Traction		X			G-2/L-2
VZTP	V-Steel Z-Traction Premium	X	X		X	E-4
VZTS	V-Steel Z-Traction S	X	X		X	E-4

The casing strength, i.e., load carrying capacity of tire is indicated by star rating system; 1-star, 2-star and 3-star. Bridgestone's Off-the-Road tires are designed and produced to meet the commonly accepted international standards, those set by the TRA (Tire and Rim Association) in the U.S.A., by the ETRTO (European Tire and Rim Technical Organization) in Europe and/or by the JATMA (Japan Automobile Tire Manufacturers' Association) in Japan. Where differences exist between the TRA, ETRTO and JATMA standards, Bridgestone selects the most appropriate.

### Code Identification for Eurotire Radial and Bias Tires

Eurotire manufactures a range of bias-ply and radial tires for use on mining equipment. Eurotire steel radial tires are designated with an "EU." The following are the radial tread designs currently available from Eurotire with the compound and construction types for a variety of applications.

Compound Description	Compound Code
Heat Resistant	H
Intermediate	S
Abrasion Resistant	A

Tread Design	Compound Code			TRA Code(s)
	H	S	A	
EUROK	X	X	X	E4
EUTRAK	—	X	X	E3, E4, L4

Eurotire radial tires are marked with a star rating system to indicate casing strength. Eurotire manufactures 2 star radial tires.

It is important to understand the specific usage and operating conditions of your job site so that the most appropriate tire choice can be determined. Eurotire representatives can help you make the most informed decision regarding tire choice, including weighing the benefits of radial vs. bias, selecting between different tread designs and compounds and providing service solutions to best suit your specific needs.



## TON-KILOMETER PER HOUR (TKPH)

Tire selection and machine operating practices have, in some cases, become the critical factors in the over-all success of earthmoving ventures. One of the most serious problems occur when tires are operated at temperatures above their capabilities. Separation and related failures occur. To help you avoid temperature related failures, Caterpillar has been instrumental in developing the *Ton-Kilometer Per Hour* (TKPH), also known as *Ton-Mile Per Hour* (TMPH), method of rating tires. The formula to convert a TKPH rating to a TMPH rating is:

$$\text{TMPH} = \text{TKPH} \times 0.685$$

### Heat and Tire Failure

Tire manufacturing requires heat in the vulcanizing process converting crude rubber and additives into a homogeneous compound. The heat required is typically above 132° C (270° F).

A tire also generates heat as it rolls and flexes. Heat generated faster than it can be radiated into the atmosphere gradually builds within the tire and reaches maximum level at the outermost ply or belt.

Over time, enough heat can develop from overflexing to actually reverse the vulcanizing process or “revert” the rubber causing ply separation and tire failure. Only a brief time at reversion temperature initiates the failure. Experience shows that few pure heat separation cases occur. Most so-called heat separations are in tires operating below the reversion level.

As a tire’s operating temperature increases the rubber and textiles within significantly lose strength. The tire becomes more susceptible to failures from cornering, braking, impact, cut through, fatigue and heat separation. If operating tires at higher temperatures is absolutely necessary, it is essential the machines be operated to reduce the probability of premature tire failure. No hard cornering without superelevation, no panic braking, etc.

The TKPH formula was developed to predict tire temperature buildup. The system is a method of rating tires in proportion to the amount of work they can do from a temperature standpoint. It utilizes the product of *load* × *speed* to derive an index of the tire temperature buildup. Even at or below a tire’s TKPH, failures may be initiated by overstressing the tires.

It is possible by using a needle type pyrometer to measure temperature at any desired point within the tire casing. However, the instrumentation and the technique does not lend itself to general field use. The greatest difficulty is locating the thickest (therefore the hottest) tread bar in any given tire using giant calipers. The tire must then be drilled along the centerline of this bar from shoulder to shoulder at 52 mm (2”) intervals. These 3.18 mm (1/8”) diameter holes extend down through the tread and undertread to the topmost reinforcement. This procedure is fully described under SAE Recommended practice J1015.

The TKPH rating system as given in this SAE specification is approved by most tire manufacturers. Michelin, in addition to providing TKPH ratings has developed their own speed/load carrying rating system and we recommend that Michelin be consulted where high tire temperatures are a concern.

Heat generation in a specific tire at recommended pressure depends on three factors:

- the weight the tire is carrying (flex per revolution),
- the speed the tire is traveling over the ground (flexures over a period of time), and
- the air temperature surrounding the tire (ambient temperature) and road surface temperature.

Once a tire manufacturer has determined a tire’s temperature characteristics and expressed them in TKPH, the above listed specific job conditions can be used to determine any tire’s maximum work capacity. These conditions provide on site ability to predict and avoid costly tire separations.

### Ton-Kilometer-Per-Hour Rating System

The tire TKPH can be matched to the site TKPH as well as compared with TKPH values of different makes and types of tires.

#### TKPH Job Rate

Average Tire Load × Average Speed for the shift

#### Average Tire Load

$$\frac{\text{“Empty” tire load} + \text{“loaded” tire load}}{2}$$

#### Average Speed

$$\frac{\text{Round trip distance in kilometers} \times \text{number of trips}}{\text{Total Hours (in the shift)}}$$

For excessive haul length (32 kilometers or more) consult your tire representative for modification to the TKPH value.

To use in the United States Customary System, change kilometers to miles and use short tons.

It should be noted that prolonged operation at high casing temperatures can fatigue the nylon at the flex points in the sidewalls.

The following are the most recent TKPH ratings as made available by Goodyear, Michelin and Bridgestone, and are subject to change on their part at any time. Other tire manufacturers' TKPH ratings will be included in future handbook editions when and if made available. For latest TKPH ratings, consult specific tire manufacturer at time of machine and/or tire purchase.

### Load-and-Carry TKPH

The wheel loader, when used in load-and-carry applications, may encounter temperature problems similar to those normally associated only with tires on scrapers, trucks and wagons. **Do not place the vehicle in load-and-carry applications without first consulting the tire manufacturer, or obtaining maximum load and speed ratings and pressure recommendations from the tire manufacturer.**

### Conventional and Radial Steel Cord Tire Options

Tire options now provide types to operate in conditions ranging from rock and abrasive materials, to jobs with high speed hauls in good materials.

The best tire type can be different for the drive tires than for other tires on the same machine. TKPH should be calculated for all tires.

## TIRE DRIVE-AWAY RECOMMENDATIONS

Heat separation can be a problem during machine delivery and moving machines from one job to another. Whenever roading earthmoving machines, *check your supplier for the tire manufacturer's recommended speed limitations on the specific tires involved.*

Some tire manufacturers also recommend that vehicles equipped with extra tread depth or special compounded tires should not be roaded without their specific approval. Our tests support this recommendation, especially for L-3, L-4, E-4 and L-5 tires.

**TKPH RATINGS**  
**AT 38° C (100° F) AMBIENT TEMPERATURE**  
**For Haul Lengths of 32 km (20 miles) or Less One Way**  
**Maximum Speed Not to Exceed 48 km (30 miles) per Hour**

*Because of the variance between specific tires it is recommended that at the time of purchase you check with your tire supplier for the manufacturer's specific TKPH ratings for the tires purchased.*

**GOODYEAR RADIAL PLY — CONVENTIONAL SIZES**

Industry Code	Tread Design	E-3																	
		AT-2A			AT-3A			GP-2B			RL-3+			RL-3A			RL-3J		
Custom Code		2S	4S	6S	2S	4S	6S	2S	4S	6S	2S	4S	6S	2S	4S	6S	2S	4S	6S
14.00R20	TKPH	—	—	—															
16.00R20	TKPH	—	—	—	—	—	—												
16.00R21	TKPH	—	—	—															
12.00R24	TKPH																		
13.00R24	TKPH																		
14.00R24	TKPH							—	—	—									
16.00R24	TKPH																		
14.00R25	TKPH							—	—	—									
16.00R25	TKPH							—	—	—	115	85	70						
18.00R25	TKPH										155	115	95						
18.00R33	TKPH										180	135	110						
21.00R33	TKPH																		
21.00R35	TKPH										245	185	145						
24.00R35	TKPH										300	230	180						
24.00R49	TKPH										375	280	—						
27.00R49	TKPH						450	375	—		375	310	185						
30.00R51	TKPH																		
33.00R51	TKPH																620	480	290
36.00R51	TKPH										525	450	270						
37.00R57	TKPH																		
40.00R57	TKPH													785	600	355			

**TKPH RATINGS**  
**AT 38° C (100° F) AMBIENT TEMPERATURE**  
**For Haul Lengths of 32 km (20 miles) or Less One Way**  
**Maximum Speed Not to Exceed 48 km (30 miles) per Hour**

*Because of the variance between specific tires it is recommended that at the time of purchase you check with your tire supplier for the manufacturer's specific TKPH ratings for the tires purchased.*

**GOODYEAR RADIAL PLY — CONVENTIONAL SIZES**

Industry Code	E-4																	
	GP-4B			GP-4C			GT-4B			RL-4			RL-4A			RL-4B		
Tread Design	2S	4S	6S	2S	4S	6S	2S	4S	6S	2S	4S	6S	2S	4S	6S	2S	4S	6S
Custom Code	2S	4S	6S	2S	4S	6S	2S	4S	6S	2S	4S	6S	2S	4S	6S	2S	4S	6S
14.00R20 TKPH																		
16.00R20 TKPH																		
16.00R21 TKPH																		
12.00R24 TKPH																		
13.00R24 TKPH																		
14.00R24 TKPH																		
16.00R24 TKPH																		
14.00R25 TKPH																		
16.00R25 TKPH																		
18.00R25 TKPH										125	95	75				130	100	80
18.00R33 TKPH				—	—	—				150	115	90				155	120	90
21.00R33 TKPH																205	160	127
21.00R35 TKPH																—	—	—
24.00R35 TKPH							260	200	155							270	205	160
24.00R49 TKPH										—	260	—				—	—	—
27.00R49 TKPH	370	285	215				360	275	210	425	335	—	350	270	210	375	290	225
30.00R51 TKPH																		
33.00R51 TKPH	490	370	260															
36.00R51 TKPH																		
37.00R57 TKPH				615	460	295												
40.00R57 TKPH													785	600	355	865	660	390

**TKPH RATINGS**  
**AT 38° C (100° F) AMBIENT TEMPERATURE**  
**For Haul Lengths of 32 km (20 miles) or Less One Way**  
**Maximum Speed Not to Exceed 48 km (30 miles) per Hour**

*Because of the variance between specific tires it is recommended that at the time of purchase you check with your tire supplier for the manufacturer's specific TKPH ratings for the tires purchased.*

**GOODYEAR RADIAL PLY — CONVENTIONAL SIZES**

Industry Code	Tread Design	RL-4H			RL-4HII			RL-4J			RL-4JII			RL-4K			RL-4L		
		2S	4S	6S	2S	4S	6S	2S	4S	6S	2S	4S	6S	2S	4S	6S	2S	4S	6S
14.00R20	TKPH																		
16.00R20	TKPH																		
16.00R21	TKPH																		
12.00R24	TKPH						75	55	—										
13.00R24	TKPH																		
14.00R24	TKPH						85	65	—				—	—	—	—	—	—	—
16.00R24	TKPH																		
14.00R25	TKPH						85	65	—								—	—	—
16.00R25	TKPH																		
18.00R25	TKPH						130	100	—										
18.00R33	TKPH	155	120	90			155	120	90										
21.00R33	TKPH	215	165	130															
21.00R35	TKPH				215	165	130	215	165	130	215	165	130						
24.00R35	TKPH				270	205	160	270	205	160	270	205	160						
24.00R49	TKPH							320	245	190									
27.00R49	TKPH	345	265	200				375	300	180	375	300	180						
30.00R51	TKPH	450	340	205							410	310	185						
33.00R51	TKPH	470	360	250	470	360	250				520	395	270						
36.00R51	TKPH	565	490	300							515	445	270						
37.00R57	TKPH	655	490	315	550	410	245				620	480	290						
40.00R57	TKPH																		

**TKPH RATINGS**  
**AT 38° C (100° F) AMBIENT TEMPERATURE**  
**For Haul Lengths of 32 km (20 miles) or Less One Way**  
**Maximum Speed Not to Exceed 48 km (30 miles) per Hour**

*Because of the variance between specific tires it is recommended that at the time of purchase you check with your tire supplier for the manufacturer's specific TKPH ratings for the tires purchased.*

**GOODYEAR RADIAL PLY – CONVENTIONAL SIZES**

Industry Code	E-4											
	RL-4M+			RM-4A+			RT-4A			RT-4A+		
Tread Design	2S	4S	6S	2S	4S	6S	2S	4S	6S	2S	4S	6S
Custom Code	2S	4S	6S	2S	4S	6S	2S	4S	6S	2S	4S	6S
14.00R20 TKPH												
16.00R20 TKPH												
16.00R21 TKPH												
12.00R24 TKPH												
13.00R24 TKPH												
14.00R24 TKPH												
16.00R24 TKPH												
14.00R25 TKPH												
16.00R25 TKPH												
18.00R25 TKPH												
18.00R33 TKPH							160	125	94			
21.00R33 TKPH												
21.00R35 TKPH												
24.00R35 TKPH										275	210	165
24.00R49 TKPH												
27.00R49 TKPH				410	320	250				410	320	250
30.00R51 TKPH												
33.00R51 TKPH	540	410	290	540	410	285						
36.00R51 TKPH												
37.00R57 TKPH	770	590	350	770	590	350						
40.00R57 TKPH												

**TKPH RATINGS**  
**AT 38° C (100° F) AMBIENT TEMPERATURE**  
**For Haul Lengths of 32 km (20 miles) or Less One Way**  
**Maximum Speed Not to Exceed 48 km (30 miles) per Hour**

*Because of the variance between specific tires it is recommended that at the time of purchase you check with your tire supplier for the manufacturer's specific TKPH ratings for the tires purchased.*

**GOODYEAR RADIAL PLY – WIDE BASE SIZES**

Industry Code	E-3																	
	AT-2A			GP-2B			GP-3D			RL-2+			RL-3J			RT-3A		
	2S	4S	6S	2S	4S	6S	2S	4S	6S	2S	4S	6S	2S	4S	6S	2S	4S	6S
15.5R25 TKPH				—	—	—												
17.5R25 TKPH	130	75	65	135	105	95				100	75	—	85	—	—			
20.5R25 TKPH				150	115	105				120	90	—						
23.5R25 TKPH				175	135	115	175	135	115	135	100	—						
26.5R25 TKPH				195	155	130				155	115	—						
29.5R25 TKPH				235	185	155				185	140	—						
29.5R29 TKPH										210	160	—						
33.25R29 TKPH																285	220	—
33.25R35 TKPH													—	230	—			
37.25R35 TKPH													—	260	—			
37.5R39 TKPH													—	295	—			

Industry Code	E-3									E-4											
	RT-3A+			TL-3A+			GP-4B			GP-4B AT			GP-4C			GP-4D			GT-4A		
	2S	4S	6S	2S	4S	6S	2S	4S	6S	2S	4S	6S	2S	4S	6S	2S	4S	6S	2S	4S	6S
15.5R25 TKPH																					
17.5R25 TKPH				100	75	—															
20.5R25 TKPH				120	90	—				—	—	—				—	—	—			
23.5R25 TKPH				135	100	—	—	—	—	135	104	90	—	—	—	—	—	—			
26.5R25 TKPH				155	115	—				147	109	91				—	—	—			
29.5R25 TKPH				185	145	125				165	130	105				170	135	115	—	—	—
29.5R29 TKPH																					
33.25R29 TKPH																					
33.25R35 TKPH																					
37.25R35 TKPH	—	—	—																		
37.5R39 TKPH																					

**TKPH RATINGS**  
**AT 38° C (100° F) AMBIENT TEMPERATURE**  
**For Haul Lengths of 32 km (20 miles) or Less One Way**  
**Maximum Speed Not to Exceed 48 km (30 miles) per Hour**

*Because of the variance between specific tires it is recommended that at the time of purchase you check with your tire supplier for the manufacturer's specific TKPH ratings for the tires purchased.*

**GOODYEAR RADIAL PLY — 95 SERIES SIZES**

Industry Code	E-3					
	AS-3A			GP-2B		
Tread Design	2S	4S	6S	2S	4S	6S
Custom Code	2S	4S	6S	2S	4S	6S
385/95R24 TKPH	—	—	—	—	—	—
385/95R25 TKPH	—	—	—	—	—	—
445/95R25 TKPH	—	—	—	—	—	—

**TKPH RATINGS**  
**AT 38° C (100° F) AMBIENT TEMPERATURE**  
**For Haul Lengths of 32 km (20 miles) or Less One Way**  
**Maximum Speed Not to Exceed 48 km (30 miles) per Hour**

*Because of the variance between specific tires it is recommended that at the time of purchase you check with your tire supplier for the manufacturer's specific TKPH ratings for the tires purchased.*

**GOODYEAR RADIAL PLY — 90 SERIES SIZES**

Industry Code	E-4					
	RL-4B			RM-4A+		
Tread Design	2S	4S	6S	2S	4S	6S
Custom Code	2S	4S	6S	2S	4S	6S
46/90R57 TKPH	910	690	410	980	750	440



**TKPH RATINGS**  
**AT 38° C (100° F) AMBIENT TEMPERATURE**  
**For Haul Lengths of 32 km (20 miles) or Less One Way**  
**Maximum Speed Not to Exceed 48 km (30 miles) per Hour**

*Because of the variance between specific tires it is recommended that at the time of purchase you check with your tire supplier for the manufacturer's specific TKPH ratings for the tires purchased.*

**GOODYEAR RADIAL PLY — 80 SERIES SIZES**

Industry Code	E-2			E-3						E-4		
	SP-T9			GP-2B			RM-3A			RM-4A+		
Tread Design	SP-T9			GP-2B			RM-3A			RM-4A+		
Custom Code	2S	4S	6S	2S	4S	6S	2S	4S	6S	2S	4S	6S
335/80R18 TKPH	—	—	—									
395/80R25 TKPH				—	—	—						
445/80R25 TKPH				—	—	—						
525/80R25 TKPH				—	—	—						
605/80R25 TKPH				—	—	—						
53/80R63 TKPH							1200	920	—	1070	820	—
59/80R63 TKPH							1500	1150	—	1300	995	—

**TKPH RATINGS**  
**AT 38° C (100° F) AMBIENT TEMPERATURE**  
**For Haul Lengths of 32 km (20 miles) or Less One Way**  
**Maximum Speed Not to Exceed 48 km (30 miles) per Hour**

*Because of the variance between specific tires it is recommended that at the time of purchase you check with your tire supplier for the manufacturer's specific TKPH ratings for the tires purchased.*

**GOODYEAR RADIAL PLY — 75 SERIES SIZES**

Industry Code	E-3					
	GP-2B			RT-3A+		
Tread Design	GP-2B			RT-3A+		
Custom Code	2S	4S	6S	2S	4S	6S
40.5/75R39 TKPH	400	305	240	375	290	220

**TKPH RATINGS**  
**AT 38° C (100° F) AMBIENT TEMPERATURE**  
**For Haul Lengths of 32 km (20 miles) or Less One Way**  
**Maximum Speed Not to Exceed 48 km (30 miles) per Hour**

*Because of the variance between specific tires it is recommended that at the time of purchase you check with your tire supplier for the manufacturer's specific TKPH ratings for the tires purchased.*

**GOODYEAR RADIAL PLY — 65 SERIES SIZES**

Industry Code	E-3												E-4		
	AT-2A			GP-3D			RL-2+			TL-3A+			GP-4D		
Tread Design	2S	4S	6S	2S	4S	6S	2S	4S	6S	2S	4S	6S	2S	4S	6S
Custom Code	2S	4S	6S	2S	4S	6S	2S	4S	6S	2S	4S	6S	2S	4S	6S
555/65R25 TKPH	195	—	—												
600/65R25 TKPH				132	99	66									
650/65R25 TKPH				144	108	73									
750/65R25 TKPH				162	120	78	155	115	75	—	—	—			
775/65R29 TKPH													169	125	105
800/65R29 TKPH													169	125	105
875/65R29 TKPH													185	150	121

**TKPH RATINGS**  
**AT 38° C (100° F) AMBIENT TEMPERATURE**  
**For Haul Lengths of 32 km (20 miles) or Less One Way**  
**Maximum Speed Not to Exceed 48 km (30 miles) per Hour**

*Because of the variance between specific tires it is recommended that at the time of purchase you check with your tire supplier for the manufacturer's specific TKPH ratings for the tires purchased.*

**GOODYEAR BIAS PLY – CONVENTIONAL SIZES**

Industry Code	Tread Design	E-3								
		GP-2B			HRL-3A			WRL-3A		
Custom Code	TKPH	2S	4S	6S	2S	4S	6S	2S	4S	6S
9.00-15	TKPH									
9.00-16	TKPH									
16.00-16	TKPH									
12.00-20	TKPH				—	—	—			
14.00-20	TKPH				—	—	—	—	—	—
16.00-20	TKPH									
12.00-24	TKPH				—	—	—			
14.00-24	TKPH				—	—	—	—	—	—
16.00-24	TKPH				—	—	—			
14.00-25	TKPH				—	50	—			
16.00-25	TKPH	—	—	—	—	70	—			
18.00-25	TKPH				125	90	—			
21.00-25	TKPH				—	—	—			
18.00-33	TKPH				150	110	—			
21.00-35	TKPH				200	145	—			
24.00-35	TKPH				—	175	—			
21.00-49	TKPH									
24.00-49	TKPH									
27.00-49	TKPH									
30.00-51	TKPH									
33.00-51	TKPH									
36.00-51	TKPH									

**TKPH RATINGS**  
**AT 38° C (100° F) AMBIENT TEMPERATURE**  
**For Haul Lengths of 32 km (20 miles) or Less One Way**  
**Maximum Speed Not to Exceed 48 km (30 miles) per Hour**

*Because of the variance between specific tires it is recommended that at the time of purchase you check with your tire supplier for the manufacturer's specific TKPH ratings for the tires purchased.*

**GOODYEAR BIAS PLY – CONVENTIONAL SIZES**

Industry Code	E-4												E-7						
	HRL-4B			HRL-4D			MRL-4B			MRL-4D			PVG-7A			SRB-7A			
	2S	4S	6S	2S	4S	6S	2S	4S	6S	2S	4S	6S	2S	4S	6S	2S	4S	6S	
9.00-15	TKPH																		
9.00-16	TKPH																		
16.00-16	TKPH																		
12.00-20	TKPH																		
14.00-20	TKPH																		
16.00-20	TKPH																		
12.00-24	TKPH																		
14.00-24	TKPH																		
16.00-24	TKPH																		
14.00-25	TKPH																		
16.00-25	TKPH	90	65	—															
18.00-25	TKPH	—	80	—				74	—	—								—	160
21.00-25	TKPH																	—	185
18.00-33	TKPH	—	100	85															
21.00-35	TKPH	180	130	110					—	115	—								
24.00-35	TKPH	—	160	—					—	140	—								
21.00-49	TKPH	—	160	—															
24.00-49	TKPH	—	190	165					—	165	—	234	175	—					
27.00-49	TKPH	310	235	175								—	190	—					
30.00-51	TKPH	—	265	—					—	245	—								
33.00-51	TKPH	395	300	—															
36.00-51	TKPH	465	335	—	450	—	—	—	325	—									

**TKPH RATINGS  
AT 38° C (100° F) AMBIENT TEMPERATURE  
For Haul Lengths of 32 km (20 miles) or Less One Way  
Maximum Speed Not to Exceed 48 km (30 miles) per Hour**

*Because of the variance between specific tires it is recommended that at the time of purchase you check with your tire supplier for the manufacturer's specific TKPH ratings for the tires purchased.*

**GOODYEAR BIAS PLY — WIDE BASE SIZES**

Industry Code	Tread Design	E-2			E-3								
		SGL E/L-2A			HRL E/L-3A			HRL-3A			HRL-3F		
Custom Code		2S	4S	6S	2S	4S	6S	2S	4S	6S	2S	4S	6S
20.5-25	TKPH	—	—	—	—	—	—	—	65	—			
23.5-25	TKPH	—	—	—	—	—	—	—	70	—			
26.5-25	TKPH												
29.5-25	TKPH							—	115	—			
26.5-29	TKPH												
29.5-29	TKPH							175	125	—			
33.5-33	TKPH										—	160	—
37.5-33	TKPH										—	210	—
33.25-35	TKPH										—	160	—
37.25-35	TKPH										—	210	—
29.5-35	TKPH												
37.5-39	TKPH										—	225	—

**TKPH RATINGS  
AT 38° C (100° F) AMBIENT TEMPERATURE  
For Haul Lengths of 32 km (20 miles) or Less One Way  
Maximum Speed Not to Exceed 48 km (30 miles) per Hour**

*Because of the variance between specific tires it is recommended that at the time of purchase you check with your tire supplier for the manufacturer's specific TKPH ratings for the tires purchased.*

**GOODYEAR BIAS PLY — 65 SERIES SIZES**

Industry Code	Tread Design	E-4		
		NRL D/L-4A		
Custom Code		2S	4S	6S
35/65-33	TKPH	115	95	75

**TKPH RATINGS**  
**AT 38° C (100° F) AMBIENT TEMPERATURE**  
**For Haul Lengths of 32 km (20 miles) or Less One Way**  
**Maximum Speed Not to Exceed 48 km (30 miles) per Hour**

*Because of the variance between specific tires it is recommended that at the time of purchase you check with your tire supplier for the manufacturer's specific TKPH ratings for the tires purchased.*

**BRIDGESTONE RADIAL PLY — CONVENTIONAL SIZES**

Industry Code	E-2								E-3												
	VFT			VHS		VKT			VSB	VEL			VMT			VRL					
	3A	1A	2A	3A	1A	3A	1A	2A	2A	3A	1A	2A	3A	1A	2A	3A	1A	2A			
11.00R20	TKPH																				
12.00R20	TKPH																				
16.00R20	TKPH																				
12R22.5	TKPH																				
12.00R24	TKPH																				
13.00R24	TKPH																				
14.00R24	TKPH								—	—											
16.00R24	TKPH																				
14.00R25	TKPH									—											
16.00R25	TKPH																				
18.00R25	TKPH		183					183		—	—	—									
21.00R25	TKPH																				
18.00R33	TKPH	328	281	227				328	281	227			307	263	213			307	263	213	
21.00R33	TKPH																				
21.00R35	TKPH													351	284				351	284	
24.00R35	TKPH													524	448				524	448	
24.00R49	TKPH		562	455				445	562												
27.00R49	TKPH	804	688	557				804	688	557			753	644	521				753	644	521
30.00R51	TKPH				1171	1001										1065	897				
33.00R51	TKPH															1209	1018	837			
36.00R51	TKPH				—											1407	1185	974			
37.00R57	TKPH																				
40.00R57	TKPH															1739	1463	1204			

**NOTE:** For cycle lengths of 5 km (3 miles) or less (round trip), multiply the TKPH value in this table by 1.12.  
Additional tread compounds are available to meet specific TKPH.

**TKPH RATINGS**  
**AT 38° C (100° F) AMBIENT TEMPERATURE**  
**For Haul Lengths of 32 km (20 miles) or Less One Way**  
**Maximum Speed Not to Exceed 48 km (30 miles) per Hour**

*Because of the variance between specific tires it is recommended that at the time of purchase you check with your tire supplier for the manufacturer's specific TKPH ratings for the tires purchased.*

**BRIDGESTONE RADIAL PLY – CONVENTIONAL SIZES**

Industry Code	Tread Design	Custom Code	E-4														
			L317	VELS			VELSL		VMTP			VMTS			VRDP		
			–	3A	1A	2A	3A	1A	3A	1A	2A	3A	1A	2A	3A	1A	2A
11.00R20	TKPH		188														
12.00R20	TKPH		208														
16.00R20	TKPH																
12R22.5	TKPH		188														
12.00R24	TKPH		177							136							
13.00R24	TKPH																
14.00R24	TKPH					85						136	119	91			
16.00R24	TKPH																
14.00R25	TKPH					85						136	119	91			
16.00R25	TKPH				146	112								123			
18.00R25	TKPH				179	144						244	209	169			
21.00R25	TKPH																
18.00R33	TKPH			246	211	170			267	229	185	287	246	199			
21.00R33	TKPH				281	227			–	–	–						
21.00R35	TKPH			328	281	227				293	237	383	328	265			
24.00R35	TKPH			453	388	314				388	314	489	418	338			
24.00R49	TKPH			492	421	341			552		361	575	492	398			
27.00R49	TKPH			600	513	415			636	544	440	702	600	486	600	513	415
30.00R51	TKPH			717	603	496											
33.00R51	TKPH			807	679	558			855	700	591				807	679	558
36.00R51	TKPH			927	781	642											
37.00R57	TKPH			1003	845	694	1148										
40.00R57	TKPH			1117	940	773	1330	1050							1117	940	773

**NOTE:** For cycle lengths of 5 km (3 miles) or less (round trip), multiply the TKPH value in this table by 1.12.  
Additional tread compounds are available to meet specific TKPH.

**TKPH RATINGS**  
**AT 38° C (100° F) AMBIENT TEMPERATURE**  
**For Haul Lengths of 32 km (20 miles) or Less One Way**  
**Maximum Speed Not to Exceed 48 km (30 miles) per Hour**

*Because of the variance between specific tires it is recommended that at the time of purchase you check with your tire supplier for the manufacturer's specific TKPH ratings for the tires purchased.*

**BRIDGESTONE RADIAL PLY — CONVENTIONAL SIZES**

Industry Code	E-4											E-7
	Tread Design	VREP	VRLS			VRPS			VRQP	VZTS		
Custom Code	—	3A	1A	2A	3A	1A	2A	2ALS	3A	1A	2A	—
11.00R20	TKPH											
12.00R20	TKPH											
16.00R20	TKPH											—
12R22.5	TKPH											
12.00R24	TKPH											
13.00R24	TKPH											
14.00R24	TKPH				85							
16.00R24	TKPH											
14.00R25	TKPH				85							
16.00R25	TKPH			146	112							
18.00R25	TKPH											
21.00R25	TKPH											—
18.00R33	TKPH		246	211	170			122				
21.00R33	TKPH			281	227							
21.00R35	TKPH		328	281	227							
24.00R35	TKPH		453	388	314			207				
24.00R49	TKPH		492	421	341							
27.00R49	TKPH	—	600	513	415							
30.00R51	TKPH		717	603	496							
33.00R51	TKPH		807	679	558							
36.00R51	TKPH		927	781	642							
37.00R57	TKPH		1003	845	694				1003	845	694	
40.00R57	TKPH		1117	940	773	—	—	—	1117	940	773	

**NOTE:** For cycle lengths of 5 km (3 miles) or less (round trip), multiply the TKPH value in this table by 1.12.  
Additional tread compounds are available to meet specific TKPH.



**TKPH RATINGS**  
**AT 38° C (100° F) AMBIENT TEMPERATURE**  
**For Haul Lengths of 32 km (20 miles) or Less One Way**  
**Maximum Speed Not to Exceed 48 km (30 miles) per Hour**

*Because of the variance between specific tires it is recommended that at the time of purchase you check with your tire supplier for the manufacturer's specific TKPH ratings for the tires purchased.*

**BRIDGESTONE RADIAL PLY — WIDE BASE SIZES**

Industry Code	E-2			E-3								E-4	
	TKPH			VJT		VLT		VMT		VRL		VLTS	VSNT
	3A	1A	2A	1A	2A	1A	2A	1A	2A	1A	2A	2A	2A
15.5R25 TKPH													
17.5R25 TKPH			95					—					
20.5R25 TKPH		166	129	—			—					—	
23.5R25 TKPH		263	205	248	190		190	248	190			161	
26.5R25 TKPH		312	257	293	220		220	293	220			186	165
29.5R25 TKPH	420	376	310	354	266		266	354	266			225	220
29.5R29 TKPH		401	330										232
33.25R29 TKPH		494	407			476	349			435	319		
37.5R33 TKPH		648											
29.5R35 TKPH										380			
33.25R35 TKPH			441							472	346		
37.25R35 TKPH	720	644	530			569	417			563	413		
37.5R39 TKPH		696								608			

**NOTE:** For cycle lengths of 5 km (3 miles) or less (round trip), multiply the TKPH value in this table by 1.12.  
 Additional tread compounds are available to meet specific TKPH.

**TKPH RATINGS**  
**AT 38° C (100° F) AMBIENT TEMPERATURE**  
**For Haul Lengths of 32 km (20 miles) or Less One Way**  
**Maximum Speed Not to Exceed 48 km (30 miles) per Hour**

*Because of the variance between specific tires it is recommended that at the time of purchase you check with your tire supplier for the manufacturer's specific TKPH ratings for the tires purchased.*

**BRIDGESTONE RADIAL PLY — 95 SERIES SIZES**

Industry Code	E-2					E-3	
	VFT		VKT		VSB	VEL	
Custom Code	1A	2A	1A	2A	2A	1A	2A
385/95R24 TKPH	141	106	141	106	179		
385/95R25 TKPH							
505/95R25 TKPH	239	193	239	193		224	181

**NOTE:** For cycle lengths of 5 km (3 miles) or less (round trip), multiply the TKPH value in this table by 1.12.  
Additional tread compounds are available to meet specific TKPH.

**TKPH RATINGS**  
**AT 38° C (100° F) AMBIENT TEMPERATURE**  
**For Haul Lengths of 32 km (20 miles) or Less One Way**  
**Maximum Speed Not to Exceed 48 km (30 miles) per Hour**

*Because of the variance between specific tires it is recommended that at the time of purchase you check with your tire supplier for the manufacturer's specific TKPH ratings for the tires purchased.*

**BRIDGESTONE RADIAL PLY — 90 SERIES SIZES**

Industry Code	E-4												
	VELS			VRDP			VRLS			VRPS			VZTP
Custom Code	3A	1A	2A	3A	1A	2A	3A	1A	2A	3A	1A	2A	2ALS
21/90R33 TKPH	246	211	170				246	211	170				
31/90R49 TKPH	618	528	427				618	528	427				
42/90R57 TKPH				1033	870	715							
46/90R57 TKPH	1150	968	796	1150	968	796	1150	968	796	—	—	—	585
50/90R57 TKPH	1278	1092	884				1278	1092	884	—	—	—	

**NOTE:** For cycle lengths of 5 km (3 miles) or less (round trip), multiply the TKPH value in this table by 1.12.  
Additional tread compounds are available to meet specific TKPH.

**TKPH RATINGS  
AT 38° C (100° F) AMBIENT TEMPERATURE  
For Haul Lengths of 32 km (20 miles) or Less One Way  
Maximum Speed Not to Exceed 48 km (30 miles) per Hour**

*Because of the variance between specific tires it is recommended that at the time of purchase you check with your tire supplier for the manufacturer's specific TKPH ratings for the tires purchased.*

**BRIDGESTONE RADIAL PLY — 80 SERIES SIZES**

Industry Code	E-2			E-3								
	VKT			VJT		VLT	VMT		VRD		VRF	
Custom Code	3A	1A	2A	1A	2A	2A	1A	2A	3A	1A	3A	1A
335/80R20 TKPH												
365/80R20 TKPH												
445/80R25 TKPH				144			144					
525/80R25 TKPH	232	206	160	194	149	149	194	149				
53/80R63 TKPH											—	—
55/80R63 TKPH												
59/80R63 TKPH									—	—	—	—

**NOTE:** For cycle lengths of 5 km (3 miles) or less (round trip), multiply the TKPH value in this table by 1.12.  
Additional tread compounds are available to meet specific TKPH.

**BRIDGESTONE RADIAL PLY — 80 SERIES SIZES**

Industry Code	E-4									
	VLTS	VRDP			VRLS			VRPS		
Custom Code	2A	3A	1A	2A	3A	1A	2A	3A	1A	2A
335/80R20 TKPH										
365/80R20 TKPH										
445/80R25 TKPH										
525/80R25 TKPH	126									
53/80R63 TKPH		1408	1150	974	1512	1233	1045	—	—	—
55/80R63 TKPH		1643	1341	1137						
59/80R63 TKPH		*	*	*					—	—

\*Consult Bridgestone Representative.

**NOTE:** For cycle lengths of 5 km (3 miles) or less (round trip), multiply the TKPH value in this table by 1.12.  
Additional tread compounds are available to meet specific TKPH.

**TKPH RATINGS**  
**AT 38° C (100° F) AMBIENT TEMPERATURE**  
**For Haul Lengths of 32 km (20 miles) or Less One Way**  
**Maximum Speed Not to Exceed 48 km (30 miles) per Hour**

*Because of the variance between specific tires it is recommended that at the time of purchase you check with your tire supplier for the manufacturer's specific TKPH ratings for the tires purchased.*

**BRIDGESTONE RADIAL PLY — 75 SERIES SIZES**

Industry Code	E-3				
Tread Design	VLT		VRL		
Custom Code	1A	2A	3A	1A	2A
40.5/75R39 TKPH	682	500	765	675	495

**NOTE:** For cycle lengths of 5 km (3 miles) or less (round trip), multiply the TKPH value in this table by 1.12.  
Additional tread compounds are available to meet specific TKPH.

**TKPH RATINGS**  
**AT 38° C (100° F) AMBIENT TEMPERATURE**  
**For Haul Lengths of 32 km (20 miles) or Less One Way**  
**Maximum Speed Not to Exceed 48 km (30 miles) per Hour**

*Because of the variance between specific tires it is recommended that at the time of purchase you check with your tire supplier for the manufacturer's specific TKPH ratings for the tires purchased.*

**BRIDGESTONE RADIAL PLY — 65 SERIES SIZES**

Industry Code	E-2	E-3		E-4	
Tread Design	VKT	VLT	VTS	VLTS	VSNT
Custom Code	2A	2A	—	2A	2A
25/65R25 TKPH	162				
30/65R25 TKPH		225		195	
550/65R25 TKPH			—		
600/65R25 TKPH					
650/65R25 TKPH			—		
750/65R25 TKPH		—	—	195	
775/65R29 TKPH			—		
875/65R29 TKPH			—		
35/65R33 TKPH					250

**NOTE:** For cycle lengths of 5 km (3 miles) or less (round trip), multiply the TKPH value in this table by 1.12.  
Additional tread compounds are available to meet specific TKPH.

**TKPH RATINGS**  
**AT 38° C (100° F) AMBIENT TEMPERATURE**  
**For Haul Lengths of 32 km (20 miles) or Less One Way**  
**Maximum Speed Not to Exceed 48 km (30 miles) per Hour**

*Because of the variance between specific tires it is recommended that at the time of purchase you check with your tire supplier for the manufacturer's specific TKPH ratings for the tires purchased.*

**BRIDGESTONE BIAS PLY — CONVENTIONAL SIZES**

Industry Code	E-3			E-4		E-7
	RL		WL	ELS2	RLS	SCP2
Custom Code	1A	2A	—	IDU	2A	—
9.00-20 TKPH			—			
10.00-20 TKPH	—	—				
11.00-20 TKPH	—	—				
12.00-20 TKPH	—	—				
14.00-20 TKPH						—
12.00-24 TKPH	—	—				
14.00-24 TKPH	—	—			—	
16.00-25 TKPH	—	—			—	
18.00-25 TKPH	—	—		—	—	
18.00-33 TKPH				—	—	
21.00-35 TKPH				—		

**NOTE:** For cycle lengths of 5 km (3 miles) or less (round trip), multiply the TKPH value in this table by 1.12.  
Additional tread compounds are available to meet specific TKPH.

**BRIDGESTONE BIAS PLY — CONVENTIONAL SIZES**

Industry Code	E-3			E-4
	RL		VL2	RLS
Custom Code	1A	2A	—	2A
20.5-25 TKPH			—	
23.5-25 TKPH			—	—
26.5-25 TKPH			—	—
29.5-25 TKPH			—	—
37.25-35 TKPH	—	—		

**NOTE:** For cycle lengths of 5 km (3 miles) or less (round trip), multiply the TKPH value in this table by 1.12.  
Additional tread compounds are available to meet specific TKPH.

**TKPH RATINGS**  
**AT 38° C (100° F) AMBIENT TEMPERATURE**  
**For Haul Cycles Less than 5 km (3 miles) Round Trip**

*Because of the variance between specific tires it is recommended that at the time of purchase you check with your tire supplier for the manufacturer's specific TKPH ratings for the tires purchased.*

**MICHELIN RADIAL PLY – CONVENTIONAL SIZES**

Industry Code	Tread Design	E-2						E-3						
		XHM	XL	XMH	XSNO+	XV	XZL	XDC			XDM		XK	
Custom Code		—	B	—	—	C	—	C4	B	B4	C	C4	B	A
16.00R20	TKPH						—							
24R20.5	TKPH													
24R21	TKPH						—							
12.00R24	TKPH													
14.00R24	TKPH	—			—									—
14.00R25	TKPH			232										
16.00R25	TKPH		—										187	
18.00R25	TKPH					284							237	
21.00R25	TKPH													
18.00R33	TKPH					436								
21.00R33	TKPH													
21.00R35	TKPH													
24.00R35	TKPH					740								
24.00R49	TKPH													
27.00R49	TKPH					1090								
30.00R51	TKPH													
33.00R51	TKPH							1395	1209	1054				
36.00R51	TKPH							1480	1369	1258				
37.00R57	TKPH													
40.00R57	TKPH							1920	1776	1632	1584	1440		

**NOTE:** Consult Michelin for TKPH rating on haul cycles greater than 5 km (3 miles).  
Additional tread compounds are available to meet specific TKPH.

**TKPH RATINGS  
AT 38° C (100° F) AMBIENT TEMPERATURE  
For Haul Cycles Less than 5 km (3 miles) Round Trip**

*Because of the variance between specific tires it is recommended that at the time of purchase you check with your tire supplier for the manufacturer's specific TKPH ratings for the tires purchased.*

**MICHELIN RADIAL PLY – CONVENTIONAL SIZES**

Industry Code	E-3			E-4						
	XR B	XZH	X-TRACTION S	XDM		XDR				
Tread Design										
Custom Code	B	—	B	B	B4	C	C4	B	B4	A
16.00R20 TKPH										
24R20.5 TKPH										
24R21 TKPH										
12.00R24 TKPH		119								
14.00R24 TKPH										
14.00R25 TKPH										
16.00R25 TKPH										
18.00R25 TKPH										
21.00R25 TKPH										
18.00R33 TKPH	305									
21.00R33 TKPH										
21.00R35 TKPH										
24.00R35 TKPH										
24.00R49 TKPH								453	384	
27.00R49 TKPH			763					567	480	392
30.00R51 TKPH								643	536	
33.00R51 TKPH							837	744	620	496
36.00R51 TKPH								888	740	
37.00R57 TKPH				1018	848	1272	1145	1018	848	
40.00R57 TKPH						1440	1296	1152	960	

**NOTE:** Consult Michelin for TKPH rating on haul cycles greater than 5 km (3 miles).  
Additional tread compounds are available to meet specific TKPH.

**TKPH RATINGS**  
**AT 38° C (100° F) AMBIENT TEMPERATURE**  
**For Haul Cycles Less than 5 km (3 miles) Round Trip**

*Because of the variance between specific tires it is recommended that at the time of purchase you check with your tire supplier for the manufacturer's specific TKPH ratings for the tires purchased.*

**MICHELIN RADIAL PLY – CONVENTIONAL SIZES**

Industry Code	Tread Design	Custom Code	E-4														
			XDR+				XDR2				XDT			XH D1			
			C	C4	B	B4	C	C4	B	B4	A	B	A	A4	B	A	A4
16.00R20	TKPH																
24R20.5	TKPH																
24R21	TKPH																
12.00R24	TKPH																
14.00R24	TKPH																
14.00R25	TKPH															102	84
16.00R25	TKPH															164	
18.00R25	TKPH														222	163	133
21.00R25	TKPH																
18.00R33	TKPH											262		157			
21.00R33	TKPH																
21.00R35	TKPH											348		209			
24.00R35	TKPH											444	326	226			
24.00R49	TKPH																
27.00R49	TKPH								567	480	392	654	480	392			
30.00R51	TKPH																
33.00R51	TKPH							837	744	620		930	682				
36.00R51	TKPH																
37.00R57	TKPH					1272	1145	1018	848								
40.00R57	TKPH	1440	1296	1152	960	1440	1296	1152	960								

**NOTE:** Consult Michelin for TKPH rating on haul cycles greater than 5 km (3 miles).  
Additional tread compounds are available to meet specific TKPH.



**TKPH RATINGS  
AT 38° C (100° F) AMBIENT TEMPERATURE  
For Haul Cycles Less than 5 km (3 miles) Round Trip**

*Because of the variance between specific tires it is recommended that at the time of purchase you check with your tire supplier for the manufacturer's specific TKPH ratings for the tires purchased.*

**MICHELIN RADIAL PLY – CONVENTIONAL SIZES**

Industry Code	E-4										E-7
	XK D1	X-HAUL	X-HAUL S	X-QUARRY	X-QUARRY S	X-TRACTION			X-TRACTION S		XS
Custom Code	A	—	—	—	—	B	B4	A4	C	B	—
16.00R20 TKPH											
24R20.5 TKPH											—
24R21 TKPH											
12.00R24 TKPH											
14.00R24 TKPH	84										
14.00R25 TKPH											
16.00R25 TKPH				93							
18.00R25 TKPH	133										—
21.00R25 TKPH											—
18.00R33 TKPH		262			166		218				
21.00R33 TKPH			280				280				
21.00R35 TKPH	209			122							
24.00R35 TKPH	385	355		207	281		370		281		
24.00R49 TKPH											
27.00R49 TKPH						654	567	392		763	
30.00R51 TKPH											
33.00R51 TKPH											
36.00R51 TKPH											
37.00R57 TKPH											
40.00R57 TKPH											

**NOTE:** Consult Michelin for TKPH rating on haul cycles greater than 5 km (3 miles).  
Additional tread compounds are available to meet specific TKPH.

**TKPH RATINGS  
AT 38° C (100° F) AMBIENT TEMPERATURE  
For Haul Cycles Less than 5 km (3 miles) Round Trip**

*Because of the variance between specific tires it is recommended that at the time of purchase you check with your tire supplier for the manufacturer's specific TKPH ratings for the tires purchased.*

**MICHELIN RADIAL PLY – WIDE BASE SIZES**

Industry Code	E-2			E-3		E-4			E-7
	XG	XL	XSNO+	XADN	XTS	XADT	XRS	X-SUPER TERRAIN	XS
Custom Code	C	B	—	—	—	—	B	—	—
17.5R25 TKPH	—		—						
20.5R25 TKPH			—	—		—			
23.5R25 TKPH		—	—	—				—	
26.5R25 TKPH		—		—				—	
29.5R25 TKPH				—				—	—
29.5R29 TKPH					348				
33.25R29 TKPH					429				
29.5R35 TKPH					371				
37.25R35 TKPH					540		415		
37.5R39 TKPH							453		

**NOTE:** Consult Michelin for TKPH rating on haul cycles greater than 5 km (3 miles).  
Additional tread compounds are available to meet specific TKPH.

**TKPH RATINGS**  
**AT 38° C (100° F) AMBIENT TEMPERATURE**  
**For Haul Cycles Less than 5 km (3 miles) Round Trip**

*Because of the variance between specific tires it is recommended that at the time of purchase you check with your tire supplier for the manufacturer's specific TKPH ratings for the tires purchased.*

**MICHELIN RADIAL PLY – 95 SERIES SIZES**

Industry Code	E-2			
	XL	S	XSNO+	XV
Custom Code	B	—	—	C
385/95R24 TKPH		—	—	
385/95R25 TKPH		—	—	
445/95R25 TKPH	—			
505/95R25 TKPH				284

**NOTE:** Consult Michelin for TKPH rating on haul cycles greater than 5 km (3 miles).  
Additional tread compounds are available to meet specific TKPH.

**TKPH RATINGS**  
**AT 38° C (100° F) AMBIENT TEMPERATURE**  
**For Haul Cycles Less than 5 km (3 miles) Round Trip**

*Because of the variance between specific tires it is recommended that at the time of purchase you check with your tire supplier for the manufacturer's specific TKPH ratings for the tires purchased.*

**MICHELIN RADIAL PLY – 90 SERIES SIZES**

Industry Code	E-4		
	XDR		
Custom Code	C4	B	B4
50/90R57 TKPH	1747	1498	1248

**NOTE:** Consult Michelin for TKPH rating on haul cycles greater than 5 km (3 miles).  
Additional tread compounds are available to meet specific TKPH.

**TKPH RATINGS  
AT 38° C (100° F) AMBIENT TEMPERATURE  
For Haul Cycles Less than 5 km (3 miles) Round Trip**

*Because of the variance between specific tires it is recommended that at the time of purchase you check with your tire supplier for the manufacturer's specific TKPH ratings for the tires purchased.*

**MICHELIN RADIAL PLY – 80 SERIES SIZES**

Industry Code	E-2	E-3			E-4								
		XL	XDR S		XMP	XDR				XDR2			
Tread Design													
Custom Code	B	C4	B	—	C4	B	B4	A	C4	B	B4	A	
395/80R25 TKPH				180									
525/80R25 TKPH	—												
50/80R57 TKPH					1394	1286	1072						
53/80R63 TKPH					1837	1574	1312		1837	1574	1312		
56/80R63 TKPH		2765	2458		2150	1843	1536						
59/80R63 TKPH		2535	2218		2218	1901	1584	1267	2218	1901	1584	1267	

**NOTE:** Consult Michelin for TKPH rating on haul cycles greater than 5 km (3 miles).  
Additional tread compounds are available to meet specific TKPH.

**TKPH RATINGS  
AT 38° C (100° F) AMBIENT TEMPERATURE  
For Haul Cycles Less than 5 km (3 miles) Round Trip**

*Because of the variance between specific tires it is recommended that at the time of purchase you check with your tire supplier for the manufacturer's specific TKPH ratings for the tires purchased.*

**MICHELIN RADIAL PLY – 75 SERIES SIZES**

Industry Code	E-3	
	XMS	
Tread Design		
Custom Code	B	A
40.5/75R39 TKPH	766	500

**NOTE:** Consult Michelin for TKPH rating on haul cycles greater than 5 km (3 miles).  
Additional tread compounds are available to meet specific TKPH.

**TKPH RATINGS**  
**AT 38° C (100° F) AMBIENT TEMPERATURE**  
**For Haul Cycles Less than 5 km (3 miles) Round Trip**

*Because of the variance between specific tires it is recommended that at the time of purchase you check with your tire supplier for the manufacturer's specific TKPH ratings for the tires purchased.*

**MICHELIN RADIAL PLY – 65 SERIES SIZES**

Industry Code		E-3	E-4	E-7
Tread Design		XAD 65	XTXL	XS
Custom Code		—	—	—
525/65R20.5	<b>TKPH</b>			—
650/65R25	<b>TKPH</b>	—		
750/65R25	<b>TKPH</b>	—		
850/65R25	<b>TKPH</b>	—		
775/65R29	<b>TKPH</b>	—		
875/65R29	<b>TKPH</b>	—		
35/65R33	<b>TKPH</b>		250	

**NOTE:** Consult Michelin for TKPH rating on haul cycles greater than 5 km (3 miles).  
 Additional tread compounds are available to meet specific TKPH.

**ISO LOAD INDEX SPEED SYMBOL  
AT 38° C (100° F) AMBIENT TEMPERATURE  
For Haul Cycles Greater than 5 km (3 miles) Round Trip**

*Because of the variance between specific tires it is recommended that at the time of purchase you check with your tire supplier for the manufacturer's specific TKPH ratings for the tires purchased.*

**MICHELIN RADIAL PLY — CONVENTIONAL SIZES**

Industry Code	E-2			E-7
Tread Design	XL	XV	XZL	XS
Custom Code	B	C	—	—
16.00R20			173G	
24R20.5				176F
24R21			176G	
16.00R25	177E			
18.00R25		186E		—

**ISO LOAD INDEX SPEED SYMBOL  
AT 38° C (100° F) AMBIENT TEMPERATURE  
For Haul Cycles Greater than 5 km (3 miles) Round Trip**

*Because of the variance between specific tires it is recommended that at the time of purchase you check with your tire supplier for the manufacturer's specific TKPH ratings for the tires purchased.*

**MICHELIN RADIAL PLY — WIDE BASE SIZES**

Industry Code	E-2	E-3	E-4		E-7
Tread Design	XL	XADN	XADT	X-SUPER TERRAIN	XS
Custom Code	B	—	—	—	—
20.5R25		177B	177B		
23.5R25	188E	185B*		185B	
26.5R25	195E	193B*		193B	
29.5R25		200E*		200B	196E

\*Speed option available via special field request.

**ISO LOAD INDEX SPEED SYMBOL  
AT 38° C (100° F) AMBIENT TEMPERATURE  
For Haul Cycles Greater than 5 km (3 miles) Round Trip**

*Because of the variance between specific tires it is recommended that at the time of purchase you check with your tire supplier for the manufacturer's specific TKPH ratings for the tires purchased.*

**MICHELIN RADIAL PLY – 95 SERIES SIZES**

Industry Code	E-2			
Tread Design	XL	S	XSNO+	XV
Custom Code	B	—	—	C
385/95R24		170E	170E	
385/95R25		170E	170E	
445/95R25	177E			
505/95R25				183E

**ISO LOAD INDEX SPEED SYMBOL  
AT 38° C (100° F) AMBIENT TEMPERATURE  
For Haul Cycles Greater than 5 km (3 miles) Round Trip**

*Because of the variance between specific tires it is recommended that at the time of purchase you check with your tire supplier for the manufacturer's specific TKPH ratings for the tires purchased.*

**MICHELIN RADIAL PLY – 80 SERIES SIZES**

Industry Code	E-2	E-3
Tread Design	XL	XMP
Custom Code	B	—
395/80R25		165E
525/80R25	179E	

**ISO LOAD INDEX SPEED SYMBOL  
 AT 38° C (100° F) AMBIENT TEMPERATURE  
 For Haul Cycles Greater than 5 km (3 miles) Round Trip**

*Because of the variance between specific tires it is recommended that at the time of purchase you check with your tire supplier for the manufacturer's specific TKPH ratings for the tires purchased.*

**MICHELIN RADIAL PLY – 65 SERIES SIZES**

<b>Industry Code</b>	<b>E-3</b>	<b>E-7</b>
<b>Tread Design</b>	<b>XAD 65</b>	<b>XS</b>
<b>Custom Code</b>	—	—
525/65R20.5		173F
650/65R25	180B	
750/65R25	190B	
850/65R25	196B	
775/65R29	195B	
875/65R29	203B	



**TKPH RATINGS  
AT 38° C (100° F) AMBIENT TEMPERATURE  
For Haul Lengths of 32 km (20 miles) or Less One Way  
Maximum Speed Not To Exceed 48 km (30 miles) per Hour**

*Because of the variance between specific tires it is recommended that at the time of purchase you check with your tire supplier for the manufacturer's specific TKPH ratings for the tires purchased.*

**TRIANGLE RADIAL PLY – CONVENTIONAL SIZES**

Industry Code	E-2						E-3			E-4								
	TB536			TB586			TB526			TB516S			TB526S			TL558S		
Tread Design	T3	T2	T1	T3	T2	T1	T3	T2	T1	T3	T2	T1	T3	T2	T1	T3	T2	T1
Custom Code	T3	T2	T1	T3	T2	T1	T3	T2	T1	T3	T2	T1	T3	T2	T1	T3	T2	T1
14.00R24 TKPH	170	140	110	195	160	125	130	105	85	130	105	85						
14.00R25 TKPH	195	160	125	195	160	125	–	–	–	195	160	125						
16.00R25 TKPH				–	–	–										115	80	70
18.00R25 TKPH				–	–	–				–	–	–				–	–	–
18.00R33 TKPH													270	190	160			
21.00R33 TKPH													300	230	190			
21.00R35 TKPH													310	280	230			
24.00R35 TKPH													390	350	280			

**TKPH RATINGS  
AT 38° C (100° F) AMBIENT TEMPERATURE  
For Haul Lengths of 32 km (20 miles) or Less One Way  
Maximum Speed Not To Exceed 48 km (30 miles) per Hour**

*Because of the variance between specific tires it is recommended that at the time of purchase you check with your tire supplier for the manufacturer's specific TKPH ratings for the tires purchased.*

**TRIANGLE RADIAL PLY – WIDE BASE SIZES**

Industry Code	E-2						E-3									E-4					
	TB515			TM518			TB516			TL528			TL559			TL568+			TB598S		
Tread Design	T3	T2	T1	T3	T2	T1	T3	T2	T1	T3	T2	T1	T3	T2	T1	T3	T2	T1	T3	T2	T1
Custom Code	T3	T2	T1	T3	T2	T1	T3	T2	T1	T3	T2	T1	T3	T2	T1	T3	T2	T1	T3	T2	T1
17.5R25 TKPH	–	–	–				–	–	–												
20.5R25 TKPH	–	–	–				–	–	–												
23.5R25 TKPH				260	200	170	230	170	145	230	190	150							185	135	115
26.5R25 TKPH							240	190	155				–	–	–				195	150	125
29.5R25 TKPH							290	230	180										225	175	135
29.5R29 TKPH							–	–	–												
33.25R29 TKPH																–	–	–			

**TKPH RATINGS**  
**AT 38° C (100° F) AMBIENT TEMPERATURE**  
**For Haul Lengths of 32 km (20 miles) or Less One Way**  
**Maximum Speed Not To Exceed 48 km (30 miles) per Hour**

*Because of the variance between specific tires it is recommended that at the time of purchase you check with your tire supplier for the manufacturer's specific TKPH ratings for the tires purchased.*

**TRIANGLE RADIAL PLY – 65 SERIES SIZES**

Industry Code		E-3		
Tread Design		TB598		
Custom Code		T3	T2	T1
750/65R25	TKPH	250	190	130
775/65R29	TKPH	—	—	—
875/65R29	TKPH	360	285	230

**TKPH RATINGS**  
**AT 38° C (100° F) AMBIENT TEMPERATURE**  
**For Haul Lengths of 32 km (20 miles) or Less One Way**  
**Maximum Speed Not To Exceed 48 km (30 miles) per Hour**

*Because of the variance between specific tires it is recommended that at the time of purchase you check with your tire supplier for the manufacturer's specific TKPH ratings for the tires purchased.*

**EUROTIRE RADIAL PLY**

Industry Code		E-4				
Tread Design		DR004	EROCK	ETRAC	ETRAC ADT	LR004
29.5R25	TKPH				225	225
18.00R33	TKPH	192		192		
21.00R33	TKPH			240		
24.00R35	TKPH			357		
27.00R49	TKPH			512		
33.00R51	TKPH		660	660		

**NOTE:** Consult Eurotire for TKPH ratings on haul cycles greater than 5 km (3 miles).

**TKPH RATINGS**  
**AT 38° C (100° F) AMBIENT TEMPERATURE**  
**For Haul Lengths of 32 km (20 miles) or Less One Way**  
**Maximum Speed Not To Exceed 48 km (30 miles) per Hour**

*Because of the variance between specific tires it is recommended that at the time of purchase you check with your tire supplier for the manufacturer's specific TKPH ratings for the tires purchased.*

**EUROTIRE BIAS PLY**

Industry Code		E-3		E-4		
Tread Design		U-11	U-12	U-11	U-12	U-14
24.00-35	TKPH					263
27.00-49	TKPH				385	
33.00-51	TKPH		580	511	511	
36/90-51	TKPH				520	
37.00-57	TKPH			635		
40.00-57	TKPH			685		
46/90-57	TKPH	910		695		

**NOTE:** Consult Eurotire for TKPH ratings on haul cycles greater than 5 km (3 miles).

## TIRE AND RIM ASSOCIATION RATINGS

While the TKPH Rating System provides a method to determine the tire's work capacity, Tire and Rim Association Ratings provide a guide for evaluating a tire's structural capacity. These two rating systems should be used in conjunction to evaluate tire performance.

## TIRE SELECTION

Selecting the optimum tire for a given application is particularly critical for earthmoving. The machines have the capability to outperform the tires and, unless proper practices are observed, very costly premature tire failures can occur. Job conditions vary greatly throughout the world, as well as within any given job site, and selecting the optimum tire requires careful consideration of all factors involved. In general, the tire manufacturer should be consulted before making the selection for any given application. In some cases, the tire manufacturer can fabricate tires specifically tailored for a given job site.

For those applications where wear is extremely slow, especially as a result of only occasional operation throughout the year, the cheapest lightweight tire needs to be given strong consideration.

As job conditions become severe, the following factors should be evaluated in selecting a tire:

### *Transport or Load-and-carry —*

- TKPH (primary consideration)
- Minimum approved star/ply rating or greater
- Largest optional size
- Thickest tread commensurate with TKPH
- Most cut resistant tread commensurate with TKPH
- Belted construction

### *Grader —*

- Tire load rating suitable for maximum equipped machine weight (See Tire Load Worksheet on next page)
- Application specific tire (snow, construction, road maintenance, mining, general purpose, all season)
- Bias or radial based on initial cost, puncture resistance, rolling resistance, life to retread/repair

### *Loader or Dozer —*

- Minimum approved ply rating or greater
- Largest optional size
- Thickest tread
- Thickest available undertread
- Buttressed shoulder
- Most cut resistant tread
- Belted construction
- Lowest aspect ratio

All tires should be operated at the tire manufacturer's recommended inflation pressure for a given application. Inflation pressure should be checked every working day with an accurate gauge. This gauge should be checked against a known standard such as a dead weight tester at least once a month.

Excess loads may result from factors such as varying material density, field modifications to equipment, mud accumulation, load transfer, etc. Only under these conditions may the actual in service tire load exceed the rated machine load. When excess loads are encountered, cold inflation pressures **must** be increased to compensate for higher loads. Increase tire inflation pressure 2% for each 1% increase in load.

	Maximum Excess	
	Load	Pressure
Bias Ply	15%	30%
Radial Ply	7%	14%

The above loads will result in reduced tire performance and must be approved by the tire manufacturer.

The use of chains is difficult to justify except under a few conditions. Chains are very costly and heavy, and require more maintenance than most operations can provide. On some models sufficient clearance does not exist for chains with all tire combinations. Extensive modifications may be required if chains are needed for the job.

Foam filling tires is normally not recommended due to high cost and lack of local filling facilities. Its use should be confined to loader and dozer applications where penetrations occur almost daily. If foam is used be sure to adhere to recommended equivalent pressures of nitrogen and use highest available ply rating. Consult tire manufacturer for specific warranty concerns.

**Tire Load Worksheet (Motor Graders)**

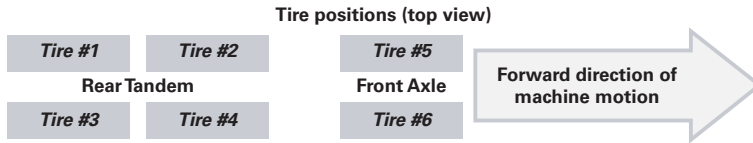

**A Machine information:**

Base operating weight (kg) (1a) = \_\_\_\_\_  
 Rear operating weight (%) (2a) = \_\_\_\_\_  
 Front operating weight (%) (3a) = \_\_\_\_\_

**B Tire loads:**

Weight on rear tire before attachments (kg) (1b) =  $(1a) \times (2a) / 4 =$  \_\_\_\_\_ (Tires # 1, 2, 3, 4)  
 Weight on front tire before attachments (kg) (2b) =  $(1a) \times (3a) / 2 =$  \_\_\_\_\_ (Tires # 5, 6)

**C Attachment information (reference Caterpillar Price List):**

Attachment Type	Tires affected	Attachment weight distribution
Ripper	1, 2, 3, 4	25% per tire
Push Block	5, 6	50% per tire
Front blade (any type)	5, 6	62% per tire
Mid-Mount Scarifier	5, 6	40% per tire
	1, 2, 3, 4	5% per tire
Snow Wing	6	34% per tire
	3, 4	55% per tire

**Attachment #1** Attachment type: \_\_\_\_\_ Attachment weight (kg) (1c) = \_\_\_\_\_  
 Tire positions affected (see chart) \_\_\_\_\_  

Tire #1	Tire #2	Tire #3	Tire #4	Tire #5	Tire #6
---------	---------	---------	---------	---------	---------

 Attachment weight distribution per tire (see chart) (2c) = \_\_\_\_\_  
 Attachment weight per tire (kg) = (1c) × (2c) (3c) = \_\_\_\_\_

**Attachment #2** Attachment type: \_\_\_\_\_ Attachment weight (kg) (4c) = \_\_\_\_\_  
 Tire positions affected (see chart) \_\_\_\_\_  

Tire #1	Tire #2	Tire #3	Tire #4	Tire #5	Tire #6
---------	---------	---------	---------	---------	---------

 Attachment weight distribution per tire (see chart) (5c) = \_\_\_\_\_  
 Attachment weight per tire (kg) = (4c) × (5c) (6c) = \_\_\_\_\_

**Attachment #3** Attachment type: \_\_\_\_\_ Attachment weight (kg) (7c) = \_\_\_\_\_  
 Tire positions affected (see chart) \_\_\_\_\_  

Tire #1	Tire #2	Tire #3	Tire #4	Tire #5	Tire #6
---------	---------	---------	---------	---------	---------

 Attachment weight distribution per tire (see chart) (8c) = \_\_\_\_\_  
 Attachment weight per tire (kg) = (7c) × (8c) (9c) = \_\_\_\_\_

**NOTE: Repeat for additional attachments if needed.**

**D Sum of attachment weights and Total weight per tire (kg)**

	Tire #1	Tire #2	Tire #3	Tire #4	Tire #5	Tire #6
--	---------	---------	---------	---------	---------	---------

(1d) = (3c) + (6c) + (9c) = \_\_\_\_\_  
 (2d) = (1d) + [(1b) or (2b)] = \_\_\_\_\_

**E Controlling tire weight = maximum value from (2d) (1e) = \_\_\_\_\_ kg**

**F Summary**

- Choose a tire with a rated load capacity equal to or greater than the controlling tire weight = Tire rating > (1f)
- Attachments may cause the maximum weight per tire to exceed tire capacity. In these cases the tire supplier should be consulted.
- Contact your tire supplier for machine specific inflation pressures to ensure compensation for different tire loads.

**TIRE SELECTION GUIDE**

Material	Road or Ground Condition	Treads		
		Haul Trucks and Wheel Tractor-Scrapers	Wheel Tractors or Wheel Loaders	Graders*
Silt and clay: – No rock – High moisture content	– Good varying to poor – High rolling resistance	E-2 (Traction)	L-2 (Traction)	G-2 (Traction)
Silt and clay: – Some rock – Variable moisture content	– Good varying to poor	E-3 (Rock) E-2 (Traction)	L-3/L-4/L-5 (Rock) L-2 (Traction)	G-3/G-4 (Rock) G-2 (Traction)
Silt/clay/gravel/sand: – Low moisture content	– Excellent to good – Firm surface	E-3/E-4 (Rock)	L-3/L-4/L-5 (Rock)	G-3/G-4 (Rock) L-3/L-4/L-5 (Rock)
Silt/clay/gravel/sand: – High moisture content	– Poor – Rutted – Pot holes	E-3/E-4 (Rock)	L-3/L-4/L-5 (Rock)	G-3/G-4 (Rock) L-3/L-4/L-5 (Rock)
Blasted rock	Hard surface, rough	E-4 (Rock)	L-5 (Rock) L-5S (Smooth)	G4 (Rock) L-4/L-5 (Rock)
Sand: – Very low silt/clay content	Good to fair surface	E-3 (Rock) E-7 (Flotation)	L-3 (Rock) L-3S (Smooth)	G-3 (Rock) Low pressure

\*NOTE: In some cases, an L type tire is appropriate for use on a Grader application, consult your tire supplier for proper tire selection.

## RECOMMENDED MOUNTING LUBRICANTS FROM SUPPLIERS

The following table documents tire supplier recommendations for Tire Mounting Compounds.

### Tire Mounting Compounds

Tire-Slick  
 Michelin “Tigre 80” Grease  
 REMA Tiptop  
 Fuchs Silkolene  
 IZY-SEEL

## TIRE SUPPLIER RECOMMENDED COLD INFLATION PRESSURES

The following tables present commonly found Caterpillar and the *tire suppliers’* recommended cold inflation pressures for tires on Cat machines. For inflation pressures of tire suppliers not listed please obtain them directly from the respected supplier.

The inflation pressure is based on a ready-to-work vehicle weight, rated payload, and average operating conditions. **Pressures for each application may need to be varied from those shown and should always be obtained from your tire supplier.**

Pressures for all tires apply to rib, traction, rock, deep tread, and super deep tread tires.

**NOTE:** Caterpillar recommends using dry nitrogen (N<sub>2</sub>) gas for both tire inflation and pressure adjustments on all current and past production machines.

## EXCAVATORS

**For complete tire data and inflation pressures, see the Excavator section in this handbook.**

*Optimal pressures may vary depending on specific applications and working conditions. Always consult your local tire supplier for operating pressures.*

## STANDARD COLD INFLATION PRESSURES SKIDDERS — Bias Ply

Model	Tire Size	Ply Rating	Inflation Pressure			
			Front		Rear	
			kPa	psi	kPa	psi
<b>525C</b>	30.5L-32	20	170	<b>25</b>	170	<b>25</b>
<b>525D</b>	30.5L-32	20	241	<b>35</b>	241	<b>35</b>
<b>535C</b>	30.5L-32	26	170	<b>25</b>	170	<b>25</b>
<b>535D</b>	30.5L-32	26	310	<b>45</b>	310	<b>45</b>
<b>545C</b>	DH35.5LB-32	20	170	<b>25</b>	170	<b>25</b>
	DH35.5LB-32	24	170	<b>25</b>	170	<b>25</b>
<b>545D</b>	35.5L-32	20	207	<b>30</b>	207	<b>30</b>
<b>555D</b>	35.5L-32	24	241	<b>35</b>	241	<b>35</b>

*Optimal pressures may vary depending on specific applications and working conditions. Always consult your local tire supplier for operating pressures.*

**SKID STEER LOADERS — Bias and Bias Belted**

Model	Tire Size	Ply Rating	Inflation Pressure									
			Galaxy Beefy Baby		Cat Premium Conventional		Cat XD (Extreme Duty)		Goodyear SGLSS		Goodyear UGL	
			kPa	psi	kPa	psi	kPa	psi	kPa	psi	kPa	psi
216B3	7-15	6			415	60						
	10-16.5	6						240	35			
	10-16.5	8	345	50	310	45						
	31x15.5-15	8								310	45	
226B3	7-15	6			415	60						
	10-16.5	6						240	35			
	10-16.5	8	345	50	310	45						
	31x15.5-15	8								310	45	
236D	10-16.5	6						240	35			
	10-16.5	8	345	50	410	60						
	10-16.5	10					345	50				
	12-16.5	10	310	45	310	44.95						
242D	10-16.5	6						240	35			
	10-16.5	8	345	50	410	60						
	10-16.5	10					345	50				
	12-16.5	10	310	45	310	44.95						
246D	12-16.5	10	310	45	310	45						
	12-16.5	14					345	50				
262D	12-16.5	10	310	45	310	45						
	12-16.5	14					345	50				
272D	12-16.5	10	310	45	310	45	310	45				
	12-16.5	14			345	50	345	50				
	14-17.5	14			415	60	415	60				
272D XHP	14-17.5	14			415	60	415	60				



*Optimal pressures may vary depending on specific applications and working conditions. Always consult your local tire supplier for operating pressures.*

**TELEHANDLERS**

Model	Tire Size	Ply Rating/Star Rating	Inflation Pressure	
			kPa	psi
TH220B	15.5/80-24	16	250	36
	17.5LR24xM27	12	310	45
	15.5-25 SGL-2A	12	410	59
TH330B	13.00-24 SGG-2ATL	12	370	54
	13.00-24 Cat	12	450	65
	440/70R24xM37 (17.5R24)	Radial	350	51
	550/70R24xM37 (19.5LR24)	Radial	350	51
	15.5-25 SGL-2A	12	320	46
	15.5-25 Cat	12	400	58
	15.5R25 XHA	Radial	400	58
TH255	12x16.5	12	551	80
	14x17.5	10	482	70
TH336 TH406	15.5/80-24 TR01	14	410	59
	15.5/80-24 SGL-2A	16	400	58
	400/80-24-400	—	400	58
	460/70R24	Radial	420	61
	15.5-25 SGL	8, 12	400	58
TH337 TH407	15.5/80-24 TR01	14	410	59
	15.5/80-24 SGL-2A	16	400	58
	400/80-24-400	—	400	58
	440/80-24-350	—	350	51
	460/70R24	Radial	420	61
	500/70R24	Radial	300	44
	15.5-25 SGL	8, 12	400	58
TH417 TH514	14.00-24 TG02	16	425	62
	14.00-24 SGG-2A	16	525	76
TL642 TL963	13.00-24	12	448	65
	13.00R24	★	482	70
	15.5-25	12	448	65
	15.5R24	★	482	70
	370/75-28	14	524	76
TL642C TL943C	13.00x24	12	448	65
	15.5-25	12	400	58
	370/75-28	14	524	76
TL1055 TL1255	14.00-24	12	448	65
	14.00R24	★	482	70
	17.5-25	12	448	65
	17.5R25	★	482	70
	400/75-28	16	524	76
TL1055C TL1255C	14.00-24	12	448	65
	17.5-25	12	448	65
	400/75-28	16	524	76

NOTE: See machine OMM for operating pressures. <http://onlineexpress2.jlg.com/CAGUI/default.aspx>.

*Optimal pressures may vary depending on specific applications and working conditions. Always consult your local tire supplier for operating pressures.*

**BACKHOE LOADERS (Front)**

Model	Tire Size	Ply/Speed Symbol	Inflation Pressure	
			kPa	psi
415F2, 416F2, 420F2, 422F2	11L-16	12 PLY	352	51
415F2, 416F2, 420F2	12-16.5	10 PLY	448	65
415F2, 416F2, 420F2, 422F2, 427F2, 428F2, 430F2, 432F2	12.5/80-18	10 PLY/12 PLY/14 PLY	317/372/310	46/54/45
422F2, 427F2, 428F2, 432F2	340/80-18	143 A8	345	50
415F2, 416F2, 420F2, 430F2	320/80R18	143 B	400	58
415F2, 416F2, 420F2, 430F2	340/80R18	143 A8	324	47
422F2, 427F2, 428F2, 432F2	340/80R18	143 A8	386	56
427F2, 428F2, 432F2	340/80-20	144 A8	324	47
427F2, 428F2, 432F2	340/80R20	144 A8	372	54
450F	15-19.5	12 PLY	414	60

**BACKHOE LOADERS (Rear)**

Model	Tire Size	Ply/Speed Symbol	Inflation Pressure	
			kPa	psi
415F2, 416F2, 420F2, 430F2	19.5L-24	12 PLY	234	34
415F2, 416F2, 420F2, 430F2	500/70R24	157 B/164 A8	317/331	46/48
415F2, 416F2, 420F2, 430F2, 450F	21L-24	16 PLY/18 PLY	276/303	40/44
434F2, 444F2	440/80-24	168 A8	317	46
434F2, 444F2	440/80R24	161 A8	324	47
427F2, 428F2, 432F2	18.4-26	12 PLY	248	36
427F2, 428F2, 432F2	480/80-26	160 A8	282	41
427F2, 428F2, 432F2	480/80R26	160 A8	282	41
422F2, 427F2, 428F2, 432F2	16.9-28	12 PLY	262	38
422F2, 427F2, 428F2, 432F2, 434F2, 444F2	440/80-28	156 A8	282	41
422F2, 427F2, 428F2, 432F2	440/80R28	156 A8/163 A8	282/317	41/46
434F2, 444F2	440/80R28	156 A8/163 A8	310/317	45/46

*Optimal pressures may vary depending on specific applications and working conditions. Always consult your local tire supplier for operating pressures.*

### PAVING PRODUCTS — Bias Ply and Radial Pneumatic Tires

Model	Tire Size	Ply Rating/Star Rating	Inflation Pressure <sup>1,2,3</sup>	
			kPa	psi
<b>WHEEL ASPHALT PAVERS</b>				
AP500E/BG500E/AP500F	17.5R25	★	448	65
AP600D/BG600D	16.00-24	12	345	50
	445/95R25	★★	551	80
AP600F	16.00-24	12	345	50
	445/95R25	174F	600	87
AP1000E/BG1000E	18.00-25	16	379	55
	445/95R25	★★	586	85
AP1000F	18.00-25	16	379	55
	20.5R25	★	434	63
<b>VIBRATORY SOIL COMPACTORS</b>				
CP44				
CS44				
CP54				
CP54B				
CS54	23.1-26	8	110	16
CS54 XT				
CS54B				
CP56	23.1-26	8	110	16
CP56B				
CS56	23.1-26	8	110	16
CS56B				
CP64	23.1-26	12	165	24
CS64	23.1-26	8	110	16
	23.1-26	12	165	24
CP68B				
CS68B				
CP74	23.1-26	8	110	16
CP74B				
CS74	23.1-26	8	110	16
	23.1-26	12	165	24
CS74B				
CP76	23.1-26	12	165	24
CS76	23.1-26	12	165	24
CS76 XT	23.1-26	12	165	24
CS78B				
<b>PNEUMATIC ROLLERS</b>				
PS150C	8.50/90x15	6	350	51
	7.50x15	12	760	110
PS360C	14/70x20	20	760	110

<sup>1</sup>Inflation pressures are maximum rated tire pressures.

<sup>2</sup>Pressure varies with application for Pneumatic Tire Compactors (PS).

<sup>3</sup>Consult your local tire supplier for operating pressures.

*Optimal pressures may vary depending on specific applications and working conditions. Always consult your local tire supplier for operating pressures.*

**MOTOR GRADERS — Bias Ply\***

Model	Tire Size	Ply Rating	Inflation Pressure											
			Bridgestone/Firestone				Goodyear				Triangle			
			Front		Center/Rear		Front		Center/Rear		Front		Center/Rear	
kPa	psi	kPa	psi	kPa	psi	kPa	psi	kPa	psi	kPa	psi	kPa	psi	
12K	13.00-24	12, 16					276	40	276	40				
	14.00-24	12, 16	248	36	248	36	200	29	200	29	248	36	276	40
	17.5-25	12, 16	248	36	248	36					248	36	276	40
12M	14.00-24	12, 16					248	36	352	51				
	17.50-25	12, 16	207	30	241	35								
12M3	14.00-24	12, 16					228	33	324	47				
	17.5-25	12, 16	207	30	241	35								
120K	13.00-24	12, 16	248	36	248	36	228	33	228	33				
	14.00-24	12, 16	248	36	248	36	172	25	172	25	248	36	276	40
	17.5-25	12, 16	248	36	248	36					248	36	276	40
120M	14.00-24	12, 16	207	30	276	40	228	33	324	47				
120M2	14.00-24	12, 16					228	33	324	47				
	17.50-25	12, 16	207	30	241	35								
140K	14.00-24	12, 16	248	36	248	36	172	25	172	25	248	36	276	40
	17.5-25	12, 16	248	36	248	36	248	36	276	40	248	36	276	40
140M	14.00-24	12, 16	207	30	241	35	248	36	352	51				
	17.50-25	12, 16	207	30	276	40								
140M3	14.00-24	12, 16					303	44	427	62				
	17.5-25	12, 16	207	30	276	40								
	17.50-25	12, 16	207	30	276	40								
160K	14.00-24	12, 16	248	36	248	36								
	17.5-25	12, 16	248	36	248	36					248	36	276	40
160M	14.00-24	12, 16					303	44	427	62				
160M3	17.5-25	12, 16	207	30	276	40								

\*Consult your local tire supplier for proper ply rating.

*Optimal pressures may vary depending on specific applications and working conditions. Always consult your local tire supplier for operating pressures.*

**MOTOR GRADERS — Radial Ply**

Model	Tire Size	Star Rating	Inflation Pressure							
			Michelin				Bridgestone/Firestone			
			Front		Center/Rear		Front		Center/Rear	
kPa	psi	kPa	psi	kPa	psi	kPa	psi			
12K	13.00R24	★, ★★					310	45	310	45
	14.00R24	★, ★★					310	45	310	45
	17.5R25	★, ★★					276	40	276	40
12M	14.00R24	★, ★★	207	30	310	45	310	45	310	45
	17.5R25	★, ★★	207	30	241	35	276	40	276	40
12M3	14.00R24	★, ★★	207	30	310	45	303	44	372	54
	17.5R25	★, ★★	207	30	241	35	241	35	303	44
14M	20.5R25	★, ★★	207	30	310	45	310	45	310	45
16M	23.5R25	★, ★★	207	30	276	40	207	30	290	42
16M3	23.5R25	★, ★★	207	30	310	45	207	30	290	42
18M3	23.5R25	★, ★★	207	30	345	50	207	30	345	50
24M	29.5R29	★, ★★	303	44	379	55	310	45	379	55
120K	13.00R24	★, ★★					310	45	310	45
	14.00R24	★, ★★					310	45	310	45
	17.5R25	★, ★★					276	40	276	40
120M	14.00R24	★, ★★	241	35	345	50	310	45	310	45
	17.5R25	★, ★★	207	30	276	40	276	40	276	40
120M2	14.00R24	★, ★★	241	35	345	50	310	45	359	52
	17.5R25	★, ★★	207	30	276	40	276	40	310	45
140K	13.00R24	★, ★★					310	45	310	45
	14.00R24	★, ★★	207	30	241	35	310	45	310	45
	17.5R25	★, ★★					276	40	276	40
140M	14.00R24	★, ★★	276	40	345	50	310	45	310	45
	17.5R25	★, ★★	207	30	276	40	276	40	276	40
140M3	14.00R24	★, ★★	276	40	345	50	303	44	372	54
	17.5R25	★, ★★	207	30	276	40	241	35	303	44
160K	13.00R24	★, ★★					310	45	310	45
	14.00R24	★, ★★					310	45	310	45
	17.5R25	★, ★★					276	40	276	40
160M	14.00R24	★, ★★	276	40	345	50	310	45	310	45
	17.5R25	★, ★★	207	30	276	40	276	40	276	40
160M3	14.00R24	★, ★★	276	40	345	50	310	45	379	55
	17.5R25	★, ★★	207	30	276	40	310	45	379	55

**NOTE:** These are general pressures. For applications such as slope and ditching service, the inflation pressures should be increased by 100 kPa (15 psi) with NO increase in carrying capacity. Any extreme conditions should be referred to your local tire supplier OR representative for recommended pressures, sizes, patterns, and compounds for specific application. The recommended inflation pressures provided are a starting point for the machine shown.

*Optimal pressures may vary depending on specific applications and working conditions. Always consult your local tire supplier for operating pressures.*

**WHEEL TRACTOR-SCRAPERS — Bias Ply**

Model	Tire Size	Ply Rating	Inflation Pressure							
			Titan				Yokohama			
			Front		Rear		Front		Rear	
kPa	psi	kPa	psi	kPa	psi	kPa	psi			
621H	33.25-29	38	400	58	400	58				
621K	33.25-29	38	414	60	345	50				
623K	33.25-29	38	414	60	345	50				
657G	37.5-39	52					448	65	448	65

**WHEEL TRACTOR-SCRAPERS — Radial Ply**

Model	Tire Size	Star Rating	Inflation Pressure							
			Michelin				Bridgestone/Firestone			
			Front		Rear		Front		Rear	
kPa	psi	kPa	psi	kPa	psi	kPa	psi			
621H	33.25R29	★★					448	65	393	57
621K	33.25R29	★★	448	65	400	58	462	67	434	63
623K	33.25R29	★★	448	65	414	60	462	67	434	63
627K	33.25R29	★★	476	69	476	69	483	70	483	70
631G	37.25R35	★★	552	80	476	69	552	80	552	80
631K	37.25R35	★★	552	80	476	69	552	80	552	80
637G	37.25R35	★★	552	80	503	73	552	80	552	80
637K	37.25R35	★★	552	80	503	73	552	80	552	80
657G	40.5/75R39	★★	600	87	524	76	621	90	621	90

*Optimal pressures may vary depending on specific applications and working conditions. Always consult your local tire supplier for operating pressures.*

**ARTICULATED TRUCKS — Radial Ply**

Model	Tire Size	Star Rating	Inflation Pressure											
			Michelin						Bridgestone/Firestone					
			Front		Center		Rear		Front		Center		Rear	
		kPa	psi	kPa	psi	kPa	psi	kPa	psi	kPa	psi	kPa	psi	
725C	23.5R25	★★	448	65	400	58	400	58	476	69	414	60	414	60
	750/65R25	★★	276	40	276	40	276	40	379	55	345	50	345	50
725C2	23.5R25	★★	448	65	400	58	400	58	476	69	414	60	414	60
	750/65R25	★★	276	40	276	40	276	40	379	55	345	50	345	50
730C	23.5R25	★★	503	73	448	65	448	65	476	69	414	60	414	60
	750/65R25	★★	303	44	352	51	352	51	524	76	490	71	490	71
730C2	23.5R25	★★	503	73	448	65	448	65	503	73	448	65	448	65
	750/65R25	★★	476	69	414	60	414	60	379	55	345	50	345	50
730C EJ	750/65R25	★★	276	40	372	54	372	54	345	50	448	65	448	65
735B	26.5R25	★★	448	65	503	73	503	73	496	72	538	78	538	78
735C	26.5R25	★★	448	65	503	73	503	73	496	72	538	78	538	78
	775/65R29	★★												
740B	29.5R25	★★	400	58	503	73	503	73	414	60	490	71	490	71
	29.5R29	★★	400	58	503	73	503	73	414	60	490	71	490	71
740C EJ	29.5R25	★★	400	58	503	73	503	73	414	60	490	71	490	71
	29.5R29	★★	400	58	503	73	503	73	414	60	490	71	490	71
	875/65R29	★★	303	44	324	47	324	47						
		★★												
745C	29.5R25	★★	400	58	503	73	503	73	483	70	496	72	496	72
	29.5R29	★★	400	58	503	73	503	73	483	70	496	72	496	72
	875/65R29	★★	324	47	331	48	331	48	379	55	393	57	393	57

Model	Tire Size	Star Rating	Inflation Pressure											
			Goodyear						Yokohama					
			Front		Center		Rear		Front		Center		Rear	
		kPa	psi	kPa	psi	kPa	psi	kPa	psi	kPa	psi	kPa	psi	
725C	23.5R25	★★							503	73	427	62	427	62
	750/65R25	★★												
725C2	23.5R25	★★							503	73	427	62	427	62
	750/65R25	★★												
730C	23.5R25	★★							524	76	490	71	490	71
	750/65R25	★★												
730C2	23.5R25	★★							379	55	345	50	345	50
	750/65R25	★★												
730C EJ	750/65R25	★★												
735B	26.5R25	★★												
735C	26.5R25	★★												
	775/65R29	★★	372	54	400	58	400	58						
740B	29.5R25	★★							448	65	524	76	524	76
	29.5R29	★★							448	65	524	76	524	76
740C EJ	29.5R25	★★							448	65	524	76	524	76
	29.5R29	★★							448	65	524	76	524	76
	875/65R29	★★												
		★★												
745C	29.5R25	★★							503	73	524	76	524	76
	29.5R29	★★							503	73	524	76	524	76
	875/65R29	★★												

Standard Cold Inflation Pressures  
 ● Mining & Off-Highway Trucks — Bias and Radial Ply

*Optimal pressures may vary depending on specific applications and working conditions. Always consult your local tire supplier for operating pressures.*

**MINING & OFF-HIGHWAY TRUCKS — Bias Ply**

Model	Tire Size	Ply Rating	Inflation Pressure											
			Goodyear				Eurotire				JK			
			Front		Rear		Front		Rear		Front		Rear	
		kPa	psi	kPa	psi	kPa	psi	kPa	psi	kPa	psi	kPa	psi	
773E	24.00-35	42	572	83	572	83	586	85	552	80	648	94	648	94
777E	27.00-49	48					648	94	648	94	655	95	655	95

**MINING & OFF-HIGHWAY TRUCKS — Radial Ply**

Model	Tire Size	Star Rating	Inflation Pressure											
			Michelin				Bridgestone/Firestone				Goodyear			
			Front		Rear		Front		Rear		Front		Rear	
		kPa	psi	kPa	psi	kPa	psi	kPa	psi	kPa	psi	kPa	psi	
770G	18.00R33	★★	758	110	758	110	800	116	800	116				
772G	21.00R33	★★	689	100	689	100	689	100	689	100				
773E	24.00R35	★★	579	84	579	84	689	100	689	100				
773G	24.00R35	★★	689	100	689	100	689	100	689	100				
775G	24.00R35	★★	689	100	689	100	689	100	689	100				
777E	27.00R49	★★	655	95	703	102	703	102	703	102				
777G	27.00R49	★★	703	102	703	102	703	102	703	102	703	102	731	106
785C	33.00R51	★★	724	105	724	105	793	115	793	115	800	116	800	116
785D	33.00R51	★★	724	105	724	105	793	115	793	115	800	116	800	116
789D	37.00R57	★★	627	91	627	91	758	110	758	110	738	107	738	107
	40.00R57	★★	552	80	552	80					627	91	627	91
793D	40.00R57	★★	724	105	724	105	724	105	724	105	752	109	752	109
	46/90R57	★★					793	115	793	115	724	105	724	105
793F	40.00R57	★★	724	105	724	105								
	46/90R57	★★					793	115	793	115	724	105	724	105
	50/80R57	★★	669	97	669	97								
794 AC	53/80R63	★★	<i>Consult Michelin</i>				758	110	758	110	<i>Consult Goodyear</i>			
795F AC	56/80R63	★★	655	95	621	90								
	59/80R63	★★					703	102	703	102	703	102	703	102
797F	59/80R63	★★	689	100	689	100	724	105	724	105				



# Tires

## Standard Cold Inflation Pressures

### ● Mining & Off-Highway Trucks — Radial Ply

*Optimal pressures may vary depending on specific applications and working conditions. Always consult your local tire supplier for operating pressures.*

#### MINING & OFF-HIGHWAY TRUCKS — Radial Ply

Model	Tire Size	Star Rating	Inflation Pressure											
			Titan				Triangle				Eurotire			
			Front		Rear		Front		Rear		Front		Rear	
		kPa	psi	kPa	psi	kPa	psi	kPa	psi	kPa	psi	kPa	psi	
770G	18.00R33	★★												
772G	21.00R33	★★					758	110	758	110	689	100	689	100
773E	24.00R35	★★									689	100	689	100
773G	24.00R35	★★	703	102	703	102								
775G	24.00R35	★★	703	102	703	102								
777E	27.00R49	★★									703	102	703	102
777G	27.00R49	★★	703	102	703	102								
785C	33.00R51	★★												
785D	33.00R51	★★												
789D	37.00R57	★★												
	40.00R57	★★												
793D	40.00R57	★★												
	46/90R57	★★												
793F	40.00R57	★★												
	46/90R57	★★												
	50/80R57	★★												
794 AC	53/80R63	★★												
795F AC	56/80R63	★★												
	59/80R63	★★												
797F	59/80R63	★★												

*Optimal pressures may vary depending on specific applications and working conditions. Always consult your local tire supplier for operating pressures.*

**WHEEL LOADERS — Bias and Bias Belted**

Model	Tire Size	Ply Rating	Inflation Pressure												
			Goodyear		Bridgestone/Firestone		Yokohama								
			Front	Rear	Front	Rear	Front	Rear							
			kPa	psi	kPa	psi	kPa	psi	kPa	psi	kPa	psi			
910K, 910M	16.9-24	10, 12										250/ 280*	36/ 41*	190/ 225*	28/ 33*
910K, 910M	15.5-25	12	225/ 250**	33/ 36**	200	29									
914K, 914M, 918M	17.5-25	12, 16	225	33	200	29	240	35	210	30					

\*Yokohama (16.9-24) recommends 250/190 kPa (36/28 psi) front/rear pressures for 910K/M Standard Lift, 280/225 kPa (41/33 psi) front/rear pressures for 910K/M High Lift.

\*\*Goodyear (15.5-25) recommends 225/200 kPa (33/29 psi) front/rear pressures for 910K/M Standard Lift, 250/200 kPa (36/29 psi) front/rear pressures for 910K/M High Lift.

*Optimal pressures may vary depending on specific applications and working conditions. Always consult your local tire supplier for operating pressures.*

**WHEEL LOADERS — Bias and Bias Belted**

Model	Tire Size	Ply Rating	Inflation Pressure							
			Bridgestone/Firestone				Titan			
			Front		Rear		Front		Rear	
		kPa	psi	kPa	psi	kPa	psi	kPa	psi	
<b>924K</b>	17.5-25	16	483	70	310	45	448	65	379	55
	20.5-25	12								
	20.5-25	16	379	55	310	45				
	20.5-25	20								
	28L-26	26	393	57	241	35				
<b>930K</b>	17.5-25	16	483	70	345	50				
	20.5-25	12								
	20.5-25	16	414	60	345	50				
	20.5-25	20					448	65	379	55
	28L-26	26	393	57	241	35				
<b>938K</b>	20.5-25	12								
	20.5-25	14								
	20.5-25	16	414	60	310	45				
	20.5-25	20					448	65	379	55
	28L-26	26	393	57	241	35				
<b>926M</b>	17.5-25	16	483	70	345	50				
	20.5-25	12								
	20.5-25	16	379	55	310	45				
	20.5-25	20					448	65	379	55
	28L-26	24	393	57	241	35				
<b>930M</b>	17.5-25	16	483	70	345	50				
	20.5-25	12								
	20.5-25	16	414	60	310	45				
	20.5-25	20					448	65	379	55
	28L-26	26	393	57	241	35				
<b>938M</b>	20.5-25	12								
	20.5-25	14								
	20.5-25	16	414	60	310	45				
	20.5-25	20					448	65	379	55
	28L-26	26	393	57	241	35				

For pressures not listed, consult your local tire supplier for operating pressures.

*Optimal pressures may vary depending on specific applications and working conditions. Always consult your local tire supplier for operating pressures.*

**WHEEL LOADERS — Bias and Bias Belted**

Model	Tire Size	Ply Rating	Inflation Pressure															
			Bridgestone/Firestone				Goodyear				Titan				Triangle			
			Front		Rear		Front		Rear		Front		Rear		Front		Rear	
kPa	psi	kPa	psi	kPa	psi	kPa	psi	kPa	psi	kPa	psi	kPa	psi	kPa	psi	kPa	psi	
950H	23.5-25	16, 20	345	50	207	30	400	58	276	40								
950M	23.5-25	16, 20	379	55	310	45												
962H	23.5-25	16, 20	379	55	310	45	427	62	276	40								
962K	23.5-25	16, 20	379	55	310	45												
962M	23.5-25	16, 20	379	55	310	45												
966H	26.5-25	16, 20	414	60	276	40								352	51	352	51	
966K	26.5-25	16, 20	414	60	345	50												
966M	26.5-25	16, 20	414	60	345	50												
972H	26.5-25	16, 20	448	65	345	50								352	51	352	51	
972K	26.5-25	16, 20	414	60	345	50												
972M	26.5-25	16, 20	414	60	345	50												
980H	29.5-25	28	483	70	345	50								352	51	248	36	
980K	29.5-25	28	469	68	324	47												
980M	29.5-25	28	469	68	324	47												
986K	35/65-33	42	655	95	414	60												
988K	35/65-33	42	655	95	414	60												
990K	41.25/70-39	42								476	69	476	69					
992K	45/65-45	58	724	105	483	70				676	98	676	98					
993K	50/65-51	62	758	110	483	70												
994K	53.5/85-57	76	724	105	483	70												
994K	58/85-57	84	724	105	483	70												

For pressures not listed, consult your local tire supplier for operating pressures.

*Optimal pressures may vary depending on specific applications and working conditions. Always consult your local tire supplier for operating pressures.*

**WHEEL LOADERS — Radial Ply**

Model	Tire Size	Star Rating	Inflation Pressure												
			Michelin				Goodyear				Dunlop				
			Front		Rear		Front		Rear		Front		Rear		
			kPa	psi	kPa	psi	kPa	psi	kPa	psi	kPa	psi	kPa	psi	
906K/M	335/80R18														
907K/M	340/80R18 405/70R18		360	52	270	39						350	51	225	33
908K/M	360/80R20 400/70R20 405/70R20		360	52	260	38						375	54	250	36
910K/M, 914K/M, 918M	15.5R25	★	250	36	200	29									
910K/M, 914K/M, 918M	17.5R25	★	250	36	200	29	275	40	200	29					

Model	Tire Size	Star Rating	Inflation Pressure										
			Firestone				Nokian						
			Front		Rear		Front		Rear				
			kPa	psi	kPa	psi	kPa	psi	kPa	psi	kPa	psi	
906K/M	335/80R18												
907K/M	340/80R18 405/70R18		400/330*	58/48*	250	36	400	58	250	36			
908K/M	360/80R20 400/70R20 405/70R20							425	62	250	36		
910K/M, 914K/M, 918M	15.5R25	★											
910K/M, 914K/M, 918M	17.5R25	★											

\*Firestone (340/80R18) recommends 400 kPa (58 psi) @ 10 km/h (6 mph) non-cyclic load, 330 kPa (48 psi) @ 10 km/h (6 mph) cyclic load.

*Optimal pressures may vary depending on specific applications and working conditions. Always consult your local tire supplier for operating pressures.*

**WHEEL LOADERS — Radial Ply**

Model	Tire Size	Star Rating	Inflation Pressure											
			Michelin				Bridgestone				Titan			
			Front		Rear		Front		Rear		Front		Rear	
		kPa	psi	kPa	psi	kPa	psi	kPa	psi	kPa	psi	kPa	psi	
924K	17.5R25	★	427	62	303	44	483	70	345	50	503	73	379	55
	17.5R25	★★	503	73	372	54								
	20.5R25	★	303	44	228	33	414	60	345	50	503	73	379	55
	20.5R25	★★	400	58	303	44								
	550/65R25	★	352	51	248	36	414	60	345	50				
	600/65R25	★	303	44	228	33								
	650/65R25	★	303	44	228	33								
	620/75R25	★	290	42	200	29								
750/65R26	★													
930K	17.5R25	★	427	62	303	44	503	73	345	50				
	17.5R25	★★	552	80	400	58								
	20.5R25	★	324	47	248	36	503	73	345	50	503	73	379	55
	20.5R25	★★	400	58	303	44								
	550/65R25	★	400	58	303	44	414	60	310	45				
	600/65R25	★	352	51	248	36								
	650/65R25	★	352	51	248	36								
	620/75R25	★	310	45	221	32								
750/65R26	★★													
938K	17.5R25	★★	648	94	476	69								
	20.5R25	★	372	54	276	40	503	73	345	50	503	73	379	55
	20.55R25	★★	476	69	372	54								
	550/65R25	★	400	58	303	44								
	600/65R25	★	400	58	303	44								
	650/65R25	★	400	58	303	44								
	23.5R25	★												
	620/75R26	★	379	55	262	38								
750/65R26	★													

*Optimal pressures may vary depending on specific applications and working conditions. Always consult your local tire supplier for operating pressures.*

**WHEEL LOADERS — Radial Ply**

Model	Tire Size	Star Rating	Inflation Pressure											
			Michelin				Bridgestone				Titan			
			Front		Rear		Front		Rear		Front		Rear	
		kPa	psi	kPa	psi	kPa	psi	kPa	psi	kPa	psi	kPa	psi	
<b>926M</b>	17.5R25	★	427	62	303	44	483	70	345	50				
	17.5R25	★★	503	73	372	54								
	20.5R25	★	303	44	228	33	414	60	345	50	503	73	379	55
	20.5R25	★★	400	58	303	44								
	550/65R25	★	352	51	248	36	414	60	345	50				
	600/65R25	★	303	44	228	33								
	650/65R25	★	303	44	228	33								
	620/75R25	★	290	42	200	29								
750/65R26	★													
<b>930M</b>	17.5R25	★	427	62	303	44	503	73	345	50				
	17.5R25	★★	552	80	400	58								
	20.5R25	★	324	47	248	36	503	73	345	50	503	73	379	55
	20.5R25	★★	400	58	303	44								
	550/65R25	★	400	58	303	44	414	60	310	45				
	600/65R25	★	352	51	248	36								
	650/65R25	★	352	51	248	36								
	620/75R26	★	310	45	221	32								
750/65R26	★★													
<b>938M</b>	17.5R25	★★	648	94	476	69								
	20.5R25	★	372	54	276	40	503	73	345	50	503	73	379	55
	20.5R25	★★	476	69	372	54								
	550/65R25	★	400	58	303	44								
	600/65R25	★	400	58	303	44								
	650/65R25	★	400	58	303	44								
	23.5R25	★												
	620/75R26	★	379	55	262	38								
750/65R26	★													

*Optimal pressures may vary depending on specific applications and working conditions. Always consult your local tire supplier for operating pressures.*

**WHEEL LOADERS — Radial Ply**

Model	Tire Size	Star Rating	Inflation Pressure											
			Michelin				Bridgestone/Firestone				Goodyear			
			Front		Rear		Front		Rear		Front		Rear	
kPa	psi	kPa	psi	kPa	psi	kPa	psi	kPa	psi	kPa	psi			
<b>950GC</b>	23.5R25	★, ★★					448	<b>65</b>	345	<b>50</b>				
<b>950H</b>	23.5R25	★, ★★	414	<b>60</b>	241	<b>35</b>	345	<b>50</b>	207	<b>30</b>				
<b>950K</b>	23.5R25	★, ★★	414	<b>60</b>	241	<b>35</b>	483	<b>70</b>	345	<b>50</b>				
<b>950M</b>	23.5R25	★, ★★	448	<b>65</b>	248	<b>36</b>	483	<b>70</b>	345	<b>50</b>	476	<b>69</b>	303	<b>44</b>
	750/65R25	★, ★★	352	<b>51</b>	303	<b>44</b>	414	<b>60</b>	276	<b>40</b>				
<b>962H</b>	23.5R25	★, ★★	448	<b>65</b>	276	<b>40</b>	379	<b>55</b>	241	<b>35</b>				
<b>962K</b>	23.5R25	★, ★★	448	<b>65</b>	276	<b>40</b>	483	<b>70</b>	345	<b>50</b>				
<b>962M</b>	23.5R25	★, ★★	448	<b>65</b>	248	<b>36</b>	483	<b>70</b>	345	<b>50</b>	503	<b>73</b>	324	<b>47</b>
	750/65R25	★, ★★	352	<b>51</b>	207	<b>30</b>	414	<b>60</b>	276	<b>40</b>				
<b>966H</b>	26.5R25	★, ★★	414	<b>60</b>	241	<b>35</b>	414	<b>60</b>	276	<b>40</b>				
<b>966K</b>	26.5R25	★, ★★	414	<b>60</b>	241	<b>35</b>	414	<b>60</b>	276	<b>40</b>				
<b>966M</b>	26.5R25	★, ★★	414	<b>60</b>	241	<b>35</b>	448	<b>65</b>	310	<b>45</b>	524	<b>76</b>	324	<b>47</b>
	775/65R29	★, ★★					483	<b>70</b>	345	<b>50</b>				
<b>972H</b>	26.5R25	★, ★★	448	<b>65</b>	276	<b>40</b>	448	<b>65</b>	276	<b>40</b>				
<b>972K</b>	26.5R25	★, ★★	448	<b>65</b>	276	<b>40</b>	448	<b>65</b>	276	<b>40</b>				
<b>972M</b>	26.5R25	★, ★★	414	<b>60</b>	276	<b>40</b>	503	<b>73</b>	345	<b>50</b>	524	<b>76</b>	324	<b>47</b>
	775/65R29	★, ★★					483	<b>70</b>	345	<b>50</b>				
<b>980H</b>	29.5R25	★, ★★	517	<b>75</b>	276	<b>40</b>	586	<b>85</b>	379	<b>55</b>				
<b>980K</b>	29.5R25	★, ★★	517	<b>75</b>	276	<b>40</b>	586	<b>85</b>	379	<b>55</b>				
	875/65R29	★, ★★					517	<b>75</b>	379	<b>55</b>				
<b>980M</b>	29.5R25	★, ★★	517	<b>75</b>	276	<b>40</b>	586	<b>85</b>	379	<b>55</b>	724	<b>105</b>	524	<b>76</b>
	875/65R29	★, ★★	517	<b>75</b>	276	<b>40</b>	517	<b>75</b>	379	<b>55</b>				
<b>982M</b>	29.5R29	★, ★★					655	<b>95</b>	414	<b>60</b>				
	875/65R29	★, ★★	427	<b>62</b>	303	<b>44</b>	552	<b>80</b>	345	<b>50</b>				
<b>986H</b>	35/65R33	★★, ★★★	448	<b>65</b>	310	<b>45</b>	655	<b>95</b>	414	<b>60</b>				
<b>988K</b>	35/65R33	★★, ★★★	600	<b>87</b>	448	<b>65</b>	655	<b>95</b>	414	<b>60</b>	600	<b>87</b>	400	<b>58</b>
<b>990K</b>	45/65R39	★, ★★	572	<b>83</b>	352	<b>51</b>	621	<b>90</b>	414	<b>60</b>				
<b>992K</b>	45/65R45	★, ★★	621	<b>90</b>	414	<b>60</b>								
<b>993K</b>	50/65R51	★, ★★	586	<b>85</b>	490	<b>71</b>	655	<b>95</b>	621	<b>90</b>				



*Optimal pressures may vary depending on specific applications and working conditions. Always consult your local tire supplier for operating pressures.*

**WHEEL LOADERS — Radial Ply**

Model	Tire Size	Star Rating	Inflation Pressure												
			Titan				Yokohama				Triangle				
			Front		Rear		Front		Rear		Front		Rear		
			kPa	psi	kPa	psi	kPa	psi	kPa	psi	kPa	psi	kPa	psi	
950GC	23.5R25	★, ★★													
950H	23.5R25	★, ★★													
950K	23.5R25	★, ★★													
950M	23.5R25	★, ★★	483	70	379	55	400	58	365	53					
	750/65R25	★, ★★													
962H	23.5R25	★, ★★													
962K	23.5R25	★, ★★													
962M	23.5R25	★, ★★	552	80	379	55	407	59	372	54					
	750/65R25	★, ★★													
966H	26.5R25	★, ★★	517	75	414	60					503	73	400	58	
966K	26.5R25	★, ★★					448	65	345	50					
966M	26.5R25	★, ★★	503	73	503	73	503	73	276	40	503	73	400	58	
	775/65R29	★, ★★													
972H	26.5R25	★, ★★	517	75	414	60					503	73	400	58	
972K	26.5R25	★, ★★					483	70	345	50					
972M	26.5R25	★, ★★	503	73	503	73	503	73	276	40	503	73	400	58	
	775/65R29	★, ★★													
980H	29.5R25	★, ★★									503	73	400	58	
980K	29.5R25	★, ★★					503	73	303	44					
	875/65R29	★, ★★													
980M	29.5R25	★, ★★	503	73	503	73	503	73	303	44	503	73	400	58	
	875/65R29	★, ★★													
982M	29.5R29	★, ★★													
	875/65R29	★, ★★													
986H	35/65R33	★★, ★★★													
988K	35/65R33	★★, ★★★	648	94	648	94									
990K	45/65R39	★, ★★													
992K	45/65R45	★, ★★	648	94	648	94									
993K	50/65R51	★, ★★													

- Standard Cold Inflation Pressures
- Log Loaders — Bias and Bias Belted
- Log Loaders — Radial Ply

*Optimal pressures may vary depending on specific applications and working conditions. Always consult your local tire supplier for operating pressures.*

**LOG LOADERS — Bias and Bias Belted**

Model	Tire Size	Strength Index	Inflation Pressure							
			Goodyear				Bridgestone/Firestone			
			Front		Rear		Front		Rear	
		kPa	psi	kPa	psi	kPa	psi	kPa	psi	
950H	23.5-25	20	372	54	276	40	345	50	207	30
966H	26.5-25	20, 26	448	65	276	40	414	60	276	40
980H	29.5-25	28	427	62	276	40	586	85	379	55
988K	35/65-33	42	<i>Consult Goodyear</i>				655	95	414	60
990K	41.25/70-39	42					<i>Consult Bridgestone/Firestone</i>			

NOTE: Contact your tire supplier to obtain or confirm proper Log Loader pressures.

NOTE: Pressures for “Log Loaders” are not approved because general application of machine exceeds tire load limit.

**LOG LOADERS — Radial Ply**

Model	Tire Size	Strength Index	Inflation Pressure															
			Michelin				Goodyear				Bridgestone				Eurotire			
			Front		Rear		Front		Rear		Front		Rear		Front		Rear	
		kPa	psi	kPa	psi	kPa	psi	kPa	psi	kPa	psi	kPa	psi	kPa	psi	kPa	psi	
950H	23.5R25	★, ★★	450	65	276	40	476	69	303	44	345	50	207	30				
	650/65R25	★	345	50	241	35												
	750/65R25	★	276	40	207	30												
966H	26.5R25	★, ★★	414	60	276	40	448	65	303	44	414	60	276	40				
	750/65R25	★	414	60	276	40												
980H	29.5R25	★, ★★	517	75	276	40	503	73	303	44	586	85	379	55	585	85	380	55
988K	35/65R33	★★					800	116	600	87	655	95	414	60				
990K	45/65R39	★, ★★	<i>Consult Michelin</i>								<i>Consult Bridgestone</i>							

NOTE: Contact your tire supplier to obtain or confirm proper Log Loader pressures.

NOTE: Pressures for “Log Loaders” are not approved because general application of machine exceeds tire load limit.

## Tires

### Standard Cold Inflation Pressures

- Integrated Toolcarriers — Bias and Bias Belted
- Integrated Toolcarriers — Radial Ply

*Optimal pressures may vary depending on specific applications and working conditions. Always consult your local tire supplier for operating pressures.*

### INTEGRATED TOOLCARRIERS — Bias and Bias Belted

Model	Tire Size	Ply Rating	Inflation Pressure							
			Goodyear				Bridgestone/Firestone			
			Front		Rear		Front		Rear	
		kPa	psi	kPa	psi	kPa	psi	kPa	psi	
IT62H	23.5-25	16	372	54	248	36	345	50	207	30

NOTE: Contact your tire supplier to obtain or confirm proper Integrated Toolcarrier pressures.

### INTEGRATED TOOLCARRIERS — Radial Ply

Model	Tire Size	Star Rating	Inflation Pressure											
			Michelin				Goodyear				Bridgestone			
			Front		Rear		Front		Rear		Front	Rear		
		kPa	psi	kPa	psi	kPa	psi	kPa	psi	kPa	psi	kPa	psi	
IT62H	23.5R25	★	345	50	241	35	427	62	276	40	345	50	207	30

NOTE: Contact your tire supplier to obtain or confirm proper Integrated Toolcarrier pressures.

*Optimal pressures may vary depending on specific applications and working conditions. Always consult your local tire supplier for operating pressures.*

**WHEEL DOZERS — Bias Ply**

Model	Tire Size	Ply Rating	Inflation Pressure										
			Bridgestone/Firestone				Titan						
			Front		Rear		Front		Rear				
kPa	psi	kPa	psi	kPa	psi	kPa	psi	kPa	psi				
834K	35/65-33	42	345	50	379	55							
844K	41.25/70-39	42	483	70	414	60	476	69	476	69			
854K	45/65-45	58	655	95	414	60	676	98	676	98			

**WHEEL DOZERS — Radial Ply**

Model	Tire Size	Star Rating	Inflation Pressure											
			Michelin				Bridgestone/Firestone				Titan			
			Front		Rear		Front		Rear		Front		Rear	
kPa	psi	kPa	psi	kPa	psi	kPa	psi	kPa	psi	kPa	psi	kPa	psi	
814F2	23.5R25	★	352	51	324	47								
824K	875/65R29	★	352	51	352	51	496	72	421	61				
824HQ	29.5R25	★★	352	51	352	51								
834K	35/65R33	★★, ★★★	400	58	400	58	345	50	414	60	648	94	648	94
844K	45/65R39	★	303	44	303	44	379	55	379	55				
854K	45/65R45	★★	379	55	310	45					648	94	648	94

*Optimal pressures may vary depending on specific applications and working conditions. Always consult your local tire supplier for operating pressures.*

**HARD ROCK UNDERGROUND MINING — Bias and Radial Ply**

Model	Tire Size	Ply Rating/ Star Rating	Inflation Pressure											
			Michelin		Goodyear		Bridgestone							
			Front	Rear	Front	Rear	Front	Rear						
			kPa	psi	kPa	psi	kPa	psi	kPa	psi	kPa	psi		
<b>LOAD-HAUL-DUMP LOADERS</b>														
<b>R1300G</b>	17.5R25	★★, ★★★	690	100	622	90	750	109	550	80	650	94	480	70
	17.5-25	20	N/A		N/A		725	105	525	76	650	94	480	70
<b>R1600G</b>	18.0R25	★★	690	100	518	75	N/A		N/A		690	100	450	65
	18.0-25	28	N/A		N/A		700	102	500	73	690	100	450	65
<b>R1600H</b>	18.0R25	★★	724	105	500	73	700	102	551	80	724	105	525	76
	18.0-25	28	N/A		N/A		700	102	480	70	750	109	372	54
<b>R1700G</b>	26.5R25	★★	690	100	448	65	700	102	500	73	650	94	450	65
	26.5-25	32, 36	N/A		N/A		700	102	500	73	650	94	450	65
<b>R2900G</b>	29.5R29	★★	622	90	415	60	N/A		N/A		650	94	450	65
	29.5-29	34, 40	N/A		N/A		725	105	525	76	650	94	450	65
<b>R3000H</b>	35/65R33	★★	N/A		N/A		650	94	450	65	650	94	450	65
<b>ARTICULATED TRUCKS</b>														
<b>AD30</b>	26.5R25	★, ★★	517	75	655	95	450	65	600	87	650	94	650	94
<b>AD45B</b>	29.5R29	★★	620	90	655	95	500	73	630	91	650	94	650	94
<b>AD55B</b>	35/65R33	★, ★★	758	110	758	110	550	80	630	91	650	94	650	94
<b>AD60</b>	35/65R33	★★★★	724	105	724	105	<i>No data available</i>				705	102	705	102

**BIAS PLY TIRES**

**RADIAL PLY TIRES**

Tire Size	Weight Increase Per Tire		Mixing Proportions				Weight Increase Per Tire		Mixing Proportions			
			CaCl		Water				CaCl		Water	
	kg	lb	kg	lb	L	gal	kg	lb	kg	lb	L	gal
13.00 × 24TG	188	<b>414</b>	55	<b>122</b>	132	<b>35</b>	185	<b>407</b>	57	<b>125</b>	128	<b>34</b>
14.00 × 24TG	215	<b>475</b>	63	<b>140</b>	151	<b>40</b>	256	<b>565</b>	79	<b>173</b>	179	<b>47</b>
15.5 × 25	192	<b>423</b>	56	<b>125</b>	136	<b>36</b>	224	<b>493</b>	69	<b>151</b>	155	<b>41</b>
16.00 × 24TG	333	<b>735</b>	98	<b>217</b>	234	<b>62</b>	355	<b>783</b>	109	<b>240</b>	246	<b>65</b>
17.5 × 25	262	<b>577</b>	77	<b>170</b>	185	<b>49</b>	311	<b>686</b>	95	<b>210</b>	216	<b>57</b>
18.00 × 25	454	<b>1002</b>	134	<b>296</b>	322	<b>85</b>	502	<b>1107</b>	154	<b>340</b>	348	<b>92</b>
18.4 × 34	417	<b>919</b>	123	<b>272</b>	295	<b>78</b>	—	—	—	—	—	—
20.5 × 25	405	<b>892</b>	119	<b>263</b>	284	<b>75</b>	448	<b>987</b>	137	<b>303</b>	310	<b>82</b>
23.1 × 26	522	<b>1151</b>	154	<b>340</b>	367	<b>97</b>	—	—	—	—	—	—
23.5 × 25	585	<b>1291</b>	173	<b>382</b>	412	<b>109</b>	633	<b>1396</b>	194	<b>428</b>	439	<b>116</b>
24.5 × 32	703	<b>1549</b>	207	<b>458</b>	496	<b>131</b>	—	—	—	—	—	—
26.5 × 25	758	<b>1671</b>	224	<b>494</b>	533	<b>141</b>	841	<b>1853</b>	258	<b>568</b>	583	<b>154</b>
26.5 × 29	752	<b>1658</b>	222	<b>490</b>	530	<b>140</b>	928	<b>2045</b>	284	<b>627</b>	644	<b>170</b>
28L × 26	709	<b>1563</b>	209	<b>462</b>	500	<b>132</b>	—	—	—	—	—	—
29.5 × 25	970	<b>2139</b>	286	<b>632</b>	685	<b>181</b>	1073	<b>2368</b>	328	<b>723</b>	745	<b>197</b>
29.5 × 29	1050	<b>2315</b>	310	<b>684</b>	738	<b>195</b>	1190	<b>2623</b>	365	<b>804</b>	825	<b>218</b>
875/65 × 29	—	—	—	—	—	—	1445	<b>3186</b>	429	<b>946</b>	1016	<b>268</b>
29.5 × 35	1159	<b>2556</b>	344	<b>758</b>	821	<b>217</b>	1286	<b>2835</b>	394	<b>869</b>	892	<b>236</b>
30.5L × 32	874	<b>1928</b>	258	<b>570</b>	617	<b>163</b>	—	—	—	—	—	—
33.25 × 35	1485	<b>3275</b>	439	<b>968</b>	1048	<b>277</b>	1592	<b>3508</b>	487	<b>1074</b>	1105	<b>292</b>
37.25 × 35	1712	<b>3775</b>	505	<b>1115</b>	1211	<b>320</b>	2128	<b>4692</b>	653	<b>1439</b>	1476	<b>390</b>
38 × 39	1870	<b>4123</b>	552	<b>1218</b>	1317	<b>348</b>	—	—	—	—	—	—
35/65 × 33	1339	<b>2953</b>	396	<b>873</b>	942	<b>249</b>	1430	<b>3152</b>	438	<b>967</b>	992	<b>262</b>
40/65 × 39	2077	<b>4580</b>	614	<b>1353</b>	1465	<b>387</b>	2194	<b>4836</b>	673	<b>1483</b>	1522	<b>402</b>
41.25/70 × 39	1897	<b>4183</b>	561	<b>1236</b>	1336	<b>353</b>	—	—	—	—	—	—
45/65 × 45	2548	<b>5617</b>	753	<b>1659</b>	1794	<b>474</b>	—	—	—	—	—	—

**NOTE:** Ballast weight for bias ply tires from Goodyear data, radial ply weights from Michelin data. Contact your tire supplier for additional information. Under abnormal tire wear conditions, ballasting of rear tires may be desirable. Ballasting of front tires also should only be done where extremely rapid tire wear rates are encountered. Excessive weight will reduce machine performance.

**NOTE:** Fillage beyond 75% of tire enclosed volume is not recommended. With liquid ballasting, inflation pressure must be checked at least once per day.

**NOTE:** 1.6 kg (3½ lb) Calcium Chloride per gallon water. Solution weighs 4.6 kg (10.15 lb) per gallon.

**NOTE:** Total machine mass including all attachments in operating condition, all reservoirs at full capacity and ballasted tires must not exceed certification mass listed on the ROPS certification label.

**NOTE:** Special air to water valves are required for liquid filled tires.



SEBD0351-47

© 2017 Caterpillar • All Rights Reserved  
CAT, CATERPILLAR, SAFETY.CAT.COM, their respective logos, "Caterpillar Yellow"  
and the "Power Edge" trade dress, as well as corporate and product identity used  
herein, are trademarks of Caterpillar and may not be used without permission.

